

## INTERCONNECTION AGREEMENT

This interconnection agreement ("Agreement") is made and entered into this 25th day of February, 2020, by and between Kentucky Power Company ("Company"), and Inez Power, LLC ("Customer"). Company and Customer are hereinafter sometimes referred to individually as "Party" or collectively as "Parties".

### WITNESSETH:

WHEREAS, Customer is installing, or has installed, generation equipment, controls, and protective relays and equipment ("Generation Facilities") used to interconnect and operate in parallel with Company's electric system, which Generation Facilities are more fully described in Exhibit A, attached hereto and incorporated herein by this Agreement, and as follows:

Location: 900 Middle Fork, Wolf Creek Road, Debord, KY 41224

Generator Size and Type: 6800KW BE1 - 11g Generator

NOW, THEREFORE, in consideration thereof, Customer and Company agree as follows:

**1. Interconnection Application.** It is understood and agreed that this Agreement applies only to the operation of the Generation Facilities described above and on Exhibit A.

**2. Interconnection.** Company agrees to allow Customer to interconnect and operate the Generation Facilities in parallel with Company's electric system in accordance with any operating procedures or other conditions specified in Exhibit B. The Company does not give any warranty, express or implied, by this Agreement, or by inspection, if any, or by non-rejection, or by approval, or in any other way, as to the adequacy, safety, compliance with applicable codes or requirements, or as to any other characteristics, of the Generation Facilities. The Generation Facilities installed and operated by or for Customer shall comply with, and Customer represents and warrants their compliance with: (a) the National Electrical Code and the National Electrical Safety Code, as each may be revised from time to time; (b) Company's rules and regulations, including Company's COGEN/SPP II (Cogeneration and/or Small Power Production – Over 100 KW) Tariff and Company's Teams and Conditions of Service, each as contained in Company's Retail Electric Tariff, as each may be revised from time to time with the approval of the Public Service Commission of Kentucky ("Commission"); (c) the rules and regulations of the Commission, including the provisions of 807 KAR 5:054, as such rules and regulations may be revised from time to time by the Commission; and (d) all other applicable local, state, and federal codes and laws, as the same may be in effect from time to time.

Customer shall install, operate, maintain, and test and inspect at Customer's sole cost and expense, the Generation Facilities in accordance with *IEEE 1547 "IEEE Standard for Interconnecting Distributed Resources with Electric Power Systems."* (IEEE 1547) and the manufacturer's suggested practices for safe, efficient and reliable operation of the Generation Facilities in parallel with Company's electric system. Customer shall bear sole responsibility

for the installation, maintenance, and safe operation of the Generation Facilities. Upon request from the Company, Customer shall supply copies of periodic test reports or inspection logs.

Customer shall be responsible for protecting, at Customer's sole cost and expense, the Generation Facilities from any condition or disturbance on Company's electric system, including, but not limited to, voltage sags or swells, system faults, outages, loss of a single phase of supply, equipment failures, and lightning or switching surges.

Customer agrees that, without the prior written permission from Company, no changes shall be made to the configuration of the Generation Facilities, as that configuration is described in Exhibit A, and no relay or other control or protection settings specified in Exhibit A shall be set, reset, adjusted or tampered with, except to the extent necessary to verify that the Generation Facilities comply with Company approved settings.

**3. Operation by Customer.** Customer shall operate the Generation Facilities in such a manner as not to cause undue fluctuations in voltage, intermittent load characteristics or otherwise interfere with the operation of Company's electric system. At all times when the Generation Facilities are being operated in parallel with Company's electric system, Customer shall so operate the Generation Facilities in such a manner that no disturbance will be produced thereby to the service rendered by Company to any of its other customers or to any electric system interconnected with Company's electric system. Customer understands and agrees that the interconnection and operation of the Generation Facilities pursuant to this Agreement is secondary to, and shall not interfere with, Company's ability to meet its primary responsibility of furnishing reasonably adequate service to its customers.

Customer's control equipment for the Generation Facilities shall immediately, completely, and automatically disconnect and isolate the Generation Facilities from Company's electric system in the event of a fault on Company's electric system, a fault on Customer's electric system, or loss of a source or sources on Company's electric system. The automatic disconnecting device included in such control equipment shall not be capable of reclosing until after service is restored on Company's electric system. Additionally, if the fault is on Customer's electric system, such automatic disconnecting device shall not be reclosed until after the fault is isolated from Customer's electric system. Customer shall promptly notify Company whenever such automatic disconnecting devices operate.

**4. Access and Inspection by Company.** Customer shall provide the Company reasonable opportunity to inspect the Generation Facilities prior to operation, and shall furnish the Company the opportunity to witness the initial testing and commissioning of the Generation Facilities. Company may witness any commissioning tests required by IEEE 1547. Following the initial testing and inspection of the Generation Facilities and upon reasonable advance notice to Customer, Company shall have access at reasonable times to the Generation Facilities to perform reasonable on-site inspections to verify that the installation, maintenance and operation of the Generation Facilities comply with the requirements of this Agreement. The Company's cost of such inspection(s) shall be at Company's expense; however, Company shall not be responsible for any other cost Customer may incur as a result of such inspection(s). Customer shall inform Company of the

next scheduled maintenance and allow Company to witness the maintenance program and any associated testing. Company at all times shall have immediate access to Customer's breakers or any other equipment that will isolate the Generation Facilities from Company's electric system.

**5. Disconnection of Generation Facilities.** Company shall have the right and authority to isolate the Generation Facilities at Company's sole discretion if Company believes that: (a) continued interconnection and parallel operation of the Generation Facilities with Company's electric system creates or contributes (or will create or contribute) to a system emergency on either Company's or Customer's electric system; (b) the Generation Facilities are not in compliance with the requirements of this Agreement, and the non-compliance adversely affects the safety, reliability or power quality of Company's electric system; or (c) the Generation Facilities interfere with the operation of Company's electric system. Except in emergency situations, Company shall give Customer reasonable notice of noncompliance including a description of the specific noncompliance condition; Company shall allow Customer a reasonable time to cure the noncompliance prior to isolating the Generating Facilities.

The Customer retains the option to temporarily disconnect from the Company's system at any time. Such temporary disconnection shall not be a termination of this Agreement unless the Customer exercises its termination rights under Section 9.

Company shall provide Customer with seven business days' notice of service interruptions for routine maintenance and repairs on Company's utility system.

**6. Rates and Other Charges.** (a) Customer shall take electric service from Company at the rates set forth in and pursuant to the terms and conditions of Company's Tariff COGEN/SPP II (Cogeneration and/or Small Power Production – Over 100 KW) and Exhibit C as they may be amended from time to time. This Agreement does not constitute an agreement by Company to wheel power produced by the Generation Facilities, or to furnish any backup, supplemental or other power or services associated with the Generation Facilities, and this Agreement does not address any charges for facilities that may be installed by Company in connection with interconnection of the Generation Facilities.

(b) It is understood that if Customer desires for the Company to wheel power produced by the Generation Facilities, or to furnish any backup, supplemental or other power or services associated with the Generation Facilities, then Company and Customer may enter into a separate mutually acceptable agreement detailing the charges, terms and conditions of such wheeling, or such backup, supplemental or other power or services. It is also understood that if any facilities are required, including any additional metering equipment, as determined by Company, in order for the Generation Facilities to interconnect with and operate in parallel with Company's electric system, then a separate agreement shall be executed by Company and Customer detailing the charges and terms and conditions of payment.

**7. Insurance.** Customer shall maintain at its sole cost reasonable amounts of insurance coverage against risks related to the Generation Facilities for which there is a reasonable

likelihood of occurrence as agreed by Customer and Company acting in good faith. Customer shall provide Company from time to time with proof of such insurance upon Company's request.

**8. Indemnification.** Each Party (the "Indemnifying Party") to the extent permitted by law shall indemnify and hold harmless the other Party from and against all claims, liability, damages and expenses, including attorney's fees, based on any injury to any person, including the loss of life, or damage to any property, including the loss of use thereof, arising out of, resulting from, or connected with, or that may be alleged to have arisen out of, resulted from, or connected with, an act or omission by the Indemnifying Party, its employees, agents, representatives, successors or assigns in the construction, ownership, operation or maintenance of the Indemnifying Party's facilities used in connection with this Agreement. Upon written request of the Party seeking relief under this Section 8, the Indemnifying Party shall defend at its expense any suit asserting a claim covered by this Section 8. If a Party is required to bring an action to enforce its rights under this Section 8, either as a separate action or in connection with another action, and the Indemnifying Party is determined by a final and non-appealable judgment to have breached its obligations under this Section 8, the Indemnifying Party shall reimburse such Party for all expenses, including attorney's fees, incurred in connection with establishing such breach.

**9. Effective Term and Termination Rights.** This Agreement shall become effective when executed by both Parties and shall continue in effect for at least one year and, thereafter, until terminated in accordance with the provisions of this Agreement. This Agreement may be terminated for the following reasons: (a) Customer may terminate this Agreement by giving Company at least sixty (60) days' prior written notice stating Customer's intent to terminate this Agreement at the expiration of such notice period; (b) Company may terminate this Agreement following Customer's failure to generate energy from the Generation Facilities in parallel with Company's electric system by the later of two years from the date of execution of this Agreement or twelve (12) months after completion of the interconnection provided for by this Agreement; (c) either Party may terminate this Agreement by giving the other Party at least sixty (60) days' prior written notice that the other Party is in default of any of the material terms and conditions of this Agreement, so long as the notice specifies the basis for termination and there is reasonable opportunity for the Party in default to cure the default; or (d) Company may terminate this Agreement by giving Customer at least sixty (60) days' prior written notice in the event that there is a change in an applicable rule or statute affecting this Agreement.

Upon termination of this Agreement, Customer's Generation Facilities shall be disconnected at Customer's sole expense from the Company's system.

Termination of this Agreement shall not relieve either party of its liabilities and obligations, owed or continuing at the time of the termination.

**10. Termination of Any Applicable Existing Agreement.** From and after the date when service commences under this Agreement, this Agreement shall supersede any oral and/or written agreement or understanding between Company and Customer concerning the

service covered by this Agreement and any such agreement or understanding shall be deemed to be terminated as of the date service commences under this Agreement.

**11. Force Majeure.** For purposes of this Agreement, the term “Force Majeure” means any cause or event not reasonably within the control of the Party claiming Force Majeure, including, but not limited to, the following: acts of God, strikes, lockouts, or other industrial disturbances; acts of public enemies; orders or permits or the absence of the necessary orders or permits of any kind which have been properly applied for from the government of the United States, the Commonwealth of Kentucky, any political subdivision or municipal subdivision or any of their departments, agencies or officials, or any civil or military authority; unavailability of a fuel or resource used in connection with the generation of electricity; extraordinary delay in transportation; unforeseen soil conditions; equipment, material, supplies, labor or machinery shortages; epidemics; landslides; lightning; earthquakes; fires; hurricanes; tornadoes; storms; floods; washouts; drought; arrest; war; civil disturbances; explosions; breakage or accident to machinery, transmission lines, pipes or canals; partial or entire failure of utilities; sabotage; injunction; blight; famine; blockade; or quarantine.

If either Party is rendered wholly or partly unable to perform its obligations under this Agreement because of Force Majeure, both Parties shall be excused from whatever obligations under this Agreement are affected by the Force Majeure (other than the obligation to pay money) and shall not be liable or responsible for any delay in the performance of, or the inability to perform, any such obligations for so long as the Force Majeure continues. The Party suffering an occurrence of Force Majeure shall, as soon as is reasonably possible after such occurrence, give the other Party written notice describing the particulars of the occurrence and shall use commercially reasonable efforts to remedy its inability to perform; provided, however, that the settlement of any strike, walkout, lockout or other labor dispute shall be entirely within the discretion of the Party involved in such labor dispute.

**12. Dispute Resolution.** In the event that Customer and Company are unable to agree on matters relating to this Agreement, either Customer or Company may submit a complaint to the Commission or to a court of competent jurisdiction, as appropriate under the circumstances of the dispute.

**13. Commission Jurisdiction.** Both Company and this Agreement are subject to the jurisdiction of the Commission. To the extent that Commission approval of this Agreement may be required now or in the future, this Agreement and Company’s commitments hereunder are subject to such approval.

IN WITNESS WHEREOF, the Parties have executed this Agreement, effective as of the date first above written.

**Kentucky Power Company**

By: Ken Borders

Printed Name: Ken Borders

Title: Mgr. Cust and Dist Svces

**Inez Power, LLC**

By: DB Kaze

Printed Name: DB KAZEE

Title: GC / Member

**Exhibit A – Generation Facilities**

**Exhibit B – Facilities Required for Interconnection**

**Exhibit C – Cogeneration and/or Small Power Production Application**

EXHIBIT A

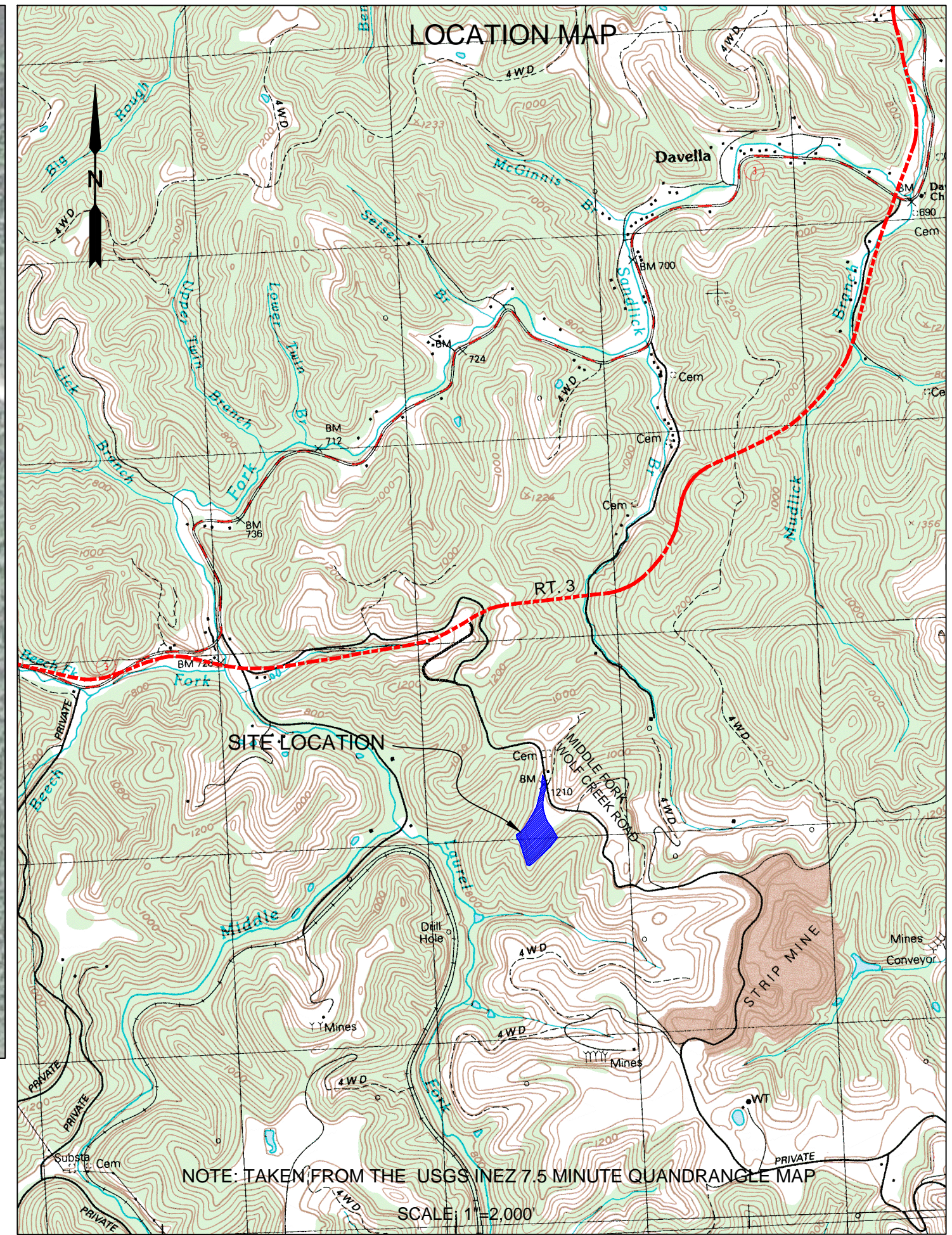
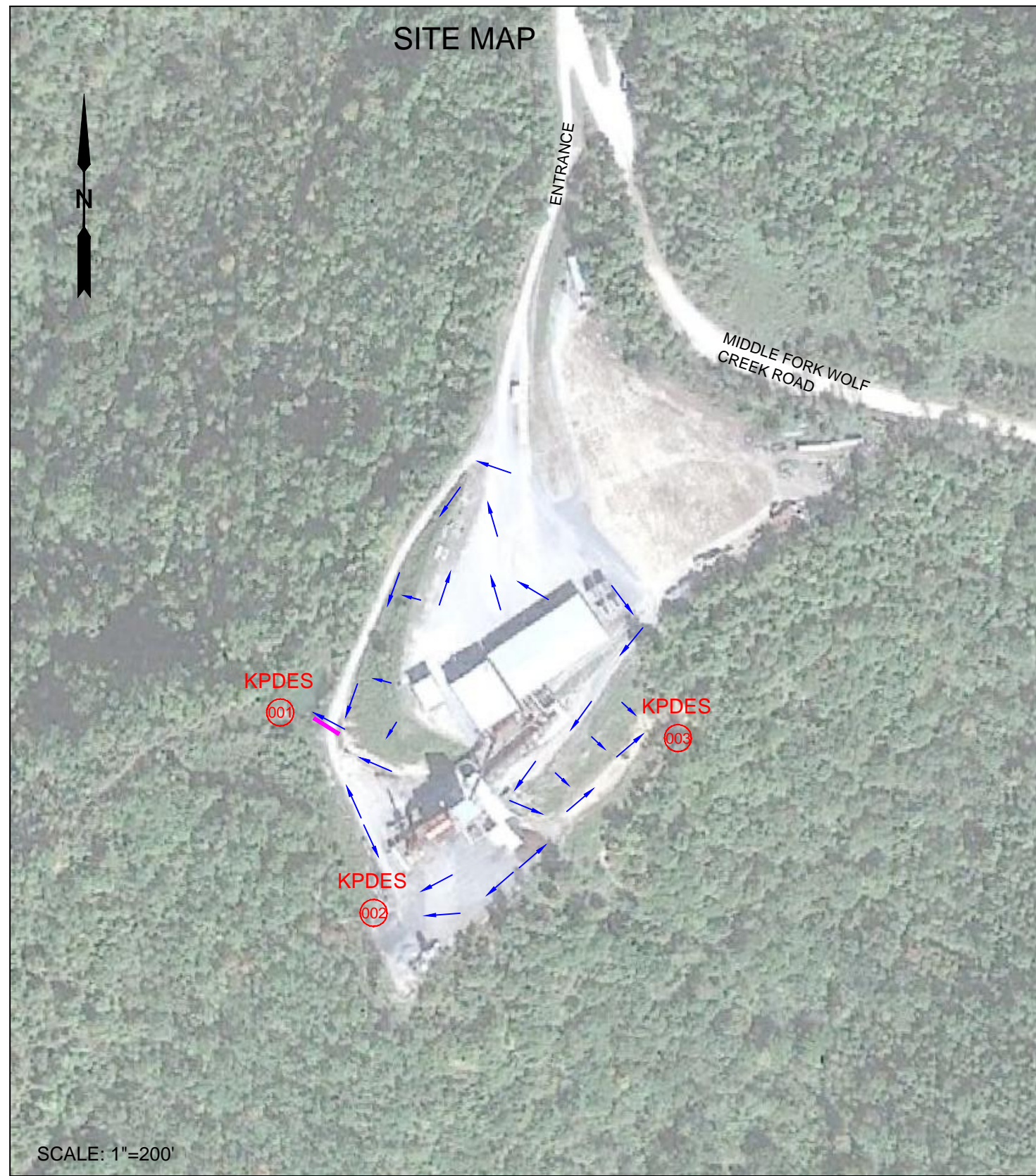

**RECYCLING SOLUTIONS  
TECHNOLOGY, LLC.**  
 SITE DRAINAGE MAP/LOCATION MAP  
 MIDDLE FORK WOLF CREEK ROAD  
 MARTIN COUNTY, KY  
 2-20-2012

- LEGEND**
- KPDES 001 Proposed KPDES Monitoring Point
  - Surface Runoff Drainage Direction
  - Existing Culvert

KPDES PNT.	LAT.	LON.
001	37°46'03"	82°35'44"
002	37°46'00"	82°35'42"
003	37°46'03"	82°35'37"



APPLICATION FOR INTERCONNECTION WITH THE AMERICAN ELECTRIC POWER DISTRIBUTION SYSTEM

Instructions

Interconnection Customer declares its intention to interconnect with the AEP Distribution System.

In order for the Distributed Resource to be considered for interconnection to AEP's Distribution System, Interconnection Customer must submit (1) a completed Interconnection Request (The Interconnection Request shall be deemed complete when the required information has been provided by Interconnection Customer), and (2) the appropriate non-refundable application fee.

If requested information is not applicable, indicate by using "N/A".

Additional information to evaluate an Interconnection Request may be required by AEP as the application process proceeds.

Return Completed Application to: American Electric Power, Distributed Generation Coordinator, 1 Riverside Plaza, Columbus, Ohio 43215

Application Fee

Indicate the amount of fee enclosed: \$ 100.00

Section 1 Interconnection Customer Information

Indicate Distributed Resource size: [ ] Up to 30 kW, [ ] 30 - 149 kW, [ ] 150 - 749 kW, [ ] 750 - 1,999 kW, [X] 2,000 kW and greater

Application is for: [X] New Distributed Resource Facility, [ ] Capacity addition to Existing Distributed Resource Facility

If capacity addition to existing facility, please describe:

Three horizontal lines for describing capacity addition to existing facility.

**Legal Name of Interconnection Customer** (or, if an Individual, Individual's Name)

Name: Inez Power LLC.

Mailing Address: P.O. Box 367

City: Allen State: KY Zip: 41601

Generating Facility Location (if different from above):  
900 Middle Fork Wolfe Creek Rd

Debord KY 41214

Requested Point of Interconnection:  
\_\_\_\_\_  
\_\_\_\_\_

If the requested point of interconnection is the same as an existing electric service, provide the electric service account number.

[REDACTED]

Proposed In-Service Date: 6/1/2018

Telephone: Daytime: 606-298-3080 Evening: 606-471-0051

E-Mail Address: recyclingsolutionstechnology@gmail.com Fax: \_\_\_\_\_

**Alternative Contact Information** (If different from Interconnection Customer information above)

Contact Name: Lee Bazzle

Title: Project Manager

Mailing Address:  
450 Sedgewich Rd

City: Summerville State: SC Zip: 29483

Telephone: Daytime: 843-817-8383 Evening: 843-817-8383

E-Mail Address: leebazzle@gmail.com Fax: \_\_\_\_\_

Contact Name: Paul Aiken

Title: Project Leader

Mailing Address:  
421 Sycamore Hollow

City: Prestonsburg State: KY Zip: 41653

Telephone: Daytime: \_\_\_\_\_ Evening: \_\_\_\_\_

E-Mail Address: \_\_\_\_\_ Fax: \_\_\_\_\_

**Section 2 Generator Qualifications**

Energy Source:  Diesel  Hydro [*Specify Type (e.g., Run-of-River)*] \_\_\_\_\_  
 Fuel Oil  Natural Gas  Solar  Wind  
 Other (*Specify*) Steam, alternative fuel

Type of Generator:  
 Synchronous  Induction  DC Generator with Inverter/Converter

Generator Nameplate Rating: 7245 kW (*Typical*)

Generator Nameplate KVA: 9056

Interconnection Customer or Customer-Site Load:

2400 kW (*if none, so state*) (*Typical*)

1800 kVAR (*Reactive Load, if known*)

Maximum physical export capability requested: 6800 kW

**List components of the Generating Facility that are Pre-certified**

<u>Equipment Type</u>	<u>Pre-certifying Entity</u>
Basler BE1-11i Intertie Protection Relay	UL
Basler BE1-11g Generator Protection Relay	UL
5kV Circuit Breaker	Manufactured to ANSI Standards
Surge arrestors	Manufactured to ANSI Standards
Generator	Manufactured to ANSI Standards

**Section 3 Generator Technical Information**

*A completed load flow data sheet must be supplied with the Interconnection Request.*

Distributed Resource manufacturer, model name, number, and version:

Electric Machinery TEWAC size 4G5250, 9056 kVA 0.8 pf

Serial number 184348211

Nameplate output power rating in kW: (Summer) 7245 (Winter) 7245

Nameplate output power rating in KVA: (Summer) 9056 (Winter) 9056

Individual generator power factor: Rated power factor leading: 0.8

Rated power factor lagging: 0.8

**Wind Generators**

Number of generators to be interconnected pursuant to this Interconnection Request: \_\_\_\_

Elevation: \_\_\_\_\_ Single Phase \_\_\_\_\_ Three Phase

Inverter manufacturer, model name, number, and version:

---

---

List of adjustable set points for the protective equipment or software:

---

---

**Distributed Resource Facility Characteristic Data** *(for rotating machines)*

**Synchronous and Induction Generators:**

Direct Axis Transient Reactance,  $X'_d$ : 0.17 P.U.

Direct Axis Unsaturated Transient Reactance,  $X'_{di}$ : 0.18 P.U.

Direct Axis Subtransient Reactance,  $X''_d$ : 0.10 P.U.

Generator Saturation Constant (1.0): 1.07

Generation Saturation Constant (1.2): 1.18

Negative Sequence Reactance: 0.20 P.U.

Zero Sequence Reactance: 0.07 P.U.

KVA Base: 9056

RPM Frequency: 1800

Induction Generators:

- (\*) Field Volts: \_\_\_\_\_
- (\*) Field Amperes: \_\_\_\_\_
- (\*) Motoring Power (kW): \_\_\_\_\_
- (\*) Neutral Grounding Resistor (If Applicable): \_\_\_\_\_
- (\*)  $I_2^2t$  or K (Heating Time Constant): \_\_\_\_\_
- (\*) Rotor Resistance: \_\_\_\_\_
- (\*) Stator Resistance: \_\_\_\_\_
- (\*) Stator Reactance: \_\_\_\_\_
- (\*) Rotor Reactance: \_\_\_\_\_
- (\*) Magnetizing Reactance: \_\_\_\_\_
- (\*) Short Circuit Reactance: \_\_\_\_\_
- (\*) Exciting Current: \_\_\_\_\_
- (\*) Temperature Rise: \_\_\_\_\_
- (\*) Frame Size: \_\_\_\_\_
- (\*) Design Letter: \_\_\_\_\_
- (\*) Reactive Power Required In Vars (No Load): \_\_\_\_\_
- (\*) Reactive Power Required In Vars (Full Load): \_\_\_\_\_
- (\*) Total Rotating Inertia, H: \_\_\_\_\_ Per Unit on KVA Base

*Note: Please consult AEP prior to submitting the Interconnection Request to determine if the information designated by (\*) is required.*

**Excitation and Governor System Data** *(for Synchronous Generators only)*

If determined to be required, provide appropriate IEEE model block diagram of excitation system, governor system, and power system stabilizer (PSS) in accordance with the regional reliability council criteria. A PSS may be determined to be required by applicable studies. A copy of the manufacturer's block diagram may not be substituted.

Note: System stability study is not required per customer guide for interconnection, Appendix 1.

**Section 4. Interconnecting Equipment Technical Data Information**

Will a transformer be used between the Distributed Resource and the Point of Interconnection?  Yes  No

Transformer is assumed to be provided by AEP at this point in time, based on preliminary discussions.

**Transformer Data for Interconnection Customer-Owned Transformer** *(if applicable)*

*Load loss watts values will be estimated at 5-10% of nameplate impedance if load loss watts values are not specified.*

The transformer is:  single phase  three phase Size:  KVA

Transformer impedance:  % on  KVA Base

If Three Phase:

Transformer Primary:  Volts  Delta  Wye  Wye Grounded

Transformer Secondary:  Volts  Delta  Wye  Wye Grounded

**Transformer Fuse Data for Interconnection Customer-owned Fuse** *(if applicable)*

---

*Note: Please attach a copy of fuse manufacturer's minimum melt and total clearing time- current curves*

Fuse Manufacturer:

Type:  Size:  Speed:

**Interconnecting Circuit Breaker (if applicable)**

Manufacturer: T.B.D. (To be determined)

Type: T.B.D. Load Rating (Amps): 2000 Interrupting Rating (Amps): 29 kA

Trip Speed (Cycles): 5

**Interconnection Protective Relays (if applicable)**

*Note: Please attach a copy of any proposed time-overcurrent coordination curves*

Manufacturer: Basler

Type: BE 1-11i Style/Catalog No.: T.B.D. Proposed Setting: T.B.D.

Manufacturer: \_\_\_\_\_

Type: \_\_\_\_\_ Style/Catalog No.: \_\_\_\_\_ Proposed Setting: \_\_\_\_\_

Manufacturer: \_\_\_\_\_

Type: \_\_\_\_\_ Style/Catalog No.: \_\_\_\_\_ Proposed Setting: \_\_\_\_\_

Manufacturer: \_\_\_\_\_

Type: \_\_\_\_\_ Style/Catalog No.: \_\_\_\_\_ Proposed Setting: \_\_\_\_\_

Manufacturer: \_\_\_\_\_

Type: \_\_\_\_\_ Style/Catalog No.: \_\_\_\_\_ Proposed Setting: \_\_\_\_\_

**Current Transformer Data (if applicable)**

*Note: Please attach a copy of manufacturer's excitation & ratio correction curves*

Manufacturer: T.B.D.

Type: T.B.D. Accuracy Class: C200 Proposed Ratio Connection: 1200/5

Manufacturer: \_\_\_\_\_

Type: \_\_\_\_\_ Accuracy Class: \_\_\_\_\_ Proposed Ratio Connection: /5

**Potential Transformer Data (if applicable)**

Manufacturer: T.B.D.  
Type: T. BD. Accuracy Class: 0.3 Proposed Ratio Connection: 4160/120

Manufacturer: \_\_\_\_\_  
Type: \_\_\_\_\_ Accuracy Class: \_\_\_\_\_ Proposed Ratio Connection: \_\_\_\_/5

**Section 5. General Information**

Attached is a one-line diagram showing the configuration of all generating facility equipment, current and potential circuits, and protection and control schemes.

Note: Detailed design one line diagram is in progress. General one line included.

Attached is site documentation that indicates the precise physical location of the proposed generating facility (e.g., USGS topographic map or other diagram or documentation).

\_\_\_\_ Attached is documentation that describes and details the operation of the protection and control schemes.

Note: Detailed P&C design is in progress.

Proposed location of protective interface equipment on property (Include address if different from Interconnection Customer's address):

\_\_\_\_\_  
\_\_\_\_\_

\_\_\_\_ Attached are copies of schematic drawings for all protection and control circuits, relay current circuits, relay potential circuits, and alarm/monitoring circuits (if applicable).

Note: Detailed P&C design is in progress.

Attached is Site Control documentation.

Does Interconnection Customer currently have control of the site?  Yes \_\_\_\_\_ No

**Section 6. Signature**

I hereby certify that, to the best of my knowledge, all the information provided in this Interconnection Request is true and correct. For Interconnection Customer:

Print Name:  
Lee Bazzle

---

Signature: 

---

Date: 2/7/14

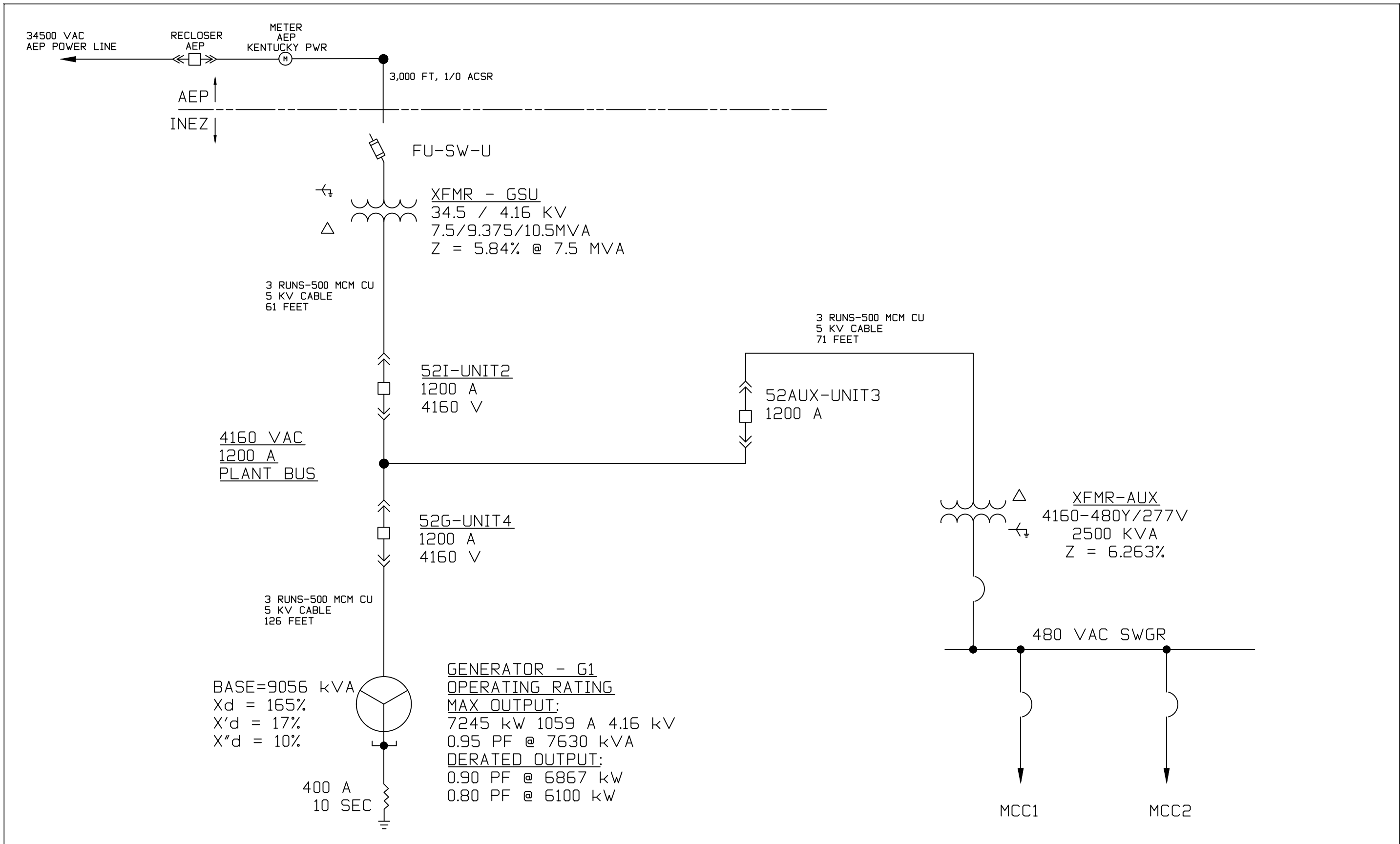

3518504  
07/24/18  
12/21/18

THIS DOCUMENT IS THE PROPERTY OF WUNDERLICH-MALEC ENG INC., AND MAY NOT BE REPRODUCED WITHOUT WRITTEN PERMISSION OR USED FOR OTHER THAN WUNDERLICH-MALEC ENG AUTHORIZED PURPOSES

No.	DATE	DESCRIPTION	BY	CHK	APP
3	10/9/20	ADD RECLOSER, LINE DISTANCE/TYPE, XFMR NAMEPLATE	BRP	MH	EL
2	12/21/18	UPDATED PER EQUIPMENT RATING	MA	MH	EL
1	07/24/18	UPDATED INEZ / AEP DEMARCATION	MH	MH	EL
0	02/01/18	INTERCONNECT APP. FOR REVIEW	AS	MH	EL



**WUNDERLICH-MALEC SYSTEMS, INC.**  
 Phone: (603) 430-0288  
 Fax: (603) 430-5409  
 8 Merrill Industrial Dr., Unit 8  
 Hampton, NH 03842

THIS DRAWING IS INTENDED FOR USE ON THE PROJECT LISTED HEREIN. REPRODUCTION IS AUTHORIZED BY WUNDERLICH-MALEC ENGINEERING INC., FOR USE ON THIS PROJECT ONLY.

DRAWN BY: AS DATE: 01/30/18	REVIEWED BY: MH DATE: 1/31/18	APPROVED BY: EL DATE: 1/31/18
--------------------------------------	--	--

PROJECT No. 3518504      SCALE: NONE

INEZ POWER GENERATION, LLC  
 1620 RICHMOND RD, LEXINGTON, KY  
 INEZ PLANT DESIGN SUPPORT

GENERATOR INTERCONNECT		
SIMPLE ONE LINE		
DRAWING No.	SHEET No.	REVISION
3518504-E-100	10F1	2



EXHIBIT B

**Distribution Impact Study**  
**For Inez Power LLC**  
**Distribution Generation Interconnection Request**  
**For 6,800 KVA of alternative powered generation**  
**900 Middle Fork/Wolfe Creek Road**  
**Debord, KY 41214**  
**Confidential**

B. McMillion

Charleston Distribution System Planning

July 20, 2018

Distribution List:      T. L. Hemsworth  
  
                                 L. M. Freeh  
  
                                 J. M. Neal  
  
                                 G. S. Sumner  
  
                                 T. F. Weaver  
  
                                 B. Combs  
  
                                 M. Lasslo

## **Request**

Inez Power LLC (INEZ) has requested to interconnect generation to Kentucky Power's distribution system via their existing metering point for facilities at 900 Middle Fork/Wolfe Creek Rd, Debord KY served from the Inez circuit on the Dewey sub-station. INEZ has requested to operate their generation interconnected to the Kentucky Power distribution grid generating 6,800 kVA back on to the grid, thus requiring this impact study.

## **Disclaimer**

The results of this impact study apply only to the system as described in INEZ's attached Application for Interconnection with the American Electric Power Distribution System. INEZ will only generate a maximum of 6,800 KVA back on to Kentucky Power. INEZ updated one line shown below.

This review is limited to how operating the generation in parallel could affect Kentucky Power's transmission and distribution systems and equipment. INEZ is required to take all necessary steps to assure compliance with all laws, ordinances, building codes and any other applicable regulations. Kentucky Power granting approval of the requested connection is not an endorsement of a particular design nor does it assure that the design will accomplish its intended function.

INEZ is expected to understand and comply with all aspects of IEEE 1547, relating to operating distributed generation.

## Modeling and Assumptions

It is assumed that INEZ has received a copy of the Customer Guide to the Interconnection of Distributed Resources to the American Electric Power (AEP) Distribution System, a copy is attached for reference.

INEZ's preferred feed is from the Inez circuit fed from the Dewey 138 kV to 34 kV, 25 MVA station. This station has volt var optimization installed which is designed to reduce the operating voltage of the circuit – the expected voltage range seen at INEZ metering based on 120 V base is 119V to 125V.

INEZ is requesting to connect a single 9,056 KVA synchronous generator operating at 4.16 kV. The point of common coupling (PCC) is assumed to be at INEZ's existing primary metering point (pole # 38830862C10025 – GPS 37.768542, -82.602161). For circuit modeling, a 2100 foot line section was assumed between the metering and the 34 kV to 4 kV transformer. A 7,500 KVA 34.5 kV Y grounded to 4.16 kV delta transformer with 5.84 % impedance (per provided transformer data sheet) was shown at the end of the 2,100 foot line section and a 200 foot section of line was assumed from the transformer to the generator. Information used in modeling the generation equipment and the transformer was taken from INEZ's Application for Interconnection with the American Electric Power Distribution System and additional transformer data sheet supplied by INEZ.

## Analysis

### System conditions of concern are:

- A) System load flows under both light and peak load conditions.
- B) Generator fault contribution during parallel operations.
- C) System voltage levels at light and maximum load conditions.
- D) Coordination with existing devices for fault conditions.

### System Load Flows

The following effects were analyzed:

**Light Load:** Back feed on the Dewey Station was - 2,965 KVA.

For light load condition an estimated load of 4,204 KVA was used and applied to the system. Under these assumptions, the generator produces more power than the circuit's native load and a back feed of 2,965 KVA would be placed on the Dewey station.

As a worst case condition, it was assumed that the recloser on pole 38830838A40155 (this is the first device past INEZ's tap) was interrupted - this resulted in a peak back feed of 6,500 kVA or basically all of INEZ's generation into the station. This condition did not result in any adverse system concerns on either the distribution or transmission line.

**Peak Load:** No back feed on the station. INEZ's 6,800 KVA generation was absorbed by the circuit.

For peak load condition an estimated load of 22,427 KVA was used and applied to the system. Under these assumptions, the generator output was absorbed completely by the circuit.

### **Generator Fault contribution**

The present three phase bolted (LLL) and line to ground (LG) faults at INEZ's metering are 1,770 amps and 2,141 amps respectfully. At full load generation, these values increase to 2,434 amps LLL and 2,856 amps LG. At the substation the faults increase from 2,794 to 3,379 amps LLL and 3,131 to 3,673 amps LG. The increased fault currents and load require the replacement of several protective devices which will have fault interruption ratings below the available fault current or full load current ratings that are insufficient to carry the load when INEZ's generation is connected to the Kentucky Power T&D system. These devices are listed in the Facilities section at the end of this report.

### **System Voltage Levels**

The generator had virtually no effect on the voltage at the station. At INEZ's metering the voltage rose roughly 2 volts from 124 V to 126V at light load with the station voltage at 125 V.

No voltage concerns were noted on the circuit.

### **Coordination with existing devices**

Presently the tap feeding INEZ is protected by 3 – 30 amp T fuses, these fuses will no longer be adequate to serve the load and must be replaced with a Viper recloser. An additional Viper recloser with voltage sensing on both the source and load side must be placed at INEZ's metering point to provide coordination with the upstream recloser.

The introduction of the generator increases available fault current from below 1500 amps to above 1500 amps for roughly 10,500 feet of three phase line and 7,200 feet of single phase line. This affects 52 existing transformers and a capacitor bank and will require current limiting fuses to be installed at each location.

Increased fault currents did not affect interrupting capabilities of the upstream or downstream reclosers currently on the circuit, so no changes to those devices were required.

## **System Protection**

INEZ's responsibilities include providing adequate protection to Kentucky Power facilities due to events arising from the operation of the generation in parallel under all Kentucky Power distribution system operating conditions. INEZ is responsible for protecting their own facilities under all Kentucky Power distribution system operating conditions whether the generation is connected to Kentucky Power facilities or not, including but not limited to conditions noted below:

- 1) Abnormal voltage or frequency
- 2) Loss of a single phase of supply
- 3) Equipment failure
- 4) Distribution system faults
- 5) Lightning
- 6) Excessive harmonic voltages
- 7) Excessive negative sequence voltages
- 8) Separation from supply
- 9) Loss of synchronization

IEEE Standard 1547-2003 "Standard for Interconnecting Distributed Resources with Electric Power Systems" provide the interconnection technical requirements for system protection for which INEZ is responsible.

The interconnection system hardware and software used by a Distributed Resource to meet the technical requirements do not have to be located at the Point of Common Coupling. However, the technical requirements shall be met at the Point of Common Coupling.

## **Testing**

INEZ shall test the distributed generation facilities to verify that all the requirements for IEEE 1547 are met. The proposed test plan and independent third party verification shall be agreed upon by Kentucky Power prior to the start of testing. The results shall be submitted to Kentucky Power in a format as indicated in the attached AEP Guide for Testing and Reporting per IEEE 1547.1. If the test results show non-compliance, INEZ must remedy the issue, retest, and submit the new results to Kentucky Power prior to operating the generation in a connected state.

## **Summary**

The contents of this impact study apply only to the unit described in the interconnection application submitted by INEZ for a DG interconnection on Kentucky Power's Dewy/Inez 34 kV distribution circuit near Debord, KY.

The cost of any damage resulting from a system condition caused by the installation and/or operation of the generation will be borne by INEZ.

Abnormal Utility events will be addressed on an individual basis through the AEP system operator. Corrective action shall be based on the judgment of the AEP system operator. Possible corrective action can include but is not limited to DG isolation from the Utility.

This review has been limited to items which may affect the Kentucky Power system or to suggestions which may improve operations. INEZ must take all necessary steps to assure compliance with all laws, ordinances, building codes and other applicable regulations. Approval of this connection by Kentucky Power, when granted, is not an endorsement of a particular design nor does it assure fitness to accomplish an intended function.

Any additional Kentucky Power work to mitigate power quality issues not foreseen by this study but associated with the interconnection will be at the sole cost and expense of INEZ.

Kentucky Power will require communication to INEZ's generation in order to monitor connection status, real power output, reactive power output and voltage as indicated in IEEE 1547 section 4.1.6.

## **Facilities**

The proposed generation interconnection will require the following improvements:

### **Generation driven:**

Replace 3 – 30 amp T fuses with a Viper recloser and control.

Install a new Viper recloser and control at metering point with source and load side voltage sensing.

Add current limiting fuses for one capacitor bank and 52 transformers.

Replace metering equipment with larger capacity and SCADA compliant device.

Install telecommunications equipment required for SCADA.

Total cost estimated at \$205,379.

### **Loading:**

No line loading improvements are needed at 6,800 kVA beyond those noted above.

Attachments:

INEZ's - Application for Interconnection with the American Electric Power Distribution System.

Customer Guide to interconnection of Distributed Resources to the American Electric Power (AEP) Distribution System

AEP Guide for Testing and Reporting per IEEE 1547.1

EXHIBIT C

## Cogeneration and/or Small Power Production Application

Customer's Name: Inez Power

Service Address: 900 Middle Fork Wolfe Creek Rd

City: Debord State: KY Zip Code: 41224

Account Number: \_\_\_\_\_

Telephone Number: 606.298.5007 E-mail Address: mayblocke@bellsouth.net

Contact Person (if different than Customer): Lee Bazzle

Address: 450 Sedgewick Rd

City: Summersville State: SC Zip Code: 29483

Telephone Number: 843.817.8383 E-mail Address: leebazzle@gmail.com

This application is for electric service under the Kentucky Power Company ("Company") Tariff COGEN/SPP II (Cogeneration and/or Small Power Production – Over 100 KW) for the above customer ("Customer"). Under Section 210 of the Public Utility Regulatory Policies Act of 1978 (PURPA), the Customer qualifies for Tariff COGEN/SPP II. The generating facility is located on the Customer's premises (located at the same address as Customer's account) and will operate in parallel with the Company's transmission and distribution systems. The Customer must complete an interconnection application and receive approval to interconnect in order to qualify for Tariff COGEN/SPP II. An Interconnection Agreement must be secured and the Customer's equipment must be inspected before the generator may deliver energy to the Company and take electric service under Tariff COGEN/SPP II.

The Customer-generator facility qualifies for Tariff COGEN/SPP II as it is a waste type generator, which is one of those qualifying facilities identified in PURPA. The Customer has provided the Company with a copy of its Federal Energy Regulatory Commission certification as a Qualifying Cogeneration Facility or Qualifying Small Power Production Facility under Section 210 of PURPA. The total rated generating capacity of the Customer-generator to be used and billed under Tariff COGEN/SPP II is 500 kW.

The Customer has selected Option 2 under this schedule:

Option 1 - The Customer does not sell any energy to the Company, and purchases from the Company its net load requirements, as determined by appropriate meters located at one delivery point.

Option 2 - The Customer sells to the Company the energy and average on-peak capacity produced by the Customer's qualifying COGEN/SPP facilities in excess of the Customer's total load, and purchases from the Company its net load requirements, as determined by appropriate meters located at one delivery point.

Option 3 - The Customer sells to the Company the total energy and average on-peak capacity produced by the Customer's qualifying COGEN/SPP facilities, while simultaneously purchasing from the Company its total load requirements, as determined by appropriate meters located at one delivery point.

## Cogeneration and/or Small Power Production Application

The Customer has selected the following Metering and Compensation Option 1 under this schedule:

1. Standard Meter – All kWh
  - a. 3.24 cents per kWh for all kWh delivered to the Company; and
  - b. \$3.11 per kW per month, times the lowest of:
    - i. Monthly contract capacity; or
    - ii. Current month metered average capacity (kWh delivered to the Company in a the billing month divided by 730); or
    - iii. Lowest average capacity metered during the previous two months if less than monthly contract capacity
2. Time of Day (“T.O.D.”) Meter
  - a. 3.86 cents per on-peak kWh delivered to the Company and 2.79 cents per off-peak kWh delivered to the Company
  - b. \$7.47 per kW per month, times the lowest of:
    - i. On-peak contract capacity; or
    - ii. Current month on-peak metered average capacity (kWh delivered to the Company in a the billing month divided by 305); or
    - iii. Lowest on-peak average capacity metered during the previous two months if less than monthly contract capacity

The Customer acknowledges that it has read the Company’s Tariff COGEN/SPP II and agrees to all terms and conditions contained therein. Specifically, the Customer understands and agrees that a meter, which is capable of registering the flow of electricity in each direction, must be in service at the facility. The Customer further accepts responsibility for interconnection costs and the Local Facilities Charge. The Customer and the Company shall execute a separate agreement detailing the charges and terms and conditions of payment of any such interconnection costs or Local Facilities Charge required for the Customer to take service from the Company under the terms of Tariff COGEN/SPP II.

Requested By:

Edward Lee Barz  
Customer Name (Print)

E. Lee Barz  
Authorized Signature

8/23/19  
Date

Approved By:

KENNETH L BORDERS  
Name (Print)

Kenneth L Borders  
Company Signature

1/31/20  
Date

Rejected By:

\_\_\_\_\_  
Name (Print)

## Cogeneration and/or Small Power Production Application

---

Company Signature

---

Reason for Rejection

---

Date