

E007 Special Access Service
(E7.1-E7.3)

E7. SPECIAL ACCESS (A.K.A. BELLSOUTH SPA) SERVICE

CONTENTS

E7.1	General	1	
E7.1.1	Channel Types	1	
E7.1.2	Rate Categories	2	
E7.1.3	Service Configurations	3.2	
E7.1.4	Alternate Use	6	
E7.1.5	Special Facilities Routing	6	
E7.1.6	Design Layout Report	6	
E7.1.7	Acceptance Testing	6	
E7.1.8	Ordering Options And Conditions	6	
E7.2	Service Descriptions	7	
E7.2.1	Metallic (a.k.a. BellSouth SPA Metallic) Service	8	
E7.2.2	Telegraph Grade (a.k.a. BellSouth SPA Telegraph) Service	9	
E7.2.3	Voice Grade (a.k.a. BellSouth SPA DS0 VG) Service	9	
E7.2.4	Reserved For Future Use	15	(T)
E7.2.5	Reserved For Future Use	17	
E7.2.6	Reserved For Future Use	19	
E7.2.7	Digital Data Access (a.k.a. BellSouth SPA DS0 Digital Data) Service	19	
E7.2.8	High Capacity (a.k.a. BellSouth SPA High Capacity) Service	22	
E7.2.9	Reserved for Future Use	22	
E7.2.10	Reserved for Future Use	22	
E7.2.11	Reserved for Future Use	22	
E7.2.12	Reserved for Future Use	22	
E7.2.13	Reserved for Future Use	22	
E7.2.14	(DELETED)	22.1	
E7.2.15	Derived Data Channel (a.k.a. BellSouth SPA Derived Data Channel) Service	22.2	
E7.2.16	SMARTRing service (a.k.a. BellSouth Dedicated Ring)	22.4	
E7.2.17	Reserved For Future Use	22.5	
E7.2.18	BellSouth Metro Ethernet Service	22.6	
E7.3	Channel Interface And Network Channel Codes	23	
E7.3.1	Glossary Of Channel Interface Codes And Options	23	
E7.3.2	Impedance	26	
E7.3.3	Digital Hierarchy Channel Interface Codes (4DS)	27	
E7.3.4	Service Designator/Network Channel Code Conversion Table	27	
E7.3.5	Reserved For Future Use	30	

**KENTUCKY
PUBLIC SERVICE COMMISSION**

Linda C. Bridwell
Executive Director

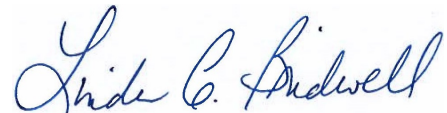

EFFECTIVE

1/1/2023

PURSUANT TO 807 KAR 5:011 SECTION 9 (1)

E7. SPECIAL ACCESS (A.K.A. BELLSOUTH SPA) SERVICE

CONTENTS

E7.4	Rate Regulations	49	
E7.4.1	Types Of Rates And Charges	49	
E7.4.2	Surcharge For Special Access (a.k.a. BellSouth SPA) Service	50.1	
E7.4.3	Message Station Equipment Recovery charge	52	
E7.4.4	Minimum Periods	52	
E7.4.5	Moves	53	(C)
E7.4.6	Mileage Measurement	53.1	(C)
E7.4.7	Facility Hubs	54	
E7.4.8	Shared Use Analog And Digital High Capacity (a.k.a. BellSouth SPA High Capacity) Service	55	
E7.4.9	Bijurisdictional WATS Access Line (a.k.a. BellSouth SPA WATS Line)"1+" and "0" IntraLATA Usage	55.1	
E7.4.10	Reserved For Future Use	55.1	
E7.4.11	Reserved For Future Use	55.1	
E7.4.12	FlexServ Service (a.k.a. BellSouth SPA Customer Reconfiguration)	55.1	
E7.4.13	Derived Data Channel Service	55.4	
E7.4.14	SMARTRing service (a.k.a. BellSouth Dedicated Ring)	55.4	
E7.4.15	Zone Pricing	55.7	
E7.4.16	Reserved for Future Use	55.7	
E7.4.17	Reserved For Future Use	55.7.1	
E7.4.18	Reserved For Future Use	55.7.1	
E7.4.19	Reserved For Future Use	55.7.1	
E7.4.20	Reserved For Future Use	55.7.1	
E7.4.21	Reserved For Future Use	55.7.1	
E7.4.22	Reserved For Future Use	55.7.1	
E7.4.23	Reserved For Future Use	55.7.1	
E7.4.24	Reserved For Future Use	55.7.1	
E7.4.25	Reserved For Future Use	55.7.1	
E7.4.26	Reserved For Future Use	55.7.1	
E7.4.27	Reserved For Future Use	55.7.1	
E7.4.28	Reserved For Future Use	55.7.1	
E7.4.29	Reserved For Future Use	55.7.1	
E7.4.30	Reserved For Future Use	55.7.1	
E7.4.31	Reserved For Future Use	55.7.1	
E7.4.32	BellSouth Metro Ethernet Service	55.7.2	

**KENTUCKY
PUBLIC SERVICE COMMISSION**

Linda C. Bridwell
Executive Director



EFFECTIVE

12/1/2021

PURSUANT TO 807 KAR 5:011 SECTION 9 (1)

E7. SPECIAL ACCESS (A.K.A. BELLSOUTH SPA) SERVICE

CONTENTS

E7.5 Rates And Charges	55.8	
E7.5.1 Metallic (a.k.a. BellSouth SPA Metallic) Service	55.8	
E7.5.2 Telegraph Grade (a.k.a. BellSouth SPA Telegraph) Service	56	
E7.5.3 Voice Grade (a.k.a. BellSouth SPA DS0 VG) Service	57	
E7.5.4 Reserved For Future Use	61	(T)
E7.5.5 Reserved For Future Use	62	
E7.5.6 Reserved For Future Use	64	
E7.5.7 Digital Data Access (a.k.a. BellSouth SPA DS0 Digital Data) Service	66	
E7.5.8 High Capacity (a.k.a. BellSouth SPA High Capacity) Service	68	
E7.5.9 Message Station Equipment Recovery Charge	71.1	
E7.5.10 Special Access (a.k.a. BellSouth SPA) Surcharge	71.1	
E7.5.11 Reserved For Future Use	71.1	
E7.5.12 Reserved For Future Use	71.1	
E7.5.13 Transfer of Service	71.1	
E7.5.14 Reserved for Future Use	71.2	
E7.5.15 Derived Data Channel (a.k.a. BellSouth SPA Derived Data Channel) Service	73	
E7.5.16 FlexServ Service (a.k.a. BellSouth SPA Customer Reconfiguration)	73	
E7.5.17 SMARTRing service (a.k.a. BellSouth Dedicated Ring)	73.0.2	
E7.5.18 Reserved For Future Use	73.0.5	
E7.5.19 Reserved For Future Use	73.0.5	
E7.5.20 Reserved For Future Use	73.0.6	
E7.5.21 Reserved For Future Use	73.0.6	
E7.5.22 BellSouth Metro Ethernet Service	73.0.6	
E7.6 ICB Rates And Charges	73.1	
E7.7 Custom Network Service (a.k.a. BellSouth Custom Network Service)	73	
E7.7.1 General	73	
E7.7.2 Custom Network Service Arrangement I	73.1	
E7.7.3 Custom Network Service Arrangement II	76	

**KENTUCKY
PUBLIC SERVICE COMMISSION**

Linda C. Bridwell
Executive Director

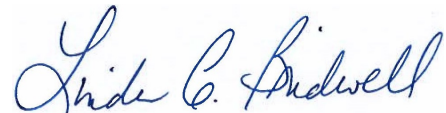

EFFECTIVE

1/1/2023

PURSUANT TO 807 KAR 5:011 SECTION 9 (1)

E7. SPECIAL ACCESS (A.K.A. BELLSOUTH SPA) SERVICE

E7.1 General

Special Access (a.k.a. BellSouth SPA) service provides a transmission path to connect customer designated premises¹, either directly or through a Company hub where bridging or channelization functions are performed. Special Access (a.k.a. BellSouth SPA) service² includes all exchange access not utilizing Company end office switches.

The connections provided by Special Access (a.k.a. BellSouth SPA) service can be either analog or digital. Analog connections are differentiated by spectrum and bandwidth. Digital connections are differentiated by bit rate.

E7.1.1 Channel Types

- A. There are nine types of channels used to provide Special Access (a.k.a. BellSouth SPA) services. Each type has its own characteristics. All are subdivided by one or more of the following:
- Transmission specifications
 - Bandwidth
 - Speed (i.e., bit rate)
 - Spectrum
- B. Customers can order a basic channel and select from a list of available transmission parameters and channel interfaces, those that they desire to meet specific communications requirements.
- C. For purposes of ordering channels, each has been identified as a type of Special Access (a.k.a. BellSouth SPA) service. However, such identification is not intended to limit a customer's use of the channel nor to imply that the channel is limited to a particular use. For example, if a customer's equipment is capable of transmitting voice over a channel that is identified as Metallic⁴ (a.k.a. BellSouth SPA Metallic) service in this Tariff, there is no restriction against doing so.
- D. Following is a brief description of each type of channel:
1. Metallic⁴ (a.k.a. BellSouth SPA Metallic) - a channel for the transmission of low speed varying signals at rates up to 30 baud.
 2. Telegraph (a.k.a. BellSouth SPA Telegraph) Grade⁴ - a channel for the transmission of binary signals at rates of 0 to 75 baud or 0 to 150 baud.
 3. Voice Grade⁴ (a.k.a. BellSouth SPA DS0 VG) - a channel for the transmission of analog signals within an approximate bandwidth of 300-3000 Hz.
 4. WATS Access Line⁴ (a.k.a. BellSouth SPA WATS Line) (WAL) - a channel from a customer designated premises to a WATS serving office for 800, WATS or similar service.
 5. **(DELETED)**
 6. **(DELETED)**
 7. Digital Data Access⁴ (a.k.a. BellSouth SPA DS0 Digital Data) - a channel for the digital transmission of synchronous serial data at rates of 2.4, 4.8, 9.6 or 56.0 kbps.
 8. High Capacity (a.k.a. BellSouth SPA High Capacity) - a channel for the transmission of isochronous serial digital data at rates of 1.544, 3.152, 6.312, or 44.736 Mbps.
 9. Derived Data Channel⁴ (a.k.a. BellSouth SPA Derived Data Channel) - a digital data channel derived from a two-wire local exchange facility that transmits voice and data signals simultaneously.

Note 1: Company-provided Centrex Type Services systems and Company Answering Service Concentrators are considered to be customer premises for purposes of administering regulations and rates contained in this Tariff.

Note 2: For purposes of administering the surcharge regulations, WATS access lines (a.k.a. BellSouth SPA WATS Line) are considered to be Special Access (a.k.a. BellSouth SPA) service.

Note 3: **(DELETED)**

Note 4: Effective June 30, 2021, this Service will no longer be available for purchase by new or existing customers. In addition, requests to move, add, change, or renew existing service arrangements will not be accepted. Following the expiration of a customer's existing term agreement, service will be provided on a month-to-month basis at the applicable Monthly rates until the service is discontinued. The Company currently plans to discontinue this service on or after June 30, 2024.

**KENTUCKY
PUBLIC SERVICE COMMISSION**
Linda C. Bidwell
Executive Director

EFFECTIVE
1/1/2023
PURSUANT TO 807 KAR 5:011 SECTION 9 (1)

E7. SPECIAL ACCESS (A.K.A. BELLSOUTH SPA) SERVICE

E7.1 General (Cont'd)

E7.1.1 Channel Types (Cont'd)

Detailed descriptions of each of the channel types are provided in E7.2.

The customer also has the option of ordering digital high capacity facilities (i.e., 1.544 Mbps, 3.152 Mbps, 6.312 Mbps, and 44.736 Mbps) to a Company Hub for channelization to individual channels of a lower capacity. Descriptions of the types of channelization available at the hubs, as well as the number of individual channels which may be derived from each type of facility are set forth in E7.2. Additionally, the customer may specify optional features for the individual channels derived from the facility to further tailor the channel to meet specific communications requirements. Descriptions of the optional features and functions available are also set forth in E7.2.

For example, a customer may order a 44.736 Mbps facility from a customer designated premises to a Company Hub for channelization to twenty-eight 1.544 Mbps channels. The 1.544 Mbps channels may be further channelized at the same or a different Hub to Voice Grade¹ (a.k.a. BellSouth SPA DS0 VG) channels or may be extended to other customer designated premises. Optional features may be added to either the 1.544 Mbps or the Voice Grade¹ channels.

E7.1.2 Rate Categories

There are five basic rate categories which apply to Special Access (a.k.a. BellSouth SPA) service:

- Local Channels (described in E7.1.2.A)
- Interoffice Channel (described in E7.1.2.B)
- Optional Features and Functions (described in E7.1.2.C)
- SMARTRing^{®2} service (a.k.a BellSouth Dedicated Ring)

(C)

(M)

Note 1: Effective June 30, 2021, this Service will no longer be available for purchase by new or existing customers. In addition, requests to move, add, change, or renew existing service arrangements will not be accepted. Following the expiration of a customer's existing term agreement, service will be provided on a month-to-month basis at the applicable Monthly rates until the service is discontinued. The Company currently plans to discontinue this service on or after June 30, 2024.

Note 2: Effective on or after December 1, 2021, neither new nor existing customers will be permitted to purchase new SMARTRing Service (Service). In addition, (A) Service Payment Plans greater than 12-months in length will no longer be available; and (B) requests to move, add, change, upgrade, or downgrade existing service arrangements will not be accepted, with the following exceptions: (1) existing customers will be permitted to modify their existing Service and will be able to add new circuits to their existing Service, but will not be permitted to add new nodes in any locations; and (2) any such new circuits will be subject to the customer's existing term payment plan or term agreement for the Service to which they are added. Following the expiration of a customer's existing term agreement, Service will be provided on a month-to-month basis at the applicable Month-to-Month rates until the Service is discontinued.

(N)

Effective November 30, 2023, unless specified to the contrary in their existing Service agreements, existing customers may not renew Term Payment Plans or term agreements for Service. In addition, no move, add, or change orders of any type will be accepted.

(N)

**KENTUCKY
PUBLIC SERVICE COMMISSION**

Linda C. Bridwell
Executive Director



EFFECTIVE

12/1/2021

PURSUANT TO 807 KAR 5:011 SECTION 9 (1)

Material previously appearing on this page now appears on page(s) 2.1 of this section.

[®] Registered Service Mark of BellSouth Corporation

* Service Mark of BellSouth Corporation

E7. SPECIAL ACCESS (A.K.A. BELLSOUTH SPA) SERVICE

E7.1 General (Cont'd)

E7.1.2 Rate Categories (Cont'd)

A. Local Channel

The Local Channel rate category provides for the communications path between the demarcation point at a customer designated premises and the serving wire center of that premises. Included as part of the Local Channel is a standard channel interface arrangement which defines the technical characteristics associated with the type of facilities to which the access service is to be connected at the Point of Termination (POT) and the type of signaling capability, if any. The signaling capability itself is provided as an optional feature as set forth in E7.1.2.C. One Local Channel charge applies per customer designated premises at which the channel is terminated. This charge will apply even if the customer premises and the serving wire center are co-located in a Company building. A Hub Termination Charge applies in addition to each Digital Data Access¹ (a.k.a. BellSouth SPA DS0 Digital Data) service Local Channel.

(M)

B. Interoffice Channel

The Interoffice Channel rate category provides for the transmission facilities between the serving wire centers associated with two customer designated premises, between a serving wire center associated with a customer designated premises and a Company Hub or between two Company Hubs. Interoffice Channel mileage is portrayed in mileage bands. There are two rates that apply for each band, i.e., a flat rate per band and a rate per mile.

(M)

C. Optional Features and Functions

The Optional Features and Functions rate category provides for optional features and functions which may be added to a Special Access (a.k.a. BellSouth SPA) service to improve its quality or utility to meet specific communications requirements. These are not necessarily identifiable with specific equipment, but rather represent the end result in terms of performance characteristics which may be obtained. These characteristics may be obtained by using various combinations of equipment. Although the equipment necessary to perform a specified function may be installed at various locations along the path of the service, they will be charged for as a single rate element.

(M)

Note 1: Effective June 30, 2021, this Service will no longer be available for purchase by new or existing customers. In addition, requests to move, add, change, or renew existing service arrangements will not be accepted. Following the expiration of a customer's existing term agreement, service will be provided on a month-to-month basis at the applicable Monthly rates until the service is discontinued. The Company currently plans to discontinue this service on or after June 30, 2024.

(M)



E7. SPECIAL ACCESS (A.K.A. BELLSOUTH SPA) SERVICE

E7.1 General (Cont'd)

E7.1.2 Rate Categories (Cont'd)

C. Optional Features and Functions (Cont'd)

Examples of Optional Features and Functions that are available include, but are not limited to, the following:

- Signaling Capability
- Hubbing Functions
- Conditioning
- Transfer Arrangements
- FlexServ[®] service (a.k.a. BellSouth SPA Customer Reconfiguration)

A Hub is a Company designated serving wire center at which bridging or channelization functions are performed. The bridging functions performed are to connect three or more customer designated premises in a multipoint arrangement. The channelization functions are to channelize analog or digital facilities to individual services requiring a lower capacity. National Exchange Carrier Association Tariff FCC No. 4 identifies serving wire centers, Hub locations and the type of bridging or channelization functions available.

Descriptions for each of the available Optional Features and Functions are set forth in E7.2. following.

D. Self-healing Multi-nodal Alternate Route Topology Ring (SMARTRing[®] service [a.k.a. BellSouth Dedicated Ring]) (C)

1. Customer Node

Customer Nodes provide ring switching capabilities at customer designated locations other than Telephone Company Premises that are part of SMARTRing[®] service (a.k.a. BellSouth Dedicated Ring). This rate element offers OC-3, OC-3+, OC-12, OC-48, or OC-48+ network capacities. An OC-1 network capacity is available only in an Overlay Ring Arrangement riding the customer's host OC-12, OC-48, or OC-48+ SMARTRing[®] service (a.k.a. BellSouth Dedicated Ring) installed on or after June 3, 1994. A summary of the channel interfaces available with each node are specified in E7.2.16.A following.

2. Customer Channel Interface

A Customer Channel Interface provides DS1, DS3, STS-1 electrical channelization and/or OC-3 and/or OC-12 optical channelization that may take place at each Customer Node of SMARTRing[®] service (a.k.a. BellSouth Dedicated Ring). The Customer Channel Interface rate element applies for every interface capacity that originates or terminates at a Customer Node. A summary of the channel interfaces available with each node are specified in E7.2.16.A. following.

(M)

(N)

Note 1: Effective on or after December 1, 2021, neither new nor existing customers will be permitted to purchase new SMARTRing Service (Service). In addition, (A) Service Payment Plans greater than 12-months in length will no longer be available; and (B) requests to move, add, change, upgrade, or downgrade existing service arrangements will not be accepted, with the following exceptions: (1) existing customers will be permitted to modify their existing Service and will be able to add new circuits to their existing Service, but will not be permitted to add new nodes in any locations; and (2) any such new circuits will be subject to the customer's existing term payment plan or term agreement for the Service to which they are added. Following the expiration of a customer's existing term agreement, Service will be provided on a month-to-month basis at the applicable Month-to-Month rates until the Service is discontinued.

Effective November 30, 2023, unless specified to the contrary in their existing Service agreements, existing customers may not renew Term Payment Plans or term agreements for Service. In addition, no move, add, or change orders of any type will be accepted.

(N)

Material previously appearing on this page now appears on page(s) 3.0.1 of this section.

[®]Registered Service Mark of BellSouth Corporation



E7. SPECIAL ACCESS (A.K.A. BELLSOUTH SPA) SERVICE

E7.1 General (Cont'd)

E7.1.2 Rate Categories (Cont'd)

- D.** Self-healing Multi-nodal Alternate Route Topology Ring (SMARTRing[®] service [a.k.a. BellSouth Dedicated Ring]) (Cont'd) (C)
3. Central Office Node (M)
- Central Office Nodes provide ring switching capabilities at Telephone Company Central Offices that are a part of SMARTRing[®] service (a.k.a. BellSouth Dedicated Ring). This rate element offers OC-3, OC-3+, OC-12, OC-48, and OC-48+ network capacities. An OC-1 network capacity is available only in an Overlay Ring Arrangement riding the customer's host OC-12, OC-48 or OC-48+ SMARTRing[®] service (a.k.a. BellSouth Dedicated Ring) installed on or after June 3, 1994. A summary of the channel interfaces available with each node are specified in E7.2.16.A. following.
4. Central Office Channel Interface (M)
- A Central Office Channel Interface provides DS1, DS3, STS-1 electrical channelization and/or OC-3 and/or OC-12 optical channelization that may take place at each Central Office Node located on SMARTRing[®] service (a.k.a. BellSouth Dedicated Ring). The Central Office Channel Interface rate element applies for every interface capacity that originates or terminates at a Central Office Node. A summary of the channel interfaces available with each node are specified in E7.2.16.A. following. Customers with DS3 or STS-1 interfaces at the Customer Node electing to connect with DS1 services at a Central Office Node, must obtain a 28-DS1 Channel System.
5. Local Channel (M)
- The Local Channel rate category provides for the communications path between a Customer Node and the serving wire center of the premises where located. Charges for Local Channels apply as described in A. preceding. It is available with all capacities of SMARTRing[®] service (a.k.a. BellSouth Dedicated Ring) except OC-1.

Note 1: Effective on or after December 1, 2021, neither new nor existing customers will be permitted to purchase new SMARTRing Service (Service). In addition, (A) Service Payment Plans greater than 12-months in length will no longer be available; and (B) requests to move, add, change, upgrade, or downgrade existing service arrangements will not be accepted, with the following exceptions: (1) existing customers will be permitted to modify their existing Service and will be able to add new circuits to their existing Service, but will not be permitted to add new nodes in any locations; and (2) any such new circuits will be subject to the customer's existing term payment plan or term agreement for the Service to which they are added. Following the expiration of a customer's existing term agreement, Service will be provided on a month-to-month basis at the applicable Month-to-Month rates until the Service is discontinued. (N)

Effective November 30, 2023, unless specified to the contrary in their existing Service agreements, existing customers may not renew Term Payment Plans or term agreements for Service. In addition, no move, add, or change orders of any type will be accepted. (N)



E7. SPECIAL ACCESS (A.K.A. BELLSOUTH SPA) SERVICE

E7.1 General (Cont'd)

E7.1.2 Rate Categories (Cont'd)

- D. Self-healing Multi-nodal Alternate Route Topology Ring (SMARTRing¹ service [a.k.a. BellSouth Dedicated Ring])** (C)
6. **Alternate Central Office Channel**
The Alternate Central Office Channel provides for the communications path between a customer node and an alternate central office. It is available with all capacities of SMARTRing service (a.k.a. BellSouth Dedicated Ring) except OC-1.
7. **Interoffice Channel**
The Interoffice Channel provides for the communications path between directly connected Telephone Company central offices located on a SMARTRing service (a.k.a. BellSouth Dedicated Ring). It is available with all capacities of SMARTRing service (a.k.a. BellSouth Dedicated Ring) except OC-1. This rate element does not apply where Central Office Nodes are adjacently connected in the same Central Office on the same SMARTRing service (a.k.a. BellSouth Dedicated Ring) for the purpose of providing additional node capacity.
8. **Internodal Channel**
The Internodal Channel provides for the communications path between two directly connected Customer Nodes of a given SMARTRing service (a.k.a. BellSouth Dedicated Ring) located (a) in the same Serving Wire Center area or (b) in the same Office Park/Campus Environment or contiguous property, located in contiguous Serving Wire Center areas. It is available with all capacities of SMARTRing service (a.k.a. BellSouth Dedicated Ring) except OC-1. This rate element does not apply where Customer Nodes are adjacently connected in the same building on the same SMARTRing service (a.k.a. BellSouth Dedicated Ring) for the purpose of providing additional node capacity.
9. **Channel Interface Capacity Reallocation**
Channel Interface Capacity Reallocation allows the customer to reallocate STS-1, DS3 capacity interfaces at each node subsequent to the initial service installation.
- E. Reserved for Future Use**
- F. Access Collocation Cross-Connects**
Access Collocation Cross-Connects provide a means for customers to interconnect their Shared Use and Digital High Capacity (a.k.a. BellSouth SPA High Capacity) to Central Office Collocation arrangements within the same Central Office. Terms, conditions, and rates for Physical Access Collocation Cross-Connects and Virtual Access Collocation Cross-Connects are set forth in Section E13. of this Tariff.

Note 1: Effective on or after December 1, 2021, neither new nor existing customers will be permitted to purchase new SMARTRing Service (Service). In addition, (A) Service Payment Plans greater than 12-months in length will no longer be available; and (B) requests to move, add, change, upgrade, or downgrade existing service arrangements will not be accepted, with the following exceptions: (1) existing customers will be permitted to modify their existing Service and will be able to add new circuits to their existing Service, but will not be permitted to add new nodes in any locations; and (2) any such new circuits will be subject to the customer's existing term payment plan or term agreement for the Service to which they are added. Following the expiration of a customer's existing term agreement, Service will be provided on a month-to-month basis at the applicable Month-to-Month rates until the Service is discontinued. (N)

Effective November 30, 2023, unless specified to the contrary in their existing Service agreements, existing customers may not renew Term Payment Plans or term agreements for Service. In addition, no move, add, or change orders of any type will be accepted. (N)

**KENTUCKY
PUBLIC SERVICE COMMISSION**

Linda C. Bridwell
Executive Director



EFFECTIVE

12/1/2021

PURSUANT TO 807 KAR 5:011 SECTION 9 (1)

ISSUED: December 7, 1998
BY: E.C. Roberts, Jr., President - KY
Louisville, Kentucky

EFFECTIVE: January 6, 1999

E7. SPECIAL ACCESS (A.K.A. BELLSOUTH SPA) SERVICE

E7.1 General (Cont'd)

(N)

E7.1.3 Service Configurations

(M)

There are three types of service configurations over which Special Access (a.k.a. BellSouth SPA) services are provided: two-point service and multipoint service.

(M)

A. Two-Point Service

(M)

A two-point service connects two customer designated premises, either on a directly connected basis or through a hub where channelization functions are performed.

(M)

Applicable rate elements are:

(M)

- Local Channels

(M)

- Interoffice Channels (as applicable)

(M)

- Optional Features and Functions (when applicable)

(M)

In addition, a Special Access (a.k.a. BellSouth SPA) Surcharge as set forth in E7.4.2 following and a Message Station Equipment Recovery Charge as set forth in E7.4.3 following may be applicable.

(M)

PUBLIC SERVICE COMMISSION
KENTUCKY
CINCINNATI

JAN 06 1999

PUBLIC SERVICE COMMISSION
KENTUCKY
CINCINNATI

RECEIVED
PUBLIC SERVICE COMMISSION
KENTUCKY
CINCINNATI

Material appearing on this page previously appeared on page(s) 3.1 of this section.

E7. SPECIAL ACCESS (A.K.A. BELLSOUTH SPA) SERVICE

E7.1 General (Cont'd)

E7.1.3 Service Configurations (Cont'd)

A. Two-Point Service (Cont'd)

The following diagram depicts a two-point Voice Grade¹ (*a.k.a. BellSouth SPA DS0 VG*) service connecting two customer designated premises located 15 miles apart. The service is provided with C-Type Conditioning. (C)

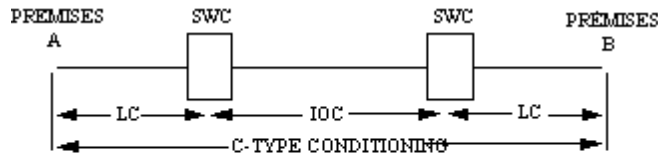

LC - Local Channel
 IOC - Interoffice Channel
 SWC - Serving Wire Center

Applicable rate elements are:

- Local Channels (2 applicable)
- Interoffice Channels (mileage band over 9 thru 25 miles)
- C-Type conditioning Optional Feature

B. Multipoint Service

Multipoint service connects three or more customer designated premises through a Company Hub. There is no limitation on the number of mid-links available with multipoint service. However, when more than three mid-links are provided in tandem, the quality of the service may be degraded. A mid-link is a channel between hubs (i.e., bridging locations). Only certain types of Special Access (*a.k.a. BellSouth SPA*) service are provided as multipoint service. These are so designated in the Service Descriptions set forth in E7.2. following.

When ordering, the customer will specify the desired bridging Hub(s) selected from the Exchange Carrier Association Tariff F.C.C. No. 4. This tariff identifies the type(s) of bridging functions which are available and the serving wire centers at which they are available.

Applicable Rate Elements are:

- Local Channels (one per customer designated premises)
- Interoffice Channels (as applicable between each designated customer premises and the Hub and between Hubs)
- Bridging
- Additional Optional Features (when applicable)

Note 1: Effective June 30, 2021, this Service will no longer be available for purchase by new or existing customers. In addition, requests to move, add, change, or renew existing service arrangements will not be accepted with the expiration of a customer's existing term agreement, service will be provided on a month-to-month basis at the applicable monthly rates until the service is discontinued. The Company currently plans to discontinue this service.

**KENTUCKY
 PUBLIC SERVICE COMMISSION**

Linda C. Bidwell
 Linda C. Bidwell
 Executive Director

**EFFECTIVE
 6/30/2021
 PURSUANT TO 807 KAR 5:011 SECTION 9 (1)**

(N)
 |
 (N)

E7. SPECIAL ACCESS (A.K.A. BELLSOUTH SPA) SERVICE

E7.1 General (Cont'd)

E7.1.3 Service Configurations (Cont'd)

B. Multipoint Service (Cont'd)

In addition, a Special Access (a.k.a. BellSouth SPA) Surcharge as set forth in E7.4.2. following and a Message Station Equipment Recovery Charge as set forth in E7.4.3. following may be applicable.

Example: Voice Grade¹ (a.k.a. BellSouth SPA DS0 VG) multipoint connecting four customer premises via two customer specified bridging hubs. (C)

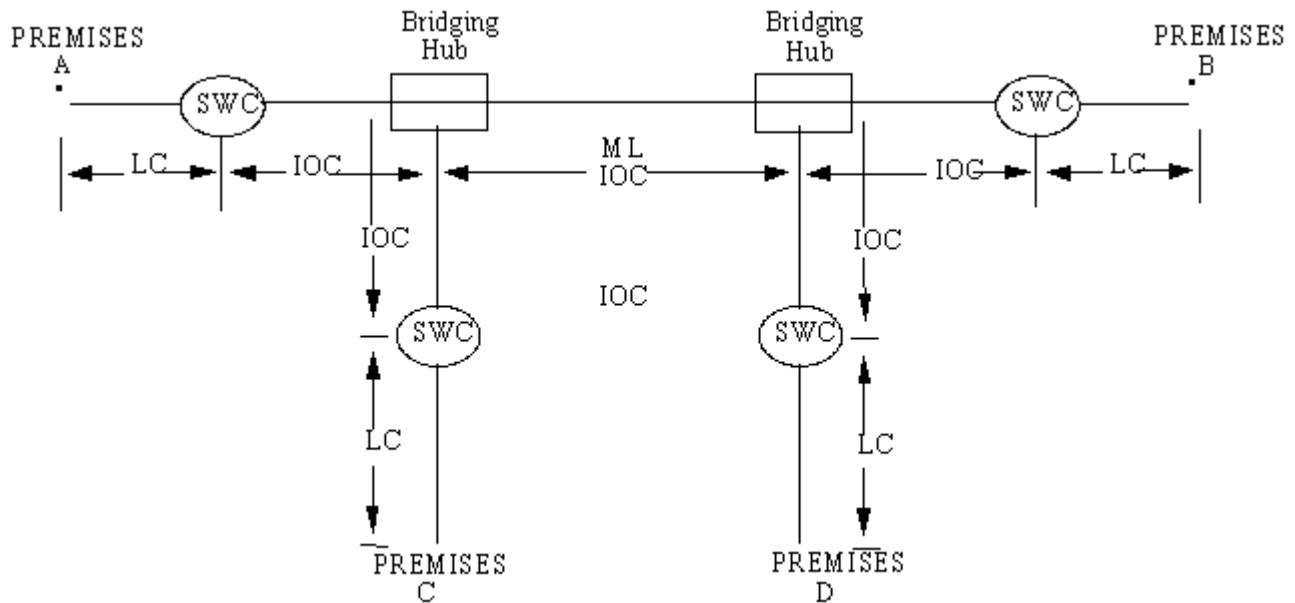

LC = Local Channel
 IC = Interoffice Channel
 B = Bridging
 SWC = Serving Wire Center

Applicable rate elements are:

- Local Channels (4 applicable)
- Interoffice Channel (5 sections, each from appropriate mileage band)
- Bridging Optional Feature (6 applicable, i.e., each bridge port)

Note 1: Effective June 30, 2021, this Service will no longer be available for purchase by new or existing customers. In addition, requests to move, add, change, or renew existing service arrangements will not be accepted. Following the expiration of a customer's existing term agreement, service will be provided on a month-to-month basis until the service is discontinued. The Company currently plans to discontinue this service.

**KENTUCKY
PUBLIC SERVICE COMMISSION**

Linda C. Bridwell
Executive Director

Linda C. Bridwell

**EFFECTIVE
6/30/2021**

PURSUANT TO 807 KAR 5:011 SECTION 9 (1)

(N)
 |
 (N)

E7. SPECIAL ACCESS (A.K.A. BELLSOUTH SPA) SERVICE

E7.1 General (Cont'd)

E7.1.3 Service Configurations (Cont'd)

C. SMARTRing[®] service (a.k.a. BellSouth Dedicated Ring)

1. The SMARTRing[®] service (a.k.a. BellSouth Dedicated Ring) configuration utilizes a multi-nodal ring architecture which is specified jointly by the Company and the customer. The minimum configuration provides dedicated DS3 and/or DS1 digital services and must include at least three nodes. The three nodes may all be Central Office Nodes in Telephone Company Central Offices, or the three nodes may be a Central Office Node in a Telephone Company Central Office, a Customer Node at a customer's designated location and the third node may be either a Central Office Node or a node at another customer designated location. Additional nodes for either arrangement may be any combination thereof. The maximum number of nodes will be determined based on equipment capability. The nodes are connected by SMARTRing[®] service (a.k.a. BellSouth Dedicated Ring) Local Channels, Alternate Central Office Channels, Interoffice Channels and Internodal Channels as applicable. SMARTRing[®] service (a.k.a. BellSouth Dedicated Ring) may be connected to other DS3/DS1 services only at Central Office Nodes. With OC-12 SMARTRing[®] service (a.k.a. BellSouth Dedicated Ring) installed on or after June 3, 1994, and with OC-48 and OC-48+ SMARTRing[®] service (a.k.a. BellSouth Dedicated Ring) the customer may request an OC-1 and/or OC-3 Overlay Ring Arrangement riding the customer's host OC-12, OC-48, or OC-48+ SMARTRing[®] service (a.k.a. BellSouth Dedicated Ring). With OC-48 SMARTRing[®] service (a.k.a. BellSouth Dedicated Ring), the customer may request an OC-3+ and/or OC-12 Overlay Ring Arrangement riding the customer's host OC-48 SMARTRing[®] service (a.k.a. BellSouth Dedicated Ring). In an Overlay Ring Arrangement, node and channel configuration requirements apply to the host SMARTRing[®] service (a.k.a. BellSouth Dedicated Ring).
2. Applicable rate elements for this service are:
 - a. Customer Node (at least one for configurations other than three Central Office Node arrangement)
 - b. Customer Channel Interface (one for each originating/terminating activated DS1, DS3, STS-1, OC-3, and/or OC-12 for each Customer Node)
 - c. Central Office Node (at least one for configurations other than three Central Office Node arrangement)
 - d. Central Office Channel Interface (one for each originating/terminating activated DS1, DS3, STS-1, OC-3 and/or OC-12 for each Central Office Node or one for each 28 DS1 Channel System and associated DS1 Channel Interfaces for each activated DS3)
 - e. Local Channel (at least one for each Customer Node which is directly connected to the serving wire center)
 - f. Alternate Central Office Channel (at least one for each Customer Node which is directly connected to an Alternate Central Office)
 - g. Internodal Channel (one for each path between two directly connected customer nodes)
 - h. Interoffice Channel (one for each path between each two directly connected Telephone Company Central Offices)
 - i. Channel Interface Capacity Reallocation (one per node per occurrence)

Note 1: Effective on or after December 1, 2021, neither new nor existing customers will be permitted to purchase new SMARTRing Service (Service). In addition, (A) Service Payment Plans greater than 12-months in length will no longer be available; and (B) requests to move, add, change, upgrade, or downgrade existing service arrangements will not be accepted, with the following exceptions: (1) existing customers will be permitted to modify their existing Service and will be able to add new circuits to their existing Service, but will not be permitted to add new nodes in any locations; and (2) any such new circuits will be subject to the customer's existing term payment plan or term agreement for the Service to which they are added. Following the expiration of a customer's existing term agreement, Service will be provided on a month-to-month basis at the applicable Month-to-Month rates until the Service is discontinued.

Effective November 30, 2023, unless specified to the contrary in their existing Service agreements, existing customers may not renew Term Payment Plans or term agreements for Service. In addition, no move, add, or change orders of any type will be accepted.

**KENTUCKY
PUBLIC SERVICE COMMISSION**

Linda C. Bridwell
Executive Director



EFFECTIVE

12/1/2021

PURSUANT TO 807 KAR 5:011 SECTION 9 (1)

E7. SPECIAL ACCESS (A.K.A. BELLSOUTH SPA) SERVICE

E7.1 General (Cont'd)

E7.1.3 Service Configurations

C. SMARTRing[®] service (a.k.a. BellSouth Dedicated Ring) (Cont'd)

(C)

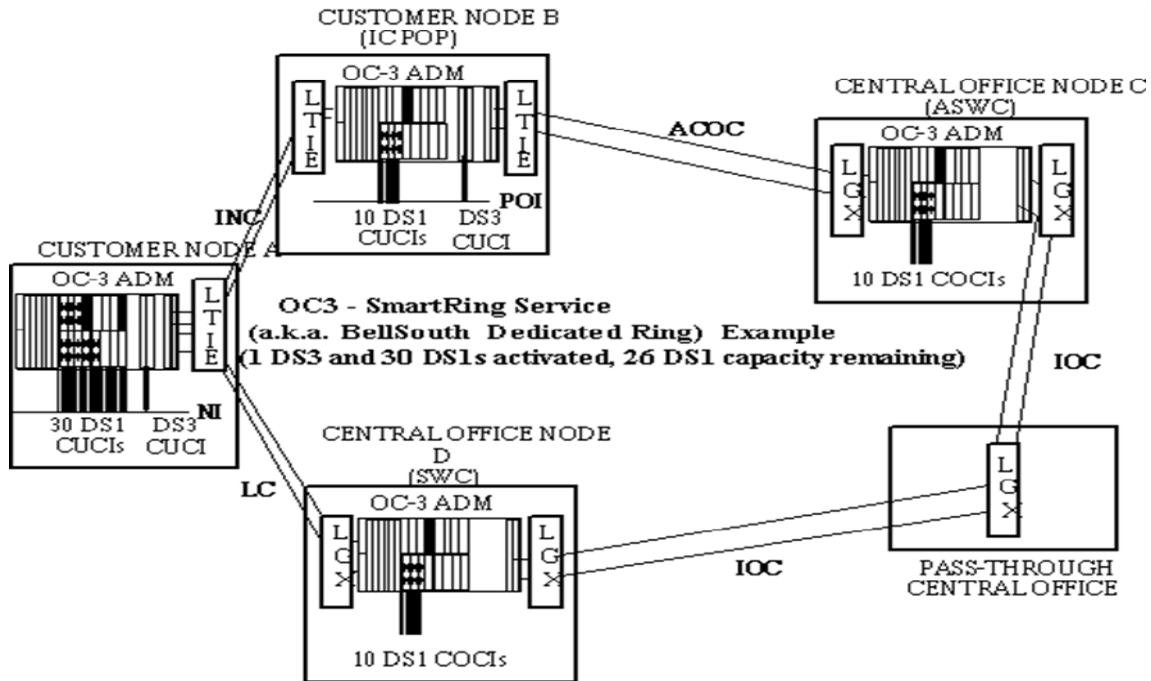

Example: SMARTRing[®] service (a.k.a. BellSouth Dedicated Ring) OC-3 capacity.

For this example the following rate elements are applicable:

(C)

- 2 Customer Nodes
- 1 Internodal Channel
- 1 Alternate Central Office Channel
- 2 Central Office Nodes
- 2 Interoffice Channels
- 2 DS3 Customer Channel Interfaces
- 1 Local Channel
- 40 DS1 Customer Channel Interfaces
- 20 DS1 Central Office Channel Interfaces

Note 1: Effective on or after December 1, 2021, neither new nor existing customers will be permitted to purchase new SMARTRing Service (Service). In addition, (A) Service Payment Plans greater than 12-months in length will no longer be available; and (B) requests to move, add, change, upgrade, or downgrade existing service arrangements will not be accepted, with the following exceptions: (1) existing customers will be permitted to modify their existing Service and will be able to add new circuits to their existing Service, but will not be permitted to add new nodes in any locations; and (2) any such new circuits will be subject to the customer's existing term payment plan or term agreement for the Service to which they are added. Following the expiration of a customer's existing term agreement, Service will be provided on a month-to-month basis at the applicable Month-to-Month rates until the Service is discontinued.

(N)

Effective November 30, 2023, unless specified to the contrary in their existing Service agreements, existing customers may not renew Term Payment Plans or term agreements for Service. In addition, no move, add, or change orders of any type will be accepted.

(N)

**KENTUCKY
 PUBLIC SERVICE COMMISSION**

Linda C. Bridwell
 Executive Director



**EFFECTIVE
 12/1/2021**

PURSUANT TO 807 KAR 5:011 SECTION 9 (1)

E7. SPECIAL ACCESS (A.K.A. BELLSOUTH SPA) SERVICE

E7.1 General (Cont'd)

E7.1.3 Service Configurations (Cont'd)

C. SMARTRing^{®/I} service (a.k.a. BellSouth Dedicated Ring) (Cont'd)

(C)

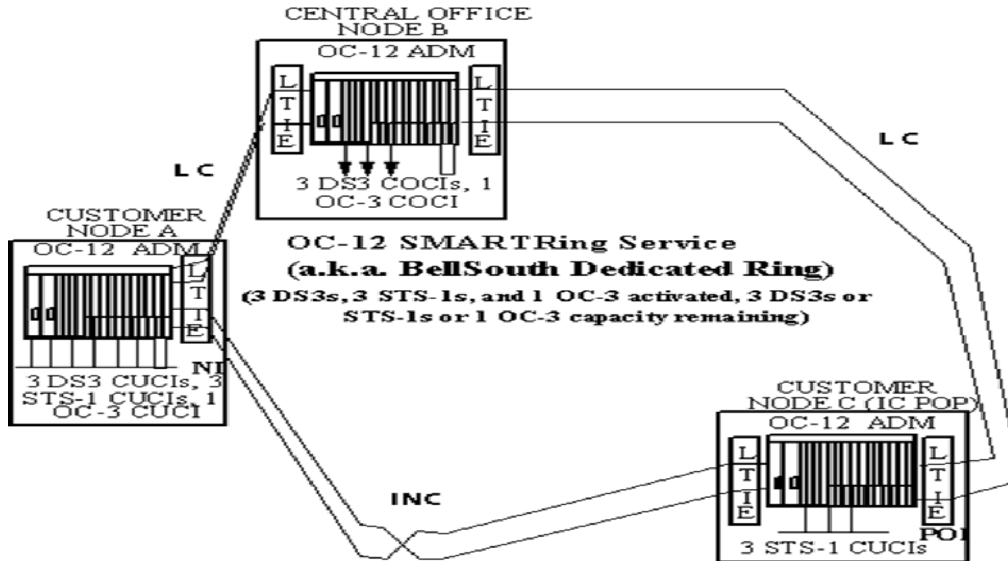

Example: SMARTRing[®] service (a.k.a. BellSouth Dedicated Ring) OC-12 capacity.

For this example the following rate elements are applicable:

(C)

- 2 Customer Nodes
- 1 Internodal Channel
- 6 STS-1 Customer Channel Interfaces
- 1 Central Office Nodes
- 3 DS3 Customer Channel Interfaces
- 1 OC-3 Customer Channel Interface
- 2 Local Channels
- 3 DS3 Central Office Channel Interfaces
- 1 OC-3 Central Office Channel Interface

Note 1: Effective on or after December 1, 2021, neither new nor existing customers will be permitted to purchase new SMARTRing Service (Service). In addition, (A) Service Payment Plans greater than 12-months in length will no longer be available; and (B) requests to move, add, change, upgrade, or downgrade existing service arrangements will not be accepted, with the following exceptions: (1) existing customers will be permitted to modify their existing Service and will be able to add new circuits to their existing Service, but will not be permitted to add new nodes in any locations; and (2) any such new circuits will be subject to the customer's existing term payment plan or term agreement for the Service to which they are added. Following the expiration of a customer's existing term agreement, Service will be provided on a month-to-month basis at the applicable Month-to-Month rates until the Service is discontinued.

(N)

Effective November 30, 2023, unless specified to the contrary in their existing Service agreements, existing customers may not renew Term Payment Plans or term agreements for Service. In addition, no move, add, or change orders of any type will be accepted.

(N)

**KENTUCKY
 PUBLIC SERVICE COMMISSION**

Linda C. Bridwell
 Executive Director



**EFFECTIVE
 12/1/2021**

PURSUANT TO 807 KAR 5:011 SECTION 9 (1)

E7. SPECIAL ACCESS (A.K.A. BELLSOUTH SPA) SERVICE

E7.1 General (Cont'd)

E7.1.3 Service Configurations (Cont'd)

C. SMARTRing[®] service (a.k.a. BellSouth Dedicated Ring) (Cont'd)

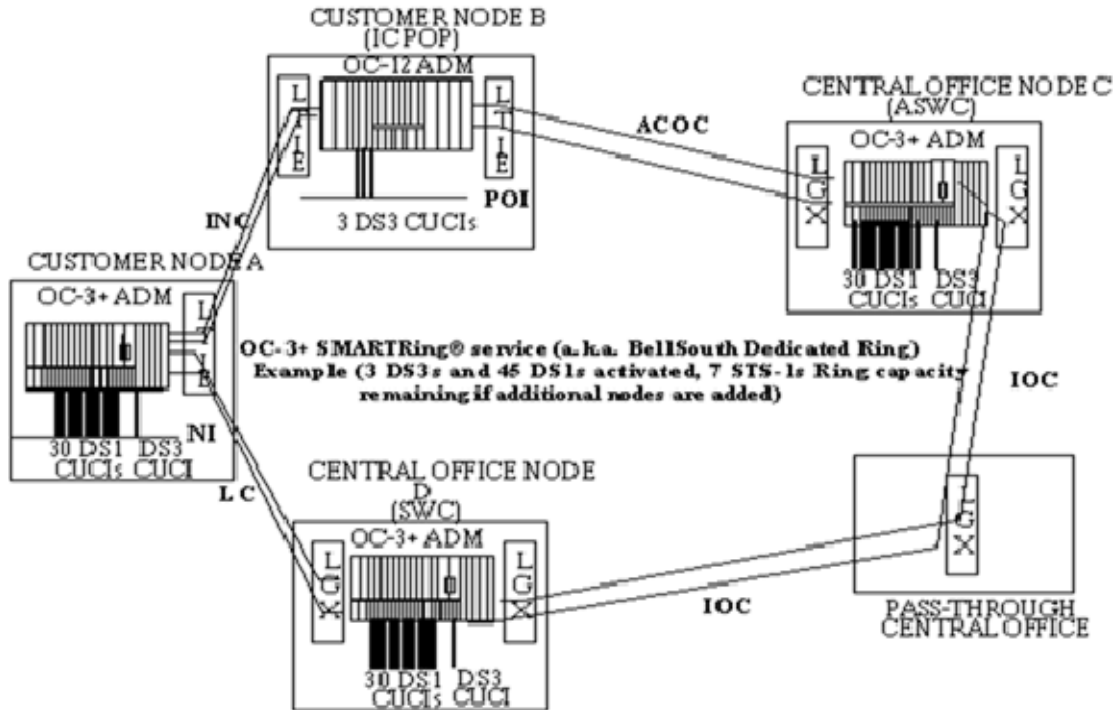

Example: SMARTRing[®] service (a.k.a. BellSouth Dedicated Ring) OC-3+ capacity.

For this example the following rate elements are applicable:

- 2 Customer Nodes
- 2 Central Office Nodes
- 1 Local Channel
- 1 Internodal Channel
- 1 Alternate Central Office Channel
- 2 Interoffice Channels
- 4 DS3 Customer Channel Interfaces
- 2 DS3 Central Office Channel Interfaces
- 30 DS1 Customer Channel Interfaces
- 60 DS1 Central Office Channel Interfaces

Note 1: Effective on or after December 1, 2021, neither new nor existing customers will be permitted to purchase new SMARTRing Service (Service). In addition, (A) Service Payment Plans greater than 12-months in length will no longer be available; and (B) requests to move, add, change, upgrade, or downgrade existing service arrangements will not be accepted, with the following exceptions: (1) existing customers will be permitted to modify their existing Service and will be able to add new circuits to their existing Service, but will not be permitted to add new nodes in any locations; and (2) any such new circuits will be subject to the customer's existing term payment plan or term agreement for the Service to which they are added. Following the expiration of a customer's existing term agreement, Service will be provided on a month-to-month basis at the applicable Month-to-Month rates until the Service is discontinued.

Effective November 30, 2023, unless specified to the contrary in their existing Service agreements, existing customers may not renew Term Payment Plans or term agreements for Service. In addition, no move, add, or change orders of any type will be accepted.

KENTUCKY
PUBLIC SERVICE COMMISSION

Linda C. Bridwell
Executive Director



EFFECTIVE
12/1/2021
PURSUANT TO 807 KAR 5:011 SECTION 9 (1)

E7. SPECIAL ACCESS (A.K.A. BELLSOUTH SPA) SERVICE

E7.1 General (Cont'd)

E7.1.3 Service Configurations (Cont'd)

C. SMARTRing^{®/I} service (a.k.a. BellSouth Dedicated Ring) (Cont'd)

(C)

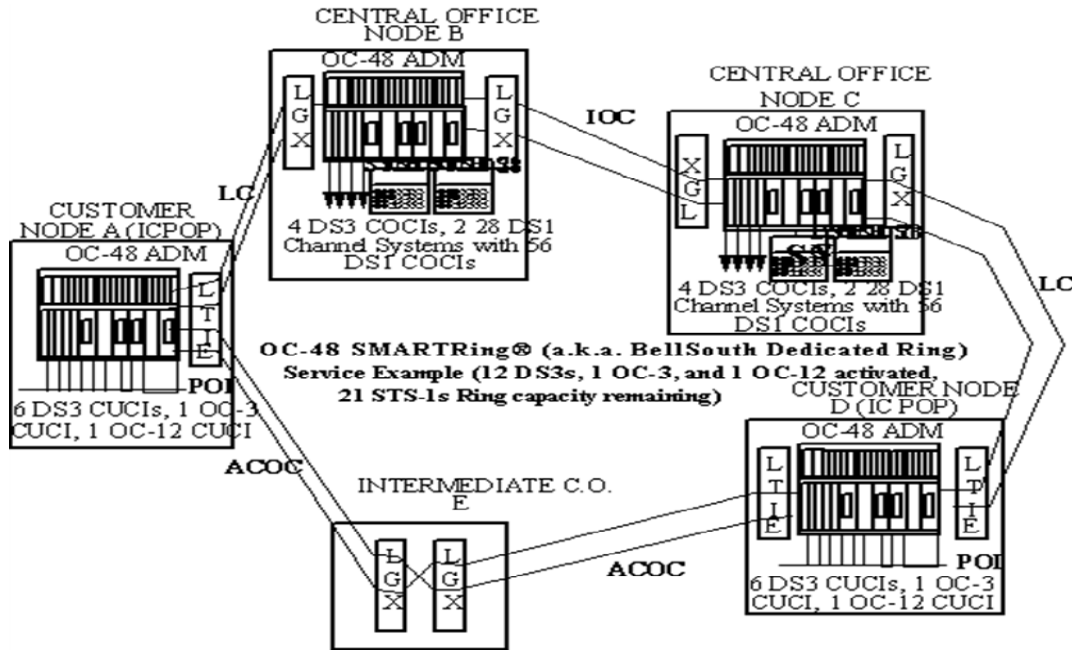

Example: SMARTRing[®] service (a.k.a. BellSouth Dedicated Ring) OC-48 capacity.

For this example the following rate elements are applicable:

(C)

- 2 Customer Nodes
- 2 Alternate Central Office Channels
- 112 DS1 Central Office Channel Interfaces
- 2 Central Office Nodes
- 12 DS3 Customer Channel Interfaces
- 2 OC-3 Customer Channel Interfaces
- 2 Local Channels
- 8 DS3 Central Office Channel Interfaces
- 2 OC-12 Customer Channel Interfaces
- 1 Interoffice Channel
- 4 28 DS1 Channel Systems (DS3)

Note 1: Effective on or after December 1, 2021, neither new nor existing customers will be permitted to purchase new SMARTRing Service (Service). In addition, (A) Service Payment Plans greater than 12-months in length will no longer be available; and (B) requests to move, add, change, upgrade, or downgrade existing service arrangements will not be accepted, with the following exceptions: (1) existing customers will be permitted to modify their existing Service and will be able to add new circuits to their existing Service, but will not be permitted to add new nodes in any locations; and (2) any such new circuits will be subject to the customer's existing term payment plan or term agreement for the Service to which they are added. Following the expiration of a customer's existing term agreement, Service will be provided on a month-to-month basis at the applicable Month-to-Month rates until the Service is discontinued.

(N)

Effective November 30, 2023, unless specified to the contrary in their existing Service agreements, existing customers may not renew Term Payment Plans or term agreements for Service. In addition, no move, add, or change orders of any type will be accepted.

(N)

**KENTUCKY
 PUBLIC SERVICE COMMISSION**

Linda C. Bridwell
 Executive Director



**EFFECTIVE
 12/1/2021**

PURSUANT TO 807 KAR 5:011 SECTION 9 (1)

E7. SPECIAL ACCESS (A.K.A. BELLSOUTH SPA) SERVICE

E7.1 General (Cont'd)

E7.1.3 Service Configurations (Cont'd)

C. SMARTRing^{®/I} service (a.k.a. BellSouth Dedicated Ring) (Cont'd)

(C)

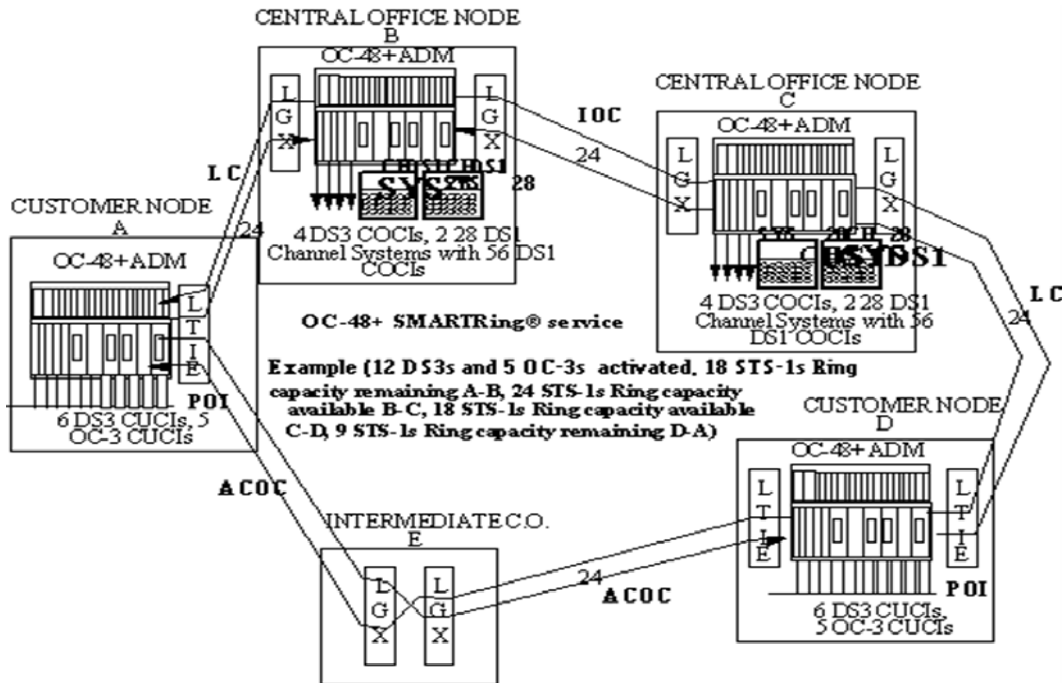

Example: SMARTRing[®] service (a.k.a. BellSouth Dedicated Ring) service OC-48+ capacity.

For this example the following rate elements are applicable:

(C)

- 2 Customer Nodes
- 2 Alternate Central Office Channels
- 4 28 DS1 Channel Systems (DS3)
- 2 Central Office Nodes
- 12 DS3 Customer Channel Interfaces
- 112 DS1 Central Office Channel Interfaces
- 2 Local Channels
- 8 DS3 Central Office Channel Interfaces
- 10 OC-3 Customer Channel Interfaces
- 1 Interoffice Channel

Note 1: Effective on or after December 1, 2021, neither new nor existing customers will be permitted to purchase new SMARTRing Service (Service). In addition, (A) Service Payment Plans greater than 12-months in length will no longer be available; and (B) requests to move, add, change, upgrade, or downgrade existing service arrangements will not be accepted, with the following exceptions: (1) existing customers will be permitted to modify their existing Service and will be able to add new circuits to their existing Service, but will not be permitted to add new nodes in any locations; and (2) any such new circuits will be subject to the customer's existing term payment plan or term agreement for the Service to which they are added. Following the expiration of a customer's existing term agreement, Service will be provided on a month-to-month basis at the applicable Month-to-Month rates until the Service is discontinued.

(N)

Effective November 30, 2023, unless specified to the contrary in their existing Service agreements, existing customers may not renew Term Payment Plans or term agreements for Service. In addition, no move, add, or change orders of any type will be accepted.

(N)

**KENTUCKY
 PUBLIC SERVICE COMMISSION**

Linda C. Bridwell
 Executive Director



**EFFECTIVE
 12/1/2021**

PURSUANT TO 807 KAR 5:011 SECTION 9 (1)

E7. SPECIAL ACCESS (A.K.A. BELLSOUTH SPA) SERVICE

E7.1 General (Cont'd)

E7.1.4 Alternate Use

Alternate Use occurs when a service is arranged by the Company so that the customer can select different types of transmission at different times. A customer may use a service in any privately beneficial manner. However, where technical or engineering changes are required to effectuate an alternative use, the Company will make such special arrangements available on an individual case basis.

The arrangement required to transfer the service from one operation to the other (i.e., the transfer relay and control leads) will be rated and provided on an individual case basis and filed in Section E12., Specialized Service or Arrangements. The customer will pay the stated tariff rates for the Access Service rate elements for the service ordered (i.e., Local Channels, Interoffice Channels as applicable, and Optional Features and Functions, if any.)

E7.1.5 Special Facilities Routing

A customer may request that the facilities used to provide Special Access (a.k.a. BellSouth SPA) service be specially routed. The regulations, rates and charges for Special Facilities Routing (i.e., Avoidance, Diversity and Cable Only) are as set forth in Section E11. following.

E7.1.6 Design Layout Report

At the request of the customer, the Company will provide to the customer the make-up of the facilities and services provided under this Tariff as Special Access (a.k.a. BellSouth SPA) service to aid the customer in designing its overall service. This information will be provided in the form of a Design Layout Report.

The Design Layout Report will be provided to the customer at no charge, and will be reissued or updated whenever these facilities are materially changed.

E7.1.7 Acceptance Testing

At no additional charge, the Company will, at the customer's request, cooperatively test, at the time of installation, the following parameters:

- A. For Voice Grade⁽²⁾ (a.k.a. BellSouth SPA DS0 VG) services, acceptance tests will include tests for loss, 3-tone slope, DC continuity, operational signaling, C-notched noise and C-message noise when these parameters are applicable and specified in the order for service. Additionally, for Voice Grade⁽²⁾ (a.k.a. BellSouth SPA DS0 VG) services, a balance (improved loss) test will be made if the customer has ordered the improved loss optional feature.
- B. For other analog services (i.e., Metallic⁽²⁾ (a.k.a. BellSouth SPA Metallic), Telegraph⁽²⁾ (a.k.a. BellSouth SPA Telegraph) and for digital services (i.e., Digital Data Access⁽²⁾ (a.k.a. BellSouth SPA DS0 Digital Data) and High Capacity (a.k.a. BellSouth SPA High Capacity)), acceptance tests will include tests for the parameters applicable to the service as specified in the order for service. (D)

In addition to the above tests, Additional Cooperative Acceptance Testing for Voice Grade⁽²⁾ (a.k.a. BellSouth SPA DS0 VG) service to test other parameters, as described in E13.3.5.B. following, is available at the customer's request. All test results will be made available to the customer upon request.

E7.1.8 Ordering Options And Conditions

- A. There are two ordering options available to the customer in the provision of Special Access (a.k.a. BellSouth SPA) service. These are:
 1. Access Order
- B. These options are set forth in detail in Section E5. preceding. Also included in that section are other charges which may be associated with ordering Special Access (a.k.a. BellSouth SPA) service (e.g., Service Date Change Charges, Cancellation Charges, etc.).

(1) (DELETED)

(2) Effective June 30, 2021, this Service will no longer be available for purchase by new or existing customers. In addition, requests to move, add, change, or renew existing service arrangements will not be accepted. Following the expiration of a customer's existing term agreement, service will be provided on a month-to-month basis. If a customer's service is discontinued, the Company currently plans to discontinue this service (T)

KENTUCKY
PUBLIC SERVICE COMMISSION

Linda C. Bridwell,
Executive Director

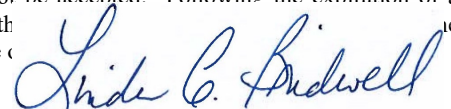

EFFECTIVE

1/1/2023

PURSUANT TO 807 KAR 5:011 SECTION 9 (1)

E7. SPECIAL ACCESS (A.K.A. BELLSOUTH SPA) SERVICE

E7.2 Service Descriptions

For the purposes of ordering, there are nine categories of Special Access (a.k.a. BellSouth SPA) service. These are:

- Metallic¹ (a.k.a. BellSouth SPA Metallic) (MT)
- Telegraph Grade¹ (a.k.a. BellSouth SPA Telegraph) (TG)
- Voice Grade¹ (a.k.a. BellSouth SPA DS0 VG) (VG)
- **(DELETED)**
- Digital Data Access¹ (a.k.a. BellSouth SPA DS0 Digital Data) Service (DDAS)
- High Capacity (a.k.a. BellSouth SPA High Capacity) (HC)
- WATS Access Line¹ (a.k.a. BellSouth SPA WATS Line) (WAL)
- Derived Data Channel¹ (a.k.a. BellSouth SPA Derived Data Channel) Service
- Self-Healing Rings (SMARTRing² service [a.k.a. BellSouth Dedicated Ring])

(T)

Note 1: Effective June 30, 2021, this Service will no longer be available for purchase by new or existing customers. In addition, requests to move, add, change, or renew existing service arrangements will not be accepted. Following the expiration of a customer's existing term agreement, service will be provided on a month-to-month basis at the applicable Monthly rates until the service is discontinued. The Company currently plans to discontinue this service on or after June 30, 2024.

Note 2: Effective on or after December 1, 2021, neither new nor existing customers will be permitted to purchase new SMARTRing Service (Service). In addition, (A) Service Payment Plans greater than 12-months in length will no longer be available; and (B) requests to move, add, change, upgrade, or downgrade existing service arrangements will not be accepted, with the following exceptions: (1) existing customers will be permitted to modify their existing Service and will be able to add new circuits to their existing Service, but will not be permitted to add new nodes in any locations; and (2) any such new circuits will be subject to the customer's existing term payment plan or term agreement for the Service to which they are added. Following the expiration of a customer's existing term agreement, Service will be provided on a month-to-month basis at the applicable Month-to-Month rates until the Service is discontinued.

Effective November 30, 2023, unless specified to the contrary in their existing Service agreements, existing customers may not renew Term Payment Plans or term agreements for Service. In addition, no move, add, or change orders of any type will be accepted.

**KENTUCKY
PUBLIC SERVICE COMMISSION**

Linda C. Bridwell
Executive Director



EFFECTIVE

1/1/2023

PURSUANT TO 807 KAR 5:011 SECTION 9 (1)

E7. SPECIAL ACCESS (A.K.A. BELLSOUTH SPA) SERVICE

E7.2 Service Descriptions (Cont'd)

Each service consists of a basic channel to which a predefined technical specifications package, channel interface(s) and, when desired, optional features and functions are added to construct the service desired by the customer. Each of the components of the service is described in this section. Terms and conditions for central office interconnection of collocator-provided transmission equipment are set forth in BellSouth Telecommunications, Inc., Tariff F.C.C. No. 1, Section 20. Terms, conditions, and rates for Physical Access Collocation Cross-Connects and Virtual Access Collocation Cross-Connects are set forth in Section E13. of this Tariff for those services that are permitted to connect directly to a carrier's collocation space. (M)

The channel description specifies the characteristics of the basic channel and indicates whether the channel is provided between customer designated premises or between a customer designated premises and a Company hub where bridging and/or channelization functions are performed. (M)

Information pertaining to the technical specifications packages indicates the transmission parameters that are available with each package. This information is displayed in a matrix with the transmission parameters listed down the left side and the packages listed across the top. Each package is identified by a code, e.g., VG1. The first two letters of the code indicate the category of Special Access (a.k.a. BellSouth SPA) service to which the parameters are applicable. These two-letter codes are shown above in parentheses following the category of Special Access (a.k.a. BellSouth SPA) service. The number "1" following the two-letter code indicates the technical specifications package for a voice grade¹ service. An alphanumeric designation following the two-letter code indicates the specific predefined package. When appropriate, the Technical Reference which contains detailed specifications for the parameters is shown following the matrix. (M)

Channel interfaces at each point of termination on a two-point service may be symmetrical or asymmetrical. On a multipoint service they may also be symmetrical or asymmetrical. However, communications can only be provided between points of termination with compatible channel interfaces. Only certain channel interfaces are compatible. These are set forth in a combination format. (M)

Only certain channel interface combinations are available with the predefined technical specifications packages. These are delineated in the Technical References set forth at the end of this E7.2. (M)

The optional features and functions available with each type of Special Access (a.k.a. BellSouth SPA) service are described in this section. The optional features and functions information also indicates with which technical specifications packages they are available. Such information is displayed in a matrix with the optional feature or function listed down the left side and the technical specifications package listed across the top. (M)

The Company will maintain existing transmission specifications on services installed prior to the effective date of this Tariff, except that the existing services with performance specifications exceeding the standard listed in this provision will be maintained at the performance levels specified in this Tariff. (M)

Note 1: Effective June 30, 2021, this Service will no longer be available for purchase by new or existing customers. In addition, requests to move, add, change, or renew existing service arrangements will not be accepted. Following the expiration of a customer's existing term agreement, service will be provided on a month-to-month basis at the applicable Monthly rates until the service is discontinued. The Company currently plans to discontinue this service on or after June 30, 2024. (M)



E7. SPECIAL ACCESS (A.K.A. BELLSOUTH SPA) SERVICE

E7.2 Service Descriptions (Cont'd)

All services installed after the effective date of this Tariff will conform to the transmission specification standards contained in this Tariff or in the following Technical References for each category of service:

Metallic ⁽²⁾ (a.k.a. BellSouth SPA Metallic)	TR-NPL-000336
Telegraph Grade ⁽²⁾ (a.k.a. BellSouth SPA Telegraph)	TR-NPL-000336
Voice Grade ⁽²⁾ (a.k.a. BellSouth SPA DSO VG)	TR-NPL-000335 PUB 41004, Table 4
(DELETED)	
(DELETED)	
Digital Data Access ⁽²⁾ (a.k.a. BellSouth SPA DSO Digital Data) For 2.4, 4.8, 9.6 and 56.0 Kbps For 19.2 Kbps	TR-NPL-000341 BellCore PUB 62310
For 64.0 Kbps High Capacity (a.k.a. BellSouth SPA High Capacity)	INC. BULLETIN CB-INC-100 AT&T PUB 62310 TA-TSY- 000342 TR-NPL-000054
WATS Access Line ⁽²⁾ (a.k.a. BellSouth SPA WATS Line) Derived Data Channel ⁽²⁾ (a.k.a. BellSouth SPA Derived Data Channel) service	TR-NPL-000334 BellSouth TR-73548 BellSouth TR-73548, Addendum 1

(T)

E7.2.1 Metallic⁽²⁾ (a.k.a. BellSouth SPA Metallic) Service

A. Basic Channel Description

A Metallic (a.k.a. BellSouth SPA Metallic) channel is an unconditioned two-wire channel capable of transmitting low speed varying signals at rates up to 30 baud. This channel is provided by metallic or equivalent facilities. Metallic (a.k.a. BellSouth SPA Metallic) channels are provided between customer designated premises or between a customer designated premises and a Company Hub where bridging functions are performed. Interoffice metallic facilities will be limited in length to a total of five miles per channel. Metallic (a.k.a. BellSouth SPA Metallic) facilities will only be provided where available.

B. Technical Specifications Packages

Parameter	Package MT-		
	1	2	3
DC Resistance Between Conductors	X	X	
Loop Resistance			X
Shunt Capacitance			X

The technical specifications are delineated in Technical Reference TR-NPL-000336.

C. Channel Interfaces

Compatible channel interfaces are set forth in Technical Reference TR-NPL-000336.

⁽¹⁾ **(DELETED)**

⁽²⁾ Effective June 30, 2021, this Service will no longer be available for purchase by new or existing customers. In addition, requests to move, add, change, or renew existing service arrangements will not be accepted. For term agreement, service will be provided on a month-to-month basis at the applicable rate. The Company currently plans to discontinue this service on or after June 30, 2024.

(T)

**KENTUCKY
PUBLIC SERVICE COMMISSION**

Linda C. Bridwell
Executive Director



**EFFECTIVE
1/1/2023**

PURSUANT TO 807 KAR 5:011 SECTION 9 (1)

E7. SPECIAL ACCESS (A.K.A. BELLSOUTH SPA) SERVICE

E7.2 Service Descriptions (Cont'd)

E7.2.1 Metallic¹ (a.k.a. BellSouth SPA Metallic) Service (Cont'd)

(C)

D. Optional Features and Functions

1. Central Office Bridging Capability

- a. Three Premises Bridging - Provision of tip-to-tip and ring-to-ring connection in a central office of a metallic pair to a third customer designated premises.
- b. Series Bridging of up to 26 customer designated premises.

The following table shows the technical specifications packages with which the optional features and functions are available.

	Available with Technical Specifications Package MT-		
	1	2	3
Three Premises Bridging	X		X
Series Bridging			X

E7.2.2 Telegraph¹ (a.k.a. BellSouth SPA Telegraph) Grade Service

(C)

A. Basic Channel Description

A Telegraph (a.k.a. BellSouth SPA Telegraph) Grade channel is an unconditioned channel capable of transmitting binary signals at rates of 0-75 baud or 0-150 baud. This channel is furnished for half-duplex or duplex operation. Telegraph (a.k.a. BellSouth SPA Telegraph) Grade channels are provided between customer designated premises or between a customer designated premises and a Company Hub. Telegraph (a.k.a. BellSouth SPA Telegraph) Grade service is not available for additions, new installations or moves of service.

B. Technical Specifications Packages

Parameter	Package TG-	
	1	2
Telegraph Distortion	X	X

The technical specifications are delineated in Technical Reference TR-NPL-000336.

C. Channel Interfaces

Compatible channel interfaces are set forth in Technical Reference TR-NPL-000336.

D. Optional Features and Functions

1. Telegraph Bridging (two-wire and four-wire)

The following table shows the technical specifications packages with which the optional features and functions are available.

	Available with Technical Specifications Package TG-	
	1	2
Telegraph Bridging	X	X

Note 1: Effective June 30, 2021, this Service will no longer be available for purchase by new or existing customers. In addition, requests to move, add, change, or renew existing service arrangements will not be accepted. Following the expiration of a customer's existing term agreement, service will be provided on a month-to-month basis at the applicable Monthly rates until the service is discontinued. The Company currently plans to discontinue this service on or after June 30, 2024.

(N)
 |
 (N)

KENTUCKY
 PUBLIC SERVICE COMMISSION

Linda C. Bridwell
 Executive Director

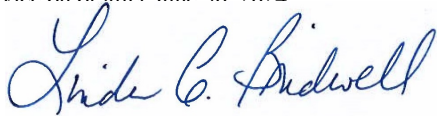

EFFECTIVE
 6/30/2021
 PURSUANT TO 807 KAR 5:011 SECTION 9 (1)

E7. SPECIAL ACCESS (A.K.A. BELLSOUTH SPA) SERVICE

E7.2 Service Descriptions (Cont'd)

E7.2.3 Voice Grade¹ (*a.k.a. BellSouth SPA DS0 VG*) Service

(C)

A. Basic Channel Description

A Voice Grade (*a.k.a. BellSouth SPA DS0 VG*) channel is a channel which provides voice frequency transmission capability in the nominal frequency range of 300 to 3000 Hz and may be terminated two-wire or four-wire. Voice Grade (*a.k.a. BellSouth SPA DS0 VG*) channels are provided between customer designated premises or between a customer designated premises and a Company Hub.

Voice Grade (*a.k.a. BellSouth SPA DS0 VG*) Channels are classified as Voice Grade/Voice or Voice Grade/Data depending on the suitability of the technical specification package requested by the customer. Voice Grade (*a.k.a. BellSouth SPA DS0 VG*) Technical Specification Packages 1, 2, 3, 4, 5, 7, 8, 9, 11 and 12 are suitable for Voice Grade/Voice. The Technical Specification Packages 6 and 10 are suitable for Voice Grade/Data Service.

Note 1: Effective June 30, 2021, this Service will no longer be available for purchase by new or existing customers. In addition, requests to move, add, change, or renew existing service arrangements will not be accepted. Following the expiration of a customer's existing term agreement, service will be provided on a month-to-month basis at the applicable Monthly rates until the service is discontinued. The Company currently plans to discontinue this service on or after June 30, 2024.

(N)
|
(N)

**KENTUCKY
PUBLIC SERVICE COMMISSION**

Linda C. Bridwell
Executive Director



EFFECTIVE

6/30/2021

PURSUANT TO 807 KAR 5:011 SECTION 9 (1)

E7. SPECIAL ACCESS (A.K.A. BELLSOUTH SPA) SERVICE

E7.2 Service Descriptions (Cont'd)

E7.2.3 Voice Grade¹ (a.k.a. BellSouth SPA DS0 VG) Service (Cont'd)

(C)

B. Technical Specifications Packages

Parameter	Package VG-											
	1	2	3	4	5	6	7	8	9	10	11	12
Attenuation Distortion	X	X	X	X	X	X	X	X	X	X	X	X
C-Message Noise	X	X	X	X	X	X	X	X	X	X	X	X
Echo Control	X	X	X		X		X	X			X	X
Envelope Delay												
Distortion						X	X	X	X	X	X	X
Frequency Shift						X	X	X	X	X	X	X
Impulse Noise					X	X	X	X	X	X	X	X
Intermodulation												
Distortion						X	X	X	X	X	X	X
Loss Deviation	X	X	X	X	X	X	X	X	X	X	X	X
Phase Jitter						X	X	X	X	X	X	X
Signal-to-C												
Message Noise				X								
Signal-to-C												
Notch Noise					X	X	X	X	X	X	X	X

The technical specifications for these parameters are delineated in Technical Reference TR-NPL-000335 and associated Addendum.

C. Channel Interfaces

The following channel interfaces for Voice Grade (a.k.a. BellSouth SPA DS0 VG) service do not require signaling capability: DA, DB, DD, DE, DS, NO, PR and TF.

The following channel interfaces for Voice Grade (a.k.a. BellSouth SPA DS0 VG) service require signaling capability: AB, AC, CT, DX, EA, EB, EC, EX, GO, GS, LA, LB, LC, LO, LR, LS, RV and SF.

Compatible channel interfaces are set forth in Technical Reference TR-NPL-A and Associated Addendum following.

Note 1: Effective June 30, 2021, this Service will no longer be available for purchase by new or existing customers. In addition, requests to move, add, change, or renew existing service arrangements will not be accepted. Following the expiration of a customer's existing term agreement, service will be provided on a month-to-month basis at the applicable Monthly rates until the service is discontinued. The Company currently plans to discontinue this service on or after June 30, 2024.

(N)
 |
 (N)

**KENTUCKY
 PUBLIC SERVICE COMMISSION**

Linda C. Bridwell
 Executive Director



**EFFECTIVE
 6/30/2021**

PURSUANT TO 807 KAR 5:011 SECTION 9 (1)

E7. SPECIAL ACCESS (A.K.A. BELLSOUTH SPA) SERVICE

E7.2 Service Descriptions (Cont'd)

E7.2.3 Voice Grade⁴ (a.k.a. BellSouth SPA DS0 VG) Service (Cont'd)

(C)

D. Optional Features and Functions

1. Central Office Bridging Capability
 - a. Voice Bridging¹ (two-wire and four-wire)
 - b. Data Bridging² (two-wire and four-wire)
 - c. Telephoto Bridging³ (two-wire and four-wire)

Note 1: Voice Bridging is intended for use with VG2, 5 and 12. However, it may be used on VG6 and VG10 at a customers request.

Note 2: Data Bridging is intended for use with VG6 and VG10. However, it may be used on VG2, 5 and 12 at a customers request.

Note 3: Telephoto Bridging is intended for use on VG11.

Note 4: Effective June 30, 2021, this Service will no longer be available for purchase by new or existing customers. In addition, requests to move, add, change, or renew existing service arrangements will not be accepted. Following the expiration of a customer's existing term agreement, service will be provided on a month-to-month basis at the applicable Monthly rates until the service is discontinued. The Company currently plans to discontinue this service on or after June 30, 2024.

(N)

(N)



E7. SPECIAL ACCESS A.K.A. BELLSOUTH SPA) SERVICE

E7.2 Service Descriptions (Cont'd)

E7.2.3 Voice Grade¹ (a.k.a. BellSouth SPA DS0 VG) Service (Cont'd)

D. Optional Features and Functions (Cont'd)

- d. Telemetry and Alarm Bridging
 - Split Band, Active Bridging

2. Conditioning

Conditioning provides more specific transmission characteristics for Voice Grade (a.k.a. BellSouth SPA DS0 VG) services. C-Type conditioning controls attenuation distortion and envelope delay distortion. Sealing Current helps maintain continuity on dry metallic¹ loops.

For two-point services, the parameters apply to each service. For multipoint services, the parameters apply to each mid link or end link. C-Type conditioning and D-Conditioning may be combined on the same service.

a. C-Type Conditioning

C-Type Conditioning is provided for the additional control of attenuation distortion and envelope delay distortion on data services. The attenuation distortion and envelope delay distortion specifications for C-Type Conditioning are:

Attenuation Distortion (Frequency Response) Relative to 1004 Hz

Frequency Range (Hz)	Variation (dB)
504 - 2804	-1.0 to + 3.0
304 - 3004	-2.0 to + 6.0

Envelope Delay Distortion

Frequency Range (Hz)	Variation (micro-seconds)
1004 - 2604	Less than 501
604 - 2604	Less than 1501
504 - 2804	Less than 3001

Note 1: Effective June 30, 2021, this Service will no longer be available for purchase by new or existing customers. In addition, requests to move, add, change, or renew existing service arrangements will not be accepted. Following the expiration of a customer's existing term agreement, service will be provided on a month-to-month basis at the applicable Monthly rates until the service is discontinued. The Company currently plans to discontinue this service on or after June 30, 2024.

(C)
 (C)
 (N)
 (N)

**KENTUCKY
 PUBLIC SERVICE COMMISSION**

Linda C. Bridwell
 Executive Director



**EFFECTIVE
 6/30/2021**

PURSUANT TO 807 KAR 5:011 SECTION 9 (1)

E7. SPECIAL ACCESS (A.K.A. BELLSOUTH SPA) SERVICE

E7.2 Service Descriptions (Cont'd)

E7.2.3 Voice Grade¹ (a.k.a. BellSouth SPA DS0 VG) Service (Cont'd)

(C)

D. Optional Features and Functions (Cont'd)

2. Conditioning (Cont'd)

b. Improved Attenuation Distortion

Improved attenuation distortion is provided for additional control of attenuation distortion. The improved attenuation distortion specifications are:

Attenuation Distortion (Frequency Response) Relative to 1004 Hz

Frequency Range (Hz)	Variation (dB)
404-2804	-1.0 to +2.0
304-3004	-1.0 to +3.0
3004-3204	-2.0 to +6.0

c. Improved Envelope Delay Distortion

Improved envelope delay distortion is provided for additional control of envelope distortion. The improved envelope delay distortion specifications are:

Envelope Delay Distortion

Frequency Range (Hz)	Variation (micro-seconds)
1001-2604	Less than 101
604-2604	Less than 301
504-2804	Less than 3001

d. Sealing Current Conditioning

Sealing Current Conditioning is provided to help maintain continuity on dry metallic¹ loops. It is usually associated with four-wire DA or NO type channel interfaces.

(C)

3. Customer Specified Premises Receive Level

This option allows the customer to specify the receive level at the Point of Termination for a two or four wire interface at the customer's premises. For a two wire interface the customer must order an effective four wire channel and must specify a receive level within the range allowable for effective four-wire transmission. For a four wire interface the receive level specified must be within the range allowable for four wire transmission. The customer can order improved termination for a wider range of receive levels. The ranges are delineated in Technical Reference TR-NPL-000335.

Note 1: Effective June 30, 2021, this Service will no longer be available for purchase by new or existing customers. In addition, requests to move, add, change, or renew existing service arrangements will not be accepted. Following the expiration of a customer's existing term agreement, service will be provided on a month-to-month basis at the applicable Monthly rates until the service is discontinued. The Company currently plans to discontinue this service on or after June 30, 2024.

(N)

(N)



E7. SPECIAL ACCESS (A.K.A. BELLSOUTH SPA) SERVICE

E7.2 Service Descriptions (Cont'd)

E7.2.3 Voice Grade¹ (a.k.a. BellSouth SPA DS0 VG) Service (Cont'd)

(C)

D. Optional Features and Functions (Cont'd)

4. Echo Control

a. ELEPL 2 (Equal Level Echo Path Loss)

On Effective Two-Wire Transmission at Four-Wire Point of Termination (applicable to each two-wire port): Provides for a fixed 600 ohm impedance, variable level range and simplex reversal. Company equipment is required at the customer's premises where this option is ordered. Improved Return Loss parameters are delineated in Technical Reference TR-NPL-000335.

b. Improved Return Loss

On Effective Two-Wire Transmission at Two-Wire Point of Termination: Provides for more stringent Echo Control specifications. In order for this option to be applicable, the transmission path must be four-wire at one Point of Termination (POT) and two-wire at the other POT. Placement of Company equipment may be required at the customer's premises with two-wire POT. The Improved Return Loss parameters are delineated in Technical Reference TR-NPL-000335.

5. D-Conditioning

D-Conditioning provides transmission characteristics suitable for data communications. Specifically, D-Conditioning provides for the control of Signal to C-Notched Noise Ratio and intermodulation distortion. It is available for two-point services or multipoint services.

The signal to C-Notched Noise Ratio and intermodulation distortion parameters for D-Conditioning are:

- Signal to C-Notched Noise Ratio is equal to or greater than 32dB

- Intermodulation distortion:

- Signal to second order modulation products (R2) is equal to or greater than 38dB

- Signal to third order modulation products (R3) is equal to or greater than 42dB

When a service equipped with D-Conditioning is used for voice communications, the quality of the voice transmission may not be satisfactory. D-Conditioning transmission characteristics are described in Technical Reference TR-NPL-000335 under the name Data Capability.

6. Telephoto Conditioning

Telephoto Conditioning provides transmission characteristics suitable for telephotographic communications. Specifically, Telephoto Conditioning is provided for the control of attenuation distortion and envelope delay distortion on telephotographic services. The attenuation distortion and envelope delay distortion parameters for Telephoto Conditioning are:

Note 1: Effective June 30, 2021, this Service will no longer be available for purchase by new or existing customers. In addition, requests to move, add, change, or renew existing service arrangements will not be accepted. Following the expiration of a customer's existing term agreement, service will be provided on a month-to-month basis at the applicable Monthly rates until the service is discontinued. The Company currently plans to discontinue this service on or after June 30, 2024.

(N)
|
(N)



E7. SPECIAL ACCESS (A.K.A. BELLSOUTH SPA) SERVICE

E7.2 Service Descriptions (Cont'd)

E7.2.3 Voice Grade¹ (a.k.a. BellSouth SPA DS0 VG) Service (Cont'd)

(C)

D. Optional Features and Functions (Cont'd)

6. Telephoto Conditioning (Cont'd)

**Attenuation Distortion
(1004 Hz Reference)**

Frequency Range (Hz)	Variation (dB)
500 - 3000	- 0.5 to + 1.5
300 - 3200	- 1.0 to + 2.5

Envelope Delay Distortion

Frequency Range (Hz)	Variation (mcs)
1000 - 2600	Less than 111
800 - 2800	Less than 181

7. Signaling Capability

Signaling Capability provides for the process by which one customer premises alerts another customer premises on the same service with which it wishes to communicate.

8. Improved Termination

The Improved Termination option provides a fixed 600 ohm impedance, a variable level range and simplex reversal, when applicable, at the point of termination. Company equipment is required at the customer's premises when this option is ordered. The Improved Termination parameters are delineated in Technical Reference TR-NPL-000335.

9. Simplex Reversal

The Simplex Reversal option physically turns over the simplex DC path presented at the four-wire point of termination when LO, LS, GO, GS, & DX signaling is provided at the point of termination.

10. FlexServ® service (a.k.a. BellSouth SPA Customer Reconfiguration)

FlexServ® service (a.k.a. BellSouth SPA Customer Reconfiguration) provides the customer the ability to monitor and reconfigure Voice Grade (a.k.a. BellSouth SPA DS0 VG) service provided by the Company. FlexServ® service (a.k.a. BellSouth SPA Customer Reconfiguration) is described in E7.4.12 following. Charges for this feature are contained in E7.5.16 following.

Note 1: Effective June 30, 2021, this Service will no longer be available for purchase by new or existing customers. In addition, requests to move, add, change, or renew existing service arrangements will not be accepted. Following the expiration of a customer's existing term agreement, service will be provided on a month-to-month basis at the applicable Monthly rates until the service is discontinued. The Company currently plans to discontinue this service on or after June 30, 2024.

(N)
|
(N)

**KENTUCKY
PUBLIC SERVICE COMMISSION**

Linda C. Bridwell
Executive Director



EFFECTIVE

6/30/2021

PURSUANT TO 807 KAR 5:011 SECTION 9 (1)

E7. SPECIAL ACCESS (A.K.A. BELLSOUTH SPA) SERVICE

E7.2 Service Descriptions (Cont'd)

E7.2.3 Voice Grade¹ (a.k.a. BellSouth SPA DS0 VG) Service (Cont'd)

(C)

D. Optional Features and Functions (Cont'd)

The following table shows the technical specifications packages with which the optional features and functions are available.

	Available with Technical Specifications Package VG-											
	1	2	3	4	5	6	7	8	9	10	11	12
C-Type Conditioning					X	X	X	X	X	X		
Improved Attenuation Distortion					X	X	X	X	X	X		
Improved Envelope Delay Distortion					X	X	X	X	X	X		
Central Office Bridging Capability		X			X	X				X	X	X
Customer Specified Premises Receive Level		X	X				X	X	X			
D-Conditioning						X	X		X			
Echo Control Improved Return Loss			X	X				X				
ELEPL2	X	X	X		X		X					
FlexServ [®] service (a.k.a. BellSouth SPA Customer Reconfiguration)	X	X	X	X	X	X	X	X	X	X	X	X
Improved Termination	X	X	X	X	X	X	X	X	X	X	X	X
Simplex Reversal	X	X	X				X	X	X			
Sealing Current Conditioning						X						
Signaling Capability	X	X	X				X	X	X			
Telephoto Conditioning											X	

Note 1: Effective June 30, 2021, this Service will no longer be available for purchase by new or existing customers. In addition, requests to move, add, change, or renew existing service arrangements will not be accepted. Following the expiration of a customer's existing term agreement, service will be provided on a month-to-month basis at the applicable Monthly rates until the service is discontinued. The Company currently plans to discontinue this service on or after June 30, 2024.

(N)
 |
 (N)

**KENTUCKY
 PUBLIC SERVICE COMMISSION**

Linda C. Bridwell
 Executive Director



**EFFECTIVE
 6/30/2021**

PURSUANT TO 807 KAR 5:011 SECTION 9 (1)

E7. SPECIAL ACCESS (A.K.A. BELLSOUTH SPA) SERVICE

E7.2 Service Descriptions (Cont'd)

E7.2.3 Voice Grade¹ (*a.k.a. BellSouth SPA DS0 VG*) Service (Cont'd)

E. Four-Wire/Two-Wire Conversions

When a customer requests that an effective four-wire channel be terminated with a two-wire channel interface at the customer designated premises, a four-wire to two-wire conversion is required. The rate for the conversion is included as part of the basic Local Channel rate.

F. WATS Access Line¹ (WAL) (*a.k.a. BellSouth SPA WATS Line*) service

1. Basic Channel Description

A WATS Access Line (*a.k.a. BellSouth SPA WATS Line*) service (WAL) provides a channel for voice frequency transmission capability. The service provides a connection between a customer designated premises and a WATS serving office associated with the closed end of *BellSouth SWA 8XX Toll Free Dialing Ten Digit Screening Service*, WATS (*a.k.a. BellSouth SPA WATS Line*) or similar services. It is provided for use with *BellSouth SWA FGD* in the originating and terminating direction and *BellSouth SWA FGA* and *BellSouth SWA FGB* in the terminating direction and *BellSouth SWA* arrangement features as set forth in Section E6. preceding. The Company is currently unable to provide originating WATS (*a.k.a. BellSouth SPA WATS Line*) service through *BellSouth SWA FGA* and *BellSouth SWA FGB*. Such service will be provided as specified in 2. and 3. following.

The following shall apply to the Company's provision of WATS Access Line (*a.k.a. BellSouth SPA WATS Line*) service:

- a. When the end user's serving wire center is not a WATS serving office, channel mileage charges will apply for a WATS access line (*a.k.a. BellSouth SPA WATS Line*) extension (WALE) between the end user's serving wire center and the nearest WATS serving office.
- b. When a customer, other than AT&T, orders originating WATS Access Line (*a.k.a. BellSouth SPA WATS Line*) service and the end user's serving wire center is a WATS serving office which is not equipped with equal access, the Company will provide the WAL service to the nearest equal access WATS serving office by use of a WALE and the channel mileage charges for the WALE will be waived.
- c. When a customer other than AT&T orders originating WATS Access Line (*a.k.a. BellSouth SPA WATS Line*) service and the end user's serving wire center is not a WATS serving office and the nearest WATS serving office is not equipped with equal access, channel mileage charges for a WALE to the nearest WATS serving office will apply, as indicated in 1. preceding, but the Company will provide an additional WALE to the nearest WATS serving office equipped with equal access and the channel mileage charge for the additional WALE will be waived.

WATS Access Line (*a.k.a. BellSouth SPA WATS Line*) service is arranged for either originating calling or terminating calling. It is provided with either rotary dial or dual tone multifrequency address signaling and either loop start, ground start, E & M or reverse battery supervisory signaling. The choice of the type of signaling is at the option of the customer and subject to the technical limitations identified in the Technical Reference TR-NPL-000334. WATS Access Line (*a.k.a. BellSouth SPA WATS Line*) service is provided as an effective two-wire, an effective four-wire or a DS1 (i.e., 1.544 Mbps) transmission path. The DS1 WAL is only available as a trunk side termination on suitably equipped electronic switch, e.g., 1/1A ESS with Digital Carrier Termination (DCT) or DMS-100 with a Line Trunk Unit (LTU).

Note 1: Effective June 30, 2021, this Service will no longer be available for purchase by new or existing customers. In addition, requests to move, add, change, or renew existing service arrangements will not be accepted. Following the expiration of a customer's existing term agreement, service will be provided on a month-to-month basis at the applicable Monthly rates until the service is discontinued. The Company currently plans to discontinue this service on or after June 30, 2024.

KENTUCKY
PUBLIC SERVICE COMMISSION

Linda C. Bridwell
Executive Director



EFFECTIVE
6/30/2021
PURSUANT TO 807 KAR 5:011 SECTION 9 (1)

(N)
|
(N)

E7. SPECIAL ACCESS (A.K.A. BELLSOUTH SPA) SERVICE

E7.2 Service Descriptions (Cont'd)

E7.2.3 Voice Grade¹ (a.k.a. BellSouth SPA DS0 VG) Service (Cont'd)

(C)

F. WATS Access Line¹ (WAL) (a.k.a. BellSouth SPA WATS Line) service (Cont'd)

(C)

2. Technical Specification Packages

Parameters	Package WAL -		
	1	2	3
Attenuation Distortion	X	X	
Bit error rate			X
C-Message Noise	X	X	
Echo Control	X	X	
Envelope Delay Distortion	X	X	
Frequency Shift	X	X	
Impulse Noise	X	X	
Intermodulation Distortion	X	X	
Loss Deviation	X	X	
Phase Jitter	X	X	
Signal-to-C Notch Noise	X	X	

The technical specifications are delineated in Technical Reference TR-NPL-000334.

3. The following interfaces are available with WAL Service:

LO, LS, DS, GO, GS, RV, EA, EB

Compatible channel interfaces are set forth in Technical Reference TR-NPL-000334.

4. Optional Features and Functions

- a. Two-wire and four-wire Central Office bridging capability.
- b. Improved two-wire voice transmission specifications.
- c. Certain other options associated with WAL services such as WATS Access Line (a.k.a. BellSouth SPA WATS Line) Nonchargeable Termination Options and Common Switching Optional Features are available as defined in Section E6. preceding.
- d. One-way.

Note 1: Effective June 30, 2021, this Service will no longer be available for purchase by new or existing customers. In addition, requests to move, add, change, or renew existing service arrangements will not be accepted. Following the expiration of a customer's existing term agreement, service will be provided on a month-to-month basis at the applicable Monthly rates until the service is discontinued. The Company currently plans to discontinue this service on or after June 30, 2024.

(N)

(N)

**KENTUCKY
 PUBLIC SERVICE COMMISSION**

Linda C. Bridwell
 Executive Director



**EFFECTIVE
 6/30/2021**

PURSUANT TO 807 KAR 5:011 SECTION 9 (1)

E7. SPECIAL ACCESS (A.K.A. BELLSOUTH SPA) SERVICE

E7.2 Service Descriptions (Cont'd)

E7.2.4 *Reserved For Future Use*

(T)

(D)



E7. SPECIAL ACCESS (A.K.A. BELLSOUTH SPA) SERVICE

E7.2 Service Descriptions (Cont'd)

E7.2.4 *Reserved For Future Use* (Cont'd)

(T)

(D)



BELLSOUTH
TELECOMMUNICATIONS, INC.
KENTUCKY

ACCESS SERVICES TARIFF

PSC KY. TARIFF 2E
Second Revised Page 17
Cancels First Revised Page 17
EFFECTIVE: February 16, 1997

ISSUED: January 17, 1997

BY: E.C. Roberts, Jr., President - KY
Louisville, Kentucky

E7. SPECIAL ACCESS (A.K.A. BELLSOUTH SPA) SERVICE

(T)

E7.2 Service Descriptions (Cont'd)

(T)

E7.2.5 Reserved For Future Use

PUBLIC SERVICE COMMISSION
OF KENTUCKY
EFFECTIVE

FEB 16 1997

PURSUANT TO 807 KAR 5.011,
SECTION 9 (1)

BY: Jordan C. Neal
FOR THE PUBLIC SERVICE COMMISSION

BELLSOUTH
TELECOMMUNICATIONS, INC.
KENTUCKY
ISSUED: January 17, 1997
BY: E.C. Roberts, Jr., President - KY
Louisville, Kentucky

ACCESS SERVICES TARIFF

PSC KY. TARIFF 2E
Second Revised Page 18
Cancels First Revised Page 18
EFFECTIVE: February 16, 1997

E7. SPECIAL ACCESS (A.K.A. BELLSOUTH SPA) SERVICE

(T)

E7.2 Service Descriptions (Cont'd)

(T)

E7.2.5 Reserved For Future Use

PUBLIC SERVICE COMMISSION
OF KENTUCKY
EFFECTIVE

FEB 16 1997

PURSUANT TO 807 KAR 5.011,
SECTION 9 (1)

BY: Jordan C. Neal
FOR THE PUBLIC SERVICE COMMISSION

E7. SPECIAL ACCESS (A.K.A. BELLSOUTH SPA) SERVICE

E7.2 Service Descriptions (Cont'd)

E7.2.6 Reserved For Future Use

E7.2.7 Digital Data Access² (a.k.a. BellSouth SPA DS0 Digital Data) Service

(C)

A. Basic Channel Description

A Digital Data (a.k.a. BellSouth SPA DS0 Digital Data) channel is a channel for duplex four-wire transmission of synchronous serial data at the rate of 2.4, 4.8, 9.6, 19.2, 56.0 or 64.0 Kbps. The actual bit rate is a function of the channel interface selected by the customer. The channel provides a synchronous service with timing provided by the Company through the Company's facilities to the customer in the received bit stream. Digital Data (a.k.a. BellSouth SPA DS0 Digital Data) channels are only available via Company designated Digital Data (a.k.a. BellSouth SPA DS0 Digital Data) Hubs and are provided between customer designated premises or between a customer designated premises and a Company Digital Data (a.k.a. BellSouth SPA DS0 Digital Data) Hub.

A Hub termination charge applies per Digital Local Channel. This rate element covers the Hub functions (e.g., timing, testing) for the service.

Secondary Channel Capability (SCC) is a derived companion digital transmission path that is independent of the primary data path and operates at a substantially lower bit rate. This derived channel allows the customer to perform network management functions during the normal operation of the network. This diagnostics channel utilizes a portion of a customer's previously unavailable data bit stream allowing for the ability to remotely control and test the network and peripheral devices without taking the network out of service. Special customer equipment is necessary to utilize the benefits of the Secondary Channel. Customers not wishing to utilize this capability will not be impacted. Due to transmission equipment restrictions, Secondary Channel cannot be provided on 56.0 Kbps circuits that require the installation of loop repeater equipment for provision of service. Secondary Channel Capability, also, cannot be provided on 64.0 Kbps circuits, since all of the available bit stream will be used by the customer.

The customer will provide the Channel Service Unit-type equipment or other Network Channel Terminating Equipment associated with the Digital Data (a.k.a. BellSouth SPA DS0 Digital Data) channel at the customer premises. The interim program for interconnection of such equipment is set forth in Technical Reference PUB AS No. 1.

B. Technical Specifications Packages

Parameter	Package DA-					
	1	2	3	4	5	6
Error-Free Seconds	X	X	X	X	X	X

The Company will provide a channel capable of meeting a monthly average performance equal to or greater than 99.875 percent error-free seconds¹ while the channel is in service, if it is measured through a CSU equivalent which is designed, manufactured, and maintained to conform with the specifications contained in Technical Reference PUB 62310.

Note 1: This channel performance does not apply when the Data Over Voice Channel option is used.

Note 2: Effective June 30, 2021, this Service will no longer be available for purchase by new or existing customers. In addition, requests to move, add, change, or renew existing service arrangements will not be accepted. Following the expiration of a customer's existing term agreement, service will be provided on a month-to-month basis at the applicable Monthly rates until the service is discontinued. The Company currently plans to discontinue this service on or after June 30, 2024.

(N)

(N)

**KENTUCKY
 PUBLIC SERVICE COMMISSION**

Linda C. Bridwell
 Executive Director



**EFFECTIVE
 6/30/2021**

PURSUANT TO 807 KAR 5:011 SECTION 9 (1)

E7. SPECIAL ACCESS (A.K.A. BELLSOUTH SPA) SERVICE

E7.2 Service Descriptions (Cont'd)

E7.2.7 Digital Data² (a.k.a. BellSouth SPA DS0 Digital Data) Service (Cont'd)

B. Technical Specifications Packages (Cont'd)

Interface options and service objectives for Digital Data Access (a.k.a. BellSouth SPA DS0 Digital Data) service are delineated in Technical Reference TR-NPL-000341.

C. Channel Interfaces

The following channel interfaces (CIs) define the bit rates that are available for a Digital Data (a.k.a. BellSouth SPA DS0 Digital Data) channel:

CI	Bit Rate
DU-24(S) ¹	2.4 Kbps
DU-48(S) ¹	4.8 Kbps
DU-96(S) ¹	9.6 Kbps
DU-19(S) ¹	19.2 Kbps

Note 1: (S) is an additional BellSouth designation for use when the optional Secondary Channel feature is required.

Note 2: Effective June 30, 2021, this Service will no longer be available for purchase by new or existing customers. In addition, requests to move, add, change, or renew existing service arrangements will not be accepted. Following the expiration of a customer's existing term agreement, service will be provided on a month-to-month basis at the applicable Monthly rates until the service is discontinued. The Company currently plans to discontinue this service on or after June 30, 2024.

(C)

(N)

(N)



E7. SPECIAL ACCESS (A.K.A. BELLSOUTH SPA) SERVICE

E7.2 Service Descriptions (Cont'd)

E7.2.7 Digital Data Access¹ (a.k.a. BellSouth SPA DS0 Digital Data) Service (Cont'd)

(C)

C. Channel Interfaces (Cont'd)

CI	Bit Rate
DU-56(S) ¹	56.0 Kbps
DU-64	64.0 Kbps

Compatible channel interfaces are set forth in Technical Reference TR-NPL-000-341.

D. Optional Features and Functions

1. Central Office Bridging Capability
2. Secondary Channel Capability
3. FlexServ[®] service (a.k.a. BellSouth SPA Customer Reconfiguration)

FlexServ[®] service (a.k.a. BellSouth SPA Customer Reconfiguration) provides the customer the ability to monitor and reconfigure Digital Data Access (a.k.a. BellSouth SPA DS0 Digital Data) service provided by the Company. FlexServ[®] service (a.k.a. BellSouth SPA Customer Reconfiguration) is described in E7.4.12 following. Charges for this feature are contained in E7.5.16 following.

4.

The following table shows the technical specifications packages with which the optional features and functions are available.

	Available with Technical Specifications Package DA-					
	1	2	3	4	5	6
Central Office Bridging Capability	X	X	X	X	X	
Secondary Channel Capability						
FlexServ [®] Service (a.k.a. BellSouth SPA Customer Reconfiguration)	X	X	X	X	X	X

Note 1: Effective June 30, 2021, this Service will no longer be available for purchase by new or existing customers. In addition, requests to move, add, change, or renew existing service arrangements will not be accepted. Following the expiration of a customer's existing term agreement, service will be provided on a month-to-month basis at the applicable Monthly rates until the service is discontinued. The Company currently plans to discontinue this service on or after June 30, 2024.

(N)
 |
 (N)

KENTUCKY
 PUBLIC SERVICE COMMISSION

Linda C. Bridwell
 Executive Director



EFFECTIVE
 6/30/2021
 PURSUANT TO 807 KAR 5:011 SECTION 9 (1)

E7. SPECIAL ACCESS (A.K.A. BELLSOUTH SPA) SERVICE

E7.2 Service Descriptions (Cont'd)

E7.2.8 High Capacity (a.k.a. BellSouth SPA High Capacity) Service

A. Basic Channel Description

A High Capacity (*a.k.a. BellSouth SPA High Capacity*) channel is a channel for the transmission of nominal 64.0 Kbps^{1,2} or 1.544, 3.152, 6.312, or 44.736 Mbps isochronous serial data. The actual bit rate is a function of the channel interface selected by the customer. High Capacity (*a.k.a. BellSouth SPA High Capacity*) channels are provided between customer designated premises or between a customer designated premises and a Company Hub. (C)

The customer will provide the Network Channel Terminating Equipment associated with the High Capacity (*a.k.a. BellSouth SPA High Capacity*) channel at the customer's premises. The interim program for interconnection of such equipment is set forth in Technical Reference PUB AS No. 1.

B. Technical Specifications Packages

Parameters	Package HC-				
	0	1	1C	2	3
Error-Free Seconds		X			

A channel with technical specifications package HC1 will be capable of an error-free second performance of 98.75 percent over a continuous 24 hour period as measured at the 1.544 Mbps rate through a CSU equivalent which is designed, manufactured, and maintained to conform with the specifications contained in Technical Reference TR-NPL-000054.

Note 1: Available only as a cross connect (through connection) of two 2.4, 4.8, 9.6, 19.2, 56.0 or 64.0 Kbps channels of two 1.544 Mbps facilities to a Digital Data (*a.k.a. BellSouth SPA DS0 Digital Data*) Hub(s). The customer must provide system and channel assignment data.

Note 2: Effective June 30, 2021, this Service will no longer be available for purchase by new or existing customers. In addition, requests to move, add, change, or renew existing service arrangements will not be accepted. Following the expiration of a customer's existing term agreement, service will be provided on a month-to-month basis at the applicable Monthly rates until the service is discontinued. The Company currently plans to discontinue this service on or after June 30, 2024. (N)

**KENTUCKY
 PUBLIC SERVICE COMMISSION**

Linda C. Bridwell
 Executive Director



**EFFECTIVE
 6/30/2021**
 PURSUANT TO 807 KAR 5:011 SECTION 9 (1)

E7. SPECIAL ACCESS (A.K.A. BELLSOUTH SPA) SERVICE

E7.2 Service Descriptions (Cont'd)

E7.2.8 High Capacity (a.k.a. BellSouth SPA High Capacity) Service (Cont'd)

C. Channel Interfaces

The following channel interfaces (CIs) define the bit rates that are available for a High Capacity (a.k.a. BellSouth SPA High Capacity) channel:

CI	Bit Rate
DS-15 ^{1,2}	1.544 Mbps (DS1)
DS-31	3.152 Mbps (DS1C)
DS-44	44.736 Mbps (DS3)
DS-63	6.312 Mbps (DS2)

(C)

Compatible channel interfaces are set forth in E7.3.1 following.

D. Optional Features and Functions

1.

2. Clear Channel Capability

- Clear Channel Capability (CCC) is an arrangement that alters a DS1/1.544 Mbps signal with unconstrained information bits, to meet pulse density requirements outlined in TR-NPL-000054 and TA-TSY-000342. This will allow a customer to transport an all zero octet over a DS1/1.544 Mbps High Capacity (a.k.a. BellSouth SPA DS1) channel, providing an available combined maximum 1.536 Mbps data rate. This arrangement requires the customer signal at the channel interface to conform to Bipolar with 8 Zero Substitution (B8ZS) line code as described in TR-NPL-000054 and TA-TSY-000342.
- CCC is provided on DS1/1.544 Mbps High Capacity (a.k.a. BellSouth SPA DS1) channels between two customer designated premises or between a customer-designated premises and a Company Hub location and is subject to the availability of facilities. This optional feature may be ordered at the same time the DS1/1.544 Mbps High Capacity (a.k.a. BellSouth SPA DS1) channel is ordered, or it may be ordered as an additional feature of an existing channel.
- When providing CCC via a DS3/44.736 Mbps High Capacity (a.k.a. BellSouth SPA DS3) channel, that DS3 channel must be designated, in Company records, as having Clear Channel Capability prior to the provisioning of a DS1/1.544 Mbps High Capacity (a.k.a. BellSouth SPA DS1) channel with CCC. Customers must agree to out-of-service periods required to add this feature to; 1) an existing DS1/1.544 Mbps High Capacity (a.k.a. BellSouth SPA DS1) channel or 2) a DS3/44.736 Mbps High Capacity (a.k.a. BellSouth SPA DS3) channel which transports a DS1/1.544 Mbps High Capacity (a.k.a. BellSouth SPA DS1) channel, to be optioned for B8ZS.

3. Transfer Arrangement

An arrangement that affords the customer an additional measure of flexibility in the use of their access channel(s). The arrangement can be utilized to transfer a leg of a Special Access (a.k.a. BellSouth SPA) service to either a spare or working channel that terminates in either the same or a different customer premises. A key activated or dial up control service is required to operate the transfer arrangement. A spare channel, if required, is not included as part of the option.

Note 1: A 64.0 kbps channel is available as a channel(s) of a 1.544 mbs facility to a Company Hub.

Note 2: Effective June 30, 2021, 64.0 kbps Service will no longer be available for purchase by new or existing customers. In addition, requests to move, add, change, or renew existing service arrangements will not be accepted. Following the expiration of a customer's existing term agreement, service will be provided on a month to month basis at the current rates until the service is discontinued. The service on or after June 30, 2024.

KENTUCKY
PUBLIC SERVICE COMMISSION

Linda C. Bridwell
Executive Director

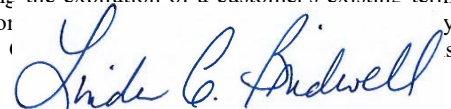

EFFECTIVE

6/30/2021

PURSUANT TO 807 KAR 5:011 SECTION 9 (1)

(N)

(N)

E7. SPECIAL ACCESS (A.K.A. BELLSOUTH SPA) SERVICE

E7.2 Service Descriptions (Cont'd)

E7.2.8 High Capacity (a.k.a. BellSouth SPA High Capacity) Service (Cont'd)

D. Optional Features and Functions (Cont'd)

4. Channelization

a. DS3 to DS1

An arrangement that channelizes a 44.736 Mbps channel to 28 DS1 channels.

b. DS2 to DS1

An arrangement that channelizes a 6.312 Mbps channel to four DS1 channels.

c. DS1C to DS1

An arrangement that channelizes a 3.152 Mbps channel to two DS1 channels.

d. DS1 Basic Channelization System

An arrangement that channelizes a 1.544 Mbps channel to a maximum of twenty-four 64.0 Kbps channels that may be used to activate both analog and digital services, e.g., voice grade, and digital data access service. A DS1 Basic Channelization System requires a Central Office Channel Interface for each channel of lesser capacity. (D)

e. DS0 Basic Channelization System⁽²⁾

An arrangement that channelizes a 64.0 Kbps channel to subspeeds of up to twenty 2.4 Kbps, ten 4.8 Kbps, or five 9.6 Kbps channels. A DS0 Basic Channelization System requires a Central Office Channel Interface for each channel of lesser capacity.

5. Channel Interface

a. DS1 Level Central Office Channel Interface

An arrangement for the connection of DS1 (1.544 Mbps) channels to higher order DS3 (44.736 Mbps) services in Company central office locations.

b. DS1 Level Customer Channel Interface

An arrangement for the connection of DS1 (1.544 Mbps) channels to higher order DS3 (44.736 Mbps) services at customer locations.

c. DS0 Level Central Office Channel Interface⁽²⁾

An arrangement for the connection of VG/DS0 (2.4-64.0 Kbps) channels to higher order DS1 (1.544 Mbps) services in Company central office locations.

d. Subrate Level Central Office Channel Interface⁽²⁾

An arrangement for the connection of subrate (2.4-9.6 Kbps) channels to higher order DS0 (64.0 Kbps) services in Company central office locations.

⁽¹⁾ (DELETED)

⁽²⁾ Effective June 30, 2021, this Service will no longer be available for purchase by new or existing customers. In addition, requests to move, add, change, or renew existing service arrangements will not be accepted. Following the expiration of a customer's existing term agreement, service will be provided on a month-to-month basis at the applicable Monthly rates until the service is discontinued his service on or after June 30, 2024.



(T)

E7. SPECIAL ACCESS (A.K.A. BELLSOUTH SPA) SERVICE

E7.2 Service Descriptions (Cont'd)

E7.2.8 High Capacity (a.k.a. BellSouth SPA High Capacity) Service (Cont'd)

D. Optional Features and Functions (Cont'd)

6. FlexServ® service (a.k.a. BellSouth SPA Customer Reconfiguration)

FlexServ® service provides the customer the ability to monitor and reconfigure High Capacity (a.k.a. BellSouth SPA High Capacity) service provided by the Company. FlexServ® service (a.k.a. BellSouth SPA Customer Reconfiguration) is described in E7.4.12. Charges for this feature are contained in E7.5.16.

The following table shows the technical specifications packages with which the optional features and functions are available.

**Available With Technical Specifications Package HC-
 0 1 1C 2 3**

Channelization:					
DS3 to DS1					X
DS2 to DS1				X	
DS1C to DS1			X		
DS1 Basic Channelization System		X			
DS0 Basic Channelization System ^{1,2}	X				
Transfer Arrangement		X			
Clear Channel Capability		X			
FlexServ® Service (a.k.a. BellSouth SPA Customer Reconfiguration)	X	X			

E7.2.9 Reserved for Future Use

E7.2.10 Reserved for Future Use

E7.2.11 Reserved for Future Use

E7.2.12 Reserved for Future Use

E7.2.13 Reserved for Future Use

Note 1: Available only on 64.0 Kbps DDAS (a.k.a. BellSouth SPA DS0 Digital Data) service or on a DS1 (1.544 Mbps) channel with Clear Channel Capability to a Company hub.

Note 2: Effective June 30, 2021, this Service will no longer be available for purchase by new or existing customers. In addition, requests to move, add, change, or renew existing service arrangements will not be accepted. Following the expiration of a customer's existing term agreement, service will be provided on a month-to-month basis at the applicable Monthly rates until the service is discontinued. The Company currently plans to discontinue this service on or after June 30, 2024.

(N)
 |
 (N)

KENTUCKY
PUBLIC SERVICE COMMISSION

Linda C. Bridwell
 Executive Director



EFFECTIVE
6/30/2021
 PURSUANT TO 807 KAR 5:011 SECTION 9 (1)

®Registered Service Mark of BellSouth Corporation
 * Service Mark of BellSouth Corporation

BELLSOUTH
TELECOMMUNICATIONS, INC.
KENTUCKY
ISSUED: November 30, 2001
BY: E.C. Roberts, Jr., President - KY
Louisville, Kentucky

ACCESS SERVICES TARIFF

PSC KY. TARIFF 2E
Fifth Revised Page 22.1
Cancels Fourth Revised Page 22.1
EFFECTIVE: December 30, 2001

E7. SPECIAL ACCESS (A.K.A. BELLSOUTH SPA) SERVICE

E7.2 Service Descriptions (Cont'd)

E7.2.14 (DELETED)

(D)

PUBLIC SERVICE COMMISSION
OF KENTUCKY
EFFECTIVE

DEC 30 2001

PURSUANT TO 807 KAR 5.011,
SECTION 9 (1)

BY: Stephan D. Bell
SECRETARY OF THE COMMISSION

E7. SPECIAL ACCESS (A.K.A. BELLSOUTH SPA) SERVICE

E7.2 Service Descriptions (Cont'd)

E7.2.14 (DELETED) (Cont'd)

E7.2.15 Derived Data Channel¹ (a.k.a. BellSouth SPA Derived Data Channel) Service

(C)

A. Basic Service Description

Derived Data Channel (a.k.a. BellSouth SPA Derived Data Channel) service (DDCS) provides full-duplex asynchronous or synchronous data transmission utilizing data over voice and subrate multiplexing technology. DDCS (a.k.a. BellSouth SPA Derived Data Channel) provides simultaneous data and voice transmissions over the customer's existing two-wire local exchange facility. A derived data channel is provided between the customer's premises and the customer's serving wire center.

At the customer's serving wire center the data/voice terminating equipment provides subrate multiplexing into a standard DS0-B interface for a group composed of a maximum of twenty derived data channels. The customer's derived data channel must be associated with a DS0-B interface. This association requires coordination between the subscriber of the derived data channel and the subscriber of the DS0-B interface. An interoffice channel is provided for interconnection of the subrate multiplexed DS0-B interface to the serving wire center of a customer designated premises.

DDCS (a.k.a. BellSouth SPA Derived Data Channel) is provided subject to the availability of appropriate network facilities and equipment and subject to the transmission limitations of the facilities and equipment used by the Company.

The customer will be responsible for selecting his own Customer Premises Equipment (CPE). CPE must be compatible with the Company provided terminating equipment at the serving wire center.

Note 1: Effective June 30, 2021, this Service will no longer be available for purchase by new or existing customers. In addition, requests to move, add, change, or renew existing service arrangements will not be accepted. Following the expiration of a customer's existing term agreement, service will be provided on a month-to-month basis at the applicable Monthly rates until the service is discontinued. The Company currently plans to discontinue this service on or after June 30, 2024.

(N)
|
(N)

**KENTUCKY
PUBLIC SERVICE COMMISSION**

Linda C. Bridwell
Executive Director



EFFECTIVE

6/30/2021

PURSUANT TO 807 KAR 5:011 SECTION 9 (1)

E7. SPECIAL ACCESS (A.K.A. BELLSOUTH SPA) SERVICE

E7.2 Service Descriptions (Cont'd)

E7.2.15 Derived Data Channel¹ (a.k.a. BellSouth SPA Derived Data Channel) Service (Cont'd)

B. Channel Interfaces

The following channel interface (CI) is available for DDCS (a.k.a. BellSouth SPA Derived Data Channel).

CI

2DV5.BA

Bit Rate

2.4 Kbps, Digital Data Over Voice¹

Compatible channel interface specifications are contained in BellSouth Technical Reference Publication 73548 for data/voice multiplexing equipment and BellSouth Technical Reference 73548, Addendum 1, for the DS0-B interface. These publications are available from the Information Exchange Manager, BellSouth Telecommunications, Inc., Documentations Operations, North W5A1, 3535 Colonnade Parkway, Birmingham, Alabama 35243.

Note 1: Effective June 30, 2021, this Service will no longer be available for purchase by new or existing customers. In addition, requests to move, add, change, or renew existing service arrangements will not be accepted. Following the expiration of a customer's existing term agreement, service will be provided on a month-to-month basis at the applicable Monthly rates until the service is discontinued. The Company currently plans to discontinue this service on or after June 30, 2024.



E7. SPECIAL ACCESS (A.K.A. BELLSOUTH SPA) SERVICE

E7.2 Service Descriptions (Cont'd)

E7.2.16 SMARTRing^{®2} Service (a.k.a. BellSouth Dedicated Ring)

A. Self-healing Multi-nodal Alternate Route Topology Ring

1. SMARTRing[®] service (a.k.a. BellSouth Dedicated Ring) is a dedicated, high capacity, network designed to provide increased reliability and functionality via a self-healing ring topology between multiple customer designated locations and Company Central Offices where facilities can be made available as determined by the Company. This network consists of fiber routed through local, alternate central office, intermodal and/or interoffice channel facilities that transmit DS1, DS3, STS-1, OC-3, OC-12, OC-48 and/or 1000 Mbps channel services simultaneously over primary and alternate paths between customer designated locations and Company Central Offices. This ring topology will continually monitor DS1, DS3, STS-1, OC-3, OC-12, OC-48 and/or 1000 Mbps service quality, detect any failure within the system, and automatically self-heal around a point of failure to ensure the flow of DS1, DS3, STS-1, OC-3, OC-12, OC-48 and/or 1000 Mbps services between locations within the network.
2. SMARTRing[®] service (a.k.a. BellSouth Dedicated Ring) is available at OC-1, OC-3, OC-3+ OC-12, OC-48, OC-48+, OC-192 and OC-192+ capacities.
3. OC-1 SMARTRing[®] service (a.k.a. BellSouth Dedicated Ring) is available only in Overlay Ring Arrangements riding the customer's host OC-12, OC-48, or OC-48+ SMARTRing[®] service (a.k.a. BellSouth Dedicated Ring). The OC-1 SMARTRing[®] service (a.k.a. BellSouth Dedicated Ring) shares the transport of its host SMARTRing[®] service (a.k.a. BellSouth Dedicated Ring). OC-1 SMARTRing[®] service (a.k.a. BellSouth Dedicated Ring) provides an equivalent capacity of 28 DS1s or one STS-1. When an OC-1 SMARTRing[®] service (a.k.a. BellSouth Dedicated Ring) overlays an OC-12, OC-48, or OC-48+ SMARTRing[®] service (a.k.a. BellSouth Dedicated Ring), an OC-1 channel interface is required.
4. OC-3 SMARTRing[®] service (a.k.a. BellSouth Dedicated Ring) is available as an individual service or in an Overlay Ring Arrangement riding the customer's host OC-12, OC-48, OC-48+, OC-192 or OC-192+ SMARTRing[®] service (a.k.a. BellSouth Dedicated Ring). OC-3 SMARTRing[®] service (a.k.a. BellSouth Dedicated Ring) provides an equivalent capacity of 3 DS3s, or any combination thereof not to exceed an OC-3 capacity. Channel Interface Reallocation allows the customer to reallocate STS-1, DS3 and/or DS1 capacities to OC-3 nodes subsequent to the initial configuration of an OC-3 ring.
5. OC-3+ SMARTRing^{®(1)} service (a.k.a. BellSouth Dedicated Ring) is available as an individual service, or in combination with OC-12 SMARTRing[®] service (a.k.a. BellSouth Dedicated Ring), or in an Overlay Ring Arrangement riding the customer's host OC-48, OC-48+, OC-192 or OC-192+ SMARTRing[®] service (a.k.a. BellSouth Dedicated Ring). OC-3+ SMARTRing[®] service (a.k.a. BellSouth Dedicated Ring) provides an equivalent OC-3 capacity, not to exceed 3 DS3s at each node, with a maximum ring capacity of 12 DS3s, not to exceed an OC-12 ring capacity.

Note 1: Effective July 4, 2015, the Company will accept only disconnect orders for OC-3+ SMARTRing service (a.k.a. BellSouth SPA Dedicated Ring), including orders associated with existing service. Move, add or change orders will no longer be accepted.

Note 2: Effective on or after December 1, 2021, neither new nor existing customers will be permitted to purchase new SMARTRing Service (Service). In addition, (A) Service Payment Plans greater than 12-months in length will no longer be available; and (B) requests to move, add, change, upgrade, or downgrade existing service arrangements will not be accepted, with the following exceptions: (1) existing customers will be permitted to modify their existing Service and will be able to add new circuits to their existing Service, but will not be permitted to add new nodes in any locations; and (2) any such new circuits will be subject to the customer's existing term payment plan or term agreement for the Service to which they are added. Following the expiration of a customer's existing term agreement, Service will be provided on a month-to-month basis at the applicable Month-to-Month rates until the Service is discontinued.

Effective November 30, 2023, unless specified to the contrary in their existing Service agreements, existing customers may not renew Term Payment Plans or term agreements for Service. In addition, no move, add, or change orders of any type will be accepted.

Material previously appearing on this page now appears on page(s) 22.4.1 of this section.

All BellSouth marks contained herein are owned by BellSouth Intellectual Property Corporation

**KENTUCKY
PUBLIC SERVICE COMMISSION**

Linda C. Bridwell
Executive Director



EFFECTIVE

12/1/2021

PURSUANT TO 807 KAR 5:011 SECTION 9 (1)

E7. SPECIAL ACCESS (A.K.A. BELLSOUTH SPA) SERVICE

E7.2 Service Descriptions (Cont'd)

E7.2.16 SMARTRing¹ Service (a.k.a. BellSouth Dedicated Ring) (Cont'd)

- A. Self-healing Multi-nodal Alternate Route Topology Ring (Cont'd)
6. When a customer orders OC-3+ SMARTRing[®] service (a.k.a. BellSouth Dedicated Ring) in combination with OC-12 SMARTRing[®] service (a.k.a. BellSouth Dedicated Ring), capacity and channel interface availability at each Customer Node and Central Office Node location is determined by the size node ordered by the customer. (M1)
 7. OC-12 SMARTRing[®] service (a.k.a. BellSouth Dedicated Ring) is available as an individual service, or in combination with OC-3+ SMARTRing[®] service (a.k.a. BellSouth Dedicated Ring), or in an Overlay Ring Arrangement riding the customer's host OC-48, OC-48+, OC-192 or OC-192+ SMARTRing[®] service (a.k.a. BellSouth Dedicated Ring). OC-12 SMARTRing[®] service (a.k.a. BellSouth Dedicated Ring) provides an equivalent capacity of 12 DS3s. (M1)
 8. OC-48 SMARTRing[®] service (a.k.a. BellSouth Dedicated Ring) is available as an individual service, or in an Overlay Ring Arrangement riding the customer's host OC-192 or OC-192+ SMARTRing[®] service (a.k.a. BellSouth Dedicated Ring), or with overlaying rings in capacities of OC-1, OC-3, OC-3+ and/or OC-12. OC-48 SMARTRing[®] service (a.k.a. BellSouth Dedicated Ring) provides an equivalent capacity of 48 DS3s. (M1)
 9. OC-48+ SMARTRing[®] service (a.k.a. BellSouth Dedicated Ring) is available as an individual bi-directional service, or in an Overlay Ring Arrangement riding the customer's host OC-192 SMARTRing[®] service (a.k.a. BellSouth Dedicated Ring), or with overlaying rings in capacities of OC-1, OC-3, OC-3+ or OC-12. It provides equivalent capacity of 24 DS3s between consecutive node locations on the ring. The maximum capacity of the OC-48+ SMARTRing[®] service (a.k.a. BellSouth Dedicated Ring) is determined by the number of Customer and Central Office nodes on the ring. (M1)
 10. OC-192 SMARTRing[®] service (a.k.a. BellSouth Dedicated Ring) is available as an individual service, or with overlaying rings in capacities of OC-3, OC-3+, OC-12, OC-48 and /or OC-48+. OC-192 SMARTRing[®] service (a.k.a. BellSouth Dedicated Ring) provides an equivalent capacity of 192 DS3s. (M1)
 11. OC-192+ SMARTRing[®] service (a.k.a. BellSouth Dedicated Ring) is available as an individual bi-directional service, or with overlaying rings in capacities of OC-3, OC-3+, OC-12 and /or OC-48. It provides equivalent capacity of 96 DS3s between consecutive node locations on the ring. The maximum capacity of the OC-192+ SMARTRing[®] service (a.k.a. BellSouth Dedicated Ring) is determined by the number of Customer and Central Office nodes on the ring. (M2)
- Note 1:** Effective on or after December 1, 2021, neither new nor existing customers will be permitted to purchase new SMARTRing Service (Service). In addition, (A) Service Payment Plans greater than 12-months in length will no longer be available; and (B) requests to move, add, change, upgrade, or downgrade existing service arrangements will not be accepted, with the following exceptions: (1) existing customers will be permitted to modify their existing Service and will be able to add new circuits to their existing Service, but will not be permitted to add new nodes in any locations; and (2) any such new circuits will be subject to the customer's existing term payment plan or term agreement for the Service to which they are added. Following the expiration of a customer's existing term agreement, Service will be provided on a month-to-month basis at the applicable Month-to-Month rates until the Service is discontinued. Effective November 30, 2023, unless specified to the contrary in their existing Service agreements, existing customers may not renew Term Payment Plans or term agreements for Service. In addition, no move, add, or change orders of any type will be accepted. (N)

KENTUCKY
PUBLIC SERVICE COMMISSION

Linda C. Bridwell
Executive Director



EFFECTIVE

12/1/2021

PURSUANT TO 807 KAR 5:011 SECTION 9 (1)

M1 Material appearing on this page previously appeared on page(s) 22.4 of this section.

M2 Material previously appearing on this page now appears on page(s) 22.4.2 through 22.4.4 of this section.

E7. SPECIAL ACCESS (A.K.A. BELLSOUTH SPA) SERVICE

E7.2 Service Descriptions (Cont'd)

E7.2.16 SMARTRing⁷ Service (a.k.a. BellSouth Dedicated Ring) (Cont'd)

A. Self-healing Multi-nodal Alternate Route Topology Ring (Cont'd)

12. SMARTRing service (a.k.a. BellSouth Dedicated Ring) Channel Interfaces are available as follows:

<u>Channel Interfaces</u>	<u>Nodes</u>								
	<u>OC-1</u>	<u>OC-3</u>	<u>OC-3+</u>	<u>OC-12</u>	<u>OC-48</u>	<u>OC-48+</u>	<u>OC-192</u>	<u>OC-192+</u>	
DS1	Yes	Yes	Yes	No ¹	No ¹	No ¹	No ¹	No ¹	
DS3	No	Yes	Yes	Yes	Yes	Yes	Yes	Yes	
STS-1	Yes	Yes	Yes	Yes	Yes	Yes	Yes	Yes	
OC-1 ²	No	No	No	Yes	Yes	Yes	No	No	
OC-3	No	No	No	Yes	Yes	Yes	Yes	Yes	
OC-12	No	No	No	No	Yes	Yes	Yes	Yes	
28 DS1 Channel System (DS3)	No	Yes	Yes	Yes	Yes	Yes	Yes	Yes	
28 DS1 Channel System (STS-1)	No	Yes	Yes	Yes	Yes	Yes	Yes	Yes	
1000 Mbps	No	No	No	No	Yes ³	Yes ³	Yes	Yes	
100 Mbps BellSouth Metro Ethernet ⁶ Backbone ⁴	No	No	No	Yes	Yes	Yes	Yes	Yes	
1000 Mbps BellSouth Metro Ethernet ⁶ Backbone	No	No	No	No	Yes	Yes	Yes	Yes	
Fractional 1000 Mbps at 150 Mbps, 300 Mbps or 450 Mbps BellSouth Metro Ethernet ⁶ Backbone ⁵	No	Yes	Yes	Yes	Yes	Yes	Yes	Yes	
Fractional 1000 Mbps at 600 Mbps BellSouth Metro Ethernet ⁶ Backbone ⁵	No	No	No	No	Yes	Yes	Yes	Yes	

Note 1: DS1 interfaces are available via OC-1, OC-3, and OC-3+ Overlay Ring Arrangements or 28 DS1 Channel Systems only. (M)

Note 2: OC-1 interfaces are only available for use with OC-1 Overlay Ring Arrangements. (M)

Note 3: 1000 Mbps interfaces are only available for rings installed after November 28, 2003. 1000 Mbps transport channel interfaces do not contain any monitoring capability above the physical layer. (M)

Note 4: 100 Mbps BellSouth Metro Ethernet Backbone interfaces are further defined regarding the number of STS-1s utilized in conjunction with the interface. (M)

Note 5: Interface availability is based on equipment capability. (M)

Note 6: Effective on or after August 22, 2021, this Service will no longer be available for purchase by new or existing customers. In addition, requests to move, add, change, or renew existing service arrangements will not be accepted. Following the expiration of a customer's existing term agreement, service will be provided on a month-to-month basis at the applicable Monthly rates until the service is discontinued. The Company currently plans to discontinue this service on or after March 31, 2023. (M)

Note 7: Effective on or after December 1, 2021, neither new nor existing customers will be permitted to purchase new SMARTRing Service (Service). In addition, (A) Service Payment Plans greater than 12-months in length will no longer be available; and (B) requests to move, add, change, upgrade, or downgrade existing service arrangements will not be accepted, with the following exceptions: (1) existing customers will be permitted to modify their existing Service and will be able to add new circuits to their existing Service, but will not be permitted to add new nodes in any locations; and (2) any such new circuits will be subject to the customer's existing term payment plan or term agreement for the Service to which they are added. Following the expiration of a customer's existing term agreement, Service will be provided on a month-to-month basis at the applicable Month-to-Month rates until the Service is discontinued. (N)

Effective November 30, 2023, unless specified to the contrary in their existing Service agreements, existing customers may not renew Term Payment Plans or term agreements for Service. In addition, no move, add, or change orders of any type will be accepted. (N)

**KENTUCKY
PUBLIC SERVICE COMMISSION**

Linda C. Bridwell
Executive Director



**EFFECTIVE
12/1/2021**

PURSUANT TO 807 KAR 5:011 SECTION 9 (1)

E7. SPECIAL ACCESS (A.K.A. BELLSOUTH SPA) SERVICE

E7.2 Service Descriptions (Cont'd)

E7.2.16 SMARTRing¹ Service (a.k.a. BellSouth Dedicated Ring) (Cont'd)

A. Self-healing Multi-nodal Alternate Route Topology Ring (Cont'd)

13. SMARTRing service (a.k.a. BellSouth Dedicated Ring) Overlay Ring Arrangements are available as follows:

**Overlaying SMARTRing service
 (a.k.a. BellSouth Dedicated Ring)**

**Host SMARTRing service
 (a.k.a. BellSouth Dedicated Ring)**

	OC-12	OC-48	OC-48+	OC-192	OC-192+
OC-1	X	X	X	X	X
OC-3	X	X	X	X	X
OC-3+		X	X	X	X
OC-12		X	X	X	X
OC-48				X	X
OC-48+					X

14. SMARTRing service (a.k.a. BellSouth Dedicated Ring) is connectible at Company Central Offices to any 44.736 Mbps and/or 1.544 Mbps services as provided in Section E7. of this Tariff. Rates and charges for such other services are as set forth in the applicable sections of this tariff for such other services.

Note 1: Effective on or after December 1, 2021, neither new nor existing customers will be permitted to purchase new SMARTRing Service (Service). In addition, (A) Service Payment Plans greater than 12-months in length will no longer be available; and (B) requests to move, add, change, upgrade, or downgrade existing service arrangements will not be accepted, with the following exceptions: (1) existing customers will be permitted to modify their existing Service and will be able to add new circuits to their existing Service, but will not be permitted to add new nodes in any locations; and (2) any such new circuits will be subject to the customer's existing term payment plan or term agreement for the Service to which they are added. Following the expiration of a customer's existing term agreement, Service will be provided on a month-to-month basis at the applicable Month-to-Month rates until the Service is discontinued. Effective November 30, 2023, unless specified to the contrary in their existing Service agreements, existing customers may not renew Term Payment Plans or term agreements for Service. In addition, no move, add, or change orders of any type will be accepted.

**KENTUCKY
 PUBLIC SERVICE COMMISSION**

Linda C. Bridwell
 Executive Director



**EFFECTIVE
 12/1/2021**

PURSUANT TO 807 KAR 5:011 SECTION 9 (1)

E7. SPECIAL ACCESS (A.K.A. BELLSOUTH SPA) SERVICE

E7.2 Service Descriptions (Cont'd)

E7.2.16 SMARTRing¹ Service (a.k.a. BellSouth Dedicated Ring) (Cont'd)

A. Self-healing Multi-nodal Alternate Route Topology Ring (Cont'd)

15. Shared Network Arrangements will not be provided with SMARTRing service (a.k.a. BellSouth Dedicated Ring) at the ring level. Shared Network Arrangements as defined in E2.6 preceding apply to DS1 channel interfaces only. (M1)

The customer must provide suitable floor space, controlled environment, and source of non-switched suitable power to support this service. (M1)

16. Where the customer provides two separate entrance facility cable routes for SMARTRing service (a.k.a. BellSouth Dedicated Ring), the primary and alternate entrance facilities will be separate and will enter the customer node over such different routes. When the customer requests a connection at a Customer Node via two local channels and Company facilities do not exist for the second Local Channel, the Company may provide an equivalent second Local Channel via an existing alternate route. When facilities become available for the second Local Channel, the Company may rearrange the alternate route at any time. (M1)

17. When the distance between nodes on a SMARTRing service (a.k.a. BellSouth SPA Dedicated Ring) is such that optical signal regeneration is required, then regeneration equipment will be provided at no additional charge to the customer to assure proper operation of the service. In some cases regeneration will be provided via SONET Add/Drop equipment called a Regeneration Node. A Regeneration Node does not contain the capability to add or drop services. Accordingly, FlexServ service (a.k.a. BellSouth SPA Customer Reconfiguration) Customer Network Management may not be ordered with a Regeneration Node, however, a customer may monitor a Regeneration Node via the FlexServ service (a.k.a. BellSouth SPA Customer Reconfiguration) Customer Network Management Surveillance option when a customer has established surveillance for a ring. Regeneration Node Surveillance is provided as a part of the charges associated with the customer's ring level FlexServ service (a.k.a. BellSouth SPA Customer Reconfiguration) Customer Network Management Surveillance. Regeneration Node and Regeneration Node Surveillance, as applicable, will appear on a customer's records as non-rated USOC(s), as follows: (M2)

	USOC
Regeneration Node, all ring capacities, non-rated	SHNRD
Regeneration Node Surveillance, all ring capacities, non-rated	SHNRS

- Note 1:** Effective on or after December 1, 2021, neither new nor existing customers will be permitted to purchase new SMARTRing Service (Service). In addition, (A) Service Payment Plans greater than 12-months in length will no longer be available; and (B) requests to move, add, change, upgrade, or downgrade existing service arrangements will not be accepted, with the following exceptions: (1) existing customers will be permitted to modify their existing Service and will be able to add new circuits to their existing Service, but will not be permitted to add new nodes in any locations; and (2) any such new circuits will be subject to the customer's existing term payment plan or term agreement for the Service to which they are added. Following the expiration of a customer's existing term agreement, Service will be provided on a month-to-month basis at the applicable Month-to-Month rates until the Service is discontinued. Effective November 30, 2023, unless specified to the contrary in their existing Service agreements, existing customers may not renew Term Payment Plans or term agreements for Service. In addition, no move, add, or change orders of any type will be accepted. (N)

**KENTUCKY
PUBLIC SERVICE COMMISSION**

Linda C. Bridwell
Executive Director



EFFECTIVE

12/1/2021

PURSUANT TO 807 KAR 5:011 SECTION 9 (1)

E7. SPECIAL ACCESS (A.K.A. BELLSOUTH SPA) SERVICE

E7.2 Service Descriptions (Cont'd)

E7.2.16 SMARTRing¹ Service (a.k.a. BellSouth Dedicated Ring) (Cont'd)

A. Self-healing Multi-nodal Alternate Route Topology Ring (Cont'd)

18. Effective February 16, 2007, Shared Node Interconnection is available, based on equipment capability, whereby two SMARTRing service arrangements belonging to the same customer may share a node in a central office that is common to both rings. Shared Node Interconnection capability is available based on equipment capability. With Shared Node Interconnection, one of the rings (i.e., the larger capacity ring) is considered the Primary Ring and the other ring is considered the Secondary Ring. Primary Rings may be an OC-12, OC-48 or an OC-192 ring. A Secondary Ring is always a lower capacity ring than that of the Primary Ring. The various Shared Node Interconnection service arrangements that are available are as follows:

<u>Shared Node Interconnection Primary Ring Capacity</u>	<u>Shared Node Interconnection Secondary Ring Capacity Available For Use With Primary Rings</u>			
	OC-3	OC-12	OC-48	OC-48+
OC-12	X			
OC-48	X	X		
OC-192	X	X	X	X

With Shared Node Interconnection, the Primary Ring shall have a Central Office Node and the Secondary Ring shall have a Shared Node Interconnection Central Office Node in the central office associated with the ring interconnection. For the Secondary Ring, a Shared Node Interconnection Central Office Node is considered toward meeting the three node minimum requirement for the Secondary Ring. This shared node will utilize capacity of the Primary Ring node, based on the size of the Secondary Ring, and will count toward the capacity the customer has available at the location. Should the customer require more capacity at a shared node central office location than is available on the Primary Ring node, then additional billable service components will be required.

Only one Shared Node Interconnection arrangement is available for an individual Central Office Node on a Primary Ring.

Reconfiguration is not allowed at central office nodes that are configured for Shared Node Interconnection.

Note 1: Effective on or after December 1, 2021, neither new nor existing customers will be permitted to purchase new SMARTRing Service (Service). In addition, (A) Service Payment Plans greater than 12-months in length will no longer be available; and (B) requests to move, add, change, upgrade, or downgrade existing service arrangements will not be accepted, with the following exceptions: (1) existing customers will be permitted to modify their existing Service and will be able to add new circuits to their existing Service, but will not be permitted to add new nodes in any locations; and (2) any such new circuits will be subject to the customer's existing term payment plan or term agreement for the Service to which they are added. Following the expiration of a customer's existing term agreement, Service will be provided on a month-to-month basis at the applicable Month-to-Month rates until the Service is discontinued.

Effective November 30, 2023, unless specified to the contrary in their existing Service agreements, existing customers may not renew Term Payment Plans or term agreements for Service. In addition, no move, add, or change orders of any type will be accepted.

**KENTUCKY
 PUBLIC SERVICE COMMISSION**

Linda C. Bridwell
 Executive Director



**EFFECTIVE
 12/1/2021**

PURSUANT TO 807 KAR 5:011 SECTION 9 (1)

E7. SPECIAL ACCESS (A.K.A. BELLSOUTH SPA) SERVICE

E7.2 Service Descriptions (Cont'd)

E7.2.16 SMARTRing¹ Service (a.k.a. BellSouth Dedicated Ring) (Cont'd)

A. Self-healing Multi-nodal Alternate Route Topology Ring (Cont'd)

B. Technical Specifications Packages

1. The compatibility requirements, technical specifications, and generic requirements for SMARTRing service (a.k.a. BellSouth Dedicated Ring) terminated at the customers designated locations are referenced in Technical Reference ANSI T1.404-1994, ANSI T1.403-1989 and ANSI T1.105-1991.
2. DS3 interface combinations and technical specifications are referenced in Bellcore TR-INS-000342.
3. DS1 interface combinations and technical specifications are referenced in Bellcore TR-NPL-000054.
4. STS-1, OC-1, OC-3, and OC-12 interface combinations and technical specifications are referenced in BellSouth Telecommunications, Inc. Technical Reference TR-73582.
5. These self-healing multi-nodal DS3 high capacity (a.k.a. BellSouth SPA DS3) service channels have a long term performance objective of 99.5 percent error-free seconds and a severely errored second (SES) objective of less than 0.009 percent SES when the circuit is available. Self-healing multi-nodal DS1 high capacity (a.k.a. BellSouth SPA DS1) service channels have a long term performance objective of 99.95 percent error-free seconds.

E7.2.17 Reserved For Future Use

Note 1: Effective on or after December 1, 2021, neither new nor existing customers will be permitted to purchase new SMARTRing Service (Service). In addition, (A) Service Payment Plans greater than 12-months in length will no longer be available; and (B) requests to move, add, change, upgrade, or downgrade existing service arrangements will not be accepted, with the following exceptions: (1) existing customers will be permitted to modify their existing Service and will be able to add new circuits to their existing Service, but will not be permitted to add new nodes in any locations; and (2) any such new circuits will be subject to the customer's existing term payment plan or term agreement for the Service to which they are added. Following the expiration of a customer's existing term agreement, Service will be provided on a month-to-month basis at the applicable Month-to-Month rates until the Service is discontinued.

Effective November 30, 2023, unless specified to the contrary in their existing Service agreements, existing customers may not renew Term Payment Plans or term agreements for Service. In addition, no move, add, or change orders of any type will be accepted.

**KENTUCKY
PUBLIC SERVICE COMMISSION**

Linda C. Bridwell
Executive Director



EFFECTIVE

12/1/2021

PURSUANT TO 807 KAR 5:011 SECTION 9 (1)

E7. SPECIAL ACCESS (A.K.A. BELLSOUTH SPA) SERVICE

E7.2 Service Descriptions (Cont'd)

E7.2.18 BellSouth Metro Ethernet Service²

(C)

- A. BellSouth Metro Ethernet service is a high-speed packet transport that is based on Ethernet transmission parameters. BellSouth Metro Ethernet service provides various transport capabilities that range from 2 Mbps through 1 Gbps with capabilities for basic, premium and virtual arrangements that may be used to meet individual customer needs.
- B. BellSouth Metro Ethernet service signals meet IEEE 802.3, 802.3u, or 802.3z standards. BellSouth Metro Ethernet service also uses 802.1Q VLAN tagging and stacking for certain service configurations contained herein. Technical requirements for interfaces with customer premises equipment (CPE) are contained in ANSI/IEEE 802.3-2002 Specifications.
- C. BellSouth Metro Ethernet service interface specifications are set forth in BellSouth Technical Reference TR-73632. Technical limitations associated with provisioning 2 Mbps, 4 Mbps and 8 Mbps BellSouth Metro Ethernet Connections based upon distance from the customer's premises to serving wire center and equipment configurations exist and are also set forth in TR-73632.
- D. The rates and charges set forth in E7.5.22 following for BellSouth Metro Ethernet service provide for the furnishing of service in certain metropolitan areas where suitable Company facilities are available. In locations where BellSouth Metro Ethernet service is not available, special construction charges may apply.
- E. A LAN (local area network) is a communications network spanning a limited geographical area. A LAN connects computers and other peripheral equipment for data communications purposes within a building or campus environment.
- F. A VLAN (virtual local area network) is a logical grouping of Metro Ethernet connections that allows data transmission between such connections to occur as if all connections are on the same physical LAN.
- G. Metro Ethernet is a service where Local Area Networks (LANs) send bi-directional Ethernet traffic to other LANs on an Ethernet Wide Area Network (WAN). Ethernet is one of the most widely deployed LAN/WAN standards. BellSouth Metro Ethernet service supports IEEE Standard 802.3, 802.3u and 802.3z transmission standards.
- H. A Metro Ethernet Customer Network is defined as the set of interconnected Metro Ethernet connections assigned to the same VLAN within the BellSouth core network. Premium Connections that include the Q-Forwarding optional feature described in O. following and Virtual Connections that include the VLAN Aggregation optional feature described in P. following may be part of more than one Metro Ethernet Customer Network.
- I. A Basic BellSouth Metro Ethernet service Connection provides 2 Mbps, 4 Mbps, 8 Mbps, 10 Mbps, 100 Mbps and 1 Gbps Ethernet capabilities that are a part of a BellSouth Metro Ethernet service network within a metropolitan area. Basic BellSouth Metro Ethernet service is a best effort service with service capabilities that are affected by overall traffic on the Basic BellSouth Metro Ethernet service network and is suitable for data transmission only.

A Basic BellSouth Metro Ethernet service connection operating at any of these speeds is capable of interconnecting with other Basic BellSouth Metro Ethernet service Connections that are operating at any of these speeds in the same metropolitan area.

A Basic BellSouth Metro Ethernet service connection provides data channel transport that connects customer premises¹ that are 10 miles or less in distance from the BellSouth Metro Ethernet service wire center associated with the Basic BellSouth Metro Ethernet service Connection. Customer locations¹ greater than 10 miles from the Basic BellSouth Metro Ethernet service wire center also require BellSouth Metro Ethernet service Additional Mileage charges.

Note 1: And as alternatively set forth in E7.4.32.A.5. *and 6.* following.

Note 2: Effective on or after August 22, 2021, this Service will no longer be available for purchase by new or existing customers. In addition, requests to move, add, change, or renew existing service arrangements will not be accepted. Following the expiration of a customer's existing term agreement, service will be provided on a month-to-month basis at the applicable Monthly rates until the service is discontinued. The Company currently plans to discontinue this service on or after March 31, 2023.

(N)
|
(N)

KENTUCKY PUBLIC SERVICE COMMISSION
Linda C. Bridwell Executive Director

EFFECTIVE 8/22/2021 PURSUANT TO 807 KAR 5:011 SECTION 9 (1)

E7. SPECIAL ACCESS (A.K.A. BELLSOUTH SPA) SERVICE

E7.2 Service Descriptions (Cont'd)

E7.2.18 BellSouth Metro Ethernet Service (Cont'd)³

(C)

- J.** A Premium BellSouth Metro Ethernet service Connection provides 2 Mbps, 4 Mbps, 8 Mbps, 10 Mbps, 20 Mbps, 50 Mbps, 100 Mbps, 250 Mbps, 500 Mbps and 900 Mbps Ethernet capabilities that are a part of a BellSouth Metro Ethernet service network within a metropolitan area. Premium BellSouth Metro Ethernet service provides the ability to order Ethernet Service with improved service characteristics to meet customer needs regarding the assurance of bandwidth availability.

Premium BellSouth Metro Ethernet service provides customer capabilities to assure service characteristics via ordering a Committed Bandwidth (CBW). A CBW is the minimum bandwidth across the BellSouth Metro Ethernet service network within a metropolitan area between a customer's Premium BellSouth Metro Ethernet service locations.

Premium BellSouth Metro Ethernet service Connections are available with "Fixed" and "Burst" capabilities unless specified otherwise¹. With the Fixed arrangement, Premium BellSouth Metro Ethernet service Connections will have the bandwidth ordered (e.g., 10 Mbps) available across the BellSouth Metro Ethernet service network. With the Burst arrangement, Premium BellSouth Metro Ethernet service Connections will have the ability to send burst of data above their CBW rate, if network capacity *and facilities are* available. For example, a 10 Mbps, a 20 Mbps and a 50 Mbps Connection may Burst up to 100 Mbps, while a 100 Mbps, a 250 Mbps and a 500 Mbps Connection may Burst up to 1 Gbps.

A Premium BellSouth Metro Ethernet service Connection operating at any of these speeds is capable of interconnecting with other Premium BellSouth Metro Ethernet service Connections that are operating at any of these speeds in the same metropolitan area.

A Premium BellSouth Metro Ethernet service Connection provides data channel transport that connects customer premises² that are 10 miles or less in distance from the BellSouth Metro Ethernet service wire center associated with the Premium BellSouth Metro Ethernet service Connection. Customer locations² greater than 10 miles from the Premium BellSouth Metro Ethernet service wire center also require BellSouth Metro Ethernet service Additional Mileage charges.

Note 1: Premium Connections at 2 Mbps, 4 Mbps, 8 Mbps and 900 Mbps are available only as Fixed arrangements (i.e., "Burst" capability is not available).

Note 2: And is alternatively set forth in E7.4.32.A.5. and 6. following.

Note 3: Effective on or after August 22, 2021, this Service will no longer be available for purchase by new or existing customers. In addition, requests to move, add, change, or renew existing service arrangements will not be accepted. Following the expiration of a customer's existing term agreement, service will be provided on a month-to-month basis at the applicable Monthly rates until the service is discontinued. The Company currently plans to discontinue this service on or after March 31, 2023.

(N)
|
(N)

**KENTUCKY
PUBLIC SERVICE COMMISSION**

Linda C. Bridwell
Executive Director



EFFECTIVE

8/22/2021

PURSUANT TO 807 KAR 5:011 SECTION 9 (1)

E7. SPECIAL ACCESS (A.K.A. BELLSOUTH SPA) SERVICE

E7.2 Service Descriptions (Cont'd)

E7.2.18 BellSouth Metro Ethernet Service (Cont'd)²

(C)

K.

- L. A Virtual BellSouth Metro Ethernet Service Connection provides 2 Mbps, 4 Mbps, 8 Mbps, 10 Mbps, 20 Mbps, 50 Mbps, 80 Mbps, 100 Mbps, 200 Mbps, 300 Mbps, 450 Mbps, 600 Mbps, 750 Mbps and 900 Mbps Ethernet capabilities that are a part of a BellSouth Metro Ethernet Service network within a metropolitan area. Virtual BellSouth Metro Ethernet Service provides the ability to order Ethernet Service where a single customer connection can support multiple applications with varying Quality of Service (QoS) features and Classes of Service.

Virtual BellSouth Metro Ethernet Service provides customer capabilities to support different Classes of Service (CoS) (i.e., Real-Time, Interactive, Business Critical and Best Effort as described in E7.2.18.T) over the same Connection and offers customers increased flexibility to match bandwidth to their real needs for voice/data/video applications on each Connection. The customer orders the percentage of their Virtual BellSouth Metro Ethernet Service Connection bandwidth that will be allocated for each class of service.

For each Virtual Connection, the customer's bandwidth will be limited to the fixed speed associated with each CoS level specified in the CoS profile selected for the Virtual Connection.

A Virtual BellSouth Metro Ethernet Service Connection operating at any of these speeds is capable of interconnecting with other Virtual BellSouth Metro Ethernet Service Connections that are operating at any of these speeds in the same metropolitan area.

A Virtual BellSouth Metro Ethernet Service Connection provides data channel transport that connects customer premises¹ that are 10 miles or less in distance from the BellSouth Metro Ethernet Service wire center associated with the Virtual BellSouth Metro Ethernet Service Connection. Customer locations¹ greater than 10 miles from the Virtual BellSouth Metro Ethernet Service wire center also require BellSouth Metro Ethernet Service Additional Mileage charges.

Note 1: And as alternatively set forth in E7.4.32.A.5. *and 6.* following.

Note 2: Effective on or after August 22, 2021, this Service will no longer be available for purchase by new or existing customers. In addition, requests to move, add, change, or renew existing service arrangements will not be accepted. Following the expiration of a customer's existing term agreement, service will be provided on a month-to-month basis at the applicable Monthly rates until the service is discontinued. The Company currently plans to discontinue this service on or after March 31, 2023.

(N)

(N)



E7. SPECIAL ACCESS (A.K.A. BELLSOUTH SPA) SERVICE

E7.2 Service Descriptions (Cont'd)

E7.2.18 BellSouth Metro Ethernet Service (Cont'd)²

- M. BellSouth Metro Ethernet service Additional Mileage charges associated with a BellSouth Metro Ethernet service Connection apply when the total distance from the customer premises¹ to the BellSouth Metro Ethernet service wire center associated with the service serving the customer premises¹ is greater than 10 miles in length. The additional mileage is measured in airline miles from the customer premises¹ to the BellSouth Metro Ethernet service wire center associated with the BellSouth Metro Ethernet service. Fractions of miles will be considered as a whole mile.

BellSouth Metro Ethernet service Additional Mileage charges apply to Basic, Premium and Virtual BellSouth Metro Ethernet service based on the service's speed and the total distance associated with the data channel. The BellSouth Metro Ethernet service Additional Mileage Charge is based on the mileage band the total data channel mileage falls into. For example, a data channel that is 30 miles in length would be charged the additional mileage rate for the greater than 25 mile through 35 mile band.

- N. Priority Plus is an optional feature available to customers with Premium BellSouth Metro Ethernet service. Priority Plus provides the customer with the ability to prioritize their traffic in accordance with a predefined hardware queue model approach. With this option, customers will assign priority values to their data and higher-priority data will be transmitted first. Priority Plus service traffic is limited to a small subset of the total Committed Bandwidth (CBW) traffic and is marked for expedited handling within the Metro Ethernet Service. Customers that desire Priority Plus must establish it for all of their Premium BellSouth Metro Ethernet service Connections within that Metro Ethernet Customer Network.
- O. Q-Forwarding is an optional feature available to customers with Premium BellSouth Metro Ethernet service. Q-Forwarding provides VLAN aggregation across a common physical connection. This feature supports customer aggregation of traffic from multiple Metro Ethernet Customer Networks (referred to as VLANS). This aggregated traffic can be transported back to a central location and across a common Metro Ethernet Service Connection (referred to as the "aggregation" connection). Q-Forwarding utilizes IEEE 802.1Q VLAN Tagging procedures.

While Q-Forwarding is available with BellSouth Premium Metro Ethernet Connections at 2 Mbps, 4 Mbps and 8 Mbps, this feature is subject to technical limitations set forth in Technical Reference 73632 when used with these speed connections.

With Q-Forwarding, special technical considerations set forth in Technical Reference 73632 must be taken into account to determine the customer's CBW across their BellSouth Metro Ethernet Network.

The Q-Forwarding Service Establishment Charge is a charge to provision a Premium Metro Ethernet Connection with the Q-Forwarding feature and identify it as an "aggregation" connection.

The Q-Forwarding Network Assignment Charge is a charge to provision each Metro Ethernet Customer Network to the Q-Forwarding "aggregation" connection. The Q-Forwarding Network Assignment Charge applies for each VLAN connected to the Q-Forwarding "aggregation" connection.

- P. VLAN Aggregation is an optional feature available to customers with Virtual BellSouth Metro Ethernet Service. VLAN Aggregation provides VLAN aggregation across a common physical connection. This feature supports customer aggregation of traffic from multiple Metro Ethernet Customer Networks (referred to as VLANS) comprised of Virtual Connections. This aggregated traffic can be transported back to a central location and across a common Virtual Metro Ethernet Service Connection (referred to as the "aggregation" connection). VLAN Aggregation utilizes IEEE 802.1Q VLAN Tagging procedures.

While VLAN Aggregation is available with BellSouth Virtual Metro Ethernet Connections at 2 Mbps, 4 Mbps and 8 Mbps, this feature is subject to technical limitations set forth in Technical Reference 73632 when used with these speed connections.

The VLAN Aggregation Service Establishment Charge is a charge to provision a Virtual Metro Ethernet Connection with this feature and identify it as an "aggregation" connection.

The VLAN Aggregation Network Assignment Charge is a charge to provision each Virtual Ethernet Customer Network to the "aggregation" connection. The VLAN Aggregation Network Assignment Charge applies for each VLAN connected to the "aggregation" connection.

Note 1: And as alternatively set forth in E7.4.32.A.5. and 6. following.

Note 2: Effective on or after August 22, 2021, this Service will no longer be available for purchase by new or existing customers. In addition, requests to move, add, change, or renew existing service arrangements of a customer's existing term agreement, service will be provided on a month-to-month basis until the service is discontinued. The Company currently plans to discontinue this

KENTUCKY PUBLIC SERVICE COMMISSION
Linda C. Bridwell Executive Director

EFFECTIVE 8/22/2021 PURSUANT TO 807 KAR 5:011 SECTION 9 (1)

(C)

(N)
|
(N)

E7. SPECIAL ACCESS (A.K.A. BELLSOUTH SPA) SERVICE

E7.2 Service Descriptions (Cont'd)

E7.2.18 BellSouth Metro Ethernet Service (Cont'd)¹

(C)

- Q. Customer Network Management (CNM)** - Metro Ethernet Reporting is an optional feature available to customers with Premium or Virtual BellSouth Metro Ethernet service. **CNM** - Metro Ethernet Reporting provides customers a view into their BellSouth Metro Ethernet service network via the use of a web interface and security card. **CNM** - Metro Ethernet Reporting provides alarm surveillance, service level agreement reporting and performance reporting for the various network components that comprise the customer's BellSouth Metro Ethernet service network. This feature is only available to customers purchasing Premium or Virtual BellSouth Metro Ethernet service.

Customers who subscribe to **CNM** - Metro Ethernet Reporting must monitor their entire BellSouth Metro Ethernet Network. The **CNM** - Metro Ethernet Reporting Charge is applicable for each Premium or Virtual Metro Ethernet Service Connection.

The **CNM** - Metro Ethernet Reporting Service Establishment Charge is a nonrecurring charge that applies to initially establish a new Metro Ethernet Service customer account. A customer with an existing **CNM** - Metro Ethernet Reporting customer account from another BellSouth jurisdiction may re-use that customer account.

All customers purchasing **CNM** - Metro Ethernet Reporting must have a web interface that will allow the customer to access and monitor their network via the web. Each web interface provides for one concurrent access. Additional concurrent accesses will require additional web interfaces. An initial web interface (Web Interface Charge - First) is provided with the initial establishment of a customer account. A monthly charge and a nonrecurring charge are applicable for each additional web interface requested for a customer account (Web Interface Charge – Each Additional).

A security card is required to access a web interface. Each security card can only be used for a single concurrent access and can be associated with only one web interface. A Security Card Charge will apply for the initial and additional cards requested and for the issuance of additional cards to replace lost, damaged or expired cards. A nonrecurring charge is applicable per security card requested.

- R.** BellSouth Metro Ethernet service Customer networks comprised of Premium Connections or Virtual Connections with **CNM** - Metro Ethernet Reporting are provided Service Level Agreements (SLAs) for the Company's repair and performance commitments for this service. Credits are provided for missed commitments on such service. The specific SLA commitments and credits applicable are set forth in E7.4.32.C. following for Premium Connections and in E7.4.32.D. for Virtual Connections.

- S.** Subsequent to its initial installation, a customer may request to reconfigure or change a BellSouth Metro Ethernet service Connection. The Service Reconfiguration Charge or System Reconfiguration Charge will be the nonrecurring charge applicable for such a request; the appropriate nonrecurring charge will be based upon the reconfiguration or change requested, as specifically described and set forth in E7.4.32 following.

- T.** For each Virtual BellSouth Metro Ethernet Connection the customer must decide the mix of applications that will be supported on that Connection, the CoS mix that Virtual Connection must support, and the percentage of bandwidth to be assigned for each CoS (i.e., build a CoS profile for each Virtual Connection). The customer's bandwidth will be limited to the fixed speed associated with each CoS level. Therefore, total bandwidth available to support transmission of a specific CoS will depend upon the size of the customer's Connection and the specific CoS percentage the customer selected for that Connection.

A customer may request a single CoS or up to four CoS to build the CoS Profile for a Virtual Connection. The customer determines the percentage bandwidth each CoS selected should be of the total Virtual Connection's bandwidth. The sum of the percentages for each CoS selected for a Virtual Connection must equal 100%. Additionally, the combined CoS bandwidth percentages selected in a customer's CoS Profile for Real-Time CoS plus Interactive CoS may not exceed 50%, except where the customer selects the 70% Real-Time CoS bandwidth percentage and has no Interactive traffic.

A customer may select different CoS profiles for different Virtual Connections that share the same network VLAN, or Virtual Connection network arrangement. However, technical limitations exist as discussed in TR-73632 that limit the total number of different CoS profiles that can be utilized in a single Virtual Connection network arrangement.

Note 1: Effective on or after August 22, 2021, this Service will no longer be available for purchase by new or existing customers. In addition, requests to move, add, change, or renew existing service arrangements will not be accepted. Following the expiration of a customer's existing term agreement, service will be provided on a month-to-month basis at the applicable monthly rates until the service is discontinued. The Company currently plans to discontinue this service on or after March 31, 2023.

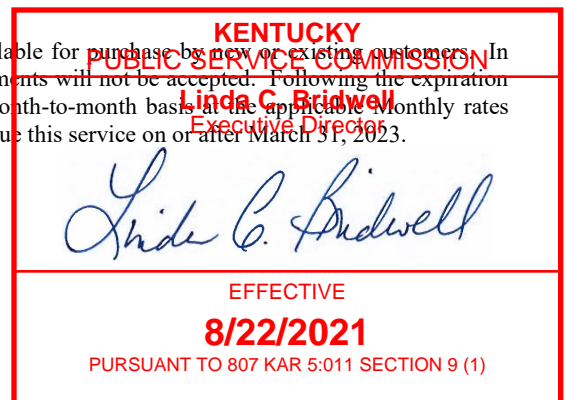

E7. SPECIAL ACCESS (A.K.A. BELLSOUTH SPA) SERVICE

E7.2 Service Descriptions (Cont'd)

E7.2.18 BellSouth Metro Ethernet Service (Cont'd)²

(C)

T. (Cont'd)

The CoS and percentage bandwidth selected for a Virtual Connection will define the applications that can be supported and its Quality of Service (QoS) attributes such as traffic priority, latency, packet loss rate, etc. QoS attributes are defined for each CoS. Each Virtual Connection will support Ethernet traffic representing one or more applications and CoS. Virtual Connections support the four following CoS:

- Real-Time¹: This CoS supports VoIP applications. The Real-Time CoS is supported by a low latency queue. The Low Latency Queuing (LLQ) feature in the Ethernet network is used for support of the Real-Time CoS.
- Interactive¹: This CoS supports interactive Video applications. The Interactive CoS is policed to a maximum bandwidth.
- Business Critical: This CoS supports mission-critical business data applications. These applications tend to be data specific and may include medical imaging, electronic funds transfer, medical records transfer, etc.
- Best Effort: This CoS is the default CoS for all other traffic that is not defined as Business Critical, Real-Time or Interactive. Traffic that does not match the other CoS will be mapped as Best Effort. Traffic with the Best Effort CoS will have the lowest priority on the network and will support lower priority data applications, such as email and file transfer protocol (FTP).

Each customer packet from a Virtual Connection will be classified and assigned to a specific CoS by methods identified in TR-73632.

Note 1: The combined CoS bandwidth percentages selected in a customer's Virtual Connection CoS profile for Real-Time CoS plus Interactive CoS may not exceed 50%, except where the customer selects the 70% Real-Time CoS bandwidth percentage and has no Interactive traffic.

Note 2: Effective on or after August 22, 2021, this Service will no longer be available for purchase by new or existing customers. In addition, requests to move, add, change, or renew existing service arrangements will not be accepted. Following the expiration of a customer's existing term agreement, service will be provided on a month-to-month basis at the applicable Monthly rates until the service is discontinued. The Company currently plans to discontinue this service on or after March 31, 2023.

(N)
|
(N)



E7. SPECIAL ACCESS (A.K.A. BELLSOUTH SPA) SERVICE

E7.2 Service Descriptions (Cont'd)

E7.2.18 BellSouth Metro Ethernet Service (Cont'd)²

- U. Automatic Protection Switching (APS) is an optional feature available, except as specified otherwise herein, to customers with a Basic, Premium or Virtual BellSouth Metro Ethernet Service Connection of 10 Mbps or higher¹. The APS feature provides customers with the option of having data channel (i.e., facilities from the customer premises to the BellSouth Metro Ethernet Service wire center) survivability through the use of a secondary transport path that is diverse from the path provided with their primary Metro Ethernet Connection. This secondary transport path (i.e., data channel) is provided for a specific Metro Ethernet Connection (i.e., the primary) with the selection of the APS feature which then provides the customer with complete path protection. However, APS is not available for a 2 Mbps, 4 Mbps or 8 Mbps Connection.

With APS, the primary Metro Ethernet Connection's data channel is monitored for threshold violations or path failures with a fail-over to the secondary data channel path provided via the APS feature. The APS data channel is checked periodically to ensure its availability if a failure of the primary Metro Ethernet Connection's data channel occurs.

APS may be ordered as a structurally diverse transport path (Structural Protection) or a route diverse transport path (Route Protection).

Structural Protection APS is defined as the APS facility and the primary Metro Ethernet Connection facility being in separate sheaths in separate structures located along the same route (e.g., underground/underground, buried/underground, aerial/underground, aerial/buried, buried/buried, and aerial/aerial), or along different routes at the Telephone Company's discretion

Route Protection APS is defined as the APS facility being in a separate sheath within alternate underground, aerial or direct buried structures that are run along separate physical paths from the facilities associated with the primary Metro Ethernet Connection. No precise distance separation is specified between the paths; although the separation is sufficient to preclude one disruptive event from affecting both routes.

The APS feature is billed based upon the actual total route miles in a customer's specific Structural Protection APS or Route Protection APS design as determined by the Telephone Company. The term "route miles" is defined for this application to be the actual physical distance or length (not airline mileage), rounded up to the next whole mile, of the unique APS facility designed for each individual customer premises. Total route miles are measured between the customer premises and its serving wire center, plus route miles between the serving wire center and any intermittent wire centers in the path designed to reach the BellSouth Metro Ethernet wire center associated with the primary Metro Ethernet Connection (i.e., the wire center where the BellSouth Metro Ethernet switching equipment is located).

The APS rate element provides the alternate data channel transport and APS equipment in the BellSouth Metro Ethernet Service wire center associated with the primary Metro Ethernet Connection. Actual total route mileage for the customer's APS design is determined from a Service Inquiry. The route mileage determined from this Telephone Company Service Inquiry is used for billing purposes and is the sole determinant of such mileage (i.e., not subject to dispute).

- V. BellSouth Metro Ethernet Service Independent Company (ICO) Trunk Connection

Provides interconnection between BellSouth's Ethernet network and the Ethernet network of an Independent Telephone Company. A BellSouth Metro Ethernet Service ICO Trunk Connection provides data channel transport for connections that are 10 airline miles or less in distance from the BellSouth Metro Ethernet Service ICO Trunk Connection wire center to the meet-point with the Independent Company. Meet-point locations greater than 10 airline miles from the BellSouth Metro Ethernet Service ICO Trunk Connection wire center also require BellSouth Metro Ethernet Service ICO Trunk Additional Mileage charges.

- W. BellSouth Metro Ethernet Service Independent Company (ICO) Trunk Additional Mileage Charges

Additional mileage charges associated with a BellSouth Metro Ethernet Service ICO Trunk Connection apply when the total distance from the BellSouth Metro Ethernet Service ICO Trunk Connection wire center to the meet-point with the Independent Company is greater than 10 miles in length. The additional mileage is measured in airline miles from the BellSouth Metro Ethernet Service wire center associated with the BellSouth Metro Ethernet Service ICO Trunk Connection to the Independent Company meet-point. Fractions of miles will be considered as a whole mile.

Note 1: Automatic Protection Switching (APS) is not available for a 2 Mbps, 4 Mbps or 8 Mbps Basic, Premium or Virtual Connection.

Note 2: Effective on or after August 22, 2021, this Service will no longer be available for purchase by new or existing customers. In addition, requests to move, add, change, or renew existing service arrangements will not be accepted. Following the expiration of a customer's existing term agreement, service will be provided on a month-to-month basis until the service is discontinued. The Company currently plans to discontinue this

**KENTUCKY
PUBLIC SERVICE COMMISSION**

**Linda C. Bridwell
Executive Director**



**EFFECTIVE
8/22/2021
PURSUANT TO 807 KAR 5:011 SECTION 9 (1)**

(C)

(N)
—
(N)

E7. SPECIAL ACCESS (A.K.A. BELLSOUTH SPA) SERVICE

E7.2 Service Descriptions (Cont'd)

E7.2.18 BellSouth Metro Ethernet Service (Cont'd)¹

(C)

X. Migration to AT&T Switched Ethernet ServiceSM

Customers subscribing to BellSouth Metro Ethernet Service may migrate to AT&T Switched Ethernet Service provided by the Company without incurring termination charges, subject to the following conditions:

- The new AT&T Switched Ethernet Service and the existing BellSouth Metro Ethernet Service must be billed to the same customer of record at the same customer locations.
- The customer's existing service must have been in place for at least 12 months.
- The minimum term for the new service must be at least 12 months and must be equal to or greater than the number of months remaining in the customer's existing Transport Payment Plan (TPP) term.
- The speed (capacity/bandwidth) of the new service must be equal to or greater than that of the existing service.
- The customer must issue a disconnect order for the replaced BellSouth Metro Ethernet Service to be effective within 90 days after the AT&T Switched Ethernet Service installation date. The disconnect and new orders must be coordinated through the Company.
- If overlapping service is required, the period will be limited to not more than 90 days and billing will apply to both services during the time both services are available.

Note 1: Effective on or after August 22, 2021, this Service will no longer be available for purchase by existing customers. In addition, requests to move, add, change, or renew existing service arrangements will not be accepted until the expiration of a customer's existing term agreement, service will be provided on a month-to-month basis until the service is discontinued. The Company currently plans to discontinue this service.



(N)
|
(N)

E7. SPECIAL ACCESS (A.K.A. BELLSOUTH SPA) SERVICE

E7.3 Channel Interface And Network Channel Codes

This section explains the Channel Interface codes and Network Channel codes that the customer must specify when ordering Special Access (a.k.a. BellSouth SPA) service. Included is an example which explains the specific characters of the code, a glossary of Channel Interface codes, impedance levels, Network Channel codes and compatible Channel Interfaces.

Example: If the customer specifies a NT Network Channel Code and a 2DC8-3 Channel Interface at the customer's premises, the following is being requested:

NT = Metallic¹ Channel with a Predefined Technical Specification Package (1) (C)

2 = Number of physical wires at customer premises

DC = Facility interface for direct current or voltage

8 = Variable impedance level

3 = Metallic¹ facilities (DC continuity) for direct current/low frequency control signals or slow speed data (30 baud) (C)

E7.3.1 Glossary Of Channel Interface Codes And Options

Code - Option	Definition	
AB -	Accepts 20 Hz ringing signal at customer's point of termination	
AC -	Accepts 20 Hz ringing signal at the customer's end user's point of termination	
CS -	Digital hierarchy interface at Digital Crossconnect System (DCS)	
- EA	E & M Signaling	
- GO	Ground Start Loop Signaling-Open End	
- GS	Ground Start Loop Signaling-Closed End	
- LO	Loop Start Loop Signaling-Open End	
- LS	Loop Start Loop Signaling-Closed End	
- NO	Transmission Only - No Signaling	
- R	(DS0) Customer Reconfigurable Voice Grade ¹ Service	(C)
- 10R	DS1 to DS0 Customer Reconfigurable ¹	(C)
- 10	DS1 to DS0 ¹	(C)
- 11R	DS1 to DS1 Customer Reconfigurable	
- 11	DS1 to DS1	
- SP	Resistive Type: Split Path Operation for Data Polling Conference Type	
- CF	Resistive Type: Split Path Operation for Symmetrical Voice Conference Type	
- BC	CO Bridging: Broadcast for Broadcast Conference Type	
CT -	Centrex Type Services Tie Trunk Termination	
DA -	Data stream in VF frequency band at customer's end user's point of termination	
DB -	Data stream in VF frequency band at customer's point of termination	
- 10	VF for TG1 and TG2	
- 43	VF for 43 Telegraph ¹ Carrier type signals, TG1 and TG2	(C)

Note 1: Effective June 30, 2021, this Service will no longer be available for purchase by new or existing customers. In addition, requests to move, add, change, or renew existing service arrangements will not be accepted. Following the expiration of a customer's existing term agreement, service will be provided on a month-to-month basis at the applicable Monthly rates until the service is discontinued. The Company currently plans to discontinue this service on or after June 30, 2024.

(N)
 |
 (N)

**KENTUCKY
 PUBLIC SERVICE COMMISSION**

Linda C. Bridwell
 Executive Director



**EFFECTIVE
 6/30/2021**

PURSUANT TO 807 KAR 5:011 SECTION 9 (1)

E7. SPECIAL ACCESS (A.K.A. BELLSOUTH SPA) SERVICE

E7.3 Channel Interface And Network Channel Codes (Cont'd)

E7.3.1 Glossary Of Channel Interface Codes And Options (Cont'd)

Code - Option	Definition	
DC -	Direct current or voltage	
- 1	Monitoring interface with series RC combination (McCulloh format)	
- 2	Company energized alarm channel	
- 3	Metallic ¹ facilities (DC continuity) for direct current/low frequency control signals or slow speed data (30 baud)	(C)

Note 1: Effective June 30, 2021, this Service will no longer be available for purchase by new or existing customers. In addition, requests to move, add, change, or renew existing service arrangements will not be accepted. Following the expiration of a customer's existing term agreement, service will be provided on a month-to-month basis at the applicable Monthly rates until the service is discontinued. The Company currently plans to discontinue this service on or after June 30, 2024.

(N)
|
(N)

KENTUCKY PUBLIC SERVICE COMMISSION
Linda C. Bridwell Executive Director 
EFFECTIVE 6/30/2021 PURSUANT TO 807 KAR 5:011 SECTION 9 (1)

BELLSOUTH
TELECOMMUNICATIONS, INC.
KENTUCKY
ISSUED: January 17, 1997
BY: E.C. Roberts, Jr., President - KY
Louisville, Kentucky

ACCESS SERVICES TARIFF

PSC KY. TARIFF 2E
Second Revised Page 23.1
Cancels First Revised Page 23.1
EFFECTIVE: February 16, 1997

E7. SPECIAL ACCESS (A.K.A. BELLSOUTH SPA) SERVICE

(T)

E7.3 Channel Interface And Network Channel Codes (Cont'd)

E7.3.1 Glossary Of Channel Interface Codes And Options (Cont'd)

Code - Option	Definition
DD -	Telemetry and Alarm Bridging interface at customer's point of termination
DE -	Telemetry and Alarm Bridging interface at the customer's end user's point of termination
DS -	Digital hierarchy interface
- 1K	1.544 Mbps (DS1) ANSI Extended Superframe (ESF) format per TA-TSY-000342
- 1S	1.544 Mbps (DS1) ANSI Extended Superframe (ESF) format and B8ZS Clear Channel Capability per TA-TSY-000342.
- 15	1.544 Mbps (DS1) Superframe (SF) format per TA-TSY-000342
- 15B	1.544 Mbps (DS1) Superframe (SF) format and B8ZS Clear Channel Capability per TA-TSY-000342
- 15E	8-bit PCM encoded in one 64 Kbps of the DS1 signal
- 15F	8-bit PCM encoded in two 64 Kbps of the DS1 signal

PUBLIC SERVICE COMMISSION
OF KENTUCKY
EFFECTIVE

FEB 16 1997

PURSUANT TO 807 KAR 5:011,
SECTION 9 (1)

BY: Jordan C. Neal
FOR THE PUBLIC SERVICE COMMISSION

E7. SPECIAL ACCESS (A.K.A. BELLSOUTH SPA) SERVICE

E7.3 Channel Interface And Network Channel Codes (Cont'd)

E7.3.1 Glossary Of Channel Interface Codes And Options (Cont'd)

Code - Option	Definition
- 15G	8-bit PCM encoded in three 64 Kbps of the DS1 signal
- 15H	14/11-bit PCM encoded in six 64 Kbps of the DS1 signal
- 15J	1.544 Mbps format per PUB 41451 (only available to U.S. Govt. agencies)
- 31	3.152 Mbps (DS1C)
- 31L	3.152 Mbps (DS1C) with SF signaling
- 44	44.736 Mbps (DS3)
- 44L	44.736 Mbps (DS3) with SF signaling
- 63	6.312 Mbps (DS2)
- 63L	6.312 Mbps (DS2) with SF signaling
DU -	Digital access interface
- 19(S)	9.2 Kbps ^{1,2}
- 24(S)	2.4 Kbps ^{1,2}
- 48(S)	4.8 Kbps ^{1,2}
- 56(S)	56.0 Kbps ^{1,2}
- 64	64.0 Kbps ²
- 96(S)	9.6 Kbps ^{1,2}
- 1KN	DS1 (1.544 Mbps) ANSI Extended Superframe (ESF) Format per TR-NPL-000054 without line power
- 1SN	DS1 (1.544 Mbps) ANSI Extended Superframe (ESF) Format per TR-NPL-000054, with B8ZS Clear Channel Capability and without line power
- A	DS1 (1.544 Mbps) free-framing format per PUB 41451 with line power (only available to U. S. Govt. agencies)
- AN	DS1 (1.544 Mbps) free-framing format per PUB 41451 without line power (only available to U. S. Govt. agencies)
- BN	DS1 (1.544 Mbps) Superframe (SF) Format per TR-NPL-000054 without line power
- DN	DS1 (1.544 Mbps) Superframe (SF) Format per TR-NPL-000054, with B8ZS Clear Channel Capability and without line power.
- SN	1.544 Mbps (DS1) ANSI Extended Superframe (ESF) format and B8ZS Clear Channel Capability
DV -	Data and Voice Multiplexing
- BC	Digital Data Over Voice, 9.6 Kbps ²

Note 1: (S) is an additional BellSouth designation for use when the optional Secondary Channel feature is required.

Note 2: Effective June 30, 2021, this Service will no longer be available for purchase by new or existing customers. In addition, requests to move, add, change, or renew existing service arrangements will not be accepted. Following the expiration of a customer's existing term agreement, service will be provided on a month-to-month basis at the applicable Monthly rates until the service is discontinued. The Company currently plans to discontinue this service on or after June 30, 2024.

(C)
 (C)

(N)
 (N)

**KENTUCKY
 PUBLIC SERVICE COMMISSION**

Linda C. Bridwell
 Executive Director



**EFFECTIVE
 6/30/2021**

PURSUANT TO 807 KAR 5:011 SECTION 9 (1)

BELLSOUTH
TELECOMMUNICATIONS, INC.
KENTUCKY
ISSUED: January 17, 1997
BY: E.C. Roberts, Jr., President - KY
Louisville, Kentucky

ACCESS SERVICES TARIFF

PSC KY. TARIFF 2E
First Revised Page 24.1
Cancels Original Page 24.1
EFFECTIVE: February 16, 1997

E7. SPECIAL ACCESS (A.K.A. BELLSOUTH SPA) SERVICE

(T)

E7.3 Channel Interface And Network Channel Codes (Cont'd)

E7.3.1 Glossary Of Channel Interface Codes And Options (Cont'd)

Code - Option	Definition
DX -	Duplex signaling interface at customer's point of termination
DY -	Duplex signaling interface at customer's end user's point of termination.
EA - E	Type I E&M Lead Signaling. Customer at POT or customer's end user at POT originates on E Lead.
EA - M	Type I E&M Lead Signaling. Customer at POT or customer's end user at POT originates on M Lead.
EB - E	Type II E&M Lead Signaling. Customer at POT or customer's end user at POT originates on E Lead.
EB - M	Type II E&M Lead Signaling. Customer at POT or customer's end user at POT originates on M Lead.
EC -	Type III E&M signaling at customer POT.

PUBLIC SERVICE COMMISSION
OF KENTUCKY
EFFECTIVE

FEB 16 1997

PURSUANT TO 807 KAR 5.011,
SECTION 9 (1)

BY: Jordan C. Meek
FOR THE PUBLIC SERVICE COMMISSION

BELLSOUTH
TELECOMMUNICATIONS, INC.
KENTUCKY
ISSUED: January 17, 1997
BY: E.C. Roberts, Jr., President - KY
Louisville, Kentucky

ACCESS SERVICES TARIFF

PSC KY. TARIFF 2E
Fourth Revised Page 25
Cancels Third Revised Page 25
EFFECTIVE: February 16, 1997

E7. SPECIAL ACCESS (A.K.A. BELLSOUTH SPA) SERVICE

(T)

E7.3 Channel Interface And Network Channel Codes (Cont'd)

E7.3.1 Glossary Of Channel Interface Codes And Options (Cont'd)

Code - Option	Definition
EX - A	Tandem channel unit signaling for loop start or ground start and customer supplies open end (dial tone, etc.) functions.
- B	Tandem channel unit signaling for loop start or ground start and customer supplies closed end (dial pulsing, etc.) functions.
GO -	Ground start loop signaling - open end function by customer or customer's end user
GS -	Ground start loop signaling - closed end function by customer or customer's end user
- C	C entrex Type Services foreign exchange termination
- M	For terminating in central office located answering service concentrator
IA -	E.I.A. (25 PIN RS-232)
LA -	End user loop start loop signaling - Type A OPS registered port open end
LB -	End user loop start loop signaling - Type B OPS registered port open end
LC -	End user loop start loop signaling - Type C OPS registered port open end
LO -	Loop start loop signaling - open end function by customer or customer's end user
LR -	20 Hz automatic ringdown interface at customer with Company provided PLAR
LS -	Loop start loop signaling - closed end function by customer or customer's end user
- M	For terminating in central office located answering service concentrator
NO -	No signaling interface, transmission only
PG -	Program transmission - no dc signaling
- 3	Nominal frequency from 200 to 3,500 Hz
- 5	Nominal frequency from 100 to 5,000 Hz
- 8	Nominal frequency from 50 to 8,000 Hz
PR -	Protective relaying ¹
RV - O	Reverse battery signaling, one way operation, originate by customer

Note 1: Available only for the transmission of audio tone protective relaying signals used in the protection of electric power systems during fault conditions.

PUBLIC SERVICE COMMISSION
OF KENTUCKY
EFFECTIVE

FEB 16 1997

PURSUANT TO 807 KAR 5:011,
SECTION 9 (1)

BY: Jordan C. Neal
FOR THE PUBLIC SERVICE COMMISSION

E7. SPECIAL ACCESS (A.K.A. BELLSOUTH SPA) SERVICE

E7.3 Channel Interface And Network Channel Codes (Cont'd)

E7.3.1 Glossary Of Channel Interface Codes And Options (Cont'd)

Code - Option	Definition	
- T	Reverse battery signaling, one way operation, terminate function by customer or customer's end user	
SF -	Single frequency signaling with VF band at either customer POT or customer's end user POT	
TF -	Telephotograph ¹ interface	(C)
TT -	Telegraph ¹ /teletypewriter interface at either customer POT or customer's end user POT	(C)
- 2	20.0 milliamperes	
TT - 3	3.0 milliamperes	
- 6	62.5 milliamperes	
	(DELETED)	
	(DELETED)	

Note 1: Effective June 30, 2021, this Service will no longer be available for purchase by new or existing customers. In addition, requests to move, add, change, or renew existing service arrangements will not be accepted. Following the expiration of a customer's existing term agreement, service will be provided on a month-to-month basis at the applicable Monthly rates until the service is discontinued. The Company currently plans to discontinue this service on or after June 30, 2024.

(N)
|
(N)



BELLSOUTH
 TELECOMMUNICATIONS, INC.
 KENTUCKY
 ISSUED: January 17, 1997
 BY: E.C. Roberts, Jr., President - KY
 Louisville, Kentucky

ACCESS SERVICES TARIFF

PSC KY. TARIFF 2E
 Third Revised Page 27
 Cancels Second Revised Page 27
 EFFECTIVE: February 16, 1997

E7. SPECIAL ACCESS (A.K.A. BELLSOUTH SPA) SERVICE

(T)

E7.3 Channel Interface And Network Channel Codes (Cont'd)

E7.3.2 Impedance

The nominal reference impedance with which the channel will be terminated for the purpose of evaluating transmission performance:

Value (ohms)	Code(s)
110	0
150	1
600	2
900	3
135	5
75	6
124	7
Variable	8
100	9

E7.3.3 Digital Hierarchy Channel Interface Codes (4DS)

Customers selecting the channelized four-wire DS-1 or higher facility interface option at the customer designated premises will be requested to provide subsequent system and channel assignment data. The various digital bit rates in the digital hierarchy employ the channel interface code 4DS9, 4DS0 or 4DS6 plus the speed options indicated following:

Interface Code and Speed Option	Nominal Bit Rate (Mbps)	Digital Hierarchy Level
4DS9-15	1.544	DS1
4DS9-31	3.152	DS1C
4DS0-63	6.312	DS2
4DS6-44	44.736	DS3

E7.3.4 Service Designator/Network Channel Code Conversion Table

The purpose of this table is to show the relationship between the service designator codes (e.g. VG1, MT2, etc.) and the network channel codes that are used for various administrative purposes.

Service Designator Code	Network Channel Code
MT1	NT
MT2	NU

PUBLIC SERVICE COMMISSION
 OF KENTUCKY
 EFFECTIVE

FEB 16 1997

PURSUANT TO 807 KAR 5:011,
 SECTION 9 (1)

BY: Jordan C. Neal
 FOR THE PUBLIC SERVICE COMMISSION

BELLSOUTH
TELECOMMUNICATIONS, INC.
KENTUCKY

ACCESS SERVICES TARIFF

PSC KY. TARIFF 2E
Third Revised Page 28
Cancels Second Revised Page 28
EFFECTIVE: February 16, 1997

ISSUED: January 17, 1997

BY: E.C. Roberts, Jr., President - KY
Louisville, Kentucky

E7. SPECIAL ACCESS (A.K.A. BELLSOUTH SPA) SERVICE

(1)

E7.3 Channel Interface And Network Channel Codes (Cont'd)

E7.3.4 Service Designator/Network Channel Code Conversion Table (Cont'd)

Service Designator Code	Network Channel Code
MT3	NV
TG1	NW
TG2	NY
VG1	LB
VG2	LC
VG3	LD
VG4	LE
VG5	LF
VG6	LG
VG7	LH
VG8	LJ
VG9	LK
VG10	LN
VG11	LP
VG12	LR
AP1	PE
AP2	PF
AP3	PJ
AP4	PK
TV3	TZ
DA1	XA
DA2	XB

PUBLIC SERVICE COMMISSION
OF KENTUCKY
EFFECTIVE

FEB 16 1997

PURSUANT TO 807 KAR 5.011,
SECTION 9 (1)

BY: Jordan C. Neal
FOR THE PUBLIC SERVICE COMMISSION

BELLSOUTH
TELECOMMUNICATIONS, INC.
KENTUCKY
ISSUED: January 17, 1997
BY: E.C. Roberts, Jr., President - KY
Louisville, Kentucky

ACCESS SERVICES TARIFF

PSC KY. TARIFF 2E
Third Revised Page 29
Cancels Second Revised Page 29
EFFECTIVE: February 16, 1997

E7. SPECIAL ACCESS (A.K.A. BELLSOUTH SPA) SERVICE

(T)

E7.3 Channel Interface And Network Channel Codes (Cont'd)

E7.3.4 Service Designator/Network Channel Code Conversion Table (Cont'd)

Service Designator Code	Network Channel Code
DA3	XG
DA4	XH
DA5	XE
DA6	YN
HC0	HS
HC1	HC
HC1C	HD
HC2	HE
HC3	HF

PUBLIC SERVICE COMMISSION
OF KENTUCKY
EFFECTIVE

FEB 16 1997

PURSUANT TO 807 KAR 5.011,
SECTION 9 (1)

BY: Jordan C. Neal
FOR THE PUBLIC SERVICE COMMISSION

BELLSOUTH
TELECOMMUNICATIONS, INC.
KENTUCKY

ACCESS SERVICES TARIFF

PSC KY. TARIFF 2E
Second Revised Page 30
Cancels First Revised Page 30
EFFECTIVE: February 16, 1997

ISSUED: January 17, 1997
BY: E.C. Roberts, Jr., President - KY
Louisville, Kentucky

E7. SPECIAL ACCESS (A.K.A. BELLSOUTH SPA) SERVICE

(T)

E7.3 Channel Interface And Network Channel Codes (Cont'd)

(T)

E7.3.5 Reserved For Future Use

PUBLIC SERVICE COMMISSION
OF KENTUCKY
EFFECTIVE

FEB 16 1997

PURSUANT TO 807 KAR 5.011,
SECTION 9 (1)

BY: *Jordan C. Neal*
FOR THE PUBLIC SERVICE COMMISSION

BELLSOUTH
TELECOMMUNICATIONS, INC.
KENTUCKY
ISSUED: January 17, 1997
BY: E.C. Roberts, Jr., President - KY
Louisville, Kentucky

ACCESS SERVICES TARIFF

PSC KY. TARIFF 2E
Second Revised Page 31
Cancels First Revised Page 31
EFFECTIVE: February 16, 1997

E7. SPECIAL ACCESS (A.K.A. BELLSOUTH SPA) SERVICE

(T)

E7.3 Channel Interface And Network Channel Codes (Cont'd)

E7.3.5 Reserved For Future Use

(T)

PUBLIC SERVICE COMMISSION
OF KENTUCKY
EFFECTIVE

FEB 16 1997

PURSUANT TO 807 KAR 5011,
SECTION 9 (1)

BY: Jordan C. Neal
FOR THE PUBLIC SERVICE COMMISSION

BELLSOUTH
TELECOMMUNICATIONS, INC.
KENTUCKY
ISSUED: January 17, 1997
BY: E.C. Roberts, Jr., President - KY
Louisville, Kentucky

ACCESS SERVICES TARIFF

PSC KY. TARIFF 2E
Second Revised Page 32
Cancels First Revised Page 32
EFFECTIVE: February 16, 1997

E7. SPECIAL ACCESS (A.K.A. BELLSOUTH SPA) SERVICE

(T)

E7.3 Channel Interface And Network Channel Codes (Cont'd)

E7.3.5 Reserved For Future Use

(T)

PUBLIC SERVICE COMMISSION
OF KENTUCKY
EFFECTIVE

FEB 16 1997

PURSUANT TO 807 KAR 5.011,
SECTION 9 (1)
BY: Jordan C. Neal
FOR THE PUBLIC SERVICE COMMISSION

BELLSOUTH
TELECOMMUNICATIONS, INC.

KENTUCKY

ISSUED: January 17, 1997

BY: E.C. Roberts, Jr., President - KY
Louisville, Kentucky

ACCESS SERVICES TARIFF

PSC KY. TARIFF 2E
Second Revised Page 33
Cancels First Revised Page 33
EFFECTIVE: February 16, 1997

E7. SPECIAL ACCESS (A.K.A. BELLSOUTH SPA) SERVICE

(T)

E7.3 Channel Interface And Network Channel Codes (Cont'd)

(T)

E7.3.5 Reserved For Future Use

PUBLIC SERVICE COMMISSION
OF KENTUCKY
EFFECTIVE

FEB 16 1997

PURSUANT TO 807 KAR 5.011,
SECTION 9 (1)

BY: Jordan C. Neal
FOR THE PUBLIC SERVICE COMMISSION

BELLSOUTH
TELECOMMUNICATIONS, INC.

KENTUCKY

ISSUED: January 17, 1997

BY: E.C. Roberts, Jr., President - KY
Louisville, Kentucky

ACCESS SERVICES TARIFF

PSC KY. TARIFF 2E

Second Revised Page 34

Cancels First Revised Page 34

EFFECTIVE: February 16, 1997

E7. SPECIAL ACCESS (A.K.A. BELLSOUTH SPA) SERVICE

(T)

E7.3 Channel Interface And Network Channel Codes (Cont'd)

E7.3.5 Reserved For Future Use

(T)

PUBLIC SERVICE COMMISSION
OF KENTUCKY
EFFECTIVE

FEB 16 1997

PURSUANT TO 807 KAR 5:011,
SECTION 9 (1)

BY: Jordan C. Neal
FOR THE PUBLIC SERVICE COMMISSION

BELLSOUTH
TELECOMMUNICATIONS, INC.
KENTUCKY
ISSUED: January 17, 1997
BY: E.C. Roberts, Jr., President - KY
Louisville, Kentucky

ACCESS SERVICES TARIFF

PSC KY. TARIFF 2E
Second Revised Page 35
Cancels First Revised Page 35
EFFECTIVE: February 16, 1997

E7. SPECIAL ACCESS (A.K.A. BELLSOUTH SPA) SERVICE

(T)

E7.3 Channel Interface And Network Channel Codes (Cont'd)

E7.3.5 Reserved For Future Use

(T)

PUBLIC SERVICE COMMISSION
OF KENTUCKY
EFFECTIVE

FEB 16 1997

PURSUANT TO 807 KAR 5.011,
SECTION 9 (1)

BY: Judith C. Neal
FOR THE PUBLIC SERVICE COMMISSION

BELLSOUTH
TELECOMMUNICATIONS, INC.
KENTUCKY
ISSUED: January 17, 1997
BY: E.C. Roberts, Jr., President - KY
Louisville, Kentucky

ACCESS SERVICES TARIFF

PSC KY. TARIFF 2E
Second Revised Page 36
Cancels First Revised Page 36
EFFECTIVE: February 16, 1997

E7. SPECIAL ACCESS (A.K.A. BELLSOUTH SPA) SERVICE

(T)

E7.3 Channel Interface And Network Channel Codes (Cont'd)

E7.3.5 Reserved For Future Use

(T)

PUBLIC SERVICE COMMISSION
OF KENTUCKY
EFFECTIVE

FEB 16 1997

PURSUANT TO 807 KAR 5.011,
SECTION 9 (1)

BY: Jordan C. Neal
FOR THE PUBLIC SERVICE COMMISSION

BELLSOUTH
TELECOMMUNICATIONS, INC.
KENTUCKY
ISSUED: January 17, 1997
BY: E.C. Roberts, Jr., President - KY
Louisville, Kentucky

ACCESS SERVICES TARIFF

PSC KY. TARIFF 2E
Second Revised Page 37
Cancels First Revised Page 37
EFFECTIVE: February 16, 1997

E7. SPECIAL ACCESS (A.K.A. BELLSOUTH SPA) SERVICE

(T)

E7.3 Channel Interface And Network Channel Codes (Cont'd)

E7.3.5 Reserved For Future Use

(T)

PUBLIC SERVICE COMMISSION
OF KENTUCKY
EFFECTIVE

FEB 16 1997

PURSUANT TO 807 KAR 5.011,
SECTION 9 (1)

BY: Jordan C. Neal
FOR THE PUBLIC SERVICE COMMISSION

BELLSOUTH
TELECOMMUNICATIONS, INC.
KENTUCKY
ISSUED: January 17, 1997
BY: E.C. Roberts, Jr., President - KY
Louisville, Kentucky

ACCESS SERVICES TARIFF

PSC KY. TARIFF 2E
Second Revised Page 38
Cancels First Revised Page 38
EFFECTIVE: February 16, 1997

E7. SPECIAL ACCESS (A.K.A. BELLSOUTH SPA) SERVICE

(T)

E7.3 Channel Interface And Network Channel Codes (Cont'd)

(T)

E7.3.5 Reserved For Future Use

PUBLIC SERVICE COMMISSION
OF KENTUCKY
EFFECTIVE

FEB 16 1997

PURSUANT TO 807 KAR 5.011,
SECTION 9 (1)

BY: *Jordan C. Neal*
FOR THE PUBLIC SERVICE COMMISSION

BELLSOUTH
TELECOMMUNICATIONS, INC.

KENTUCKY

ISSUED: January 17, 1997

BY: E.C. Roberts, Jr., President - KY
Louisville, Kentucky

ACCESS SERVICES TARIFF

PSC KY. TARIFF 2E

Second Revised Page 39

Cancels First Revised Page 39

EFFECTIVE: February 16, 1997

E7. SPECIAL ACCESS (A.K.A. BELLSOUTH SPA) SERVICE

(T)

E7.3 Channel Interface And Network Channel Codes (Cont'd)

E7.3.5 Reserved For Future Use

(T)

PUBLIC SERVICE COMMISSION
OF KENTUCKY
EFFECTIVE

FEB 16 1997

PURSUANT TO 807 KAR 5.011,
SECTION 9 (1)

BY: *Jordan C. Neal*
FOR THE PUBLIC SERVICE COMMISSION

BELLSOUTH
TELECOMMUNICATIONS, INC.
KENTUCKY

ACCESS SERVICES TARIFF

PSC KY. TARIFF 2E
Second Revised Page 40
Cancels First Revised Page 40
EFFECTIVE: February 16, 1997

ISSUED: January 17, 1997

BY: E.C. Roberts, Jr., President - KY
Louisville, Kentucky

E7. SPECIAL ACCESS (A.K.A. BELLSOUTH SPA) SERVICE

(T)

E7.3 Channel Interface And Network Channel Codes (Cont'd)

E7.3.5 Reserved For Future Use

(T)

PUBLIC SERVICE COMMISSION
OF KENTUCKY
EFFECTIVE

FEB 16 1997

PURSUANT TO 807 KAR 5:011,
SECTION 9 (1)

BY: Jordan C. Neal
FOR THE PUBLIC SERVICE COMMISSION

BELLSOUTH
TELECOMMUNICATIONS, INC.
KENTUCKY
ISSUED: January 17, 1997
BY: E.C. Roberts, Jr., President - KY
Louisville, Kentucky

ACCESS SERVICES TARIFF

PSC KY. TARIFF 2E
Second Revised Page 41
Cancels First Revised Page 41
EFFECTIVE: February 16, 1997

E7. SPECIAL ACCESS (A.K.A. BELLSOUTH SPA) SERVICE

(T)

E7.3 Channel Interface And Network Channel Codes (Cont'd)

E7.3.5 Reserved For Future Use

(T)

PUBLIC SERVICE COMMISSION
OF KENTUCKY
EFFECTIVE

FEB 16 1997

PURSUANT TO 807 KAR 5.011,
SECTION 9 (1)

BY: *Jordan C. Neal*
FOR THE PUBLIC SERVICE COMMISSION

BELLSOUTH
TELECOMMUNICATIONS, INC.
KENTUCKY
ISSUED: January 17, 1997
BY: E.C. Roberts, Jr., President - KY
Louisville, Kentucky

ACCESS SERVICES TARIFF

PSC KY. TARIFF 2E
Second Revised Page 42
Cancels First Revised Page 42
EFFECTIVE: February 16, 1997

E7. SPECIAL ACCESS (A.K.A. BELLSOUTH SPA) SERVICE

(T)

E7.3 Channel Interface And Network Channel Codes (Cont'd)

(T)

E7.3.5 Reserved For Future Use

PUBLIC SERVICE COMMISSION
OF KENTUCKY
EFFECTIVE

FEB 16 1997

PURSUANT TO 807 KAR 5.011,
SECTION 9 (1)

BY: *Jonathan C. Neal*
FOR THE PUBLIC SERVICE COMMISSION

BELLSOUTH
TELECOMMUNICATIONS, INC.

ACCESS SERVICES TARIFF

PSC KY. TARIFF 2E
Second Revised Page 43
Cancels First Revised Page 43
EFFECTIVE: February 16, 1997

KENTUCKY
ISSUED: January 17, 1997
BY: E.C. Roberts, Jr., President - KY
Louisville, Kentucky

E7. SPECIAL ACCESS (A.K.A. BELLSOUTH SPA) SERVICE

(T)

E7.3 Channel Interface And Network Channel Codes (Cont'd)

E7.3.5 Reserved For Future Use

(T)

PUBLIC SERVICE COMMISSION
OF KENTUCKY
EFFECTIVE

FEB 16 1997

PURSUANT TO 807 KAR 5011,
SECTION 9 (1)

BY: Jordan C. Neal
FOR THE PUBLIC SERVICE COMMISSION

BELLSOUTH
TELECOMMUNICATIONS, INC.
KENTUCKY

ACCESS SERVICES TARIFF

PSC KY. TARIFF 2E
Second Revised Page 44
Cancels First Revised Page 44
EFFECTIVE: February 16, 1997

ISSUED: January 17, 1997
BY: E.C. Roberts, Jr., President - KY
Louisville, Kentucky

E7. SPECIAL ACCESS (A.K.A. BELLSOUTH SPA) SERVICE

(T)

E7.3 Channel Interface And Network Channel Codes (Cont'd)

E7.3.5 Reserved For Future Use

(T)

PUBLIC SERVICE COMMISSION
OF KENTUCKY
EFFECTIVE

FEB 16 1997

PURSUANT TO 807 KAR 5011,
SECTION 9 (1)

BY: Jordan C. Neal
FOR THE PUBLIC SERVICE COMMISSION

BELLSOUTH
TELECOMMUNICATIONS, INC.
KENTUCKY

ACCESS SERVICES TARIFF

PSC KY. TARIFF 2E
Second Revised Page 45
Cancels First Revised Page 45
EFFECTIVE: February 16, 1997

ISSUED: January 17, 1997
BY: E.C. Roberts, Jr., President - KY
Louisville, Kentucky

E7. SPECIAL ACCESS (A.K.A. BELLSOUTH SPA) SERVICE

(T)

E7.3 Channel Interface And Network Channel Codes (Cont'd)

(T)

E7.3.5 Reserved For Future Use

PUBLIC SERVICE COMMISSION
OF KENTUCKY
EFFECTIVE

FEB 16 1997

PURSUANT TO 807 KAR 5011,
SECTION 9 (1)

BY: Jordan C. Neel
FOR THE PUBLIC SERVICE COMMISSION

BELLSOUTH
TELECOMMUNICATIONS, INC.
KENTUCKY
ISSUED: January 17, 1997
BY: E.C. Roberts, Jr., President - KY
Louisville, Kentucky

ACCESS SERVICES TARIFF

PSC KY. TARIFF 2E
Second Revised Page 46
Cancels First Revised Page 46
EFFECTIVE: February 16, 1997

E7. SPECIAL ACCESS (A.K.A. BELLSOUTH SPA) SERVICE (T)

E7.3 Channel Interface And Network Channel Codes (Cont'd) (T)

E7.3.5 Reserved For Future Use

PUBLIC SERVICE COMMISSION
OF KENTUCKY
EFFECTIVE

FEB 16 1997

PURSUANT TO 807 KAR 5.011,
SECTION 9 (1)

BY: Jordan C. Neal
FOR THE PUBLIC SERVICE COMMISSION

BELLSOUTH
TELECOMMUNICATIONS, INC.

ACCESS SERVICES TARIFF

PSC KY. TARIFF 2E
Second Revised Page 47
Cancels First Revised Page 47
EFFECTIVE: February 16, 1997

KENTUCKY
ISSUED: January 17, 1997
BY: E.C. Roberts, Jr., President - KY
Louisville, Kentucky

E7. SPECIAL ACCESS (A.K.A. BELLSOUTH SPA) SERVICE

(T)

E7.3 Channel Interface And Network Channel Codes (Cont'd)

E7.3.5 Reserved For Future Use

(T)

PUBLIC SERVICE COMMISSION
OF KENTUCKY
EFFECTIVE

FEB 16 1997

PURSUANT TO 807 KAR 5.011,
SECTION 9 (1)

BY: Jordan C. Neal
FOR THE PUBLIC SERVICE COMMISSION

BELLSOUTH
TELECOMMUNICATIONS, INC.
KENTUCKY

ACCESS SERVICES TARIFF

PSC KY. TARIFF 2E
Second Revised Page 48
Cancels First Revised Page 48
EFFECTIVE: February 16, 1997

ISSUED: January 17, 1997
BY: E.C. Roberts, Jr., President - KY
Louisville, Kentucky

E7. SPECIAL ACCESS (A.K.A. BELLSOUTH SPA) SERVICE

(T)

E7.3 Channel Interface And Network Channel Codes (Cont'd)

E7.3.5 Reserved For Future Use

(T)

PUBLIC SERVICE COMMISSION
OF KENTUCKY
EFFECTIVE

FEB 16 1997

PURSUANT TO 807 KAR 5.011,
SECTION 9 (1)

BY: Jordan C. Neal
FOR THE PUBLIC SERVICE COMMISSION