

COMMONWEALTH OF KENTUCKY
BEFORE THE PUBLIC SERVICE COMMISSION

In the Matter of:

STEVE RICKETTS)	
)	
COMPLAINANT)	
)	CASE NO.
V.)	2021-00182
)	
LOUISVILLE GAS & ELECTRIC COMPANY)	
)	
DEFENDANT)	

ORDER

Louisville Gas & Electric Company (LG&E) is hereby notified that it has been named as a Defendant in a formal complaint filed on April 23, 2021, a copy of which is attached to this Order.

Pursuant to 807 KAR 5:001, Section 20, LG&E is HEREBY ORDERED to satisfy the matters complained of or file a written answer to the complaint within ten days from the date of entry of this Order.

The Commission directs the parties to the March 16, 2020 and March 24, 2020 Orders in Case No. 2020-00085¹ regarding the filing of physical documents with the Commission. In the March 16, 2020 Order, the Commission stated that if a nonelectronic case is not converted to an electronic case, the Commission will grant a deviation from the filing requirements 807 KAR 5:001, Section 7(1), insofar that a filer may file one

¹ Case No. 2020-00085, *Electronic Emergency Docket Related to the Novel Coronavirus COVID-19* (Ky. PSC Mar. 16, 2020), Order at 5–6. Case No. 2020-00085, *Electronic Emergency Docket Related to the Novel Coronavirus COVID-19* (Ky. PSC Mar. 24, 2020), Order at 1–3.

original document with no copies, or send an electronic mail message with an electronic copy of the document to the Commission and to parties to the matter. The Commission expects that original documents will be filed with the Commission within 30 days of the lifting of the current state of emergency. Any electronic email filed in this manner should be sent to PSCED@ky.gov, and each message should include the case number in the subject line of the message and a read receipt to ensure the Commission received the message and documents.² A party filing a paper containing personal information shall, in accordance with 807 KAR 5:001, Section 4(10), encrypt or redact the paper so that personal information cannot be read.

[REMAINDER OF PAGE INTENTIONALL LEFT BLANK]

² Any electronic email filed in this matter should be sent to PSCED@ky.gov, and each message should include the case number in the subject line of the message and a read receipt to ensure the Commission received the message and documents.

By the Commission



ATTEST:

Executive Director

ATTACHMENT

ATTACHMENT TO AN ORDER OF THE KENTUCKY PUBLIC SERVICE
COMMISSION IN CASE NO. 2021-00182 DATED JUL 02 2021

SIXTY-FIVE PAGES TO FOLLOW

RECEIVED

APR 23 2021

PUBLIC SERVICE
COMMISSION

COMMONWEALTH OF KENTUCKY
BEFORE THE PUBLIC SERVICE COMMISSION
CASE NO. 2021-00182

STEVE RICKETTS

COMPLAINANT

V.

LOUISVILLE GAS & ELECTRIC COMPANY

DEFENDANT

FORMAL COMPLAINT

Comes now the Complainant, Steve Ricketts (“Ricketts”), by and through counsel, pursuant to 807 KAR 5:001 Section 20, and for his Formal Complaint against Louisville Gas & Electric Company (“LG&E”), state as follows.

PARTIES

1. Ricketts lives in Louisville, Kentucky, and is an LG&E customer. His mailing address is 214 Kennedy Avenue, Louisville, Kentucky 40206. He is the Co-owner and General Manager of Solar Energy Solutions, Inc. (“SES”), a Kentucky solar company that installs solar facilities across the state. He is also an SES client. Ricketts is an existing customer generator taking service under LG&E’s NMS rider, and currently has a 10.02 kW DC solar generating facility at his residence, same address as above, with battery storage. The battery power rating is 7.6 kW AC and 9.8 kWh.
2. Defendant LG&E is a public utility engaged in the electric and gas business, and its rates and service to Mr. Ricketts are subject to the jurisdiction of the Kentucky Public Service Commission. LG&E generates and purchases electricity, and distributes and sells electricity at retail in Jefferson County and portions of Bullitt, Hardin, Henry, Meade, Oldham, Shelby, Spencer, and Trimble Counties. LG&E also purchases, stores, and transports natural gas and distributes and sells natural gas at retail in Jefferson County

and portions of Barren, Bullitt, Green, Hardin, Hart, Henry, Larue, Marion, Meade, Metcalfe, Nelson, Oldham, Shelby, Spencer, Trimble, and Washington Counties. LG&E is also proposing a new net metering rider in KY PSC Case No. 2020-0350 currently pending with the Commission. LG&E is located at 220 West Main Street, Louisville, Kentucky 40202, with a mailing address of P.O. Box 32010, 220 West Main Street, Louisville, Kentucky 40202.

FACTUAL BACKGROUND

LG&E's Customer Notices

3. On January 12, 2021, LG&E filed with the Commission a Certificate of Completed Notice ("Certificate"), in Commission Case No. 2020-00350.¹

4. In that Certificate, an LG&E representative certified that:

[T]here was delivered to the Kentucky Press Association, Inc. ("Kentucky Press"), an agency that acts on behalf of newspapers of general circulation throughout the Commonwealth of Kentucky in which customers affected reside, for publication therein once a week for three consecutive weeks beginning November 18, 2020, an abbreviated notice in conformity with the Commission's Order of November 10, 2020 in this proceeding of the filing of LG&E's Application. Publication of this notice is now complete. An affidavit from the Kentucky Press confirming this publication and a copy of said notice are attached as Exhibit A.²

5. Exhibit A of the Certificate contains Attachment No. 1, which includes a "[l]ist of newspapers running the Notice to Louisville Gas and Electric Company." The list contained seventeen newspapers in LG&E's service territory including the Louisville Courier-Journal, the local newspaper where Ricketts resides.³

¹ **Exhibit 1**; Certificate.

² **Exhibit 1**; Certificate at 1.

³ **Exhibit 1**; Certificate, Attachment No. 1.

6. Exhibit A also contains Attachment No. 2, the Customer Notice of Rate Adjustment. On page 3 of the Customer Notice of Rate Adjustment (“Customer Notice”), it states, in pertinent part:

LG&E is proposing a new net metering rate schedule, Rider NMS-2, and renaming its existing Rider NMS to be Rider NMS-1. Rider NMS-1 will serve eligible electric generating facilities as defined in KRS 278.465(2) for which customers have submitted an application for net metering service before the effective date of rates established in this proceeding. Rider NMS-2 will apply to all other net metering customers. LG&E is also proposing new terms and conditions for Net Metering Service Interconnection Guidelines.

(Emphasis added).⁴

7. The Certificate further certifies that:

[B]eginning on the 18th day of November 2020, LG&E posted on its website a copy of the more detailed and lengthy notice that 807 KAR 5:001, Section 17 requires and a hyperlink to the location on the Commission’s website where the case documents and tariff filings are available. Beginning on the 25th day of November 2020, LG&E posted on its website a complete copy of LG&E’s application in this case. Both the notice being published in newspapers and the bill inserts being sent to customers include the web address to the online posting.⁵

8. The webpage linked to the hyperlink contains an abbreviated newspaper notice that appears to be the same Customer Notice of Rate Adjustment contained in the Certificate at Exhibit A, Attachment 2, with identical language, as follows:

LG&E is proposing a new net metering rate schedule, Rider NMS-2, and renaming its existing Rider NMS to be Rider NMS-1. Rider NMS-1 will serve eligible electric generating facilities as defined in KRS 278.465(2) for which customers have submitted an application for net metering service before the effective date of rates established in this proceeding. Rider NMS-2 will apply to all

⁴ **Exhibit 1**; Certificate, Attachment No. 2, at 3.

⁵ **Exhibit 1**; Certificate at 2. That hyperlink is: <https://lge-u.com/regulatory/2020/electronic-application-LGE-adjustment-electric-gas-rates>, last visited April 20, 2021.

other net metering customers. LG&E is also proposing new terms and conditions for Net Metering Service Interconnection Guidelines.

(Emphasis added).⁶

9. The Certificate also certifies that “LG&E’s Application filed with the Commission on the 25th day of November 2020, includes the customer notice as a separate document labeled ‘Customer Notice of Rate Adjustment.’”⁷ That Notice also appears to be the same Customer Notice of Rate Adjustment contained in the Certificate at Exhibit A, Attachment 2, with identical language, as follows:

LG&E is proposing a new net metering rate schedule, Rider NMS-2, and renaming its existing Rider NMS to be Rider NMS-1. Rider NMS-1 will serve eligible electric generating facilities as defined in KRS 278.465(2) for which customers have submitted an application for net metering service before the effective date of rates established in this proceeding. Rider NMS-2 will apply to all other net metering customers. LG&E is also proposing new terms and conditions for Net Metering Service Interconnection Guidelines.

(Emphasis added).⁸

10. Thus, in three separate documents referenced in the Certificate, prepared by Defendant LG&E, required to support its rate adjustment application, and caused by the Defendant to be published in seventeen different newspapers, once a week for three weeks in November 2020, the Customer Notice of Rate Adjustment contained language stating, “Rider NMS-1 will serve eligible electric generating facilities as defined in KRS

⁶ **Exhibit 2**, Abbreviated Newspaper Notice at 3.

⁷ **Exhibit 1**; Certificate at 2.

⁸ **Exhibit 3**; Customer Notice of Rate of Adjustment filed on November 25, 2020 in Case No. 2020-00350.

278.465(2) for which customers have submitted an application for net metering service before the effective date of rates established in this proceeding.”

Ricketts Interconnection Application

11. In reliance upon the Customer Notices of Rate Adjustment, Ricketts decided to expand his solar generating facility and file his interconnection application to take service under NMS or the proposed NMS 1 before the effective date of any new rates established in LG&E’s ongoing rate case.
12. On April 8, 2021, Clayton Salchi, an engineer at SES and on behalf of Ricketts, submitted a Level 1 Interconnection Application, pursuant to the Interconnection and Net Metering Guidelines – Kentucky (“Interconnection Guidelines”),⁹ with LG&E to interconnect an expansion to Ricketts’ current solar generating facility. The application calls for the installation of additional solar panel modules and a new inverter to add 4.44 kW DC and 3.80 kW AC to his existing system for a total inverter power rating of 11.40 kW AC, a permissible expansion under Kentucky’s net metering law. Ricketts also stated his expected start-up date to be October 31, 2021.¹⁰
13. On April 19, 2021, LG&E approved the Ricketts Application.¹¹
14. On April 19, 2021, Salchi responded to the email sent by Timothy Melton, LG&E/KU Manager of Customer Commitment (“Melton”), approving the Rickett’s Application to ask, “To confirm, LG&E will honor the customer’s expansion in Q3 under current net

⁹ Available at <https://www.psc.ky.gov/agencies/psc/Industry/Electric/Final%20Net%20Metering-Interconnection%20Guidelines%201-8-09.pdf>, last visited April 21, 2021.

¹⁰ **Exhibit 4**, Ricketts Application and **Exhibit 5**, April 8, 2021 Email from Salchi to Melton.

¹¹ **Exhibit 5**; April 19, 2021, 10:20 am, Email from Melton to Salchi.

metering guidelines?”¹² Melton, an agent of Defendant LG&E authorized to address the subject, responded:

If this installation is completed in Q3, the whole net metering (old and new) would be under the new guidelines. Everything must be installed and operational prior to effective change date. Customer can do maintenance on existing panels (replacing a bad panel) or add batteries after the effective date and not lose grandfathering.¹³

CLAIM I

LG&E IS UNLAWFULLY DIVESTING RICKETTS OF HIS NET METERING LEGACY RIGHTS

15. The above numbered paragraphs are incorporated herein as if fully set out below.
16. Mr. Ricketts is currently taking service under a Commission approved net metering tariff rider. Pursuant to KRS 278.466(6) vests Mr. Ricketts with certain rights to continue to receive service under LG&E’s existing net metering tariff for a term of no less than 25 years.
17. LG&E claims that the already approved expansion of Ricketts’ “whole net metering (old and new) would be under the new guidelines” and, further, that the Customer can only “do maintenance on existing panels (replacing a bad panel) or add batteries after the effective date and not lose grandfathering.”¹⁴
18. LG&E’s position is not based upon language in its current Commission approved net metering tariff rider but is instead based upon LG&E’s proposed net metering tariff framework that is currently suspended pending investigation by the Commission in KY PSC Case No. 2020-00350 and which has not been approved by the Commission for use by LG&E.

¹² **Exhibit 5**; April 19, 2021, 1:02 pm, Email from Salchi to Melton.

¹³ **Exhibit 5**; April 19, 2021, 2:02 pm, Email from Melton to Salchi

¹⁴ **Exhibit 5**; April 19, 2021, 2:02 pm, Email from Melton to Salchi.

19. By not allowing Ricketts to maintain his legacy rights when enlarging his existing system while still being under the 45 kW statutory limitation, LG&E is effectively and unlawfully imposing a “material change” test to divest eligible electric generating facilities from legacy rights created by SB 100, (2019 Ky. Acts Ch. 101) and set forth by KRS 278.466(6). No such test exists under KRS 278.466(6). Further, no such test for divestment of legacy rights has received Commission approval for use by LG&E.
20. While net metering customers have interconnection responsibilities and limitations concerning repair, replacement, and modification, pursuant to the Interconnection Guidelines, those interconnection matters do not allow for the termination of the legacy rights created pursuant to KRS 278.466(6).
21. The Commission should expressly reject and deny LG&E’s “material change” test for divesting legacy rights created pursuant to KRS 278.466(6). The “material change” test has not been established by the Legislature, and its implementation by LG&E would run directly contrary to and frustrate the intent for KRS 278.466(6).
22. LG&E’s actions are unjust, unreasonable, unsafe, improper, inadequate and insufficient, as LG&E has not acted in accordance with KRS 278.466 with regards to legacy rights.
23. LG&E’s actions are furthermore unjust, unreasonable, unsafe, improper, inadequate and insufficient in that they are not based upon an existing Commission approved tariff but rather upon a proposed, yet to be approved, LG&E tariff.
24. The Commission should order LG&E to allow Ricketts and other customers seeking to expand their generating facilities to maintain their legacy rights pursuant to KRS 278.466(6) as long as that system does not exceed the statutory 45 kW system size limit.

CLAIM II

LG&E SHOULD BE PROHIBITED FROM ANY ACTION THAT IS CONTRARY TO ADVERTISED CUSTOMER NOTICE

25. The above numbered paragraphs are incorporated herein as if fully set out below.
26. Relying on the Customer Notices advertised and filed by LG&E, Ricketts submitted a Level 1 Interconnection Application on April 9, 2021, prior to the effective date of any new rates in Case No. 2020-00350 to expand his solar generating facility consistent with the Customer Notices. His intention was to take service under LG&E's current NMS rider or the proposed NMS 1 rider as advertised and noticed by LG&E.
27. Instead, LG&E denied Ricketts such service and responded, "If this installation is completed in Q3, the whole net metering (old and new) would be under the new guidelines." This is in direct contradiction to the Customer Notice.
28. On this point, there is no demonstration that the LG&E Customer Notice suffers from a typographical error or is in any way ambiguous. Further, as is the nature of such required notices, it is a material representation by LG&E.
29. LG&E's actions are unjust, unreasonable, unsafe, improper, inadequate and insufficient, as LG&E has not acted in accordance with its own advertised and filed Customer Notices, and in the least, has materially misled the public and its customers regarding the conditions of that notice.
30. The Commission should require LG&E to abide by the conditions of its own Customer Notice for all customers, including Ricketts, that have acted upon the Customer Notice in reliance of that Notice.
31. Additionally and/or alternatively, the Commission should, until such time that the proposed tariff provisions have been properly notice and approved by the Commission,

deny and reject the use of the proposed net metering tariff practices because (1) they are not yet authorized; (2) they are materially different from the descriptions in the various notices; and (3) they are contrary to statute.

CLAIM III

THE COMMISSION SHOULD DETERMINE THAT THE INTERCONNECTION APPLICATION DATE SERVE'S AS THE IN SERVICE DATE FOR MR. RICKETTS AND SIMILARLY SITUATED NET METER SERVICE CUSTOMERS AND APPROVED APPLICANTS

32. The above numbered paragraphs are incorporated herein as if fully set out below.
33. In addition to the Customer Notice language, the Commission should permit the Interconnection Application submission date to serve as the “in service” date for purposes of retaining legacy rights as contemplated by KRS 278.466(6) and for determining the effective net metering tariff.
34. The lack of certainty regarding the effective date of a new net metering tariff in response to SB 100 and the timing of utility and local government approval, construction, and start-up of a new generating facility is leaving potential and existing customer generators, including Ricketts, in a precarious position with no just, reasonable, proper, adequate or sufficient way of determining what the costs and compensation rate may be over the warranted life of a generating facility. Mr. Ricketts and similarly situation customers and applicants for net metering service are entitled to take action under and rely upon the existing approved net metering service tariff and not be subjected to practices that are merely proposed, unapproved, and which may remain unapproved.
35. The Commission should find and conclude, consistent with LG&E’s material representation in its notices, that the Interconnection Application submission date serves as the “in service” date for purposes of retaining legacy rights and determining the

effective net metering tariff that applies under LG&E's proposed net metering tariff framework, if and when otherwise approved.

CLAIM IV

RICKETTS ESTABLISHES A *PRIMA FACIE* CASE

36. The above numbered paragraphs are incorporated herein as if fully set out below.
37. 807 KAR 5:001, Section 20(4)(a), requires that the Commission examine and determine whether the complaint establishes a *prima facie* case. A complaint establishes a *prima facie* case when, on its face, it states sufficient allegations that, if not contradicted by other evidence, would entitle the complainant to the requested relief.¹⁵
38. Ricketts is an LG&E customer currently taking service pursuant to LG&E's net metering rider. He has requested that LG&E interconnect his expanded solar generating facility. While approving the application, LG&E has asserted that it will divest Ricketts of all of his statutory legacy rights despite Ricketts filing his application before a new tariff is approved and despite the Customer Notice stating otherwise. Ricketts has standing to assert these claims, the claims are ripe for review, and Ricketts has stated sufficient allegations would entitle him to the requested relief. Prohibiting and remedying unfair, unjust, and unreasonable practices, such as the material misrepresentation in the customer notice, actions contrary to approved tariffs and statute, and the implementation of proposed practices prior to Commission approval, is squarely within the Commission's jurisdiction over Defendant LG&E's rates and service.

WHEREFORE, the Complainant respectfully requests the following relief:

¹⁵ Case No. 2010-00404, *Bulldog's Enterprises, Inc. d/b/a Bulldog's Road House v. Duke Energy Kentucky, Inc.* (Ky. PSC Nov 15, 2010).

1. The Commission find and conclude that Ricketts has established a *prima facie* case;
2. In the event that Defendant LG&E fails to satisfy Mr. Ricketts' Complaint, that the Commission find and conclude by Order that Ricketts and other similarly situated customer generators seeking to expand their generating facilities to maintain their legacy rights as long as that system does not exceed the statutory 45 kW system size limit;
3. An Order from the Commission requiring LG&E to abide by the conditions of its own Customer Notice for all customers, including Ricketts, that have acted upon the Customer Notice in reliance of that Customer Notice;
4. An Order from the Commission confirming that the Interconnection Application submission date serves as the "in service" date for purposes of retaining legacy rights and determining the effective net metering tariff that applies; and
5. All other relief that Complainant is entitled.

Respectfully submitted,



Randal A. Strobo, KBA #92767
David E. Spenard, KBA #84035
Strobo Barkley PLLC
239 South Fifth Street, Suite 917
Louisville, Kentucky 40202
(502) 290-9751
rstrobo@strobobarkley.com
dspenard@strobobarkley.com

*Counsel for Complainant
Steve Ricketts*

EXHIBIT 1

COMMONWEALTH OF KENTUCKY
BEFORE THE PUBLIC SERVICE COMMISSION

In the Matter of:

ELECTRONIC APPLICATION OF)	
LOUISVILLE GAS AND ELECTRIC)	
COMPANY FOR AN ADJUSTMENT OF ITS)	
ELECTRIC AND GAS RATES, A)	
CERTIFICATE OF PUBLIC CONVENIENCE)	CASE NO. 2020-00350
AND NECESSITY TO DEPLOY ADVANCED)	
METERING INFRASTRUCTURE,)	
APPROVAL OF CERTAIN REGULATORY)	
AND ACCOUNTING TREATMENTS, AND)	
ESTABLISHMENT OF A ONE-YEAR)	
SURCREDIT)	

CERTIFICATE OF COMPLETED NOTICE

Pursuant to the Kentucky Public Service Commission’s Regulation 807 KAR 5:001, Section 16(1)(b)(5), I hereby certify that I am Robert M. Conroy, Vice President, State Regulation and Rates, for Louisville Gas and Electric Company (“LG&E” or “Company”), a utility furnishing retail electric and gas service within the Commonwealth of Kentucky which, on the 25th day of November 2020, filed an application with the Kentucky Public Service Commission (“Commission”) for the approval of an adjustment of the electric and gas rates, terms, conditions and tariffs of LG&E, and that notice to the public of the filing of the application has been completed in all respects as required by the Commission’s Order of November 10, 2020 in this proceeding as follows:

I certify that more than twenty (20) customers will be affected by said change by way of an increase in their rates or charges, and that on the 10th day of November 2020, there was delivered to the Kentucky Press Association, Inc. (“Kentucky Press”), an agency that acts on behalf of newspapers of general circulation throughout the Commonwealth of Kentucky in which customers affected reside, for publication therein once a week for three consecutive weeks

beginning November 18, 2020, an abbreviated notice in conformity with the Commission’s Order of November 10, 2020 in this proceeding of the filing of LG&E’s Application. Publication of this notice is now complete. An affidavit from the Kentucky Press confirming this publication and a copy of said notice are attached as Exhibit A. The Kentucky Press has presented to LG&E proof of this publication of notice in the form of “tear sheets,” which LG&E will maintain in its files.

I further certify that on the 25th day of November 2020 the notice to the public was delivered for exhibition and public inspection at 820 West Broadway, Louisville, KY 40202 and that the same will be kept open to public inspection at said offices and places of business.

I further certify that, beginning on the 30th day November 2020, LG&E began including a general statement explaining the application in this case with the bills for all Kentucky retail customers during the course of their regular monthly billing cycle. An accurate copy of this general statement is attached as Exhibit B.

I further certify that, beginning on the 18th day of November 2020, LG&E posted on its website a copy of the more detailed and lengthy notice that 807 KAR 5:001, Section 17 requires and a hyperlink to the location on the Commission’s website where the case documents and tariff filings are available. Beginning on the 25th day of November 2020, LG&E posted on its website a complete copy of LG&E’s application in this case. Both the notice being published in newspapers and the bill inserts being sent to customers include the web address to the online posting. LG&E’s Application filed with the Commission on the 25th day of November 2020, includes the customer notice as a separate document labeled “Customer Notice of Rate Adjustment.”

In addition, beginning on the 13th day of November 2020, LG&E issued press advisories to all known news media organizations who cover the areas within its certified territory advising

of the filing of its application and including a hyperlink to the location on LG&E's and the Commission's websites where case documents and tariff filings will be available.

Given under my hand this 12th day of January 2021.

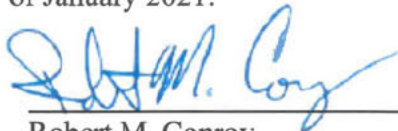

Robert M. Conroy
Vice President, State Regulation and Rates
LG&E and LG&E Services Company
220 West Main Street
Louisville, Kentucky 40202

Subscribed and sworn to before me, a Notary Public in and before said County and State,
this 12th day of January 2021.



Notary Public (SEAL)

Notary No.: 603967

My Commission Expires: 7/11/2022

CERTIFICATE OF COMPLIANCE

In accordance with 807 KAR 5:001 Section 8(7), this is to certify that Louisville Gas and Electric Company's January 12, 2021 electronic filing is a true and accurate copy of the documents being filed in paper medium; that the electronic filing has been transmitted to the Commission on January 12, 2021; that there are currently no parties that the Commission has excused from participation by electronic means in this proceeding; and that a true and correct copy in paper medium will be delivered to the Commission within 30 days of the lifting of the State of Emergency.



Gerald R. Riess
Counsel for Louisville Gas and Electric Company

Exhibit A

NOTARIZED PROOF OF PUBLICATION

COMMONWEALTH OF KENTUCKY

COUNTY OF Franklin

Before me, a Notary Public, in and for said county and state, this 15th day of December, 2020, came Rachel McCarty, personally known to me, who, being duly sworn, states as follows: that she is the Advertising Assistant of the Kentucky Press Service, Inc.; that she has personal knowledge of the contents of this Affidavit; that the newspapers shown on Attachment No. 1 to this Affidavit published the Abbreviated Customer Notice of Rate Adjustment for electric and gas rates on the dates shown thereon at the request of Kentucky Press Service, Inc. for Louisville Gas and Electric Company; that the form and content of the Notice submitted for publication to each paper is shown in Attachment No. 2 to this Affidavit; and that the Kentucky Press Service, Inc. has presented to Louisville Gas and Electric Company proof of these publications in the form of "tear sheets" for retention in its files. Said Notice pertains to the Application and proposed Tariffs filed by Louisville Gas and Electric Company with the Kentucky Public Service Commission in Case No. 2020-00350.

Rachel McCarty
Signature

Bonnie J. Howard
Notary Public
My Commission Expires: 9-18-2024
Id. # 14119
(SEAL)

[Attachments: (1) List of publications and dates of publication; (2) sample published notice]

Attachment No. 1

KENTUCKY PRESS SERVICE

101 Consumer Lane
(502) 223-8821

Frankfort, KY 40601
FAX (502) 875-2624

Rachel McCarty Advertising Dept.

List of newspapers running the Notice to Louisville Gas and Electric Company. Attached tearsheets provide proof of publication:

Bardstown KY Standard 11-18, 11-25, 12-2
Bedford Trimble Banner 11-19, 11-26, 12-3
Brandenburg Meade Co. Messenger 11-19, 11-26, 12-3
Cave City Barren Co Progress 11-19, 11-26, 12-3
Edmonton Herald News 11-18, 11-25, 12-2
Elizabethtown News Enterprise 11-18, 11-25, 12-2
Greensburg Record Herald 11-18, 11-25, 12-2
Hodgenville Larue Co Herald News 11-18, 11-25, 12-2
Lagrange Oldham Era 11-19, 11-26, 12-3
Lebanon Enterprise 11-18, 11-25, 12-2
Louisville Courier Journal 11-18, 11-25, 12-2
Munfordville Hart Co News Herald 11-19, 11-26, 12-3
New Castle Henry Co Local 11-18, 11-25, 12-2
Shelbyville Sentinel News 11-18, 11-25, 12-2
Shepherdsville Pioneer News 11-18, 11-25, 12-2
Springfield Sun 11-18, 11-25, 12-2
Taylorsville Spencer Magnet 11-18, 11-25, 12-2

Attachment No. 2

CUSTOMER NOTICE OF RATE ADJUSTMENT

PLEASE TAKE NOTICE that, in a November 25, 2020, Application, Louisville Gas and Electric Company (“LG&E”) is seeking approval by the Kentucky Public Service Commission of an adjustment of its electric and gas rates and charges to become effective on and after January 1, 2021.

LG&E CURRENT AND PROPOSED RESIDENTIAL ELECTRIC AND GAS RATES

Residential Service - Rate RS

	<u>Current</u>	<u>Proposed</u>
Basic Service Charge per Day:	\$ 0.45	\$ 0.52
Plus an Energy Charge per kWh:		
Infrastructure:	\$ 0.06072	\$ 0.07237
Variable:	\$ 0.03206	\$ 0.03245
Total:	\$ 0.09278	\$ 0.10482

Residential Time-of-Day Energy Service - Rate RTOD-Energy

	<u>Current</u>	<u>Proposed</u>
Basic Service Charge per Day:	\$ 0.45	\$ 0.52
Plus an Energy Charge per kWh:		
Off-Peak Hours (Infrastructure):	\$ 0.03874	\$ 0.04935
Off-Peak Hours (Variable):	\$ 0.03206	\$ 0.03245
Off-Peak Hours (Total):	\$ 0.07080	\$ 0.08180
On-Peak Hours (Infrastructure):	\$ 0.17302	\$ 0.14704
On-Peak Hours (Variable):	\$ 0.03206	\$ 0.03245
On-Peak Hours (Total):	\$ 0.20508	\$ 0.17949

Residential Time-of-Day Demand Service - Rate RTOD-Demand

	<u>Current</u>	<u>Proposed</u>
Basic Service Charge per Day:	\$ 0.45	\$ 0.52
Plus an Energy Charge per kWh (Infrastructure):	\$ 0.02095	\$ 0.02095
Plus an Energy Charge per kWh (Variable):	\$ 0.03206	\$ 0.03245
Plus an Energy Charge per kWh (Total):	\$ 0.05301	\$ 0.05340
Plus a Demand Charge per kW:		
Base Hours	\$ 3.48	\$ 4.22
Peak Hours	\$ 7.62	\$ 9.25

Residential Gas Service - Rate RGS

	<u>Current</u>	<u>Proposed</u>
Basic Service Charge per Day:	\$ 0.65	\$ 0.78 per delivery point
Plus a Charge per 100 Cubic Feet:		
Distribution Charge	\$ 0.36782	\$ 0.48398
Gas Supply Cost Component	\$ 0.36675	\$ 0.36675
Total Gas Charge per 100 Cubic Feet	\$ 0.73457	\$ 0.85073

LG&E is also proposing changes to the rates for other customer classes. These customer classes and their associated annual revenue changes are listed in the tables shown below. LG&E is also proposing to change the text of some of its rate schedules and other tariff provisions and to add two optional rate schedules: General Time-of-Day Energy Service (“GTOD-Energy”) and General Time-of-Day Demand Service (“GTOD-Demand”).

LG&E's proposed rates reflect a proposed annual increase in electric revenues of approximately 11.6% and gas revenues of approximately 8.3%.

The estimated amount of the annual change and the average monthly bill to which the proposed electric rates will apply for each electric customer class are as follows:

Electric Rate Class	Average Usage (kWh)	Annual \$ Increase	Annual % Increase	Monthly Bill \$ Increase	Monthly Bill % Increase
Residential	894	53,134,815	11.80	11.74	11.81
Residential Time-of-Day	894	21,176	11.81	10.78	11.80
General Service	2,199	19,105,822	11.81	35.10	11.81
General Time-of-Day	New Rate Schedule				
Power Service	47,109	19,142,978	11.81	559.26	11.81
Time-of-Day Secondary	212,560	12,216,545	11.82	2,015.90	11.82
Time-of-Day Primary	1,261,971	16,361,581	11.81	10,361.08	11.81
Retail Transmission	6,736,478	7,690,372	11.80	49,297.26	11.80
Fluctuating Load	No Customers currently are served under this Rate Schedule				
Outdoor Lights	91	2,876,570	11.90	2.65	11.93
Lighting Energy	1,785	3	0.00	0.00	0.00
Traffic Energy	268	(14)	0.00	0.00	0.00
PSA	N/A	0	0.00	0.00	0.00
Rider – CSR	N/A	0	0.00	0.00	0.00
Outdoor Sports Lighting – Pilot Program	962	(1,638)	(10.01)	(136.45)	(10.01)

The monthly residential electric bill increase due to the proposed electric base rates will be 11.81 percent, or approximately \$11.74, for a customer using 894 kWh of electricity (the average monthly consumption of a LG&E electric residential customer).

The estimated amount of the annual change and the average monthly bill to which the proposed gas rates will apply for each gas customer class is as follows:

Gas Rate Class	Average Usage (Mcf)	Annual \$ Increase	Annual % Increase	Mthly Bill \$ Increase	Mthly Bill % Increase
Residential	5.4	22,318,158	9.37	6.17	9.37
Commercial	33.7	4,911,902	4.86	15.90	4.86
Industrial	558.8	(6)	0.00	(0.00)	0.00
As-Available	4,157.2	109,486	26.09	3,041.28	26.09
Firm Transportation	12,326.5	2,630,877	39.75	2,723.48	39.75
Distributed Generation	0.4	(1,894)	(9.50)	(79.00)	(9.52)
Substitute Gas Sales	125.0	9,170	4.82	764.15	4.82
Local Gas Delivery	No Customers are currently served under this Rate Schedule				

The monthly residential gas bill increase due to the proposed gas base rates will be 9.37 percent, or approximately \$6.17, for a customer using 54 ccf of gas (the average monthly consumption of an LG&E residential gas customer).

LG&E is also proposing an Economic Relief Surcredit Adjustment Clause, which will credit to LG&E customers a total of \$41.6 million over twelve months when new rates go into effect from this proceeding. Of that \$41.6 million, \$38.9 million will go to LG&E electric customers, and \$2.7 million will go to LG&E gas customers. For the first twelve months of new rates following this proceeding, a \$0.00343 per kWh credit will be applied to all standard electric rate schedules, and a \$0.00619 per ccf credit will be applied to all standard gas rate schedules.

LG&E is proposing to add an optional rider called Warranty Service for Customer-Owned Exterior Facilities. This rider permits firms that provide warranty service for the repair or replacement of customer-owned exterior electric facilities serving an LG&E customer's residence and connected to LG&E's distribution facilities and that meet certain standards to use LG&E's billing services to obtain payment for subscribed warranty service.

LG&E is proposing a new net metering rate schedule, Rider NMS-2, and renaming its existing Rider NMS to be Rider NMS-1. Rider NMS-1 will serve eligible electric generating facilities as defined in KRS 278.465(2) for which customers have submitted an application for net metering service before the effective date of rates established in this proceeding. Rider NMS-2 will apply to all other net metering customers. LG&E is also proposing new terms and conditions for Net Metering Service Interconnection Guidelines.

LG&E is requesting a Certificate of Public Convenience and Necessity and other associated relief to exchange all existing non-communicating electric meters in its service area with Advanced Metering Infrastructure (AMI) meters and to add AMI modules to nearly all of its existing gas meters.

LG&E proposes to eliminate certain Environmental Cost Recovery ("ECR") Projects from its ECR mechanism and monthly filings on a going-forward basis. Also, LG&E proposes to remove certain programs from its Gas Line Tracker ("GLT") rate base and recover those costs through the proposed changes in base rates. The ECR and GLT project and program eliminations and removals will result in rate base costs previously included for recovery in the ECR and GLT mechanisms being recovered through electric and gas base rates, respectively. The reductions in ECR and GLT mechanism revenues create corresponding increases in base rate revenues with no change in total revenues.

Other Charges

LG&E is proposing the following revisions to other charges in its Electric tariff:

Other Charges	Current Charge	Proposed Charge
Returned Payment Charge	\$3.00	\$3.70
Meter Test Charge	\$75.00	\$79.00
Meter Pulse Charge	\$24.00	\$21.00
Disconnect/Reconnect Service Charge w/o remote service switch	\$28.00	\$32.00
Disconnect/Reconnect Service Charge w/ remote service switch	New	\$0
Unauthorized Connection	\$70.00	\$49.00

Charge – without meter replacement		
Unauthorized Connection Charge – for single-phase standard meter replacement	\$90.00	\$70.00
Unauthorized Connection Charge – for single-phase AMR meter replacement	\$110.00	\$91.00
Unauthorized Connection Charge – for single-phase AMI meter replacement	\$174.00	\$153.00
Unauthorized Connection Charge – for three-phase meter replacement	\$177.00	\$159.00
Advanced Meter Opt-Out Charge (One-Time)	New	\$35.00
Advanced Meter Opt-Out Charge (Monthly)	New	\$12.00
Redundant Capacity - Secondary	\$1.84	\$1.93
Redundant Capacity - Primary	\$1.41	\$1.31
EVSE – Networked Single Charger	\$133.36	\$133.36
EVSE – Networked Dual Charger	\$195.48	\$195.48
EVSE – Non-Networked Single Charger	New	\$82.51
EVSE-R – Networked Single Charger	\$122.80	\$122.80
EVSE-R – Networked Dual Charger	\$174.37	\$174.37
EVSE-R Non-Networked Single Charger	New	\$30.99
EVC-L2 – Charge per Hour for First Two Hours	\$0.75	\$0.75
EVC-L2 – Charge per Hour for Every Hour After First Two Hours	\$1.00	\$1.00
EVC-FAST – Charge per kWh	N/A	\$0.25
Solar Share Program Rider (One-Time)	\$799.00	\$799.00
Solar Share Program Rider (Monthly)	\$5.55	\$5.55
Excess Facilities – w/ no CIAC	1.22%	1.23%
Excess Facilities – w/ CIAC	0.52%	0.52%
TS – Temporary-to-Permanent	15%	15%
TS – Seasonal	100%	100%

LG&E is proposing the following revisions to other charges in its Gas tariff:

Other Charges	Current Charge	Proposed Charge
---------------	----------------	-----------------

Returned Payment Charge	\$3.00	\$3.70
Meter Test Charge	\$90.00	\$101.00
Disconnect/Reconnect Service Charge	\$28.00	\$32.00
Inspection/Additional Trip Charge	\$150.00	\$155.00
Unauthorized Connection Charge – no meter replacement	\$70.00	\$49.00
Unauthorized Connection Charge – meter replacement	\$132.00	\$114.00
Advanced Meter Opt-Out Charge (One-Time)	N/A	\$33.00
Advanced Meter Opt-Out Charge (Monthly)	N/A	\$5.00
Daily Storage Charge for Daily Imbalances (TS-1 and LGDS)	\$0.3797	\$0.3797
Gas Meter Pulse Relaying Non-FT Non-TS2	\$24.34	\$28.00
Gas Meter Pulse Relaying FT/TS2	\$7.17	\$8.00
Excess Facilities – w/ no CIAC	1.15%	1.15%
Excess Facilities – w/ CIAC	0.45%	0.45%

A detailed notice of all proposed revisions and a complete copy of the proposed tariffs containing the proposed text changes, terms and conditions for electric or gas service and rates may be obtained by submitting a written request by e-mail to myaccount@lge-ku.com or by mail to Louisville Gas and Electric Company, ATTN: Rates Department, 220 West Main Street, Louisville, Kentucky, 40202, or by visiting LG&E's website at www.lge-ku.com.

A person may examine LG&E's application at the offices of LG&E located at 820 West Broadway, Louisville, Kentucky, and at LG&E's website at www.lge-ku.com. A person may also examine this application at the Public Service Commission's offices located at 211 Sower Boulevard, Frankfort, Kentucky, Monday through Friday, 8:00 a.m. to 4:30 p.m., or may view and download the application through the Commission's Web site at <http://psc.ky.gov>.

Comments regarding the application may be submitted to the Public Service Commission by mail to Public Service Commission, Post Office Box 615, Frankfort, Kentucky 40602, or by email to psc.info@ky.gov. All comments should reference Case No. 2020-00350.

The rates contained in this notice are the rates proposed by LG&E, but the Public Service Commission may order rates to be charged that differ from the proposed rates contained in this notice. A person may submit a timely written request for intervention to the Public Service Commission, Post Office Box 615, Frankfort, Kentucky 40602, establishing the grounds for the request including the status and interest of the party. If the Commission does not receive a written request for intervention within thirty (30) days of initial publication or mailing of the notice, the Commission may take final action on the application.

220 West Main Street
P. O. Box 32010
Louisville, Kentucky 40232
502-589-1444 or 800-331-7370

211 Sower Boulevard
P. O. Box 615
Frankfort, Kentucky 40602
502-564-3940

Exhibit B

**NOTICE TO CUSTOMERS OF
LOUISVILLE GAS AND ELECTRIC COMPANY**

PLEASE TAKE NOTICE that, in a November 25, 2020 Application, Louisville Gas and Electric Company (“LG&E”) is seeking approval by the Kentucky Public Service Commission of an adjustment of its electric and gas rates and charges to become effective on and after January 1, 2021.

The proposed rates reflect a proposed annual increase in electric revenues of approximately 11.6% and gas revenues of approximately 8.3% to LG&E.

The estimated amount of the annual change and the average monthly bill to which the proposed electric rates will apply for each electric customer class are as follows:

Electric Rate Class	Average Usage (kWh)	Annual \$ Increase	Annual % Increase	Monthly Bill \$ Increase	Monthly Bill % Increase
Residential	894	53,134,815	11.80	11.74	11.81
Residential Time-of-Day	894	21,176	11.81	10.78	11.80
General Service	2,199	19,105,822	11.81	35.10	11.81
General Time-of-Day	New Rate Schedule				
Power Service	47,109	19,142,978	11.81	559.26	11.81
Time-of-Day Secondary	212,560	12,216,545	11.82	2,015.90	11.82
Time-of-Day Primary	1,261,971	16,361,581	11.81	10,361.08	11.81
Retail Transmission	6,736,478	7,690,372	11.80	49,297.26	11.80
Fluctuating Load	No Customers currently are served under this Rate Schedule				
Outdoor Lights	91	2,876,570	11.90	2.65	11.93
Lighting Energy	1,785	3	0.00	0.00	0.00
Traffic Energy	268	(14)	0.00	0.00	0.00
PSA	N/A	0	0.00	0.00	0.00
Rider – CSR	N/A	0	0.00	0.00	0.00
Outdoor Sports Lighting – Pilot Program	962	(1,638)	(10.01)	(136.45)	(10.01)

The monthly residential electric bill increase due to the proposed electric base rates will be 11.81 percent, or approximately \$11.74, for a customer using 894 kWh of electricity (the average monthly consumption of an LG&E residential electric customer).

The estimated amount of the annual change and the average monthly bill to which the proposed gas rates will apply for each gas customer class is as follows:

Gas Rate Class	Average Usage (Mcf)	Annual \$ Increase	Annual % Increase	Mthly Bill \$ Increase	Mthly Bill % Increase
Residential	5.4	22,318,158	9.37	6.17	9.37
Commercial	33.7	4,911,902	4.86	15.90	4.86
Industrial	558.8	(6)	0.00	(0.00)	0.00
As-Available	4,157.2	109,486	26.09	3,041.28	26.09
Firm Transportation	12,326.5	2,630,877	39.75	2,723.48	39.75
Distributed Generation	0.4	(1,894)	(9.50)	(79.00)	(9.52)
Substitute Gas Sales	125.0	9,170	4.82	764.15	4.82
Local Gas Delivery	No Customers currently are served under this Rate Schedule.				

The monthly residential gas bill increase due to the proposed gas base rates will be 9.37 percent, or approximately \$6.17, for a customer using 54 ccf of gas (the average monthly consumption of an LG&E residential gas customer).

LG&E is also proposing an Economic Relief Surcredit Adjustment Clause, which will credit to LG&E customers a total of \$41.6 million over twelve months when new rates go into effect from this proceeding. Of that \$41.6 million, \$38.9 million will go to LG&E electric customers, and \$2.7 million will go to LG&E gas customers. For the first twelve months of new rates following this proceeding, a \$0.00343 per kWh credit will be applied to all standard electric rate schedules, and a \$0.00619 per ccf credit will be applied to all standard gas rate schedules.

LG&E is proposing to add an optional rider called Warranty Service for Customer-Owned Exterior Facilities. This rider permits firms that provide warranty service for the repair or replacement of customer-owned exterior electric facilities serving a LG&E customer's residence and connected to LG&E's distribution facilities and that meet certain standards to use LG&E's billing services to obtain payment for subscribed warranty service.

LG&E is proposing a new net metering rate schedule, Rider NMS-2, and renaming its existing Rider NMS to be Rider NMS-1. Rider NMS-1 will serve eligible electric generating facilities as defined in KRS 278.465(2) for which customers have submitted an application for net metering service before the effective date of rates established in this proceeding. Rider NMS-2 will apply to all other net metering customers. LG&E also is proposing new terms and conditions for Net Metering Service Interconnection Guidelines.

LG&E is requesting a Certificate of Public Convenience and Necessity and other associated relief to exchange all existing non-communicating electric meters in its service area with Advanced Metering Infrastructure (AMI) meters and to add AMI modules to nearly all of its existing gas meters.

LG&E proposes to eliminate certain Environmental Cost Recovery ("ECR") Projects from its ECR mechanism and monthly filings on a going-forward basis. Also, LG&E proposes to remove certain programs from its Gas Line Tracker ("GLT") rate base and recover those costs through the proposed changes in base rates. The ECR and GLT project and program eliminations and removals will result in rate base costs previously included for recovery in the ECR and GLT mechanisms being recovered through electric and gas base rates,

respectively. The reductions in ECR and GLT mechanism revenues create corresponding increases in base rate revenues with no change in total revenues.

LG&E also is proposing changes in the text of some of its rate schedules and other tariff provisions, including its terms and conditions for electric or gas service. Complete copies of the proposed tariffs containing the proposed text changes and rates may be obtained by contacting Louisville Gas and Electric Company by mail at 220 West Main Street, Louisville, Kentucky, 40202; by phone at 502-589-1444 or 800-331-7370; or by visiting LG&E's website at lge-ku.com.

Notice is further given that a person may examine this application at the offices of LG&E located at 820 West Broadway, Louisville, Kentucky; the application also may be examined at LG&E's website at lge-ku.com. A person also may examine this application at the Public Service Commission's offices located at 211 Sower Boulevard, Frankfort, Kentucky, Monday through Friday, 8 a.m. to 4:30 p.m., or through the Commission's website at <http://psc.ky.gov>.

Comments regarding the application may be submitted to the Public Service Commission by mail to Public Service Commission, Post Office Box 615, Frankfort, Kentucky 40602 or by email to psc.info@ky.gov. All comments should reference Case No. 2020-00350.

The rates contained in this notice are the rates proposed by LG&E, but the Public Service Commission may order rates to be charged that differ from the proposed rates contained in this notice. A person may submit a timely written request for intervention to the Public Service Commission, Post Office Box 615, Frankfort, Kentucky 40602 establishing the grounds for the request including the status and interest of the party. If the Commission does not receive a written request for intervention within thirty (30) days of initial publication or mailing of this notice, the Commission may take final action on the application.

A copy of the Notice of Filing and the proposed tariff, once filed, also shall be available for public inspection on LG&E's website at lge-ku.com or through the Public Service Commission's website at <http://psc.ky.gov>.

Louisville Gas and Electric Company
220 West Main Street
P. O. Box 32010
Louisville, Kentucky 40232
502-589-1444 or 800-331-7370

Public Service Commission
211 Sower Boulevard
P. O. Box 615
Frankfort, Kentucky 40602
502-564-3940

EXHIBIT 2

CUSTOMER NOTICE OF RATE ADJUSTMENT

PLEASE TAKE NOTICE that, in a November 25, 2020, Application, Louisville Gas and Electric Company (“LG&E”) is seeking approval by the Kentucky Public Service Commission of an adjustment of its electric and gas rates and charges to become effective on and after January 1, 2021.

LG&E CURRENT AND PROPOSED RESIDENTIAL ELECTRIC AND GAS RATES

Residential Service - Rate RS

	<u>Current</u>	<u>Proposed</u>
Basic Service Charge per Day:	\$ 0.45	\$ 0.52
Plus an Energy Charge per kWh:		
Infrastructure:	\$ 0.06072	\$ 0.07237
Variable:	\$ 0.03206	\$ 0.03245
Total:	\$ 0.09278	\$ 0.10482

Residential Time-of-Day Energy Service - Rate RTOD-Energy

	<u>Current</u>	<u>Proposed</u>
Basic Service Charge per Day:	\$ 0.45	\$ 0.52
Plus an Energy Charge per kWh:		
Off-Peak Hours (Infrastructure):	\$ 0.03874	\$ 0.04935
Off-Peak Hours (Variable):	\$ 0.03206	\$ 0.03245
Off-Peak Hours (Total):	\$ 0.07080	\$ 0.08180
On-Peak Hours (Infrastructure):	\$ 0.17302	\$ 0.14704
On-Peak Hours (Variable):	\$ 0.03206	\$ 0.03245
On-Peak Hours (Total):	\$ 0.20508	\$ 0.17949

Residential Time-of-Day Demand Service - Rate RTOD-Demand

	<u>Current</u>	<u>Proposed</u>
Basic Service Charge per Day:	\$ 0.45	\$ 0.52
Plus an Energy Charge per kWh (Infrastructure):	\$ 0.02095	\$ 0.02095
Plus an Energy Charge per kWh (Variable):	\$ 0.03206	\$ 0.03245
Plus an Energy Charge per kWh (Total):	\$ 0.05301	\$ 0.05340
Plus a Demand Charge per kW:		
Base Hours	\$ 3.48	\$ 4.22
Peak Hours	\$ 7.62	\$ 9.25

Residential Gas Service - Rate RGS

	<u>Current</u>	<u>Proposed</u>
Basic Service Charge per Day:	\$ 0.65	\$ 0.78 per delivery point
Plus a Charge per 100 Cubic Feet:		
Distribution Charge	\$ 0.36782	\$ 0.48398
Gas Supply Cost Component	\$ 0.36675	\$ 0.36675
Total Gas Charge per 100 Cubic Feet	\$ 0.73457	\$ 0.85073

LG&E is also proposing changes to the rates for other customer classes. These customer classes and their associated annual revenue changes are listed in the tables shown below. LG&E is also proposing to change the text of some of its rate schedules and other tariff provisions and to add two optional rate schedules: General Time-of-Day Energy Service (“GTOD-Energy”) and General Time-of-Day Demand Service (“GTOD-Demand”).

LG&E's proposed rates reflect a proposed annual increase in electric revenues of approximately 11.6% and gas revenues of approximately 8.3%.

The estimated amount of the annual change and the average monthly bill to which the proposed electric rates will apply for each electric customer class are as follows:

Electric Rate Class	Average Usage (kWh)	Annual \$ Increase	Annual % Increase	Monthly Bill \$ Increase	Monthly Bill % Increase
Residential	894	53,134,815	11.80	11.74	11.81
Residential Time-of-Day	894	21,176	11.81	10.78	11.80
General Service	2,199	19,105,822	11.81	35.10	11.81
General Time-of-Day	New Rate Schedule				
Power Service	47,109	19,142,978	11.81	559.26	11.81
Time-of-Day Secondary	212,560	12,216,545	11.82	2,015.90	11.82
Time-of-Day Primary	1,261,971	16,361,581	11.81	10,361.08	11.81
Retail Transmission	6,736,478	7,690,372	11.80	49,297.26	11.80
Fluctuating Load	No Customers currently are served under this Rate Schedule				
Outdoor Lights	91	2,876,570	11.90	2.65	11.93
Lighting Energy	1,785	3	0.00	0.00	0.00
Traffic Energy	268	(14)	0.00	0.00	0.00
PSA	N/A	0	0.00	0.00	0.00
Rider – CSR	N/A	0	0.00	0.00	0.00
Outdoor Sports Lighting – Pilot Program	962	(1,638)	(10.01)	(136.45)	(10.01)

The monthly residential electric bill increase due to the proposed electric base rates will be 11.81 percent, or approximately \$11.74, for a customer using 894 kWh of electricity (the average monthly consumption of a LG&E electric residential customer).

The estimated amount of the annual change and the average monthly bill to which the proposed gas rates will apply for each gas customer class is as follows:

Gas Rate Class	Average Usage (Mcf)	Annual \$ Increase	Annual % Increase	Mthly Bill \$ Increase	Mthly Bill % Increase
Residential	5.4	22,318,158	9.37	6.17	9.37
Commercial	33.7	4,911,902	4.86	15.90	4.86
Industrial	558.8	(6)	0.00	(0.00)	0.00
As-Available	4,157.2	109,486	26.09	3,041.28	26.09
Firm Transportation	12,326.5	2,630,877	39.75	2,723.48	39.75
Distributed Generation	0.4	(1,894)	(9.50)	(79.00)	(9.52)
Substitute Gas Sales	125.0	9,170	4.82	764.15	4.82
Local Gas Delivery	No Customers are currently served under this Rate Schedule				

The monthly residential gas bill increase due to the proposed gas base rates will be 9.37 percent, or approximately \$6.17, for a customer using 54 ccf of gas (the average monthly consumption of an LG&E residential gas customer).

LG&E is also proposing an Economic Relief Surcredit Adjustment Clause, which will credit to LG&E customers a total of \$41.6 million over twelve months when new rates go into effect from this proceeding. Of that \$41.6 million, \$38.9 million will go to LG&E electric customers, and \$2.7 million will go to LG&E gas customers. For the first twelve months of new rates following this proceeding, a \$0.00343 per kWh credit will be applied to all standard electric rate schedules, and a \$0.00619 per ccf credit will be applied to all standard gas rate schedules.

LG&E is proposing to add an optional rider called Warranty Service for Customer-Owned Exterior Facilities. This rider permits firms that provide warranty service for the repair or replacement of customer-owned exterior electric facilities serving an LG&E customer's residence and connected to LG&E's distribution facilities and that meet certain standards to use LG&E's billing services to obtain payment for subscribed warranty service.

LG&E is proposing a new net metering rate schedule, Rider NMS-2, and renaming its existing Rider NMS to be Rider NMS-1. Rider NMS-1 will serve eligible electric generating facilities as defined in KRS 278.465(2) for which customers have submitted an application for net metering service before the effective date of rates established in this proceeding. Rider NMS-2 will apply to all other net metering customers. LG&E is also proposing new terms and conditions for Net Metering Service Interconnection Guidelines.

LG&E is requesting a Certificate of Public Convenience and Necessity and other associated relief to exchange all existing non-communicating electric meters in its service area with Advanced Metering Infrastructure (AMI) meters and to add AMI modules to nearly all of its existing gas meters.

LG&E proposes to eliminate certain Environmental Cost Recovery ("ECR") Projects from its ECR mechanism and monthly filings on a going-forward basis. Also, LG&E proposes to remove certain programs from its Gas Line Tracker ("GLT") rate base and recover those costs through the proposed changes in base rates. The ECR and GLT project and program eliminations and removals will result in rate base costs previously included for recovery in the ECR and GLT mechanisms being recovered through electric and gas base rates, respectively. The reductions in ECR and GLT mechanism revenues create corresponding increases in base rate revenues with no change in total revenues.

Other Charges

LG&E is proposing the following revisions to other charges in its Electric tariff:

Other Charges	Current Charge	Proposed Charge
Returned Payment Charge	\$3.00	\$3.70
Meter Test Charge	\$75.00	\$79.00
Meter Pulse Charge	\$24.00	\$21.00
Disconnect/Reconnect Service Charge w/o remote service switch	\$28.00	\$32.00
Disconnect/Reconnect Service Charge w/ remote service switch	New	\$0
Unauthorized Connection Charge – without meter replacement	\$70.00	\$49.00
Unauthorized Connection Charge – for single-phase standard meter replacement	\$90.00	\$70.00
Unauthorized Connection Charge – for single-	\$110.00	\$91.00

phase AMR meter replacement		
Unauthorized Connection Charge – for single-phase AMI meter replacement	\$174.00	\$153.00
Unauthorized Connection Charge – for three-phase meter replacement	\$177.00	\$159.00
Advanced Meter Opt-Out Charge (One-Time)	New	\$35.00
Advanced Meter Opt-Out Charge (Monthly)	New	\$12.00
Redundant Capacity - Secondary	\$1.84	\$1.93
Redundant Capacity - Primary	\$1.41	\$1.31
EVSE – Networked Single Charger	\$133.36	\$133.36
EVSE – Networked Dual Charger	\$195.48	\$195.48
EVSE – Non-Networked Single Charger	New	\$82.51
EVSE-R – Networked Single Charger	\$122.80	\$122.80
EVSE-R – Networked Dual Charger	\$174.37	\$174.37
EVSE-R Non-Networked Single Charger	New	\$30.99
EVC-L2 – Charge per Hour for First Two Hours	\$0.75	\$0.75
EVC-L2 – Charge per Hour for Every Hour After First Two Hours	\$1.00	\$1.00
EVC-FAST – Charge per kWh	N/A	\$0.25
Solar Share Program Rider (One-Time)	\$799.00	\$799.00
Solar Share Program Rider (Monthly)	\$5.55	\$5.55
Excess Facilities – w/ no CIAC	1.22%	1.23%
Excess Facilities – w/ CIAC	0.52%	0.52%
TS – Temporary-to-Permanent	15%	15%
TS – Seasonal	100%	100%

LG&E is proposing the following revisions to other charges in its Gas tariff:

Other Charges	Current Charge	Proposed Charge
Returned Payment Charge	\$3.00	\$3.70
Meter Test Charge	\$90.00	\$101.00
Disconnect/Reconnect Service Charge	\$28.00	\$32.00
Inspection/Additional Trip Charge	\$150.00	\$155.00
Unauthorized Connection Charge – no meter replacement	\$70.00	\$49.00
Unauthorized Connection Charge – meter replacement	\$132.00	\$114.00
Advanced Meter Opt-Out Charge (One-Time)	N/A	\$33.00
Advanced Meter Opt-Out Charge (Monthly)	N/A	\$5.00
Daily Storage Charge for Daily Imbalances (TS-1 and LGDS)	\$0.3797	\$0.3797
Gas Meter Pulse Relaying Non-FT Non-TS2	\$24.34	\$28.00
Gas Meter Pulse Relaying FT/TS2	\$7.17	\$8.00
Excess Facilities – w/ no CIAC	1.15%	1.15%
Excess Facilities – w/ CIAC	0.45%	0.45%

A detailed notice of all proposed revisions and a complete copy of the proposed tariffs containing the proposed text changes, terms and conditions for electric or gas service and rates may be obtained by submitting a written request by e-mail to myaccount@lge-ku.com or by

mail to Louisville Gas and Electric Company, ATTN: Rates Department, 220 West Main Street, Louisville, Kentucky, 40202, or by visiting LG&E's website at www.lge-ku.com.

A person may examine LG&E's application at the offices of LG&E located at 820 West Broadway, Louisville, Kentucky, and at LG&E's website at www.lge-ku.com. A person may also examine this application at the Public Service Commission's offices located at 211 Sower Boulevard, Frankfort, Kentucky, Monday through Friday, 8:00 a.m. to 4:30 p.m., or may view and download the application through the Commission's Web site at <http://psc.ky.gov>.

Comments regarding the application may be submitted to the Public Service Commission by mail to Public Service Commission, Post Office Box 615, Frankfort, Kentucky 40602, or by email to psc.info@ky.gov. All comments should reference Case No. 2020-00350.

The rates contained in this notice are the rates proposed by LG&E, but the Public Service Commission may order rates to be charged that differ from the proposed rates contained in this notice. A person may submit a timely written request for intervention to the Public Service Commission, Post Office Box 615, Frankfort, Kentucky 40602, establishing the grounds for the request including the status and interest of the party. If the Commission does not receive a written request for intervention within thirty (30) days of initial publication or mailing of the notice, the Commission may take final action on the application.

Louisville Gas and Electric Company
220 West Main Street
P. O. Box 32010
Louisville, Kentucky 40232
502-589-1444 or 800-331-7370

Public Service Commission
211 Sower Boulevard
P. O. Box 615
Frankfort, Kentucky 40602
502-564-3940

EXHIBIT 3

CUSTOMER NOTICE OF RATE ADJUSTMENT

PLEASE TAKE NOTICE that, in a November 25, 2020, Application, Louisville Gas and Electric Company (“LG&E”) is seeking approval by the Kentucky Public Service Commission of an adjustment of its electric and gas rates and charges to become effective on and after January 1, 2021.

LG&E CURRENT AND PROPOSED RESIDENTIAL ELECTRIC AND GAS RATES

Residential Service - Rate RS

	<u>Current</u>	<u>Proposed</u>
Basic Service Charge per Day:	\$ 0.45	\$ 0.52
Plus an Energy Charge per kWh:		
Infrastructure:	\$ 0.06072	\$ 0.07237
Variable:	\$ 0.03206	\$ 0.03245
Total:	\$ 0.09278	\$ 0.10482

Residential Time-of-Day Energy Service - Rate RTOD-Energy

	<u>Current</u>	<u>Proposed</u>
Basic Service Charge per Day:	\$ 0.45	\$ 0.52
Plus an Energy Charge per kWh:		
Off-Peak Hours (Infrastructure):	\$ 0.03874	\$ 0.04935
Off-Peak Hours (Variable):	\$ 0.03206	\$ 0.03245
Off-Peak Hours (Total):	\$ 0.07080	\$ 0.08180
On-Peak Hours (Infrastructure):	\$ 0.17302	\$ 0.14704
On-Peak Hours (Variable):	\$ 0.03206	\$ 0.03245
On-Peak Hours (Total):	\$ 0.20508	\$ 0.17949

Residential Time-of-Day Demand Service - Rate RTOD-Demand

	<u>Current</u>	<u>Proposed</u>
Basic Service Charge per Day:	\$ 0.45	\$ 0.52
Plus an Energy Charge per kWh (Infrastructure):	\$ 0.02095	\$ 0.02095
Plus an Energy Charge per kWh (Variable):	\$ 0.03206	\$ 0.03245
Plus an Energy Charge per kWh (Total):	\$ 0.05301	\$ 0.05340
Plus a Demand Charge per kW:		
Base Hours	\$ 3.48	\$ 4.22
Peak Hours	\$ 7.62	\$ 9.25

Residential Gas Service - Rate RGS

	<u>Current</u>	<u>Proposed</u>
Basic Service Charge per Day:	\$ 0.65	\$ 0.78 per delivery point
Plus a Charge per 100 Cubic Feet:		
Distribution Charge	\$ 0.36782	\$ 0.48398
Gas Supply Cost Component	<u>\$ 0.36675</u>	<u>\$ 0.36675</u>
Total Gas Charge per 100 Cubic Feet	\$ 0.73457	\$ 0.85073

LG&E is also proposing changes to the rates for other customer classes. These customer classes and their associated annual revenue changes are listed in the tables shown below. LG&E is also proposing to change the text of some of its rate schedules and other tariff provisions and to add two optional rate schedules: General Time-of-Day Energy Service (“GTOD-Energy”) and General Time-of-Day Demand Service (“GTOD-Demand”).

LG&E's proposed rates reflect a proposed annual increase in electric revenues of approximately 11.6% and gas revenues of approximately 8.3%.

The estimated amount of the annual change and the average monthly bill to which the proposed electric rates will apply for each electric customer class are as follows:

Electric Rate Class	Average Usage (kWh)	Annual \$ Increase	Annual % Increase	Monthly Bill \$ Increase	Monthly Bill % Increase
Residential	894	53,134,815	11.80	11.74	11.81
Residential Time-of-Day	894	21,176	11.81	10.78	11.80
General Service	2,199	19,105,822	11.81	35.10	11.81
General Time-of-Day	New Rate Schedule				
Power Service	47,109	19,142,978	11.81	559.26	11.81
Time-of-Day Secondary	212,560	12,216,545	11.82	2,015.90	11.82
Time-of-Day Primary	1,261,971	16,361,581	11.81	10,361.08	11.81
Retail Transmission	6,736,478	7,690,372	11.80	49,297.26	11.80
Fluctuating Load	No Customers currently are served under this Rate Schedule				
Outdoor Lights	91	2,876,570	11.90	2.65	11.93
Lighting Energy	1,785	3	0.00	0.00	0.00
Traffic Energy	268	(14)	0.00	0.00	0.00
PSA	N/A	0	0.00	0.00	0.00
Rider – CSR	N/A	0	0.00	0.00	0.00
Outdoor Sports Lighting – Pilot Program	962	(1,638)	(10.01)	(136.45)	(10.01)

The monthly residential electric bill increase due to the proposed electric base rates will be 11.81 percent, or approximately \$11.74, for a customer using 894 kWh of electricity (the average monthly consumption of a LG&E electric residential customer).

The estimated amount of the annual change and the average monthly bill to which the proposed gas rates will apply for each gas customer class is as follows:

Gas Rate Class	Average Usage (Mcf)	Annual \$ Increase	Annual % Increase	Mthly Bill \$ Increase	Mthly Bill % Increase
Residential	5.4	22,318,158	9.37	6.17	9.37
Commercial	33.7	4,911,902	4.86	15.90	4.86
Industrial	558.8	(6)	0.00	(0.00)	0.00
As-Available	4,157.2	109,486	26.09	3,041.28	26.09
Firm Transportation	12,326.5	2,630,877	39.75	2,723.48	39.75
Distributed Generation	0.4	(1,894)	(9.50)	(79.00)	(9.52)
Substitute Gas Sales	125.0	9,170	4.82	764.15	4.82
Local Gas Delivery	No Customers are currently served under this Rate Schedule				

The monthly residential gas bill increase due to the proposed gas base rates will be 9.37 percent, or approximately \$6.17, for a customer using 54 ccf of gas (the average monthly consumption of an LG&E residential gas customer).

LG&E is also proposing an Economic Relief Surcredit Adjustment Clause, which will credit to LG&E customers a total of \$41.6 million over twelve months when new rates go into effect from this proceeding. Of that \$41.6 million, \$38.9 million will go to LG&E electric customers, and \$2.7 million will go to LG&E gas customers. For the first twelve months of new rates following this proceeding, a \$0.00343 per kWh credit will be applied to all standard electric rate schedules, and a \$0.00619 per ccf credit will be applied to all standard gas rate schedules.

LG&E is proposing to add an optional rider called Warranty Service for Customer-Owned Exterior Facilities. This rider permits firms that provide warranty service for the repair or replacement of customer-owned exterior electric facilities serving an LG&E customer's residence and connected to LG&E's distribution facilities and that meet certain standards to use LG&E's billing services to obtain payment for subscribed warranty service.

LG&E is proposing a new net metering rate schedule, Rider NMS-2, and renaming its existing Rider NMS to be Rider NMS-1. Rider NMS-1 will serve eligible electric generating facilities as defined in KRS 278.465(2) for which customers have submitted an application for net metering service before the effective date of rates established in this proceeding. Rider NMS-2 will apply to all other net metering customers. LG&E is also proposing new terms and conditions for Net Metering Service Interconnection Guidelines.

LG&E is requesting a Certificate of Public Convenience and Necessity and other associated relief to exchange all existing non-communicating electric meters in its service area with Advanced Metering Infrastructure (AMI) meters and to add AMI modules to nearly all of its existing gas meters.

LG&E proposes to eliminate certain Environmental Cost Recovery ("ECR") Projects from its ECR mechanism and monthly filings on a going-forward basis. Also, LG&E proposes to remove certain programs from its Gas Line Tracker ("GLT") rate base and recover those costs through the proposed changes in base rates. The ECR and GLT project and program eliminations and removals will result in rate base costs previously included for recovery in the ECR and GLT mechanisms being recovered through electric and gas base rates, respectively. The reductions in ECR and GLT mechanism revenues create corresponding increases in base rate revenues with no change in total revenues.

Other Charges

LG&E is proposing the following revisions to other charges in its Electric tariff:

Other Charges	Current Charge	Proposed Charge
Returned Payment Charge	\$3.00	\$3.70
Meter Test Charge	\$75.00	\$79.00
Meter Pulse Charge	\$24.00	\$21.00
Disconnect/Reconnect Service Charge w/o remote service switch	\$28.00	\$32.00
Disconnect/Reconnect Service Charge w/ remote service switch	New	\$0
Unauthorized Connection Charge – without meter replacement	\$70.00	\$49.00
Unauthorized Connection Charge – for single-phase standard meter replacement	\$90.00	\$70.00
Unauthorized Connection Charge – for single-	\$110.00	\$91.00

phase AMR meter replacement		
Unauthorized Connection Charge – for single-phase AMI meter replacement	\$174.00	\$153.00
Unauthorized Connection Charge – for three-phase meter replacement	\$177.00	\$159.00
Advanced Meter Opt-Out Charge (One-Time)	New	\$35.00
Advanced Meter Opt-Out Charge (Monthly)	New	\$12.00
Redundant Capacity - Secondary	\$1.84	\$1.93
Redundant Capacity - Primary	\$1.41	\$1.31
EVSE – Networked Single Charger	\$133.36	\$133.36
EVSE – Networked Dual Charger	\$195.48	\$195.48
EVSE – Non-Networked Single Charger	New	\$82.51
EVSE-R – Networked Single Charger	\$122.80	\$122.80
EVSE-R – Networked Dual Charger	\$174.37	\$174.37
EVSE-R Non-Networked Single Charger	New	\$30.99
EVC-L2 – Charge per Hour for First Two Hours	\$0.75	\$0.75
EVC-L2 – Charge per Hour for Every Hour After First Two Hours	\$1.00	\$1.00
EVC-FAST – Charge per kWh	N/A	\$0.25
Solar Share Program Rider (One-Time)	\$799.00	\$799.00
Solar Share Program Rider (Monthly)	\$5.55	\$5.55
Excess Facilities – w/ no CIAC	1.22%	1.23%
Excess Facilities – w/ CIAC	0.52%	0.52%
TS – Temporary-to-Permanent	15%	15%
TS – Seasonal	100%	100%

LG&E is proposing the following revisions to other charges in its Gas tariff:

Other Charges	Current Charge	Proposed Charge
Returned Payment Charge	\$3.00	\$3.70
Meter Test Charge	\$90.00	\$101.00
Disconnect/Reconnect Service Charge	\$28.00	\$32.00
Inspection/Additional Trip Charge	\$150.00	\$155.00
Unauthorized Connection Charge – no meter replacement	\$70.00	\$49.00
Unauthorized Connection Charge – meter replacement	\$132.00	\$114.00
Advanced Meter Opt-Out Charge (One-Time)	N/A	\$33.00
Advanced Meter Opt-Out Charge (Monthly)	N/A	\$5.00
Daily Storage Charge for Daily Imbalances (TS-1 and LGDS)	\$0.3797	\$0.3797
Gas Meter Pulse Relaying Non-FT Non-TS2	\$24.34	\$28.00
Gas Meter Pulse Relaying FT/TS2	\$7.17	\$8.00
Excess Facilities – w/ no CIAC	1.15%	1.15%
Excess Facilities – w/ CIAC	0.45%	0.45%

A detailed notice of all proposed revisions and a complete copy of the proposed tariffs containing the proposed text changes, terms and conditions for electric or gas service and rates may be obtained by submitting a written request by e-mail to myaccount@lge-ku.com or by

mail to Louisville Gas and Electric Company, ATTN: Rates Department, 220 West Main Street, Louisville, Kentucky, 40202, or by visiting LG&E's website at www.lge-ku.com.

A person may examine LG&E's application at the offices of LG&E located at 820 West Broadway, Louisville, Kentucky, and at LG&E's website at www.lge-ku.com. A person may also examine this application at the Public Service Commission's offices located at 211 Sower Boulevard, Frankfort, Kentucky, Monday through Friday, 8:00 a.m. to 4:30 p.m., or may view and download the application through the Commission's Web site at <http://psc.ky.gov>.

Comments regarding the application may be submitted to the Public Service Commission by mail to Public Service Commission, Post Office Box 615, Frankfort, Kentucky 40602, or by email to psc.info@ky.gov. All comments should reference Case No. 2020-00350.

The rates contained in this notice are the rates proposed by LG&E, but the Public Service Commission may order rates to be charged that differ from the proposed rates contained in this notice. A person may submit a timely written request for intervention to the Public Service Commission, Post Office Box 615, Frankfort, Kentucky 40602, establishing the grounds for the request including the status and interest of the party. If the Commission does not receive a written request for intervention within thirty (30) days of initial publication or mailing of the notice, the Commission may take final action on the application.

Louisville Gas and Electric Company
220 West Main Street
P. O. Box 32010
Louisville, Kentucky 40232
502-589-1444 or 800-331-7370

Public Service Commission
211 Sower Boulevard
P. O. Box 615
Frankfort, Kentucky 40602
502-564-3940

EXHIBIT 4

Louisville Gas and Electric Company

P.S.C. Electric No. 9, First Revision of Original Sheet No. 57.6
Canceling P.S.C. Electric No. 9, Original Sheet No. 57.6

Standard Rate Rider

NMS
Net Metering Service

LEVEL 1

Expansion of system:
Adding: 4.44 kW DC & 3.80 kW AC

Application for Interconnection and Net Metering

Use this application form only for a generating facility that is inverter based and certified by a nationally recognized testing laboratory to meet the requirements of UL 1741.

Submit this Application to:

Louisville Gas and Electric Company, Attn: Customer Commitment,
P. O. Box 32010, Louisville, KY 40232

If you have questions regarding this Application or its status, contact LG&E at:

502-627-2202 or customer.commitment@lge-ku.com

Customer Name: _____ Account Number: _____

Customer Address: _____

Customer Phone No.: _____ Customer E-mail Address: _____

Project Contact Person: _____

Phone No.: _____ E-mail Address (Optional): _____

Provide names and contact information for other contractors, installers, or engineering firms involved in the design and installation of the generating facilities: Solar Energy Solutions: additional panels added to existing array.

Energy Source: Solar Wind Hydro Biogas Biomass
Existing

ADDING (12) LG370W
MODULES = 4.44 kW DC

Inverter Manufacturer and Model #: _____

Inverter Power Rating: total: 11.40 kW AC _____ Inverter Voltage Rating: _____

Power Rating of Energy Source (i.e., solar panels, wind turbine): ~~Existing: 8.82 kW DC, Adding: 4.44 kW DC~~

Is Battery Storage Used: No Yes If Yes, Battery Power Rating: ~~9.8 kW~~

Attach documentation showing that inverter is certified by a nationally recognized testing laboratory to meet the requirements of UL 1741.

Attach site drawing or sketch showing location of Utility's meter, energy source, (*optional: Utility accessible disconnect switch*) and inverter.

Attach single line drawing showing all electrical equipment from the Utility's metering location to the energy source including switches, fuses, breakers, panels, transformers, inverters, energy source, wire size, equipment ratings, and transformer connections.

Expected Start-up Date: 10/31/21 _____

DATE OF ISSUE: January 31, 2013

DATE EFFECTIVE: November 1, 2010

ISSUED BY: /s/ Lonnie E. Bellar, Vice President
State Regulation and Rates
Louisville, Kentucky

Issued by Authority of an Order of the
Public Service Commission in Case No.
2009-00549 dated July 30, 2010 and
2010-00204 dated September 30, 2010

WIRING DESCRIPTIONS

TAG	DESCRIPTION	CONDUIT TYPE/SIZE	CONDUCTOR TYPE/SIZE	NOTES
1	RUN TO INVERTER	1" EMT	10 AWG CU, 6 AWG GND	
2	INVERTER TO AC DISCONNECT	1" EMT	8 AWG CU, 6 AWG GND	
3	AC DISCONNECT TO LINESIDE TAP	N/A	(3) 6 AWG CU	
4	INVERTER TO BATTERIES	2" PVC	10 AWG CU	
5	INVERTER TO AC DISCONNECT	1" EMT	(3) 6 AWG CU, 6 AWG GND	

EXPANSION = 4.44 kW DC, 3.80 kW AC

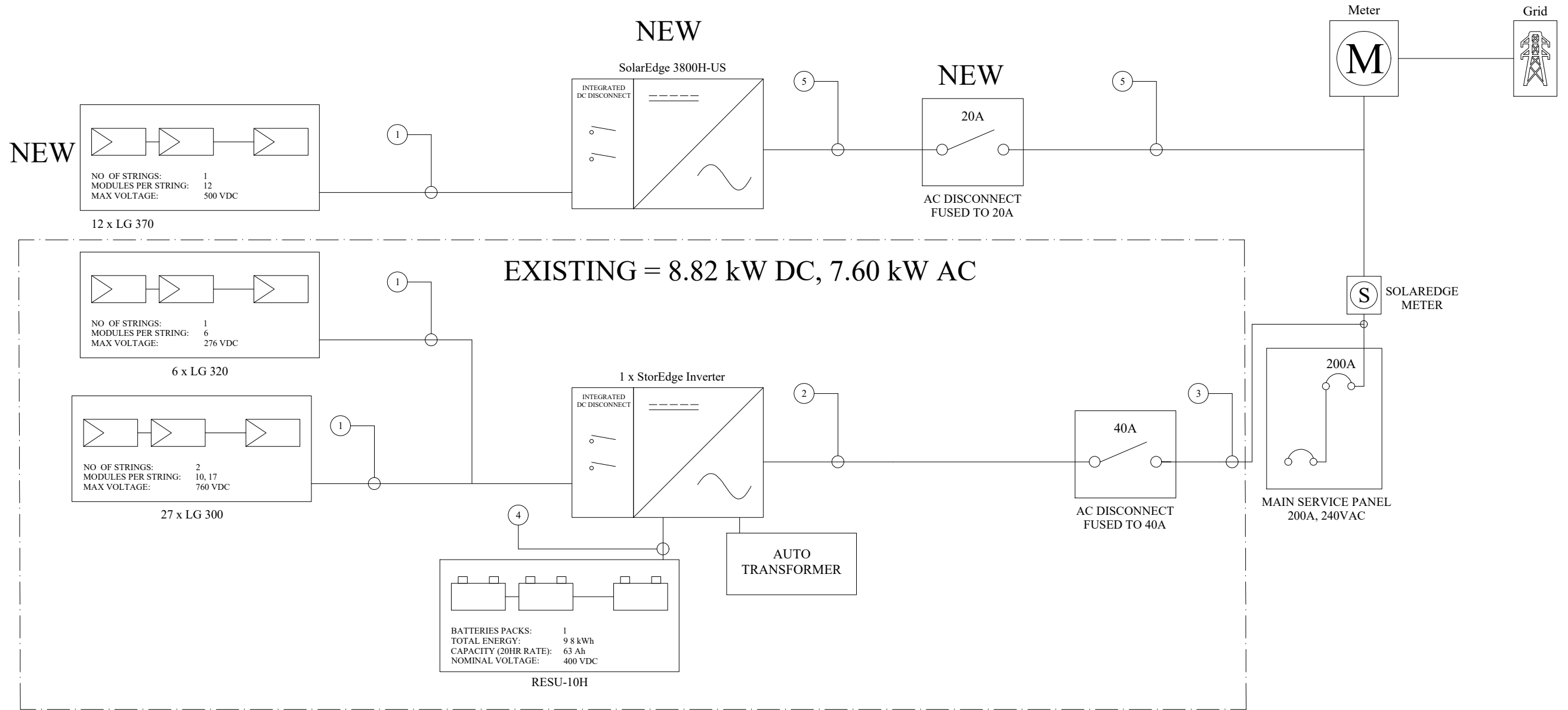

EXISTING Module Specifications	
23 x LG Solar 300W	
STC Rating	300 W
Vmp	33.6 V
Imp	9.53 A
Voc	40.9 V
Isc	10.05 A
TOTAL DC POWER RATING	6.90 kW

EXISTING Module Specifications	
6 x LG Solar 320W	
STC Rating	320 W
Vmp	33.6 V
Imp	9.53 A
Voc	40.9 V
Isc	10.05 A
TOTAL DC POWER RATING	1.92 kW

EXISTING Inverter Specifications	
1x SolarEdge Storage	
WATTAGE PER INVERTER:	7.60 kW
NOMINAL VOLTAGE:	240 VAC
MAX OUTPUT CURRENT:	32 A
MAX AC OUTPUT:	8.35 kW
TOTAL AC POWER RATING	7.60 kW

NEW Module Specifications	
12 x LG Solar 370W	
STC Rating	370 W
Vmp	33.6 V
Imp	9.53 A
Voc	40.9 V
Isc	10.05 A
TOTAL DC POWER RATING	4.44 kW

NEW Inverter Specifications	
1x SolarEdge 3800H-US	
WATTAGE PER INVERTER:	3.80 kW
NOMINAL VOLTAGE:	240 VAC
MAX OUTPUT CURRENT:	15 A
MAX AC OUTPUT:	3.8 kW
TOTAL AC POWER RATING	3.8 kW



Solar Electric - Photovoltaics - PV
 Solar Thermal - Solar Hot Water
 1038 Brentwood Ct., Suite B
 Lexington, KY 40511
 Tel: (859) 312-7456
 Fax: (866) 830-0418
 www.solar-energy-solutions.com

PROJECT	Ricketts Expansion III		SHEET 1 OF 1	
REV	DESCRIPTION	DATE	BY	CHK
A	WIRING DIAGRAM	OCT 31 21	CSA	
B				
ADDRESS	214 Kennedy Ave, Louisville, KY			

3RD EXPANSION TOTAL VALUES: 14.46 kW DC, 11.4 kW AC

ADDING:
(12) LG 370W
4.44 kW DC
+
(1) SolarEdge SE3800H
3.8 kW AC

EXISTING:
(27) LG 300W
8.10 kW DC
+
(6) LG 320W
1.92 kW DC

(1) SolarEdge SE7600H
7.6 kW AC



Notes:

Panel: 39.37" x 64.57"
Address: 214 Kennedy Ave,
 Louisville, KY

1038 Brentwood Ct, STE B tel: (859) 312-7456
 Lexington, KY 40511 fax: (866) 830-0418
 www.solar-energy-solutions.com
 Solar Electric - Photovoltaics - PV
 Solar Thermal - Solar Hot Water

PROJECT	7086 - Ricketts Expansion II	SHEET 1 OF 1		
REV	DESCRIPTION	DATE	BY	CHK
A	LAYOUT FOR SOLAR ARRAY	Oct 4, 2018	CDB	
B				

Detailed Layout



EXISTING SYSTEM LAYOUT

1st System: (27) LG 300W

2nd Expansion of System: (6) LG 320W

3rd Expansion of System: (12) LG 370W

LG NeON[®] R

LG370Q1C-V5 | LG365Q1C-V5

60

370W | 365W

LG NeON[®] R is powerful solar module that provides world-class performance. A new cell structure that eliminates electrodes on the front maximizes the utilization of light and enhances reliability. LG NeON[®] R is a result of LG's efforts to increase customer's values beyond efficiency. LG NeON[®] R features enhanced durability, performance under real-world conditions, an enhanced warranty and aesthetic design suitable for roofs.

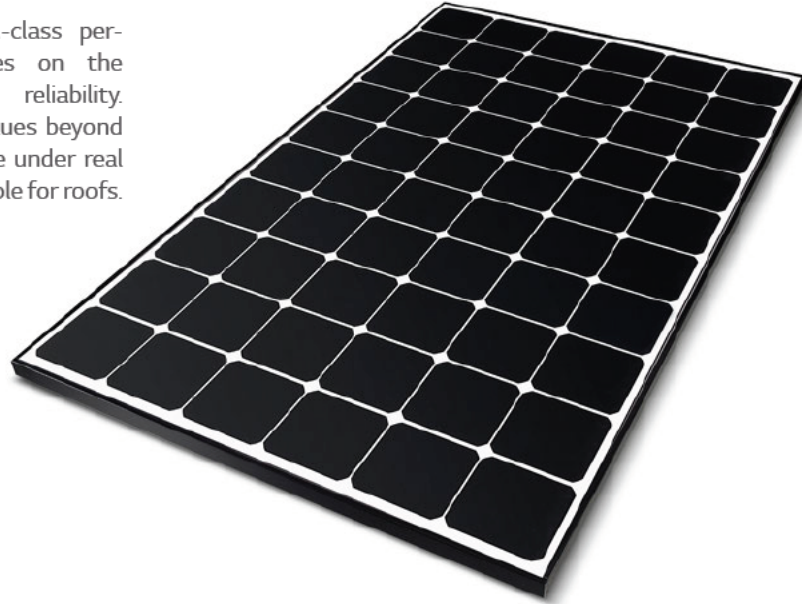

Features



Aesthetic Roof

LG NeON[®] R has been designed with aesthetics in mind: the lack of any electrodes on the front creates an improved, modern aesthetic.



Extended Product Warranty

LG has extended the product warranty of the LG NeON[®] R to 25 years which is top level of the industry.



Better Performance on a Sunny Day

LG NeON[®] R now performs better on sunny days, thanks to its improved temperature coefficient.



More generation per square meter

The LG NeON[®] R has been designed to significantly enhance its output, making it efficient even in limited space.

About LG Electronics

LG Electronics is a global big player, committed to expanding its operations with the solar market. The company first embarked on a solar energy source research program in 1985, supported by LG Group's vast experience in the semi-conductor, LCD, chemistry and materials industries. In 2010, LG Solar successfully released its first MonoX[®] series to the market, which is now available in 32 countries. The NeON[®] (previous MonoX[®] NeON), NeON[®]2, NeON[®]2 BiFacial won the "Intersolar AWARD" in 2013, 2015 and 2016, which demonstrates LG Solar's lead, innovation and commitment to the industry.



LG N_eON[®]R

LG370Q1C-V5 | LG365Q1C-V5

General Data

Cell Properties(Material / Type)	Monocrystalline / N-type
Cell Maker	LG
Cell Configuration	60 Cells (6 x 10)
Module Dimensions(L x W x H)	1,700mm x 1,016mm x 40mm
Weight	17.5 kg
Glass(Thickness / Material)	2.8mm / Tempered Glass with AR Coating
Backsheet(Color)	White
Frame(Material)	Anodized Aluminium
Junction Box(Protection Degree)	IP68 with 3 Bypass Diodes
Cables(Length)	1,000mm x 2EA
Connector(Type / Maker)	MC4 / MC

Certifications and Warranty

Certifications	IEC 61215-1/-1-1/2:2016, IEC 61730-1/2:2016
	UL 1703
	ISO 9001, ISO 14001, ISO 50001
	OHSAS 18001, PV CYCLE
Salt Mist Corrosion Test	IEC 61701:2012 Severity 6
Ammonia Corrosion Test	IEC 62716:2013
Module Fire Performance	Type 1
Fire Rating	Class C (UL 790)
Product Warranty	25 Years
Output Warranty of Pmax	Linear Warranty*

* 1) First year: 98% 2) After 1st year: 0.3% annual degradation 3) 25 years: 90.8%

Temperature Characteristics

NMOT*	[°C]	44 ± 3
Pmax	[%/°C]	-0.30
Voc	[%/°C]	-0.24
Isc	[%/°C]	0.037

* NMOT(Nominal Module Operating Temperature) : Irradiance 800 W/m², Ambient temperature 20 °C, Wind speed 1 m/s, Spectrum AM 1.5

Electrical Properties (NMOT)

Model		LG370Q1C-V5	LG365Q1C-V5
Maximum Power (Pmax)	[W]	279	275
MPP Voltage (Vmpp)	[V]	36.9	36.6
MPP Current (Impp)	[A]	7.55	7.51
Open Circuit Voltage (Voc)	[V]	40.3	40.2
Short Circuit Current (Isc)	[A]	8.71	8.70

I-V Curves

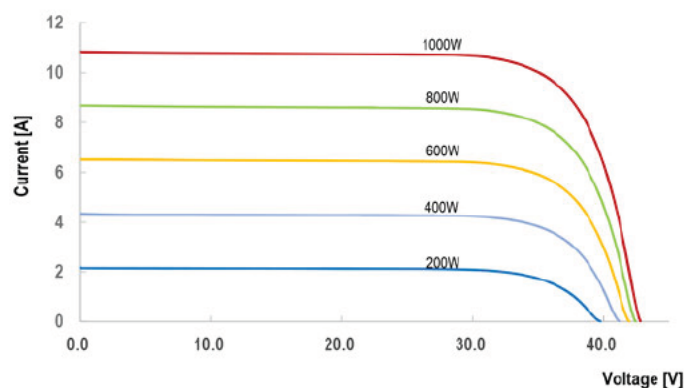

Electrical Properties (STC*)

Model		LG370Q1C-V5	LG365Q1C-V5
Maximum Power (Pmax)	[W]	370	365
MPP Voltage (Vmpp)	[V]	37.0	36.7
MPP Current (Impp)	[A]	10.01	9.95
Open Circuit Voltage (Voc, ±5%)	[V]	42.8	42.8
Short Circuit Current (Isc, ±5%)	[A]	10.82	10.80
Module Efficiency	[%]	21.4	21.1
Power Tolerance	[%]	0 ~ +3	

* STC (Standard Test Condition): Irradiance 1000 W/m², Cell Temperature 25 °C, AM 1.5

Operating Conditions

Operating Temperature	[°C]	-40 ~ +90
Maximum System Voltage	[V]	1,000
Maximum Series Fuse Rating	[A]	20
Mechanical Test Load(Front)	[Pa / psf]	5,400 / 113
Mechanical Test Load(Rear)	[Pa / psf]	4,000 / 83.5

* Test Load = Design x Safety Factor(1.5)

Packaging Configuration

Number of Modules Per Pallet	[EA]	25
Number of Modules Per 40ft HQ Container	[EA]	650
Packaging Box Dimensions (L x W x H)	[mm]	1,750 x 1,120 x 1,221
Packaging Box Gross Weight	[kg]	473

Dimensions (mm / inch)

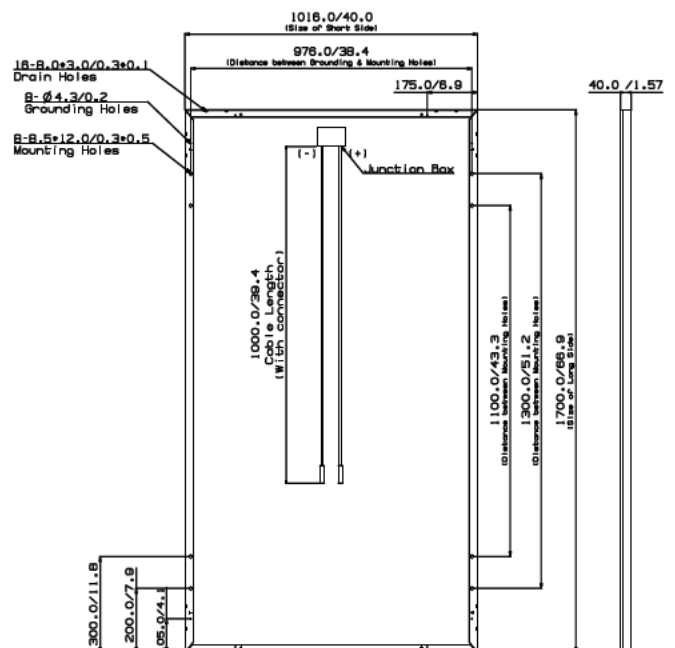

LG Electronics Inc.
Solar Business Division
2000 Millbrook Drive
Lincolnshire, IL 60069

www.lg-solar.com

Product specifications are subject to change without notice.
LG365-370Q1C-V_US_Ver01.pdf

© 2019 LG Electronics. All rights reserved.





LG NeON™ 2 Black

LG300N1K-G4

LG305N1K-G4

60 cell

LG's new module, LG NeON™ 2 Black, adopts Cello technology. Cello technology replaces 3 busbars with 12 thin wires to enhance power output and reliability. LG NeON™ 2 Black demonstrates LG's efforts to increase customer's values beyond efficiency. It features enhanced warranty, durability, performance under real environment, and aesthetic design suitable for roofs.



Enhanced Performance Warranty

LG NeON™ 2 Black has an enhanced performance warranty. The annual degradation has fallen from -0.7%/yr to -0.6%/yr. Even after 25 years, the cell guarantees 2.4%p more output than the previous LG NeON™ modules.



High Power Output

Compared with previous models, the LG NeON™ 2 Black has been designed to significantly enhance its output efficiency, thereby making it efficient even in limited space.



Aesthetic Roof

LG NeON™ 2 Black has been designed with aesthetics in mind; thinner wires that appear all black at a distance. The product may increase the value of a property with its modern design.



Outstanding Durability

With its newly reinforced frame design, LG has extended the warranty of the LG NeON™ 2 Black for an additional 2 years. Additionally, LG NeON™ 2 Black can endure a front load up to 6000 Pa, and a rear load up to 5400 Pa.

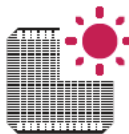

Better Performance on a Sunny Day

LG NeON™ 2 Black now performs better on sunny days thanks to its improved temperature coefficient.



Double-Sided Cell Structure

The rear of the cell used in LG NeON™ 2 Black will contribute to generation, just like the front; the light beam reflected from the rear of the module is reabsorbed to generate a great amount of additional power.

About LG Electronics

LG Electronics is a global player who has been committed to expanding its capacity, based on solar energy business as its future growth engine. We embarked on a solar energy source research program in 1985, supported by LG Group's rich experience in semi-conductor, LCD, chemistry, and materials industry. We successfully released first Mono X® series to the market in 2010, which were exported to 32 countries in the following 2 years, thereafter. In 2013, NeON™ (previously known as Mono X® NeON) & 2015 NeON2 with CELLO technology won "Intersolar Award", which proved LG is the leader of innovation in the industry.

Mechanical Properties

Cells	6 x 10
Cell Vendor	LG
Cell Type	Monocrystalline / N-type
Cell Dimensions	156.75 x 156.75 mm / 6 inches
# of Busbar	12 (Multi Wire Busbar)
Dimensions (L x W x H)	1640 x 1000 x 40 mm 64.57 x 39.37 x 1.57 inch
Front Load	6000 Pa / 125 psf
Rear Load	5400 Pa / 113 psf
Weight	17.0 ± 0.5 kg / 37.48 ± 1.1 lbs
Connector Type	MC4, MC4 Compatible, IP67
Junction Box	IP67 with 3 Bypass Diodes
Length of Cables	2 x 1000 mm / 2 x 39.37 inch
Glass	High Transmission Tempered Glass
Frame	Anodized Aluminum

Certifications and Warranty

Certifications	IEC 61215, IEC 61730-1/-2
	IEC 62716 (Ammonia Test)
	IEC 61701 (Salt Mist Corrosion Test)
	ISO 9001
	UL 1703
Module Fire Performance (USA)	Type 2 (UL 1703)
Fire Rating (for CANADA)	Class C (ULC/ORD C1703)
Product Warranty	12 years
Output Warranty of Pmax	Linear warranty*

* 1) 1st year: 98%, 2) After 2nd year: 0.6%p annual degradation, 3) 83.6% for 25 years

Temperature Characteristics

NOCT	45 ± 3 °C
Pmpp	-0.38 %/°C
Voc	-0.28 %/°C
Isc	0.03 %/°C

Characteristic Curves

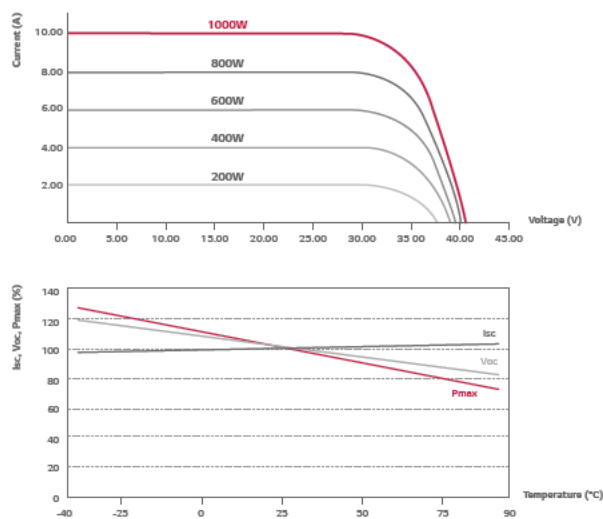

Electrical Properties (STC *)

Module Type	300 W	305 W
MPP Voltage (Vmpp)	32.5	32.9
MPP Current (Impp)	9.26	9.28
Open Circuit Voltage (Voc)	39.7	40.1
Short Circuit Current (Isc)	9.70	9.74
Module Efficiency (%)	18.3	18.6
Operating Temperature (°C)	-40 ~ +90	
Maximum System Voltage (V)	1000 (IEC/UL)	
Maximum Series Fuse Rating (A)	20	
Power Tolerance (%)	0 ~ +3	

* STC (Standard Test Condition): Irradiance 1000 W/m², Module Temperature 25 °C, AM 1.5

* The nameplate power output is measured and determined by LG Electronics at its sole and absolute discretion.

* The typical change in module efficiency at 200 W/m² in relation to 1000 W/m² is -3.0%.

Electrical Properties (NOCT*)

Module Type	300 W	305 W
Maximum Power (Pmax)	222	225
MPP Voltage (Vmpp)	30.1	30.4
MPP Current (Impp)	7.38	7.39
Open Circuit Voltage (Voc)	36.9	37.3
Short Circuit Current (Isc)	7.81	7.84

* NOCT (Nominal Operating Cell Temperature): Irradiance 800 W/m², ambient temperature 20 °C, wind speed 1 m/s

Dimensions (mm/in)

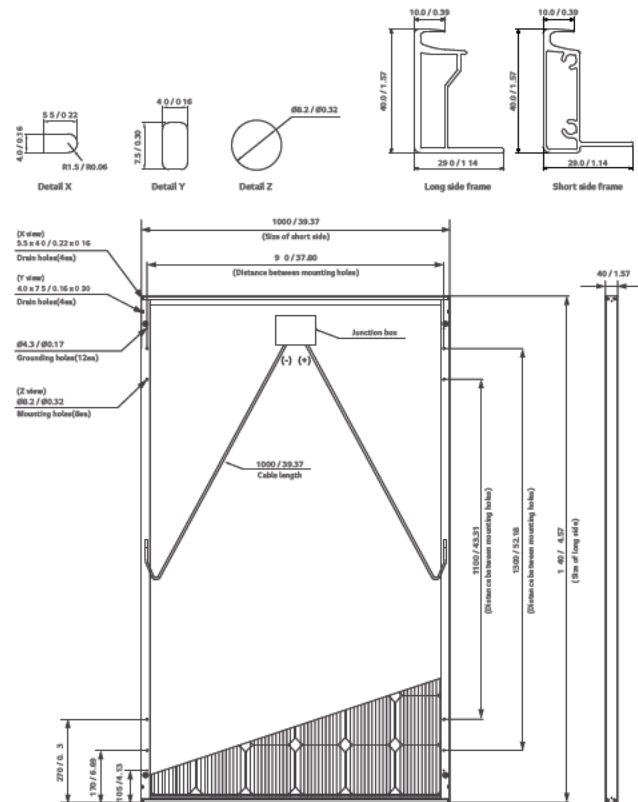

* The distance between the center of the mounting/grounding holes.



North America Solar Business Team
 LG Electronics U.S.A. Inc
 1000 Sylvan Ave, Englewood Cliffs, NJ 07632

Contact: lg.solar@lge.com
 www.lgsolarusa.com

Product specifications are subject to change without notice.
 DS-N2-60-K-G-F-EN-50427

Copyright © 2016 LG Electronics. All rights reserved.
 01/01/2016

Innovation for a Better Life



LG NeON[®] 2 Black

LG325N1K-A5 | LG320N1K-A5 | LG315N1K-A5



60

325W | 320W | 315W

The LG NeON[®] 2 is LG's best-selling solar module. The NeON[®] 2 received the acclaimed 2015 Intersolar AWARD for featuring LG's Cello Technology, which increases power output and reliability and makes the NeON[®] 2 one of the most powerful and versatile modules on the market.

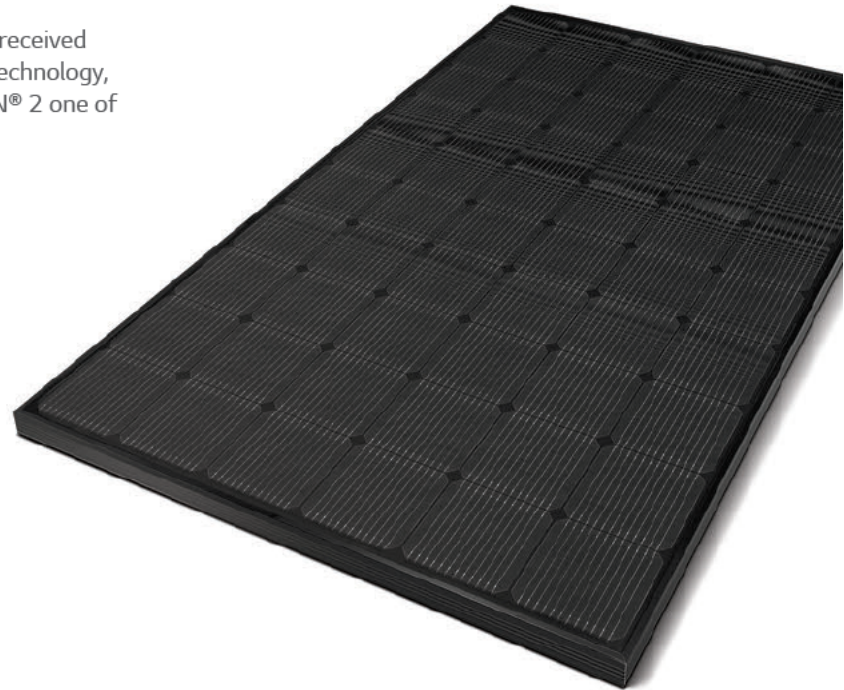

Feature



Enhanced Performance Warranty

LG NeON[®] 2 has an enhanced performance warranty. The annual degradation has fallen from -0.6 %/yr to -0.5 %/yr. Even after 25 years, the cell guarantees 2.4 % more output than the previous LG NeON[®] 2 modules.



High Power Output

Compared with previous models, the LG NeON[®] 2 Black has been designed to significantly enhance its output efficiency, thereby making it efficient even in limited space.



Roof Aesthetics

LG NeON[®] 2 Black has been designed with aesthetics in mind, using thinner wires that appear all black at a distance.



Outstanding Durability

With its newly reinforced frame design, LG has extended the warranty of the NeON[®] 2 from 15 years to 25 years, including labor. In addition, LG NeON[®] 2 can endure a front load up to 6000 Pa, and a rear load up to 5400 Pa.



Improved Performance on Sunny Days

LG NeON[®] 2 Black now performs better on sunny days, thanks to its improved temperature coefficient.



Near Zero LID (Light Induced Degradation)

The n-type cells used in LG NeON[®] 2 have almost no boron. This leads to less LID (Light Induced Degradation) right after installation.

About LG Electronics

LG Electronics is a global big player, committed to expanding its operations with the solar market. The company first embarked on a solar energy source research program in 1985, supported by LG Group's vast experience in the semi-conductor, LCD, chemistry and materials industries. In 2010, LG Solar successfully released its first MonoX[®] series to the market, which is now available in 32 countries. The NeON[®] (previous MonoX[®] NeON), NeON[®] 2, NeON[®] 2 BiFacial won the "Intersolar AWARD" in 2013, 2015 and 2016, which demonstrates LG Solar's lead, innovation and commitment to the industry.



LG NeON[®] 2 Black

LG325N1K-A5 | LG320N1K-A5 | LG315N1K-A5

Mechanical Properties

Cells	6 x 10
Cell Vendor	LG
Cell Type	Monocrystalline / N-type
Cell Dimensions	161.7 x 161.7 mm / 6 inches
# of Busbar	12 (Multi Wire Busbar)
Dimensions (L x W x H)	1,686 x 1,016 x 40 mm 66.38 x 40 x 1.57 in
Front Load	6,000Pa / 125 psf*
Rear Load	5,400Pa / 113 psf*
Weight	18 kg / 39.68 lb
Connector Type	MC4 (MC), PV-JM601A(JMTHY)
Junction Box	IP68 with 3 Bypass Diodes
Cables	1,000 mm x 2 ea / 39.37 in x 2 ea
Glass	Tempered Glass with AR Coating
Frame	Anodized Aluminium

* Please refer to the installation manual for the details.

Certifications and Warranty

Certifications	IEC 61215, IEC 61730-1/-2
	UL 1703
	IEC 61701 (Salt mist corrosion test)
	IEC 62716 (Ammonia corrosion test)
	ISO 9001
Module Fire Performance	Type 2 (UL 1703)
Fire Rating	Class C (ULC/ORD C 1703, IEC 61730)
Product Warranty	25 Years
Output Warranty of Pmax	Linear Warranty*

* 1) 1st year: 98%, 2) After 1st year: 0.5%p annual degradation, 3) 86% for 25 years

Temperature Characteristics

NOCT	[°C]	45 ± 3
Pmax	[%/°C]	-0.37
Voc	[%/°C]	-0.27
Isc	[%/°C]	0.03

Characteristic Curves

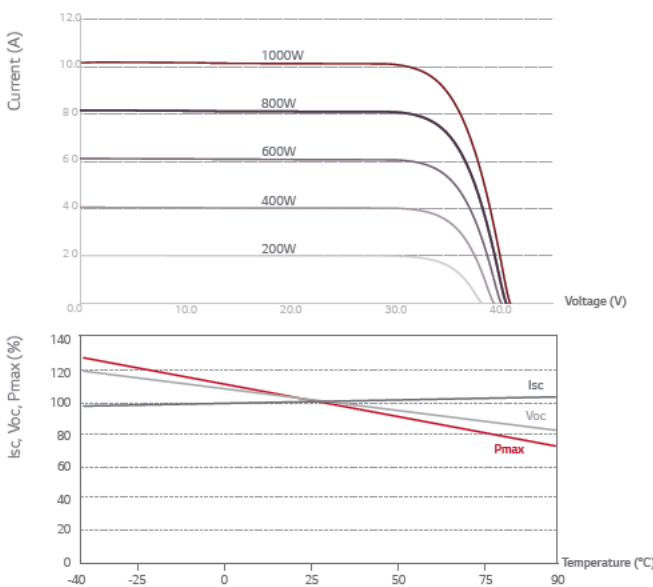

Electrical Properties (STC*)

Model		LG325N1K-A5	LG320N1K-A5	LG315N1K-A5
Maximum Power (Pmax)	[W]	325	320	315
MPP Voltage (Vmpp)	[V]	33.7	33.3	32.9
MPP Current (Impp)	[A]	9.65	9.62	9.58
Open Circuit Voltage (Voc)	[V]	40.9	40.8	40.7
Short Circuit Current (Isc)	[A]	10.23	10.19	10.15
Module Efficiency	[%]	19.0	18.7	18.4
Operating Temperature	[°C]	-40 ~ +90		
Maximum System Voltage	[V]	1000 (UL / IEC)		
Maximum Series Fuse Rating	[A]	20		
Power Tolerance	[%]	0 ~ +3		

* STC (Standard Test Condition): Irradiance 1000 W/m², cell temperature 25 °C, AM 1.5

The nameplate power output is measured and determined by LG Electronics at its sole and absolute discretion.

Electrical Properties (NOCT*)

Model		LG325N1K-A5	LG320N1K-A5	LG315N1K-A5
Maximum Power (Pmax)	[W]	240	236	232
MPP Voltage (Vmpp)	[V]	31.2	30.8	30.4
MPP Current (Impp)	[A]	7.69	7.67	7.63
Open Circuit Voltage (Voc)	[V]	38.1	38.0	37.9
Short Circuit Current (Isc)	[A]	8.23	8.20	8.17

* NOCT (Nominal Operating Cell Temperature): Irradiance 800 W/m², ambient temperature 20 °C, wind speed 1 m/s

Dimensions (mm / inch)

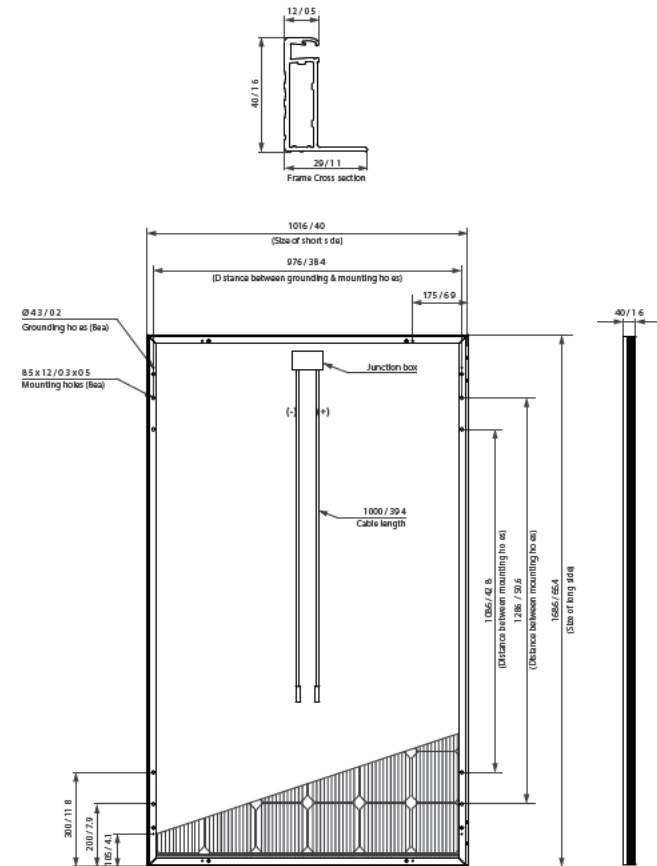

* The distance between the center of the mounting/grounding holes.



North America Solar Business Team
 LG Electronics U.S.A. Inc
 1000 Sylvan Ave, Englewood Cliffs, NJ 07632
 Contact: lg.solar@lge.com
 www.lgsolarusa.com

Product specifications are subject to change without notice.
 DS-N5-60-K-G-F-EN-80308

© 2018 LG Electronics. All rights reserved.



Power Optimizer Specifications – P300 / P400

	P300	P400	
INPUT			
Rated Input DC Power ⁽¹⁾	300	400	W
Absolute Maximum Input Voltage (Voc)	48	80	Vdc
MPPT Operating Range	8 - 48	8 - 80	Vdc
Maximum Short Circuit Current (Isc) of connected PV Module	10		Adc
Maximum DC Input Current	12.5		%
Maximum Efficiency	99.5		%
Weighted Efficiency	98.8		
Overvoltage Category	II		
OUTPUT DURING OPERATION (POWER OPTIMIZER CONNECTED TO OPERATING INVERTER)			
Maximum Output Current	15		Adc
Maximum Output Voltage	60		Vdc
OUTPUT DURING STANDBY (POWER OPTIMIZER DISCONNECTED FROM INVERTER OR INVERTER OFF)			
Safety Output Voltage per Power Optimizer	1		Vdc
STANDARD COMPLIANCE			
EMC	FCC Part15 Class B, IEC61000-6-2, EC61000-6-3		
Safety	IEC62109-1 (class II safety), UL1741		
Material	UL-94 (5-VA), UV Resistant		
RoHS	Yes		
INSTALLATION SPECIFICATIONS			
Maximum Allowed System Voltage	1000		Vdc
Dimensions (WxLxH)	128 x 152 x 27.5 / 5 x 5.97 x 1.08	141 x 212 x 35 / 5.55 x 8.34 x 1.37	mm / in
Weight (including cables)	770 / 1.7	930 / 2.05	g / lb
Input Connector	MC4 compatible		
Output Wire Type / Connector	Double Insulated; Amphenol H4		
Output Wire Length	0.95 / 3.0	1.2 / 3.9	m / ft
Operating Temperature Range	-40 - +85 / -40 - +185		C / °F
Protection Rating	IP68 / NEMA6P		
Relative Humidity	0 - 100		%

⁽¹⁾ Rated STC power of the module. Module of up to +5% power tolerances allowed

PV SYSTEM DESIGN USING SOLAREEDGE INVERTER	SINGLE PHASE	THREE PHASE 208V	THREE PHASE	
Minimum String Length (Power Optimizers)	8	10	18	
Maximum String Length (Power Optimizers)	25	25	50	
Maximum Power per String	5250	6000	12750	W
Parallel Strings of Different Lengths or Orientations	Yes			

P300

(Dimensions in mm)

P400

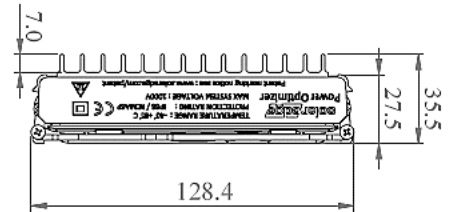
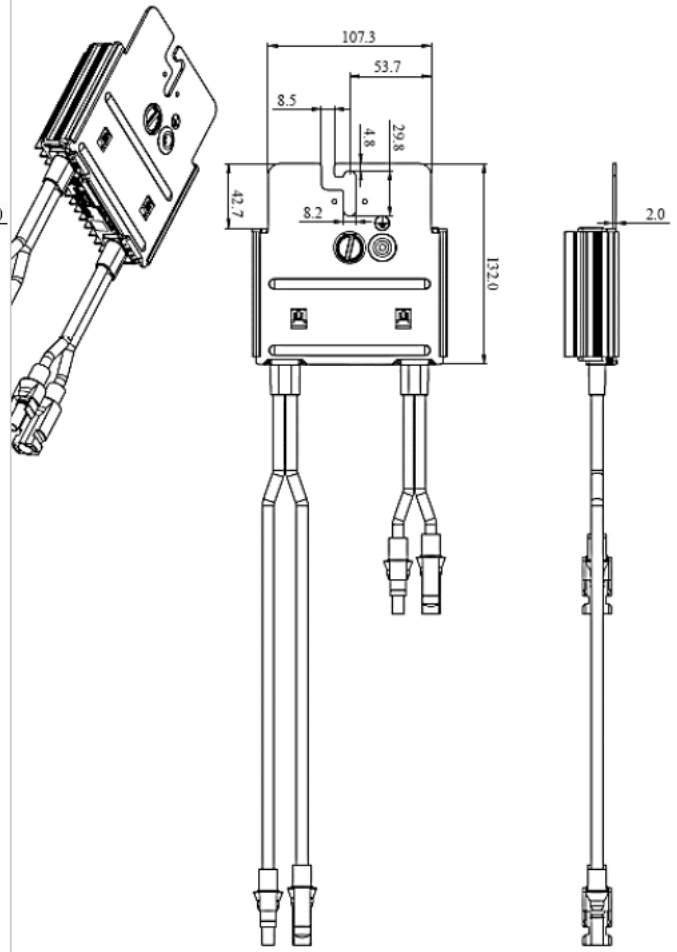
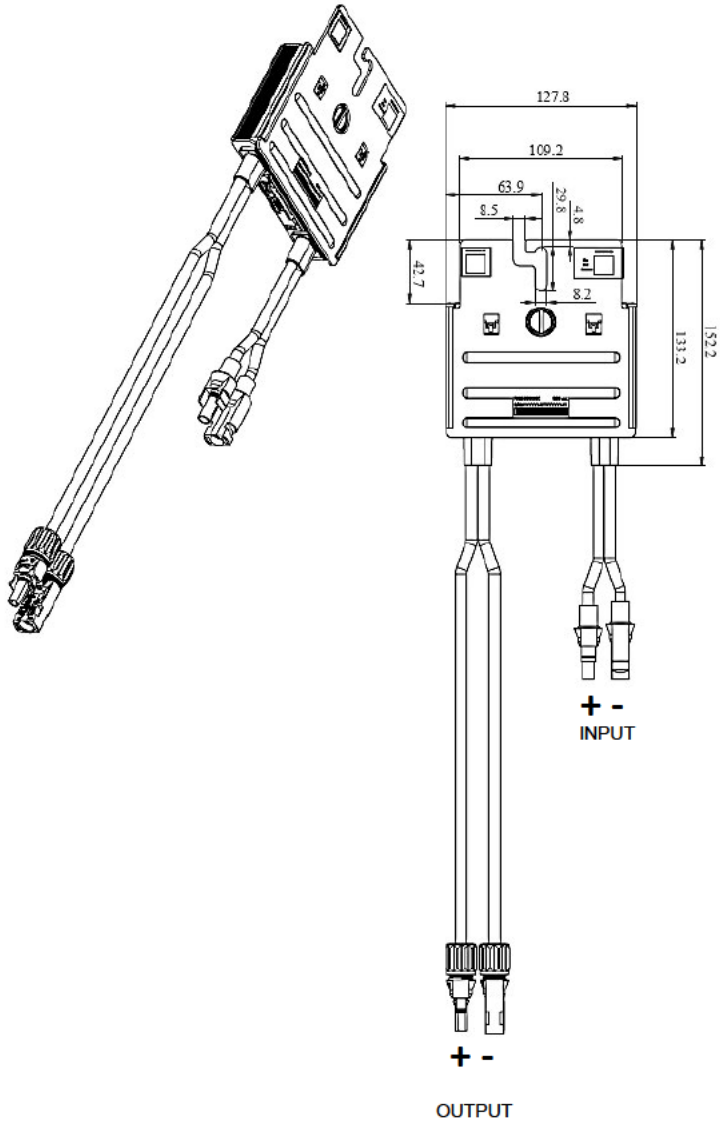

MAN-01-00173-1.0

solar**edge**

Single Phase Inverter with HD-Wave Technology for North America

SE3000H-US / SE3800H-US / SE5000H-US /
SE6000H-US / SE7600H-US / SE10000H-US

INVERTERS



Optimized installation with HD-Wave technology

- Specifically designed to work with power optimizers
- Record-breaking efficiency
- Fixed voltage inverter for longer strings
- Integrated arc fault protection and rapid shutdown for NEC 2014 and 2017, per article 690.11 and 690.12
- UL1741 SA certified, for CPUC Rule 21 grid compliance
- Extremely small
- High reliability without any electrolytic capacitors
- Built-in module-level monitoring
- Outdoor and indoor installation
- Optional: Revenue grade data, ANSI C12.20 Class 0.5 (0.5% accuracy)





Single Phase Inverter

with HD-Wave Technology for North America

SE3000H-US / SE3800H-US / SE5000H-US /
SE6000H-US/ SE7600H-US / SE10000H-US

	SE3000H-US	SE3800H-US	SE5000H-US	SE6000H-US	SE7600H-US	SE10000H-US	
OUTPUT							
Rated AC Power Output	3000	3800 @ 240V 3300 @ 208V	5000	6000 @ 240V 5000 @ 208V	7600	10000	VA
Max. AC Power Output	3000	3800 @ 240V 3300 @ 208V	5000	6000 @ 240V 5000 @ 208V	7600	10000	VA
AC Output Voltage Min.-Nom.-Max. (183 - 208 - 229)	-	✓	-	✓	-	-	Vac
AC Output Voltage Min.-Nom.-Max. (211 - 240 - 264)	✓	✓	✓	✓	✓	✓	Vac
AC Frequency (Nominal)				59.3 - 60 - 60.5 ⁽¹⁾			Hz
Maximum Continuous Output Current 208V	-	16	-	24	-	-	A
Maximum Continuous Output Current @240V	12.5	16	21	25	32	42	A
GFDI Threshold				1			A
Utility Monitoring, Islanding Protection, Country Configurable Thresholds				Yes			
INPUT							
Maximum DC Power @240V	4650	5900	7750	9300	11800	15500	W
Maximum DC Power @208V	-	5100	-	7750	-	-	
Transformer-less, Ungrounded				Yes			
Maximum Input Voltage				480			Vdc
Nominal DC Input Voltage				380	400		Vdc
Maximum Input Current 208V				9	13.5		
Maximum Input Current @240V	8.5	10.5	13.5	16.5	20	27	Adc
Max. Input Short Circuit Current				45			Adc
Reverse-Polarity Protection				Yes			
Ground-Fault Isolation Detection				600k Ω Sensitivity			
Maximum Inverter Efficiency	99			99.2			%
CEC Weighted Efficiency				99			%
Nighttime Power Consumption				< 2.5			W
ADDITIONAL FEATURES							
Supported Communication Interfaces	RS485, Ethernet, ZigBee (optional), Cellular (optional)						
Revenue Grade Data, ANSI C12.20	Optional ⁽²⁾						
Rapid Shutdown - NEC 2014 and 2017 690.12	Automatic Rapid Shutdown upon AC Grid Disconnect						
STANDARD COMPLIANCE							
Safety	UL1741, UL1741 SA, UL1699B, CSA C22.2, Canadian AFCI according to T.I.L. M-07						
Grid Connection Standards	IEEE1547, Rule 21, Rule 14 (HI)						
Emissions	FCC Part 15 Class B						
INSTALLATION SPECIFICATIONS							
AC Output Conduit Size / AWG Range	3/4" minimum / 20-4 AWG						
DC Input Conduit Size / # of Strings / AWG Range	3/4" minimum / 1-2 strings / 14-6 AWG					3/4" minimum / 1-3 strings / 14-6 AWG	
Dimensions with Safety Switch (HxWxD)	17.7 x 14.6 x 6.8 / 450 x 370 x 174					21.3 x 14.6 x 7.3 / 540 x 370 x 185	in / mm
Weight with Safety Switch	22 / 10	25.1 / 11.4	26.2 / 11.9	38.8 / 17.6			lb / kg
Noise	< 25			<50			dBA
Cooling	Natural Convection			Natural convection			
Operating Temperature Range	-13 to +140 / -25 to +60 ⁽³⁾ (-40°F / -40°C option) ⁽⁴⁾						
Protection Rating	NEMA 3R (Inverter with Safety Switch)						

⁽¹⁾ For other regional settings please contact SolarEdge support

⁽²⁾ Revenue grade inverter P/N: SExxxxH-US000NNC2

⁽³⁾ For power de-rating information refer to: <https://www.solaredge.com/sites/default/files/se-temperature-derating-note-na.pdf>

⁽⁴⁾ -40 version P/N: SExxxxH-US000NNU4





SolarEdge Single Phase Inverters

For North America

SE3000A-US / SE3800A-US / SE5000A-US / SE6000A-US /
SE7600A-US / SE10000A-US / SE11400A-US



INVERTERS

The best choice for SolarEdge enabled systems

- Integrated arc fault protection (Type 1) for NEC 2011 690.11 compliance
- Superior efficiency (98%)
- Small, lightweight and easy to install on provided bracket
- Built-in module-level monitoring
- Internet connection through Ethernet or Wireless
- Outdoor and indoor installation
- Fixed voltage inverter, DC/AC conversion only
- Pre-assembled Safety Switch for faster installation
- Optional – revenue grade data, ANSI C12.1



Single Phase Inverters for North America

SE3000A-US / SE3800A-US / SE5000A-US / SE6000A-US /
SE7600A-US / SE10000A-US / SE11400A-US

	SE3000A-US	SE3800A-US	SE5000A-US	SE6000A-US	SE7600A-US	SE10000A-US	SE11400A-US		
OUTPUT									
Nominal AC Power Output	3000	3800	5000	6000	7600	9980 @ 208V 10000 @ 240V	11400	VA	
Max. AC Power Output	3300	4150	5400 @ 208V 5450 @ 240V	6000	8350	10800 @ 208V 10950 @ 240V	12000	VA	
AC Output Voltage Min.-Nom.-Max. ⁽¹⁾ 183 - 208 - 229 Vac	-	-	✓	-	-	✓	-		
AC Output Voltage Min.-Nom.-Max. ⁽¹⁾ 211 - 240 - 264 Vac	✓	✓	✓	✓	✓	✓	✓		
AC Frequency Min.-Nom.-Max. ⁽¹⁾	59.3 - 60 - 60.5 (with HI country setting 57 - 60 - 60.5)							Hz	
Max. Continuous Output Current	12.5	16	24 @ 208V 21 @ 240V	25	32	48 @ 208V 42 @ 240V	47.5	A	
GFDI Threshold	1							A	
Utility Monitoring, Islanding Protection, Country Configurable Thresholds	Yes							Yes	
INPUT									
Maximum DC Power (STC)	4050	5100	6750	8100	10250	13500	15350	W	
Transformer-less, Ungrounded	Yes								
Max. Input Voltage	500							Vdc	
Nom. DC Input Voltage	325 @ 208V / 350 @ 240V							Vdc	
Max. Input Current ⁽²⁾	9.5	13	16.5 @ 208V 15.5 @ 240V	18	23	33 @ 208V 30.5 @ 240V	34.5	Adc	
Max. Input Short Circuit Current	45							Adc	
Reverse-Polarity Protection	Yes								
Ground-Fault Isolation Detection	600k Ω Sensitivity								
Maximum Inverter Efficiency	97.7	98.2	98.3 97.5 @ 208V	98.3	98	98 97 @ 208V	98	%	
CEC Weighted Efficiency	97.5	98	98 @ 240V	97.5	97.5	97.5 @ 240V	97.5	%	
Nighttime Power Consumption	< 2.5							< 4	W
ADDITIONAL FEATURES									
Supported Communication Interfaces	RS485, RS232, Ethernet, ZigBee (optional)								
Revenue Grade Data, ANSI C12.1	Optional ⁽³⁾								
Rapid Shutdown – NEC 2014 690.12	Functionality enabled when SolarEdge rapid shutdown kit is installed ⁽⁴⁾								
STANDARD COMPLIANCE									
Safety	UL1741, UL1699B, UL1998, CSA 22.2								
Grid Connection Standards	IEEE1547								
Emissions	FCC part15 class B								
INSTALLATION SPECIFICATIONS									
AC output conduit size / AWG range	3/4" minimum / 16-6 AWG					3/4" minimum / 8-3 AWG			
DC input conduit size / # of strings / AWG range	3/4" minimum / 1-2 strings / 16-6 AWG					3/4" minimum / 1-2 strings / 14-6 AWG			
Dimensions with Safety Switch (HxWxD)	30.5 x 12.5 x 7.2 / 775 x 315 x 184					30.5 x 12.5 x 10.5 / 775 x 315 x 260			
Weight with Safety Switch	51.2 / 23.2		54.7 / 24.7			88.4 / 40.1		in / mm lb / kg	
Cooling	Natural Convection				Natural convection and internal fan (user replaceable)	Fans (user replaceable)			
Noise	< 25				< 50				dBa
Min.-Max. Operating Temperature Range	-13 to +140 / -25 to +60 (-40 to +60 version available ⁽⁵⁾)							°F / °C	
Protection Rating	NEMA 3R								

⁽¹⁾ For other regional settings please contact SolarEdge support.

⁽²⁾ A higher current source may be used; the inverter will limit its input current to the values stated.

⁽³⁾ Revenue grade inverter P/N: SExxxxA-US000NNR2 (for 7600W inverter SE7600A-US002NNR2).

⁽⁴⁾ Rapid shutdown kit P/N: SE1000-RSD-S1.

⁽⁵⁾ -40 version P/N: SExxxxA-US000NNU4 (for 7600W inverter SE7600A-US002NNU4).



RoHS

EXHIBIT 5

[Redacted]

[Redacted]

[Redacted]

[Redacted]

From: Melton, Timothy [Redacted]
Sent: Monday, April 19, 2021 2:02 PM
To: Clayton Salchi [Redacted]
Subject: RE: Steve Ricketts Expansion NM Agreement - LG&E

If this installation is completed in Q3, the whole net metering (old and new) would be under the new guidelines. Everything must be installed and operational prior to effective change date. Customer can do maintenance on existing

panels (replacing a bad panel) or add batteries after the effective date and not lose grandfathering.

Please contact me if you have questions.

Timothy A. Melton

Manager | Customer Commitment | LG&E and KU

[REDACTED], Louisville, KY 40202

M: [REDACTED] | O: [REDACTED] | F: [REDACTED]

[REDACTED]

From: Clayton Salchi [REDACTED]
Sent: Monday, April 19, 2021 1:02 PM
To: Melton, Timothy [REDACTED]
Subject: RE: Steve Ricketts Expansion NM Agreement - LG&E

EXTERNAL email. STOP and THINK before responding, clicking on links, or opening attachments.

Thanks Tim. To confirm, LG&E will honor the customer's expansion in Q3 under current net metering guidelines?

Clayton

From: Melton, Timothy [REDACTED]
Sent: Monday, April 19, 2021 10:20 AM
To: Clayton Salchi [REDACTED]; Design sesre [REDACTED]
Subject: FW: Steve Ricketts Expansion NM Agreement - LG&E

LG&E engineering has approved the expansion net metering and solar proposal for Steve Ricketts. Please notify me after additional panels are installed. Thanks

From: nm_engineering [REDACTED]
Sent: Monday, April 19, 2021 10:01 AM
To: Melton, Timothy [REDACTED]; nm_engineering [REDACTED]
Subject: RE: Steve Ricketts Expansion NM Agreement - LG&E

Tim,

This application has been reviewed by distribution engineering and is approved.

Zach

From: Melton, Timothy [REDACTED]
Sent: Friday, April 09, 2021 8:32 AM
To: nm_engineering [REDACTED]
Subject: Steve Ricketts Expansion NM Agreement - LG&E

Customer has 10.02 kW DC existing and is adding 4.44 kW DC for a total of 14.46 kW.

Please review and approve. thanks

From: Clayton Salchi [REDACTED]
Sent: Thursday, April 08, 2021 4:03 PM
To: Melton, Timothy [REDACTED]
Cc: Matt Partymiller [REDACTED]; Steve Ricketts [REDACTED]
Subject: Solar Energy Solutions - Net Metering Application

EXTERNAL email. STOP and THINK before responding, clicking on links, or opening attachments.

Hello Tim,

I would like to submit a net metering application for a mutual customer, Steve Ricketts. He is planning an expansion for his existing system. Please see attached for our application as well as plans for the new and existing equipment.

Thanks,

Clayton

Engineering Department

Solar Energy Solutions

----- The information contained in this transmission is intended only for the person or entity to which it is directly addressed or copied. It may contain material of confidential and/or private nature. Any review, retransmission, dissemination or other use of, or taking of any action in reliance upon, this information by persons or

entities other than the intended recipient is not allowed. If you received this message and the information contained therein by error, please contact the sender and delete the material from your/any storage medium.

----- The information contained in this transmission is intended only for the person or entity to which it is directly addressed or copied. It may contain material of confidential and/or private nature. Any review, retransmission, dissemination or other use of, or taking of any action in reliance upon, this information by persons or entities other than the intended recipient is not allowed. If you received this message and the information contained therein by error, please contact the sender and delete the material from your/any storage medium.

Steve Ricketts
214 Kennedy Avenue
Louisville, KENTUCKY 40206

*Honorable David Edward Spenard
Strobo Barkley PLLC
239 South 5th Street
Ste 917
Louisville, KENTUCKY 40202

*Randal A. Strobo
Strobo Barkley PLLC
239 South 5th Street
Ste 917
Louisville, KENTUCKY 40202

*Louisville Gas and Electric Company
220 W. Main Street
P. O. Box 32010
Louisville, KY 40232-2010