



Matthew G. Bevin  
Governor

Charles G. Snavely  
Secretary  
Energy and Environment Cabinet

Commonwealth of Kentucky  
**Public Service Commission**  
211 Sower Blvd.  
P.O. Box 615  
Frankfort, Kentucky 40602-0615  
Telephone: (502) 564-3940  
Fax: (502) 564-3460  
psc.ky.gov

Michael J. Schmitt  
Chairman

Robert Cicero  
Vice Chairman

Talina R. Mathews  
Commissioner

August 28, 2019

## PARTIES OF RECORD

Re: Case No. 2019-00154  
Electronic Application of Kentucky Power Company for a Certificate of Public Convenience and Necessity to Perform Upgrade, Replacement, and Installation Work at its Existing Substation Facilities in Perry and Leslie Counties, Kentucky

Attached is a copy of the memorandum which is being filed in the record of the above referenced case. If you have any comments you would like to make regarding the contents of the informal conference memorandum, please do so within five days of receipt of this letter. If you have any questions, please contact Quang Nguyen, Staff Attorney, at 502/782-2586.

Sincerely,

A handwritten signature in blue ink that reads "Gwen R. Pinson".

Gwen R. Pinson  
Executive Director

QN/ch

Attachments

## INTRA-AGENCY MEMORANDUM

### KENTUCKY PUBLIC SERVICE COMMISSION

**TO:** Case File – Case No. 2019-00154

**FROM:** Quang D. Nguyen, Assistant General Counsel 

**DATE:** August 28, 2019

**RE:** Informal Conference of July 30, 2019

Pursuant to an Order issued on July 24, 2019, an informal conference (IC) was held at Kentucky Power Company's (Kentucky Power) Hazard Substation located at 1400 East Main Street, Hazard, Kentucky, on July 30, 2019. The IC was held at the request of Kentucky Power to allow Commission Staff and the Office of the Attorney General view the general condition of the Hazard Substation and the various components that are proposed to be upgraded and replaced. In attendance were representatives from Kentucky Power, Commission Staff, and the Office of the Attorney General. The attendance sheet for IC is attached to this memo.

After brief introductions and safety protocols of the substation area, Kentucky Power representatives provided an overview of the current configuration of the Hazard Substation and described the upgrades and replacements that are the subject of Kentucky Power's application in this matter. A slide presentation provided by Kentucky Power is attached to this memo. After a question and answer session, the attendees then proceeded outside to examine and inspect the substation area along with the various facilities and physical assets that are outdated and proposed to be replaced by Kentucky Power. The attendees then travelled to and examined a nearby substation that was relatively newer as compared to the Hazard Substation and included transmission assets that were of more recent vintage.

There being no further discussion, the IC was then adjourned.

Attachments

COMMONWEALTH OF KENTUCKY  
BEFORE THE PUBLIC SERVICE COMMISSION

In the Matter of:

ELECTRONIC APPLICATION OF KENTUCKY	)	
POWER COMPANY FOR A CERTIFICATE OF	)	
PUBLIC CONVENIENCE AND NECESSITY TO	)	CASE NO.
PERFORM UPGRADE, REPLACEMENT, AND	)	2019-00154
INSTALLATION WORK AT ITS EXISTING	)	
SUBSTATION FACILITIES IN PERRY AND LESLIE	)	
COUNTIES, KENTUCKY	)	

**Informal Conference – July 30, 2019**

Please sign in:

NAME	REPRESENTING
------	--------------

Jim Livers	PSC – Financial Analysis
Jeff Moore	PSC – Division of Inspections
Quang Nguyen	PSC – Office of General Counsel
Justin McNeil	Office of the Attorney General
Mike Smith	AEP Protection & Control
Mike Hollifield	AEP Protection & Control
Kamran Ali	AEP Transmission Planning
Will Burkett	AEP Transmission Planning
Mike Spurlock	AEP Transmission Station Equipment Standards
Mike Skidmore	AEP Transmission Station Equipment Standards
Jomar Perez-Ramos	AEP Transmission Asset Performance
Barry Jones	AEP Transmission Field Services
John Paul Blankenship	AEP Equipment Specialist
Laurie Spears	AEP Transmission Asset Strategy
Mike Lasslo	Kentucky Power Distribution Reliability Manager
Andrew Strader	AEP Protection & Control Engineering Design Standards
Scott Dimpfl	AEP Station Design Standards
Christen M. Blend	AEP Senior Counsel
Mark R. Overstreet	Stites & Harbison PLLC (outside counsel)
John W. Pollom	Stites & Harbison PLLC (outside counsel)

# Baseline vs. Supplemental

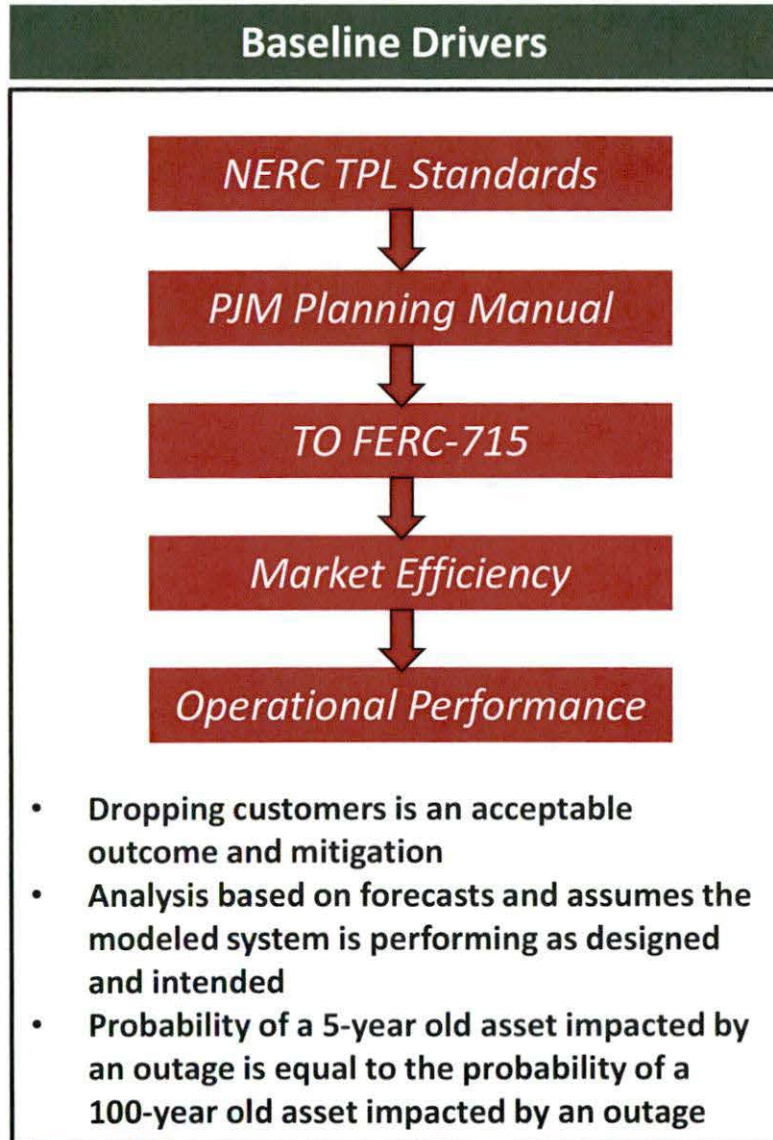

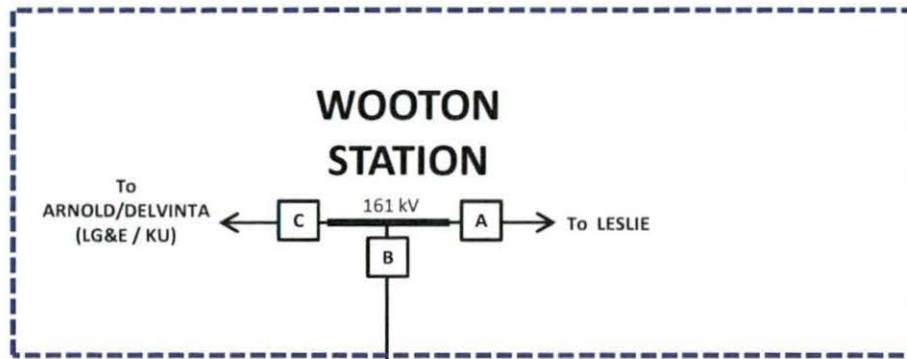

~6.5 miles of 161 kV line

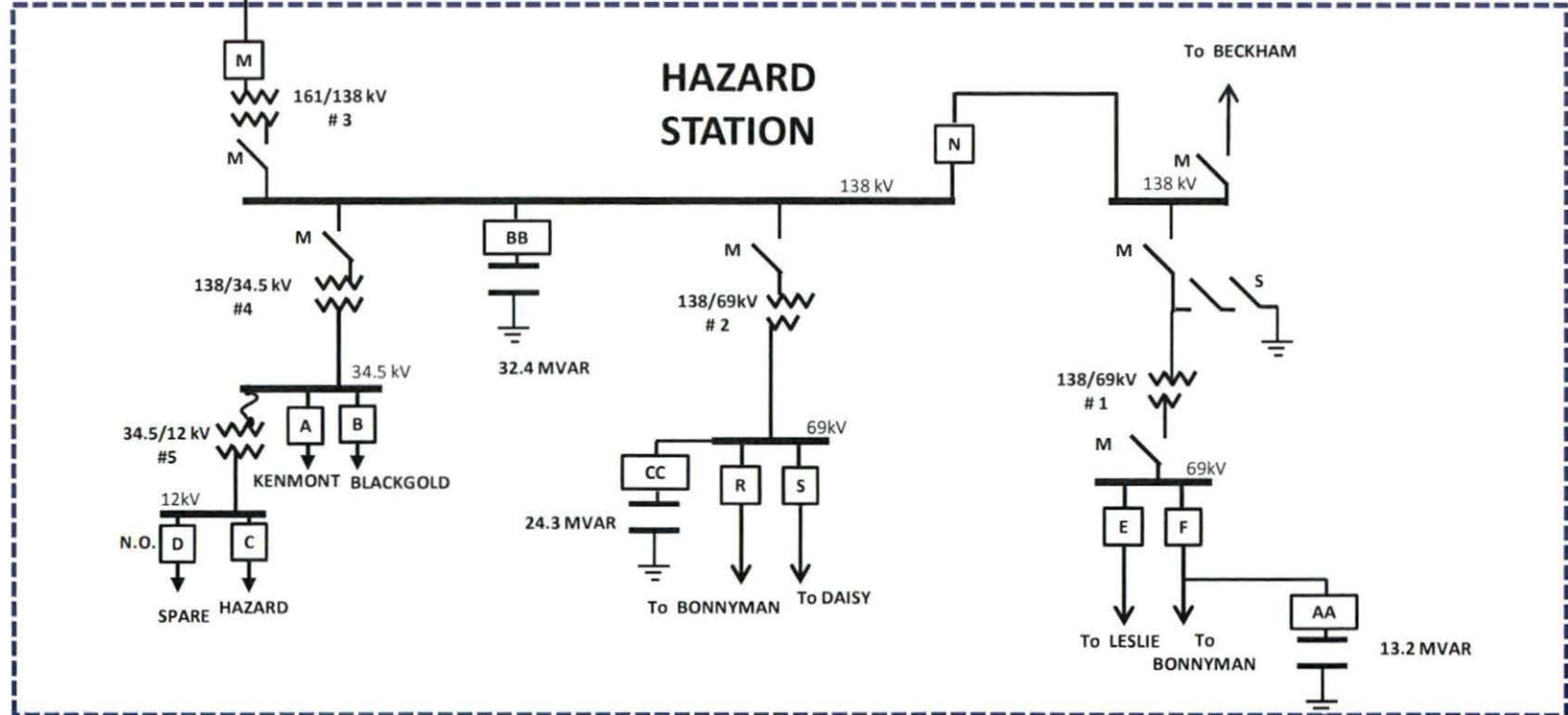
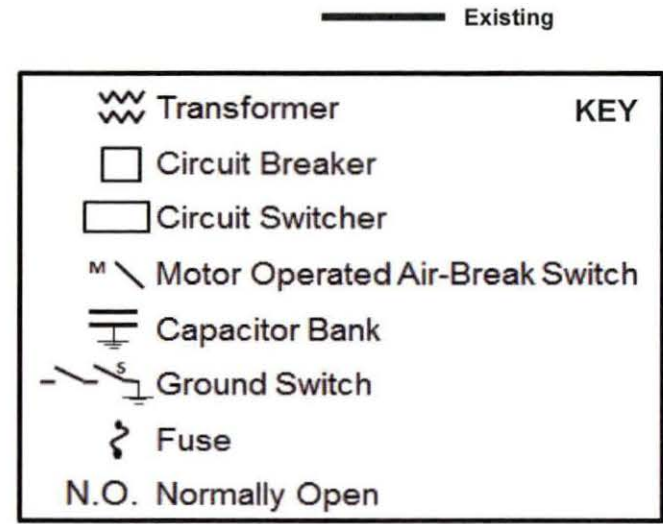

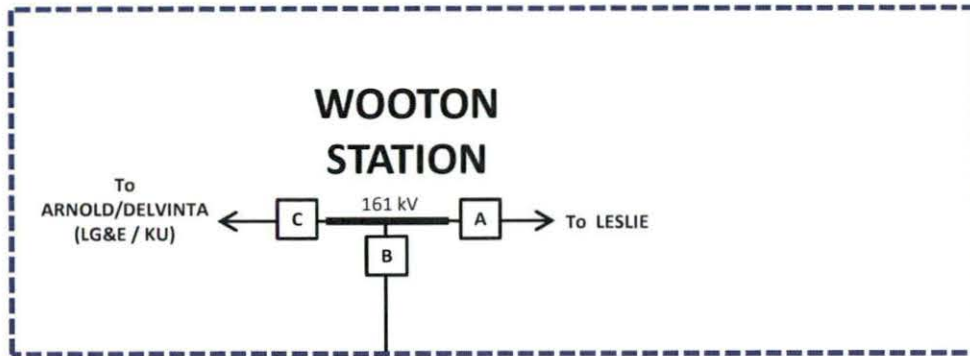

— Existing  
 — Proposed

~6.5 miles of 161 kV line

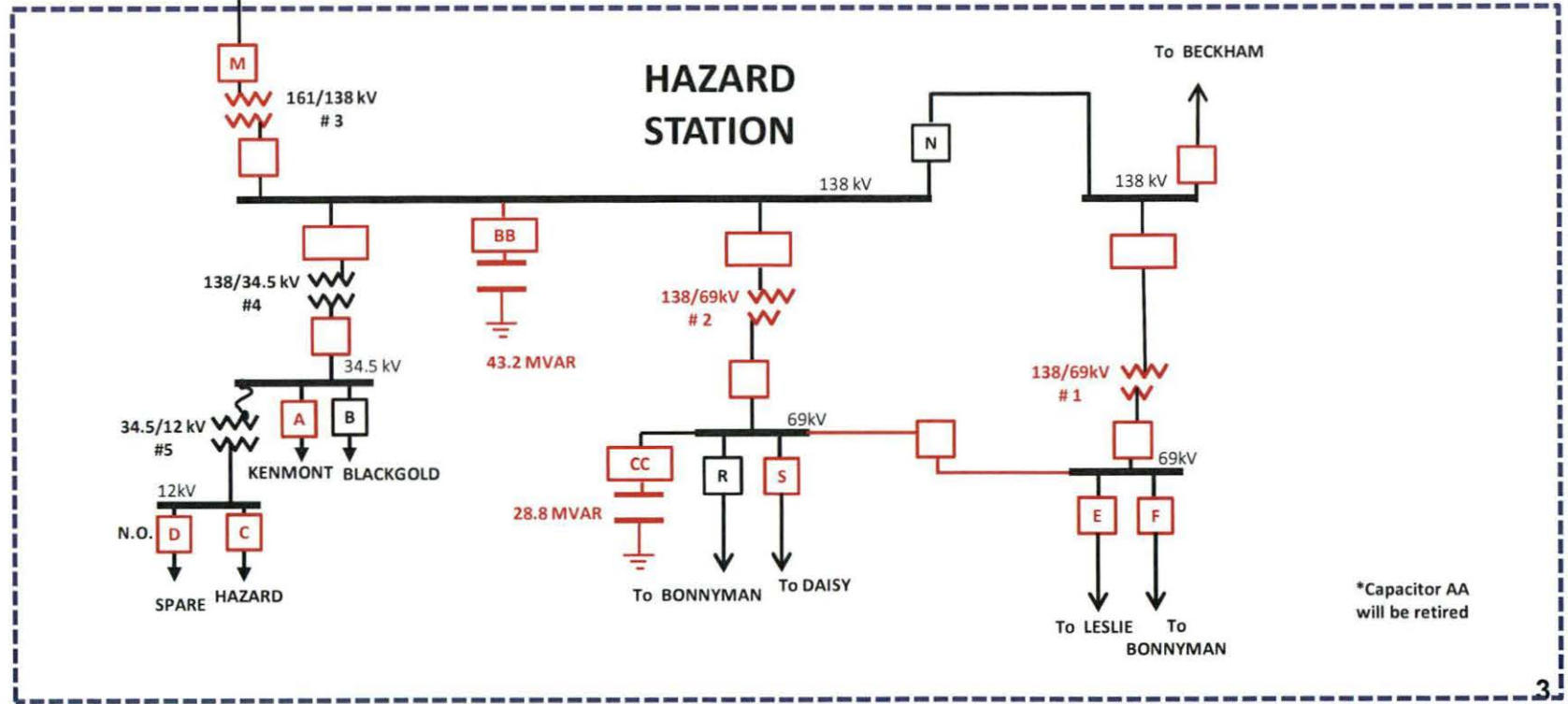

\*Christen M Blend  
American Electric Power Service Corporation  
1 Riverside Plaza, 29th Floor  
Post Office Box 16631  
Columbus, OHIO 43216

\*Honorable Mark R Overstreet  
Attorney at Law  
Stites & Harbison  
421 West Main Street  
P. O. Box 634  
Frankfort, KENTUCKY 40602-0634

\*John W. Pollom  
Stites & Harbison  
421 West Main Street  
P. O. Box 634  
Frankfort, KENTUCKY 40602-0634

\*Rebecca W Goodman  
Assistant Attorney General  
Office of the Attorney General Office of Rate  
700 Capitol Avenue  
Suite 20  
Frankfort, KENTUCKY 40601-8204

\*Justin M. McNeil  
Office of the Attorney General Office of Rate  
700 Capitol Avenue  
Suite 20  
Frankfort, KENTUCKY 40601-8204

\*Kent Chandler  
Assistant Attorney General  
Office of the Attorney General Office of Rate  
700 Capitol Avenue  
Suite 20  
Frankfort, KENTUCKY 40601-8204

\*Kentucky Power Company  
855 Central Avenue, Suite 200  
Ashland, KY 41101

\*Katie M Glass  
Stites & Harbison  
421 West Main Street  
P. O. Box 634  
Frankfort, KENTUCKY 40602-0634

\*Larry Cook  
Assistant Attorney General  
Office of the Attorney General Office of Rate  
700 Capitol Avenue  
Suite 20  
Frankfort, KENTUCKY 40601-8204