

COMMONWEALTH OF KENTUCKY  
BEFORE THE PUBLIC SERVICE COMMISSION

RECEIVED

DEC 15 2009

PUBLIC SERVICE  
COMMISSION

In the matter of:

THE APPLICATION OF EAST KENTUCKY NETWORK )  
LIMITED LIABILITY COMPANY FOR THE ISSUANCE )  
OF A CERTIFICATE OF PUBLIC CONVENIENCE AND ) CASE No 2009-00424  
NECESSITY TO CONSTRUCT A TOWER IN KNOTT )  
COUNTY, KENTUCKY).

East Kentucky Network, LLC, d/b/a Appalachian Wireless, was granted authorization to provide cellular service in the KY-10 Cellular Market Area (CMA452) by the Federal Communications Commission (FCC). FCC license is included as Exhibit 1. East Kentucky Network, LLC merger documents were filed with the Commission on February 2, 2001 in Case # 2001-022.

In an effort to improve service in Knott County, East Kentucky Network, LLC pursuant to KRS 278.020 Subsection 1 and 807 KAR 5:001 Section 9 is seeking the Commission's approval to construct a 180 foot self-supporting tower on a tract of land approximately 0.5 miles north of Cordia in Knott County, Kentucky (37°17'03.68"N 83°06'46.14"W). A map and detailed directions to the site can be found in Exhibit 8.

Exhibit 2 is a list of all Property owners or residents according to the property valuation administrator's record who reside or own property within 500 feet of the proposed tower in accordance with the Public Valuation Administrator. No other properties are contiguous with East Kentucky Network's property.

Pursuant to 807 KAR 5:063 Section 1 (1)(L) and Section 1(1)(n)(1) all affected property owners according to the property valuation administrator's record who reside or own property within 500 feet of the proposed Tower were notified by certified mail return receipt requested of East Kentucky Network, LLC's proposed construction and informed of their right to intervene.

They were given the docket number under which this application is filed. Enclosed in Exhibit 2 is a copy of that notification.

Knott County has no formal local planning unit. In absence of this unit the Knott County Judge Executive's office was notified by certified mail, return receipt requested of East Kentucky Network Limited Liability Company's proposal and informed of their right to intervene. They were given the docket number under which this application is filed. Enclosed in Exhibit 3 is a copy of that notification.

Notice of the location of the proposed construction was published in the Troublesome Creek Time's November 12<sup>th</sup> & 19<sup>th</sup> weekly editions. Enclosed is a copy of that notice in Exhibit 3. The Troublesome Creek Times is the newspaper with the largest circulation in Knott County.

A geologist was employed to determine soil and rock types and to ascertain the distance to solid bedrock. The geotechnical report is enclosed as Exhibit 4.

A copy of the tower design information is enclosed as Exhibit 5. The proposed tower has been designed by engineers at Allstate Tower, Inc. and will be constructed under their supervision. Their qualifications are evidenced in Exhibit 5 by the seal and signature of the registered professional engineer responsible for this project.

The tower will be erected by S & S Tower Services of St. Albans, West Virginia. S & S Tower Services has vast experience in the erection of communications towers.

FAA and Kentucky Airport Zoning Commission applications are included as Exhibit 6.

No Federal Communications Commission approval is required prior to construction of this facility. Once service is established from this tower we must immediately notify the Federal Communications Commission of its operation. Prior approval is needed only if the proposed facility increases the size of the cellular geographic service area. This cell site will not expand the cellular geographic service area.

East Kentucky Network, LLC will finance the subject Construction with earned surplus in its General Fund.

Estimated Cost of Construction	\$ 350,000.00
Annual Operation Expense of Tower	\$ 12,500.00

Two notice signs meeting the requirements prescribed by 807 KAR 5:063, Section 1(2), measuring at least two (2) feet in height and four (4) feet in width and containing all required language in letters of required height, have been posted, one at a visible location on the proposed site and one on the nearest public road. The two signs were posted on November 10, 2009 and will remain posted for at least two weeks after filing of this application as specified.

Enclosed in Exhibit 9 is a copy of East Kentucky Network LLC's deed and easement with deed description to the site.

The proposed construction site is on a very rugged mountaintop some feet from the nearest structure. Prior to construction the site was wooded.

Due to the steep hillside surrounding the proposed site, the property in close proximity is unsuitable for any type of development. East Kentucky Network LLC's operation will not affect the use of nearby land nor its value. No more suitable site exists in the area. A copy of the search area map is enclosed in Exhibit 8. No other tower capable of supporting East Kentucky Network LLC's load exists in the general area; therefore, there is no opportunity for co-location of our facilities with anyone else.

Enclosed, and filed as Exhibit 10 is a survey of the proposed tower site signed by a Kentucky registered professional engineer.

Exhibit 12 contains a vertical sketch of the tower supplied by Coleman Engineering.

1	FCC License
2	Copies of Cell Site Notices to Land Owners
3	Notification of County Judge Executive and Newspaper Advertisement
4	Universal Soil Bearing Analysis
5	Tower Design
6	FAA & Kentucky Airport Zoning Commission Applications
7	Audited Financial Statements
8	Driving Directions from County Court House and Map to Suitable Scale
9	Deed & Easement for Proposed Site
10	Survey of Site Signed/Sealed by Professional Engineer Registered in State of Kentucky
11	Site Survey Map with Property Owners identified in Accordance with PVA of County
12	Vertical Profile Sketch of Proposed Tower





## Universal Licensing System

FCC > WTB > ULS > Online Systems > License Search

[FCC Site Map](#)

ULS License

### Cellular License - KNKN809 - East Kentucky Network, LLC [?](#) HELP

#### d/b/a Appalachian Wireless

[New Search](#) [Refine Search](#) [Return to Results](#) [Printable Page](#) [Reference Copy](#) [Map License](#)

**MAIN** ADMIN LOCATIONS

Call Sign KNKN809 Radio Service CL - Cellular  
 Status Active Auth Type Regular

**Market**

Market CMA452 - Kentucky 10 - Powell Channel Block B [\(View Frequencies\)](#)  
 Submarket 0 Phase 2

**Dates**

Grant 08/28/2001 Expiration 10/01/2011  
 Effective 11/11/2009 Cancellation

**Five Year Buildout Date**

10/17/1996

**Control Points**

**1** US Route 23, FLOYD, Harold, KY  
 P: (606)478-2355

**Licensee**

FRN 0001786607 Type Limited Liability Company  
[\(View Ownership Filing\)](#)

**Licensee**

East Kentucky Network, LLC d/b/a Appalachian Wireless P:(606)477-2355  
 101 Technology Trail F:(606)874-7551  
 Ivel, KY 41642  
 ATTN Gerald Robinette, Manager

**Contact**

Lukas, Nace, Gutierrez & Sachs, LLP P:(703)584-8665  
 Pamela L. Gist Esq F:(703)584-8695  
 8300 Greensboro Drive E:pgist@fcclaw.com  
 McLean, VA 22102

**Ownership and Qualifications**

Radio Service Type Mobile

Regulatory Status Common Carrier Interconnected Yes

**Alien Ownership**

The Applicant answered "No" to each of the [Alien Ownership](#) questions.

**Basic Qualifications**

The Applicant answered "No" to each of the [Basic Qualification](#) questions.

**Demographics**

Race

Ethnicity

Gender

**ULS Help**

[ULS Glossary](#) - [FAQ](#) - [Online Help](#) - [Technical Support](#) - [Licensing Support](#)

**ULS Online Systems**

[CORES](#) - [ULS Online Filing](#) - [License Search](#) - [Application Search](#) - [Archive License Search](#)

**About ULS**

[Privacy Statement](#) - [About ULS](#) - [ULS Home](#)

**Basic Search**

By Call Sign

=

**SEARCH**

[FCC](#) | [Wireless](#) | [ULS](#) | [CORES](#)

[Help](#) | [Tech Support](#)

Federal Communications Commission  
445 12th Street SW  
Washington, DC 20554

Phone: 1-877-480-3201  
TTY: 1-717-338-2824  
[Submit Help Request](#)





**EXHIBIT II: LIST OF PROPERTY OWNERS:**

**Statement Pursuant to Section 1 (1) (I) 807 KAR 5:063**

**Section 1 (1)(I) 1.** The following is a list of every property owner who according to property valuation administrator's records, owns property within 500 feet of the proposed tower and each have been: notified by certified mail, return receipt requested, of the proposed construction,

**Section 1 (1)(I) 2.** Every person listed below who, according to the property valuation administrator's records, owns property within 500 feet of the proposed tower has been: Given the Commission docket number under which the application will be processed: and

**Section 1 (1)(I) 3.** Every person listed below who, according to property valuation administrator's records, owns property within 500 feet of the proposed tower has been: Informed of his right to request intervention.

LIST OF PROPERTY OWNERS

Mattie Singleton  
Howard & Georgia Owens  
5011 Lotts Crk Rd  
Hazard, KY 41701

Howard & Georgia Owens  
39 Clear Fork Road  
Hazard, KY 41701

Toyna Engle & Tim Cody  
292 Clear Fork Road  
Lotts Creek, KY 41701

Alvah & Diana Skaggs  
35 Spring Ave  
Hazard, KY 41701

Roger Eversole  
5411 Lotts Creek Road  
Hazard, KY 41701

Sterling & Sherry Martin  
P.O. Box 403  
Bulan, KY 41722

**EXHIBIT II: LIST OF PROPERTY OWNERS: (cont.)**

Authur Gayheart Heirs  
C/O Gina Gayheart  
P.O. Box 484  
Bulan, KY 41722

Oscar & Sybilm Grigsby  
263 Clear Fork Road  
Lotts Creek, KY 41701

Lloyd & Jetta Gayheart  
Rt 2 Box 170 Clear Fk Rd  
Hazard, KY 41701

Amy Allen  
141 Clear Fork Road  
Lotts Creek, KY 41701

Dexter & Alma Little  
233 Clear Fork Road  
Hazard, KY 41701

William Feltner  
309 Clear Fork Road  
Hazard, KY 41701

EAST KENTUCKY NETWORK  
101 TECHNOLOGY TRAIL  
LEVEL, KY 41642  
PHONE: (606) 874-7550  
FAX: (606) 874-7551  
EMAIL: INFO@EKN.COM  
WEBSITE: WWW.EKN.COM



VIA: U.S. CERTIFIED MAIL

PUBLIC NOTICE

November 10, 2009

Mattie Singleton, Howard & Georgia Owens  
5011 Lotts Crk Rd  
Hazard, KY 41701

RE: Public Notice-Public Service Commission of Kentucky (Case No. 2009-00424)

East Kentucky Network, LLC d/b/a Appalachian Wireless has applied to the Public Service Commission of Kentucky for a Certificate of Public Convenience and Necessity to construct and operate a new facility to provide cellular telecommunications service in Knott County. The facility will include a 180 foot self-supporting tower with attached antennas extending upwards, and an equipment shelter located on a tract of land approximately .50 miles north of Cordia in Knott County, Kentucky. A map showing the location of the proposed new facility is enclosed. This notice is being sent to you because you may own property or reside within a 500' radius of the proposed tower or within a 200' radius of the proposed or existing access road.

The Commission invites your comments regarding the proposed construction. You also have the right to intervene in this matter. The Commission must receive your initial communication within 20 days of the date of this letter as shown above.

Your comments and request for intervention should be addressed to: Executive Director's Office, Public Service Commission of Kentucky, P.O. Box 615, Frankfort, KY 40602. Please refer to Case No. 2009-00424 in your correspondence.

Sincerely,

A handwritten signature in cursive script that reads "Lynn Haney".

Lynn Haney  
Staff Accountant

Enclosure 1

EAST KENTUCKY NETWORK  
101 TECHNOLOGY TRAIL  
IVEL, KY 41642  
PHONE: (606) 874-7550  
FAX: (606) 874-7551  
EMAIL: INFO@EKN.COM  
WEBSITE: WWW.EKN.COM



VIA: U.S. CERTIFIED MAIL

PUBLIC NOTICE

November 10, 2009

Howard & Georgia Owens  
39 Clear Fork Road  
Hazard, KY 41701

RE: Public Notice-Public Service Commission of Kentucky (Case No. 2009-00424)

East Kentucky Network, LLC d/b/a Appalachian Wireless has applied to the Public Service Commission of Kentucky for a Certificate of Public Convenience and Necessity to construct and operate a new facility to provide cellular telecommunications service in Knott County. The facility will include a 180 foot self-supporting tower with attached antennas extending upwards, and an equipment shelter located on a tract of land approximately .50 miles north of Cordia in Knott County, Kentucky. A map showing the location of the proposed new facility is enclosed. This notice is being sent to you because you may own property or reside within a 500' radius of the proposed tower or within a 200' radius of the proposed or existing access road.

The Commission invites your comments regarding the proposed construction. You also have the right to intervene in this matter. The Commission must receive your initial communication within 20 days of the date of this letter as shown above.

Your comments and request for intervention should be addressed to: Executive Director's Office, Public Service Commission of Kentucky, P.O. Box 615, Frankfort, KY 40602. Please refer to Case No. 2009-00424 in your correspondence.

Sincerely,

A handwritten signature in cursive script that reads "Lynn Haney".

Lynn Haney  
Staff Accountant

Enclosure 1

EAST KENTUCKY NETWORK  
101 TECHNOLOGY TRAIL  
IVEL, KY 41642  
PHONE: (606) 874-7550  
FAX: (606) 874-7551  
EMAIL: INFO@EKN.COM  
WEBSITE: WWW.EKN.COM



VIA: U.S. CERTIFIED MAIL

PUBLIC NOTICE

November 10, 2009

Toyna Engle & Tim Cody  
292 Clear Fork Road  
Lotts Creek, KY 41701

RE: Public Notice-Public Service Commission of Kentucky (Case No. 2009-00424)

East Kentucky Network, LLC d/b/a Appalachian Wireless has applied to the Public Service Commission of Kentucky for a Certificate of Public Convenience and Necessity to construct and operate a new facility to provide cellular telecommunications service in Knott County. The facility will include a 180 foot self-supporting tower with attached antennas extending upwards, and an equipment shelter located on a tract of land approximately .50 miles north of Cordia in Knott County, Kentucky. A map showing the location of the proposed new facility is enclosed. This notice is being sent to you because you may own property or reside within a 500' radius of the proposed tower or within a 200' radius of the proposed or existing access road.

The Commission invites your comments regarding the proposed construction. You also have the right to intervene in this matter. The Commission must receive your initial communication within 20 days of the date of this letter as shown above.

Your comments and request for intervention should be addressed to: Executive Director's Office, Public Service Commission of Kentucky, P.O. Box 615, Frankfort, KY 40602. Please refer to Case No. 2009-00424 in your correspondence.

Sincerely,

A handwritten signature in cursive script that reads "Lynn Haney".

Lynn Haney  
Staff Accountant

Enclosure 1

EAST KENTUCKY NETWORK  
101 TECHNOLOGY TRAIL  
IVEL, KY 41642  
PHONE: (606) 874-7550  
FAX: (606) 874-7551  
EMAIL: INFO@EKN.COM  
WEBSITE: WWW.EKN.COM



VIA: U.S. CERTIFIED MAIL

PUBLIC NOTICE

November 10, 2009

Alvah & Diana Skaggs  
35 Spring Ave  
Hazard, KY 41701

RE: Public Notice-Public Service Commission of Kentucky (Case No. 2009-00424)

East Kentucky Network, LLC d/b/a Appalachian Wireless has applied to the Public Service Commission of Kentucky for a Certificate of Public Convenience and Necessity to construct and operate a new facility to provide cellular telecommunications service in Knott County. The facility will include a 180 foot self-supporting tower with attached antennas extending upwards, and an equipment shelter located on a tract of land approximately .50 miles north of Cordia in Knott County, Kentucky. A map showing the location of the proposed new facility is enclosed. This notice is being sent to you because you may own property or reside within a 500' radius of the proposed tower or within a 200' radius of the proposed or existing access road.

The Commission invites your comments regarding the proposed construction. You also have the right to intervene in this matter. The Commission must receive your initial communication within 20 days of the date of this letter as shown above.

Your comments and request for intervention should be addressed to: Executive Director's Office, Public Service Commission of Kentucky, P.O. Box 615, Frankfort, KY 40602. Please refer to Case No. 2009-00424 in your correspondence.

Sincerely,

A handwritten signature in cursive script that reads "Lynn Haney".

Lynn Haney  
Staff Accountant

Enclosure 1

EAST KENTUCKY NETWORK  
101 TECHNOLOGY TRAIL  
IVEL, KY 41642  
PHONE: (606) 874-7550  
FAX: (606) 874-7551  
EMAIL: INFO@EKN.COM  
WEBSITE: WWW.EKN.COM



VIA: U.S. CERTIFIED MAIL

PUBLIC NOTICE

November 10, 2009

Roger Eversole  
5411 Lotts Creek Road  
Hazard, KY 41701

RE: Public Notice-Public Service Commission of Kentucky (Case No. 2009-00424)

East Kentucky Network, LLC d/b/a Appalachian Wireless has applied to the Public Service Commission of Kentucky for a Certificate of Public Convenience and Necessity to construct and operate a new facility to provide cellular telecommunications service in Knott County. The facility will include a 180 foot self-supporting tower with attached antennas extending upwards, and an equipment shelter located on a tract of land approximately .50 miles north of Cordia in Knott County, Kentucky. A map showing the location of the proposed new facility is enclosed. This notice is being sent to you because you may own property or reside within a 500' radius of the proposed tower or within a 200' radius of the proposed or existing access road.

The Commission invites your comments regarding the proposed construction. You also have the right to intervene in this matter. The Commission must receive your initial communication within 20 days of the date of this letter as shown above.

Your comments and request for intervention should be addressed to: Executive Director's Office, Public Service Commission of Kentucky, P.O. Box 615, Frankfort, KY 40602. Please refer to Case No. 2009-00424 in your correspondence.

Sincerely,

A handwritten signature in cursive script that reads "Lynn Haney".

Lynn Haney  
Staff Accountant

Enclosure 1

EAST KENTUCKY NETWORK  
101 TECHNOLOGY TRAIL  
IVEL, KY 41642  
PHONE: (606) 874-7550  
FAX: (606) 874-7551  
EMAIL: INFO@EKN.COM  
WEBSITE: WWW.EKN.COM



VIA: U.S. CERTIFIED MAIL

PUBLIC NOTICE

November 10, 2009

Sterling & Sherry Martin  
P.O. Box 403  
Bulan, KY 41722

RE: Public Notice-Public Service Commission of Kentucky (Case No. 2009-00424)

East Kentucky Network, LLC d/b/a Appalachian Wireless has applied to the Public Service Commission of Kentucky for a Certificate of Public Convenience and Necessity to construct and operate a new facility to provide cellular telecommunications service in Knott County. The facility will include a 180 foot self-supporting tower with attached antennas extending upwards, and an equipment shelter located on a tract of land approximately .50 miles north of Cordia in Knott County, Kentucky. A map showing the location of the proposed new facility is enclosed. This notice is being sent to you because you may own property or reside within a 500' radius of the proposed tower or within a 200' radius of the proposed or existing access road.

The Commission invites your comments regarding the proposed construction. You also have the right to intervene in this matter. The Commission must receive your initial communication within 20 days of the date of this letter as shown above.

Your comments and request for intervention should be addressed to: Executive Director's Office, Public Service Commission of Kentucky, P.O. Box 615, Frankfort, KY 40602. Please refer to Case No. 2009-00424 in your correspondence.

Sincerely,

A handwritten signature in cursive script that reads "Lynn Haney".

Lynn Haney  
Staff Accountant

Enclosure 1



EAST KENTUCKY NETWORK  
101 TECHNOLOGY TRAIL  
IVEL, KY 41642  
PHONE: (606) 874-7550  
FAX: (606) 874-7551  
EMAIL: INFO@EKN.COM  
WEBSITE: WWW.EKN.COM



VIA: U.S. CERTIFIED MAIL

PUBLIC NOTICE

November 10, 2009

Authur Gayheart Heirs  
C/O Gina Gayheart  
P.O. Box 484  
Bulan, KY 41722

RE: Public Notice-Public Service Commission of Kentucky (Case No. 2009-00424)

East Kentucky Network, LLC d/b/a Appalachian Wireless has applied to the Public Service Commission of Kentucky for a Certificate of Public Convenience and Necessity to construct and operate a new facility to provide cellular telecommunications service in Knott County. The facility will include a 180 foot self-supporting tower with attached antennas extending upwards, and an equipment shelter located on a tract of land approximately .50 miles north of Cordia in Knott County, Kentucky. A map showing the location of the proposed new facility is enclosed. This notice is being sent to you because you may own property or reside within a 500' radius of the proposed tower or within a 200' radius of the proposed or existing access road.

The Commission invites your comments regarding the proposed construction. You also have the right to intervene in this matter. The Commission must receive your initial communication within 20 days of the date of this letter as shown above.

Your comments and request for intervention should be addressed to: Executive Director's Office, Public Service Commission of Kentucky, P.O. Box 615, Frankfort, KY 40602. Please refer to Case No. 2009-00424 in your correspondence.

Sincerely,

A handwritten signature in cursive script that reads "Lynn Haney".

Lynn Haney  
Staff Accountant

Enclosure 1

EAST KENTUCKY NETWORK  
101 TECHNOLOGY TRAIL  
IVEL, KY 41642  
PHONE: (606) 874-7550  
FAX: (606) 874-7551  
EMAIL: INFO@EKN.COM  
WEBSITE: WWW.EKN.COM



VIA: U.S. CERTIFIED MAIL

PUBLIC NOTICE

November 10, 2009

Oscar & Sybil Grigsby  
263 Clear Fork Rd  
Lotts Creek, KY 41701

RE: Public Notice-Public Service Commission of Kentucky (Case No. 2009-00424)

East Kentucky Network, LLC d/b/a Appalachian Wireless has applied to the Public Service Commission of Kentucky for a Certificate of Public Convenience and Necessity to construct and operate a new facility to provide cellular telecommunications service in Knott County. The facility will include a 180 foot self-supporting tower with attached antennas extending upwards, and an equipment shelter located on a tract of land approximately .50 miles north of Cordia in Knott County, Kentucky. A map showing the location of the proposed new facility is enclosed. This notice is being sent to you because you may own property or reside within a 500' radius of the proposed tower or within a 200' radius of the proposed or existing access road.

The Commission invites your comments regarding the proposed construction. You also have the right to intervene in this matter. The Commission must receive your initial communication within 20 days of the date of this letter as shown above.

Your comments and request for intervention should be addressed to: Executive Director's Office, Public Service Commission of Kentucky, P.O. Box 615, Frankfort, KY 40602. Please refer to Case No. 2009-00424 in your correspondence.

Sincerely,

A handwritten signature in cursive script that reads "Lynn Haney".

Lynn Haney  
Staff Accountant

Enclosure 1

EAST KENTUCKY NETWORK  
101 TECHNOLOGY TRAIL  
IVEL, KY 41642  
PHONE: (606) 874-7550  
FAX: (606) 874-7551  
EMAIL: INFO@EKN.COM  
WEBSITE: WWW.EKN.COM



VIA: U.S. CERTIFIED MAIL

PUBLIC NOTICE

November 10, 2009

Lloyd & Jetta Gayheart  
Rt 2 Box 170 Clear Fork Rd  
Hazard, KY 41701

RE: Public Notice-Public Service Commission of Kentucky (Case No. 2009-00424)

East Kentucky Network, LLC d/b/a Appalachian Wireless has applied to the Public Service Commission of Kentucky for a Certificate of Public Convenience and Necessity to construct and operate a new facility to provide cellular telecommunications service in Knott County. The facility will include a 180 foot self-supporting tower with attached antennas extending upwards, and an equipment shelter located on a tract of land approximately .50 miles north of Cordia in Knott County, Kentucky. A map showing the location of the proposed new facility is enclosed. This notice is being sent to you because you may own property or reside within a 500' radius of the proposed tower or within a 200' radius of the proposed or existing access road.

The Commission invites your comments regarding the proposed construction. You also have the right to intervene in this matter. The Commission must receive your initial communication within 20 days of the date of this letter as shown above.

Your comments and request for intervention should be addressed to: Executive Director's Office, Public Service Commission of Kentucky, P.O. Box 615, Frankfort, KY 40602. Please refer to Case No. 2009-00424 in your correspondence.

Sincerely,

A handwritten signature in cursive script that reads "Lynn Haney".

Lynn Haney  
Staff Accountant

Enclosure 1

EAST KENTUCKY NETWORK  
101 TECHNOLOGY TRAIL  
LEVEL, KY 41642  
PHONE: (606) 874-7550  
FAX: (606) 874-7551  
: INFO@EKN.COM  
v. ...SITE: WWW.EKN.COM



VIA: U.S. CERTIFIED MAIL

PUBLIC NOTICE

November 10, 2009

Amy Allen  
141 Clear Fork Road  
Lotts Creek, KY 41701

RE: Public Notice-Public Service Commission of Kentucky (Case No. 2009-00424)

East Kentucky Network, LLC d/b/a Appalachian Wireless has applied to the Public Service Commission of Kentucky for a Certificate of Public Convenience and Necessity to construct and operate a new facility to provide cellular telecommunications service in Knott County. The facility will include a 180 foot self-supporting tower with attached antennas extending upwards, and an equipment shelter located on a tract of land approximately .50 miles north of Cordia in Knott County, Kentucky. A map showing the location of the proposed new facility is enclosed. This notice is being sent to you because you may own property or reside within a 500' radius of the proposed tower or within a 200' radius of the proposed or existing access road.

The Commission invites your comments regarding the proposed construction. You also have the right to intervene in this matter. The Commission must receive your initial communication within 20 days of the date of this letter as shown above.

Your comments and request for intervention should be addressed to: Executive Director's Office, Public Service Commission of Kentucky, P.O. Box 615, Frankfort, KY 40602. Please refer to Case No. 2009-00424 in your correspondence.

Sincerely,

A handwritten signature in cursive script that reads "Lynn Haney".

Lynn Haney  
Staff Accountant

Enclosure 1

EAST KENTUCKY NETWORK  
101 TECHNOLOGY TRAIL  
HIVEL, KY 41642  
PHONE: (606) 874-7550  
FAX: (606) 874-7551  
EMAIL: INFO@EKN.COM  
WEBSITE: WWW.EKN.COM



VIA: U.S. CERTIFIED MAIL

PUBLIC NOTICE

November 10, 2009

Dexter & Alma Little  
233 Clear Fork Road  
Hazard, KY 41701

RE: Public Notice-Public Service Commission of Kentucky (Case No. 2009-00424)

East Kentucky Network, LLC d/b/a Appalachian Wireless has applied to the Public Service Commission of Kentucky for a Certificate of Public Convenience and Necessity to construct and operate a new facility to provide cellular telecommunications service in Knott County. The facility will include a 180 foot self-supporting tower with attached antennas extending upwards, and an equipment shelter located on a tract of land approximately .50 miles north of Cordia in Knott County, Kentucky. A map showing the location of the proposed new facility is enclosed. This notice is being sent to you because you may own property or reside within a 500' radius of the proposed tower or within a 200' radius of the proposed or existing access road.

The Commission invites your comments regarding the proposed construction. You also have the right to intervene in this matter. The Commission must receive your initial communication within 20 days of the date of this letter as shown above.

Your comments and request for intervention should be addressed to: Executive Director's Office, Public Service Commission of Kentucky, P.O. Box 615, Frankfort, KY 40602. Please refer to Case No. 2009-00424 in your correspondence.

Sincerely,

A handwritten signature in cursive script that reads "Lynn Haney".

Lynn Haney  
Staff Accountant

Enclosure 1

EAST KENTUCKY NETWORK  
101 TECHNOLOGY TRAIL  
IVEL, KY 41642  
PHONE: (606) 874-7550  
FAX: (606) 874-7551  
EMAIL: INFO@EKN.COM  
WEBSITE: WWW.EKN.COM



VIA: U.S. CERTIFIED MAIL

PUBLIC NOTICE

November 10, 2009

William Feltner  
309 Clear Fork Road  
Hazard, KY 41701

RE: Public Notice-Public Service Commission of Kentucky (Case No. 2009-00424)

East Kentucky Network, LLC d/b/a Appalachian Wireless has applied to the Public Service Commission of Kentucky for a Certificate of Public Convenience and Necessity to construct and operate a new facility to provide cellular telecommunications service in Knott County. The facility will include a 180 foot self-supporting tower with attached antennas extending upwards, and an equipment shelter located on a tract of land approximately .50 miles north of Cordia in Knott County, Kentucky. A map showing the location of the proposed new facility is enclosed. This notice is being sent to you because you may own property or reside within a 500' radius of the proposed tower or within a 200' radius of the proposed or existing access road.

The Commission invites your comments regarding the proposed construction. You also have the right to intervene in this matter. The Commission must receive your initial communication within 20 days of the date of this letter as shown above.

Your comments and request for intervention should be addressed to: Executive Director's Office, Public Service Commission of Kentucky, P.O. Box 615, Frankfort, KY 40602. Please refer to Case No. 2009-00424 in your correspondence.

Sincerely,

A handwritten signature in cursive script that reads "Lynn Haney". The signature is written in black ink and is positioned above the printed name and title.

Lynn Haney  
Staff Accountant

Enclosure 1



Topo USA® 5.0

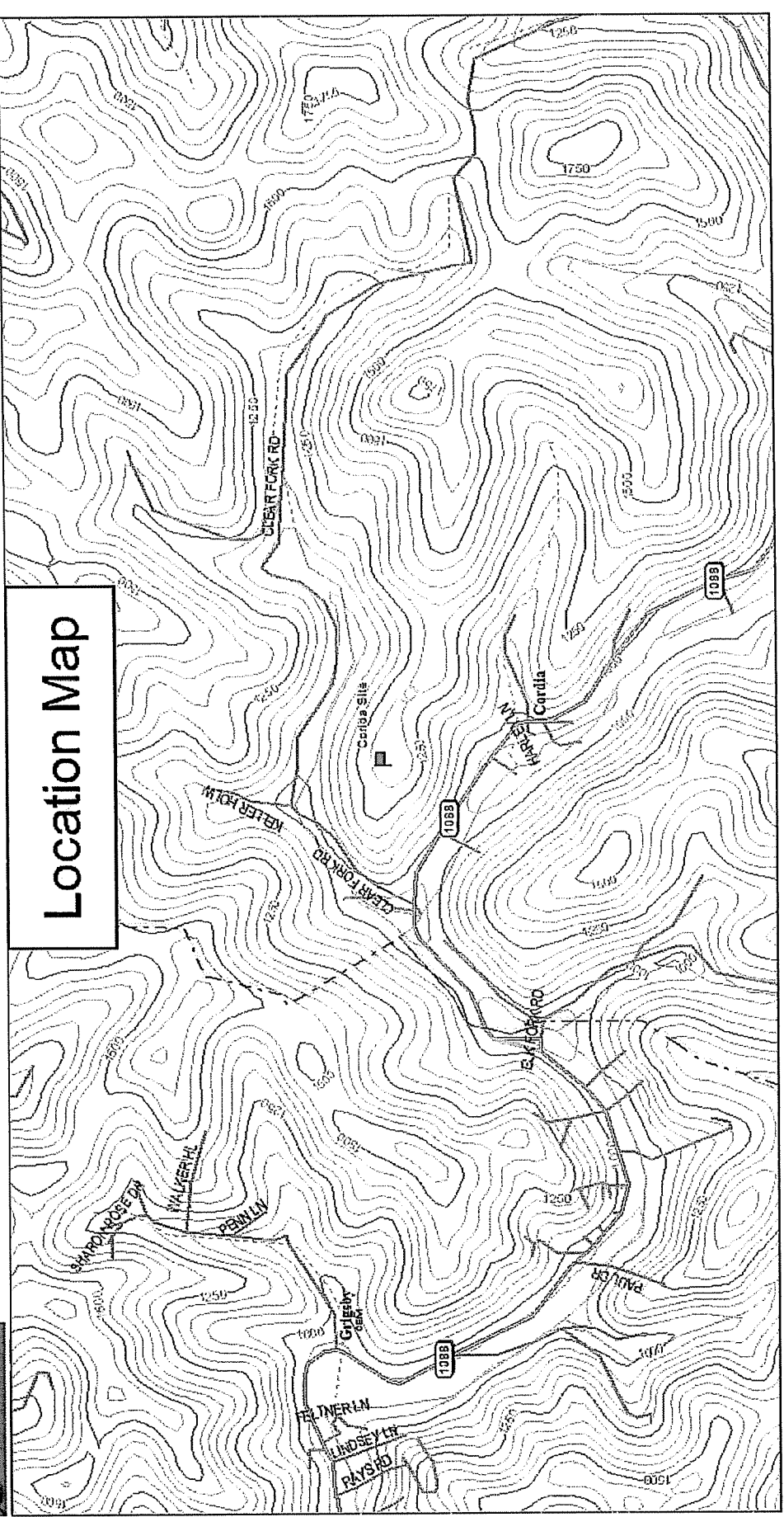

# Location Map

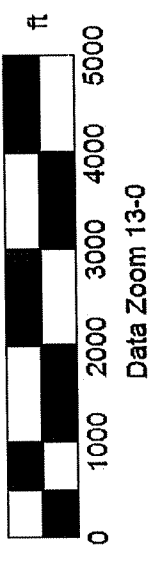

Data use subject to license.  
 © 2004 DeLorme. Topo USA® 5.0.  
[www.delorme.com](http://www.delorme.com)

Data Zoom 13-0





EAST KENTUCKY NETWORK  
101 TECHNOLOGY TRAIL  
IVEL, KY 41642  
PHONE: (606) 874-7550  
FAX: (606) 874-7551  
EMAIL: INFO@EKN.COM  
WEBSITE: WWW.EKN.COM



VIA: U.S. CERTIFIED MAIL

November 10, 2009

Randy Thompson, Judge Executive  
P.O. Box 505  
Hindman, KY 41822

RE: Public Notice-Public Service Commission of Kentucky (Case No. 2009-00424)

East Kentucky Network, LLC d/b/a Appalachian Wireless has applied to the Public Service Commission of Kentucky for a Certificate of Public Convenience and Necessity to construct and operate a new facility to provide cellular telecommunications service in Knott County. The facility will include a 180 foot self-supporting tower with attached antennas extending upwards, and an equipment shelter located on a tract of land approximately .50 miles north of Cordia in Knott County, Kentucky. A map showing the location of the proposed new facility is enclosed. This notice is being sent to you because you are the County Judge Executive of Knott County.

The Commission invites your comments regarding the proposed construction. You also have the right to intervene in this matter. The Commission must receive your initial communication within 20 days of the date of this letter as shown above.

Your comments and request for intervention should be addressed to: Executive Director's Office, Public Service Commission of Kentucky, P.O. Box 615, Frankfort, KY 40602. Please refer to Case No. 2009-00424 in your correspondence.

Sincerely,

A handwritten signature in cursive script that reads "Lynn Haney".

Lynn Haney  
Staff Accountant

Enclosure

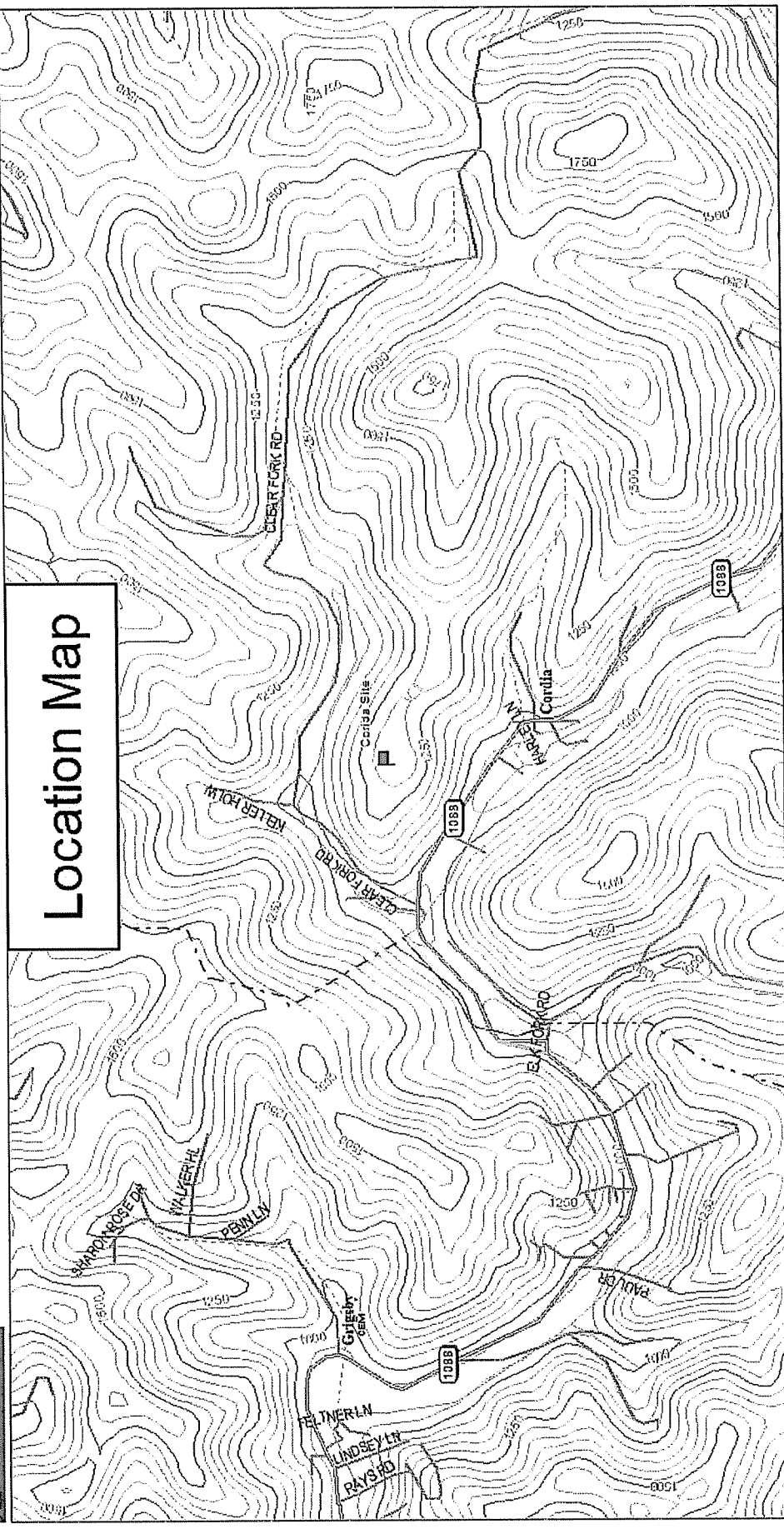

Location Map

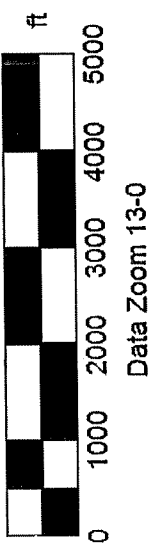
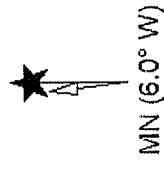

Data use subject to license.  
© 2004 DeLorme. Topo USA® 5.0.  
www.delorme.com

dba Appalachian Wireless  
101 Technology Trail  
Ivel, KY 41642  
Phone: 606-874-7550  
Fax: 606-791-2225



**To:** The Troublesome Creek Times  
Attn: Sharon Hall

**From:** Lynn Haney  
Staff Accountant – Fixed Assets

---

**Fax:**

**Date:** November 9, 2009

---

**Re:** PUBLIC NOTICE ADVERTISEMENT

**Pages:** 1

**Please place the following Public Notice Advertisement in the Troublesome Creek Times for the next two weeks.**

PUBLIC NOTICE:  
RE: Public Service Commission of Kentucky (CASE NO. 2009-00424)  
Public Notice is hereby given that East Kentucky Network, LLC, dba Appalachian Wireless has applied to the Kentucky Public Service Commission to construct a cellular telecommunications tower on a tract of land located approximately 0.5 miles North of Cordia in Knott County, Kentucky. The proposed tower will be a 180 foot self-supporting tower with attached antennas. If you would like to respond to this notice, please contact the Executive Director, Public Service Commission, 211 Sower Boulevard, PO Box 615, Frankfort, Kentucky 40602. Please refer to Case No. 2009-00424.

If you have any questions about the placement of the above mentioned notice, please call me at 606-791-2375, ext. 1007.

Thank you,

Lynn Haney  
Staff Accountant – Fixed Assets

The message above and the information contained in the documents transmitted are confidential and intended only for the person(s) named above. Dissemination, distribution or copying of this communication by anyone other than the person(s) named above is prohibited. If you have received this communication in error, please notify us immediately by telephone and return the original message to us at the address listed above via regular mail. Thank you.

**Lynn Haney**

---

**From:** shall@troublesomecreektimes.com  
**Sent:** Tuesday, November 10, 2009 9:02 PM  
**To:** Lynn Haney  
**Subject:** Re: FW: East Kentucky Network Public Service Announcement

yes, it will run Nov. 12 and 16th.  
Thanks,  
Sharon

On Tue, 10 Nov 2009 10:51:09 -0500, "Lynn Haney" <lhaney@ekn.com> wrote:

> Sharon,  
>  
>  
>  
> I did not receive confirmation on this email. Can you please confirm  
that  
> this notice will be in the Nov 12 & 19th editions?  
>  
>

> Thanks,  
>  
>

> Lynn Haney  
>  
> Staff Accountant-Fixed Assets  
>  
> East Kentucky Network, LLC

> dba Appalachian Wireless  
>  
>

> (606) 791-2375 ext. 1007  
>

> (606) 791-2225 (fax)  
>  
>

> \_\_\_\_\_  
> From: Lynn Haney [mailto:lhaney@ekn.com]  
> Sent: Monday, November 09, 2009 4:26 PM  
> To: 'shall@troublesomecreektimes.com'  
> Subject: East Kentucky Network Public Service Announcement  
> Importance: High  
>  
>

> Sharon,  
>  
>

> I have attached the public notice advertisement to be placed in the  
> Troublesome Creek Times for the next 2 weeks. It is my understanding  
that  
> it will run in the November 12 & November 19 editions.  
>  
>

> If you have any questions, feel free to contact me.  
>  
>

>  
> Thank you for your assistance.  
>  
>  
> Lynn Haney  
>  
> Staff Accountant-Fixed Assets  
>  
> East Kentucky Network, LLC  
>  
> dba Appalachian Wireless  
>  
>  
>  
> (606) 791-2375 ext. 1007  
>  
> (606) 791-2225 (fax)



**WENDELL R. HOLMES, P.G.**

PO Box 82  
Myra, KY 41549  
(606) 438-7250

November 16, 2009

**Cordia Tower Site**

**Purpose:**

A site assessment was conducted for Appalachian Wireless on a tract of land located in Knott County near Cordia, Kentucky. The site of the proposed tower is now forestland. The purpose of this investigation was to determine the depth to bedrock and of what type of rock the bedrock consists.

**Site Investigation:**

The outcrop method was used to determine the type of bedrock material at the proposed tower site. It is approximately 0.25 feet to the sandy shale bedrock. (See attached page for descriptions of materials encountered.) The terrain in Knott County is moderately to very steep. The tower site is located on a ridgeline between Clear Fork and Lotts Creek, both being tributaries of the North Fork of the Kentucky River, approximately five tenths of a mile northwest of Cordia in Knott County. The sandy shale formation below the tower site is approximately 10.00 feet thick, based on the information obtained from the site investigation and geological maps of the area.

**Conclusions:**

The proposed tower site is located on a ridge in the area. The sandy shale bedrock on the proposed tower site is part of the Breathitt Formation, and is middle to lower Pennsylvanian in age. Tests were not conducted to determine the load-bearing strength of the bedrock. However, it is apparent that the tower will be constructed on the sandy shale bedrock formation.

The field work for this site was performed by Wendell R. Holmes, using generally accepted methods in the practice of geological science.



WENDELL R. HOLMES, P.G.

P.O. Box 82  
Myra, Ky. 41549  
(606)438-7250

Geologist Log

Location: Cordia Tower Site

Unit Thickness	Total depth	Strata	Description
0.25'	0.25'	Soil	Yellow and Brown, with shale Fragments
10.00'	10.25'36.50'	Sandy shale	Brown, gray and Weathered







P.O. BOX 25  
 HENDERSON, KY 42419  
 PHONE: (270) 830-8512  
 FAX: (270) 830-8475

SCALE: N.T.S.	PROPRIETARY STATEMENT: THIS DRAWING IS THE PROPERTY OF ALLSTATE TOWER CO. IT IS NOT TO BE REPRODUCED OR COPIED IN ANYWAY WITHOUT PRIOR WRITTEN CONSENT OF ALLSTATE TOWER CO.	
TOLERANCE BANDS ALL DIMENSIONS ARE ±1/16" ALL ANGULAR DIM ARE ±1/2" UNLESS OTHERWISE NOTED	CUSTOMER: APPALACHIAN WIRELESS	DRAWN BY: W.MILLER
APPROX. WEIGHT 22.14 KIPS	DESCRIPTION: 180' SELF SUPPORT TOWER	DATE: 11/12/2009
	LOCATION: KNOT COUNTY, KY	REV: X
	SITE: CORDIA	REV. DATE: X
	PROPOSAL #: S.S.T. DESIGN DRAWING	JOB NO. 28089E
		SHEET A

LEG DIA.	Ø4"	Ø3.75"	Ø3.5"	Ø3.25"	Ø3.25"	Ø3"	Ø2.75"	Ø2.5"	Ø1.75"
DIAGONALS	L2.5" x .1875"	L2" x .1875"	N/A	N/A	N/A	N/A	A	A	A
GIRTS									
BRACE BOLTS	Ø.75"	Ø1.25"	Ø.625"				Ø.5"		
FLANGE BOLTS							Ø1"		
# OF BAYS	3 BAY : X-BRACED		4 BAY : X-BRACED						

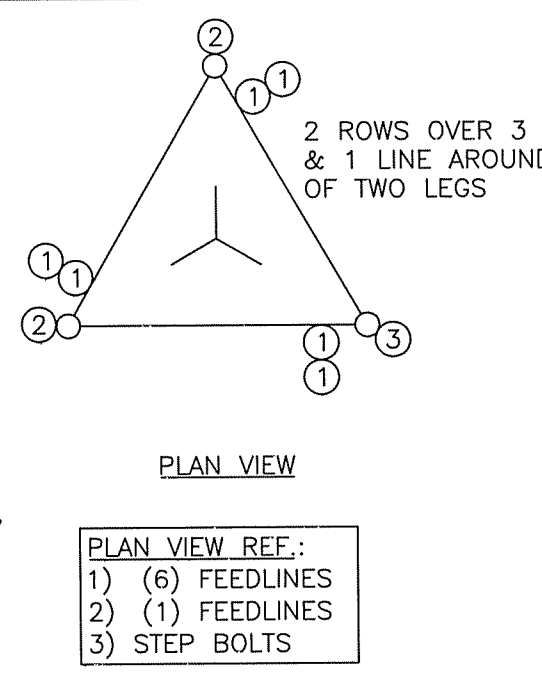
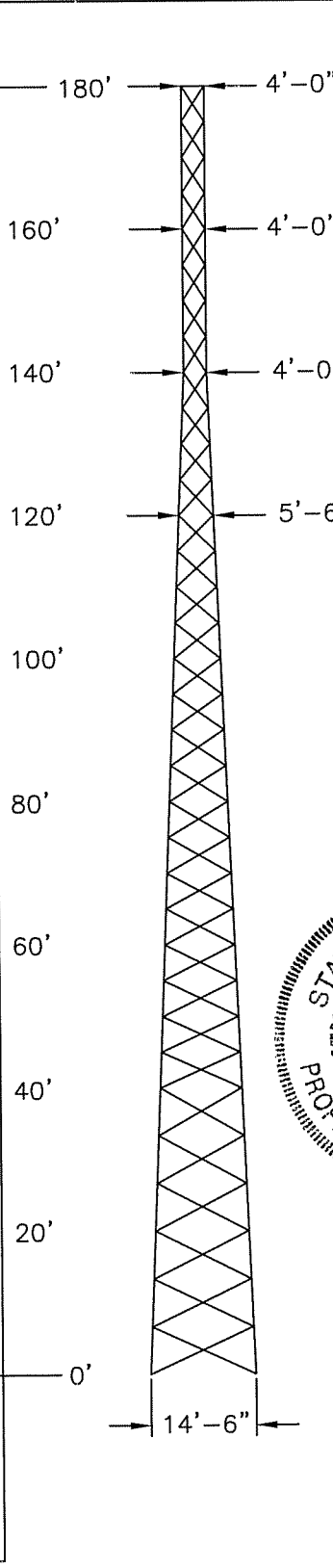

BASE REACTIONS:(FACTORED)	
TOTAL SHEAR	= 33 KIPS
AXIAL LOAD	= 41 KIPS
UPLIFT / LEG	= 279 KIPS
COMP. / LEG	= 306 KIPS
O.T. MOMENT	= 3668 FT-K
SYMBOL LIST:	
A)	L1.75" x .1875"

DESIGN NOTES:  
 1) ALL LEGS ARE SOLID ROUND ASTM A-572 GRADE : Fy ≥ 50 KSI.  
 2) ALL BRACE MATERIAL IS ASTM A-36 : Fy ≥ 36 KSI.  
 3) ALL BRACE AND FLANGE BOLTS ARE A325-X.  
 4) (8) Ø1.5" x 6'-0" LONG A-36 ANCHOR BOLTS PER LEG.  
 5) TOWER IS DESIGNED FOR A 90 MPH WIND SPEED IN AND A 30 M.P.H. WIND SPEED WITH 0.75" OF ICE IN ACCORDANCE WITH THE TIA/EIA-222-G.

ELEV.	ANTENNA	FEEDLINE
180'	(12) 4' X 1' CELLULAR PANELS	(12) 1.625"
170'	(12) 4' X 1' CELLULAR PANELS	(12) 1.625"
160'	(12) 4' X 1' CELLULAR PANELS	(12) 1.625"
150'	(1) 6' SOLID DISHES	(1) 1.625"
140'	(1) 6' SOLID DISHES	(1) 1.625"

-- STEP BOLTS UTILIZED FOR CLIMBING WITH SAFETY CLIMB DEVICE.  
 -- SEE PLAN VIEW FOR FEEDLINE DISTRIBUTION.

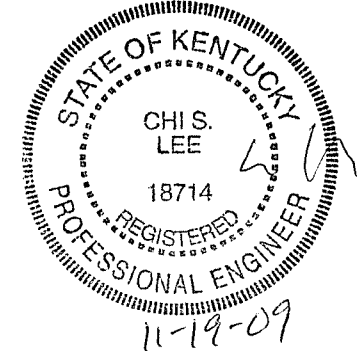



P.O. BOX 25  
 HENDERSON, KY 42419  
 PHONE: (270) 830-8512  
 FAX: (270) 830-8475

SCALE: N.T.S.	PROPRIETARY STATEMENT: THIS DRAWING IS THE PROPERTY OF ALLSTATE TOWER CO. IT IS NOT TO BE REPRODUCED OR COPIED IN ANYWAY WITHOUT PRIOR WRITTEN CONSENT OF ALLSTATE TOWER CO.	DRAWN BY: W.MILLER
TOLERANCE BANDS ALL DIMENSIONS ARE ±1/16" ALL ANGULAR DIM ARE ±1/2° UNLESS OTHERWISE NOTED	CUSTOMER: APPALACHIAN WIRELESS	DATE: 11/23/2009
APPROX. WEIGHT N/A	DESCRIPTION: PAD & PIER FOUNDATION DESIGN	REV: X
	LOCATION: KNOTT COUNTY, KY	REV DATE: X
	SITE: CORDIA	JOB NO 28089E
	FILE NAME: S.S.T. DESIGN DRAWING	SHEET B

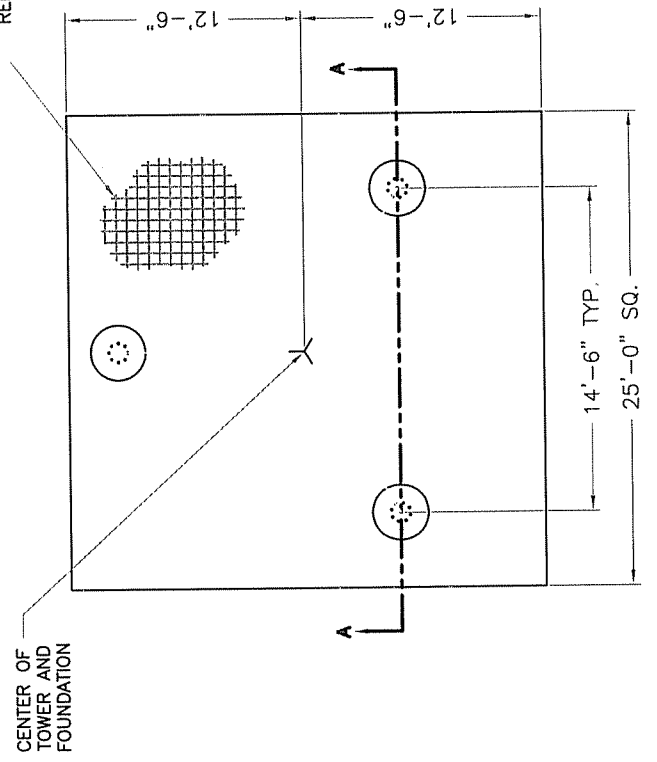

PLAN VIEW

TOTAL VOLUME OF CONCRETE = 38 YD<sup>3</sup>

FOUNDATION INSTALLATION/DESIGN NOTES:

- THIS FOUNDATION IS DESIGNED TO MEET ALL STANDARDS SET FORTH BY ACI 318: AMERICAN CONCRETE INSTITUTE; BUILDING CODE REQUIREMENTS FOR STRUCTURAL CONCRETE. ANSI/TIA/EIA 222-G; STRUCTURAL STANDARDS FOR STEEL ANTENNA TOWERS, AND ANTENNA SUPPORTING STRUCTURES.
- THIS FOUNDATION IS DESIGNED UTILIZING THE GEOTECHNICAL REPORT PERFORMED BY WENDELL R. HOLMES; DATED 11-16-09. THE FOUNDATION CONTRACTOR SHALL INSTALL THE FOUNDATIONS IN ACCORDANCE WITH THE RECOMMENDATIONS OF THE GEOTECHNICAL REPORT.
- ALL WORK PERFORMED FROM THESE DRAWINGS SHOULD BE BY QUALIFIED CONTRACTORS EXPERIENCED IN TOWER FOUNDATION CONSTRUCTION.
- ALL FOOTING EXCAVATIONS SHALL BE MANUALLY CLEANED PRIOR TO PLACING CONCRETE. COMPACT THE EXPOSED SOIL SURFACE AND ANY GRANULAR FILL UNDER THE FOUNDATION TO 95% OF THE MODIFIED PROCTOR DENSITY.
- ALL CONCRETE SHALL HAVE A MINIMUM COMPRESSIVE STRENGTH OF 3000 PSI AFTER 28 DAYS. COPIES OF THE CONCRETE CYLINDER TEST REPORTS SHALL BE SENT TO THE RESIDENT ENGINEER / INSPECTOR.
- MINIMUM CONCRETE COVER FOR REINFORCING BARS SHALL BE 3".
- FIELD BENDING OR WELDING OF REINFORCING BARS IS NOT PERMITTED.
- PROVIDE CHAMFERS AT ALL EXPOSED CORNERS OF CONCRETE.
- BACKFILL NEAR AND AROUND THE FOUNDATIONS SHALL BE A WELL GRADED FILL MATERIAL PLACED IN 8" THICK LAYERS THAT HAS BEEN COMPACTED TO 95% OF THE MODIFIED PROCTOR DENSITY PER ASTM D1557.
- SOME DETAIL HAS BEEN PURPOSELY OMITTED TO CLARIFY ILLUSTRATION.
- TOWER OWNER AGREES THAT THERE WILL BE NO PROBLEM IN REMOVING ROCK FOR THIS SITE.

REINFORCEMENT BAR MAT

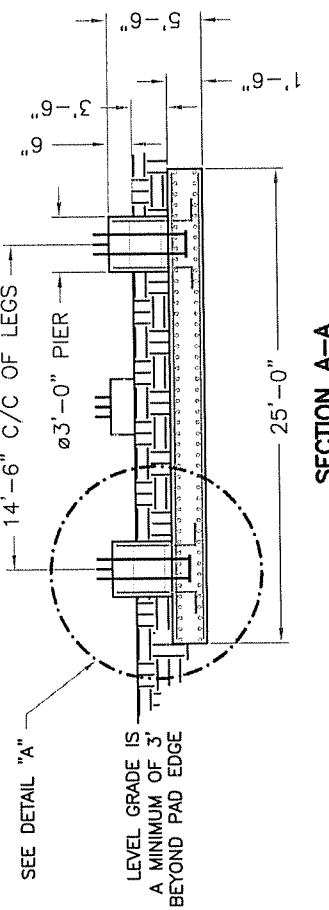

SECTION A-A

(8) ø1.5" X 6'-0" OVERALL LENGTH ANCHOR BOLTS W/ 3/4" THK BEARING PLATE AT THE BOTTOM OF THE ANCHOR BOLT CLUSTER (5' MIN. ANCHOR BOLT EMBEDMENT).

USE EPOXY BONDING AGENT WHEN POURED SEPARATELY

(8) #9 VERTICAL BARS w/ #4 TIES AT 14" ON CENTER

(32) #9 HORIZONTAL BARS X 24'-6" LONG EQUALLY SPACED EACH WAY AT TOP AND BOTTOM OF MAT. (TOTAL = 128)

DETAIL "A"

- REINFORCEMENT BAR SPlicing:
- ALL LAP SPICES SHALL CONFORM TO ACI 318 REQUIREMENTS.
  - REFER TO CHART BELOW WHEN REINFORCEMENT BAR SPlicing IS NECESSARY.

REINFORCING BAR SIZE	LAP SPlice LENGTH
3	15"
4	17"
5	21"
6	26"
7	30"
8	36"
9	45"
10	58"
11	71"

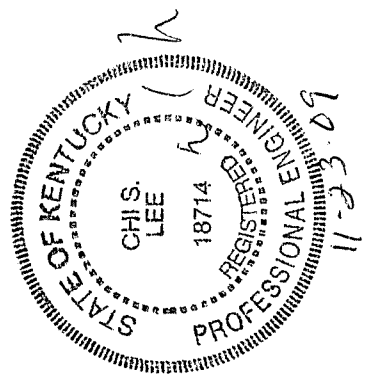





<< OE/AAA

**Notice of Proposed Construction or Alteration - Off Airport**

**Project Name:** EAST-000134896-09      **Sponsor:** East Kentucky Network, LLC

**Details for Case : Cordia**

Show Project Summary

**Case Status**

**ASN:** 2009-ASO-7141-OE      **Date Accepted:** 12/03/2009  
**Status:** Accepted      **Date Determined:**  
**Letters:** None  
**Documents:** 12/03/2009 Cordia\_Cover Ltr\_...

**Construction / Alteration Information**

**Notice Of:** Construction  
**Duration:** Permanent  
**if Temporary :** Months: Days:  
**Work Schedule - Start:** 01/01/2010  
**Work Schedule - End:** 01/10/2010  
**State Filing:** Filed with State

**Structure Summary**

**Structure Type:** Tower  
**Structure Name:** Cordia  
**FCC Number:**  
**Prior ASN:**

**Structure Details**

**Latitude:** 37° 17' 3.60" N  
**Longitude:** 83° 6' 46.10" W  
**Horizontal Datum:** NAD83  
**Site Elevation (SE):** 1438 (nearest foot)  
**Structure Height (AGL):** 190 (nearest foot)  
**Requested Marking/Lighting:** None  
**Recommended Marking/Lighting:** **Other :**  
**Current Marking/Lighting:** None  
**Other :**   
**Nearest City:** Cordia  
**Nearest State:** Kentucky  
**Description of Location:** Site will be located approx. 0.4 mi (0.6 km) NNW of Cordia (Knott), KY  
**Description of Proposal:** A new 180' tower plus top-mounted antennas (overall height of 190' AGL)

**Common Frequency Bands**

Low Freq	High Freq	Freq Unit	ERP	ERP Unit
806	824	MHz	500	W
824	849	MHz	500	W
851	866	MHz	500	W
869	894	MHz	500	W
896	901	MHz	500	W
901	902	MHz	7	W
930	931	MHz	3500	W
931	932	MHz	3500	W
932	932.5	MHz	17	dBW
935	940	MHz	1000	W
940	941	MHz	3500	W
1850	1910	MHz	1640	W
1930	1990	MHz	1640	W
2305	2310	MHz	2000	W
2345	2360	MHz	2000	W

**Specific Frequencies**



**EAST KENTUCKY NETWORK, LLC  
DBA APPALACHIAN WIRELESS**

**FINANCIAL REPORT**

**December 31, 2008**

## CONTENTS

	Page
INDEPENDENT AUDITOR'S REPORT ON THE FINANCIAL STATEMENTS	1
FINANCIAL STATEMENTS	
Balance sheets	2
Statements of income	3
Statements of members' equity	4
Statements of cash flows	5-6
Notes to financial statements	7-14
INDEPENDENT AUDITOR'S REPORT ON THE SUPPLEMENTARY INFORMATION	15
SUPPLEMENTARY INFORMATION	
Statement of income detail	16 and 17



## INDEPENDENT AUDITOR'S REPORT

To the Members  
East Kentucky Network, LLC  
dba Appalachian Wireless  
Ivel, Kentucky

We have audited the accompanying balance sheets of East Kentucky Network, LLC, dba Appalachian Wireless as of December 31, 2008 and 2007 and the related statements of income, members' equity and cash flows for the years then ended. These financial statements are the responsibility of the Company's management. Our responsibility is to express an opinion on these financial statements based on our audits.

We conducted our audits in accordance with auditing standards generally accepted in the United States of America. Those standards require that we plan and perform the audit to obtain reasonable assurance about whether the financial statements are free of material misstatement. An audit includes examining, on a test basis, evidence supporting the amounts and disclosures in the financial statements. An audit also includes assessing the accounting principles used and significant estimates made by management, as well as evaluating the overall financial statement presentation. We believe that our audits provide a reasonable basis for our opinion.

In our opinion, the financial statements referred to above present fairly, in all material respects, the financial position of East Kentucky Network, LLC, dba Appalachian Wireless as of December 31, 2008 and 2007 and the results of its operations and its cash flows for the years then ended in conformity with accounting principles generally accepted in the United States of America.

*Jones, Nale & Mattingly P.C.*

Louisville, Kentucky  
March 6, 2009

**EAST KENTUCKY NETWORK, LLC  
DBA APPALACHIAN WIRELESS**

**BALANCE SHEETS  
December 31, 2008 and 2007**

ASSETS	<u>2008</u>	<u>2007</u>
<b>CURRENT ASSETS</b>		
Cash and cash equivalents	\$ 5,078,319	\$ 1,751,689
Short-term investments	166,846	127,015
Accounts receivable, less allowance for doubtful accounts of \$1,054,283 in 2008 and \$803,092 in 2007	4,359,740	3,541,622
Accounts receivable, members (Notes 5 and 6)	88,078	79,803
Inventory	3,053,445	2,979,257
Prepaid expenses	411,948	431,859
Total current assets	<u>\$ 13,158,376</u>	<u>\$ 8,911,245</u>
 <b>PROPERTY, PLANT AND EQUIPMENT (Note 3)</b>		
Plant in service:		
General support	\$ 25,370,575	\$ 22,417,029
MTSO equipment	20,505,774	15,068,558
Cell equipment	55,340,782	45,543,309
Paging equipment	3,321,068	3,321,068
Fiber ring	7,429,057	6,606,546
Unfinished plant	1,960,503	1,825,466
	<u>\$113,927,759</u>	<u>\$ 94,781,976</u>
Less accumulated depreciation	48,072,427	40,355,585
	<u>\$ 65,855,332</u>	<u>\$ 54,426,391</u>
 <b>OTHER ASSETS</b>		
Investment in affiliated company, RTFC	\$ 112,712	\$ 112,653
Intangible assets, net of accumulated amortization of \$3,697,725 in 2008 and \$3,122,139 in 2007 (Note 2)	5,255,760	4,242,306
Other	25,403	26,431
	<u>\$ 5,393,875</u>	<u>\$ 4,381,390</u>
	<u>\$ 84,407,583</u>	<u>\$ 67,719,026</u>

The Notes to Financial Statements are an integral part of these statements.

LIABILITIES AND MEMBERS' EQUITY	<u>2008</u>	<u>2007</u>
<b>CURRENT LIABILITIES</b>		
Current maturities of long-term debt (Note 3)	\$ 3,852,381	\$ 1,400,000
Accounts payable	1,772,238	938,193
Capital distributions payable	--	615,383
Accounts payable, member (Notes 5 and 6)	49,579	45,267
Accrued expenses	1,208,138	1,123,649
Customer deposits	600,872	453,470
Total current liabilities	<u>\$ 7,483,208</u>	<u>\$ 4,575,962</u>
LONG-TERM DEBT, less current maturities (Note 3)	<u>\$ 16,388,735</u>	<u>\$ 12,350,000</u>
INTEREST RATE SWAPS (Note 8)	<u>\$ 2,067,821</u>	<u>\$ 572,632</u>
<b>MEMBERS' EQUITY</b>		
Members' capital accounts	\$ 60,535,640	\$ 50,793,064
Accumulated other comprehensive (loss)	(2,067,821)	(572,632)
	<u>\$ 58,467,819</u>	<u>\$ 50,220,432</u>
	<u><u>\$ 84,407,583</u></u>	<u><u>\$ 67,719,026</u></u>

**EAST KENTUCKY NETWORK, LLC  
DBA APPALACHIAN WIRELESS**

**STATEMENTS OF INCOME  
Years Ended December 31, 2008 and 2007**

	<u>2008</u>	<u>2007</u>
<b>REVENUE</b>		
Retail	\$ 35,590,860	\$ 29,480,700
Roamer	12,592,115	9,239,822
Long distance	214,296	196,787
Paging	566,677	684,064
Equipment sales, cellular	2,248,939	3,006,173
Equipment sales, paging	35,777	33,862
Other	7,916,897	4,513,769
Total revenue	<u>\$ 59,165,561</u>	<u>\$ 47,155,177</u>
<b>EXPENSES</b>		
Cost of cellular service	\$ 12,861,903	\$ 9,010,171
Cost of paging service	332,386	309,524
Cost of equipment sales, cellular	11,656,367	9,978,249
Cost of equipment sales, paging	56,705	59,307
Customer service	1,313,033	1,424,197
Billing	1,383,121	1,086,540
Selling	3,731,205	2,760,702
Maintenance	1,838,940	1,597,342
Utilities	711,446	562,455
Bad debts	802,158	1,165,669
Cell site rental	237,540	175,720
Taxes and licenses	965,327	873,366
Advertising	2,968,190	1,774,317
General and administrative	3,106,380	2,635,470
Occupancy	403,800	353,641
Depreciation	7,703,016	6,987,459
Amortization	670,464	528,232
Total expenses	<u>\$ 50,741,981</u>	<u>\$ 41,282,361</u>
Income from operations	<u>\$ 8,423,580</u>	<u>\$ 5,872,816</u>
<b>OTHER INCOME (EXPENSE)</b>		
Interest income	\$ 56,023	\$ 42,847
Interest expense	(1,242,505)	(885,156)
Universal Service Fund income (Note 7)	6,680,698	4,910,497
	<u>\$ 5,494,216</u>	<u>\$ 4,068,188</u>
Net income	<u>\$ 13,917,796</u>	<u>\$ 9,941,004</u>

The Notes to Financial Statements are an integral part of these statements.

**EAST KENTUCKY NETWORK, LLC  
DBA APPALACHIAN WIRELESS**

**STATEMENTS OF MEMBERS' EQUITY  
Years Ended December 31, 2008 and 2007**

	Cellular Services, Inc.	Gearhart Communi- cations Company, Inc.	Mountain Tele- communi- cations, Inc.	Thacker- Grigsby Telephone Co., Inc.	Peoples Rural Telephone Coop- erative Corp- oration, Inc.	Total
Balance, January 1, 2007	\$ 8,667,881	\$ 8,667,881	\$ 8,667,881	\$ 8,667,880	\$ 8,667,880	\$43,339,403
Comprehensive income:						
Net income	1,988,201	1,988,201	1,988,200	1,988,201	1,988,201	9,941,004
Change in fair value of interest rate swaps	(78,861)	(78,861)	(78,862)	(78,861)	(78,861)	(394,306)
Total comprehensive income	\$ 1,909,340	\$ 1,909,340	\$ 1,909,338	\$ 1,909,340	\$ 1,909,340	\$ 9,546,698
Capital distributions	(533,134)	(533,134)	(533,133)	(533,134)	(533,134)	(2,665,669)
Balance, December 31, 2007	<u>\$10,044,087</u>	<u>\$10,044,087</u>	<u>\$10,044,086</u>	<u>\$10,044,086</u>	<u>\$10,044,086</u>	<u>\$50,220,432</u>
Comprehensive income:						
Net income	2,783,559	2,783,559	2,783,559	2,783,560	2,783,559	13,917,796
Change in fair value of interest rate swaps	(299,038)	(299,038)	(299,038)	(299,038)	(299,037)	(1,495,189)
Total comprehensive income	\$ 2,484,521	\$ 2,484,521	\$ 2,484,521	\$ 2,484,522	\$ 2,484,522	\$12,422,607
Capital distributions	(835,044)	(835,044)	(835,044)	(835,044)	(835,044)	(4,175,220)
Balance, December 31, 2008	<u><u>\$11,693,564</u></u>	<u><u>\$11,693,564</u></u>	<u><u>\$11,693,563</u></u>	<u><u>\$11,693,564</u></u>	<u><u>\$11,693,564</u></u>	<u><u>\$58,467,819</u></u>

The Notes to Financial Statements are an integral part of these statements.

**EAST KENTUCKY NETWORK, LLC  
DBA APPALACHIAN WIRELESS**

**STATEMENTS OF CASH FLOWS  
Years Ended December 31, 2008 and 2007**

	<u>2008</u>	<u>2007</u>
<b>CASH FLOWS FROM OPERATING ACTIVITIES</b>		
Net income	\$ 13,917,796	\$ 9,941,004
Adjustments to reconcile net income to net cash provided by operating activities:		
Depreciation	7,703,016	6,987,459
Amortization	670,464	528,232
Changes in assets and liabilities, net of the effects of investing and financing activities:		
(Increase) in accounts receivable	(818,118)	(738,949)
(Increase) in accounts receivable, members	(8,275)	(42,191)
(Increase) in inventory	(74,188)	(1,395,218)
(Increase) decrease in prepaid expenses	19,911	(358,202)
Decrease in other assets	969	750,860
Increase (decrease) in accounts payable	834,045	(183,899)
Increase (decrease) in accounts payable, member	4,312	(2,449)
Increase (decrease) in accrued expenses	84,489	(1,222,038)
Increase in customer deposits	147,402	135,867
Net cash provided by operating activities	<u>\$ 22,481,823</u>	<u>\$ 14,400,476</u>
<b>CASH FLOWS FROM INVESTING ACTIVITIES</b>		
Purchase of property, plant and equipment	\$ (19,165,600)	\$ (12,765,603)
Purchase of intangible assets	(1,650,275)	(120,500)
Proceeds from sale of short-term investments	(39,831)	(80,744)
Net cash (used in) investing activities	<u>\$ (20,855,706)</u>	<u>\$ (12,966,847)</u>
<b>CASH FLOWS FROM FINANCING ACTIVITIES</b>		
Capital distributions	\$ (4,790,603)	\$ (2,050,286)
Proceeds from long-term borrowings	8,250,000	1,000,000
Payments on long-term borrowings	(1,758,884)	(1,450,000)
Net cash provided by (used in) financing activities	<u>\$ 1,700,513</u>	<u>\$ (2,500,286)</u>
 Net increase (decrease) in cash and cash equivalents	 \$ 3,326,630	 \$ (1,066,657)
 Cash and cash equivalents:		
Beginning	<u>1,751,689</u>	<u>2,818,346</u>
Ending	<u>\$ 5,078,319</u>	<u>\$ 1,751,689</u>

The Notes to Financial Statements are an integral part of these statements.

**EAST KENTUCKY NETWORK, LLC  
DBA APPALACHIAN WIRELESS**

**STATEMENTS OF CASH FLOWS (Continued)  
Years Ended December 31, 2008 and 2007**

	<u>2008</u>	<u>2007</u>
SUPPLEMENTAL DISCLOSURE OF CASH FLOW INFORMATION		
Cash payments for interest	<u>\$ 1,178,953</u>	<u>\$ 885,156</u>
 SUPPLEMENTAL SCHEDULE OF NONCASH INVESTING AND FINANCING ACTIVITIES		
Capital distributions declared	<u>\$ --</u>	<u>\$ 615,383</u>

The Notes to Financial Statements are an integral part of these statements.

**EAST KENTUCKY NETWORK, LLC  
DBA APPALACHIAN WIRELESS**

**NOTES TO FINANCIAL STATEMENTS**

Note 1. Summary of Significant Accounting Policies

Nature of operations

East Kentucky Network, LLC, dba Appalachian Wireless, is a Kentucky limited liability company formed by the merger of Appalachian Cellular, LLC, Mountaineer Cellular, LLC and East Kentucky Network, LLC on January 1, 2000. The Company is engaged in cellular telephone communications and paging services to residential and commercial customers located in eastern Kentucky. The Company's five members consist of Cellular Services, Inc.; Gearheart Communications Company, Inc.; Mountain Telecommunications, Inc.; Peoples Rural Telephone Cooperative Corporation, Inc.; and Thacker-Grigsby Telephone Co., Inc.

Cash

The Company maintains its cash balances, which may exceed the federally insured limit, with several financial institutions. These financial institutions have strong credit ratings and management believes that credit risk related to the accounts is minimal.

Cash equivalents

For purposes of the statement of cash flows, the Company considers temporary investments having a maturity of three months or less to be cash equivalents.

Short-term investments

Certificates of deposit having original maturities between three and nine months are classified as short-term investments, are carried at cost, which approximates fair value, and are held to maturity. Fair value is determined by quoted prices for similar certificates of deposit in active markets.

Inventory

Inventory is composed of cellular telephone equipment, paging equipment, and accessories purchased for resale during the ordinary course of business. The inventory is valued at the lower of cost or market, cost being determined by the first-in, first-out (FIFO) method.

Property, plant and equipment

Property, plant and equipment are recorded at cost. Depreciation is provided using the straight-line method over the estimated useful lives of the assets.

Investment

The investment in affiliated company is composed of equity certificates in Rural Telephone Finance Cooperative and is reported at cost, which approximates fair value.



## NOTES TO FINANCIAL STATEMENTS

### Note 1. Summary of Significant Accounting Policies (Continued)

#### Intangible assets

The customer lists, non-compete agreements, FCC licenses, bond issuance costs, loan fees and use of name are recorded at cost and are being amortized over the life of the asset by the straight-line method.

#### Recognition of revenue

Cellular service and paging revenues are recognized when earned. Monthly access and feature charges are billed one month in advance and recognized as revenue the following month. Revenue from telephone and accessories sold are recognized as revenue upon delivery to the customer.

#### Advertising

Advertising costs are expensed as incurred. At December 31, 2008 and 2007, these costs were \$2,968,190 and \$1,774,317, respectively.

#### Income taxes

Under existing provisions of the Internal Revenue Code, the income or loss of a limited liability company is recognized by the members for income tax purposes. Accordingly, no provision for federal income taxes has been provided for in the accompanying financial statements.

The Company adopted the provisions of FASB Interpretation No. 48, *Accounting for Uncertainty in Income Taxes*, on January 1, 2008. The Company had no prior unrecognized tax benefits as a result of the implementation of Interpretation 48. There are no tax positions for which the ultimate deductibility is highly uncertain included in the balance sheet at December 31, 2008.

The Company recognizes interest accrued related to unrecognized tax benefits in interest expense and penalties in operating expenses. During the years ended December 31, 2008 and 2007 the Company did not recognize any interest or penalties.

#### Use of estimates

Management uses estimates and assumptions in preparing financial statements. Those estimates and assumptions affect the reported amounts of assets and liabilities, the disclosure of contingent assets and liabilities, and the reported revenues and expenses.

#### Comprehensive income

Comprehensive income consists of net income and other comprehensive income. Other comprehensive income includes the change in fair value of interest rate swaps which is also recognized as a separate component of equity.

**NOTES TO FINANCIAL STATEMENTS**

Note 1. Summary of Significant Accounting Policies (Continued)

Reclassification

Certain amounts presented in the prior period have been restated to conform with the current year presentation.

Note 2. Intangible Assets

Intangible assets consist of the following at December 31, 2008:

	<u>Gross Amount</u>	<u>Accumulated Amortization</u>
Customer lists	\$ 5,363,530	\$ (2,868,565)
Non-compete agreements	220,348	(150,977)
FCC licenses	2,452,368	(544,730)
Use of name	10,000	(5,669)
Other	907,239	(127,784)
	<u>\$ 8,953,485</u>	<u>\$ (3,697,725)</u>

Intangible assets consist of the following at December 31, 2007:

	<u>Gross Amount</u>	<u>Accumulated Amortization</u>
Customer lists	\$ 5,363,530	\$ (2,510,268)
Non-compete agreements	220,348	(136,257)
FCC licenses	1,262,093	(399,017)
Use of name	10,000	(5,001)
Other	508,474	(71,596)
	<u>\$ 7,364,445</u>	<u>\$ (3,122,139)</u>

**NOTES TO FINANCIAL STATEMENTS**

Note 2. Intangible Assets (Continued)

Aggregate amortization expense related to these intangible assets for the years ended December 31, 2008 and 2007 totaled \$575,586 and \$475,226, respectively. The following represents the total estimated amortization of intangible assets for each of the succeeding five years:

Year ending December 31:

2009	\$ 625,000
2010	625,000
2011	625,000
2012	625,000
2013	625,000

Note 3. Long-Term Debt

Long-term debt consists of the following at December 31:

	2008	2007
Note payable, Fifth Third Bank (a)	\$ 11,600,000	\$ 13,000,000
Line of credit, Fifth Third Bank (b)	-	750,000
Note payable, Fifth Third Bank (c)	8,641,116	-
	\$ 20,241,116	\$ 13,750,000

(a) On February 28, 2006, the Company issued \$14,200,000 in adjustable rate notes to restructure its debt. The notes were issued pursuant to a trust indenture between the Company and U.S. Bank National Association. Principal and interest on the notes are paid from funds drawn by the Trustee under an irrevocable letter of credit issued by Fifth Third Bank. The Notes are collateralized by the assets of the Company and mature on February 1, 2016. The Notes bear interest at a floating interest rate as determined by U.S. Bank National Association (4.60% at 12/31/08). However, the Company entered into an interest rate swap contract (original notional amount of \$14,200,000) that effectively converts its floating-rate debt into a fixed-rate of 5.32% (see Note 8). The note is payable in 10 annual installments of \$1,200,000 for 2007, \$1,400,000 for 2008 through 2012, and \$1,500,000 for 2013 through 2016, with a variable interest rate.

On February 2, 2009, the Company refinanced the remaining \$10,200,000 of the note with a new note payable that matures November 1, 2013, and renegotiated the terms of the interest rate swap contract.

(b) The line of credit agreement with Fifth Third Bank provides for borrowing up to \$2,000,000. The agreement carries a variable interest rate (4.90% at 12/31/08), is secured by the assets of the Company, and is due September 1, 2010.

## NOTES TO FINANCIAL STATEMENTS

### Note 3. Long-Term Debt (Continued)

(c) On September 1, 2008, the Company borrowed \$9,000,000 to restructure existing debt, purchase new equipment and upgrade existing equipment. The note is collateralized by the assets of the Company. Interest on the note is floating at monthly LIBOR plus 3.00% as determined by Fifth Third Securities, Inc (4.90% at 12/31/08). The Company also entered into an interest rate swap contract (original notional amount of \$9,000,000) that effectively converts its floating-rate debt into a fixed rate of 7.20% (see Note 8). The note is payable in monthly installments of \$107,143 plus interest with a balloon payment due on September 1, 2013.

Under terms of the Notes, the Company has also agreed, among other things, to maintain minimum debt service coverage and minimum debt to tangible worth ratios.

Approximate maturities or payments required on principal under note payable agreements for each of the succeeding five years are as follows:

Year ending December 31:

2009	\$ 3,852,381
2010	2,685,714
2011	2,685,714
2012	2,769,048
2013	8,248,258

### Note 4. Retirement Plans

The Company has a 401(k) plan for qualifying employees who have reached twenty-one years of age. Eligible employees are allowed to invest up to 15% of their compensation and the Company has agreed to match 100% of the first 3% of the employees' contribution and 50% of the employees' contribution between 3% and 5%. The Company contributed \$112,235 and \$81,606 matching funds for its 401(k) plan during the years ended December 31, 2008 and 2007, respectively.

The Company also offers an employer sponsored retirement savings plan for qualified employees who have reached twenty-one years of age. The Company has agreed to contribute 9% of the eligible employee's compensation, plus an additional 5% of the original contribution.

The Company contributed \$371,105 and \$355,059 to its retirement savings plan during the years ended December 31, 2008 and 2007, respectively.

### Note 5. Related Party Transactions

The Company shares personnel with four of its members. The Company paid \$157,825 and \$137,799 for shared personnel during the years ended December 31, 2008 and 2007, respectively. The Company also leased offices and warehouse space from three members. The leases are for an unspecified length of time. The annual lease expense related to these leases was \$20,301 and \$18,642 during the years ended December 31, 2008 and 2007, respectively.

**NOTES TO FINANCIAL STATEMENTS**

Note 5. Related Party Transactions (Continued)

The Company incurred interconnection, telephone, cable and internet access charges from its members aggregating \$1,047,239 and \$892,626 for the years ended December 31, 2008 and 2007, respectively.

The Company leases two cellular tower sites from the officers and majority shareholders of a member. The annual lease expense related to these leases was \$2,400 for the years ended December 31, 2008 and 2007. The leases are for an unspecified length of time. The Company also pays part of an annual lease for sharing a tower with a member for an annual fee of \$450. In addition, the Company leases one other site from a company owned by a member for an annual fee of \$3,600. The Company leases cellular tower sites from the parent company of one of its other members. The annual lease expense related to these leases was \$12,463 for the years ended December 31, 2008 and 2007. The leases are for five years with options to renew.

The Company pays commissions to two of its members for phone sales to customers. The amount of commissions paid to related parties during the years ended December 31, 2008 and 2007 was \$51,872 and \$43,644, respectively.

The Company pays fees to companies owned by its members for advertisement in telephone directories, television and on local billboards. The amount of advertising paid to related parties was \$98,276 and \$18,885 for the years ended December 31, 2008 and 2007, respectively.

Note 6. Operating Leases

The Company has entered into operating leases with its members and other customers to provide fiber optic transmission capacity and ancillary services. The terms of these leases are for 15 years. Total rental income earned from these operating lease commitments included in the statements of income was \$1,612,227 and \$1,267,544 for the years ended December 31, 2008 and 2007, respectively. Rental income earned from the Company's members from these leases was \$780,931 and \$607,789 for the years ended December 31, 2008 and 2007, respectively.

Investments in operating leases are as follows at December 31:

	2008	2007
Fiber ring	\$ 7,429,057	\$ 6,606,546
Accumulated depreciation	(2,143,096)	(1,687,693)
	\$ 5,285,961	\$ 4,918,853

The future minimum rental payments expected to be received under these lease agreements for each of the succeeding five years are approximately \$1,500,000 each year.

## NOTES TO FINANCIAL STATEMENTS

### Note 6. Operating Leases (Continued)

The Company has also entered into lease agreements to obtain fiber optic transmission and digital microwave transmission services; and to rent retail office facilities. The terms of these leases are between 5 and 15 years. Total rental expense incurred from these operating lease commitments included in the statements of income was \$805,277 and \$646,474 for the years ended December 31, 2008 and 2007, respectively. Rental expense incurred from the Company's members from these leases was \$291,461 and \$188,539 for the years ended December 31, 2008 and 2007, respectively. The future minimum lease payments required under these lease agreements for each of the succeeding five years are \$800,000 each year.

### Note 7. Eligible Telecommunication Carrier

During 2005, the Company was granted Eligible Telecommunication Carrier (ETC) status by the Kentucky Public Service Commission. As an ETC, the Company receives funding from the federal Universal Service Fund (USF) to support the high cost of providing local telephone service in rural areas. USF payments amounted to \$6,680,698 and \$4,910,497 for 2008 and 2007, respectively.

### Note 8. Derivative Financial Instruments, Interest Rate Swaps

The Company entered into two interest rate swap contracts with Fifth Third Bank for the purpose of converting floating-rate interest on its long-term debt to fixed rates. The interest rate swap effectively fixed \$14,200,000 at a rate of 5.32% until February 1, 2016 and fixed \$9,000,000 at a rate of 7.20% until September 1, 2013.

Under the swap contracts, the Company pays interest at 5.32% and 4.20% on the notional amounts and receives interest at LIBOR observed weekly (1.075% at December 31, 2008) and LIBOR observed monthly (1.90% at December 31, 2008), respectively. The interest rate swaps qualify as, and are designated as, cash flow hedges. The swaps are designed to hedge the risk of changes in interest payments on the notes caused by changes in LIBOR. The notional amounts do not represent actual amounts exchanged by the parties, but instead represent the amounts on which the contracts are based.

The swaps were issued at market terms so that they had no fair value or carrying value at their inception. The carrying amount of the swaps has been adjusted to their fair value at the end of the year, which because of changes in forecasted levels of LIBOR, resulted in reporting a liability for the fair value of the future net payments forecasted under the swaps. The swap contracts permit settlement prior to maturity only through termination by the Company. The settlement amounts are determined based on forecasted changes in interest rates required under fixed and variable legs of the swaps. The Company believes the settlement amounts are the best representation of the fair value of the swaps and has adjusted their carrying amounts to the settlement amounts at the end of the year.

## NOTES TO FINANCIAL STATEMENTS

### Note 8. Derivative Financial Instruments, Interest Rate Swaps (Continued)

The carrying amounts of the swaps are classified as noncurrent since management does not intend to terminate the swaps during 2009. Since the critical terms of the swaps and the notes are approximately the same, the swaps are assumed to be effective as hedges, and none of the changes in fair values are included in income. Accordingly, all of the adjustment of the swaps' carrying amount is reported as other comprehensive income or loss in the accompanying statements of members' equity. If the swaps are terminated early, the corresponding carrying amount would be reclassified into earnings. The Company does not hold or issue interest rate swaps or other financial instruments for trading purposes.

**INDEPENDENT AUDITOR'S REPORT ON  
THE SUPPLEMENTARY INFORMATION**

To the Members  
East Kentucky Network, LLC  
dba Appalachian Wireless  
Prestonsburg, Kentucky 41653

Our audit was made for the purpose of forming an opinion on the basic financial statements for the year ended December 31, 2008 and 2007, taken as a whole. The supplementary information shown on pages 16 and 17 is presented for purposes of additional analysis and is not a required part of the basic financial statements. The supplementary information for the year ended December 31, 2008 and 2007, has been subjected to the auditing procedures applied in the audit of the basic financial statements and, in our opinion, is fairly stated in all material respects in relation to the basic financial statements taken as a whole.

*Jones, Nale & Mattingly P.C.*

Louisville, Kentucky  
March 6, 2009



**EAST KENTUCKY NETWORK, LLC  
DBA APPALACHIAN WIRELESS**

**STATEMENTS OF INCOME DETAIL**

	Year Ended December 31, 2008				
	RSA #9 Appalachian	RSA #10 Mountaineer	Fiber Ring	PCS	Totals
<b>REVENUE</b>					
Retail	\$21,677,148	\$ 13,716,884	\$ --	\$ 196,828	\$35,590,860
Roamer	9,424,434	3,125,657	--	42,024	12,592,115
Long distance	131,994	81,285	--	1,017	214,296
Paging	259,547	307,130	--	--	566,677
Equipment sales, cellular	1,492,348	689,288	--	67,303	2,248,939
Equipment sales, paging	20,869	14,908	--	--	35,777
Other	3,903,116	2,387,648	1,559,075	67,058	7,916,897
Total revenue	<u>\$36,909,456</u>	<u>\$ 20,322,800</u>	<u>\$ 1,559,075</u>	<u>\$ 374,230</u>	<u>\$59,165,561</u>
<b>EXPENSES</b>					
Cost of cellular service	\$ 7,464,380	\$ 5,305,238	\$ --	\$ 92,285	\$12,861,903
Cost of paging service	148,346	184,040	--	--	332,386
Cost of equipment sales, cellular	6,730,198	4,590,695	--	335,474	11,656,367
Cost of equipment sales, paging	24,309	32,396	--	--	56,705
Customer service	813,941	496,602	--	2,490	1,313,033
Billing	873,600	505,623	--	3,898	1,383,121
Selling	2,134,116	1,595,634	--	1,455	3,731,205
Maintenance	1,035,157	697,495	39,468	66,820	1,838,940
Utilities	391,910	254,462	43,330	21,744	711,446
Bad debts	491,883	302,032	--	8,243	802,158
Cell site rental	133,339	88,571	400	15,230	237,540
Taxes and licenses	576,748	250,317	121,722	16,540	965,327
Advertising	2,084,232	771,388	--	112,570	2,968,190
General and administrative	1,802,346	1,056,315	226,927	20,792	3,106,380
Occupancy	102,054	80,815	208,497	12,434	403,800
Depreciation	3,939,105	2,891,653	725,234	147,024	7,703,016
Amortization	211,208	407,992	22,151	29,113	670,464
Total expenses	<u>\$28,956,872</u>	<u>\$ 19,511,268</u>	<u>\$ 1,387,729</u>	<u>\$ 886,112</u>	<u>\$50,741,981</u>
Income from operations	<u>\$ 7,952,584</u>	<u>\$ 811,532</u>	<u>\$ 171,346</u>	<u>\$ (511,882)</u>	<u>\$ 8,423,580</u>
<b>OTHER INCOME (EXPENSE)</b>					
Interest income	\$ 21,154	\$ 31,375	\$ 3,331	\$ 163	\$ 56,023
Interest expense	(783,129)	(455,419)	--	(3,957)	(1,242,505)
Universal Service Fund income	3,340,349	3,340,349	--	--	6,680,698
	<u>\$ 2,578,374</u>	<u>\$ 2,916,305</u>	<u>\$ 3,331</u>	<u>\$ (3,794)</u>	<u>\$ 5,494,216</u>
Net income (loss)	<u>\$10,530,958</u>	<u>\$ 3,727,837</u>	<u>\$ 174,677</u>	<u>\$ (515,676)</u>	<u>\$13,917,796</u>

Year Ended December 31, 2007

RSA #9 Appalachian	RSA #10 Mountaineer	Fiber Ring	PCS	Totals
\$17,642,270	\$11,838,430	\$ --	\$ --	\$29,480,700
6,669,355	2,570,467	--	--	9,239,822
124,057	72,730	--	--	196,787
311,459	372,605	--	--	684,064
1,858,283	1,147,890	--	--	3,006,173
22,375	11,487	--	--	33,862
<u>1,918,184</u>	<u>1,393,323</u>	<u>1,202,262</u>	--	<u>4,513,769</u>
<u>\$28,545,983</u>	<u>\$17,406,932</u>	<u>\$ 1,202,262</u>	<u>\$ --</u>	<u>\$47,155,177</u>
\$ 5,269,638	\$ 3,740,533	\$ --	\$ --	\$ 9,010,171
144,051	165,473	--	--	309,524
6,159,530	3,818,719	--	--	9,978,249
32,491	26,816	--	--	59,307
854,848	569,349	--	--	1,424,197
646,609	439,931	--	--	1,086,540
1,488,778	1,271,924	--	--	2,760,702
947,194	605,128	41,911	3,109	1,597,342
317,027	211,787	33,641	--	562,455
679,376	486,293	--	--	1,165,669
110,010	63,542	2,168	--	175,720
460,230	354,586	58,550	--	873,366
1,349,040	425,277	--	--	1,774,317
1,470,148	957,527	207,795	--	2,635,470
92,800	76,970	183,871	--	353,641
3,606,890	2,433,512	944,763	2,294	6,987,459
138,707	375,631	11,515	2,379	528,232
<u>\$23,767,367</u>	<u>\$16,022,998</u>	<u>\$ 1,484,214</u>	<u>\$ 7,782</u>	<u>\$41,282,361</u>
\$ 4,778,616	\$ 1,383,934	\$ (281,952)	\$ (7,782)	\$ 5,872,816
\$ 4,769	\$ 34,195	\$ 3,883	\$ --	\$ 42,847
(531,490)	(353,666)	--	--	(885,156)
<u>2,683,838</u>	<u>2,226,659</u>	<u>--</u>	<u>--</u>	<u>4,910,497</u>
<u>\$ 2,157,117</u>	<u>\$ 1,907,188</u>	<u>\$ 3,883</u>	<u>\$ --</u>	<u>\$ 4,068,188</u>
\$ 6,935,733	\$ 3,291,122	\$ (278,069)	\$ (7,782)	\$ 9,941,004

**EAST KENTUCKY NETWORK, LLC  
DBA APPALACHIAN WIRELESS**

**STATEMENTS OF INCOME DETAIL (Continued)**

	Year Ended December 31, 2008				
	RSA #9 Appalachian	RSA #10 Mountaineer	Fiber Ring	PCS	Totals
<b>COST OF CELLULAR SERVICE</b>					
Roamer pass through charges	\$ 4,949,474	\$ 3,595,547	\$ --	\$ 77,604	\$ 8,622,625
SCB interconnection	237,395	144,905	--	532	382,832
Local charges	2,401,115	1,387,166	--	18,826	3,807,107
Harold interconnection	134,062	--	--	--	134,062
Wheelwright interconnection	37,412	--	--	--	37,412
GTE interconnection	62,621	63,402	--	--	126,023
West Liberty interconnection	46,578	--	--	--	46,578
Chapman interconnection	67,775	21,616	--	161	89,552
Salyersville interconnection	154,146	82,148	--	658	236,952
Bluefield interconnection	300	--	--	--	300
Roanoke interconnection	13,626	--	--	--	13,626
Interconnect revenue	(715,726)	(453,368)	--	(5,653)	(1,174,747)
Fiber ring interconnection	75,602	121,000	--	157	196,759
TGTC interconnection and DS3 charges	--	171,590	--	--	171,590
PRTC interconnection	--	171,232	--	--	171,232
	<u>\$ 7,464,380</u>	<u>\$ 5,305,238</u>	<u>\$ --</u>	<u>\$ 92,285</u>	<u>\$12,861,903</u>
<b>COST OF PAGING SERVICE</b>					
Paging maintenance	\$ 256	\$ 384	\$ --	\$ --	\$ 640
Salaries and benefits	30,752	46,129	--	--	76,881
Tower rent	45,095	75,005	--	--	120,100
Telephone expense	--	131	--	--	131
Expanded coverage costs	--	998	--	--	998
Interconnection charges	33,211	28,094	--	--	61,305
Office and billing expense	38,462	22,945	--	--	61,407
Other	570	10,354	--	--	10,924
	<u>\$ 148,346</u>	<u>\$ 184,040</u>	<u>\$ --</u>	<u>\$ --</u>	<u>\$ 332,386</u>

Year Ended December 31, 2007

RSA #9 Appalachian	RSA #10 Mountaineer	Fiber Ring	PCS	Totals
\$ 3,554,926	\$ 2,559,114	\$ --	\$ --	\$ 6,114,040
234,187	158,145	--	--	392,332
1,496,116	991,910	--	--	2,488,026
166,140	--	--	--	166,140
31,134	--	--	--	31,134
18,186	33,187	--	--	51,373
107,242	--	--	--	107,242
43,298	16,620	--	--	59,918
118,167	64,495	--	--	182,662
2,976	--	--	--	2,976
14,629	--	--	--	14,629
(569,849)	(393,685)	--	--	(963,534)
52,486	71,881	--	--	124,367
--	186,290	--	--	186,290
--	52,576	--	--	52,576
<u>\$ 5,269,638</u>	<u>\$ 3,740,533</u>	<u>\$ --</u>	<u>\$ --</u>	<u>\$ 9,010,171</u>

\$ 3,966	\$ 6,718	\$ --	\$ --	\$ 10,684
28,850	43,351	--	--	72,201
44,798	53,146	--	--	97,944
--	126	--	--	126
--	703	--	--	703
35,618	27,865	--	--	63,483
30,566	22,507	--	--	53,073
254	11,056	--	--	11,310
<u>\$ 144,052</u>	<u>\$ 165,472</u>	<u>\$ --</u>	<u>\$ --</u>	<u>\$ 309,524</u>



## DIRECTIONS TO THE CORDIA SITE

Beginning on Main Street (Rt 550) in front of the Knott County Courthouse, Hindman, KY, go East on Rt. 550 0.2 miles to the junction of Rt. 160 West.

Turn left (West) on Rt. 160 and go 1.3 miles to the junction of U.S. Rt. 80.

Turn left (West ) on Rt. 80 and go 11.9 miles.

Turn left on Rt. 1146 and go 1.2 miles to the junction of Rt. 476.

Turn right on Rt. 476 and go 1.2 miles.

Turn left on Rt. 1088 and go 4.9 miles to the junction of Clear Fork Road.

Turn left on Clear Fork Road and go 0.2 miles. The road to the tower will begin on the right. This road is not complete but the route is flagged with blue and white ribbons.

Total miles to this point are 20.9.

Directions given by:

Dennis Shepherd  
Appalachian Wireless  
606-791-6263 Cell Phone  
606-785-2215 Office  
[d.shepherd@tgtel.com](mailto:d.shepherd@tgtel.com) email

# Search Area Map

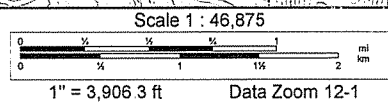
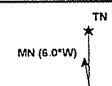
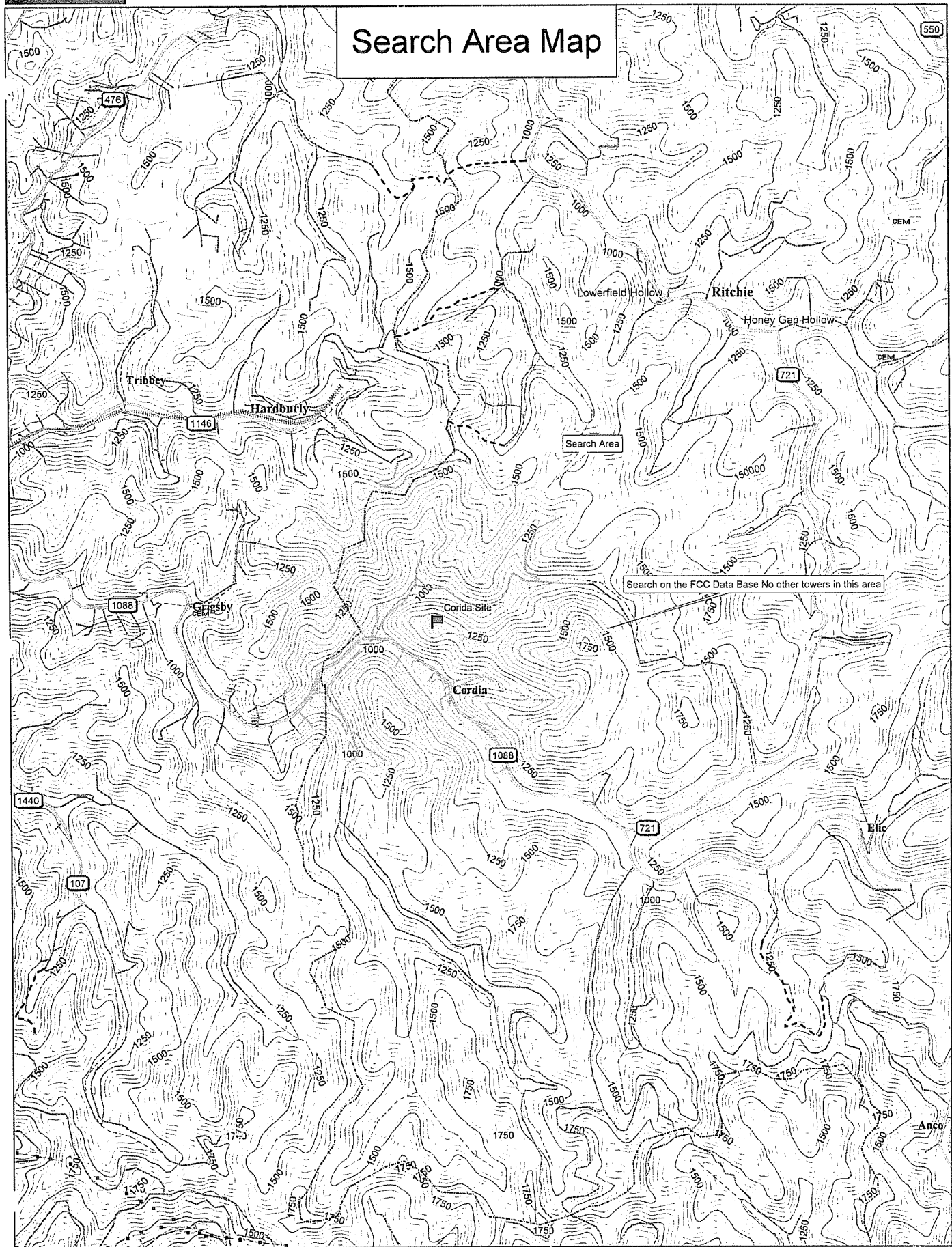





**DEED AND EASEMENT**

**THIS DEED AND EASEMENT** is made and entered into this 18<sup>th</sup> day of January, 2008, by and between **J.B. SINGLETON** and his wife, **ANGIE SUE SINGLETON**, residents of 3129 Lotts Creek Road, Hazard, Kentucky 41701; **JOE SINGLETON** and his wife, **FAYETTA SINGLETON**, residents of 2482 McCauly Road, Wilmore, Kentucky 40390; **DELORES SMITH** and her husband, **SAMMY SMITH**, residents of 2972 N. Main Street, Hazard, Kentucky 41701; and, **HOWARD OWENS** and his wife, **GEORGIA OWENS**, residents of 39 Clear Fork Road, Hazard, Kentucky 41701, all parties of the first part (hereinafter "Grantors"); and **EAST KENTUCKY NETWORK, LLC, dba APPALACHIAN WIRELESS**, having a mailing address of 101 Technology Trail, Ivel, Kentucky 41642, party of the second part (hereinafter "Grantee").

**WITNESSETH:**

For and in consideration of the total sum of Twenty Thousand Dollars (\$20,000.00), cash in hand paid, Grantors have bargained and sold and by these presents do hereby bargain, sell, grant and convey in fee unto Grantee, its successors and assigns forever, a certain tract of land located on the Clear Fork of Lotts Creek in Knott County, Kentucky, as more particularly described in Exhibit "A" attached hereto and incorporated fully herein by reference (hereinafter referred to as the "EKN Tract").

**Source of Title to EKN Tract:** Being a part of the same property conveyed by Oza Patrick, et al, to Mattie Singleton by deed dated June 29, 1955 and recorded at Deed Book 80, page 112 in the Knott County Clerk's Office. Mattie Singleton subsequently conveyed a ½ undivided interest in the property

jointly to Howard Owens and Georgia Owens by deed dated February 7, 2001 and recorded at Deed Book 199, page 506 in the Knott County Clerk's Office. Under the terms of the Will of Mattie Singleton, recorded at Will Book 18, page 716 in the Knott County Clerk's Office, her remaining ½ undivided interest in the property passed to J.B. Singleton, Joe Singleton and Delores Smith. That portion of Grantors' property (as described in the foregoing deeds recorded at Deed Book 80, page 112 and Deed Book 199, page 506 in the Knott County Clerk's Office) not comprising the EKN Tract is hereinafter referred to as "Grantors' Remaining Property".

**EASEMENT RIGHTS:** Grantors do hereby further grant, bargain, sell and convey unto Grantee, its successors and assigns, for the aforesaid consideration, the following easement rights:

**A. Roadway Easement:** A nonexclusive, permanent easement across Grantors' Remaining Property for the construction, maintenance and use of a roadway for purposes of ingress to and egress from the EKN Tract, the location of the roadway to be mutually determined by Grantors and Grantee. Grantee shall be solely responsible for the construction and maintenance of the roadway.

**B. Power Line Easement:** A nonexclusive, permanent easement across Grantors' Remaining Property, measuring approximately forty (40) feet in width, for the placement of power and telephone transmission lines to service the communications tower and related facilities to be located on the EKN Tract. The location of the power line easement shall be mutually determined by Grantors and Grantee. Grantee shall be solely responsible for the construction and

maintenance relating to the installation of the power and telephone transmission lines and related appurtenances.

The roadway easement rights and the power line easement rights granted to Grantee hereunder shall continue, uninterrupted, until such time as Grantee, or its successors and/or assigns, determine that such easement rights are no longer needed for the operation and maintenance of the communication facilities to be located on the EKN Tract.

**Source of Title to Easement:** The easement rights granted herein being across the remaining portion of Grantors' property described at Deed Book 80, page 112 and Deed Book 199, page 506, both of record in the Knott County Clerk's Office.

**TO HAVE AND TO HOLD** the same, together with all rights, privileges and appurtenances thereunto belonging unto Grantee, its successor and assigns forever, with covenants of **GENERAL WARRANTY**.

**CERTIFICATE OF PARTIES**

Grantors and Grantee do hereby certify, pursuant to KRS Chapter 382, that the above-stated consideration in the amount of Twenty Thousand Dollars (\$20,000.00) is the true, correct and full consideration paid for the property and easement rights herein conveyed. Grantors and Grantee further certify their understanding that falsification of the stated consideration or sale price of the property is a Class D felony, subject to one to five years imprisonment and fines up to \$10,000.00. Grantee is executing this deed solely for purposes of this certification. The in-care address to which the property tax bill for 2009 should be sent is: East Kentucky Network, LLC, dba Appalachian Wireless, 101 Technology Trail, Ivel, Kentucky 41642.

**IN TESTIMONY WHEREOF**, witness the signatures of Grantors and  
Grantee on this the day and year first above written.

**GRANTORS:**

  
J. B. SINGLETON

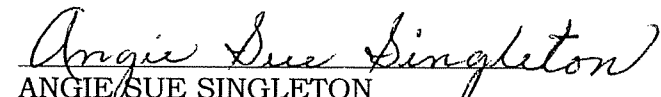
  
ANGIE/SUE SINGLETON

  
JOE SINGLETON

  
FAYETTA SINGLETON

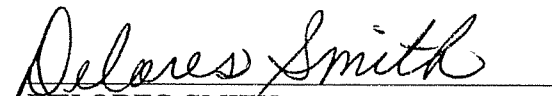
  
DELORES SMITH

  
SAMMY SMITH

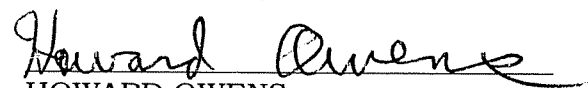
  
HOWARD OWENS

  
GEORGIA OWENS

**GRANTEE:**

EAST KENTUCKY NETWORK, LLC  
dba APPALACHIAN WIRELESS

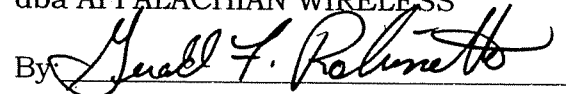
By 

Its: General Manager/CEO

STATE OF Kentucky

COUNTY OF Perry

I hereby certify that the foregoing deed and certificate of parties was produced to me and duly acknowledged, subscribed and sworn to before me by J.B. SINGLETON and his wife, ANGIE SUE SINGLETON, to be their act and deed, on this the 19<sup>th</sup> day of January, 2008.

Dennis Shepherd  
Notary Public

My commission expires Oct. 22 - 2009.

STATE OF Kentucky

COUNTY OF Perry

I hereby certify that the foregoing deed and certificate of parties was produced to me and duly acknowledged, subscribed and sworn to before me by JOE SINGLETON and his wife, FAYETTA SINGLETON, to be their act and deed, on this the 19<sup>th</sup> day of January, 2008.

Dennis Shepherd  
Notary Public

My commission expires Oct. 22 - 2009.

STATE OF Kentucky

COUNTY OF Perry

I hereby certify that the foregoing deed and certificate of parties was produced to me and duly acknowledged, subscribed and sworn to before me by DELORES SMITH and her husband, SAMMY SMITH, to be their act and deed, on this the 19<sup>th</sup> day of January, 2008.

Dennis Shepherd  
Notary Public

My commission expires Oct. 22 - 2009.

STATE OF Kentucky

COUNTY OF Perry

I hereby certify that the foregoing deed and certificate of parties was produced to me and duly acknowledged, subscribed and sworn to before me by HOWARD OWENS and his wife, GEORGIA OWENS, to be their act and deed, on this the 19<sup>th</sup> day of January, 2008: 9

Dennis Shepherd  
Notary Public

My commission expires Oct: 22-2009.

STATE OF Kentucky

COUNTY OF Floyd

I hereby certify that the foregoing deed and certificate of parties was produced to me and duly acknowledged, subscribed and sworn to before me by Gerald F. Robinette, known to me to be the General Manager/CEO of EAST KENTUCKY NETWORK, LLC, dba APPALACHIAN WIRELESS, to be the act and deed of said entity, on this the 14 day of January, 2008: 2009

Teresa M. Opel  
Notary Public

My commission expires June 22, 2009.

This instrument prepared by:

Robin J. Collins  
ROBIN JOHNSON COLLINS  
Attorney at Law  
P.O. Box 176  
Lackey, Kentucky 41643  
(606)358-4493

**LEASE LOT DESCRIPTION**

Property of  
Mattie Singleton, Howard & Georgia Owens  
39 Clear Fork Road  
Hazard, KY 41701  
Near Cordia in Knott County  
October 9, 2008

A portion of the property lying within the tract of land located on Lotts Creek in Knott County Kentucky, near the community of Cordia. Being a part of the same land conveyed by deed from Oza Patrick et al. to Mattie Singleton by Deed dated June 29, 1955 and recorded in Deed Book 80 Page 112 of the Knott county Court Clerks office and also conveyed from Mattie Singleton to Howard & Georgia Owens by deed dated February 7, 2001 and recorded in Deed Book 199 Page 506 of the Knott County Court Clerks Office

Unless stated otherwise, any monument referred to herein as "set iron pin with cap" is a set ½" diameter rebar, at least eighteen (18") in length, with a plastic cap stamped "LS-2259". All bearings stated herein are referred to the NAD83 KY South State Plane Coordinate System. This survey preformed by James W. Caudill, LS2259, on October 9, 2008

Lease Lot A1

Beginning on a found 28" marked oak tree standing on a small knob on the ridge between Lotts Creek and Clear Fork of Lotts Creek, said tree being a corner common the the property of Mattie Singleton/Howard & Georgia Owens (Book 199 page 506), Tonya Engle & Tim Cody (Book 153 Page 356), Avanelle & Roger Eversole (Book 181 Page 942) and Sterling & Sherry Martin (Book 140 Page 109), thence leaving the top of the mountain and running over the hill toward Dark Hollow severing the property of Mattie singleton/Howard & Georgia Owens South 47 deg 24 min 07 sec West, 242.83 feet to a set iron pin with cap marked ls2259 on the hillside; thence running around the hill North 23 deg 36 min 23 sec West, 117.12 feet to a set iron pin with cap marked ls2259 on the hillside; thence running up the hill North 42 deg 12 min 45 sec East, 149.77 feet to a set iron pin with cap on the ridge between Lotts Creek and Clear Fork being a point on the line of Tonya Engle & Tim Cody Property; thence running with the line of Tonya Engle & Tim Cody and the ridge South 66 deg 41min 07 sec East, 136.14 feet in all to the beginning corner, passing over a set iron pin with cap marked ls2259 at 133.14 feet. Containing a calculated area of 23091 sq ft or 0.5 acres.

This survey was performed on October 9, 2008 by James W. Caudill, a Kentucky Licensed Professional Land Surveyor No. 2259.

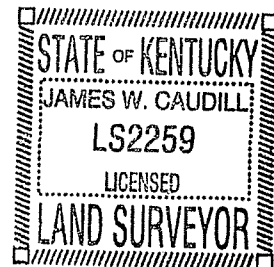

*James W. Caudill*  
James W. Caudill, PLS #2259

**STATE OF KENTUCKY**

**COUNTY OF KNOTT**

I, KENNITH GAYHEART, Clerk of Knott County, do hereby certify that the foregoing instrument was on the 20 day of Jan, 2008, lodged in my office for record and that it, the foregoing, and this my certificate have been duly recorded in my said office in Deed Book 245, page 693

Witness my hand on this the 20 day of Jan, 2008.

**KENNITH GAYHEART, CLERK**

By: Russ Hays D.C.

DEED TRANSFER TAX PAID  
\$ 20.00  
DATE 01-20-09 OH



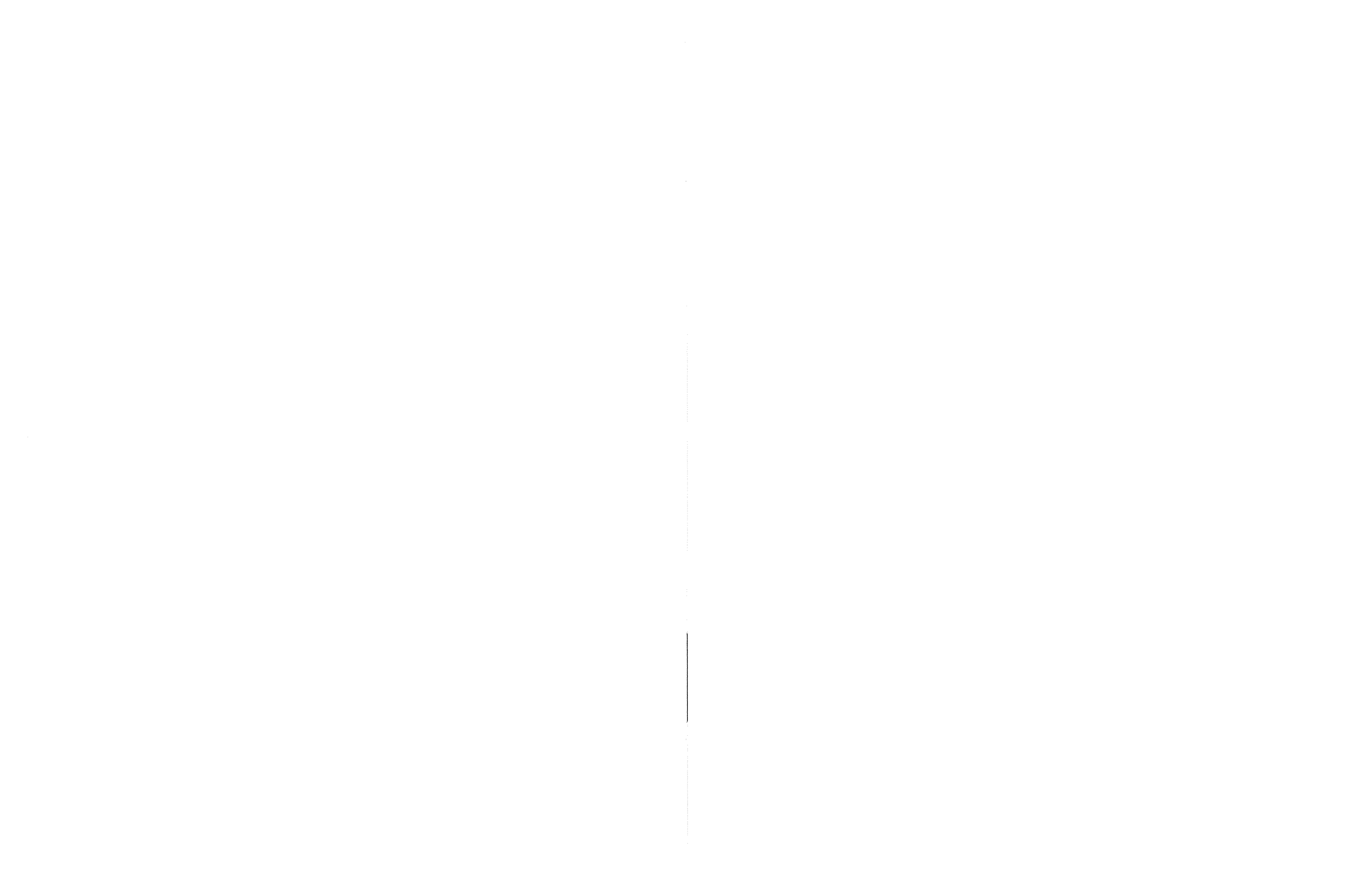

**SITE SURVEY  
STRUCTURE LOCATION  
SINGLETON/OWENS TRACT  
NEAR CORDIA IN KNOTT CO.**

**APPALACHIAN WIRELESS**  
101 TECHNOLOGY TRAIL  
IVEL, KY. 41642  
PROPOSED TOWER SITE  
SINGLETON/OWENS TRACT  
NEAR CORDIA IN KNOTT CO.

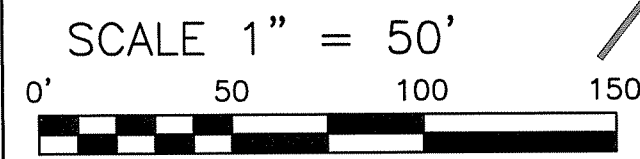
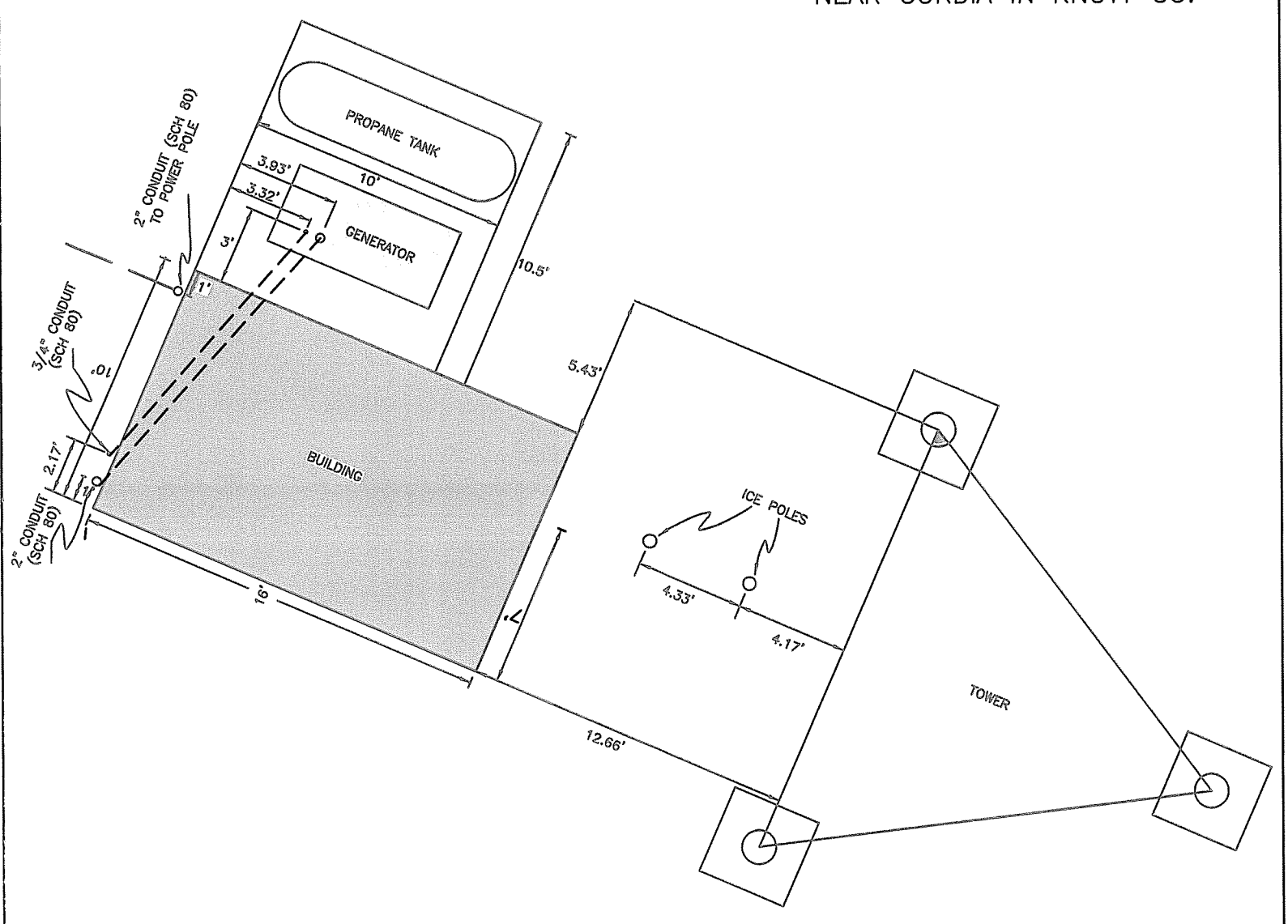
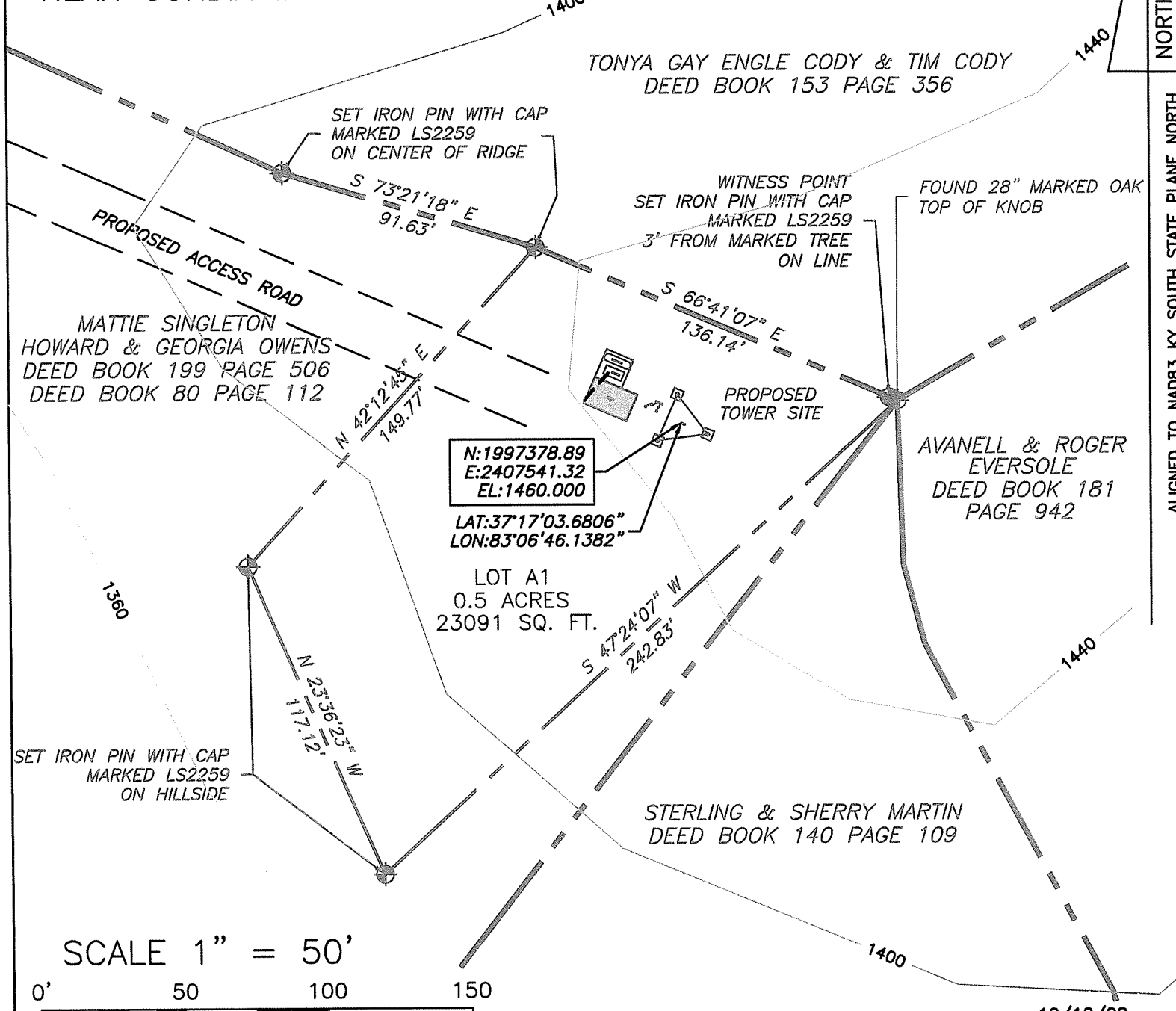

- LEGEND**
- SURVEY STA
  - BOUNDARY LINE
  - ACCESS ROAD
  - PARENT TRACT LINE

-THE PROPOSED TOWER HAS BEEN LOCATED USING DUAL FREQUENCY GPS UNIT PROCESSED BY "OPUS"  
 -STATE PLANE COORDINATES NAD 83 KY SOUTH ZONE N 1997378.89, E 2407541.32, EL 1460 FT MSL  
 -PRECISION: HORIZONTAL=0.30' VERTICAL=0.50'  
 -PROPERTY LINE INFORMATION TAKEN FROM DEEDS AND VERIFIED IN THE FIELD.

*James W. Caudill* 12305 10-10-08  
 JAMES W. CAUDILL P.E. DATE

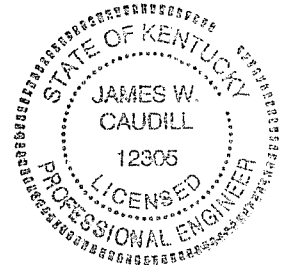

NOTE: \* USE SWEEPS IN CONDUIT FOR ALL TURNS  
 \* CONDUITS SHALL BE PLACED 3.25" OUTSIDE CONCRETE SLAB

**SITE SURVEY/STR LOCATION**

**COLEMAN ENGINEERING**

P.O. BOX 153, HINDMAN, KY 41822

CARRIE 7.5' QUADRANGLE

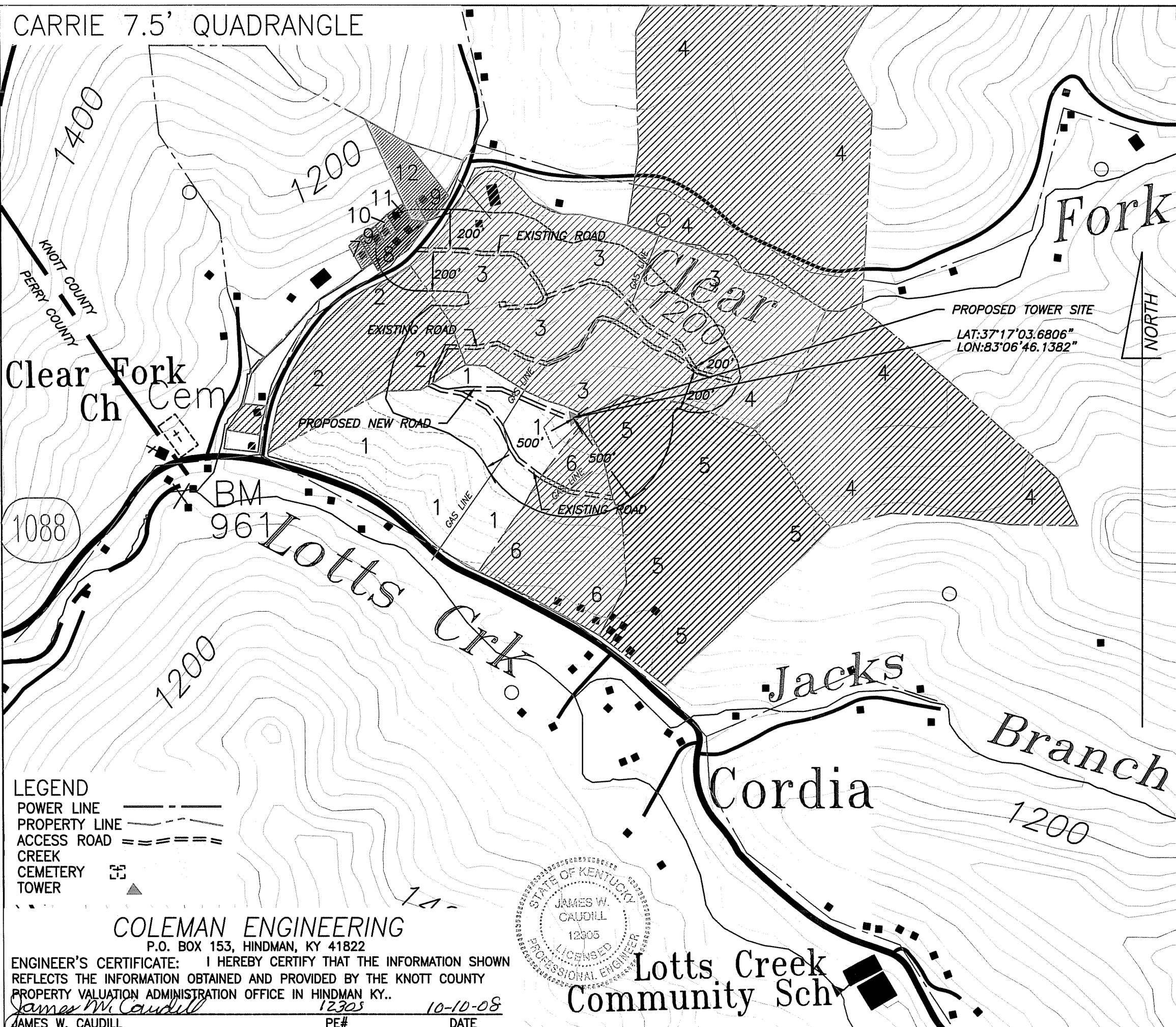

APPALACHIAN WIRELESS  
 101 TECHNOLOGY TRAIL  
 IVEL, KY. 41642  
 PROPOSED TOWER SITE  
 SINGLETON/OWENS TRACT  
 NEAR CORDIA IN KNOTT CO.

LAND OWNERS:

- |     |   |      |   |
|-----|---|------|---|
| ○ 1 | MATTIE SINGLETON<br>HOWARD & GEORGIA OWENS<br>5011 LOTTS CRK RD<br>HAZARD, KY 41701 | ● 7  | AUTHUR GAYHEART HEIRS<br>C/O GINA GAYHEART<br>P.O. BOX 484<br>BULAN, KY 41722 |
| ● 2 | HOWARD & GEORGIA OWENS<br>39 CLEAR FORK ROAD<br>HAZARD, KY 41701                    | ● 8  | OSCAR & SYBILM GRIGSBY<br>263 CLEAR FORK ROAD<br>LOTTS CREEK, KY 41701        |
| ● 3 | TOYNA ENGLE & TIM CODY<br>292 CLEAR FORK ROAD<br>LOTTS CREEK, KY 41701              | ● 9  | LLOYD & JETTA GAYHEART<br>RT2 BOX170 CLEAR FK RD<br>HAZARD, KY 41701          |
| ● 4 | ALVAH & DIANA SKAGGS<br>35 SPRING AVE<br>HAZARD, KY 41701                           | ● 10 | AMY ALLEN<br>141 CLEAR FORK ROAD<br>LOTTS CREEK, KY 41701                     |
| ● 5 | ROGER EVERSELE<br>5411 LOTTS CREEK ROAD<br>HAZARD, KY 41701                         | ● 11 | DEXTER & ALMA LITTLE<br>233 CLEAR FORK ROAD<br>HAZARD, KY 41701               |
| ● 6 | STERLING & SHERRY MARTIN<br>P.O. BOX 403<br>BULAN, KY 41722                         | ● 12 | WILLIAM FELTNER<br>309 CLEAR FORK ROAD<br>HAZARD, KY 41701                    |

LEGEND  
 POWER LINE ———  
 PROPERTY LINE - - - -  
 ACCESS ROAD = = = =  
 CREEK  
 CEMETERY ☒  
 TOWER ▲

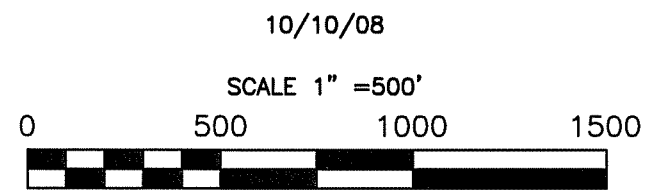

COLEMAN ENGINEERING  
 P.O. BOX 153, HINDMAN, KY 41822  
 ENGINEER'S CERTIFICATE: I HEREBY CERTIFY THAT THE INFORMATION SHOWN  
 REFLECTS THE INFORMATION OBTAINED AND PROVIDED BY THE KNOTT COUNTY  
 PROPERTY VALUATION ADMINISTRATION OFFICE IN HINDMAN KY..  
*James W. Caudill* 12305 10-10-08  
 JAMES W. CAUDILL PE# DATE

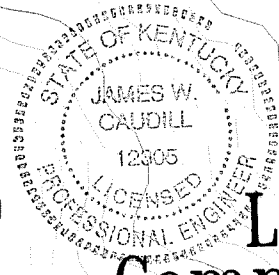

Lotts Creek  
 Community Sch

MAP SHOWING STRUCTURES & LAND OWNERS  
 WITHIN 500 FT OF THE PROPOSED TOWER

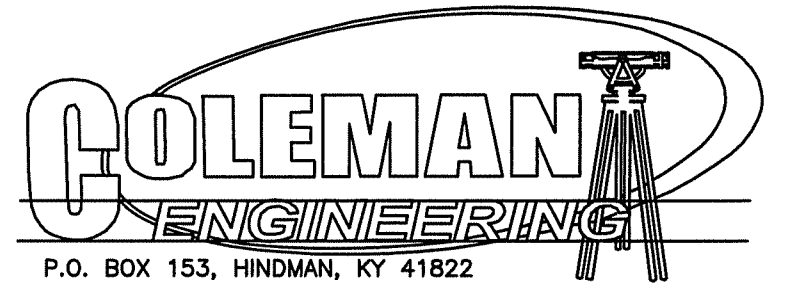



APPALACHIAN WIRELESS  
101 TECHNOLOGY TRAIL  
IVEL, KY. 41642

PROPOSED TOWER SITE  
SINGLETON/OWENS TRACT  
NEAR CORDIA IN KNOTT COUNTY

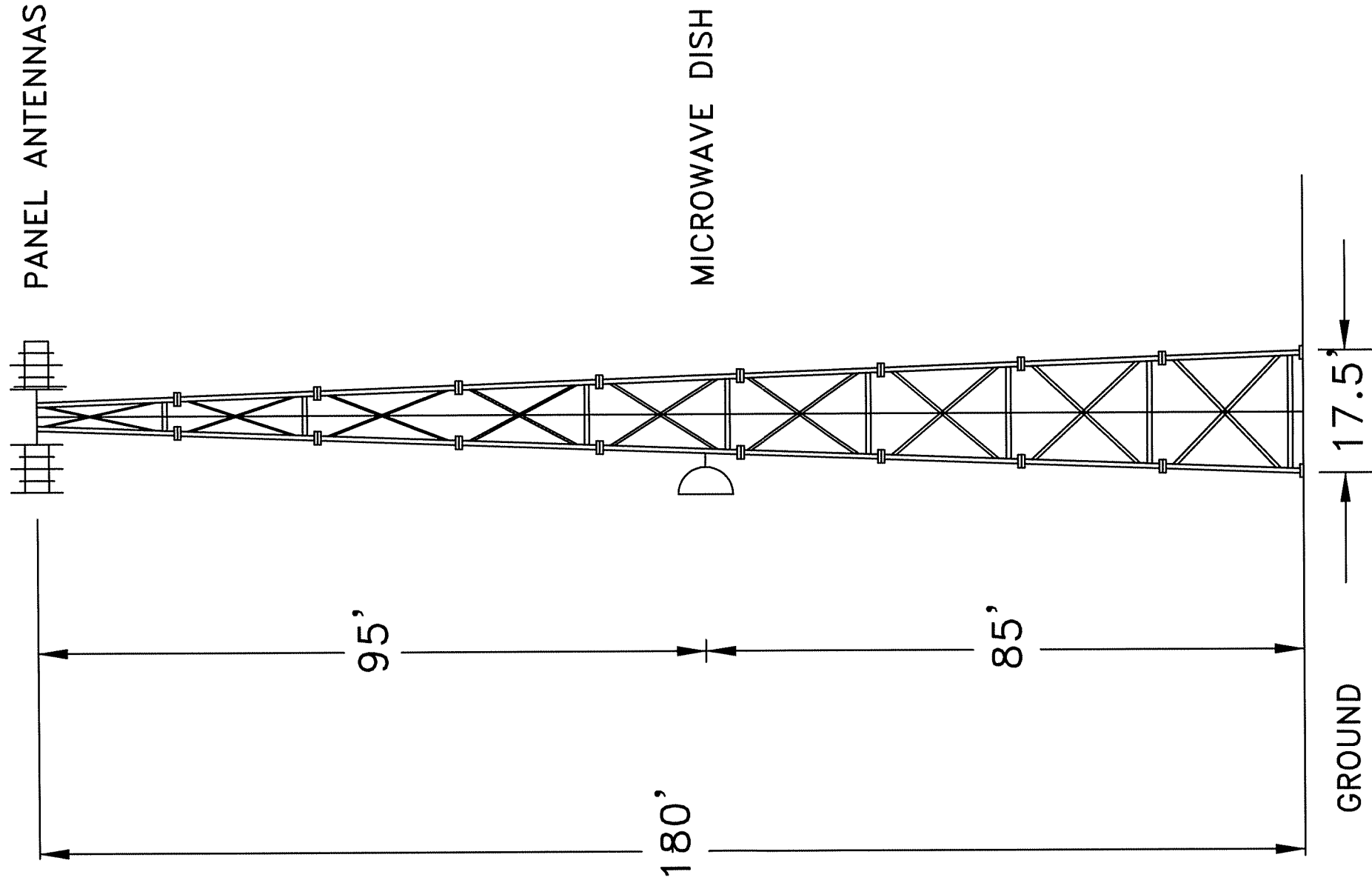

GRAPHIC SCALE



THIS IS A VERTICAL PROFILE SKETCH OF THE TOWER INDICATING THE PROPOSED ANTENNA AND DISH ELEVATIONS. NO DESIGN CRITERIA WAS CONSIDERED IN THE PREPARATION OF THIS DRAWING.

*James W. Caudill* 12305 10-10-08  
JAMES W. CAUDILL P.E. DATE

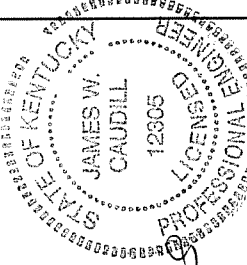

VERTICAL PROFILE SKETCH

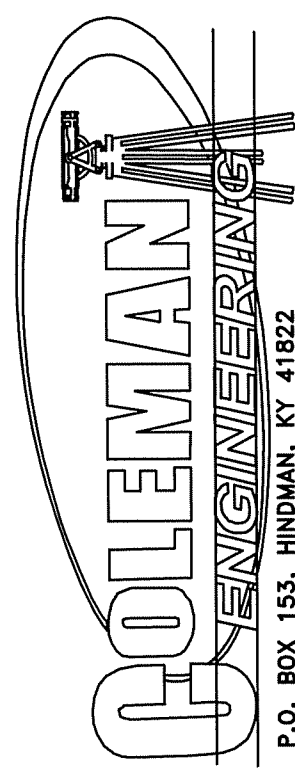

10/10/08