

DORSEY, KING, GRAY, NORMENT & HOPGOOD

ATTORNEYS-AT-LAW

318 SECOND STREET

HENDERSON, KENTUCKY 42420

JOHN DORSEY (1920-1986)  
FRANK N. KING, JR.  
STEPHEN D. GRAY  
WILLIAM M. NORMENT, JR.  
J. CHRISTOPHER HOPGOOD  
S. MADISON GRAY

TELEPHONE  
(270) 826-3965  
TELEFAX  
(270) 826-6672  
www.dkgnlaw.com

June 24, 2009

FEDEX

RECEIVED

JUN 25 2009

PUBLIC SERVICE  
COMMISSION

Mr. Jeff DeRouen  
Executive Director  
Public Service Commission  
211 Sower Boulevard, Post Office Box 615  
Frankfort, Kentucky 40602-0615

Re: Case No. 2009-00186  
Kenergy Corp. special contracts –  
Agreement for Retail Electric Service with Southwire Company;  
Letter Agreement for Wholesale Service with Big Rivers Electric  
Corporation

Dear Mr. DeRouen:

On April 24, 2009, Kenergy Corp. (“Kenergy”) filed proposed unexecuted wholesale and retail service agreements in this matter. The Commission was informed that Kenergy and Big Rivers Electric Corporation (“Big Rivers”) were in agreement with the terms of the wholesale agreement, but that Southwire Company (“Southwire”) had not given its consent to the terms of the retail agreement. Kenergy sought approval of the agreements in contemplation that an agreement could be reached with Southwire on the terms stated in the proposed retail agreement, or on substantially similar terms.

The filing requested the notice period to be shortened to 20 days and on May 15, 2009, the Commission entered an order denying that request, noting that the documents were unexecuted and contained provisions that had not been agreed to by the parties. On May 22, 2009, the Commission entered order suspending the service agreements for five (5) months, being up to and including October 23, 2009.

Kenergy is now pleased to inform the Commission that these parties have reached agreement regarding rates and service to Southwire following a

closing of the Unwind Transaction (Case No. 2007-00455). Enclosed herewith for filing please find the following:

- June 23, 2009 version of Agreement for Retail Electric Service, unmarked (“Retail Agreement”);
- June 23, 2009 version of the Retail Agreement, marked against the version of the Retail Agreement filed with the Commission on April 24, 2009;
- June 23, 2009 version of the Wholesale Letter Agreement, unmarked; and
- June 23, 2009 version of the Wholesale Letter Agreement, marked against the version of the Wholesale Letter Agreement filed with the Commission on April 24, 2009.

The changes in the Retail Agreement since April 24, 2009, are largely to correct typographical errors, cross references and defined terms. Section 2.05(d) was deleted as redundant. The floor of 3,000 kW on the minimum billing demand found in Section 3.03(b) has been deleted. The minimum billing demand will be 60% of the Maximum Contract Demand as established under Section 2.03.

The changes to the Wholesale Letter Agreement conform that document with the terms of the Retail Agreement to recognize circumstances related to the contemplated changes in the delivery point and metering point after the Retail Contract becomes effective. It also acknowledges that if Southwire makes a cash deposit to secure payment of the Transmission Facilities Costs, the party that holds the deposit will be responsible for the legal obligations associated with holding a utility customer deposit.

Further enclosed is a copy of the Delivery Point Agreement referred to in the Retail Agreement. Kenergy, Big Rivers and Southwire are in agreement with its terms but Century Aluminum of Kentucky General Partnership (“Century”) has not yet given its approval to the terms. The Delivery Point Agreement establishes terms by which Century and Southwire give Kenergy and its wholesale power supplier, Big Rivers, permission to use the Century delivery point to deliver retail service to Southwire until a new delivery point is established. While the Southwire Retail Agreement gives Southwire an option to establish an alternate delivery point, please note that, as reflected in the Delivery Point Agreement, Southwire has already elected that option. The Delivery Point

Agreement also establishes a protocol for Kenergy to follow if it is required to exercise the remedy of disconnecting service to either Century or Southwire.

Kenergy and Big Rivers believe the Delivery Point Agreement does not change the proposed agreements for retail service with either Southwire or Century, but is a non-jurisdictional resolution of practical issues related to use by Kenergy and Big Rivers on a temporary basis of facilities owned by Century. Kenergy would note that electric service to Southwire is currently delivered at the Century delivery point.

The documents enclosed herewith will need to be executed at the closing of the Unwind Transaction. Kenergy accordingly requests that the Commission issue an order accepting the Southwire Retail Agreement and the Wholesale Letter Agreement, terminating the suspension period and finding that the Delivery Point Agreement does not require Commission acceptance or approval.

Please contact the undersigned with any questions. Your assistance in this matter is appreciated.

Very truly yours,

DORSEY, KING, GRAY, NORMENT & HOPGOOD

By

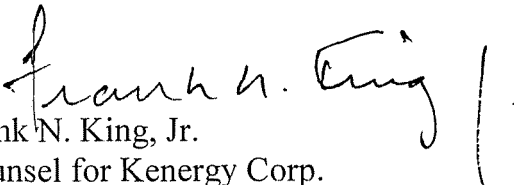
  
Frank N. King, Jr.  
Counsel for Kenergy Corp.

FNKJr/cds  
Encls.

COPY/w/encls.: (regular mail and electronic)

Hon. John C. Stephens, Southwire Company General Counsel  
Mr. David Spainhoward, Big Rivers Electric Corporation  
Hon. James Miller, Big Rivers Electric Corporation General Counsel  
Mr. David Hamilton, Kenergy Corp.  
Mr. Russell Klepper, Consultant for Southwire Company and Century Aluminum of Kentucky General Partnership  
Hon. Richard Raff, Public Service Commission Staff Counsel

AGREEMENT FOR RETAIL ELECTRIC SERVICE

THIS AGREEMENT FOR ELECTRIC SERVICE ("Agreement"), is made and entered into as of the \_\_\_\_ day of July, 2009, by and between KENERGY CORP., a Kentucky electric cooperative corporation, with its principal office located at 6402 Old Corydon Road, P.O. Box 18, Henderson, Kentucky 42419-0018 (hereinafter, the "Seller"), and SOUTHWIRE COMPANY, a Delaware corporation, with its principal office located at One Southwire Drive, Carrollton, GA 30119 (hereinafter, the "Customer") (Seller and Customer are individually referred to herein as a "Party" and collectively as the "Parties").

WHEREAS, Customer and Green River Electric Corporation ("GREC"), Seller's predecessor in interest, entered into an Agreement for Electric Service dated July 15, 1998, (as amended, the "1998 Retail Agreement"), and related agreements, under which GREC agreed to supply electric service to Customer for use at Customer's primary aluminum smelter ("Smelter") and Customer's adjacent rod and cable mill ("Rod and Cable Mill"), both located in Hancock County, Kentucky;

WHEREAS, effective as of April 1, 2001, pursuant to a certain Stock Purchase Agreement dated August 31, 2000, between Century Aluminum Company ("Century") and Customer, Century acquired all of the issued and outstanding capital stock of certain subsidiaries of Customer that together owned all of the partnership interests of NSA, L.P., an indirect wholly owned subsidiary of Customer that, in turn, owned and operated the Smelter. Under a Master Assignment Agreement between Customer and Century dated November 22, 2000, as amended, Customer partially assigned its rights and interests under the 1998 Retail Agreement and related agreements to Century, except that Customer retained such rights and interests as necessary for it to continue to acquire electric service for use at its Rod and Cable Mill, with Century acting as Customer's agent for the limited purpose of facilitating Customer's acquisition of electric service for the Rod and Cable Mill;

WHEREAS, Seller and Big Rivers Electric Corporation ("Big Rivers"), Seller's wholesale power supplier, have amended the wholesale power agreements between them (the "2009 Wholesale Power Agreement Amendment") to establish the terms on which Big Rivers will supply electric service to Seller for Seller to resell to Customer under this Agreement for use at Customer's Rod and Cable Mill; and

WHEREAS, the Parties wish to enter into this new Agreement under which Seller will provide the exclusive source of electric service to Customer for use at the Customer's Rod and Cable Mill, which new Agreement replaces and supersedes any and all other agreements between the Parties, or between a Party and any third party for retail electric service to Customer;

NOW, THEREFORE, in consideration of the mutual covenants contained herein, the Parties agree as follows:

RECEIVED

JUN 25 2009

PUBLIC SERVICE  
COMMISSION

ARTICLE I  
GENERAL OBLIGATIONS

1.01 Basic Obligations of the Parties. Seller will supply, sell, and deliver to Customer, and Customer will accept and pay for, all of the electric power and energy required by Customer for the operation of its Rod and Cable Mill, up to the Maximum Contract Demand (as defined in Section 2.03 below). This service will be supplied under this Agreement, and the rules, regulations, and orders of the Public Service Commission of Kentucky ("Commission"), which may be applicable and effective from time to time. Seller and Customer agree that this Agreement and the Delivery Point Agreement (the "Delivery Point Agreement," that will be entered into as contemplated in this Section 1.01) contain the exclusive terms and conditions on which Seller will provide retail electric service to Customer during the term of this Agreement. The obligation of Seller to commence delivery of electric power and energy under this Agreement is contingent upon, and shall be postponed until Seller, Big Rivers, Customer and Century have executed a Delivery Point Agreement that provides for delivery of power and energy hereunder at the Existing Delivery Point (as defined in Section 2.01(a)) in form and substance acceptable to each of those parties.

1.02 Membership. Customer has been and shall continue to be a member of Seller, and shall be bound by such rules and regulations as may be adopted from time to time by Seller consistent with the terms and conditions of this Agreement.

ARTICLE II  
SERVICE CHARACTERISTICS

2.01 Delivery Point. The "Delivery Point" of the electric power and energy made available under this Agreement shall be the point at which Customer's facilities connect to Seller's facilities, or facilities designated by Customer, and is more specifically defined below as either the "Existing Delivery Point" or the "Prospective Delivery Point."

(a) The Delivery Point on the Effective Date of this Agreement, as defined in Section 11.02, shall be the "Existing Delivery Point," as defined and described in Section 2.01(c), below. The electric power and energy delivered to the Existing Delivery Point will be in the form of three-phase alternating current (60 hertz) at the nominal 161,000 voltage level.

(b) Upon notice from Customer, Seller and Big Rivers agree to proceed with all reasonable dispatch with the construction of distribution and transmission facilities required to establish a new and separate dedicated point of delivery from Kenergy to the Rod and Cable Mill (the "Prospective Delivery Point"), as further described in Exhibit A, attached hereto, that does not utilize either the Existing Delivery Point or the Southwire Interconnection (as defined and described in Section 2.01(c), below). Customer shall be responsible for the costs of construction of those distribution and transmission facilities as provided in Section 3.06 of this Agreement. Beginning with the date of commercial operation of the Prospective Delivery Point, the Prospective Delivery Point shall become the Delivery Point under this Agreement. The electric power and energy delivered to the Prospective Delivery Point will be in the form of three-phase alternating current (60 hertz) at the nominal 13,800 voltage level.

(c) For purposes of this Agreement the terms (i) “Existing Delivery Point” shall mean the existing set of meters at Big Rivers’ Coleman substation through which both the Smelter and the Rod and Cable Mill accept electric service; and (ii) “Southwire Interconnection” shall mean the physical assets owned by Century through which electric power and energy is both transformed and delivered from the Existing Delivery Point to the existing set of meters at which the Rod and Cable Mill currently accepts electric service at the 13,800 voltage level.

2.02 Service Restriction. Customer shall not use the electric power and energy furnished hereunder as an auxiliary or supplement to any other source of purchased power and shall not sell any electric power and energy purchased hereunder.

2.03 Maximum Contract Demand.

(a) The initial maximum demand of Customer during the term of this Agreement, or any extension thereof, shall be 6,800 kilowatts (the “Maximum Contract Demand”), unless increased or decreased as permitted under Section 2.03(b), or otherwise agreed in writing by the Parties. Seller shall not be obligated to supply capacity in excess of said demand, measured as specified in Section 3.03(a) of this Agreement; provided, however that if Customer modifies or expands its plant in such a way as to increase its electric requirements, Customer shall be entitled to obtain additional service, so long as the increase is in compliance with Seller’s rules and regulations filed with and approved by the Commission.

(b) The Maximum Contract Demand may be unilaterally increased or decreased by Customer, from time to time, up to a maximum of 10,000 kW or to a minimum of 3,000 kW by giving written notice to Seller at least 60 days prior to the effective date of the increase or decrease. For purposes of Seller’s Rate Schedule 41 and Big Rivers’ Rate Schedule 10, the parties agree that 4,575 kW is Customer’s Base Year peak demand. The effective date of any unilateral increase or decrease by Customer in its Maximum Contract Demand shall be the first day of a calendar month.

(c) The Maximum Contract Demand shall be measured as the highest integrated kilowatt demand occurring during a thirty-minute period at the beginning and mid-point of a clock hour in the billing month, as measured by the coincidental sum of Customer’s meters.

2.04 System Disturbances; Obligation For Damages.

(a) A “System Disturbance” shall be deemed to exist if the use of power by Customer directly or indirectly results in a risk of harm to human beings or material damage to or substantial interference with the functioning of Big Rivers’ generating system or transmission system, Seller’s distribution system, or the plant, facility, equipment or operations of any customer of one of Big Rivers’ distribution cooperatives. A System Disturbance includes, but is not limited to: (i) a level of current harmonic total demand distortion (“TDD”) measured at the Delivery Point that exceeds the limits on TDD described in IEEE Standard 519, Section 10; and

(ii) a use of capacity and energy in such a manner that causes a current imbalance between phases greater than five percent (5%) at the Delivery Point.

(b) In its role as control area operator and reader of the meters serving Seller, Big Rivers shall have primary responsibility for determining the existence and source of System Disturbances. If Big Rivers reasonably believes that Customer is responsible for a System Disturbance, it shall provide notice to Seller and Customer, and Customer may take, but shall not be obligated to take, appropriate action at its sole expense to cure, correct or suppress such System Disturbance. If the Customer declines for any reason to take action to correct the System Disturbance, then Seller shall undertake, or cause Big Rivers to undertake, appropriate action to cure, correct or suppress such System Disturbance. Customer shall be obligated to reimburse Seller for all costs incurred by Seller or Big Rivers to cure, correct or suppress such System Disturbance, provided that such action was successful in curing, correcting or suppressing such System Disturbance, and further providing that Customer is conclusively determined to be the cause of such System Disturbance.

(c) Customer acknowledges and agrees that Seller shall have no responsibility for damage to any property, or to any equipment or devices connected to Customer's electrical system on Customer's side of the Delivery Point that results solely from acts or omissions of Customer, its employees, agents, contractors or invitees, or malfunction of any equipment or devices connected to Customer's electrical system on Customer's side of the Delivery Point.

#### 2.05 Power Factor

(a) Pursuant to the 1998 Retail Agreement, with respect to the Rod and Cable Mill, Customer made certain payments to Seller and Big Rivers as compensation for an entitlement to 4,000 kilovars for the purpose of financially mitigating the reactive demand at the Rod and Cable Mill in excess of the reactive demand, measured in kilovars, to which Customer otherwise would be entitled without further compensation based on the Customer's maximum monthly demand and a power factor of ninety percent (90%). As a continuation of such entitlement, the Parties acknowledge that under this Agreement, Customer shall receive up to 4,000 kilovars per month without further compensation from Customer to Seller. For purposes of Section 2.05(b) below, each calculation of Customer's power factor, including the power factor for purposes of the formula set forth at the end of Section 2.05(b), shall reflect the Customer's monthly maximum metered kilovar demand, less 4,000 kilovars.

(b) Subject to Customer's entitlement to 4,000 kilovars per month as set forth in Section 2.05(a) of this Agreement, Customer shall maintain a power factor at the Delivery Point as nearly as practicable to unity. Power factor during normal operation may range from unity to ninety percent (90%). If Customer's power factor is less than 90% at time of maximum load, after adjusting for Customer's entitlement to 4,000 kilovars, Seller reserves the right to require Customer to choose either (a) installation at Customer's expense of equipment which will maintain a power factor of 90% or higher; or (b) adjustment of the maximum monthly metered demand for billing purposes in accordance with the following formula:

$$\text{Maximum Actual Measured Kilowatts} \times 90\%$$

Power Factor (%)(as adjusted)

2.06 Metering.

(a) The metering equipment necessary to register the electric demand and energy for this service shall be furnished, installed, operated, and maintained by Seller or Big Rivers on behalf of Seller, and shall be and remain the property of Seller or Big Rivers.

(b) Each meter shall be read on or about the first day of each month, or such other day as may be mutually agreed upon by a representative of Seller and Customer, and may be simultaneously read by a representative of Customer should Customer so elect. Customer agrees that during the period that the Delivery Point is the Existing Delivery Point, meter readings shall, for billing purposes, be grossed up as stated in Section 2.06(e), below.

(c) All inspections and testing of metering equipment shall be performed in accordance with applicable rules and regulations of the Commission.

(d) The metering point shall be at the Southwire Metering Point, as described in Section 2.06(e), below, at the nominal 13,800 voltage level. In the event that the Prospective Delivery Point is established, beginning with the date of commercial operation of the Prospective Delivery Point the electric power and energy delivered by Seller to Customer under this Agreement shall be metered for billing purposes at the Prospective Delivery Point, at the nominal 13,800 voltage level.

(e) For the period that the Existing Delivery Point remains in use for purposes of providing electric service to the Rod and Cable Mill: (i) the electric power and energy delivered by Seller to Customer for the Rod and Cable Mill shall be metered for billing purposes at the Southwire Metering Point, which is more particularly defined and described in the Delivery Point Agreement; (ii) for purposes of monthly billings by Seller to Customer, the billing determinants for monthly and hourly energy shall be adjusted based on the actual meter readings at the Southwire Metering Point, plus one percent (1%) to compensate Century for energy losses on the Southwire Interconnection; and (iii) for purposes of monthly billings pursuant to any retail electric service agreements between Seller and Century, the billing determinants for monthly and hourly demand, energy and reactive demand as determined by meter readings at the Existing Delivery Point shall be reduced by subtracting the corresponding billing determinants, as adjusted, for the Rod and Cable Mill.

2.07 Easements and Facilities Provided by Customer. Customer has provided, and shall continue to provide or cause to be provided, without cost to Seller, the following easements and facilities which are or may be necessary for Seller or its power supplier to supply the electric consuming facilities of Customer with retail electric service:

(a) Easements for rights-of-way upon Customer's property, (i) at such locations and of such dimensions as determined by Seller and which are necessary for the construction of facilities which Seller or its power supplier must furnish to provide electric service herein; provided, however, that if Customer wishes to move such facilities in the future,



Seller will cooperate in identifying alternate satisfactory locations so long as any relocation is at Customer's expense; and (ii) an easement for ingress and egress to exercise Seller's rights under this Agreement.

(b) Except as provided in Section 2.08, Customer has furnished, and shall continue to furnish, operate, and maintain (or cause to be furnished, operated, and maintained) such facilities and equipment as may be necessary to enable it to receive and use electric power and energy purchased hereunder at and from the Delivery Point.

2.08 Facilities Provided by Seller. Seller will furnish, or cause to be furnished, at the charges established in this Agreement, all of the facilities required for the delivery of electric power and energy to the Delivery Point specified in this Agreement and in the Delivery Point Agreement, including the following:

(a) No later than 180 days following receipt by Seller and Big Rivers of notice from Customer under Section 2.01(b) of this Agreement to construct distribution and transmission facilities required to establish the Prospective Delivery Point, Seller and Big Rivers will commence design and construction of the transmission facilities and distribution facilities necessary and appropriate for that purpose, including such metering, communications, relaying, control circuits, and associated equipment that is necessary to properly measure, control, and coordinate the delivery of electrical power and energy between Seller's and Customer's facilities.

(b) The cost of the distribution facilities provided by Seller, and the transmission facilities provided by Big Rivers to extend service to Customer at the Prospective Delivery Point shall be paid for by Customer in accordance with Section 3.06.

2.09 Operation and Maintenance of Facilities.

(a) Seller shall construct, operate, and maintain, or cause to be constructed, operated and maintained, all facilities and equipment owned by it or its power supplier and required to supply retail electric service to Customer in accordance with the terms of this Agreement.

(b) Customer shall construct, operate, and maintain, or cause to be constructed, operated, and maintained, all of the facilities and equipment owned by it in accordance with the applicable provisions of the National Electrical Safety Code and all other applicable laws, codes, and regulations; provided, however, that Seller shall have no duty to inspect such facilities for compliance therewith.

2.10 Right of Removal. Any and all equipment, apparatus, devices, or facilities placed or installed, or caused to be placed or installed, by either Party on or in the premises of the other Party shall be and remain the property of the Party owning and installing such equipment, apparatus, devices, or facilities regardless of the mode or manner of annexation or attachment to real property of the other. Upon the termination of this Agreement, the owner thereof shall have the right to enter upon the premises of the other and shall within a reasonable time remove such

equipment, apparatus, devices, or facilities; provided, however, that Customer may not recover any easements or sites conveyed to Seller as referred to in Section 2.07 hereof except to the extent that Seller no longer has a need to make use of such easements or sites.

ARTICLE III  
PAYMENT

3.01 Rates. On and after the Effective Date (as defined in Section 11.02 below) of this Agreement, Customer shall pay Seller for service hereunder at the rates set forth in Seller's Rate Schedule 33, attached hereto as Exhibit B, and other applicable tariffs of Seller, or any successor tariff(s), all of which are incorporated herein by reference, subject to such changes as may become effective from time to time by operation of law or by order of the Commission, provided that in the case of any filing with the Commission which changes or affects the terms, conditions, or rates under this Agreement, Seller gives Customer notice in accordance with the Commission's regulations and orders so that Customer has the opportunity to participate in any proceeding at the Commission affecting the terms, conditions, or rates hereunder.

3.02 Taxes. Customer shall pay all taxes, charges, or assessments now or hereafter applicable to electric service hereunder.

3.03 Billing Demand.

(a) The monthly billing demand shall be the greater of the maximum integrated thirty-minute demand at the Southwire Metering Point (as shall be described in the Delivery Point Agreement, contemplated in Section 1.01 of this Agreement) during each month or the minimum billing demand, with such maximum integrated thirty-minute demand determined by meters which record at the end of each thirty-minute period the integrated kilowatt demand during the preceding thirty minutes. The provisions of Section 2.05 apply to the measured kilowatts.

(b) The minimum billing demand of Customer shall be 60% of the Maximum Contract Demand.

3.04 Payment of Bills. Bills for service furnished during the preceding monthly billing period shall be processed and mailed to Customer, and a copy faxed to Customer, not later than the first Working Day after the thirteenth (13<sup>th</sup>) day of each month. Bills for service hereunder shall be due and payable on or before the first Working Day after the twenty-fourth (24<sup>th</sup>) day of the month. "Working Day" shall mean any day other than a Saturday, Sunday, or banking holiday. In the event payment of the current monthly bill (excluding any amounts as to which there is a bona fide dispute) is not received by Seller on or before the due date, Seller may discontinue delivery of electric power and energy hereunder upon fifteen (15) days notice to Customer of its intention to do so, unless Seller receives payment before the end of such fifteen (15) day notice period. Simple interest equal to the then-effective prime commercial lending rate as published in the "Money Rates" section of *The Wall Street Journal* plus one percent (1%) shall apply to any unpaid amounts from the due date until paid. Any such discontinuance of

service under this paragraph shall not relieve Customer of any of its obligations under this Agreement.

3.05 Customer Deposit. As security for payment of its obligations under this Agreement, Customer shall be required to provide Seller a cash deposit or an irrevocable bank letter of credit representing the sum of (i) two (2) months' estimated billing invoice charges and, (ii) if the notice to proceed with the establishment of the Prospective Delivery Point has been given as provided in Section 2.01(b), the approximate unretired balance of the Distribution Facilities Costs and Transmission Facilities Costs, as defined in Section 3.06. Any cash deposit for estimated billing invoice charges will earn interest in accordance with law, and interest earned will be paid annually to Customer. Letters of credit, including but not limited to the issuer and the terms, must be approved by Seller. Annually, the Parties shall adjust the deposit or bank letter of credit to reflect material changes in the amount of the obligations of Customer to Seller under this Agreement, including but not limited to changes in Customer's load, changes in the rates to Customer, and retirement of portions of Customer's obligation for the Distribution Facilities Costs and Transmission Facilities Costs.

3.06 Distribution Facilities Costs and Transmission Facilities Cost Responsibility. If Seller and Big Rivers commence construction of the distribution and transmission facilities required to establish the Prospective Delivery Point pursuant to notice to proceed from Customer under Section 2.01(b) of this Agreement, Customer's obligation for the costs of those facilities shall be as follows:

(a) Customer accepts responsibility for the actual cost of distribution facilities constructed or caused to be constructed by Seller to extend service to the Prospective Delivery Point, which amount is estimated to be \$228,000.00 (the "Distribution Facilities Costs") as of the Effective Date. This amount shall be payable as a contribution in aid of construction and shall be paid by Customer either in a lump sum prior to commencement of construction of the Distribution Facilities, or by adding an amount as calculated immediately below to each monthly bill from Seller to Customer beginning with the first month in which the actual final amount of the Distribution Facilities Costs is known and Customer has begun to receive service through the Prospective Delivery Point. The monthly amount shall be the amount required each month to fully pay the Distribution Facilities Costs in equal monthly installments during the remainder of the 60-month term of this Agreement, plus interest on the unpaid balance at the rate of six percent (6%) per annum. In addition, Customer shall pay during the term of this Agreement, and any renewals or extensions thereof, a Monthly Facilities Charge to cover overhead and maintenance associated with said distribution facilities by adding an amount equal to 0.66% of the Distribution Facilities Costs to each monthly bill from Seller to Customer beginning contemporaneously with the foregoing monthly bill for recovery of Distribution Facilities Costs. If Customer pays the Distribution Facilities Cost in installments, as security for payment of those costs, Customer shall be required to provide Seller an additional cash deposit or an irrevocable bank letter of credit in an amount equal to the Customer's payment obligation under Section 3.06(b), assuming an immediate termination of this Agreement.

(b) If this Agreement expires or is terminated for any reason, Customer shall pay Seller, in addition to any other obligations which Customer may have for termination or otherwise, an abandonment charge equal to (i) the full amount of the Distribution Facilities Costs, which have been actually incurred and/or are unavoidable as of the date of expiration or termination, reduced by the amount of any Distribution Facilities Costs previously paid by Customer as described above in section 3.06(a), and (ii) the Monthly Facilities Charge for the months remaining in the 60 month term following such expiration or termination.

(c) Customer accepts responsibility for the actual cost of transmission facilities constructed or caused to be constructed by Seller to extend service to the Prospective Delivery Point, which amount is estimated to be \$410,000 (the "Transmission Facilities Costs") on the Effective Date. If this Agreement expires or is terminated for any reason, Customer shall pay Seller, in addition to any other obligations which Customer may have for termination or otherwise, an abandonment charge equal to the full amount of the Transmission Facilities Costs, which have been actually incurred and/or are unavoidable as of the date of expiration or termination, reduced by \$0.90 per kW of demand the Customer has been billed and has paid for under this Agreement. As security for payment of those costs, Customer shall be required to provide Seller an additional cash deposit or an irrevocable bank letter of credit in an amount equal to the Customer's payment obligation under this Section 3.06(c), assuming an immediate termination of this Agreement. The security for payment of those costs shall be due before commencement of construction of the Transmission Facilities.

#### ARTICLE IV CONTINUITY OF SERVICE

4.01 Seller shall use reasonable diligence to provide a constant and uninterrupted supply of electric power and energy hereunder. However, Seller shall not be responsible for damages to Customer occasioned by any failure, shortage, or interruption of service or for failure as a result of Force Majeure (as defined in Section 4.02(c), below).

4.02 In the event either Party shall be unable, wholly or in part, by reason of Force Majeure (as defined below), including Force Majeure preventing Big Rivers from supplying power for Seller's resale to Customer, to carry out its obligations hereunder, on such Party's giving notice and reasonably full particulars of such Force Majeure, first by telephone and then confirmed in writing, to the other Party within a reasonable time after the occurrence of the cause relied upon, then the obligations of the Parties, to the extent they are affected by such Force Majeure, shall be suspended during the continuance of any inability so caused, but for no longer period, and the following provisions shall apply:

(a) Inability of Seller. Should Seller's ability to make power available to Customer in the amount provided for hereunder be interrupted or curtailed for a period longer than 120 consecutive minutes because of Force Majeure, then for the period of and to the extent of such interruption or curtailment, the monthly billing demand shall be prorated by a factor

equal to the ratio of the time Seller is unable to deliver power to the total time in the billing period.

(b) Inability of Customer. If a Force Majeure affects all or a portion of Customer's equipment so that for a period longer than 120 consecutive minutes, Customer is unable to receive and utilize all or a portion of the power that it would have otherwise received and utilized, then an appropriate adjustment will be made in the monthly billing demand, and if the Force Majeure continues for an entire monthly billing period during which the minimum billing demand is greater than the maximum integrated thirty-minute demand for that billing period, the minimum billing demand shall be adjusted downward for purposes of calculating the monthly billing demand for that billing period by the amount of demand reduction attributable to the Force Majeure.

(c) The term "Force Majeure" as used herein, shall mean acts of God, strikes, acts of the public enemy, wars, blockades, insurrections, riots, epidemics, landslides, lightning, earthquakes, fires, storms, floods, washouts, arrests and restraints of government, whether federal, state, or local, civil or military, civil disturbances, explosions, breakage of or accident to machinery, equipment, distribution lines or transmission lines, inability of either Party to obtain necessary materials, supplies, or permits due to existing or future rules, regulations, orders, laws, or proclamations of governmental authorities, whether federal, state, or local, civil or military, and any other causes which are not reasonably within the control of the Party affected.

(d) The Party unable to perform its obligations hereunder by reason of Force Majeure shall remedy such inability with all reasonable dispatch; provided, however, the Customer shall not be required to restore its plant and/or operations to the extent that it is not practical for Customer to do so. The Party affected by an event of Force Majeure shall provide the other with a timely and reasonably full description of the nature and impact of any damages to its facilities and operations caused by such event, and the anticipated duration of the effect thereof on that Party's performance hereunder. Nothing contained herein may be construed to require a Party to prevent or to settle a labor dispute against its will.

## ARTICLE V TERM

5.01 Term and Renewals. This Agreement shall remain in full force and effect for a term beginning with the Effective Date hereof (as defined in Section 11.02 below) and continuing through the 60<sup>th</sup> complete month thereafter. This Agreement shall automatically renew annually thereafter for successive one-year terms upon the same terms and conditions stated herein and in any amendment hereto. This Agreement may be terminated at any time without cause by Customer giving Seller at least six (6) months notice prior to the effective date of such termination.

5.02 Assignment. This Agreement shall be assignable by Customer only if (a) Customer agrees in writing to guarantee all of Customer's obligations hereunder, or (b) Customer obtains the prior written consent of Seller, which consent will not be unreasonably withheld, delayed or conditioned. Seller may withhold approval of a proposed assignment until,

among other things, Seller has been provided with all information it may reasonably require regarding the proposed assignee, including the ability of the proposed assignee to fulfill Customer's obligations hereunder following the proposed assignment.

ARTICLE VI  
RIGHT OF ACCESS

6.01 Duly authorized representatives of Seller shall be permitted to enter upon Customer's premises at all reasonable hours in order to carry out any metering or service provisions of this Agreement, provided, however, that all such representatives abide by Customer's safety rules furnished by Customer to Seller.

6.02 Each Party shall furnish to the other such reports and information concerning its operations as the other may reasonably request from time to time.

ARTICLE VII  
EVENTS OF DEFAULT AND REMEDIES

7.01 Events of Default. Each of the following constitutes an "Event of Default" under this Agreement:

- (a) Failure by Customer to make any payment in accordance with this Agreement;
- (b) Failure of a Party to perform any material duty imposed on it by this Agreement;
- (c) Any attempt by a Party to transfer an interest in this Agreement other than as permitted pursuant to Section 5.02;
- (d) Any filing of a petition in bankruptcy or insolvency, or for reorganization or arrangement under any bankruptcy or insolvency laws, or voluntarily taking advantage of any such laws by answer or otherwise, or the commencement of involuntary proceedings under any such laws by a Party and such petition has not been withdrawn or dismissed within 60 days after filing;
- (e) Assignment by a Party for the benefit of its creditors; or
- (f) Allowance by a Party of the appointment of a receiver or trustee of all or a material part of its property and such receiver or trustee has not been discharged within 60 days after appointment.

7.02 Remedies. Following the occurrence and during the continuance of an Event of Default by either Party, the non-defaulting Party may, in its sole discretion, elect to terminate this Agreement upon written notice to the other Party, or to seek enforcement of its terms at law or in equity. Remedies provided in this Agreement are cumulative. Nothing contained in this

Agreement may be construed to abridge, limit, or deprive either Party of any means of enforcing any remedy either at law or in equity for the breach or default of any of the provisions herein, except as provided in Section 7.03 below.

7.03 LIMITATION OF DAMAGES. UNDER NO CIRCUMSTANCE WILL EITHER PARTY OR ITS RESPECTIVE AFFILIATES, DIRECTORS, OFFICERS, MEMBERS, MANAGERS, EMPLOYEES, OR AGENTS BE LIABLE HEREUNDER TO THE OTHER PARTY, ITS AFFILIATES, DIRECTORS, OFFICERS, MEMBERS, MANAGERS, EMPLOYEES, OR AGENTS, WHETHER IN TORT, CONTRACT, OR OTHERWISE, FOR ANY SPECIAL, INDIRECT, PUNITIVE, EXEMPLARY, OR CONSEQUENTIAL DAMAGES, INCLUDING LOST PROFITS. EACH PARTY'S LIABILITY HEREUNDER WILL BE LIMITED TO DIRECT, ACTUAL DAMAGES. THE EXCLUSION OF ALL OTHER DAMAGES SPECIFIED IN THIS SECTION IS WITHOUT REGARD TO THE CAUSE OR CAUSES RELATING THERETO. THIS PROVISION WILL SURVIVE TERMINATION OF THIS AGREEMENT.

7.04 Survival. Obligations of a Party accrued under this Agreement on the date this Agreement is terminated or otherwise expires shall survive that termination or expiration.

ARTICLE VIII  
NOTICES

8.01 Any notice, demand, or request required or authorized under this Agreement shall be deemed properly given to or served upon the other Party if the notice is in writing and placed in this mail, postage prepaid, or delivered to the other Party at the following addresses:

To the Seller:

Kenergy Corp.  
6402 Old Corydon Road  
P.O. Box 18  
Henderson, KY 42419-0018  
Attn: President and CEO  
Telephone: (270) 826-3991  
Facsimile: (270) 830-6934

To the Customer:

Southwire Company  
One Southwire Drive  
Carrollton, GA 30119  
Attn: \_\_\_\_\_  
Telephone: (770) 832-4242  
Facsimile: \_\_\_\_\_

With a copy to:

Southwire Company  
One Southwire Drive  
Carrollton, GA 30119  
Attn: General Counsel  
Facsimile: (770) 832-5374

Each Party shall have the right to change the name of the person or location to whom or where notice shall be given or served by notifying the other Party in writing of such change.

ARTICLE IX  
REPRESENTATIONS AND WARRANTIES

9.01 Representations of Seller. Seller hereby represents and warrants to Customer as follows:

(a) Seller is an electric cooperative corporation duly organized, validly existing and in good standing under the laws of the Commonwealth of Kentucky, and has the power and authority to execute and deliver this Agreement, to perform its obligations hereunder, and to carry on its business as such business is now being conducted and as is contemplated hereunder to be conducted during the term hereof.

(b) The execution, delivery, and performance of this Agreement by Seller have been duly and effectively authorized by all requisite corporate action.

9.02 Representations and Warranties of Customer. Customer hereby represents and warrants to Seller as follows:

(a) Customer is a corporation duly organized and validly existing and in good standing under the laws of the State of Delaware, is authorized to do business in the Commonwealth of Kentucky, and has the power and authority to execute and deliver this Agreement, to perform its obligations hereunder, and to carry on its business as such business is now being conducted and as is contemplated hereunder to be conducted during the term hereof.

(b) The execution, delivery, and performance of this Agreement by Customer have been duly and effectively authorized by all requisite corporate action.

ARTICLE X  
SEVERABILITY

10.01 The invalidity of any portion of this Agreement shall not affect the validity of the remainder thereof.

ARTICLE XI  
SUCCESSION, APPROVAL, AND EFFECTIVE DATE



11.01 This Agreement shall be binding upon and inure to the benefit of the successors, legal representatives, and permitted assigns of the respective Parties hereto.

11.02 The "Effective Date" of this Agreement shall be the date hereof, except that said Effective Date shall be postponed and this Agreement shall not become effective unless and until this Agreement is approved or accepted in writing by the Commission, the Delivery Point Agreement is executed as contemplated in Section 1.01, and the 2009 Wholesale Power Agreement Amendment is approved or accepted in writing by the Commission and, if required, by the Rural Utilities Service of the U. S. Department of Agriculture, and the 1998 Retail Agreement has been terminated.

## ARTICLE XII MISCELLANEOUS

12.01 Entire Agreement. The terms, covenants, and conditions contained in this Agreement and the Delivery Point Agreement constitute the entire agreement between the Parties and shall supersede all previous communications, representations, or agreements, either oral or written, between the Parties hereto with respect to the subject matter hereof, provided, however, that service to Customer is subject to the lawful orders of the Commission.

12.02 Governing Law, Jurisdiction, and Venue. All respective rights and obligations of the Parties shall be governed by the laws of the Commonwealth of Kentucky and the rules, regulations and orders of the Commission, without regard to its conflicts of law rules. The Parties hereby agree that the courts of the Commonwealth of Kentucky will have exclusive jurisdiction over each and every judicial action brought under or in relationship to this Agreement; provided that the subject matter of such dispute is not a matter reserved by law to the Commission, or to the U.S. federal judicial system (in which event exclusive jurisdiction and venue will lie with the U.S. District Court for the Western District of Kentucky), and the Parties hereby agree to submit to the jurisdiction of Kentucky courts for such purpose. Venue of any state court action, legal or equitable, related to this Agreement shall be Henderson County, Kentucky.

12.03 Waiver. The waiver by either Party of any breach of any term, covenant, or condition contained herein will not be deemed a waiver of any other term, covenant, or condition, nor will it be deemed a waiver of any subsequent breach of the same or any other term, covenant, or condition contained herein.

12.04 Amendments. This Agreement may be amended, revised, or modified by, and only by, a written instrument duly executed by both Parties.

12.05 Counterparts. This Agreement may be executed in any number of counterparts, which together will constitute but one and the same instrument, and each counterpart will have the same force and effect as if they were one original.

12.06 Headings. The headings contained in this Agreement are solely for convenience and do not constitute a part of the agreement between the Parties, nor should such headings be used to aid in any manner in the construction of this Agreement.

IN WITNESS WHEREOF, the Parties hereto have executed this Agreement, as of the day and year first above written.

KENERGY CORP.

By: \_\_\_\_\_  
Sanford Novick  
President and CEO

SOUTHWIRE COMPANY

By: \_\_\_\_\_  
Printed Name: \_\_\_\_\_  
Title: \_\_\_\_\_

**EXHIBIT A**

RECEIVED

JUN 25 2009  
PUBLIC SERVICE  
COMMISSION

**NATIONAL ALUMINUM  
13.8 kV**

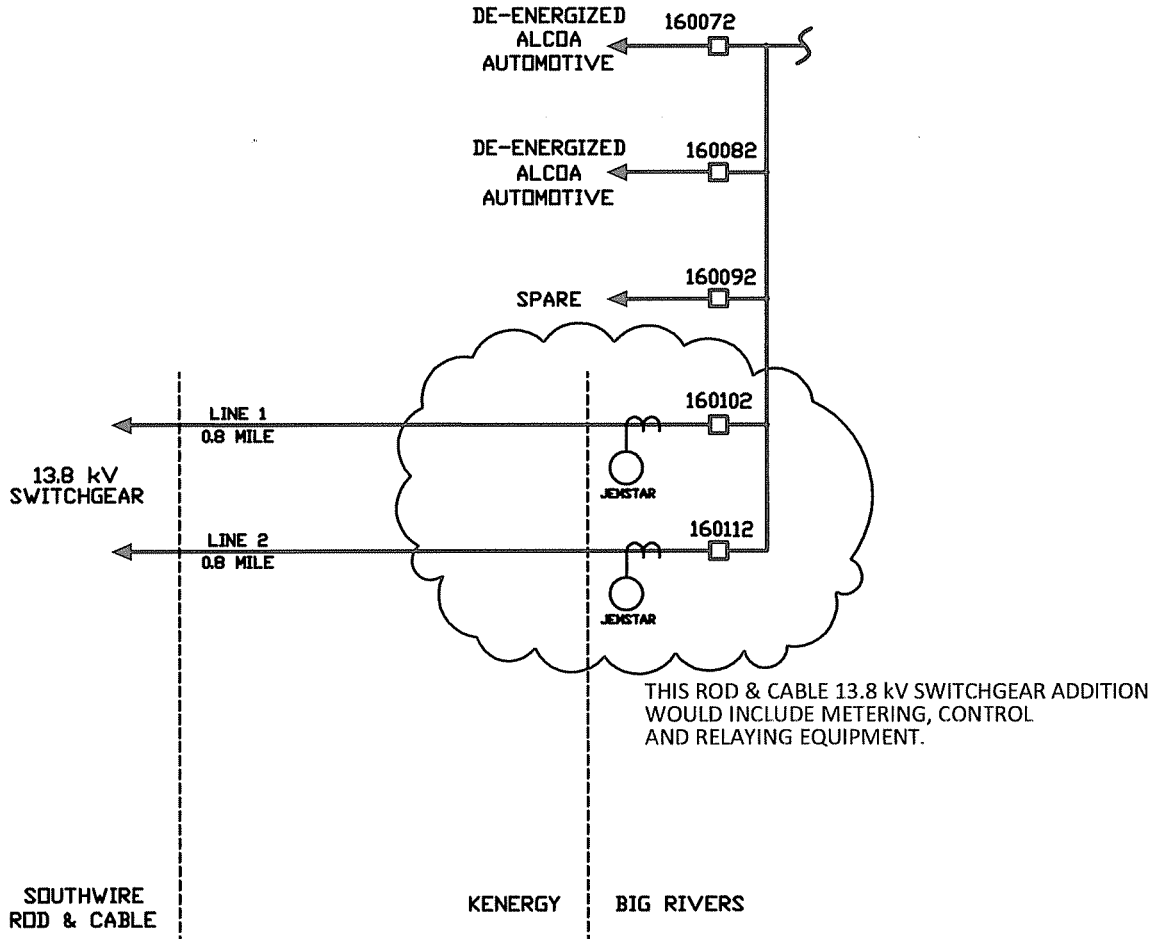

RC-100-1.1

No.	BY	ENG	DATE	REVISION
1	RAK	RMW	6/4/08	ROD & CABLE SWITCHGEAR ADDITION
2	RAK	RMW	3/18/09	ADDED KENERGY LINES



**NATIONAL ALUMINUM  
SWITCHGEAR ADDITION  
PROSPECTIVE DELIVERY POINT**

DWG No.  
**RC-100**

SEQ 1 | SH 1



Henderson, Kentucky

FOR ALL TERRITORY SERVED

Community, Town or City

PSC NO. 2

Original SHEET NO. 33

CANCELLING PSC NO. 1

SHEET NO. \_\_\_\_\_

**CLASSIFICATION OF SERVICE**

Schedule 33 – Large Industrial Customers Served Under Special Contract  
(Dedicated Delivery Points) - (Class C)

**APPLICABLE**

In all territory served.

**AVAILABILITY OF SERVICE**

This rate shall apply to existing large customers where service is provided through a dedicated delivery point connected to the transmission system of Big Rivers or other accessible system classified as Class C customers, or new customers executing special contracts approved by the Kentucky Public Service Commission.

**TYPE OF SERVICE**

The electric service furnished under this schedule will be three-phase sixty cycle, alternating current at available nominal voltage.

**RATE**

Customer Charge per Delivery Point \$100.00 per Month

Plus:  
Demand Charge per KW of Billing Demand in Month \$ 10.15

Plus:  
Energy Charges:  
Per KWH \$0.016715

Facilities Charge 1.30%  
(times assigned dollars of Kenergy investment for facilities per month-see Sheet No.33B)

**DETERMINATION OF BILLING DEMAND**

The Billing Demand in kilowatts shall be the higher of: a) The customer's maximum integrated thirty-minute demand at such delivery point during each billing month, determined by meters which record at the end of each thirty-minute period the integrated kilowatt demand during the preceding thirty minutes; or b) the Contract Demand.

**POWER FACTOR ADJUSTMENT**

The customer agrees to maintain a power factor as nearly as practical to unity. Kenergy will permit the use of apparatus that shall result, during normal operation, in a power factor not lower than 90%. At Kenergy's option, in lieu of the customers providing the above corrective equipment when power factor is less than 90%, Kenergy may adjust the maximum measured demand for billing purposes in accordance with the following formula:

DATE OF ISSUE January 29, 2009

Month / Date / Year

DATE EFFECTIVE February 1, 2009

Month / Date / Year

ISSUED BY Sanford Nouch

(Signature of Officer)

TITLE President and CEO

BY AUTHORITY OF ORDER OF THE PUBLIC SERVICE COMMISSION

IN CASE NO. 2008-00323 DATED January 29, 2009

PUBLIC SERVICE COMMISSION  
OF KENTUCKY  
EFFECTIVE  
2/1/2009  
PURSUANT TO 807 KAR 5:011  
SECTION 9 (1)

By J. D. Brown  
Executive Director



Henderson, Kentucky

FOR ALL TERRITORY SERVED

Community, Town or City

PSC NO. 2

Original SHEET NO. 33A

CANCELLING PSC NO. 1

SHEET NO.

CLASSIFICATION OF SERVICE

Schedule 33 - Large Industrial Customers Served Under Special Contract (Dedicated Delivery Points) - (Class C)

Max. Measured KW x 90% Power Factor (%)

The power factor shall be measured at time of maximum load.

METERING

Electrical usage will be metered at the transmission voltage supplied or at the customer's secondary voltage with a 1.0% adder to the metered KWH to account for transformer losses, as determined by Kenergy.

ADJUSTMENT CLAUSES

The bill amount computed at the charges specified above shall be increased or decreased in accordance with the following:

Renewable Resource Energy Service Rider Sheets No. 23 - 23D
Price Curtailable Service Rider Sheets No. 42 - 42C

AGREEMENT

An "agreement for purchase of power" shall be signed by any new customer prior to service under the rate. Should the provisions of the expansion rate contained on Sheets No. 41-41G apply, additional language incorporating those provisions will be added to the agreement.

TAXES AND FEES

School Taxes added if applicable.
Kentucky Sales Taxes added if applicable.

FRANCHISE CHARGE

The rate herein provided shall include, where applicable, an additional charge for local government franchise payment determined in accordance with the Franchise Billing Plan as set forth on Sheet No. 105.

TERMS OF PAYMENT

The above rates are net, the gross rate being five percent (5%) greater. In the event the current monthly bill is not paid within twenty (20) days from the date the bill was rendered, the gross rate will apply.

DATE OF ISSUE January 29, 2009

Month / Date / Year

DATE EFFECTIVE February 1, 2009

Month / Date / Year

ISSUED BY Sanford Nouch

(Signature of Officer)

TITLE President and CEO

BY AUTHORITY OF ORDER OF THE PUBLIC SERVICE COMMISSION

IN CASE NO. 2008-00323 DATED January 29, 2009

PUBLIC SERVICE COMMISSION OF KENTUCKY EFFECTIVE 2/1/2009 PURSUANT TO 807 KAR 5:011 SECTION 9 (1)

By [Signature] Executive Director



Henderson, Kentucky

FOR ALL TERRITORY SERVED

Community, Town or City

PSC NO. 2

Original SHEET NO. 33B

CANCELLING PSC NO. 1

SHEET NO.

CLASSIFICATION OF SERVICE

Schedule 33 - Large Industrial Customers Served Under Special Contract (Dedicated Delivery Points) - (Class C)

DETERMINATION OF FACILITIES CHARGE RATE

Table with columns: Line No., Item, Total. Rows include Distribution O&M Expense, Distribution Plant @ Year End, Dist. Exp. Cost Factor, Test Year A&G Acct. Expense, Test Year O&M Expense Excluding A&G, Line 5/Line 6, Dist. Expense Carrying Cost Factor, A&G Cost Factor, Distribution Plant Depreciation Rate, Cost of Capital, Amortization Factor, General Plant Factor, General Plant @ Year End, General Plant Depreciation Rate, Not Used, Amortization Factor, General Plant Fixed Charge Rate, General Plant Fixed Charges, Total Utility Plant, Percent of TUP - General Plant Factor, SUMMARY: O&M Factor, A&G Factor, Depreciation Expense, Levelized Rate of Return, General Plant Factor, Total Annual Carrying Cost, PSC Assessment, Adjustment Annual Carrying Cost, Monthly Facilities Rate Charge.

PUBLIC SERVICE COMMISSION OF KENTUCKY EFFECTIVE 2/1/2009 PURSUANT TO 807 KAR 5:011 SECTION 9 (1)

By [Signature] Executive Director

DATE OF ISSUE January 29, 2009 Month / Date / Year

DATE EFFECTIVE February 1, 2009 Month / Date / Year

ISSUED BY [Signature] (Signature of Officer)

TITLE President and CEO

BY AUTHORITY OF ORDER OF THE PUBLIC SERVICE COMMISSION IN CASE NO. 2008-00323 DATED January 29, 2009

AGREEMENT FOR RETAIL ELECTRIC SERVICE

THIS AGREEMENT FOR ELECTRIC SERVICE ("Agreement"), is made and entered into as of the \_\_\_\_ day of July, 2009, by and between KENERGY CORP., a Kentucky electric cooperative corporation, with its principal office located at 6402 Old Corydon Road, P.O. Box 18, Henderson, Kentucky 42419-0018 (hereinafter, the "Seller"), and SOUTHWIRE COMPANY, a Delaware corporation, with its principal office located at One Southwire Drive, Carrollton, GA 30119 (hereinafter, the "Customer") (Seller and Customer are individually referred to herein as a "Party" and collectively as the "Parties").

Deleted: May

WHEREAS, Customer and Green River Electric Corporation ("GREC"), Seller's predecessor in interest, entered into an Agreement for Electric Service dated July 15, 1998, (as amended, the "1998 Retail Agreement"), and related agreements, under which GREC agreed to supply electric service to Customer for use at Customer's primary aluminum smelter ("Smelter") and Customer's adjacent rod and cable mill ("Rod and Cable Mill"), both located in Hancock County, Kentucky;

WHEREAS, effective as of April 1, 2001, pursuant to a certain Stock Purchase Agreement dated August 31, 2000, between Century Aluminum Company ("Century") and Customer, Century acquired all of the issued and outstanding capital stock of certain subsidiaries of Customer that together owned all of the partnership interests of NSA, L.P., an indirect wholly owned subsidiary of Customer that, in turn, owned and operated the Smelter. Under a Master Assignment Agreement between Customer and Century dated November 22, 2000, as amended, Customer partially assigned its rights and interests under the 1998 Retail Agreement and related agreements to Century, except that Customer retained such rights and interests as necessary for it to continue to acquire electric service for use at its Rod and Cable Mill, with Century acting as Customer's agent for the limited purpose of facilitating Customer's acquisition of electric service for the Rod and Cable Mill;

WHEREAS, Seller and Big Rivers Electric Corporation ("Big Rivers"), Seller's wholesale power supplier, have amended the wholesale power agreements between them (the "2009 Wholesale Power Agreement Amendment") to establish the terms on which Big Rivers will supply electric service to Seller for Seller to resell to Customer under this Agreement for use at Customer's Rod and Cable Mill; and

WHEREAS, the Parties wish to enter into this new Agreement under which Seller will provide the exclusive source of electric service to Customer for use at the Customer's Rod and Cable Mill, which new Agreement replaces and supersedes any and all other agreements between the Parties, or between a Party and any third party for retail electric service to Customer;

NOW, THEREFORE, in consideration of the mutual covenants contained herein, the Parties agree as follows:

Formatted: Left

RECEIVED

JUN 25 2009

PUBLIC SERVICE  
COMMISSION

ARTICLE I  
GENERAL OBLIGATIONS

1.01 Basic Obligations of the Parties. Seller will supply, sell, and deliver to Customer, and Customer will accept and pay for, all of the electric power and energy required by Customer for the operation of its Rod and Cable Mill, up to the Maximum Contract Demand (as defined in Section 2.03 below). This service will be supplied under this Agreement, and the rules, regulations, and orders of the Public Service Commission of Kentucky ("Commission"), which may be applicable and effective from time to time. Seller and Customer agree that this Agreement and the Delivery Point Agreement (the "Delivery Point Agreement," that will be entered into as contemplated in this Section 1.01) contain the exclusive terms and conditions on which Seller will provide retail electric service to Customer during the term of this Agreement. The obligation of Seller to commence delivery of electric power and energy under this Agreement is contingent upon, and shall be postponed until Seller, Big Rivers, Customer and Century have executed a Delivery Point Agreement that provides for delivery of power and energy hereunder at the Existing Delivery Point (as defined in Section 2.01(a)) in form and substance acceptable to each of those parties.

Deleted: 04

1.02 Membership. Customer has been and shall continue to be a member of Seller, and shall be bound by such rules and regulations as may be adopted from time to time by Seller consistent with the terms and conditions of this Agreement.

ARTICLE II  
SERVICE CHARACTERISTICS

2.01 Delivery Point. The "Delivery Point" of the electric power and energy made available under this Agreement shall be the point at which Customer's facilities connect to Seller's facilities, or facilities designated by Customer, and is more specifically defined below as either the "Existing Delivery Point" or the "Prospective Delivery Point."

(a) The Delivery Point on the Effective Date of this Agreement, as defined in Section 11.02, shall be the "Existing Delivery Point," as defined and described in Section 2.01(c), below. The electric power and energy delivered to the Existing Delivery Point will be in the form of three-phase alternating current (60 hertz) at the nominal 161,000 voltage level.

Deleted: volts

(b) Upon notice from Customer, Seller and Big Rivers agree to proceed with all reasonable dispatch with the construction of distribution and transmission facilities required to establish a new and separate dedicated point of delivery from Kenergy to the Rod and Cable Mill (the "Prospective Delivery Point"), as further described in Exhibit A, attached hereto, that does not utilize either the Existing Delivery Point or the Southwire Interconnection (as defined and described in Section 2.01(c), below). Customer shall be responsible for the costs of construction of those distribution and transmission facilities as provided in Section 3.06 of this Agreement. Beginning with the date of commercial operation of the Prospective Delivery Point, the Prospective Delivery Point shall become the Delivery Point under this Agreement. The electric power and energy delivered to the Prospective Delivery Point will be in the form of three-phase alternating current (60 hertz) at the nominal 13,800 voltage level.



(c) For purposes of this Agreement the terms (i) "Existing Delivery Point" shall mean the existing set of meters at Big Rivers' Coleman substation through which both the Smelter and the Rod and Cable Mill accept electric service; and (ii) "Southwire Interconnection" shall mean the physical assets owned by Century through which electric power and energy is both transformed and delivered from the Existing Delivery Point to the existing set of meters at which the Rod and Cable Mill currently accepts electric service at the 13,800 voltage level.

Deleted: kilovolts

2.02 Service Restriction. Customer shall not use the electric power and energy furnished hereunder as an auxiliary or supplement to any other source of purchased power and shall not sell any electric power and energy purchased hereunder.

2.03 Maximum Contract Demand.

(a) The initial maximum demand of Customer during the term of this Agreement, or any extension thereof, shall be 6,800 kilowatts (the "Maximum Contract Demand"), unless increased or decreased as permitted under Section 2.03(b), or otherwise agreed in writing by the Parties. Seller shall not be obligated to supply capacity in excess of said demand, measured as specified in Section 3.03(a) of this Agreement; provided, however that if Customer modifies or expands its plant in such a way as to increase its electric requirements, Customer shall be entitled to obtain additional service, so long as the increase is in compliance with Seller's rules and regulations filed with and approved by the Commission.

(b) The Maximum Contract Demand may be unilaterally increased or decreased by Customer, from time to time, up to a maximum of 10,000 kW or to a minimum of 3,000 kW by giving written notice to Seller at least 60 days prior to the effective date of the increase or decrease. For purposes of Seller's Rate Schedule 41 and Big Rivers' Rate Schedule 10, the parties agree that 4,575 kW is Customer's Base Year peak demand. The effective date of any unilateral increase or decrease by Customer in its Maximum Contract Demand shall be the first day of a calendar month.

(c) The Maximum Contract Demand shall be measured as the highest integrated kilowatt demand occurring during a thirty-minute period at the beginning and mid-point of a clock hour in the billing month, as measured by the coincidental sum of Customer's meters.

2.04 System Disturbances; Obligation For Damages.

(a) A "System Disturbance" shall be deemed to exist if the use of power by Customer directly or indirectly results in a risk of harm to human beings or material damage to or substantial interference with the functioning of Big Rivers' generating system or transmission system, Seller's distribution system, or the plant, facility, equipment or operations of any customer of one of Big Rivers' distribution cooperatives. A System Disturbance includes, but is not limited to: (i) a level of current harmonic total demand distortion ("TDD") measured at the Delivery Point that exceeds the limits on TDD described in IEEE Standard 519, Section 10; and

(ii) a use of capacity and energy in such a manner that causes a current imbalance between phases greater than five percent (5%) at the Delivery Point.

(b) In its role as control area operator and reader of the meters serving Seller, Big Rivers shall have primary responsibility for determining the existence and source of System Disturbances. If Big Rivers reasonably believes that Customer is responsible for a System Disturbance, it shall provide notice to Seller and Customer, and Customer may take, but shall not be obligated to take, appropriate action at its sole expense to cure, correct or suppress such System Disturbance. If the Customer declines for any reason to take action to correct the System Disturbance, then Seller shall undertake, or cause Big Rivers to undertake, appropriate action to cure, correct or suppress such System Disturbance. Customer shall be obligated to reimburse Seller for all costs incurred by Seller or Big Rivers to cure, correct or suppress such System Disturbance, provided that such action was successful in curing, correcting or suppressing such System Disturbance, and further providing that Customer is conclusively determined to be the cause of such System Disturbance.

(c) Customer acknowledges and agrees that Seller shall have no responsibility for damage to any property, or to any equipment or devices connected to Customer's electrical system on Customer's side of the Delivery Point that results solely from acts or omissions of Customer, its employees, agents, contractors or invitees, or malfunction of any equipment or devices connected to Customer's electrical system on Customer's side of the Delivery Point.

#### 2.05 Power Factor

(a) Pursuant to the 1998 Retail Agreement, with respect to the Rod and Cable Mill, Customer made certain payments to Seller and Big Rivers as compensation for an entitlement to 4,000 kilovars for the purpose of financially mitigating the reactive demand at the Rod and Cable Mill in excess of the reactive demand, measured in kilovars, to which Customer otherwise would be entitled without further compensation based on the Customer's maximum monthly demand and a power factor of ninety percent (90%). As a continuation of such entitlement, the Parties acknowledge that under this Agreement, Customer shall receive up to 4,000 kilovars per month without further compensation from Customer to Seller. For purposes of Section 2.05(b) below, each calculation of Customer's power factor, including the power factor for purposes of the formula set forth at the end of Section 2.05(b), shall reflect the Customer's monthly maximum metered kilovar demand, less 4,000 kilovars.

(b) Subject to Customer's entitlement to 4,000 kilovars per month as set forth in Section 2.05(a) of this Agreement, Customer shall maintain a power factor at the Delivery Point as nearly as practicable to unity. Power factor during normal operation may range from unity to ninety percent (90%). If Customer's power factor is less than 90% at time of maximum load, after adjusting for Customer's entitlement to 4,000 kilovars, Seller reserves the right to require Customer to choose either (a) installation at Customer's expense of equipment which will maintain a power factor of 90% or higher; or (b) adjustment of the maximum monthly metered demand for billing purposes in accordance with the following formula:

Maximum Actual Measured Kilowatts x 90%

**Deleted:** (d) Seller acknowledges and agrees that it shall have no responsibility for damage to any property, or to any equipment or devices connected to Customer's electrical system on Customer's side of the Delivery Point, except those that result solely from negligent acts or omissions or intentional acts of Seller, or Seller's employees, contractors or invitees acting within the scope of their employment, contract or invitation, respectively.¶

Formatted: Left

2.06 Metering.

(a) The metering equipment necessary to register the electric demand and energy for this service shall be furnished, installed, operated, and maintained by Seller or Big Rivers on behalf of Seller, and shall be and remain the property of Seller or Big Rivers.

(b) Each meter shall be read on or about the first day of each month, or such other day as may be mutually agreed upon by a representative of Seller and Customer, and may be simultaneously read by a representative of Customer should Customer so elect. Customer agrees that during the period that the Delivery Point is the Existing Delivery Point, meter readings shall, for billing purposes, be grossed up as stated in Section 2.06(e), below.

(c) All inspections and testing of metering equipment shall be performed in accordance with applicable rules and regulations of the Commission.

(d) The metering point shall be at the Southwire Metering Point, as described in Section 2.06(e), below, at the nominal 13,800 voltage level. In the event that the Prospective Delivery Point is established, beginning with the date of commercial operation of the Prospective Delivery Point the electric power and energy delivered by Seller to Customer under this Agreement shall be metered for billing purposes at the Prospective Delivery Point, at the nominal 13,800 voltage level.

Deleted: Delivery

(e) For the period that the Existing Delivery Point remains in use for purposes of providing electric service to the Rod and Cable Mill: (i) the electric power and energy delivered by Seller to Customer for the Rod and Cable Mill shall be metered for billing purposes at the Southwire Metering Point, which is more particularly defined and described in the Delivery Point Agreement; (ii) for purposes of monthly billings by Seller to Customer, the billing determinants for monthly and hourly energy shall be adjusted based on the actual meter readings at the Southwire Metering Point, plus one percent (1%) to compensate Century for energy losses on the Southwire Interconnection; and (iii) for purposes of monthly billings pursuant to any retail electric service agreements between Seller and Century, the billing determinants for monthly and hourly demand, energy and reactive demand as determined by meter readings at the Existing Delivery Point shall be reduced by subtracting the corresponding billing determinants, as adjusted, for the Rod and Cable Mill.

Deleted: Delivery

Deleted: Delivery

2.07 Easements and Facilities Provided by Customer. Customer has provided, and shall continue to provide or cause to be provided, without cost to Seller, the following easements and facilities which are or may be necessary for Seller or its power supplier to supply the electric consuming facilities of Customer with retail electric service:

(a) Easements for rights-of-way upon Customer's property, (i) at such locations and of such dimensions as determined by Seller and which are necessary for the construction of facilities which Seller or its power supplier must furnish to provide electric service herein; provided, however, that if Customer wishes to move such facilities in the future,

Seller will cooperate in identifying alternate satisfactory locations so long as any relocation is at Customer's expense; and (ii) an easement for ingress and egress to exercise Seller's rights under this Agreement.

(b) Except as provided in Section 2.08, Customer has furnished, and shall continue to furnish, operate, and maintain (or cause to be furnished, operated, and maintained) such facilities and equipment as may be necessary to enable it to receive and use electric power and energy purchased hereunder at and from the Delivery Point.

2.08 Facilities Provided by Seller. Seller will furnish, or cause to be furnished, at the charges established in this Agreement, all of the facilities required for the delivery of electric power and energy to the Delivery Point specified in this Agreement and in the Delivery Point Agreement, including the following:

(a) No later than 180 days following receipt by Seller and Big Rivers of notice from Customer under Section 2.01(b) of this Agreement to construct distribution and transmission facilities required to establish the Prospective Delivery Point, Seller and Big Rivers will commence design and construction of the transmission facilities and distribution facilities necessary and appropriate for that purpose, including such metering, communications, relaying, control circuits, and associated equipment that is necessary to properly measure, control, and coordinate the delivery of electrical power and energy between Seller's and Customer's facilities.

(b) The cost of the distribution facilities provided by Seller, and the transmission facilities provided by Big Rivers to extend service to Customer at the Prospective Delivery Point shall be paid for by Customer in accordance with Section 3.06.

2.09 Operation and Maintenance of Facilities.

(a) Seller shall construct, operate, and maintain, or cause to be constructed, operated and maintained, all facilities and equipment owned by it or its power supplier and required to supply retail electric service to Customer in accordance with the terms of this Agreement.

(b) Customer shall construct, operate, and maintain, or cause to be constructed, operated, and maintained, all of the facilities and equipment owned by it in accordance with the applicable provisions of the National Electrical Safety Code and all other applicable laws, codes, and regulations; provided, however, that Seller shall have no duty to inspect such facilities for compliance therewith.

2.10 Right of Removal. Any and all equipment, apparatus, devices, or facilities placed or installed, or caused to be placed or installed, by either Party on or in the premises of the other Party shall be and remain the property of the Party owning and installing such equipment, apparatus, devices, or facilities regardless of the mode or manner of annexation or attachment to real property of the other. Upon the termination of this Agreement, the owner thereof shall have the right to enter upon the premises of the other and shall within a reasonable time remove such

equipment, apparatus, devices, or facilities; provided, however, that Customer may not recover any easements or sites conveyed to Seller as referred to in Section 2.07 hereof except to the extent that Seller no longer has a need to make use of such easements or sites.

ARTICLE III  
PAYMENT

3.01 Rates. On and after the Effective Date (as defined in Section 11.02 below) of this Agreement, Customer shall pay Seller for service hereunder at the rates set forth in Seller's Rate Schedule 33, attached hereto as Exhibit B, and other applicable tariffs of Seller, or any successor tariff(s), all of which are incorporated herein by reference, subject to such changes as may become effective from time to time by operation of law or by order of the Commission, provided that in the case of any filing with the Commission which changes or affects the terms, conditions, or rates under this Agreement, Seller gives Customer notice in accordance with the Commission's regulations and orders so that Customer has the opportunity to participate in any proceeding at the Commission affecting the terms, conditions, or rates hereunder.

Deleted: C

3.02 Taxes. Customer shall pay all taxes, charges, or assessments now or hereafter applicable to electric service hereunder.

3.03 Billing Demand.

(a) The monthly billing demand shall be the greater of the maximum integrated thirty-minute demand at the Southwire Metering Point (as shall be described in the Delivery Point Agreement, contemplated in Section 1.01 of this Agreement) during each month or the minimum billing demand, with such maximum integrated thirty-minute demand determined by meters which record at the end of each thirty-minute period the integrated kilowatt demand during the preceding thirty minutes. The provisions of Section 2.05 apply to the measured kilowatts.

Deleted: Delivery

Deleted: Section 3 of

(b) The minimum billing demand of Customer shall be 60% of the Maximum Contract Demand.

Deleted: the greater of 3,000 kilowatts, or

3.04 Payment of Bills. Bills for service furnished during the preceding monthly billing period shall be processed and mailed to Customer, and a copy faxed to Customer, not later than the first Working Day after the thirteenth (13<sup>th</sup>) day of each month. Bills for service hereunder shall be due and payable on or before the first Working Day after the twenty-fourth (24<sup>th</sup>) day of the month. "Working Day" shall mean any day other than a Saturday, Sunday, or banking holiday. In the event payment of the current monthly bill (excluding any amounts as to which there is a bona fide dispute) is not received by Seller on or before the due date, Seller may discontinue delivery of electric power and energy hereunder upon fifteen (15) days notice to Customer of its intention to do so, unless Seller receives payment before the end of such fifteen (15) day notice period. Simple interest equal to the then-effective prime commercial lending rate as published in the "Money Rates" section of *The Wall Street Journal* plus one percent (1%) shall apply to any unpaid amounts from the due date until paid. Any such discontinuance of

service under this paragraph shall not relieve Customer of any of its obligations under this Agreement.

3.05 Customer Deposit. As security for payment of its obligations under this Agreement, Customer shall be required to provide Seller a cash deposit or an irrevocable bank letter of credit representing the sum of (i) two (2) months' estimated billing invoice charges and, (ii) if the notice to proceed with the establishment of the Prospective Delivery Point has been given as provided in Section 2.01(b), the approximate unretired balance of the Distribution Facilities Costs and Transmission Facilities Costs, as defined in Section 3.06. Any cash deposit for estimated billing invoice charges will earn interest in accordance with law, and interest earned will be paid annually to Customer. Letters of credit, including but not limited to the issuer and the terms, must be approved by Seller. Annually, the Parties shall adjust the deposit or bank letter of credit to reflect material changes in the amount of the obligations of Customer to Seller under this Agreement, including but not limited to changes in Customer's load, changes in the rates to Customer, and retirement of portions of Customer's obligation for the Distribution Facilities Costs and Transmission Facilities Costs.

3.06 Distribution Facilities Costs and Transmission Facilities Cost Responsibility. If Seller and Big Rivers commence construction of the distribution and transmission facilities required to establish the Prospective Delivery Point pursuant to notice to proceed from Customer under Section 2.01(b) of this Agreement, Customer's obligation for the costs of those facilities shall be as follows:

(a) Customer accepts responsibility for the actual cost of distribution facilities constructed or caused to be constructed by Seller to extend service to the Prospective Delivery Point, which amount is estimated to be \$228,000.00 (the "Distribution Facilities Costs") as of the Effective Date. This amount shall be payable as a contribution in aid of construction and shall be paid by Customer either in a lump sum prior to commencement of construction of the Distribution Facilities, or by adding an amount as calculated immediately below to each monthly bill from Seller to Customer beginning with the first month in which the actual final amount of the Distribution Facilities Costs is known and Customer has begun to receive service through the Prospective Delivery Point. The monthly amount shall be the amount required each month to fully pay the Distribution Facilities Costs in equal monthly installments during the remainder of the 60-month term of this Agreement, plus interest on the unpaid balance at the rate of six percent (6%) per annum. In addition, Customer shall pay during the term of this Agreement, and any renewals or extensions thereof, a Monthly Facilities Charge to cover overhead and maintenance associated with said distribution facilities by adding an amount equal to 0.66% of the Distribution Facilities Costs to each monthly bill from Seller to Customer beginning contemporaneously with the foregoing monthly bill for recovery of Distribution Facilities Costs. If Customer pays the Distribution Facilities Cost in installments, as security for payment of those costs, Customer shall be required to provide Seller an additional cash deposit or an irrevocable bank letter of credit in an amount equal to the Customer's payment obligation under Section 3.06(b), assuming an immediate termination of this Agreement.

Formatted: Left

Deleted: Permanent

Deleted: remaining

Deleted: including any renewals or extensions thereof,

(b) If this Agreement expires or is terminated for any reason, Customer shall pay Seller, in addition to any other obligations which Customer may have for termination or otherwise, an abandonment charge equal to (i) the full amount of the Distribution Facilities Costs, which have been actually incurred and/or are unavoidable as of the date of expiration or termination, reduced by the amount of any Distribution Facilities Costs previously paid by Customer as described above in section 3.06(a), and (ii) the Monthly Facilities Charge for the months remaining in the 60 month term following such expiration or termination.

(c) Customer accepts responsibility for the actual cost of transmission facilities constructed or caused to be constructed by Seller to extend service to the Prospective Delivery Point, which amount is estimated to be \$410,000 (the "Transmission Facilities Costs") on the Effective Date. If this Agreement expires or is terminated for any reason, Customer shall pay Seller, in addition to any other obligations which Customer may have for termination or otherwise, an abandonment charge equal to the full amount of the Transmission Facilities Costs, which have been actually incurred and/or are unavoidable as of the date of expiration or termination, reduced by \$0.90 per kW of demand the Customer has been billed and has paid for under this Agreement. As security for payment of those costs, Customer shall be required to provide Seller an additional cash deposit or an irrevocable bank letter of credit in an amount equal to the Customer's payment obligation under this Section 3.06(c), assuming an immediate termination of this Agreement. The security for payment of those costs shall be due before commencement of construction of the Transmission Facilities.

#### ARTICLE IV CONTINUITY OF SERVICE

4.01 Seller shall use reasonable diligence to provide a constant and uninterrupted supply of electric power and energy hereunder. However, Seller shall not be responsible for damages to Customer occasioned by any failure, shortage, or interruption of service or for failure as a result of Force Majeure (as defined in Section 4.02(c), below).

4.02 In the event either Party shall be unable, wholly or in part, by reason of Force Majeure (as defined below), including Force Majeure preventing Big Rivers from supplying power for Seller's resale to Customer, to carry out its obligations hereunder, on such Party's giving notice and reasonably full particulars of such Force Majeure, first by telephone and then confirmed in writing, to the other Party within a reasonable time after the occurrence of the cause relied upon, then the obligations of the Parties, to the extent they are affected by such Force Majeure, shall be suspended during the continuance of any inability so caused, but for no longer period, and the following provisions shall apply:

(a) Inability of Seller. Should Seller's ability to make power available to Customer in the amount provided for hereunder be interrupted or curtailed for a period longer than 120 consecutive minutes because of Force Majeure, then for the period of and to the extent of such interruption or curtailment, the monthly billing demand shall be prorated by a factor

equal to the ratio of the time Seller is unable to deliver power to the total time in the billing period.

(b) Inability of Customer. If a Force Majeure affects all or a portion of Customer's equipment so that for a period longer than 120 consecutive minutes, Customer is unable to receive and utilize all or a portion of the power that it would have otherwise received and utilized, then an appropriate adjustment will be made in the monthly billing demand, and if the Force Majeure continues for an entire monthly billing period during which the minimum billing demand is greater than the maximum integrated thirty-minute demand for that billing period, the minimum billing demand shall be adjusted downward for purposes of calculating the monthly billing demand for that billing period by the amount of demand reduction attributable to the Force Majeure.

(c) The term "Force Majeure" as used herein, shall mean acts of God, strikes, acts of the public enemy, wars, blockades, insurrections, riots, epidemics, landslides, lightning, earthquakes, fires, storms, floods, washouts, arrests and restraints of government, whether federal, state, or local, civil or military, civil disturbances, explosions, breakage of or accident to machinery, equipment, distribution lines or transmission lines, inability of either Party to obtain necessary materials, supplies, or permits due to existing or future rules, regulations, orders, laws, or proclamations of governmental authorities, whether federal, state, or local, civil or military, and any other causes which are not reasonably within the control of the Party affected.

(d) The Party unable to perform its obligations hereunder by reason of Force Majeure shall remedy such inability with all reasonable dispatch; provided, however, the Customer shall not be required to restore its plant and/or operations to the extent that its is not practical for Customer to do so. The Party affected by an event of Force Majeure shall provide the other with a timely and reasonably full description of the nature and impact of any damages to its facilities and operations caused by such event, and the anticipated duration of the effect thereof on that Party's performance hereunder. Nothing contained herein may be construed to require a Party to prevent or to settle a labor dispute against its will.

ARTICLE V  
TERM

5.01 Term and Renewals. This Agreement shall remain in full force and effect for a term beginning with the Effective Date hereof (as defined in Section 11.02 below) and continuing through the 60<sup>th</sup> complete month thereafter. This Agreement shall automatically renew annually thereafter for successive one-year terms upon the same terms and conditions stated herein and in any amendment hereto. This Agreement may be terminated at any time without cause by Customer giving Seller at least six (6) months notice prior to the effective date of such termination.

5.02 Assignment. This Agreement shall be assignable by Customer only if (a) Customer agrees in writing to guarantee all of Customer's obligations hereunder, or (b) Customer obtains the prior written consent of Seller, which consent will not be unreasonably withheld, delayed or conditioned. Seller may withhold approval of a proposed assignment until,

Formatted: Left

Deleted: the other



among other things, Seller has been provided with all information it may reasonably require regarding the proposed assignee, including the ability of the proposed assignee to fulfill Customer's obligations hereunder following the proposed assignment.

ARTICLE VI  
RIGHT OF ACCESS

6.01 Duly authorized representatives of Seller shall be permitted to enter upon Customer's premises at all reasonable hours in order to carry out any metering or service provisions of this Agreement, provided, however, that all such representatives abide by Customer's safety rules furnished by Customer to Seller.

6.02 Each Party shall furnish to the other such reports and information concerning its operations as the other may reasonably request from time to time.

ARTICLE VII  
EVENTS OF DEFAULT AND REMEDIES

7.01 Events of Default. Each of the following constitutes an "Event of Default" under this Agreement:

- (a) Failure by Customer to make any payment in accordance with this Agreement;
- (b) Failure of a Party to perform any material duty imposed on it by this Agreement;
- (c) Any attempt by a Party to transfer an interest in this Agreement other than as permitted pursuant to Section 5.02;
- (d) Any filing of a petition in bankruptcy or insolvency, or for reorganization or arrangement under any bankruptcy or insolvency laws, or voluntarily taking advantage of any such laws by answer or otherwise, or the commencement of involuntary proceedings under any such laws by a Party and such petition has not been withdrawn or dismissed within 60 days after filing;
- (e) Assignment by a Party for the benefit of its creditors; or
- (f) Allowance by a Party of the appointment of a receiver or trustee of all or a material part of its property and such receiver or trustee has not been discharged within 60 days after appointment.

7.02 Remedies. Following the occurrence and during the continuance of an Event of Default by either Party, the non-defaulting Party may, in its sole discretion, elect to terminate this Agreement upon written notice to the other Party, or to seek enforcement of its terms at law or in equity. Remedies provided in this Agreement are cumulative. Nothing contained in this

Agreement may be construed to abridge, limit, or deprive either Party of any means of enforcing any remedy either at law or in equity for the breach or default of any of the provisions herein, except as provided in Section 7.03 below.

7.03 LIMITATION OF DAMAGES. UNDER NO CIRCUMSTANCE WILL EITHER PARTY OR ITS RESPECTIVE AFFILIATES, DIRECTORS, OFFICERS, MEMBERS, MANAGERS, EMPLOYEES, OR AGENTS BE LIABLE HEREUNDER TO THE OTHER PARTY, ITS AFFILIATES, DIRECTORS, OFFICERS, MEMBERS, MANAGERS, EMPLOYEES, OR AGENTS, WHETHER IN TORT, CONTRACT, OR OTHERWISE, FOR ANY SPECIAL, INDIRECT, PUNITIVE, EXEMPLARY, OR CONSEQUENTIAL DAMAGES, INCLUDING LOST PROFITS. EACH PARTY'S LIABILITY HEREUNDER WILL BE LIMITED TO DIRECT, ACTUAL DAMAGES. THE EXCLUSION OF ALL OTHER DAMAGES SPECIFIED IN THIS SECTION IS WITHOUT REGARD TO THE CAUSE OR CAUSES RELATING THERETO. THIS PROVISION WILL SURVIVE TERMINATION OF THIS AGREEMENT.

7.04 Survival. Obligations of a Party accrued under this Agreement on the date this Agreement is terminated or otherwise expires shall survive that termination or expiration.

ARTICLE VIII  
NOTICES

8.01 Any notice, demand, or request required or authorized under this Agreement shall be deemed properly given to or served upon the other Party if the notice is in writing and placed in this mail, postage prepaid, or delivered to the other Party at the following addresses:

To the Seller:

Kenergy Corp.  
6402 Old Corydon Road  
P.O. Box 18  
Henderson, KY 42419-0018  
Attn: President and CEO  
Telephone: (270) 826-3991  
Facsimile: (270) 830-6934

To the Customer:

Southwire Company  
One Southwire Drive  
Carrollton, GA 30119  
Attn: \_\_\_\_\_  
Telephone: (770) 832-4242  
Facsimile: \_\_\_\_\_

With a copy to:

Southwire Company  
One Southwire Drive  
Carrollton, GA 30119  
Attn: General Counsel  
Facsimile: (770) 832-5374

Each Party shall have the right to change the name of the person or location to whom or where notice shall be given or served by notifying the other Party in writing of such change.

ARTICLE IX  
REPRESENTATIONS AND WARRANTIES

9.01 Representations of Seller. Seller hereby represents and warrants to Customer as follows:

(a) Seller is an electric cooperative corporation duly organized, validly existing and in good standing under the laws of the Commonwealth of Kentucky, and has the power and authority to execute and deliver this Agreement, to perform its obligations hereunder, and to carry on its business as such business is now being conducted and as is contemplated hereunder to be conducted during the term hereof.

(b) The execution, delivery, and performance of this Agreement by Seller have been duly and effectively authorized by all requisite corporate action.

9.02 Representations and Warranties of Customer. Customer hereby represents and warrants to Seller as follows:

(a) Customer is a corporation duly organized and validly existing and in good standing under the laws of the State of Delaware, is authorized to do business in the Commonwealth of Kentucky, and has the power and authority to execute and deliver this Agreement, to perform its obligations hereunder, and to carry on its business as such business is now being conducted and as is contemplated hereunder to be conducted during the term hereof.

(b) The execution, delivery, and performance of this Agreement by Customer have been duly and effectively authorized by all requisite corporate action.

ARTICLE X  
SEVERABILITY

10.01 The invalidity of any portion of this Agreement shall not affect the validity of the remainder thereof.

ARTICLE XI  
SUCCESSION, APPROVAL, AND EFFECTIVE DATE

11.01 This Agreement shall be binding upon and inure to the benefit of the successors, legal representatives, and permitted assigns of the respective Parties hereto.

11.02 The “Effective Date” of this Agreement shall be the date hereof, except that said Effective Date shall be postponed and this Agreement shall not become effective unless and until this Agreement is approved or accepted in writing by the Commission, the Delivery Point Agreement is executed as contemplated in Section 1.01, and the 2009 Wholesale Power Agreement Amendment is approved or accepted in writing by the Commission and, if required, by the Rural Utilities Service of the U. S. Department of Agriculture, and the 1998 Retail Agreement has been terminated.

## ARTICLE XII MISCELLANEOUS

12.01 Entire Agreement. The terms, covenants, and conditions contained in this Agreement and the Delivery Point Agreement constitute the entire agreement between the Parties and shall supersede all previous communications, representations, or agreements, either oral or written, between the Parties hereto with respect to the subject matter hereof, provided, however, that service to Customer is subject to the lawful orders of the Commission.

12.02 Governing Law, Jurisdiction, and Venue. All respective rights and obligations of the Parties shall be governed by the laws of the Commonwealth of Kentucky and the rules, regulations and orders of the Commission, without regard to its conflicts of law rules. The Parties hereby agree that the courts of the Commonwealth of Kentucky will have exclusive jurisdiction over each and every judicial action brought under or in relationship to this Agreement; provided that the subject matter of such dispute is not a matter reserved by law to the Commission, or to the U.S. federal judicial system (in which event exclusive jurisdiction and venue will lie with the U.S. District Court for the Western District of Kentucky), and the Parties hereby agree to submit to the jurisdiction of Kentucky courts for such purpose. Venue of any state court action, legal or equitable, related to this Agreement shall be Henderson County, Kentucky.

12.03 Waiver. The waiver by either Party of any breach of any term, covenant, or condition contained herein will not be deemed a waiver of any other term, covenant, or condition, nor will it be deemed a waiver of any subsequent breach of the same or any other term, covenant, or condition contained herein.

12.04 Amendments. This Agreement may be amended, revised, or modified by, and only by, a written instrument duly executed by both Parties.

12.05 Counterparts. This Agreement may be executed in any number of counterparts, which together will constitute but one and the same instrument, and each counterpart will have the same force and effect as if they were one original.

12.06 Headings. The headings contained in this Agreement are solely for convenience and do not constitute a part of the agreement between the Parties, nor should such headings be used to aid in any manner in the construction of this Agreement.

IN WITNESS WHEREOF, the Parties hereto have executed this Agreement, as of the day and year first above written.

KENERGY CORP.

By: \_\_\_\_\_  
Sanford Novick  
President and CEO

SOUTHWIRE COMPANY

By: \_\_\_\_\_  
Printed Name: \_\_\_\_\_  
Title: \_\_\_\_\_

July \_\_, 2009

RECEIVED

JUN 25 2009

PUBLIC SERVICE  
COMMISSION

Mr. Sanford Novick  
Kenergy Corp.  
6402 Corydon Road  
P.O. Box 18  
Henderson, KY 42419-0018

Re: Retail Electric Service Agreement  
Southwire Company Rod & Cable

Dear Sandy:

This letter agreement ("Letter Agreement") will evidence Big Rivers' concurrence with the terms of Kenergy's electric service agreement with Southwire Company (the "Retail Customer") for its rod and cable mill dated July \_\_, 2009, a copy of which is attached hereto as Exhibit 1 (the "Retail Agreement"), and the agreement between Big Rivers and Kenergy with respect thereto.

(1) **Existing Agreement and Tariffs.** The terms and conditions of the June 11, 1962, wholesale power agreement, as amended, and Big Rivers' filed tariffs shall continue in full force and effect except as expressly modified by this Letter Agreement.

(2) **Additional Rights and Obligations of Big Rivers.** Big Rivers shall make available to Kenergy the electric power required during the term of the Retail Agreement to perform the power supply obligations assumed by Kenergy in the Retail Agreement and Big Rivers shall have the benefit of Retail Customer's covenants in such agreement. Big Rivers will supply the facilities required to deliver power to Kenergy (i) at the Existing Delivery Point, as defined in the Retail Agreement, or (ii) if the Prospective Delivery Point is established, as defined and specified in the Retail Agreement, then at the point where Kenergy's distribution facilities attach to Big Rivers' transmission substation (National Aluminum substation), and Kenergy will deliver the power over its distribution facilities to the Prospective Delivery Point. Big Rivers will supply the facilities to meter electrical usage by Retail Customer. If Retail Customer satisfies its obligation under the Retail Agreement to provide security for the Transmission Facilities Costs with a cash deposit, Kenergy will pay the cash deposit to Big Rivers, and Big Rivers will perform, through Kenergy, Kenergy's legal obligations to Retail Customer respecting that cash deposit, including payment of interest on that deposit as required by law.

(3) **Obligations of Kenergy.** Kenergy shall take and pay for (i) electric power and energy delivered by Big Rivers in accordance with Big Rivers' Rate Schedule 7 or Rate Schedule 10, as applicable, with demand and energy being measured as follows: (a) During the period in which the wholesale delivery point is the Existing Delivery Point, by the existing meters at the Southwire Rod & Cable Mill, described in the Retail Agreement as the Southwire Metering Point and in accordance with the terms of said Retail Agreement, and (b) during the period when the wholesale delivery point is to Kenergy's distribution facilities for redelivery to Retail Customer at the Prospective Delivery Point, by the meters to be installed in the Big Rivers National Aluminum transmission substation as shown on Exhibit A to the Retail Agreement, and (ii) transmission services and facilities charges incurred by Big Rivers in connection with extending service to the Retail Customer's delivery point. Kenergy will promptly forward to Big Rivers a copy of any notices received by Kenergy from the Retail Customer under the terms of the Retail Agreement.

(4) **Obligation of Kenergy for Minimum Billing Demand Charge.** Kenergy agrees to bill Retail Customer for (i) any minimum billing demand charges in excess of measured demand, and (ii) all transmission services and facilities charges incurred by Big Rivers and billed to Kenergy in connection with extending service to the Retail Customer's delivery point. Kenergy agrees to pay over to Big Rivers all funds actually collected under such billings, including any termination charges respecting the Big Rivers Transmission Facilities (as that term is defined in the Retail Agreement). The terms of this paragraph do not affect the obligation of Kenergy to pay Big Rivers in accordance with Big Rivers' tariff as and when billed for the wholesale charges for electric power and energy actually consumed by Retail Customer.

(5) **Division of Any Partial Payments.** Kenergy will pay to Big Rivers a pro rata share of any partial payment made to Kenergy by or on behalf of Retail Customer.

(6) **Effective Date.** This Letter Agreement will become effective upon the latter to occur of approval or acceptance of this Letter Agreement by the Public Service Commission of Kentucky, and the effective date of the Retail Agreement.

(7) **Entire Agreement and Amendment.** This Letter Agreement represents the entire agreement of the parties on the subject matter herein, and cannot be amended except in writing, duly authorized and signed by Big Rivers and Kenergy. The Retail Agreement cannot be amended without the written approval of Big Rivers. Big Rivers shall have the right to approve the terms and issuer(s) of the letter(s) of credit contemplated by the Retail Agreement to secure the obligations of the Retail Customer for termination charges.

If this Letter Agreement is acceptable to Kenergy, please indicate that acceptance by signing in the space provided and returning four copies to us.

Sincerely yours,  
BIG RIVERS ELECTRIC CORPORATION

\_\_\_\_\_  
Mark A. Bailey, President/CEO

ACCEPTED:

KENERGY CORP.

\_\_\_\_\_  
Sanford Novick  
President/CEO

Date: \_\_\_\_\_



July \_\_, 2009

RECEIVED

JUN 25 2009

PUBLIC SERVICE  
COMMISSION

Mr. Sanford Novick  
Kenergy Corp.  
6402 Corydon Road  
P.O. Box 18  
Henderson, KY 42419-0018

Re: Retail Electric Service Agreement  
Southwire Company Rod & Cable

Dear Sandy:

This letter agreement ("Letter Agreement") will evidence Big Rivers' concurrence with the terms of Kenergy's electric service agreement with Southwire Company (the "Retail Customer") for its rod and cable mill dated July \_\_, 2009, a copy of which is attached hereto as Exhibit 1 (the "Retail Agreement"), and the agreement between Big Rivers and Kenergy with respect thereto.

Deleted: May

(1) **Existing Agreement and Tariffs.** The terms and conditions of the June 11, 1962, wholesale power agreement, as amended, and Big Rivers' filed tariffs shall continue in full force and effect except as expressly modified by this Letter Agreement.

(2) **Additional Rights and Obligations of Big Rivers.** Big Rivers shall make available to Kenergy the electric power required during the term of the Retail Agreement to perform the power supply obligations assumed by Kenergy in the Retail Agreement and Big Rivers shall have the benefit of Retail Customer's covenants in such agreement. Big Rivers will supply the facilities required to deliver power to Kenergy (i) at the Existing Delivery Point, as defined in the Retail Agreement, or (ii) if the Prospective Delivery Point is established, as defined and specified in the Retail Agreement, then at the point where Kenergy's distribution facilities attach to Big Rivers' transmission substation (National Aluminum substation), and Kenergy will deliver the power over its distribution facilities to the Prospective Delivery Point. Big Rivers will supply the facilities to meter electrical usage by Retail Customer. If Retail Customer satisfies its obligation under the Retail Agreement to provide security for the Transmission Facilities Costs with a cash deposit, Kenergy will pay the cash deposit to Big Rivers, and Big Rivers will perform, through Kenergy, Kenergy's legal obligations to Retail Customer respecting that cash deposit, including payment of interest on that deposit as required by law.

Deleted: delivery point

(3) **Obligations of Kenergy.** Kenergy shall take and pay for (i) electric power and energy delivered by Big Rivers in accordance with Big Rivers' Rate Schedule 7 or Rate Schedule 10, as applicable, with demand and energy being measured as follows: (a) During the period in which the wholesale delivery point is the Existing Delivery Point, by the existing

\_\_\_\_\_ meters at the Southwire Rod & Cable Mill, described in the Retail Agreement as the Southwire Metering Point and in accordance with the terms of said Retail Agreement, and (b) during the period when the wholesale delivery point is to Kenergy's distribution facilities for redelivery to Retail Customer at the Prospective Delivery Point, by the meters to be installed in the Big Rivers National Aluminum transmission substation as shown on Exhibit A to the Retail Agreement, and (ii) transmission services and facilities charges incurred by Big Rivers in connection with extending service to the Retail Customer's delivery point. Kenergy will promptly forward to Big Rivers a copy of any notices received by Kenergy from the Retail Customer under the terms of the Retail Agreement.

(4) **Obligation of Kenergy for Minimum Billing Demand Charge.** Kenergy agrees to bill Retail Customer for (i) any minimum billing demand charges in excess of measured demand, and (ii) all transmission services and facilities charges incurred by Big Rivers and billed to Kenergy in connection with extending service to the Retail Customer's delivery point. Kenergy agrees to pay over to Big Rivers all funds actually collected under such billings, including any termination charges respecting the Big Rivers Transmission Facilities (as that term is defined in the Retail Agreement). The terms of this paragraph do not affect the obligation of Kenergy to pay Big Rivers in accordance with Big Rivers' tariff as and when billed for the wholesale charges for electric power and energy actually consumed by Retail Customer.

(5) **Division of Any Partial Payments.** Kenergy will pay to Big Rivers a pro rata share of any partial payment made to Kenergy by or on behalf of Retail Customer.

(6) **Effective Date.** This Letter Agreement will become effective upon the latter to occur of approval or acceptance of this Letter Agreement by the Public Service Commission of Kentucky, and the effective date of the Retail Agreement.

(7) **Entire Agreement and Amendment.** This Letter Agreement represents the entire agreement of the parties on the subject matter herein, and cannot be amended except in writing, duly authorized and signed by Big Rivers and Kenergy. The Retail Agreement cannot be amended without the written approval of Big Rivers. Big Rivers shall have the right to approve the terms and issuer(s) of the letter(s) of credit contemplated by the Retail Agreement to secure the obligations of the Retail Customer for termination charges.

If this Letter Agreement is acceptable to Kenergy, please indicate that acceptance by signing in the space provided and returning four copies to us.

Sincerely yours,  
BIG RIVERS ELECTRIC CORPORATION

\_\_\_\_\_  
Mark A. Bailey, President/CEO

ACCEPTED:

KENERGY CORP.

\_\_\_\_\_  
Sanford Novick  
President/CEO

Date: \_\_\_\_\_

DELIVERY POINT AGREEMENT

This agreement ("Agreement") is made and entered into on this the \_\_\_ day of July, 2009, between and among KENERGY CORP., a Kentucky electric cooperative corporation, with its principal office located at 6402 Old Corydon Road, P.O. Box 18, Henderson, Kentucky 42419-0018 ("Kenergy"), BIG RIVERS ELECTRIC CORPORATION, a Kentucky electric cooperative corporation, with its principal office located at 201 Third Street, Henderson, KY 42420 ("Big Rivers"), SOUTHWIRE COMPANY, a Delaware corporation, with its principal office located at One Southwire Drive, Carrollton, GA 30119 ("Southwire") and CENTURY ALUMINUM OF KENTUCKY GENERAL PARTNERSHIP, a Kentucky general partnership, with its principal office located at 500 State Route 271 North, Hawesville, Kentucky 42348 ("Century"). Kenergy, Big Rivers, Southwire and Century are individually referred to herein as a "Party" and collectively as the "Parties".

WHEREAS, Southwire and Green River Electric Corporation ("GREC"), Kenergy's predecessor in interest, entered into an Agreement for Electric Service dated July 15, 1998, (as amended, the "1998 Retail Agreement"), and related agreements, under which GREC agreed to supply electric service to Southwire for use at Southwire's primary aluminum smelter ("Smelter") and Southwire's adjacent rod and cable mill ("Rod and Cable Mill"), both located in Hancock County, Kentucky;

WHEREAS, Century now owns the Smelter and the physical assets through which both the Smelter and the Rod and Cable Mill accept electric service at the existing set of meters at Big Rivers' Coleman substation (the "Century Delivery Point");

WHEREAS, Century now also owns the physical assets through which electric power and energy is both transformed and delivered from the Century Delivery Point to the existing set of meters at which the Rod and Cable Mill accepts electric service at 13,800 volts (the "Southwire Metering Point"), such physical assets from the Century Delivery Point to the Southwire Metering Point being referred to herein as the "Southwire Interconnection";

WHEREAS, Kenergy and Southwire have entered into a new retail electric service agreement of even date herewith (the "2009 Retail Agreement") that anticipates establishment of a new, dedicated delivery point for electric service to the Rod and Cable Mill that cannot be completed prior to the effective date of such agreement; and

WHEREAS, the Parties desire to enter into this Agreement that will allow the delivery point for power and energy under the 2009 Retail Agreement to be the Century Delivery Point until the necessary transmission and distribution facilities required to establish a new dedicated delivery point for the Rod and Cable Mill (the "Prospective Delivery Point" as defined in the 2009 Retail Agreement) can be constructed.

NOW, THEREFORE, in consideration of the mutual covenants contained herein, the Parties agree as follows:

1. Basic Obligations. Century agrees that Kenergy, through Big Rivers, may deliver electric power and energy to the Rod and Cable Mill under the 2009 Retail Agreement at the Century Delivery Point until the Prospective Delivery Point becomes commercially operable. Kenergy and Big Rivers agree to proceed with the construction of the distribution and transmission facilities required to establish the Prospective Delivery Point with all reasonable dispatch following the effective date of the 2009 Retail Agreement. Southwire agrees to accept delivery of electric power and energy under the 2009 Retail Agreement at the Century Delivery Point until the Prospective Delivery Point becomes commercially operable.

2. Metering and Billing. The Parties agree that, for the period that the Century Delivery Point remains in use for purposes of the 2009 Retail Agreement; (a) the electric power and energy delivered by Kenergy to Southwire for the Rod and Cable Mill shall be metered for billing purposes at the Southwire Metering Point; (b) for purposes of monthly billings by Kenergy to Southwire, for purposes of monthly billings by Seller to Customer, the billing determinants for monthly and hourly energy shall be adjusted based on the actual meter readings at the Southwire Metering Point, plus one percent (1%) to compensate Century for energy losses on the Southwire Interconnection; and (c) for purposes of monthly billing by Kenergy to Century pursuant to that certain "Retail Electric Service Agreement" between Kenergy and Century of even date herewith, the billing determinants for monthly and hourly demand, energy and reactive demand as determined by meter readings at the Century Delivery Point shall be reduced by subtracting the corresponding billing determinants, as adjusted, for the Rod and Cable Mill.

3. Payment Obligations and Indemnifications.

a. Kenergy and Big Rivers agree to indemnify, release and hold harmless Century for any and all payment obligations of Southwire to Kenergy and Big Rivers, including but not limited to payment obligations incurred by Southwire under the 2009 Retail Agreement, and further agree that in the event of Southwire's non-payment of any obligation or any other occurrence that would result in the physical termination of electric service by Kenergy to the Rod and Cable Mill during the term of this Agreement, such physical termination shall be effected by disconnection either at the Southwire Metering Point or at the Century Delivery Point. Century agrees that it will disconnect electric service to Southwire on a date and at a time directed by Kenergy, provided that (i) Century shall be responsible for the means, methods and techniques employed to implement the disconnection, and (ii) Kenergy agrees to defend, indemnify, release and hold harmless Century and each of its directors, officers, employees and agents from and against any and all claims, demands, causes of action, liabilities, damages, judgments, fines, penalties, awards, losses, costs, expenses of any kind or character, including, without limitation, reasonable attorney's fees and costs of litigation, which it or they may sustain in favor of Southwire as a result of following such direction from Kenergy to disconnect electric service to Southwire.

b. Kenergy and Big Rivers agree to indemnify, release and hold harmless Southwire for any and all payment obligations of Century to Kenergy and Big Rivers, including but not limited to payment obligations incurred by Century under the Retail Electric Service Agreement.

c. Southwire agrees to indemnify, release and hold harmless Kenergy and Big Rivers for any failure of Kenergy and Big Rivers to deliver power and energy to the Rod and Cable Mill resulting from a proper implementation of a remedy by Kenergy against Century, including a disconnection of electric service at the Century Delivery Point. During the term of this Agreement, if Kenergy issues to either Century or Southwire a notice of intent to disconnect electric service for non-payment, a copy of that notice shall be delivered to both Century and Southwire to provide them with the opportunity to make appropriate alterations to the equipment within the Southwire Interconnection or the Century Delivery Point to preserve continuity of service to the Party that is not in default on its payment obligations, provided that neither Kenergy nor Big Rivers shall have any responsibility to make or participate in the costs of making any such alterations.

d. Southwire agrees to defend, indemnify, release and hold harmless each of Kenergy and Big Rivers and each of their respective directors, officers, employees and agents from and against any and all claims, demands, causes of action, liabilities, damages, judgments, fines, penalties, awards, losses, costs, expenses of any kind or character, including, without limitation, reasonable attorney's fees and costs of litigation, which they may sustain for damage to or loss of any real or personal property (including property of the companies or agencies) and for personal injury to or illness or death of any person or entity in any way attributable to the handling, transmittal and use of the electric power and energy delivered to the Century Delivery Point under the 2009 Retail Agreement from the moment it is delivered to the Century Delivery Point through the point in time it is used by the Rod and Cable Mill, regardless of whether same resulted from Southwire's claimed or actual, sole or joint, negligence (including subcontractors, agents, or employees) or Century's, Kenergy's or Big Rivers' claimed or actual, sole or joint, negligence (including their subcontractors, agents or employees), or any combination of these.

4. Reactive Power. Century and Southwire acknowledge and agree that Southwire is entitled to receive, with respect to the Rod and Cable Mill, an entitlement to 4,000 kilovars acquired by Southwire pursuant to the 1998 Retail Agreement, as amended, for the purpose of financially mitigating the reactive demand incurred at the Rod and Cable Mill in excess of the reactive demand, measured in kilovars, to which Southwire otherwise would be entitled without further compensation based on the Rod and Cable Mill's monthly billing demand and a power factor of ninety percent (90%). This Section 4 shall survive this Agreement and shall remain in full force and effect for so long as any agreement for electric service between Kenergy and Southwire (for the benefit of the Rod and Cable Mill) shall remain in effect.

5. Notice. Any notice, demand, or request required or authorized under this Agreement shall be deemed properly given to or served upon the other Party if the notice is in writing and placed in this mail, postage prepaid, or delivered to the other Party at the following addresses:

If to Kenergy:	Kenergy Corp. 6402 Old Corydon Road Henderson, Kentucky 42420 Facsimile: (270) 830-6934 Attn: President and CEO
If to Big Rivers:	Big Rivers Electric Corporation 201 Third Street Henderson, Kentucky 42420 Facsimile: (270) 827-2558 Attn: President and CEO
If to Century:	Century Aluminum Company P.O. Box 500 State Route 271 North Hawesville, Kentucky 42348 Attn: Plant Manager Facsimile: (270) 852-2882
With a copy to:	Century Aluminum Company 2511 Garden Road Building A, Suite 200 Monterey, CA 93940 Attn: General Counsel Facsimile: (831) 642-9328
If to Southwire:	Southwire Company One Southwire Drive Carrollton, GA 30119 Attn: General Counsel Facsimile: (770) 832-5374

Each Party shall have the right to change the name of the person or location to whom or where notice shall be given or served by notifying the other Parties in writing of such change.

6. Severability. The invalidity of any portion of this Agreement shall not affect the validity of the remainder thereof.

7. Succession. This Agreement shall be binding upon and inure to the benefit of the successors, legal representatives, and permitted assigns of the respective Parties hereto.

8. Effective Date. The “Effective Date” of this Agreement shall be the date hereof, except that said Effective Date shall be postponed and this Agreement shall not become effective unless and until the 2009 Retail Agreement is approved or accepted in writing by the Kentucky Public Service Commission (the “Commission”), the 2009 Wholesale Power Agreement Amendment (as defined in the 2009 Retail Agreement) is approved or accepted in writing by the Commission and the Rural Utilities Service of the U. S. Department of Agriculture, and the 1998 Retail Agreement shall have been terminated.

9. Termination Date. This Agreement shall terminate and be of no further force or effect upon the earlier to occur of (a) the first day of the calendar month following the calendar month in which the Prospective Delivery Point shall become commercially operable, or (b) the date on which the 2009 Retail Agreement shall terminate or expire. Kenergy shall be responsible for notifying the other Parties of the termination date of this Agreement upon the occurrence of either of the events set forth in the prior sentence.

10. Entire Agreement. The terms, covenants, and conditions contained herein constitute the entire agreement among the Parties and shall supersede all previous communications, representations, or agreements, either oral or written, between the Parties hereto with respect to the terms applicable to the temporary use by Kenergy, Big Rivers and Southwire of the Century Delivery Point, the Southwire Interconnection, and the Southwire Metering Point.

11. Governing Law, Jurisdiction, and Venue. All respective rights and obligations of the Parties shall be governed by the laws of the Commonwealth of Kentucky, without regard to its conflicts of law rules. The Parties hereby agree that the courts of the Commonwealth of Kentucky will have exclusive jurisdiction over each and every judicial action brought under or in relationship to this Agreement; provided that the subject matter of such dispute is not a matter reserved by law to the Commission, or to the U.S. federal judicial system (in which event exclusive jurisdiction and venue will lie with the U.S. District Court for the Western District of Kentucky), and the Parties hereby agree to submit to the jurisdiction of Kentucky courts for such purpose. Venue of any state court action, legal or equitable, related to this Agreement shall be Henderson County, Kentucky.

12. Waiver. The waiver by either Party of any breach of any term, covenant, or condition contained herein will not be deemed a waiver of any other term, covenant, or condition, nor will it be deemed a waiver of any subsequent breach of the same or any other term, covenant, or condition contained herein.

13. Amendments. This Agreement may be amended, revised, or modified by, and only by, a written instrument duly executed by all Parties.



14. Counterparts. This Agreement may be executed in any number of counterparts, which together will constitute but one and the same instrument, and each counterpart will have the same force and effect as if they were one original.

15. Headings. The headings contained in this Agreement are solely for convenience and do not constitute a part of the agreement between and among the Parties, nor should such headings be used to aid in any manner in the construction of this Agreement.

IN WITNESS WHEREOF, the Parties hereto have executed this Agreement, as of the day and year first above written.

KENERGY CORP.

By: \_\_\_\_\_  
Sanford Novick  
President and CEO

BIG RIVERS ELECTRIC CORPORATION

By: \_\_\_\_\_  
Mark A. Bailey  
President and CEO

SOUTHWIRE COMPANY

By: \_\_\_\_\_  
Printed Name: \_\_\_\_\_  
Title: \_\_\_\_\_

CENTURY ALUMINUM OF KENTUCKY GENERAL PARTNERSHIP

By: \_\_\_\_\_  
Printed Name: \_\_\_\_\_  
Title: \_\_\_\_\_