

AGREEMENT

between

BellSouth Telecommunications, Inc.

and

AT&T Communications of the South Central States, Inc.

Effective Date:

KENTUCKY

TABLE OF CONTENTS

<u>Section</u>	<u>Page</u>
AGREEMENT	4
PREFACE	4
RECITALS	4
DEFINITIONS and ACRONYMS.....	4
GENERAL TERMS AND CONDITIONS	4
1. Provision of Local Service and Unbundled Network Elements.....	5
2. Term of Agreement.....	6
3. Termination of Agreement; Transitional Support.....	6
4. Good Faith Performance.....	7
5. Option to Obtain Services and Elements and Combinations Under Other Agreements	7
6. Responsibility of Each Party	7
7. Governmental Compliance	8
8. Responsibility For Environmental Contamination	8
9. Regulatory Matters	11
10. Liability and Indemnity.....	11
11. Intellectual Property Rights and Indemnification	14
12. Audits and Inspections	17
13. Performance Measurement	18
14. Force Majeure	19
15. Certain Federal, State and Local Taxes.....	19
16. Dispute Resolution Process.....	23
17. Notices	24

18. Confidentiality and Proprietary Information.....	25
19. Branding.....	27
20. Directory Listings Requirements	27
21. Insurance Requirements.....	29
22. Costs	30
23. Disaster Recovery	30
24. Miscellaneous.....	30
25. Reservation of Rights	34

ATTACHMENTS

Attachment 1	Resale
Attachment 2	Unbundled Network Elements
Attachment 3	Local Interconnection
Attachment 4	Collocation
Attachment 5	Access to Numbers and Number Portability
Attachment 6	Connectivity Billing and Recording
Attachment 7	Interface Requirements for Ordering and Provisioning, Maintenance and Repair, and Pre-Ordering
Attachment 8	Rights of Way (ROW), Conduits, and Pole Attachments
Attachment 9	Performance Measures
Attachment 10	Bona Fide Request/New Business Request Process
Attachment 11	Acronyms
Attachment 12	Network Security
Attachment 13	BAPCO Agreement
Exhibit A	Disaster Recovery

AGREEMENT

PREFACE

This Agreement, which shall become effective as of the 20th day of July, 2000, is entered into by and between AT&T Communications of the South Central States, Inc., a Delaware corporation, ("AT&T"), having an office at 1200 Peachtree Street, N.E., Atlanta, Georgia, 30309, and BellSouth Telecommunications, Inc. ("BellSouth"), a Georgia corporation, having an office at 675 West Peachtree Street, Atlanta, Georgia 30375, on behalf of itself and its successors and assigns.

RECITALS

WHEREAS, The Telecommunications Act of 1996 (the "Act") was signed into law on February 8, 1996; and

WHEREAS, the Act places certain duties and obligations upon, and grants certain rights to Telecommunications Carriers; and

WHEREAS, BellSouth is an Incumbent Local Exchange Carrier; and

WHEREAS, AT&T is a Telecommunications Carrier and has requested that BellSouth negotiate an Agreement pursuant to the Act,

NOW, THEREFORE, in consideration of the promises and the mutual covenants of this Agreement, AT&T and BellSouth hereby agree as follows:

DEFINITIONS and ACRONYMS

For purposes of this Agreement, certain terms have been defined in the body of the Agreement to encompass meanings that may differ from, or be in addition to, the normal connotation of the defined word. Unless the context clearly indicates otherwise, any term defined or used in the singular shall include the plural. The words "shall" and "will" are used interchangeably throughout this Agreement and the use of either connotes a mandatory requirement. The use of one or the other shall not mean a different degree of right or obligation for either Party. A defined word intended to convey its special meaning is capitalized when used. Other terms that are capitalized, and not defined in this Agreement, shall have the meaning in the Act. For convenience of reference, Attachment 11 provides a list of acronyms used throughout this Agreement.

GENERAL TERMS AND CONDITIONS

1. **Provision of Local Service and Unbundled Network Elements**
- 1.1 This Agreement sets forth the terms, conditions and prices under which BellSouth agrees to provide: (a) telecommunications services that BellSouth currently provides, or may offer hereafter for resale; (b) interconnection of BellSouth's network to AT&T's network; (c) certain unbundled Network Elements ("Network Elements") and certain combinations of such unbundled Network Elements ("Combinations"); (d) access to poles, rights of way and conduits; and (e) collocation (resale, interconnection, Network Elements and Combinations, access to rights of way, poles and conduits, and collocation shall collectively be referred to as "Services and Elements"). BellSouth may fulfill the requirements imposed upon it by this Agreement by itself or, in the case of directory listings for white pages may cause BellSouth Advertising and Publishing Company ("BAPCO") to take such actions to fulfill BellSouth's responsibilities. This Agreement includes Attachments 1 – 13 and all accompanying Appendices and Exhibits. Unless otherwise provided in this Agreement, BellSouth will perform all of its obligations hereunder throughout its entire service area.
- 1.2 Subject to the requirements of this Agreement, AT&T may, at any time add, relocate or modify any Services and Elements purchased hereunder. Requests for additions or other changes shall be handled pursuant to the process provided in Attachment 10. Terminations of any Services or Elements shall be handled pursuant to Section 3 of the General Terms and Conditions of this Agreement.
- 1.3 BellSouth shall not discontinue Services and Elements provided hereunder without the prior written consent of AT&T. Such consent shall not be unreasonably withheld; provided, however, BellSouth may discontinue any telecommunications service available for resale as long as BellSouth provides AT&T prior written notice of intent to discontinue any such service. BellSouth further agrees to make any such service available to AT&T for resale to AT&T's end users who are subscribers of such services from AT&T until the date BellSouth discontinues any such service for BellSouth's customers. BellSouth also agrees to adopt a reasonable, nondiscriminatory transition schedule for BellSouth or AT&T end users who may be purchasing any such service.
- 1.4 This Agreement may be amended from time to time as mutually agreed in writing between the Parties. The Parties agree that neither Party will take any action to proceed, nor shall either have any obligation to proceed on a requested change unless and until a modification to this Agreement is signed by authorized representatives of each Party.

2. **Term of Agreement**

2.1 When executed by authorized representatives of BellSouth and AT&T, this Agreement shall become effective as of the Effective Date stated above, and shall expire three (3) years from the Effective Date unless terminated in accordance with the provisions of Section 3.2 of the General Terms and Conditions.

2.2 The Parties agree that by no later than one hundred and eighty (180) days prior to the expiration of this Agreement, they may commence negotiations for a subsequent agreement ("Subsequent Agreement") with regard to the terms, conditions and obligations contained in this Agreement.

2.3 If, within one hundred and thirty-five (135) days of commencing the negotiation referred to in Section 2.2, above, the Parties are unable to satisfactorily negotiate the Subsequent Agreement, either Party may petition the Commission to establish appropriate terms and conditions for those unresolved issues pursuant to 47 U.S.C. 252. If the Commission fails to issue an order setting new terms and conditions prior to the expiration of this Agreement, the terms of this agreement shall continue in effect, on a month-to-month basis, at the same terms, conditions and prices as those in effect at the end of the then-current term, until resolved by the Commission.

2.4 The Parties must have commenced good faith negotiations within the time period set forth in Sections 2.2 and 2.3 of the Terms and Conditions of this Agreement in order for the Agreement to continue on a month-to-month basis. If such good faith negotiations have not commenced, unless the Parties agree otherwise, the Parties agree to submit the issue of having this Agreement continued on a month-to-month basis to the appropriate Commission. If such a request is made to the Commission, this Agreement will remain in effect on a month-to-month basis until the Commission has ruled.

3. **Termination of Agreement; Transitional Support**

3.1 AT&T may terminate any Services and Elements provided under this Agreement upon thirty (30) days written notice to BellSouth unless a different notice period or different conditions are specified for termination of such Services and Elements in this Agreement or pursuant to any applicable tariff, in which event such specific period or conditions shall apply, provided such period or condition is reasonable, nondiscriminatory and narrowly tailored. Where there is no such different notice period or different condition specified, AT&T's liability shall be limited to payment of the amounts due for any terminated Services and Elements provided up to and including the date of termination. Notwithstanding the foregoing, the provisions of Section

10, infra, shall still apply. Upon termination, BellSouth agrees to cooperate in an orderly and efficient transition to AT&T or another vendor such that the level and quality of the Services and Elements is not degraded and to exercise its best efforts to effect an orderly and efficient transition. AT&T agrees that it may not terminate the entire Agreement pursuant to this section.

3.2 If a Party is in breach of a material term or condition of this Agreement (“Defaulting Party”), the other Party shall provide written notice of such breach to the Defaulting Party. The Defaulting Party shall have ten (10) business days from receipt of notice to cure the breach. If the breach is not cured, the Parties shall follow the dispute resolution procedure set forth in Section 16 of the General Terms and Conditions of this Agreement.

4. **Good Faith Performance**

4.1 In the performance of their obligations under this Agreement, the Parties shall act in good faith and consistently with the intent of the Act. Where notice, approval or similar action by a Party is permitted or required by any provision of this Agreement, (including, without limitation, the obligation of the Parties to further negotiate the resolution of new or open issues under this Agreement) such action shall not be unreasonably delayed, withheld or conditioned.

5. **Option to Obtain Services and Elements and Combinations Under Other Agreements**

5.1 BellSouth shall make available and AT&T may elect to adopt pursuant to 47 U.S.C. § 252 and the FCC rules and regulations regarding such availability any interconnection, service, or network element provided under an agreement approved pursuant to 47 U.S.C. § 252. The adopted interconnection, service, or network element shall apply to the same states as such other agreement and for the identical term of such other agreement. AT&T may exercise this option by delivering written notice to BellSouth, which may include a proposed amendment to this Agreement to incorporate the prices, terms and conditions, in whole or in part found in the other agreement.

5.2 Any dispute between the Parties concerning any election or exercise of an option by AT&T under this Section 5 shall be resolved pursuant to the dispute resolution procedure set forth in Section 16 of the General Terms and Conditions of this Agreement.

6. **Responsibility of Each Party**

6.1 Each Party is an independent contractor, and has and hereby retains the right to exercise full control of and supervision over its own performance of its obligations under this Agreement and retains full control over the employment, direction, compensation and discharge of all employees assisting in the performance of such obligations. Each Party will be solely responsible for all matters relating to payment of such employees, including compliance with social security taxes, withholding taxes and all other regulations governing such matters. Each Party will be solely responsible for proper handling, storage, transport and disposal at its own expense of all (i) substances or materials that it or its contractors or agents bring to, create or assume control over at Work Locations or, (ii) Waste resulting therefrom or otherwise generated in connection with its or its contractors' or agents' activities at the Work Locations. Subject to the limitations on liability and except as otherwise provided in this Agreement, each Party shall be responsible for (i) its own acts and performance of all obligations imposed by Applicable Law in connection with its activities, legal status and property, real or personal and, (ii) the acts of its own affiliates, employees, agents and contractors during the performance of that Party's obligations hereunder.

7. **Governmental Compliance**

7.1 AT&T and BellSouth each shall comply at its own expense with all Applicable Law that relates to (i) its obligations under or activities in connection with this Agreement or (ii) its activities undertaken at, in connection with or relating to Work Locations. AT&T and BellSouth each agree to indemnify, defend (at the other Party's request) and save harmless the other, each of its officers, directors and employees from and against any losses, damages, claims, demands, suits, liabilities, fines, penalties and expenses (including reasonable attorneys' fees) that arise out of or result from (i) its failure or the failure of its contractors or agents to so comply or (ii) any activity, duty or status of it or its contractors or agents that triggers any legal obligation to investigate or remediate environmental contamination. BellSouth, at its own expense, will be solely responsible for obtaining from governmental authorities, building owners, other carriers, and any other persons or entities, all rights and privileges (including, but not limited to, space and power), which are necessary for BellSouth to provide the Services and Elements pursuant to this Agreement. AT&T, at its own expense, will be solely responsible for obtaining from governmental authorities, building owners, other carriers, and any other persons or entities, all rights and privileges which are AT&T's obligation as a provider of telecommunications services to its end users pursuant to this Agreement.

8. **Responsibility For Environmental Contamination**

- 8.1 AT&T shall in no event be liable to BellSouth for any costs whatsoever resulting from the presence or Release of any Environmental Hazard or Hazardous Materials that AT&T did not introduce to the affected Work Location so long as AT&T's actions do not cause or substantially contribute to the release of any Environmental Hazard or Hazardous Materials. BellSouth shall indemnify, defend (at AT&T's request) and hold harmless AT&T, each of its officers, directors and employees from and against any losses, damages, claims, demands, suits, liabilities, fines, penalties and expenses (including reasonable attorneys' fees) that arise out of or result from (i) any Environmental Hazard or Hazardous Materials that BellSouth, its contractors or agents introduce to the Work Locations or (ii) the presence or Release of any Environmental Hazard or Hazardous Materials for which BellSouth is responsible under Applicable Law, to the extent the release of any Environmental Hazard or Hazardous Materials is not caused or substantially contributed to by AT&T's actions.
- 8.2 BellSouth shall in no event be liable to AT&T for any costs whatsoever resulting from the presence or Release of any Environmental Hazard or Hazardous Materials that BellSouth did not introduce to the affected Work Location, so long as BellSouth's actions do not cause or substantially contribute to the release of any Environmental Hazards or Hazardous Materials. AT&T shall indemnify, defend (at BellSouth's request) and hold harmless BellSouth, each of its officers, directors and employees from and against any losses, damages, claims, demands, suits, liabilities, fines, penalties and expenses (including reasonable attorneys' fees) that arise out of or result from (i) any Environmental Hazard or Hazardous Materials that AT&T, its contractors or agents introduce to the Work Locations or (ii) the presence or Release of any Environmental Hazard or Hazardous Materials for which AT&T is responsible under Applicable Law, to the extent the release of any Environmental Hazard or Hazardous Materials is not caused or substantially contributed to by BellSouth's actions.
- 8.3 For purposes of this Section 8, the following terms shall have the following meaning:
- 8.3.1 "Environmental Hazard" means (1) a release, discharge, leak, spill or disposal (collectively referred to hereafter as "release") of HAZARDOUS MATERIALS has occurred on premises or property that is related to the performance of this Agreement and that such affected material or media is demonstrated through applicable or appropriate testing method to require remediation or removal as determined by all laws, ordinances, statutes, codes, rules, regulations, orders and decrees of the United States, the state, county, city or any other political subdivision in which the release has occurred, and any other

political subdivision, agency or instrumentality exercising jurisdiction over the release, including any applicable federal and state case law and common law interpreting any of the foregoing; or (2) any event involving, or exposure to, HAZARDOUS MATERIALS which poses risks to human health, safety or the environment (including, without limitation, indoor or outdoor environment(s) and is regulated under any applicable laws or regulations as described in (1);

- 8.3.2 "Hazardous Materials" means any hazardous or toxic substance, material or waste listed in the United States Department of Transportation HAZARDOUS MATERIALS Table at 49 CFR 172.101; any hazardous substance listed by the Environmental Protection Agency ("EPA") under the Comprehensive Environmental, Response, Compensation, and Liability Act ("CERCLA"), 42 U.S.C. §§ 9601, et seq., as amended, and found at 40 CFR Part 302; any hazardous waste listed under the Resource Conservation and Recovery Act ("RCRA"), 42 U.S.C. §§ 6901, et seq., as amended, and found at 40 CFR Part 261; any toxic substance regulated by the Toxic Substances Control Act, 15 U.S.C. §§ 2601, et seq., as amended; any insecticide, fungicide, or rodenticide regulated by the Federal Insecticide, Fungicide, and Rodenticide Act, 7 U.S.C. §§ 136, et seq.; and the following specified substances or materials, that may or may not be regulated by the above: (1) asbestos or asbestos-containing materials; (2) petroleum or petroleum-based or derived products or by-products; (3) polychlorinated biphenyls ("PCBs"); and (4) radon.
- 8.3.3 "Release" means any release, spill, emission, leaking, pumping, injection, deposit, disposal, discharge, dispersal, leaching, or migration, including without limitation, the movement of Environmental Hazards through or in the air, soil, surface water or groundwater, or any action or omission that causes Environmental Hazards to spread or become more toxic or more expensive to investigate or remediate.
- 8.3.4 "Waste" means all hazardous and non-hazardous substances and materials which are intended to be discarded, scrapped, or recycled, associated with activities AT&T or BellSouth or their respective contractors or agents perform at Work Locations. It shall be presumed that all substances or materials associated with such activities, that are not in use or incorporated into structures (including without limitation damaged components or tools, leftovers, containers, garbage, scrap, residues or byproducts), except for substances and materials that AT&T, BellSouth or their respective contractors or agents intend to use in their original form in connection with similar activities, are Waste. "Waste" shall not include substances, materials or components incorporated into structures (such as cable routes) even after such components or structure are no longer in current use.

9. Regulatory Matters

9.1 BellSouth shall be responsible for obtaining and keeping in effect all Federal Communications Commission, State Commissions, franchise authority and other regulatory approvals that may be required in connection with the performance of its obligations under this Agreement. AT&T shall be responsible for obtaining and keeping in effect all Federal Communications Commission, State Commission, franchise authority and other regulatory approvals that may be required in connection with its offering of services to AT&T end users contemplated by this Agreement. AT&T shall reasonably cooperate with BellSouth in obtaining and maintaining any required approvals for which BellSouth is responsible, and BellSouth shall reasonably cooperate with AT&T in obtaining and maintaining any required approvals for which AT&T is responsible.

9.2 In the event that BellSouth is required by any governmental authority to file a tariff or make another similar filing ("Filing") in order to implement this Agreement, BellSouth shall (i) consult with AT&T reasonably in advance of such Filing about the form and substance of such Filing, (ii) provide to AT&T its proposed tariff and obtain AT&T's agreement on the form and substance of such Filing, and (iii) take all steps reasonably necessary to ensure that such Filing imposes obligations upon BellSouth that are no less favorable than those provided in this Agreement and preserves for AT&T the full benefit of the rights otherwise provided in this Agreement. In no event shall BellSouth file any tariff to implement this Agreement that purports to govern Services and Elements that is inconsistent with the rates and other terms and conditions set forth in this Agreement unless such rate or other terms and conditions are more favorable than those set forth in this Agreement.

9.3 In the event that any final legislative, regulatory, judicial or other legal action materially affects any material terms of this Agreement, or the ability of AT&T or BellSouth to perform any material terms of this Agreement, AT&T or BellSouth may, on ninety (90) days' written notice (delivered not later than ninety (90) days following the date on which such action has become legally binding and has otherwise become final) require that such terms be renegotiated, and the Parties shall renegotiate in good faith such mutually acceptable new terms as may be required. In the event that such new terms are not renegotiated within ninety (90) days after such notice, the dispute shall follow the dispute resolution procedures set forth in Section 16 of the General Terms and Conditions of this Agreement.

10. Liability and Indemnity

- 10.1 Liabilities of BellSouth - Unless expressly stated otherwise in this Agreement, the financial liability of BellSouth to AT&T during any Contract Year resulting from any and all causes of action arising under this Agreement shall not exceed the amount due and owing by AT&T to BellSouth during the Contract Year in which such cause arises or accrues.
- 10.2 Liabilities of AT&T - Unless expressly stated otherwise in this Agreement, the financial liability of AT&T to BellSouth during any Contract Year resulting from any and all causes of action arising under this Agreement shall not exceed the amount due and owing by AT&T to BellSouth during the Contract Year in which such cause arises or accrues.
- 10.3 Each Party shall, to the greatest extent permitted by Applicable Law, include in its local switched service tariff (if it files one in a particular State) or in any State where it does not file a local service tariff, in an appropriate contract with its end users that relates to the Services and Elements provided under this Agreement, a limitation of liability (i) that covers the other Party to the same extent the first Party covers itself and (ii) that limits the amount of damages a customer may recover to the amount charged the applicable customer for the service that gave rise to such loss.
- 10.4 No Consequential Damages - NEITHER AT&T NOR BELLSOUTH SHALL BE LIABLE TO THE OTHER PARTY FOR ANY INDIRECT, INCIDENTAL, CONSEQUENTIAL, RELIANCE, OR SPECIAL DAMAGES SUFFERED BY SUCH OTHER PARTY (INCLUDING WITHOUT LIMITATION DAMAGES FOR HARM TO BUSINESS, LOST REVENUES, LOST SAVINGS, OR LOST PROFITS SUFFERED BY SUCH OTHER PARTIES), REGARDLESS OF THE FORM OF ACTION, WHETHER IN CONTRACT, WARRANTY, STRICT LIABILITY, OR TORT, INCLUDING WITHOUT LIMITATION NEGLIGENCE OF ANY KIND WHETHER ACTIVE OR PASSIVE, AND REGARDLESS OF WHETHER THE PARTIES KNEW OF THE POSSIBILITY THAT SUCH DAMAGES COULD RESULT. EACH PARTY HEREBY RELEASES THE OTHER PARTY AND SUCH OTHER PARTY'S SUBSIDIARIES AND AFFILIATES, AND THEIR RESPECTIVE OFFICERS, DIRECTORS, EMPLOYEES AND AGENTS FROM ANY SUCH CLAIM. NOTHING CONTAINED IN THIS SECTION 10 SHALL LIMIT BELLSOUTH'S OR AT&T'S LIABILITY TO THE OTHER FOR (i) WILLFUL OR INTENTIONAL MISCONDUCT (INCLUDING GROSS NEGLIGENCE); (ii) BODILY INJURY, DEATH OR DAMAGE TO TANGIBLE REAL OR TANGIBLE PERSONAL PROPERTY PROXIMATELY CAUSED BY BELLSOUTH'S OR AT&T'S NEGLIGENT ACT OR OMISSION OR THAT OF THEIR RESPECTIVE AGENTS, SUBCONTRACTORS OR EMPLOYEES, NOR SHALL ANYTHING CONTAINED IN THIS

SECTION 10 LIMIT THE PARTIES' INDEMNIFICATION OBLIGATIONS AS SPECIFIED HEREIN. FOR PURPOSES OF THIS SECTION 10, BELLSOUTH'S FAILURE TO MEET PERFORMANCE STANDARDS OR MEASUREMENTS PURSUANT TO ATTACHMENT 9 OF THIS AGREEMENT, TO THE EXTENT APPLICABLE, SHALL NOT BE CONSIDERED TO BE INDIRECT, INCIDENTAL, CONSEQUENTIAL, RELIANCE, OR SPECIAL DAMAGES.

- 10.5 Obligation to Indemnify – Except as provided in Section 11 (Intellectual Property Rights and Indemnification), each Party shall, and hereby agrees to, defend at the other's request, indemnify and hold harmless the other Party and each of its officers, directors, employees and agents (each, an "Indemnitee") against and in respect of any loss, debt, liability, damage, obligation, claim, demand, judgment or settlement of any nature or kind, known or unknown, liquidated or unliquidated, including without limitation all reasonable costs and expenses incurred (legal, accounting or otherwise) (collectively, "Damages") arising out of, resulting from or based upon any pending or threatened claim, action, proceeding or suit by any third Party (a "Claim") (i) alleging any breach of any representation, warranty or covenant made by such indemnifying Party (the "Indemnifying Party") in this Agreement, or (ii) based upon injuries or damage to any person or property or the environment arising out of or in connection with this Agreement that are the result of the Indemnifying Party's actions, breach of Applicable Law, or status of its employees, agents and subcontractors.
- 10.6 Obligation to Defend; Notice; Cooperation - Whenever a Claim shall arise for indemnification under this Section 10, the relevant Indemnitee, as appropriate, shall promptly notify the Indemnifying Party and request the Indemnifying Party to defend the same. Failure to so notify the Indemnifying Party shall not relieve the Indemnifying Party of any liability that the Indemnifying Party might have, except to the extent that such failure prejudices the Indemnifying Party's ability to defend such Claim. The Indemnifying Party shall have the right to defend against such liability or assertion in which event the Indemnifying Party shall give written notice to the Indemnitee of acceptance of the defense of such Claim and the identity of counsel selected by the Indemnifying Party. Except as set forth below, such notice to the relevant Indemnitee shall give the Indemnifying Party full authority to defend, adjust, compromise or settle such Claim with respect to which such notice shall have been given, except to the extent that any compromise or settlement shall prejudice the Intellectual Property Rights of the relevant Indemnitees. The Indemnifying Party shall consult with the relevant Indemnitee prior to any compromise or settlement that would affect the Intellectual Property Rights or other rights of any Indemnitee, and the relevant

Indemnitee shall have the right to refuse such compromise or settlement and, at the refusing Party's or refusing Parties' cost, to take over such defense, provided that in such event the Indemnifying Party shall not be responsible for, nor shall it be obligated to indemnify the relevant Indemnitee against, any cost or liability in excess of such refused compromise or settlement. With respect to any defense accepted by the Indemnifying Party, the relevant Indemnitee shall be entitled to participate with the Indemnifying Party in such defense if the Claim requests equitable relief or other relief that could affect the rights of the Indemnitee and also shall be entitled to employ separate counsel for such defense at such Indemnitee's expense. In the event the Indemnifying Party does not accept the defense of any indemnified Claim as provided above, the relevant Indemnitee shall have the right to employ counsel for such defense at the expense of the Indemnifying Party. Each Party agrees to cooperate and to cause its employees and agents to cooperate with the other Party in the defense of any such Claim and the relevant records of each Party shall be available to the other Party with respect to any such defense.

11. **Intellectual Property Rights and Indemnification**

- 11.1 Use of Mark. Both Parties are strictly prohibited from any use, including but not limited to in sales and in marketing or advertising of telecommunications services of any name, trade name, service mark or trademark of the other Party.
- 11.2 Ownership of Intellectual Property. Any intellectual property which originates from or is developed by a Party shall remain in the exclusive ownership of that Party. Except for limited licenses, to the extent necessary for the Parties to use any facilities or equipment (including software) or to receive any services solely as provided under this Agreement, no patent, copyright, trademark, trade name or other proprietary right is licensed, granted or otherwise transferred by this Agreement.
- 11.3 BellSouth and AT&T (if and to the extent BellSouth uses AT&T facilities or equipment, including software) warrants that each other may use any facilities or equipment, including software, provided hereunder that contains intellectual property owned or controlled by third parties without being subject to any claims of infringement by such third parties. Each Party further warrants that it will not enter into any licensing agreements with respect to any facilities or equipment, including software, that contain provisions that would disqualify the other Party from using or interconnecting with such facilities or equipment, including software, pursuant to the terms of this Agreement. Each Party further warrants that it has not and will not intentionally modify any existing license agreements for any network

facilities or equipment, including software, in whole or in part for the purpose of disqualifying the other Party from using or interconnecting with such facilities or equipment, including software, pursuant to the terms of this Agreement. To the extent that providers of facilities or equipment, including software, in either Party's network provide indemnities covering intellectual property liabilities and those indemnities allow a flow-through of protection to third parties, the indemnified party shall flow those indemnity protections through to the other Party. Finally each Party shall indemnify the other pursuant to the terms of this Agreement, with respect to the other Party's use of intellectual property associated with any new network facilities or equipment, including software, acquisitions.

- 11.4 BellSouth Indemnification. BellSouth will defend AT&T against claims of infringement arising solely from the use by AT&T of Services and Elements and will indemnify AT&T for any damages awarded based solely on such claims in accordance with Section 11 of this Agreement.
- 11.4.1 For purposes of Section 11.4 of this Agreement, BellSouth's obligation to indemnify AT&T shall include the obligation to indemnify and hold AT&T harmless from and against any loss, cost, expense or liability arising out of a claim that AT&T's use, pursuant to the terms of this Agreement, of BellSouth's facilities, equipment or software infringes the intellectual property rights of a third party. Should any such facilities, equipment or software, or any portion thereof, provided by BellSouth hereunder become, or, in BellSouth's reasonable opinion, be likely to become the subject of a claim of infringement, or should BellSouth's use thereof be finally enjoined, then BellSouth shall, at its expense, after consultation with AT&T, (i) procure for AT&T the right to continue using such facilities, equipment or software or portion thereof; or (ii) replace or modify such facilities, equipment or software or portion thereof to make it non-infringing, provided, however, that such replacement or modification shall be functionally equivalent to the facilities, equipment or software or portion thereof that is replaced or modified.
- 11.5 AT&T Indemnification. AT&T (if and only to the extent AT&T provides BellSouth access to its facilities and equipment, including software) will defend BellSouth against claims of infringement arising solely from the use by BellSouth of AT&T facilities or equipment, including software, and to the extent BellSouth uses AT&T facilities or equipment, including software, and will indemnify BellSouth for any damages awarded based solely on such claims in accordance with Section 11 of this Agreement.

- 11.5.1 For purposes of Section 11.5 of this Agreement, AT&T's obligation to indemnify BellSouth shall include the obligation to indemnify and hold BellSouth harmless from and against any loss, cost, expense or liability arising out of a claim that BellSouth's use, pursuant to the terms of this Agreement, of AT&T facilities or equipment, including software, infringes the intellectual property rights of a third party. Should any such facilities or equipment, including software, or any portion thereof, provided by AT&T hereunder become, or, in AT&T's reasonable opinion, be likely to become the subject of a claim of infringement, or should AT&T's use thereof be finally enjoined, then AT&T shall, at its expense, after consultation with BellSouth, (i) procure for BellSouth the right to continue using such facilities, equipment or software or portion thereof; or (ii) replace or modify such facilities, equipment or software or portion thereof to make it non-infringing, provided, however, that such replacement or modification shall be functionally equivalent to the facilities, equipment or software or portion thereof that is replaced or modified.
- 11.6 In the event that the provisions of Section 11.4.1 or Section 11.5.1 of this Agreement are unreasonable for the indemnifying party to perform, then the indemnified party shall have the right, in its sole discretion, to waive its indemnification rights under either Section 11.4 or Section 11.5 of this Agreement or to terminate the portion of the Agreement, upon thirty (30) days written notice, solely with respect to the facilities or equipment, including software, provided through the use of the infringing facilities or equipment, including software.
- 11.7 The Party providing access to its facilities or equipment, including software, will inform the other Party of any pending or threatened intellectual property claims of which it is aware and will provide to the other Party periodic and timely updates of such notification, as appropriate, so that the other Party receives maximum notice of any intellectual property risks that it may want to address.
- 11.8 In no event shall either Party be responsible for obtaining any license or right to use agreement associated with any facilities or equipment, including software, by either Party.
- 11.9 Exception to Obligations. Both Parties' obligations under this Section shall not apply to the extent the infringement is caused by: (i) modification of the facilities or equipment (including software) by the indemnitee; (ii) use by the indemnitee of the facilities or equipment (including software) in combination with equipment or facilities (including software) not provided or authorized by the indemnitor provided the facilities or equipment (including software) would not be infringing if used alone; (iii) conformance to specifications of the indemnitee which would necessarily result in infringement; or (iv)

continued use by the indemnitee of the affected facilities or equipment (including software) after being placed on notice to discontinue use as set forth herein.

11.10 Exclusive Remedy. The foregoing shall constitute the sole and exclusive remedies and obligations with respect to a third party claim of intellectual property infringement arising out of the conduct of business under this Agreement.

12. **Audits and Inspections**

12.1 For carrier billing purposes, the Parties have agreed pursuant to Section 12 of Attachment 6, to create a process for pre-bill certification. Until such time as that process is in place, the audit process provided in this Section 12 shall apply.

12.1.1 Subject to BellSouth's reasonable security requirements and except as may be otherwise specifically provided in this Agreement, AT&T may audit BellSouth's books, records and other documents once in each Contract Year for the purpose of evaluating the accuracy of BellSouth's billing and invoicing. AT&T may employ other persons or firms for this purpose. Such audit shall take place at a time and place agreed on by the Parties no later than thirty (30) days after notice thereof to BellSouth.

12.1.2 BellSouth shall promptly correct any billing error that is revealed in an audit, including making refund of any overpayment by AT&T in the form of a credit on the invoice for the first full billing cycle after the Parties have agreed upon the accuracy of the audit results. Any Disputes concerning audit results shall be resolved pursuant to the dispute resolution procedures described in Section 16 of the General Terms and Conditions of this Agreement.

12.1.3 BellSouth shall cooperate fully in any such audit, providing reasonable access to any and all appropriate BellSouth employees and books, records and other documents reasonably necessary to assess the accuracy of BellSouth's bills.

12.1.4 AT&T may audit BellSouth's books, records and documents more than once during any Contract Year if the previous audit found previously uncorrected net variances or errors in invoices in BellSouth's favor with an aggregate value of at least two percent (2%) of the amounts payable by AT&T for Services and Elements or Combinations provided during the period covered by the audit.

12.1.5 Audits shall be at AT&T's expense, subject to reimbursement by BellSouth in the event that an audit finds an adjustment in the charges

or in any invoice paid or payable by AT&T hereunder by an amount that is, on an annualized basis, greater than two percent (2%) of the aggregate charges for the Services and Elements during the period covered by the audit.

12.1.6 Upon (i) the discovery by BellSouth of overcharges not previously reimbursed to AT&T or (ii) the resolution of disputed audits, BellSouth shall promptly reimburse AT&T the amount of any overpayment times the highest interest rate (in decimal value) which may be levied by law for commercial transactions, compounded daily for the number of days from the date of overpayment to and including the date that payment is actually made. In no event, however, shall interest be assessed on any previously assessed or accrued late payment charges.

12.2 Subject to reasonable security requirements, either Party may audit the books, records and other documents of the other for the purpose of evaluating usage pertaining to transport and termination of local traffic. Where such usage data is being transmitted through CABS, the audit shall be conducted in accordance with CABS or other applicable requirements approved by the appropriate State Commission. If data is not being transferred via CABS, either Party may request an audit for such purpose once each Contract Year. Either Party may employ other persons or firms for this purpose. Any such audit shall take place no later than thirty (30) days after notice thereof to the other Party.

12.2.1 Either Party shall promptly correct any reported usage error that is revealed in an audit, including making payment of any underpayment after the Parties have agreed upon the accuracy of the audit results. Any Disputes concerning audit results shall be resolved pursuant to the dispute resolution procedures described in Section 16 of the General Terms and Conditions of this Agreement.

12.2.2 The Parties shall cooperate fully in any such audit, providing reasonable access to any and all appropriate employees and books, records and other documents reasonably necessary to assess the usage pertaining to transport and terminating of local traffic.

13. Service Quality Measurement

13.1 Service Quality Measurements shall be as set forth in Attachment 9, incorporated herein by this reference.

13.2 BellSouth shall provide telecommunications services pursuant to Attachment 1 to AT&T for resale that are equal in quality, subject to the same conditions, and provided within the same provisioning time

intervals that BellSouth provides these services to others, including end users.

13.3 BellSouth shall provide, for the facilities and equipment of AT&T, interconnection with BellSouth's network that is at a level of quality that is equal to that which BellSouth provides itself, a subsidiary, an affiliate, or any other third party.

13.4 To the extent technically feasible, the quality of a Network Element, as well as the quality of the access to such Network Element, provided to AT&T by BellSouth shall be at least equal in quality to that which BellSouth provides to itself.

14. Force Majeure

14.1 Neither Party shall be liable for any delay or failure in performance of any part of this Agreement caused by a Force Majeure condition, including acts of the United States of America or any state, territory or political subdivision thereof, acts of God or a public enemy, fires, floods, disputes, freight embargoes, strikes, labor disputes, earthquakes, volcanic actions, wars, civil disturbances, or other causes beyond the reasonable control of the Party claiming excusable delay or other failure to perform. Force Majeure shall not include acts of any Governmental Authority relating to environmental, health or safety conditions at Work Locations. If any Force Majeure condition occurs, the Party whose performance fails or is delayed because of such Force Majeure condition shall give prompt notice to the other Party, and upon cessation of such Force Majeure condition, shall give like notice and commence performance hereunder as promptly as reasonably practicable.

14.2 Notwithstanding Section 14.1 of this Agreement, no delay or other failure to perform shall be excused pursuant to this Section 14 by the acts or omission of a Party's subcontractors, material persons, suppliers or other third persons providing products or services to such Party unless: (i) there is a Force Majeure condition that affects the performance of said subcontractors, material persons, suppliers or other third persons, (ii) such acts or omissions do not relate to environmental, health or safety conditions at Work Locations and, (iii) unless such delay or failure and the consequences thereof are beyond the control and without the fault or negligence of the Party claiming excusable delay or other failure to perform. Notwithstanding the foregoing, this Section 14 shall not excuse failure or delays where either Party is required to implement Disaster Recovery plans to avoid such failures and delays in performance.

15. Certain Federal, State and Local Taxes

- 15.1 Definition. For purposes of this Section 15, the terms “taxes” and “fees” shall include but not be limited to federal, state or local sales, use, excise, gross receipts or other taxes or tax-like fees of whatever nature and however designated (including tariff surcharges and any fees, charges or other payments, contractual or otherwise, for the use of public streets or rights of way, whether designated as franchise fees or otherwise) imposed on, or sought to be imposed, either of the Parties and measured by the charges or payments, for the services furnished hereunder, excluding any taxes levied on income.
- 15.2 Taxes And Fees Imposed Directly On Either Seller Or Purchaser
- 15.2.1 Taxes and fees imposed on the providing Party, which are neither permitted nor required to be passed on by the providing Party to its Customer, shall be borne and paid by the providing Party.
- 15.2.2 Taxes and fees imposed on the purchasing Party, which are not required to be collected and/or remitted by the providing Party, shall be borne and paid by the purchasing Party.
- 15.3 Taxes And Fees Imposed On Purchaser But Collected And Remitted By Seller
- 15.3.1 Taxes and fees imposed on the purchasing Party shall be borne by the purchasing Party, even if the obligation to collect and/or remit such taxes or fees is placed on the providing Party.
- 15.3.2 To the extent permitted by Applicable Law, any such taxes and/or fees shall be shown as separate items on applicable billing documents between the Parties. Notwithstanding the foregoing, the purchasing Party shall remain liable, to the extent permitted by Applicable law, for any such taxes and fees regardless of whether they are actually billed by the providing Party at the time that the respective service is billed.
- 15.3.3 If the purchasing Party determines that in its opinion any such taxes or fees are not lawfully due, the providing Party shall not bill such taxes or fees to the purchasing Party if the purchasing Party provides written certification, reasonably satisfactory to the providing Party, stating that it is exempt or otherwise not subject to the tax or fee, setting forth the basis therefor, and satisfying any other requirements under Applicable Law. If any authority seeks to collect any such tax or fee that the purchasing Party has determined and certified not to be lawfully due, or any such tax or fee that was not billed by the providing Party, the purchasing Party may contest the same in good faith, at its own expense. In the event that such contest must be pursued in the name of the providing Party, the providing Party shall permit the purchasing Party to pursue and control the contest in the name of providing Party

and providing Party shall have the opportunity to participate fully in the preparation of such contest. In any such contest, the purchasing Party shall promptly furnish the providing Party with copies of all filings in any proceeding, protest, or legal challenge, all rulings issued in connection therewith, and all correspondence between the purchasing Party and the taxing authority.

- 15.3.4 In the event that all or any portion of an amount sought to be collected must be paid in order to contest the imposition of any such tax or fee, or to avoid the existence of a lien on the assets of the providing Party during the pendency or such contest, the purchasing Party shall be responsible for such payment and shall be entitled to the benefit of any refund or recovery.
- 15.3.5 If it is ultimately determined that any additional amount of such a tax or fee is due to the imposing authority, the purchasing Party shall pay such additional amount, including any interest and penalties thereon.
- 15.3.6 Notwithstanding any provision to the contrary, the purchasing Party shall protect, indemnify and hold harmless (and defend at the purchasing Party's expense) the providing Party from and against any such tax or fee, interest or penalties thereof, or other charges or payable expenses (including reasonable attorney fees) with respect thereto, which are reasonably and necessarily incurred by the providing Party in connection with any claim for or contest of any such tax or fee.
- 15.3.7 Each Party shall notify the other Party in writing of any assessment, proposed assessment or other claim for any additional amount of such a tax or fee by a taxing authority; such notice to be provided, if possible, at least ten (10) days prior to the date by which a response, protest or other appeal must be filed, but in no event later than thirty (30) days after receipt of such assessment, proposed assessment or claim.
- 15.4 Taxes And Fees Imposed On Seller But Passed On To Purchaser
- 15.4.1 Taxes and fees imposed on the providing Party, which are permitted or required to be passed on by the providing Party to its Customer, shall be borne by the purchasing Party.
- 15.4.2 To the extent permitted by Applicable Law, any such taxes and/or fees shall be shown as separate items on applicable billing documents between the Parties. Notwithstanding the foregoing, to the extent permitted by Section 15 with respect to the billing of services provided hereunder, the purchasing Party shall remain liable for any such taxes

and fees regardless of whether they are actually billed by the providing Party at the time that the respective service is billed.

- 15.4.3 If the purchasing Party disagrees with the providing Party's determination as to the application or basis for any such tax or fee, the Parties shall consult with respect to the imposition and billing of such tax or fee and with respect to whether to contest the imposition of such tax or fee. Notwithstanding the foregoing, the providing Party shall retain responsibility for determining whether and to what extent any such taxes or fees are applicable. The providing Party shall further retain responsibility for determining whether and how to contest the imposition of such taxes or fees, provided, however, the Parties agree to consult in good faith as to such contest and that any such contest undertaken at the request of the purchasing Party shall be at the purchasing Party's expense. In the event that such contest must be pursued in the name of the providing Party, providing Party shall permit purchasing Party to pursue the contest in the name of the providing Party and the providing Party shall have the opportunity to participate fully in the preparation of such contest.
- 15.4.4 If, after consultation in accordance with the preceding Section 15.4.3, the purchasing Party does not agree with the providing Party's final determination as to the application or basis of a particular tax or fee, and if the providing Party, after receipt of a written request by the purchasing Party to contest the imposition of such tax or fee with the imposing authority, fails or refuses to pursue such contest or to allow such contest by the purchasing Party, the purchasing Party may utilize the dispute resolution process outlined in Section 16 of the General Terms and Conditions of this Agreement. Utilization of the dispute resolution process shall not relieve the purchasing party from liability for any tax or fee billed by the providing Party pursuant to this subsection during the pendency of such dispute resolution proceeding. In the event that the purchasing Party prevails in such dispute resolution proceeding, it shall be entitled to a refund in accordance with the final decision therein. Notwithstanding the foregoing, if at any time prior to a final decision in such dispute resolution proceeding the providing Party initiates a contest with the imposing authority with respect to any of the issues involved in such dispute resolution proceeding, the dispute resolution proceeding shall be dismissed as to such common issues and the final decision rendered in the contest with the imposing authority shall control as to such issues.
- 15.4.5 In the event that all or any portion of an amount sought to be collected must be paid in order to contest the imposition of any such tax or fee with the imposing authority, or to avoid the existence of a lien on the assets of the providing Party during the pendency of such contest, the

purchasing Party shall be responsible for such payment and shall be entitled to the benefit of any refund or recovery

15.4.6 If it is ultimately determined that any additional amount of such a tax or fee is due to the imposing authority, the purchasing Party shall pay such additional amount, including any interest and penalties thereon.

15.4.7 Notwithstanding any provision to the contrary, the purchasing Party shall protect, indemnify and hold harmless (and defend at the purchasing Party's expense) the providing Party from and against any such tax or fee, interest or penalties thereon, or other reasonable charges or payable expenses (including reasonable attorney fees) with respect thereto, which are incurred by the providing Party in connection with any claim for or contest of any such tax or fee which purchasing party elects to contest or which purchasing party provides written authorization for the providing party to undertake on behalf of the purchasing party.

15.4.8 Each Party shall notify the other Party in writing of any assessment, proposed assessment or other claim for any additional amount of such a tax or fee by a taxing authority, such notice to be provided, if possible, at least ten (10) days prior to the date by which a response, protest or other appeal must be filed, but in no event later than thirty (30) days after receipt of such assessment, proposed assessment or claim.

15.5 Mutual Cooperation

15.5.1 In any contest of a tax or fee by one Party, the other Party shall cooperate fully by providing records, testimony and such additional information or assistance as may reasonably be necessary to pursue the contest. Further, the other Party shall be reimbursed for any reasonable and necessary out-of-pocket copying and travel expenses incurred in assisting in such contest. Each Party agrees to indemnify and hold harmless the other Party from and against any losses, damages, claims, demands, suits, liabilities, and expenses, including reasonable attorney's fees, that arise out of its failure to perform its obligations under this section.

16. **Dispute Resolution Process**

Except as otherwise stated in this Agreement, i.e. the process for resolving billing disputes as described in Attachment 6, Section 1.15, the Parties agree that any other dispute that arises as to the interpretation of any provision of this Agreement or as to the proper implementation of this Agreement, may be taken to the Commission for resolution. The Parties may, by mutual agreement, agree to an

alternative dispute resolution mechanism for any dispute, except billing disputes shall be resolved as described in Attachment 6, Section 1.15. Each Party reserves the rights it may have to seek judicial review of any ruling made by the Commission concerning this Agreement.

17. **Notices**

17.1 Any notices or other communications required or permitted to be given or delivered under this Agreement shall be in hard-copy writing (unless otherwise specifically provided herein) and shall be sufficiently given if delivered personally or delivered by prepaid overnight express service to the following (unless otherwise specifically required by this Agreement to be delivered to another representative or point of contact):

If to AT&T:

Bill Peacock
AT&T
1200 Peachtree St., N.E.
Suite 12254
Atlanta, GA 30309

Chief Commercial Attorney
AT&T
Legal Department
1200 Peachtree St., N.E.
Suite 8100
Atlanta, GA 30309

If to BellSouth:

Assistant Vice President
AT&T Account Team
Interconnection Services
Suite 410
1960 W. Exchange Place
Tucker, GA 30064

General Attorney-Commercial Unit
BellSouth
Legal Department
675 W. Peachtree St., Suite 4300
Atlanta, GA 30375

17.2 Either Party may unilaterally change its designated representative and/or address for the receipt of notices by giving seven (7) days prior

written notice to the other Party in compliance with this Section. Any notice or other communication shall be deemed given when received.

18. Confidentiality and Proprietary Information

18.1 For the purposes of this Agreement, "Confidential Information" means confidential or proprietary technical or business Information given by one Party (the "Discloser") to the other Party (the "Recipient") and identified by the Discloser as Confidential Information in accordance with this Section. All information which is to be treated as Confidential Information under this Agreement shall:

18.1.1 If in written, graphic, electromagnetic, or other tangible form, be marked as "Confidential Information"; and

18.1.2 If oral, (i) be identified by the Discloser at the time of disclosure to be "Confidential Information", and (ii) be set forth in a written summary which identifies the information as "Confidential Information" and which is delivered by the Discloser to the Recipient within ten (10) days after the oral disclosure.

18.1.3 Each Party shall have the right to correct an inadvertent failure to identify information as Confidential Information by giving written notification within thirty (30) days after the information is disclosed. The Recipient shall, from that time forward, treat such information as Confidential Information.

18.2 In addition to any requirements imposed by 47 U.S.C. § 222, for a period of five (5) years from the receipt of Confidential Information from the Discloser, except as otherwise specified in this Agreement, the Recipient agrees (a) to use it only for the purpose of performing under this Agreement, (b) to hold it in confidence and disclose it to no one other than its employees having a need to know for the purpose of performing under this Agreement, and (c) to safeguard it from unauthorized use or disclosure with at least the same degree of care with which the Recipient safeguards its own Confidential Information. If the Recipient wishes to disclose the Discloser's Confidential Information to a third Party agent or consultant, the agent or consultant must have executed a written agreement of non-disclosure and non-use comparable in scope to the terms of this Section.

18.3 The Recipient may make copies of Confidential Information only as reasonably necessary to perform its obligations under this Agreement. All such copies shall bear the same copyright and proprietary rights notices as are contained on the original.

- 18.4 The Recipient agrees to return all Confidential Information in tangible form received from the Discloser, including any copies made by the Recipient, within thirty (30) days after a written request is delivered to the Recipient, or to destroy all such Confidential Information, except for Confidential Information that the Recipient reasonably requires to perform its obligations under this Agreement. If either Party loses or makes an unauthorized disclosure of the other Party's Confidential Information, it shall notify such other Party immediately and use reasonable efforts to retrieve the lost or wrongfully disclosed information.
- 18.5 The Recipient shall have no obligation to safeguard Confidential Information: (a) which was in the possession of the Recipient free of restriction prior to its receipt from the Discloser; (b) after it becomes publicly known or available through no breach of this Agreement by the Recipient; (c) after it is rightfully acquired by the Recipient free of restrictions on its disclosure; or (d) after it is independently developed by personnel of the Recipient to whom the Discloser's Confidential Information had not been previously disclosed. In addition, either Party shall have the right to disclose Confidential Information to any mediator, arbitrator, state or federal regulatory body, the Department of Justice or any court in the conduct of any mediation, arbitration or approval of this Agreement or in any proceedings concerning the provision of interLATA services by BellSouth that are or may be required by the Act. Additionally, the Recipient may disclose Confidential Information if so required by law, a court, or governmental agency, so long as the Discloser has been notified of the requirement promptly after the Recipient becomes aware of the requirement. In all cases, the Recipient must undertake all lawful measures to avoid disclosing such information until Discloser has had reasonable time to seek and comply with a protective order that covers the Confidential Information to be disclosed.
- 18.6 Each Party's obligations to safeguard Confidential Information disclosed prior to expiration or termination of this Agreement shall survive such expiration or termination.
- 18.7 Except as otherwise expressly provided elsewhere in this Agreement, no license is hereby granted under any patent, trademark, or copyright, nor is any such license implied, solely by virtue of the disclosure of any Confidential Information.
- 18.8 Each Party agrees that the Discloser would be irreparably injured by a breach of this Agreement by the Recipient or its representatives and that the Discloser shall be entitled to seek equitable relief, including injunctive relief and specific performance, in the event of any breach of the provisions of this Agreement. Such remedies shall not be deemed

to be the exclusive remedies for a breach of this Agreement, but shall be in addition to all other remedies available at law or in equity.

19. Branding

19.1 AT&T shall provide the exclusive interface to AT&T end users, except as AT&T shall otherwise specify. In those instances where AT&T requires BellSouth personnel or systems to interface with AT&T end users, such personnel shall identify themselves as representing AT&T, and shall not identify themselves as representing BellSouth. Except for material provided by AT&T, all forms, business cards or other business materials furnished by BellSouth to AT&T end users shall be subject to AT&T's prior review and approval. In no event shall BellSouth, acting on behalf of AT&T pursuant to this Agreement, provide information to AT&T local service Customers about BellSouth products or services. BellSouth agrees to provide in sufficient time for AT&T to review and provide comments, the methods and procedures, training and approaches, to be used by BellSouth to assure that BellSouth meets AT&T's branding requirement. For installation and repair services, AT&T agrees to provide BellSouth with branded material at no charge for use by BellSouth ("Leave Behind Material"). AT&T will reimburse BellSouth for the reasonable and demonstrable costs BellSouth would otherwise incur as a result of the use of the generic leave behind material. BellSouth will notify AT&T of material supply exhaust in sufficient time that material will always be available. BellSouth will not be liable for any error, mistake or omission, other than intentional acts or omissions or gross negligence, resulting from the requirements to distribute AT&T's Leave Behind Material.

20. Directory Listings Requirements

20.1 BellSouth shall make available to AT&T, for AT&T subscribers, non discriminatory access to its telephone number and address directory listings ("Directory Listings"), under the following terms and conditions. In no event shall AT&T subscribers receive Directory Listings that are at less favorable rates, terms or conditions than the rates, terms or conditions that BellSouth provides its subscribers.

20.1.1 BellSouth has delegated certain authority to its affiliate, BellSouth Advertising & Publishing Corporation ("BAPCO"), and has required BAPCO to carry out certain BellSouth obligations imposed by the Act regarding the publication of directories. AT&T and BAPCO have entered into an agreement, which is appended as Attachment 13 to this Agreement and incorporated herein by this reference, regarding BAPCO's treatment of AT&T's end users' directory listing information in directories published by BAPCO. BellSouth shall maintain the Directory Listings database, which includes AT&T's end users'

directory listing information, used by BAPCO in publishing such directories in accordance with Section 20.2.1 below. Subject to execution of such agreement between AT&T and BAPCO, BAPCO shall publish directory listings as follows:

- 20.1.1.1 White Pages Basic Directory Listings. BellSouth shall publish in all BellSouth's white pages Directories at no charge to AT&T or any AT&T Customer one white pages basic Directory Listing for each AT&T Customer for all of such Customer's phone numbers located in the geographic region covered by any white pages Directory. Notwithstanding the foregoing, BellSouth shall not publish any white pages basic Directory Listing for any AT&T Customer whose Directory Listing has been identified as non-published. AT&T will be required to provide to BellSouth the names, addresses and telephone numbers of all AT&T end users that wish to be omitted from directories.
- 20.1.1.2 Enhanced White Pages Listings. Where BellSouth offers to publish, at no charge, in its white pages directory Enhanced White Pages Listings to its retail customers, BellSouth shall publish such listings, at no charge and under the same terms and conditions, for AT&T for its end users. Where BellSouth charges its retail customers for Enhanced White Pages Listings, BellSouth shall publish such listings under the same terms and conditions to AT&T for its Customers at the applicable wholesale discount set forth in Attachment 1.
- 20.1.1.3 Yellow Pages Basic Directory Listings. Where BellSouth offers to publish in its Yellow Pages Directory free Yellow Pages listings to its retail end users, BellSouth shall publish such listings, at no charge and under the same terms and conditions to AT&T for its end users. Where BellSouth charges business customers for Yellow Pages basic Directory Listings, BellSouth shall provide one Yellow Pages basic Directory Listing for each AT&T end user, who subscribes to business services, at BellSouth tariffed rates at the applicable wholesale discount set forth in Attachment 1. BellSouth shall not provide "lead" information on AT&T end users to its Yellow Pages directory publishing Affiliate without written permission from AT&T.
- 20.1.2 Treatment of Directory Listings. BellSouth shall treat all Directory Listings with the same level of confidentiality that BellSouth accords its own directory listing information, and BellSouth shall limit access to AT&T's end user proprietary confidential directory information to those BellSouth employees who are involved in the preparation of listings. Directory Listings of AT&T Customers shall be alphabetically commingled with the Directory Listings of all other telecommunications carriers, including BellSouth. All Directory Listings published by BellSouth will be as accurate and complete as BellSouth's own listings or those of its Affiliates.

20.1.3 Reserved Rights. AT&T reserves the right to withhold Directory Listing information from BellSouth if BellSouth charges AT&T a rate for inclusion of AT&T's unlisted numbers in the BellSouth directory databases exceeding the BellSouth retail tariffed charge for unlisted numbers.

20.2 Directory Listings Database

20.2.1 Maintenance. BellSouth shall maintain a Directory Listings database that shall include the directory listings of BellSouth, AT&T and any other carrier for whom BellSouth has agreed to publish Directory Listings. AT&T and BellSouth shall cooperate to ensure that Directory Listing information relating to AT&T end user is delivered to BellSouth and reflected in such database in a timely and accurate manner (and in no event in a manner that is less timely or accurate than the manner in which BellSouth's Directory Listings database is updated for information relating to BellSouth's end user). Data should be generated from the local service order process and other data feeds for facility-based carriers and should be subject to the same rigorous edits that are applied to BellSouth local service orders. BellSouth shall use all commercially reasonable efforts to maintain the Directory Listings database in good order. BellSouth shall advise AT&T as soon as possible, but in no event fewer than six (6) months in advance, of any changes in the maintenance of the Directory Listings database or any mechanisms or interfaces, whether industry standard or not, pursuant to which BellSouth will provide Directory Listings to AT&T.

20.2.2 Third Party Access to Directory Listings Database. AT&T authorizes BellSouth to provide Directory Listings of AT&T end user to third parties on terms and conditions that comport with the Communications Act and the relevant FCC rules and orders and on the same terms and conditions applicable to the release of Directory Listings of BellSouth end users to third parties. This data shall not be used for any other purpose than publishing a directory.

20.2.3 Co-operation. AT&T and BellSouth agree to co-operate in good faith to resolve any issue regarding a Directory Listing raised by an AT&T end user (e.g., publication of a nonpublished Directory Listing, etc.) Upon request by either party, AT&T and BellSouth will in good faith mutually develop a process for escalating and resolving such issues.

21. Insurance Requirements

21.1 At all times during the term of this Agreement, each Party shall maintain, at its own expense, (i) all insurance required by applicable Law including insurance and approved self insurance for statutory workers compensation coverage and (ii) commercial general liability

coverage in the amount of not less than ten million dollars (\$10,000,000) or a combination of commercial general liability and excess/umbrella coverage totaling ten million dollars (\$10,000,000). Upon request from the other Party, each Party shall furnish the other Party with certificates of insurance which evidence the minimum levels of insurance set forth herein. Each Party may satisfy all or part of the coverage specified herein through self insurance. Each Party shall give the other Party at least thirty (30) days advance written notice of any cancellation or non-renewal of insurance required by this Section.

22. Costs

22.1 Except as otherwise specified in this Agreement, the Act, or any Commission order, each Party shall be responsible for all costs and expenses that it incurs to comply with its obligations under this Agreement.

23. Disaster Recovery

23.1 The Party's Disaster Recovery Plan is as set forth in Exhibit A of this Agreement.

24. Miscellaneous

24.1 Delegation or Assignment

24.1.1 BellSouth may not assign any of its rights or delegate any of its obligations under this Agreement without the prior written consent of AT&T which will not be unreasonably withheld. Notwithstanding the foregoing, BellSouth may assign its rights and benefits and delegate its duties and obligations under this Agreement without the consent of AT&T to a 100 percent owned Affiliate company of BellSouth if such Affiliate provides wireline communications, provided that the performance of any such assignee is guaranteed by the assignor. Any prohibited assignment or delegations shall be null and void. In no event shall BellSouth require that this Agreement be assigned to an Affiliate to AT&T in order for such Affiliate to order Interconnection, Network Elements or services hereunder.

24.1.2 Transfer of Exchanges

If BellSouth wishes to sell, exchange, or otherwise transfer ownership of any exchange in a portion of Kentucky served by BellSouth as an incumbent local exchange carrier ("Transfer") to a third party, BellSouth shall first provide written notice to AT&T.

24.2 **Subcontracting**

24.2.1 If any Party's obligation under this Agreement is performed by a subcontractor or Affiliate, the Party subcontracting the obligation nevertheless shall remain fully responsible for the performance of this Agreement in accordance with its terms, and shall be solely responsible for payments due its subcontractors or Affiliate. In entering into any contract, subcontract or other agreement for the performance of any obligation under this Agreement, the Party shall not enter into any agreement that it would not enter into if the supplier was performing services directly for said Party.

24.3 **Nonexclusive Remedies**

24.3.1 Except as otherwise expressly provided in this Agreement, each of the remedies provided under this Agreement is cumulative and is in addition to any remedies that may be available at law or in equity.

24.4 **No Third-Party Beneficiaries**

24.4.1 Except as may be specifically set forth in this Agreement, this Agreement does not provide and shall not be construed to provide third Parties with any remedy, claim, liability, reimbursement, cause of action, or other privilege.

24.5 **Referenced Documents**

24.5.1 Whenever any provision of this Agreement refers to a technical reference, technical publication, AT&T Practice, BellSouth Practice, any publication of telecommunications industry administrative or technical standards, or any other document specifically incorporated into this Agreement, it will be deemed to be a reference to the most recent version or edition (including any amendments, supplements, addenda, or successors) of such document that is in effect, and will include the most recent version or edition (including any amendments, supplements, addenda, or successors) of each document incorporated by reference in such a technical reference, technical publication, AT&T Practice, BellSouth Practice, or publication of industry standards (unless AT&T elects otherwise). Should there be an inconsistency between or among publications or standards, the Parties shall mutually agree upon which requirement shall apply. If the Parties cannot reach agreement, the matter shall be handled pursuant to Section 16 of the General Terms and Conditions of this Agreement.

24.6 **Applicable Law**

24.6.1 The validity of this Agreement, the construction and enforcement of its terms, and the interpretation of the rights and duties of the Parties shall be governed by the laws of the State of Georgia other than as to

conflicts of laws, except insofar as federal law may control any aspect of this Agreement, in which case federal law shall govern such aspect. The Parties submit to personal jurisdiction in Atlanta, Georgia, and waive any objections to a Georgia venue.

24.7 Amendments or Waivers

24.7.1 Except as otherwise provided in this Agreement, no amendment or waiver of any provision of this Agreement, and no consent to any default under this Agreement, shall be effective unless the same is in writing and signed by an officer of the Party against whom such amendment, waiver or consent is claimed. In addition, no course of dealing or failure of a Party strictly to enforce any term, right or condition of this Agreement shall be construed as a waiver of such term, right or condition. By entering into this Agreement, neither Party waives any rights granted to them pursuant to the Act.

24.8 Severability

24.8.1 If any term, condition or provision of this Agreement is held to be invalid or unenforceable for any reason, such invalidity or unenforceability shall not invalidate the entire Agreement, unless such construction would be unreasonable. The Agreement shall be construed as if it did not contain the invalid or unenforceable provision or provisions, and the rights and obligations of each Party shall be construed and enforced accordingly; provided, however, that in the event such invalid or unenforceable provision or provisions are essential elements of this Agreement and substantially impair the rights or obligations of either Party, the Parties shall promptly negotiate a replacement provision or provisions.

24.9 Entire Agreement

24.9.1 This Agreement, which shall include the Attachments, Appendices and other documents referenced herein, constitutes the entire Agreement between the Parties concerning the subject matter hereof and supersedes any prior agreements, representations, statements, negotiations, understandings, proposals or undertakings, oral or written, with respect to the subject matter expressly set forth herein.

24.10 Survival of Obligations

24.10.1 Any liabilities or obligations of a Party for acts or omissions prior to the cancellation or termination of this Agreement, any obligation of a Party under the provisions regarding indemnification, Confidential Information, limitations on liability, and any other provisions of this Agreement which, by their terms, are contemplated to survive (or to be

performed after) termination of this Agreement, shall survive cancellation or termination thereof.

24.11 Executed in Counterparts

24.11.1 This Agreement may be executed in any number of counterparts, each of which shall be deemed an original, but such counterparts shall together constitute one and the same instrument.

24.12 Headings of No Force or Effect

24.12.1 The headings of Articles and Sections of this Agreement are for convenience of reference only, and shall in no way define, modify or restrict the meaning or interpretation of the terms or provisions of this Agreement.

24.13 Notice of Network Changes

24.13.1 BellSouth shall comply with the requirements of 47 C.F.R. § 51.325, et seq., regarding notice to AT&T of any network change that will affect AT&T's performance or ability to provide service or that will affect BellSouth's interoperability with AT&T. This section shall be construed in accordance with the obligations contained within 47 C.F.R. § 51.325, et seq.

24.14 Court Ordered Requests for Call Detail Records and Other Subscriber Information

24.14.1 To the extent technically feasible, BellSouth maintains call detail records for AT&T end users for limited time periods and can respond to subpoenas and court ordered requests for this information. BellSouth shall maintain such information for AT&T end users for the same length of time it maintains such information for its own end users.

24.14.2 AT&T agrees that BellSouth will respond to subpoenas and court ordered requests delivered directly to BellSouth for the purpose of providing call detail records when the targeted telephone numbers belong to AT&T end users. Billing for such requests will be generated by BellSouth and directed to the law enforcement agency initiating the request.

24.14.3 Where BellSouth is providing to AT&T telecommunications services for resale or providing to AT&T the local switching function, then AT&T agrees that in those cases where AT&T receives subpoenas or court ordered requests regarding targeted telephone numbers belonging to AT&T end users, if AT&T does not have the requested information, AT&T will advise the law enforcement agency initiating the request to

redirect the subpoena or court ordered request to BellSouth. Where the request has been forwarded to BellSouth, billing for call detail information will be generated by BellSouth and directed to the law enforcement agency initiating the request.

- 24.14.4 In all other instances, AT&T will provide AT&T end user and/or other customer information that is available to AT&T in response to subpoenas and court orders for their own end user records. When BellSouth receives subpoenas or court ordered requests regarding targeted telephone numbers belonging to AT&T end users, BellSouth will advise the law enforcement agency initiating the request to redirect the subpoena or court ordered request to AT&T.

24.15 Filing of Agreement

- 24.15.1 Upon execution of this Agreement, it shall be filed with the appropriate state regulatory agency pursuant to the requirements of Section 252 of the Act.

24.16 Other Proceedings

- 24.16.1 Upon written request by AT&T, BellSouth agrees to negotiate rates, (if appropriate), terms and conditions to incorporate into this Agreement any obligation or commitment regarding interconnection, resale or access to Network Elements made by BellSouth to any state or federal regulatory authority or the U.S. Department of Justice ("Governmental Body") in connection with any merger or regulatory proceeding regarding BellSouth's obligations under the Act, including 47 U.S.C. § 271 thereunder. If the Parties cannot reach an agreement regarding the rates, terms and conditions, either Party may, within sixty (60) days after receipt of the request from AT&T, petition the state regulatory commission for resolution of the issue(s). The language to be negotiated and incorporated within this Agreement will be effective consistent with the effective date of the commitment or obligation made by BellSouth to the Governmental Body. AT&T's rights pursuant to this Section shall be cumulative with, and not in lieu of or in limitation of, any other rights provided to AT&T under this Agreement.

25. Reservation of Rights

- 25.1 Execution of the Interconnection Agreement by either Party does not confirm or infer that the executing Party agrees with any decision(s) issued pursuant to the Telecommunications Act of 1996 and the consequences of those decisions on specific language in this Agreement. Neither Party waives its rights to appeal or otherwise challenge any such decision(s) and each Party reserves all of its rights to pursue any and all legal and/or equitable remedies, including appeals of any such decision(s). If such appeals or challenges result

in changes in the decision(s), the Parties agree that appropriate modifications to this Agreement will be made promptly to make its terms consistent with those changed decision(s).

IN WITNESS WHEREOF, the Parties have executed this Agreement through their authorized representatives.

AT&T COMMUNICATIONS OF
THE SOUTH CENTRAL STATES, INC.

BELLSOUTH
TELECOMMUNICATIONS, INC.

By: _____
Gregory P. Terry
Vice President
Local Services and
Access Management

By: _____
Jerry D. Hendrix
Exec.Sr. Director
Wholesale Pricing Operations

Date:_____

Date:_____

EXHIBIT A
BellSouth Disaster Recovery Plan

CONTENTS

	<u>PAGE</u>
1.0 Purpose	4
2.0 Single Point of Contact	4
3.0 Identifying the Problem	4
3.1 Site Control	5
3.2 Environmental Concerns	6
4.0 The Emergency Control Center (ECC)	6
5.0 Recovery Procedures	7
5.1 CLEC Outage	7
5.2 BellSouth Outage	7
5.2.1 Loss of Central Office	8
5.2.2 Loss of a Central Office with Serving Wire Center Functions	8
5.2.3 Loss of a Central Office with Tandem Functions	8
5.2.4 Loss of a Facility Hub	9
5.3 Combined Outage (CLEC and BellSouth Equipment)	9
6.0 T1 Identification Procedures	9
7.0 Acronyms	10

1.0 PURPOSE

In the unlikely event of a disaster occurring that affects BellSouth's long-term ability to deliver traffic to a Competitive Local Exchange Carrier (CLEC), general procedures have been developed to hasten the recovery process. Since each location is different and could be affected by an assortment of potential problems, a detailed recovery plan is impractical. However, in the process of reviewing recovery activities for specific locations, some basic procedures emerge that appear to be common in most cases.

These general procedures should apply to any disaster that affects the delivery of traffic for an extended time period. Each CLEC will be given the same consideration during an outage and service will be restored as quickly as possible.

This document will cover the basic recovery procedures that would apply to every CLEC.

2.0 SINGLE POINT OF CONTACT

When a problem is experienced, regardless of the severity, the BellSouth Network Management Center (NMC) will observe traffic anomalies and begin monitoring the situation. Controls will be appropriately applied to insure the sanity of BellSouth's network; and, in the event that a switch or facility node is lost, the NMC will attempt to circumvent the failure using available reroutes.

BellSouth's NMC will remain in control of the restoration efforts until the problem has been identified as being a long-term outage. At that time, the NMC will contact BellSouth's Emergency Control Center (ECC) and relinquish control of the recovery efforts. Even though the ECC may take charge of the situation, the NMC will continue to monitor the circumstances and restore traffic as soon as damaged network elements are revitalized.

The telephone number for the BellSouth Network Management Center in Atlanta, as published in Telcordia's National Network Management Directory, is 404-321-2516.

3.0 IDENTIFYING THE PROBLEM

During the early stages of problem detection, the NMC will be able to tell which CLECs are affected by the catastrophe. Further analysis and/or first hand observation will determine if the disaster has affected CLEC equipment only; BellSouth equipment only or a combination. The initial restoration activity will be largely determined by the equipment that is affected.

Once the nature of the disaster is determined and after verifying the cause of the problem, the NMC will initiate reroutes and/or transfers that are jointly agreed upon by the affected CLECs' Network Management Center and the BellSouth NMC. The type and percentage of controls used will depend upon available network capacity. Controls necessary to stabilize the situation will be invoked and the NMC will attempt to re-establish as much traffic as possible.

For long term outages, recovery efforts will be coordinated by the Emergency Control Center (ECC). Traffic controls will continue to be applied by the NMC until facilities are re-established.

As equipment is made available for service, the ECC will instruct the NMC to begin removing the controls and allow traffic to resume.

3.1 SITE CONTROL

In the total loss of building use scenario, what likely exists will be a smoking pile of rubble. This rubble will contain many components that could be dangerous. It could also contain any personnel on the premises at the time of the disaster. For these reasons, the local fire marshal with the assistance of the police will control the site until the building is no longer a threat to surrounding properties and the companies have secured the site from the general public.

During this time, the majority owner of the building should be arranging for a demolition contractor to mobilize to the site with the primary objective of reaching the cable entrance facility for a damage assessment. The results of this assessment would then dictate immediate plans for restoration, both short term and permanent.

In a less catastrophic event, i.e., the building is still standing and the cable entrance facility is usable, the situation is more complex. The site will initially be controlled by local authorities until the threat to adjacent property has diminished. Once the site is returned to the control of the companies, the following events should occur.

An initial assessment of the main building infrastructure systems (mechanical, electrical, fire and life safety, elevators, and others) will establish building needs. Once these needs are determined, the majority owner should lead the building restoration efforts. There may be situations where the site will not be totally restored within the confines of the building. The companies must individually determine their needs and jointly assess the cost of permanent restoration to determine the overall plan of action.

Multiple restoration trailers from each company will result in the need for designated space and installation order. This layout and control is required to maximize the amount of restoration equipment that can be placed at the site, and the priority of placements.

Care must be taken in this planning to insure other restoration efforts have logistical access to the building. Major components of telephone and building equipment will need to be removed and replaced. A priority for this equipment must also be jointly established to facilitate overall site restoration. (Example: If the AC switchgear has sustained damage, this would be of the highest priority in order to regain power, lighting, and HVAC throughout the building.)

If the site will not accommodate the required restoration equipment, the companies would then need to quickly arrange with local authorities for street closures, rights of way or other possible options available.

3.2 ENVIRONMENTAL CONCERNS

In the worse case scenario, many environmental concerns must be addressed. Along with the police and fire marshal, the state environmental protection department will be on site to monitor the situation.

Items to be concerned with in a large central office building could include:

1. Emergency engine fuel supply. Damage to the standby equipment and the fuel handling equipment could have created "spill" conditions that have to be handled within state and federal regulations.
2. Asbestos containing materials that may be spread throughout the wreckage. Asbestos could be in many components of building, electrical, mechanical, outside plant distribution, and telephone systems.
3. Lead and acid. These materials could be present in potentially large quantities depending upon the extent of damage to the power room.
4. Mercury and other regulated compounds resident in telephone equipment.
5. Other compounds produced by the fire or heat.

Once a total loss event occurs at a large site, local authorities will control immediate clean up (water placed on the wreckage by the fire department) and site access.

At some point, the companies will become involved with local authorities in the overall planning associated with site clean up and restoration. Depending on the clean up approach taken, delays in the restoration of several hours to several days may occur.

In a less severe disaster, items listed above are more defined and can be addressed individually depending on the damage.

In each case, the majority owner should coordinate building and environmental restoration as well as maintain proper planning and site control.

4.0 THE EMERGENCY CONTROL CENTER (ECC)

The ECC is located in the Colonnade Building in Birmingham, Alabama. During an emergency, the ECC staff will convene a group of pre-selected experts to inventory the damage and initiate corrective actions. These experts have regional access to BellSouth's personnel and equipment and will assume control of the restoration activity anywhere in the nine-state area.

In the past, the ECC has been involve with restoration activities resulting from hurricanes, ice storms and floods. They have demonstrated their capabilities during these calamities as well as

during outages caused by human error or equipment failures. This group has an excellent record of restoring service as quickly as possible.

During a major disaster, the ECC may move emergency equipment to the affected location, direct recovery efforts of local personnel and coordinate service restoration activities with the CLECs. The ECC will attempt to restore service as quickly as possible using whatever means is available; leaving permanent solutions, such as the replacement of damaged buildings or equipment, for local personnel to administer.

Part of the ECC's responsibility, after temporary equipment is in place, is to support the NMC efforts to return service to the CLECs. Once service has been restored, the ECC will return control of the network to normal operational organizations. Any long-term changes required after service is restored will be made in an orderly fashion and will be conducted as normal activity.

5.0 RECOVERY PROCEDURES

The nature and severity of any disaster will influence the recovery procedures. One crucial factor in determining how BellSouth will proceed with restoration is whether or not BellSouth's equipment is incapacitated. Regardless of who's equipment is out of service, BellSouth will move as quickly as possible to aid with service recovery; however, the approach that will be taken may differ depending upon the location of the problem.

5.1 CLEC OUTAGE

For a problem limited to one CLEC (or a building with multiple CLECs), BellSouth has several options available for restoring service quickly. For those CLECs that have agreements with other CLECs, BellSouth can immediately start directing traffic to a provisional CLEC for completion. This alternative is dependent upon BellSouth having concurrence from the affected CLECs.

Whether or not the affected CLECs have requested a traffic transfer to another CLEC will not impact BellSouth's resolve to re-establish traffic to the original destination as quickly as possible.

5.2 BELLSOUTH OUTAGE

Because BellSouth's equipment has varying degrees of impact on the service provided to the CLECs, restoring service from damaged BellSouth equipment is different. The outage will probably impact a number of Carriers simultaneously. However, the ECC will be able to initiate immediate actions to correct the problem.

A disaster involving any of BellSouth's equipment locations could impact the CLECs, some more than others. A disaster at a Central Office (CO) would only impact the delivery of traffic to and from that one location, but the incident could affect many Carriers. If the Central Office is a Serving Wire Center (SWC), then traffic from the entire area to those Carriers served from that switch would also be impacted. If the switch functions as an Access Tandem, or there is a tandem in the building, traffic from every CO to every CLEC could be interrupted. A disaster that destroys a facility hub could disrupt various traffic flows, even though the switching equipment may be unaffected.

The NMC would be the first group to observe a problem involving BellSouth's equipment. Shortly after a disaster, the NMC will begin applying controls and finding re-routes for the completion of as much traffic as possible. These reroutes may involve delivering traffic to alternate Carriers upon receiving approval from the CLECs involved. In some cases, changes in translations will be required. If the outage is caused by the destruction of equipment, then the ECC will assume control of the restoration.

5.2.1 Loss of a Central Office

When BellSouth loses a Central Office, the ECC will

- a) Place specialists and emergency equipment on notice;
- b) Inventory the damage to determine what equipment and/or functions are lost;
- c) Move containerized emergency equipment and facility equipment to the stricken area, if necessary;
- d) Begin reconnecting service for Hospitals, Police and other emergency agencies; and
- e) Begin restoring service to CLECs and other customers.

5.2.2 Loss of a Central Office with Serving Wire Center Functions

The loss of a Central Office that also serves as a Serving Wire Center (SWC) will be restored as described in section 5.2.1.

5.2.3 Loss of a Central Office with Tandem Functions

When BellSouth loses a Central Office building that serves as an Access Tandem and as a SWC, the ECC will

- a) Place specialists and emergency equipment on notice;
- b) Inventory the damage to determine what equipment and/or functions are lost;
- c) Move containerized emergency equipment and facility equipment to the stricken area, if necessary;
- d) Begin reconnecting service for Hospitals, Police and other emergency agencies;
- e) Re-direct as much traffic as possible to the alternate access tandem (if available) for delivery to those CLECs utilizing a different location as a SWC;
- f) Begin aggregating traffic to a location near the damaged building. From this location, begin re-establishing trunk groups to the CLECs for the delivery of traffic normally found on the direct trunk groups. (This aggregation point may be the alternate access tandem location or another CO on a primary facility route.)

- g) Begin restoring service to CLECs and other customers.

5.2.4 Loss of a Facility Hub

In the event that BellSouth loses a facility hub, the recovery process is much the same as above. Once the NMC has observed the problem and administered the appropriate controls, the ECC will assume authority for the repairs. The recovery effort will include

- a) Placing specialists and emergency equipment on notice;
- b) Inventorying the damage to determine what equipment and/or functions are lost;
- c) Moving containerized emergency equipment to the stricken area, if necessary;
- d) Reconnecting service for Hospitals, Police and other emergency agencies; and
- e) Restoring service to CLECs and other customers. If necessary, BellSouth will aggregate the traffic at another location and build temporary facilities. This alternative would be viable for a location that is destroyed and building repairs are required.

5.3 COMBINED OUTAGE (CLEC AND BELLSOUTH EQUIPMENT)

In some instances, a disaster may impact BellSouth's equipment as well as the CLECs'. This situation will be handled in much the same way as described in section 5.2.3. Since BellSouth and the CLECs will be utilizing temporary equipment, close coordination will be required.

6.0 T1 IDENTIFICATION PROCEDURES

During the restoration of service after a disaster, BellSouth may be forced to aggregate traffic for delivery to a CLEC. During this process, T1 traffic may be consolidated onto DS3s and may become unidentifiable to the Carrier. Because resources will be limited, BellSouth may be forced to "package" this traffic entirely differently than normally received by the CLECs. Therefore, a method for identifying the T1 traffic on the DS3s and providing the information to the Carriers is required.

7.0 ACRONYMS

- CO - Central Office (BellSouth)
- DS3 - Facility that carries 28 T1s (672 circuits)
- ECC - Emergency Control Center (BellSouth)
- CLEC - Competitive Local Exchange Carrier
- NMC - Network Management Center
- SWC - Serving Wire Center (BellSouth switch)
- T1 - Facility that carries 24 circuits

Hurricane Information

During a hurricane, BellSouth will make every effort to keep CLECs updated on the status of our network. Information centers will be set up throughout BellSouth Telecommunications. These centers are not intended to be used for escalations, but rather to keep the CLEC informed of network related issues, area damages and dispatch conditions, etc.

Hurricane-related information can also be found on line at http://www.interconnection.bellsouth.com/network/disaster/dis_resp.htm. Information concerning Mechanized Disaster Reports can also be found at this website by clicking on CURRENT MDR REPORTS or by going directly to <http://www.interconnection.bellsouth.com/network/disaster/mdrs.htm>.

BST Disaster Management Plan

BellSouth maintenance centers have geographical and redundant communication capabilities. In the event of a disaster removing any maintenance center from service another geographical center would assume maintenance responsibilities. The contact numbers will not change and the transfer will be transparent to the CLEC.

Attachment 1

Resale

TABLE OF CONTENTS

1 DISCOUNT RATES 3

2 DEFINITION OF TERMS 3

3 GENERAL PROVISIONS 3

4 BELLSOUTH’S PROVISION OF SERVICES TO AT&T..... 8

5 MAINTENANCE OF SERVICES..... 12

6 ANNOYANCE CALLS..... 12

7 LINE INFORMATION DATABASE (“LIDB”) 13

8 RAO HOSTING 13

9 OPTIONAL DAILY USAGE FILE (“ODUF”)..... 13

10 ENHANCED OPTIONAL DAILY USAGE FILE (“EODUF”) 13

EXHIBIT A.....15

EXHIBIT B.....17

EXHIBIT C.....19

RESALE

1 Discount Rates

- 1.1 The discount applied to AT&T's purchase of BellSouth's telecommunications services for purposes of resale shall be as set forth in Exhibit A, attached hereto and incorporated herein by this reference. The discount shall be applied to the retail rate for the telecommunications service purchased by AT&T. Such discount shall reflect the costs attributable to any marketing, billing, collection and other costs avoided by BellSouth as specified in the Act, by the FCC and the appropriate state public service commission.

2 Definition of Terms

- 2.1 COMPETITIVE LOCAL EXCHANGE COMPANY ("CLEC") means a telephone company certificated by the public service commission to provide local exchange service.
- 2.2 CUSTOMER OF RECORD means the entity responsible for placing application for service; requesting additions, rearrangements, maintenance or discontinuance of service; and payment in full of charges incurred.
- 2.3 DEPOSIT means assurance provided by a Customer of Record in the form of cash, surety bond or bank letter of credit to be held by BellSouth.
- 2.4 END USER means the ultimate user of the telecommunications services.
- 2.5 NEW SERVICES means functions, features or capabilities that are not currently offered by BellSouth. This includes packaging of existing services or combining a new function, feature or capability with an existing service.
- 2.6 RESALE means an activity wherein a CLEC, such as AT&T, subscribes to the telecommunications services of BellSouth and then offers those telecommunications services to the public.

3 General Provisions

- 3.1 At the request of AT&T and pursuant to the requirements of the Act, AT&T may resell the telecommunications services of BellSouth that

BellSouth provides at retail to subscribers who are not telecommunications carriers, subject to the terms and conditions specifically set forth herein. Notwithstanding the foregoing, the exclusions and limitations on services available for resale will be as set forth in Exhibit B, attached hereto and incorporated herein by this reference. AT&T may purchase resale services from BellSouth for its own use in operating its business. The resale discount will apply to those services under the following conditions:

- 3.1.1 AT&T must resell services to other end users;
- 3.1.2 AT&T must order services through resale interfaces, i. e., the Local Carrier Service Center ("LCSC") and/or appropriate Resale Account Teams pursuant to Attachment 7 of this Agreement, incorporated herein by this reference; and
- 3.1.3 AT&T cannot be a CLEC for the single purpose of selling to itself.
- 3.2 The provision of services by BellSouth to AT&T does not constitute a joint undertaking for the furnishing of any service.
- 3.3 AT&T will be the Customer of Record for all telecommunications services purchased from BellSouth for the purpose of resale. Except as specified herein, BellSouth will take orders from, bill and expect payment from AT&T for said services.
- 3.4 AT&T will be BellSouth's single point of contact for all services purchased pursuant to this Attachment 1. BellSouth shall have no contact with the end user except to the extent provided for herein.
- 3.5 BellSouth will continue to bill the end user for any services that the end user specifies it wishes to receive directly from BellSouth. BellSouth will continue to directly market its own telecommunications products and services and in doing so may establish independent relationships with end users of AT&T.
- 3.6 Neither Party shall interfere with the right of any person or entity to obtain service directly from the other Party.
- 3.7 Current telephone numbers may normally be retained by end user. However, telephone numbers are the property of BellSouth and are assigned to the service furnished. AT&T has no property right to the telephone number or any other call number designation associated with services furnished by BellSouth, and no right to the continuance of service through any particular central office. BellSouth reserves the

right to change such numbers, or the central office designation associated with such numbers, or both, solely in accordance with BellSouth's practices and procedures and on a non-discriminatory basis.

- 3.8 For the purpose of the resale of BellSouth's telecommunications services by AT&T, BellSouth will provide AT&T with an on line access to telephone numbers pursuant to Attachment 5, Sections 1.2 and 1.3, incorporated herein by this reference.
- 3.9 Service is furnished subject to the condition that it will not be used for any unlawful purpose.
- 3.10 BellSouth can refuse service when it has grounds to believe that service will be used in violation of the law.
- 3.11 BellSouth accepts no responsibility to any person for any unlawful act committed by AT&T or its end users as part of providing service to AT&T for purposes of resale or otherwise.
- 3.12 The characteristics and methods of operation of any circuits, facilities or equipment provided by any person or entity other than BellSouth shall not:
 - 3.12.1 Interfere with or impair service over any facilities of BellSouth, its affiliates, or its connecting and concurring carriers involved in its service; or
 - 3.12.2 Impair the privacy of any communications.
- 3.13 If AT&T utilizes a BellSouth resold telecommunications service in a manner other than which the service was originally intended as described in BellSouth's retail tariffs, AT&T has the responsibility to notify BellSouth. BellSouth will only provision and maintain said service consistent with the terms and conditions of the tariff describing said service.
- 3.14 Facilities and/or equipment utilized by BellSouth to provide service to AT&T remain the property of BellSouth.
- 3.15 White page directory listings will be provided in accordance with Section 20 of the General Terms and Conditions of this Agreement, incorporated herein by this reference.

- 3.16 BellSouth provides electronic access to customer record information pursuant to Section 2 of Attachment 6, incorporated herein by this reference. Customer record information includes customer specific information in the Customer Record Information System ("CRIS") and the Regional Street Address Guide ("RSAG"). AT&T agrees not to view, copy, or otherwise obtain access to the customer record information of any end user without that end user's permission, and further agrees that AT&T will obtain access to customer record information only in strict compliance with all applicable state and federal laws, rules and regulations.
- 3.17 All costs incurred by BellSouth to develop and implement the electronic interfaces shall be recovered from CLECs who utilize the services, unless otherwise ordered by the Commission. Charges for the electronic interfaces developed and implemented to access Operational Support Systems functions ("OSS") for accessing customer record information and placing local service requirements for resale shall be as set forth in Exhibit A, attached hereto and incorporated herein by this reference.
- 3.18 Where available to BellSouth's end users, BellSouth shall provide the following telecommunications services at a discount to allow for voice mail services:
- Simplified Message Desk Interface - Enhanced ("SMDI-E")
 - Simplified Message Desk Interface ("SMDI")
 - Message Waiting Indicator ("MWI") stutter dialtone and message waiting light feature capabilities
 - Call Forward on Busy/Don't Answer ("CF-B/DA")
 - Call Forward on Busy ("CF/B")
 - Call Forward Don't Answer ("CF/DA")
- 3.19 Further, BellSouth messaging services set forth in BellSouth's Messaging Service Information Package, available on BellSouth's website, shall be made available for resale without the wholesale discount.
- 3.20 BellSouth's Inside Wire Maintenance Service Plans may be made available for resale at rates, terms and conditions as set forth by BellSouth and without the wholesale discount.

- 3.21 If AT&T requests a special assembly, AT&T agrees to pay the costs incurred by BellSouth for providing the requested special assembly. The costs will be provided to AT&T prior to providing the service. Such costs could include both recurring and non-recurring charges and shall exclude any costs attributable to any marketing, billing, collection or other costs that will be avoided by BellSouth in providing the service to AT&T.
- 3.22 Recovery of charges associated with implementing Number Portability shall be as set forth in Section 2.5 of Attachment 5, incorporated herein by this reference.
- 3.23 BellSouth agrees to notify AT&T electronically of any changes in the terms and conditions under which it offers telecommunications services to end users who are non-telecommunications carriers, including, but not limited to, the introduction or discontinuance of any features, functions, services or promotions, at least forty-five (45) days prior to the effective date of any such change, whichever is earlier. AT&T recognizes that certain revisions may occur between the time BellSouth notifies AT&T of a change pursuant to this Section and BellSouth's tariff filing of such change. BellSouth shall notify AT&T of such revisions consistent with BellSouth's internal notification process but AT&T accepts the consequences of such mid-stream changes as an uncertainty of doing business and, therefore, will not hold BellSouth responsible for any resulting inconvenience or cost incurred by AT&T unless caused by the intentional misconduct of BellSouth for the purposes of this Section. The notification given pursuant to this Section will not be used by either Party to market its offering of such changed services externally in advance of BellSouth's filing of any such changes. Any change requiring modifications to BellSouth's electronic interface will be as set forth in Section 1.5 of Attachment 7, incorporated herein by this reference. The notification given pursuant to this Section will not be used by either Party to market its offering of such changed services externally in advance of BellSouth's filing of any such changes.
- 3.24 BellSouth shall provide 911/E911 for AT&T end users in the same manner that it is provided to BellSouth end users. BellSouth shall provide and validate AT&T end users information to the PSAP. BellSouth shall use its service order process to update and maintain, on the same schedule that it uses for its end users, the AT&T end users service information in the ALI/DMS data base (Automatic

Location Identification/Database Management System) used to support 911/E911 services.

- 3.25 BellSouth and AT&T shall provide local and toll dialing parity to each other with no unreasonable dialing delays. Dialing parity shall be provided for all originating telecommunications services that require dialing to route a call. BellSouth and AT&T shall permit similarly situated telephone exchange service end users to dial the same number of digits to make a local telephone call notwithstanding the identity of the end user's or the called party's telecommunications service provider.
- 3.26 Pursuant to 47 CFR Section 51.617, BellSouth will bill AT&T end user common line charges identical to the end user common line charges BellSouth bills its end users.
- 3.27 In general, BellSouth will not become involved in disputes between AT&T and AT&T's end users over resold services. If a dispute does arise that cannot be settled without the involvement of BellSouth, AT&T shall contact the designated service center for resolution. BellSouth will make every effort to assist in the resolution of the dispute and will work with AT&T to resolve the matter in as timely a manner as possible. AT&T may be required to submit documentation to substantiate the claim.

4 **BellSouth's Provision of Services to AT&T**

- 4.1 AT&T agrees that its resale of BellSouth services shall be as follows:
- 4.1.1 No terms and conditions, including use and user restrictions, shall be applicable to the resale of BellSouth's telecommunications services except for a restriction on the resale of cross-class selling and reasonable, nondiscriminatory and narrowly tailored terms, conditions and limitations in the underlying BellSouth tariffs.
- 4.1.2 Hotel and Hospital PBX services are the only telecommunications services available for resale to Hotel/Motel and Hospital customers, respectively. Similarly, Access Line Service for Customer Provided Coin Telephones is the only local service available for resale to Independent Payphone Provider ("IPP") customers. Shared Tenant Service customers can only be sold those local exchange access services available in BellSouth's A23 Shared Tenant Service Tariff in the states of Florida, Georgia, North Carolina and South Carolina, and

in A27 in the states of Alabama, Kentucky, Louisiana, Mississippi and Tennessee.

- 4.1.3 BellSouth reserves the right to periodically audit services purchased by AT&T to establish compliance with the terms and conditions set forth above. Such audit shall not occur more than once in a calendar year. AT&T shall make any and all records and data available to BellSouth or BellSouth's auditors on a reasonable basis. BellSouth shall bear the cost of said audit.
- 4.1.4 Resold services are subject to the same terms and conditions as are specified for such services when furnished to an individual end user of BellSouth in the appropriate section of BellSouth's tariffs. Specific tariff features (e.g., a usage allowance per month) shall not be aggregated across multiple resold services unless specifically provided for in BellSouth's retail tariffs.
- 4.1.5 Telephone numbers transmitted via any resold service feature are intended solely for the use of the end user of the feature.
- 4.1.6 BellSouth will provide AT&T will at least the capability to provide an AT&T end user the same experience as BellSouth provides its own end users with respect to all resold services. The capability provided to AT&T by BellSouth shall be in accordance with standards or other measurements that are at least equal to the level that BellSouth provides or is required to provide by law or its own internal procedures.

4.2 **CLASS and Custom Features Requirements**

- 4.2.1 AT&T may purchase the entire set of CLASS and custom features and functions, or a subset of any one or any combination of such features, on an end user-specific basis, without restriction on the minimum or maximum number of lines and features that may be purchased for any one level of service to the extent such restrictions do not apply to BellSouth's retail end users.

4.3 **Voluntary Federal Customer Financial Assistance Programs**

- 4.3.1 Local telecommunications services provided to low-income subscribers, pursuant to requirements established by the appropriate state regulatory body, include programs such as Voluntary Federal Customer Financial Assistance Program and Link-Up America ("Voluntary Federal Customer Financial Assistance Programs"). When a BellSouth end user eligible for the Voluntary Federal Customer

Financial Assistance Program, or other similar state programs, chooses to obtain local service from AT&T, BellSouth shall forward available information regarding such end user's eligibility to participate in such programs to AT&T, in electronic format in accordance with procedures to be mutually established by the Parties and applicable state and federal law.

4.4 **Hospitality Service**

4.4.1 BellSouth shall provide all blocking, screening, and all other applicable functions available for hospitality lines.

4.5 **Blocking Service**

4.5.1 BellSouth shall provide call blocking of 700, 900, and 976 services individually or in any combination upon request, including bill to third party and collect calls from AT&T on a line, trunk, or individual service basis at parity with what BellSouth provides its end users.

4.6 **Routing to Directory Assistance, Operator and Repair Services**

4.6.1 BellSouth shall make available to AT&T the ability to route calls utilizing the customized or compatible signaling protocol:

4.6.1.1 Local Directory Assistance calls (411, (NPA) 555-1212) dialed by AT&T end users directly to the AT&T directory assistance services platform;

4.6.1.2 Local operator services calls (0+, 0-) dialed by AT&T end users directly to the AT&T local operator services platform. Such traffic shall be routed over trunk groups between BellSouth end offices and the AT&T local operator services platform, using standard operator services dialing protocols of 0+ or 0-; and

4.6.1.3 Repair calls (e.g., 611) dialed by AT&T end users directly to the AT&T repair center.

4.6.2 All routing shall permit AT&T end users to dial the same telephone numbers for AT&T directory assistance, local operator service and repair that similarly situated BellSouth end users dial for reaching equivalent BellSouth services.

4.6.2.1 BellSouth branding is the default service level.

- 4.6.2.2 Unbranding, custom branding, and self branding require AT&T to order customized routing for each originating BellSouth end office identified by AT&T. Rates for customized routing are set forth in Exhibit C of this Attachment, incorporated herein by this reference.
- 4.6.2.3 Customer branding and self branding require AT&T to order dedicated trunking from each BellSouth end office identified by AT&T, to either the BellSouth Traffic Operator Position System ("TOPS") or AT&T operator service provider. Rates for trunks are set forth in applicable BellSouth tariffs, or Exhibit A of Attachment 2, incorporated herein by this reference.
- 4.6.2.4 Unbranding – Unbranded directory assistance and/or operator call processing calls ride common trunk groups provisioned by BellSouth from those end offices identified by AT&T to the BellSouth TOPS. These calls are routed to "no announcement."
- 4.7 **Busy Line Verification and Emergency Line Interrupt**
- 4.7.1 Where BellSouth does not route operator services traffic to AT&T's platform, BellSouth shall perform BLV/ELI for AT&T on resold BellSouth lines. Where BellSouth routes operator services traffic to AT&T's platform, BellSouth shall provide BLV/ELI services when requested by AT&T operators.
- 4.8 **Directory Assistance and Operator Services**
- 4.8.1 Where BellSouth provides directory assistance service on behalf of AT&T, it shall be at the same level of directory assistance service available to BellSouth end users. If requested by AT&T, BellSouth will provide AT&T directory assistance service under the AT&T brand. Where not technically feasible, such calls will be unbranded.
- 4.8.2 Where BellSouth provides operator services on behalf of AT&T, it shall be at the same level of service available to BellSouth end users. BellSouth will provide service in accordance with all applicable state requirements for operator services.
- 4.8.3 Upon request, BellSouth agrees to provide AT&T operator services branded as an AT&T call. Where not technically feasible, such calls will be unbranded.

4.8.4 Additionally, BellSouth warrants that such service will provide the following minimum capabilities to AT&T end users:

4.8.4.1 Instant credit on calls, as provided to BellSouth end users; and

4.8.4.2 Routing of calls to AT&T when requested via existing Operator Transfer Service ("OTS").

5 **Maintenance of Services**

5.1 AT&T and BellSouth will adopt and adhere to the standards contained in the applicable CLEC Work Center Operational Understanding between AT&T and BellSouth dated February 3, 1997, or as amended, incorporated herein by this reference, regarding maintenance and installation of service.

5.2 Services resold pursuant to this Attachment 1 shall be maintained by BellSouth.

5.3 AT&T or its end users may not rearrange, move, disconnect, remove or attempt to repair any facilities owned by BellSouth, other than by connection or disconnection to any interface means used, except with the written consent of BellSouth.

5.4 BellSouth will bill AT&T for handling troubles that are found not to be in BellSouth's network pursuant to its standard time and material charges. The standard time and material charges will be no more than what BellSouth charges to its retail end users for the same services.

5.5 BellSouth reserves the right to contact AT&T's end users on AT&T's behalf, if deemed necessary, for maintenance purposes.

5.6 BellSouth shall ensure that all BellSouth representatives who receive inquiries regarding AT&T services when providing services on behalf of AT&T: (i) refer such inquiries to AT&T at a telephone number provided by AT&T; (ii) provide AT&T supplied telephone numbers to callers who inquire about AT&T services or products; (iii) do not in any way disparage or discriminate against AT&T, or its products or services; and (iv) do not provide information about BellSouth products or services.

6 **Annoyance Calls**

6.1 BellSouth will continue to process calls made to the annoyance call center and will advise AT&T when it is determined that annoyance calls are originated from one of its end user's locations. BellSouth shall be indemnified, defended and held harmless by AT&T and/or the end user against any claim, loss or damage arising from providing this information to AT&T. It is the responsibility of AT&T to take the corrective action necessary with its end users who make annoying calls. Failure to do so will result in BellSouth's disconnecting the end user's service pursuant to Attachment 6 of this Agreement, incorporated herein by this reference.

7 **Line Information Database ("LIDB")**

7.1 The Parties' agreement relating to LIDB storage is included in Exhibit A to Attachment 6 of this Agreement, incorporated herein by this reference.

8 **RAO Hosting**

8.1 The Parties' agreement relating to RAO Hosting is included in Exhibit B to Attachment 6 of this Agreement, incorporated herein by this reference.

9 **Optional Daily Usage File ("ODUF")**

9.1 The Parties' agreement relating to ODUF is included in Exhibit C to Attachment 6 of this Agreement, incorporated herein by this reference.

10 **Enhanced Optional Daily Usage File ("EODUF")**

10.1 The Parties' agreement relating to EODUF is included in Exhibit D of Attachment 6 of this Agreement, incorporated herein by this reference.

APPLICABLE DISCOUNTS

The telecommunications services available for purchase by AT&T for the purposes of resale to AT&T end users shall be available at the following discount off of the retail rate. If AT&T cancels an order for telecommunications services for the purposes of resale, any costs incurred by BellSouth in conjunction with the provisioning of that order will be recovered in accordance with the applicable sections of the General Subscriber Services Tariff and the Private Line Service Tariff.

DISCOUNT*			
<u>STATE</u>	<u>RESIDENCE</u>	<u>BUSINESS</u>	<u>CSAs***</u>
ALABAMA	16.3%	16.3%	
FLORIDA	21.83%	16.81%	
GEORGIA	20.3%	17.3%	
KENTUCKY	16.79%	15.54%	
LOUISIANA	20.72%	20.72%	9.05%
MISSISSIPPI	15.75%	15.75%	
NORTH CAROLINA	21.5%	17.6%	
SOUTH CAROLINA	14.8%	14.8%	8.98%
TENNESSEE**	16%	16%	

* When AT&T provides Resale service in a cross boundary area (areas that are part of the local serving area of another state's exchange) the rates, regulations and discounts for the tariffing state will apply. Billing will be from the serving state.

** In Tennessee, if AT&T provides its own operator services and directory services, the discount shall be 21.56%. AT&T must provide written notification to BellSouth within 30 days prior to providing its own operator services and directory services to qualify for the higher discount rate of 21.56%.

*** Unless noted in this column, the discount for Business will be the applicable discount rate for CSAs.

RATES FOR INTERFACE TO OPERATIONAL
SUPPORT SYSTEMS

BellSouth has developed and made available the following mechanized systems by which AT&T may submit LSRs electronically.

LENS	Local Exchange Navigation System
EDI	Electronic Data Interface
EDI-PC	Electronic Data Interface – Personal Computer
TAG	Telecommunications Access Gateway

LSRs submitted by means of one of these interactive interfaces will incur an electronic interface ordering charge as specified in the Table below. Such charges will not be refunded if the order is canceled. An individual LSR will be identified for billing purposes by its Purchase Order Number (“PON”). LSRs submitted by means other than one of these interactive interfaces (mail, fax, courier, etc.) will incur a manual order charge as specified in the table below:

INTERFACE RATES	<u>Electronic</u> Per LSR received from AT&T by one of the interactive electronic interfaces	<u>Manual</u> Per LSR received from AT&T by means other than one of the interactive electronic interfaces
Electronic Interface LSR Charge	\$10.89	\$22.00
USOC	SOMEK	SOMAN

Note: In addition to the electronic interface charges, applicable discounted service order and related discounted charges apply per the tariff.

DENIAL/RESTORAL ELECTRONIC INTERFACE CHARGE

In the event AT&T provides a list of customers to be denied and restored, rather than an LSR, each location on the list will require a separate PON and therefore will be billed as one LSR per location.

Note: Supplements or clarifications to a previously billed LSR will not incur another electronic interface charge.

**EXCLUSIONS AND LIMITATIONS
ON SERVICES AVAILABLE FOR RESALE**

	Type of Service	AL		FL		GA		KY		LA	
		Resale?	Discount?	Resale?	Discount?	Resale?	Discount?	Resale?	Discount?	Resale?	Discount?
1	Grandfathered Services (Note 1)	Yes	Yes	Yes	Yes	Yes	Yes	Yes	Yes	Yes	Yes
2	Contract Service Arrangements(Note 2)	Yes	Yes	Yes	Yes	Yes	Yes	Yes	Yes	Yes	Yes
3	Promotions - > 90 Days(Note 3)	Yes	Yes	Yes	Yes	Yes	Yes	Yes	Yes	Yes	Yes
4	Promotions - < 90 Days (Note 3)	Yes	No	Yes	No	Yes	No	No	No	Yes	No
5	Lifeline/Link Up Services	Yes	Yes	Yes	Yes	Yes	Yes	Note 4	Note 4	Yes	Yes
6	911/E911 Services	Yes	Yes	Yes	Yes	Yes	Yes	Yes	Yes	No	No
7	N11 Services	Yes	Yes	Yes	Yes	Yes	Yes	No	No	No	No
8	AdWatch SM Svc (See Note 5)	Yes	No	Yes	No	Yes	No	Yes	No	Yes	No
9	MemoryCall [®] Service	Yes	No	Yes	No	Yes	No	Yes	No	Yes	No
10	Mobile Services	Yes	No	Yes	No	Yes	No	Yes	No	Yes	No
11	Federal Subscriber Line Charges	Yes	No	Yes	No	Yes	No	Yes	No	Yes	No
12	Non-Recurring Charges	Yes	Yes	Yes	Yes	Yes	Yes	Yes	Yes	Yes	Yes
13	Customer Line Charge – Number Portability	Yes	No	Yes	No	Yes	No	Yes	No	Yes	No

	Type of Service	MS		NC		SC		TN	
		Resale?	Discount?	Resale?	Discount?	Resale?	Discount?	Resale?	Discount?
1	Grandfathered Services (Note 1)	Yes	Yes	Yes	Yes	Yes	Yes	Yes	Yes
2	Contract Service Arrangements	Yes	Yes	Yes	Yes	Yes	Yes	Yes	Yes
3	Promotions - > 90 Days(Note 3)	Yes	Yes	Yes	Yes	Yes	Yes	Yes	Note 6
4	Promotions - < 90 Days (Note 3)	Yes	No	Yes	No	Yes	No	No	No
5	Lifeline/Link Up Services	Yes	Yes	Yes	Yes	Yes	Yes	Yes	Note 4
6	911/E911 Services	Yes	Yes	Yes	Yes	Yes	Yes	Yes	Yes
7	N11 Services	No	No	No	No	Yes	Yes	Yes	Yes
8	AdWatch SM Svc (See Note 5)	Yes	No	Yes	No	Yes	No	Yes	No
9	MemoryCall [®] Service	Yes	No	Yes	No	Yes	No	Yes	No
10	Mobile Services	Yes	No	Yes	No	Yes	No	Yes	No
11	Federal Subscriber Line Charges	Yes	No	Yes	No	Yes	No	Yes	No
12	Non-Recurring Charges	Yes	Yes	Yes	Yes	Yes	Yes	Yes	No
13	Customer Line Charge – Number Portability	Yes	No	Yes	No	Yes	No	Yes	No

Applicable Notes:

- 1 **Grandfathered services** can be resold only to existing subscribers of the grandfathered service.
- 2 (Georgia) CSAs are available for resale at the same terms and conditions offered to BellSouth's customers.
- 3 Where available for resale, **promotions** will be made available only to customers who would have qualified for the promotion had it been provided by BellSouth directly.
- 4 **Lifeline/Link Up** services may be offered only to those subscribers who meet the criteria that BellSouth currently applies to subscribers of these services. In Kentucky, AT&T is responsible for funding its own Lifeline and Link Up benefit. In Tennessee, AT&T shall purchase

BellSouth's Message Rate Service at the stated tariff rate, less the wholesale discount. AT&T must further discount the wholesale Message Rate Service to Lifeline customers with a discount which is no less than the minimum discount that BellSouth now provides. AT&T is responsible for recovering the Subscriber Line Charge from the National Exchange Carriers Association interstate toll settlement pool just as BellSouth does today. The maximum rate that AT&T may charge for Lifeline Service shall be capped at the flat retail rate offered by BellSouth.

5 AdWatchSM Service is tariffed as BellSouth[®] AIN Virtual Number Call Detail Service.

6 In Tennessee, long-term **promotions** (offered for more than ninety (90) days) may be obtained at one of the following rates:

(a) the stated tariff rate, less the wholesale discount;

(b) the promotional rate (the promotional rate offered by BellSouth will not be discounted further by the wholesale discount rate)

Customized routing, per unique line class code, per request, per switch	USOC	Kentucky
NRC	USRCR	\$229.65
NRC – Manual Service Order		

**BELLSOUTH / ATT RATES
ODUF/EODUF
KENTUCKY**

CATEGORY	NOTES	RATE ELEMENT	Interim	Zone	BCS	USOC	RATES				OSS RATES								
							Nonrecurring		Nonrecurring Disconnect		Svc Order Submitted Elec per LSR	Svc Order Submitted Manually per LSR	Incremental Charge - Manual Svc Order vs. Electronic-1st	Incremental Charge - Manual Svc Order vs. Electronic-Add'l	Incremental Charge - Manual Svc Order vs. Electronic-Disc 1st	Incremental Charge - Manual Svc Order vs. Electronic-Disc Add'l			
							Rec	First Add'l	First Add'l	SOMEC							SOMAN	SOMAN	SOMAN
ODUF/EODUF/CMD5/CNAM-Resale																			
		ENHANCED OPTION DAILY USAGE FILE (EODUF)*																	
		EODUF: Message Processing, per message				N/A	\$0.253134												
		OPTIONAL DAILY USAGE FILE (ODUF)*																	
		ODUF: Recording, per message				N/A	\$0.0000152												
		ODUF: Message Processing, per message				N/A	\$0.0046880												
		ODUF: Message Processing, per Magnetic Tape provisioned				N/A	\$48.78												
		ODUF: Data Transmission (CONNECT:DIRECT), per message				N/A	\$0.00010785												
	in applicable BellSouth tariff or as negotiated by the Parties upon request by either Party. Notes: It is the intent of the Parties that where applicable state commissions have approved rates for network elements and other services set forth in this Agreement as of the date hereof, such rates have been																		
	*Interim																		

ATTACHMENT 2

NETWORK ELEMENTS AND COMBINATIONS

TABLE OF CONTENTS

1. INTRODUCTION..... 3

2. NETWORK ELEMENTS AND COMBINATIONS..... 3

3. LOCAL LOOPS 10

294. NETWORK INTERFACE DEVICE (“NID”) 32

5. SUBLOOPS 34

6. SWITCHING CAPABILITIES..... 43

7. OPERATOR SERVICE AND DIRECTORY ASSISTANCE SERVICE..... 50

8. INTEROFFICE TRANSMISSION FACILITIES 59

9. SIGNALING NETWORKS AND CALL-RELATED DATABASES 65

10. DIRECTORY ASSISTANCE DATABASE SERVICE 73

11. SERVICE MANAGEMENT SYSTEM 75

12. TRUNK INTERFACE REQUIREMENTS 77

EXHIBIT A, RATES

EXHIBIT B, CALLING NAME DELIVERY (CNAM) DATABASE SERVICES

NETWORK ELEMENTS AND COMBINATIONS

1. Introduction

- 1.1 This Attachment sets forth the Network Elements and Combinations that BellSouth agrees to offer to AT&T in accordance with its obligations under Section 251(c)(3) of the Act. The specific terms and conditions that apply to the Network Elements and Combinations are described below in this Attachment 2. The prices for the Network Elements and Combinations are set forth in Exhibit A of this Attachment 2.
- 1.2 BellSouth agrees to provide to AT&T access to and AT&T agrees to utilize Network Elements and Combinations in accordance with effective rules and regulations of the FCC or Commission. The Parties further agree that should such rules and regulations become vacated or stayed, that the Parties shall conform this Attachment 2 accordingly.

2. Network Elements and Combinations

- 2.1 Network Element is defined to mean a facility or equipment used in the provision of a telecommunications service. Such term may include, but is not limited to, features, functions, and capabilities that are provided by means of such facility or equipment, including but not limited to, subscriber numbers, databases, signaling systems, and information sufficient for billing and collection or used in the transmission, routing, or other provision of a telecommunications service. BellSouth offers access to the following Network Elements: local loops; network interface devices; subloops; switching capabilities; interoffice transmission facilities; operations support systems functions; signaling networks; access to call-related databases; and service management systems, as set forth in this Attachment 2. BellSouth shall offer operator services and directory assistance pursuant to the rates, terms and conditions contained within this Attachment.
- 2.2 BellSouth shall provide to AT&T for the provision of a telecommunications service, non-discriminatory access to Network Elements at any technically feasible point on terms and conditions that are just, reasonable, and non-discriminatory in accordance with the terms and conditions of the Agreement.
- 2.3 BellSouth will permit AT&T to interconnect AT&T's facilities or facilities provided to AT&T by an ILEC or by third parties with each of BellSouth's Network Elements at any point designated by AT&T that is

technically feasible. Any request by AT&T to interconnect at a point not previously established (i) in accordance with the terms of the Agreement or (ii) under any arrangement BellSouth may have with another telecommunications carrier, shall be subject to the process set forth in Attachment 10 of this Agreement, incorporated herein by this reference.

- 2.4 BellSouth will provide Network Elements and Combinations to AT&T via a standard interface that allows the Network Elements and Combinations to operate within the appropriate technical specification unless another technically feasible interface is agreed to by the Parties. AT&T, at its option, may designate other interfaces using the process set forth in Attachment 10 of this Agreement, incorporated herein by this reference.
- 2.5 AT&T may use one or more Network Elements and Combinations to provide to itself, its affiliates and to AT&T end users any feature, function, capability or service option that such Network Elements and Combinations are technically capable of providing or any feature, function, capability or service option that is described in the Telcordia and other industry standard technical references.
- 2.6 In addition to Combinations furnished by BellSouth to AT&T hereunder, BellSouth shall permit AT&T to combine any Network Element or Network Elements provided by BellSouth with another Network Element, other Network Elements or Access Services obtained from BellSouth or with compatible network components provided by AT&T or provided by third parties to AT&T to provide telecommunications services to AT&T, its affiliates and to AT&T end users.
- 2.7 Except upon request by AT&T, BellSouth shall not separate requested Network Elements that BellSouth currently combines.
- 2.7.1 Currently Combined Network Elements are defined as Network Elements that BellSouth ordinarily combines in its own network in the manner in which they are typically combined even if the particular Network Elements being ordered are not actually physically connected at the time the order is placed. To the extent AT&T orders combinations of network elements that are new, not actually physically connected in BellSouth's network at the time the order is being placed, BellSouth shall combine such network elements for AT&T at the rates set forth in Exhibit A, incorporated herein by reference, and consistent with the Kentucky Commission's Order in Case 2000-465. To the extent AT&T seeks to obtain other Combinations BellSouth ordinarily combines in its network which have not been specifically priced by the Commission when purchased in combined form, AT&T may purchase

such Combinations at the sum of the stand-alone rates. AT&T may pursue the bona fide request process set forth in Attachment 10 to seek a different rate.

- 2.8 For each Network Element, BellSouth shall provide a demarcation point (e.g., an interconnection point at a digital signal cross connect or light guide cross connect panel or a main distribution frame) and, if necessary, access to such demarcation point, which AT&T agrees is suitable. However, where BellSouth provides Combinations to AT&T, BellSouth may provide the existing interconnections and no demarcation point shall exist between the combined Network Elements.
- 2.9 The recurring and nonrecurring rates set forth in Exhibit A of this Attachment 2 are for Currently Combined Network Elements for new, which is defined as typically combined and not actually physically connected in BellSouth's network at the time the order is being placed, and those combinations that are actually physically connected at the time the order is placed. On an interim basis, for those Currently Combined Network Elements where the particular elements being ordered are not actually physically connected at the time the order is placed, the nonrecurring charge for such Currently Combined Network Elements shall be the sum of the stand-alone nonrecurring charges of the individual Network Elements which make up the combination, and the nonrecurring combining charge, consistent with the Kentucky Commission's Order in Case 2000-465. These rates are interim, subject to true-up, pursuant to the Commission's Order in Case No. 2000-465. Upon the Commission's determination of non-recurring rates, AT&T and BellSouth will amend this agreement to incorporate said rates.
- 2.9.1 Combination Offerings
- 2.9.1.1 2-wire voice grade port, voice grade loop, unbundled end office switching, unbundled end office trunk port, common transport per mile per MOU, common transport facilities termination, tandem switching, and tandem trunk port.
- 2.9.1.2 2-wire voice grade Coin port, voice grade loop, unbundled end office switching, unbundled end office trunk port, common transport per mile per MOU, common transport facilities termination, tandem switching, and tandem trunk port.
- 2.9.1.3 2-wire voice grade DID port, voice grade loop, unbundled end office switching, unbundled end office trunk port, common transport per mile

per MOU, common transport facilities termination, tandem switching, and tandem trunk port.

2.9.1.4 2-wire CENTREX port, voice grade loop, unbundled end office switching, unbundled end office trunk port, common transport per mile per MOU, common transport facilities termination, tandem switching, and tandem trunk port.

2.9.1.5 2-wire ISDN Basic Rate Interface, voice grade loop, unbundled end office switching, unbundled end office trunk port, common transport per mile per MOU, common transport facilities termination, tandem switching, and tandem trunk port.

2.9.1.6 4-wire ISDN Primary Rate Interface, DS1 loop, unbundled end office switching, unbundled end office trunk port, common transport per mile per MOU, common transport facilities termination, tandem switching, and tandem trunk port.

2.9.1.7 4-wire DS1 Trunk port, DS1 Loop, unbundled end office switching, unbundled end office trunk port, common transport per mile per MOU, common transport facilities termination, tandem switching, and tandem trunk port.

2.9.1.8 4-wire DS1 Loop with normal serving wire center channelization interface, 2-wire voice grade ports (PBX), 2-wire DID ports, unbundled end office switching, unbundled end office trunk port, common transport per mile per MOU, common transport facilities termination, tandem switching, and tandem trunk port.

2.10 Attachment 2 of this Agreement describes the Network Elements that AT&T and BellSouth have identified as of the Effective Date of this Agreement and are not exclusive. Either Party may identify additional or revised Network Elements as necessary to improve services to end users, to improve network or service efficiencies or to accommodate changing technologies, or end user demand. Upon BellSouth's offering of a new or revised Network Element, BellSouth shall notify AT&T of the existence of and the technical characteristics of the new or revised Network Element. Upon AT&T's identification of a new or revised Network Element, it shall make a request pursuant to Attachment 10 of this Agreement, incorporated herein by this reference.

2.11 **Special Access Conversions**

- 2.11.1 AT&T may not convert special access services to combinations of loop and transport network elements, whether or not AT&T self-provides its entrance facilities (or obtains entrance facilities from a third party), unless, AT&T uses the combination to provide a significant amount of local exchange service, in addition to exchange access service, to a particular customer. To the extent AT&T requests to convert any special access services to combinations of loop and transport network elements at UNE prices, AT&T shall provide to BellSouth a written letter, pursuant to the notices requirement as set forth in Section 17 of the General Terms and Conditions, certifying that AT&T is providing a significant amount of local exchange service (as described in this Section) over such combinations.
- 2.11.2 The certification letter shall indicate under what local usage option AT&T seeks to qualify for conversion of special access circuits. AT&T shall be automatically deemed to be providing a significant amount of local exchange service over such combinations if it certifies that they are meeting one of the following options:
- 2.11.3 AT&T certifies that it is the exclusive provider of an end user's local exchange service. The loop-transport combinations must terminate at AT&T's collocation arrangement in at least one BellSouth central office. This option does not allow loop-transport combinations to be connected to BellSouth's tariffed services. Under this option, AT&T is the end user's only local service provider, and thus, is providing more than a significant amount of local exchange service. AT&T can then use the loop-transport combinations that serve the end user to carry any type of traffic, including using them to carry 100% interstate access traffic; or
- 2.11.4 AT&T certifies that it provides local exchange and exchange access service to the end user customer's premises and handles at least one third of the end user customer's local traffic measured as a percent of total end user customer local dialtone lines; and for DS1 circuits and above, at least 50% of the activated channels on the loop portion of the loop-transport combination have at least 5% local voice traffic individually, and the entire loop facility has at least 10% local voice traffic. When a loop-transport combination includes multiplexing, each of the individual DS1 circuits must meet this criteria. The loop-transport combination must terminate at AT&T's collocation arrangement in at least one BellSouth central office. This option does not allow loop-transport combinations to be connected to BellSouth tariffed services; or
- 2.11.5 The requesting carrier certifies that at least 50% of the activated channels on a circuit are used to provide originating and terminating

local dialtone service and at least 50% of the traffic on each of these local dialtone channels is local voice traffic, and that the entire loop facility has at least 33% local voice traffic. When a loop-transport combination includes multiplexing, each of the individual DS1 circuits must meet this criteria. This option does not allow loop-transport combinations to be connected to BellSouth's tariffed services. Under this option, collocation is not required. AT&T does not need to provide a defined portion of the end user's local service, but the active channels on any loop-transport combination, and the entire facility, must carry the amount of local exchange traffic specified in this option.

- 2.11.6 In addition, there may be extraordinary circumstances where AT&T is providing a significant amount of local exchange service, but does not qualify under any of the three options set forth in Section 2.11. In such case, AT&T may petition the FCC for a waiver of the local usage options set forth herein. If a waiver is granted, then upon AT&T's request the Parties shall amend this Agreement to the extent necessary to incorporate the terms of such waiver for such extraordinary circumstance.
- 2.11.7 BellSouth may, at its sole expense, audit AT&T records in order to determine AT&T's compliance with the local usage options set forth above. All audits shall be conducted by a third party independent auditor, and AT&T and the FCC shall be given thirty (30) days written notice of scheduled audit. Such audit shall occur no more than one time in a calendar year, unless results of an audit find noncompliance with the significant amount of local exchange service requirement. In the event of noncompliance, AT&T shall reimburse BellSouth for the cost of the audit. If, based on its audits, BellSouth concludes that AT&T is not providing a significant amount of local exchange traffic over the combinations of loop and transport network elements, BellSouth may file a complaint with the appropriate Commission, pursuant to the dispute resolution process as set forth in the Interconnection Agreement. In the event that BellSouth prevails, BellSouth may convert such combinations of loop and transport network elements to special access services and may seek appropriate retroactive reimbursement from AT&T.
- 2.11.8 The Parties further acknowledge that on a going forward basis, AT&T may purchase additional special access service under BellSouth's applicable tariffs and convert such special access circuits to EELs, pursuant to the terms of this Agreement, subject to such circuits meeting the local usage options of this Section 2.11.
- 2.11.9 When an existing special access service circuit employed by AT&T is converted to Network Elements and/or Combination, BellSouth shall

not disconnect and re-connect the elements. When combinations of loop and transport network elements include multiplexing, each of the individual DS1 circuits must meet the above criteria.

2.11.10 Conversion of Service As Is

2.11.10.1 AT&T may request conversion of existing retail services to non-switched combinations of unbundled network elements by submitting an LSR or a conversion spreadsheet, provided by BellSouth, to the LCSC for record changes. For the conversion of retail services to switched combinations, AT&T may request such conversions on a single LSR for all services billed under the same Account Telephone Number or master billing account. AT&T may consolidate onto a single LSR, up to four end user accounts to a single Account Telephone Number where the accounts are for the same end user and are the same type and end user location. BellSouth will project manage conversions of fifteen (15) or more lines.

2.12 Standards for Network Elements

2.12.1 BellSouth shall comply with the requirements set forth in the technical references, as well as any performance or other requirements identified in this Agreement, to the extent that they are consistent with the greater of BellSouth's actual performance or applicable industry standards.

2.12.2 If one or more of the requirements set forth in this Agreement are in conflict, the parties shall mutually agree on which requirement shall apply. If the parties cannot reach agreement, the dispute resolution process set forth in Section 16 of the General Terms and Conditions of this Agreement, incorporated herein by this reference, shall apply.

2.12.3 The quality of the Network Elements as well as the quality of the access to said Network Elements that BellSouth provides to AT&T shall be, to the extent technically feasible, at least equal to that which BellSouth provides to itself. Detailed performance standards and measurements for Network Elements are set forth in Attachment 9 of this Agreement, incorporated herein by this reference.

2.12.4 Except as otherwise specified by law, BellSouth shall not impose any limitations, restrictions or requirements on requests for or use of Network Elements or Combinations that would impair the ability of AT&T to offer a telecommunications service in the manner AT&T intends, provided such use does not impede or impair the use of BellSouth's network by BellSouth or any other telecommunications carrier utilizing said network.

3. Local Loops

3.1 Definition

3.1.1 The local loop network element ("Loop(s)") is defined as a transmission facility between a distribution frame (or its equivalent) in BellSouth's central office and the loop Demarcation Point at an end user's premises, including inside wire owned by BellSouth. The local loop network element includes all features, functions, and capabilities of such transmission facilities, including dark fiber and attached electronics (except those used for the provision of advanced services, such as Digital Subscriber Line Access Multiplexers) and line conditioning.

3.2 The provisioning of service to AT&T will require cross-office cabling and cross-connections within the central office to connect the loop to a local switch or to other transmission equipment in Collocation Space. These cross-connects are not considered part of the loop. The purchase of such cross-connects shall be pursuant to Attachment 4, incorporated herein by this reference.

3.3 Line Conditioning. The rates for line conditioning shall be as set forth in Exhibit A of this Attachment 2 incorporated herein by this reference. BellSouth shall condition lines required to be unbundled wherever AT&T requests, whether or not BellSouth offers advanced services to the end user on that loop.

3.3.1 Line conditioning is defined as the removal from the loop of any devices that may diminish the capability of the loop to deliver high-speed switched wireline telecommunications capability, including xDSL service. Such devices include, but are not limited to, bridge taps, low pass filters, and range extenders.

3.3.2 In so far as it is technically feasible, BellSouth shall test and report trouble for all the features, functions and capabilities of conditioned lines, and may not restrict testing to voice-transmission only.

3.3.3 If an AT&T order for a local loop is cancelled or modified by AT&T or an AT&T end-user, and the cancellation or modification is not caused by BellSouth, AT&T will compensate BellSouth costs incurred by BellSouth for provisioning or accommodating the modification of the local loop, unless such costs are already being recovered through approved rates. AT&T may charge BellSouth order modification or cancellation charges using the same rates and conditions as BellSouth utilizes for assessing such charges to AT&T, if the modification or cancellation is caused by BellSouth.

3.4 Order Coordination (OC) allows BellSouth and AT&T to coordinate the installation of the SL2 Loops, Unbundled Digital Loops (UDL) and other Loops where OC may be purchased as an option. OC for physical conversions will be scheduled by BellSouth during normal business hours on a committed due date. OC will be provided in accordance with the chart set forth below.

3.5 As a chargeable option on all loops except unbundled copper loop ("UCL"), and is billed in addition to the OC charge. BellSouth will offer Order Coordination Time Specific ("OC-TS"). This will allow AT&T the ability to specify the time that the coordinated conversion takes place. The OC-TS charge for orders due on the same day at the same location will be applied on a per appropriate local service request basis.

	Order Coordination (OC)	Order Coordination – Time Specific (OC-TS)	Test Points	DLR	Charge for Dispatch and Testing if No Trouble Found
SL-1	Chargeable Option	Chargeable Option	Not available	Chargeable Option – ordered as Engineering Information Document	Charged for Dispatch inside and outside Central Office
SL-2	Included	Chargeable Option	Included	Included	Charged for Dispatch outside Central Office
Unbundled Digital Loop	Included	Chargeable Option (except on Universal Digital Channel)	Included (where appropriate)	Included	Charged for Dispatch outside Central Office
Unbundled Copper Loop	Chargeable in accordance with Section 2	Not available	Included	Included	Charged for Dispatch outside Central Office
For UVL-SL1 and UCLs, AT&T must order and will be billed for both OC and OC-TS if requesting OC-TS.					

3.6 Unbundled Voice Loops (UVL) may be provisioned using any type of facility that will support voice grade services. This may include loaded copper, non-loaded copper, digital loop carrier systems, fiber or a

combination of any of these facilities. BellSouth will offer UVL in two different service levels - Service Level One (SL1) and Service Level Two (SL2).

- 3.6.1 Unbundled Voice Loop - SL1 (UVL-SL1) loops are 2-wire loop start circuits, will be non-designed, and will not have remote access test points. OC will be offered as a chargeable option on SL1 loops when reuse of existing facilities has been requested by AT&T. AT&T may also order OC-TS when a specified conversion time is requested. OC-TS is a chargeable option for any coordinated order and is billed in addition to the OC charge. An Engineering Information (EI) document can be ordered as chargeable option. The EI document provides loop make up information which is similar to the information normally provided in a Design Layout Record. Upon issuance of a non-coordinated order in the service order system, SL1 loops will be activated on the due date in the same manner and time frames that BellSouth normally activates POTS-type loops for its customers.
- 3.6.2 BellSouth will offer unbundled voice-grade loops ("UVL") Service Level Two ("SL2"). SL2 loops shall have test points, will be designed with a design layout record ("DLR") provided to AT&T, and will be provided with order coordination ("OC"). The OC feature will allow AT&T to coordinate the installation of the loop with the disconnect of an existing end user's service and/or number portability service. In these cases, BellSouth will perform the order conversion with standard order coordination at its discretion during normal work hours.
- 3.6.3 AT&T will be responsible for isolating troubles on SL2 loops. Once AT&T has isolated a trouble to the BellSouth provided loop, AT&T will issue a trouble report to BellSouth on the loop. BellSouth will take the actions necessary to repair the loop if trouble actually exists. BellSouth will repair these loops in the same time frames that BellSouth repairs similarly situated loops to its end users.
- 3.6.4 If AT&T reports a trouble on SL2 loops and no trouble actually exists, BellSouth will charge AT&T for any dispatching and testing (outside the central office) required by BellSouth in order to confirm the loop's working status.
- 3.6.5 BellSouth will also offer unbundled digital loops ("UDL"). They will be designed, will be provisioned with test points (where appropriate), and will come standard with Order Coordination and a DLR.
- 3.6.6 AT&T will be responsible for isolating troubles on UDL. Once AT&T has isolated a trouble to the BellSouth provided loop, AT&T will issue a trouble report to BellSouth on the loop. BellSouth will take the actions

necessary to repair the loop if a trouble actually exists. BellSouth will repair these loops in the same time frames that BellSouth repairs similarly situated loops to its end users.

- 3.6.7 If AT&T reports a trouble on a UDL and no trouble actually exists, BellSouth will charge AT&T for any dispatching and testing (outside the central office) required by BellSouth in order to confirm the loop's working status.
- 3.6.8 In addition to the UVLs and UDLs, BellSouth shall make available an UCL. The UCL will be a copper twisted pair loop that is unencumbered by any intervening equipment (e.g., filters, load coils, range extenders, digital loop carrier, or repeaters). The UCL will be offered in two versions - short and long. A short UCL (18 kft or less) will be provisioned according to Resistance Design parameters. The long UCL (beyond 18kft) will be used when AT&T wants to condition copper loops longer than 18kft by removing load coils and other intervening equipment. BST will only ensure electrical continuity and balance relative to tip and ring on UCLs.
- 3.6.9 The UCL will be a designed circuit, with or without conditioning, provisioned with a test point and come standard with a DLR. OC will be offered as a chargeable option on all UCL loops. OC-TS will not be offered on UCLs.
- 3.6.10 The UCL is a dry copper loop and is not intended to support any particular telecommunications service. AT&T may use the UCL loop for a variety of services, including xDSL (e.g., ADSL and HDSL) services, by attaching appropriate terminal equipment of AT&T's choosing. AT&T will determine the type of service that will be provided over the loop.
- 3.6.11 Because the UCL shall be an unbundled loop offering that is separate and distinct from BellSouth's ADSL and HDSL capable loop offerings, AT&T agrees that BellSouth's UCL loop will not be held to the service level and performance expectations that will apply to its ADSL and HDSL unbundled loop offerings. BellSouth shall only be obligated to maintain copper continuity and provide balance to ground relative to tip and ring on UCL.
- 3.6.12 The UCL shall be provided to AT&T in accordance with BellSouth's applicable industry standards.
- 3.7 Provisioning and Coordinated Cutovers**

- 3.7.1 Section 3.7 contains the initial coordination procedures that the Parties agree to follow when AT&T orders and BellSouth provisions the conversion of active BellSouth retail end users to a service configuration by which AT&T will serve such end users by unbundled Loops and number portability (hereinafter referred to as “Hot Cuts”). Both Parties agree that these procedures may need to be refined or augmented if necessary as experience in ordering and provisioning Hot Cuts is gained, and they further agree to implement the improvement procedure provided in Section 3.7.4 below.
- 3.7.1.1 Except as otherwise agreed by the Parties, the time intervals for Hot Cuts shall be monitored and shall conform to the performance standards and consequences for failure to meet the specified standards as reflected in Attachment 9 of this Agreement, which is incorporated herein by this reference.
- 3.7.1.2 The following coordination procedures shall apply when BellSouth retail service is being converted to service to be provided by AT&T utilizing a SL2 local loop (as that term is defined in Section 3.7.3.1.3 below) provided by BellSouth to AT&T with SPNP or PNP (as these two acronyms are defined in Attachment 5, incorporated herein by this reference).
- 3.7.1.3 AT&T shall order Services and Elements as set forth in this Attachment 2 and BellSouth shall provide a Firm Order Confirmation (“FOC”) (as that term and acronym are defined in Attachment 7, incorporated herein by this reference).
- 3.7.2 Ordering
- 3.7.2.1 AT&T shall request Hot Cuts from BellSouth by delivering to BellSouth a valid Local Service Request (“LSR”) using BellSouth’s ordering interfaces described in Attachment 7 to this Agreement, incorporated herein by this reference. AT&T may specify a Due Date or Frame Due Time, as defined below, at any time, including twenty-four (24) hours a day and seven (7) days a week. AT&T shall specify whether its service order is to be provisioned by BellSouth as either: (a) Order Coordination (“OC”); or (b) Order Coordination—Time Specific (“OC-TS”). OC shall mean the type of service order used by AT&T to request that BellSouth provision a Hot Cut on the particular calendar date as specified on the LSR and confirmed on the FOC as set forth in Section 3.7.2.3 below, at any time during that day, referred to in this Section as the “Due Date.” OC-TS shall mean the type of service order used by AT&T to request that BellSouth provision a Hot Cut on the particular day returned on the FOC as set forth in Section 3.7.2.3 below and at the particular time specified on the FOC, referred to in

this Section as the "Frame Due Time." AT&T shall pay the appropriate rate for either OC or OC-TS as set forth in Attachment 2. AT&T will be billed and will pay overtime for conversions requested and occurring outside of BellSouth's normal hours of operation as defined in Section 3.7.2.2 below.

- 3.7.2.1.1 Until such time as BellSouth's systems can deliver the requested frame due time on the FOC as set forth above, AT&T shall rely on the time requested on the LSR.
- 3.7.2.2 For purposes of this Section, BellSouth's normal hours of operation for personnel performing physical wire work are defined as follows:
 - 3.7.2.2.1 Monday – Friday: 8:00 a.m. – 5:00 p.m. (Excluding Holidays) (Resale/UNE non-coordinated, coordinated orders and order coordination-time specific)
 - 3.7.2.2.2 Saturday: 8:00 a.m. – 5:00 p.m. (Excluding Holidays) (Resale/UNE non-coordinated orders)
 - 3.7.2.2.3 The above hours are defined as the time of day where the work is being performed.
 - 3.7.2.2.4 Normal hours of operation for the various BellSouth centers supporting ordering, provisioning and maintenance are as set forth in Attachment 7 and incorporated herein by this reference. Normal hours of operation for the BellSouth centers providing AT&T support will be equal to the hours of operation that BellSouth provisions services to its affiliates, end users, and other CLECs.
 - 3.7.2.2.5 It is understood and agreed that BellSouth technicians involved in provisioning service to AT&T may work shifts outside of BellSouth's regular working hours as defined in Section 3.7.2.2 above (e.g., the employee's shift ends at 7:00 p.m. during daylight savings time). To the extent that AT&T requests that work necessarily required in the provisioning of service to be performed outside BellSouth's normal hours of operation and that work is performed by a BellSouth technician during his or her scheduled shift such that BellSouth does not incur any additional costs in performing the work on behalf of AT&T, BellSouth will not assess AT&T additional charges beyond the rates and charges specified in this Agreement.
 - 3.7.2.2.6 AT&T will not be assessed overtime charges where BellSouth elects to perform a coordinated hot cut outside of BellSouth's normal hours of operation. However, AT&T will pay overtime charges subject to the provisions of Section 3.7.2.2.5 above, where AT&T requests a time

specific conversion which based on the completion intervals outlined in Section 3.7.3.6 requires BellSouth to complete the conversion outside of BellSouth's normal hours of operation. BellSouth normal hours of operation are defined in Section 3.7.2.2 above of this Attachment 2 as well as Attachment 7, incorporated herein by this reference.

- 3.7.2.2.7 Upon receipt of the LSR, BellSouth's Operational Support System (hereinafter "BellSouth's OSS") shall examine the service order to determine whether it contains all the information necessary for BellSouth to process the service order. BellSouth shall review the information provided on the LSR and identify and reject any errors contained in the information provided by AT&T for the current view of the LSR.
- 3.7.2.2.8 BellSouth shall provide AT&T real-time, electronic access to its LFACS system in the pre-ordering phase to allow AT&T (1) to access loop makeup in accordance with Attachment 2 incorporated herein by this reference and (2) to validate its connecting facility assignments (CFA) prior to the issuance of an LSR. Implementation of such shall be determined by the current Change Control Process Guidelines outlined in Attachment 7. However, BellSouth commits that the CFA LFACS feature will be included in release 10.0 unless an alternative release delivery is mutually agreed to by both parties.
- 3.7.2.2.9 If BellSouth does not deliver CFA LFACS access as outlined in Section 3.7.2.2.8 above, BellSouth will waive OCTS charges for any time specific conversions where a post FOC CFA conflict occurs until such time as BellSouth provides CFA LFACS access as outlined in Section 3.7.2.2.8 above. Upon facility assignment validation by AT&T and upon receipt of AT&T's LSR, BellSouth may issue clarifications to FOCs (Post-FOC Clarification) if BellSouth determines that a connecting facility assignment ("CFA") assigned on an AT&T LSR is in conflict with BellSouth records.
- 3.7.2.2.10 Both parties agree that post FOC clarifications should not occur, provided AT&T checks the status of the CFA utilizing the real-time preorder LFACS access, as referenced in Section 3.7.2.2.8 above, prior to the issuance of an LSR, and BellSouth completes disconnect orders in a timely manner through updating its own CFA database and performing the required physical work. BellSouth and AT&T will investigate and address adverse trends of post FOC clarifications via the process improvement mechanism outlined in Section 3.7.4 below.
- 3.7.2.2.11 BellSouth and AT&T will work cooperatively to ensure data base integrity is achieved between AT&T and BellSouth CFA assignments. This cooperative effort will include at a minimum: (1) AT&T ensuring

that its processes support data base integrity, e.g., timely issuance of disconnects, proper assigning of facilities pending on canceled LSRs, and use of information provided by BellSouth to allow AT&T to identify and synchronize such data base; and (2) BellSouth will ensure that it processes AT&T requests for cancellation of local service requests in a time frame that allows AT&T to accurately maintain its CFA records. Until such time BellSouth provides LFACS access to AT&T in accordance with Section 3.7.2.2.8 above, BellSouth agrees to continue processing disconnects to correct CFA data base discrepancies via a BellSouth provided spread sheet. Once access to LFACS is provided to AT&T, in accordance with Section 3.7.2.2.8 above, AT&T agrees to submit individual LSRs to correct data base discrepancies and will discontinue using the spread sheet method unless the parties mutually agree otherwise.

- 3.7.2.2.12 BellSouth will provide AT&T with data base information via the BellSouth Interconnection Services website at weekly intervals and BellSouth and AT&T will work jointly to identify and resolve any discrepancies between BellSouth and AT&T databases containing the CFA assignments.
- 3.7.2.3 Firm Order Commitment (“FOC”)
 - 3.7.2.3.1 Pursuant to Section 3.7.2.1 above, for purposes of this Section, a “Firm Order Commitment” or “FOC” is a notification from BellSouth to AT&T that a service order is valid and error free and that BellSouth has committed to provision the service order on the date specified on the LSR and confirmed on the FOC and or on the date and time specified on the LSR and confirmed on the FOC for time specific conversions. BellSouth’s committed due date is the date BellSouth strives to deliver service but is not a guaranteed date and may be altered due to facility or manpower shortages and acts of God.
 - 3.7.2.3.2 For the initial LSR, BellSouth should not provide AT&T with either a request for clarification or a reject message after BellSouth provides AT&T a FOC, except as outlined in Section 3.7.2.2.9 above. Supplemental LSRs must be submitted via the method utilized to submit the original LSR e.g. mechanized or manual unless conditions warrant otherwise and mutually agreed to by both parties.
 - 3.7.2.3.3 BellSouth’s measurement of FOC/reject performance as stated in Section 3.7.2.3.1 above will be set forth in Attachment 9, incorporated herein by this reference.
- 3.7.3 Provisioning

- 3.7.3.1 Either party shall notify the other as soon as it becomes aware of any jeopardy condition which may arise that would jeopardize BellSouth's committed due date or OC-TS, as applicable, of providing service to AT&T.
- 3.7.3.1.1 Upon receipt of the FOC pursuant to Section 3.7.2.3.1, AT&T shall notify the customer of the Due Date and or Due Time (OC-TS order). Either party shall notify the other party immediately if either party becomes unable to make the Hot Cut at the Due Time and / or on the Due Date specified. New scheduled due dates and times shall be within BellSouth's normal hours of operations unless mutually agreed to by both parties.
- 3.7.3.1.2 Excluding facility shortages, acts of God or unforeseen force shortages, if BellSouth changes the date of a conversion from the date returned on the FOC, the new due date will be no greater than three (3) business days from the original requested date.
- 3.7.3.1.3 In the event BellSouth does not complete a conversion on the date returned on the FOC or does not complete a time specific conversion as requested due solely to BellSouth reasons, the following circumstances shall occur: (a) BellSouth shall document the order as a Missed Appointment pursuant to the appropriate service quality measurement outlined in Attachment 9 and incorporated herein by this reference and (b) AT&T will not re-negotiate nor consider a change in due date and or due time as a re-negotiation; and (c) AT&T will advise BellSouth to proceed as necessary to complete the cut; and BellSouth will not bill OCTS charges and AT&T will not be required to pay for OCTS where a missed appointment of OCTS has occurred as provided for in the service quality measurements of Attachment 9 and incorporated herein by this reference.
- 3.7.3.1.4 Conversions that cannot be completed as requested on the LSR and confirmed on the FOC, solely to AT&T or AT&T's end user reasons will be submitted to BellSouth as a Supplemental Order. Supplemental Orders must be submitted via the method utilized to submit the original LSR, e.g., mechanized or manual unless conditions warrant otherwise and mutually agreed to by both parties.
- 3.7.3.2 Upon receipt of the FOC, AT&T and BellSouth agree to follow the procedures for porting numbers as outlined in Attachment 5, incorporated herein by this reference.
- 3.7.3.2.1 In the event that BellSouth discovers, during the provisioning process, a conflict between BellSouth's database and its physical facilities, indicating a lack of BellSouth facilities, BellSouth shall issue a Pending

Facilities (“PF”) status by sending an electronic notice to AT&T, if the request was submitted electronically, or in the case of a manually submitted LSR, such notice will be provided via the PF report accessible via the Internet.

- 3.7.3.2.1.1 Pending Facilities order status occurs when a due date may be in jeopardy due to facility delay and may become a Missed Appointment due to BellSouth reasons.
- 3.7.3.2.1.2 In the event that BellSouth cannot meet its committed Due Date and or Due Time because of a PF condition due to a BellSouth facility shortage, the following shall occur: (a) BellSouth will notify AT&T as soon as the order is placed in PF status in accordance with Section 3.7.3.2.1 above; and (b) BellSouth shall document the order as a Missed Appointment (“MA”) within BellSouth’s internal systems, provided BellSouth is unable to complete the work on the date returned on the FOC; and (c) BellSouth will provide AT&T estimated service date (“ESD”) information at intervals that BellSouth provides such information to itself, its own end users, its affiliates or any other CLEC. BellSouth targets to provide ESD information within 5 business days from the date the PF condition occurs.
- 3.7.3.2.2 AT&T shall provide BellSouth with a toll free number as stated in the Implementation Contact Telephone Number (“ImpCon”) Field on the LSR that BellSouth shall commit to call and use for all notification to AT&T. In addition, an AT&T representative will answer and will respond within 5 minutes. Response as used in this section shall mean that the AT&T agent is ready to receive and record information provided by BellSouth.
- 3.7.3.2.3 In the event BellSouth does not find dial tone on the AT&T side when testing prior to the conversion date and time, and detects no trouble on the BellSouth side, BellSouth shall immediately notify AT&T. AT&T shall perform the appropriate internal tests and, if necessary, will dispatch a technician to its collocation site at the BellSouth Central Office. If the AT&T technician finds no trouble on the AT&T side when testing, AT&T will notify BellSouth. Both Parties will work cooperatively, to isolate and clear the trouble and arrange, if necessary, a joint meeting of a BellSouth technician and an AT&T technician at the last point of BellSouth’s responsibility at the collocation site. Both Parties’ technicians will meet at the collocation site to work cooperatively by jointly isolating the trouble, and repairing it. If either Party believes the trouble is not being resolved properly, either Party may escalate the matter for immediate resolution. BellSouth will continue to process the Service Order without requiring a supplemental order assuming that AT&T will correct the problem prior

to the cut date and time. If the problem is determined to be a BellSouth problem and the cut time has passed, BellSouth will waive non-recurring OC-TS charges pursuant to Section 3.7.3.1.3 above, and the Parties shall establish, by mutual consent, a new due time and or due date to be met through expedited processing.

- 3.7.3.2.4 Troubles referred to AT&T as referenced in Section 3.7.3.2.3 above will be repaired by the AT&T technician, if necessary. Unless AT&T notifies BellSouth that the "No Dial tone" issue has not been resolved, BellSouth shall continue to process the Service Order without requiring a supplemental order. AT&T agrees that BellSouth may rely on the lack of such notification to mean that AT&T believes it can resolve the "No Dial tone" issue prior to Due Date or Due Time. AT&T shall not be required to call BellSouth to communicate that the "No Dial Tone" issue has been resolved. If at the time of the cut, AT&T dial tone is not detected on the BellSouth collocation pair and AT&T and BellSouth agree that the problem is due to AT&T and cannot be resolved within 15 minutes, AT&T will be required to supplement the order, which will be submitted via the method utilized to submit the original LSR, and request a new due date and time. If AT&T is unable to correct the repair within 15 minutes, AT&T may request that BellSouth technicians standby until the condition is corrected by paying standby rates as provided for in FCC Tariff #1. If either Party believes that the process set forth herein is not satisfactorily implemented, the process improvement plan as described in Section 3.7.4.1 below will be applied
- 3.7.3.3 AT&T will ensure that dial tone is delivered to the BellSouth collocation pair 48 hours prior to due date.
- 3.7.3.3.1 For OC-TS or OC conversions, BellSouth will verify the cut-over time designated by AT&T for OCTS or verify the due date for OC conversions 24-48 hours in advance via telephone to ensure that the conversion is to be completed as ordered. In addition, BellSouth shall provide the following information at the time of this call: dial tone and the ANI test results, Due Date, frame due time if the order is an OC-TS order, the number of lines and the cable and pair assignment. This telephone call at [24-48] notifying AT&T with the above information stated in this Section, will be known as the "Concurrence Call." This verified information must be the same Due Date or OC-TS as sent back on the FOC unless the Parties jointly agree on or before this concurrence call on a new due date or OC-TS. Both parties will ensure OC-TS as identified in this section will commence within 15 minutes of the agreed time. BellSouth agrees to make the concurrence call at the same time or after the dial tone and ANAC test has been completed. In the unlikely event BellSouth does not complete the dial tone and ANAC test 24 hours prior to the due date,

BellSouth will either confirm that the conversion will take place at the scheduled conversion time or advise AT&T that it will not. If BellSouth advises AT&T that it will not meet the scheduled conversion date or time, BellSouth will document a missed due date or missed time specific conversion in accordance with Section 3.7.3.1.3 above.

- 3.7.3.3.2 BellSouth will advise AT&T, via jeopardy notice, as soon as BellSouth becomes aware of a jeopardy condition which would delay the delivery of service to AT&T as outlined in BellSouth's FOC or time of conversion as mutually agreed to or as ordered by AT&T.
- 3.7.3.3.3 Upon the issuance and receipt of a jeopardy notice, the Parties agree to follow mutually agreed upon business rules established for resolving various types of jeopardy conditions.
- 3.7.3.4 Due Date Activities
 - 3.7.3.4.1 The UNEC will coordinate with all internal groups within BellSouth to start the conversion at the scheduled conversion time. Once notified, the central office technician will verify AT&T dial tone at the tied in jumper at the BellSouth cable pair and will perform an ANAC verification of the line at the BellSouth cable pair. If dial tone is verified and the line is verified to the correct number, the BellSouth central office technician will monitor the line and when idle, will remove the BellSouth jumper and terminate at the BellSouth main distribution frame ("MDF") the tied in jumper to the AT&T collocation point. The BellSouth CO technician will then perform an ANAC verification of the line to verify AT&T dial tone and ensure the correct number is delivered to the BellSouth cable pair.
- 3.7.3.5 Activities After Hot Cut
 - 3.7.3.5.1 The UNEC will then advise AT&T via telephone call for all coordinated conversions that the cut is complete, pursuant to Section 3.7.3.2.2 above, and allow AT&T to accept or reject the service. BellSouth shall work cooperatively with AT&T to correct any problems associated with the conversion of the service which might result in AT&T's rejection of the service.
 - 3.7.3.5.2 If BellSouth fails to contact AT&T after the hot cut and in accordance with the Cut Complete Call stated in Sections 3.7.3.5.1 and 3.7.3.2.2 above (number stated in the "ImpCon" Field of the AT&T LSR) BellSouth shall document the order as a "Missed Appointment" within BellSouth's internal systems pursuant to Section 3.7.3.1.3 above.

- 3.7.3.5.3 BellSouth will hold open the conversion orders within the following time frames after the call specified in Section 3.7.3.5.1 above has been made:
 - 3.7.3.5.3.1 If the call is received by AT&T prior to 5:00 p.m. on the conversion day, BellSouth will hold the order open until 6:00 p.m.;
 - 3.7.3.5.3.2 If AT&T requests the order be held open for a longer time, BellSouth will hold the requested order open until 12:00 noon the following business day;
 - 3.7.3.5.3.3 If the call is received by AT&T after 5:00 p.m. on the conversion day, BellSouth will hold the order open until 12:00 noon the following business day unless otherwise agreed to by the parties;
 - 3.7.3.5.3.4 If BellSouth does not receive verbal acceptance by AT&T pursuant to the above conditions, BellSouth will deem the conversion accepted by AT&T.
- 3.7.3.5.4 BellSouth and AT&T reserve the right to change its internal hot cut activities as business needs dictate. Any change to the hot cut procedures contained in this Attachment will be discussed by the parties and will be implemented subject to the provisions of the process improvement mechanism as set forth in Section 3.7.4 below.
- 3.7.3.6 Loop Cut-Over Timing
 - 3.7.3.6.1 BellSouth shall complete the loop cut-over step and notify AT&T of such completion in accordance with the section, commencing with the specified time committed to on the FOC and ending no later than the following time limits depending on the number of lines being cut. In the case of a Coordinated Order Time Specific or OC conversion: 1-10 loops => 60 mins (1 hour); 11-30 loops => 120 mins. (2 hours) unless project managed; 31+ loops => Project Managed.
 - 3.7.3.6.2 BellSouth's commitment to performance as set forth in Attachment 9 of this Agreement is incorporated herein by this reference.
 - 3.7.3.6.3 Intervals for loops for a single end user on the same local service requests for loops greater than thirty (30) will be completed at intervals mutually coordinated by both parties through Project Management. Both parties recognize that certain conversions requiring multiple cut points may exceed the above intervals but in any event both parties will work cooperatively to limit service outage to an end user.

3.7.3.6.4 In the event BellSouth does not complete the loop cut-over step within the appropriate time limit provided in Section 3.7.3.6.1 above and notify AT&T of such completion in accordance with Section 3.7.3.5.1 above, AT&T may escalate such failure to the proper BellSouth official for expedited resolution immediately at the end of such time limit.

3.7.3.7 Completion Notice

3.7.3.7.1 BellSouth shall send AT&T completion notices when the LSRs are submitted electronically. If submitted manually, AT&T may determine the completion status for all LSRs by accessing the CSOTS Report via the Internet.

3.7.4 Process Improvement

3.7.4.1 Within seventy-five (75) calendar days of the Effective Date, the Parties agree to negotiate and adopt a process improvement method to be used throughout the term of this Agreement for amending and supplementing the initial procedures established in this Section. Such process shall be implemented by the Parties thirty (30) calendar days from the date such method is mutually developed. Both parties will work cooperatively to identify areas for improvement and, if applicable, develop and implement process changes resulting from such mutual cooperation. Such method will provide the procedures to be employed on an on-going basis by the Parties when one Party wishes to improve any of the initial provisions set out in this Section. Each improvement negotiated by the Parties must be documented in an Attachment to the initial procedures as mutually agreed by the Parties.

3.7.4.2 In the event that the Parties are unable to enter into the improvement method contemplated in Section 3.7.4.1 above within ninety (90) days of the Execution Date, the Parties agree to resolve any disputes in accordance with the dispute resolution process provided in Section 16 of the General Terms and Conditions of this Agreement. Additionally, the Parties agree to seek such resolution on an expedited basis of any dispute involving a procedure that adversely impacts a customer.

3.7.5 New Loop Provisioning – “Loop Only”

3.7.5.1 BellSouth will provision new loops at intervals outlined in the Products and Service Interval Guide.

3.7.5.2 BellSouth will perform pre-service testing to ensure AT&T dial tone and telephone number is delivered to the BellSouth loop.

- 3.7.5.3 If AT&T dial tone is not detected during pre-service testing, BellSouth will notify AT&T and will continue with the provisioning process assuming that AT&T will correct the problem prior to the due date.
- 3.7.5.4 AT&T will deliver dial tone and telephone number to the AT&T collocation point 48 hours prior to the due date.
- 3.7.5.5 BellSouth and AT&T will notify either party if the due date cannot be met for any reason.
- 3.7.5.6 Cooperative testing, trouble resolution, completion notification and acceptance testing as provided for in Ordering and Provisioning of Hot Cuts will apply, and is incorporated herein by this reference.
- 3.7.5.7 BellSouth will deliver to the ordered location at the end users premises, loops as outlined in TR 73600, or in the applicable industry standard.
- 3.7.5.8 Where a field visit is required to provision the loop, BellSouth will test the loop ordered by AT&T to the NID. Testing requested by AT&T to points beyond the NID will be billed a time and material charge at the same increments BellSouth charges its own end users. Requests for field testing where a dispatch is not required may be made by AT&T and where mutually agreed to, BellSouth will dispatch to perform additional field testing at rates billed on a time and material basis as mentioned in this section.
- 3.8 Technical Requirements
 - 3.8.1 BellSouth shall offer Loops capable of providing the following:
 - 3.8.1.1 2-wire analog voice grade Loop provides an effective 2-wire channel with 2-wire interfaces at each end that is suitable for the transport of analog voice grade (nominal 300 to 3300 Hz) signals and using either Loop-start or ground start signaling;
 - 3.8.1.2 4-wire analog voice grade Loop provides an effective 4-wire channel with 4-wire interfaces at each end that is suitable for the transport of analog voice grade (nominal 300 to 3300 Hz) signals. The service will operate with one of the following signaling types that may be specified when the service is ordered: Loop-start, ground-start, Loop-reverse-battery, duplex;
 - 3.8.1.3 2-wire ISDN digital grade Loop provides a channel with 2-wire interfaces at each end that is suitable for the transport of 144 kbps digital services using the ISDN 2B1Q line code;

- 3.8.1.4 AT&T will be responsible for providing BellSouth with a Service Profile Identifier (“SPID”) associated with a particular ISDN-cable loop and end user. With the SPID, BellSouth will be able to adequately test the circuit and ensure that it properly supports ISDN service;
- 3.8.1.5 ADSL-capable Loop – an ADSL-capable Loop is a basic Loop (2 or 4-wire) without any intervening equipment and is capable of permitting the transmission of communications both within the voice band and in frequency ranges above the voice band. An ADSL-capable Loop provided by BellSouth is designed to Revised Resistance Design (“RRD”) guidelines and is expected to support ADSL service;
- 3.8.1.6 HDSL-capable Loop – an HDSL-capable Loop is a basic Loop (2 or 4-wire) without any intervening equipment and is capable of permitting the transmission of communications both within the voice band and in frequency ranges above the voice band. An HDLS-capable Loop provided by BellSouth is designed to Carrier Serving Area (“CSA”) guidelines and is expected to support HDSL service;
- 3.8.1.7 4-wire DS-1 Loop provides a channel with 4-wire interfaces at each end. Each 4-wire channel may be equipped with DS-1 Loop repeaters suitable for the transport of 1.544 mbps digital signals simultaneously in both directions using PCM line code and may terminate on a smart jack; and
- 3.8.1.8 UCL is a dry copper Loop, not intended to support any particular telecommunications service. UCL Loops are offered pursuant to Section 3.7 of this Attachment 2. The UCL is available with a no signaling option.

3.9 High Frequency Spectrum Network Element

The Parties have agreed to move issues related to Line Sharing and Line Splitting to the Kentucky Public Service Commission Administrative Case No 382. The Parties agree to amend this agreement consistent with the Commission’s effective Order within sixty (60) days of the Commission’s final resolution of any exception or Motions for Reconsiderations filed by the Parties, and consistent with the FCC’s Order in CC Docket Nos. 98-147, *In the Matter of Deployment of Wireline Services Offering Advanced Telecommunications Capability*, and 96-98, *Implementation of the Local Competition Provisions of the Telecommunications Act of 1996*, released December 9, 1999 and the FCC’s further order in these dockets released on January 19, 2001. For Purposes of this Agreement the Parties have agreed to the following provisions:

3.9.1 General

- 3.9.1.1 BellSouth shall provide AT&T access to the high frequency portion of the local loop as an unbundled network element only where BellSouth is the voice service provider to the end user ("High Frequency Spectrum") at the rates set forth in Exhibit A.
- 3.9.1.2 The High Frequency Spectrum is defined as the frequency range above the voiceband on a copper loop facility carrying analog circuit-switched voiceband transmissions. Access to the High Frequency Spectrum is intended to allow AT&T the ability to provide Digital Subscriber Line ("xDSL") data services to the end user for which BellSouth provides voice services. The High Frequency Spectrum shall be available for any version of xDSL complying to Spectrum Management Class 5 of ANSI T1.417, *American National Standard for Telecommunications, Spectrum Management for Loop Transmission Systems*. BellSouth will continue to have access to the low frequency portion of the loop spectrum (from 300 Hertz to at least 3000 Hertz, and potentially up to 3400 Hertz, depending on equipment and facilities) for the purposes of providing voice service. AT&T shall only use xDSL technology that is within the PSD mask for Spectrum Management Class 5 as found in the above mentioned document.
- 3.9.1.3 Access to the High Frequency Spectrum requires an unconditioned, 2-wire copper Loop. An unloaded Loop is a copper Loop with no load coils, low-pass filters, range extenders, DAMLs, or similar devices and minimal bridged taps consistent with ANSI T1.413 and T1.601. BellSouth will provide Loop conditioning to AT&T in accordance with the Unbundled Loop Modification process set forth in Section 3.3 of this Attachment. BellSouth is not required to condition a Loop for access to the High Frequency spectrum if conditioning of that Loop significantly degrades BellSouth's voice service. If AT&T requests that BellSouth condition a Loop longer than 18,000 ft. and such conditioning significantly degrades the voice services on the Loop, AT&T shall pay for the loop to be restored to its original state.
- 3.9.2 Provisioning of High Frequency Spectrum and Splitter Space
- 3.9.2.1 BellSouth will provide AT&T with access to the High Frequency Spectrum as follows:
- 3.9.2.1.1 To order High Frequency Spectrum on a particular Loop, AT&T must have a Digital Subscriber Line Access Multiplexer (DSLAM) collocated in the central office that serves the end-user of such Loop. AT&T may order splitters in a central office once it has installed its DSLAM in that central office. BellSouth will install splitters within thirty-six (36) calendar days of AT&T's submission of such order to the BellSouth Complex Resale Support Group; provided, however, that in the event

BellSouth did not have reasonable notice that a particular central office was to have a splitter installed therein, the thirty-six (36) day interval shall not apply. Collocation itself or an application for collocation will serve as reasonable notice.

- 3.9.2.1.2 Once a splitter is installed on behalf of AT&T in a central office in which AT&T is located, AT&T shall be entitled to order the High Frequency Spectrum on lines served out of that central office. BellSouth will bill and AT&T shall pay the electronic or manual ordering charges as applicable when AT&T orders High Frequency Spectrum for end-user service.
- 3.9.2.1.3 BellSouth will select, purchase, install, and maintain a central office POTS splitter and provide AT&T access to data ports on the splitter. The splitter will route the High Frequency Spectrum on the circuit to AT&T's xDSL equipment in AT&T's collocation space. At least thirty (30) days before making a change in splitter suppliers, BellSouth will provide AT&T with a carrier notification letter, informing AT&T of change. AT&T shall purchase ports on the splitter in increments of 24 ports, and after July 25, 2001 AT&T can purchase ports on the splitter in increments of 8.
- 3.9.2.1.4 BellSouth will install the splitter in (i) a common area close to the AT&T collocation area, if possible; or (ii) in a BellSouth relay rack as close to the AT&T DS0 termination point as possible. AT&T shall have access to the splitter for test purposes, regardless of where the splitter is placed in the BellSouth premises. For purposes of this section, a common area is defined as an area in the central office in which both Parties have access to a common test access point. A Termination Point is defined as the point of termination for AT&T on the toll main distributing frame in the central office and is not the demarcation point set forth in Attachment 4 of this Agreement. BellSouth will cross-connect the splitter data ports to a specified AT&T DS0 at such time that a AT&T end user's service is established.
- 3.9.2.1.5 The High Frequency Spectrum shall only be available on loops on which BellSouth is also providing, and continues to provide, analog voice service directly to the end user. In the event the end-user terminates its BellSouth provided voice service for any reason, or in the event BellSouth disconnects the end user's voice service pursuant to its tariffs or applicable law, and AT&T desires to continue providing xDSL service on such loop, AT&T shall be required to purchase a full stand-alone loop unbundled network element. To the extent commercially practicable, BellSouth shall give AT&T notice in a reasonable time prior to disconnect, which notice shall give AT&T an adequate opportunity to notify BellSouth of its intent to purchase such

loop. In those cases in which BellSouth no longer provides voice service to the end user and AT&T purchases the full stand-alone loop, AT&T may elect the type of loop it will purchase. AT&T will pay the appropriate recurring and non-recurring rates for such loop as set forth in Exhibit A to this Attachment. In the event AT&T purchases a voice grade loop, AT&T acknowledges that such loop may not remain xDSL compatible.

- 3.9.2.1.6 Only one competitive local exchange carrier shall be permitted access to the High Frequency Spectrum of any particular loop.
- 3.9.2.2 Ordering
- 3.9.2.3 BellSouth will provide AT&T the Local Service Request (“LSR”) format to be used when ordering the High Frequency Spectrum.
- 3.9.2.3.1 BellSouth will return a manual Firm Order Confirmation (“FOC”) in no more than two (2) business days after receipt of a valid, error free manual LSR. When AT&T submits an electronic LSR for High Frequency Spectrum, BellSouth will return a FOC in four (4) hours ninety-five percent (95%) of the time, or, for orders that do not flow-through, in two (2) business days. BellSouth will provide AT&T with access to the High Frequency Spectrum at the following target intervals:
 - 3.9.2.3.2 For 1-5 lines at the same address within three (3) business days from BellSouth’s issuance of a FOC; 6-10 lines at same address within 5 business days from BellSouth’s issuance of a FOC; and more than 10 lines at the same address is to be negotiated.
 - 3.9.2.3.3 BellSouth will provide to AT&T BellSouth’s Loop Qualification System that BellSouth uses to qualify loops for its own ADSL offering.
 - 3.9.2.3.4 BellSouth will provide AT&T access to Preordering Loop Makeup (LMU), in accordance with the terms of this Agreement. BellSouth shall bill and AT&T shall pay the rates for such services, as described in Exhibit A.
 - 3.9.2.3.5 BellSouth shall test the data portion of the loop to ensure the continuity of the wiring for AT&T’s data.
- 3.9.2.4 Maintenance and Repair
 - 3.9.2.4.1 AT&T shall have access for repair and maintenance purposes, to any loop for which it has access to the High Frequency Spectrum. AT&T

may access the loop at the point where the combined voice and data signal exits the central office splitter.

- 3.9.2.4.2 BellSouth will be responsible for repairing voice services and the physical line between the network interface device at the customer's premises and the Termination Point. AT&T will be responsible for repairing data services. Each Party will be responsible for maintaining its own equipment.
- 3.9.2.4.3 AT&T shall inform its end users to direct data problems to AT&T, unless both voice and data services are impaired, in which event the end users should call BellSouth.
- 3.9.2.4.4 Once a Party has isolated a trouble to the other Party's portion of the loop, the Party isolating the trouble shall notify the end user that the trouble is on the other Party's portion of the loop.
- 3.9.2.4.5 In the event AT&T's deployment of xDSL on the High Frequency Spectrum significantly degrades the performance of other advanced services or of BellSouth's voice service on the same loop, BellSouth shall notify AT&T and allow twenty-four (24) hours to cure the trouble. If AT&T fails to resolve the trouble, BellSouth may discontinue AT&T's access to the High Frequency Spectrum on such loop.
- 3.9.2.5 Line Splitting. BellSouth will work cooperatively with CLECs to develop rates, methods and procedures to operationalize a process whereby two CLECs, one being a provider of voice services (a "Voice CLEC") and the other being a provider of data services (a "Data CLEC") may provide services over the same loop. The loop and port over which the services are provided cannot be a loop and port combination (i.e., UNE-P), but must be individual, stand alone network elements. The Voice CLEC or the Data CLEC shall be responsible for connecting the loop and port to a CLEC-owned splitter. BellSouth shall not own or maintain the splitter used for this purpose. When such rates, methods and procedures have been developed and operationalized, then at the request of AT&T, the Parties shall amend this Agreement to incorporate the same.

3.10 Integrated Digital Loop Carriers

- 3.10.1 If AT&T requests one or more loops served by an Integrated Digital Loop Carrier system ("IDLC"), BellSouth shall unbundle the IDLC-delivered loop, as soon as practicable, using one of the following alternative arrangements: (1) utilize existing Next Generation Digital Loop Carrier ("NGDLC") facilities; (2) utilize existing Universal Digital Loop Carrier ("UDLC"); (3) utilize existing cooper facilities that serve

the distribution area or allocate new copper feeder pairs to the distribution area if spare capacity is available in the feeder route or carrier serving area; (4) utilize spare capacity of existing Integrated Network Access system or other existing IDLC that is terminated on a digital cross-connect system; (5) utilize side-door/hairpin capability of switch peripheral if the serving IDLC is terminated on a peripheral with those capabilities, or if spare capacity is available on a switch peripheral; (6) activate new IDLC or NGDLC capacity to the distribution area; or (7) convert some existing IDLC capacity to UDL. These alternative arrangements will be used where available to permit AT&T to order a Loop and to provide AT&T with the capability to serve end users at the same level BellSouth provides its retail customers, to the extent technically feasible.

3.11 Loop Makeup (LMU)

3.11.1 Description of Service

3.11.1.1 BellSouth shall make available to AT&T loop makeup (LMU) information so that AT&T can make an independent judgment about whether the loop is capable of supporting the advanced services equipment AT&T intends to install and the services AT&T wishes to provide. This section addresses LMU as a *preordering* transaction, distinct from AT&T ordering any other service(s). Loop Makeup *Service Inquiries (LMUSI)* for *preordering loop makeup* are likewise unique from other preordering functions with associated service inquiries (SI) as described in this Agreement.

3.11.1.2 BellSouth will provide AT&T LMU information consisting of the composition of the loop material (copper/fiber); the existence, location and type of equipment on the loop, including but not limited to digital loop carrier or other remote concentration devices, feeder/distribution interfaces, bridged taps, load coils, pair-gain devices; the loop length; the wire gauge and electrical parameters.

3.11.1.3 BellSouth's LMU information is provided to AT&T as it exists either in BellSouth's databases or in its hard copy facility records. BellSouth does not guarantee accuracy or reliability of the LMU information provided.

3.11.1.4 AT&T may choose to use equipment that it deems will enable it to provide a certain type and level of service over a particular BellSouth loop. The determination shall be made solely by AT&T and BellSouth shall not be liable in any way for the performance of the advanced data services provisioned over said loop. The specific loop type (ADSL, HDSL, or otherwise) ordered on the LSR must match the LMU of the

loop requested taking into consideration any requisite line conditioning. The LMU data is provided for informational purposes only and does not guarantee AT&T's ability to provide advanced data services over the ordered loop type. Further, if AT&T orders loops that are not intended to support advanced services (such as UV-SL1, UV-SL2, or ISDN compatible loops) and that are not inventoried as advanced services loops, the LMU information for such loops is subject to change at any time due to modifications and/or upgrades to BellSouth's network. AT&T is fully responsible for any of its service configurations that may differ from BellSouth's technical standard for the loop type ordered.

- 3.11.1.5 Submitting Loop Makeup Service Inquiries AT&T may obtain LMU information by submitting a LMUSI mechanically or manually. Mechanized LMUSIs should be submitted through BellSouth's Operational Support Systems interfaces. After obtaining the loop from the mechanized LMUSI process, if AT&T needs further loop information in order to determine loop service capability, AT&T may initiate a separate Manual LMUSI for a separate nonrecurring charge as set forth in the rate exhibit for Attachment 2.
- 3.11.1.6 Manual LMUSIs shall be submitted by electronic mail to BellSouth's Complex Resale Support Group (CRSG)/Account Team utilizing the Preordering Loop Makeup Service Inquiry form. The service interval for the return of a Loop Makeup Manual Service Inquiry is seven business days. Manual LMUSIs are not subject to expedite requests. This service interval is distinct from the interval applied to the subsequent service order.
- 3.11.2 Loop Reservations
 - 3.11.2.1 AT&T may reserve facilities for up to four (4) calendar days for each facility requested on a LMUSI from the time the LMU information is returned to AT&T. During and prior to AT&T placing an LSR, the reserved facilities are rendered unavailable to other customers, including BellSouth. If AT&T does not submit an LSR for a UNE service on a reserved facility within the four-day reservation timeframe, the reservation of that spare facility will become invalid and the facility will be released.
 - 3.11.2.2 For a Mechanized LMUSI, AT&T may reserve up to ten loop facilities. For a Manual LMUSI, AT&T may reserve up to three loop facilities.
 - 3.11.2.3 Charges for preordering LMUSI are separate from any charges associated with ordering other services from BellSouth.
- 3.11.3 Ordering of Other UNE Services

3.11.3.1 All LSRs issued for reserved facilities shall reference the facility reservation number as provided by BellSouth. AT&T will not be billed any additional LMU charges for the loop ordered on such LSR. If, however, AT&T does not reserve facilities upon an initial LMUSI, AT&T's placement of an order for an advanced data service type facility shall be deemed placed for such a facility rate element that "includes manual service inquiry and reservation" per the rate matrix of this Attachment.

3.11.3.2 Where AT&T has reserved multiple loop facilities on a single reservation, AT&T may not specify which facility shall be provisioned when submitting the LSR. For those occasions, BellSouth will assign to AT&T, subject to availability, a facility that meets the BellSouth technical standards of the BellSouth type loop as ordered by AT&T. If the ordered loop type is not available, AT&T may utilize the Unbundled Loop Modification process or the Special Construction process, as applicable, to obtain the loop type ordered.

4 Network Interface Device ("NID")

4.1 Definition. The NID is defined as any means of interconnection of end user customer premises wiring to BellSouth's distribution plant, such as a cross-connect device used for that purpose. The NID is a single-line termination device or that portion of a multiple-line termination device required to terminate a single line or circuit at the end user's premises. The NID features two independent chambers or divisions that separate the service provider's network from the on-premises wiring. Each chamber or division contains the appropriate connection points or posts to which the service provider, and the end user each make their connections. The NID provides a protective ground connection and is capable of terminating cables such as twisted pair cable.

4.2 BellSouth shall permit AT&T to connect AT&T's loop facilities to on-premises wiring through BellSouth's NID or at any other technically feasible point.

4.3 Access to Network Interface Device

4.3.1 Due to the wide variety of NIDs utilized by BellSouth (based on subscriber size and environmental considerations), AT&T may access the subscriber's inside wire by any of the following means:

4.3.1.1 BellSouth shall allow AT&T to connect its loops directly to BellSouth's multi-line residential NID enclosures that have additional space and

are not used by BellSouth or any other telecommunications carriers to provide service to the premise.

- 4.3.1.2 Where an adequate length of on-premises wiring is present and environmental conditions permit, either Party may remove the on-premises wiring from the other Party's NID and connect that wire to that Party's own NID; or
- 4.3.1.3 Enter the subscriber access chamber or "side" of "dual chamber" NID enclosures for the purpose of extending a connecterized or spliced jumper wire from the on-premises wiring through a suitable "punch-out" hole of such NID enclosures; or
- 4.3.1.4 Request BellSouth to make other rearrangements to the on-premises wiring terminations or terminal enclosure on a time and materials cost basis to be charged to the requesting Party (i.e., AT&T, its agent, the building owner or the subscriber). Such charges will be billed to the requesting Party.
- 4.3.2 In no case shall either Party remove or disconnect the other Party's loop facilities from either Party's NIDs, enclosures, or protectors without adhering to state regulatory requirements and without providing prior notice to the other Party. In such cases, it shall be the responsibility of the Party disconnecting loop facilities to leave undisturbed the existing form of electrical protection (if applicable) and to maintain the physical integrity of the NID. The Party disconnecting the loop will hold BellSouth harmless for any liability associated with removal of the BellSouth loop from the BellSouth NID and the disconnecting Party will assume full liability for its actions and for any adverse consequences that may result. Furthermore, it shall be the responsibility of the disconnecting Party to reconnect the disconnected loop to a nationally-recognized-testing-laboratory-listed station protector which has been grounded as per Article 800 of the National Electrical Code within the NID. If no spare station protector exists in the NID, the disconnected loop must be appropriately cleared, capped and stored. If the disconnecting party does not wish to accept these responsibilities, other options exist in which BellSouth installs a NID as a chargeable option.
- 4.3.3 In no case shall either Party remove or disconnect ground wires from the other Party's NID, enclosures, or protectors.
- 4.3.4 In no case shall either Party remove or disconnect NID modules, protectors, or terminals from the other Party's NID enclosures.

- 4.3.5 Due to the wide variety of NID enclosures and outside plant environments BellSouth will work with AT&T to develop specific procedures to establish the most effective means of implementing this section.
- 4.3.6 Technical Requirements
- 4.3.6.1 The NID shall provide an accessible point of interconnection for the on-premise wiring, for BellSouth's facilities, for the Subloop Distribution and/or cross connect to AT&T's NID, and shall maintain a connection to ground.
- 4.3.6.2 The NID shall be capable of transferring electrical analog or digital signals between the on-premise wiring and the Subloop Distribution and/or cross connect to AT&T's NID, consistent with the NID's function at the Effective Date of this Agreement.
- 4.3.6.3 Where a BellSouth NID exists, it is provided in its "as is" condition. AT&T may request BellSouth do additional work to the NID at the time and materials charges set forth in the appropriate BellSouth Tariff.
- 4.3.6.4 When AT&T deploys its own local loops with respect to multiple-line termination devices, AT&T shall specify the quantity of NID connections it requires within such device.

5 Subloops Elements

- 5.1 Definitions
- 5.1.1 Subloop. The subloop network element is defined as any portion of the loop that is technically feasible to access at terminals in BellSouth's outside plant, including inside wire. An accessible terminal is any point on the loop where technicians can access the wire or fiber within the cable without removing a splice case to reach the wire or fiber within. Such points may include, but are not limited to, the pole or pedestal, the network interface device, ("NID") the minimum point of entry, ("MPOE") the single point of interconnection, the main distribution frame, the remote terminal, and the feeder/distribution interface ("FDI").
- 5.1.2 Inside Wire. Inside wire is defined as all loop plant owned by BellSouth on end user customer premises as far as the point of demarcation as defined in 47 C.F.R. § 68.3, including the loop plant near the end user customer premises. AT&T may access the inside wire subloop at any technically feasible point including, but not limited

to, the NID, the MPOE, the single point of interconnection, the pedestal, or the pole.

5.1.3 Subloop elements include, but are not limited to, the following: Distribution, including inside wire; Concentration Multiplexing Functionality; and Feeder.

5.3.1 Subloop Distribution

The Parties have agreed to move issues related to Subloop to the Kentucky Public Service Commissions Administrative Docket 382. Consistent with the Commission's Order in this Docket, the Parties agree to amend this Agreement within sixty (60) days of the Commission's resolution of exceptions and any Motion for Reconsideration filed by the Parties. For purposes of this Agreement, the Parties agree to the following:

5.1.3.1.1 The unbundled subloop distribution facility is a dedicated transmission facility that BellSouth provides from an end user's point of demarcation to a BellSouth cross-connect device. The BellSouth cross-connect device may be located within a remote terminal (RT) or a stand-alone cross-box in the field or in the equipment room of a building. The unbundled sub-loop distribution media is a copper twisted pair that can be provisioned as a 2 Wire or 4 Wire facility. BellSouth will make the following available sub-loop distribution offerings where facilities permit:

Unbundled SubLoop Distribution – Voice Grade
Unbundled Copper Sub-Loop
Unbundled SubLoop Distribution – Intrabuilding Network Cable
(aka riser cable)

5.1.3.1.2 Unbundled SubLoop Distribution – Voice Grade (“USLD-VG”) is a subloop facility from the cross-box in the field up to and including the point of demarcation, at the end user's premises and may have load coils.

5.1.3.1.3 Unbundled Copper SubLoop (“UCSL”) is a copper facility of any length provided from the cross-box in the field up to and including the end-user's point of demarcation. If available, this facility will not have any intervening equipment such as load coils between the end-user and the cross-box.

5.1.3.1.4 If AT&T requests a UCSL and it is not available, AT&T may request the SubLoop facility be modified pursuant to the ULM process request to remove load coils and/or bridged taps. If load coils and/or bridged taps are removed, the facility will be classified as a UCSL.

- 5.1.3.1.5 Unbundled SubLoop Distribution – Intrabuilding Network Cable (“USLD-INC”) is the distribution facility inside a building or between buildings on the same continuous property which is not separated by a public street or road. USLD-INC includes the facility from the cross-connect device in the building equipment room up to and including the point of demarcation, at the end user’s premises.
- 5.1.3.1.6 BellSouth will install a cross connect panel in the building equipment room for the purpose of accessing USLD-INC pairs from a building equipment room. The cross-connect panel will function as a single point of interconnection (“SPOI”) for USLD-INC and will be accessible by multiple carriers as space permits. BellSouth will place cross-connect blocks in 25-pair increments for AT&T’s use on this cross-connect panel. AT&T will be responsible for connecting its facilities to the 25-pair cross-connect block(s).
- 5.1.3.1.7 Unbundled SubLoop distribution facilities shall support functions associated with provisioning, maintenance and testing of the Unbundled SubLoop. For access to Voice Grade USLD and UCSSL, AT&T shall install a cable to the BellSouth cross-box pursuant to the terms and conditions for physical collocation for remote sites set forth in this Agreement. This cable would be connected by a BellSouth technician within the BellSouth cross-box during the set-up process. AT&T’s cable pairs can then be connected to BellSouth’s USL within the BellSouth cross-box by the BellSouth technician.
- 5.1.3.1.8 Through the Service Inquiry (“SI”) process, BellSouth will determine whether access to Unbundled SubLoops at the location requested by AT&T is technically feasible and whether sufficient capacity exists in the cross-box. If existing capacity is sufficient to meet AT&T’s request, then BellSouth will perform the site set-up as described in this Section. If any work must be done to modify existing BellSouth facilities or add new facilities (other than adding the cross-connect panel in a building equipment room as noted in this Section) to accommodate AT&T’s request for Unbundled SubLoops, AT&T may request BellSouth’s Special Construction (“SC”) process to determine additional costs required to provision the Unbundled SubLoops. AT&T will have the option to proceed under the SC process to modify the BellSouth facilities.
- 5.1.3.1.8 The site set-up must be completed before AT&T can order sub-loop pairs. For the site set-up in a BellSouth cross-connect box in the field, BellSouth will perform the necessary work to splice AT&T’s cable into the cross-connect box. For the site set-up inside a building equipment room, BellSouth will perform the necessary work to install the cross-

connect panel and the connecting block(s) that will be used to provide access to the requested USLs.

5.1.3.1.9 Once the site set-up is complete, AT&T will request sub-loop pairs through submission of a Local Service Request (“LSR”) form to the Local Carrier Service Center (“LCSC”). Order Coordination is required with USL pair provisioning when AT&T requests reuse of an existing facility and is in addition to the USL pair rate. For expedite requests by AT&T for sub-loop pairs, expedite charges will apply for intervals less than 5 days.

5.1.3.1.10 Unbundled SubLoops will be provided in accordance with technical reference TR73600.

5.1.4 Unbundled Network Terminating Wire (“UNTW”)

5.1.4.1 Unbundled Network Terminating Wire (“UNTW”) is unshielded twisted copper wiring that is used to extend circuits from an intra-building network cable terminal or from a building entrance terminal to an individual customer’s point of demarcation. It is the final portion of the Loop which, in multi-subscriber configurations, represents the point at which the network branches out to serve individual subscribers.

5.1.4.2 This element will be provided in Multi-Dwelling Units (“MDUs”) and/or Multi-Tenants Units (“MTUs”) where BellSouth owns wiring all the way to the end-users premises. BellSouth will not provide this element in those locations where the property owner provides its own wiring to the end-user’s premises, where a third party owns the wiring to the end-user’s premises or where the property owner will not allow BellSouth to place its facilities to the end user.

5.1.4.3 Requirements

5.1.4.3.1 On a multi-unit premises, upon request of the other Party (“Requesting Party”), the Party owning the network terminating wire will provide access to UNTW pairs on an Access Terminal that is suitable for use by multiple carriers at each Garden Terminal or Wiring Closet.

5.1.4.3.2 The Provisioning Party shall not be required to install new or additional NTW beyond existing NTW to provision the services of the Requesting Party.

5.1.4.3.3 Upon receipt of the UNTW (SI) requesting access to the Provisioning Party’s UNTW pairs at a multi-unit premises, representatives of both Parties will participate in a meeting at the site of the requested access. The purpose of the site visit will include discussion of the procedures

for installation and location of the Access Terminals. By request of the Requesting Party, an Access Terminal will be installed either adjacent to each Provisioning Party's Garden Terminal or inside each Wiring Closet. Requesting Party will deliver and connect its central office facilities to the UNTW pairs within the Access Terminal. Requesting Party may access any available pair on an Access Terminal. A pair is available when a pair is not being utilized to provide service or where the end user has requested a change in its local service provider to the Requesting Party. Prior to connecting Requesting Party's service on a pair previously used by Provisioning Party, Requesting Party is responsible for ensuring the end-user is no longer using Provisioning Party's service or another CLEC's service before accessing UNTW pairs.

- 5.1.4.3.4 Access Terminal installation intervals will be established on an individual case basis.
- 5.1.4.3.5 Requesting Party is responsible for obtaining the property owner's permission for Provisioning Party to install an Access Terminal(s) on behalf of the Requesting Party. The submission of the SI by the Requesting Party will serve as certification by the Requesting Party that such permission has been obtained. If the property owner objects to Access Terminal installations that are in progress or subsequent to completion and demands removal of Access Terminals, Requesting Party will be responsible for costs associated with removing Access Terminals and restoring property to its original state prior to Access Terminals being installed.
- 5.1.4.3.6 The Requesting Party shall indemnify and hold harmless the Provisioning Party against any claims of any kind that may arise out of the Requesting Party's failure to obtain the property owner's permission. Requesting Party will be billed for non-recurring and recurring charges for accessing UNTW pairs at the time the Requesting Party activates the pair(s). The Requesting Party will notify the Provisioning Party each time it activates UNTW pairs using the LSR form.
- 5.1.4.3.7 Requesting Party will isolate and report troubles in the manner specified by the Provisioning Party. Requesting Party must tag the UNTW pair that requires repair. If Provisioning Party dispatches a technician on a reported trouble call and no UNTW trouble is found, Provisioning Party will charge Requesting Party for time spent on the dispatch and testing the UNTW pair(s).
- 5.1.4.3.8 If Requesting Party initiates the Access Terminal installation and the Requesting Party has not activated at least one pair on the Access

Terminal installed pursuant to Requesting Party's request for an Access Terminal within 6 months of installation of the Access Terminal, Provisioning Party will bill Requesting Party a non-recurring charge equal to the actual cost of provisioning the Access Terminal.

- 5.1.4.3.9 If Provisioning Party determines that Requesting Party is using the UNTW pairs without reporting the activation of the pairs, the following charges shall apply:
- 5.1.4.3.10 If Requesting Party issued a LSR to disconnect an end-user from Provisioning Party in order to use a UNTW pair, Requesting Party will be billed for the use of the pair back to the disconnect order date.
- 5.1.4.3.11 If Requesting Party activated a UNTW pair on which Provisioning Party was not previously providing service, Requesting Party will be billed for the use of that pair back to the date the end-user began receiving service using that pair. Upon request, Requesting Party will provide copies of its billing record to substantiate such date. If Requesting Party fails to provide such records, then Provisioning Party will bill the Requesting Party back to the date of the Access Terminal installation.

5.1.5 Subloop Concentration Multiplexing Functionality

- 5.1.5.1 Where facilities permit, BellSouth will provide to AT&T the ability to concentrate its subloops onto multiple DS1s back to the BellSouth central office.
- 5.1.5.2 Definition
 - 5.1.5.2.1 The Subloop Concentration Multiplexing Functionality: (1) aggregates lower bit rate or bandwidth signals to higher bit rate or bandwidth signals (multiplexing); (2) disaggregates higher bit rate or bandwidth signals to lower bit rate or bandwidth signals (demultiplexing); (3) aggregates a specified number of signals or channels to fewer channels (concentrating); (4) performs signal conversion, including encoding of signals (e.g., analog to digital and digital to analog signal conversion); and (5) where available, performs electrical to optical (E/O) conversion.
 - 5.2.5.2.2 The Subloop Concentration Multiplexing Functionality may be provided through a Digital Loop Carrier ("DLC") system, multiplexer or other equipment at which traffic is encoded and decoded, multiplexed and demultiplexed, or concentrated.
- 5.1.5.3 Technical Requirements

- 5.1.5.3.1 The Subloop Concentration Multiplexing Functionality, if deployed, is used to concentrate and or multiplex the AT&T distribution media to the BellSouth feeder media. BellSouth's feeder media can be copper, coaxial (if deployed) or fiber. To the extent unbundling involves "concentration," BellSouth and AT&T will work cooperatively to establish concentration ratios for the specific application within the technical limits that may exist with deployed equipment and facilities. If concentration ratios are established which result in reengineering of the facilities, special construction charges will apply.
- 5.1.5.3.2 When BellSouth provides a Subloop Concentration Multiplexing Functionality or Loop repeaters, BellSouth shall provide power for subloop equipment through a non-interruptible source with battery backup unless otherwise mutually agreed upon by the Parties.
- 5.1.5.3.3 The Subloop Concentration Multiplexing Functionality shall be provided to AT&T in accordance with applicable industry standard technical references.
- 5.1.5.3.4 The Subloop Concentration Multiplexing Functionality shall continuously monitor protected circuit packs and redundant common equipment in the same manner which BellSouth provides such functionality to itself.
- 5.1.5.3.5 The redundant common equipment shall also automatically switch to a protection circuit pack on detection of a failure or degradation of normal operation where technically feasible.
- 5.1.5.3.6 The Subloop Concentration Multiplexing Functionality shall be capable of performing its functions on the signals needed to provide telecommunications services capable of being transmitted through said Subloop Concentration Multiplexing Functionality.
- 5.1.5.3.7 BellSouth shall provide power for the Subloop Concentration Multiplexing Functionality, through a non-interruptible source if the function is performed in a central office, or from a commercial AC power source with battery backup if the equipment is located outside a central office, where BellSouth provides such functionality to itself.
- 5.1.5.3.8 With the Effective Date of this Agreement, Subloop Concentration Multiplexing Functionality, using the Lucent Series 5 equipment, will be offered in two different systems. System A will allow up to 96 of AT&T's subloops to be concentrated onto multiple DS1s. System B will allow an additional 96 of AT&T's subloops to be concentrated onto multiple DS1s. One System A may be supplemented with one System B and they both must be physically located in a single Series 5 dual

channel bank. A minimum of two DS1s is required for each system (i.e., System A requires two DS1s and System B would require an additional two DS1s or four in total). The DS1 level facility that connects the RT site with the BSWC is known as a feeder interface. Except where the Subloop Concentration Multiplexing Functionality is currently combined with other Network Elements. All DS1 Feeder Interfaces will terminate to AT&T's Collocation Space within the BSWC that serves the RT where AT&T's subloops are connected. Subloop Concentration Multiplexing Functionality service is offered with or without concentration and with or without a protection DS1. If BellSouth deploys a different technology for Subloop Concentration Multiplexing Functionality in its network, the Parties will negotiate rates, terms and conditions for AT&T's access to such Subloop Concentration Multiplexing Functionality.

- 5.1.5.3.9 If technically feasible, BellSouth shall provide AT&T access to the Subloop Concentration Multiplexing Functionality in response to a specific AT&T request. Otherwise, AT&T would be required to place a cross-box, remote terminal, or other similar device and deliver a cable to the BellSouth remote terminal. This cable would be connected, by a BellSouth technician, to a cross-connect panel within the BellSouth RT/cross-box and would allow AT&T's subloops to then be placed on the Subloop Concentration Multiplexing Functionality.
- 5.1.5.3.10 The Subloop Concentration Multiplexing Functionality shall be provided to AT&T in accordance with applicable industry standard technical references.
- 5.1.5.3.11 BellSouth shall provide AT&T real time performance and alarm data that may affect AT&T's traffic, if and when technically feasible and to partition such data for AT&T where feasible.
- 5.1.5.3.12 At AT&T's option BellSouth shall provide AT&T with real time ability to initiate non service-affecting tests on the underlying device that provides Subloop Concentration Multiplexing Functionality.

5.1.6 Subloop Feeder

5.1.6.1 Definition

- 5.1.6.1.1 The Subloop Feeder is the Network Element that provides connectivity between (1) a FDI associated with Subloop Distribution and a termination point appropriate for the media in a central office, or (2) a Subloop Concentration Multiplexing Functionality provided in a remote terminal and a termination point appropriate for the media in a central office. If technically feasible, BellSouth shall provide AT&T physical

access to the FDI, and the right to connect the Subloop Feeder to the FDI in response to a specific AT&T request. Otherwise, BellSouth shall provide the necessary cabling between BellSouth's equipment (i.e., FDI) and AT&T's equipment.

- 5.1.6.1.2 The physical medium of the Subloop Feeder may be copper twisted pair, coaxial (if deployed), or single or multi-mode fiber. In certain cases, BellSouth must provide a copper twisted pair loop even in instances where the medium of the Subloop Feeder for services that BellSouth offers is other than a copper facility, and in such cases, the special construction process will be used to determine the cost of placing new copper facilities.
- 5.1.6.2 Requirements for Subloop Feeder
 - 5.1.6.2.1 The Subloop Feeder shall be capable of transmitting analog voice frequency, basic rate ISDN, digital data, or analog radio frequency signals, where available in BellSouth's network.
 - 5.1.6.2.2 BellSouth shall provide appropriate power for all active elements in the Subloop Feeder. BellSouth will provide appropriate power from a central office source, or from a commercial AC source with rectifiers for AC to DC conversion and 8-hour battery back-up when the equipment is located in an outside plant RT, where BellSouth provides such functionality to itself.
- 5.1.6.3 Additional Requirements for Special Copper Subloop Feeder Medium
 - 5.1.6.3.1 In addition to requirements set forth in Section 5.1.6.2 above, and where available in the BellSouth network, AT&T may require BellSouth to provide copper twisted pair Subloop Feeder which are unfettered by any intervening equipment (e.g. filters, load coils, and range extenders), so that AT&T can use these Subloop Feeders for a variety of services by attaching appropriate terminal equipment at the ends.
- 5.1.6.4 Additional Technical Requirements for DS1 Conditioned Subloop Feeder
 - 5.1.6.4.1 In addition to the requirements set forth in this Section and where available in the BellSouth network, AT&T may designate that the Subloop Feeder be conditioned to transport a DS1 signal. The requirements for such transport are defined in the applicable industry standard technical references.
- 5.1.6.5 Additional Technical Requirements for Optical Subloop Feeder

- 5.1.6.5.1 Where available in BellSouth's network AT&T may designate that Subloop Feeder will transport DS3 and OCn (where n is defined in the industry standard technical reference). The requirements for such transport are defined in the applicable industry standard technical references.
- 5.1.6.6 Interface Requirements
- 5.1.6.6.1 If AT&T desires access to unbundled Subloop Feeder in a BellSouth Central Offices, the Subloop Feeder point of termination ("POT") will be as follows:
 - 5.1.6.6.1.1 Copper twisted pairs shall terminate on the MDF;
 - 5.1.6.6.1.2 DS1 Subloop Feeder shall terminate on a DSX1, DCS1/0 or DCS3/1; and
 - 5.1.6.6.1.3 Fiber Optic cable shall terminate on a LGX.

6 Switching Capabilities

- 6.1 BellSouth shall provide non-discriminatory access to local circuit switching capability, and local tandem switching capability, on an unbundled basis, except as set forth below in Section 6.3 of this Attachment 2, to AT&T for the provision of a telecommunications service. BellSouth shall provide non-discriminatory access to packet switching capability on an unbundled basis to AT&T for the provision of a telecommunications service only in the limited circumstance.
- 6.2 Except as otherwise provided for herein, BellSouth shall not impose any restrictions on AT&T regarding the use of Switching Capabilities purchased from BellSouth provided such use does not result in demonstrable harm to either the BellSouth network or personnel or the use of BellSouth's network by BellSouth or any other telecommunications carrier.
- 6.3 Local Circuit Switching Capability, including Tandem Switching Capability.
 - 6.3.1 Definition
 - 6.3.1.1 Local Circuit Switching capability is defined as: (A) line-side facilities, which, include but are not limited to, the connection between a loop termination at a main distribution frame and a switch line card; (B) trunk-side facilities, which include, but are not limited to, the connection between trunk termination at a trunk-side cross-connect panel and a switch trunk card; (C) All features, functions, and capabilities of the

switch, which include, but are not limited to: (1) the basic switching function of connecting lines to lines, line to trunks, trunks to lines, and trunks to trunks, as well as the same basic capabilities made available to BellSouth's end users, such as a telephone number, white page listings, and dial tone; and (2) all other features that the switch is capable of providing, including but not limited to, customer calling, custom local area signaling service features, and Centrex, as well as any technically feasible customized routing functions provided by the switch; and (D) switching provided by remote switching module functionality is included in Switching Capability. The switching capabilities used will be based on the line side features they support.

- 6.3.1.2 Notwithstanding BellSouth's general duty to unbundle local circuit switching, BellSouth shall not be required to unbundle local circuit switching for AT&T when AT&T serves end users with four (4) or more voice-grade (DS-0) equivalents or lines in locations served by BellSouth's local circuit switches, which are in the following MSAs: Atlanta, GA; Miami, FL; Orlando, FL; Ft. Lauderdale, FL; Charlotte-Gastonia-Rock Hill, NC; Greensboro/Winston-Salem/High Point, NC; Nashville, TN; and New Orleans, LA, and BellSouth has provided non-discriminatory cost based access to the Enhanced Extended Link ("EEL") throughout Density Zone 1 as determined by NECA Tariff No. 4 as in effect on January 1, 1999.
- 6.3.1.2.1 In the event that AT&T orders local circuit switching for a single end user account name at a single physical end user location with four (4) or more 2-wire voice-grade loops from a BellSouth central office in an MSA listed above, BellSouth shall charge AT&T the market based rate in Exhibit A for use of the local circuit switching functionality for the affected facilities.
- 6.3.1.3 When BellSouth provides the local circuit switching, BellSouth will provide to AT&T, upon request, customized routing (selective routing) of calls: (i) to a requested directory assistance services platform; (ii) to a requested operator services platform; (iii) for AT&T's PIC'ed toll traffic in a two (2) PIC environment to an alternative OS/DA platform designated by AT&T or (iv) to a repair center. AT&T end users may use the same dialing arrangements as BellSouth end users. BellSouth shall allow AT&T to commingle local and toll OS and/or DA traffic on existing OS and/or FGD trunks. Customized routing will include but not be limited to the customized routing of inter-switch traffic (i.e. between one or more of BellSouth's, AT&T's or Third's switch) on a wire center NPA-NXX basis to a port other than the standard routing used by BellSouth.

6.4 AIN Customized (Selective) Carrier Routing

- 6.4.1 BellSouth will provide AIN customized carrier routing at the request of AT&T. AIN customized carrier routing will provide AT&T with the capability of routing operator calls, 0+ and 0- and 0+ NPA (LNPA) 555-1212 directory assistance, 1+411 directory assistance and 611 repair center calls, to pre-selected destinations.
- 6.4.2 AT&T shall order AIN customized carrier routing through its Account Team. AIN customized carrier routing must first be established regionally and then on a per central office, per state basis.
- 6.4.3 AIN customized carrier routing is not available in DMS 10 switches.
- 6.4.4 Where AIN customized carrier routing is utilized by AT&T, the routing of AT&T's end user calls shall be pursuant to information provided by AT&T and stored in BellSouth's AIN customized carrier routing service control point database. AIN customized carrier routing shall utilize a set of line class codes ("LCCs") unique to a basic class of service assigned on an "as needed" basis. The same LCCs will be assigned in each central office where AIN customized carrier routing is established.
- 6.4.5 Upon ordering of AIN customized carrier routing regional service, AT&T shall remit to BellSouth the regional service order non-recurring charges set forth in Exhibit A of this Attachment, incorporated herein by this reference. There shall be a non-recurring end office establishment charge per office due at the addition of each central office where AIN customized carrier routing will be utilized. Said non-recurring charge shall be as set forth in Exhibit A of this Attachment, incorporated herein by this reference. For each AT&T end user activated, there shall be a non-recurring end user establishment charge as set forth in Exhibit A of this Attachment, payable to BellSouth pursuant to the terms of this Section 6.4, incorporated herein by this reference. AT&T shall pay the AIN customized carrier routing per query charge set forth in Exhibit A of this Attachment, incorporated herein by this reference.
- 6.4.6 The regional service order non-recurring charge will be non-refundable and will be paid with 1/2 coming up-front with the submission of all fully completed required forms, including: Regional Customized Carrier Routing Order Request-Form A, Central Office AIN Customized Carrier Routing Order Request-Form B, AIN_SCR Central Office Identification Form-Form C, AIN_SCR Routing Options Selection Form-Form D, and Routing Combinations Table-Form E. BellSouth has thirty (30) days to respond to the client's fully completed firm order as a regional service order. With the delivery of this firm order response to AT&T, BellSouth considers that the delivery schedule of this service commences. The remaining 1/2 of the regional service order payment must be paid

when at least 90% of the central offices listed on the original order have been turned up for the service.

- 6.4.7 The non-recurring end office establishment charge will be billed to AT&T following BellSouth's normal monthly billing cycle for this type of order.
- 6.4.8 End user establishment orders will not be turned-up until the second payment is received for the regional service order. The non-recurring end user establishment charges will be billed to AT&T following BellSouth's normal monthly billing cycle for this type of order.
- 6.4.9 Additionally, the AIN customized carrier routing per query charge will be billed to AT&T following the normal billing cycle for per query charges.
- 6.4.10 All other network components needed, for example, unbundled switching and unbundled local transport, etc., will be billed accordingly per contracted rates.
- 6.5 Technical Requirements
 - 6.5.1 Local Switching shall be at least equal to the requirements for Local Switching set forth in the applicable industry standard technical references.
 - 6.5.2 BellSouth's local switch shall maintain translations necessary to direct AIN queries for selected lines and dialing sequences to the AT&T Signaling System 7 ("SS7") network.
 - 6.5.3 BellSouth's local switch shall accept mutually agreeable AIN responses from the AT&T Service Control Point ("SCP") via SS7 network interconnection then continue call handling according to instructions contained in the response.
 - 6.5.4 BellSouth shall provide unbranded recorded announcements and call progress tones to alert callers of call progress and disposition.
 - 6.5.5 BellSouth shall activate service for an AT&T end user or network interconnection on any of the local circuit switching interfaces. This includes provisioning changes to change an end user from BellSouth's services to AT&T's services without loss of switch feature functionality as defined in this Agreement.
 - 6.5.6 BellSouth shall perform routine testing (e.g., Mechanized Loop Tests ("MLT") and test calls such as 105, 107 and 108 type calls) and fault isolation on a mutually agreed upon schedule.

- 6.5.7 BellSouth shall repair and restore any equipment or any other maintainable component that may adversely impact local circuit switching.
- 6.5.8 BellSouth shall control congestion points such as those caused by radio station call-ins, and network routing abnormalities. All traffic shall be restricted in a non-discriminatory manner.
- 6.5.9 BellSouth shall perform manual call trace and permit end user originated call trace.
- 6.5.10 For local switching used as 911 Tandems, BellSouth shall allow interconnection from AT&T local switching elements and BellSouth shall route the calls to the appropriate Public Safety Access Point ("PSAP").
- 6.5.11 Special Services provided by BellSouth will include the following:
 - 6.5.11.1 Essential service lines;
 - 6.5.11.2 Telephone Service Prioritization;
 - 6.5.11.3 Related services for handicapped;
 - 6.5.11.4 Soft dial tone where required by law; and
 - 6.5.11.5 Any other service required by law.
- 6.5.12 BellSouth shall provide Switching Service Point ("SSP") capabilities and signaling software to interconnect the signaling links destined to the Signaling Transfer Point Switch ("STPS"). These capabilities shall adhere to the technical specifications set forth in the applicable industry standard technical references.
- 6.5.13 BellSouth shall provide interfaces to adjuncts in accordance with the technical specifications set forth in the applicable industry standard technical references. These adjuncts can include, but are not limited to, the Service Circuit Node and Automatic Call Distributors.
- 6.5.14 BellSouth shall provide performance data regarding an end user line, traffic characteristics or other measurable elements to AT&T, upon a reasonable request from AT&T. AT&T will pay BellSouth for all costs incurred to provide such performance data through the process set forth in Section 13 of the General Terms and Conditions of this Agreement, incorporated herein by this reference.

- 6.5.15 BellSouth shall offer to AT&T all AIN triggers which are supported by BellSouth for offering AIN-based services in accordance with the technical specifications set forth in the applicable industry standard technical references. Triggers that are currently available include:
 - 6.5.15.1 Off-Hook Immediate,
 - 6.5.15.2 Off-Hook Delay,
 - 6.5.15.3 Termination Attempt,
 - 6.5.15.4 3/6/10 Public Office Dialing Plan,
 - 6.5.15.5 Feature Code Dialing,
 - 6.5.15.6 Customer Dialing Plan.
 - 6.5.16 When additional triggers are supported by BellSouth, BellSouth will make these triggers available to AT&T:
 - 6.5.16.1 Private EAMF Trunk,
 - 6.5.16.2 Shared Interoffice Trunk (EAMF, SS7),
 - 6.5.16.3 N11,
 - 6.5.16.4 Automatic Route Selection.
 - 6.5.17 If an AT&T end user subscribes to AT&T provided voice mail and messaging services, BellSouth shall redirect incoming calls to the AT&T system based upon presubscribed service arrangements (e.g., busy, don't answer, number of rings) through dedicated trunks provided by AT&T. In addition, BellSouth shall provide a Standard Message Desk Interface-Enhanced ("SMDI-E") interface to the AT&T system. BellSouth shall support the Inter-switch Voice Messaging Service ("IVMS") capability.
- 6.6 Tandem Switching**
- 6.6.1 Definition
 - 6.6.1.1 The Tandem Switching Capability is defined as:
 - 6.6.1.1.1 Trunk-connect facilities, which include, but are not limited to, the connection between trunk termination at a cross connect panel and switch trunk card;

- 6.6.1.1.2 The basic switch trunk function of connecting trunks to trunks; and
- 6.6.1.1.3 The functions that are centralized in tandem switches (as distinguished from separate end office switches), including but not limited, to call recording, the routing of calls to operator services, and signaling conversion features.
- 6.6.1.2 BellSouth shall perform routine testing and fault isolation on the underlying switch that is providing Tandem Switching and all its interconnections. When requested by AT&T, the results and reports of the testing shall be made immediately available to AT&T.
- 6.6.1.3 BellSouth shall maintain AT&T's trunks and interconnections associated with Tandem Switching at least at parity to its own trunks and interconnections.
- 6.6.1.4 BellSouth shall control congestion points and network abnormalities. Congestion control provided or imposed on AT&T traffic shall be at parity with controls being provided or imposed on BellSouth traffic (e.g., BellSouth shall not block AT&T traffic and leave its traffic unaffected or less affected).
- 6.6.1.5 Tandem Switching shall process originating toll-free traffic received from an AT&T local switch.
- 6.6.1.6 In support of AIN triggers and features, Tandem Switching shall provide SSP capabilities when these capabilities are not available from the Local Switching Network Element, to the extent such Tandem Switch has such capability.
- 6.6.1.7 The Local Switching and Tandem Switching functions may be combined in an office. If this is done, both Local Switching and Tandem switching shall provide all of the functionality required of each of those Network Elements in this Agreement.

6.7 Interface Requirements

- 6.7.1 Tandem Switching shall provide interconnection to the E911 PSAP where the underlying Tandem is acting as the E911 Tandem.
- 6.7.2 Tandem Switching shall interconnect, with direct trunks, to all carriers with which BellSouth interconnects.
- 6.7.3 BellSouth shall provide all signaling necessary to provide Tandem Switching with no loss of feature functionality.

6.7.4 Tandem Switching shall interconnect with AT&T's switch, using two-way trunks, for traffic that is transiting via BellSouth network to interLATA or intraLATA carriers. At AT&T's request, Tandem Switching shall record and keep records of traffic for billing.

7 Operator Call Processing, Inward Operator Services and Directory Assistance Services

7.1 All of the negotiated rates, terms and conditions set forth in this Section pertain to the provision of Operator Call Processing, Inward Operator Services and Directory Assistance Services.

7.1.1 Operator Systems

7.1.1.1 Definition. Operator Systems is the Network Element that provides operator and automated call handling and billing, special services, end user telephone listings and optional call completion services. The Operator Systems, Network Element provides two types of functions: Operator Service functions and Directory Assistance Service functions, each of which are described in detail below.

7.2 Operator Service

7.2.1 Definition. Operator Service provides: (1) operator handling for call completion (for example, collect, third number billing, and manual calling-card calls), (2) operator or automated assistance for billing after the end user has dialed the called number (for example, calling card calls); and (3) special services including but not limited to Busy Line Verification and Emergency Line Interrupt (ELI), Emergency Agency Call, Operator-assisted Directory Assistance, and Rate Quotes.

7.2.2 Requirements

7.2.2.1 When AT&T requests BellSouth to provide Operator Services, the following requirements apply:

7.2.2.1.1 BellSouth shall complete 0+ and 0- dialed local calls.

7.2.2.1.2 BellSouth shall complete 0+ and 0- intraLATA toll calls.

7.2.2.1.3 BellSouth shall process calls that are billed to AT&T end user's calling card that can be validated by BellSouth.

7.2.2.1.4 BellSouth shall complete person-to-person calls.

7.2.2.1.5 BellSouth shall complete collect calls.

- 7.2.2.1.6 BellSouth shall provide the capability for callers to bill to a third party and complete such calls.
- 7.2.2.1.7 BellSouth shall complete station-to-station calls.
- 7.2.2.1.8 BellSouth shall process emergency calls.
- 7.2.2.1.9 BellSouth shall process Busy Line Verify and Emergency Line Interrupt requests.
- 7.2.2.1.10 BellSouth shall process emergency call trace, as it does for its own end users prior to the Effective Date. Call must originate from a 911 provider.
- 7.2.2.1.11 BellSouth shall process operator-assisted directory assistance calls.
- 7.2.2.1.12 BellSouth shall adhere to equal access requirements, providing AT&T local end users the same IXC access as provided to BellSouth end users.
- 7.2.2.1.13 BellSouth shall exercise at least the same level of fraud control in providing Operator Service to AT&T that BellSouth provides for its own operator service.
- 7.2.2.1.14 BellSouth shall perform Billed Number Screening when handling Collect, Person-to-Person, and Billed-to-Third-Party calls.
- 7.2.2.1.15 BellSouth shall direct customer account and other similar inquiries to the customer service center designated by AT&T.
- 7.2.2.1.16 BellSouth shall provide a feed of customer call records in "EMI" format to AT&T in accordance with AT&T ODUF standards specified in Attachment 7.

7.2.2.2 Interface Requirements

- 7.2.2.2.1 With respect to Operator Services for calls that originate on local switching capability provided by or on behalf of AT&T, the interface requirements shall conform to the then current established system interface specifications for the platform used to provide Operator Service and the interface shall conform to industry standards.

7.3 Directory Assistance Service

- 7.3.1 Definition. Directory Assistance Service provides local end user telephone number listings with the option to complete the call at the caller's direction separate and distinct from local switching.

7.3.2 Requirements

Directory Assistance Service shall provide up to two listing requests per call. If available and if requested by AT&T's end user, BellSouth shall provide caller-optional directory assistance call completion service at rates contained in this Attachment to one of the provided listings, equal to that which BellSouth provides its end users. If not available, AT&T may request such requirement pursuant to the BFR/NBR Process as set forth in General Terms and Conditions.

7.3.3 Directory Assistance Service Updates

BellSouth shall update end user listings changes daily via the Directory Assistance Database . These changes include:

7.3.3.1 New end user connections: BellSouth will provide service to AT&T that is equal to the service it provides to itself and its end users;

7.3.3.1.2 End user disconnections: BellSouth will provide service to AT&T that is equal to the service it provides to itself and its end users; and

7.3.3.1.3 End user address changes: BellSouth will provide service to AT&T that is equal to the service it provides to itself and its end users;

7.3.3.1.4 These updates shall also be provided for non-listed and non-published numbers for use in emergencies.

7.4 Branding for Operator Call Processing and Directory Assistance

7.4.1 The BellSouth Operator Systems Branding Feature provides a definable announcement to AT&T end users using Directory Assistance ("DA")/Operator Call Processing ("OCP") prior to placing such end users in queue or connecting them to an available operator or automated operator system. This feature allows AT&T to have its calls custom branded with AT&T's name on whose behalf BellSouth is providing Directory Assistance and/or Operator Call Processing. Rates for Custom Branding, Operator Call Process and Directory Assistance are set forth in this Attachment.

7.4.2 BellSouth offers three (3) service levels of branding to AT&T when ordering BellSouth's Directory Assistance and/or Operator Call Processing.

7.4.2.1 Service Level 1 - BellSouth Branding

7.4.2.2 Service Level 2 - Unbranding

7.4.2.3 Service Level 3 - Custom Branding

- 7.4.3 Where AT&T resells BellSouth's services or purchases unbundled local switching from BellSouth, BellSouth will provide Self Branding to AT&T upon request, whereby, through Selective Carrier Routing, BellSouth will route AT&T's end user calls to a directory assistance provider and/or operator services provider other than BellSouth. BellSouth offers Self Branding as described in Section 7.5.2.8 below.
- 7.4.4 For Resellers and Use with an Unbundled Port
- 7.4.4.1 BellSouth Branding is the Default Service Level.
- 7.5 In order for BellSouth to provide Custom Branding or Unbranding for Operator Services and/or Directory Assistance ("OS/DA") where BellSouth is providing Unbundled Local Switching or Resale, any of three technologies may be elected by AT&T; (1) Selective Carrier Routing using the BellSouth Advanced Intelligence Network ("AIN") platform; (2) Selective Carrier Routing using a Line Class Code ("LCC") platform; or (3) Via Originating Line Number Screening ("OLNS") Software. Custom Branding for Directory Assistance is not available for certain classes of service, such as: Hotel/Motel, WATS, cellular type 1, and certain PBX services. AT&T may also elect to have BellSouth provision Alternative Operator Services Routing ("AOSR") to AT&T using AIN or LCC technologies. Currently OLNS Software is only an option for unbranded and custom branding and is only available in Georgia. BellSouth will make Custom Branding and Unbranding via OLNS Software available to AT&T as it is rolled out in the remaining BellSouth region.
- 7.5.1 Selective Carrier Routing Using The Advance Intelligence Network ("AIN") Platform
- 7.5.1.1 BellSouth will provide AIN customized carrier routing at the request of AT&T as set forth in Section 6.4.
- 7.5.2 Selective Carrier Routing Using Line Class Codes
- 7.5.2.1 Selective Call Routing Using Lines Class Codes (SCR-LCC): LCCs and the trunking arrangements required to implement SCR-LCC shall be ordered through the BellSouth Account Team. BellSouth shall provide AT&T with all of the appropriate ordering forms and written methods and procedures required to identify to BellSouth the entirety of AT&T's request.

- 7.5.2.2 For each request for SCR-LCC, AT&T shall provide the following information, using the forms identified by BellSouth:
- 7.5.2.2.1 AT&T shall identify the BellSouth end offices where it would like to offer end user service;
- 7.5.2.2.2 NPA where such customized routing shall be employed, describe each set of end user call blocking restrictions;
- 7.5.2.2.3 AT&T shall indicate if the requested LCC will be used to serve the basic dialing arrangement (or calling area) or an optional dialing arrangement, whether the LCC will be used to support flat or measure rated services (e.g. BellSouth retail services may be flat or measure rated. If AT&T intends to Resale flat and measure rated BellSouth services and use selective routing to provide specific OS/DA services, it needs to request two LCCs to support both services. Unbundled Ports are measured services and the same LCC used to support measured Resale services may be used to supports selective call routing wit Unbundled Ports.), multi-line hunting and each class of service to be offered by AT&T;
- 7.5.2.2.4 AT&T shall provide a forecast of call volumes per NPA for each end office.
- 7.5.2.3 If a BellSouth end office serves multiple rate centers and AT&T intends to provide SCR-LCC for OS/DA branding to its end users in these multiple areas, unique LCCs must be established for each rate center. BellSouth shall verify the Line Class Code capacity for the end offices identified by AT&T. Within two weeks of receiving the request from AT&T, BellSouth shall notify AT&T in writing whether the Line Class Code and Selective Carrier Routing request can be satisfied.
- 7.5.2.4 BellSouth shall program the LCCs to meet AT&T's requested branding default or routing option in the end offices identified by AT&T. At the same time, BellSouth shall update all databases, including any look-up tables, necessary to accept and process AT&T-submitted LSRs to support its branding default or routing option as described in Section 7.5.3 of this Attachment.
- 7.5.2.5 The rates for Line Class Codes are set forth in Exhibit A of this Attachment. These charges include non-recurring charges to build and program each Line Class Codes in each end office.

7.5.2.6 AT&T-branded BellSouth OS/DA

7.5.2.6.1 Where BellSouth is providing Unbundled Local Switching or Resale to AT&T, and where BellSouth is providing AT&T-branded OS/DA through selective carrier routing using Line Class Code technology, AT&T's end user traffic is routed to a dedicated trunk group uniquely identified by LCC instructions.

7.5.2.6.2 If Line Class Code capacity exists within the end offices identified by the AT&T, and AT&T has requested AT&T-branded OS/DA, AT&T will order the required dedicated trunks from the desired BellSouth end office to the BellSouth TOPS Tandem. Separate trunk groups are required for Operator Services and for Directory Assistance. AT&T shall prepare and submit the appropriate forms to BellSouth, which shall review such documents and request any further information that may be necessary. AT&T shall verify and provide any information requested by BellSouth. After the determination made in 7.5.2.3 above, BellSouth will submit the appropriate documents to its internal organizations.

7.5.2.6.3 The intervals from the determination made in 7.5.2.3 above will be negotiated between the BellSouth Account Team and AT&T to establish the appropriate intervals based on the number of line class codes and end offices requested. The interval to provide dedicated trunking is approximately 45 calendar days for all trunks per end office where facilities are available. If LCCs have been requested for more than one end office in a single order, AT&T may request the order in which BellSouth shall implement the end offices. BellSouth may assign a Project Manager to ensure timely and accurate implementation.

7.5.2.7 Unbranded OS/DA

7.5.2.7.1 Where BellSouth is providing Unbundled Local Switching or Resale to AT&T, and where BellSouth is providing unbranded OS/DA through selective carrier routing using LCC technology, AT&T's end user traffic is routed to a trunk group(s) installed by BellSouth.

7.5.2.7.2 If LCC capacity exists within the end offices identified by AT&T, BellSouth shall order the trunk groups necessary to carry the unbranded Operator Services traffic to each TOPs tandem. The interval for the installation of the trunk groups and associated LCCs shall be approximately 45 calendar days from the determination made in 7.5.2.3 above, for each TOPS tandem. The number of trunk required shall be based upon the forecast of traffic volume received

from AT&T and may affect the provisioning interval. A separate trunk group is required for Operator Assistance and for Directory Assistance. AT&T shall prepare and submit the appropriate forms to BellSouth, which shall review such documents and request any further information that may be necessary. AT&T shall provide and verify any information requested by BellSouth. After the determination made in 7.5.2.3 above, BellSouth will submit the forms to its internal organizations.

7.5.2.7.3 The intervals from the determination made in 7.5.2.3 above shall be negotiated between the BellSouth Account Team and AT&T based on the number of line class codes and end offices requested. The interval for the installation of the trunks will be approximately 45 days for all trunks per end office where facilities are available. If LCCs have been requested for more than one end office in a single order, AT&T may request the order in which BellSouth shall implement the end offices. BellSouth may assign a Project Manager to ensure timely and accurate implementation.

7.5.2.8 Routing to an Alternative Operator Services Provider

7.5.2.8.1 Where BellSouth is providing the Unbundled Local Switching or Resale to AT&T, and where AT&T is utilizing an Alternative Operator Services Provider through selective carrier routing using LCC technology, AT&T's end user traffic will be routed to a dedicated trunk group, which shall be provisioned in accordance with BellSouth's and the Alternate Operator Service Provider's requirements, from the desired BellSouth End Offices to the Alternative Operator Services Point of Interface.

7.5.2.8.2 If Line Class Code capacity exists within the end offices identified by AT&T, and AT&T has requested an Alternate Operator Services Provider, AT&T end user traffic will be routed to a dedicated trunk group, which shall be provisioned in accordance with BellSouth's and the Alternative Operator Services Provider's requirements, from the desired BellSouth end offices to the Alternative Operator Services Provider Point of Interface. AT&T shall prepare and submit the appropriate forms to BellSouth, which shall review such documents and request any further information that may be necessary. AT&T shall verify and provide any information requested by BellSouth. After the determination made in 7.5.2.3 above, BellSouth will submit the appropriate forms to its internal organizations.

7.5.2.8.3 The intervals from the determination made in 7.5.2.3 shall be negotiated between the BellSouth Account Team and AT&T based on the number of line class codes and end offices requested. If LCCs

have been requested for more than one end office in a single order, AT&T may request the order in which BellSouth shall implement the end offices. BellSouth may assign a Project Manager to ensure timely and accurate implementation.

7.5.2.8.4 Where AT&T is using an Alternative Operator Services Provider, AT&T, may at its option, order dedicated trunks between its Alternative Operator Services Provider's Point of Interface and the BellSouth Operator Services Platform. If AT&T elects to install said dedicated trunks, AT&T's Operators may provide verify busy line or line interruption services on numbers located in the BellSouth Switch at the rates set forth in Exhibit A.

7.5.3 Procedures for Selective Carrier Routing Customer-Specific Electronic LSR Ordering

7.5.3.1 All AT&T OS/DA calls originated from a customer in an end office where BellSouth is providing the local switching to AT&T and where AT&T has requested only a single customized OS/DA routing option or branding default, shall be routed to that option by BellSouth following the submission of AT&T's LSR without the need for AT&T to provide any indication of the routing on the LSR. If AT&T has requested multiple customized OS/DA Routing options in an end office and the appropriate LCCs have been established, AT&T may order for an end user an OS/DA branding option other than the established default plan by providing an indicator identifying the specific routing to be used (Unbranded, Custom Branded, Self Branded). This indicator shall be a five character Selective Routing Code ("SRC") provided by BellSouth to AT&T and it shall be listed behind the ZSRC fid in the feature detail section of the LSR when ordering. The indicator used for each option may be the same for all end offices in a state (minimally) or for all offices in BellSouth's region (optionally).

7.6 Custom Branding AND Unbranding via Originating Line Number Screening (OLNS) Software

In addition to the branding methods described in this Section, Unbranding and Custom Branding are also available for Directory Assistance, Operator Call Processing or both via Originating Line Number Screening (OLNS) software. When utilizing this method of Unbranding or Custom Branding, AT&T shall not be required to purchase dedicated trunking.

- 7.6.1 For BellSouth to provide Unbranding or Custom Branding via OLNS software for Operator Call Processing or for Directory Assistance, BellSouth must load all CLECs' OCN(s) and telephone numbers associated with such OCN(s) in BellSouth's LIDB; provided, however, that if AT&T desires to offer Alternatively Billed Services (collect, third number billed and calling card calls) to its end users, AT&T must execute a BellSouth LIDB Storage Agreement. To implement Unbranding and Custom Branding via OLNS software, AT&T must submit a manual order form which requires, among other things, AT&T's Operating Company Number (OCN) and a forecast for the traffic volume anticipated for each BellSouth TOPS during the peak busy hour. AT&T shall provide updates to such forecast on a quarterly basis and at any time such forecasted traffic volumes are expected to change significantly. Upon AT&T's purchase of Unbranding or Custom Branding using OLNS software for any particular TOPS, all AT&T end users served by that TOPS will receive the Unbranded "no announcement" or the Custom Branded announcement. Orders for Unbranding or Custom Branding via OLNS software shall be completed in approximately 60 days.
- 7.6.2 Rates for Unbranding and Custom Branding via OLNS software for Directory Assistance and for Operator Call Processing are as set forth in this Attachment. Notwithstanding anything to the contrary in this Agreement, to the extent BellSouth is unable to bill AT&T applicable charges currently, BellSouth shall track such charges and will bill the same retroactively at such time as a billing process is implemented. In addition to the charges for Unbranding and Custom Branding via OLNS software, AT&T shall continue to pay BellSouth applicable labor and other charges for the use of BellSouth's Directory Assistance and Operator Call Processing platforms as set forth in this Attachment. Further, where AT&T is purchasing unbundled local switching from BellSouth, UNE usage charges for end office switching, tandem switching and transport, as applicable, shall continue to apply.
- 7.7 For Facilities Based Carriers
- 7.7.1 All Service Levels and branding by OLNS software require AT&T to order dedicated trunking from their end office(s) point of interface to the BellSouth TOPS Switches. Rates for trunks are set forth in applicable BellSouth tariffs.
- 7.7.2 Customized Branding includes charges for the recording of the branding announcement and the loading of the audio units in each TOPS Switch and Network Applications Vehicle (NAV) equipment for which AT&T requires service.

- 7.7.3 Directory Assistance customized branding uses:
 - 7.7.3.1 the recording of AT&T;
 - 7.7.3.2 the front-end loading of the Digital Recorded Announcement Machine (DRAM) in each TOPS switch.
- 7.7.4 Operator Call Processing customized branding uses:
 - 7.7.4.1 the recording of AT&T;
 - 7.7.4.2 the front-end loading of the DRAM in the TOPS Switch;
 - 7.7.4.3 the 0- automation loading for the audio units in the Enhanced Billing and Access Service (EBAS) in the Network Applications Vehicle (NAV).

8 Interoffice Transmission Facilities

- 8.1 BellSouth shall:
 - 8.1.1 Provide AT&T, upon request, exclusive use of interoffice transmission facilities dedicated to a particular end user or carrier, or use the features, functions, and capabilities of interoffice transmission facilities shared by more than one customer or carrier;
 - 8.1.2 Provide all technically feasible transmission facilities, features, functions, and capabilities that AT&T, upon request, could use to provide telecommunications services; and
 - 8.1.3 Permit, to the extent technically feasible, AT&T, upon request, to connect such interoffice facilities to equipment designated by AT&T, including but not limited to, AT&T's collocated facilities.

8.2 Shared Transport

- 8.2.1 Definition
 - 8.2.1.1 Shared Transport is defined as transmission facilities shared by more than one telecommunications carrier, including BellSouth, between end office switches, between end office switches and tandem switches, and between tandem switches in BellSouth's network.
- 8.2.2 Technical Requirements

- 8.2.2.1 Shared Transport provided on DS1 or VT1.5 circuits, shall, at a minimum, meet the performance, availability, jitter, and delay requirements specified for central office to central office connections in accordance with the applicable industry standard technical references.
- 8.2.2.2 Shared Transport provided on DS3 circuits, STS-1 circuits, and higher transmission bit rate circuits shall, at a minimum, meet the performance, availability, jitter, and delay requirements specified for central office to central office connections in accordance with the applicable industry standard technical references.
- 8.2.2.3 BellSouth shall be responsible for the engineering, provisioning, and maintenance of the underlying equipment and facilities that are used to provide Shared Transport.
- 8.2.2.4 At a minimum, Shared Transport shall meet all of the requirements set forth in the applicable industry standard technical references.
- 8.3 Dedicated Transport
- 8.3.1 Definition: Dedicated Transport is BellSouth transmission facilities, including all technically feasible capacity-related services including, but not limited to, DS1, DS3 and OCn levels, dedicated to a particular customer or carrier, that provides telecommunications between wire centers owned by BellSouth or requesting telecommunications carriers, or between switches owned by BellSouth or requesting telecommunications carriers.
- 8.3.2 BellSouth shall offer, at the rates set forth in Exhibit A, Dedicated Transport in each of the following manners:
 - 8.3.2.1 As capacity on a shared facility.
 - 8.3.2.2 As a circuit (e.g., DS1, DS3, OC-n, STS-1) dedicated to AT&T; and,
 - 8.3.2.3 As dedicated transport on an existing SONET ring. Such dedicated transport shall include all the features, functions, and capabilities of that existing SONET ring, to the extent technically feasible.
 - 8.3.2.4 Nothing in this Section shall be construed to require BellSouth to construct transport facilities where such a system does not presently exist, but BellSouth shall provide the electronics necessary to provide such dedicated transport to AT&T on existing facilities.

- 8.3.3 When Dedicated Transport is provided as a circuit or as capacity on a shared facility, it shall include, at Parity and on a nondiscriminatory basis, (as appropriate):
 - 8.3.3.1 Multiplexing functionality;
 - 8.3.3.2 Grooming functionality; and,
 - 8.3.3.3 Where available, redundant equipment and facilities necessary to support protection and restoration.

- 8.3.4 When Dedicated Transport is provided as a system, it shall include, at Parity and on a nondiscriminatory basis:
 - 8.3.4.1 Transmission equipment such as multiplexers, line terminating equipment, amplifiers, and regenerators;
 - 8.3.4.2 Inter-office transmission facilities such as optical fiber, Dark Fiber, copper twisted pair, and coaxial cable;
 - 8.3.4.3 Where available, redundant equipment and facilities necessary to support protection and restoration; and,
 - 8.3.4.4 Dedicated Transport includes the Digital Cross-Connect System (DCS) functionality as an option.

- 8.3.5 Technical Requirements - Dedicated Transport
 - 8.3.5.1 When BellSouth provides Dedicated Transport as a circuit or a system, the entire designated transmission circuit or system (e.g., DS1, DS3, STS-1) shall be dedicated to AT&T designated traffic.
 - 8.3.5.2 When requested by AT&T, Dedicated Transport shall provide physical diversity. Physical diversity means that two circuits are provisioned in such a way that, where available, no single failure of facilities or equipment will cause a failure on both circuits.
 - 8.3.5.3 When physical diversity is requested by AT&T, BellSouth shall provide the maximum feasible physical separation between transmission paths for all facilities and equipment (unless otherwise agreed by AT&T).
 - 8.3.5.4 Transmission rates shall be as specified by AT&T.

- 8.3.5.5 BellSouth shall offer the following interface transmission rates for Dedicated Transport:
 - 8.3.5.5.1 DS1 (Extended SuperFrame - ESF/B8ZS, D4, and unframed applications shall be provided);
 - 8.3.5.5.2 DS3 (C-bit Parity and unframed applications shall be provided);
 - 8.3.5.5.3 Where dedicated transport is provided over SONET, BellSouth shall provide it at Parity.
- 8.5.6 If requested by AT&T, BellSouth shall provide cross-office wiring up to a suitable Point of Termination (POT) between Dedicated Transport and AT&T's designated equipment. BellSouth shall provide the following equipment for the physical POT:
 - 8.3.5.6.1 DSX1 for DS1s or VT1.5s;
 - 8.3.5.6.2 DSX3 for DS3s or STS-1s; and
 - 8.3.5.6.3 LGX for optical signals (e.g., OC-3 and OC-12).
- 8.3.5.7 For Dedicated Transport provided by BellSouth, BellSouth shall design the system (including but not limited to facility routing and termination points) as specified by AT&T.
- 8.3.5.8 Where technically feasible and where available, BellSouth shall provide electronic provisioning control for dedicated transport.
- 8.3.5.9 Where technically feasible and where available, BellSouth shall provide electronic provisioning control for dedicated transport.
- 8.3.5.10 BellSouth shall offer Dedicated Transport together with and separately from DCS.
- 8.3.6 Technical Requirements - Dedicated Transport Using SONET Technology.
 - 8.3.6.1 BellSouth shall provide SONET standard interfaces in accordance with the applicable industry standards.
 - 8.3.6.2 At a minimum, Dedicated Transport shall meet each of the requirements set forth in the applicable technical references.
- 8.3.7 **Local Channel**

- 8.3.7.1 The Local Channel is the dedicated transmission path between AT&T's point of presence and the BSWC.
- 8.3.7.2 Local Channels may be used for either switched or non-switched traffic. Rates for Local Channels are contained in Exhibit A of this Attachment 2.
- 8.3.7.3 Technical Requirements.
 - 8.3.7.3.1 This Section sets forth technical requirements for all Dedicated Transport.
 - 8.3.7.3.2 When BellSouth provides Dedicated Transport as a circuit or a system, the entire designated transmission circuit or system (e.g., DS1, DS3, STS-1) shall be dedicated to AT&T designated traffic.
 - 8.3.7.3.3 BellSouth shall offer Dedicated Transport in all documented bandwidth interfaces used within BellSouth's network, including, but not limited to, DS1 and DS3 and OCn.
 - 8.3.7.3.4 For DS1 or VT1.5 circuits, Dedicated Transport shall, at a minimum, meet the performance, availability, jitter, and delay requirements specified for end user interface to central office connections in the technical reference set forth in the applicable industry standard technical reference.
 - 8.3.7.3.5 For DS3 circuits, STS-1 circuits, and higher rate circuits, Dedicated Transport shall, at a minimum, meet the performance, availability, jitter, and delay requirements specified for end user interface to central office connections in the technical reference set forth in the applicable industry standard technical reference.
 - 8.3.7.3.6 When requested by AT&T, Dedicated Transport shall provide physical diversity. Physical diversity means that two circuits are provisioned in such a way that no single failure of facilities or equipment will cause a failure on both circuits.
 - 8.3.7.3.7 When physical diversity is requested by AT&T, BellSouth shall provide the maximum feasible physical separation between intra-office and inter-office transmission paths (unless otherwise agreed by AT&T). BellSouth shall take appropriate steps to assure physical diversity continues to be provided for the duration of the period that AT&T employs or until such time that AT&T notifies BellSouth that physical diversity is no longer required.

- 8.3.7.3.8 Upon AT&T's request, BellSouth shall provide nondiscriminatory performance monitoring and alarming.
- 8.3.7.3.9 BellSouth shall offer the following interface transmission rates for Dedicated Transport:
 - 8.3.7.3.9.1 When Dedicated Transport is provided as a system, BellSouth shall design the system according to BellSouth's network infrastructure to allow for the termination points specified by AT&T.
 - 8.3.7.3.10 At a minimum, Dedicated Transport shall meet each of the requirements set forth in the applicable industry standard technical references.

8.4 DARK FIBER

8.4.1 Definition

- 8.4.1.1 Dark Fiber is optical transmission facilities without attached multiplexing, aggregation or other electronics that connects two points within BellSouth's network. Dark Fiber also includes strands of optical fiber existing in aerial or underground cable which may have lightwave repeater (regenerator or optical amplifier) equipment interspliced to it at appropriate distances, but which has no line terminating elements terminated to such strands to operationalize its transmission capabilities.

8.4.2 Requirements

- 8.4.2.1 BellSouth shall make available Dark Fiber where it exists in BellSouth's network and where, as a result of future building or deployment, it becomes available. If BellSouth has plans to use the fiber within a two-year planning period, there is no requirement to provide said fiber to AT&T.
- 8.4.2.2 If the requested dark fiber has any lightwave repeater equipment interspliced to it, BellSouth will remove such equipment at AT&T's request subject to time and materials charges.
- 8.4.2.3 AT&T may test the quality of the Dark Fiber to confirm its usability and performance specifications.
- 8.4.2.4 BellSouth shall use its best efforts to provide to AT&T information regarding the location, availability and performance of Dark Fiber within ten (10) business days for a records based answer and twenty (20) business days for a field based answer, after receiving a request

from AT&T ("Request"). Within such time period, BellSouth shall send written confirmation of availability of the Dark Fiber ("Confirmation"). From the time of the Request to forty-five (45) days after Confirmation, BellSouth shall hold such requested Dark Fiber for AT&T's use and may not allow any other party to use such media, including BellSouth.

- 8.4.2.5 BellSouth shall use its best efforts to make Dark Fiber available to AT&T within thirty (30) business days after it receives written confirmation from AT&T that the Dark Fiber previously deemed available by BellSouth is wanted for use by AT&T. This includes identification of appropriate connection points (e.g., Light Guide Interconnection ("LGX") or splice points) to enable AT&T to connect or splice AT&T provided transmission media (e.g., optical fiber) or equipment to the Dark Fiber.
- 8.4.2.6 Dark fiber shall meet the manufacturers' design specifications.
- 8.4.2.7 AT&T may splice and test Dark Fiber obtained from BellSouth using AT&T or AT&T designated personnel. BellSouth shall provide appropriate interfaces to allow splicing and testing of Dark Fiber. BellSouth shall provide an excess cable length of 25 feet minimum (for fiber in underground conduit) to allow the uncoiled fiber to reach from the manhole to a splicing van.

9 Signaling Networks and Call-Related Databases

- 9.1 BellSouth shall provide AT&T access to signaling networks, call-related databases, and service management systems on an unbundled basis for the provision of a telecommunications service.

9.2 Signaling Networks

- 9.2.1 Signaling networks include, but are not limited to, signaling links and signaling transfer points. When AT&T purchases unbundled switching capability from BellSouth, BellSouth shall provide access to its signaling network from that switch in the same manner in which it obtains access itself. BellSouth shall provide AT&T with its own switching facilities access to BellSouth's signaling network for each of the AT&T switches. This connection shall be made in the same manner as BellSouth connects one of its own switches to a signaling transfer point.
- 9.2.2 Signaling Link Transport is a set of two or four dedicated 56 Kbps. transmission paths between AT&T-designated Signaling Points of Interconnection ("SPOI") and BellSouth Point of Interconnection that provides appropriate physical diversity.

- 9.2.3 The network termination point where this interconnection takes place is called the STP port termination.
- 9.2.4 Technical Requirements
 - 9.2.4.1 Signaling Link Transport shall consist of full duplex mode 56 kbps transmission paths.
 - 9.2.4.2 Of the various options available, Signaling Link Transport shall perform in the following two ways:
 - 9.2.4.2.1 As an "A-link" which is a connection between a switch or SCP and a home Signaling Transfer Point Switch ("STPS") pair and consists of two links; and
 - 9.2.4.2.2 As a "D/B-link" which is a connection between two STPS pairs in different company networks (e.g., between two STPS pairs for two Competitive Local Exchange Carriers ("CLECs")) and consists of four links.
 - 9.2.4.3 A signaling link layer shall satisfy a performance objective such that:
 - 9.2.4.3.1 There shall be no more than two minutes down time per year for an A-link layer; and
 - 9.2.4.3.2 There shall be negligible (less than 2 seconds) down time per year for a B-link layer.
 - 9.2.4.4 A signaling link layer shall satisfy interoffice and intraoffice diversity of facilities and equipment, such that:
 - 9.2.4.4.1 No single failure of facilities or equipment causes the failure of both links in an A-link layer (i.e., the links should be provided on a minimum of two separate physical paths end-to-end); and
 - 9.2.4.4.2 No two concurrent failures of facilities or equipment shall cause the failure of all four links in a D/B-link layer (i.e., the links should be provided on a minimum of three separate physical paths end-to-end).
 - 9.2.4.5 The Signaling Point of Interconnection (SPOI) for each link shall be located at a cross-connect element, such as a DSX-1, in the central office where BellSouth STPS is located. There shall be a DS1 or higher rate transport interface at each of the SPOIs. Each signaling link shall appear as a DS0 channel within the DS1 or higher rate interface. BellSouth shall offer higher rate DS1 signaling for interconnecting AT&T local switching systems or STPSs with BellSouth STPSs as soon as these become approved ANSI standards and

available capabilities of BellSouth STPSs. BellSouth and AT&T will work jointly to establish mutually acceptable SPOs.

9.2.5 Signaling Transfer Points

9.2.5.1 Definition

9.2.5.1.1 Signaling Transfer Points is a signaling network function that includes all of the capabilities provided by the STPSs and their associated signaling links which enable the exchange of SS7 messages among and between switching elements, database elements and STPS.

9.2.5.2 Technical Requirements

9.2.5.2.1 STPs shall provide access to Network Elements connected to BellSouth SS7 network. These include:

9.2.5.2.1.1 BellSouth Service Control Points/DataBases and

9.2.5.2.1.2 Third-party-provided STPSs.

9.2.5.2.2 The connectivity provided by STPs shall fully support the functions of all Network Elements and AT&T or other third-party switching systems and STPs connected to BellSouth's SS7 network. This explicitly includes the use of BellSouth's SS7 network to convey messages which neither originate nor terminate at a signaling end point directly connected to BellSouth's SS7 network (i.e., transient messages). When BellSouth SS7 network is used to convey transient messages, there shall be no alteration of the Integrated Services Digital Network User Part ("ISDNUP") or Transaction Capabilities Application Part ("TCAP") user data that constitutes the content of the message.

9.2.5.2.3 If a BellSouth tandem switch routes calling traffic, based on dialed or translated digits, on SS7 trunks between an AT&T local switch and third party local switch, BellSouth SS7 network shall convey the TCAP messages that are necessary to provide Call Management features (Automatic Callback, Automatic Recall, and Screening List Editing) between the AT&T local STPSs and the STPSs that provide connectivity with the third party local switch, even if the third party local switch is not directly connected to BellSouth STPSs.

9.2.5.2.4 STPs shall provide all functions of the MTP as defined in the applicable industry standard technical references.

9.2.5.2.5 STPs shall provide on a non-discriminatory basis all functions of the Operations, Maintenance and Administration Part ("OMAP") commonly

provided by STPSs. All OMAP functions will be on a "where available" basis and can include:

- 9.2.5.2.5.1 MTP Routing Verification Test ("MRVT") and
- 9.2.5.2.5.2 SCCP Routing Verification Test ("SRVT").
- 9.2.5.2.6 In cases where the destination signaling point is a BellSouth local or tandem switching system or database, or is an AT&T or third party local or tandem switching system directly connected to the BellSouth SS7 network, STPs shall perform MRVT and SRVT to the destination signaling point. In all other cases, STPs shall perform MRVT and SRVT to a gateway pair of STPSs in an SS7 network connected with the BellSouth SS7 network. This requirement shall be superseded by the specifications for Internetwork MRVT and SRVT if and when these become approved ANSI standards and available capabilities of BellSouth STPSs, and if mutually agreed upon by AT&T and BellSouth.
- 9.2.5.2.7 BellSouth STPs shall route mutually agreeable AIN responses from the AT&T SCP via SS7 network interconnect to the local switch designated in the Signaling Connection Control Part ("SCCP") called party address.
- 9.2.5.2.8 STPs shall be equal to or better than the technical specifications set forth in the applicable industry standard technical references.

9.2.5.3 Message Screening

- 9.2.5.3.1 BellSouth shall set message screening parameters so as to accept messages from AT&T local or tandem switching systems destined to any signaling point in the BellSouth SS7 network or any network interconnected to the BellSouth SS7 network with which the AT&T switching system has a legitimate signaling relationship.
- 9.2.5.3.2 BellSouth shall set message screening parameters so as to accept messages destined to/from an AT&T local or tandem switching system or to/from an AT&T Service Control Point from any signaling point or network interconnected to the BellSouth SS7 network with which the AT&T switching system has a legitimate signaling relationship.

9.3 SS7 Advanced Intelligent Network ("AIN") Access

- 9.3.1 SS7 AIN Access shall provide the AT&T SCP access to BellSouth local switch via interconnection of BellSouth SS7 and AT&T SS7 Networks. BellSouth shall offer SS7 access through its STPs. If BellSouth

requires a mediation device on any part of its network, BellSouth must route its calls in the same manner. The interconnection arrangement shall result in the BellSouth local switch recognizing the AT&T SCP as at least at parity with BellSouth's SCP's in terms of interfaces, performance and capabilities.

- 9.3.2 SS7 AIN Access is the provisioning of AIN triggers in a BellSouth local switch and interconnection of the BellSouth SS7 network with the AT&T SS7 network to exchange TCAP queries and responses with an AT&T SCP.

9.4 Call-Related DataBases

9.4.1 Definition

- 9.4.1.1 Call-related databases are defined as databases, other than operations support systems, that are used in signaling networks for billing and collection, or the transmission, routing, or other provision of a telecommunications service. For purposes of switch query and database response through a signaling network, BellSouth shall provide access to its call-related databases, including but not limited to, the Calling Name Database, 911 Database, E911 Database, Line Information Database, Toll Free Calling Database, Advanced Intelligent Network Databases, and downstream number portability databases by means of physical access at the signaling transfer point linked to the unbundled databases. BellSouth shall not be required to unbundle the services created in the AIN platform and architecture that qualify for proprietary treatment. BellSouth shall allow AT&T when AT&T has purchased BellSouth's local switching capability to use BellSouth's service control point element in the same manner, and via the same signaling links, as BellSouth itself. BellSouth shall allow AT&T when it has deployed its own switch, and has linked that switch to BellSouth's signaling system, to gain access to BellSouth's service control point in a manner that allows AT&T to provide any call-related database-supported services to customers served by AT&T's switch. BellSouth shall provide AT&T, upon request, with access to call-related databases in a manner that complies with section 222 of the Act.

- 9.4.2 A Service Control Point ("SCP") is a specific type of Database functionality deployed in a Signaling System 7 ("SS7") network that executes service application logic in response to SS7 queries sent to it by a switching system also connected to the SS7 network.

9.4.3 Technical Requirements

9.4.3.1 Requirements for call-related databases within this section address storage of information, access to information (e.g., signaling protocols, response times), and administration of information (e.g., provisioning, administration, and maintenance). All call-related databases shall be provided in accordance with the following requirements:

9.4.3.1.1 BellSouth shall provide physical access to SCPs through the SS7 network and protocols, as specified in this Attachment 2, with TCAP as the application layer protocol.

9.4.3.1.2 BellSouth shall provide physical interconnection to databases via industry standard interfaces and protocols.

9.4.3.2 The reliability of interconnection options shall be consistent with requirements for diversity and survivability.

9.4.4 Database Availability

9.4.4.1 Call-related databases shall have a maximum unscheduled unavailability of 30 minutes per year. Unavailability due to software and hardware upgrades shall be scheduled during minimal usage periods and only be undertaken upon proper notification to providers which might be impacted. Any downtime associated with the provision of call-related databases will impact all service providers, including BellSouth, equally.

9.4.4.2 Any AT&T order for data to be added, modified or deleted from the databases shall be consistent with the ordering and provisioning requirements of this Agreement.

9.4.4.3 BellSouth shall make available call-related database functionality and complete database transactions (e.g., add, modify or delete) for AT&T customer records stored in BellSouth's databases on a basis that is equivalent to that which it provides to itself or third-party requesting telecommunications carriers.

9.4.5 Line Information Database ("LIDB")

9.4.5.1 AT&T acknowledges that BellSouth will store in its LIDB only records relating to service in the BellSouth region.

9.4.5.2 Definition.

9.4.5.2.1 The LIDB is a transaction-oriented database accessible through Common Channel Signaling ("CCS") networks. It contains records associated with customer Line Numbers and Special Billing Numbers relating to service in the BellSouth region.

9.4.5.2.2 The LIDB Storage Agreement, which contains the terms and conditions for AT&T's access to LIDB, is attached as Exhibit A to Attachment 6, incorporated herein by this reference.

9.4.6 Toll Free Number Database

9.4.6.1 The Toll Free Number Database is a SCP that provides functionality necessary for toll free (e.g., 800 and 888) number services by providing routing information and additional so-called vertical features during call set-up in response to queries from SSPs. BellSouth shall provide the Toll Free Number Database in accordance with the following:

9.4.6.1.1 BellSouth shall make BellSouth Toll Free Number Database available for AT&T to query with a toll-free number and originating information.

9.4.6.1.2 The Toll Free Number Database shall return carrier identification and, where applicable, the queried toll free number, translated numbers and instructions as it would in response to a query from a BellSouth switch.

9.4.6.2 Interface Requirements

9.4.6.2.1 The signaling interface between the AT&T or other local switch and the Toll-Free Number database shall use the TCAP protocol and in the signaling network interface as specified in the applicable industry standard technical references.

9.4.7 Automatic Location Identification/Data Management System ("ALI/DMS")

9.4.7.1 The ALI/DMS Database contains end user information (including name, address, telephone information, and sometimes special information from the local service provider or customer) used to determine to which PSAP to route the call. The ALI/DMS database is used to provide more routing flexibility for E911 calls than 911. BellSouth shall provide the Emergency Services Database in accordance with the following:

9.4.7.2 Technical Requirements

9.4.7.2.1 BellSouth shall provide an electronic interface to the ALI/DMS database, through which AT&T or its agent may provide a daily update of AT&T Customer Information. BellSouth shall provide AT&T with record input format, consistent with the requirements imposed on BellSouth by the governmental body administering 911 services. BellSouth shall provide error reports from the ALI/DMS data base to

AT&T as soon as possible, but in any event, within 24 hours after AT&T or its agents enters information into the ALI/DMS data base. The error reports may be provided electronically if AT&T purchases the capability. If an electronic interface is not available as an offering or because of a system outage for AT&T or its agents to provide daily updates to the ALI/DMS database or for BellSouth to provide error reports from the ALI/DMS database, BellSouth shall establish a process or procedure to receive, send and process within one business day AT&T Customer Information. The error files will contain the AT&T reference date and file number of the original record sent.

- 9.4.7.2.2 The ALI/DMS database shall contain the following end user information:
 - 9.4.7.2.2.1 Name;
 - 9.4.7.2.2.2 Address;
 - 9.4.7.2.2.3 Telephone number; and
 - 9.4.7.2.2.4 Other information as appropriate (e.g., whether an end user is blind or deaf or has another disability).
- 9.4.7.2.3 When the BellSouth is responsible for administering the ALI/DMS database in its entirety, ported number NXXs entries for the ported numbers should be maintained unless AT&T requests otherwise and shall be updated if AT&T requests, provided AT&T supplies BellSouth with the updates.
- 9.4.7.2.4 When Remote Call Forwarding ("RCF") is used to provide number portability to the local end user and a remark or other appropriate field information is available in the database, the shadow or "forwarded-to" number and an indication that the number is ported shall be added to the end user record.
- 9.4.7.2.5 If BellSouth is responsible for configuring PSAP features (for cases when the PSAP or BellSouth supports an ISDN interface) it shall ensure that CLASS Automatic Recall (Call Return) is not used to call back to the ported number. Although BellSouth currently does not have ISDN interface, BellSouth agrees to comply with this requirement once ISDN interfaces are in place.
- 9.4.7.2.6 At either Party's option, however not to exceed annually unless otherwise agreed to by the Parties, the databases of both Parties shall be compared for accuracy and uniformity. If any discrepancies are found as a result of the comparison, the Parties shall work

cooperatively to correct the discrepancies within a reasonable time. The cost of the implementation of the request made other than annually shall be borne by the Party making the request.

9.4.7.3 Interface Requirements

9.4.7.3.1 The interface between the E911 Switch or Tandem and the ALI/DMS database for AT&T customers shall meet industry standards.

9.4.8 Calling Name Delivery Database Service

9.4.8.1 Calling Name Delivery Database Service (“CNAM”) provides AT&T the ability to associate a name with the calling party number, allowing the end user subscriber (to which a call is being terminated) to view the calling party’s name before the call is answered. This service also provides AT&T the opportunity to load and store its subscriber name in the BellSouth CNAM SCPs.

9.4.8.2 The CNAM Database Service Agreement is included as **Exhibit B** to this Attachment 2 and incorporated herein by this reference.

10 Directory Assistance Database Service (“DADS”)

10.1 Directory Assistance (“DA”) database contains all customer data in the database used by BellSouth to provide its own DA service and where BellSouth is authorized to include the customer data of a telecommunications carrier in the database available to AT&T. BellSouth shall provide access to the DA database in one of two manners.

10.2 BellSouth shall make its Directory Assistance Database Service (“DADS”) available solely for the expressed purpose of providing Directory Assistance type services to AT&T end users. Directory Assistance type service is defined as a service that allows AT&T end users to obtain the name, telephone numbers and addresses of other subscribers of telecommunications services. AT&T agrees that Directory Assistance Database Service (“DADS”) will not be used for any purpose which violates federal or state laws, statutes, regulatory orders or tariffs. Except for the permitted use, AT&T shall not disclose DADS and shall provide due care in providing for the security and confidentiality of DADS. Further, AT&T authorizes the inclusion of AT&T’s Directory Assistance listings in the BellSouth Directory Assistance products.

10.3 BellSouth shall provide AT&T initially with a base file of subscriber listings which reflect all listing change activity occurring since AT&T’s

most recent update via magnetic tape, and subsequently using electronic connectivity such as Network Data Mover to be developed mutually by AT&T and BellSouth. AT&T agrees to assume the costs associated with CONNECT: Direct™ connectivity, which will vary depending upon volume and mileage.

- 10.4 BellSouth will require approximately one month after receiving an order to prepare the base file. BellSouth will provide daily updates to AT&T which will reflect listing change activity occurring since AT&T's most recent update. BellSouth shall provide updates to AT&T on a business, residence, or combined business and residence basis. AT&T agrees that the updates shall be used solely to keep the information current. Delivery of daily updates will commence the day after AT&T receives the base file.
- 10.5 BellSouth is authorized to include AT&T Directory Assistance listing information in its Directory Assistance Database Service. Any other use by BellSouth of AT&T Directory Assistance listing information is not authorized and with the exception of a request for DADS, BellSouth shall refer any request for such information to AT&T.
- 10.6 BellSouth shall provide to AT&T, upon request, via DADs, the names and addresses for BellSouth.
- 10.7 AT&T and other telecommunication carriers' subscribers that have unlisted and non-published directory listings. The data files shall contain a special indicator showing that the subscribers account is unlisted or unpublished.
- 10.8 Rates for DADS are as set forth in Exhibit A of this Attachment 2.
- 10.9 Direct Access to Directory Assistance Service ("DADAS") will provide AT&T's directory assistance operators with the ability to search all available BellSouth subscriber listings using the Directory Assistance search format. Subscription to DADAS will allow AT&T to utilize its own switch, operator workstations and optional audio subsystems.
- 10.10 BellSouth will provide DADAS from its DA location. AT&T will access the DADAS system via BellSouth provided point of availability. AT&T has the responsibility of providing the physical links required to connect to the point of availability. These facilities may be purchased from BellSouth as rates and charges billed separately from the charges associated with this offering.

- 10.11 A specified interface to each AT&T subsystem will be provided by BellSouth. Interconnection between AT&T's system and a specified BellSouth location will be pursuant to the use of AT&T-owned or AT&T-leased facilities and shall be appropriate sized based upon the volume of queries being generated by AT&T.
- 10.12 The specifications for the three interfaces necessary for interconnection are available in the following documents:
 - 10.12.1 DADAS to Subscriber Operator Position System – Northern Telecom Document CSI-2300-07; Universal Gateway/Position Message Interface Format Specification;
 - 10.12.2 DADAS to Subscriber Switch – Northern Telecom Document Q210-1 Version A107; NTDMS/CCIDAS System Application Protocol; and AT&T Document 250-900-535 Operator Services Position System Listing Service and Application Call Processing Data Link Interface Specification;
 - 10.12.3 DADAS to Audio Subsystem (Optional) – Directory One Call Control to Audio Response Unit system interface specifications are available through Northern Telecom as a licensed access protocol – Northern Telecom Document 355-004424 and Gateway/Interactive Voice subsystem Protocol Specification.
 - 10.12.4 Rates for DADAS are as set forth in Exhibit A of this Attachment 2.

11 Service Management System

11.1 Definition

- 11.1.1 A Service Management System is defined as a computer database or system not part of the public switched network that, among other things: (1) interconnects to the service control point and sends to that service control point the information and call processing instructions needed for a network switch to process and complete a telephone call; and (2) provides telecommunications carriers with the capability of entering and storing data regarding the processing and completing of a telephone call. BellSouth shall provide AT&T, upon request, with access to a Service Management System in a manner that complies with Section 222 of the Act.

- 11.2 BellSouth shall provide AT&T with the information necessary to enter correctly, or format for entry, the information relevant for input into BellSouth's service management system.
- 11.3 BellSouth shall provide AT&T the same access to design, create, test, and deploy Advanced Intelligent Network-based services at the service management system, through a service creation environment, that BellSouth provides itself.
- 11.4 BellSouth shall provide access to any and all BellSouth non-proprietary service applications resident in BellSouth's SCP. Such access may be from AT&T's switch or BellSouth's unbundled Local Switching element.
- 11.5 Service Management Systems provide operational interfaces to allow for provisioning, administration and maintenance of subscriber data and service application data stored in SCPs.
- 11.6 BellSouth's Service Creation Environment ("SCE") and Service Management System ("SMS") Advanced Intelligent Network ("AIN") Access shall provide AT&T the capability that will allow AT&T to create service applications in a BellSouth Service Creation Environment and deploy those applications in a BellSouth SMS to a BellSouth SCP. AT&T's service applications interact with AIN triggers provisioned on a BellSouth SSP. BellSouth shall provide AT&T access to the BellSouth Service Creation Environment in a manner equal to what BellSouth provides itself or requesting telecommunications carriers.
- 11.7 BellSouth's SCE/SMS AIN Access shall provide access to SCE hardware, software, testing and technical support (e.g., help desk, system administrator) resources available to AT&T. Scheduling procedures shall provide AT&T equivalent priority to these resources.
- 11.8 BellSouth SCP shall partition and protect AT&T service logic and data from unauthorized access, execution or other types of compromise.
- 11.9 When AT&T selects SCE/SMS AIN Access, BellSouth shall provide training, documentation, and technical support to enable AT&T to use BellSouth's SCE/SMS AIN Access to create and administer applications. Training, documentation, and technical support will address use of SCE and SMS access and administrative functions, but will not include support for the creation of a specific service application.
- 11.10 When AT&T selects SCE/SMS AIN Access, BellSouth shall provide for a secure, controlled access environment in association with its internal use of AIN components.

11.11 When AT&T selects SCE/SMS AIN Access for providing services on AT&T's network, BellSouth and AT&T will work cooperatively to resolve technical and provisioning issues.

12 Trunk Interface Requirements

12.1 If a municipality has converted to E911 service, AT&T will forward 911 calls to the appropriate E911 primary tandem, along with ANI, based upon the current E911 end office to tandem homing arrangement as provided by BellSouth. If the primary tandem trunks are not available, AT&T will alternatively route the call to a designated 7-digit local number residing in the appropriate PSAP. This call will be transported over BellSouth's interoffice network and will not carry the ANI of the calling party, which is in parity with BellSouth's handling of 911 calls from its customers.

12.2 911/E911 Trunks

12.2.1 Local Switch and Access Tandem Trunks

12.2.1.1 BellSouth shall provide trunks groups provisioned exclusively to carry intraLATA traffic, as designated by AT&T.

12.2.1.2 BellSouth shall provide trunk groups provisioned exclusively to carry interLATA traffic, as designated by AT&T.

12.2.1.3 BellSouth shall provide SS7 trunks which provide SS7 interconnection. At AT&T's request, MF trunks may be substituted for SS7 trunks where applicable.

12.2.1.4 BellSouth shall simultaneous route calls based on dialed digits (in accordance with the standard GR-317-CORE), and Carrier Identification Code (in accordance with the standard GR-394-CORE) over a single SS7 trunk group.

12.3 911 and E911

12.3.1 If AT&T orders Services and Elements, then AT&T is also responsible for providing E911 to its end users. BellSouth agrees to offer access to the 911/E911 network pursuant to the following terms and conditions set forth in this Attachment.

12.3.2 Definition

12.3.2.1 The 911 and E911 are requirements that provide a caller access to the applicable emergency service bureau by dialing a 3-digit universal

telephone number (911). 911 Arrangements are arrangements for routing 911 calls from AT&T end users to the appropriate PSAP, passing certain end user information for display at the PSAP answering station based on the class of 911 service (911 or E911) deployed in the area. BellSouth shall provide 911 Arrangements to AT&T in accordance with the provisions below in areas where AT&T is authorized to provide local exchange service and BellSouth is the 911 service provider. The provisions in this Section apply only to 911 Arrangements. The 911 functionality for Local Services Resale shall be governed by provisions in Attachment 1 of this Agreement incorporated herein by reference. In providing 911 Arrangements to AT&T, BellSouth shall comply with all laws, rules and regulations concerning emergency services. The 911 and E911 functions provided to AT&T shall be at least equal in quality and functionality with the support and services that BellSouth provides to its own retail end users.

12.3.3 Requirements

12.3.3.1 911 Service Provisioning. For 911 service, BellSouth will provide to AT&T a list consisting of each municipality that subscribes to 911 service. The list will also provide, if known, the E911 conversion date for each municipality and, for network routing purposes, a ten-digit directory number representing the appropriate emergency answering position for each municipality subscribing to 911. AT&T will be required to arrange to accept 911 calls from its end users in municipalities that subscribe to 911 service and translate the 911 call to the appropriate 10-digit directory number as stated on the list provided by BellSouth. AT&T will be required to route that call to BellSouth at the appropriate to install dedicated facilities from its serving wire center to the appropriate BellSouth tandem or end office. When a municipality converts to E911 service, AT&T will be required to discontinue the 911 procedures and being using E911 procedures.

12.3.3.2 E911 Service Provisioning. For E911 service, AT&T will be required to install a minimum of two dedicated trunks originating from the AT&T serving wire center and terminating to the appropriate E911 tandem. The dedicated trunks shall be, at a minimum, DS-0 level trunks configured either as a 2-wire analog interface or as part of a digital (1.544 Mb/s) interface. Either configuration shall use CAMA-type signaling with multifrequency ("MF") pulsing that will deliver automatic number identification ("ANI") with the voice portion of the call. If the user interface is digital, MF pulses, as well as other AC signals, shall be encoded per the u-255 Law convention. AT&T will be required to provide BellSouth daily updates to the E911 database. AT&T will be required to forward 911 calls to the appropriate E911 tandem, along

with ANI, based upon the current E911 end office to tandem homing arrangement as provided by BellSouth. If the E911 tandem trunks are not available, AT&T will be required to route the call to a designated 10-digit local number residing in the appropriate PSAP. This call will be transported over BellSouth's interoffice network and will not carry the ANI of the calling party. AT&T shall be responsible for providing BellSouth with complete and accurate data for submission to the 911/E911 database for the purpose of providing 911/E911 to its end users.

12.3.4 Technical Requirements

12.3.4.1 At AT&T's request, BellSouth and AT&T shall establish dedicated trunk groups to route E911 calls placed by AT&T end users to the appropriate BellSouth 911 tandem or selective router. Trunks shall be established as CAMA MF trunks until SS7 connectivity is available. Thereafter, trunks shall be established with SS7 signaling.

12.3.4.2 BellSouth shall provision 911 trunks within 30 calendar days of receipt of AT&T's order, or such shorter time as may be established by law, rule, regulation or Commission or F.C.C. order. Alternatively, at its option, AT&T may provide the trunks. Regardless of which party provides the trunks, prior to placing a trunk in service BellSouth and AT&T shall cooperate in testing to assure proper functioning of the E911 system for calls delivered over the trunk.

12.3.4.3 BellSouth shall assure sufficient capacity at the 911 tandem or selective router to meet AT&T's requests for interconnection within 30 calendar days after receipt of the request. There shall be no limit on the number of trunks used by AT&T to connect to the 911 tandem or selective router. Interconnection to the 911 tandem shall be established to provide path and route diversity.

12.3.4.4 BellSouth shall provide the following information to AT&T, and shall promptly notify AT&T of any changes:

12.3.4.4.1 BellSouth processes and requirements for ordering trunks for 911 trunks and interconnection to the 911 tandem or selective router.

12.3.4.4.2 Trunk group specifications.

12.3.4.4.3 E911 tandem CLLI codes, circuit IDs, point codes, LEC order number, and IS code and address.

12.3.4.4.4 Description of BellSouth's diversity for facility routing.

- 12.3.4.4.5 Maintenance procedures for 911 trunk groups, including, but not limited to, contact names and numbers, escalation lists, and the hours that maintenance is available.
- 12.3.5 E911 Call Routing and Provision Customer Information to PSAP
 - 12.3.5.1 BellSouth shall route E911 calls delivered by AT&T to BellSouth's 911 tandems or selective routers to PSAPs in the same manner that BellSouth routes E911 calls from its own retail customers. BellSouth shall provide and validate AT&T customer information from the ALI/ANI database in the same manner BellSouth provides and validates information for its own retail customers.
 - 12.3.5.2 BellSouth shall automatically update the ALI/DMS databases with respect to NPA split conversions.
- 12.3.6 Master Street Address Guide ("MSAG")
 - 12.3.6.1 BellSouth shall provide AT&T access to the MSAG at least equal in quality and functionality with the access BellSouth provides to itself. BellSouth shall provide AT&T with a complete copy of the MSAG via CD Rom which is usable with personal computers, free of charge, once each year. Quarterly updates for each state are available for an additional charge. BellSouth shall cooperate with AT&T to ensure the accuracy of information about AT&T Customers in the MSAG and shall assist in resolving any errors. If BellSouth discovers an error in the MSAG, BellSouth shall notify PSAPs and AT&T of any errors in the MSAG concerning AT&T Customers.
- 12.3.7 Other
 - 12.3.7.1 BellSouth shall provide AT&T with 10-digit emergency telephone numbers for operator handling of emergency calls, at least equal in quality and functionality with the provisions of such information to itself.
- 12.3.8 Technical References
 - 12.3.8.1 BellSouth shall provide 911 Arrangements to AT&T based upon modified NENA 2 Recommendations.
- 12.3.9 Rates. Charges for 911/E911 service are borne by the municipality purchasing the service. BellSouth will impose no charge on AT&T beyond applicable charges for BellSouth trunking arrangements.
- 12.3.10 The 911 and E911 functions provided to AT&T shall be at least at parity with the support and services that BellSouth provides to its end users for such similar functionality.

- 12.3.11 Detailed Practices and Procedures. The detailed practices and procedures contained in the E911 Local Exchange Carrier Guide For Facility-Based Providers as amended from time to time during the term of this Agreement will determine the appropriate practices and procedures for BellSouth and AT&T to follow in providing 911/E911 services.

BELLSOUTH / ATT RATES
Unbundled Network Elements
KENTUCKY

CATEGORY	NOTES	UNBUNDLED NETWORK ELEMENT	Intrm	Zone	BOS	USOC	RATES						OSS RATES							
							Rec	First	Advt	Disconn	Advt	SOMEC	SOMAN	SOMAN	SOMAN	SOMAN	SOMAN	SOMAN		
							Nonrecurring				Nonrecurring			Site Order Submitted Manually per LSR	Site Order Manually per LSR	Incremental Charge - Manual Change - Manual Change - 1st Electronic-1st	Incremental Charge - Manual Change - Manual Change - 1st Electronic-Add1	Incremental Charge - Manual Change - Manual Change - 1st Electronic-Disc 1st	Incremental Charge - Manual Change - Manual Change - 1st Electronic-Add1	
		2 Wire Unbundled ADSL Loop without manual service inquiry & facility reservation - Zone 2		2	U/L	U/LA.2W	\$16.46	\$206.25	\$129.42	\$100.89	\$15.88	\$10.89	\$22.00							
		2 Wire Unbundled ADSL Loop without manual service inquiry & facility reservation - Zone 3		3	U/L	U/LA.2W	\$28.40	\$206.25	\$129.42	\$100.89	\$15.88	\$10.89	\$22.00							
		Order Coordination for Specified Conversion Time (per LSR)			U/L	O/COSL	\$36.18													
		2-WIRE HIGH BIT RATE DIGITAL SUBSCRIBER LINE (HDSL) COMPATIBLE LOOP																		
		2-WIRE HIGH BIT RATE DIGITAL SUBSCRIBER LINE (HDSL) COMPATIBLE LOOP																		
		2 Wire Unbundled HDSL Loop including manual service inquiry & facility reservation - Zone 1		1	U/H	U/HL.2X	\$6.29	\$713.50	\$609.44			\$10.89	\$22.00							
		2 Wire Unbundled HDSL Loop including manual service inquiry & facility reservation - Zone 2		2	U/H	U/HL.2X	\$11.78	\$713.50	\$609.44			\$10.89	\$22.00							
		2 Wire Unbundled HDSL Loop including manual service inquiry & facility reservation - Zone 3		3	U/H	U/HL.2X	\$20.33	\$713.50	\$609.44			\$10.89	\$22.00							
		Order Coordination for Specified Conversion Time			U/H	O/COSL	\$36.18													
		2 Wire Unbundled HDSL Loop without manual service inquiry and facility reservation - Zone 1		1	U/H	U/HL.2W	\$6.29	\$222.58	\$146.75	\$100.89	\$15.88	\$10.89	\$22.00							
		2 Wire Unbundled HDSL Loop without manual service inquiry and facility reservation - Zone 2		2	U/H	U/HL.2W	\$11.78	\$222.58	\$146.75	\$100.89	\$15.88	\$10.89	\$22.00							
		2 Wire Unbundled HDSL Loop without manual service inquiry and facility reservation - Zone 3		3	U/H	U/HL.2W	\$20.33	\$222.58	\$146.75	\$100.89	\$15.88	\$10.89	\$22.00							
		Order Coordination for Specified Conversion Time			U/H	O/COSL	\$36.18													
		4-WIRE HIGH BIT RATE DIGITAL SUBSCRIBER LINE (HDSL) COMPATIBLE LOOP																		
		4 Wire Unbundled HDSL Loop including manual service inquiry and facility reservation - Zone 1		1	U/H	U/HL.4X	\$7.88	\$748.93	\$646.17			\$10.89	\$22.00							
		4 Wire Unbundled HDSL Loop including manual service inquiry and facility reservation - Zone 2		2	U/H	U/HL.4X	\$14.38	\$748.93	\$646.17			\$10.89	\$22.00							
		4 Wire Unbundled HDSL Loop including manual service inquiry and facility reservation - Zone 3		3	U/H	U/HL.4X	\$24.82	\$748.93	\$646.17			\$10.89	\$22.00							
		Order Coordination for Specified Conversion Time			U/H	O/COSL	\$36.18													
		4 Wire Unbundled HDSL Loop without manual service inquiry and facility reservation - Zone 1		1	U/H	U/HL.4W	\$7.88	\$279.79	\$203.96	\$109.64	\$20.64	\$10.89	\$22.00							
		4 Wire Unbundled HDSL Loop without manual service inquiry and facility reservation - Zone 2		2	U/H	U/HL.4W	\$14.38	\$279.79	\$203.96	\$109.64	\$20.64	\$10.89	\$22.00							
		4 Wire Unbundled HDSL Loop without manual service inquiry and facility reservation - Zone 3		3	U/H	U/HL.4W	\$24.82	\$279.79	\$203.96	\$109.64	\$20.64	\$10.89	\$22.00							
		Order Coordination for Specified Conversion Time			U/H	O/COSL	\$36.18													
		4-WIRE DS1 DIGITAL LOOP																		
		4-Wire DS1 Digital Loop - Zone 1		1	U/S	U/SL.XX	\$50.26	\$849.80	\$523.27			\$10.89	\$22.00							
		4-Wire DS1 Digital Loop - Zone 2		2	U/S	U/SL.XX	\$94.06	\$849.80	\$523.27			\$10.89	\$22.00							
		4-Wire DS1 Digital Loop - Zone 3		3	U/S	U/SL.XX	\$162.34	\$849.80	\$523.27			\$10.89	\$22.00							
		Order Coordination for Specified Conversion Time			U/S	O/COSL	\$36.18													
		4 WIRE 19.2, 56 OR 64 Kbps DIGITAL GRADE-LEVEL LOOP																		
		4 Wire Unbundled Digital (19.2 Kbps)		1	U/D	U/DL.19	\$35.92	\$250.99	\$176.03	\$116.85	\$27.85	\$10.89	\$22.00							
		4 Wire Unbundled Digital (19.2 Kbps)		2	U/D	U/DL.19	\$40.32	\$250.99	\$176.03	\$116.85	\$27.85	\$10.89	\$22.00							
		4 Wire Unbundled Digital (19.2 Kbps)		3	U/D	U/DL.19	\$37.9	\$250.99	\$176.03	\$116.85	\$27.85	\$10.89	\$22.00							
		4 Wire Unbundled Digital Loop 56 Kbps - Zone 1		1	U/D	U/DL.56	\$56.92	\$250.99	\$176.03	\$116.85	\$27.85	\$10.89	\$22.00							
		4 Wire Unbundled Digital Loop 56 Kbps - Zone 2		2	U/D	U/DL.56	\$40.32	\$250.99	\$176.03	\$116.85	\$27.85	\$10.89	\$22.00							
		4 Wire Unbundled Digital Loop 56 Kbps - Zone 3		3	U/D	U/DL.56	\$37.90	\$250.99	\$176.03	\$116.85	\$27.85	\$10.89	\$22.00							
		Order Coordination for Specified Conversion Time			U/D	O/COSL	\$36.18													
		4 Wire Unbundled Digital Loop 64 Kbps - Zone 1		1	U/D	U/DL.64	\$56.92	\$250.99	\$176.03	\$116.85	\$27.85	\$10.89	\$22.00							
		4 Wire Unbundled Digital Loop 64 Kbps - Zone 2		2	U/D	U/DL.64	\$40.32	\$250.99	\$176.03	\$116.85	\$27.85	\$10.89	\$22.00							
		4 Wire Unbundled Digital Loop 64 Kbps - Zone 3		3	U/D	U/DL.64	\$37.90	\$250.99	\$176.03	\$116.85	\$27.85	\$10.89	\$22.00							
		Order Coordination for Specified Conversion Time			U/D	O/COSL	\$36.18													
		2-WIRE UNBUNDLED COPPER LOOP																		
		2-Wire Unbundled Copper Loop/Short including manual service inquiry & facility reservation - Zone 1		1	U/L	U/L.PB	\$14.94	\$283.77	\$164.04	\$120.6	\$22.45	\$10.89	\$22.00							
		2-Wire Unbundled Copper Loop/Short including manual service inquiry & facility reservation - Zone 2		2	U/L	U/L.PB	\$15.15	\$283.77	\$164.04	\$120.6	\$22.45	\$10.89	\$22.00							

BELLSOUTH / ATT RATES
Unbundled Network Elements
KENTUCKY

CATEGORY	NOTES	Item#	Zone	BOS	USOC	Rate	RATES							OSS RATES												
							First	Advt	Discontin	Advt	SOmic	SOMan	SOMan	SOMan	SOMan	SOMan	SOMan	SOMan	SOMan							
4-WIRE COPPER LOOP	2-Wire Unbundled Copper Loop/Short including manual service inquiry and facility reservation - Zone 3 Order Coordination for Unbundled Copper Loops (per loop)		3	UCL	UCLPB	\$15.73	\$283.77	\$164.04	\$120.6	\$22.45	\$10.89	\$22.00														
						UCL	UCLMC	Nonrecurring																		
						\$14.94	\$203.39	\$127.56	\$100.89	\$15.88	\$10.89	\$22.00														
						2-Wire Unbundled Copper Loop/Short without manual service inquiry and facility reservation - Zone 1			1	UCL	UCLPW	\$15.15	\$203.39	\$127.56	\$100.89	\$15.88	\$10.89	\$22.00								
												UCL	UCLPW	Nonrecurring												
												\$15.73	\$203.39	\$127.56	\$100.89	\$15.88	\$10.89	\$22.00								
						2-Wire Unbundled Copper Loop/Short without manual service inquiry and facility reservation - Zone 2			2	UCL	UCLPW	\$15.73	\$203.39	\$127.56	\$100.89	\$15.88	\$10.89	\$22.00								
												UCL	UCLMC	Nonrecurring												
												\$36.19	\$270.38	\$160.65	\$120.6	\$22.45	\$10.89	\$22.00								
						2-Wire Unbundled Copper Loop/Long - includes manual svc. inquiry and facility reservation - Zone 1			1	UCL	UCL2L	\$49.31	\$270.38	\$150.65	\$120.6	\$22.45	\$10.89	\$22.00								
												UCL	UCL2L	Nonrecurring												
												\$80.78	\$270.38	\$150.65	\$120.6	\$22.45	\$10.89	\$22.00								
						2-Wire Unbundled Copper Loop/Long - includes manual svc. inquiry and facility reservation - Zone 2			2	UCL	UCL2L	\$49.31	\$270.38	\$150.65	\$120.6	\$22.45	\$10.89	\$22.00								
												UCL	UCL2L	Nonrecurring												
												\$80.78	\$270.38	\$150.65	\$120.6	\$22.45	\$10.89	\$22.00								
						2-Wire Unbundled Copper Loop/Long - includes manual svc. inquiry and facility reservation - Zone 3			3	UCL	UCL2L	\$49.31	\$270.38	\$150.65	\$120.6	\$22.45	\$10.89	\$22.00								
												UCL	UCLMC	Nonrecurring												
												\$36.19	\$270.38	\$160.65	\$120.6	\$22.45	\$10.89	\$22.00								
						2-Wire Unbundled Copper Loop/Long - without manual service inquiry and facility reservation - Zone 1			1	UCL	UCL2W	\$36.19	\$190.000	\$114.17	\$100.89	\$15.88	\$10.89	\$22.00								
												UCL	UCL2W	Nonrecurring												
												\$49.31	\$190.000	\$114.17	\$100.89	\$15.88	\$10.89	\$22.00								
						2-Wire Unbundled Copper Loop/Long - without manual service inquiry and facility reservation - Zone 2			2	UCL	UCL2W	\$36.19	\$190.000	\$114.17	\$100.89	\$15.88	\$10.89	\$22.00								
												UCL	UCL2W	Nonrecurring												
												\$49.31	\$190.000	\$114.17	\$100.89	\$15.88	\$10.89	\$22.00								
						2-Wire Unbundled Copper Loop/Long - without manual service inquiry and facility reservation - Zone 3			3	UCL	UCL2W	\$36.19	\$190.000	\$114.17	\$100.89	\$15.88	\$10.89	\$22.00								
												UCL	UCLMC	Nonrecurring												
												\$80.78	\$190.000	\$114.17	\$100.89	\$15.88	\$10.89	\$22.00								
						2-Wire Unbundled Copper Loop - Non-Designated - Zone 1			1	UCL	UCLMC	\$11.01	\$16.31	\$22.40	\$25.65	\$7.06	\$10.89	\$22.00								
												UCL	UCLMC	Nonrecurring												
												\$12.67	\$16.31	\$22.40	\$25.65	\$7.06	\$10.89	\$22.00								
2-Wire Unbundled Copper Loop - Non-Designated - Zone 2			2	UCL	UCLMC	\$12.67	\$16.31	\$22.40	\$25.65	\$7.06	\$10.89	\$22.00														
						UCL	UCLMC	Nonrecurring																		
						\$44.69	\$16.31	\$22.40	\$25.65	\$7.06	\$10.89	\$22.00														
2-Wire Unbundled Copper Loop - Non-Designated - Zone 3			3	UCL	UCLMC	\$12.67	\$16.31	\$22.40	\$25.65	\$7.06	\$10.89	\$22.00														
						UCL	UCLMC	Nonrecurring																		
						\$44.69	\$16.31	\$22.40	\$25.65	\$7.06	\$10.89	\$22.00														
Order Coordination for Unbundled Copper Loops (per loop)						\$16.31	\$16.31	\$16.31																		
						UCL	UCLMC	Nonrecurring																		
						\$28.76	\$28.76	\$28.76																		
Engineering Information Document						\$28.76	\$28.76	\$28.76																		
						UCL	UCLMC	Nonrecurring																		
						\$78.92	\$78.92	\$78.92																		
Loop Testing - Basic Half Hour						\$23.33	\$23.33	\$23.33																		
						UCL	UCLMC	Nonrecurring																		
						\$23.33	\$23.33	\$23.33																		
Loop Testing - Basic Additional Half Hour						\$23.33	\$23.33	\$23.33																		
						UCL	UCLMC	Nonrecurring																		
						\$23.33	\$23.33	\$23.33																		

CATEGORY	NOTES	UNBUNDLED NETWORK ELEMENT	Intram	Zone	BOS	USOC	Rat	RATES			OSS RATES													
								First	ADT	Disconn	ADT	SOMEC	SOMAN	SOMAN	SOMAN	SOMAN	SOMAN	SOMAN	SOMAN					
LOOP MODIFICATION	Unbundled Loop Modification, Removal of Load Coils - 2 Wire pair less than or equal to 18K ft.				UHL,UHL,UCL,UEQ	ULMPL	\$65.2	\$65.2																
	Unbundled Loop Modification, Removal of Load Coils - 2 Wire greater than 18K ft.				UCL	ULMPG	\$341.64	\$341.64																
	Unbundled Loop Modification Removal of Load Coils - 4 Wire less than or equal to 18K ft.				UHL, UCL	ULMPL	\$65.2	\$65.2																
	Unbundled Loop Modification Removal of Load Coils - 4 Wire pair greater than 18K ft.				UCL	ULMAG	\$341.64	\$341.64																
	Unbundled Loop Modification Removal of Bridged Tap Removal, per unbundled loop				UHL,UHL,UCL,UEQ,UEF	ULMBT	\$65.24	\$65.24																
SUB-LOOPS																								
Sub-Loop Distribution																								
	Sub-Loop - Per Cross Box Location - CLEC Feeder Facility Set-Up				UEANL	USBSA	\$600.03	\$600.03																
	Sub-Loop - Per Cross Box Location - Per 25 Pair Panel Set-Up				UEANL	USBSB	\$45.28	\$45.28																
	Sub-Loop - Per Building Equipment Room - CLEC Feeder Facility Set-Up				UEANL	USBSC	\$379.89	\$379.89																
	Sub-Loop - Per Building Equipment Room - Per 25 Pair Panel Set-Up				UEANL	USBSD	\$111.55	\$111.55																
	Sub-Loop Distribution Per 2-Wire Analog Voice Grade Loop - Zone 1			1	UEANL	USBNZ	\$9.03	\$131.64	\$61.93	\$90.83	\$13.44	\$10.89	\$22.00											
	Sub-Loop Distribution Per 2-Wire Analog Voice Grade Loop - Zone 2			2	UEANL	USBNZ	\$12.25	\$131.64	\$61.93	\$90.83	\$13.44	\$10.89	\$22.00											
	Sub-Loop Distribution Per 2-Wire Analog Voice Grade Loop - Zone 3			3	UEANL	USBNZ	\$16.71	\$131.64	\$61.93	\$90.83	\$13.44	\$10.89	\$22.00											
	Order Coordination for Unbundled Sub-Loops, per sub-loop pair				UEANL	USBNC	\$36.18	\$36.18																
	Sub-Loop Distribution Per 4-Wire Analog Voice Grade Loop - Zone 1			1	UEANL	USBM4	\$10.18	\$158.12	\$88.41	\$98.10	\$18.08	\$10.89	\$22.00											
	Sub-Loop Distribution Per 4-Wire Analog Voice Grade Loop - Zone 2			2	UEANL	USBM4	\$9.44	\$158.12	\$88.41	\$98.10	\$18.08	\$10.89	\$22.00											
	Sub-Loop Distribution Per 4-Wire Analog Voice Grade Loop - Zone 3			3	UEANL	USBM4	\$13.98	\$158.12	\$88.41	\$98.10	\$18.08	\$10.89	\$22.00											
	Order Coordination for Unbundled Sub-Loops, per sub-loop pair				UEANL	USBPC	\$32.3	\$108.06	\$36.26	\$90.83	\$13.44	\$10.89	\$19.99											
	Order Coordination for Unbundled Network Cable (NC)				UEANL	USBR4	\$6.29	\$36.18	\$36.18	\$99.10	\$18.08	\$10.89	\$19.99											
	Order Coordination for Unbundled Sub-Loops, per sub-loop pair			1	UEANL	USBR4	\$6.29	\$118.94	\$28.94	\$99.10	\$18.08	\$10.89	\$19.99											
	2 Wire Copper Unbundled Sub-Loop Distribution - Zone 1			1	UEF	USGSX	\$8.01	\$36.18	\$36.18	\$90.83	\$13.44	\$10.89	\$22.00											
	2 Wire Copper Unbundled Sub-Loop Distribution - Zone 2			2	UEF	USGSX	\$9.18	\$36.18	\$36.18	\$90.83	\$13.44	\$10.89	\$22.00											
	2 Wire Copper Unbundled Sub-Loop Distribution - Zone 3			3	UEF	USGSX	\$9.18	\$36.18	\$36.18	\$90.83	\$13.44	\$10.89	\$22.00											
	Order Coordination for Unbundled Sub-Loops, per sub-loop pair				UEF	USBMC	\$11.02	\$36.18	\$36.18	\$99.10	\$18.08	\$10.89	\$22.00											
	4 Wire Copper Unbundled Sub-Loop Distribution - Zone 1			1	UEF	USCS4X	\$10.65	\$158.12	\$88.41	\$98.10	\$18.08	\$10.89	\$22.00											
	4 Wire Copper Unbundled Sub-Loop Distribution - Zone 2			2	UEF	USCS4X	\$9.71	\$158.12	\$88.41	\$98.10	\$18.08	\$10.89	\$22.00											
	4 Wire Copper Unbundled Sub-Loop Distribution - Zone 3			3	UEF	USCS4X	\$8.45	\$158.12	\$88.41	\$98.10	\$18.08	\$10.89	\$22.00											
	Order Coordination for Unbundled Sub-Loops, per sub-loop pair				UEF	USBMC	\$36.18	\$36.18																
Sub-Loop Feeder																								
	USL-Feeder, DSO Set-up per Cross Box location - CLEC Distribution				UEA,UEANL,UEANL,UDL,UDC	USBRW	\$600.03	\$45.28	\$45.28															
	Facility set-up				UEA,UEANL,UEANL,UDL,UDC	USBRW	\$600.03	\$45.28	\$45.28															
	USL-Feeder, DSO Set-up per Cross Box location - per 25 pair set-up				USL,UEANL,UEANL,UDL,UDC	USBRF	\$527.98	\$11.32	\$11.32															
	Unbundled Sub-Loop Feeder Loop, 2 Wire Ground Start, Voice Grade-Zone 1			1	UEA	USBPA	\$10.36	\$184.97	\$111.91	\$108.76	\$26.76	\$10.89	\$22.00											
	Unbundled Sub-Loop Feeder Loop, 2 Wire Ground Start, Voice Grade-Zone 2			2	UEA	USBPA	\$13.82	\$184.97	\$111.91	\$108.76	\$26.76	\$10.89	\$22.00											
	Unbundled Sub-Loop Feeder Loop, 2 Wire Ground-Start Voice Grade-Zone 3			3	UEA	USBPA	\$19.89	\$184.97	\$111.91	\$108.76	\$26.76	\$10.89	\$22.00											
	Order Coordination for Specified Conversion Time, per ISR				UEA	OCCSL	\$36.18	\$36.18																
	Unbundled Sub-Loop Feeder Loop, 2 Wire Loop-Start, Voice Grade-Zone 1			1	UEA	USBRB	\$10.36	\$184.97	\$111.91	\$108.76	\$26.76	\$10.89	\$22.00											

BELL SOUTH / ATT RATES
Unbundled Network Elements
KENTUCKY

CATEGORY	NOTES	UNBUNDLED NETWORK ELEMENT	Intrm	Zone	BOS	USOC	Rec	RATES					OSS RATES					
								First	ADDT	Disconnect Fees	ADDT	SOMEC	SOMAN	SOMAN	SOMAN	SOMAN	SOMAN	SOMAN
		Unbundled Sub-Loop Feeder Loop, 2 Wire Loop-Start, Voice Grade - Zone 2		2	UEA	USBRB	\$13.62	\$184.97	\$111.91	\$108.76	\$26.76	\$10.89	\$22.00					
		Unbundled Sub-Loop Feeder Loop, 2 Wire Start Loop, Voice Grade - Zone 3		3	UEA	USBRB	\$19.69	\$184.97	\$111.91	\$108.76	\$26.76	\$10.89	\$22.00					
		Unbundled Sub-Loop Feeder Loop, 2 Wire Reverse Battery, Voice Grade - Zone 1		1	UEA	USBFC	\$10.36	\$184.97	\$111.91	\$108.76	\$26.76	\$10.89	\$22.00					
		Unbundled Sub-Loop Feeder Loop, 2 Wire Reverse Battery, Voice Grade - Zone 2		2	UEA	USBFC	\$13.62	\$184.97	\$111.91	\$108.76	\$26.76	\$10.89	\$22.00					
		Unbundled Sub-Loop Feeder Loop, 2 Wire Analog Reverse Battery, Voice Grade - Zone 3		3	UEA	USBFC	\$19.69	\$184.97	\$111.91	\$108.76	\$26.76	\$10.89	\$22.00					
		Order Coordination For Specified Conversion Time, per LSR																
		Unbundled Sub-Loop Feeder Loop, 4 Wire Ground-Start, Voice Grade - Zone 1		1	UEA	USBFD	\$30.69	\$213.56	\$138.6	\$122.64	\$33.64	\$10.89	\$22.00					
		Unbundled Sub-Loop Feeder Loop, 4 Wire Ground-Start, Voice Grade - Zone 2		2	UEA	USBFD	\$36.12	\$213.56	\$138.6	\$122.64	\$33.64	\$10.89	\$22.00					
		Unbundled Sub-Loop Feeder Loop, 4 Wire Ground-Start, Voice Grade - Zone 3		3	UEA	USBFD	\$22.90	\$213.56	\$138.6	\$122.64	\$33.64	\$10.89	\$22.00					
		Order Coordination For Specified Conversion Time, per LSR																
		Unbundled Sub-Loop Feeder Loop, 4 Wire Loop-Start, Voice Grade - Zone 1		1	UEA	USBFE	\$30.69	\$213.56	\$138.6	\$122.64	\$33.64	\$10.89	\$22.00					
		Unbundled Sub-Loop Feeder Loop, 4 Wire Loop-Start, Voice Grade - Zone 2		2	UEA	USBFE	\$36.12	\$213.56	\$138.6	\$122.64	\$33.64	\$10.89	\$22.00					
		Unbundled Sub-Loop Feeder Loop, 4 Wire Loop-Start, Voice Grade - Zone 3		3	UEA	USBFE	\$22.90	\$213.56	\$138.6	\$122.64	\$33.64	\$10.89	\$22.00					
		Order Coordination For Specified Conversion Time, per LSR																
		Unbundled Sub-Loop Feeder Loop, 2 Wire ISDN BRI - Zone 1		1	UDN	USBFE	\$17.75	\$221.3	\$136.34	\$111.02	\$26.01	\$10.89	\$22.00					
		Unbundled Sub-Loop Feeder Loop, 2 Wire ISDN BRI - Zone 2		2	UDN	USBFE	\$23.67	\$221.3	\$136.34	\$111.02	\$26.01	\$10.89	\$22.00					
		Unbundled Sub-Loop Feeder Loop, 2 Wire ISDN BRI - Zone 3		3	UDN	USBFE	\$29.90	\$221.3	\$136.34	\$111.02	\$26.01	\$10.89	\$22.00					
		Order Coordination For Specified Conversion Time, per LSR																
		Unbundled Sub-Loop Feeder Loop, 2 Wire UDC (DSL compatible)		1	UDN	USBFS	\$17.75	\$221.3	\$136.34	\$111.02	\$26.01	\$10.89	\$22.00					
		Unbundled Sub-Loop Feeder Loop, 2 Wire UDC (DSL compatible)		2	UDN	USBFS	\$23.67	\$221.3	\$136.34	\$111.02	\$26.01	\$10.89	\$22.00					
		Unbundled Sub-Loop Feeder Loop, 2 Wire UDC (DSL compatible)		3	UDN	USBFS	\$29.90	\$221.3	\$136.34	\$111.02	\$26.01	\$10.89	\$22.00					
		Order Coordination For Specified Conversion Time, per LSR																
		Unbundled Sub-Loop Feeder Loop, 4 Wire DSL - Zone 1		1	USL	USBFG	\$25.1	\$202.14	\$127.18	\$122.64	\$33.64	\$10.89	\$22.00					
		Unbundled Sub-Loop Feeder Loop, 4 Wire DSL - Zone 2		2	USL	USBFG	\$31.53	\$202.14	\$127.18	\$122.64	\$33.64	\$10.89	\$22.00					
		Unbundled Sub-Loop Feeder Loop, 4 Wire DSL - Zone 3		3	USL	USBFG	\$36.18	\$202.14	\$127.18	\$122.64	\$33.64	\$10.89	\$22.00					
		Order Coordination For Specified Conversion Time, per LSR																
		Unbundled Sub-Loop Feeder Loop, 2 Wire Copper Loop - Zone 1		1	UCL	USBHH	\$8.29	\$187.62	\$92.66	\$108.42	\$21.41	\$10.89	\$22.00					
		Unbundled Sub-Loop Feeder Loop, 2 Wire Copper Loop - Zone 2		2	UCL	USBHH	\$7.50	\$187.62	\$92.66	\$108.42	\$21.41	\$10.89	\$22.00					
		Unbundled Sub-Loop Feeder Loop, 2 Wire Copper Loop - Zone 3		3	UCL	USBHH	\$6.09	\$187.62	\$92.66	\$108.42	\$21.41	\$10.89	\$22.00					
		Order Coordination For Specified Conversion Time, per LSR																
		Unbundled Sub-Loop Feeder Loop, 4 Wire Copper Loop - Zone 1		1	UCL	OCOSL	\$16.55	\$202.05	\$127.09	\$115.43	\$26.43	\$10.89	\$22.00					
		Unbundled Sub-Loop Feeder Loop, 4 Wire Copper Loop - Zone 2		2	UCL	OCOSL	\$15.35	\$202.05	\$127.09	\$115.43	\$26.43	\$10.89	\$22.00					
		Unbundled Sub-Loop Feeder Loop, 4 Wire Copper Loop - Zone 3		3	UCL	OCOSL	\$12.92	\$202.05	\$127.09	\$115.43	\$26.43	\$10.89	\$22.00					
		Order Coordination For Specified Conversion Time, per LSR																
		Unbundled Sub-Loop Feeder Loop, 19.2 Kbps Digital Grade Loop		1	UDL	USBPN	\$27.38	\$202.14	\$127.18	\$122.64	\$33.64	\$10.89	\$22.00					
		Unbundled Sub-Loop Feeder Loop, 19.2 Kbps Digital Grade Loop		2	UDL	USBPN	\$33.41	\$202.14	\$127.18	\$122.64	\$33.64	\$10.89	\$22.00					
		Unbundled Sub-Loop Feeder Loop, 19.2 Kbps Digital Grade Loop		3	UDL	USBPN	\$24.47	\$202.14	\$127.18	\$122.64	\$33.64	\$10.89	\$22.00					
		Order Coordination For Specified Conversion Time, per LSR																
		Unbundled Sub-Loop Feeder Loop, 56 Kbps Digital Grade Loop - Zone 1		1	UDL	USBFO	\$27.38	\$202.14	\$127.18	\$122.64	\$33.64	\$10.89	\$22.00					
		Unbundled Sub-Loop Feeder Loop, 56 Kbps Digital Grade Loop - Zone 2		2	UDL	USBFO	\$33.41	\$202.14	\$127.18	\$122.64	\$33.64	\$10.89	\$22.00					
		Unbundled Sub-Loop Feeder Loop, 56 Kbps Digital Grade Loop - Zone 3		3	UDL	USBFO	\$24.47	\$202.14	\$127.18	\$122.64	\$33.64	\$10.89	\$22.00					
		Order Coordination For Specified Time Conversion, per LSR																
		Sub-Loop Feeder - Per 4-Wire 64 Kbps Digital Grade Loop - Zone 1		1	UDL	USBFP	\$27.38	\$202.14	\$127.18	\$122.64	\$33.64	\$10.89	\$22.00					
		Sub-Loop Feeder - Per 4-Wire 64 Kbps Digital Grade Loop - Zone 2		2	UDL	USBFP	\$33.41	\$202.14	\$127.18	\$122.64	\$33.64	\$10.89	\$22.00					
		Sub-Loop Feeder - Per 4-Wire 64 Kbps Digital Grade Loop - Zone 3		3	UDL	USBFP	\$24.47	\$202.14	\$127.18	\$122.64	\$33.64	\$10.89	\$22.00					
		Order Coordination For Specified Conversion Time, per LSR																
		Unbundled Sub-Loop Modification																

BELLSOUTH / ATT RATES
Unbundled Network Elements
KENTUCKY

CATEGORY	NOTES	UNBUNDLED NETWORK ELEMENT	Intrm	Zone	BOS	USOC	Rec	RATES				OSS RATES										
								First	ADT	Disconn	ADT	SOMEC	SOMAN	SOMAN	SOMAN	SOMAN	SOMAN	SOMAN	SOMAN			
								Nonrecurring		Nonrecurring			See Order Submitted Manually per LSR	See Order Submitted Manually per LSR	Incremental Change - Manual Charge - Manual Charge - 1st Electronic-1st	Incremental Change - Manual Charge - Manual Charge - 1st Electronic-Add1	Incremental Change - Manual Charge - Manual Charge - 1st Electronic-Dis1	Incremental Change - Manual Charge - Manual Charge - 1st Electronic-Add1				
		Unbundled Sub-Loop Modification - 2-W Copper Dist Load Coil/Equip Removal per 2-W PR			UEF	ULM2X																
		Unbundled Sub-Loop Modification - 4-W Copper Dist Load Coil/Equip Removal per 4-W PR			UEF	ULM4X																
		Unbundled Sub-Loop Modification - 2-w/4-w Copper Dist Bridged Tap Removal, per PR unbanded			UEF	ULM4T																
		Unbundled Network Terminating Wire (UNTW) per Pair			UENTW	UENPP		\$0.64		\$62.83		\$62.83			\$10.89	\$22.00				\$3.94	\$3.94	
		Network Interface Device (NID)																				
		Network Interface Device (NID) - 1-2 lines			UENTW	UNID12				\$89.66		\$57.24									\$3.94	\$3.94
		Network Interface Device (NID) - 1-6 lines			UENTW	UNID16				\$129.24		\$99.52									\$3.94	\$3.94
		Network Interface Device Cross Connect - 2-W			UENTW	UNIDC2				\$11.78		\$11.78			\$10.89	\$22.00				\$3.94	\$3.94	
		Network Interface Device Cross Connect - 4W			UENTW	UNIDC4				\$11.78		\$11.78			\$10.89	\$22.00				\$3.94	\$3.94	
		UNBUNDLED LOOP CONCENTRATION																				
		Unbundled Loop Concentration - System A (TR008)			UIC	UIC78A		\$522.17		\$651.04		\$651.04										
		Unbundled Loop Concentration - System B (TR008)			UIC	UIC78B		\$63.59		\$271.27		\$271.27										
		Unbundled Loop Concentration - System A (TR303)			UIC	UIC78A		\$67.21		\$651.04		\$651.04										
		Unbundled Loop Concentration - System B (TR303)			UIC	UIC78B		\$107.76		\$271.27		\$271.27										
		Unbundled Loop Concentration - DS1 Loop Interface Card			UIC	UIC78		\$63.04		\$26.61		\$26.61			\$9.37							
		Unbundled Loop Concentration - USN Loop Interface (Brite Card)			UDC	UDC71		\$9.59		\$20.96		\$20.96			\$10.75							
		Unbundled Loop Concentration - UDC Loop Interface (Brite Card)			UDC	UDC71		\$9.59		\$20.96		\$20.96			\$10.75							
		Unbundled Loop Concentration - 2 Wire Voice-Loop Start or Ground Start Loop Interface (POTS Card)			UEA	UEA72		\$2.40		\$20.96		\$20.96			\$10.75							
		Unbundled Loop Concentration - 2 Wire Voice - Reverse Battery Loop Interface (SPOIS Card)			UEA	UEA72R		\$14.26		\$20.96		\$20.96			\$10.68							
		Unbundled Loop Concentration - 4 Wire Voice Loop Interface			UEA	UEA74		\$8.51		\$21.08		\$21.08			\$10.75							
		Unbundled Loop Concentration - TEST CIRCUIT Card			UIC	UIC77C		\$41.58		\$20.96		\$20.96			\$10.68							
		Unbundled Loop Concentration - Digital 19.2 Kbps Data Loop Interface			UDL	ULC7		\$12.6		\$21.08		\$20.96			\$10.75							
		Unbundled Loop Concentration - Digital 56 Kbps Data Loop Interface			UDL	ULC5		\$12.60		\$21.08		\$20.96			\$10.68						\$3.94	\$3.94
		Unbundled Loop Concentration - Digital 64 Kbps Data Loop Interface			UDL	ULC6		\$12.60		\$21.08		\$20.96			\$10.75						\$3.94	\$3.94
		UNBUNDLED SUB-LOOP CONCENTRATION (OUTSIDE CO)																				
		UNE OTHER - PROVISIONING ONLY - NO RATE																				
		NID - Dispatch and Service Order for NID Installation			UENTW	UNDBX																
		UNTW Circuit Id Establishment, Provisioning Only - No Rate			UEANL,UEF,UEQ,UE	UENCE																
		Unbundled Contract Name, Provisioning Only - No Rate			UENTW	UNEON																
		Unbundled Contract Name, Provisioning Only - No Rate			UENTW	UNEON																
		Unbundled Contact Name, Provisioning Only - no rate			UDL,UCL,UDC,UDL,U	UNEON		\$0.0		\$0.0		\$0.0										
		Unbundled Sub-Loop Feeder-2 Wire Cross Box Jumper - no rate			UEA,UDN,UCL,UDC	USBF0		\$0.0		\$0.0		\$0.0										
		Unbundled Sub-Loop Feeder-4 Wire Cross Box Jumper - no rate			UEA,USL,UCL,UDL	USBF0		\$0.0		\$0.0		\$0.0										
		Unbundled DS1 Loop - Superframe Format Option - no rate			USL	COOSF		\$0.0		\$0.0		\$0.0										
		Unbundled DS1 Loop - Expanded Superframe Format option - no rate			USL	COOEF		\$0.0		\$0.0		\$0.0										
		HIGH CAPACITY UNBUNDLED LOCAL LOOP																				
		NOTE: 4 month minimum billing period																				
		High Capacity Unbundled Local Loop - DS3 - Per Mile per month			UE3	1L5ND		\$11.53														
		High Capacity Unbundled Local Loop - DS3 - Facility Termination per month			UE3	UE3PX		\$379.72		\$903.37		\$528.05			\$10.9	\$31.32					\$3.94	\$3.94
		High Capacity Unbundled Local Loop - STS-1 - Per Mile per month			UDLSX	1L5ND		\$11.53														
		High Capacity Unbundled Local Loop - STS-1 - Facility Termination per month			UDLSX	UDLS1		\$394.76		\$903.34		\$528.05			\$10.9	\$31.32					\$3.94	\$3.94

BELLSOUTH / ATT RATES
Unbundled Network Elements
KENTUCKY

CATEGORY	NOTES	UNBUNDLED NETWORK ELEMENT	Intrm	Zone	BOS	USOC	Rec	RATES				OSS RATES							
								First	Advt	Disconn	Advt	SOMEC	SOMAN	SOMAN	SOMAN	SOMAN	SOMAN	SOMAN	
								Nonrecurring		Nonrecurring			Site Order Submitted Manually per LSR	Site Order Submitted Manually per LSR	Incremental Change - Manual Charge - Electronic-1st	Incremental Change - Manual Charge - Electronic-Add1	Incremental Change - Manual Charge - Electronic-1st	Incremental Change - Manual Charge - Electronic-Add1	
LOOP MAKE-UP	Loop Makeup - Preordering Without Reservation, per working or spare facility queried (Manual) - **																		
	Loop Makeup - Preordering With Reservation, per spare facility queried (Manual) - **				UMK			\$47.98		\$47.98									
	Loop Makeup-With or Without Reservation, per working or spare facility queried (Mechanized) **				UMK			\$50.88		\$50.88									
								\$0.6746		\$0.6746									
LINE SHARING																			
	Line Sharing Splitter, per System 96 Line Capacity				U.S			\$203.33		\$377.71									
	Line Sharing Splitter, per System 24 Line Capacity				U.S			\$50.83		\$377.71									
	Line Sharing - per Line Activation				U.S			\$0.61		\$37.02									
	Line Sharing - per Subsequent Activity per Line Rearrangement				U.S			\$32.78		\$16.38									
	Line Sharing-CLEC/DLEC Owned Splitter in CO-per occurrence of each group of 24 lines (48 pi)				U.S					\$57.72									
UNBUNDLED TRANSPORT																			
	COMMON TRANSPORT (Shared)																		
	Common Transport - Per Mile, Per MOU							\$0.0000049											
	Common Transport - Facilities Termination Per MOU							\$0.000426											
	NOTE: INTEROFFICE CHANNEL - DEDICATED TRANSPORT - minimum billing period below DSS = one month, DSS and above four months																		
INTEROFFICE CHANNEL - DEDICATED TRANSPORT - VOICE GRADE																			
	Introffice Channel - Dedicated Transport - 2-Wire Voice Grade - Per Mile per month				U1TVX			\$0.0118											
	Introffice Channel - Dedicated Transport - 2-Wire Voice Grade - Facility Termination per month				U1TVX			\$29.51		\$81.07									
	Introffice Channel - Dedicated Transport - 2-Wire Voice Grade Rev Bat. - Per Mile per month				U1TVX			\$0.0118											
	Introffice Channel - Dedicated Transport - 2-Wire VG Rev Bat. - Facility Termination per month				U1TVX			\$29.51		\$81.07									
	Introffice Channel - Dedicated Transport - 4-Wire Voice Grade - Per Mile per month				U1TVX			\$0.0118											
	Introffice Channel - Dedicated Transport - 4-Wire Voice Grade - Facility Termination per month				U1TVX			\$29.51		\$81.1									
	Introffice Channel - Dedicated Transport - 56 kbps - per mile per month				U1TDX			\$0.0118											
	Introffice Channel - Dedicated Transport - 56 kbps - Facility Termination per month				U1TDX			\$29.51		\$81.1									
	Introffice Channel - Dedicated Transport - 64 kbps - per mile per month				U1TDX			\$0.0118											
	Introffice Channel - Dedicated Transport - 64 kbps - Facility Termination per month				U1TDX			\$29.51		\$81.10									
INTEROFFICE CHANNEL - DEDICATED TRANSPORT - DSI																			
	Introffice Channel - Dedicated Channel - DSI - Per Mile per month				U1TD1			\$0.2407											
	Introffice Channel - Dedicated Transport - DSI - Facility Termination per month				U1TD1			\$97.38		\$178.53									
INTEROFFICE CHANNEL - DEDICATED TRANSPORT - DSS																			
	Introffice Channel - Dedicated Transport - DSS - Per Mile per month				U1TD3			\$5.1											
	Introffice Channel - Dedicated Transport - DSS - Facility Termination per month				U1TD3			\$1,191.53		\$557.49									
INTEROFFICE CHANNEL - DEDICATED TRANSPORT - STS-1																			
	Introffice Channel - Dedicated Transport - STS-1 - Per Mile per month				U1TS1			\$5.1											

BELLSOUTH / ATT RATES
Unbundled Network Elements
KENTUCKY

CATEGORY	NOTES	UNBUNDLED NETWORK ELEMENT	Interim	Zone	BOS	USOC	RATES								OSS RATES							
							Rec	First	ADDT	Discontin	ADDT	SOMECC	SOMAN	SOMAN	SOMAN	SOMAN	SOMAN	SOMAN	SOMAN	SOMAN	SOMAN	SOMAN
LOCAL CHANNE	NOTE: LOCAL CHANNE DEDICATED TRANSPORT - minimum billing period - below DS3=one month, DS3 and above=four months	LOCAL CHANNE - Dedicated - 2-Wire Voice Grade Rev Bat per month					\$18.18	\$386.53	\$66.35	\$73.28	\$6.37	\$10.89	\$31.32	\$31.32	\$31.32	\$31.32	\$31.32	\$31.32	\$31.32	\$31.32	\$31.32	
		Local Channel - Dedicated - 4-Wire Voice Grade per month			ULCVX	ULDR2	\$18.18	\$386.53	\$66.35	\$73.28	\$6.37	\$10.89	\$31.32	\$31.32	\$31.32	\$31.32	\$31.32	\$31.32	\$31.32	\$31.32	\$31.32	
		Local Channel - Dedicated - DS1 per month - Zone 1			UNCVX	ULDV4	\$20.12	\$387.22	\$67.22	\$73.98	\$7.31	\$10.89	\$31.32	\$31.32	\$31.32	\$31.32	\$31.32	\$31.32	\$31.32	\$31.32	\$31.32	
		Local Channel - Dedicated - DS1 per month - Zone 2			ULDD1	ULDF1	\$44.63	\$355.06	\$97.53	\$44.24	\$30.42	\$10.89	\$31.32	\$31.32	\$31.32	\$31.32	\$31.32	\$31.32	\$31.32	\$31.32	\$31.32	
		Local Channel - Dedicated - DS1 per month - Zone 3			ULDD1	ULDF1	\$40.74	\$355.06	\$44.63	\$307.53	\$44.24	\$10.89	\$31.32	\$31.32	\$31.32	\$31.32	\$31.32	\$31.32	\$31.32	\$31.32	\$31.32	
		Local Channel - Dedicated - DS3 - Per Mile per month			ULDD3	ULDF3	\$42.95	\$355.06	\$307.53	\$44.24	\$30.42	\$10.89	\$31.32	\$31.32	\$31.32	\$31.32	\$31.32	\$31.32	\$31.32	\$31.32	\$31.32	
		Local Channel - Dedicated - STS-1 - Per Mile per month			ULDD3	ULDF3	\$83.57	\$903.34	\$528.05	\$238.2	\$168.62	\$10.89	\$31.32	\$31.32	\$31.32	\$31.32	\$31.32	\$31.32	\$31.32	\$31.32	\$31.32	
		Local Channel - Dedicated - STS-1 - Per Mile per month			ULDS1	ULDS3	\$8.98	\$15.9C	\$8.98	\$583.57	\$528.05	\$10.89	\$31.32	\$31.32	\$31.32	\$31.32	\$31.32	\$31.32	\$31.32	\$31.32	\$31.32	
		Local Channel - Dedicated - STS-1 - Facility Termination per month			ULDS1	ULDS3	\$550.34	\$903.34	\$583.57	\$528.05	\$238.2	\$10.89	\$31.32	\$31.32	\$31.32	\$31.32	\$31.32	\$31.32	\$31.32	\$31.32	\$31.32	
		Channelization - DS1 to DS0 Channel System			UXTD1	MC1	\$139.65	\$182.08	\$125.19	\$21	\$19.52	\$10.89	\$31.32	\$31.32	\$31.32	\$31.32	\$31.32	\$31.32	\$31.32	\$31.32	\$31.32	
		OCU-DP COCI (date) - DS1 to DS0 Channel System - per month (2-4 64kbs)			UDL	1D1DD	\$1.63	\$13.16	\$9.43													
		Voice Grade COCI - DS1 to DS0 Channel System - per month			UDN	1C1CA	\$23.5	\$13.16	\$9.43													
		DS3 to DS1 Channel System per month			UXTD3	1D1VG	\$0.7676	\$13.16	\$9.43													
		STS1 to DS1 Channel System per month			UXTS1	MC3	\$194.82	\$356.4	\$188.00	\$66.3	\$65.44	\$10.89	\$31.32	\$31.32	\$31.32	\$31.32	\$31.32	\$31.32	\$31.32	\$31.32	\$31.32	
		DS3 Interface Unit (DS1 COCI) used with Loop per month			USL	UC1D1	\$14.53	\$13.16	\$9.43													
		DARK FIBER																				
		Dark Fiber, Four Fiber Strands, Per Route Mile or Fraction Thereof per month - Local Channel			UDF	1LSDC	\$48.00	\$1,278.61	\$275.83	\$632.07	\$394.05	\$10.89	\$31.32	\$31.32	\$31.32	\$31.32	\$31.32	\$31.32	\$31.32	\$31.32	\$31.32	
		Dark Fiber, Four Fiber Strands, Per Route Mile or Fraction Thereof per month - Interface Channel			UDF	UDF-CA																
		Dark Fiber, Four Fiber Strands, Per Route Mile or Fraction Thereof per month - Dark Fiber - Interface Channel			UDF	1LSDF	\$31.51	\$1,278.61	\$275.83	\$632.07	\$394.05	\$10.89	\$31.32	\$31.32	\$31.32	\$31.32	\$31.32	\$31.32	\$31.32	\$31.32	\$31.32	
		Dark Fiber, Four Fiber Strands, Per Route Mile or Fraction Thereof per month - Local Loop			UDF	1LSDL	\$48.00	\$1,278.61	\$275.83	\$632.07	\$394.05	\$10.89	\$31.32	\$31.32	\$31.32	\$31.32	\$31.32	\$31.32	\$31.32	\$31.32	\$31.32	
		NRC Dark Fiber - Local Loop			UDF	UDF-L4																
		Optional Features & Functions:																				
		Clear Channel Capability (BZSESEF) Option - Subsequent - per DS1 Channel			UNC1X	COOEF	\$184.91	\$23.82	\$1.99	\$0.78	\$10.89	\$31.32	\$31.32	\$31.32	\$31.32	\$31.32	\$31.32	\$31.32	\$31.32	\$31.32	\$31.32	
		Clear Channel Capability (BZSSEF) Option - Subsequent - per DS1 Channel			UNC1X	COOSF	\$184.91	\$23.82	\$1.99	\$0.78	\$10.89	\$31.32	\$31.32	\$31.32	\$31.32	\$31.32	\$31.32	\$31.32	\$31.32	\$31.32	\$31.32	
		8XX Access Ten Digit Screening - Per Call			OHD																	
		8XX Access Ten Digit Screening - Reservation Charge Per 8XX Number Reserved			OHD	NBR1X	\$10.05	\$1.19	\$1.19			\$10.89	\$31.32	\$31.32	\$31.32	\$31.32	\$31.32	\$31.32	\$31.32	\$31.32	\$31.32	
		8XX Access Ten Digit Screening - Per 8XX No. Established W/O POTS Transitions			OHD		\$90.59	\$3.22	\$3.22			\$10.89	\$31.32	\$31.32	\$31.32	\$31.32	\$31.32	\$31.32	\$31.32	\$31.32	\$31.32	
		8XX Access Ten Digit Screening - Per 8XX No. Established With POTS Transitions			OHD	NBFTX	\$90.59	\$3.22	\$3.22			\$10.89	\$31.32	\$31.32	\$31.32	\$31.32	\$31.32	\$31.32	\$31.32	\$31.32	\$31.32	
		8XX Access Ten Digit Screening - Customized Area of Service Per 8XX Number			OHD	NBFCX	\$6.97	\$3.49	\$3.49			\$10.89	\$31.32	\$31.32	\$31.32	\$31.32	\$31.32	\$31.32	\$31.32	\$31.32	\$31.32	
		8XX Access Ten Digit Screening - Multiple Inlet LATA CXR Routing Per CXR Requested Per 8XX No			OHD	NBFAFX	\$8.16	\$4.67	\$4.67			\$10.89	\$31.32	\$31.32	\$31.32	\$31.32	\$31.32	\$31.32	\$31.32	\$31.32	\$31.32	
		8XX Access Ten Digit Screening - Change Charge Per Request			OHD	NBFAX	\$11.24	\$1.19	\$1.19			\$10.89	\$31.32	\$31.32	\$31.32	\$31.32	\$31.32	\$31.32	\$31.32	\$31.32	\$31.32	

BELLSOUTH / ATT RATES
Unbundled Network Elements
KENTUCKY

CATEGORY	NOTES	UNBUNDLED NETWORK ELEMENT	Intrm	Zone	BOS	USOC	Rec	RATES				OSS RATES									
								First	Advt	Disconn	Advt	SOMEC	SOMAN	SOMAN	SOMAN	SOMAN	SOMAN	SOMAN			
		8XX Access Ten Digit Screening, Call Handling and Destination Features			OHD	NBFDX		Nonrecurring	\$6.97												
		LINE INFORMATION DATA BASE ACCESS (LIDB)				OQT OQU	\$0.00006 \$0.00938		\$107.60												
		LIDB Common Transport Per Query																			
		LIDB Validation Per Query																			
		LIDB Originating Point Code Establishment or Change																			
		SIGNALING (CCS7)																			
		CCS7 Signaling Termination, Per STP Port					\$174.08														
		CCS7 Signaling Usage, Per TCAP Message					\$0.000102042														
		CCS7 Signaling Connection, Per Link (A link)					\$16.31		\$364.95		\$364.95										
		CCS7 Signaling Usage, Per ISUP Message					\$0.000037893														
		CCS7 Signaling Usage Surrogate, per link per LATA					\$329.98														
		CCS7 Signaling Point Code, Establishment or Change, per STP affected							\$62.00		\$62.00										
		CALLING NAME (CNAM) SERVICE																			
		CNAM for DB Owners, Per Query					\$0.016														
		CNAM for Non DB Owners, Per Query					\$0.01														
		CNAM (Non-Databs Owner), NRC, applies when using the Character Based User Interface (CHUI)																			
		OPERATOR SERVICES AND DIRECTORY ASSISTANCE																			
		OPERATOR CALL PROCESSING																			
		Oper. Call Processing - Oper. Provided, Per Min. - Using BST LIDB					\$1.2														
		Oper. Call Processing - Oper. Provided, Per Min. - Using Ecclen LIDB					\$1.24														
		Oper. Call Processing - Fully Automated, per Call - Using BST LIDB					\$0.20														
		Oper. Call Processing - Fully Automated, per Call - Using Foreign LIDB					\$0.20														
		INWARD OPERATOR SERVICES																			
		Inward Operator Services - Verification, Per Call					\$1.00														
		Inward Operator Services - Verification and Emergency Interrupt - Per Call					\$1.95														
		BRANDING - OPERATOR CALL PROCESSING																			
		Recording of Custom Branded OA Announcement							\$7,000.00		\$7,000.00										
		Loading of Custom Branded OA Announcement per shell/NAV							\$500.00		\$500.00										
		DIRECTORY ASSISTANCE SERVICES																			
		DIRECTORY ASSISTANCE ACCESS SERVICE																			
		Directory Assistance Access Service Calls, Charge Per Call					\$0.275														
		DIRECTORY ASSISTANCE CALL COMPLETION ACCESS SERVICE (DAOC)																			
		Directory Assistance Call Completion Access Service (DAOC), Per Call Attempt					\$0.10														
		UNBRANDING																			
		DIRECTORY TRANSPORT																			
		Directory Transport - Local Channel DS1					\$36.32		\$637.46		\$546.94										
		Directory Transport - DST Level Interoffice Per Mile					\$0.49				\$231.18										
		Directory Transport - DST Level Interoffice Per Facility Termination					\$35.05		\$298.18												
		Switched Common Transport Per DA Access Service Per Call					\$0.000175														
		Switched Common Transport Per DA Access Service Per Call Per Mile					\$0.000004														
		Access Tandem Switching Per DA Access Service Per Call					\$0.000783														
		Directory Transport - Installation NRC, Per Trunk or Signaling Connection							\$901.98		\$13.32										
		DIRECTORY ASSISTANCE DATA BASE SERVICE (DADB)																			

BELLSOUTH / ATT RATES
Unbundled Network Elements
KENTUCKY

CATEGORY	NOTES	UNBUNDLED NETWORK ELEMENT	Intrm	Zone	BGS	USOC	Rec	RATES				OSS RATES									
								Nonrecurring	First	Advt	Discontin	Nonrecurring	Advt	SOMEC	SOMAN	SOMAN	SOMAN	SOMAN	SOMAN		
		Directory Assistance Data Base Service Charge Per Listing					\$0.04														
		Directory Assistance Data Base Service, per month					\$150.00														
		BRANDING - DIRECTOR ASSISTANCE																			
		Custom Branding Announcement, per Recording to be used with the provision of DA			AMT					\$3,000.00		\$3,000.00									
		Loading of Custom Branded Announcement per DRAM Card/Switch			AMT					\$690.00		\$690.00									
		SELECTIVE ROUTING																			
		Selective Routing Per Unique Line Class Code Per Request Per Switch								\$229.66		\$229.66									
		VIRTUAL COLLOCATION																			
		Virtual Collocation - 2-wire Cross Connects (loop)			uean ueaa,ueah,ueca ueal,ueh uei,ueq					\$0.31		\$54.21									
		Virtual Collocation - 2-wire Cross Connects (port)			ueah,ueh uei,ueid					\$0.31		\$51.07									
		Virtual Collocation - 4-wire Cross Connects (loop)			ueaa,ueh uei,ueid					\$0.82		\$54.23									
		Virtual Collocation - 4-wire Cross Connects (port)			VE1R4					\$0.82		\$50.96									
		Virtual Collocation - 2-Fiber Cross Connects			CNCA2F					\$15.64		\$41.56									
		Virtual Collocation - 4-Fiber Cross Connects			CNCA4F					\$28.11		\$50.53									
		Virtual Collocation - DSI Cross Connects			USJLJC					\$1.50		\$44.07									
		AIN SELECTIVE CARRIER ROUTING																			
		Regional Service Establishment			SRC					\$391.788.00		\$391.788.00									
		End Office Establishment			SRC					\$20.53		\$20.53									
		Line-Port NRC, per end user			SRC					\$2.06		\$2.06									
		Query NRC, per query			SRC					\$0.000448		\$0.000448									
		AIN - BELLSOUTH AIN SMS ACCESS SERVICE																			
		AIN - BELLSOUTH AIN TOOLKIT SERVICE																			
		ODUF/EDU/ADU/FC/MS																			
		ACCESS DAILY USAGE FILE (ADUF)																			
		ADUF - Message Processing, per message								\$0.0009045		\$0.0009045									
		ADUF - Data Transmission (CONNECT-DIRECT), per message								\$0.00012942		\$0.00012942									
		ENHANCED OPTIONAL DAILY USAGE FILE (EODUF)																			
		EODUF - Message Processing, per message								\$0.253134		\$0.253134									
		OPTIONAL DAILY USAGE FILE (ODUF)																			
		ODUF - Recording, per message								\$ 0.000152		\$ 0.000152									
		ODUF - Message Processing, per message								\$0.0046890		\$0.0046890									
		ODUF - Message Processing, per Magnetic Tape provisioned								\$48.78		\$48.78									
		ODUF - Data Transmission (CONNECT-DIRECT), per message								\$0.00010756		\$0.00010756									
		ENHANCED EXTENDED LINK (EELS)																			
		NOTE: New EELs available in State of Georgia, density zone 1 of following SMSs: Orlando, FL; Miami, FL; Ft. Lauderdale, FL; Nashville, TN; New Orleans, LA.																			
		NOTE: Charlotte-Gastonia-Rockhill, NC; Greensboro-Winston Salem-High Point, NC. Use all rates below except Switch As is Charge.																			
		NOTE: In all states, EEL network elements shown below also apply to currently combined facilities which are converted to UNE rates. A Switch As is Charge applies to currently combined facilities converted to UNEs. (Non-recurring rates do not apply.)																			
		NOTE: In Georgia, the EEL network elements apply to ordinarily combined network elements per the GA PSC order. (No Switch As is Charge)																			

BELLSOUTH / ATT RATES
Unbundled Network Elements
KENTUCKY

CATEGORY	NOTES	UNBUNDLED NETWORK ELEMENT	Interim	Zone	BGS	USOC	Rec	RATES				OSS RATES									
								First	Advt	Disconn	Advt	SOMEC	SOMAN	SOMAN	SOMAN	SOMAN	SOMAN	SOMAN			
2-WIRE VOICE GRADE EXTENDED LOOP WITH DEDICATED DS1 INTEROFFICE TRANSPORT (EEL)	First 2-Wire VG Loop(SL2)/DS1 Interoffice Transport Combination - Zone 1			1	UNCVX	UEAL2	\$17.78														
	First 2-Wire VG Grade Loop(SL2)/DS1 Interoffice Transport			2	UNCVX	UEAL2	\$23.96														
	First 2-Wire VG Grade Loop(SL2)/DS1 Interoffice Transport Combination - Zone 2			3	UNCVX	UEAL2	\$34.96														
	First 2-Wire VG Grade Loop(SL2)/DS1 Interoffice Transport Combination - Zone 3				UNCVX	UEAL2	\$34.96														
	Interoffice Transport - Dedicated - DS1 combination - Per Mile per month				UNCVX	1L5XX	\$0.2407														
	Interoffice Transport - Dedicated - DS1 combination - Facility Termination per month				UNCVX	UTTF1	\$97.38														
	DS1 Channelization System Per Month				UNCVX	MO1	\$139.65														
	Voice Grade COCI - DS1 To DS0 Interface - Per Month				UNCVX	1D1VG	\$0.7676														
	Each Additional 2-Wire VG Loop(SL2) in the same DS1 Interoffice Transport Combination - Zone 1				UNCVX	UEAL2	\$17.78														
	Each Additional 2-Wire VG Loop(SL2) in the same DS1 Interoffice Transport Combination - Zone 2				UNCVX	UEAL2	\$23.96														
Each Additional 2-Wire VG Loop(SL2) in the same DS1 Interoffice Transport Combination - Zone 3				UNCVX	UEAL2	\$34.96															
Voice Grade COCI - DS1 to DS0 Channel System combination - per month				UNCVX	1D1VG	\$0.7676															
Nonrecurring Currently Combined Network Elements Switch -As-Is Change				UNCVX	UNCCC	\$11.19															
2-Wire VG Loop/Dedicated DS1 Interoffice Combination					UNCVX	UNCCC	\$11.19	\$11.19	\$13.91	\$161.68	\$13.91	\$13.91	\$10.89	\$33.63	\$27.49	\$19.88	\$11.85				
Nonrecurring Cost-new							\$625.52	\$342.39	\$161.68	\$49.26											
4-WIRE VOICE GRADE EXTENDED LOOP WITH DEDICATED DS1 INTEROFFICE TRANSPORT (EEL)																					
First 4-Wire Analog Voice Grade Loop/DS1 Interoffice Transport Combination - Zone 1				1	UNCVX	UEAL4	\$38.65														
First 4-Wire Analog Voice Grade Loop/DS1 Interoffice Transport Combination - Zone 2				2	UNCVX	UEAL4	\$43.53														
First 4-Wire Analog Voice Grade Loop/DS1 Interoffice Transport Combination - Zone 3				3	UNCVX	UEAL4	\$34.22														
Interoffice Transport - Dedicated - DS1 combination - Per Mile Per Month					UNCVX	1L5XX	\$0.2407														
Interoffice Transport - Dedicated - DS1 - Facility Termination Per Month					UNCVX	UTTF1	\$97.38														
Channelization - Channel System DS1 to DS0 combination Per Month					UNCVX	MO1	\$139.65														
Voice Grade COCI - DS1 to DS0 Channel System combination - per month					UNCVX	1D1VG	\$0.7676														
Additional 4-Wire Analog Voice Grade Loop in same DS1 Interoffice Transport Combination - Zone 1				1	UNCVX	UEAL4	\$38.65														
Additional 4-Wire Analog Voice Grade Loop in same DS1 Interoffice Transport Combination - Zone 2				2	UNCVX	UEAL4	\$43.53														
Additional 4-Wire Analog Voice Grade Loop in same DS1 Interoffice Transport Combination - Zone 3				3	UNCVX	UEAL4	\$34.22														
Nonrecurring Currently Combined Network Elements Switch -As-Is Change					UNCVX	UNCCC	\$11.19														
4-Wire VG Loop/Dedicated DS1 Interoffice Combination							\$11.19	\$11.19	\$13.91	\$161.68	\$13.91	\$13.91	\$10.89	\$33.63	\$27.49	\$19.88	\$11.85				
Nonrecurring Cost-new							\$625.52	\$342.39	\$161.68	\$49.26											
4-WIRE 56 Kbps EXTENDED DIGITAL LOOP WITH DEDICATED DS1 INTEROFFICE TRANSPORT (EEL)																					
First 4-Wire 56Kbps Digital Grade Loop/DS1 Interoffice Transport Combination - Zone 1				1	UNCDX	UDL56	\$35.92														
First 4-Wire 56Kbps Digital Grade Loop/DS1 Interoffice Transport Combination - Zone 2				2	UNCDX	UDL56	\$40.32														
First 4-Wire 56Kbps Digital Grade Loop/DS1 Interoffice Transport Combination - Zone 3				3	UNCDX	UDL56	\$37.4														
Interoffice Transport - Dedicated - DS1 combination - Per Mile Per Month					UNCVX	1L5XX	\$0.2407														
Interoffice Transport - Dedicated - DS1 - combination Facility Termination Per Month					UNCVX	UTTF1	\$97.38														

BELLSOUTH / ATT RATES
Unbundled Network Elements
KENTUCKY

CATEGORY	NOTES	UNBUNDLED NETWORK ELEMENT	Interim	Zone	BOS	USOC	Rate	RATES				OSS RATES								
								Nonrecurring	First	Advt	Discontinuation Fee	Nonrecurring	Advt	SOMEC	SOMAN	SOMAN	SOMAN	SOMAN	SOMAN	SOMAN
		Channelization - Channel System DS1 to DS0 combination Per Month			UNCLX	MC1	\$139.65													
		OCU-OP COCI (data) - DST to DS0 Channel System - Per month (24-64Kbs)			UNODX	1D1DD	\$1.63													
		Additional 4-Wire 56Kbps Digital Grade Loopin same DS1 Interoffice Transport Combination - Zone 1		1	UNODX	UDL56	\$35.92													
		Additional 4-Wire 56Kbps Digital Grade Loopin same DS1 Interoffice Transport Combination - Zone 2		2	UNODX	UDL56	\$40.32													
		Additional 4-Wire 56Kbps Digital Grade Loopin same DS1 Interoffice Transport Combination - Zone 3		3	UNODX	UDL56	\$37.4													
		OCU-OP COCI (data) - DST to DS0 Channel System - combination per month (2,4-64Kbs)			UNODX	1D1DD	\$1.63													
		Nonrecurring Currently Combined Network Elements Switch -As-Is Charge			UNCLX	UNCCC	\$11.19													
		4-Wire 56 Kbps Digital Loop/Dedicated DS1 Interoffice Combination Nonrecurring Cost-New					\$625.52													
		4-Wire 64 Kbps Extended Digital Loop with Dedicated DS1 Interoffice Combination					\$342.39													
		First 4-Wire 64Kbps Digital Grade Loop/DS1 Interoffice Transport Combination - Zone 1		1	UNODX	UDL64	\$35.92													
		First 4-Wire 64Kbps Digital Grade Loop/DS1 Interoffice Transport Combination - Zone 2		2	UNODX	UDL64	\$40.32													
		First 4-Wire 64Kbps Digital Grade Loop/DS1 Interoffice Transport Combination - Zone 3		3	UNODX	UDL64	\$37.4													
		Interoffice Transport - Dedicated - DS1 combination - Per Mile Per Month			UNCLX	1L5XX	\$0.2407													
		Interoffice Transport - Dedicated - DS1 combination - Facility Termination Per Month			UNCLX	1UTF1	\$97.38													
		Channelization - Channel System DS1 to DS0 combination Per Month			UNCLX	MC1	\$139.65													
		OCU-OP COCI (data) - DST to DS0 Channel System combination - per month (2,4-64Kbs)			UNODX	1D1DD	\$1.63													
		Additional 4-Wire 64Kbps Digital Grade Loopin same DS1 Interoffice Transport Combination - Zone 1		1	UNODX	UDL64	\$35.92													
		Additional 4-Wire 64Kbps Digital Grade Loopin same DS1 Interoffice Transport Combination - Zone 2		2	UNODX	UDL64	\$40.32													
		Additional 4-Wire 64Kbps Digital Grade Loopin same DS1 Interoffice Transport Combination - Zone 3		3	UNODX	UDL64	\$37.4													
		OCU-OP COCI (data) - DST to DS0 Channel System combination - per month (2,4-64Kbs)			UNODX	1D1DD	\$1.63													
		Nonrecurring Currently Combined Network Elements Switch -As-Is Charge			UNCLX	UNCCC	\$11.19													
		4-Wire 64 Kbps Digital Loop/Dedicated DS1 Interoffice Combination Nonrecurring Cost-New					\$625.52													
		4-Wire DS1 Digital Extended Loop with Dedicated DS1 Interoffice Transport					\$342.39													
		4-Wire DS1 Digital Loop in Combination with DS1 Interoffice Transport - Zone 1		1	UNCLX	USLXX	\$106.04													
		4-Wire DS1 Digital Loop in Combination with DS1 Interoffice Transport - Zone 2		2	UNCLX	USLXX	\$135.15													
		4-Wire DS1 Digital Loop in Combination with DS1 Interoffice Transport - Zone 3		3	UNCLX	USLXX	\$186.26													
		Interoffice Transport - Dedicated - DS1 combination - Per Mile Per Month			UNCLX	1L5XX	\$0.2407													
		Interoffice Transport - Dedicated - DS1 combination - Facility Termination Per Month			UNCLX	1UTF1	\$97.38													
		Nonrecurring Currently Combined Network Elements Switch -As-Is Charge			UNCLX	UNCCC	\$11.19													
		4-Wire DS1 Digital Loop with Dedicated DS1 Interoffice Transport Combination Nonrecurring Cost-New					\$644.46													
		4-Wire DS1 Digital Extended Loop with Dedicated DS1 Interoffice Transport					\$421.87													
		First DS1 Loop in DS3 Interoffice Transport Combination - Zone 1		1	UNCLX	USLXX	\$106.04													
		First DS1 Loop in DS3 Interoffice Transport Combination - Zone 2		2	UNCLX	USLXX	\$135.15													

BELLSOUTH / ATT RATES
Unbundled Network Elements
KENTUCKY

CATEGORY	NOTES	Interim	Zone	BGS	USGC	Rate	RATES				OSS RATES										
							First	ADDT	Discontinua Fees	ADDT	SOMEC	SOMAN	SOMAN	SOMAN	SOMAN	SOMAN	SOMAN	SOMAN			
	UNBUNDLED NETWORK ELEMENT																				
	First DS1 Loop in DS3 Interface Transport Combination - Zone 3		3	UNCGX	USLXX	\$186.28															
	Interface Transport - Dedicated - DS3 combination - Per Mile Per Month			UNCGX	1L5XX	\$4.67															
	Interface Transport - Dedicated - DS3 - Facility Termination per month			UNCGX	U1TF3	\$1,191.53															
	DS3 to DS1 Channel System combination per month			UNCGX	M03	\$194.82															
	DS3 Interface Unit (DS1 COCI) combination per month			UNCGX	UC1D1	\$14.53															
	Additional DS1 Loop in DS3 Interface Transport Combination - Zone 1		1	UNCGX	USLXX	\$106.04															
	Additional DS1 Loop in DS3 Interface Transport Combination - Zone 2		2	UNCGX	USLXX	\$135.15															
	Additional DS1 Loop in DS3 Interface Transport Combination - Zone 3		3	UNCGX	USLXX	\$186.28															
	DS3 Interface Unit (DS1 COCI) combination per month			UNCGX	UC1D1	\$14.53															
	Nonrecurring Currently Combined Network Elements Switch -As-Is Charge			UNCGX	UNCCC	\$11.19	\$11.19	\$13.91	\$13.91	\$10.89	\$33.63	\$27.49	\$19.88	\$11.85							
	4-Wire DS1 Digital Loop With Dedicated DS3 Interface Transport					\$1,192.60															
	Combination Nonrecurring Cost-new						\$565.27	\$178.70	\$74.26												
	2-WIRE VOICE GRADE EXTENDED LOOP/ 2 WIRE VOICE GRADE INTEROFFICE TRANSPORT (EEL)																				
	2-Wire/VG Loop used with 2-wire VG Interface Transport		1	UNCVX	UEAL2	\$17.78															
	Combination - Zone 1																				
	2-Wire/VG Loop used with 2-wire VG Interface Transport		2	UNCVX	UEAL2	\$23.96															
	Combination - Zone 2																				
	2-Wire/VG Loop used with 2-wire VG Interface Transport Combination		3	UNCVX	UEAL2	\$34.96															
	- Zone 3																				
	Interface Transport - Dedicated - 2-wire VG combination - Per Mile Per Month			UNCVX	1L5XX	\$0.0118															
	Interface Transport - Dedicated - 2-Wire Voice Grade combination - Facility Termination per month			UNCVX	U1TV2	\$29.51															
	Nonrecurring Currently Combined Network Elements Switch -As-Is Charge			UNCVX	UNCCC	\$11.19	\$11.19	\$13.91	\$13.91	\$10.89	\$33.63	\$27.49									
	2-Wire Loop/2-Wire Voice Grade Interface Transport					\$343.67															
	Combination Nonrecurring Cost new						\$178.90	\$157.48	\$46.34												
	4-WIRE VOICE GRADE EXTENDED LOOP/ 4 WIRE VOICE GRADE INTEROFFICE TRANSPORT (EEL)																				
	4-Wire VG Loop used with 4-wire VG Interface Transport Combination		1	UNCVX	UEAL4	\$38.65															
	- Zone 1																				
	4-Wire VG Loop used with 4-wire VG Interface Transport Combination		2	UNCVX	UEAL4	\$43.57															
	- Zone 2																				
	4-Wire/VG Loop used with 4-wire VG Interface Transport Combination		3	UNCVX	UEAL4	\$34.22															
	- Zone 3																				
	Interface Transport - Dedicated - 4-wire VG combination - Per Mile Per Month			UNCVX	1L5XX	\$0.0118															
	Interface Transport - Dedicated - 4-Wire Voice Grade combination - Facility Termination per month			UNCVX	U1TV4	\$26.22															
	Nonrecurring Currently Combined Network Elements Switch -As-Is Charge			UNCVX	UNCCC	\$11.19	\$11.19	\$13.91	\$13.91	\$10.89	\$33.63	\$27.49									
	4-Wire Voice Grade Loop/4-Wire Voice Grade Interface Transport					\$343.67															
	Combination Nonrecurring-new						\$178.90	\$157.48	\$46.34												
	DS3 DIGITAL EXTENDED LOOP WITH DEDICATED DS3 INTEROFFICE TRANSPORT (EEL)																				
	High Capacity Unbundled Local Loop - DS3 combination - Per Mile per month			UNCGX	1L5ND	\$11.53															
	High Capacity Unbundled Local Loop - DS3 combination - Facility Termination per month			UNCGX	UE9PX	\$379.72															
	Interface Transport - Dedicated - DS3 - Per Mile per month			UNCGX	1L5XX	\$5.1															
	Interface Transport - Dedicated - DS3 combination - Facility Termination per month			UNCGX	U1TF3	\$1,194.53															
	Nonrecurring Currently Combined Network Elements Switch -As-Is Charge			UNCGX	UNCCC	\$11.19	\$11.19	\$13.91	\$13.91	\$10.89	\$33.63	\$27.49									
	4-Wire Voice Grade Loop/4-Wire Voice Grade Interface Transport					\$343.67															
	Combination Nonrecurring Cost new						\$178.90	\$157.48	\$46.34												

BELLSOUTH / ATT RATES
Unbundled Network Elements
KENTUCKY

CATEGORY	NOTES	UNBUNDLED NETWORK ELEMENT	Intra- Zone	BOS	USOC	Rec	RATES				OSS RATES										
							First	Advt	Discontin Fees	Advt	SOMEC	SOMAN	SOMAN	Incremental Change - Manual Charge - Manual Electronic-1st	SOMAN	SOMAN	Incremental Change - Manual Order vs Electronic- Disc 1st	SOMAN	Incremental Change - Manual Order vs Electronic- Advt		
STSI DIGITAL EXTENDED LOOP WITH DEDICATED STS1 INTEROFFICE TRANSPORT (EEL)	High Capacity Unbundled Local Loop - STS1 combination - Per Mile per month			UNCSX	1LSND	\$11.53															
	High Capacity Unbundled Local Loop - STS1 combination - Facility Termination per month			UNCSX	UDLS1	\$379.72															
	Interface Transport - Dedicated - STS1 combination - Per Mile per month			UNCSX	1LSXX	\$5.1															
STSI Digital Loop/Dedicated STS1 Interface Transport	Interface Transport - Dedicated - STS1 combination - Facility Termination per month			UNCSX	UTFS	\$1,191.53															
	Nonrecurring Currently Combined Network Elements Switch -As-Is Charge			UNCSX	UNCCC	\$11.19	\$11.19	\$13.91	\$13.91	\$10.89											
	Combination-Nonrecurring Cost-new					\$999.50	\$508.20	\$189.53	\$89.31												
2-WIRE ISDN EXTENDED LOOP WITH DS1 INTEROFFICE TRANSPORT (EEL)	First 2-Wire ISDN Loop/DS1 Interface Combination Transport - Zone 1			UNCNX	UHL2X	\$25.73															
	First 2-Wire ISDN Loop/DS1 Interface Combination Transport - Zone 2			UNCNX	UHL2X	\$34.83															
	First 2-Wire ISDN Loop/DS1 Interface Combination Transport - Zone 3			UNCNX	UHL2X	\$45.46															
Interface Transport - Dedicated - DS1 combination - Per Mile Termination per month	Interface Transport - Dedicated - DS1 combination - Facility Termination per month			UNCNX	UHTF1	\$97.38															
	Channelization - Channel System DS1 to DSO combination - per month			UNCNX	M01	\$139.65															
	2-wire ISDN COC (BRTE) - DS1 to DSO Channel System combination - per month			UNCNX	UC1CA	\$3.5															
Additional 2-wire ISDN Loop in same DS1 Interface Transport	Combination - Zone 1			UNCNX	UHL2X	\$25.73															
	Combination - Zone 2			UNCNX	UHL2X	\$34.83															
	Combination - Zone 3			UNCNX	UHL2X	\$45.46															
Additional 2-wire ISDN Loop in same DS1 Interface Transport	Combination - Zone 1			UNCNX	UHL2X	\$25.73															
	Combination - Zone 2			UNCNX	UHL2X	\$34.83															
	Combination - Zone 3			UNCNX	UHL2X	\$45.46															
2-wire ISDN COC (BRTE) - DS1 to DSO Channel System combination - per month	Combination- per month			UNCNX	UC1CA	\$3.5															
	Nonrecurring Currently Combined Network Elements Switch -As-Is Charge			UNCNX	UNCCC	\$11.19	\$11.19	\$13.91	\$13.91	\$10.89											
	Nonrecurring Cost-new					\$625.62	\$342.39	\$161.68	\$49.26												
4-WIRE DS1 DIGITAL EXTENDED LOOP WITH DEDICATED STS-1 INTEROFFICE TRANSPORT (EEL)	First DS1 Loop in STS1 Interface Transport Combination - Zone 1			UNCI1X	USLXX	\$106.04															
	First DS1 Loop in STS1 Interface Transport Combination - Zone 2			UNCI1X	USLXX	\$135.15															
	First DS1 Loop in STS1 Interface Transport Combination - Zone 3			UNCI1X	USLXX	\$186.25															
Interface Transport - Dedicated - STS1 combination - Per Mile Per Month	Interface Transport - Dedicated - STS1 combination - Facility Termination			UNCSX	1LSXX	\$5.1															
	STS1 to DS1 Channel System combination per month			UNCSX	UTFS	\$1,165.53															
	DS3 Interface Unit (DS1 COC) combination per month			UNCSX	M03	\$194.82															
Additional DS1 Loop in STS1 Interface Transport Combination - Zone 1	Additional DS1 Loop in STS1 Interface Transport Combination - Zone 1			UNCI1X	USLXX	\$106.04															
	Additional DS1 Loop in STS1 Interface Transport Combination - Zone 2			UNCI1X	USLXX	\$135.15															
	Additional DS1 Loop in STS1 Interface Transport Combination - Zone 3			UNCI1X	USLXX	\$186.25															
Additional DS1 Loop in STS1 Interface Transport Combination - Zone 1	Additional DS1 Loop in STS1 Interface Transport Combination - Zone 1			UNCI1X	USLXX	\$106.04															
	Additional DS1 Loop in STS1 Interface Transport Combination - Zone 2			UNCI1X	USLXX	\$135.15															
	Additional DS1 Loop in STS1 Interface Transport Combination - Zone 3			UNCI1X	USLXX	\$186.25															
DS3 Interface Unit (DS1 COC) combination per month	Nonrecurring Currently Combined Network Elements Switch -As-Is Charge			UNCI1X	UC1D1	\$14.53															
	Nonrecurring Cost-new					\$11.19	\$11.19	\$13.91	\$13.91	\$10.89											
	Combination-Nonrecurring Cost-new					\$1,192.60	\$565.27	\$178.70	\$74.26												
4-WIRE 56 Kbps DIGITAL EXTENDED LOOP WITH 56 Kbps INTEROFFICE TRANSPORT (EEL)	4-wire 56 kbps Loop/4-wire 56 kbps Interface Transport Combination - Zone 1			UNCDX	UDLS6	\$35.92															

BELLSOUTH / ATT RATES
Unbundled Network Elements
KENTUCKY

CATEGORY	NOTES	UNBUNDLED NETWORK ELEMENT	Intrm	Zone	BOS	USOC	Rec	RATES				OSS RATES								
								First	Advt	Discontin Fees	Advt	SOMEC	SOMAN	SOMAN	SOMAN	SOMAN	SOMAN	SOMAN		
		4-wire 56 kbps Loop/4-wire 56 kbps Interoffice Transport Combination - Zone 2		2	UNCDX	UDL66	\$40.32													
		4-wire 56 kbps Loop/4-wire 56 kbps Interoffice Transport Combination - Zone 3		3	UNCDX	UDL66	\$37.99													
		Interoffice Transport - Dedicated - 4-wire 56 kbps combination - Per Mile			UNCDX	1L5XX	\$0.0118													
		Interoffice Transport - Dedicated - 4-wire 56 kbps combination - Facility Termination			UNCDX	U1TD5	\$21.26													
		Nonrecurring Currently Combined Network Elements Switch -As-Is Charge			UNCDX	UNCCG	\$11.19		\$11.19	\$13.91	\$13.91	\$10.89	\$33.63	\$27.49						
		4-wire 56 kbps Digital Loop/DS0 Interoffice Transport Combinations Nonrecurring Cost-New					\$343.67		\$178.90	\$157.48	\$46.34									
		4 WIRE 64 KBPS DIGITAL EXTENDED LOOP WITH 64 KBPS INTEROFFICE TRANSPORT (EEL)																		
		4-wire 64 kbps Loop/4-wire 64 kbps Interoffice Transport Combination - Zone 1		1	UNCDX	UDL64	\$35.92													
		4-wire 64 kbps Loop/4-wire 64 kbps Interoffice Transport Combination - Zone 2		2	UNCDX	UDL64	\$40.32													
		4-wire 64 kbps Loop/4-wire 64 kbps Interoffice Transport Combination - Zone 3		3	UNCDX	UDL64	\$37.9													
		Interoffice Transport - Dedicated - 4-wire 64 kbps combination - Per Mile			UNCDX	1L5XX	\$0.0118													
		Interoffice Transport - Dedicated - 4-wire 64 kbps combination - Facility Termination			UNCDX	U1TD6	\$21.26													
		Nonrecurring Currently Combined Network Elements Switch -As-Is Charge			UNCDX	UNCCG	\$11.19		\$11.19	\$13.91	\$13.91	\$10.89	\$33.63	\$27.49						
		4-wire 64 KBPS Digital Loop/DS0 Interoffice Transport Combinations Nonrecurring Cost-New					\$343.67		\$178.90	\$157.48	\$46.34									
		ADDITIONAL NETWORK ELEMENTS																		
		When used as a part of a currently combined facility, the non-recurring charges do not apply, but a Switch As Is charge does apply.																		
		When used as ordinarily combined network elements in Georgia, the non-recurring charges apply and the Switch As Is Charge does not.																		
		Nonrecurring Currently Combined Network Elements - "Switch As Is" Charge (One applies to each combination)																		
		2x4-wire V/G Interoffice Channel used in a COMBINATION - "Switch As Is" Conversion Charge			UNCVX	UNCCG	\$11.19		\$11.19	\$13.91	\$13.91	\$10.89	\$33.63	\$27.49	\$19.88	\$11.85				
		56/64 kbps Interoffice Channel used in a COMBINATION - "Switch As Is" Conversion Charge			UNCDX	UNCCG	\$11.19		\$11.19	\$13.91	\$13.91	\$10.89	\$33.63	\$27.49	\$19.88	\$11.85				
		DS1 Interoffice Channel used in a COMBINATION - "Switch As Is" Conversion Charge			UNCVX	UNCCG	\$11.19		\$11.19	\$13.91	\$13.91	\$10.89	\$33.63	\$27.49	\$19.88	\$11.85				
		DS3 Interoffice Channel used in a COMBINATION - "Switch As Is" Conversion Charge			UNCVX	UNCCG	\$11.19		\$11.19	\$13.91	\$13.91	\$10.89	\$33.63	\$27.49	\$19.88	\$11.85				
		STS1 Interoffice or Local Loop used in a COMBINATION - "Switch As Is" Conversion Charge			UNGSX	UNCCG	\$11.19		\$11.19	\$13.91	\$13.91	\$10.89	\$33.63	\$27.49	\$19.88	\$11.85				
		NOTE: Local Channel - Dedicated Transport - minimum billing period - Below DS3-one month, DS3 and above-four months																		
		Local Channel - Dedicated - 2-Wire Voice Grade per month			UNCVX	ULDVZ	\$18.18													
		Local Channel - Dedicated - 4-Wire Voice Grade per month			UNCVX	ULDV4	\$20.12													
		Local Channel - Dedicated - DS1 per Month Zone 1		1	UNCVX	ULD71	\$44.63													
		Local Channel - Dedicated - DS1 per Month Zone 2		2	UNCVX	ULD71	\$40.74													
		Local Channel - Dedicated - DS1 - Per Month Zone 3		3	UNCVX	ULD71	\$42.95													
		Local Channel - Dedicated - DS3 - Per Mile per month			UNCVX	1L5NC	\$8.98													
		Local Channel - Dedicated - DS3 - Facility Termination per month			UNCVX	ULD73	\$683.57													
		Local Channel - Dedicated - STS-1 - Per Mile per month			UNCVX	1L5NC	\$8.98													
		Local Channel - Dedicated - STS-1 - Facility Termination per month			UNCVX	ULD75	\$550.34													

BELLSOUTH/ ATT RATES
Unbundled Network Elements
KENTUCKY

CATEGORY	NOTES	UNBUNDLED NETWORK ELEMENT	Interim	Zone	BOS	USOC	Reg	RATES				OSS RATES					
								Nonrecurring		Disconnect		Svc Order Submitted per USR	Svc Order Submitted Monthly per USR	Incremental Charge - Manual Order vs. Electronic-311	Incremental Charge - Manual Order vs. Electronic-5400	Incremental Charge - Manual Svc Order vs. Electronic-311	Incremental Charge - Manual Svc Order vs. Electronic-Disc Adrt
								First	Adrt	First	Adrt	SOMEC	SOMAN	SOMAN	SOMAN	SOMAN	SOMAN
UNBUNDLED LOCAL EXCHANGE SWITCHING(PORTS)																	
	Exchange Ports																
	NOTE: Although the Port Rate includes all available features in GA & TN, the desired features will need to be ordered using retail USOCs																
	2-WIRE VOICE GRADE LINE PORT RATES (RES)																
	Exchange Ports - 2-Wire Analog Line Port - Res.																
	Exchange Ports - 2-Wire Analog Line Port with Caller ID - Res.																
	Exchange Ports - 2-Wire Analog Line Port outgoing only - Res.																
	Exchange Ports - 2-Wire V/G unbundled KY extended local dialing party Port with Caller ID - Res.																
	Exchange Ports - 2-Wire V/G unbundled res, low usage line port with Caller ID (LUM)																
	Subsequent Activty																
	FEATURES																
	All Available Vertical Features																
	2-WIRE VOICE GRADE LINE PORT RATES (BUS)																
	Exchange Ports - 2-Wire Analog Line Port without Caller ID - Bus																
	Exchange Ports - 2-Wire V/G unbundled Line Port with unbundled port with Caller+484 ID - Bus.																
	Exchange Ports - 2-Wire Analog Line Port outgoing only - Bus.																
	Exchange Ports - 2-Wire V/G unbundled KY extended local dialing party Port with Caller ID - Bus.																
	Exchange Ports - 2-Wire V/G unbundled incoming only port with Caller ID - Bus																
	Subsequent Activty																
	FEATURES																
	All Available Vertical Features																
	EXCHANGE PORT RATES (DID & PBX)																
	All Available Vertical Features																
	Exchange Ports - 2-Wire DID Port																
	Exchange Ports - DDITS Port - 4-Wire DSI Port with DID capability																
	Exchange Ports - 2-Wire ISDN Port (See Notes below.)																
	All Features Offered																

It is the intent of the Parties that where applicable state commissions have approved rates for network elements and other services set forth in this Agreement as of the date hereof, such rates have been included in this exhibit, unless otherwise agreed to by the Parties. Geographically Deaveraged UNE Zones and applicable rates have been established for certain services, as shown in this Agreement. Where Geographically Deaveraged UNE Zones and applicable rates are established, Statewide rates are considered "uniform". Bellsouth is in the process of enhancing its billing systems in order to accommodate this Geographically Deaveraged UNE Zone Rate Structure. Until these enhancements are accomplished, estimated to be mid 2001, the UNE Zone 1 rate will be billed for all services residing in Zones 1, 2, 3 or 4, i.e., Rates for services residing in UNE Zones 2, 3 and UNE Zone 4, where applicable, will not be billed. Once billing enhancements are complete, all applicable UNE Zone rates reflected in this Agreement will be billed. Reference Internet Website http://www.interconnection.bellsouth.com/discome_chef/docs/interconnectiondeavuzrs.pdf to view Geographically Deaveraged UNE Zone Designations by Central Office.

BELLSOUTH / ATT RATES
Unbundled Network Elements
KENTUCKY

CATEGORY	NOTES	UNBUNDLED NETWORK ELEMENT	Interim	Zone	BOS	USOC	Req	RATES		OSS RATES									
								First	ADDT	First	ADDT	SOMEC	SOMAN	SOMAN	SOMAN	SOMAN	SOMAN		
								Nonrecurring		Disconnect				See Order Submitted per USR	See Order Submitted per USR	Incremental Charge - Manual Svc Order vs. Electronic-1st	Incremental Charge - Manual Svc Order vs. Electronic-ADDT	Incremental Charge - Manual Svc Order vs. Electronic-1st	Incremental Charge - Manual Svc Order vs. Electronic-ADDT
	NOTE: Access to B Channel or D Channel/Packet capabilities will be available only through BFR/New Business Request Process. Rates for the packet capabilities will be determined via the Bona Fide Request/New Business Request Process.	Exchange Ports - 2-Wire ISDN Port - Channel Profiles			UEPTX UEPXSX	UTUMA	\$0.0	\$0.0	\$203.18	\$157.84	\$39.98								
		Exchange Ports - 4-Wire ISDN DSI Port			UEPXE	UEPXA	\$113.21	\$407.77	\$0.0										
		2-Wire VG Unbundled 2-Way PBX Trunk - Res			UEPSE	UEPRD	\$2.61	\$36.47	\$36.47	\$36.47			\$10.89	\$22.00					
		2-Wire VG Line Side Unbundled 2-Way PBX Trunk - Bus			UEPSP	UEPPC	\$2.61	\$36.47	\$36.47	\$36.47			\$10.89	\$22.00					
		2-Wire VG Line Side Unbundled Outward PBX Trunk - Bus			UEPSP	UEPPO	\$2.61	\$36.47	\$36.47	\$36.47			\$10.89	\$22.00					
		2-Wire VG Line Side Unbundled Incoming PBX Trunk - Bus			UEPSP	UEPPI	\$2.61	\$36.47	\$36.47	\$36.47			\$10.89	\$22.00					
		2-Wire Analog Long Distance Terminal PBX Trunk - Bus			UEPSP	UEPLD	\$2.61	\$36.47	\$36.47	\$36.47			\$10.89	\$22.00					
		2-Wire Analog TN 2-Way Calling Plan PBX Trunk - Bus			UEPSP	UEPT2	\$2.61	\$36.47	\$36.47	\$36.47			\$10.89	\$22.00					
		2-Wire TN Outward Calling Plan PBX Trunk - Bus			UEPSP	UEPTO	\$2.61	\$36.47	\$36.47	\$36.47			\$10.89	\$22.00					
		2-Wire Voice Unbundled PBX LD Terminal Ports			UEPSP	UEPLD	\$2.61	\$36.47	\$36.47	\$36.47			\$10.89	\$22.00					
		2-Wire Voice Unbundled 2-Way PBX Usaga Port			UEPSP	UEPXA	\$2.61	\$36.47	\$36.47	\$36.47			\$10.89	\$22.00					
		2-Wire Voice Unbundled PBX Toll Terminal/Hotel Ports			UEPSP	UEPXA	\$2.61	\$36.47	\$36.47	\$36.47			\$10.89	\$22.00					
		2-Wire Voice Unbundled PBX LD DDD Terminal/Hotel Ports			UEPSP	UEPXC	\$2.61	\$36.47	\$36.47	\$36.47			\$10.89	\$22.00					
		2-Wire Voice Unbundled PBX LD Terminal Switchboard Port			UEPSP	UEPXC	\$2.61	\$36.47	\$36.47	\$36.47			\$10.89	\$22.00					
		2-Wire Voice Unbundled PBX LD Terminal Switchboard IDD Capable Port			UEPSP	UEPXD	\$2.61	\$36.47	\$36.47	\$36.47			\$10.89	\$22.00					
		2-Wire Voice Unbundled 2-Way PBX Kentucky Room Area Calling Port Without LUD			UEPSP	UEPXE	\$2.61	\$36.47	\$36.47	\$36.47			\$10.89	\$22.00					
		2-Wire Voice Unbundled PBX Kentucky LUD Area Calling Port			UEPSP	UEPXF	\$2.61	\$36.47	\$36.47	\$36.47			\$10.89	\$22.00					
		2-Wire Voice Unbundled PBX Kentucky Premium Calling Port			UEPSP	UEPXF	\$2.61	\$36.47	\$36.47	\$36.47			\$10.89	\$22.00					
		2-Wire Voice Unbundled 2-Way PBX Kentucky Area Calling Port Without LUD			UEPSP	UEPZH	\$2.61	\$36.47	\$36.47	\$36.47			\$10.89	\$22.00					
		2-Wire Voice Unbundled 2-Way PBX Hotel/Hospital Economy Administrative Calling Port			UEPSP	UEPYU	\$2.61	\$36.47	\$36.47	\$36.47			\$10.89	\$22.00					
	2-Wire Voice Unbundled 2-Way PBX Hotel/Hospital Economy Room Calling Port			UEPSP	UEPYL	\$2.61	\$36.47	\$36.47	\$36.47			\$10.89	\$22.00						
	2-Wire Voice Unbundled 2-Way PBX Hotel/Hospital Economy Room Calling Port			UEPSP	UEPYM	\$2.61	\$36.47	\$36.47	\$36.47			\$10.89	\$22.00						
	2-Wire Voice Unbundled 1-Way Outgoing PBX Hotel/Hospital Discount Room Calling Port			UEPSP	UEPXO	\$2.61	\$36.47	\$36.47	\$36.47			\$10.89	\$22.00						
	2-Wire Voice Unbundled 1-Way Outgoing PBX Measured Port			UEPSP	UEPXS	\$2.61	\$36.47	\$36.47	\$36.47			\$10.89	\$22.00						
	Subsequent Activity			UEPSP	USASC	\$0.0	\$0.0	\$0.0	\$0.0			\$10.89	\$22.00						
	FEATURES				UEPSP UEPSE	UEPXF	\$3.99	\$0.0	\$0.0			\$10.89	\$22.00						
	EXCHANGE PORT RATES (COIN)						\$3.04	\$40.71	\$40.71			\$10.89	\$22.00						
	Exchange Ports - Coin Port																		
	Local Switching Features offered with Port																		
	NOTE: Transmission/usage charges associated with POT S circuit switched usage will also apply to circuit switched voice and/or circuit switched data transmission by B-Channels associated with 2-wire ISDN ports.																		
	NOTE: Access to B Channel or D Channel/Packet capabilities will be available only through BFR/New Business Request Process. Rates for the packet capabilities will be determined via the Bona Fide Request/New Business Request Process.																		
	Exchange port - 4-wire ISDN trunk port - all available features included				UEPXE		\$275.48	\$181.27	\$116.42			\$10.89	\$29.24				\$3.94	\$3.94	
	UNBUNDLED LOCAL SWITCHING PORT USAGE																		
	End Office Switching (Port Usage)							\$0.002582											
	End Office Switching Function, Per MOU																		

BELLSOUTH / ATT RATES
Unbundled Network Elements
KENTUCKY

Attachment 2
Exhibit A(2)
Rates - Page 3

CATEGORY	NOTES	UNBUNDLED NETWORK ELEMENT	Interm	Zone	BCS	USOC	Reg	RATES								OSS RATES							
								Nonrecuring				Disconnect				SOMEC	SOMAN	SOMAN	SOMAN	SOMAN	SOMAN	SOMAN	
								First	Add'l	First	Add'l	First	Add'l	First	Add'l								
	Tandem Switching (Port Usage) (Local or Access Tandem)						\$0.007096																
	Tandem Switching Function Per MOU																						
	Common Transport						\$0.000049																
	Common Transport - Per Mile, Per MOU																						
	Common Transport - Facilities Termination Per MOU						\$0.000426																
UNBUNDLED PORT/LOOP COMBINATIONS - COST BASED RATES																							
Cost Based Rates are applied where BellSouth is required by FCC and/or State Commission rule to provide Unbundled Local Switching or Switch Ports																							
Features shall apply to the Unbundled Port/Loop Combination - Cost Based Rate section in the same manner as they are applied to the Stand-Alone Unbundled Port section of this Rate Exhibit.																							
End Office and Tandem Switching Usage and Common Transport Usage rates in the Port section of this rate exhibit shall apply to all combinations of loop/port network elements except for UNE Coin Port/Loop Combinations.																							
For Georgia, the recurring UNE Port and Loop charges listed apply to Currently Combined and Not Currently Combined Combos and the first and additional Port nonrecurring charges apply to Not Currently Combined Combos. For Currently Combined Combos in GA and all other states, the nonrecurring charges shall be those identified in the Nonrecurring - Currently Combined sections:																							
2-WIRE VOICE GRADE LOOP WITH 2-WIRE LINE PORT (RES)																							
UNE Port/Loop Combination Rates																							
2-Wire VG Loop/Port Combo - Zone 1				1			\$16.15																
2-Wire VG Loop/Port Combo - Zone 2				2			\$22.34																
2-Wire VG Loop/Port Combo - Zone 3				3			\$30.88																
UNE Loop Rates																							
2-Wire Voice Grade Loop (SL1) - Zone 1				1		UEPRX	UEPLX	\$13.54															
2-Wire Voice Grade Loop (SL1) - Zone 2				2		UEPRX	UEPLX	\$19.73															
2-Wire Voice Grade Loop (SL1) - Zone 3				3		UEPRX	UEPLX	\$28.27															
2-Wire Voice Grade Line Port Rates (Res)																							
2-Wire voice unbundled port - residence						UEPRX	UEPRL	\$2.61					\$10.89				\$22.00						
2-Wire voice unbundled port with Caller ID - res						UEPRX	UEPRC	\$2.61					\$10.89				\$22.00						
2-Wire voice unbundled port outgoing only - res						UEPRX	UEPRO	\$2.61					\$10.89				\$22.00						
2-Wire voice Grade unbundled Kentucky extended local dialing party port with Caller ID - res						UEPRX	UEPRM	\$2.61					\$10.89				\$22.00						
2-Wire voice unbundles res, low usage line port with Caller ID (LUM)						UEPRX	UEPAP	\$2.61					\$10.89				\$22.00						
FEATURES																							
All Features Offered						UEPRX	UEPVF	\$3.39		\$0.0		\$0.0			\$10.89		\$22.00		\$22.00				
LOCAL NUMBER PORTABILITY																							
Local Number Portability (1 per port)						UEPRX	LNPX	\$0.35															

BELLSOUTH/ ATT RATES
Unbundled Network Elements
KENTUCKY

CATEGORY	NOTES	UNBUNDLED NETWORK ELEMENT	Interim	Zone	BOS	USOC	Res	RATES				OSS RATES				
								Nonrecurring	First	Add'l	Disconnect	First	Add'l	SOMEC	SOMAN	SOMAN
NONRECURRING CHARGES (NRCS) - CURRENTLY COMBINED	2-Wire Voice Grade Loop / Line Port Combination - Conversion - Switch-axis				UEPRX	USAC2		\$10.00	\$10.00				\$10.89	\$22.00	\$22.00	
	2-Wire Voice Grade Loop / Line Port Combination - Conversion - Switch with change				UEPRX	USACC		\$10.00	\$10.00				\$10.89	\$22.00	\$22.00	
								\$21.21	\$15.43							
ADDITIONAL NRCS	2-Wire Voice Grade Loop/Line Port Combination - Subsequent Activity				UEPRX	USAS2	\$0.0	\$0.0	\$0.0				\$10.89	\$19.99		
	2-WIRE VOICE GRADE LOOP WITH 2-WIRE LINE PORT (BUS)	UNE Port/Loop Combination Rates														
		2-Wire VG Loop/Port Combo - Zone 1		1				\$16.15								
2-Wire VG Loop/Port Combo - Zone 2			2				\$22.34									
	2-Wire VG Loop/Port Combo - Zone 3		3				\$30.88									
UNE Loop Rates	2-Wire Voice Grade Loop (SL1) - Zone 1			1	UEPBX	UEPLX	\$13.54									
	2-Wire Voice Grade Loop (SL1) - Zone 2			2	UEPBX	UEPLX	\$19.73									
	2-Wire Voice Grade Loop (SL1) - Zone 3			3	UEPBX	UEPLX	\$28.27									
2-Wire Voice Grade Line Port (Bus)	2-Wire voice unbundled port without Caller ID - bus				UEPBX	UEPBL	\$2.61						\$10.89	\$22.00	\$22.00	
	2-Wire voice unbundled port with Caller + E984 ID - bus				UEPBX	UEPBC	\$2.61						\$10.89	\$22.00	\$22.00	
	2-Wire voice unbundled port outgoing only - bus				UEPBX	UEPBO	\$2.61						\$10.89	\$22.00	\$22.00	
LOCAL NUMBER PORTABILITY	2-Wire voice Grade unbundled Kentucky extended local dialing party port with Caller ID - bus				UEPBX	UEPBM	\$2.61						\$10.89	\$22.00	\$22.00	
	2-Wire voice unbundled incoming only port with Caller ID - Bus				UEPBX	UEPBI	\$2.61						\$10.89	\$22.00	\$22.00	
	Local Number Portability (1 per port)				UEPBX	LNFCX	\$0.35									
FEATURES	All Features Offered				UEPBX	UEPVF	\$3.39	\$0.0	\$0.0				\$10.89	\$22.00	\$22.00	
NONRECURRING CHARGES (NRCS) - CURRENTLY COMBINED	2-Wire Voice Grade Loop / Line Port Combination - Conversion - Switch-axis				UEPBX	USAC2		\$10.00	\$10.00				\$10.89	\$22.00	\$22.00	
	2-Wire Voice Grade Loop / Line Port Combination - Conversion - Switch with change				UEPBX	USACC		\$10.00	\$10.00				\$10.89	\$22.00	\$22.00	
								\$21.21	\$15.43							
ADDITIONAL NRCS	2-Wire Voice Grade Loop/line Port Combination - Subsequent Activity				UEPBX	USAS2							\$10.89	\$22.00	\$22.00	
	2-WIRE VOICE GRADE LOOP WITH 2-WIRE LINE PORT (RES - PBX)	UNE Port/Loop Combination Rates														
		2-Wire VG Loop/Port Combo - Zone 1		1				\$16.15								
2-Wire VG Loop/Port Combo - Zone 2			2				\$22.34									
	2-Wire VG Loop/Port Combo - Zone 3		3				\$30.88									
UNE Loop Rates	2-Wire Voice Grade Loop (SL 1) - Zone 1			1	UEPRG	UEPLX	\$13.54									
	2-Wire Voice Grade Loop (SL 1) - Zone 2			2	UEPRG	UEPLX	\$19.73									
	2-Wire Voice Grade Loop (SL 1) - Zone 3			3	UEPRG	UEPLX	\$28.27									

BELLSOUTH / ATT RATES
Unbundled Network Elements
KENTUCKY

CATEGORY	NOTES	UNBUNDLED NETWORK ELEMENT	Intrm	Zone	BCS	USOC	Res	RATES				OSS RATES									
								Nonrecurring	Disconnect	SOMEC	SOMAN	SOMAN	SOMAN	SOMAN	SOMAN						
2-Wire Voice Grade Line Port Rates (RES - PBX)	2-Wire V/S Unbundled Combination 2-Way PBX Trunk Port - Res				UEPRG	UEPRD	\$2.61														
LOCAL NUMBER PORTABILITY	Local Number Portability (1 per port)				UEPRG	LNPCL	\$3.5														
FEATURES	All Features Offered				UEPRG	UEPVF	\$3.39														
NONRECURRING CHARGES (NRCS) - CURRENTLY COMBINED	2-Wire Voice Grade Loop Line Port Combination (PBX) - Conversion - Switch-As-Is				UEPRG	USAC2	\$10.00														
NONRECURRING CHARGES (NRCS) - NEW	2-Wire Voice Grade Loop Line Port Combination (PBX) - Conversion - Switch with Change				UEPRG	USACC	\$10.00														
ADDITIONAL NRCS	2-Wire Voice Grade Loop Line Port Combination (PBX) - Subsequent Activity - Change/Rearrange Multiline Hunt Group				UEPRG	USAS2	\$0.0														
2-WIRE VOICE GRADE LOOP WITH 2-WIRE LINE PORT (BUS - PBX)																					
UNE Port/Loop Combination Rates	2-Wire VG Loop/Port Combo - Zone 1																				
UNE Loop Rates	2-Wire Voice Grade Loop (SL 1) - Zone 1																				
2-Wire Voice Grade Line Port Rates (BUS - PBX)	Line Side Unbundled Combination 2-Way PBX Trunk Port - Bus																				

BELLSOUTH / ATT RATES
Unbundled Network Elements
KENTUCKY

CATEGORY	NOTES	UNBUNDLED NETWORK ELEMENT	Interim	Zone	BOS	USOC	Rec	RATES				OSS RATES								
								Nonrecurring	First	Add'l	Disconnect	First	Add'l	SOMEC	SOMAN	SOMAN	SOMAN	SOMAN	SOMAN	
LOCAL NUMBER PORTABILITY	Local Number Portability (1 per port)				UEPPX	LNPFP	\$3.15													
FEATURES	All Features Offered				UEPPX	UEPVF	\$3.39	\$0.0	\$0.0											
NONRECURRING CHARGES (NRCS) - CURRENTLY COMBINED																				
	2-Wire Voice Grade Loop/ Line Port Combination (PBX) - Conversion - Switch-Axis				UEPPX	USAC2	\$10.00	\$10.00	\$10.00											
	2-Wire Voice Grade Loop/ Line Port Combination (PBX) - Conversion - Switch with Change				UEPPX	USAC	\$10.00	\$10.00	\$10.00											
NONRECURRING CHARGES (NRCS) - NEW																				
ADDITIONAL NRCS																				
	2-Wire Voice Grade Loop/ Line Port Combination (PBX) - Subsequent Activity				UEPPX	USAS2	\$0.0	\$0.0	\$0.0											
	PBX Subsequent Activity - Change/Rearrange Multiline Hunt Group							\$14.64	\$14.64											
2-WIRE VOICE GRADE LOOP WITH 2-WIRE ANALOG LINE COIN PORT																				
UNE Port/Loop Combination Rates																				
	2-Wire VG Coin Port/Loop Combo - Zone 1							\$16.15												
	2-Wire VG Coin Port/Loop Combo - Zone 2							\$22.64												
	2-Wire VG Coin Port/Loop Combo - Zone 3							\$31.09												
UNE Loop Rates																				
	2-Wire Voice Grade Loop (SL1) - Zone 1				UEPCO	UEPLX	\$13.54													
	2-Wire Voice Grade Loop (SL1) - Zone 2				UEPCO	UEPLX	\$19.73													
	2-Wire Voice Grade Loop (SL1) - Zone 3				UEPCO	UEPLX	\$29.27													
2-Wire Voice Grade Line Ports (COIN)																				
	2-Wire Coin 2-Way without Operator Screening and without Blocking (AL, KY, LA, MS)				UEPCO	UEPRE	\$2.91													
	2-Wire Coin 2-Way with Operator Screening (AL, KY)				UEPCO	UEPRE	\$2.91													
	2-Wire Coin 2-Way with Operator Screening and Blocking - 011, 900/976, 1+DDD (AL, KY, LA, MS)				UEPCO	UEBRA	\$2.91													
	2-Wire Coin 2-Way with Operator Screening and 011 Blocking (KY)				UEPCO	UEBKA	\$2.91													
	2-Wire Coin 2-Way with Operator Screening & Blocking - 900/976, 1+DDD, 011+, & Local (AL, KY, LA, MS)				UEPCO	UEPCD	\$2.91													
	2-Wire Coin 2-Way without Blocking and without Operator Screening (KY, LA, MS)				UEPCO	UEPRN	\$2.91													
	2-Wire Coin 2-Way with Operator Screening and 011 Blocking (GA, KI, MS)				UEPCO	UEPRJ	\$2.91													
	2-Wire Coin 2-Way with Operator Screening and Blocking - 011, 900/976, 1+DDD (AL, KY, LA, MS)				UEPCO	UEPRH	\$2.91													
	2-Wire Coin 2-Way with Operator Screening & Blocking - 900/976, 1+DDD, 011+, and Local (AL, KY, LA, MS)				UEPCO	UEPCN	\$2.91													
	2-Wire 2-Way Smartline with 900/976 (all states except LA)				UEPCO	UEPCK	\$2.91													
	2-Wire Coin 2-Way Smartline with 900/976 (all states except LA)				UEPCO	UEPCR	\$2.91													
ADDITIONAL UNE COIN PORT/LOOP (RC)																				
	UNE Coin Port/Loop Combo Usage (Flat Rate)				UEPCO	URECU	\$2.57	\$0.0	\$0.0											
LOCAL NUMBER PORTABILITY	Local Number Portability (1 per port)				UEPCO	LNPFX	\$0.35													
NONRECURRING CHARGES - CURRENTLY COMBINED																				

BELLSOUTH/ ATT RATES
Unbundled Network Elements
KENTUCKY

CATEGORY	NOTES	UNBUNDLED NETWORK ELEMENT	Interm	Zone	BOS	USOC	Res	RATES				OSS RATES						
								Nonrecurring		Nonrecurring		SOMEC	SOMAN	SOMAN	SOMAN	SOMAN	SOMAN	
								First	Addl	First	Addl							
	2-Wire Voice Grade Loop / Line Port Combination - Conversion - Switch-asis				UEPCO	USAC2		\$10.00	\$10.00									
	2-Wire Voice Grade Loop / Line Port Combination - Conversion - Switch with change				UEPCO	USACC		\$10.00	\$10.00									
	NONRECURRING CHARGES (NRCS) - NEW							\$21.21	\$15.43									
	ADDITIONAL NRCS																	
	2-Wire Voice Grade Loop/Line Port Combination - Subsequent Activity				UEPCO	USAS2		\$0.0	\$0.0									
	2-WIRE VOICE GRADE LOOP - BUS ONLY - WITH 2-WIRE DID TRUNK PORT																	
	UNE Port/Loop Combination Rates																	
	2-Wire VG Loop/2-Wire DID Trunk Port Combo - UNE Zone 1			1				\$28.72										
	2-Wire VG Loop/2-Wire DID Trunk Port Combo - UNE Zone 2			2				\$34.90										
	2-Wire VG Loop/2-Wire DID Trunk Port Combo - UNE Zone 3			3				\$45.90										
	UNE Loop Rates																	
	2-Wire Analog Voice Grade Loop - (SL2) - UNE Zone 1			1	UEPPX	UEGD1		\$17.78	\$210.31	\$195.35	\$105.49	\$20.43	\$22.00					
	2-Wire Analog Voice Grade Loop - (SL2) - UNE Zone 2			2	UEPPX	UEGD1		\$23.96	\$210.31	\$195.35	\$105.49	\$20.43	\$22.00					
	2-Wire Analog Voice Grade Loop - (SL2) - UNE Zone 3			3	UEPPX	UEGD1		\$34.96	\$210.31	\$195.35	\$105.49	\$20.43	\$22.00					
	UNE Port Rate																	
	Exchange Ports - 2-Wire DID Port				UEPPX	UEPD1		\$10.94	\$238.69	\$37.49	\$119.40	\$7.50	\$22.00					
	NONRECURRING CHARGES - CURRENTLY COMBINED																	
	2-Wire Voice Grade Loop / 2-Wire DID Trunk Port Conversion with Bellsouth Allowable Changes				UEPPX	USATC		\$14.62	\$3.73				\$22.00					
	NONRECURRING CHARGES (NRCS) - NEW							\$34.92	\$27.66									
	ADDITIONAL NRCS																	
	2-Wire DID Subsequent Activity - Add Trunks, Per Trunk				UEPPX	USAS1		\$53.58	\$53.58				\$22.00					
	Telephone Number/Trunk Group Establishment Charges																	
	DID Trunk Termination (One Per Port)				UEPPX	NDT		\$0.00	\$0.00	\$0.00			\$22.00					
	Additional DID Numbers for each Group of 20 DID Numbers				UEPPX	ND4		\$0.00	\$0.00	\$0.00			\$22.00					
	DID Numbers, Non- consecutive DID Numbers, Per Number				UEPPX	ND5		\$0.00	\$0.00	\$0.00			\$22.00					
	Reserve Non-Consecutive DID numbers				UEPPX	ND6		\$0.00	\$0.00	\$0.00			\$22.00					
	Reserve DID Numbers				UEPPX	NDV		\$0.00	\$0.00	\$0.00			\$22.00					
	LOCAL NUMBER PORTABILITY																	
	Local Number Portability (1 per port)				UEPPX	LNPCP		\$3.15										
	2-WIRE ISDN DIGITAL GRADE LOOP WITH 2-WIRE ISDN DIGITAL LINE SIDE PORT																	
	UNE Port/Loop Combination Rates																	
	2-W ISDN Digital Grade Loop/2W ISDN Digital Line Side Port - UNE Zone 1			1	UEPPB	UEPPB		\$85.40										
	2-W ISDN Digital Grade Loop/2W ISDN Digital Line Side Port - UNE Zone 2			2	UEPPB	UEPPB		\$44.09										
	2-W ISDN Digital Grade Loop/2W ISDN Digital Line Side Port - UNE Zone 3			3	UEPPB	UEPPB		\$65.35										
	UNE Loop Rates																	
	2-Wire ISDN Digital Grade Loop - UNE Zone 1			1	UEPPB	UEPPR		\$22.41	\$233.47	\$158.51	\$105.49	\$20.48	\$22.00					
	2-Wire ISDN Digital Grade Loop - UNE Zone 2			2	UEPPB	UEPPR		\$31.10	\$233.47	\$158.51	\$105.49	\$20.48	\$22.00					
	2-Wire ISDN Digital Grade Loop - UNE Zone 3			3	UEPPB	UEPPR		\$42.36	\$233.47	\$158.51	\$105.49	\$20.48	\$22.00					

BELLSOUTH / ATT RATES
Unbundled Network Elements
KENTUCKY

CATEGORY	NOTES	UNBUNDLED NETWORK ELEMENT	Interm	Zone	BCS	USOC	Rec	RATES				OSS RATES					
								Nonrecuring	First	Adtl	Discont	First	Adtl	SOMEC	SOMAN	SOMAN	SOMAN
UNE Port Rate	Exchange Port - 2-Wire ISDN Line Side Port				UEPPB UEPPR	UEPPB	\$12.99	\$145.59	\$106.01	\$95.93	\$21.55						
NONRECURRING CHARGES - CURRENTLY COMBINED	2-Wire ISDN Digital Grade Loop / 2-Wire ISDN Line Side Port Combination - Conversion				UEPPB UEPPR	USACB	\$0.0	\$177.04	\$54.04				\$22.00				
NONRECURRING CHARGES (NRCS) - NEW								\$319.40	\$288.11								
ADDITIONAL NRCS																	
LOCAL NUMBER PORTABILITY	Local Number Portability (1 per port)				UEPPB UEPPR	LNPCX	\$0.35	\$0.00	\$0.00								
B-CHANNEL USER PROFILE ACCESS:																	
	CVS/CSD (DMS/RESS)				UEPPB UEPPR	U1UCA	\$0.00	\$0.00	\$0.00								
	CVS (EWS/D)				UEPPB UEPPR	U1UCB	\$0.00	\$0.00	\$0.00								
	CSD				UEPPB UEPPR	U1UCG	\$0.00	\$0.00	\$0.00								
B-CHANNEL AREA PLUS USER PROFILE ACCESS: (AL, KY, LA, MS, SC, MS, & TN)																	
	CVS/CSD (DMS/RESS)				UEPPB UEPPR	U1UCD	\$0.00	\$0.00	\$0.00								
	CVS (EWS/D)				UEPPB UEPPR	U1UCE	\$0.00	\$0.00	\$0.00								
	CSD				UEPPB UEPPR	U1UCF	\$0.00	\$0.00	\$0.00								
USER TERMINAL PROFILE	User Terminal Profile (EWS/D only)				UEPPB UEPPR	U1UMA	\$0.00	\$0.00	\$0.00								
VERTICAL FEATURES	All Vertical Features - One per Channel B User Profile				UEPPB UEPPR	UEVVF	\$3.39	\$0.00	\$0.00								
INTEROFFICE CHANNEL MILEAGE	Interoffice Channel mileage each, including first mile and facilities termination				UEPPB UEPPR	MTGNC	\$26.98	\$142.31	\$56.21				\$0.0				
	Interoffice Channel mileage each, additional mile				UEPPB UEPPR	MTGNM	\$0.0301	\$0.00	\$0.00				\$0.0				
4-WIRE DST1 DIGITAL LOOP WITH 4-WIRE ISDN DST1 DIGITAL TRUNK PORT																	
UNE Port/Loop Combination Rates																	
	4W/DST1 Digital Loop/4W/ISDN DST1 Digital Trunk Port - UNE Zone 1				UEPPP		\$21.925										
	4W/DST1 Digital Loop/4W/ISDN DST1 Digital Trunk Port - UNE Zone 2				UEPPP		\$248.36										
	4W DST1 Digital Loop/4W/ISDN DST1 Digital Trunk Port - UNE Zone 3				UEPPP		\$289.47										
UNE Loop Rates																	
	4-Wire DST1 Digital Loop - UNE Zone 1				UEPPP	US14P	\$106.04	\$505.12	\$315.18	\$89.11	\$23.33		\$22.00				
	4-Wire DST1 Digital Loop - UNE Zone 2				UEPPP	US14P	\$135.15	\$505.10	\$315.18	\$89.11	\$23.33		\$22.00				
	4-Wire DST1 Digital Loop - UNE Zone 3				UEPPP	US14P	\$186.15	\$505.10	\$315.18	\$89.11	\$23.33		\$22.00				
UNE Port Rate	Exchange Ports - 4-Wire ISDN DST1 Port				UEPPP		\$113.21	\$407.77	\$203.18	\$157.77	\$39.98		\$22.00				
NONRECURRING CHARGES - CURRENTLY COMBINED	4-Wire DST1 Digital Loop / 4-Wire ISDN DST1 Digital Trunk Port Combination - Conversion - Switch-as-is				UEPPP	USACP	\$0.00	\$238.22	\$157.17				\$22.00				

BELLSOUTH / ATT RATES
Unbundled Network Elements
KENTUCKY

CATEGORY	NOTES	UNBUNDLED NETWORK ELEMENT	Interim	Zone	BOS	USOC	Reg	RATES				OSS RATES										
								Nonrecuring	First	Advtl	Disconnect	First	Advtl	SOMEC	SOMAN	SOMAN	SOMAN	SOMAN	SOMAN			
NONRECURRING CHARGES (NRCS) - NEW	ADDITIONAL NRCS 4-Wire DS1 Loop/4-Wire ISDN Digt Trk Port - Subseq Actv- Inwardtwo way tel nos within Sld Allowance 4-Wire DS1 Loop / 4-Wire ISDN DS1 Digital Trunk Port - Outward Tel Numbers (All States except NC) 4-Wire DS1 Loop / 4-Wire ISDN DS1 Digital Trk Port - Subsequent Inward Tel Nos Above Sld Allowance							\$733.57	\$381.40													
LOCAL NUMBER PORTABILITY	Local Number Portability (1 per port)							\$1.75														
INTERFACE (provisioning Only)	Voice/Data Digital Data Inward Data								\$0.00	\$0.00	\$0.00	\$0.00										
New or Additional 'B' Channel	New or Additional - Voice/Data B Channel New or Additional - Digital Data B Channel New or Additional Usage Sensitive Voice Data B Channel New or Additional Usage Sensitive Digital Data B Channel							\$0.00	\$29.06	\$29.06	\$22.00											
CALL TYPES	Inward Outward Two-way								\$0.00	\$0.00	\$0.00	\$0.00										
Interoffice Channel Mileage	Fixed Each Including First Mile Each Airline-Fractional Additional Mile								\$55.50	\$298.18	\$231.23	\$0.00										
4-WIRE DS1 DIGITAL LOOP WITH 4-WIRE DDITS TRUNK PORT																						
UNE Port/Loop Combination Rates	4W/DS1 Digital Loop/4W/DDITS Trunk Port - UNE Zone 1 4W/DS1 Digital Loop/4W/DDITS Trunk Port - UNE Zone 2 4W/DS1 Digital Loop/4W/DDITS Trunk Port - UNE Zone 3								\$189.32	\$218.43	\$22.00											
UNE Loop Rates	4-Wire DS1 Digital Loop - UNE Zone 1 4-Wire DS1 Digital Loop - UNE Zone 2 4-Wire DS1 Digital Loop - UNE Zone 3								\$106.04	\$505.10	\$315.18	\$89.11	\$23.33	\$22.00								
UNE Port Rate	4-Wire DDITS Digital Trunk Port								\$83.28	\$404.18	\$191.44	\$144.77	\$4.90	\$22.00								
NONRECURRING CHARGES - CURRENTLY COMBINED	4-Wire DS1 Digital Loop / 4-Wire DDITS Trunk Port Combination - Switch-asis 4-Wire DS1 Digital Loop / 4-Wire DDITS Trunk Port Combination - Conversion with DS1 Changes 4-Wire DS1 Digital Loop / 4-Wire DDITS Trunk Port Combination - Conversion with Change - Trunk								\$261.15	\$134.08	\$22.00											
NONRECURRING CHARGES - NEW									\$261.15	\$134.08	\$22.00											

BELLSOUTH/ ATT RATES
Unbundled Network Elements
KENTUCKY

CATEGORY	NOTES	UNBUNDLED NETWORK ELEMENT	Interim	Zone	BOS	USOC	Rec	RATES				OSS RATES																
								Nonrecurring		Disconnect		SOMEC	SOMAN	SOMAN	SOMAN	SOMAN	SOMAN											
								Frs1	Addl	Frs1	Addl																	
ADDITIONAL NRCS	4-Wire DS1 Loop / 4-Wire DDTTS Trunk Port - NRC - Subsequent Channel Activation/Chan - 2-Way Trunk				UEPDC	UDTTA																						
	4-Wire DS1 Loop / 4-Wire DDTTS Trunk Port - Subsequent Channel Activation/Chan - 1-Way Outward Trunk				UEPDC	UDTTB																						
	4-Wire DS1 Loop / 4-Wire DDTTS Trunk Port - Subsequent Channel Activation/Chan Inward Trunk w/out DID				UEPDC	UDTTC																						
	4-Wire DS1 Loop / 4-Wire DDTTS Trunk Port - Subsqnt Chan Activation Per Chan - Inward Trunk with DID				UEPDC	UDTTD																						
	4-Wire DS1 Loop / 4-Wire DDTTS Trunk Port - Subsqnt Chan Activation / Chan - 2-Way DID w User Trans				UEPDC	UDTTE																						
	BIPOLAR 8 ZERO SUBSTITUTION																											
	8x2S - Superframe Format					UEPDC	CCOSF																					
	8x2S - Extended Superframe Format					UEPDC	CCOEF																					
	Alternate Mark Inversion																											
	AMI - Superframe Format					UEPDC	MCOSF																					
	AMI - Extended Superframe Format					UEPDC	MCOP0																					
	Telephone Number/Trunk Group Establishment Charges																											
Telephone Number for 2-Way Trunk Group					UEPDC	UDTGX	\$0.00																					
Telephone Number for 1-Way Outward Trunk Group					UEPDC	UDTGY	\$0.00																					
Telephone Number for 1-Way Inward Trunk Group Without DID					UEPDC	UDTGZ	\$0.00																					
DID Numbers for each Group of 20 DID Numbers					UEPDC	ND4	\$0.00																					
DID Numbers, Non- consecutive DID Numbers, Per Number					UEPDC	ND5	\$0.00																					
Reserve Non-Consecutive DID Nos.					UEPDC	ND6	\$0.00																					
Reserve DID Numbers					UEPDC	NDV	\$0.00																					
Dedicated DS1 (Interoffice Channel Mileage) - FX/CO for 4-Wire DS1 Digital Loop with 4-Wire DDTTS Trunk Port																												
Interoffice Channel Mileage - Fixed rate 0-8 miles (Facilities Termination)					UEPDC	11NO1	\$55.05	\$298.18	\$231.23	\$0.00	\$0.00																	
Interoffice Channel Mileage - Additional rate per mile - 0-8 miles (Termination)					UEPDC	11NOA	\$0.45	\$0.00	\$0.00																			
Interoffice Channel Mileage - Fixed rate 9-25 miles (Facilities Termination)					UEPDC	11NO2	\$0.00	\$0.00	\$0.00																			
Interoffice Channel Mileage - Additional rate per mile - 9-25 miles (Termination)					UEPDC	11NOB	\$0.450	\$0.00	\$0.00																			
Interoffice Channel Mileage - Fixed rate 25+ miles (Facilities Termination)					UEPDC	11NO3	\$0.00	\$0.00	\$0.00																			
Interoffice Channel Mileage - Additional rate per mile - 25+ miles (Local Number Portability, per DS0 Activated)					UEPDC	11NOC	\$0.450	\$0.00	\$0.00																			
Central Office Terminating Point					UEPDC	LNCP	\$3.15	\$0.00	\$0.00																			
					UEPDC	CTG	\$0.00																					
4-WIRE DS1 LOOP WITH CHANNELIZATION WITH PORT																												
System is 1 DS1 Loop, 1 D4 Channel Bank, and up to 24 Feature Activations																												
Each System can have up to 24 combinations of rates depending on type and number of ports used																												
UNE DS1 Loop																												
4-Wire DS1 Loop - UNE Zone 1					UEPMG	USLDC	\$106.04	\$0.00	\$0.00																			
4-Wire DS1 Loop - UNE Zone 2					UEPMG	USLDC	\$135.15	\$0.00	\$0.00																			
4-Wire DS1 Loop - UNE Zone 3					UEPMG	USLDC	\$186.15	\$0.00	\$0.00																			
UNE DSO Channelization Capacities (D4 Channel Bank Configurations)																												

BELLSOUTH/ ATT RATES
Unbundled Network Elements
KENTUCKY

Attachment 2
Exhibit A(2)
Rates - Page 11

CATEGORY	NOTES	UNBUNDLED NETWORK ELEMENT	Interim	Zone	BCS	USOC	Rec	RATES				OSS RATES								
								Nonrecurring	First	Add'l	Disconnect	First	Add'l	SOMEC	SOMAN	SOMAN	SOMAN	SOMAN	SOMAN	
		24 DSO Channel Capacity - 1 per DS1			UEPMG	VUM24	\$136.99	\$0.00	\$0.00	\$0.00										
		48 DSO Channel Capacity - 1 per 2 DS1s			UEPMG	VUM48	\$273.98	\$0.00	\$0.00	\$0.00										
		96 DSO Channel Capacity - 1 per 4 DS1s			UEPMG	VUM96	\$547.96	\$0.00	\$0.00	\$0.00										
		144 DSO Channel Capacity - 1 per 6 DS1s			UEPMG	VUM144	\$821.94	\$0.00	\$0.00	\$0.00										
		192 DSO Channel Capacity - 1 per 8 DS1s			UEPMG	VUM192	\$1,095.92	\$0.00	\$0.00	\$0.00										
		240 DSO Channel Capacity - 1 per 10 DS1s			UEPMG	VUM240	\$1,369.90	\$0.00	\$0.00	\$0.00										
		288 DSO Channel Capacity - 1 per 12 DS1s			UEPMG	VUM288	\$1,643.88	\$0.00	\$0.00	\$0.00										
		384 DSO Channel Capacity - 1 per 16 DS1s			UEPMG	VUM384	\$2,191.84	\$0.00	\$0.00	\$0.00										
		480 DSO Channel Capacity - 1 per 20 DS1s			UEPMG	VUM480	\$2,739.80	\$0.00	\$0.00	\$0.00										
		576 DSO Channel Capacity - 1 per 24 DS1s			UEPMG	VUM576	\$3,287.76	\$0.00	\$0.00	\$0.00										
		672 DSO Channel Capacity - 1 per 28 DS1s			UEPMG	VUM672	\$3,835.72	\$0.00	\$0.00	\$0.00										
		Non-Recurring Charges (NRC) Associated with 4-Wire DS1 Loop with Channelization with Port - Conversion Charge Based on a System																		
		A Minimum System Configuration is One (1) DS1, One (1) D4 Channel Bank, and Up To 24 DSO Ports with Feature Activations.																		
		Multiples of this configuration functioning as one are considered Add'l after the minimum system configuration is counted.																		
		NRC - Conversion (Currently Combined) with or without BellSouth Allowed Changes			UEPMG	USAC4	\$0.00	\$301.05	\$16.72											
		4-Wire DS1 Loop/Channelization/2-Wire VG Line Port Combination-New (KY)						\$724.72	\$476.47											
		System Additions at End User Location's Where 4-Wire DS1 Loop with Channelization with Port Combination Currently Exists and New (Not Currently Combined) in Georgia Only																		
		NRC - 1 DS1/D4 Channel Bank - Add NRC for each Port and Assoc Feature Activation - New GA Only			UEPMG	VUMD4	\$0.00	\$716.36	\$488.20	\$149.30	\$17.71									
		Bipolar 8 Zero Substitution																		
		Clear Channel Capability Format, superframe - Subsequent Activity Only			UEPMG	CCOSF	\$0.00	\$0.00	\$730.00											
		Clear Channel Capability Format - Extended Superframe - Subsequent Activity Only			UEPMG	CCOEF	\$0.00	\$0.00	\$730.00											
		Alternate Mark Inversion (AMI)																		
		Superframe Format			UEPMG	MCOSE	\$0.00	\$0.00	\$0.00	\$0.00										
		Extended Superframe Format			UEPMG	MCOPO	\$0.00	\$0.00	\$0.00											
		Exchange Ports Associated with 4-Wire DS1 Loop with Channelization with Port																		
		Exchange Ports																		
		Line Side Combination Channelized PBX Trunk Port - Business			UEPPX	UEPCK	\$1.66	\$0.00	\$0.00	\$0.00										
		Line Side Outward Channelized PBX Trunk Port - Business			UEPPX	UEPOX	\$1.66	\$0.00	\$0.00	\$0.00										
		Line Side Inward Only Channelized PBX Trunk Port without DID			UEPPX	UEPIX	\$1.66	\$0.00	\$0.00	\$0.00										
		2-Wire Trunk Side Unbundled Channelized DID Trunk Port			UEPPX	UEPDM	\$10.97	\$0.00	\$0.00	\$0.00										
		Feature Activations - Unbundled Loop Concentration																		
		Feature (Service) Activation for each Line Side Port Terminated in D4 Bank			UEPPX	FP0WM	\$0.77	\$25.40	\$13.41	\$4.17	\$4.15									

BELLSOUTH / ATT RATES
Unbundled Network Elements
KENTUCKY

CATEGORY	NOTES	UNBUNDLED NETWORK ELEMENT	Interim	Zone	BCS	USOC	Rec	RATES				OSS RATES								
								Nonrecurring		Disconnect		SOMEC	SOMAN	SOMAN	SOMAN	SOMAN	SOMAN	SOMAN		
								First	Add'l	First	Add'l									
	Feature (Service) Activation for each Trunk Side Port Terminated in DA Bank				UEFPX	FPQWU	\$0.77	\$78.15	\$19.68	\$59.05	\$11.54									
	Telephone Number/ Group Establishment Charges for DID Service				UEFPX	NDT	\$0.00	\$0.00	\$0.00											
	DID Trunk Termination (1 per Port)				UEFPX	ND4	\$0.00	\$0.00	\$0.00											
	DID Numbers - groups of 20 - Valid all States				UEFPX	ND5	\$0.00	\$0.00	\$0.00			\$22.00								
	Non-Consecutive DID Numbers - per number				UEFPX	ND6	\$0.00	\$0.00	\$0.00			\$22.00								
	Reserve Non-Consecutive DID Numbers				UEFPX	NDV	\$0.00	\$0.00	\$0.00											
	Reserve DID Numbers				UEFPX		\$0.00	\$0.00	\$0.00											
	Local Number Portability				UEFPX	LNPGP	\$3.15	\$0.00	\$0.00											
	Local Number Portability - 1 per port				UEFPX															
	FEATURES - Vertical and Optional																			
	Local Switching Features Offered with Line Side Ports Only				UEFPX	UEPVF	\$3.39	\$0.00	\$0.00											\$22.00
	All Features Available																			

CALLING NAME DELIVERY (CNAM) DATABASE SERVICES

1. Definitions

1.1 For the purpose of this Exhibit B, the following terms shall be defined as:

1.1.1 **CALLING NAME DELIVERY DATABASE SERVICE (CNAM)** - The ability to **associate** a name with the calling party number, allowing the end user subscriber (to which a call is being terminated) to view the calling party's name before the call is answered. This service also provides AT&T the opportunity to load and store its subscriber names in the BellSouth CNAM SCPs.

1.1.2 **CALLING PARTY NUMBER (CPN)** - The number of the calling party that is delivered to the terminating switch using common channel signaling system 7 (CCS7) technology, and that is contained in the Initial Address Message (IAM) portion of the CCS7 call setup.

1.1.3 **COMMON CHANNEL SIGNALING SYSTEM 7 (CCS7)** - A network signaling technology in which all signaling information between two or more nodes is transmitted over high-speed data links, rather than over voice circuits.

1.1.4 **SERVICE CONTROL POINTs (SCPs)** - The real-time data base systems that contain the names to be provided in response to queries received from CNAM SSPs.

1.1.5 **SERVICE MANAGEMENT SYSTEM (SMS)** - The main operations support system of CNAM DATABASE SERVICE. CNAM records are loaded into the SMS, which in turn downloads into the CNAM SCP.

1.1.6 **SERVICE SWITCHING POINTs (SSPs)** - Features of computerized switches in the telephone network that determine that a terminating line has subscribed to CNAM service, and then communicate with CNAM SCPs in order to provide the name associated with the calling party number.

1.1.7 **SUBSYSTEM NUMBER (SSN)** - The address used in the Signaling Connection Control Part (SCCP) layer of the SS7 protocol to designate an application at an end signaling point. A SSN for CNAM at the end office designates the CNAM application within the end office. BellSouth uses the CNAM SSN of 232.

2. Exhibit C

2.1 This Exhibit C contains the terms and conditions where BellSouth will provide to the AT&T access to the BellSouth CNAM SCP for query or record storage purposes.

2.2 AT&T shall submit to BellSouth a notice of its intent to access and utilize BellSouth CNAM Database Services pursuant to the terms and conditions of this Exhibit C. Said notice shall be in writing, no less than 60 days prior to AT&T's access to BellSouth's CNAM Database Services and shall be addressed to AT&T's Account Manager.

3. Physical Connection and Compensation

3.1 BellSouth's provision of CNAM Database Services to AT&T requires interconnection from AT&T to BellSouth CNAM Service Control Points (SCPs). Such interconnections shall be established pursuant to Attachment 3 of this Agreement. The appropriate charge for access to and use of the BellSouth CNAM Database service shall be as set forth in this Exhibit C.

3.2 In order to formulate a CNAM query to be sent to the BellSouth CNAM SCP, AT&T shall provide its own CNAM SSP. AT&T's CNAM SSPs must be compliant with TR-NWT-001188, "CLASS Calling Name Delivery Generic Requirements".

3.3 If AT&T elects to access the BellSouth CNAM SCP via a third party CCS7 transport provider, the third party CCS7 provider shall interconnect with the BellSouth CCS7 network according to BellSouth's Common Channel Signaling Interconnection Guidelines and Telcordia (formerly BellCore)'s CCS Network Interface Specification document, TR-TSV-000905. In addition, the third party provider shall establish CCS7 interconnection at the BellSouth Local Signal Transfer Points (LSTPs) serving the BellSouth CNAM SCPs that AT&T desires to query.

3.4 Out-Of-Region Customers

If the customer queries the BellSouth CNAM SCP via a third party national SS7 transport provider, the third party SS7 provider shall interconnect with the BellSouth CCS7 network according to BellSouth's Common Channel Signaling Interconnection Guidelines and Telcordia's (formerly BellCore's) CCS Network Interface Specification document, TR-TSV-000905. In addition, the third party provider shall establish SS7 interconnection at one or more of the BellSouth Gateway Signal Transfer Points (STPs). The payment of all costs associated with the transport of SS7 signals via a third party will be

established by mutual agreement of the Parties in writing and shall, by this reference become an integral part of this Agreement.

4. CNAM Record Initial Load and Updates

- 4.1 The mechanism to be used by AT&T for initial CNAM record load and/or updates shall be determined by mutual agreement. The initial load and all updates shall be provided by AT&T in the BellSouth specified format and shall contain records for every working telephone number that can originate phone calls. It is the responsibility of AT&T to provide accurate information to BellSouth on a current basis.
- 4.2 Updates to the SMS shall occur no less than once a week, reflect service order activity affecting either name or telephone number, and involve only record additions, deletions or changes.
- 4.3 AT&T CNAM records provided for storage in the BellSouth CNAM SCP shall be available, on a SCP query basis only, to all Parties querying the BellSouth CNAM SCP. Further, CNAM service shall be provided by each Party consistent with state and/or federal regulation.

ATTACHMENT 3

LOCAL INTERCONNECTION

TABLE OF CONTENTS

1. NETWORK INTERCONNECTION.....	2
2. METHODS OF INTERCONNECTION	6
3. INTERCONNECTION TRUNKING AND ROUTING	9
5. NETWORK MAINTENANCE	24

EXHIBIT A

EXHIBIT B

EXHIBIT C

EXHIBIT D

EXHIBIT E

EXHIBIT F

LOCAL INTERCONNECTION

1. NETWORK INTERCONNECTION

- 1.1 The Parties shall provide interconnection with each other's network for the transmission and routing of telephone exchange service (local) and exchange access (intraLATA toll and switched access).
 - 1.1.1 BellSouth shall provide interconnection with BellSouth's network at any technically feasible point within BellSouth's network as described in 47 CFR §51.305.
 - 1.1.2 AT&T shall provide interconnection to BellSouth at any mutually agreed upon point.
- 1.2 AT&T must establish, at a minimum, a single Point of Presence, Physical Point of Interface, and interconnection trunk group with BellSouth within the LATA for the delivery of AT&T's originated local, intraLATA toll terminated to BellSouth and transit traffic terminated to other than BellSouth. If AT&T chooses to interconnect using a single interconnection trunk group within a LATA, the interconnection trunk group must be at a BellSouth access or local tandem. Furthermore, AT&T must establish an interconnection trunk group(s) at all BellSouth access and local tandems where AT&T NXXs are "homed." A "Homing" arrangement is defined by a "Final" Trunk Group between the BellSouth access or local tandem and AT&T End Office switch. A "Final" Trunk Group is the last choice telecommunications path between the access or local tandem and End Office switch. It is AT&T's responsibility to enter its own NPA/NXX access and/or local tandem "homing" arrangements into the national Local Exchange Routing Guide ("LERG"). In order for AT&T to home its NPA/NXX(s) on a BellSouth access or local tandem, AT&T's NPA/NXX(s) must be assigned to an exchange rate center area served by that BellSouth access or local tandem and as specified by BellSouth.
- 1.3 A Point of Presence is the physical location (a structure where the environmental, power, air conditioning, etc. specifications for a Party's terminating equipment can be met) at which a Party establishes itself for obtaining access to the other Party's network. The Point of Presence is the physical location within which the Point(s) of Interface occur.
- 1.4 A Physical Point of Interface is the physical telecommunications interface between BellSouth and AT&T's interconnection facilities. It establishes the technical interface and point of operational

responsibility. The primary purpose of the Point of Interface is to serve as the terminus for each Party's interconnection facilities. The Physical Point of Interface has the following main characteristics:

- 1.4.1 It is a cross-connect point to allow connection, disconnection, transfer or restoration of service.
- 1.4.2 It is a point where BellSouth and AT&T can verify and maintain specific performance objectives.
- 1.4.3 It is specified according to the interfaces offered in this Attachment 3.
- 1.5 Interconnection trunk groups are available at either access tandems, local tandems, End Offices, or any other technically feasible point, as described in this Agreement. AT&T's requested interconnection trunk groups will also be used for the receipt and delivery of transit traffic at BellSouth access and local tandems. Interconnection trunk groups established at the BellSouth local tandem apply only to AT&T-originated local and local originating and terminating transit traffic.
- 1.6 The Parties will work cooperatively to establish the most efficient trunking network in accordance with the provisions set forth in this Attachment 3 and accepted industry practices.
- 1.7 Each Party will be responsible for engineering its network (i.e., the underlying facilities on which trunks are provisioned) and providing, or causing to be provided, any necessary equipment on its side of the Physical Point of Interface.
- 1.8 A minimum of one Physical Point of Interface shall be established in each LATA in which AT&T originates, terminates, or exchanges local traffic or ISP-bound traffic and interconnects with BellSouth. The location of the initial Physical Point of Interface shall be established by mutual agreement of the Parties. In selecting the initial Physical Point of Interface, both Parties will act in good faith and select the point that is most efficient for both Parties. Each Party shall be responsible for engineering and maintaining the network on its side of the Physical Point of Interface. Establishment of an Initial Physical Point of Interface will be initiated by written request and will be based on traffic volumes and patterns, facilities available, and other factors unique to the area. If the Parties are not able to reach mutual agreement on an initial Physical Point of Interface within thirty (30) calendar days of the date of the written request, each Party will designate the initial Physical Point of Interface for its originated traffic.
- 1.8.1 Additional Points of Interface in a particular LATA may be established by mutual agreement of the Parties. Absent mutual agreement, in order to establish additional Points of Interface in a LATA, the traffic

originated from AT&T or BellSouth destined to the other Party at the proposed additional Point of Interface must exceed 8.9 million minutes of local or ISP-bound traffic per month for three consecutive months. Additionally, any end office to be designated as a Point of Interface must be more than 25 miles from an existing Point of Interface. AT&T may designate one additional Point of Interface per state without qualification during the term of this Agreement. BellSouth will not designate a Point of Interface at a Central Office where physical or virtual collocation space or BellSouth fiber connectivity is not available.

- 1.8.2 Upon written notification from the Party requesting the establishment of an additional Point of Interface, the receiving Party has forty-five (45) calendar days to analyze, respond to, and negotiate in good faith the establishment of and location of such additional Point of Interface. If the receiving Party disagrees that the traffic and mileage thresholds set forth herein have been met, then the requesting Party may utilize the dispute resolution procedure set forth in this Agreement. The Parties recognize that they have in their networks existing Points of Interface established under previous interconnection agreements. The Parties further recognize that there are switching locations that would immediately qualify upon the signing of this Agreement to be established as additional Points of Interface. Effective on the date this Agreement is signed, the Parties agree that such existing switching locations will be transitioned to additional Points of Interface in accordance with the following schedule: for the first year of this Agreement, no more than one (1) existing switching location will be transitioned to an additional Point of Interface per LATA per six (6) months. For the remaining term of this Agreement, no more than two (2) existing switching locations will be transitioned to additional Points of Interface per LATA per six (6) month period.
- 1.8.3 A Billing Point of Interface ("BPOI") is defined as the Point of Interface specified by BellSouth for delivery of BellSouth originated traffic to AT&T for which AT&T agrees to pay BellSouth for Interoffice Dedicated Transport and associated Multiplexing for BellSouth to transport Local Traffic and ISP-bound Traffic from the BPOI to the Physical Point of Interface designated by AT&T when AT&T does not want to establish a Physical Point of Interface as set forth in Section 1.4 above. Compensation for said transport and multiplexing is as set forth in the Interconnection Compensation section of this Attachment.
- 1.9 With the exception of the Billing Point of Interface, Multiplexing compensation and Transit Traffic compensation, the Parties shall institute a "bill and keep" compensation plan under which neither Party will charge the other Party recurring and nonrecurring charges for trunks (one-way or two-way) and associated dedicated facilities for the

exchange of Local Traffic (non-transit) and ISP-bound Traffic. Each Party has the obligation to install the appropriate trunks and associated facilities on its respective side of the Interconnection Point and is responsible for bearing its own costs on its side of the Point of Interface. Both Parties, as appropriate, shall be compensated for the ordering of trunks and facilities used exclusively for Transit Traffic and for ancillary traffic types including, but not limited to, 911 and OS/DA. The Parties agree that charges for such trunks and facilities are as set forth in Exhibit A to this Attachment or the applicable tariff. In the event that a Party chooses to lease facilities from the other Party in lieu of installing facilities on its side of the Interconnection Point as required by this Agreement, such facilities are not subject to "bill and keep," but shall be purchased in accordance with 1.9.1 and 1.9.2.

- 1.9.1 In lieu of providing facilities on its side of Interconnection Point, either Party may purchase Local Channel facilities from the other Party, at the cost-based rates identified in Exhibit A to this Attachment, from the leasing Party's switch or Point of Presence to that Party's serving wire center. The portion of Local Channel facilities utilized for Local Traffic and ISP-bound Traffic shall be determined based upon the application of the Percent Local Facility ("PLF") Factor as defined in this Attachment. Additionally, the charges applied to the portion of the Local Channel used for Local Traffic and ISP-bound Traffic as determined by the PLF are as set forth in Exhibit A to this Attachment. This factor shall be reported in addition to the switched dedicated transport jurisdictional factors specified in the BellSouth intrastate and interstate switched access tariffs.
- 1.9.2 Additionally, in lieu of providing facilities on its side of the Interconnection Point, either Party may purchase, at the cost-based rates identified in Exhibit A to this Attachment, Dedicated Interoffice Transport facilities from its designated serving wire center to the Interconnection Point. The portion of Dedicated Interoffice Transport facilities utilized for Local Traffic and ISP-bound Traffic shall be determined based upon the application of the Percent Local Facility (PLF) Factor as defined in this Attachment. Additionally, the charges applied to the portion of the Dedicated Interoffice Transport used for Local Traffic and ISP-bound Traffic as determined by the PLF are as set forth in Exhibit A to this Attachment. This factor shall be reported in addition to the switched dedicated transport jurisdictional factors specified in the BellSouth intrastate and interstate switched access tariffs.
- 1.10 For the purposes of this Attachment 3, Local Channel is defined as a switch transport facility between a Party's Point of Presence and its designated serving wire center.

- 1.11 For the purposes of this Attachment 3, Serving Wire Center is defined as the wire center owned or leased by one Party from which the other Party would normally obtain dial tone for its Point of Presence.
- 1.12 For the purposes of this Attachment 3, Dedicated Transport is defined as a switch transport facility between a Party's designated serving wire center and the first point of switching on the other Party's common (shared) network.

2. METHODS OF INTERCONNECTION

- 2.1 AT&T may specify one or more of the following methods to interconnect with the BellSouth network:
- 2.1.1 Collocation - BellSouth shall provide collocation to AT&T pursuant to the terms set forth in Attachment 4 of this Agreement, incorporated herein by this reference. AT&T may, at its option, purchase such collocation at the rates, terms, and conditions set forth in Attachment 4 of this Agreement, incorporated herein by this reference.
- 2.1.2 Leased Facilities - where AT&T utilizes the facilities offered by BellSouth. Such leased facilities shall be provided at the rates, terms, and conditions set forth in this Attachment 3 pursuant to Section 1.9-1.9.2. At AT&T's request, it may lease separate facilities for the sole purpose of delivering undipped 8YY traffic from AT&T's end users to BellSouth's Service Switching Port ("SSP") for dipping into BellSouth's toll free database.
- 2.1.3 Third Party Facilities - where AT&T utilizes the facilities provided by a source other than itself or BellSouth. AT&T shall comply with industry standards to maintain network integrity and will be solely responsible for any charges or fees assessed by the third party for use of its facilities.
- 2.1.4 Commercial Intra-building Interconnection – where both Parties have constructed broadband facilities into a commercial building (i.e., a building that is not a telephone central office) and agree to establish a Point of Interface at such location utilizing intra-building cable.
- 2.1.5 "Fiber Meet" is an interconnection arrangement whereby the Parties physically interconnect their networks via an optical fiber interface (as opposed to an electrical interface), at which one Party's facilities, provisioning, and maintenance responsibility begins and the other Party's responsibility ends (i.e., Point of Interface). A Fiber Meet shall be an arrangement as set forth in Section 2.3 of this Attachment 3.

- 2.1.6 Any other method determined to be technically feasible and requested by AT&T shall be done pursuant to the process defined in Attachment 10 of this Agreement, incorporated herein by this reference.
- 2.2 BellSouth may specify one or more of the following to interconnect with the AT&T network:
- 2.2.1 Collocation - AT&T, at its sole discretion, may permit BellSouth to utilize space and power in AT&T facilities specified by AT&T solely for the purpose of terminating BellSouth's local traffic. BellSouth may request installation of both cable and equipment, or cable only. The pricing, terms and conditions of such arrangement shall be pursuant to Exhibit B of this Attachment 3, incorporated herein by this reference.
- 2.2.2 Leased Facilities - where the Party requesting interconnection utilizes the facilities offered by the other Party pursuant to Section 1.9-1.92. Such leased facilities shall be provided at the rates, terms, and conditions set forth in this Attachment 3.
- 2.2.3 Third Party Facilities - where BellSouth utilizes the facilities provided by a source other than itself or AT&T. BellSouth shall comply with industry standards to maintain network integrity and will be solely responsible for any charges or fees assessed by the third party for use of its facilities.
- 2.2.4 Commercial Intra-building Interconnection – where both Parties have constructed broadband facilities into a commercial building (i.e., a building that is not a telephone central office) and agree to establish a Point of Interface at such location utilizing intra-building cable.
- 2.2.5 "Fiber Meet" is an interconnection arrangement whereby the Parties physically interconnect their networks via an optical fiber interface (as opposed to an electrical interface), at which one Party's facilities, provisioning, and maintenance responsibility begins and the other Party's responsibility ends (i.e., Point of Interface). A Fiber Meet shall be an arrangement as set forth in Section 2.3 of this Attachment 3.
- 2.2.6 Any other method determined to be technically feasible and requested by BellSouth and agreed to by AT&T shall be done.

2.3 Fiber Meet

- 2.3.1 If AT&T elects to establish a Point of Interface with BellSouth pursuant to a Fiber Meet, AT&T and BellSouth shall jointly engineer and operate a Synchronous Optical Network ("SONET") transmission system by which they shall interconnect their transmission and routing of local traffic via a Local Channel facility at either the DS0, DS1, or DS3 level and shall be ordered via an Access Services Request ("ASR") in the

initial phase of this offering. The Parties shall work jointly to determine the specific transmission system. The parties will work cooperatively to establish joint access to transmission overhead signals and commands for such facilities and software. However, AT&T's SONET transmission must be compatible with BellSouth's equipment in the serving wire center. The Parties will work cooperatively in the selection of compatible transmission equipment and software. Fiber Meet will be used for the provision of two-way trunking unless otherwise agreed to by the Parties.

- 2.3.2 BellSouth shall, wholly at its own expense, procure, install and maintain the agreed upon SONET equipment in the BellSouth Serving Wire Center ("BSWC").
- 2.3.3 AT&T shall, wholly at its own expense, procure, install and maintain the agreed upon SONET equipment in the AT&T Serving Wire Center ("ASWC").
- 2.3.4 The parties shall mutually agree upon a Point of Interface outside of the BSWC as a Fiber Meet point and shall make all necessary preparations to receive and to allow and enable delivery of fiber optic facilities into the Point of Interface with sufficient spare length to reach the Point of Interface. A Common Language Location Identification ("CLLI") code will be established for each Point of Interface. The code established must be a building type code. All orders shall originate from the Point of Interface (i.e., Point of Interface to AT&T, Point of Interface to BellSouth).
- 2.3.5 The Parties shall deliver and maintain their own strands wholly at their own expense. Upon verbal request by either Party, the other Party shall allow access to the Fiber Meet entry point for maintenance purposes as promptly as possible.
- 2.3.6 The Parties shall jointly coordinate and undertake maintenance of the SONET transmission system. Each Party shall be responsible for maintaining the components of their own SONET transmission system.
- 2.3.7 Each Party will be responsible for (i) providing its own transport facilities to the Fiber Meet, and (ii) the cost to build-out its facilities to such Fiber Meet.
- 2.3.8 Neither Party shall charge the other for its portion of the Fiber Meet facility between the ASWC and the BSWC used exclusively for the other Party's local traffic (i.e., the Local Channel). The Parties do not intend to utilize this arrangement for transit traffic.

3. INTERCONNECTION TRUNKING AND ROUTING

- 3.1 The Parties will convert all existing interconnection arrangements and trunks to the interconnection arrangements described in this Attachment in accordance with the following:
- 3.1.1 Within forty-five (45) days of either Party's written request, the Parties will mutually develop an operations plan based on sound engineering and operations principles, which will specify the guidelines to convert from the existing interconnection arrangements to the interconnection arrangements described in this Attachment 3. Such guidelines will conform to standard industry practices adopted by and contained in documents published by Industry Forums, including but not limited to, the Alliance for Telecommunications Industry Solutions ("ATIS") and the Ordering and Billing Forum ("OBF").
- 3.1.2 Each Party shall bear its own costs to convert from the existing interconnection arrangements to the interconnection arrangements described in this Attachment.
- 3.1.3 Unless otherwise mutually agreed, the Parties will complete the conversion within one (1) year of the Requesting Party's written request.
- 3.1.4 If, following one (1) year after the Requesting Party's written request, there exists any interconnection trunks which have not been converted to the interconnection arrangements described in this Attachment 3, then either Party may invoke the dispute resolution proceeding, pursuant to Section 16 of the General Terms and Conditions of this Agreement, incorporated herein by this reference.
- 3.2 The Parties will use the following interconnection standards:
- 3.2.1 The Parties agree to establish Binary 8 Zero Sum Extended Superframe line protocol, where technically feasible.
- 3.2.2 In those cases where either Party's equipment will not support 64K Clear Channel Capability ("CCC"), the Parties agree to establish AMI line coding. Any AMI line coding will be Superframe formatted. DS3 facilities will be provisioned with C-bit parity.
- 3.2.3 Where additional equipment is required, such equipment shall be obtained, engineered, and installed to support 64K CCC trunks.
- 3.2.4 All interconnection facilities between the Parties will be sized according to mutual forecasts developed per the requirements of Section 4.14 of this Attachment 3 and sound engineering practices.

3.2.5 Interconnection will be provided utilizing either a DS1 or DS3 interface or, with the mutual agreement of the Parties, another technically feasible interface (e.g., STS-1).

3.3 Trunking Arrangements

3.3.1 **Local Tandem Interconnection**. This interconnection arrangement allows AT&T to establish interconnection trunk group(s) at BellSouth local tandems for: (1) the delivery of AT&T-originated local traffic transported and terminated by BellSouth to BellSouth end offices within the local calling area as defined in BellSouth's General Subscriber Services Tariff, Section A3 served by those BellSouth local tandems; and (2) for local transit traffic transported by BellSouth for third party network providers who have also established an interconnection trunk group(s) at those BellSouth local tandems.

3.3.1.1 When a specified local calling area is served by more than one BellSouth local tandem, AT&T must designate a "home" local tandem for each of its assigned NPA/NXXs and establish trunk connections to such local tandems. Additionally, AT&T may choose to establish an interconnection trunk group(s) at the BellSouth local tandems where it has no codes homing but is not required to do so. AT&T may deliver local traffic to a "home" BellSouth local tandem that is destined for other BellSouth or third party network provider end offices subtending other BellSouth local tandems in the same local calling area where AT&T does not choose to establish an interconnection trunk group(s). It is AT&T's responsibility to enter its own NPA/NXX local tandem homing arrangements into the LERG either directly or via a vendor in order for other third party network providers to determine appropriate traffic routing to AT&T's codes. Likewise, AT&T shall obtain its routing information from the LERG.

3.3.1.2 Notwithstanding establishing interconnection trunk group(s) to BellSouth's local tandems, AT&T must also establish an interconnection trunk group(s) to BellSouth access tandems within the LATA on which AT&T has NPA/NXX's homed for the delivery of Interexchange Carrier Switched Access ("SWA") and toll traffic, and traffic to Type 2A CMRS connections located at the access tandems. BellSouth cannot switch SWA traffic through more than one BellSouth access tandem. SWA, Type 2A CMRS or toll traffic routed to the local tandem in error will not be backhauled to the BellSouth access tandem for completion. (Type 2A CMRS interconnection is defined in BellSouth's General Subscriber Services Tariff, Section A35.)

- 3.3.1.3 BellSouth shall pass transit traffic to other third party network providers subtending these local tandems. However, AT&T shall be responsible directly to that third party for all reciprocal compensation obligations.
- 3.3.2 BellSouth and AT&T, upon mutual agreement, shall establish interconnection trunk groups and trunking configurations between networks including the establishment of one-way or two-way trunks in accordance with Exhibits C-F of this Attachment 3, attached hereto and incorporated herein by this reference and pursuant to Section 3.16.
- 3.3.3 Except as otherwise provided in Section 1.9-1.9.2, all terms and conditions, as well as charges, both non-recurring and recurring, associated with interconnection trunk groups between BellSouth and AT&T not addressed in Exhibit A shall be as set forth in the appropriate Party's intrastate or interstate tariff for switched access services. For two-way trunking that carries the Parties' local and intraLATA toll traffic, excluding transit traffic, the Parties shall be compensated for the nonrecurring and recurring charges for trunks and DS1 facilities at 50% of the applicable contractual or tariff rates for the services provided by each Party. AT&T shall be responsible for ordering and paying for any two-way trunks carrying transit traffic.
- 3.4 All originating toll free service calls for which the end office Party performs the SSP function, if delivered to the tandem Party, shall be delivered by the end office Party using GR-394 CORE format for IXC bound calls, or using GR-317-CORE format for LEC bound calls.
- 3.5 Originating Feature Group B calls delivered to either Party's tandem shall use GR-317-CORE signaling format unless the associated FGB carrier employs GR-394-CORE signaling for its FGB traffic at the serving access tandem.
- 3.6 The Parties shall deliver over any trunk groups groomed for a specific access tandem only traffic destined for those publicly-dialable NPA NXX codes served by: (1) end offices that directly subtend the access tandem; and (2) those providers (including, but not limited to CMRS providers, other independent LECs, and CLECs) that directly connect to the access tandem.
- 3.7 For BellSouth end offices that do not normally subtend tandem for which calls are routed to that end office on an alternate routing basis, BellSouth will provide AT&T its alternative routing (scheme) arrangements. Where BellSouth utilizes alternative arrangements, it shall deliver any traffic through that alternative routing.

- 3.8 The Parties shall deliver over any trunk groups groomed for a specific end office only traffic destined for those publicly-dialable NPA NXX codes served by that end office, unless otherwise agreed to by the Parties.
- 3.9 The source for the routing information for all traffic shall be the LERG, unless otherwise agreed to between the Parties.
- 3.10 Where either Party delivers over the local traffic trunk groups miscellaneous calls (e.g., time, weather, 976) destined for the other Party, it shall deliver such traffic in accordance with the serving arrangements defined in the LERG.
- 3.11 The Parties will cooperate to establish separate, choke trunk groups for the completion of calls to customers such as radio contest lines. Notwithstanding the foregoing, the Parties agree that where the Parties' switch has the capability to perform call gapping and other protective network traffic management controls, separate trunk groups shall not be required to carry such traffic.
- 3.12 N11 code traffic shall be routed between the Parties' networks pursuant to accepted industry practice (e.g., over local traffic trunks or over separate trunk groups).
- 3.13 Each Party shall establish procedures whereby its operator bureau will coordinate with the operator bureau of the other Party in order to provide Busy Line Verification/Busy Line Verification Interrupt ("BLV/BLVI") services on calls between their respective line side end users for numbers that are not ported.
- 3.14 A blocking standard of one-half of one percent (.005) shall be maintained during the average busy hour for final trunk groups carrying jointly provided exchange access traffic between an end office and an access tandem. All other final trunk groups are to be engineered with a blocking standard of one percent (.01). High usage trunk groups shall be sized to an economic CCS parameter mutually agreed to by both Parties.
- 3.14.1.1 BellSouth agrees to provide upon request of AT&T, pursuant to Section 25 of the General Terms and Conditions of this Agreement, traffic usage data (including, but not limited to, usage, peg and overflow counts) for each AT&T NXX subtending the BellSouth tandem to determine which AT&T traffic by NXX is being blocked.
- 3.14.1.2 Pursuant to Attachment 9, incorporated herein by this reference, BellSouth shall report to AT&T information regarding blocking of interconnection traffic.

3.15 The Parties agree to jointly manage the capacity of interconnection trunk groups to encourage the economic deployment of increasingly robust and diverse interconnection between their networks.

3.16 BellSouth Access Tandem Interconnection Architectures

3.16.1 BellSouth Access Tandem Interconnection provides intratandem access to subtending end offices. AT&T may choose which type of trunking architecture to use from the trunking architectures described in this Attachment 3. However, if both Parties' originated local and/or intraLATA toll traffic is utilizing the same two-way trunk group, the Parties shall mutually agree to use this type of two-way interconnection trunk group with the quantity of trunks being mutually determined and the provisioning being jointly coordinated. Furthermore, the IP(s) for two-way interconnection trunk groups transporting both Parties local and/or intraLATA toll shall be mutually agreed upon. AT&T shall order such two-way trunks via the Access Service Request ("ASR") process in place for Local Interconnection upon determination by the Parties, in a joint planning meeting, that such trunk groups shall be utilized. BellSouth will use the Trunk Group Service Request ("TGSR") to request changes in trunking. Both Parties reserve the right to issue ASRs, if so required, in the normal course of business. Furthermore, the Parties shall jointly review such trunk performance and forecasts on a periodic basis. The Parties use of two-way interconnection trunk groups for the transport of local and/or intraLATA toll traffic between the Parties does not preclude either Party from establishing additional one-way interconnection trunks for the delivery of its originated local and/or intraLATA toll traffic to the other Party. Any AT&T interconnection request that deviates from the interconnection trunk group architectures as described in this Agreement that affects traffic delivered to AT&T from a BellSouth switch that requires special BellSouth switch translations and other network modifications will require AT&T to submit a Bona Fide Request/New Business Request ("BFR/NBR") via the BFR/NBR Process set forth in this Agreement.

3.17 Standard Trunking Interconnection

3.17.1 In this interconnection architecture AT&T's originating Local and IntraLATA Toll and originating and terminating Transit Traffic is transported on a single two-way trunk group between AT&T and BellSouth access tandem(s) within a LATA. This group carries intratandem Transit Traffic between AT&T and Independent Companies, Interexchange Carriers, other CLECs and other network providers with which AT&T desires interconnection and has the proper contractual arrangements. This group also carries AT&T originated intertandem traffic transiting a single BellSouth access tandem destined to third party tandems such as an Independent Company

tandem or other CLEC tandem. BellSouth originated Local and IntraLATA Toll traffic is transported on a single one-way trunk group terminating to AT&T. The Two-way Trunking Rules, described in this Agreement, do not apply to this architecture. Other trunk groups for operator services, directory assistance, emergency services and intercept may be established if requested by AT&T. The LERG should be referenced for current routing and tandem serving arrangements. The Preferred Trunking Interconnection architecture is illustrated in Exhibit C.

3.18 One Way Trunking Interconnection

3.18.1 In this arrangement, the Parties interconnect using two one-way trunk groups. One one-way trunk group carries AT&T-originated local and intraLATA toll traffic destined for BellSouth end-users. The other one-way trunk group carries BellSouth-originated local and intraLATA toll traffic destined for AT&T end-users. A third two-way trunk group is established for AT&T's originating and terminating Transit Traffic. This group carries intratandem Transit Traffic between AT&T and Independent Companies, Interexchange Carriers, other CLECs and other network providers with which AT&T desires interconnection and has the proper contractual arrangements. This group also carries AT&T originated intertandem traffic transiting a single BellSouth access tandem destined to third party tandems such as an Independent Company tandem or other CLEC tandem. Other trunk groups for operator services, directory assistance, emergency services and intercept may be established if requested by AT&T. The LERG should be referenced for current routing and tandem serving arrangements. One Way Trunking Interconnection is illustrated in Exhibit D.

3.19 Two-Way Trunking Interconnection

3.19.1 Two-Way Trunking Interconnection establishes one two-way trunk group to carry local and intraLATA toll traffic between AT&T and BellSouth. To establish this type of configuration, AT&T and BellSouth must agree to the Two-way Trunking Rules. In addition, a two-way transit trunk group must be established for AT&T's originating and terminating Transit Traffic. This group carries intratandem Transit Traffic between AT&T and Independent Companies, Interexchange Carriers, other CLECs and other network providers with which AT&T desires interconnection and has the proper contractual arrangements. This group also carries AT&T originated intertandem traffic transiting a single BellSouth access tandem destined to third party tandems such as an Independent Company tandem or other CLEC tandem. Other trunk groups for operator services, directory assistance, emergency services and intercept may be established if requested by AT&T. The

LERG should be referenced for current routing and tandem serving arrangements. Two-Way Trunk Interconnection is illustrated in Exhibit E.

3.20 Supergroup Interconnection

3.20.1 In the Supergroup Interconnection arrangement, the Parties Local and IntraLATA Toll and AT&T's Transit Traffic is exchanged on a single two-way trunk group between AT&T and BellSouth. AT&T and BellSouth must agree to the Two-way Trunking Rules in order to establish this architecture. This group carries intratandem Transit Traffic between AT&T and Independent Companies, Interexchange Carriers, other CLECs and other network providers with which AT&T desires interconnection and has the proper contractual arrangements. This group also carries AT&T originated intertandem traffic transiting a single BellSouth access tandem destined to third party tandems such as an Independent Company tandem or other CLEC tandem. Other trunk groups for operator services, directory assistance, emergency services and intercept may be established if requested. The LERG should be referenced for current routing and tandem serving arrangements. Supergroup Interconnection is illustrated in Exhibit F.

3.21 BellSouth End Office Interconnection

3.21.1 AT&T may establish interconnection at BellSouth end offices for the delivery of AT&T originated local and intralata toll traffic destined for BellSouth end-users served by that end-office.

3.21.2 When end office trunking is ordered by BellSouth to deliver BellSouth originated traffic to AT&T, BellSouth will provide overflow routing through BellSouth tandems consistent with how BellSouth overflows it's traffic. The overflow will be based on the homing arrangements AT&T displays in the LERG. Likewise, if AT&T interconnects to a BellSouth end office for delivery of AT&T originated traffic, AT&T will overflow the traffic through the BellSouth tandems based on the BellSouth homing arrangements shown in the LERG.

3.21.3 The Parties shall utilize direct end office-to-end office trunk groups under the following conditions:

3.21.3.1 Tandem Exhaust - If a tandem through which the Parties are interconnected is unable to, or is forecasted to be unable to support additional traffic loads for any period of time, the Parties will mutually agree on an end office trunking plan that will alleviate the tandem capacity shortage and ensure completion of traffic between AT&T and BellSouth's subscribers.

- 3.21.3.2 Traffic Volume –To the extent either Party has the capability to measure the amount of traffic between an AT&T switching center and a BellSouth end office, either Party shall install and retain direct end office trunking sufficient to handle actual or reasonably forecasted traffic volumes, whichever is greater, between an AT&T switching center and a BellSouth end office where the traffic exceeds or is forecasted to exceed a single DS1 of Local Traffic during the time consistent busy hour (as measured utilizing the day-to-day variation and peakedness) per month over a period of three (3) consecutive months. Either Party will install additional capacity between such points when overflow traffic between AT&T’s switching center and BellSouth’s end office exceeds or is forecasted to exceed a single DS1 of Local Traffic during the time consistent busy hour (measured utilizing the day-to-day variation and peakedness) per month. In the case of one way trunking, additional trunking shall only be required by the Party whose trunking has achieved the preceding usage threshold.
- 3.21.3.3 Mutual Agreement - The Parties may install direct end office trunking upon mutual agreement in the absence of conditions (1) or (2) above and agreement will not unreasonably be withheld.

4. **NETWORK DESIGN AND MANAGEMENT FOR INTERCONNECTION**

- 4.1 Network Management and Changes. Both Parties will work cooperatively with each other to install and maintain the most effective and reliable interconnected telecommunications networks, including but not limited to, the exchange of toll-free maintenance contact numbers and escalation procedures. Both Parties agree to provide public notice of changes in the information necessary for the transmission and routing of services using its local exchange facilities or networks, as well as of any other changes that would affect the interoperability of those facilities and networks.
- 4.2 Interconnection Technical Standards. The interconnection of all networks will be based upon accepted industry/national guidelines for transmission standards and traffic blocking criteria. Interconnecting facilities shall conform, at a minimum, to the technical specifications set forth in the applicable industry standard technical references. Signal transfer point, Signaling System 7 (“SS7”) connectivity is required at each interconnection point. BellSouth will provide out-of-band signaling using Common Channel Signaling Access Capability where technically and economically feasible, in accordance with the technical specifications set forth in the applicable industry standard technical references. Facilities of each Party shall provide the necessary on-hook, off-hook answer and disconnect supervision and

shall hand off calling number ID (Calling Party Number) when technically feasible.

- 4.3 Quality of Interconnection. The local interconnection for the transmission and routing of telephone exchange service and exchange access that each Party provides to each other will be at least equal in quality to what it provides to itself and any subsidiary or affiliate, where technically feasible, or to any other Party to which each Party provides local interconnection.
- 4.4 Common Channel Signaling. Both Parties will provide LEC-to-LEC Common Channel Signaling ("CCS") to each other, where available, in conjunction with all traffic in order to enable full interoperability of CLASS features and functions except for call return. All CCS signaling parameters will be provided, including automatic number identification ("ANI"), originating line information ("OLI") calling company category, charge number, etc. All privacy indicators will be honored, and each Party will cooperate with each other on the exchange of Transactional Capabilities Application Part ("TCAP") messages to facilitate full interoperability of CCS-based features between the respective networks. The Parties will provide all line information signaling parameters including, but not limited to, Calling Party Number, Charge Number (if it is different from calling party number), and originating line information ("OLI"). For terminating FGD, either Party will pass any CPN it receives from other carriers. All privacy indicators will be honored. Where available, network signaling information such as Transit Network Selection ("TNS") parameter (SS7 environment) will be provided by the end office Party wherever such information is needed for call routing or billing. Where TNS information has not been provided by the end office Party, the tandem Party will route originating exchange access traffic to the IXC using available translations. The Parties will follow all industry Ordering and Billing Forum ("OBF") adopted guidelines pertaining to TNS codes.
- 4.4.1 BellSouth's Common Channel Signaling Access Service ("CCSAS") allows interconnected carriers to exchange signaling information over a communications path that is separate from the message path.
- 4.4.2 The transport portion of CCSAS, commonly referred to as a signaling link, is provided via dedicated 56 kbps out of band signaling connections between the AT&T signaling point of interconnection and BellSouth's signaling point of interconnection ("SPOI").
- 4.4.3 The network termination point where this interconnection takes place is called the Signaling Transfer Point ("STP") port termination.

- 4.4.4 Charges for signaling links and the STP port termination can be found in Attachment 2 of this Agreement, incorporated herein by this reference.
- 4.4.5 Each CCSAS signaling connection provides for two-way digital transmission at speeds in multiples of 56 kbps. The connection to BellSouth's STP pair can be made from either AT&T's signaling point ("SP"), which requires a minimum of two links, or from AT&T's STP pair, which requires a minimum of four links.
- 4.5 SS7 Interconnection will take place at STP locations that are mutually agreed to by the Parties.
- 4.6 Where CCS is not available, in-band multi-frequency signaling will be provided. In such an arrangement, each Party will outpulse the full ten-digit telephone number of the called party to the other Party with appropriate call set-up and Automatic Number Identification ("ANI") where available, at parity.
- 4.7 The Parties will provide CCS to one another, where and as available, in conjunction with access to call related databases and Service Control Points ("SCP"), including toll free databases, Line Information Database ("LIDB"), Calling Name ("CNAM"), and any other necessary databases.
- 4.8 When the Parties establish new links, each Party shall provide its own STP port termination(s) and charge the other Party for the signaling links as follows
- 4.8.1 Where the SPOI for the signaling link is at a Fiber Meet, there shall be no compensation between the Parties for the signaling link facilities used.
- 4.8.2 Where the SPOI for the signaling link facilities is located at the BellSouth Serving Wire Center where the signaling link facilities terminates and AT&T has furnished the interconnection facility, BellSouth will pay a monthly charge equal to one half of the AT&T-provided facility charge according to BellSouth's unbundled rate element for the facility used. Rates for said interconnection facilities shall be as set forth in Exhibit A in Attachment 2, incorporated herein by this reference.
- 4.8.3 Where the SPOI for the signaling link facilities is located at the AT&T Serving Wire Center facility where the signaling link facilities terminate and BellSouth has furnished the interconnection facility, AT&T will pay a monthly charge equal to one half of the BellSouth-provided facility charge according to BellSouth's unbundled rate element for the facility

used. Rates for said interconnection facilities shall be as set forth in Exhibit A in Attachment 2, incorporated herein by this reference.

- 4.8.4 Each party is responsible for all facility maintenance and provisioning on its side of the SPOI.
- 4.9 Implementation of new interconnection arrangements (as opposed to augmentation of existing arrangements), including testing of SS7 interconnection, shall be pursuant to the technical specifications set forth in the applicable industry standard technical references. Each Party will be expected to provide sufficient cooperative testing resources to ensure proper provisioning, including the ability to confirm that AT&T LERG-assigned NPA NXX codes have been opened, translated and routed accurately in all appropriate BellSouth switches. A mutually agreed test calling plan shall be conducted to ensure successful completion of originating and terminating calls.
- 4.10 Message Screening
- 4.10.1 BellSouth shall set message screening parameters so as to accept messages from AT&T local or tandem switching systems destined to any signaling point in the BellSouth SS7 network or any network interconnected to the BellSouth SS7 network with which the AT&T switching system has a legitimate signaling relationship.
- 4.10.2 BellSouth shall set message screening parameters so as to accept messages destined to/from an AT&T local or tandem switching system or to/from an AT&T Service Control Point ("SCP") from any signaling point or network interconnected to the BellSouth SS7 network with which the AT&T switching system has a legitimate signaling relationship.
- 4.11 STP Requirements
- 4.11.1 BellSouth shall provide message transfer part and Signaling Connection Control Point ("SCCP") protocol interfaces in accordance with the technical specifications set forth in the applicable industry standard technical references.

- 4.12 SS7 Network Interconnection
- 4.12.1 SS7 Network Interconnection is the interconnection of AT&T STPs and AT&T local or tandem switching systems with the BellSouth STPs. This interconnection provides connectivity that enables the exchange of SS7 messages among BellSouth switching systems and databases, AT&T local or tandem switching systems and other third-party switching systems directly connected to the BellSouth SS7 network.
- 4.12.2 SS7 Network Interconnection shall provide connectivity to all components of the BellSouth SS7 network. These include:
- 4.12.2.1 BellSouth local or tandem switching systems;
- 4.12.2.2 BellSouth databases; and
- 4.12.2.3 Other third-party local or tandem switching systems.
- 4.12.3 The connectivity provided by SS7 Network Interconnection shall fully support the functions of BellSouth switching systems and databases and AT&T or other third-party switching systems with [note could be A or D/B link] direct access to the BellSouth SS7 network.
- 4.12.4 SS7 Network Interconnection shall provide transport for certain types of TCAP messages. If traffic is routed based on dialed or translated digits between an AT&T local switching system and a BellSouth or other third-party local switching system, either directly or via a BellSouth tandem switching system, then it is a requirement that the BellSouth SS7 network convey via SS7 Network Interconnection the TCAP messages that are necessary to provide Call Management services (Automatic Callback, Automatic Recall, and Screening List Editing) between the AT&T local STPs and the BellSouth or other third-party local switch.
- 4.12.5 When the capability to route messages based on Intermediate Signaling Network Identifier ("ISNI") is generally available on BellSouth STPs, the BellSouth SS7 Network shall also convey TCAP messages using SS7 Network Interconnection in similar circumstances where the BellSouth switch routes traffic based on a Carrier Identification Code ("CIC").
- 4.12.6 BellSouth shall offer the following SS7 Network Interconnection options to connect AT&T or AT&T-designated local or tandem switching systems or STPs to the BellSouth SS7 network:
- 4.12.6.1 A-link interface from AT&T local or tandem switching systems; and
- 4.12.6.2 D/B-link interface from AT&T STPs.

- 4.12.7 Each interface shall be provided by one or more sets (layers) of signaling links, as follows:
- 4.12.7.1 An A-link layer shall consist of two links.
- 4.12.7.2 A D/B-link layer shall consist of four links.
- 4.12.8 The Parties agree to implement intraoffice diversity for the signaling links so that no single failure of intraoffice facilities or equipment shall cause the failure of any two links in a layer connecting to a BellSouth STP.
- 4.12.9 Signaling Call Information. BellSouth and AT&T will send and receive 10 digits for local traffic. Additionally, BellSouth and AT&T will exchange the proper call information, i.e., originated call company number and destination call company number, CIC, and OZZ, including all proper translations for routing between networks and any information necessary for billing.
- 4.13 Trunk Forecasting and Servicing Requirements.
- 4.12.1 The Parties shall exchange technical descriptions and forecasts of their interconnection and traffic requirements in sufficient detail necessary to establish the interconnections required to assure traffic completion to and from all customers in their respective designated service areas. In order for BellSouth to provide as accurate reciprocal trunking forecasts as possible to AT&T, AT&T must timely inform BellSouth of any known or anticipated events that may affect BellSouth reciprocal trunking requirements. If AT&T refuses to provide such information, BellSouth shall provide reciprocal trunking forecasts based only on existing trunk group growth and BellSouth's annual estimated percentage of BellSouth subscriber line growth.
- 4.13.1 Both Parties shall meet every six months or at otherwise mutually agreeable intervals for the purpose of exchanging non-binding forecast of its traffic and volume requirements for the interconnection and network elements provided under this Agreement, in the form and in such detail as agreed by the Parties. The Parties agree that each forecast provided under this section shall be deemed "Confidential Information" as set forth in Section 18 of the General Terms and Conditions of this Agreement, incorporated herein by this reference.
- 4.13.2 The trunk forecast should include trunk requirements for all of the interconnection trunk groups for the current year plus the next two future years. The forecast meeting between the two companies may be a face-to-face meeting, video conference or audio conference. It may be held regionally or geographically. Ideally, these forecast meetings should be held at least semi-annually, or more often if the

forecast is no longer usable. Updates to a forecast or portions thereof should be made whenever the Party providing the forecast deems that the latest trunk requirements exceed the original quantities by 48 trunks or 10%, whichever is greater. Either Party should notify the other Party if they have measurements indicating that a trunk group is exceeding its designed call carrying capacity and is impacting other trunk groups in the network. Also, either Party should notify the other Party if they know of situations in which the traffic load is expected to increase significantly and thus affect the interconnection trunk requirements as well as the trunk requirements within the other Party's network. The Parties agree that the forecast information provided under this section shall be deemed "Confidential Information" as set forth in Section 18 of the General Terms and Conditions of this Agreement, incorporated herein by this reference. Each Party shall provide a specified point of contact for planning, forecasting and trunk servicing purposes.

- 4.13.3 For a non-binding trunk forecast, agreement between the two Parties on the trunk quantities and the timeframe of those trunks does not imply any liability for failure to perform if the trunks are not available for use at the required time.
- 4.13.4 Both Parties will manage the capacity of their interconnection trunk groups. BellSouth will issue an ASR to AT&T to order changes BellSouth desires to the BellSouth interconnection trunk groups based on BellSouth's capacity assessment. AT&T will issue an ASR to BellSouth to order changes AT&T desires to the AT&T interconnection trunk groups based on AT&T's capacity assessment.
 - 4.13.4.1 Either Party may issue a Trunk Group Service Request ("TGSR") to the other Party to order changes it desires to the interconnection trunk groups based on its capacity assessment. The Party receiving the TGSR will, within ten (10) business days, respond with an ASR or an explanation of why it believes an ASR is inappropriate.
 - 4.13.4.2 The Party submitting an ASR will provide complete and accurate tie down inventory assignments in typical industry bay, panel and jack format, or in such other format as the Parties agree, on each order by use of a Design Layout Record. Additional tie down information, such as span information, may be required when applicable.
 - 4.13.4.3 The Parties will prepare ASRs pursuant to the industry standard guidelines of the OBF. When submitting an ASR, BellSouth will identify AT&T's end office in the SEC LOC field of the ASR form.

- 4.13.4.4 The Party provisioning the ASR will assign to the requesting Party a location code expressed in CLLI code format that will appear in the Access Customer Terminal Location Field of the ASR.
- 4.13.5 The standard interval used for the provisioning of additions to local interconnection trunk groups shall be no greater than ten (10) business days, for orders of fewer than ninety-six (96) DS-0 trunks. Other orders shall be determined on an individual case basis. Where feasible, either Party will expedite installation, upon the other Party's request.
- 4.13.6 Major projects shall be limited to those projects that require the coordination and execution of multiple orders or related activities between and among BellSouth and AT&T work groups specifically relating to: (i) the initial establishment of local interconnection trunk groups; (ii) extending service into a new area; (iii) NXX code moves; (iv) facility grooming; or (v) network rearrangements. If orders that are component pieces of a major project are submitted after project implementation has been jointly planned and coordinated, they shall be submitted with a major project reference. Several orders submitted at one time may not be classified as a major project without the consent of the submitting Party. Each Party will identify a single point of contact who will be responsible for overall coordination and management of a major project through an agreed completion point.
- 4.13.7 As provided herein, AT&T and BellSouth agree to exchange escalation lists which reflect contact personnel including vice president level officers. These lists shall include name, department, title, phone number, and fax number for each person. AT&T and BellSouth agree to exchange an up-to-date list promptly following changes in personnel or information.
- 4.14 Interference or Impairment
- 4.14.1 Within three (3) business days of receipt of notification of blocking of traffic originated within the other Party's network, the Parties shall determine and begin work to implement reasonable corrective measures in a manner consistent with industry practices.
- 4.15 Local Dialing Parity
- 4.15.1 BellSouth and AT&T shall provide local and toll dialing parity to each other with no unreasonable dialing delays. Dialing parity shall be provided for all originating telecommunications services that require dialing to route a call. BellSouth and AT&T shall permit similarly situated telephone exchange service end users to dial the same number of digits to make a local telephone call notwithstanding the

identity of the end user's or the called party's telecommunications service provider.

5. NETWORK MAINTENANCE

5.1 Outage Repair Standard

5.1.1 In the event of an outage or trouble in any arrangement, facility, or service being provided by BellSouth hereunder, BellSouth will follow procedures for isolating and clearing the outage or trouble that are no less favorable than those that apply to comparable arrangements, facilities, or services being provided by BellSouth to itself, Affiliate or any other carrier whose network is connected to that of BellSouth.

5.2 BellSouth will use best efforts to provide AT&T with at least 30 days advance, written notice of scheduled maintenance activity. BellSouth may expedite or delay scheduled maintenance as a result of unscheduled maintenance or other unforeseen events. In those instances where BellSouth will not perform scheduled maintenance at the announced times, BellSouth will provide AT&T with as much notice as is reasonably possible concerning the changed schedule. For major, long term scheduled events, (i.e., switch software/processor updates or software upgrades/new releases to the Sonet transport network elements) BellSouth shall provide AT&T with as much advance, written notice as possible.

5.3 Interconnection Compensation

5.3.1 Compensation for Local Traffic

5.3.1.1 For the treatment of local and ISP-bound traffic in this Agreement, the Parties agree to implement the FCC's Order on Remand and Report and Order in CC Docket No. 96-98 and 99-68 released April 27, 2001 ("ISP Order on Remand"). The Parties further agree to amend this agreement, within sixty (60) days of execution, to incorporate language reflecting the FCC ISP Order on Remand. At such time as that amendment is finalized, the Parties agree to work cooperatively to "true-up" compensation amounts consistent with the terms of the amended language from the effective date of the FCC ISP Order on Remand to the date the amendment is finalized. The Parties do not agree on the rates to apply to ISP-bound traffic between the end of the term of the preceding Interconnection Agreement and June 14, 2001, the effective date of the FCC's ISP Order on Remand. In this Section, the Parties express their intent to file negotiated language to incorporate the FCC's ISP Order on Remand. If the Parties are unable to agree on this language addressing this issue by the time the language is due to be filed, the Parties will file their respective

proposed language with the appropriate Commission for resolution. Until final contract language is agreed upon or ordered, the Parties agree not to re-rate or bill each other for ISP-bound calls between the end of the term of the previous interconnection agreement and June 14, 2001. Additionally, the Parties agree to apply a "LATAwide" local concept to this Attachment 3, meaning that traffic that has traditionally been treated as intraLATA toll traffic will now be treated as local for intercarrier compensation purposes, except for those calls that are originated or terminated through switched access arrangements as established by the State Commission or FCC.

- 5.3.1.2 The Parties recognize and agree that the compensation for the transport and termination of Local Traffic is intended to allow each Party to recover costs associated with such traffic. The Parties recognize and agree that such compensation will not be billed and shall not be paid for calls where a Party sets up a call, or colludes with a third party to set up a call, to the other Party's network for the purpose of receiving reciprocal compensation, and not for the purposes of providing a telecommunications service to an end user.
- 5.3.2 The Parties shall provide for the mutual and reciprocal recovery of the costs for the network facilities utilized in transporting and terminating local traffic on each other's network. The Parties agree that charges for transport and termination of calls on their respective networks are as set forth in Exhibit A to this Attachment.
- 5.3.2.1 For the purposes of this Attachment 3, Common (Shared) Transport is defined as the transport of one Party's traffic by the other Party over the other Party's common (shared) facilities between the other Party's tandem switch and end office switch and/or between the other Party's tandem switches.
- 5.3.2.2 For the purposes of this Attachment 3, Tandem Switching is defined as the function that establishes a communications path between two switching offices through a third switching office (the Tandem switch). Pursuant to the Kentucky Public Service Commission's Order in Case No. 2000-465, BellSouth shall compensate AT&T for use of its switch at the tandem interconnection rate.
- 5.3.2.3 For the purposes of this Attachment 3, End Office Switching is defined as the function that establishes a communications path between the trunk side and line side of the End Office switch.
- 5.3.2.4 In the event that AT&T elects to offer service within a LATA using a switch located in another LATA, AT&T agrees to provide the transport for both Parties' traffic between the remote AT&T switch and a point (i.e., a facility point of presence) within the LATA in which AT&T offers

service. Such facility point of presence shall be deemed to be an AT&T switch for the purposes of this Attachment.

5.3.3 Switched Access Traffic. Switched Access Traffic is defined as telephone calls requiring local transmission or switching services for the purpose of the origination or termination of Intrastate InterLATA and Interstate InterLATA traffic. Switched Access Traffic includes, but is not limited to, the following types of traffic: Feature Group A, Feature Group B, Feature Group D, toll free access (e.g., 800/877/888), 900 access, and their successors. Additionally, If BellSouth or AT&T is the other Party's end user's presubscribed interexchange carrier or if an end user uses BellSouth or AT&T as an interexchange carrier on a 101XXXX basis, BellSouth or AT&T will charge the other Party the appropriate tariff charges for originating switched access services. The Parties have been unable to agree as to whether Voice over Internet Protocol ("VOIP") transmissions which cross local calling area boundaries constitute Switched Access Traffic. Notwithstanding the foregoing, and without waiving any rights with respect to either Party's position as to the jurisdictional nature of VOIP, the Parties agree to abide by any effective and applicable FCC rules and orders regarding the nature of such traffic and the compensation payable by the Parties for such traffic, if any; provided however, that any VOIP transmission which originates in one LATA and terminates in another LATA (i.e., the end-to-end points of the call), shall not be compensated as Local Traffic. This Section is interrelated to Section 5.3.1.1.

5.3.4 The Parties have been unable to agree as to the appropriate compensation for calls which originate in a LATA and terminate to a physical location outside of that LATA but to a number assigned to a rate center within that LATA. However, without prejudice to either Party's position concerning the application of reciprocal compensation or access charges to such traffic, the Parties agree for purposes of this Agreement only and subject to the Parties' agreement to the terms of Sections 5.3.1.1 and 5.3.3, and on an interim basis until the FCC issues an Order addressing this issue, neither Party shall bill the other reciprocal compensation, intercarrier compensation or switched access in connection with the exchange of any traffic as described in the first sentence of this paragraph. Once the FCC issues an Effective Order addressing this issue, the Parties agree to amend this Interconnection Agreement to comply with the Order on a prospective basis only within thirty (30) days of either Party's written request. No "true-up" shall be required in connection with such an Effective Order. Nothing in this Section 5.3.4 is intended to change the way that the Parties treat ISP-bound traffic in accordance with the FCC's ISP Order on Remand.

5.3.5 Billing Point of Interface Compensation. If BellSouth establishes a BPOI, AT&T agrees to pay to BellSouth Interoffice Dedicated

Transport and any associated Multiplexing for BellSouth to transport BellSouth's originated Local and ISP-bound Traffic over BellSouth facilities from the BPOI as described in Section 1.8.3 of this Attachment to the Physical Point of Interface. Such Interoffice Dedicated Transport shall be priced as set forth in Exhibit A. The Interoffice Dedicated Transport mileage shall be the airline mileage between the Vertical and Horizontal ("V&H") coordinates of the BPOI and the V&H coordinates of the BellSouth Point of Interface. The Interoffice Dedicated Transport charges for BPOI shall be billed based on the actual volume of traffic in increments of 8.9M minutes, which is a DS3 equivalent. BellSouth will not assess charges for an additional DS3 until the additional 8.9M-minute threshold is met.

- 5.3.6 Charges for Trunks and Associated Dedicated Facilities. Compensation for trunks and associated dedicated facilities shall be handled in accordance with Section 1.9-1.9.2 of this Attachment.
- 5.3.7 Percent Local Use. Each Party will report to the other a Percentage Local Usage ("PLU"). The application of the PLU will determine the amount of local minutes to be billed to the other Party. For purposes of developing the PLU, each Party shall consider every local call and every long distance call, excluding intermediary traffic. BellSouth shall report quarterly PLU factors to AT&T. BellSouth will accept from AT&T monthly PLU factors provided under the previous agreement until the third quarter of 2001, at which time AT&T shall report quarterly PLU factors. BellSouth and AT&T shall also provide a positive report updating the PLU. Detailed requirements associated with PLU reporting shall be as set forth in BellSouth's Standard Percent Local Use Reporting Platform for Interconnection Purchasers, as it is amended from time to time during this Agreement. Notwithstanding the foregoing, where the terminating company has message recording technology that identifies the traffic terminated, such information, in lieu of the PLU factor, shall at the company's option be utilized to determine the appropriate reciprocal compensation to be paid.
- 5.3.8 Percent Local Facility. Each Party shall report to the other a Percent Local Facility ("PLF"). The application of the PLF will determine the portion of switched dedicated transport to be billed per the local jurisdiction rates. The PLF shall be applied to multiplexing, local channel and interoffice channel switched dedicated transport utilized in the provision of local interconnection trunks. Each Party shall update its PLF on the first of January, April, July and October of the year and shall send it to the other Party to be received no later than thirty (30) calendar days after the first of each such month to be effective the first bill period the following month, respectively. Requirements associated with PLU and PLF calculation and reporting shall be as set forth in

BellSouth's Percent Local Use/Percent Local Facility Reporting Guidebook, as it is amended from time to time.

- 5.3.9 Percentage Interstate Usage. For combined interstate and intrastate AT&T traffic terminated by BellSouth over the same facilities, AT&T will be required to provide a projected Percentage Interstate Usage ("PIU") to BellSouth. All jurisdictional report requirements, rules and regulations for Interexchange Carriers specified in BellSouth's Intrastate Access Services Tariff will apply to AT&T. After interstate and intrastate traffic percentages have been determined by use of PIU procedures, the PLU factor will be used for application and billing of local interconnection. Notwithstanding the foregoing, where the terminating company has message recording technology that identifies the traffic terminated, such information, in lieu of the PLU factor, shall at the company's option be utilized to determine the appropriate reciprocal compensation to be paid.
- 5.3.10 Audits. On thirty (30) days' written notice, each Party must provide the other the ability and opportunity to conduct an annual audit of the traffic reported. BellSouth and AT&T shall retain records of call detail for a minimum of nine months from which a PLU and/or PIU can be ascertained. The audit shall be accomplished during normal business hours at an office designated by the Party being audited. Audit requests shall not be submitted more frequently than one (1) time per calendar year. Audits shall be performed by a mutually acceptable independent auditor paid for by the Party requesting the audit. The PLU and/or PIU shall be adjusted based upon the audit results and shall apply to the usage for the quarter the audit was completed, to the usage for the quarter prior to the completion of the audit, and to the usage for the two quarters following the completion of the audit. If, as a result of an audit, either Party is found to have overstated the PLU and/or PIU by twenty percentage points (20%) or more, that Party shall reimburse the auditing Party for the cost of the audit.
- 5.3.11 Compensation for 800 Traffic. Each Party shall compensate the other pursuant to the appropriate switched access charges, including the database query charge as set forth in the each Party's intrastate or interstate switched access tariffs.
- 5.3.12 Records for 8YY Billing. Each Party will provide to the other the appropriate records necessary for billing intraLATA 8YY customers. Records required for billing end users purchasing 8YY Services shall be provided pursuant to Attachment 6 of this Agreement, incorporated herein by this reference.

5.3.13 Transit Traffic Service. BellSouth shall provide tandem switching and transport services for AT&T's transit traffic. Transit traffic is traffic originating on AT&T's network that is switched and/or transported by BellSouth and delivered to a third party's network, or traffic originating on a third Party's network that is switched and/or transported by BellSouth and delivered to AT&T's network. Transit traffic consists of local transit traffic and Switched Access transit traffic. Rates for local transit traffic shall be the applicable call transport and termination charges as set forth in Exhibit A to this Attachment. Switched Access transit traffic shall be meet-point billed in accordance with the BellSouth Interstate or Intrastate Switched Access tariffs. Switched Access transit traffic presumes that AT&T's end office is subtending the BellSouth Access Tandem for switched access traffic to and from AT&T's end users utilizing BellSouth facilities, either by direct trunks with the IXC, or via the BellSouth Access Tandem. Billing associated with all transit traffic shall be pursuant to MECAB procedures. Wireless Type 1 traffic shall not be treated as transit traffic from a routing or billing perspective. Wireless Type 2A traffic shall not be treated as transit traffic from a routing or billing perspective until BellSouth and the Wireless carrier have the capability to properly meet-point-bill in accordance with Multiple Exchange Carrier Access Billing ("MECAB") guidelines. Transit traffic does not include traffic originating from or terminating to AT&T end-users utilizing resold BellSouth services.

LOCAL INTERCONNECTION
Kentucky

CATEGORY	NOTES	LOCAL INTERCONNECTION	File	Interim	Zone	BOS	USOC	RATES		OSS RATES										
								Rec	First	Nonrecurring Add1	First	Disconnect Add1	Source	Svc Order Submitted Elec per LSR	Svc Order Submitted Manually per LSR	Incremental Charge - Manual Svc Order vs. Electronic-1st	Incremental Charge - Manual Svc Order vs. Electronic-Add1	Incremental Charge - Manual Svc Order vs. Electronic-Disc 1st	Incremental Charge - Manual Svc Order vs. Electronic-Disc Add1	
LOCAL INTERCONNECTION (CALL TRANSPORT AND TERMINATION)	LEGEND: CA-COMMISSION APPROVED; CE-COMMISSION EFFECTIVE; CF-COMPLIANCE FILED; CS-COST STUDY; F-FILED.																			
END OFFICE SWITCHING		End Office Switching Function, Per MOU																		
TANDEM SWITCHING	* This charge is applicable only to transit traffic and is applied in addition to applicable switching and/or interconnection charges.	Tandem Switching Function Per MOU																		
		Multiple Tandem Switching per MOU (applies to Initial tandem only)																		
		Tandem Intermediary Charge, per MOU*																		
TRUNK CHARGE		Dedicated Tandem Trunk Port Service-per DS0**																		
		Installation Trunk Side Service - per DS0																		
		Dedicated End Office Trunk Port Service-per DS0**																		
		Dedicated End Office Trunk Port Service-per DS1**																		
		Dedicated Tandem Trunk Port Service-per DS0**																		
LOCAL INTERCONNECTION (TRANSPORT)		Dedicated Tandem Trunk Port Service-per DS1**																		
** This rate element is recovered on a per MOU basis and is included in the End Office Switching and Tandem Switching, per MOU rate elements																				
COMMON TRANSPORT (Shared)		Common Transport - Per Mile, Per MOU																		
		Common Transport - Facilities Termination Per MOU																		
INTEROFFICE CHANNEL - DEDICATED TRANSPORT - VOICE GRADE		Interoffice Channel - Dedicated Transport - 2-Wire Voice Grade - Per Mile per month																		
		Interoffice Channel - Dedicated Transport - 2-Wire Voice Grade - Facility Termination per month																		
INTEROFFICE CHANNEL - DEDICATED TRANSPORT - 56K4 KBPS		Interoffice Channel - Dedicated Transport - 56 kbps - per mile per month																		
		Interoffice Channel - Dedicated Transport - 56 kbps - Facility Termination per month																		
		Interoffice Channel - Dedicated Transport - 64 kbps - per mile per month																		
		Interoffice Channel - Dedicated Transport - 64 kbps - Facility Termination per month																		
INTEROFFICE CHANNEL - DEDICATED TRANSPORT - DS1		Interoffice Channel - Dedicated Channel - DS1 - Per Mile per month																		
		Interoffice Channel - Dedicated Transport - DS1 - Facility Termination per month																		
INTEROFFICE CHANNEL - DEDICATED TRANSPORT - DS3		Interoffice Channel - Dedicated Transport - DS3 - Per Mile per month																		
		Interoffice Channel - Dedicated Transport - DS3 - Facility Termination per month																		
LOCAL CHANNEL - DEDICATED TRANSPORT																				

LOCAL INTERCONNECTION
Kentucky

CATEGORY	NOTES	LOCAL INTERCONNECTION	File	Interim	Zone	BOS	USOC	RATES				OSS RATES								
								Rec	Nonrecurring		Source	Svc Order Submitted Elec per LSR SOMEC	Svc Order Submitted Manually per LSR SOMAN	Incremental Charge - Manual Svc Order vs. Electronic-1st SOMAN	Incremental Charge - Manual Svc Order vs. Electronic-Add1 SOMAN	Incremental Charge - Manual Svc Order vs. Electronic-Disc 1st SOMAN	Incremental Charge - Manual Svc Order vs. Electronic-Disc Add1 SOMAN			
									First	Add1								First	Add1	
		Local Channel - Dedicated - 2-Wire Voice Grade per month				OHL	TEFV2	\$18,189k		\$459,379k										
		Local Channel - Dedicated - 4-Wire Voice Grade per month				OHL	TEPV4	\$20,129k		\$461,189k										
		Local Channel - Dedicated - DS1 per month				OHI	TEFHG	\$44,639k		\$399,39k										
		Local Channel - Dedicated - DS3 Facility Termination per month (assumes 1 mile)				OH3	TEFHJ	\$595,59k		\$1141,549k										
		LOCAL INTERCONNECTION MID-SPAN MEET																		
		NOTE: If Access service ride Mid-Span Meet, one-half the tariffed service Local Channel rate is applicable																		
		Local Channel - Dedicated - DS1 per month				OH1WS	TEFHG	\$0.00		\$0.00										
		Local Channel - Dedicated - DS3 per month				OH3WS	TEFHJ	\$0.00		\$0.00										
		MULTIPLXERS																		
		Channelization - DS1 to DS0 Channel System				OH1	OH1N	\$139.85		\$103.14										
		DS3 to DS1 Channel System per month				OH3	SATNS	\$194.82		\$423.03										
		DS3 Interface Unit (DS1 COCI) per month				OH1	OH1WS	\$14.43		\$13.16										
		Notes: If no rate is identified in the contract, the rate for the specific service or function will be as set forth in applicable BellSouth tariff or as regulated by the Parties upon request by either Party. "BK" by a rate element indicates that the element is or is not subject to bill and keep as described in Sections 1.9 - 1.9.2 of Attachment 3.																		

EXHIBIT B: SPACE LICENSE

1. AT&T, at its sole discretion, may license BellSouth to situate BellSouth equipment in the AT&T central office and to utilize AT&T site support services in the AT&T central office such as power, heating, ventilation, air conditioning and security for such equipment, for the sole purpose of interconnection. Such licenses and site support services are referred to herein collectively as a "Space License." If AT&T denies BellSouth a Space License in a particular AT&T central office, AT&T shall assure that BellSouth may interconnect with AT&T's network through an alternative arrangement reasonably acceptable to both parties, including without limitation, lease of AT&T's facilities directly connected to BellSouth's network; mid-span fiber meet; space in an adjacent premises; and an arrangement by which AT&T would assume ownership and control of equipment provided by BellSouth to be located in the AT&T central office for the sole purpose of interconnection.
2. The allowable network interfaces under a Space License are DS1, DS3 or another network interface as mutually agreed upon between the Parties to this Agreement.
3. Space Licenses are available subject to the availability of space and site support services in each AT&T central office. To establish a Space License, BellSouth must complete and submit a questionnaire providing requested information to support new space and site support services or to provide additional capacity for existing arrangements.
 - 3.1 Among the information to be provided in the questionnaire, BellSouth must identify the quantity, manufacturer, type and model of any equipment to be installed; the quantity, type and specifications of any transmission cable to be installed (collectively "Licensed Facilities"). The space in the AT&T central office in which BellSouth's equipment is or is to be located is referred to herein as the "Equipment Space."
 - 3.2 BellSouth is responsible for the installation of Licensed Facilities in accordance with AT&T's installation processes and procedures. BellSouth will use AT&T's certified vendors for the installation of License Facilities.
 - 3.3 If BellSouth desires to modify its request, prior to notification from AT&T regarding availability, BellSouth may do so by requesting that AT&T cancel the original request providing a new questionnaire to AT&T to process.

4. Following receipt of the questionnaire, AT&T will determine whether there is sufficient AT&T central office space and site support services to meet the request contained in BellSouth's questionnaire. AT&T will notify BellSouth in writing within thirty (30) business days whether there is sufficient AT&T central office space available for each such request.
5. Upon receiving written notification of the availability of AT&T central office space from AT&T, BellSouth will provide written verification that it still requires such AT&T central office space. This written notification is BellSouth's firm order for each AT&T central office space requested, and will constitute an executed Space License under the terms of this Exhibit B.
6. The rates and charges are to be negotiated by the Parties.
7. AT&T agrees to provide site support services as follows:
 - 7.1 AT&T will design, engineer, furnish, install, and maintain cable racks for BellSouth's use.
 - 7.2 AT&T will design, engineer, furnish, install, and maintain a battery distribution fuse board ("BDFB") from which AT&T will supply DC power to BellSouth.
 - 7.3 AT&T will provide common use convenience outlets (120V) as required for test equipment, etc. within Equipment Space.
 - 7.4 AT&T will maintain temperature and humidity conditions for the Equipment Space within substantially the same ranges that AT&T maintains for its own similar equipment.
8. AT&T will provide the amount of space requested by BellSouth unless AT&T reasonably determines the quantity of space requested is not available. If the amount of requested space is not available, AT&T will specify the dimensions of the Equipment Space available and will specify any physical or space separation requirements. If the amount of space requested is available, AT&T will provide the location of the space and will specify any physical or space separation requirements.
9. For the purpose of performing work for which BellSouth is responsible under this Exhibit B, AT&T licenses BellSouth to enter and exit the Equipment Space through portions of the AT&T central office as designated by AT&T. Unless a service outage is occurring or appears to be imminent, BellSouth shall perform its work in the AT&T central

office during regular business hours as designated from time to time by AT&T. BellSouth and AT&T will establish contact lists and procedures for after hours entry to the AT&T central office.

10. BellSouth will provide a twenty-four (24) hour local or toll free telephone number which AT&T can use to verify the authority of such personnel to enter the Equipment Space. BellSouth shall furnish to AT&T, and keep current, samples of the identifying credentials to be carried by all BellSouth employees authorized to enter the Equipment Space. Notwithstanding Section 10 of the General Terms and Conditions of this Agreement, incorporated herein by this reference, or except in the case of willful misconduct or gross negligence on the part of AT&T, BellSouth hereby releases AT&T, AT&T's Affiliates and their officers, directors, employees, agents, contractors, and suppliers from liabilities arising from the acts or omissions of any person who possesses a BellSouth employee identification badge and who was verified and admitted by AT&T.
11. While in the AT&T central office, employees of BellSouth and its contractors must comply at all times with AT&T's security and safety procedures and requirements. AT&T may refuse entry to, or require the departure of, any person who is disorderly or who has failed to comply with AT&T's procedures and requirements after being notified of them.
12. Each Party shall cause its employees and contractors to act in a careful and workmanlike manner to avoid damage to the other Party's property and the property of others in and around AT&T's central office.
13. BellSouth's employees and contractors shall abide by the requirements of Section 5.10, Interference or Impairment, of Attachment 4, incorporated herein by this reference.
14. In addition to the Licensed Facilities, BellSouth may bring into the Equipment Space whatever tools and equipment necessary to install and maintain its equipment. BellSouth will be responsible for the care and safeguarding of all such items. BellSouth may not bring into the AT&T central office any of the following: wet cell batteries, explosives, flammable liquids or gases, alcohol, controlled substances, weapons, cameras, tape recorders, and similar items.
15. AT&T and its designees may inspect or observe the Equipment Space, the space designated by AT&T for BellSouth transmission cable, the Licensed Facilities, and any work performed by or behalf of

BellSouth in the AT&T central office, at any time. If the Equipment Space is surrounded by a security enclosure, BellSouth shall furnish AT&T with all mechanisms and information needed for entry to the Equipment Space.

16. AT&T and BellSouth intend that the Licensed Facilities, whether or not physically affixed to the AT&T central office, shall not be construed to be fixtures. BellSouth (or the lessor of BellSouth equipment, if applicable) will report the Licensed Facilities as its personal property wherever required by applicable laws, and will pay all taxes levied upon the Licensed Facilities.
17. BellSouth agrees not to sell, convey, or lease BellSouth transmission cable under any circumstances, except for a conveyance of BellSouth transmission cable to AT&T or to another space licensee upon termination of the applicable Space License. BellSouth further agrees not to cause, suffer, or permit BellSouth transmission cable to become encumbered by a lien, trust, pledge, or security interest as a result of rights granted by BellSouth or any act or omission of BellSouth. If BellSouth transmission cable becomes so encumbered, BellSouth agrees to discharge the obligation within thirty (30) days after receiving notice of the encumbrance.
18. The licenses granted by this Agreement are non-exclusive personal privileges allowing BellSouth to situate the Licensed Facilities in the locations indicated by AT&T. These licenses and the payments by BellSouth under this Agreement do not create or vest in BellSouth (or in any other person) any property right or interest of any nature in any part of the AT&T central office.
19. The licenses granted to BellSouth under this Agreement shall be subordinate to any mortgages or deeds of trust that may now exist or may in the future be placed upon any AT&T central office; to any and all advances to be made under such mortgages or deeds of trust; and to the interest thereon and all renewals, replacements, or extensions thereof.
20. AT&T may relocate the licensed space, or the AT&T central office, or both upon thirty (30) days prior written notice to BellSouth. If relocation of Licensed Facilities is required, the party that originally installed such Licensed Facilities will be responsible for relocating them. Any such relocation work that is AT&T's responsibility and is performed by AT&T will be without charge to BellSouth. AT&T will reimburse BellSouth for the reasonable cost of such relocation work performed by BellSouth, and AT&T will provide at its own expense any

additional or replacement cable racks and BellSouth transmission cable needed to accommodate the relocation of the installation. AT&T and BellSouth will work together in good faith to minimize any disruption of service in connection with such relocation.

21. Licensed Facilities will be furnished, installed and maintained in accordance with the following:
 - 22.1 BellSouth agrees to furnish all Licensed Facilities.
 - 22.2 BellSouth agrees to install the Licensed Facilities. BellSouth agrees to comply with specifications and processes furnished by AT&T for installation performed by BellSouth.
 - 22.3 BellSouth agrees to install the DC power supply and single circuit (battery and ground) from its fuse panel located in BellSouth's frame to the designated AT&T power source. BellSouth will distribute the power among its equipment within the Equipment Space.
 - 22.4 BellSouth agrees to maintain in good working order all BellSouth equipment in Equipment Space. AT&T agrees to repair BellSouth transmission cable. BellSouth is not permitted to repair installed BellSouth transmission cable in order to avoid possible harm to other transmission cables.
 - 22.5 BellSouth may use contractors to perform installation and maintenance for which BellSouth is responsible. AT&T consents to use of those contractors listed on a then current AT&T approved list of BellSouth submitted contractors. Use of any other contractors shall require AT&T's prior written consent, which shall not be unreasonably withheld.
 - 22.6 BellSouth may, at its own discretion and expense, choose to install its equipment in locked cabinets, provided that space and configuration will permit such. If BellSouth chooses to install its equipment in locked cabinets, BellSouth shall leave the appropriate keys with AT&T and agrees to allow AT&T the right of entry to such cabinets.
22. Under the Space Licenses, AT&T performs no communications services, provides no goods except for short lengths of wire or cable and small parts incidental to the services furnished by AT&T, and provides no maintenance for any BellSouth equipment in Equipment Space. AT&T warrants that the services provided under this Agreement will be performed in a workmanlike manner and in accordance with AT&T technical specifications and that the incidental

material provided by AT&T shall be free from defects. AT&T MAKES NO OTHER WARRANTIES, EXPRESS OR IMPLIED, AND SPECIFICALLY DISCLAIMS ANY WARRANTIES OF MERCHANTABILITY OR FITNESS FOR A PARTICULAR PURPOSE.

23. In addition to any other rights or remedies that AT&T may have under this Agreement or at law, AT&T may terminate the applicable Space License if any of the following events occurs and is not corrected within thirty (30) days after written notice to cure:
- 24.1 BellSouth fails to pay charges due or fails to comply with any of the terms or conditions of this Exhibit B.
- 24.2 BellSouth fails to comply with applicable laws or is in any way prevented by the order or action of any court, or other governmental entity from performing any of its obligations under this Exhibit B.
24. In the event that a Space License is terminated for any reason, the Parties will act in accordance with the following:
- 25.1 Within thirty (30) days after termination of a Space License, BellSouth will, at its sole expense, remove all BellSouth equipment in Equipment Space and restore the Equipment Space to its previous condition, normal wear and tear excepted. If BellSouth fails to complete such removal and restoration within thirty (30) days after termination of the applicable Space License, AT&T may, at its option, upon ten (10) days written notice to BellSouth, perform the removal and restoration at BellSouth's sole risk and expense.
- 25.2 Because removal of installed BellSouth transmission cable may cause damage to other cables or fiber, BellSouth agrees to relinquish or transfer its transmission cable to AT&T or to another AT&T space licensee in lieu of removal. Upon termination of the applicable Space License, unless transferred to another AT&T space licensee, all BellSouth transmission cable will be automatically conveyed to AT&T, thereby becoming the property of AT&T, free of any interest or lien of any kind by BellSouth (or by any person claiming through BellSouth). At AT&T's request, BellSouth will promptly execute and deliver to AT&T a bill of conveyance or such other assurances as may be requisite to confirm or perfect the transfer of BellSouth transmission cable to AT&T.
- 25.3 If no monies are owed by BellSouth to AT&T under this Agreement, AT&T agrees to deliver such removed equipment to BellSouth's last known business address or to a domestic location designated by

BellSouth, at BellSouth's sole risk and expense.

Preferred Interconnection Architecture

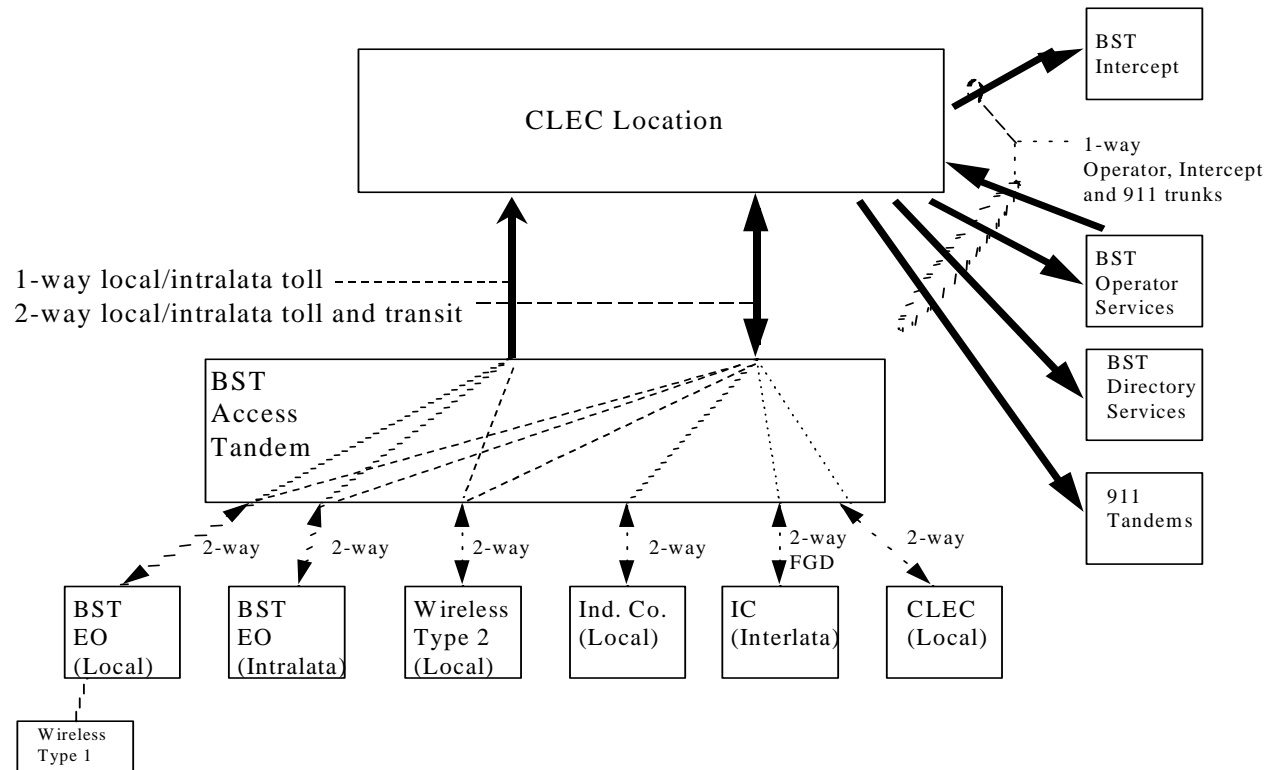

Exhibit C

One Way Trunking Interconnection

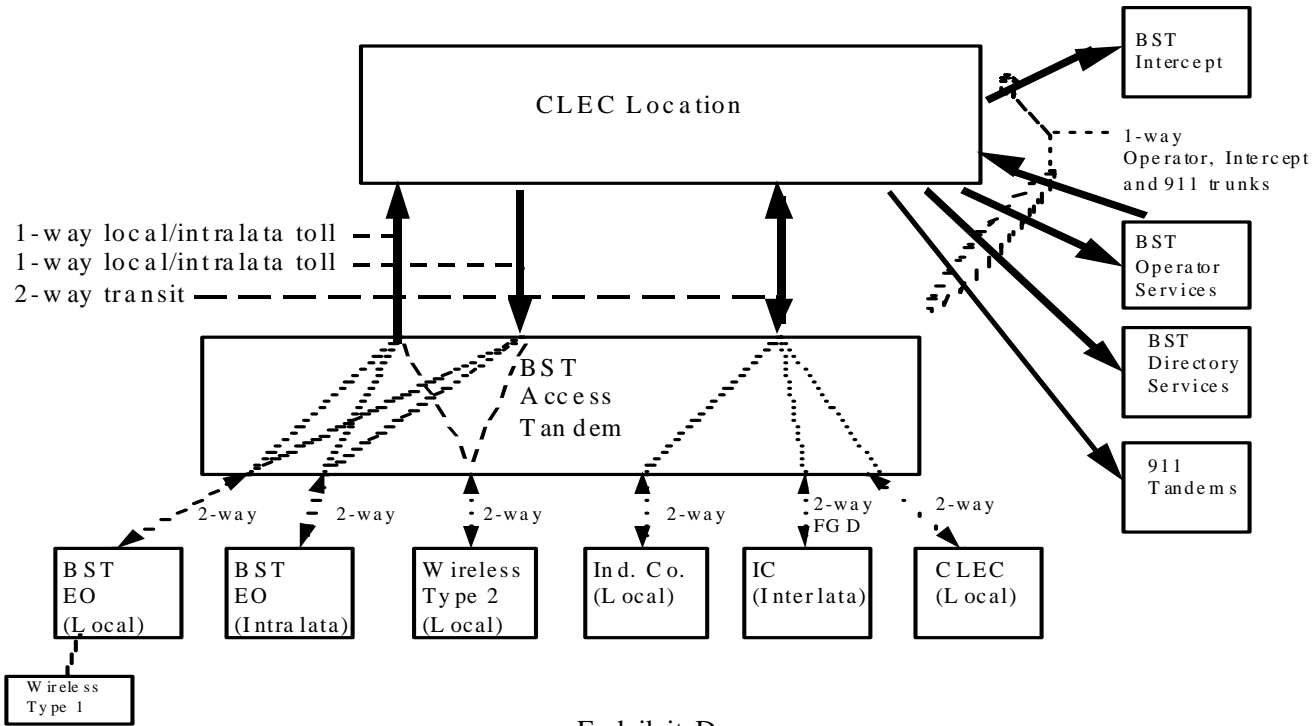

Exhibit D

Two Way Trunking Interconnection

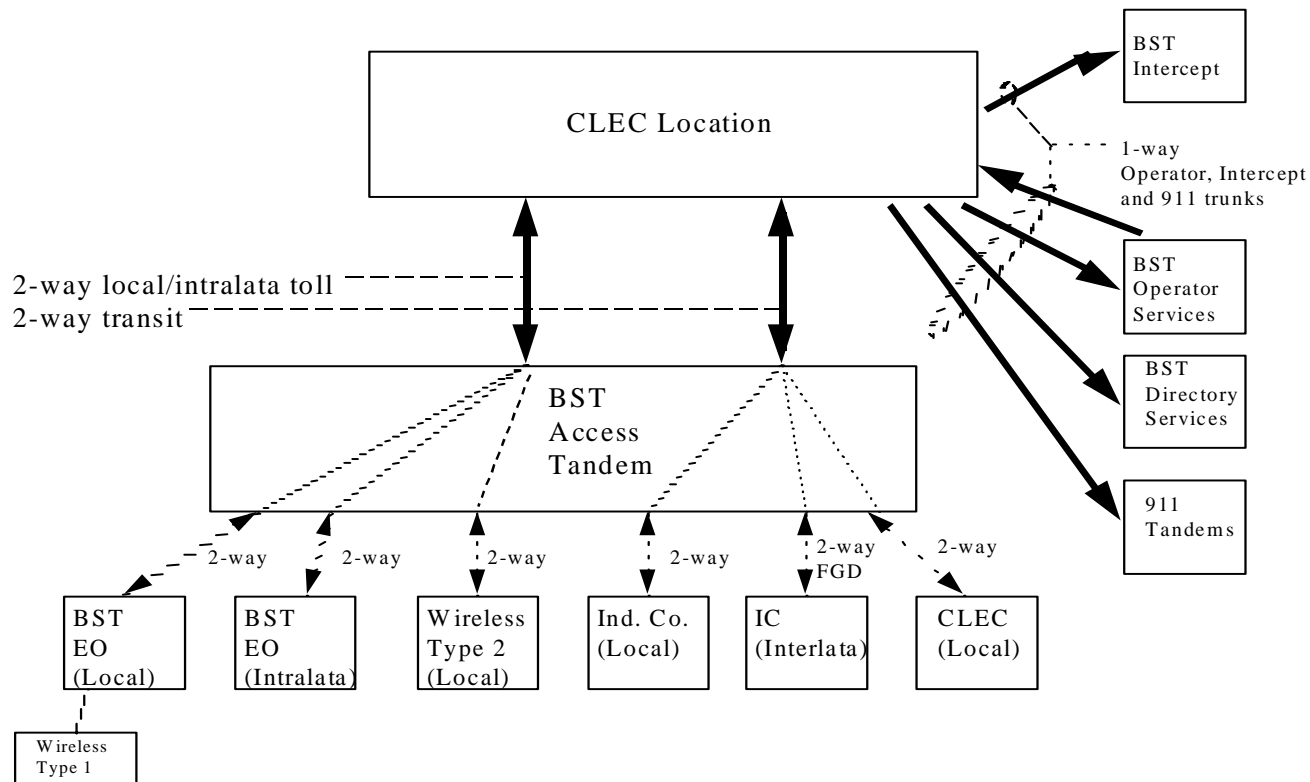

Exhibit E

SuperGroup Interconnection Architecture

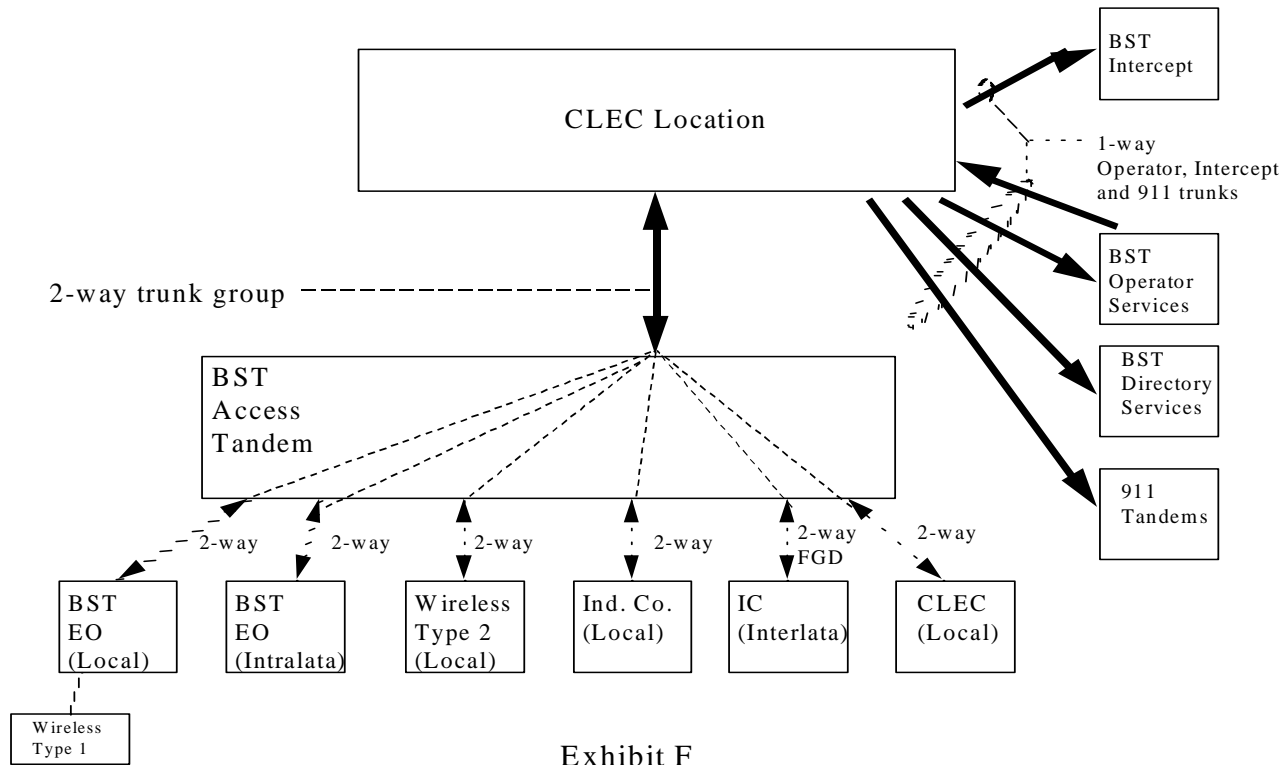

Exhibit F

Attachment 4

Collocation

TABLE OF CONTENTS

- 1. SCOPE OF ATTACHMENT 3
- 2. SPACE NOTIFICATION 4
- 3. COLLOCATION OPTIONS 6
- 4. OCCUPANCY 10
- 5. USE OF COLLOCATION SPACE..... 12
- 6. ORDERING AND PREPARATION OF COLLOCATION SPACE..... 18
- 7. RATES AND CHARGES..... 24
- 8. INSURANCE 26
- 9. MECHANICS LIENS 26
- 10. INSPECTIONS..... 27
- 11. SECURITY AND SAFETY REQUIREMENTS..... 27
- 12. NOTIFICATION OF SERVICE AFFECTING ACTIVITY WITHIN THE
BELLSOUTH PREMISES 31
- 13. DESTRUCTION OF COLLOCATION SPACE 31
- 14. EMINENT DOMAIN 32
- 15. RELOCATION OF AT&T’S EQUIPMENT 32
- 16. NONEXCLUSIVITY..... 33

EXHIBIT A, ENVIRONMENTAL AND SAFETY PRINCIPLES

Exhibit B-CLEC Forecast Form

Exhibit C-Rates

COLLOCATION

1. SCOPE OF ATTACHMENT

- 1.1 Scope of Attachment. BellSouth shall offer to AT&T collocation on rates, terms and conditions that are just, reasonable, nondiscriminatory and consistent with the rules and regulations of the FCC. If BellSouth provides any collocation to its own customers, to a BellSouth affiliate or to any other entity, BellSouth will provide the same collocation to AT&T at rates, terms and conditions no less favorable to AT&T than those provided by BellSouth to itself or to any other party. The rates, terms, and conditions contained within this Attachment shall only apply when AT&T is occupying the collocation space as a sole occupant or as a Host, as defined below, pursuant to Section 3 of this Attachment 4.
- 1.1.1 The Parties agree that for the purposes of this Attachment 4, "Day" means calendar day, unless otherwise specifically noted.
- 1.2 Right to occupy. Subject to Section 4 of this Attachment 4, BellSouth hereby grants to AT&T a right to occupy that certain area designated by BellSouth within a BellSouth Premises, of a size which is specified by AT&T and agreed to by BellSouth (hereinafter "Collocation Space"). "Premises" refers to BellSouth's central offices and serving wire centers, as well as all buildings or similar structures owned, or leased, or otherwise controlled by BellSouth that house its network facilities, and all structures that house BellSouth's facilities on public rights-of-way, including but not limited to vaults containing loop concentrators or similar structures; and all land owned, leased, or otherwise controlled by BellSouth that is adjacent to these central offices, wire centers, buildings, and structures. To the extent this Agreement does not include all the necessary rates, terms and conditions for BellSouth Premises other than BellSouth central offices, the Parties will negotiate said rates, terms and conditions at the request for collocation at other than a central office. Notwithstanding the foregoing, BellSouth shall consider in its designation for cageless collocation any unused space within the BellSouth Premises. The size specified by AT&T may contemplate a request for space sufficient to accommodate AT&T's growth within a two year period unless otherwise agreed to by the Parties.
- 1.2.1 Space Reclamation. In the event of space exhaust within a Premise, BellSouth may provide notice, which must be in writing, to AT&T requesting that AT&T release non-utilized Collocation Space to BellSouth to be allocated to other physical collocation applicants when

100% of the space in AT&T's collocation arrangement is not being utilized by the end of the second year from the date AT&T accepted the Collocation Space. AT&T, within twenty (20) days of receipt of a written notification from BellSouth, shall either: (i) return the non-utilized Collocation Space to BellSouth, in which case AT&T shall be relieved of all obligation for charges for that portion of the Collocation Space so released; (ii) provide BellSouth evidence that equipment is on order which will be installed in the non-utilized Collocation Space; or (iii) enter into a sharing relationship with another telecommunications carrier who will utilize the non-utilized Collocation Space.

- 1.3 Use of Space. AT&T shall use the Collocation Space for the purposes of installing, provisioning, maintaining and operating AT&T's equipment (to include testing and monitoring equipment) necessary primarily to gain access to Network Elements and Combinations and secondarily to interconnect with BellSouth services and facilities, for the provision of telecommunications services. Pursuant to Section 5 of this Attachment 4, AT&T may at its option, place AT&T-owned or AT&T-leased entrance facilities to the Collocation Space. The Collocation Space may be used for no other purposes except as specifically described herein or authorized in writing by BellSouth.
- 1.4 BellSouth will offer virtual or adjacent, where technically feasible, collocation of the equipment where BellSouth is prepared to demonstrate that physical collocation is not practical for technical reasons or because of space limitations as provided in § 251(c)(6) of the Act and FCC orders.
- 1.5 Rates and charges. AT&T agrees to pay the rates and charges identified at Exhibit C attached hereto.
- 1.6 Due Dates. If any due date contained in this Attachment falls on a weekend or National holiday, then the due date will be the next business day thereafter.

2. SPACE NOTIFICATION

- 2.1 Availability of Space. Upon submission of an application pursuant to Section 6 of this Attachment 4, BellSouth will permit AT&T to physically collocate, pursuant to the terms of this Attachment, at any BellSouth Premises, unless BellSouth has determined that there is no space available due to space limitations or no space available due to technical infeasibility. BellSouth will respond to an application within ten (10) calendar days as to whether space is available or not

available within a BellSouth Premises. If BellSouth responds that requested space is not available within the requested BellSouth Premises, BellSouth will inform AT&T of the amount of space that is available. If no space is available, BellSouth will inform AT&T that virtual or adjacent collocation is an option at the requested Premises.

- 2.2 Reporting. Upon request from AT&T, BellSouth will provide a written report specifying the amount of collocation space available at the Premises requested, the number of collocators present at the Premises, any modifications in the use of the space since the last report or the Premises requested and the measures BellSouth is taking to make additional space available for collocation arrangements.
- 2.2.1 The request from AT&T must be written and must include the Premises and Common Language Location Identification (“CLLI”) code of the Premises where applicable. Such information regarding Premises and CLLI code is located in the National Exchange Carriers Association (“NECA”) Tariff FCC No. 4.
- 2.2.2 BellSouth will respond to a request for a particular Premises within ten (10) calendar days of receipt of such request. BellSouth will respond in ten (10) calendar days to a request for up to and including five (5) Premises within the same state. The response time for a request of more than five (5) Premises shall be negotiated between the Parties. If BellSouth cannot meet the ten (10) calendar-day response time, BellSouth shall notify AT&T and inform AT&T of the time frame under which it can respond.
- 2.3 Denial of Application. After notifying AT&T that BellSouth has no available space in the requested Premises (“Denial of Application”), BellSouth will allow AT&T, upon request, to tour the entire Premises within ten (10) calendar days of such Denial of Application. In order to schedule said tour within ten (10) calendar days, the request for a tour of the central office must be received by BellSouth within five (5) calendar days of the Denial of Application. Notwithstanding the foregoing, the Parties may agree to conduct the tour outside of the 10-day period.
- 2.4 Filing of Petition for Waiver. Upon Denial of Application BellSouth will timely file a petition with the Commission pursuant to 47 U.S.C. § 251(c)(6) and the appropriate state and federal rules and regulations.
- 2.5 Waiting List. On a first come first served basis, BellSouth will maintain a waiting list of requesting carriers who have either received a Denial

of Application or, where it is publicly known that the Premises is out of space, have submitted a letter of intent to collocate. BellSouth will notify the telecommunications carriers on the waiting list when space becomes available according to how much space becomes available and the position of the telecommunications carrier on said waiting list. Upon request BellSouth will advise AT&T as to its position on the list.

- 2.6 Public Notification. BellSouth will maintain on its Interconnection Services website a notification document that will indicate all Premises that are without available space. BellSouth shall update such document within ten (10) calendar days of the Denial of Application date. BellSouth will also post a document on its Interconnection Services website that contains a general notice where space has become available in a central office previously on the space exhaust list. BellSouth shall allocate said available space pursuant to the waiting list referenced in Section 2.5 of this Attachment 4.

3. COLLOCATION OPTIONS

- 3.1 Cageless. Except where local building code does not allow cageless collocation, BellSouth shall allow AT&T to collocate AT&T's equipment and facilities without requiring the construction of a cage or similar structure to enclose said equipment and without requiring the creation of a separate entrance to the Collocation Space. BellSouth shall allow AT&T to have direct access to its equipment and facilities but may require AT&T to use a central entrance to the BellSouth Premises. BellSouth shall make cageless collocation available in single bay increments pursuant to Section 7.4 of this Attachment 4. BellSouth shall assign cageless Collocation Space in conventional equipment rack lineups where feasible. For equipment requiring special technical considerations, AT&T must provide the equipment layout, including spatial dimensions for such equipment pursuant to Section 5.1.1 of this Attachment 4 and shall be responsible for constructing all special technical requirements associated with such equipment pursuant to Section 6.5 of this Attachment 4.

- 3.1.1 Shared Cageless Collocation. AT&T may allow other telecommunications carriers to share AT&T's cageless collocation arrangements pursuant to the terms and conditions of Section 3.1.1 and Section 3.3 of this Attachment. Notwithstanding the forgoing, sharing of cageless space within the cageless arrangement shall not be authorized (1) where local building codes do not allow shared cageless collocation; or (2) where the BellSouth Premises is located within a leased space and BellSouth is prohibited by that lease from offering shared cageless collocation or (3) where the only remaining

space of AT&T's cageless collocation arrangement requires AT&T's equipment to be commingled with BellSouth equipment. For purposes of this section, commingled means that the location of the AT&T cageless arrangement in the BellSouth equipment lineup is such that BellSouth is not able to enclose BellSouth's equipment. AT&T shall coordinate with its Guest, as defined below, and BellSouth to limit the number of parties working within the shared cageless collocation arrangement at the same time. BellSouth agrees to waive this provision in the event a specific project requires the presence of multiple parties all at the same time.

- 3.2 Cages and Adjacent Arrangement Enclosures. At AT&T's option and upon request, BellSouth shall construct cages in compliance with AT&T's collocation request. At AT&T's request, BellSouth shall permit AT&T to subcontract the construction of physical collocation arrangements with BellSouth Certified Vendors, provided however, that BellSouth shall not unreasonably withhold approval of contractors.
- 3.2.1 When AT&T subcontracts the construction, AT&T must arrange with a BellSouth Certified Vendor to construct a collocation arrangement enclosure in accordance with BellSouth's guidelines and specifications and at AT&T's expense. BellSouth will provide guidelines and specifications upon request. Where local building codes require enclosure specifications more stringent than BellSouth's standard enclosure specification, AT&T and AT&T's BellSouth Certified Vendor must comply with local building code requirements. AT&T's BellSouth Certified Vendor shall be responsible for filing and receiving any and all necessary permits and/or licenses for such construction. BellSouth shall cooperate with AT&T and provide, at AT&T's expense, the documentation, including architectural drawings, necessary for AT&T to obtain the zoning, permits and/or other licenses. BellSouth shall pass on to AT&T the costs of providing the documentation. The Certified Vendor shall bill AT&T directly for all work performed for AT&T pursuant to this Attachment and BellSouth shall have no liability for nor responsibility to pay such charges invoiced by the Certified Vendor.
- 3.2.2 BellSouth has the right to inspect the enclosure after construction to make sure it is designed and constructed according to BellSouth's specifications and to require AT&T to remove or correct at AT&T's cost any structure that does not meet these standards.
- 3.2.3 AT&T must provide the local BellSouth building_contact with two Access Keys used to enter the locked enclosure. Access Keys provided to BellSouth shall not be duplicated under any circumstances. Except in case of emergency, BellSouth will not

access AT&T's locked enclosure prior to notifying AT&T. BellSouth shall notify AT&T in writing immediately in the case of lost or stolen Access Keys. BellSouth will reimburse AT&T the reasonable costs to replace each Access Key lost or stolen. Should it become necessary for AT&T to re-key locked enclosures as a result of a lost Access Key(s) or for failure to return an Access Key(s), BellSouth shall pay for all reasonable costs associated with the re-keying. AT&T shall have the right, at its expense, to have locks changed where deemed necessary for the protection and security of its locked enclosures, provided that AT&T shall immediately provide BellSouth with such new keys.

- 3.3 Shared Caged Collocation. AT&T may allow other telecommunications carriers to share AT&T's caged collocation arrangement pursuant to terms and conditions agreed to by AT&T ("Host") and other telecommunications carriers ("Guests") and pursuant to this section with the following exceptions: (1) where local building code does not allow Shared Caged Collocation and (2) where the BellSouth Premises is located within a leased space and BellSouth is prohibited by said lease from offering such an option. The terms and conditions of the agreement between the Host and its Guests shall be written and AT&T shall provide written notice to BellSouth that it has entered into a shared arrangement prior to submitting an application for said Guest. Further, said agreement shall incorporate by reference the rates, terms, and conditions of this Attachment 4.
- 3.3.1 AT&T shall be the sole interface and responsible party to BellSouth for the purpose of submitting applications for initial and additional equipment placements of Guest; for assessment of rates and charges contained within this Attachment; and for the purposes of ensuring that the safety and security requirements of this Attachment are fully complied with by the Guest, its employees and agents. In the event the Host and Guest jointly submit an initial Application, only one Application Fee will be assessed. A separate initial Guest Application shall require the assessment of a Subsequent Application Fee, as set forth in Exhibit C, if this Application is not the initial Application made for the arrangement. Notwithstanding the foregoing, Guest may arrange directly with BellSouth for the provision of the interconnecting facilities between BellSouth and Guest and for the provisions of the services and access to Network Elements.
- 3.3.2 AT&T shall indemnify and hold harmless BellSouth from any and all claims, actions, causes of action, of whatever kind or nature arising out of the presence of AT&T's Guests in the Collocation Space.

- 3.4 Adjacent Collocation. BellSouth will make available, where space is legitimately exhausted in a particular BellSouth Premises, collocation in adjacent controlled environmental vaults or similar structures to the extent technically feasible. BellSouth will permit AT&T to construct or otherwise procure such an adjacent structure, subject only to reasonable safety and maintenance requirements. BellSouth will provide power and physical collocation services and facilities, subject to the same nondiscrimination requirements as applicable to any other physical collocation arrangement. BellSouth will permit AT&T to place its own equipment, including, but not limited to, copper cables, coaxial cables, fiber cables, and telecommunications equipment, in adjacent facilities constructed by either BellSouth or by AT&T itself. The Adjacent Arrangement shall be constructed or procured by AT&T and in conformance with BellSouth's reasonable safety and maintenance requirements. BellSouth will provide specifications upon request. Further, AT&T shall construct, procure, maintain and operate said Adjacent Arrangement(s) pursuant to all of the terms and conditions set forth in this Attachment. Rates shall be as set forth in Exhibit C.
- 3.4.1 Should AT&T elect such option, AT&T must arrange with a BellSouth Certified Vendor to construct an Adjacent Arrangement structure. Where local building codes require enclosure specifications more stringent than BellSouth's standard specification, AT&T and AT&T's contractor must comply with local building code requirements. AT&T's contractor shall be responsible for filing and receiving any and all necessary zoning, permits and/or licenses for such construction. BellSouth shall cooperate with AT&T and provide, at AT&T's expense, the documentation necessary for AT&T to obtain the zoning, permits and/or other licenses. BellSouth shall pass on to AT&T the costs of providing the documentation. AT&T's BellSouth Certified Vendor shall bill AT&T directly for all work performed for AT&T pursuant to this Attachment and BellSouth shall have no liability for nor responsibility to pay such charges invoiced by the Certified Vendor.
- 3.4.2 BellSouth may inspect the Adjacent Arrangement(s) following construction and prior to the Commencement Date, as defined in Section 4.1 of this Attachment 4, to ensure the design and construction comply with BellSouth's specifications. BellSouth may require AT&T, at AT&T's sole cost, to correct any deviations from BellSouth's specifications found during such inspection(s), up to and including removal of the Adjacent Arrangement, within five (5) business days of BellSouth's inspection, unless the Parties mutually agree to an alternative time frame.
- 3.4.3 AT&T shall provide a concrete pad, the structure housing the arrangement, HVAC, lighting, and all facilities that connect the

structure (i.e. racking and conduit) to the BellSouth point of interconnection. At AT&T's option, BellSouth shall provide an AC power source and access to physical collocation services and facilities subject to the same nondiscriminatory requirements as applicable to any other physical collocation arrangement.

- 3.4.4 Where AT&T has elected to construct the adjacent enclosure itself, BellSouth shall deliver to AT&T the requested ground space thirty (30) days after BellSouth receives AT&T's Bona Fide Firm Order.
- 3.4.5 BellSouth shall allow other telecommunications carriers to share AT&T's Adjacent Arrangements pursuant to the terms and conditions set forth in Section 3.3 and Section 3.3.1 above.
- 3.4.6 If physical collocation space becomes available in a previously exhausted BellSouth structure, BellSouth must not require AT&T to move or prohibit AT&T from moving, a collocation arrangement into that structure in accordance with the rates terms and conditions of this Attachment 4. Instead, BellSouth must continue to allow AT&T to collocate in any adjacent controlled environmental vault, controlled environmental vault or similar structure that AT&T has constructed or procured unless otherwise agreed to by the Parties or as ordered by the Kentucky Public Service Commission

4. OCCUPANCY

- 4.1 Commencement Date. The "Commencement Date" shall be the day AT&T's equipment becomes operational as described in Section 4.2 of this Attachment 4.
- 4.2 Occupancy. BellSouth will notify AT&T in writing that the Collocation Space is ready for occupancy. AT&T must place operational telecommunications equipment in the Collocation Space and begin either receiving access to Network Elements or interconnecting with BellSouth's network within one hundred eighty (180) days after receipt of such notice. AT&T must notify BellSouth in writing that collocation equipment installation is complete and is operational with BellSouth's network. If AT&T fails to place operational telecommunications equipment in the Collocation Space within 180 calendar days and such failure continues for a period of thirty (30) days after receipt of written notice from BellSouth, then BellSouth may, upon thirty (30) days written notice, request AT&T to return the space. AT&T is not required to return the space if, within that thirty (30) day period: (1) AT&T utilizes the space by placing equipment in the space; (2) AT&T provides BellSouth a legitimate business plan within fifteen (15)

calendar days showing its intent to utilize the space within forty-five (45) days of submitting the business plan; or (3) AT&T enters into a sharing relationship for its space pursuant to Section 3.4 of this Attachment 4. In the event that AT&T does not satisfy any of the foregoing conditions, its right to occupy the Collocation Space terminates and BellSouth shall have no further obligations to AT&T with respect to said Collocation Space. However, for good cause shown, AT&T may request and BellSouth will grant an extension of up to 30 days, unless otherwise mutually agreed to by the parties. [7/12/01 Closed]. Termination of AT&T's rights to the Collocation Space pursuant to this section shall not operate to release AT&T from its obligation to reimburse BellSouth for all unpaid costs reasonably incurred by BellSouth pursuant to Section 4.2.2 of this Attachment 4 in preparing the Collocation Space, but rather such obligation shall survive this Attachment. For purposes of this Section 4.2, AT&T's telecommunications equipment will be deemed operational when cross-connected to BellSouth's network for the purpose of service provision.

- 4.2.1 If, after the initial installation of AT&T's equipment, the initial connections provided by BellSouth on BellSouth's side of the demarcation point do not allow AT&T's equipment to function in a manner that allows AT&T to provide telecommunications services to its end users, BellSouth will credit AT&T the floor space charges for the period of time that the AT&T equipment is not operational due to the faulty connections. Such credit will also include a pro rata credit for cross-connections and any Network Elements ordered and installed and will not apply if the malfunction results from BellSouth provisioning such connections in accordance with AT&T specifications.
- 4.2.2 Termination. Except where otherwise agreed to by the Parties, AT&T may terminate occupancy in a particular Collocation Space upon thirty (30) calendar days prior written notice to BellSouth. Upon termination of such occupancy, AT&T at its expense shall remove its equipment and other property from the Collocation Space. AT&T shall have thirty (30) calendar days from the termination date to complete such removal, including the removal of all equipment and facilities of any other occupant of AT&T's Collocation Space; provided, however, that AT&T shall continue payment of monthly fees to BellSouth until such date as AT&T has fully vacated the Collocation Space. Upon expiration of this Attachment, AT&T shall surrender the Collocation Space to BellSouth in the same condition as when first occupied by the AT&T except for ordinary wear and tear. Unless otherwise agreed upon by the Parties, AT&T shall be responsible for the cost of removing any enclosure, together with all support structures (e.g., racking, conduits), of an Adjacent Collocation arrangement at the

termination of occupancy and restoring the grounds to their original condition.

5. USE OF COLLOCATION SPACE

- 5.1 Equipment Type. BellSouth shall permit the collocation of any type of equipment necessary for interconnection or for access to Network Elements in the provision of telecommunications services. Such equipment necessary for interconnection and access to Network Elements includes, but is not limited to transmission equipment including, but not limited to, optical terminating equipment and multiplexers, equipment being collocated to terminate basic transmission facilities pursuant to § 64.1401 and § 64.1402 of Title 47 of the Code of Federal Regulations as of August 1, 1996, and digital subscriber line access multiplexers, routers, asynchronous transfer mode multiplexers, remote switching modules, and digital/optical cross-connect panels, and digital loop carrier. Nothing in this section requires BellSouth to permit collocation of equipment used solely for switching or solely to provide enhanced services; provided, however, that BellSouth may not place any limitations on the ability of AT&T to use all the features, functions, and capabilities of equipment collocated including, but not limited to, switching and routing features and functions and enhanced services functionalities.
- 5.1.1 Such equipment must at a minimum meet the following BellCore (Telcordia) Network Equipment Building Specifications (NEBS) General Equipment Requirements: Criteria Level 1 requirements as outlined in the BellCore (Telcordia) Special Report SR-3580, Issue 1; equipment design spatial requirements per GR-63-CORE, Section 2; thermal heat dissipation per GR-063-CORE, Section 4, Criteria 77-79; acoustic noise per GR-063-CORE, Section 4, Criterion 128, and National Electric Code standards. BellSouth may not object to the Collocation of equipment on the ground that the equipment fails to comply with NEBS performance standards.
- 5.1.2 AT&T shall not use the Collocation Space for marketing purposes nor shall it place any advertising signs or markings in the area surrounding the Collocation Space or on the grounds of the Premises.
- 5.1.3 AT&T shall place a plaque or other identification affixed to AT&T's equipment, cage or adjacent structure necessary to identify AT&T's equipment, including a list of emergency contacts with telephone numbers.

- 5.1.4 BellSouth shall not impose any performance standards, except for safety, on AT&T equipment. These safety standards will not exceed the standards that BellSouth imposes on its own equipment, its subsidiaries' equipment, or to the equipment of any third person.
- 5.2 For both Physical Collocation and Virtual Collocation, AT&T may either purchase unbundled transmission facilities (and any necessary cross-connection) from BellSouth or provide its own or third-party leased transmission facilities and terminate those transmission facilities in its equipment located in its Collocation Space at BellSouth's Premises.
- 5.3 Entrance Facilities. AT&T may elect to place AT&T-owned or AT&T-leased entrance facilities into the Collocation Space. BellSouth will designate the point of interconnection as close as reasonably possible to the Premises housing the Collocation Space, such as an entrance manhole or a cable vault which are physically accessible by both Parties. AT&T will provide and place fiber cable at the point of interconnection of sufficient length to be pulled through conduit and into the splice location. If AT&T desires to place cable other than fiber, BellSouth shall permit interconnection using copper or coaxial cable if such interconnection is first approved by the Commission. AT&T will provide and install a sufficient length of fire retardant riser cable, to which the entrance cable will be spliced, which will extend from the splice location to the AT&T's equipment in the Collocation Space. AT&T must arrange for BellSouth to splice the entrance facility to AT&T-provided riser cable. In the event AT&T utilizes a non-metallic, riser-type entrance facility, a splice will not be required. Pursuant to the AT&T/BellSouth Right-of-Way Attachment 8, incorporated herein by this reference, AT&T must contact BellSouth for instructions prior to placing the entrance facility cable in the manhole. AT&T is responsible for maintenance of the entrance cable.
- 5.3.1 Dual Entrance. BellSouth will provide at least two (2) such Interconnection points at each BellSouth Premises at which there are at least two (2) entry points for BellSouth's cable facilities, and at which space is available for new facilities in at least two (2) of those entry points. In response to a request for physical collocation under this Attachment, BellSouth shall provide AT&T with information regarding BellSouth's capacity to accommodate dual entrance facilities. Consistent with Attachment 8, incorporated herein by this reference, if conduit in the serving manhole(s) is available and is not reserved for another purpose, BellSouth will make the requested conduit space available for installing a second entrance facility to AT&T's arrangement. The location of the serving manhole(s) will be determined at the sole discretion of BellSouth so long as the location selected is as close as reasonably possible. Where dual entrance is

not available due to lack of capacity, BellSouth will so state in the Application Response.

- 5.3.2 Shared Use. AT&T may utilize spare capacity on an existing telecommunications service providers entrance facility for the purpose of providing an entrance facility to another AT&T collocation arrangement within the same Premises. AT&T must arrange for BellSouth to splice the entrance facility to AT&T-provided riser cable.
- 5.4 Splicing in the Entrance Manhole. Although not generally permitted, should AT&T request a splice to occur in the entrance manhole(s), BellSouth, at its sole discretion, may grant such a request, provided that BellSouth will not unreasonably withhold approval of requests to make such a splice. When the request for a splice is granted to AT&T by BellSouth, AT&T shall ensure its employees or agents entering and/or performing work in the entrance manhole(s) are trained and comply with BellSouth procedures and OSHA requirements regarding access to manholes and that BellSouth personnel are notified and present for all entrances and work performed in the entrance manhole(s). Manhole covers shall be properly closed and secured at the conclusion of entry and/or work. Advance notification to BellSouth shall occur at a minimum of 48 hours prior to desired entry for normal work activities and at a minimum of 2 hours prior to desired entry in an out of service condition.
- 5.5 Demarcation Point. For the purposes of this Attachment, BellSouth will designate the point(s) of interconnection between AT&T's equipment and/or network and BellSouth's network located as close as reasonably possible to AT&T's Collocation Space. Each Party will be responsible for maintenance and operation of all equipment/facilities on its side of the demarcation point. BellSouth will not require AT&T to use an intermediate interconnection arrangement in lieu of direct connection to BellSouth's network, if technically feasible. For 2-wire and 4-wire connections to BellSouth's network, the demarcation point shall be a common block on the BellSouth designated conventional distributing frame. AT&T shall be responsible for providing, and AT&T's BellSouth Certified Vendor shall be responsible for installing and properly labeling/stenciling, the common block, and necessary cabling pursuant to Section 6.3 of this Attachment 4. For all other terminations BellSouth shall designate a demarcation point on a per arrangement basis. AT&T or its agent must perform all required maintenance to equipment/facilities on its side of the demarcation point, pursuant to Section 5.6 of this Attachment 4, and may self-provision cross-connects that may be required within the collocation space to activate service requests. At AT&T's option, expense, and if space permits, a Point of Termination ("POT") bay or frame may be

placed in the Collocation Space but shall not serve as the demarcation point, but may serve as a testing point.

- 5.6 AT&T's Equipment and Facilities. AT&T, or if required by this Attachment, AT&T's BellSouth certified vendor, is solely responsible for the design, engineering, installation, testing, provisioning, performance, monitoring, maintenance and repair of the equipment and facilities used by AT&T. Such equipment and facilities may include but are not limited to cable(s); equipment; and point of termination connections. Before beginning delivery, installation, replacement or removal work for equipment and/or facilities located within the Collocation Space, AT&T shall obtain BellSouth's approval of AT&T's proposed scheduling of the work in order to coordinate use of temporary staging areas and other building facilities. BellSouth may request additional information before granting approval.
- 5.7 Easement Space. From time to time BellSouth may require access to the Collocation Space. BellSouth retains the right to access such space for the purpose of making BellSouth equipment and building modifications (e.g., running, altering or removing racking, ducts, electrical wiring, HVAC, and cables). BellSouth will give reasonable notice to AT&T when access to the Collocation Space is required and provide a list of names of individuals authorized to enter said space. AT&T may elect to be present whenever BellSouth performs work in the Collocation Space. The Parties agree that AT&T will not bear any of the expense associated with this work.
- 5.8 Access. Pursuant to Section 11 of this Attachment 4, AT&T shall have access to the Collocation Space twenty-four (24) hours a day, seven (7) days a week. AT&T agrees to provide the name and either Driver's License, social security number, or date of birth of each employee, contractor, or agents provided with Access Keys or cards ("Access Keys") prior to the issuance of said Access Keys. Access Keys shall not be duplicated under any circumstances. AT&T agrees to be responsible for all Access Keys and for the return of all said Access Keys in the possession of AT&T employees, contractors, other occupants of AT&T's Collocation Space, or agents after termination of the employment relationship, contractual obligation with AT&T or upon the termination of this Attachment or the termination of occupancy of an individual collocation arrangement. Within sixty (60) days of the Effective Date of this Agreement, BellSouth and AT&T shall establish an agreed upon procedure for the return and confirmation of the return of Access Keys. Within ten (10) business days after receipt of AT&T's Bona Fide Order, BellSouth and AT&T will visit, without charge, AT&T's designated collocation arrangement location. BellSouth must

allow AT&T reasonable access to its selected collocation space during construction after receipt of a Bona Fide Firm Order.

- 5.8.1 Security Escort. A security escort will be required whenever AT&T or its agent desires access to the entrance manhole or must have access to the Premises after the one accompanied site visit allowed after Bona Fide Firm Order without charge to AT&T prior to completing BellSouth's Security Training requirements and/or prior to Space Acceptance. Rates for a security escort are assessed in one-half (1/2) hour increments according to the schedule appended hereto as Exhibit C.
- 5.8.2 Lost or Stolen Access Keys. AT&T shall notify BellSouth in writing immediately in the case of lost or stolen Access Keys. AT&T will reimburse BellSouth the reasonable costs to replace each Access Key lost or stolen. Should it become necessary for BellSouth to re-key buildings as a result of a lost Access Key(s) or for failure to return an Access Key(s), AT&T shall pay for all reasonable costs associated with the re-keying. AT&T must submit to BellSouth the completed Access Control Request Form (RF-2906-C) for all employees or agents requiring access to the BellSouth Premises a minimum of thirty (30) calendar days prior to the date AT&T desires access to the Collocation Space.
- 5.8.3 AT&T authorized personnel will have immediate access to health related facilities (e.g., bathrooms, eyewash stations, shower stations, drinking water, etc., within the collocated facility), as well as access to parking.
- 5.9 Interference or Impairment. Notwithstanding any other provisions of this Attachment, equipment and facilities placed in the Collocation Space by AT&T shall not interfere with or impair service provided by BellSouth or by any other telecommunications carriers located in the Premises; shall not endanger or damage the facilities of BellSouth or of any other telecommunications carrier located in the Premises, the Collocation Space, or the Premises; shall not compromise the privacy of any communications carried in, from, or through the Premises; and shall not create an unreasonable risk of injury or death to any individual or to the public. If BellSouth reasonably determines that any equipment or facilities of AT&T violates the provisions of this paragraph, BellSouth shall give written notice to AT&T, which notice shall direct AT&T to cure the violation within forty-eight (48) hours of AT&T's actual receipt of written notice or, at a minimum, to commence curative measures within 24 hours and to exercise reasonable diligence to complete such measures as soon as possible thereafter. After receipt of the notice, the Parties agree to consult immediately

and, if necessary, to inspect the arrangement. If AT&T fails to take any action within 48 hours of receipt of the written notice or if the violation is of a character which poses an immediate and substantial threat of damage to property, injury or death to any person, or interference/impairment of the services provided by BellSouth or any other telecommunications carrier located in the Premises, then and only in that event BellSouth may take such action as it deems appropriate to correct the violation, including without limitation the interruption of electrical power to AT&T's equipment. BellSouth will endeavor, but is not required, to provide notice to AT&T prior to taking such action and shall have no liability to AT&T for any damages arising from such action, except to the extent that such action by BellSouth constitutes willful misconduct.

- 5.9.1 AT&T will be responsible for notifying BellSouth of any significant outages of AT&T's equipment which could impact any of the services offered by BellSouth, and provide estimated clearing time for restoration.
- 5.10 Personalty and its Removal. Subject to requirements of this Attachment, AT&T may place or install in or on the Collocation Space such facilities and equipment, including storage for and spare equipment, as it deems desirable for the conduct of business, provided that such equipment is telecommunications equipment, does not violate floor loading requirements, imposes or could impose or contains or could contain environmental conditions or hazards. Personal property, facilities and equipment placed by AT&T in the Collocation Space shall not become a part of the Collocation Space, even if nailed, screwed or otherwise fastened to the Collocation Space, but shall retain their status as personalty and may be removed by AT&T at any time. Any damage caused to the Collocation Space by AT&T's employees, agents or representatives during the removal of such property shall be promptly repaired by AT&T at its expense.
- 5.11 Alterations. In no case shall AT&T or any person acting on behalf of AT&T make any rearrangement, modification, improvement, addition, repair, or other alteration to the Collocation Space or the BellSouth Premises without the written consent of BellSouth, which consent shall not be unreasonably withheld. The cost of any such specialized alterations shall be paid by AT&T.
- 5.12 Janitorial Service. AT&T will not be responsible for costs associated with maintenance and upkeep of the building. AT&T shall be responsible for the general upkeep and cleaning of the Caged Collocation Space and shall arrange directly with a BellSouth Certified

Vendor for janitorial services. BellSouth shall provide a list of such contractors on a site-specific basis upon request.

6. ORDERING AND PREPARATION OF COLLOCATION SPACE

6.1 Application for Space. AT&T shall submit an application document when AT&T or AT&T's Guest(s), as defined in Section 3.3 and Section 3.3.1 of this Attachment 4, desires to request or modify the use of the Collocation Space. BellSouth shall provide AT&T with a single point of contact for all inquiries regarding collocation.

6.1.1 Initial Application. For AT&T or AT&T's Guest(s) initial equipment placement, AT&T shall submit to BellSouth a complete and accurate (complete and accurate means all required fields are filled in with the appropriate type of information) Application and Inquiry document ("Bona Fide Application"). The Bona Fide Application shall contain a detailed description and schematic drawing of the equipment to be placed in AT&T's Collocation Space(s) and an estimate of the amount of square footage required.

6.1.2 Subsequent Application Fee. In the event AT&T or AT&T's Guest(s) desire to modify the use of the Collocation Space, AT&T shall complete a Bona Fide Application detailing all information regarding the modification to the Collocation Space. BellSouth shall determine what modifications, if any, to the Premises are required to accommodate the change requested by AT&T in the Bona Fide Application. Such necessary modifications to the Premises may include but are not limited to, floor loading changes, changes necessary to meet HVAC requirements, changes to power plant requirements, and equipment additions. The fee paid by AT&T for its request to modify the use of the Collocation Space shall be dependent upon the modification requested. Where the subsequent application does not require provisioning or construction work by BellSouth, no Subsequent Application Fee will be required. The fee for an application where the modification requested has limited effect (e.g., does not require capital expenditure by BellSouth) shall be the Subsequent Application Fee as set forth in Exhibit C to Attachment 4. In the event that the modification requires a capital expenditure by BellSouth, the Application Fee set forth in Exhibit C to Attachment 4 shall be assessed. In such event, the Subsequent Application Fee shall be considered a partial payment of the Application Fee, and the outstanding balance (Application Fee minus Subsequent Application Fee) shall be due from AT&T within thirty (30) calendar days following AT&T's receipt of a bill or invoice from BellSouth.

- 6.2 Application Response. In addition to the notice of space availability pursuant to Section 2.1 of this Attachment 4, BellSouth will include in its response whether the application is Bona Fide, and if it is not Bona Fide, the items necessary to cause the application to become Bona Fide. When space has been determined to be available, BellSouth will provide a written response (“Application Response”) within twenty-three (23) business days of receipt of a Bona Fide Application. The Application Response will include, at a minimum, the configuration of the space, the Cable Installation Fee, Cable Records Fee, and the space preparation fees, as described in Section 7. When BellSouth's response includes an amount of space less than that requested by AT&T or differently configured, AT&T must amend its application to reflect the actual space available prior to submitting a Bona Fide Firm Order.
- 6.3 Bona Fide Firm Order. AT&T shall indicate its intent to proceed with equipment installation in a BellSouth Premises by submitting a Bona Fide Firm Order to BellSouth. A Bona Fide Firm Order requires AT&T to complete the Bona Fide Application process described in Section 6.1 of this Attachment 4, and submit the Expanded Interconnection Bona Fide Firm Order document (BSTEI-1P-F) indicating acceptance of the written application response provided by BellSouth (“Bona Fide Firm Order”). The Bona Fide Firm Order must be received by BellSouth no later than five (5) business days after BellSouth's response to AT&T's Bona Fide Application.
- 6.3.1 The firm order date will be the date BellSouth receives a Bona Fide Firm Order. BellSouth will acknowledge the receipt of AT&T's Bona Fide Firm Order within seven (7) calendar days of receipt indicating that the Bona Fide Firm Order has been received. A BellSouth response to a Bona Fide Firm Order will include a Firm Order Confirmation containing the firm order date.
- 6.3.2 Within ten (10) business days after receipt of AT&T's Bona Fide Order, BellSouth and AT&T will visit, without charge, AT&T's designated collocation arrangement location.
- 6.3.3 Space preparation for the Collocation Space will not begin until BellSouth receives the Bona Fide Firm Order.
- 6.4 Construction and Provisioning Interval BellSouth will complete construction for collocation arrangements within seventy-six (76) business days from receipt of an Application or as agreed to by the Parties. Under extraordinary conditions, BellSouth will complete construction for collocation arrangements within ninety-one (91) business days. Examples of extraordinary conditions include, but are

not limited to, extended license or permitting intervals; major BellSouth equipment rearrangement or addition; power plant addition or upgrade; major mechanical addition or upgrade; major upgrade for ADA compliance; environmental hazard or hazardous materials abatement; and arrangements for which equipment shipping intervals are extraordinary in length. In the event AT&T submits a forecast as described in the following section three (3) months or more prior to the application date, the above intervals shall apply. In the event AT&T submits such a forecast between two (2) months and three (3) months prior to the application date, the above intervals may be extended by one (1) additional month. In the event AT&T submits such a forecast less than two (2) months prior to the application date, the above intervals may be extended by sixty (60) calendar days. BellSouth will attempt to meet standard intervals for unforecasted requests and any interval adjustments will be discussed with AT&T at the time the application is received. Raw space, which is space lacking the necessary infrastructure to provide collocation space including but not limited to HVAC, Power, etc.), conversion time frames fall outside the normal intervals and are negotiated on an individual case basis. Additionally, augments and installations to existing collocation arrangements for line sharing or line splitting, which include adding cable, adding cable and splitter, and adding a splitter, will be forty five (45) business days from receipt of an Application.

- 6.4.1 To be considered a timely and accurate forecast, AT&T must submit to BellSouth the CLEC Forecast Form contained in Exhibit B of this Attachment, containing the following information: Central Office/Serving Wire Center CLLI, number of Caged square feet and/or Cageless bays, number of DS0, DS1, DS3 frame terminations, number of fused amps and planned application date.
- 6.4.2 Joint Planning Meeting. Unless otherwise agreed to by the Parties, a joint planning meeting or other method of joint planning between BellSouth and AT&T will commence within a maximum of 15 business days from BellSouth's receipt of a Bona Fide Firm Order. At such meeting, the Parties will agree to the preliminary design of the Collocation Space and the equipment configuration requirements as reflected in the Application and affirmed in the Bona Fide Firm Order. The Collocation Space Completion time period will be provided to AT&T during the joint planning meeting or as soon as possible thereafter. BellSouth will complete all design work following the joint planning meeting.
- 6.4.3 Permits. Each Party or its agents will diligently pursue filing for the permits required for the scope of work to be performed by that Party or its agents within 7 business days of the completion of finalized construction designs and specifications.

- 6.4.4 Acceptance Walk Through. AT&T and BellSouth will complete an acceptance walk through of each Collocation Space requested from BellSouth by AT&T. The acceptance walk through shall occur within 15 calendar days of BellSouth's notification to AT&T that the collocation space is ready for occupancy. BellSouth will correct any deviations to AT&T's original or jointly amended requirements within five (5) business days after the walk through, unless the Parties jointly agree upon a different time frame. The correction of these deviations from AT&T's original request for collocation shall be at BellSouth's expense. At the end of the acceptance walk through or after any deviations are corrected, AT&T will execute a written document accepting the Collocation Space.
- 6.5 Use of Certified Vendor. A "BellSouth Certified Vendor" is a vendor that has been certified by BellSouth to perform certain activities pursuant to BellSouth's certified vendor program. AT&T shall select a vendor which has been approved as a BellSouth Certified Vendor to perform all engineering and installation work required in the Collocation Space. In some cases, AT&T must select separate BellSouth Certified Vendors for transmission equipment, switching equipment and power equipment. BellSouth shall provide AT&T with a list of Certified Vendors upon request. The Certified Vendor(s) shall be responsible for installing AT&T's equipment and components, extending power cabling to the BellSouth power distribution frame, performing operational tests after installation is complete, and notifying BellSouth's equipment engineers and AT&T upon successful completion of installation. The Certified Vendor shall bill AT&T directly for all work performed for AT&T pursuant to this Attachment and BellSouth shall have no liability for nor responsibility to pay such charges imposed by the Certified Vendor. BellSouth shall certify AT&T or any vendor proposed by AT&T when either satisfactorily completes BellSouth's certified vendor program.
- 6.6 Alarm and Monitoring. BellSouth shall place environmental alarms in the Premises for the protection of BellSouth's and AT&T's equipment and facilities. Should AT&T elect to place alarms within its Collocation Space, AT&T shall be responsible for placement, monitoring and removal of environmental and equipment alarms used to service AT&T's Collocation Space. Upon request, BellSouth will provide AT&T with applicable tariffed service(s) to facilitate remote monitoring of collocated equipment by AT&T. Both Parties shall use best efforts to notify the other of any verified environmental hazard known to that Party. The Parties agree to utilize and adhere to the Environmental and Safety Principles identified as Exhibit A attached hereto.

- 6.7 Power. BellSouth shall supply -48 Volt (-48V) DC power, including back-up power, for AT&T's Collocation Space within the Premises and shall make available AC power at AT&T's option for Adjacent Arrangement collocation. The power provided to AT&T by BellSouth shall be at least equal in quality and service level as that which is provided by BellSouth to itself or to any third party. When obtaining AC power from a BellSouth Service Panel, fuses and power cables must be engineered (sized) and installed by AT&T's BellSouth Certified Vendor. AT&T's BellSouth Certified Vendor must also provide a copy of the engineering power specification prior to the Commencement Date. When obtaining power from a BellSouth Battery Distribution Fuse Bay, fuses and power cables (A&B) must be engineered (sized) and installed by AT&T's BellSouth Certified Vendor. Electrical engineering standards require that the fuse positions for power feeders must exceed the actual drain (or expected consumption) by 50%. When obtaining power from a BellSouth Power Board, power cables (A&B) must be engineered (sized) and installed by AT&T's BellSouth Certified Vendor. AT&T's BellSouth Certified Vendor must also provide a copy of the engineering power specification prior to the Commencement Date. BellSouth may be required to construct additional DC power plant or upgrade the existing DC power plant in a Premises as a result of AT&T's request to collocate in that Premises ("Power Plant Construction"). The determination of whether Power Plant Construction is necessary shall be within BellSouth's sole, but reasonable, discretion. BellSouth shall comply with all Telcordia and ANSI Standards regarding power cabling, including Telcordia Network Equipment Building System (NEBS) Standard GR-63-CORE. If BellSouth has not previously provided for power plant capacity for collocation at a specific site, then AT&T has the option to add its own dedicated power plant; provided, however, that such work shall be performed by a BellSouth Certified Vendor and such contractor shall comply with BellSouth's guidelines and specifications. Where AT&T performs its own dedicated Power Plant Construction, upon termination of this Attachment AT&T shall have the right to remove its equipment from the power plant room, but shall otherwise leave the room intact. The termination and grounding locations shall be as mutually agreed upon by the Parties.
- 6.8 Basic Telephone Service. Upon request of AT&T, BellSouth will provide basic telephone service to the Collocation Space under the rates, terms and conditions of the current tariff offering for the service requested.
- 6.9 Space Preparation. Space preparation fees consist of a nonrecurring charge for Firm Order Processing and monthly recurring charges for Central Office Modifications, assessed per arrangement, per square

foot, and Common Systems Modifications, assessed per arrangement, per square foot for cageless and per cage for caged collocation. AT&T shall remit payment of the nonrecurring Firm Order Processing Fee coincident with submission of a Bona Fide Firm Order. The recurring charges for space preparation apply beginning on the date on which BellSouth releases the Collocation Space for occupancy or on the date AT&T first occupies the Collocation Space, whichever is sooner. The charges recover the costs associated with preparing the Collocation Space, which includes survey, engineering of the Collocation Space, design and modification costs for network, building and support systems. In the event AT&T opts for cageless space, the space preparation fees will be assessed based on the total floor space dedicated to AT&T as prescribed in Section 7.4. BellSouth will reimburse AT&T in an amount equal to AT&T's reasonable, demonstrative and mitigated expenditures incurred as a direct result of delays to the completion and turnover dates caused by BellSouth, but only to the extent such expenditures are not recovered through Attachment 9 of this Agreement

- 6.10 Virtual Collocation Transition. BellSouth offers Virtual Collocation pursuant to the rates, terms and conditions set forth in its F.C.C. Tariff No. 1. For the interconnection to BellSouth's network and access to BellSouth Network Elements, AT&T may purchase Cross-Connects as set forth in Exhibit C, and AT&T may designate within its Virtual Collocation arrangements the placement of telecommunications equipment set forth in Section 5.1 of this Attachment 4. In the event physical collocation space was previously denied at a location due to technical reasons or space limitations, and that physical collocation space has subsequently become available, AT&T may transition its virtual collocation arrangements to physical collocation arrangements and pay the appropriate non-recurring fees for physical collocation and for the rearrangement or reconfiguration of services terminated in the virtual collocation arrangement. In the event that BellSouth knows when additional space for physical collocation may become available at the location requested by AT&T, such information will be provided to AT&T in BellSouth's written denial of physical collocation. To the extent that (i) physical collocation space becomes available to AT&T within 180 days of BellSouth's written denial of AT&T's request for physical collocation, and (ii) AT&T was not informed in the written denial that physical collocation space would become available within such 180 days, then AT&T may transition its virtual collocation arrangement to a physical collocation arrangement and will receive a credit for any nonrecurring charges previously paid for such virtual collocation. AT&T must arrange with a BellSouth certified vendor for the relocation of equipment from its virtual collocation space to its physical collocation space and will bear the cost of such relocation.

- 6.10.1 BellSouth will authorize the conversion of virtual collocation arrangements to physical collocation arrangements without requiring the relocation of the virtual arrangement where there are no extenuating circumstances or technical reasons that would cause the arrangement to become a safety hazard within the Premises or otherwise being in conformance with the terms and conditions of this Attachment and where (1) there is no change to the arrangement; (2) the conversion of the virtual arrangement would not cause the arrangement to be located in the area of the Premises reserved for BellSouth's forecast of future growth; and (3) due to the location of the virtual collocation arrangement, the conversion of said arrangement to a physical arrangement would not impact BellSouth's ability to secure its own facilities. Notwithstanding the foregoing, if the BellSouth Premises is at or nearing space exhaust, BellSouth may authorize the conversion of the virtual arrangement to a physical arrangement even though BellSouth could no longer secure its own facilities.
- 6.11 Cancellation. If, at anytime, AT&T cancels its order for the Collocation Space(s), BellSouth shall return that portion of the charges paid by AT&T which exceed any expenses incurred up to the date that written notice of the cancellation is received. If BellSouth can demonstrate that BellSouth's expenses exceeded the estimated charges paid by AT&T, AT&T will pay BellSouth the additional charges. In no event will the level of reimbursement under this paragraph exceed the maximum amount AT&T would have otherwise paid for work undertaken by BellSouth if no cancellation of the order had occurred.
- 6.12 Licenses. AT&T, at its own expense, will be solely responsible for obtaining from governmental authorities, and any other appropriate agency, entity, or person, all rights, privileges, and licenses necessary or required to operate as a provider of telecommunications services to the public or to occupy the Collocation Space.

7 RATES AND CHARGES

- 7.1 BellSouth may begin billing AT&T for recurring charges for the Collocation Space on the date that AT&T executes the written document accepting the Collocation Space pursuant to Section 6.4.4 of this Attachment, or on the date AT&T first occupies the Collocation Space whichever is sooner. If AT&T fails to schedule and complete a walkthrough pursuant to Section 6.4.4, then BellSouth shall begin billing AT&T for recurring charges as of the day after expiration of the timeframe in which AT&T is required to schedule and complete the acceptance walkthrough.

- 7.2 Documentation. BellSouth shall provide documentation to establish the actual Space Preparation Fee.
- 7.3 Cable Installation. Cable Installation Fee(s) are assessed per entrance cable placed.
- 7.4 Floor Space. The floor space charge includes reasonable charges for lighting, heat, air conditioning, ventilation and other allocated expenses associated with maintenance of the Premises but does not include amperage necessary to power AT&T's equipment. When the Collocation Space is enclosed, AT&T shall pay floor space charges based upon the number of square feet so enclosed. When the Collocation Space is not enclosed, AT&T shall pay floor space charges based upon the following floor space calculation: [(depth of the equipment lineup in which the rack is placed) + (0.5 x maintenance aisle depth) + (0.5 x wiring aisle depth)] X (width of rack and spacers). For purposes of this calculation, the depth of the equipment lineup shall consider the footprint of equipment racks plus any equipment overhang. BellSouth will assign unenclosed Collocation Space in conventional equipment rack lineups where feasible. In the event AT&T's collocated equipment requires special cable racking, isolated grounding or other treatment which prevents placement within conventional equipment rack lineups, AT&T shall be required to request an amount of floor space sufficient to accommodate the total equipment arrangement. Floor space charges are due beginning with the date on which BellSouth releases the Collocation Space for occupancy or on the date AT&T first occupies the Collocation Space, whichever is sooner.
- 7.5 Charges for -48V DC power will be assessed per ampere per month based upon the BellSouth Certified Vendor engineered and installed power feed fused ampere capacity. Rates include redundant feeder fuse positions (A&B) and cable rack to AT&T's equipment or space enclosure. In the event BellSouth shall be required to construct additional DC power plant or upgrade the existing DC power plant in a central office as a result of AT&T's request to collocate in that central office ("Power Plant Construction"), AT&T shall pay its pro-rata share of costs associated with the Power Plant Construction. BellSouth will notify AT&T of the need for the Power Plant Construction and will estimate the costs associated with the Power Plant Construction if BellSouth were to perform the Power Plant Construction. The costs of power plant construction shall be prorated and shared among all telecommunications carriers that benefit from that construction. The proration shall be based on the cost of providing one (1) ampere of DC power multiplied by the nominal drain requirements indicated by AT&T

in its physical collocation application. AT&T shall pay BellSouth one-half of its prorata share of the estimated Power Plant Construction costs prior to commencement of the work. AT&T shall pay BellSouth the balance due (actual cost less one-half of the estimated cost) within thirty (30) days of completion of the Power Plant Construction.

7.5.1 Charges for AC power will be assessed per breaker ampere per month based upon the BellSouth Certified Vendor engineered and installed power feed fused ampere capacity. Rates include the provision of commercial and standby AC power. Charges for AC power shall be assessed pursuant to the rates specified in Exhibit C of this Attachment 4, incorporated herein by this reference. AC power voltage and phase ratings shall be determined on a per location basis.

7.6 Other. If no rate is identified in the contract, the rate for the specific service or function will be negotiated by the Parties upon request by either Party. Payment of all other charges under this Attachment shall be due thirty (30) days after receipt of the bill (payment due date). AT&T will pay a late payment charge of one and one-half percent (1-1/2%) assessed monthly on any balance which remains unpaid after the payment due date.

8 INSURANCE

8.1 Insurance coverage shall be maintained pursuant to Section 21 of the General Terms and Conditions of this Agreement, incorporated herein by this reference.

9 MECHANICS LIENS

9.1 If any mechanics lien or other liens shall be filed against property owned by either Party (BellSouth or AT&T), or any improvement thereon by reason of or arising out of any labor or materials furnished or alleged to have been furnished or to be furnished to or for the other Party or by reason of any changes, or additions to said property made at the request or under the direction of the other Party, the other Party directing or requesting those changes shall, within thirty (30) days after receipt of written notice from the Party against whose property said lien has been filed, either pay such lien or cause the same to be bonded off the affected property in the manner provided by law. The Party causing said lien to be placed against the property of the other shall also defend, at its sole cost and expense, on behalf of the other, any action, suit or proceeding which may be brought for the enforcement of such liens and shall pay any damage and discharge any judgment entered thereon.

10. INSPECTIONS

- 10.1 BellSouth shall conduct an inspection of AT&T's equipment and facilities in the Collocation Space(s) prior to the activation of facilities between AT&T's equipment and equipment of BellSouth. BellSouth may conduct an inspection if AT&T adds equipment and may otherwise conduct routine inspections at reasonable intervals mutually agreed upon by the Parties. BellSouth shall provide AT&T with a minimum of forty-eight (48) hours or two (2) business days, whichever is greater, advance notice of all such inspections. All costs of such inspection shall be borne by BellSouth. If, as a result of the inspection by BellSouth, AT&T is found to be in non-compliance with the terms and conditions of this section, AT&T must modify its installation to achieve compliance.

11. SECURITY AND SAFETY REQUIREMENTS

- 11.1 The security and safety requirements set forth in this section are as stringent as the security requirements that BellSouth will maintain at its own premises either for its own employees or for authorized contractors. Only BellSouth employees, BellSouth Certified Vendors and authorized employees, authorized Guests, pursuant to Section 3.3 of this Attachment 4, or authorized agents of AT&T will be permitted in the BellSouth Premises. AT&T shall provide its employees and agents with picture identification which must be worn and visible at all times while in the Collocation Space or other areas in or around the Premises. The photo identification card shall bear, at a minimum, the employee's or agent's name and photo, and AT&T's name. BellSouth reserves the right to remove from its Premises any employee or agent of AT&T not possessing identification issued by AT&T. AT&T shall hold BellSouth harmless for any damages resulting from such removal of its personnel from BellSouth Premises in accordance with Section 10 of the General Terms and Conditions of this Agreement, incorporated herein by this reference. AT&T shall be solely responsible for ensuring that any Guest of AT&T is in compliance with all subsections of this Section 11.
- 11.2 AT&T will be required, at its own expense, to conduct a statewide investigation of criminal history records for each AT&T employee or agent hired from the hiring date of January 1, 1995 being considered for work on the BellSouth Premises, for the states/counties where the AT&T employee or agent has worked and lived for the past five years. AT&T shall conduct a criminal background investigation at parity with

the check BellSouth does for its employees from the hiring date of January 1, 1995. The scope, nature, and applicability of such criminal background check will be the same between the companies. Where state law does not permit statewide collection or reporting, an investigation of the applicable counties is acceptable.

- 11.3 AT&T will administer to their personnel assigned to the BellSouth Premises security training either provided by BellSouth or meeting criteria defined by BellSouth.

- 11.4 AT&T shall not assign to the BellSouth Premises any personnel with records of felony criminal convictions. AT&T shall not assign to the BellSouth Premises any personnel with records of misdemeanor convictions, except for misdemeanor traffic violations, without advising BellSouth of the nature and gravity of the offense(s). BellSouth reserves the right to refuse building access to any AT&T personnel who have been identified to have misdemeanor convictions. Notwithstanding the foregoing, in the event that AT&T chooses not to advise BellSouth of the nature and gravity of any misdemeanor conviction, AT&T may, in the alternative, certify to BellSouth that it shall not assign to the BellSouth Premises any personnel with records of misdemeanor convictions (other than misdemeanor traffic violations).

- 11.5 For each AT&T employee or agent hired from the hiring date of January 1, 1995 by AT&T, and being considered for work on the BellSouth Premises, who requires access to a BellSouth Premises pursuant to this Attachment, AT&T shall furnish BellSouth, prior to an employee or agent gaining such access, a certification that the aforementioned background check and security training were completed. The certification will contain a statement that no felony convictions were found and certifying that the security training was completed by the employee or agent. If the employee's or agent's criminal history includes misdemeanor convictions, AT&T will disclose the nature of the convictions to BellSouth at that time. In the alternative, AT&T may certify to BellSouth that it shall not assign to the BellSouth Premises any personnel with records of misdemeanor convictions other than misdemeanor traffic violations.

- 11.5.1 For all other AT&T employees requiring access to a BellSouth Premises pursuant to this Attachment, AT&T shall furnish BellSouth, prior to an employee gaining such access, a certification that the employee is not subject to the requirements of Section 11.5 above and that security training was completed by the employee.

- 11.6 At BellSouth's request, AT&T shall promptly remove from the BellSouth Premises any employee or agent of AT&T's BellSouth does not wish to grant access to its Premises pursuant to any investigation conducted by BellSouth.
- 11.7 Notification to BellSouth. BST reserves the right to interview AT&T's employees, agents, or contractors in the event of wrongdoing in or around BellSouth's property or involving BellSouth's or another CLEC's property or personnel, provided that BellSouth shall provide reasonable notice to AT&T's Security contact of such interview and arranges for AT&T's Security personnel to participate. AT&T and its contractors shall reasonably cooperate with BellSouth's investigation into allegations of wrongdoing or criminal conduct committed by, witnessed by, or involving AT&T's employees, agents, or contractors. Additionally, BellSouth reserves the right to bill AT&T for all reasonable costs associated with investigations involving its employees, agents or contractors if it is established and mutually agreed in good faith that AT&T's employees, agents or contractors are responsible for the alleged act. BellSouth shall bill AT&T for BellSouth property which is stolen or damaged where an investigation determines the culpability of AT&T's employees, agents or contractors and where AT&T agrees, in good faith, with the results of such investigation. AT&T shall notify BellSouth in writing immediately in the event that AT&T discovers one of its employees or agents already working on the BellSouth Premises is a possible security risk. Upon request of the other Party, the Party who is the employer shall discipline consistent with its employment practices, up to and including removal from the BellSouth Premises, any employee or agent found to have violated the security and safety requirements of this section. AT&T shall hold BellSouth harmless for any damages resulting from such removal of its personnel from BellSouth premises in accordance with Section 10 of the General Terms and Conditions of this Agreement, incorporated herein by this reference.
- 11.8 Use of Supplies. Unauthorized use of telecommunications equipment or supplies by either Party, whether or not used routinely to provide telephone service (e.g. plug-in cards), will be strictly prohibited and handled appropriately. Costs associated with such unauthorized use may be charged to the offending Party, as may be all associated investigative costs.
- 11.9 Use of Official Lines. Except for non-toll calls necessary in the performance of their work, neither party shall use the telephones of the other Party on the BellSouth Premises. Charges for unauthorized

telephone calls may be charged to the offending Party, as may be all associated investigative costs.

- 11.10 Accountability. Full compliance with the Security requirements of this section shall in no way limit the accountability of either Party to the other for the improper actions of its employees or agents.
- 11.11 BellSouth shall not use any information it collects in the course of implementing or operating security arrangements or other activities for marketing or any other purpose.
- 11.12 BellSouth shall exercise the same level of care it provides to itself to prevent harm or damage to AT&T, its employees, agents or end users, or their property. BellSouth agrees to take reasonable and prudent steps to ensure the adequate protection of AT&T property located within BellSouth Premises including, but not limited to:
 - 11.12.1 Agreeing not to use card access readers and devices that use cards that are encoded identically or mechanized coded locks on external doors or on internal doors to spaces that house AT&T equipment.
 - 11.12.2 Insure that the area that houses AT&T's equipment is adequately secured and monitored to prevent unauthorized entry.
 - 11.12.3 Assuring that the physical security and the means of ingress and admission to spaces that house AT&T equipment or equipment enclosures are equal to or exceed those provided for BellSouth pursuant to BellSouth admissions practices.
 - 11.12.4 Installing security studs in the hinge plates of doors having exposed hinges with removable pins if such leads to spaces that contain or house AT&T equipment or equipment enclosures.
 - 11.12.5 Controlling access from passenger and freight elevators by continuous surveillance or by installing security partitions, security grills, locked gates or doors between elevator lobbies and spaces that contain or house AT&T equipment or equipment enclosures.
 - 11.12.6 BellSouth will provide notification to designated personnel of an actual or attempted security breach of AT&T's Collocation Space, upon BellSouth discovery of such breach.

12 NOTIFICATION OF SERVICE AFFECTING ACTIVITY WITHIN THE BELL SOUTH PREMISES

12.1 BellSouth shall provide AT&T with written notice five (5) business days prior to those instances where BellSouth or its subcontractors may be performing non-emergency work that may directly affect the Collocation Space occupied by AT&T or that is directly related to AT&T circuits that support AT&T equipment. BellSouth will inform AT&T by telephone of any emergency-related activity that BellSouth or its subcontractors may be performing that may directly affect the Collocation Space occupied by AT&T or that is directly related to AT&T circuits that support AT&T equipment. Notification of any emergency-related activity shall be made as soon as practicable after BellSouth learns that such emergency activity is necessary but in no event longer than thirty (30) minutes after such time. To the extent that the Emergency Notification Process requires BellSouth to incur additional costs, AT&T shall reimburse BellSouth for such costs. The ACAC (Access Carrier Advocacy Center) shall be the single point of contact on all matters pertaining to the following areas:

- Equipment or Central Office Engineering
- Outside Plant Engineering
- Physical & Logical Security
- Provisioning
- Maintenance
- Billing
- Operations
- Site and Building Managers
- Environmental and Safety

13 DESTRUCTION OF COLLOCATION SPACE

13.1 In the event a Collocation Space is wholly or partially damaged by fire, windstorm, tornado, flood or by similar causes to such an extent as to be rendered wholly unsuitable for AT&T's permitted use hereunder, then either Party may elect within ten (10) days after such damage, to terminate this Attachment, only with respect to the damaged Collocation Space, and if either Party shall so elect, by giving the other written notice of termination, both Parties shall stand released of and from further liability under the terms hereof. If a Collocation Space shall suffer only minor damage and shall not be rendered wholly unsuitable for AT&T's permitted use, or is damaged and the option to terminate is not exercised by either Party, BellSouth covenants and agrees to proceed promptly without expense to AT&T, except for improvements not the property of BellSouth, to repair the damage. BellSouth shall have a reasonable time within which to rebuild or make

any repairs, and such rebuilding and repairing shall be subject to delays caused by storms, shortages of labor and materials, government regulations, strikes, walkouts, and causes beyond the control of BellSouth, which causes shall not be construed as limiting factors, but as exemplary only. AT&T may, at its own expense, accelerate the rebuild of its Collocation Space and equipment, provided however, that a BellSouth Certified Vendor is used and the necessary space preparation has been completed. Rebuild of equipment must be performed by a BellSouth Certified Vendor. If AT&T's acceleration of the project increases the cost of the project, then those additional charges will be incurred by AT&T. Where allowed and where practical, AT&T may erect a temporary facility while BellSouth rebuilds or makes repairs. In all cases where a damaged Collocation Space shall be rebuilt or repaired, AT&T shall be entitled to an equitable abatement of rent and other charges, depending upon the unsuitability of such damaged Collocation Space for AT&T's permitted use, until such Collocation Space is fully repaired and restored and AT&T's equipment installed therein (but in no event later than thirty (30) days after the Collocation Space is fully repaired and restored). Where AT&T has placed an Adjacent Arrangement pursuant to Section 3.4 of this Attachment 4, AT&T shall have the sole responsibility to repair or replace said Adjacent Arrangement provided herein. Pursuant to this section, BellSouth will restore the associated services to the Adjacent Arrangement.

14 EMINENT DOMAIN

- 14.1 If the whole of a Collocation Space or Adjacent Arrangement shall be taken by any public authority under the power of eminent domain, then this Attachment shall terminate only with respect to such taken Collocation Space or Adjacent Arrangement as of the day possession shall be taken by such public authority and rent and other charges for such taken Collocation Space or Adjacent Arrangement shall be paid up to that day with proportionate refund by BellSouth of such rent and charges as may have been paid in advance for a period subsequent to the date of the taking. If any part of the Collocation Space or Adjacent Arrangement shall be taken under eminent domain, BellSouth and AT&T shall each have the right to terminate this Attachment only with respect to such part of the Collocation Space or Adjacent Arrangement taken and declare the same null and void, by written notice of such intention to the other Party within ten (10) days after such taking.

15 RELOCATION OF AT&T'S EQUIPMENT

15.1 Except as otherwise stated in this Attachment, BellSouth shall use its best efforts to prevent AT&T from having to relocate its equipment during the term of this Agreement. If AT&T, at BellSouth's request, agrees to relocate its equipment, then BellSouth shall reimburse AT&T for any and all costs reasonably associated with such relocation.

16 NONEXCLUSIVITY

16.1 AT&T understands that this Attachment is not exclusive and that BellSouth may enter into similar agreements with other parties. Assignment of space pursuant to all such agreements shall be determined by space availability and made on a first come, first served basis in accordance with the procedures established in this Attachment of obtaining Collocation Space.

ENVIRONMENTAL AND SAFETY PRINCIPLES

The following principles provide basic guidance on environmental and safety issues when applying for and establishing Physical Collocation arrangements.

1. **GENERAL PRINCIPLES**

1.1 **Compliance with Applicable Law.** BellSouth and AT&T agree to comply with applicable federal, state, and local environmental and safety laws and regulations including U.S. Environmental Protection Agency (USEPA) regulations issued under the Clean Air Act (CAA), Clean Water Act (CWA), Resource Conservation and Recovery Act (RCRA), Comprehensive Environmental Response, Compensation and Liability Act (CERCLA), Superfund Amendments and Reauthorization Act (SARA), the Toxic Substances Control Act (TSCA), and OSHA regulations issued under the Occupational Safety and Health Act of 1970, as amended and NFPA and National Electrical Codes (NEC) and the NESC ("Applicable Laws"). Each Party shall notify the other if compliance inspections are conducted by regulatory agencies and/or citations are issued that relate to any aspect of this agreement.

1.2 **Notice.** BellSouth and AT&T shall provide notice to the other, including Material Safety Data Sheets (MSDSs), of known and recognized physical hazards or Hazardous Chemicals existing on site or brought on site. Each Party is required to provide specific notice for known potential Imminent Danger conditions. AT&T should contact 1-800-743-6737 for BellSouth MSDS sheets.

1.3 **Practices/Procedures.** BellSouth may make available additional environmental control procedures for AT&T to follow when working at a BellSouth Premises (See Section 2, below). These practices/procedures will represent the regular work practices required to be followed by the employees and contractors of BellSouth for environmental protection. AT&T will require its contractors, agents and others accessing the BellSouth Premises to comply with these practices. Section 2 lists the Environmental categories where BST practices should be followed by AT&T when operating in the BellSouth Premises.

1.4 **Environmental and Safety Inspections.** BellSouth reserves the right to inspect the AT&T space with proper notification. BellSouth reserves the right to stop any AT&T work operation that imposes Imminent Danger to the environment, employees or other persons in the area or Facility.

1.5 **Hazardous Materials Brought On Site.** Any hazardous materials brought into, used, stored or abandoned at the BellSouth Premises by AT&T are owned by AT&T. AT&T will indemnify BellSouth for claims, lawsuits or damages to persons or property caused by these materials. Without prior written BellSouth approval, no substantial new safety or environmental hazards can be created by AT&T or different hazardous materials used by AT&T at BellSouth Facility. AT&T must demonstrate adequate emergency response capabilities for its materials used or remaining at the BellSouth Facility.

1.6 Spills and Releases. When contamination is discovered at a BellSouth Premises, the party discovering the condition must notify BellSouth. All Spills or Releases of regulated materials will immediately be reported by AT&T to BellSouth.

1.7 Coordinated Environmental Plans and Permits. BellSouth and AT&T will coordinate plans, permits or information required to be submitted to government agencies, such as emergency response plans, spill prevention control and countermeasures (SPCC) plans and community reporting. If fees are associated with filing, BellSouth and AT&T will develop a cost sharing procedure. If BellSouth's permit or EPA identification number must be used, AT&T must comply with all of BellSouth's permit conditions and environmental processes, including environmental "best management practices (BMP)" (see Section 2, below) and/or selection of BST disposition vendors and disposal sites.

1.8 Environmental and Safety Indemnification. BellSouth and AT&T shall indemnify, defend and hold harmless the other party from and against any claims (including, without limitation, third-party claims for personal injury or death or real or personal property damage), judgments, damages, (including direct and indirect damages, and punitive damages), penalties, fines, forfeitures, costs, liabilities, interest and losses arising in connection with the violation or alleged violation of any Applicable Law or contractual obligation or the presence or alleged presence of contamination arising out of the acts or omissions of the indemnifying party, its agents, contractors, or employees concerning its operations at the Facility.

2. CATEGORIES FOR CONSIDERATION OF ENVIRONMENTAL ISSUES

When performing functions that fall under the following Environmental categories on BellSouth's Premises, AT&T agrees to comply with the applicable sections of the current issue of BellSouth's Environmental and Safety Methods and Procedures (M&Ps), incorporated herein by this reference. AT&T further agrees to cooperate with BellSouth to ensure that AT&T's employees, agents, and/or subcontractors are knowledgeable of and satisfy those provisions of BellSouth's Environmental M&Ps which apply to the specific Environmental function being performed by AT&T, its employees, agents and/or subcontractors.

The most current version of reference documentation must be requested from BellSouth.

2. **Categories for Consideration of Environmental Issues (cont.)**

ENVIRONMENTAL CATEGORIES	ENVIRONMENTAL ISSUES	ADDRESSED BY THE FOLLOWING DOCUMENTATION
Disposal of hazardous material or other regulated material (e.g., batteries, fluorescent tubes, solvents & cleaning materials)	Pollution liability insurance EVET approval of contractor	Std T&C 450 GU-BTEN-001BT, Chapter 4 Std T&C 660-3 GU-BTEN-001BT, Chapter 10
Emergency response	Hazmat/waste release/spill firesafety emergency	GU-BTEN-001BT, Chapter Building Emergency Operations Plan (EOP) (specific to Premises)
Contract labor/outsourcing for services with environmental implications to be performed on BellSouth Premises (e.g., disposition of hazardous material/waste; maintenance of storage tanks)	Performance of services in accordance with BST's environmental M&Ps Insurance	Std T&C 450 Std T&C 450-B (Contact E/S or your DEC/LDEC for copy of appropriate E/S M&Ps.) Std T&C 660
Transportation of hazardous material	Pollution liability insurance EVET approval of contractor	Std T&C 450 GU-BTEN-001BT, Chapter 4 Std T&C 660-3 GU-BTEN-001BT, Chapter 10
Maintenance/operations work which may produce a waste Other maintenance work	Protection of BST employees and equipment	Std T&C 450 GU-BTEN-001BT, Chapter 10 29CFR 1910.147 29CFR 1910 Subpart O
Janitorial services	All waste removal and disposal must conform to all applicable federal, state and local regulations All HazMat & Waste Asbestos notification protection of BST employees and equipment	P&SM Manager - Procurement GU-BTEN-001BT, Chapter 4, GU-BTEN-001BT, Chapter 3 BSP 010-170-001BS (Hazcom)

Manhole cleaning	Pollution liability insurance Manhole entry requirements EVET approval of contractor	Std T&C 450 Std T&C 660-3 BSP 620-145-011PR Issue A, August 1996 GU-BTEN-001BT, Chapter 10 RL9706008BT
Removing or disturbing building materials that may contain asbestos	Asbestos work practices	GU-BTEN-001BT, Chapter 3

3. DEFINITIONS

Generator. Under RCRA, the person whose act produces a Hazardous Waste, as defined in 40 CFR 261, or whose act first causes a Hazardous Waste to become subject to regulation. The Generator is legally responsible for the proper management and disposal of Hazardous Wastes in accordance with regulations.

Hazardous Chemical. As defined in the U.S. Occupational Safety and Health (OSHA) hazard communication standard (29 CFR 1910.1200), any chemical which is a health hazard or physical hazard.

Hazardous Waste. As defined in section 1004 of RCRA.

Imminent Danger. Any conditions or practices at a facility which are such that a danger exists which could reasonably be expected to cause immediate death or serious harm to people or immediate significant damage to the environment or natural resources.

Spill or Release. As defined in Section 101 of CERCLA.

4. ACRONYMS

DEC/LDEC - Department Environmental Coordinator/Local Department Environmental Coordinator

GU-BTEN-001BT - BellSouth Environmental Methods and Procedures

EVET - Environmental Vendor Evaluation Team

P&SM - Property & Services Management

Std. T&C - Standard Terms & Conditions

NESC - National Electrical Safety Codes

THREE MONTH CLEC FORECAST

CLEC NAME _____

DATE _____

STATE	Central Office/City	CAGED Sq. Ft.	CAGELESS # Bays		FRAME TERMINATIONS	CLEC Provided BDFB--Amps Load	BST Provided BDFB---Amps Load	Heat Dissipation BTU/Hour	Entrance Facilities # sheaths & # fibers	Proposed Application Date	NOTES
			Standard Bays*	Non- Standard Bays**							

*Standard bays are defined as racks, bays or cabinets, including equipment and cable, with measurements equal to or less than the following: Width - 26", Depth - 25". The standard height for all collocated equipment bays in BellSouth is 7' 0".

** Any forecast for non-standard cageless bays must include an attachment describing the quantity and width and depth measurements.

Notes: Forecast information will be used for no other purpose than collocation planning.
Forecast with application dates greater than 3 months from the date of submission will not guarantee the reservation of space in the office requested.

BELLSOUTH / ATT RATES
Collocation
Kentucky

CATEGORY	NOTE	RATE ELEMENT	Interim Indicator	Zone	BCS	USOC	RATES				OSS RATES						
							Nonrecurring		Nonrecurring Disconnect		Svc Order Submitted Elec per LSR	Svc Order Submitted Manually per LSR	Incremental Charge - Manual Svc Order vs. Electronic-1st	Incremental Charge - Manual Svc Order vs. Electronic-Add'l	Incremental Charge - Manual Svc Order vs. Electronic-Disc 1st	Incremental Charge - Manual Svc Order vs. Electronic-Disc Add'l	
							Rec	First	Add'l	First							Add'l
PHYSICAL COLLOCATION																	
		Physical Collocation - Application Fee - Initial			CLO	PE1BA		\$3,761.00		\$3,761.00							
		Physical Collocation - Application Fee - Subsequent			CLO	PE1CA		\$3,135.00		\$3,135.00							
		Physical Collocation - Space Preparation - Firm Order Processing			CLO	PE1SJ		\$1,202.00		\$1,202.00							
		Physical Collocation - Space Preparation - C.O. Modification per square ft.			CLO	PE1SK	\$2.38										
		Physical Collocation - Space Preparation - Common Systems Modification per square ft. - Cageless			CLO	PE1SL	\$3.30										
		Physical Collocation - Space Preparation - Common Systems Modification per Cage			CLO	PE1SM	\$112.11										
		Physical Collocation - Cable Installation			CLO	PE1BD		\$1,755.00		\$1,755.00							
		Physical Collocation - Floor Space per Sq. Ft.			CLO	PE1PJ	\$8.20										
		Physical Collocation - Cable Support Structure			CLO	PE1PM	\$20.14										
	Note 1	Physical Collocation - Power per Fused Amp			CLO	PE1PL	\$7.68	ICB		ICB							
	Note 1	Physical Collocation - Power per Fused Amp			CLO	XXXXX	\$8.77										
		Physical Collocation - 120V, Single Phase Standby Power Rate			CLO	PE1FB	\$5.58										
		Physical Collocation - 240V, Single Phase Standby Power Rate			CLO	PE1FD	\$11.16										
		Physical Collocation - 120V, Three Phase Standby Power Rate			CLO	PE1FE	\$16.74										
		Physical Collocation - 277V, Three Phase Standby Power Rate			CLO	PE1FG	\$38.65										
		Physical Collocation - 2-Wire Cross-Connects			UEANL,UEA,U DN,UDC,UAL,U HL,UCL,UEQ	PE1P2	\$0.037	\$33.67		\$31.78							
		Physical Collocation - 4-Wire Cross-Connects			CLO	PE1P4	\$0.075	\$33.66		\$31.70							
		Physical Collocation - DS1 Cross-Connects			CLO	PE1P1	\$1.51	\$52.97		\$39.90							
		Physical Collocation - DS3 Cross-Connects			CLO	PE1P3	\$19.15	\$52.04		\$38.62							
		Physical Collocation - 2-Fiber Cross-Connect			CLO	PE1F2	\$3.80	\$52.04		\$38.63							
		Physical Collocation - 4-Fiber Cross-Connect			CLO	PE1F4	\$6.75	\$64.59		\$51.18							
		Physical Collocation - Welded Wire Cage - First 100 Sq. Ft.			CLO	PE1BW	\$189.85										
		Physical Collocation - Welded Wire Cage - Add'l 50 Sq. Ft.			CLO	PE1CW	\$18.62										
		Physical Collocation - Security Access System - Security System per Central Office			CLO	PE1AX	\$78.11										
		Physical Collocation - Security Access System - New Access Card Activation, per Card			CLO	PE1A1	\$0.059	\$55.59		\$55.59							
		Physical Collocation-Security Access System-Administrative Change, existing Access Card, per Card			CLO	PE1AA	\$15.59		\$15.59								
		Physical Collocation - Security Access System - Replace Lost or Stolen Card, per Card			CLO	PE1AR	\$45.58		\$45.58								
		Physical Collocation - Security Access - Initial Key, per Key			CLO	PE1AK	\$26.20		\$26.20								
		Physical Collocation - Security Access - Key, Replace Lost or Stolen Key, per Key			CLO	PE1AL	\$26.20		\$26.20								
		Physical Collocation - Space Availability Report per premises			CLO	PE1SR	\$2,151.00		\$2,151.00								
		POT Bay Arrangements prior to 6/1/99 - 2-Wire Cross-Connect, per cross-connect			UEANL,CLO	PE1PE	\$0.06										
		POT Bay Arrangements prior to 6/1/99 - 4-Wire Cross-Connect, per cross-connect			CLO	PE1PF	\$0.15										
		POT Bay Arrangements prior to 6/1/99 - DS1 Cross-Connect, per cross-connect			CLO	PE1PG	\$0.58										
		POT Bay Arrangements prior to 6/1/99 - DS3 Cross-Connect, per cross-connect			CLO	PE1PH	\$4.51										
		POT Bay Arrangements prior to 6/1/99 - 2-Fiber Cross-Connect, per cross-connect			CLO	PE1B2	\$32.94										
		POT Bay Arrangements prior to 6/1/99 - 4-Fiber Cross-Connect, per cross-connect			CLO	PE1B4	\$44.42										
		Collocation Cable Records - per request *	I		CLO	PE1CR		\$1,709.00		\$1,166.00							
		Collocation Cable Records - VG/DS0 Cable, per cable record *	I		CLO	PR1CD		\$923.83		\$923.83							
		Collocation Cable Records - VG/DS0 Cable, per each 100 pair *	I		CLO	PE1CO		\$18.03		\$18.03							
		Collocation Cable Records - DS1, per T1TIE *	I		CLO	PE1C1		\$8.44		\$8.44							

BELLSOUTH / ATT RATES
Collocation
Kentucky

CATEGORY	NOTE	RATE ELEMENT	Interim Indicator	Zone	BCS	USOC	RATES				OSS RATES						
							Rec	Nonrecurring		Nonrecurring Disconnect		Svc Order Submitted Elec per LSR	Svc Order Submitted Manually per LSR	Incremental Charge - Manual Svc Order vs. Electronic-1st	Incremental Charge - Manual Svc Order vs. Electronic-Add'l	Incremental Charge - Manual Svc Order vs. Electronic-Dis 1st	Incremental Charge - Manual Svc Order vs. Electronic-Dis Add'l
								First	Add'l	First	Add'l						
		Collocation Cable Records - DS3, per T3TIE *	I		CLO	PE1C3	\$29.54	\$29.54									
		Collocation Cable Records - Fiber Cable, per cable record *	I		CLO	PE1CB	\$279.05	\$279.05									
		Physical Collocation - Security Escort - Basic, per Half Hour			CLO	PE1BT	\$33.86	\$21.46									
		Physical Collocation - Security Escort - Overtime, per Half Hour			CLO	PE1OT	\$44.10	\$27.72									
		Physical Collocation - Security Escort - Premium, per Half Hour			CLO	PE1PT	\$54.35	\$33.97									
	Note 2	Co-Carrier Cross-Connect															
		Fiber Cable Support Structure				PE1ES	\$0.06										
		Copper or Coaxial Cable Support Structure				PE1DS	\$0.03										
ADJACENT COLLOCATION																	
		Adjacent Collocation - Space Charge per Sq. Ft.			CLO	PE1JA	\$0.018										
		Adjacent Collocation - Electrical Facility Charge per Linear Ft.			CLO	PE1JC	\$6.01										
		Adjacent Collocation - 2-Wire Cross-Connects			CLO	PE1P2	\$0.037	\$33.67	\$31.78								
		Adjacent Collocation - 4-Wire Cross-Connects			UEA,UHL,U DL, UCL,CLO	PE1P4	\$0.075	\$33.66	\$31.70								
		Adjacent Collocation - DS1 Cross-Connects			USL,CLO	PE1P1	\$1.51	\$52.97	\$39.9								
		Adjacent Collocation - DS3 Cross-Connects			CLO	PE1P3	\$19.15	\$52.04	\$38.62								
		Adjacent Collocation - 2-Fiber Cross-Connect			CLO	PE1F2	\$3.8	\$52.04	\$38.63								
		Adjacent Collocation - 4-Fiber Cross-Connect			CLO	PE1F4	\$6.75	\$64.59	\$51.18								
		Adjacent Collocation - Application Fee			CLO	PE1JB		\$3,155.00									
		Adjacent Collocation - 120V, Single Phase Standby Power Rate per AC Breaker Amp			CLO	PE1FB	\$5.58										
		Adjacent Collocation - 240V, Single Phase Standby Power Rate per AC Breaker Amp			CLO	PE1FD	\$11.16										
		Adjacent Collocation - 120V, Three Phase Standby Power Rate per AC Breaker Amp			CLO	PE1FE	\$16.74										
		Adjacent Collocation - 277V, Three Phase Standby Power Rate per AC Breaker Amp			CLO	PE1FG	\$38.65										
	Note 1	-48V DC Power For arrangements in place prior to the effective date of this exhibit, the recurring charges, PE1PL as stated in this Exhibit 5 to the Agreement shall apply.															
		For arrangements or augments requested pursuant to this Agreement, the recurring charges XXXXX as stated in this Exhibit 5 shall apply															
	Note 2	Co-Carrier Cross-Connect.. For arrangements in place prior to the effective date of this exhibit, the recurring charges as stated in this Exhibit 5 shall apply															
	*	Interim rates which are subject to true-up.															

Attachment 5

**Access to Numbers
and
Number Portability**

TABLE OF CONTENTS

1 NON-DISCRIMINATORY ACCESS TO TELEPHONE NUMBERS 3

2 PERMANENT NUMBER PORTABILITY 3

3 SERVICE PROVIDER NUMBER PORTABILITY 7

4 SPNP IMPLEMENTATION 7

5 LERG REASSIGNMENT 12

6 RATES 12

7 TRANSITION TO PERMANENT NUMBER PORTABILITY..... 12

Exhibit A, The Local Number Portability Ordering Guide for CLECs

Exhibit B, Rates for Service Number Portability

ACCESS TO NUMBERS and NUMBER PORTABILITY

1 Non-Discriminatory Access to Telephone Numbers

- 1.1 During the term of this Agreement, AT&T shall contact NeuStar for the assignment of numbering resources. In order to be assigned a Central Office Code, AT&T will be required to complete the Central Office Code (NXX) Assignment Request and Confirmation Form (Code Request Form) in accordance with Industry Numbering Committee's Central Office Code (NXX) Assignment Guidelines (INC 95-0407-008).
- 1.2 For the purposes of the resale of BellSouth's telecommunications services by AT&T, BellSouth will provide AT&T with on line access to telephone numbers for reservation on a first come first served basis. Such reservations of telephone numbers, on a pre-ordering basis shall be for a period of nine (9) days. AT&T acknowledges that there may be instances where there is a shortage of telephone numbers in a particular Common Language Location Identifier Code ("CLLIC") and in such instances BellSouth may request that AT&T cancel all or a portion of its reservations of numbers. AT&T's consent to such request shall not be unreasonably withheld.
- 1.3 Further, upon AT&T request and for the purposes of the resale of BellSouth's telecommunications services by AT&T, BellSouth will reserve up to 100 telephone numbers per CLLIC, for AT&T's sole use. Such telephone number reservations shall be transmitted to AT&T via electronic file transfer. Such reservations shall be valid for ninety (90) days from the reservation date. AT&T acknowledges that there may be instances where there is a shortage of telephone numbers in a particular CLLIC and in such instances BellSouth shall use its best efforts to reserve for a ninety (90) day period a sufficient quantity for AT&T's reasonable need in that particular CLLIC.

2 Permanent Number Portability

- 2.1 The FCC, the Commissions and industry forums have developed a permanent approach to providing service provider number portability and BellSouth is working to implement Permanent Number Portability ("PNP"). Both Parties agree to implement a permanent approach as developed and approved by the Commission, the FCC and industry forums. Consistent with the requirements to move to PNP, interim Service Provider Number Portability ("SPNP") is available pursuant to Section 3 of this Attachment 5.

- 2.2 BellSouth and AT&T will adhere to the process flows and cutover guidelines outlined in "The Local Number Portability Ordering Guide for CLECs," Issue 1b, dated October 10, 1999, attached as Exhibit A to this Attachment 5.
- 2.2.1 BellSouth and AT&T will work cooperatively to implement changes to PNP process flows ordered by the FCC or as recommended by standard industry forums addressing PNP.
- 2.2.2 Both Parties shall cooperate in the process of porting numbers from one carrier to another so as to limit service outage for the ported subscriber. BellSouth will set LRN unconditional or 10-digit triggers where applicable which should ensure no interruption to the end user. Where triggers are set, BellSouth removes the ported number at the same time the trigger is removed.
- 2.2.3 For porting of numbers where triggers are not set, the Parties shall coordinate the porting of the number between service providers so as to minimize service interruptions to the end user.
- 2.2.4 BellSouth will provide ordering support for AT&T's PNP requests Monday through Friday 8:00 AM until 8:00 PM EST. BellSouth normal hours of operation for provisioning support are defined in Attachment 7, incorporated herein by this reference. Ordering and provisioning support required by AT&T outside of these hours will be considered outside of normal business hours and will be subject to overtime billing. For stand alone PNP where LRN unconditional or 10-digit triggers are set, AT&T may port numbers during times that are supported by NPAC 24 hours a day 7 days a week. BellSouth will provide maintenance assistance to AT&T 24 hours a day 7 days a week to resolve issues arising from the porting of numbers for problems isolated to the BellSouth network.
- 2.2.5 AT&T will provide ordering support for BellSouth's PNP requests Monday through Friday, 8:00 a.m. until 5:00 p.m. MST.
- 2.2.6 Performance Measurements for BellSouth providing PNP are located in Attachment 9 to this Agreement, incorporated herein by this reference.
- 2.3 BellSouth will use best efforts to update switch translations, where necessary, in time frames that are consistent with the time frames BellSouth's end users experiences or as offered to other CLECs.
- 2.4 AT&T may request deployment of PNP according to and pursuant to the rules and regulations set forth in 47 CFR § 52.23.

- 2.5 End User Line Charge. Recovery of charges associated with implementing PNP through a monthly charge assessed to end users has been authorized by the FCC. This end user line charge will be as filed in BellSouth's FCC Tariff No. 1 and will be billed to AT&T where AT&T is a subscriber to local switching or where AT&T is a reseller of BellSouth telecommunications services. This charge will not be discounted.
- 2.6 **LRN-LNP employs an "N-1" Query Methodology**
- 2.6.1 For interlata or intralata toll calls the originating carrier will pass the call to the appropriate toll carrier who will perform the LNP query. In this situation, the toll carrier is the N-1 carrier.
- 2.6.2 For a local call to a ported number, BellSouth or AT&T, as the originating carrier, will be the N-1 carrier. The N-1 carrier will perform an external database query and pass the call to the appropriate terminating carrier.
- 2.6.3 For local calls to an NXX in which at least one number has been ported via LRN-PNP, the Party that owns the originating switch shall query an LRN-PNP database as soon as the call reaches the first LRN-PNP-capable switch in the call path. The Party that owns the originating switch shall query on a local call to an NXX in which at least one number has been ported via LRN-PNP prior to any attempts to route the call to any other switch. Prior to the first number in an NXX being ported via LRN-PNP, neither Party will charge a query charge to the other Party when the other Party is the N-1 carrier.
- 2.6.4 A Party shall be charged for an LRN-PNP query by the other Party only if the Party to be charged is the N-1 carrier and it was obligated to perform the LRN-PNP query but failed to do so. Parties are not obligated to perform the LNP-PNP query prior to the first port in an NXX.
- 2.6.5 On calls originating from a Party's network, the Party will populate, in the SS7 Initial Address Message, if technically feasible, the Jurisdiction Information Parameter ("JIP") with the first six digits of the ten digit Location Routing Number ("LRN") in accordance with the applicable industry technical standards.
- 2.7 **SMS Administration**
- 2.7.1 AT&T and BellSouth will adhere to the Number Portability Administration Center ("NPAC") Service Management System ("SMS") Functional Requirements Specification ("FRS") as described in the NANC-FRS-Number Portability Administration Center-SMS,

Version 1.1, dated May 5, 1997, as required in FCC Order No. 97-289, released August 18, 1997, or as further required by the FCC in future proceedings.

2.8 **Project Management Guidelines for PNP**

2.8.1 BellSouth will project manage a PNP order from AT&T if it meets one or more of the following criteria:

- 51 + telephone numbers on basic service;
- 15 + loops;
- telephone numbers associated with a complex class of service.

2.8.2 As used herein, the term "Project Manage" means that the Parties shall negotiate implementation details, including but not limited to, due dates, cut-over intervals and times, coordination of technical resources and completion notices.

2.9 **Excluded Numbers**

2.9.1 Neither Party shall be required to provide number portability for excluded numbers (e.g., 500 and 900 NPAs, 950 and 976 NXX number services, and others as excluded by FCC rulings issued from time to time) under this Agreement.

2.10 **Mass Calling Numbers/Choke Networks**

2.10.1 Mass Call Numbers will not be ported with LRN (i.e., there will be no database queries made for mass call number NXX's associated with choke networks). Until the FCC has adopted a standard for porting mass call numbers, the Parties will work cooperatively with each other to direct calls to the mass calling network using arrangements that are economical and efficient for both Parties.

2.11 **Operator Services, Line Information Database ("LIDB") and Directory Assistance**

2.11.1 If Operator Services, LIDB and Directory Assistance services are provided pursuant to this Agreement, they shall also apply when PNP is in place.

2.12 If Integrated Services Digital Network User Part ("ISUP") signaling is used, BellSouth and AT&T shall provide, if technically feasible, the Jurisdiction Information Parameter ("JIP") in the SS7 Initial Address Message ("IAM") in accordance with applicable industry standard technical references.

2.13 **Porting of PNP DID Block Numbers**

BellSouth and AT&T shall offer number portability to customers for any portion of an existing DID block without being required to port the entire block of DID numbers. BellSouth and AT&T shall permit end users who port a portion of DID numbers to retain DID service on the remaining portion of the DID numbers. Porting a portion of a range of DID numbers can be provided by BellSouth pursuant to its General Subscriber Services Tariff. The lines remaining with BellSouth will be billed to BellSouth end users at the applicable tariffed rates or consistent with BellSouth pricing guidelines.

3 **Service Provider Number Portability**

3.1 Definition. Until the industry-wide permanent solution is implemented in an end office, BellSouth shall provide Service Provider Number Portability ("SPNP"). SPNP is an interim service arrangement whereby an end user who switches subscription of his local exchange service from BellSouth to a CLEC, or vice versa, is permitted to retain the use of his existing assigned telephone number, provided that the end user remains at the same location for his local exchange service or changes locations and service providers but stays within the same serving wire center of his existing number.

3.2 Methods of Providing Number Portability. SPNP is available on a per telephone number basis through either remote call forwarding ("SPNP-RCF"), LERG reassignments (SPNP-LERG), direct inward dialing trunks (SPNP-DID), or route indexing (SPNP-RI) at the election of the Party requesting SPNP.

4 **SPNP Implementation**

4.1 SPNP is available only where AT&T or BellSouth is currently providing, or will begin providing concurrent with provision of SPNP, basic local exchange service to the affected end user. SPNP for a particular telephone number is available only from the central office originally providing local exchange service to the end user. SPNP for a particular assigned telephone number will be disconnected when any end user, Commission, BellSouth, or CLEC initiated activity (e.g., a change in exchange boundaries) would normally result in a telephone number change had the end user retained his initial local exchange service.

4.2 Signaling Requirements. SS7 Signaling is required for the provision of SPNP services. SPNP-DID is available from BellSouth on a per DS0, DS1, or DS3 basis.

4.3 The calling party shall be responsible for payment of the applicable charges for sent-paid calls to the SPNP number. For collect, third-

party, or other operator-assisted non-sent paid calls to the ported telephone number, BellSouth or the CLEC shall be responsible for the payment of charges under the same terms and conditions for which the end user would have been liable for those charges. Either Party may request that the other block collect and third company non-sent paid calls to the SPNP-assigned telephone number. If a Party does not request blocking, the other Party will provide itemized local usage detail for the billing of non-sent paid calls an individual end user account level. The billable detail will be delivered to the requesting Party pursuant to the terms and conditions contained within Attachment 6, incorporated herein by this reference.

- 4.4 Each Party shall be responsible for obtaining authorization from the end user for the handling of the disconnection of the end user's service, the provision of new local service and the provision of SPNP services. Each Party shall be responsible for coordinating the provision of service with the other to assure that its switch is capable of accepting SPNP ported traffic. Each Party shall be responsible for providing equipment and facilities that are compatible with the other's service parameters, interfaces, equipment and facilities and shall be required to provide sufficient terminating facilities and services at the terminating end of an SPNP call to adequately handle all traffic to that location and shall be solely responsible to ensure that its facilities, equipment and services do not interfere with or impair any facility, equipment, or service of the other Party or any of its end users. In the event that either Party determines in its reasonable judgment that the other Party will likely impair or is impairing, or interfering with any equipment, facility or service or any of its end users, that Party may either refuse to provide SPNP service or may terminate SPNP service to the other Party after providing appropriate notice.
- 4.5 Each Party shall be responsible for providing an appropriate intercept announcement service for any telephone numbers subscribed to SPNP services for which it is not presently providing local exchange service or terminating to an end user. Where either Party chooses to disconnect or terminate any SPNP service, that Party shall be responsible for designating the preferred standard type of announcement to be provided.
- 4.6 Each Party shall be the other Party's single point of contact for all repair calls on behalf of each Party's end user. Each Party reserves the right to contact the other Party's customers if deemed necessary for maintenance purposes.
- 4.7 Neither Party shall be responsible for adverse effects on any service, facility or equipment from the use of SPNP services. End-to-end transmission characteristics may vary depending on the distance and

routing necessary to complete calls over SPNP facilities and the fact that another carrier is involved in the provisioning of service. Therefore, end-to-end transmission characteristics cannot be specified by either Party for such calls. Neither Party shall be responsible to the other if any necessary change in protection criteria or in any of the facilities, operation, or procedures of either renders any facilities provided by the other Party obsolete or renders necessary modification of the other Party's equipment.

- 4.8 For terminating IXC traffic ported to either Party which requires use of either Party's tandem switching, the tandem provider will bill the IXC tandem switching, the interconnection charge, and a portion of the transport, and the other Party will bill the IXC local switching, the carrier common line and a portion of the transport. If the tandem provider is unable to provide the necessary access records to permit the other Party to bill the IXC directly for terminating access to ported numbers, then the tandem provider will bill the IXC full terminating switched access charges at the tandem provider's rate and will compensate the other Party at the tandem Party's tariff rates. If an intraLATA toll call is delivered, the delivering Party will pay terminating access rates to the other Party. This subsection does not apply in cases where SPNP-DID is utilized for number portability.
- 4.9 If SPNP is deployed by either Party and prior to conversion to PNP:
- 4.9.1 If requested by either Party, the other Party shall provide Emergency Interrupt ("EI") trunks to the requesting Party's End Office for Busy Line Verification/Busy Line Interrupt ("BLV/BLI") call requests for lines that terminate at the requesting Party's End Office;
- 4.9.2 When a BLV/BLI request for a ported number is directed to one Party's operator and the query is not successful (i.e., the request yields an abnormal result), the operator shall confirm whether the number has been ported and shall direct the request to the appropriate operator;
- 4.9.3 BellSouth shall remove from its LIDB all existing BellSouth issued Telephone Line Number ("TLN")-based card numbers when a customer ports its number to the AT&T;
- 4.9.4 Where BellSouth has control of directory listings and/or directory assistance for NXX codes containing ported numbers, BellSouth shall process the requests for directory listings and Directory Assistance entries as specified by AT&T on the appropriate service request.
- 4.9.5 AT&T shall have the right to use the existing BellSouth 911 infrastructure for all 911 capabilities. With respect to 911 service associated with ported numbers under SPNP, the Parties agree that all

ported numbers will remain in the Public Service Answering Points ("PSAP") routing databases. When remote call forwarding ("RCF") is used, both the ported numbers and shadow numbers for a Party's ported subscribers shall be stored in PSAP databases. Either Party shall have the right to verify the accuracy of the information in the PSAP databases.

- 4.9.6 Cut-over intervals for SPNP provided to AT&T end users will be at parity with the intervals experienced by BellSouth end users, BellSouth itself, or any other CLEC, in accordance with the Performance Measurements in Attachment 9, incorporated herein by this reference.
- 4.10 SPNP-RCF, as contemplated by this Attachment 5, is a telecommunications service whereby a call dialed to an SPNP-RCF equipped telephone number is automatically forwarded to an assigned seven- or ten- digit telephone number within the local calling area as defined in BellSouth's General Subscriber Services Tariff. The forwarded-to number shall be specified by AT&T or BellSouth, as appropriate. The forwarding company will provide identification of the originating telephone number, via SS7 signaling, to the receiving Party. Identification of the originating telephone number to the SPNP-RCF end user cannot be guaranteed. SPNP-RCF provides a single call path for the forwarding of no more than one simultaneous call to the receiving Party's specified forwarded-to number. Additional call paths are available and rates are set forth in Exhibit B.
- 4.11 SPNP-DID service, as contemplated by this Attachment 5, provides trunk side access to end office switches for direct inward dialing to the other company's premises equipment from the telecommunications network to lines associated with the other company's switching equipment and must be provided on all trunks in a group arranged for inward service.
 - 4.11.1 A SPNP-DID trunk termination charge, provided with SS7 Signaling only, applies for each trunk voice grade equivalent. In addition, direct facilities are required from the end office where a ported number resides to the end office serving the ported end user customer. The rates for a switched local channel and switched dedicated transport apply as contained in BellSouth's Intrastate Access Services tariff, as said tariff is amended from time to time. Transport mileage will be calculated as the airline distance between the end office where the number is ported and the Point of Interface ("POI") using the V&H coordinate method.
 - 4.11.2 SPNP-DID must be established with a minimum configuration of two channels and one unassigned telephone number per switch, per arrangement for control purposes.

- 4.11.3 Transport facilities arranged for SPNP-DID may not be mixed with any other type of trunk group, with no outgoing calls placed over said facilities.
- 4.11.4 SPNP-DID will be provided only where such facilities are available and where the switching equipment of the ordering company is properly equipped.
- 4.11.5 Where SPNP-DID service is required from more than one wire center or from separate trunk groups within the same wire center, such service provided from each wire center or each trunk group within the same wire center shall be considered a separate service.
- 4.11.6 Only customer-dialed sent-paid calls will be completed to the first number of a SPNP-DID number group; however, there are no restrictions on calls completed to other numbers of a SPNP-DID number group.
- 4.11.7 Interface group arrangements provided for terminating the switched transport at the Party's terminal location are as set forth in BellSouth's Intrastate Access Services Tariff, § E6.1.3.A as amended from time to time.
- 4.11.8 BellSouth and AT&T shall offer number portability to customers for any portion of existing DID block without being required to port the entire block of DID numbers. BellSouth and AT&T shall permit end users who port a portion of DID numbers to retain DID service on the remaining portion of the DID numbers. Porting a portion of a range of DID numbers can be provided by BellSouth pursuant to its General Subscriber Services Tariff. The lines remaining with BellSouth will be billed to BellSouth's end users at the applicable tariffed rates or consistent with BellSouth pricing guidelines.
- 4.11.9 SPNP-DID is available from BellSouth on a per DS1 or DS3 basis. Where SPNP-DID is technically feasible and is provided on a DS1 or a DS3 basis, the applicable rates are set forth in Exhibit B to this Attachment 5.
- 4.12 **Route Indexing**
- 4.12.1 Route Indexing ("RI") may take two forms: Route Index-Portability Hub ("RI-PH") or Directory Number-Route Index ("DN-RI").
- 4.12.2 RI-PH will route a dialed call to the first Party's (Party A's) switch associated with the NXX of the dialed number. Party A's switch shall then insert a prefix onto the dialed number which identifies how the call is to be routed to the other Party (Party B) as the local service

provider. The prefixed dialed number is transmitted to Party A's tandem switch to which the Party B is connected. The prefix is removed by the operation of the tandem switch and the dialed number is routed to Party B's switch so the routing of the call can be completed by Party B.

4.12.3 DN-RI is a form of RI-PH that requires direct trunking from BellSouth's switch where the ported number was originally assigned to the AT&T switch where the number has been ported. The BellSouth switch shall send without a prefix the originally dialed number to AT&T's switch.

4.12.4 BellSouth shall provide RI-PH or DN-RI on an individual telephone number basis, as the other Party designates. Where technically feasible, AT&T may designate both methods so that calls to ported numbers are first directed to AT&T's switch over direct trunks but may overflow to tandem trunks if all trunks in the direct group are occupied.

4.12.5 For both RI-PH and DN-RI the trunks used may, at AT&T's option, be the same as those used for exchange of other local traffic with the other Party if technically feasible. At either Party's option, the trunks shall employ SS7 or in band signaling and may be one way or two way.

5 LERG Reassignment

5.1 BellSouth and AT&T will mutually agree, on a case by case basis, when an entire NXX is to be reassigned using LERG reassignment. Both parties will work cooperatively to coordinate and complete the transfer prior to the date on which LERG changes become effective using processes and intervals agreed to by both Parties.

6 Rates

6.1 Rates for SPNP are set out in Exhibit B to this Attachment 5, incorporated herein by this reference. If no rate is identified in this Agreement, the rate for the specific service or function will be negotiated by the Parties upon request by either Party.

6.2 Rates for the interfaces to access Operations Support Systems functions shall be as set forth in Exhibit B of Attachment 2, incorporated herein by this reference.

7 Transition to Permanent Number Portability

7.1 Once PNP is implemented in an end office, with advance written notice, both Parties must withdraw their SPNP offerings. The transition from existing SPNP arrangements to PNP shall occur within one hundred twenty (120) days from the date PNP is implemented in the

end office serving the telephone number. Neither Party shall charge the other Party for conversion from SPNP to PNP. The Parties shall comply with any SPNP/PNP transition processes established by the FCC and State commissions and appropriate industry number portability work groups.

Local Number Portability Ordering Guide for CLECs

Local Number Portability Ordering Guide for CLECs

Network & Carrier Services

Copyright

October 1999

© BellSouth Telecommunications

Contents

Subject	Page
Introduction	v
Purpose	v
Version Information	v
1. Introduction to Local Number Portability	1
1.1 Description of LNP	1
1.2 Network Provisioning for Local Number Portability	1
1.3 LNP Order Status	3
2. LNP Order Process Flows	5
2.1 High Level LNP Order Process Flow and Narrative	5
2.2 Detailed LNP Order Process Flow and Narrative	7
2.2.1 LNP Order Process - Port Out and Port Out with Loop	8
3. LNP Clarification and Supplement (SUP) LSR Process Flows	17
3.1 Detailed LNP Clarification Process Flow and Narrative	17
3.1.1 Clarification Process	17
3.2 Detailed Supplement (SUP) LSR Process Flow and Narrative	18
3.2.1 Supplement (SUP) LSR Change Process	19
4. Requirements for LNP Ordering	23
4.1 Requirements for LNP Ordering	23
4.2 Local Number Portability Rules	24
4.3 Required Forms	26
4.4 Minimum Required Fields for Faxed LNP Orders	28
4.4.1 LSR Minimal Required Fields for Faxed Orders (LNP Port-out With or Without Loop)	28
4.4.2 Faxed End User Information Form Fields	32
4.4.3 Faxed Number Portability Form Fields	33
4.4.4 Faxed Loop Service with Number Portability Form Fields	34
4.5 Complex LNP Orders	36
4.6 Faxed Loop Service with Number Portability Fields	36
4.7 Project Managed LNP Orders and Standard Intervals	37
5. Critical Success Factors for LNP Ordering	39
5.1 Pre-Order Information	39
5.2 LSR Order Forms for LNP	39
5.3 Supplemental LSRs	40
5.4 Clarifications	40
5.5 Standard Intervals	40
5.6 NPAC Communication	41

5.7	E911 Lock Down	41
6.	System Interfaces	43
6.1	Interface Options for Order Submission	43
6.2	System Interface Descriptions	43
7.	Frequently Asked Questions	47
7.1	General	47
7.2	Ordering Options	48
7.3	LSR Error Notices	48
7.4	Due Dates	49
7.5	NPAC Communication	49
8.	LNP Ordering Checklist	51
8.1	LNP Ordering Checklist	51
9.	Glossary of LNP Terms	53
9.1	Glossary of LNP Terms	53

Introduction

Purpose

This document contains information on Local Number Portability for CLECs interested in ordering this service from BellSouth. The Guide is intended to increase the CLEC's understanding of LNP Order Process at BellSouth; to provide guidelines for LSR completion; and to offer information on critical success factors for LSR submission.

This guide is intended to be used as a supplement to, not a replacement for, the **BellSouth Ordering Guide for CLECs** and the **LEO Implementation Guide**, which are available on-line through the BellSouth Interconnection website at: <http://www.interconnection.bellsouth.com/guides/guides.html>

Information resources reviewed for this guide include, but are not limited to:

- BellSouth CLEC Interconnections Web Site
- BellSouth Interconnection Services Ordering Guide for CLECs
- BellSouth LNP Documentation
- North American Numbering Council (NANC) Architecture and Administrative Plan for Local Number Portability
- North American Numbering Council (NANC) Inter-Service Provider LNP Operations Flows
- www.fcc.gov
- www.npac.com/home.htm
- www.ported.com

Version Information

Table A Revision History

Chapter	Action Request #	Date/Issue	Description
Various	N/A	October 1999/ 1b	General Revision
Various	N / A	April 2, 1999 / 1a	General Revisions
All	N / A	March, 1999 / 1	First Issue

1. Introduction to Local Number Portability

1.1 Description of LNP

Local Service Provider Portability

Local Number Portability (LNP) is a part of local competition that provides end users with the ability to retain their phone numbers when they change their Local Service Provider.

Phase	Description
Local Service Provider (SPP)	Allows customers to keep their current telephone number(s) if they chose to switch from their current Local Service Provider to another.

The Telecommunications Act of 1996 requires BellSouth to provide a mechanism for customers to retain their current telephone numbers when they change their Local Service Provider.

Orders of the FCC pursuant to the Telecommunications Act of 1996 provide deadlines for implementing Local Service Provider Portability (SPP) in the top 100 metropolitan areas in the United States. The BellSouth territory includes 21 of the top 100 metropolitan areas. To learn more about BellSouth's implementation schedule plan , please visit us at:

Note: http://g8058183.ga.bst.bls.com/ibu/files/infra_lnp/LNP/LNPtrack.xls

1.2 Network Provisioning for Local Number Portability

Interim Number Portability (INP) is a temporary solution for porting numbers which involves two telephone numbers to route calls to the serving wire center using one of the following methods:

- Remote Call Forwarding
- Direct Inward Dialing
- Route Index Hubbing

Local Number Portability (LNP) is the long range solution for Service Provider Portability (SPP) and includes the following characteristics:

- uses only one telephone number.
- requires significant network architecture hardware and software upgrades.
- uses the Advanced Intelligent Network (AIN).
- requires new routing methodology to send calls to the wire center of the company currently providing the local service.

Note: All calls to a port eligible NPA NXX will route using the AIN to look up the correct routing information (LRN) for the telephone number.

The **LNP Gateway (LNP GW)** is a major link in the LNP process for BellSouth since it provides both internal and external communications with various interfaces and processes, including:

- linking BellSouth to the Number Portability Administration Center (NPAC).
- allowing for inter-company communications between BellSouth and the CLECs for electronic ordering.
- providing interface between NPAC and AIN SMS for LNP routing processes.

The **Number Portability Administration Center (NPAC)** is a neutral third party organization that oversees the porting of telephone numbers for Local Number Portability. The NPAC maintains and communicates LNP-related data including

- Old Service Provider ID (OCN)
- New Service Provider ID (OCN)
- Local Routing Number (LRN)
- Due Dates
- CLASS-DPC
- CLASS-SSN
- LIDB-DPC
- LIDB-SSN
- CNAM-DPC
- CNAM-SSN
- ISVM-DPC
- ISVM-SSN

The BellSouth LNP Gateway must communicate with the NPAC as to whether numbers are porting out or porting in. The messages sent to and from the NPAC are called Subscription Versions (SVs). Subscription Versions are the messages that flow through the NPAC to provide information for routing calls to ported numbers. The SV can only contain one telephone number (TN), which means that one LSR may have many TNs and SVs associated with it.

LSRs for INP

LSRs requesting Interim Number Portability (INP) will not be accepted with due dates by BellSouth after the completion for each phase. If the due date is between ready to port and completion date, the CLEC may request INP or LNP.

1.3 LNP Order Status

Online Order Status Information For Faxed LSR's

CLEC PON Status Reports for faxed LNP LSRs are now available via BellSouth's website at <https://clec.bellsouth.com>. This report is located in the same location as your company's measurement reports. The information can be found as report number 00 (PON Report) on the CLEC reports page.

The report will provide status for all orders tracked into BellSouth's Local Order Number (LON) systems for the most recent 31 days. The report is CLEC specific. This will answer the majority of questions CLECs have about orders that have been submitted.

Each CLEC will be required to have a specific login and password to access these reports. The application for this report is also found on the web. Once the form is completed, it should be sent to the account team for processing.

EDI/TAG POS and CN

Users submitting LSR's through EDI or TAG receive Pending Order Statuses (POS) and Jeopardy Notifications back through the return path for these systems. Completion notification (CN) is sent when all service orders associated with the LSR are complete.

2. LNP Order Process Flows

2.1 High Level LNP Order Process Flow and Narrative

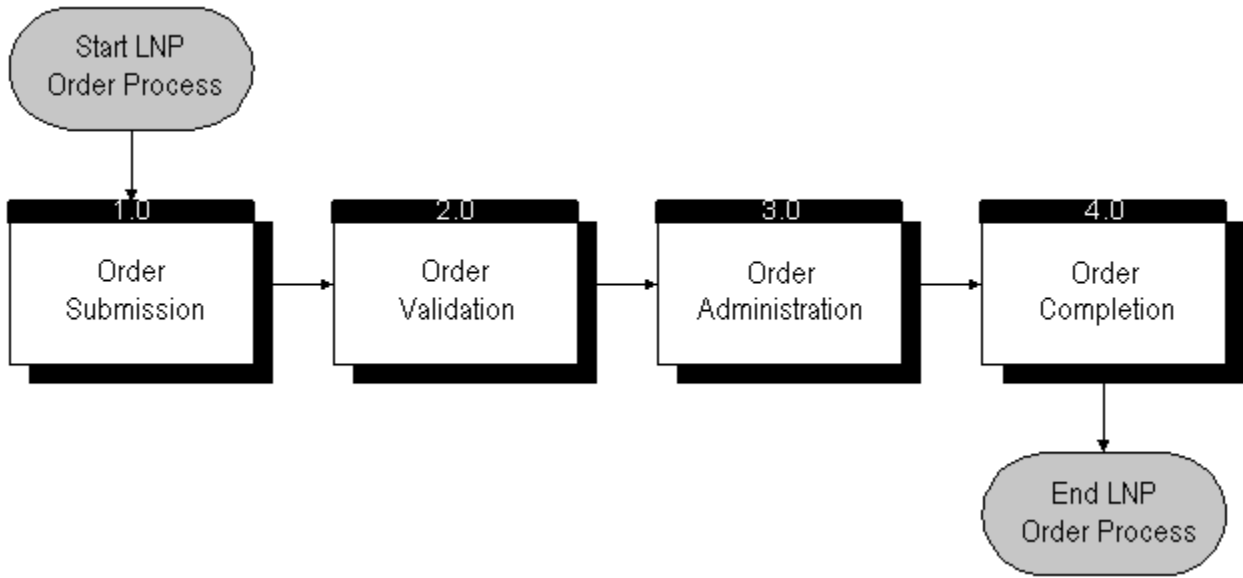

Figure 1 High Level LNP Order Process Flow

Step	Action
1.0 Order Submission:	CLEC sends LNP LSR to BellSouth LCSC via fax, EDI, or TAG.
2.0 Order Validation:	BellSouth validates CLEC LSR for errors, and requests clarification when necessary.

Step	Action
3.0 Order Administration:	BellSouth sends FOC to CLEC if clarification is not needed. CLEC receives FOC and immediately sends Create SV to NPAC. BellSouth then sends Concur SV to NPAC. The CLEC sends the Activate SV to NPAC on the Due Date, porting the number.
4.0 Order Completion:	BellSouth completes the Disconnect order and sends E911 Unlock message to SCC. CLEC sends E911 Migrate message to SCC.

2.2 Detailed LNP Order Process Flow and Narrative

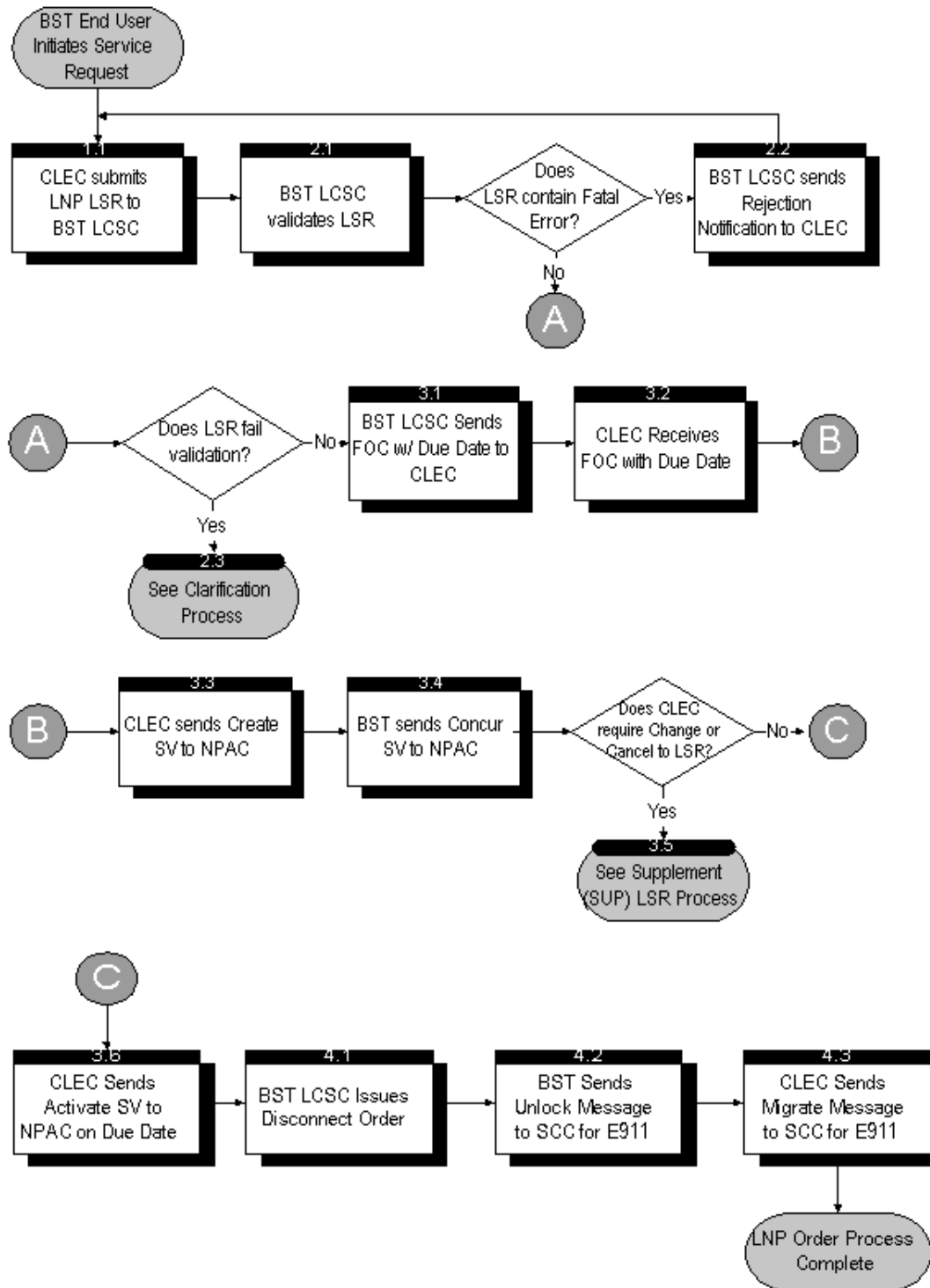

Figure 2 Detailed LNP Order Process Flow

2.2.1 LNP Order Process - Port Out and Port Out with Loop

1.0 Order Submission

1.1

Step	Action
Process Step	CLEC sends LNP LSR to BST LCSC via fax, EDI or TAG
Predecessor	Bell South End User initiates LNP Request with CLEC
Input	End-user CSR; BellSouth Ordering Guide for CLECs; order forms; BellSouth Standard Interval information; BellSouth LNP Ordering Checklist (Section 8.0 of BellSouth LNP Ordering Guide for CLECs)
Output	BellSouth LCSC receives paper copy LSR via fax server OR digital LSR for EDI or TAG orders
Key Interface	Fax; EDI; TAG
Notes	LSR format defined by OBF

2.0 Order Validation

2.1

Step	Action
Process Step	BST LCSC validates LSR
Predecessor	CLEC submission of LSR
Input	CLEC LSR
Output	Validated LSR

Step	Action
Key Interface	BellSouth LNP-Gateway
Notes	CLECs may access pre-order support using a web browser and the LENS interface. Use the Inquiry function to confirm the accuracy of customer record information, address, etc.
Decision Point	

Step	Action
Process Step	Does LSR contain Fatal Error*?
If YES:	Proceed to 2.2 "BST LCSC sends Rejection Notification to CLEC"
If NO:	Proceed to Decision Point "Does LSR fail validation?"
Notes	*Fatal Reject errors include missing required fields, duplicate PON, and invalid entries.

2.2

Step	Action
Process Step	BST LCSC sends Rejection Notification to CLEC
Predecessor	CLEC LNP LSR contains fatal errors (e.g., missing fields, duplicate PON, invalid entries)
Input	Rejected LSR
Output	Notification of fatal errors sent to CLEC
Key Interface	Fax, EDI, TAG, BellSouth LNP-Gateway
Notes	Fatal reject notices for EDI or TAG orders will be transmitted electronically via EDI or TAG. Fatal reject notices for faxed orders will be transmitted via fax.

Decision Point

Step	Action
Process Step	Does LSR fail validation?
If YES:	Proceed to 2.3 "Clarification Process"
If NO:	Proceed to 3.1 "BellSouth LCSC Sends FOC with Due Date to CLEC"
2.3	
See Clarification Process	
3.0 Order Administration	
3.1	

Step	Action
Process Step	BST LCSC Sends FOC with Due Date to CLEC
Predecessor	CLEC LSR passes BellSouth LNP Gateway validation.
Input	Valid LSR
Output	FOC is sent to CLEC via EDI, TAG, or fax; BellSouth LCSC issues 10 digit trigger order if applicable
Key Interface	EDI; TAG; fax; BellSouth LNP Gateway
Notes	"Trigger" may not be applicable for all types of service. See Local Number Portability Rules in section 4.0 for more details.

3.2

Step	Action
Process Step	CLEC receives FOC with Due Date
Predecessor	BellSouth LCSC sends CLEC FOC via fax, EDI, or TAG
Input	Valid LSR with FOC
Output	CLEC receives FOC with Due Date
Key Interface	Fax; EDI; TAG

3.3

Step	Action
Process Step	CLEC sends Create SV to NPAC with Due Date on FOC and Time set to 00:00
Predecessor	FOC received by CLEC
Input	FOC with Due Date sent by BellSouth LCSC
Output	NPAC notifies BellSouth LCSC that CLEC has sent Create SV
Key Interface	NPAC - Service Order Administration (SOA); BellSouth LNP Gateway
Notes	SV - Subscription Version BellSouth will place SVs in Conflict if CLEC sends the Create SV to NPAC prior to CLEC receiving FOC from BellSouth.

3.4

Step	Action
Process Step	BST LCSC sends Concur SV to NPAC with Due Date on FOC and Time set to 00:00
Predecessor	BellSouth receives notification of Create SV from NPAC
Input	Create SV sent by CLEC to NPAC
Output	NPAC notifies CLEC that Concur SV has been sent by BellSouth
Key Interface	NPAC - Service Order Administration (SOA); BellSouth LNP Gateway
Notes	BellSouth LCSC has <u>18 hours</u> after Create SV to send Concur SV to NPAC.
Decision Point	

Step	Action
Process Step	Does CLEC require Change* or Cancel to Original LSR?
If YES:	Proceed to 3.5 "Supplement (SUP) LSR Process"
If NO:	Proceed to 3.6 "CLEC sends Activate SV to NPAC with Due Date on FOC"
Notes	*Change to original LSR includes: Due Date change; Add/Remove TNs

3.5

See Supplement (SUP) LSR Process

3.6

Step	Action
Process Step	CLEC Sends Activate SV to NPAC on Due Date on FOC
Predecessor	BellSouth LCSC sends Concur SV to NPAC
Input	CLEC receives Concur SV from NPAC
Output	NPAC receives Activate SV from CLEC on Due Date on FOC
Key Interface	NPAC - Service Management System (SMS); BellSouth LNP Gateway
Notes	BellSouth is no longer responsible for customer after CLEC sends Activate SV to port the number. Activate SV should be sent for <u>all</u> telephone numbers on the LSR.

4.0 Order Completion

4.1

Step	Action
Process Step	BST LCSC Issues Disconnect Order
Predecessor	CLEC sends Activate SV to port number.
Input	NPAC notification of CLEC Activate SV sent to BellSouth
Output	Disconnect service orders issued by BellSouth LCSC

Step	Action
Key Interface	NPAC - Service Management System (SMS); BellSouth LNP Gateway
Notes	Following this point, questions regarding maintenance & repair should go to the UNE Center. LCSC will not issue disconnect until the Activate SV is received for <u>all</u> telephone numbers on LSR.
4.2	

Step	Action
Process Step	BST sends Unlock Message to SCC for E911
Predecessor	BellSouth completes Disconnect service order
Input	Disconnect service order
Output	SCC receives BellSouth's Unlock message
Key Interface	SCC
Notes	BellSouth will not send the Unlock message to SCC before the Disconnect service order is complete. BellSouth will not send the Unlock message for E911 until Activate SV is received for <u>all</u> telephone numbers on LSR.
4.3	

Step	Action
Process Step	CLEC Sends Migrate Message to SCC for E911
Predecessor	BellSouth Unlock message has been received by E911 SCC
Input	BellSouth Unlock message

Step	Action
Output	E911 record locked
Key Interface	SCC
Notes	If CLEC Migrate (Lock) message makes it to SCC before BellSouth's Unlock Message, then the CLEC message goes on an error report. BellSouth will not send Unlock message to SCC until CLEC has sent Activate SVs to NPAC for <u>all</u> telephone numbers on LSR.

3. LNP Clarification and Supplement (SUP) LSR Process Flows

3.1 Detailed LNP Clarification Process Flow and Narrative

Clarifications

Any LSR will be returned to the CLEC for clarification when BellSouth is not able to issue the orders requested due to:

- incomplete information
- incorrect information
- conflicting information

For faxed requests, clarifications will be sent via fax. Clarifications for EDI or TAG orders are sent via EDI or TAG. The CLEC has 10 business days to respond to the request for clarification by submitting a supplemental LSR. (SUP)* If no response is received, the LSR will be canceled on the eleventh day. If canceled by BellSouth, a new LSR (PON) must be submitted.

Note: * SUP LSRs must be sent using the same ordering method as the original LSR (i.e., Fax, EDI, TAG)

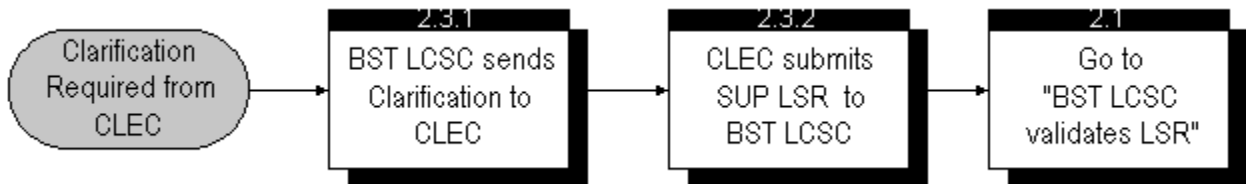

Figure 3 Detailed LNP Clarification Process Flow

3.1.1 Clarification Process

2.3.1

Step	Action
Process Step	BST LCSC sends Clarification to CLEC via Fax, EDI, or TAG
Predecessor	LSR falls out of BellSouth LNP-Gateway and requires clarification

Step	Action
Input	LSR rejected by BellSouth LNP-Gateway for clarification
Output	Clarification sent to CLEC via fax, EDI, or TAG
Key Interface	Fax; EDI; TAG

2.3.2

Step	Action
Process Step	CLEC submits SUP LSR via fax, EDI, or TAG to BST LCSC
Predecessor	LSR falls out of LNP-Gateway and requires clarification
Input	Clarification sent by LCSC via fax, EDI, or TAG to CLEC
Output	SUP LSR sent to LCSC
Key Interface	Fax; EDI; TAG
Notes	SUP must be sent via the same channel (EDI, TAG or fax) as the original LSR.

2.1
Go to "BST LCSC validates LSR"

3.2 Detailed Supplement (SUP) LSR Process Flow and Narrative

Supplement (SUP) LSR

A supplemental change (SUP) LSR will be required if a CLEC:

- has been asked for clarification on an LNP LSR,
- is requesting a Due Date Change,

- would like to cancel an LSR,
- would like to add/remove telephone numbers for porting on LSR.

If a CLEC is changing the original LSR, a SUP LSR must be filed with BellSouth prior to any contact with NPAC.

Note: SUP LSRs must be sent using the same ordering method as the original LSR (i.e., Fax, EDI, TAG)

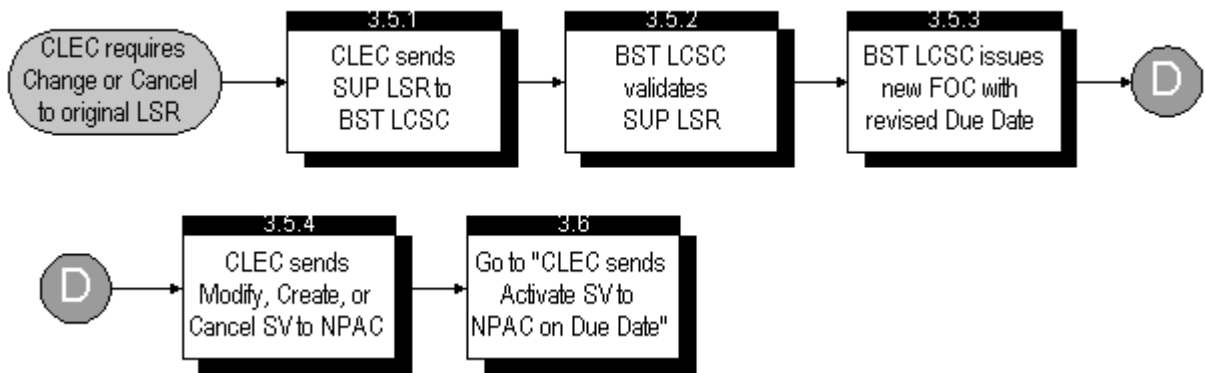

Figure 4 Detailed Supplement (SUP) LSR Process Flow

3.2.1 Supplement (SUP) LSR Change Process

3.5.1

Step	Action
Process Step	CLEC sends SUP LSR to BST LCSC
Predecessor	Create and Concur SV received by NPAC for original LSR
Input	Original FOC and LSR; SUP LSR
Output	BST LCSC receives SUP LSR via fax, EDI, or TAG

Step	Action
Key Interface	EDI; TAG; Fax
Notes	SUP LSR must be sent to BellSouth LCSC and revised FOC received by CLEC prior to CLEC sending Modify SV to NPAC. CLEC must complete SUP field and VER field on LSR form.

3.5.2

Step	Action
Process Step	BST LCSC validates SUP LSR
Predecessor	CLEC submission of SUP LSR
Input	CLEC SUP LSR
Output	Validated SUP LSR; BellSouth updates internal records with supplemental information on LSR
Key Interface	BellSouth LNP-Gateway

3.5.3

Step	Action
Process Step	
Predecessor	BellSouth receives and validates SUP LSR from CLEC
Input	SUP LSR; original LSR and FOC
Output	BellSouth LCSC updates internal records with new Due Date; new FOC sent to CLEC via fax, EDI, or TAG

Step	Action
Key Interface	BST LNP-Gateway; EDI; TAG; fax
Notes	CLEC must receive FOC prior to sending Modify SV to NPAC Revised Due Date on FOC will be based on the receipt of SUP LSR and the BST Standard Intervals.
3.4	

Step	Action
Process Step	CLEC sends Modify, Create or Cancel SV to NPAC
Predecessor	CLEC receives revised FOC with new Due Date
Input	SUP LSR; Revised FOC with new Due Date
Output	NPAC receives Modify, Create, or Cancel SV
Key Interface	NPAC - Service Order Administration (SOA)
Notes	If changing the Due Date on LSR, CLEC sends a Modify SV If removing TNs to port from original LSR, CLEC sends a Cancel SV for each TN. If adding TNs for porting, CLEC sends Create SVs for each new TN on the SUP LSR. If canceling the original LSR, CLEC sends Cancel SV to NPAC.

3.6

Go to "CLEC Sends Activate SV to NPAC on Due Date"

4. Requirements for LNP Ordering

4.1 Requirements for LNP Ordering

A telephone number may port out when all of the following are true:

- NPA NXX is portable.
- telephone number is a working number or end user is paying to reserve the number.
- end user name on the LSR matches the BellSouth customer record.
- end user address on the LSR is in the same Toll Message Rate Center (TMRC) as the address on the BellSouth customer record.
- number is associated with a line type that is portable. (Refer to Local Number Portability Rules - Section 4.2 below to determine if service type is portable and if a trigger order is necessary)

The responsibilities for porting out telephone numbers are described in the following table.

Table B The responsibilities for porting out telephone numbers are described in the following table

Work Group	Responsibilities
CLEC	<ul style="list-style-type: none"> • Send LSR to BellSouth to request number(s) to be ported. • Receives FOC before sending SVs to NPAC. • Provide service to end user. • Notify the NPAC when ready to port the number. • Update E911 information. • Send SUP LSR to change Due Date, Cancel LSR, or modify TN on LSR.
LCSC	<ul style="list-style-type: none"> • Process LSR and FOC for port out requests. • Issue trigger/port out/listing/loop service orders. • Send and receive NPAC messages.
UNE Center	<ul style="list-style-type: none"> • Coordinate port out with loop orders with CLEC as needed. • Complete port out with loop orders as needed. <p>Note: UNE Center is involved in provisioning only if loop is requested.</p>

4.2 Local Number Portability Rules

The following table may be used to determine if the service type is portable and if a trigger order is required. The existing service or line type is for reference only because the service is not portable. Only the number is ported.

Table C Local Number Portability Rules

Service / Line Type	Portable - w/ LRN	Trigger	Notes
AdWatch	Y	N	The number will no longer work for AdWatch once it is Ported.
Choke Codes	N		Does not involve LRN

Table C Local Number Portability Rules (continued)

Service / Line Type	Portable - w/ LRN	Trigger	Notes
Denied for Non-Pay	Y	N	
DID (Block of 20)	Y	N	To Port a portion of a range will require special assembly.
ESSX / MultiServ	Y	Y	If lines are in a hunting arrangement, see hunting Lines below.
FX / FCO	Y	Y	The number can be ported within the same Toll Message Rate Center (TMRC). The BST designed circuit will be disconnected and the new service provider must establish the service.
Hunting Lines	Y	Y	If not all of the numbers in the hunt group are porting, the numbers porting must be removed from the hunt group the day before the port due date. CLEC can determine Frame Due Time or use BST default of 9:00 PM day before Port.
ISDN	Y	Y	
N11	N		
Out dial trunks	Y	N	
Party Line	Y	N	The number may be ported without loop. The BST service must be disconnected
Remote Call Forwarding / Interim Number Portability	Y	N	
Reserved numbers	Y	N	Only numbers reserved with chargeable USOCs may be ported
RingMaster	Y	N	
Sub-Let	Y	Y	
Surrogate Client Number	Y	N	
Suspend for season	Y	N	
Uniserve	N		

- continued -

Table C Local Number Portability Rules (continued)

Service / Line Type	Portable - w/ LRN	Trigger	Notes
Warm Line	N		
ZipCONNECT	N		

4.3 Required Forms

Required Forms for Port Out

The CLEC submits the following forms to the LCSC to request telephone numbers to Port Out:

- Local Service Request (LSR)
- End User (EU)
- Number Portability (NP) or Loop Service with Number Portability (LSNP)

Conditional Forms for Porting Out

- Directory Listing Request (DLR)

If listings are required, the Directory Listing Request (DLR) will be needed unless the ACT code is **W**. The **W** ACT code is a switch as is for listings and directory delivery requirements. This activity code is only valid when porting out all numbers on an account. Without a **W** ACT code on a full port, all listings are deleted unless the CLEC submits a DLR.

LNP Order Form Matrix

Table D LNP Order Form Matrix

When Ordering:	These Forms Are:				
	LSR	EU	NP	LSNP	DLR
Number Portability	R	R	R	P	C*
Loop Service with Number Portability	R	R	P	R	C*

Form Names:	Form Requirements:
LSR = Local Service Request Form	R=Required
EU = End User Form	P=Prohibited
NP = Number Portability Form	C=Conditional

- continued -

LSNP = Loop Service with Number Portability Form	O=Optional
DLR = Directory Listing Request Form	

* If all the telephone numbers for the Account are converting (Full Migration) and no change is being made to the listing, the DLR is not required. (This requires an ACT code of **W**.) However, if only a portion of the lines on the account are converting (Partial Migration), the DLR should be submitted to request listings. A DLR is **not required** when associated with LNP (Local Number Portability), even for partial migration. However, directory listings or directory delivery will not be established without a DLR.

Required Forms for SUPs

A supplemental change (SUP) LSR will be required if a CLEC:

- has been asked for clarification on an LNP LSR,
- is requesting a Due Date Change,
- would like to cancel an LSR,
- would like to add/remove telephone numbers for porting on LSR.

Use the **LNP Order Matrix Form** above to determine which order forms must be used.

A supplemental change LSR (SUP) should contain complete information and will supersede the original LSR. The SUP must reflect the same PON and CC from the original request. It must also have a higher version number in the VER field. The SUP field must be populated with:

- (1) to Cancel. (Prohibited if CLEC has sent Activate SV to NPAC for any numbers on the LSR)
- (2) for Desired Due Date changes. The new date is specified in the DDD field. If the request is to establish a due date less than the standard interval (from the date the SUP is sent), the EXP field must also be populated.
- (3) for other types of changes. This includes adding or removing porting numbers. Also includes requests for a change in desired due date in conjunction with other changes to a pending order. The standard interval should be used to establish a new due date when adding or removing ported numbers.

EDI, TAG and Fax requests may not be combined for the same PON. If an LSR is submitted via:

- EDI all SUPs for the PON must be sent through EDI.
- Fax all SUPs for the PON must be faxed.
- TAG all SUPs for the PON must be sent through TAG.

4.4 Minimum Required Fields for Faxed LNP Orders

Minimal Required Fields on the Faxed LSR for LNP

Please review the notes for each field, as they may highlight common errors on LNP LSRs. The fields below are those required for LNP orders. They may be required, conditional, or optional for other types of orders.

4.4.1 LSR Minimal Required Fields for Faxed Orders (LNP Port-out With or Without Loop)

Table E LSR Minimal Required Fields for Faxed Orders (LNP Port-out With or Without Loop)

Field Abbreviation	Field Name	Explanation
CCNA	Customer Carrier Name Abbreviation	Refer to CLEC Order Guide 9.1.2.1 Note: Required for orders with loop.
PON	Purchase Order Number	Refer to CLEC Ordering Guide 9.1.2.2 Note: Every new request requires a unique PON number. Note: When issuing a SUP, the same PON number on the original LSR should be used; however, the (VER) must be different.
VER	Version Identification	Refer to CLEC Ordering Guide 9.1.2.3 Note: This field is conditional. When submitting a supplement (SUP) LSR, the CLEC must populate this field to uniquely distinguish this LSR from any other version. Note: If VER is entered, CLEC must also complete SUP field.
SC	Service Center	Refer to CLEC Ordering Guide 9.1.2.7
PG__OF__	Page number / Total pages	Refer to CLEC Ordering Guide 9.1.2.8
D / TSENT	Date and Time Sent	Refer to CLEC Ordering Guide 9.1.2.9

- continued -

Table E LSR Minimal Required Fields for Faxed Orders (LNP Port-out With or Without Loop) (continued)

Field Abbreviation	Field Name	Explanation
DDD	Desired Due Date	Refer to CLEC ordering guide 9.1.2.10 Note: Reference BST Standard Intervals for LNP when completing this field.
DFDT	Desired Frame Due Time	Refer to CLEC Ordering guide 9.1.2.14
REQTYP	Requisition Type and Status	Refer to CLEC Ordering Guide 9.1.2.17 Note: LNP with loop, will always be BB . LNP without loop, will always be CB
ACT	Activity	Refer to CLEC Ordering Guide 9.1.2.18. Note: Will be V to indicate conversion to another local service provider or C for INP to LNP conversion or W for Conversion Listing as Is (LNP Full Migrations Only)
SUP	Supplement Type	Refer to CLEC Ordering Guide 9.1.2.19 Note: This field is conditional. When submitting a supplement (SUP) LSR, this field must be populated.
CC	Company Code	Refer to CLEC Ordering Guide 9.1.2.23 Note: This code must be the code used for the NPAC and for CLEC Q-accounts. The CC is also known as the four digit OPERATING COMPANY NUMBER (OCN)
ACTL	Access Customer Terminal Location	Refer to CLEC Ordering Guide 9.1.2.30 Note: Required for orders with designed loop.
LSO	Local Service Office	Refer to CLEC Ordering Guide 9.1.2.34 Note: Required for loop orders or when a directory listing is requested on the end user telephone number which is from a CLEC assigned NPA NXX.

- continued -

Table E LSR Minimal Required Fields for Faxed Orders (LNP Port-out With or Without Loop) (continued)

Field Abbreviation	Field Name	Explanation
TOS	Type of Service	Refer to CLEC Ordering Guide 9.1.2.35 Note: Identifies type of service (business, residential, or government) for the existing account which is porting out. Note: Be sure to use D as the second character for Complex service.
NC	Network Channel	Refer to CLEC Ordering Guide 9.1.2.37 Note: Required for loop orders.
NCI	Network Channel Interface	Refer to CLEC Ordering Guide 9.1.2.38 Note: Required for designed loop orders.
SECNCI	Secondary Network Channel Interface	Refer to CLEC Ordering Guide 9.1.2.40 Note: Required for designed loop orders.
CIC	Carrier Identification Code	Refer to CLEC Ordering Guide 9.1.2.48
CUST	Customer Name	Refer to CLEC Ordering Guide 9.1.2.49
BAN1	Billing Account Number 1	Refer to CLEC Ordering Guide 9.1.2.51
ACNA	Access Customer Name Abbreviation	Refer to CLEC Ordering Guide 9.1.2.54 Note: Required for orders with loop.
TE	Tax Exemption	Generated by BST
INIT	Initiator Identification	Refer to CLEC Ordering Guide 9.1.2.69
TEL NO (INIT)	Telephone Number	Refer to CLEC Ordering Guide 9.1.2.70
FAX NO	Initiator Fax Number	Refer to CLEC Ordering Guide 9.1.2.72 Note: Required to send FOC via fax
STREET	Initiator Street Address	Refer to CLEC Ordering Guide 9.1.2.73
CITY	City	Refer to CLEC Ordering Guide 9.1.2.76

- continued -

Table E LSR Minimal Required Fields for Faxed Orders (LNP Port-out With or Without Loop) (continued)

Field Abbreviation	Field Name	Explanation
STATE	State	Refer to CLEC Ordering Guide 9.1.2.77
ZIPCODE	Zip Code	Refer to CLEC Ordering Guide 9.1.2.78
MPCON	Implementation Contact	Refer to CLEC Ordering Guide 9.1.2.79 Note: : Required for orders with loop and for ACT of V (indicates conversion to another local service provider)
TEL NO	Telephone Number	Refer to CLEC Ordering Guide 9.1.2.80 Note: Required for orders with loop and for ACT of V (indicates conversion to another local service provider)
DRC	Design Routing Code	Refer to CLEC Ordering Guide 9.1.2.86 Note: Required on orders with non-designed loop when requesting a Loop Make-up.

Critical Fields on LSR

There are certain critical fields on the LSR that cannot be changed once the LSR has been validated. If these fields are to be changed, the first LSR must be canceled and a new LSR issued on a different PON. The critical fields are:

- PON
- CC
- ATN
- AN
- EATN
- EAN
- ACT
- NPT

4.4.2 Faxed End User Information Form Fields

Please review the notes for each field, as they may highlight common errors on LNP LSRs. The fields below are those required for LNP orders. They may be required, conditional, or optional for other types of orders

Table F Minimal Required Fields for Faxed End User Form

Field Abbreviations	Field Name	Explanation
PON	Purchase Order Number	Refer to CLEC Ordering Guide 9.2.2.1 Note: This entry must be identical to the PON entry on the LSR form.
VER	Version Identification	Refer to CLEC Ordering Guide 9.2.2.2 Note: This field is conditional. When submitting a supplement (SUP) LSR, this entry must be identical to VER entry on the SUP LSR.
PG__OF__	Page Number / Total Pages	Refer to CLEC Ordering Guide 9.2.2.6
NAME	End User Name	Refer to CLEC Ordering Guide 9.2.3.1
SANO*	Service Address House Number	Refer to CLEC Ordering Guide 9.2.3.4
SASN	Service Address Street Name	Refer to CLEC Ordering Guide 9.2.3.7
CITY	City	Refer to CLEC Ordering Guide 9.2.3.14
STATE	State / Province	Refer to CLEC Ordering Guide 9.2.3.15
ZIP CODE	Zip Code	Refer to CLEC Ordering Guide 9.2.3.16

Note: Depending on the address associated with the order, conditional address fields may be required to provide a complete and valid end user location.

Note: The CLEC must advise BellSouth how to handle additional telephone numbers on the end user account. The additional telephone numbers may be associated with features such as:

- Ringmaster
- Surrogate Client MemoryCall
- Flexible Call Forwarding Dial Around (FCPAN)

If these telephone numbers are not porting, use the disconnect section on the End User Form to detail this information.

4.4.3 Faxed Number Portability Form Fields

Faxed Number Portability Form Fields

Note: The PS Form must always be associated with the Local Service Request (LSR) and End User (EU) forms. Please review the notes for each field, as they may highlight common errors on LNP LSRs. The fields below are those required for LNP orders. They may be required, conditional, or optional for other types of orders.

Table G Minimal Required Fields for the Faxed Number Portability Form

Field Abbreviation	Field Name	Explanation
PON	Purchase Order Number	Refer to CLEC Ordering Guide 9.8.2.1 Note: This entry must be identical to the PON entry on the LSR form.
VER	Version Identification	Refer to CLEC Ordering Guide 9.8.2.2 Note: This field is conditional. When submitting a supplement (SUP) LSR, this entry must be identical to VER entry on the SUP LSR.
NPQTY	Number Portability Quantity	Refer to CLEC Ordering Guide 9.8.2.5
PG__OF__	Page Number / Total Pages	Refer to CLEC Ordering Guide 9.8.2.6
REF NUM	Reference Number	Refer to CLEC Ordering Guide 9.8.3.1 Note: REF NUMs must be unique on each form associated with the LSR. REF NUMs may not be duplicated and are associated with porting numbers, disconnecting numbers, and directory listings.

- continued -

**Table G Minimal Required Fields for the Faxed Number Portability Form
(continued)**

Field Abbreviation	Field Name	Explanation
LNA	Line Activity	Refer to CLEC Ordering Guide 9.8.3.3 Note: V= conversion of service to new LSP C= change existing account (e.g. INP to LNP)
PORTED #	Ported Telephone Number	Refer to CLEC Ordering Guide 9.8.3.7
NPT	Number Portability Type	Refer to CLEC Ordering Guide 9.8.3.10 Note: D= Local Number Portability

4.4.4 Faxed Loop Service with Number Portability Form Fields

Faxed Loop Service with Number Portability Form Fields

Note: The LSNP form must always be associated with the Local Service Request (LSR) and End User (EU) forms. Please review the notes for each field, as they may highlight common errors on LNP LSRs. The fields below are those required for LNP orders. They may be required, conditional, or optional for other types of orders.

Table H Minimal Required Fields for Faxed Loop Service with Number Portability Form

Field	Abbreviation Field	Name Explanation
PON	Purchase Order Number	Refer to CLEC Ordering Guide 9.10.2.1 Note: This entry must be identical to the PON entry on the LSR form.
VER	Version Identification	Refer to CLEC Ordering Guide 9.10.2.2 Note: This field is conditional. When submitting a supplement (SUP) LSR, this entry must be identical to VER entry on the SUP LSR.
LQTY	Loop Quantity	Refer to CLEC Ordering Guide 9.10.2.5
PG__OF__	Page Number / Total Pages	Refer to CLEC Ordering Guide 9.10.2.6

- continued -

Table H Minimal Required Fields for Faxed Loop Service with Number Portability Form (continued)

Field	Abbreviation Field	Name Explanation
REF NUM	Reference Number	Refer to CLEC Ordering Guide 9.10.3.1 Note: For LNP, REF NUMs must be unique on each form associated with the LSR. REF NUMs may not be duplicated and are associated with porting numbers, disconnecting numbers, and directory listings.
LNA	Line Activity	Refer to CLEC Ordering Guide 9.10.3.3 Note: V= conversion of service to new LSP
SYSTEM ID	System Identification	Refer to CLEC Ordering Guide 9.10.3.8
CABLE ID	Cable Identification	Refer to CLEC Ordering Guide 9.10.3.11 Note: Required for port-out with loop orders. Note: Note: In some wire centers, CFA (Connecting Facility Assignment) may be used instead of cable ID and chain/pair. Refer to CLEC Ordering Guide 9.10.3.9
SHELF		Refer to CLEC Ordering Guide 9.10.3.12
SLOT		Refer to CLEC Ordering Guide 9.10.3.13
RELAY RACK		Refer to CLEC Ordering Guide 9.10.3.14

- continued -

Table H Minimal Required Fields for Faxed Loop Service with Number Portability Form (continued)

Field	Abbreviation Field	Name Explanation
CHAN / PAIR	Channel / Pair	Refer to CLEC Ordering Guide 9.10.3.15 Note: Identifies the customer's system to be used in a collocation arrangement. Required when the customer has assignment control in a collocation arrangement, otherwise prohibited. Note: Required for port-out with loop orders. In some wire centers, CFA (Connecting Facility Assignment) may be used instead of cable ID and chain/pair. Refer to CLEC Ordering Guide 9.10.3.9
PORTED #	Ported Telephone Number	Refer to CLEC Ordering Guide 9.10.3.23
NPT	Number Portability Type	Refer to CLEC Ordering Guide 9.10.3.26 Note: D= Local Number Portability

4.5 Complex LNP Orders

Definition of Complex Services

The Local Number Portability (LNP) request is classified as complex if the number(s) being ported out is working on a complex class of service. Requests to port out telephone numbers working on the following types of service are considered complex:

- ESSEX / MultiServ
- Primary Rate ISDN
- Basic Rate ISDN
- Channelized Megalink
- PBX - DID, Inward/Outward/Combination trunks
- Pathlink

4.6 Faxed Loop Service with Number Portability Fields

Faxed Loop Service with Number Portability Fields

Note: The LSNP form must always be associated with the Local Service Request (LSR) and End User (EU) forms. Please review the notes for each field, as they may highlight common errors on LNP LSRs. The fields below are those required for LNP orders. They may be required, conditional, or optional for other types of orders.

Field	Abbreviation Field	Name Explanantion
PON	Purchase Order Number	Refer to CLEC Ordering Guide 9.10.2.1 Note: This entry must be identical to the PON entry on the LSR form.
VER	Version Identification	Refer to CLEC Ordering Guide 9.10.2.2 Note: This field is conditional. When submitting a supplement (SUP) LSR, this enbtry must be identical to VER entry on the SUP LSR.
LQTY	Loop Quantity	Refer to CLEC Ordering Guide 9.10.2.5
PG_OF_	Page Number/Total Pages	Refer to CLEC Ordering Guide 9.10.2.6
REF NUM	Reference Number	Refer to CLEC Ordering Guide 9.10.3.1 Note: For LNP, REF Nums must be unique on each form associated with porting numbers, and directory listings.
LNA	Line Activity	Refer to CLEC Ordering Guide 9.10.3.3 Note: V= conversion of service to new LSP N= new loop
System ID	System Identification	Refer to CLEC Ordering Guide 9.10.3.8

4.7 Project Managed LNP Orders and Standard Intervals

Note: For information on project management and due date inetrvals, refer to BellSouth Products and Services Interval Guide Interconnection Services @ http://interconnection.bellsouth.com/guides/guides_html

5. Critical Success Factors for LNP Ordering

5.1 Pre-Order Information

1. CLEC can proactively check the following points in the LSR before submitting via fax, EDI, or TAG.
 - a. Customer address is RSAG valid and within the rate center;
 - b. NPA-NXX is marked portable in the LERG;
 - c. TNs on LSR match TNs on end user account;
 - d. Due Date intervals are based on BellSouth Standard Intervals.
2. CLEC must have a Q-account for each OCN registered with NPAC and stated on LSR. All new OCNs registered with NPAC should be updated with BellSouth and a Q-account should be established.
3. CLEC should use correct OCN. OCN used at NPAC must match OCN used in CC field on CSR and OCN for Q account in BAN field.
4. CLEC must obtain end-user authorization to request LNP before submitting LNP LSR.

5.2 LSR Order Forms for LNP

1. CLEC should complete all required fields. Refer to Section 4.2, Minimum Required Fields, in this Guide.
 2. CLEC should provide previously unassigned PON on LSR.
 3. If CLEC is porting on any day other than the Due Date stated on the FOC, the CLEC should send BellSouth a SUP LSR prior to the Due Date stated on the LSR. BellSouth will then send a revised FOC with the new due date to the CLEC.
 4. Per the BellSouth Ordering Guide for CLECs, a REF NUM may not be duplicated on an individual PON. **REF NUMs are associated with:**
 - porting numbers
 - disconnecting numbers
 - directory listings

Example: If a REF NUM is used on the Directory Listing Request form, it may not be repeated on the Number Portability/Loop form or the End User Disconnect form.

 - PONs containing duplicate REF NUMs are placed in clarification.
 5. The CLEC must advise BellSouth how to handle additional telephone numbers on the end user account. The additional telephone numbers may be associated with features such as:
 - Ringmaster
 - Surrogate Client MemoryCall
 - Flexible Call Forwarding Dial Around
-

If these telephone numbers are not porting, use the disconnect section on the End User Form to detail this information.

6. For all LNP orders, the LSR must provide the initiator's fax number in the FAX NO field, even for EDI or TAG LSRs.
7. CLEC should provide accurate cable & pair information for loop orders to avoid provisioning delays.
8. An LSR must contain numbers on one CSR. An LSR must be sent for each CSR..

5.3 Supplemental LSRs

1. If CLEC intends to port on any day other than the Due Date stated on the FOC, the CLEC should send BellSouth a SUP LSR prior to the due date originally stated on the FOC.
2. A supplemental change LSR (SUP) must reflect the same PON, CC, ATN, AN, EATN, EAN, ACT, and NPT as the original request.
3. SUP must also have a higher VER number and SUP field entry complete
4. EDI/TAG vs. FAX: EDI or TAG and Fax requests may not be combined for the same PON. If an LSR is submitted via:
 - EDI all SUPs for the PON must be sent through EDI.
 - TAG all SUPs for the PON must be sent through TAG.
 - Fax all SUPs for the PON must be faxed.

Example: The original LSR is sent via EDI and then placed in clarification by the LCSC. CLEC must send a SUP through EDI to change or cancel the request.

5.4 Clarifications

1. The CLEC has 10 business days to respond to the request for clarification by submitting a supplemental LSR.
2. If no response is received by BellSouth LCSC within 10 business days, the LSR will be canceled on the eleventh business day.
3. If original LSR is canceled by BellSouth, a new LSR with new PON must be submitted.
4. CLEC should not send Create SV to NPAC until an FOC has been received.
5. BellSouth will place SVs in Conflict if CLEC sends Create before FOC is received.

5.5 Standard Intervals

1. CLEC should review BellSouth Standard Interval Guide prior to submitting LSR.
2. The minimum Due Date for port-out is five business days after the FOC receipt date. The first TN ported in an NPA-NXX is no earlier than five business days after FOC receipt date.

5.6 NPAC Communication

1. CLEC must receive FOC from BellSouth prior to sending any NPAC SV messages (Create or Modify).
2. The CLEC should send the Create SV immediately upon receipt of FOC.
3. The Due Date on the Create SV sent to NPAC by the CLEC must match Due Date on FOC sent by BellSouth
4. The Due Time on the Create SV must be set to 00:00.
5. CLEC should send Activate SV to NPAC on FOC due date.
6. BellSouth LCSC does not issue the Disconnect service order until notification of CLEC Activate SV is received from NPAC for all TNs on the LSR. This is done to avoid disruption to end-user service.
7. For any change in the Due Date to port numbers, to cancel port, or to add/remove telephone numbers, a SUP LSR must be sent to BellSouth LCSC and CLEC must receive revised FOC prior to sending a Modify message to NPAC.

5.7 E911 Lock Down

1. CLEC must send Activate SV to NPAC before BellSouth LCSC will issue the Disconnect.
2. BellSouth will not send the Unlock Message until Disconnect service order is complete.
3. If CLEC Migrate message reaches SCC before BellSouth's Unlock Message, the CLEC Migrate message will be shown on an error report which is sent to CLECs daily. CLEC must be sure they have sent Activate SVs to NPAC for all TNs which appear on error reports from SCC. (Refer to Section 7.2 of this guide for more details)
4. CLEC and BellSouth should send Migrate and Unlock messages to SCC with the same due date as the Activate SV to NPAC.

6. System Interfaces

6.1 Interface Options for Order Submission

Ordering Options for LSRs

The CLEC must send the Local Service Request (LSRs) for Local Number Portability or Loop Service with Number Portability to the BellSouth LCSC for processing. The request may be faxed or sent electronically through Electronic Data Interchange (EDI) or Telecommunication Access Gateway (TAG).

If the LSR is received electronically, the FOC is sent to the CLEC automatically through EDI or TAG. The CLEC also receives completion notices through EDI or TAG once the service orders are complete. EDI, TAG and Fax requests may not be combined on the same PON. If an LSR is originally submitted via EDI, then all SUPS for this PON must be sent through EDI.

For further information on EDI, refer to **BellSouth Ordering Guide for CLECs**, Section 6.2.1 on Electronic Data Interchange. (EDI)

6.2 System Interface Descriptions

Local Exchange Navigational System (LENS)

Step	Action
Description	Front-end GUI application which provides pre-ordering support for LNP orders using the Inquiry function.
Inputs	Customer address, customer information
Outputs	RSAG Address Validation Service availability for a particular NPA NXX Customer record information
Notes	LNP LSRs <u>can</u> not be submitted via LENS.

PON Order Status via the Web

Step	Action
Description	Supports on-line viewing of faxed LSR order status.
Inputs	Faxed LSRs
Outputs	CLEC-specific LSR status by PON
Notes	For faxed LSRs

Fax

Step	Action
Description	Supports the transmission of manual CLEC orders.
Inputs	Paper LSR
Outputs	Clarifications; FOCs
Notes	Clarifications and FOCs for faxed LSRs are sent via fax. SUP LSRs for faxed LSRs must be submitted via fax. EDI, TAG and faxed requests may not be combined on the same PON.

Electronic Data Interchange (EDI)

Step	Action
Description	Supports the CLEC transmission of orders to BellSouth, and the acknowledgment of receipt of orders to CLEC by BellSouth.
Inputs	Digital LSR
Outputs	Clarifications; Rejects, FOCs, Pending Order Statuses, Completion Notices

Telecommunications Access Gateway (TAG)

Step	Action
Description	Supports the CLEC transmission of orders to BellSouth, and the acknowledgment of receipt of orders to CLEC by BellSouth. CLEC has access to ordering and pre-ordering functionality via TAG.
Inputs	Digital LSR
Outputs	Clarifications; Rejects, FOCs, Pending Order Statuses, Completion Notices

BellSouth LNP Gateway

Step	Action
Description	Supports both internal and external communications with various interfaces and processes, including NPAC (SOA & SMS), EDI, and TAG.
Inputs	· LNP LSRs, NPAC messages, EDI and TAG orders
Outputs	Rejects; Clarifications; FOCs NPAC concurrence messages Service orders to provisioning

NPAC

Step	Action
Description	NPAC is the third party organization that oversees the porting of telephone numbers for Local Number Portability.
Inputs	CLEC and BellSouth subscription versions.
Outputs	CLEC and BellSouth subscription versions.

Note: Interface descriptions are specific to LNP orders only.

7. Frequently Asked Questions

7.1 General

1. 1. What should be done if it is determined that some numbers sent on an LSR are not to be ported?

A sup should be sent immediately to delete the telephone numbers from the NP or LSNP form if they are not porting. The account will not be disconnected until all telephone numbers on the NP or LSNP form have been ported.

2. 2. How is a CLEC LSR validated?

The validation process includes the following steps to ensure that the requested number(s) may be ported out.

Step	Action
1	Are the porting number(s) on the LSR working number(s) on the CSR (or customer is paying to reserve the numbers)? If yes, go to step 2. If no, go to step 7.
2	Does the end user name on the LSR match the listed name and/or billing name on the CSR? If yes, go to step 3. If no, go to step 7.
3	Are the telephone number(s) on the LSR associated with a line type that is portable? Refer to Local Number Portability Rules (Section 4.2 of this guide). If yes, go to step 4. If no, go to step 7.
4	Does the service address information on the LSR match the LA or SA on the CSR? If yes, go to step 6. If no, go to step 5. Note: If the line type on the existing end user service is FX/FCO, go to step 5.
5	Is the Toll Message Rate Center (TMRC) for the porting number(s) shown on the LSR the same as the TMRC for the address shown on the LSR? If yes, go to step 6. If no, go to step 7.
6	Is LNP available for the NPA NXX at this time? If yes, go to step 8. If no, go to step 7.
7	Send CLEC Clarification request and wait for receipt of SUP LSR.
8	Proceed with Service Order Issuance Process.

3. What CLEC actions would cause an LNP request to fall out of the order process at BellSouth?

Some reasons for an LSR to fall out of the order process are:

- CLEC sent a create SV before receiving an FOC. BellSouth will put SV in Conflict with NPAC

- CLEC sent a create on the wrong TN
- CLEC sent create with due date different than FOC due date
- CLEC sent create with time other than 00:00
- CLEC ported number before or after Due Date on the FOC

If the CLEC LSR has fallen out of the order process, BellSouth will not be able to automatically send Concur SV to the CLEC Create SV.

- 4. What CLEC actions should be taken if the end user is continuing to receive a bill from BST after the account is ported out?
- CLEC should verify that the activate SV has been sent on all telephone numbers provided on the LSR. If yes, refer the account to the LCSC for investigation. If no, send the activate SV to the NPAC.

7.2 Ordering Options

1. In what form should a CLEC expect to receive an FOC, Clarification, or Reject response?
 - If an order was sent via EDI, the response will be sent via EDI.
 - If an order was sent via TAG, the response will be sent via TAG
 - If an order was sent via fax, the response will be sent via fax.
2. Why can't the status of an LSR submitted via EDI be viewed in the PON Status Reports which are available on-line?

The PON Status Reports are for orders which were submitted via fax. Status for orders submitted via EDI/TAG are received via EDI/TAG.

7.3 LSR Error Notices

1. What types of errors would require clarification?

Some examples of errors for which BellSouth will request clarification:

- Some numbers on an account are being ported, but information/instruction has not been provided on **ALL** numbers listed on the account (i.e., Ringmaster; Surrogate Client MemoryCall; Flexible Call Forwarding Dial Around (FCPAN))
- REF NUM are duplicated on the LSR
- LSR does not contain the minimum required fields
- Duplicate PON
- Data was entered into a prohibited field
- Busy cable & pair
- Incorrect address
- End user & central office are not in same wire center (may be wrong ACTL)
- Invalid ACT
- Invalid Q-account

- TN listed is not a working BellSouth TN
 - Listing 2 numbers to port from two different CSRs on one LSR
2. Why would the CLEC receive error reports from SCC, Manager of the E911 database?
If the CLEC sends the Migrate message to the SCC to lock E911 prior to SCC receiving BellSouth's Unlock message, the CLEC Migrate message will be placed on an error report (755) which is distributed daily to CLECs from SCC. SCC will mechanically process the Migrate/Unlock record match for 7 days for all 755 error messages. After 7 days the record will move to a 760 error file. SCC will manually continue to look for the record match there. CLEC should be sure that the Activate SV has been sent to NPAC for the Migrate messages which appear on the 755 or 760 error reports.

7.4 Due Dates

1. What are the key steps to changing the Due Date for a previously submitted LNP LSR?
The most important part of a Due Date change is submitting a SUP LSR to the BellSouth LCSC and receipt of a revised FOC prior to sending the Modify SV to NPAC. If the Modify SV is sent to NPAC prior to receipt of the revised FOC from BellSouth, the LSR will fall out of the order process at BellSouth. Due Date changes should be requested prior to the due date and not later than the due date originally stated.
2. Why does the FOC have a Due Date which is different than the Desired Due Date?
If the Desired Due Date on the original LSR did not adhere to BellSouth Standard Intervals for LNP orders, then the Due Date on the FOC would reflect the appropriate interval. Refer to BellSouth Standard Interval Guide for more details.
3. Why does the CLEC have to send the Activate SV on the Due Date?
If the CLEC sends the Activate SV before or after the Due Date on the FOC, end user service could be impacted.

7.5 NPAC Communication

1. What does it mean when a CLEC receives an SV with Authorization set to NO (Conflict) from NPAC?
This SV indicates that the CLEC sent a Create SV to NPAC prior to receipt of an FOC for the TN. CLEC should check for receipt of an FOC for the TN.
2. Why can't the CLEC send the Create SV to NPAC prior to receiving an FOC from BellSouth?
If the CLEC sends the Create SV to NPAC prior to receiving an FOC from BellSouth, BellSouth will send SV with Authorization set to NO (Conflict) to NPAC. CLEC should follow industry flow for successful porting.
3. How does CLEC know BellSouth is ready to port number?
CLEC should complete the following steps at least the day before the due date:
- verify FOC was received
 - verify FOC due date
 - verify SV is Pending with Concurrence for all TNs on LSR

- verify SV due date is same as FOC due date for all TNs on LSR
4. What happens if the NPAC telephone number disconnect option is used after sending the activate (number ported) message?
- The telephone number and not the end user is returned to BellSouth. The CLEC must arrange to provide service for the end user because upon receipt of the Activate SV, BST will proceed with the disconnect order.

8. LNP Ordering Checklist

8.1 LNP Ordering Checklist

1. Pre- Submission: The LSR Form for LNP

Has the pre-order information been validated? CLECs may access pre-order support using a web browser and the LENS interface. Use the Inquiry function to confirm the accuracy of the following information:

- TNs on LSR match TNs on CSR
 - LSR address is RSAG valid
2. Have you included/checked the following items:
 - Previously unassigned PON on LSR
 - Unique REF NUMs on all associated forms for LSR
 - Minimum required fields are complete
 3. Is there a Q-account for each OCN registered at the NPAC and stated on the LSR in the CC field?
 4. Were BellSouth Standard Due Date Intervals followed when assigning the Desired Due Date? (Refer to BellSouth Products and Services Interval Guide.)

5. NPAC Communication

Do not send NPAC messages (e.g., Create or Modify) prior to receipt of FOC. (For original LSR or SUP LSR)

6. The Create SV should be sent immediately upon receipt of FOC by the CLEC for all TNs on the LSR.
7. Does the Due Date on Create message must match Due Date on FOC sent by BST?
8. For any change in the Due Date to port numbers, a SUP LSR must be sent to BellSouth LCSC prior to sending a Modify message to NPAC. Any other changes, such as Cancellations, also require a SUP LSR.
9. Does the Due Time have setting of 00:00?

10. E911 Lockdown

The Migrate message to lock records at an E911 SCC should be sent after the Activate message is sent to NPAC.

Note: This list is not all inclusive, but highlights the actions which would most contribute to the submission of a valid LSR.

9. Glossary of LNP Terms

9.1 Glossary of LNP Terms

Advanced Intelligent Network (AIN)	Evolving, service-independent network architecture that provides important new capabilities for rapid creation of customized telecommunications services. AIN offers one way for a network element to query a central database to obtain local number portability routing information.
BST	Acronym used to indicate BellSouth.
Central Office (CO)	An environmentally controlled space in which a telecommunications network switching system and other associated operating systems are installed.
Central Office Exchange (CENTREX)	A telephone service offered by LSPs that provides the end-user with advanced features and services from the LSPs EO
Clarification	Requested by BellSouth LCSC when an CLEC LSR contains incomplete or inaccurate information which requires further documentation from the CLEC to allow order processing to continue.
Competitive Local Exchange Carrier (CLEC)	A new entrant into a market where there is already an incumbent LEC (ILEC) providing local phone service.
Conflict	An SV status which indicates that an error has occurred in the ordering process which will require further CLEC action for BellSouth to resume order processing. For example, BST will place SV in conflict if CLEC sends a Create SV before an FOC has been issued.
Directory Number (DN)	An end-user's telephone number, also known as a TN. In its most restrictive definition, an end-user number which is listed in a directory or with directory assistance.
Donor Switch	Switch/Office/Exchange Refers to the local switch from which an end-user was served, prior to changing SPs.

End Office (EO)	A switching system used to provide local service for a local telephone company; also known as a central office. End offices are typically equipped with both line and trunk terminations.
Fall-Out	Human eyes are needed to review the order, e.g. with a partial migration.
Fatal Reject	A type of error which suggests that the minimal requirements of an LSR were not fulfilled. For example, a missing required field or a duplicate PON. A Fatal Reject will not allow the CLEC order to be processed further by the BellSouth LCSC.
Federal Communications Commission (FCC)	Congressionally credited governmental agency with the responsibility to direct the U.S. national and international telecommunications regulatory environment.
Firm Order Confirmation (FOC)	Verification/acknowledgment from one SP to another of receipt of a valid Local Service Request (LSR)
Incumbent Local Exchange Carrier (ILEC)	Typically, the RBOC or independent who services local end-users (prior to a market opening up to local competition)
Intelligent Network (IN)	Hardware and software platform used to provide enhanced voice, video and data services. IN offers one way for a network element to query a central database to obtain local number portability routing information.
Inter-Exchange Carrier (IXC)	A carrier that provides connections between LATAs, between serving areas, and between LATAs and serving areas where the calling or called end-user is located in the United States.
Interim Number Portability (INP)	A temporary solution for porting telephone numbers that routes calls to the CLEC wire center using: <ul style="list-style-type: none">• Remote Call Forwarding (RCF)• Direct Inward Dialing (DID)• Route Index Hubbing (RTI)
Local Exchange Carrier (LEC)	A company that provides local telephone service. LECs also include independent local telephone companies.

Local Exchange Routing Guide (LERG)	Bellcore administered Network Routing and V&H Coordinate information for U.S. Telecommunications Industry and others.
Local Number Portability (LNP)	Provides end users with the ability to retain their numbers when they change their local service provider.
Local Number Portability Gateway (LNP GW)	A BellSouth System created to support LNP that: <ul style="list-style-type: none">• includes desktop application for LCSC Service Representatives.• is used to process LNP LSR's on-line.• communicates with the NPAC.• interfaces with the AIN database to update call routing information.
Local Service Management System (LSMS)	The LSP owned network database which holds downloaded ported number information.
Local Service Provider (LSP)	A company that provides basic local telephone service.
Location Routing Number (LRN)	A routing code that is: <ul style="list-style-type: none">• unique• 10 digits• identifies the switch in which a ported number resides. LRN utilizes AIN triggers, SS7 signaling, and unique 10-digit code for switch identification.
Lockheed-Martin IMS (LM-IMS)	The neutral third-party administrator for the LNP database NPAC.
New Service Provider (NSP)	Subscribers selection of exchange carrier that will be providing dial tone. This will usually be the exchange carrier that is not the default SP for the NPA NXX. This would be the recipient switch for the porting of a number when the end-user is being ported. When the end-user is changing from ported to non-porting the NSP would be the donor switch.
Non-Portable Number	Numbers are those that have not been designated as ported exchanges or portable capabilities in the LERG.
North American Numbering Council (NANC)	FCC -mandated task force assigned to oversee NPAC and NANP administration for the U.S. telecommunications industry.

North American Numbering Plan (NANP)	A plan for the allocation of unique 10 digit address numbers. The numbers consist of a 3 digit area (numbering plan area) code, a 3 digit office code, and a 4 digit line number. The plan also extends to format variations (e.g., 3 digit and 7 digit address), prefixes (e.g., 1, 0, 01 and 011), and special code applications (e.g., Service Access Codes).
Number Portability Administration Center (NPAC)	A neutral third party vendor contracted by BellSouth and the CLEC's to: <ul style="list-style-type: none">• maintain the master database for LNP.• coordinate the flow of information between service providers.
Numbering Plan Area (NPA)	A defined geographic area identified by a unique three digit code used in the North American Numbering Plan Area.
NXX	End Office Code A three digit code used to identify a central office exchange. However, in a portable environment the last 4 digits or the 7-digit telephone number may not always reside in the central office exchange to which the NXX was natively assigned.
Plain Old Telephone Service (POTS)	Basic residence or business telephone service which provides users with simple telephone features or service.
Port In	A term used with Local Number Portability to indicate that a customer is changing his facility based local service provider from a CLEC to BellSouth and wishes to keep his same telephone number.
Port Out	A term used with Local Number Portability to indicate that a BellSouth customer is taking his telephone number with him to another facility based local service provider.
Portability	The ability of the user to change local telephone companies, location and/or service without changing the telephone number.

Portable Number	<p>Those numbers within an exchange that have portable capabilities and are assigned to a designated portable exchange. These are the numbers that are assigned to the designated default switch and have not been ported to another LSP. These numbers are commonly identified as working on the "Donor" switch.</p> <p>Portable numbers are all numbers in an NXX where portability is allowed. Numbers will be declared portable on an NXX basis.</p>
Ported Number	<p>Those that have been assigned to other LSPs providing recipient switch access for Portable exchanges. This is commonly termed as the numbers assigned to the "Recipient" switches. The "Recipient" switch is not the default switch in the SCP. Ported numbers are the subset of portable numbers that have actually been moved from the LERG based switch (donor) to another switch (recipient).</p>
Private Branch Exchange (PBX)	<p>System typically installed in a business that serves as the central telephone system for that business and which may provide certain enhanced services for that business.</p>
Recipient Switch	<p>Switch/Office/Exchange — Refers to local end office switch to which an end-user is served, after changing SPs.</p>
Remote Call Forwarding (RCF)	<p>LNP deployment model generally viewed as an interim solution. For customers changing their local telephone company and wanting to keep their phone number, routes all incoming calls to the old company switch first. Then the calls are forwarded to a new phone</p>
SCC	<p>Neutral third party responsible for the E911 database administration. (SCC is not an abbreviation.)</p>
Service Management System (SMS)	<p>Computer facility permitting access to records contained in the number portability database. Receives Number Ported messages from NPAC.</p>
Service Order Administration (SOA)	<p>Interface to the NPAC for porting end-user TNs. Receives create and sends concurrence SVs.</p>
Service Provider (SP)	<p>A company that provides telephone service.</p>
Subscription Version (SV)	<p>A message that flows through the NPAC to provide information regarding LNP.</p>

Telecommunications Access Gateway
(TAG)

TAG is a transaction based messaging system with data translation. TAG provides a by-directional flow of information between the CLEC and BellSouth, and gives the CLEC access to pre-ordering and ordering functionality.

Toll Message Rate Center (TMRC)

A uniquely defined geographic area:

- created to allow for the proper rating of toll and message charges.
- appears in LERG for a wire center/switch.

Trigger Order

6-Digit Trigger – identifies NPA XXX that is portable and causes querying. 10-Digit Trigger – end-users' telephone number. This trigger causes look up process so when the 10-digit trigger is dialed the call is routed through AIN to the SS7 database.

Note: "Trigger" is not available for all service types.

BELLSOUTH / ATT RATES
SERVICE PROVIDER NUMBER PORTABILITY
Kentucky

CATEGORY	NOTES	RATES ELEMENT	Interim Indicator	Zone	BCS	USOC	RATES				OSS RATES								
							Nonrecurring		Nonrecurring		Svc Order Submitted Elec per LSR	Svc Order Submitted Manually per LSR	Incremental Charge - Manual Svc Order vs. Electronic-1st	Incremental Charge - Manual Svc Order vs. Electronic-Add'l	Incremental Charge - Manual Svc Order vs. Electronic-Disc 1st	Incremental Charge - Manual Svc Order vs. Electronic-Disc Add'l			
							Rec	First	Add'l	First							Add'l	SOMECS	SOMAN
	<p>Note: If no rate is identified in the contract, the rate for the specific service or function will be as set forth in applicable BellSouth tariff or as negotiated by the Parties upon request by either Party.</p>																		
	<p>1) Until the FCC issues its order implementing a cost recovery mechanism for permanent number portability, the Company will track its costs of providing interim SPNP with sufficient detail to verify the costs. This will facilitate the Florida PSCs consideration of the recovery of these costs in Docket 950737-TP. (FL)</p>																		
	<p>2) BellSouth and CLEC will each bear their own costs of providing remote call forwarding as an interim number portability option. (KY)</p>																		

ATTACHMENT 6
CONNECTIVITY BILLING AND RECORDING

ATTACHMENT 6

CONNECTIVITY BILLING AND RECORDING

TABLE OF CONTENTS

1.1 GENERAL 3
1.2 BILLABLE INFORMATION AND CHARGES 5
1.3 MEET POINT BILLING 6
1.4 COLLOCATION 8
1.5 RIGHT-OF-WAY 9
1.6 INFORMATION SERVICES 9
1.7 LOCAL NUMBER PORTABILITY 9
1.8 ISSUANCE OF BILLS - GENERAL 9
1.9 ELECTRONIC TRANSMISSIONS 10
1.10 TAPE OR PAPER TRANSMISSIONS 12
1.11 TESTING REQUIREMENTS 18
1.12 ADDITIONAL REQUIREMENTS 19
1.13 BILL ACCURACY CERTIFICATION 19
1.14 PAYMENT OF CHARGES 20
1.15 BILLING DISPUTES 20
1.16 LATE PAYMENT CHARGES 22
1.17 DISCONTINUANCE OF SERVICE 22
1.18 ADJUSTMENTS 23
2. PROVISION OF CUSTOMER USAGE DATA 24
2.1 INTRODUCTION 24
3. LOCAL ACCOUNT MAINTENANCE 25

EXHIBIT A, LINE INFORMATION DATA BASE (“LIDB”) STORAGE
AGREEMENT 26

EXHIBIT B, RAO HOSTING 31

EXHIBIT C, OPTIONAL DAILY USAGE FILE 36

EXHIBIT D, ENHANCED OPTIONAL DAILY USAGE FILE 40

EXHIBIT E, RATES

CONNECTIVITY BILLING AND RECORDING

1.1 General

- 1.1.1 This Section describes the requirements for BellSouth to bill and record all charges AT&T incurs for purchasing: (a) telecommunications services that BellSouth currently provides, or may offer hereafter for resale; (b) interconnection of BellSouth's network to AT&T's network; (c) certain unbundled Network Elements and certain combinations of such unbundled Network Elements (Network Elements and Combinations) (resale, interconnection, Network Elements and Combinations) shall collectively be referred to as "Billed Services"); and to provide Meet Point Billing and Mutual Compensation.
- 1.1.2 After receiving certification as a local exchange company from the appropriate regulatory agency, AT&T will provide the appropriate BellSouth service center the necessary documentation in order for BellSouth to establish service for AT&T.
- 1.1.3 Prior to submitting orders to BellSouth for local service, a master account must be established for AT&T. AT&T is required to provide the following before a master account is established: proof of PSC/PUC certification, the Application for Master Account, an Operating Company Number ("OCN") assigned by the National Exchange Carriers Association ("NECA") and a tax exemption certificate, if applicable.
- 1.1.4 Payment of all charges will be the responsibility of AT&T. AT&T shall make payment to BellSouth for all services billed. BellSouth is not responsible for payments not received by AT&T from AT&T's end user. BellSouth will not become involved in billing disputes that may arise between AT&T and its end user. Payments made to BellSouth as payment on account will be credited to an accounts receivable master account and not to an end user's account.
- 1.1.5 Upon proof of tax exempt certification from AT&T, the total amount billed to AT&T will not include any taxes due from the end user to reflect the tax exempt certification and local tax laws. AT&T will be solely responsible for the computation, tracking, reporting, and payment of taxes applicable to AT&T's end user.
- 1.1.6 BellSouth will not perform billing and collection services for AT&T as a result of the execution of this Agreement. All requests for billing services should be referred to the appropriate entity or operational group within BellSouth.

- 1.1.7 In order to safeguard its interest, BellSouth reserves the right to secure the account with a suitable form of security deposit, unless satisfactory credit has already been established. A CLEC may be deemed to have satisfactory credit if it rates a 5.0 or better on the Dun & Bradstreet Risk Assessment Monitor. In addition, in determining satisfactory credit, BellSouth evaluates factors such as payment history with suppliers, bank relationships, audited financial statement ratios, years in business, management history, number of liens, suits or judgments and pay history with BellSouth. To the extent not required as of the effective date of this Agreement, AT&T shall not be required to furnish a security deposit or letter of credit to BellSouth absent an adverse material change in financial circumstances thereafter as determined in accordance with the foregoing factors. Such adverse material changes may be measured based upon changes that alone would not be deemed material but when considered in conjunction with past adverse trends, including adverse trends occurring prior to the effective date hereof, constitute an adverse material change.
- 1.1.7.1 Such security deposit shall take the form of an irrevocable Letter of Credit or other forms of security acceptable to BellSouth. Any such security deposit may be held during the continuance of the service as security for the payment of any and all accounts accruing for the service.
- 1.1.7.2 If a security deposit is required, such security deposit shall be made prior to the inauguration of service.
- 1.1.7.3. Such security deposit may not exceed two months' estimated billing.
- 1.1.7.4. The fact that a security deposit has been made in no way relieves AT&T from complying with BellSouth's regulations as to advance payments and the prompt payment of bills on presentation nor does it constitute a waiver or modification of the regular practices of BellSouth providing for the discontinuance of service for non-payment of any sums due BellSouth.
- 1.1.7.5 BellSouth reserves the right to increase the security deposit requirements when, in its reasonable judgment, material changes in AT&T's financial circumstances so warrant and/or gross monthly billing has increased significantly beyond the level initially used to determine the security deposit.
- 1.1.7.6 In the event that AT&T defaults on its account, service to AT&T will be terminated in accordance with Section 1.7 of this Attachment and any security deposits held will be applied to its account.
- 1.1.7.7 Interest on a security deposit shall accrue and be paid in accordance with the terms in the appropriate BellSouth tariff.

1.2 Billable Information and Charges

- 1.2.1 BellSouth will bill and record in accordance with this Agreement those charges AT&T incurs as a result of AT&T's purchasing Billed Services from BellSouth. BellSouth will bill charges for Billed Services through Carriers Access Billing System ("CABS") or in the CABS format. BellSouth will format all bills in CBOS Standard or CRIS/CLUB format, depending on the type of service ordered, and will include sufficient bill detail to identify the particular services ordered. For those Billed Services where standards have not yet been developed, BellSouth's billing format will change as necessary when standards are finalized by the industry forum.
- 1.2.2 BellSouth shall provide AT&T a monthly bill that includes all charges incurred by and credits and/or adjustments due to AT&T for those Billed Services ordered, established, utilized, discontinued or performed pursuant to this Agreement. Each bill provided by BellSouth to AT&T shall include: (1) all non-usage sensitive charges incurred for the period beginning with the day after the current bill date and extending to, and including, the next bill date; (2) any known unbilled non-usage sensitive charges for prior periods; (3) unbilled usage sensitive charges for the period beginning with the last bill date and extending through the current bill date, except for detail usage for resold services which could extend beyond the current bill date, which are: per use vertical services, directory services, operator charges, IntraLATA toll and optional calling plans, excluding Watsaver® Service; (4) any known unbilled usage sensitive charges for prior periods; and (5) any known unbilled adjustments. Each bill shall set forth the quantity and description of each such Billed Services billed to AT&T. All charges billed to AT&T must indicate the state from which such charges were incurred except in cross boundary state situations. A listing of cross boundary exchanges has been provided to AT&T.
- 1.2.3 The Bill Date, as defined herein, must be present on each bill transmitted by BellSouth to AT&T and must be a valid calendar date. Bills should not be rendered for any charges which are incurred under this agreement on or before one (1) year preceding the bill date. However, both parties recognize that situations exist which would necessitate billing beyond the one (1) year limit, as permitted by law. These exceptions are:
- 1.2.3.1 Charges connected with jointly provided services whereby meet point billing guidelines require either party to rely on records provided by a third party;
- 1.2.3.2 Charges incorrectly billed due to error in or omission of customer provided data such as PIU and PLU factors, or other ordering data.

- 1.2.3.3 Both parties agree that these limits will be superceded by any Bill Accuracy Certification Agreement which might be negotiated between the parties.
- 1.2.4 Charges for Billed Services shall be in conversation seconds for those services that are billed based on conversation time. For resold services, charges will be billed in accordance with retail billing standards. For other than resold services, the total seconds per chargeable rate element per end office will be totaled and rounded to the nearest whole minute. The incremental seconds per chargeable rate element per end office will be totaled and rounded to the next whole minute. Self reporting factors such as PLU and PIU will be used to determine jurisdiction of unidentifiable traffic.
- 1.2.5 Billing Account Numbers (“BANS”) will be established in accordance with BellSouth billing policy and OBF standards. The BellSouth billing policy in effect at the time this Agreement is signed will govern the billing account structure during the term of this Agreement. BellSouth will provide such policy to AT&T at such time. Changes to the BellSouth billing policy will be co-ordinated with AT&T and the AT&T Account Team to ensure that AT&T will not be adversely impacted by such changes. AT&T may request that certain categories of charges be included in separate bills which are to be sent to different billing addresses. AT&T will submit such request through the Bona Fide Request/New Business Request (“BFR/NBR”) process set forth in Attachment 10 of this Agreement, incorporated herein by this reference.
- 1.2.6 Each Party shall provide the other Party, at no additional charge, a contact person for the handling of any billing questions or problems that may arise during the implementation and performance of the terms and conditions of this Attachment 6. Billing questions subsequent to implementation will be directed to the appropriate BellSouth billing specialist.

1.3 Meet Point Billing

- 1.3.1 Where appropriate, AT&T and BellSouth will establish meet-point billing (“MPB”) arrangements in accordance with the Meet-Point Billing guidelines adopted by and contained in the OBF’s MECAB and MECOD documents, except as modified herein. Both Parties will individually and collectively maintain provisions in their respective federal and state access tariffs, and/or provisions within the National Exchange Carrier Association (“NECA”) Tariff No. 4, or any successor tariff to reflect the MPB arrangements identified in this Agreement, in MECAB and in MECOD.

- 1.3.2 AT&T and BellSouth will implement the "Multiple Bill/Multiple Tariff" option in order to bill any interexchange carrier ("IXC") for that portion of the jointly provided switched exchange access service provided by AT&T or BellSouth.
- 1.3.3 BellSouth shall provide to AT&T the billing name, billing address, and carrier identification code ("CIC") of the IXCs that may utilize any portion of AT&T's network in an AT&T/BellSouth MPB arrangement in order to comply with the MPB Notification process as outlined in the MECAB document. Such information shall be provided to AT&T in the format and via the medium that the Parties agree. If BellSouth does not have a CIC for any IXC that will utilize a portion of AT&T's network in an AT&T/BellSouth MPB arrangement, and for whom BellSouth must supply to AT&T MPB billing information, BellSouth agrees that it will assist such carrier in obtaining a CIC expeditiously. Until such carrier has obtained a CIC, BellSouth will submit BellSouth's CIC on those MPB records provided to AT&T for MPB. BellSouth understands and agrees that it will be solely responsible for obtaining any reimbursements from those carriers who have utilized the jointly provided networks of BellSouth and AT&T.
- 1.3.4 BellSouth and AT&T agree that in an MPB arrangement where one Party provides local transport and the other Party provides the end office switching, the Party who provides the end office switching is entitled to bill any residual interconnection charges ("RIC") and common carrier line ("CCL") charges associated with the traffic. The Parties further agree that in those MPB situations where one Party sub-tends the other Party's access tandem, the Party providing the access tandem is only entitled to bill the access tandem fee and any associated local transport charges. The Parties also agree that the Party who provides the end office switching is entitled to bill end office switching fees, local transport charges, RIC and CCL charges, as appropriate, and such other applicable charges. BellSouth and AT&T agree that in a MPB arrangement, where transport is jointly provided, and/or the tandem is owned by one Party and the end office is owned by the other Party, charges will be billed using tariff rates and in accordance to MECAB guidelines.
- 1.3.5 BellSouth and AT&T will record and transmit switched exchange access service records in accordance with the MECAB standards. Such data shall be transmitted to the other Party within ten (10) days of its recording. BellSouth and AT&T will coordinate and exchange the billing account reference ("BAR") and billing account cross reference ("BACR") numbers or Operating Company Number ("OCN"), as appropriate, for the MPB arrangements described in this Agreement. Each Party will notify the other if the level of billing or other BAR/BACR elements change, resulting in a new BAR/BACR number.

- 1.3.6 If MPB data is not processed and delivered by either BellSouth or AT&T and sent to the other Party within ten (10) days of their recording and in turn such Party is unable to bill the IXC for the appropriate charges, the Party who failed to deliver the data will be held liable for the amount of the unbillable charges.
- 1.3.7 If MPB data is not submitted within ten (10) days of their recording or is not in the proper format as set forth in this Agreement, and if as a result the other Party is delayed in billing the IXC for the appropriate charges it incurs, the delaying Party shall pay the other Party a late MPB data delivery charge which will be the total amount of the delayed charges times the highest interest rate (in decimal value) which may be levied by law for commercial transactions, compounded daily for the number of days from the date the MPB charges should have been received to and including the date the MPB charge information is actually received.
- 1.3.8 Errors in MPB data exchanged by the Parties may be discovered by AT&T, BellSouth or the billable IXC. Both AT&T and BellSouth agree to provide the other Party with notification of any discovered errors within two (2) business days of the discovery. The other Party shall correct the error within eight (8) business days of notification and resubmit the data. In the event the errors cannot be corrected within the time period specified above, the erroneous data shall be considered lost. If MPB data is lost due to incorrecable errors or otherwise, the Parties shall follow the procedures set forth in Section 1.15 of this Attachment 6.
- 1.3.9 Both Parties will provide the other a single point of contact to handle any MPB questions.
- 1.3.10 MPB will apply for all traffic bearing the 500, 700, 900, 8YY or any other non-geographic NPA which may be likewise designated for such traffic in the future.

1.4 Collocation

- 1.4.1 When AT&T collocates with BellSouth in BellSouth's facility as described in this Agreement, capital expenditures (e.g., costs associated with building the "cage"), shall not be included in the bill provided to AT&T pursuant to this Attachment 6. All such capital expenses shall be given a unique BAN and invoice number. All invoices for capital expenses shall be sent to the location specified by AT&T for payment. All other non-capital recurring collocation expenses shall be billed to AT&T in accordance with this Agreement. The CABS Billing Output Specifications ("BOS") documents provide the guidelines on how to bill the charges associated with collocation.

The bill label for those collocation charges shall be entitled "Expanded Interconnection Service." For those nonmechanized bills, the bill label for non-capital recurring collocation expenses shall be entitled "Collocation".

1.5 Right-of-Way

1.5.1 Billing for right-of-way, poles and conduits will be addressed in Attachment 8 of this Agreement, incorporated herein by this reference.

1.6 Information Services

1.6.1 The transport for 976 and other information services calls will be billed in accordance with the reciprocal compensation arrangement described in Attachment 3 of this Agreement, incorporated herein by this reference.

1.7 Local Number Portability

1.7.1 When an IXC terminates an interLATA or intraLATA toll call to an AT&T local exchange customer whose telephone number has been ported from BellSouth, the Parties agree that AT&T shall receive those IXC access charges associated with end office switching, local transport, RIC and CCL, as appropriate. BellSouth shall receive any access tandem fees, dedicated and common transport charges, to the extent provided by BellSouth, and any Service Provider Number Portability ("SPNP") fees (i.e., such as RCF charges) set forth in this Agreement. When a call for which access charges are not applicable is terminated to an AT&T local exchange customer whose telephone number has been ported from BellSouth, and is terminated on AT&T's own switch, the Parties agree that the mutual compensation arrangements described in this Agreement shall apply.

1.8 Issuance of Bills - General

1.8.1 BellSouth and AT&T will issue all bills in accordance with the terms and conditions set forth in this Section. BellSouth and AT&T will establish monthly billing dates ("Bill Date") for each Billing Account Number ("BAN"). Each BAN shall remain constant from month to month, unless changed as agreed to by the Parties. Each Party shall provide the other Party at least thirty (30) calendar days written notice prior to changing, adding or deleting a BAN. The Parties will provide one billing invoice associated with each BAN. Each invoice must contain an invoice number (which will vary from month to month). The bill date is the only varying invoice number available on the Resale bill. On each bill associated with a BAN, the appropriate invoice number and the charges contained on such invoice must be reflected. All bills must be received by the other Party no later than ten (10) calendar

days from Bill Date and at least twenty (20) calendar days prior to the payment due date, whichever is earlier. Any bill received on a Saturday, Sunday or a day designated as a holiday by the Chase Manhattan Bank of New York (or such other bank as AT&T shall specify) will be deemed received the next business day. If either Party fails to receive billing data and information within the time period specified above, the payment due date will be extended by the number of days the bill is late.

- 1.8.2 BellSouth and AT&T shall issue all CABS bills or bills in CBOS format containing such billing data and information in accordance with the most current version of CBOS, or if development time is required, within two (2) versions of the current CBOS standard. To the extent that there are no CBOS or MECAB standards governing the formatting of certain data, such data shall be issued in the format as mutually agreed upon by the parties.
- 1.8.3 Within thirty (30) days of finalizing the chosen billing media, each Party will provide the other Party written notice of which bills are to be deemed the official bills to assist the Parties in resolving any conflicts that may arise between the official bills and other bills received via a different media which purportedly contain the same charges as are on the official bill. If either Party requests an additional copy(ies) of a bill, such Party shall pay the other Party a reasonable fee per additional bill copy, unless such copy was requested due to errors, omissions, or corrections or the failure of the transmission to comply with the specifications set forth in this Agreement.
- 1.8.4 When sending bills via electronic transmission, to avoid transmission failures or the receipt of billing information that cannot be processed, the Parties shall provide each other with their respective process specifications. Each Party shall comply with the mutually acceptable billing processing specifications of the other. AT&T and BellSouth shall provide each other reasonable notice if a billing transmission is received that does not meet such Party's specifications or that such Party cannot process. Such transmission shall be corrected and resubmitted to the other Party, at the resubmitting Party's sole expense, in a form that can be processed. The payment due date for such resubmitted transmissions will be twenty (20) days from the date that the transmission is received in a form that can be processed and that meets the specifications set forth in this Attachment 6.

1.9 Electronic Transmissions

- 1.9.1 BellSouth and AT&T agree that each Party will transmit billing information and data in the appropriate CABS format electronically via CONNECT:Direct to the other Party at the location specified by such

Party. The Parties agree that a T1.5 or 56kb circuit to Gateway for CONNECT:Direct is required. AT&T data centers will be responsible for originating the calls for data transmission via switched 56kb or T1.5 lines. If BellSouth has an established CONNECT:Direct link with AT&T, that link can be used for data transmission if the location and applications are the same for the existing link. Otherwise, a new link for data transmission must be established. BellSouth must provide AT&T/Alpharetta its CONNECT:Direct Node ID and corresponding VTAM APPL ID before the first transmission of data via CONNECT:Direct. AT&T's CONNECT:Direct Node ID is "NDMATTA4" and VTAM APPL ID is "NDMATTA4" and must be included in BellSouth's CONNECT:Direct software. AT&T will supply to BellSouth its RACF ID and password before the first transmission of data via CONNECT:Direct. Any changes to either Party's CONNECT:Direct Node ID must be sent to the other Party no later than twenty-one (21) calendar days before the changes take effect.

- 1.9.2 The following dataset format shall be used as applicable for those charges transmitted via CONNECT:Direct in CABS format:

Production Dataset

AF25.AXXXXYYY.AZZZ.DDDEE	Production Dataset Name
AF25 =	Job Naming Convention
AXXXX =	Numeric Company Code
YYY =	LEC Remote
AZZZ =	RAO (Revenue Accounting Office)
DDD =	BDT (Billing Data Tape with or without CSR), MEGA, JBILL, TCGXX (XX=Bill Period), or CSR (Customer Service Record)
EE =	01 thru 31 (Bill Period) (optional) or GA (US Postal-State Code)

Test Dataset

AF25.ATEST.AXXXX.DDD	Test Dataset Name
AF25.ATEST =	Job Naming Convention
AXXXX =	Numeric Company Code
DDD =	BDT (Billing Data Tape with or without CSR) or CSR (Customer Service Record)

1.10 Tape or Paper Transmissions

- 1.10.1 In the event either Party does not temporarily have the ability to send or receive data via CONNECT:Direct, that Party will transmit billing information to the other party via magnetic tape or paper, as agreed to by AT&T and BellSouth. Billing information and data contained on magnetic tapes or paper for payment shall be sent to the Parties at the following locations. The Parties acknowledge that all tapes transmitted to the other Party via U.S. Mail or Overnight Delivery and which contain billing data will not be returned to the sending Party.

TO AT&T:

Tape Transmissions via U.S. Mail:	AT&T Attention: Bill Access Coordinator 300 North Point Parkway FLOC 144C09 Alpharetta, Georgia 30005
Tape Transmissions via Overnight Delivery:	AT&T Attention: Bill Access Coordinator 500 North Point Parkway FLOC 144C09 Alpharetta, Georgia 30005

Paper Transmissions via U.S. Mail:	AT&T Attention: Bill Access Coordinator Caller Service 6908 Alpharetta, Georgia 30009
Paper Transmissions via Overnight Delivery:	AT&T Attention: Bill Access Coordinator 500 North Point Parkway FLOC B1404 Alpharetta, Georgia 30005

TO BellSouth:

Tape Transmissions:	BellSouth 600 N. 19th Street 7th Floor Birmingham, Alabama 35203 Attn: Interconnection Purchasing Center
Paper Transmissions:	BellSouth 600 N. 19th Street 7th Floor Birmingham, Alabama 35203 Attn: Interconnection Purchasing Center

- 1.10.2 Each Party will adhere to the tape packaging requirements set forth in this subsection. Where magnetic tape shipping containers are transported in freight compartments, adequate magnetic field protection shall be provided by keeping a typical 6-inch distance from any magnetic field generating device (except a magnetron-tape device). The Parties agree that they will only use those shipping containers that contain internal insulation to prevent damage. Each Party will clearly mark on the outside of each shipping container its name, contact and return address. Each Party further agrees that it will not ship any billing tapes in tape canisters.
- 1.10.3 All billing data transmitted via tape must be provided on a cartridge (cassette) tape and must be of high quality, conform to the Parties' record and label standards, 9-track, odd parity, 6250 BPI, group coded recording mode and extended binary-coded decimal interchange code ("EBCDIC"). Each reel of tape must be 100% tested at 20% or better "clipping" level with full width certification and permanent error free at final inspection. AT&T reserves the right to destroy a tape that has been determined to have unrecoverable errors. AT&T also reserves the right to replace a tape with one of equal or better quality.
- 1.10.4 Billing data tapes shall follow CBOS standards.
- 1.10.5 A single 6-digit serial number must appear on the external (flat) surface of the tape for visual identification. This number shall also appear in the "dataset serial number field" of the first header record of the IBM standard tape label. This serial number shall consist of the character "V" followed by the reporting location's four digit Originating Company Code and a numeric character chosen by the sending company. The external and internal label shall be the same. The dataset name shall appear on the flat side of the reel and also in the "data set name field" on the first header record of the IBM standard tape label. BellSouth's name, address, and contact shall appear on the flat side of the cartridge or reel.
- 1.10.6 Tape labels shall conform to IBM OS/VS Operating System Standards contained in the IBM Standard Labels Manual (GC26-3795-3). IBM standard labels are 80-character records recorded in EBCDIC, odd parity. The first four characters identify the labels:

Volume 1	Volume label
HDR1 and HDR2	Data set header labels
EOV1 and EOV2	Data set trailer labels (end-of-volume for multi-reel files)
EOF1 and EOF2	Data set trailer labels (end-of-data-set)

The HDR1, EOVI, and EOF1 labels use the same format and the HDR2, EOVI, and EOF2 labels use the same format.

1.10.7 The Standard Volume Label Format (Vol. 1) is described below:

FIELD NAME	CONTENTS
Label Identifier (3 bytes)	The characters "VOL" identify this label as a volume label.
Label Number (1 byte)	The relative position of this label within a set of labels of the same type; it is always a 1 for the IBM standard volume label.
Volume Serial Number (6 bytes)	A unique identification code, normally numeric characters (000001-999999), but may be alpha-numeric; if fewer than 6 characters, must be left-justified. This same code should also appear on the external (flat) surface of the volume for visual identification.
Reserved (1 byte)	Reserved for future use - should be recorded as blanks.
VTOC Pointer (10 bytes)	Direct-access volumes only. This field is not used for tape volumes and should be recorded as blanks.
Reserved (10 bytes)	Reserved for future use - should be recorded as blanks.
Owner Name and Address Code(10 bytes)	Indicates a specific customer, person, installation, department, etc., to which the volume belongs. Any code or name is acceptable.
Reserved (29 bytes)	Reserved for future use - should be recorded as blanks.

1.10.8 The IBM Standard Dataset Label 1 Format (HDR1, EOVI, EOF1) is described below:

FIELD NAME	CONTENTS
Label Identifier (3 bytes)	Three characters that identify the label are: HDR Header label (at the beginning of a dataset) EOV Trailer label (at the end of a tape volume, when the dataset continues on another volume) EOF Trailer label (at the end of a dataset).
Label Number (1 byte)	The relative position of this label within a set of labels of the same type; it is always a 1 for dataset label 1.
Dataset Identifier (17 bytes)	The rightmost 17 bytes of the dataset name (includes GnnnVnn if the dataset is part of a generation data group). If the dataset name is less than 17 bytes, it is left-justified and the remainder of this field is padded with blanks.

FIELD NAME	CONTENTS
Dataset Serial Number (6 bytes)	The volume serial number of the tape volume containing the dataset. For multi-volume datasets, this field contains the serial number of the first volume of the aggregate created at the same time. The serial number can be any 6 alphanumeric characters, normally numeric (000001-999999). If the number of characters is fewer than 6 characters, the code must be left-justified and followed by blanks.
Volume Sequence Number (4 bytes)	A number (0001-9999) that indicates the order of volume within the multi-volume group created at the same time. This number is always 0001 for a single volume dataset.
Dataset Sequence Number (4 bytes)	A number (0001-9999) that indicates the relative position of the dataset within a multi-dataset group. This number is always 0001 for a single dataset organization.
Generation Number (4 bytes)	If the dataset is part of a generation data group, this field contains a number from 0001 to 9999 indicating the absolute generation number (the first generation is recorded as 0001). If the dataset is not part of a generation data group, this field contains blanks.
Version Number Of Generation (2 bytes)	If the dataset is part of a generation data group, this field a number from 00 to 99 indicating the version number of the generation (the first version is recorded as 00). If the dataset is not part of a generation data group, this field contains blanks.
Creation Date (6 bytes)	Year and day of the year when the dataset was created. The date is shown in the format byydd where: b = blank yy = year(00-99) ddd = day(001-366)
Expiration Date (6 bytes)	Year and day of the year when the dataset may be scratched or overwritten. The data is shown in the format byydd where: b = blank yy = year (00-99) ddd = day (001-366)
Dataset Security (1 byte)	A code number indicating the security status of the dataset is as follows: 0 No password protection 1 Password protection Additional identification of the dataset is required before it can be read, written, or deleted (ignored if volume is RACF-defined) 3 Password protection Additional identification of the dataset is required before it can be read, written, or deleted (ignored if volume is RACF-defined).

FIELD NAME	CONTENTS
Block Count (6 bytes)	This field in the trailer label shows the number of data blocks in the dataset on the current volume. This field in the header label is always zeros (000000).
System Code (13 bytes)	Unique code that identifies the system.
Reserved (7 bytes)	Reserved for future use - should be recorded as blanks.

1.10.9 The IBM Standard Dataset Label 2 Format (HDR2, EOVS2, EOF2) always follows dataset label 1 and contains additional information about the associated dataset as described below:

Label Identifier (3 bytes)	Three characters that identify the label are as follows: HDR Header label (at the beginning of a dataset) EOV Trailer label (at the end of a tape volume, when the dataset continues on another volume) EOF Trailer label (at the end of a dataset).
Label Number (1 byte)	The relative position of this label within a set of labels of the same type; it is always a 2 for dataset label 2.
Record Format (1 byte)	An alphabetic character that indicates the format of records in the associated dataset as follows: F Fixed length V Variable length U Undefined length.
Block Length (5 bytes)	A number up to 32760 that indicates the block length, in bytes. Interpretation of the number depends on the following associated record format in Field 3: Format F - Block length (must be a multiple of the logical record length in Field 5) Format V - Maximum block length (including the 4 byte length indicator in the block) Format U - Maximum block length.
Record Length (5 bytes)	A number that indicates the record length, in bytes. Interpretation of the number depends on the following associated record format in Field 3: Format F - Logical record length Format V - Maximum logical record length (including the 4 byte length indicator in the records) Format U - Zeros.

Tape Density (1 byte)	A code indicating the record density of the tape, as follows: Recording Density DEN Value 9-Track Tape 3 1600 (PE) 4 6250 (GCR) PE - is for phase encoded mode GCR - is for group coded recording mode.
Dataset Position (1 byte)	A code, indicating a volume switch, is as follows: 0 - No volume switch has occurred 1 - A volume switch previously occurred.
Job/Job Step (17 bytes)	Identification of the job and job step that created the dataset. The first 8 bytes contain the name of the job, the ninth byte is a slash (/), and the final 8 bytes contain the name of the job step.
Tape Recording Technique (2 bytes)	A code or blanks indicating the tape recording technique used. This field is recorded as blanks for 9-track tape. The only technique available for 9-track tape is odd parity and no translation.
Control Characters (1 byte)	A code indicating whether a control character set was used to create the dataset and the type of control characters used: A Contains ASCII control characters M Contains machine control characters b Contains no control characters.
Reserved (1 byte)	Reserved for future use - should be recorded as blanks.
Block Attribute (1 byte)	A code indicating the block attribute used to create the dataset: B Blocked records S Spanned records R Blocked and spanned records b No blocked and no spanned records.
Reserved (8 bytes)	Bytes 40-42 - reserved for future use –should be blanks. Bytes 43-47 - (3420 tape units only) serial number of creating tape unit. Blank for other units.
Checkpoint Dataset (1 byte)	In VS2-Release 2, this byte contains the identifier character C if the dataset is a checkpoint dataset; the byte is blank if the dataset is not a check point dataset or in other releases of the VS systems.
Reserved (32 bytes)	Reserved for future use - should be recorded as blanks.

1.11 Testing Requirements

- 1.11.1 At least thirty (30) calendar days prior to any BellSouth software releases that affect the mechanized bill format, BellSouth shall send to AT&T bill data in the appropriate mechanized format for testing to ensure that the bills can be processed and that the bills comply with CBOS standards. After receipt of the test data from BellSouth, AT&T

will notify BellSouth at least ten (10) days prior to the software release implementation date of any processing problems as a result of the software changes. If the transmission fails to meet CBOS standards, BellSouth shall make the necessary corrections prior to implementation to meet such CBOS standards.

1.11.2 BellSouth shall provide to AT&T's Company Manager, located at 500 North Point Parkway, FLOC B1104B, Alpharetta, Georgia 30005, BellSouth's originating or state level company code so that it may be added to AT&T's internal tables at least thirty (30) calendar days prior to testing or prior to a change in BellSouth's originating or state level company code.

1.11.3 Test tapes containing the transmitted AT&T billing data and information will be sent during the testing period, per request, to the following location:

Test Tapes:	AT&T Attention: Bill Access Testing Coordinator 500 North Point Parkway FLOC B1104B Alpharetta, Georgia 30005
-------------	--

1.12 Additional Requirements

1.12.1 BellSouth agrees that if it transmits data to AT&T in a mechanized format, BellSouth will also comply with the following specifications which are not contained in CABS guidelines but which are necessary for AT&T to process billing information and data:

1.12.1.1 The BAN shall not contain embedded spaces or low values.

1.12.1.2 The Bill Date shall not contain spaces or non-numeric values.

1.12.1.3 Each bill must contain at least one detail record.

1.12.1.4 Any "From" Date should be less than the associated "Thru" Date and neither date can contain spaces.

1.12.1.5 The Invoice Number must not have embedded spaces or low values.

1.13 Bill Accuracy Certification

1.13.1 The Parties agree that in order to ensure the proper performance and integrity of the entire billing process, BellSouth will be responsible and accountable for transmitting to AT&T an accurate and current bill.

BellSouth agrees to implement control mechanisms and procedures to render a bill that accurately reflects the Billed Services ordered and used by AT&T. Accordingly, at AT&T's option on a connectivity by connectivity basis, AT&T and BellSouth agree to model, for the purposes of this Agreement, the process and methodology for access certification set forth in the Access Billing Supplier Quality Certification Operating Agreement dated August 13, 1993, executed by AT&T and BellSouth which governs certification of access bills for interLATA and intraLATA calls. At the point AT&T and BellSouth mutually agree that pre-certification is complete, all billing disputes will be handled pursuant to a billing supplier quality certification operating agreement to be executed by the Parties.

1.14 Payment Of Charges

1.14.1 Subject to the terms of this Agreement, AT&T and BellSouth will pay each other within thirty (30) calendar days from the Bill Date, or twenty (20) calendar days from the receipt of the bill, whichever is later. If the payment due date is a Sunday or is a Monday that has been designated a bank holiday by the Chase Manhattan Bank of New York (or such other bank as AT&T specifies), payment will be made the next business day. If the payment due date is a Saturday or is on a Tuesday, Wednesday, Thursday or Friday that has been designated a bank holiday by the Chase Manhattan Bank of New York (or such other bank as AT&T specifies), payment will be made on the preceding business day.

1.14.2 Payments shall be made in U.S. Dollars via electronic funds transfer ("EFT") to the other Party's bank account. At least thirty (30) days prior to the first transmission of billing data and information for payment, BellSouth and AT&T shall provide each other the name and address of its bank, its account and routing number and to whom billing payments should be made payable. If such banking information changes, each Party shall provide the other Party at least sixty (60) days written notice of the change and such notice shall include the new banking information. The Parties will render payment via EFT. AT&T will provide BellSouth with one address to which such payments shall be rendered and BellSouth will provide AT&T with one address to which such payments shall be rendered. In the event AT&T receives multiple bills from BellSouth which are payable on the same date, AT&T may remit one payment for the sum of all bills payable to BellSouth's bank account specified in this subsection if AT&T provides payment advice to BellSouth. Each Party shall provide the other Party with a contact person for the handling of billing payment questions or problems.

1.15 Billing Disputes

- 1.15.1 On a connectivity by connectivity basis and until such time as a precertification process is in place, each party agrees to notify the other party in writing upon the discovery of a billing dispute. The disputing party agrees to provide the billing party sufficient documentation to investigate the dispute and may withhold any disputed amounts supported by such documentation. Until documentation is provided all outstanding billed amounts will be considered past due. In the event of a billing dispute, the parties will endeavor to resolve the dispute within sixty (60) calendar days of the dispute notification date. Resolution of the dispute is expected to occur at the first level of management resulting in a recommendation for settlement of the dispute.
- 1.15.2 If the issues are not resolved within the allotted time frame, each of the parties shall appoint a designated representative who has authority to settle the dispute and who is at a higher level of management than the persons with direct responsibility for administration of this Agreement. The designated representatives shall meet as often as they reasonably deem necessary in order to discuss the dispute and negotiate in good faith in an effort to resolve such dispute. The specific format for such discussions will be left to the discretion of the designated representatives, however all reasonable requests for relevant information made by one Party to the other Party shall be honored.
- 1.15.3 If the Parties are unable to resolve issues related to the disputed amounts within forty-five (45) days after the parties' appointment of designated representatives, the dispute will be resolved in accordance with the dispute resolution procedure set forth in Section 16 of the General Terms and Conditions of this Agreement, incorporated herein by this reference.
- 1.15.4 If a party disputes a charge and does not pay such charge by the payment due date, such charges shall be subject to late payment charges as set forth in Section 1.16 of this Attachment 6. If a party disputes charges and the dispute is resolved in favor of such party, the other party shall credit the bill of the disputing party for the amount of the disputed charges along with any late payment charges assessed no later than the second Bill Date after the resolution of the dispute. Accordingly, if a party disputes charges and the dispute is resolved in favor of the other party, the disputing party shall pay the other party the amount of the disputed charges and any associated late payment charges assessed no later than the second bill payment due date after the resolution of the dispute.

1.16 Late Payment Charges

1.16.1 If either Party fails to remit payment for any charges described in this Attachment 6 by the payment due date, or if a payment or any portion of a payment is received by either Party after the payment due date, or if a payment or any portion of a payment is received in funds which are not immediately available to the other Party, then a late payment penalty shall be assessed. For bills rendered by BellSouth for payment by AT&T, the late payment charge shall be calculated based on the portion of the payment not received by the payment due date times the late factor as set forth in the following BellSouth tariffs, based upon the service for which payment was not received: for general subscriber services, Section A2 of the General Subscriber Services Tariff; for private line service, Section B2 of the Private Line Service Tariff; and for access service, Section E2 of the Access Service Tariff. For bills rendered by AT&T for payment by BellSouth the late payment charge shall be calculated based on the portion of the payment not received by the payment date times the lesser of (i) .one and one-half percent (1 ½%) per month or (ii) the highest interest rate (in decimal value) which may be charged by law for commercial transactions, compounded daily for the number of days from the payment date to and including the date that payment is actual made. In no event, however, shall interest be assessed by AT&T on any previously assessed late payment charges. BellSouth shall only assess interest on previously assessed late payment charges in a state where it has the authority pursuant to its tariffs. Bill disputes shall not be submitted by either party for any charge on or after one (1) year following the bill date of the bill on which the charge first appears.

1.17 Discontinuance of Service

1.17.1 The procedures for discontinuing service to an end user are as follows:

1.17.1.1 Where possible, BellSouth will deny service to AT&T's end user on behalf of, and at the request of, AT&T. Upon restoration of the end user's service, restoral charges will apply and will be the responsibility of AT&T.

1.17.1.2 At the request of AT&T, BellSouth will disconnect an AT&T end user.

1.17.1.3 All requests by AT&T for denial or disconnection of an end user for nonpayment must be in writing.

1.17.1.4 AT&T will be made solely responsible for notifying the end user of the proposed disconnection of the service.

1.17.1.5 BellSouth may disconnect and reuse facilities when the facility is in a denied state and BellSouth has received an order to establish new

service or transfer of service from an end user or an end user's CLEC at the same address served by the denied facility.

- 1.17.2 The procedures for discontinuing service to AT&T are as follows:
 - 1.17.2.1 BellSouth reserves the right to suspend or terminate service for nonpayment of undisputed amounts or in the event of prohibited, unlawful or improper use of the facilities or service.
 - 1.17.2.2 If payment of undisputed amounts is not received by the bill day in the month after the original bill day, BellSouth may provide written notice to AT&T, that additional applications for service will be refused and that any pending orders for service will not be completed if payment of undisputed amounts is not received by the fifteenth day following the date of the notice. In addition BellSouth may, at the same time, give thirty days notice to the person designated by AT&T to receive notices of noncompliance, and discontinue the provision of existing services to AT&T at any time thereafter.
 - 1.17.2.3 In the case of such discontinuance, all billed undisputed charges, as well as applicable termination charges, shall become due.
 - 1.17.2.4 If BellSouth does not discontinue the provision of the services involved on the date specified in the thirty (30) days' notice and AT&T's noncompliance continues, nothing contained herein shall preclude BellSouth's right to discontinue the provision of the services to AT&T without further notice.
 - 1.17.2.5 If payment of undisputed charges is not received or arrangements made for payment by the date given in the written notification, AT&T's services will be discontinued. Upon discontinuance of service on a AT&T's account, service to AT&T's end users will be denied. BellSouth will also reestablish service at the request of the end user or AT&T upon payment of the appropriate connection fee and subject to BellSouth's normal application procedures. AT&T is solely responsible for notifying the end user of the proposed disconnection of the service.
 - 17.2.6 If within fifteen days after an end user's service has been denied, AT&T has not contacted BellSouth in reference to restoring service, the end user's service will be disconnected.

1.18 Adjustments

- 1.18.1 Subject to the terms of this Attachment 6, BellSouth will adjust incorrect billing charges to AT&T. Such adjustments shall be set forth in the appropriate section of the bill pursuant to CBOS or CLUB/EDI standards.

1.19 Revenue Protection

- 1.19.1 Where BellSouth services are being resold and where AT&T is using a BellSouth port, AT&T will have the use of all present and future fraud prevention or revenue protection features, including prevention, detection, or control functionality embedded within any of the network elements available to BellSouth. These features include, but are not limited to, screening codes, call blocking of international, 900, and 976 numbers.
- 1.19.2 The Party causing a provisioning, maintenance or signal network routing error that results in uncollectible or unbillable revenues to the other Party shall be liable for the amount of the revenues lost by the Party unable to bill or collect the revenues less costs that would have been incurred from gaining such revenues.
- 1.19.3 Uncollectible or unbillable revenues resulting from the accidental or malicious alteration of software underlying Network Elements or their subtending operational support systems by unauthorized third parties shall be the responsibility of the Party having administrative control of access to said Network Element or operational support system software to the extent such unbillable or uncollectible revenue results from the gross negligence or willful act or omission of the Party having such administrative control.
- 1.19.4 BellSouth shall be responsible for any uncollectible or unbillable revenues resulting from the unauthorized physical attachment to loop facilities from the Main Distribution Frame up to and including the Network Interface Device, including clip-on fraud to the extent such unbillable or uncollectible revenue results from the gross negligence or willful act or omission of BellSouth. BellSouth shall provide soft dial tone to allow only the completion of calls to final termination points required by law.

2. PROVISION OF CUSTOMER USAGE DATA

2.1 Introduction

- 2.1.1 This Section sets forth the terms and conditions for BellSouth's provision of Recorded Usage Data to AT&T.
- 2.1.2 Line Information Database ("LIDB") is a database system designed to provide for validation of calling card and other billing information. LIDB provides screening validation on operator assisted calls on billing number records and is offered under a separate agreement. The Parties' agreement relating to LIDB Storage is included as Exhibit A to this Attachment 6, incorporated herein by this reference.

- 2.1.3 RAO Hosting is the process by which a telecommunications company agrees to “host” another company solely for the purpose of message exchange over the Centralized Message Distribution System (“CMDS”). RAO Hosting includes the following: RAO Code Assignment, Message Exchange via the CMDS system, and Inter-Company Settlements. The Parties’ RAO Hosting Agreement is included as Exhibit B to this Attachment 6, incorporated herein by this reference.
- 2.1.4 Optional Daily Usage File (“ODUF”) contains billable messages that were carried over the BellSouth Network and processed in the BellSouth Billing System, but billed to the AT&T account. The Parties’ ODUF agreement is included as Exhibit C to this Attachment 6, incorporated herein by this reference.
- 2.1.5 Enhanced Optional Daily Usage File (“EODUF”) provides usage data for local calls originating from resold Flat Rate Business and Residential Lines. The Parties’ EODUF agreement is included as Exhibit D to this Attachment 6, incorporated herein by this reference.
- 2.1.6 Access Daily Usage File (“ADUF”) contains access messages associated with a port that AT&T has purchased from BellSouth. The Parties’ ADUF agreement is included as Exhibit E to this Attachment 6, incorporated herein by this reference.

3. LOCAL ACCOUNT MAINTENANCE

- 3.1 When BellSouth provides local switching to AT&T (e.g., where AT&T is reselling BellSouth’s services or is employing loop port combination to provide local service) BellSouth shall provide local account maintenance information and service as described herein.
- 3.2 When notified by a CLEC (or from the end user to change to BellSouth service) that an AT&T end user has switched its local service to the other CLEC’s service (or to BellSouth), BellSouth shall send AT&T a loss notification message to inform AT&T that its end user has switched to another CLEC (or to BellSouth). The Parties agree to utilize LSOG4 or the most current industry ordering guideline standard established by the OBF that contains the loss notification message.
- 3.3 BellSouth shall send loss notification messages to AT&T six (6) days a week using the applicable release of EDI as the electronic medium for transmitting the loss notification message.
- 3.4 BellSouth shall accept and process intraLATA and interLATA PIC changes sent by AT&T. When an AT&T local end user switches its IXC, AT&T will enter the PIC change into the current local order

system, and will generate an intraLATA or interLATA PIC Service Change Order that will be sent to BellSouth for provisioning over the existing ordering gateway.

- 3.5 When AT&T is notified by an intraLATA or interLATA carrier using a Transaction Code ("TC") "01" PIC order record than an AT&T local end user has changed its intraLATA or interLATA PIC, BellSouth shall reject the order and notify the intraLATA or interLATA carrier that a CARE PIC record should be sent to AT&T. BellSouth shall notify the intraLATA or interLATA carrier by creating a '3148' (for resale or UNE-P) or a '3150' (for ported numbers) reject transaction record, and shall populate the AT&T provided AT&T Operating Company Code on the reject record. The intraLATA and interLATA carrier should redirect the TC01 order to AT&T for processing the PIC.

LINE INFORMATION DATA BASE (“LIDB”)
STORAGE AGREEMENT

I. SCOPE

- 1.1 This Exhibit sets forth the terms and conditions pursuant to which BellSouth agrees to store in its LIDB certain information at the request of AT&T and pursuant to which BellSouth, its LIDB customers and AT&T shall have access to such information. AT&T understands that BellSouth provides access to information in its LIDB to various telecommunications service providers pursuant to applicable tariffs and agrees that information stored at the request of Local Exchange Carrier, pursuant to this Exhibit, shall be available to those telecommunications service providers.
- 1.2 Definitions
- 1.2.1 Billing number - a number used by BellSouth for the purpose of identifying an account liable for charges. This number may be a line or a special billing number.
- 1.2.2 Line number - a ten-digit number assigned by BellSouth that identifies a telephone line associated with a resold local exchange service, or with a SPNP arrangement.
- 1.2.3 Special billing number - a ten-digit number that identifies a billing account established by BellSouth in connection with a resold local exchange service or with a SPNP arrangement.
- 1.2.4 Calling Card number - a billing number plus PIN number assigned by BellSouth.
- 1.2.5 PIN number - a four digit security code assigned by BellSouth which is added to a billing number to compose a fourteen digit calling card number.
- 1.2.6 Toll billing exception indicator - associated with a billing number to indicate that it is considered invalid for billing of collect calls or third number calls or both, by the Local Exchange Company.

Exhibit A, Page 2 of 5

- 1.2.7 Billed Number Screening - refers to the activity of determining whether a toll billing exception indicator is present for a particular billing number.
- 1.2.8 Calling Card Validation - refers to the activity of determining whether a particular calling card number exists as stated or otherwise provided by a caller.
- 1.2.9 Billing number information - information about billing number or Calling Card number as assigned by BellSouth and toll billing exception indicator provided to BellSouth by the Local Exchange Company.
- 1.3 LIDB is accessed for the following purposes:
- Billed Number Screening
 - Calling Card Validation
 - Fraud Control
- 1.4.1 BellSouth will provide seven days per week, 24-hours per day, fraud monitoring on Calling Cards, bill-to-third and collect calls made to numbers in BellSouth's LIDB, provided that such information is included in the LIDB query. BellSouth will establish fraud alert thresholds and will notify AT&T within 2 hours of fraud alerts so that the AT&T may take action it deems appropriate. At AT&T's request, BellSouth shall block and restrict calling card, third party billing and collect call, and validation in its LIDB within two (2) hours of receiving AT&T's request. Local Exchange Company understands and agrees BellSouth will administer all data stored in the LIDB, including the data provided by Local Exchange Company pursuant to this Exhibit, in the same manner as BellSouth's data for BellSouth's end users. BellSouth shall not be responsible to AT&T for any lost revenue which may result from BellSouth's administration of the LIDB pursuant to its established practices and procedures as they exist and as they may be changed by BellSouth in its sole discretion from time to time.
- 1.4.2 AT&T understands that BellSouth currently has in effect numerous billing and collection agreements with various interexchange carriers and billing clearing houses. AT&T further understands that these billing and collection customers of BellSouth query BellSouth's LIDB to determine whether to accept various billing options from end users. Additionally, AT&T understands that presently BellSouth has no method to differentiate between BellSouth's own billing and line data in

Exhibit A, Page 3 of 5

the LIDB and such data which it includes in the LIDB on AT&T's behalf pursuant to this Exhibit. Therefore, until such time as BellSouth can and does implement in its LIDB and its supporting systems the means to differentiate AT&T's data from BellSouth's data and the Parties execute appropriate amendments hereto, the following terms and conditions shall apply:

- 1.4.2.1 AT&T agrees that it will accept responsibility for telecommunications services billed by BellSouth for its billing and collection customers for AT&T's end user accounts which are resident in LIDB pursuant to this Exhibit. AT&T's authorizes BellSouth to place such charges on AT&T's bill from BellSouth and agrees that it shall pay all such charges. Charges for which AT&T hereby takes responsibility include, but are not limited to, collect and third number calls.
- 1.4.2.2 Charges for such services shall appear on a separate BellSouth bill page identified with the name of the entity for which BellSouth is billing the charge.
- 1.4.2.3 AT&T shall have the responsibility to render a billing statement to its end users for these charges, but AT&T's obligation to pay BellSouth for the charges billed shall be independent of whether AT&T is able or not to collect from the AT&T's end users.
- 1.4.2.4 BellSouth shall not become involved in any disputes between AT&T and the entities for which BellSouth performs billing and collection. BellSouth will not issue adjustments for charges billed on behalf of an entity to AT&T. It shall be the responsibility of the AT&T and the other entity to negotiate and arrange for any appropriate adjustments.

2. FEES FOR SERVICE AND TAXES

- 2.1 AT&T will not be charged a fee for storage services provided by BellSouth to AT&T, as described in Section I of this Exhibit.

3. MISCELLANEOUS

- 3.1 It is understood and agreed to by the parties that BellSouth may provide similar services to other companies.
- 3.2 All terms, conditions and operations under this Agreement shall be performed in accordance with, and subject to, all applicable local, state

Exhibit A, Page 4 of 5

or federal legal and regulatory tariffs, rulings, and other requirements of the federal courts, the U. S. Department of Justice and state and federal regulatory agencies. Nothing in this Agreement shall be construed to cause either party to violate any such legal or regulatory requirement and either party's obligation to perform shall be subject to all such requirements.

- 3.3 This Exhibit constitutes the entire agreement between AT&T and BellSouth which supersedes all prior agreements or contracts, oral or written representations, statements, negotiations, understandings, proposals and undertakings with respect to the subject matter hereof.

4. RESALE

- 4.1 This Section sets forth the terms and conditions for AT&T's provision of billing number information to BellSouth for inclusion in BellSouth's LIDB. BellSouth will store in its LIDB the billing number information provided by AT&T, and BellSouth will provide responses to on-line, call-by-call queries to this information for purposes specified in Section 1.3 of this Exhibit A.

4.2 Responsibilities of Parties

- 4.2.1 BellSouth will include billing number information associated with resold exchange lines or SPNP arrangements in its LIDB. The AT&T will request any toll billing exceptions via the Local Service Request ("LSR") form used to order resold exchange lines, or the SPNP service request form used to order SPNP arrangements.

- 4.2.2 Under normal operating conditions, BellSouth shall include the billing number information in its LIDB upon completion of the service order establishing either the resold local exchange service or the SPNP arrangement, provided that BellSouth shall not be held responsible for any delay or failure in performance to the extent such delay or failure is caused by circumstances or conditions beyond BellSouth's reasonable control. BellSouth will store in its LIDB an unlimited volume of the working telephone numbers associated with either the resold local exchange lines or the SPNP arrangements. For resold local exchange lines or for SPNP arrangements, BellSouth will issue line-based calling cards only in the name of AT&T. BellSouth will not issue line-based calling cards in the name of AT&T's individual end users. In the event

Exhibit A, Page 5 of 5

that AT&T wants to include calling card numbers assigned by AT&T in the BellSouth LIDB, a separate agreement is required.

- 4.2.3 BellSouth will provide responses to on-line, call-by-call queries to the stored information for the specific purposes listed in the next paragraph.
- 4.2.4 BellSouth is authorized to use the billing number information to perform the following functions for authorized users on an on-line basis:
 - 4.2.4.1 Validate a 14 digit Calling Card number where the first 10 digits are a line number or special billing number assigned by BellSouth, and where the last four digits (PIN) are a security code assigned by BellSouth.
 - 4.2.4.2 Determine whether the AT&T has identified the billing number as one which should not be billed for collect or third number calls, or both.

RAO HOSTING

- 1 RAO Hosting, Calling Card and Third Number Settlement System (“CATS”) and Non-Intercompany Settlement System (“NICS”) services provided to AT&T by BellSouth will be in accordance with the methods and practices regularly adopted and applied by BellSouth to its own operations during the term of this Agreement, including such revisions as may be made from time to time by BellSouth. BellSouth shall provide AT&T with notice of such revisions sixty (60) days prior to implementation.
- 2 AT&T shall furnish all relevant information required by BellSouth for the provision of RAO Hosting, CATS and NICS.
- 3 Applicable compensation amounts will be billed by BellSouth to AT&T on a monthly basis in arrears. Amounts due from one Party to the other (excluding adjustments) are payable within thirty (30) days of receipt of the billing statement.
- 4 AT&T must have its own unique RAO code. Requests for establishment of RAO status where BellSouth is the selected Centralized Message Distribution System (“CMDS”) interfacing host, require written notification from AT&T to the BellSouth RAO Hosting coordinator at least eight (8) weeks prior to the proposed effective date. The proposed effective date will be mutually agreed upon between the Parties with consideration given to time necessary for the completion of required Telcordia (formerly BellCore) functions. BellSouth will request the assignment of an RAO code from its connecting contractor, currently Telcordia (formerly BellCore), on behalf of AT&T and will coordinate all associated conversion activities.
- 5 BellSouth will receive messages from AT&T that are to be processed by BellSouth, another LEC or CLEC in the BellSouth region or a LEC outside the BellSouth region.
- 6 BellSouth will perform invoice sequence checking, standard EMI format editing, and balancing of message data with the EMI trailer record counts on all data received from AT&T.
- 7 All data received from AT&T that is to be processed or billed by another LEC or CLEC within the BellSouth region will be distributed to

Exhibit B, Page 2 of 5

that LEC or CLEC in accordance with the agreement(s) which may be in effect between BellSouth and the involved LEC or CLEC.

- 8 All data received from AT&T that is to be placed on the CMDS network for distribution outside the BellSouth region will be handled in accordance with the agreement(s) which may be in effect between BellSouth and its connecting contractor [currently Telcordia (formerly BellCore)].
- 9 BellSouth will receive messages from the CMDS network that are destined to be processed by AT&T and will forward them to AT&T on a daily basis.
- 10 Transmission of message data between BellSouth and AT&T will be via CONNECT: Direct.
- 11 All messages and related data exchanged between BellSouth and AT&T will be formatted in accordance with accepted industry standards for EMI formatted records and packed between appropriate EMI header and trailer records, also in accordance with accepted industry standards.
- 12 AT&T will ensure that the recorded message detail necessary to recreate files provided to BellSouth will be maintained for back-up purposes for a period of three (3) calendar months beyond the related message dates.
- 13 Should it become necessary for AT&T to send data to BellSouth more than sixty (60) days past the message date(s), AT&T will notify BellSouth in advance of the transmission of the data. If there will be impacts outside the BellSouth region, BellSouth will work with its connecting contractor and AT&T to notify all affected Parties.
- 14 In the event that data to be exchanged between the two Parties should become lost or destroyed, both Parties will work together to determine the source of the problem. Once the cause of the problem has been jointly determined and the responsible Party (BellSouth or AT&T) identified and agreed to, the company responsible for creating the data (BellSouth or AT&T) will make every effort to have the affected data restored and retransmitted. If the data cannot be retrieved, the responsible Party will be liable to the other Party for any resulting lost revenue. Lost revenue may be a combination of revenues that could

Exhibit B, Page 3 of 5

not be billed to the end users and associated access revenues. Both Parties will work together to estimate the revenue amount based upon historical data through a method mutually agreed upon. The resulting estimated revenue loss will be paid by the responsible Party to the other Party within three (3) calendar months of the date of problem resolution, or as mutually agreed upon by the Parties.

- 15 Should an error be detected by the EMI format edits performed by BellSouth on data received from AT&T, the entire pack containing the affected data will not be processed by BellSouth. BellSouth will notify AT&T of the error condition. AT&T will correct the error(s) and will resend the entire pack to BellSouth for processing. In the event that an out-of-sequence condition occurs on subsequent packs, AT&T will resend these packs to BellSouth after the pack containing the error has been successfully reprocessed by BellSouth.
- 16 In association with message distribution service, BellSouth will provide AT&T with associated intercompany settlements reports (CATS and NICS) as appropriate.
- 17 In no case shall either Party be liable to the other for any direct or consequential damages incurred as a result of the obligations set out in this agreement.
- 18 RAO Compensation
- 18.1 Rates for message distribution service provided by BellSouth for AT&T are as set forth in Exhibit F to this Attachment 6, incorporated herein by this reference.
- 18.2 Rates for data transmission associated with message distribution service are as set forth in Exhibit F to this Attachment 6, incorporated herein by this reference.
- 18.3 Data circuits (private line or dial-up) will be required between BellSouth and AT&T for the purpose of data transmission. Where a dedicated line is required, AT&T will be responsible for ordering the circuit, overseeing its installation and coordinating the installation with BellSouth. AT&T will also be responsible for any charges associated with this line. Equipment required on the BellSouth end to attach the line to the mainframe computer and to transmit successfully ongoing will be negotiated on a case by case basis. Where a dial-up facility is

Exhibit B, Page 4 of 5

required, dial circuits will be installed in the BellSouth data center by BellSouth and the associated charges assessed to AT&T. Additionally, all message toll charges associated with the use of the dial circuit by AT&T will be the responsibility of AT&T. Associated equipment on the BellSouth end, including a modem, will be negotiated on a case by case basis between the Parties.

18.4 All equipment, including modems and software, that is required on AT&T's end for the purpose of data transmission will be the responsibility of AT&T.

19 Intercompany Settlements Messages

19.1 This Section addresses the settlement of revenues associated with traffic originated from or billed by AT&T as a facilities based provider of local exchange telecommunications services outside the BellSouth region. Only traffic that originates in one Bell operating territory and bills in another Bell operating territory is included. Traffic that originates and bills within the same Bell operating territory will be settled on a local basis between AT&T and the involved company(ies), unless that company is participating in NICS.

19.2 Both traffic that originates outside the BellSouth region by AT&T and is billed within the BellSouth region, and traffic that originates within the BellSouth region and is billed outside the BellSouth region by AT&T, is covered by this Agreement (CATS). Also covered is traffic that either is originated by or billed by AT&T, involves a company other than AT&T, qualifies for inclusion in the CATS settlement, and is not originated or billed within the BellSouth region (NICS).

19.3 Once AT&T is operating within the BellSouth territory, revenues associated with calls originated and billed within the BellSouth region will be settled via Telcordia's (formerly BellCore), its successor or assign, NICS system.

19.4 BellSouth will receive the monthly NICS reports from Telcordia (formerly BellCore), its successor or assign, on behalf of AT&T. BellSouth will distribute copies of these reports to AT&T on a monthly basis.

19.5 BellSouth will receive the monthly CATS reports from Telcordia (formerly BellCore), its successor or assign, on behalf of AT&T.

Exhibit B, Page 5 of 5

BellSouth will distribute copies of these reports to AT&T on a monthly basis.

- 19.6 BellSouth will collect the revenue earned by AT&T from the Bell operating company in whose territory the messages are billed (CATS), less a per message billing and collection fee of five cents (\$0.05), on behalf of AT&T. BellSouth will remit the revenue billed by AT&T to the Bell operating company in whose territory the messages originated, less a per message billing and collection fee of five cents (\$0.05), on behalf of AT&T. These two amounts will be netted together by BellSouth and the resulting charge or credit issued to AT&T via a monthly Carrier Access Billing System ("CABS") miscellaneous bill.
- 19.7 BellSouth will collect the revenue earned by AT&T within the BellSouth territory from another CLEC also within the BellSouth territory (NICS) where the messages are billed, less a per message billing and collection fee of five cents (\$0.05), on behalf of AT&T. BellSouth will remit the revenue billed by AT&T within the BellSouth region to the CLEC also within the BellSouth region, where the messages originated, less a per message billing and collection fee of five cents (\$0.05). These two amounts will be netted together by BellSouth and the resulting charge or credit issued to AT&T via a monthly CABS miscellaneous bill.
- 19.8 BellSouth and AT&T agree that monthly netted amounts of less than fifty dollars (\$50.00) will not be settled.

Exhibit C, Page 1 of 4

OPTIONAL DAILY USAGE FILE

1 Upon written request from AT&T, BellSouth will provide the Optional Daily Usage File (“ODUF”) service to AT&T pursuant to the terms and conditions set forth in this section.

2 AT&T shall furnish all relevant information required by BellSouth for the provision of the Optional Daily Usage File.

3 The Optional Daily Usage Feed will contain billable messages that were carried over the BellSouth Network and processed in the BellSouth Billing System, but billed to an AT&T end user.

Charges for delivery of the Optional Daily Usage File will appear on the AT&Ts’ monthly bills. The charges are as set forth in Exhibit A to this Attachment 6, incorporated herein by this reference.

4 The Optional Daily Usage Feed will contain both rated and unrated messages. All messages will be in the standard Alliance for Telecommunications Industry Solutions (“ATIS”) EMI record format.

5 Messages that error in the billing system of the AT&T will be the responsibility of the AT&T. If, however, the AT&T should encounter significant volumes of errored messages that prevent processing by the AT&T within its systems, BellSouth will work with the AT&T to determine the source of the errors and the appropriate resolution.

6 The following specifications shall apply to the Optional Daily Usage Feed.

6.1 Usage To Be Transmitted

6.1.1 The following messages recorded by BellSouth will be transmitted to the AT&T:

- message recording for per use/per activation type services (examples: Three Way Calling, Verify, Interrupt, Call Return, ETC.)
- measured billable Local
- Directory Assistance messages
- intraLATA Toll
- WATS & 800 Service

- N11
- Information Service Provider Messages
- Operator Services Messages
- Operator Services Message Attempted Calls (UNE only)
- Credit/Cancel Records
- Usage for Voice Mail Message Service

- 6.1.2 Rated Incollects (originated in BellSouth and from other companies) can also be on Optional Daily Usage File. Rated Incollects will be intermingled with BellSouth recorded rated and unrated usage. Rated Incollects will not be packed separately.
- 6.1.3 BellSouth will perform duplicate record checks on records processed to Optional Daily Usage File. Any duplicate messages detected will be deleted and not sent to AT&T.
- 6.1.4 In the event that AT&T detects a duplicate on Optional Daily Usage File they receive from BellSouth, AT&T will drop the duplicate message (AT&T will not return the duplicate to BellSouth).
- 6.2 Physical File Characteristics
- 6.2.1 The Optional Daily Usage File will be distributed to AT&T via an agreed medium with CONNECT:Direct being the preferred transport method. The Daily Usage Feed will be a variable block format (2476) with an LRECL of 2472. The data on the Daily Usage Feed will be in a non-compacted EMI format (175 byte format plus modules). It will be created on a daily basis (Monday through Friday except holidays). Details such as dataset name and delivery schedule will be addressed during negotiations of the distribution medium. There will be a maximum of one dataset per workday per OCN.
- 6.2.2 Data circuits (private line or dial-up) may be required between BellSouth and AT&T for the purpose of data transmission. Where a dedicated line is required, AT&T will be responsible for ordering the circuit, overseeing its installation and coordinating the installation with BellSouth. AT&T will also be responsible for any charges associated with this line. Equipment required on the BellSouth end to attach the line to the mainframe computer and to transmit successfully ongoing will be negotiated on a case by case basis. Where a dial-up facility is required, dial circuits will be installed in the BellSouth data center by

Exhibit C, Page 3 of 4

BellSouth and the associated charges assessed to AT&T. Additionally, all message toll charges associated with the use of the dial circuit by AT&T will be the responsibility of AT&T. Associated equipment on the BellSouth end, including a modem, will be negotiated on a case by case basis between the parties. All equipment, including modems and software, that is required on AT&T end for the purpose of data transmission will be the responsibility of AT&T.

6.3 Packing Specifications

6.3.1 A pack will contain a minimum of one message record or a maximum of 99,999 message records plus a pack header record and a pack trailer record. One transmission can contain a maximum of 99 packs and a minimum of one pack.

6.3.2 The OCN, From RAO, and Invoice Number will control the invoice sequencing. The From RAO will be used to identify to AT&T which BellSouth RAO that is sending the message. BellSouth and AT&T will use the invoice sequencing to control data exchange. BellSouth will be notified of sequence failures identified by AT&T and resend the data as appropriate.

THE DATA WILL BE PACKED USING ATIS EMI RECORDS.

6.4 Pack Rejection

6.4.1 AT&T will notify BellSouth within one business day of rejected packs (via the mutually agreed medium). Packs could be rejected because of pack sequencing discrepancies or a critical edit failure on the Pack Header or Pack Trailer records (i.e., out-of-balance condition on grand totals, invalid data populated). Standard ATIS EMI Error Codes will be used. AT&T will not be required to return the actual rejected data to BellSouth. Rejected packs will be corrected and retransmitted to AT&T by BellSouth.

6.5 Control Data

AT&T will send one confirmation record per pack that is received from BellSouth. This confirmation record will indicate AT&T received the pack and the acceptance or rejection of the pack. Pack Status Code(s) will be populated using standard ATIS EMI error codes for

Exhibit C, Page 4 of 4

packs that were rejected by AT&T for reasons stated in the above section.

6.6 Testing

6.6.1 Upon request from AT&T, BellSouth shall send test files to AT&T for the Optional Daily Usage File. The parties agree to review and discuss the file's content and/or format. For testing of usage results, BellSouth shall request that AT&T set up a production (LIVE) file. The live test may consist of AT&T's employees making test calls for the types of services AT&T requests on the Optional Daily Usage File. These test calls are logged by AT&T, and the logs are provided to BellSouth. These logs will be used to verify the files. Testing will be completed within 30 calendar days from the date on which the initial test file was sent.

ENHANCED OPTIONAL DAILY USAGE FILE

1 Upon written request from AT&T, BellSouth will provide the Enhanced
Optional Daily Usage File (“EODUF”) service to AT&T pursuant to the
terms and conditions set forth in this section. EODUF will only be sent
to existing ODUF subscribers who request the EODUF option.

2 AT&T shall furnish all relevant information required by BellSouth for the
provision of the Enhanced Optional Daily Usage File.

3 The EODUF will provide usage data for local calls originating from
resold Flat Rate Business and Residential Lines.

4 Charges for delivery of the Enhanced Optional Daily Usage File will
appear on the AT&Ts’ monthly bills. The charges are as set forth in
Exhibit A to this Attachment 6, incorporated herein by this reference.

5 All messages will be in the standard Alliance for Telecommunications
Industry Solutions (“ATIS”) EMI record format.

6 Messages that error in the billing system of the AT&T will be the
responsibility of the AT&T. If, however, the AT&T should encounter
significant volumes of errored messages that prevent processing by
the AT&T within its systems, BellSouth will work with the AT&T to
determine the source of the errors and the appropriate resolution.

7 The following specifications shall apply to the Optional Daily Usage
Feed.

7.1 Usage To Be Transmitted

7.1.1 The following messages recorded by BellSouth will be transmitted to
AT&T:

Customer usage data for flat rated local call originating from CLEC end
user lines (1FB or 1FR). The EODUF record for flat rate messages will
include:

Date of Call
From Number
To Number
Connect Time
Conversation Time

Method of Recording
From RAO
Rate Class
Message Type
Billing Indicators
Bill to Number

- 7.1.2 BellSouth will perform duplicate record checks on EODUF records processed to Optional Daily Usage File. Any duplicate messages detected will be deleted and not sent to AT&T.
- 7.1.3 In the event that AT&T detects a duplicate on Enhanced Optional Daily Usage File they receive from BellSouth, AT&T will drop the duplicate message (AT&T will not return the duplicate to BellSouth).
- 7.2 Physical File Characteristics
- 7.2.1 The Enhanced Optional Daily Usage Feed will be distributed to AT&T over their existing ODUF feed. The EODUF messages will be intermingled among AT&T's ODUF messages. The EODUF will be a variable block format (2476) with an LRECL of 2472. The data on the EODUF will be in a non-compacted EMI format (175 byte format plus modules). It will be created on a daily basis (Monday through Friday except holidays).
- 7.2.2 Data circuits (private line or dial-up) may be required between BellSouth and AT&T for the purpose of data transmission. Where a dedicated line is required, AT&T will be responsible for ordering the circuit, overseeing its installation and coordinating the installation with BellSouth. AT&T will also be responsible for any charges associated with this line. Equipment required on the BellSouth end to attach the line to the mainframe computer and to transmit successfully ongoing will be negotiated on a case by case basis. Where a dial-up facility is required, dial circuits will be installed in the BellSouth data center by BellSouth and the associated charges assessed to AT&T. Additionally, all message toll charges associated with the use of the dial circuit by AT&T will be the responsibility of AT&T. Associated equipment on the BellSouth end, including a modem, will be negotiated on a case by case basis between the parties. All equipment, including modems and software, that is required on AT&T end for the purpose of data transmission will be the responsibility of AT&T.

7.3 Packing Specifications

7.3.1 A pack will contain a minimum of one message record or a maximum of 99,999 message records plus a pack header record and a pack trailer record. One transmission can contain a maximum of 99 packs and a minimum of one pack.

7.3.2 The Operating Company Number ("OCN"), From Revenue Accounting Office ("RAO"), and Invoice Number will control the invoice sequencing. The From RAO will be used to identify to AT&T which BellSouth RAO that is sending the message. BellSouth and AT&T will use the invoice sequencing to control data exchange. BellSouth will be notified of sequence failures identified by AT&T and resend the data as appropriate.

7.3.3 THE DATA WILL BE PACKED USING ATIS EMI RECORDS.

BELLSOUTH / ATT RATES
 ODU/FADU/F/CMDS
 Kentucky

CATEGORY	NOTES	RATE ELEMENT	Interim	Zone	BCS	USOC	RATES				OSS RATES										
							Rec	First	Advt	Nonrecurring	First	Advt	Nonrecurring	Disconnect	Svc Order Submitted per LSR	Svc Order Submitted per LSR	Incremental Change - Manual Electronic-1st	Incremental Change - Manual Electronic-Advt	Incremental Change - Manual Svc Order vs. Electronic-1st	Incremental Change - Manual Svc Order vs. Electronic-Advt	
ODU/F/ODU/FADU/F/CMDS																					
		ACCESS DAILY USAGE FILE (ADUF)*																			
		ADUF: Message Processing, per message				N/A	\$0.008045														
		ADUF: Data Transmission (CONNECT/DIRECT), per message				N/A	\$0.00012942														
		OPTIONAL DAILY USAGE FILE (ODUF)*																			
		ODUF: Recording, per message				N/A	\$0.2531340														
		ODUF: Message Processing, per message				N/A	\$0.00468980														
		ODUF: Message Processing, per Magnetic Tape Provisioned				N/A	\$48.78														
		ODUF: Data Transmission (CONNECT/DIRECT), per message				N/A	\$0.00010785														
		CENTRALIZED MESSAGE DISTRIBUTION SERVICE (CMDS)																			
		CMDS: Message Processing, per message				N/A	\$0.004														
		CMDS: Data Transmission (CONNECT/DIRECT), per message				N/A	\$0.001														
		NOTES: If no rate is defined in the contract, the rate for the specific service or function will be as set forth in applicable BellSouth tariff or as negotiated by the Parties upon request by either Party.																			
		Notes: It is the intent of the Parties that where applicable state commissions have approved rates for network elements and other services set forth in this Agreement as of the date hereof, such rates have been included in this exhibit, unless otherwise agreed to																			
	Interim																				

ATTACHMENT 7
INTERFACE REQUIREMENTS FOR ORDERING AND PROVISIONING,
MAINTENANCE AND REPAIR AND PRE-ORDERING

TABLE OF CONTENTS

1 **General Conditions** 3

2 **Pre-ordering**..... 5

3 **Ordering and Provisioning** 6

4 **Maintenance** 9

5 **Operational Readiness Test (“ORT”)** 10

**INTERFACE REQUIREMENTS FOR ORDERING AND PROVISIONING,
MAINTENANCE AND REPAIR AND PRE-ORDERING**

1 General Conditions

1.1 This Attachment 7 sets forth the terms and conditions under which BellSouth will provide AT&T access to the following BellSouth Operations Support Systems (“OSS”) functions. Access to these functions shall be via various interfaces and personnel and may be used by AT&T for pre-ordering, ordering, provisioning, maintenance and repair, and billing functions, which are supported by BellSouth databases, information, and personnel.

In addition to the electronic interfaces, BellSouth shall provide to AT&T any manual processes available to other CLECs for preordering, ordering, provisioning, and billing functions via BellSouth’s Local Service Center, and for repair and maintenance functions through BellSouth’s Local Operations Center. AT&T shall use its best efforts to utilize BellSouth’s electronic interfaces. However, should AT&T use manual processes, AT&T shall pay BellSouth the additional charges associated with these manual processes, as set forth in this Agreement.

Interfaces	Function
EDI, TAG, LENS, LENS99	Ordering
TAG, LENS, LENS99	Pre-order
EDI, TAG, LENS, LENS99, CSOTS	Provisioning
EBI (ECTA), TAFI	Maintenance and Repair
CABS, CRIS, BIBS	Billing and Recording

1.2 BellSouth will provide AT&T with access to the interfaces twenty-four (24) hours a day, seven (7) days a week, except for scheduled maintenance. BellSouth shall provide AT&T a minimum of fifteen (15) calendar days advance notice of any scheduled maintenance.

- 1.3 Downtime shall be scheduled when systems experience minimum usage.
- 1.4 Single Point of Contact (“SPOC”)
 - 1.4.1 BellSouth will provide a SPOC to provide technical support for the interfaces described herein. AT&T will also provide a SPOC for technical issues related to said interfaces.
 - 1.4.2 BellSouth will provide a SPOC for all ordering and provisioning contacts and order flow involved in the purchase and provisioning of BellSouth’s Services and Elements.
 - 1.4.3 BellSouth and AT&T will provide one another with toll-free contact numbers for their respective SPOCs.
- 1.5 The Parties agree that the current Change Control Process will be used to manage changes to existing interfaces, introduction of new interfaces and retirements of interfaces. AT&T and BellSouth agree to comply with the provisions of the current Change Control Process.
- 1.6 Throughout the term of this Agreement, the quality of the technology, equipment, facilities, processes, and techniques (including, without limitation, such new architecture, equipment, facilities, and interfaces as BellSouth may deploy) that BellSouth provides to AT&T under this Agreement must be at least equal in quality to that provided by BellSouth to itself and its affiliates. The service standards, measurements and performance incentives applicable to the interfaces are set forth in Attachment 9 of this Agreement, incorporated herein by this reference.
- 1.7 AT&T and BellSouth will utilize standard industry formats and data elements developed by the Alliance for Telecommunications Industry Solutions (“ATIS”), including without limitation to the Ordering and Billing Forum (“OBF”) (“ATIS and its associated committees”). Where standard industry formats and data elements are not developed by ATIS and its associated committees, AT&T and BellSouth will use the Change Control Process to address the specific format or data element requirements. When an ATIS and its associated committees standard or format is subsequently adopted, the Parties will utilize the Change Control Process to determine whether to continue to utilize the non-ATIS and its associated committees standard or format and when to implement the ATIS and its associated committees standard or format.

1.8 Subscription Functions. In cases where BellSouth performs subscription functions for an inter-exchange carrier [i.e., PIC, and LPIC changes via Customer Account Record Exchange ("CARE")], BellSouth will provide the affected inter-exchange carriers with the Operating Company Number ("OCN") of the local provider for the purpose of obtaining end user billing account and other end user information required under subscription requirements.

2 **Pre-ordering**

2.1 BellSouth shall provide access to the following pre-ordering functions: service address validation, telephone number selection, service and feature availability, due date information, dispatch and available installation appointments, PIC options for intraLATA and interLATA toll, loop qualification information and end user record information.

2.2 BellSouth shall provide AT&T with non-discriminatory access to the loop qualification information that is available to BellSouth, so that AT&T can make an independent judgment about whether the loop is capable of supporting the advanced services equipment that AT&T intends to install. Loop qualification information is defined as information, such as the composition of the loop material, including but not limited to: fiber optics or copper; the existence, location and type of any electronic or other equipment on the loop, including but not limited to, digital loop carrier or other remote concentration devices, feeder/distribution interfaces, bridge taps, load coils, pair-gain devices, disturbers in the same or adjacent binder groups; the loop length, including the length and location of each type of transmission media; the wire gauge(s) of the loop; and the electrical parameters of the loop, which may determine the suitability of the loop for various technologies.

2.3 BellSouth and AT&T will provide access to customer service record information where the Parties have the appropriate written authorization from the customer. Neither Party shall be required to present prior written authorization from each customer to the other Party before being allowed access to customer record information. Each Party will issue the other a blanket letter of authorization that states that AT&T and BellSouth will obtain the customer's permission before accessing customer records. Each Party shall retain the letters of authorization from its end users. If BellSouth desires to request a Customer Service Record ("CSR") for an AT&T customer, BellSouth is required to complete a Customer Service Information Query ("SCIQ") form and send via facsimile to AT&T. AT&T will accept CSR requests from BellSouth as acting agent for the customer (BellSouth should retain Letter of Authorization ("LOA") on file). AT&T will provide the

CSR and return via facsimile both the CSIQ form and the CSR within 48 hours or 2 business days, if the first of the two days falls on a Friday or a holiday. The provisioning of local service for the territory served by BellSouth is handled by AT&T's work center located in Atlanta, Georgia. The work center's facsimile telephone number is (404) 329-2169. Voice inquiries on the CSIQ should be directed to (404) 982-6611.

3 Ordering and Provisioning

- 3.1 BellSouth will recognize AT&T as the customer of record for services ordered by AT&T pursuant to this Agreement and will send all notices, invoices and pertinent information directly to AT&T. Except as otherwise specifically provided in this Agreement, AT&T shall be the single and sole point of contact for all AT&T end users.
- 3.2 Each Party shall refer all questions regarding the other Party's services or products directly to the other Party at a telephone number specified by the other Party. Each Party shall ensure that all their representatives who receive inquiries regarding the other Party's services or products: (i) provide such numbers to callers who inquire about the other Party's services or products; and (ii) do not in any way disparage or discriminate against the other Party, or its products or services.
- 3.3 BellSouth will provide access to ordering and provisioning functions via the interfaces as set forth in Section 1.1 of this Attachment 7. To order the services, AT&T will format the service request pursuant to the requirements of the interface utilized.
- 3.4 AT&T may submit, and BellSouth will accept, orders for Services and Elements on a single service request per end user account.
- 3.5 Currently all telecommunications services for resale; unbundled network elements, and interconnection are requested via BellSouth's Local Service Request ("LSR"). The exception to this is an industry wide exception dealing with ordering interconnection local trunking which is ordered on an Access Service Request ("ASR"). Ordering procedures are as outlined in the ordering guide posted on the web. Changes or additions to ordering procedures resulting from new Services and Elements shall be provided to AT&T through its account team and BellSouth's Internet website.
- 3.6 BellSouth shall provide all ordering and provisioning services to AT&T during the same business hours of operation that BellSouth provisions service to its affiliates or end users. Ordering and provisioning support

required by AT&T outside of these hours will be considered outside of normal business hours and will be subject to overtime billing.

- 3.7 If AT&T requests that BellSouth perform provisioning services at times or on days other than as required in the preceding sentence, BellSouth shall provide AT&T a quote for such services consistent with the provisions set forth in Attachment 2 of this Agreement, incorporated herein by this reference.
- 3.8 To ensure the most efficient use of facilities and resources, orders placed in the hold or pending status by AT&T will be held for a maximum of thirty (30) days from the date the order is placed on hold. After such time, if AT&T wishes to reinstate an order, AT&T may be required to submit a new service order.
- 3.9 Upon request from AT&T, and consistent with the provisions set forth in Attachment 2 of this Agreement, incorporated herein by this reference, BellSouth will provide an intercept referral message for any order for Services and Elements which include any new AT&T telephone number.
- 3.10 BellSouth will provide AT&T with a Firm Order Confirmation ("FOC") in compliance with the provisions of Attachment 9 of this Agreement, incorporated herein by this reference. The FOC will provide AT&T with the BellSouth order number, the negotiated service due date, telephone/circuit numbers (as applicable to the service). Additional specific data may also be provided, if appropriate.
- 3.11 AT&T will specify on each order its Desired Due Date ("DDD") for completion of that particular order. BellSouth shall not complete the order prior to DDD unless early turn-up is needed for testing purposes. BellSouth will notify AT&T if the DDD cannot be met. BellSouth will make best effort to meet the DDD for service requests.
- 3.12 If, during the provisioning visit to the AT&T end user premises, the AT&T end user requests additional work, BellSouth will contact AT&T for authorization to perform said work; will provide an estimate of time and materials required; will quote time and charges at the completion of the visit; and will notify AT&T if a subsequent visit is required.
- 3.13 Expedite and Escalation Procedures:
- 3.14 Requests for due dates that are earlier than the BellSouth offered date will be treated as an expedite request. In order to request an expedited due date, AT&T must request the expedite through the appropriate BellSouth service center on the appropriate service

request form. The BellSouth service center will coordinate the request internally with the appropriate groups within BellSouth in order to establish the date BellSouth will target as the offered date. The BellSouth service center will advise AT&T of this date on the FOC. If the date on the FOC does not meet AT&T's expedited request, AT&T may escalate to the appropriate center. BellSouth may bill expedite charges for expedited due date and will advise AT&T of any charges at the time the offered date is provided. BellSouth will provide an escalation list to AT&T containing the names and numbers of the appropriate personnel escalations are to be referred.

- 3.15 When AT&T orders Services and Elements pursuant to this Agreement, BellSouth shall provide notification electronically of any instances when (1) BellSouth's Committed Due Dates are in jeopardy of not being met by BellSouth on any service, (2) an order contains Rejections/Errors in any of the data element(s) fields, or (3) completion notice. When AT&T orders Services and Elements pursuant to this Agreement manually, BellSouth shall provide notification in the same manner in which it was sent of any instances when an order contains Rejections/Errors in any of the data element(s) fields. Any other notification or request for manual orders shall be available through BellSouth's Internet web site. Such notice will be made as soon as the jeopardy or reject is identified.
- 3.16 BellSouth and AT&T will perform co-operative testing (including trouble shooting to isolate problems) to test any Services and Elements purchased by AT&T pursuant to this Agreement in order to identify any performance problems identified at turn-up of the Services and Elements.
- 3.17 Where BellSouth provides installation on behalf of AT&T, BellSouth shall advise the AT&T end user to notify AT&T immediately if the AT&T end user requests a service change at the time of installation.
- 3.18 Upon AT&T's request through a Suspend/Restore Order, BellSouth shall suspend or restore the functionality of any Services and Elements provided pursuant to this Agreement.
- 3.19 Unless otherwise ordered by AT&T, when AT&T orders Services and Elements pursuant to this Agreement, all pre-assigned trunk or telephone numbers currently associated with those Services and Elements shall be retained without loss of switched based features where such features exist. AT&T shall be responsible for ensuring that associated functions (e.g., entries to databases and 911/E911 capability) are properly ordered or retained on the service request.

4 Maintenance

- 4.1 BellSouth shall perform maintenance functions for all Services and Elements provided pursuant to this Agreement in accordance with the terms and conditions of this Attachment 7 and as set forth in the Operational Understanding between BellSouth and AT&T Maintenance Centers ("Operational Understanding"), incorporated herein by this reference.
- 4.2 BellSouth shall provide AT&T with access to maintenance and repair function through its TAFI and EBI/ECTA interfaces.
- 4.2.1 The functionality provided through the EBI/ECTA interface shall be as set forth in the adopted applicable national standards.
- 4.2.2 When providing repair service for an AT&T end user, the TAFI interface shall allow AT&T personnel to: (i) enter a trouble ticket into the BellSouth maintenance system; (ii) track the current status on all AT&T end user repair tickets; (iii) receive "estimated time to repair" on a real time basis; (iv) if the trouble is feature related, display a list of the products and services that are programmed on a resold line or loop/port combination; (v) cause TAFI to perform an electronic test at the time of ticket entry and to display the test results on the screen; (vi) display pending orders associated with a resold line or loop/port combination; (vii) view the LMOS trouble report; (viii) query the switch serving the resold line or loop/port combination and view the current central office translations associated with said line or combination; (ix) view both abbreviated and extended trouble histories for a resold line or loop/port combination record in LMOS; (x) view the end user's resold line or loop/port combination record in LMOS; (xi) if the trouble is feature related, add or delete features to a resold line or loop/port combination; and (xii) route a repair ticket to the appropriate BellSouth work group for trouble handling (e.g., field dispatch, central office dispatch, further analysis of trouble by BellSouth personnel).
- 4.3 BellSouth service technicians shall provide to AT&T end users repair service that is at least equal in quality to that provided to BellSouth end users and trouble calls from AT&T shall receive response time priority that is at least equal to that of BellSouth end users and shall be handled on a "first come first served" basis regardless of whether the end user is an AT&T end user or a BellSouth end user.
- 4.4 For services provided through resale, BellSouth agrees to provide AT&T with scheduled maintenance for residence and small business end users consistent with the Operational Understanding. BellSouth agrees to provide AT&T written notification of Central Office

conversions and such conversions consistent with the Operational Understanding.

- 4.5 Maintenance charges for premises visits by BellSouth technicians shall be billed by AT&T to its end user, and not by BellSouth. The BellSouth technician shall, (i) contact AT&T for authorization, (ii) provide an estimate of time and materials required, (iii) quote time and charges at the completion of the repair visit to the end user, (iv) notify AT&T if a subsequent visit is required. BellSouth will bill maintenance charges for premises visits to AT&T.
- 4.6 When maintenance charges are incurred during premises visits, the BellSouth technician shall present the end user with a form that is consistent with Section 19 of the General Terms and Conditions of this Agreement, incorporated herein by this reference, detailing the time spent, the materials used, and an indication that the trouble has either been resolved, or that additional work will be necessary, in which case, BellSouth technician shall make an additional appointment with the end user. The BellSouth technician shall obtain the end user's signature upon said form, and then use the signed form to input maintenance charges into BellSouth's billing database.
- 4.7 BellSouth shall use best efforts to provide AT&T with prior notification, in the event that a BellSouth repair person is unable to keep a scheduled repair visit. If prior notice is not given and a scheduled repair visit is missed, AT&T may escalate to BellSouth for expedited repair or a revised estimated completion time.

5 Operational Readiness Test ("ORT")

- 5.1 Prior to initial live access to interface functionality and subject to mutual agreement, the Parties shall conduct Operational Readiness Testing ("ORT") which will allow for the testing of the systems, interfaces, and processes for the OSS functions.
- 5.2 For each OSS training class offered by BellSouth, AT&T shall receive at no cost, one seat per class per year. Job aids for updates to such OSS training information are available to AT&T on the BST Website
- 5.3 Prior to live system usage, AT&T will complete user education classes for BellSouth-provided interfaces that affect the BellSouth network.

ATTACHMENT 8

RIGHTS OF WAY (ROW), CONDUITS, AND POLE ATTACHMENTS

Between

BELLSOUTH TELECOMMUNICATIONS, INC.
(Licensor)

And

AT&T COMMUNICATIONS OF THE SOUTHERN STATES, INC.
(Licensee)

BELLSOUTH License Agreement Number - _____

CONTENTS

SECTION		PAGE
1	Definitions	3
2	Scope of Agreement	6
3	Requirements and Specifications	11
4	Additional Legal Requirements	18
5	Facilities and Licenses	19
6	Make-Ready Work	20
7	Application Forms and Fees	21
8	Processing of Applications	23
9	Issuance of Licenses	24
10	Construction of Licensee's Facilities	25
11	Use and Routine Maintenance of Licensee's Facilities	27
12	Modification and Replacement of Licensee's Facilities	29
13	Rearrangement of Facilities at request of Another	29
14	Emergency Repairs and Pole Replacements	31
15	Inspection by BellSouth of Licensee's Facilities	31
16	Notice of Noncompliance	31
17	Unauthorized Occupancy or Utilization of BellSouth's Facilities	33
18	Removal of Licensee's Facilities	34
19	Fees, Charges, and Billing	34
20	Advance Payment and Imputation	35
21	Assurance of Payment	35
22	Insurance	35
23	Authorization Not Exclusive	36
24	Assignment of Rights	36
25	Failure to Enforce	37
26	Dispute Resolution	37
27	Supersedure of Agreement(s)	37
EXHIBITS		
A	2000 FCC Formula Support Fees	38
B	Records Maintenance Centers	39

RIGHTS OF WAY (ROW), CONDUITS AND POLE ATTACHMENTS

This Attachment 8 sets forth the terms and conditions under which BellSouth shall afford to Licensee access to BellSouth's poles, ducts, conduits and rights-of-way, pursuant to the Act.

1. DEFINITIONS

Definitions in General. Except as the context otherwise requires, the terms defined in this Section shall, as used herein, have the meanings set forth in Sections 1.1 through 1.29.

- 1.1 Anchor. The term "anchor" refers to a device, structure, or assembly which stabilizes a pole and holds it in place. An anchor assembly may consist of a rod and fixed object or plate, typically embedded in the ground, which is attached to a guy strand or guy wire, which, in turn, is attached to the pole. The term "anchor" does not include the guy strand which connects the anchor to the pole and includes only those anchors which are owned by BellSouth, as distinguished from anchors which are owned and controlled by other persons or entities.
- 1.2 Anchor/guy strand. The term "anchor/guy strand" refers to supporting wires, typically stranded together, or other devices attached to a pole and connecting that pole to an anchor or to another pole for the purpose of increasing pole stability. The term "anchor/guy strand" includes, but is not limited to, strands sometimes referred to as "anchor strands," "down guys," "guy strands," and "pole-to-pole guys."
- 1.3 Communications Act of 1934. The terms "Communications Act of 1934" and "Communications Act" refer to the Communications Act of June 19, 1934, 48 Stat. 1064, as amended, including the provisions codified as 47 U.S.C. Sections 151, et seq. The Communications Act includes the Pole Attachment Act of 1978, as defined in Section 1.23 following.
- 1.4 Assigned. The term "assigned", when used with respect to conduit or duct space or pole attachment space, refers to any space in such conduit or duct or on such pole that is occupied by a telecommunications service provider or a municipal or other governmental authority. To ensure the judicious use of poles and conduits, space "assigned" to a telecommunications service provider must be physically occupied by the service provider, be it BellSouth or a new entrant, within twelve (12) months of the space being "assigned".
- 1.5 Available. The term "available", when used with respect to conduit or duct space or pole attachment space, refers to any usable space in such conduit or duct or on such pole not assigned to a specific provider at the applicable time.
- 1.6 Conduit occupancy. The terms "conduit occupancy" and "occupancy"

refer to the presence of wire, cable, optical conductors, or other facilities within any portion of BellSouth's conduit system.

- 1.7 Conduit system. The term "conduit system" refers to any combination of ducts, conduits, manholes, and handholes joined to form an integrated whole. In this Attachment 8, the term refers to conduit systems owned or controlled by BellSouth.
- 1.8 Cost. The term "cost" as used herein refers to charges made by BellSouth to Licensee for specific work performed, and shall be (a) the actual charges made by subcontractors to BellSouth for work and/or, (b) if the work was performed by BellSouth employees, the rates set forth in the Price Schedule of the General Terms and Conditions of BellSouth.
- 1.9 Duct. The term "duct" refers to a single enclosed tube, pipe, or channel for enclosing and carrying cables, wires, and other facilities. As used in this Attachment 8, the term "duct" includes "inner ducts" created by subdividing a duct into smaller channels.
- 1.10 Facilities. The terms "facility" and "facilities" refer to any property or equipment utilized in the provision of telecommunication services.
- 1.11 The acronym "FCC" refers to the Federal Communications Commission.
- 1.12 Inner-Duct. The term "inner-duct" refers to a pathway created by subdividing a duct into smaller channels.
- 1.13 Joint User. The term "joint user" refers to a utility which has entered into an agreement with BellSouth providing reciprocal rights of attachment of facilities owned by each party to the poles, ducts, conduits and rights-of-way owned by the other party.
- 1.14 Licensee. The term "licensee" refers to a person or entity which has entered or may enter into an agreement or arrangement with BellSouth permitting such person or entity to place its facilities in BellSouth's conduit system or attach its facilities to BellSouth's poles or anchors.
- 1.15 Lashing. The term "lashing" refers to the attachment of a licensee's sheath or inner-duct to a supporting strand.
- 1.16 License. The term "license" refers to any license issued pursuant to this Attachment 8 and may, if the context requires, refer to conduit occupancy or pole attachment licenses issued by BellSouth prior to the date of this Attachment 8.
- 1.17 Make-Ready work. The term "make-ready work" refers to all work performed or to be performed to prepare BellSouth's conduit systems, poles or anchors and related facilities for the requested occupancy or attachment of Licensee's facilities. "Make-Ready work" includes, but is not limited to, clearing obstructions (e.g., by "rodding" ducts to ensure clear passage), the rearrangement, transfer, replacement, and removal of existing facilities on a pole or in a conduit system where such work is required solely to accommodate Licensee's facilities and not to meet

BellSouth's business needs or convenience. "Make-Ready work" may require "dig-ups" of existing facilities and may include the repair, enlargement or modification of BellSouth's facilities (including, but not limited to, conduits, ducts, handholes and manholes) or the performance of other work required to make a pole, anchor, conduit or duct usable for the initial placement of Licensee's facilities.

- 1.18 Manhole. The term "manhole" refers to an enclosure, usually below ground level and entered through a hole on the surface covered with a cast iron or concrete manhole cover, which personnel may enter and use for the purpose of installing, operating, and maintaining facilities in a conduit.
- 1.19 Occupancy. The term "occupancy" shall refer to the physical presence of telecommunication facilities in a duct, on a pole, or within a Right-of-way.
- 1.20 Person acting on Licensee's behalf. The terms "person acting on Licensee's behalf," "personnel performing work on Licensee's behalf," and similar terms include both natural persons and firms and ventures of every type, including, but not limited to, corporations, partnerships, limited liability companies, sole proprietorships, and joint ventures. The terms "person acting on Licensee's behalf," "personnel performing work on Licensee's behalf," and similar terms specifically include, but are not limited to, Licensee, its officers, directors, employees, agents, representatives, attorneys, contractors, subcontractors, and other persons or entities performing services at the request of or as directed by Licensee and their respective officers, directors, employees, agents, and representatives.
- 1.21 Person acting on BellSouth's behalf. The terms "person acting on BellSouth's behalf," "personnel performing work on BellSouth's behalf," and similar terms include both natural persons and firms and ventures of every type, including but not limited to corporations, partnerships, limited liability companies, sole proprietorships, and joint ventures. The terms "person acting on BellSouth's behalf," "personnel performing work on BellSouth's behalf," and similar terms specifically include, but are not limited to, BellSouth, its officers, directors, employees, agents, representatives, attorneys, contractors, subcontractors, and other persons or entities performing services at the request or on behalf of BellSouth and their respective officers, directors, employees, agents, and representatives.
- 1.22 Pole. The term "pole" refers to both utility poles and anchors but only to those utility poles and anchors owned or controlled by BellSouth, and does not include utility poles or anchors with respect to which BellSouth has no legal authority to permit attachments by other persons or entities.
- 1.23 Pole Attachment Act. The terms "Pole Attachment Act" and "Pole Attachment Act of 1978" refer to those provisions of the Communications Act of 1934, as amended, now codified as 47 U.S.C. § 224.

- 1.24 Prelicense survey. The term "prelicense survey" refers to all work and activities performed or to be performed to determine whether there is adequate capacity on a pole or in a conduit or conduit system (including manholes and handholes) to accommodate Licensee's facilities and to determine what make-ready work, if any, is required to prepare the pole, conduit or conduit system to accommodate Licensee's facilities.
- 1.25 Right of Way (ROW). The term "right of way" refers to the right to use the land or other property of another party to place poles, conduits, cables, other structures and equipment, or to provide passage to access such structures and equipment. A Right of Way may run under, on, or above public or private property (including air space above public or private property) and may include the right to use discrete space in buildings, building complexes, or other locations.
- 1.26 Sheath. The term "sheath" refers to a single outer covering containing communications wires, fibers, or other communications media.
- 1.27 Spare Capacity. The term "spare capacity" refers to any pole attachment space, conduit, duct or inner-duct not currently assigned or subject to a pending application for attachment/occupancy. Spare capacity does not include an inner-duct (not to exceed one inner-duct per party) reserved by BellSouth, Licensee, or a third party for maintenance, repair, or emergency restoration.
- 1.28 State. When capitalized, the term "State" (as used in terms such as "this State") refers to the State in which the access to BellSouth poles, ducts, conduits or rights-of-way, granted pursuant to this Attachment 8, occurs or attachment is located.
- 1.29 Third Party. The terms "third party" and "third parties" refer to persons and entities other than Licensee and BellSouth. Use of the term "third party" does not signify that any such person or entity is a party to this Attachment 8 or has any contractual rights hereunder.

2. SCOPE OF AGREEMENT

- 2.1 Undertaking of BellSouth. BellSouth shall provide Licensee with equal and nondiscriminatory access to pole space, conduits, ducts, and rights-of-way on terms and conditions equal to those provided by BellSouth to itself, subsidiaries or affiliates, or to any other telecommunications service provider. Further, BellSouth shall not withhold or delay assignment of such facilities to Licensee because of the potential or forecasted needs of itself or other parties.
- 2.2 Attachments and Occupancies Authorized by this Attachment 8. BellSouth shall issue one or more licenses to Licensee authorizing Licensee to attach facilities to BellSouth's owned or controlled poles and to place facilities within BellSouth's owned or controlled conduits, ducts or rights-of-way under the terms and conditions set forth in this Section and the Telecommunications Act of 1996.

- 2.2.1 Unless otherwise provided herein, authority to attach facilities to BellSouth's owned or controlled poles, to place facilities within BellSouth's owned or controlled conduits, ducts or rights-of-way shall be granted only in individual licenses granted under this Attachment 8 and the placement or use of such facilities shall be determined in accordance with such licenses and procedures established in this Attachment 8.
- 2.2.2 Licensee agrees that its attachment of facilities to BellSouth's owned or controlled poles, occupancy of BellSouth's owned or controlled conduits, ducts or rights-of-way shall take place pursuant to the licensing procedures set forth herein, and BellSouth agrees that it shall not unreasonably withhold or delay issuance of such licenses.
- 2.3 Licenses. Subject to the terms and conditions set forth in this Attachment 8, BellSouth shall issue to Licensee one or more licenses authorizing Licensee to place or attach facilities in or to specified poles, conduits, ducts or rights-of-way owned or controlled by BellSouth located within this state on a first come, first served basis. BellSouth may deny a license application if BellSouth determines that the pole, conduit or duct space specifically requested by Licensee is necessary to meet BellSouth's present needs, or is licensed by BellSouth to another licensee, or is otherwise unavailable based on reasonable engineering concerns. BellSouth shall provide written notice to Licensee within forty-five (45) days of the request as per ¶ 1224 of the FCC Docket 96-98 specifying in detail the reasons for denying Licensee's request. BellSouth shall have the right to designate the particular duct(s) to be occupied, the location and manner in which Licensee's facilities will enter and exit BellSouth's conduit system and the specific location and manner of installation for any associated equipment which is permitted by BellSouth to occupy the conduit system.
- 2.4 Access and Use of Rights-of-Way. BellSouth acknowledges that it is required by the Telecommunications Act of 1996 to afford Licensee access to and use of all associated rights-of-way to any sites where BellSouth's owned or controlled poles, manholes, conduits, ducts or other parts of BellSouth's owned or controlled conduit systems are located.
- 2.4.1 BellSouth shall provide Licensee with access to and use of such rights-of-way to the same extent and for the same purposes that BellSouth may access or use such rights-of-way, including but not limited to access for ingress, egress or other access and to construct, utilize, maintain, modify, and remove facilities for which pole attachment, conduit occupancy, or ROW use licenses have been issued, provided that any agreement with a third party under which BellSouth holds such rights expressly or impliedly grants BellSouth the right to provide such rights to others.
- 2.4.2 Where BellSouth notifies Licensee that BellSouth's agreement with a third party does not expressly or impliedly grant BellSouth the ability to provide such access and use rights to others, upon Licensee's request, BellSouth

will use its best efforts to obtain the owner's consent and to otherwise secure such rights for Licensee. Licensee agrees to reimburse BellSouth for the reasonable and demonstrable costs incurred by BellSouth in obtaining such rights for Licensee.

- 2.4.3 In cases where a third party agreement does not grant BellSouth the right to provide access and use rights to others as contemplated in Section 2.4.1 and BellSouth, despite its best efforts, is unable to secure such access and use rights for Licensee in accordance with Section 2.4.2, or, in the case where Licensee elects not to invoke its rights under Section 2.4.1 or Section 2.4.2, Licensee shall be responsible for obtaining such permission to access and use such rights-of-way. BellSouth shall cooperate with Licensee in obtaining such permission and shall not prevent or delay any third party assignment of ROW's to Licensee.
- 2.4.4 Where BellSouth has any ownership or rights-of-way to buildings or building complexes, or within buildings or building complexes, BellSouth shall offer to Licensee through a license or other attachment:
- 2.4.4.1 The right to use any available space owned or controlled by BellSouth in the building or building complex to install Licensee equipment and facilities; and
- 2.4.4.2 Ingress and egress to such space.
- 2.4.5 Except to the extent necessary to meet the requirements of the Telecommunications Act of 1996, neither this Attachment 8 nor any license granted hereunder shall constitute a conveyance or assignment of any of either party's rights to use any public or private rights-of-way, and nothing contained in this Attachment 8 or in any license granted hereunder shall be construed as conferring on one party any right to interfere with the other party's access to any such public or private rights-of-way.
- 2.5 No Effect on BellSouth's Right to Convey Property. Nothing contained in this Attachment 8 or in any license issued hereunder shall in any way affect the right of BellSouth to convey to any other person or entity any interest in real or personal property, including any poles, conduit or ducts to or in which Licensee has attached or placed facilities pursuant to licenses issued under this Attachment 8 provided however that BellSouth shall give Licensee reasonable advance written notice of such intent to convey.
- 2.6 No Effect on BellSouth's Rights to Manage its Own Facilities. This Attachment 8 shall not be construed as limiting or interfering with BellSouth's rights set forth below, except to the extent expressly provided by the provisions of this Attachment 8 or licenses issued hereunder or by the Telecommunications Act of 1996 or other applicable laws, rules or regulations:

- 2.6.1 To locate, relocate, move, replace, modify, maintain, and operate BellSouth's own facilities within BellSouth's conduits, ducts or rights-of way or any of BellSouth's facilities attached to BellSouth's poles at any time and in any reasonable manner which BellSouth deems appropriate to serve its customers, avail itself of new business opportunities, or otherwise meet its business needs; or
- 2.6.2 To enter into new agreements or arrangements with other persons or entities permitting them to attach or place their facilities to or in BellSouth's poles, conduits or ducts; provided, however, that such relocations, moves, replacements, modifications, maintenance and operations or new agreements or arrangements shall not substantially interfere with Licensee's pole attachment, conduit occupancy or ROW use, rights provided by licenses Issued pursuant to this Attachment 8.
- 2.7 No Effect on Licensee's Rights to Manage its Own Facilities. This Attachment 8 shall not be construed as limiting or interfering with Licensee's rights set forth below, except to the extent expressly provided by the provisions of this Attachment 8 or licenses issued hereunder or by the Telecommunications Act of 1996 or other applicable laws, rules or regulations:
- 2.7.1 To locate, relocate, move, replace, modify, maintain, and operate its own facilities within BellSouth's conduits, ducts or rights-of-way or its facilities attached to BellSouth's poles at any time and in any reasonable manner which Licensee deems appropriate to serve its customers, avail itself of new business opportunities, or otherwise meet its business needs; or
- 2.7.2 To enter into new agreements or arrangements with other persons or entities permitting Licensee to attach or place its facilities to or in such other persons' or entities' poles, conduits or ducts, or rights-of-way; provided, however, that such relocations, moves, replacements, modifications, maintenance and operations or new agreements or arrangements shall not conflict with Licensee's obligations under licenses issued pursuant to this Attachment 8.
- 2.8 No Right to Interfere with Facilities of Others. The provisions of this Attachment 8 or any license issued hereunder shall not be construed as authorizing either party to this Attachment 8 to rearrange or interfere in any way with any of the other party's facilities, with the facilities of other persons or entities, or with the use of or access to such facilities by such other party or such other persons or entities, except to the extent expressly provided by the provisions of this Attachment 8 or any license issued hereunder or by the Telecommunications Act of 1996 or other applicable laws, rules or regulations.
- 2.8.1 Licensee acknowledges that the facilities of persons or entities other than BellSouth and Licensee may be attached to or occupy BellSouth's poles, conduits, ducts and rights-of-way.

- 2.8.2 BellSouth shall not attach, or give permission to any third parties to attach facilities to, existing Licensee facilities without Licensee's prior written consent. If BellSouth becomes aware of any such unauthorized attachment to Licensee facilities, BellSouth shall use its best efforts to rectify the situation as soon as practicable.
- 2.8.3 With respect to facilities occupied by Licensee or the subject of an application for attachment by Licensee, BellSouth will give to Licensee 60 days' written notice for conduit extensions or reinforcements, 60 days' written notice for pole line extensions, 60 days' written notice for pole replacements, and 60 days' written notice of BellSouth's intention to construct, reconstruct, expand or place such facilities or of BellSouth's intention not to maintain or use any existing facility and, in the case of an existing facility which BellSouth elects not to maintain or use, BellSouth will grant to Licensee a right to maintain and use such facility. If an emergency or provisions of an applicable joint use agreement require BellSouth to construct, reconstruct, expand or replace poles, conduits or ducts occupied by Licensee or the subject of an application for attachment by Licensee, BellSouth will notify Licensee as soon as reasonably practicable of such proposed construction, reconstruction, expansion or replacement to enable Licensee, if it so desires, to request that a pole, conduit or duct of greater height or capacity be utilized to accommodate an anticipated facility need of Licensee.
- 2.8.4 At Licensee's expense, BellSouth shall remove any retired cable from conduit systems to allow for the efficient use of conduit space within a reasonable period of time.
- 2.9 Assignment of Space. Assignment of space on poles, in conduits or ducts and within ROW's will be made pursuant to licenses granted by BellSouth on an equal basis to BellSouth, Licensee and other telecommunication service providers.

3. REQUIREMENTS AND SPECIFICATIONS

- 3.1 Published Standards Incorporated in this Section by Reference. Licensee agrees that its facilities shall be placed, constructed, maintained, repaired, and removed in accordance with current (as of the date when such work is performed) editions of the following publications, each of which is incorporated by reference as part of this Section :
- 3.1.1 The Blue Book Manual of Construction Procedures, Special Report SR-TAP-001421, published by Bell Communications Research, Inc. ("BellCore"), and sometimes referred to as the "Blue Book";
- 3.1.2 The National Electrical Code (NEC); and
- 3.1.3 The National Electrical Safety Code (NESC).
- 3.2 Changes in Published Standards. Licensee agrees to rearrange its facilities in accordance with changes in the standards published in the

publications specified in Section 3.1 of this Attachment 8 if required by law to do so or upon the mutual agreement of the parties.

- 3.3 Additional Electrical Design Specifications. Licensee agrees that, in addition to specifications and requirements referred to in Section 3.1 above, Licensee's facilities placed in BellSouth's conduit system shall meet all of the following electrical design specifications:
 - 3.3.1 No facility shall be placed in BellSouth's conduit system in violation of FCC regulations.
 - 3.3.2 Licensee's facilities placed in BellSouth's conduit system shall not be designed to use the earth as the sole conductor for any part of Licensee's circuits.
 - 3.3.3 Licensee's facilities carrying more than 50 volts AC (rms) to ground or 135 volts DC to ground shall be enclosed in an effectively grounded sheath or shield.
 - 3.3.4 No coaxial cable of Licensee shall occupy a conduit system containing BellSouth's cable unless such cable of Licensee meets the voltage limitations of Article 820 of the National Electrical Code.
 - 3.3.5 Licensee's coaxial cable may carry continuous DC voltages up to 1800 volts to ground where the conductor current will not exceed one-half amperes and where such cable has two separate grounded metal sheaths or shields and a suitable insulating jacket over the outer sheath or shield. The power supply shall be so designed and maintained that the total current carried over the outer sheath shall not exceed 200 micro amperes under normal conditions. Conditions which would increase the current over this level shall be cleared promptly.
 - 3.3.6 Neither party shall circumvent the other party's corrosion mitigation measures. Each party's new facilities shall be compatible with the other party's facilities so as not to damage any facilities of the other party by corrosion or other chemical reaction.
- 3.4 Additional Physical Design Specifications. Licensee's facilities placed in BellSouth's conduit system must meet all of the following physical design specifications:
 - 3.4.1 Cables bound or wrapped with cloth or having any kind of fibrous coverings or impregnated with an adhesive material shall not be placed in BellSouth's conduit or ducts.
 - 3.4.2 The integrity of BellSouth's conduit system and overall safety of BellSouth's personnel and other personnel working in BellSouth's conduit system requires that "dielectric cable" be required when Licensee's cable facility utilizes an alternative duct or route that is shared in the same trench by any current carrying facility of a power utility.
 - 3.4.3 New construction splices in Licensee's fiber optic and twisted pair cables shall be located in manholes, pull boxes or handholes.

- 3.5 Additional Specifications Applicable to Connections. The following specifications apply to connections of Licensee's conduit to BellSouth's conduit system:
- 3.5.1 Licensee will be permitted to connect its conduit or duct only at the point of a BellSouth manhole. No attachment will be made by entering or breaking into conduit between manholes. All necessary work to install Licensee facilities will be performed by Licensee or its contractor at Licensee's expense. In no event shall Licensee or its contractor "core bore" or make any other modification to BellSouth manhole(s) without the prior written approval of BellSouth, which approval will not be unreasonably delayed or withheld.
- 3.5.2 BellSouth may monitor, at Licensee's expense, the entrance and exit of Licensee's facilities into BellSouth's manholes and the placement of Licensee's facilities in BellSouth's manholes.
- 3.5.3 If Licensee constructs or utilizes a duct connected to BellSouth's manhole, the duct and all connections between that duct and BellSouth's manhole shall be sealed, to the extent practicable, to prevent the entry of gases or liquids into BellSouth's conduit system. If Licensee's duct enters a building, it shall also be sealed where it enters the building and at all other locations necessary to prevent the entry of gases and liquids from the building into BellSouth's conduit system.
- 3.6 Requirements Relating to Personnel, Equipment, Material, and Construction Procedures Generally. Duct clearing, rodding or modifications required to grant Licensee access to BellSouth's conduit systems may be performed by BellSouth at Licensee's expense at charges which represent BellSouth's actual costs. Alternatively (at Licensee's option) such work may be performed by a contractor who demonstrates compliance with BellSouth certification requirements, which certification requirements shall be consistent with FCC rules. The parties acknowledge that Licensee, its contractors, and other persons acting on Licensee's behalf will perform work for Licensee (e.g., splicing Licensee's facilities) within BellSouth's conduit system. Licensee represents and warrants that neither Licensee nor any person acting on Licensee's behalf shall permit any person to climb or work on or in any of BellSouth's poles or to enter BellSouth's manholes or work within BellSouth's conduit system unless such person has the training, skill, and experience required to recognize potentially dangerous conditions relating to pole or the conduit systems and to perform the work safely.
- 3.6.1 Licensee's facilities within BellSouth's conduit system shall be constructed, placed, rearranged, modified, and removed upon receipt of license specified in Section 5.1. However, no such license will be required for the inspection, maintenance, repair or non-physical modifications of Licensee's facilities.

- 3.6.2 "Rodding" or clearing of ducts in BellSouth's conduit system shall be done only when specific authorization for such work has been obtained in advance from BellSouth, which authorization shall not be unreasonably delayed or withheld by BellSouth. The parties agree that such rodding or clearing shall be performed according to existing industry standards and practices. Licensee may contract with BellSouth for performance of such work or (at Licensee's option) with a contractor who demonstrates compliance with BellSouth certification requirements.
- 3.6.3 Personnel performing work on BellSouth's or Licensee's behalf in BellSouth's conduit system shall not climb on, step on, or otherwise disturb the other party's or any third party's cables, air pipes, equipment, or other facilities located in any manhole or other part of BellSouth's conduit system.
- 3.6.4 Personnel performing work on BellSouth's or Licensee's behalf within BellSouth's conduit system (including any manhole) shall, upon completing their work, make reasonable efforts to remove all tools, unused materials, wire clippings, cable sheathing and other materials brought by them to the work site.
- 3.6.5 All of Licensee's facilities shall be firmly secured and supported in accordance with BellCore and industry standards.
- 3.6.6 Licensee's facilities shall be plainly identified with Licensee's name in each manhole with a firmly affixed permanent tag that meets standards set by BellSouth for its own facilities.
- 3.6.7 Manhole pumping and purging required in order to allow Licensee's work operations to proceed shall be performed by a vendor approved by BellSouth in compliance with BellSouth Practice Sec. 620-145-011BT, "Manhole Contaminants, Water, Sediment or Debris Removal and Reporting Procedures," and any amendments, revisions or supplements thereto and in compliance with all regulations and standards established by the United States Environmental Protection Agency and by any applicable state or local environmental regulators.
- 3.6.8 Planks or other types of platforms shall not be installed using cables, pipes or other equipment as a means of support. Platforms shall be supported only by cable racks.
- 3.6.9 Any leak detection liquid or device used by Licensee or personnel performing work on Licensee's facilities within BellSouth's conduit system shall be of a type approved by BellSouth or BellCore.
- 3.6.10 When Licensee or personnel performing work on Licensee's behalf are working within or in the vicinity of any part of BellSouth's poles or conduit system which is located within, under, over, or adjacent to streets, highways, alleys or other traveled rights-of-way, Licensee and all personnel performing work on Licensee's behalf shall follow procedures which Licensee deems appropriate for the protection of persons and

property. Licensee shall be responsible, at all times, for determining and implementing the specific steps required to protect persons and property at the site. Licensee will provide all traffic control and warning devices required to protect pedestrian and vehicular traffic, workers and property from danger. Licensee has sole responsibility for the safety of all personnel performing work on Licensee's behalf, for the safety of bystanders, and for insuring that all operations conform to current OSHA regulations and all other governmental rules, ordinances or statutes. BellSouth reserves the right to suspend Licensee's activities on, in or in the vicinity of BellSouth's poles or conduit system if, in BellSouth's reasonable judgment, any hazardous condition arises due to the activity (including both acts and omissions) of Licensee or any personnel performing work on Licensee's behalf, which suspension shall cease when the condition has been rectified.

- 3.6.11 Except for protective screens, no temporary cover shall be placed by Licensee or personnel performing work on Licensee's behalf over an open manhole unless it is at least four feet above the surface level of the manhole opening.
- 3.6.12 Smoking or the use of any open flame is prohibited in BellSouth's manholes, in any other portion of BellSouth's conduit system, or within 10 feet of any open manhole entrance; provided that this provision will not prohibit the use of spark producing tools such as electric drills, fusion splicers, etc.
- 3.6.13 Artificial lighting, when required, will be provided by Licensee. Only explosion-proof lighting fixtures shall be used.
- 3.6.14 Neither Licensee nor personnel performing work on Licensee's behalf shall allow any combustible gas, vapor, liquid, or material to accumulate in BellSouth's conduit system (including any manhole) during work operations performed within or in the vicinity of BellSouth's conduit system.
- 3.6.15 Licensee will abide by any laws, regulations or ordinances regarding the use of spark producing tools, equipment or devices in BellSouth's manholes, in any other portions of BellSouth's conduit system, or within 10 feet of any open manhole opening. This includes, but is not limited to, such tools as electric drills and hammers, meggers, breakdown sets, induction sets, and the like.
- 3.7 Opening of Manholes. The following requirements apply to the opening of BellSouth's manholes and the authority of BellSouth personnel present when work on Licensee's behalf is being performed within or in the vicinity of BellSouth's conduit system.
 - 3.7.1 BellSouth's manholes shall be opened only as permitted by BellSouth's authorized employees or agents, which permission shall not be unreasonably denied or delayed.

- 3.7.2 Licensee shall notify BellSouth forty-eight (48) hours in advance of any routine work operation requiring entry into any of BellSouth's manholes.
- 3.7.3 Licensee shall be responsible for obtaining any necessary authorization from appropriate authorities to open manholes for conduit work operations therein.
- 3.7.4 BellSouth's authorized employee or agent shall not direct or control the conduct of Licensee's work at the work site. The presence of BellSouth's authorized employee or agent at the work site shall not relieve Licensee or personnel performing work on Licensee's behalf of their responsibility to conduct all work operations within BellSouth's conduit system in a safe and workmanlike manner.
- 3.7.5 Although BellSouth's authorized employee or agent shall not direct or control the conduct of Licensee's work at the work site, BellSouth's employee or agent shall have the authority to suspend Licensee's work operations within BellSouth's conduit system if, in the reasonable discretion of such BellSouth employee or agent, it appears that any hazardous conditions arise or any unsafe practices are being followed by Licensee or personnel performing work on Licensee's behalf.
- 3.7.6 When an emergency situation arises which necessitates Carrier access to a manhole, Carrier should call BellSouth's Access Customer Advocate Center ("ACAC") or the Unbundled Network Element (UNE) Center. BellSouth will then contact the Maintenance Supervisor who will return the Carrier's call and will arrange for access with on-call maintenance field personnel during the emergency condition on an emergency basis. (A list of contact telephone numbers is available to each CLEC for this purpose.)
- 3.8 OSHA Compliance: Notice to BellSouth of Unsafe Conditions. Licensee agrees that:
- 3.8.1 Its facilities shall be constructed, placed, maintained, repaired, and removed in accordance with the Occupational Safety and Health Act (OSHA) and all rules and regulations promulgated thereunder;
- 3.8.2 All persons acting on Licensee's behalf, including but not limited to Licensee's employees, agents, contractors, and subcontractors shall, when working on or within BellSouth's poles or conduit system, comply with OSHA and all rules and regulations thereunder;
- 3.8.3 Licensee shall establish appropriate procedures and controls to assure compliance with all requirements of this section; and
- 3.8.4 Licensee (and any person acting on Licensee's behalf) may report unsafe conditions on, in or in the vicinity of BellSouth's poles or conduit system to BellSouth.
- 3.9 Compliance with Environmental Laws and Regulations. Licensee acknowledges that, from time to time, environmental contaminants may enter BellSouth's conduit system and accumulate in manholes or other

conduit facilities and that certain conduits (transite) are constructed with asbestos-containing materials. If BellSouth has knowledge of the presence of such contaminants in a conduit for which Licensee has applied for or holds a license, BellSouth will promptly notify Licensee of such fact.

Notwithstanding any of BellSouth's notification requirements in this Attachment, Licensee acknowledges that some of BellSouth's conduit is fabricated from asbestos-containing materials. Such conduit is generally marked with a designation of "C Fiber Cement Conduit," "Transite," or "Johns-Manville." Until proven otherwise, Licensee will presume that all conduit not fabricated of plastic, tile, or wood is asbestos-containing and will handle it pursuant to all applicable regulations relating to worker safety and protection of the environment. BellSouth makes no representations to Licensee or personnel performing work on Licensee's behalf that BellSouth's conduit system or any specific portions thereof will be free from environmental contaminants at any particular time. The acknowledgments and representations set forth in the two preceding sentences are not intended to relieve BellSouth of any liability which it would otherwise have under applicable law for the presence of environmental contaminants in its conduit facilities. Licensee agrees to comply with the following provisions relating to compliance with environmental laws and regulations:

- 3.9.1 AT&T may, at its expense, perform such inspections and tests at the site of any pole, duct, conduit, or right-of-way occupied by or assigned to AT&T as AT&T may deem necessary to determine the presence at such sites of environmental contaminants. BellSouth will assist AT&T, at AT&T's request and expense, in the performance of such inspections and tests.
- 3.9.2 Licensee's facilities shall be constructed, placed, maintained, repaired, and removed in accordance with all applicable federal, state, and local environmental statutes, ordinances, rules, regulations, and other laws, including but not limited to the Resource Conservation and Recovery Act (42 U.S.C. §§ 9601, et seq.), the Toxic Substance Control Act (15 U.S.C. §§ 2601-2629), the Clean Water Act (33 U.S.C. §§ 1251, et seq.), and the Safe Drinking Water Act (42 U.S.C. §§ 300f-300j).
- 3.9.3 All persons acting on Licensee's behalf, including but not limited to Licensee's employees, agents, contractors, and subcontractors, shall, when working on, within or in the vicinity of BellSouth's poles or conduit system, comply with all applicable federal, state, and local environmental laws, including but not limited to all environmental statutes, ordinances, rules, and regulations.
- 3.9.4 Licensee shall establish appropriate procedures and controls to assure compliance with all requirements of this section. BellSouth will be afforded a reasonable opportunity to review such procedures and controls

and provide comments that will be reasonably considered in advance of their implementation. Review and comment by BellSouth pursuant to this section will be provided in a timely manner.

- 3.9.5 Licensee and all personnel performing work on Licensee's behalf shall comply with such standards and practices as BellSouth and Licensee may from time to time mutually agree to adopt to comply with environmental laws and regulations including, without limitation, BellSouth Practice Sec. 620-145-011BT, "Manhole Contaminants, Water, Sediment or Debris Removal and Reporting Procedures". Pursuant to this practice, neither Licensee nor BellSouth nor personnel performing work on either party's behalf shall discharge water or any other substance from any BellSouth manhole or other conduit facility onto public or private property, including any storm water drainage system, without first testing such water or substance for contaminants in accordance with mutually agreed standards and practices and determining that such discharge would not violate any environmental law, create any environmental risk or hazard, or damage the property of any person. No such waste material shall be deposited on BellSouth premises for storage or disposal.
- 3.10 Compliance with Other Governmental Requirements. Licensee agrees that its facilities attached to BellSouth's facilities shall be constructed, placed, maintained, and removed in accordance with the ordinances, rules, and regulations of any governing body having jurisdiction of the subject matter. Licensee shall comply with all statutes, ordinances, rules, regulations and other laws requiring the marking and lighting of aerial wires, cables and other structures to ensure that such wires, cables and structures are not a hazard to aeronautical navigation. Licensee shall establish appropriate procedures and controls to assure such compliance by all persons acting on Licensee's behalf, including but not limited to, Licensee's employees, agents, contractors, and subcontractors.
- 3.11 Differences in Standards or Specifications. To the extent that there may be differences in any applicable standards or specifications referred to in this Section 3, the most stringent standard or specification shall apply.
- 3.12 Licensee Solely Responsible for the Condition of Its Facilities. Licensee shall be responsible at all times for the condition of its facilities and its compliance with the requirements, specifications, rules, regulations, ordinances, and laws specified above. In this regard, BellSouth shall have no duty to Licensee to inspect or monitor the condition of Licensee's facilities (including but not limited to splices and other facilities connections) located within BellSouth's conduit and ducts or any attachment of Licensee's facilities to BellSouth's poles, anchors, anchor/guy strands or other pole facilities. BellSouth may, however, conduct such inspections and audits of its poles and conduit system as BellSouth determines reasonable or necessary. Such inspection and audits shall be conducted at BellSouth's expense with the exception of (1) follow-up inspection to confirm remedial action after an observed Licensee

violation of the requirements of this Attachment 8; and (2) inspection of Licensee facilities in compliance with a specific mandate of appropriate governmental authority for which inspections the cost shall be borne by Licensee. Either party may audit the other party's compliance with the terms of this Section. Observed safety hazards or imminent facility failure conditions of another party shall be reported to the affected party where such party can be readily identified.

- 3.13 Efficient use of Conduit. BellSouth will install inner-ducts to increase duct space in existing conduit as facilities permit. The full complement of inner-ducts will be installed which can be accommodated under sound engineering principles. The number of inner-ducts which can reasonably be installed will be determined by BellSouth.

4. ADDITIONAL LEGAL REQUIREMENTS

- 4.1 Third Party Property Owners. Licenses granted under this Section authorize Licensee to place facilities in, or attach facilities to, poles, conduits and ducts owned or controlled by BellSouth but do not affect the rights of landowners to control terms and conditions of access to their property.
- 4.1.1 Licensee agrees that neither Licensee nor any persons acting on Licensee's behalf, including but not limited to Licensee's employees, agents, contractors, and subcontractors, shall engage in any conduct which damages public or private property in the vicinity of BellSouth's poles or conduit system, interferes in any way with the use or enjoyment of public or private property except as expressly permitted by the owner of such property, or creates a hazard or nuisance on such property (including, but not limited to, a hazard or nuisance resulting from any abandonment or failure to remove Licensee's facilities or any construction debris from the property, failure to erect warning signs or barricades as may be necessary to give notice to others of unsafe conditions on the premises while work performed on Licensee's behalf is in progress, or failure to restore the property to a safe condition after such work has been completed).
- 4.2 Required Permits, Certificates and Licenses. Licensee shall be responsible for obtaining any building permits or certificates from governmental authorities necessary to construct, operate, maintain and remove its facilities on public or private property.
- 4.2.1 Licensee shall not attach or place its facilities to or in BellSouth's poles, conduit or duct located on any property for which it or BellSouth has not first obtained all required authorizations.
- 4.2.2 BellSouth shall have the right to request evidence that all appropriate authorizations have been obtained. However, such request shall not delay BellSouth's prelicense survey work.

4.3 Lawful Purposes. All facilities placed by Licensee in BellSouth's conduit and ducts or on BellSouth's poles, anchors or anchor/guy strands must serve a lawful purpose and the uses made of Licensee's facilities must comply with all applicable federal, state, and local laws and with all federal, state, and local regulatory rules, regulations, and requirements. In this regard, Licensee shall not utilize any facilities occupying or attached to BellSouth's conduits, ducts or poles for the purpose of providing any services which it is not authorized by law to provide or for the purpose of enabling any other person or entity to provide any such services.

5. **FACILITIES AND LICENSES**

5.1 Licenses Required. Before placing any facilities in BellSouth's conduits or ducts or attaching any facilities to BellSouth's poles, anchors or anchor/guy strands, Licensee must first apply for and receive a written license from BellSouth. BellSouth shall not unreasonably deny or delay issuance of any license.

5.2 Provision of Records and Information to Licensee. In order to obtain information regarding facilities, Licensee shall make a written request to BellSouth, identifying with reasonable specificity the geographic area for which facilities are required, the types and quantities of the required facilities and the required in-service date. In response to such request, BellSouth shall provide Licensee with information regarding the types, quantity and location (which may be provided by provision of route maps) and availability of BellSouth poles, conduit and right-of-way located within the geographic area specified by Licensee. Provision of information under the terms of this section shall include the right of Licensee employees or agents to inspect and copy engineering records or drawings which pertain to those facilities within the geographic area identified in Licensee's request. Such inspection and copying shall be done at a time and place mutually agreed upon by the parties. See Exhibit B, attached hereto and incorporated herein by this reference, for records location centers.

5.3 No Warranty of Record Information. Licensee acknowledges that records and information provided by BellSouth pursuant to paragraph 5.2 may not reflect field conditions and that physical inspection is necessary to verify presence and condition of outside plant facilities and right of way. In providing such records and information, BellSouth assumes no liability to Licensee or any third party for errors/omissions contained therein.

5.4 Determination of Availability. BellSouth shall provide pole, conduit and right-of-way availability information in response to a request from Licensee which identifies with reasonable specificity the facilities for which such information is desired. Licensee may elect to be present at any field based survey of facilities identified pursuant to this paragraph and BellSouth shall provide Licensee at least forty-eight (48) hours notice prior to initiating such field survey. Licensee employees or agents shall be

permitted to enter BellSouth manholes and inspect such structures to confirm usability and/or evaluate condition of the structure(s) with at least forty-eight (48) hours notice to BellSouth, with a BellSouth representative present and at Licensee's expense.

6. MAKE-READY WORK

6.1 Work Performed by BellSouth. If performed by BellSouth, make-ready work to accommodate Licensee's facilities shall be included in the normal work load schedule of BellSouth with construction responsibilities in the geographic areas where the relevant poles or conduit systems are located and shall not be subjugated to BellSouth work, nor entitled to priority, advancement, or preference over other work to be performed by BellSouth in the ordinary course of BellSouth's business.

6.1.1 If Licensee desires make-ready work to be performed on an expedited basis and BellSouth agrees to perform the work on such a basis, BellSouth shall recalculate the estimated make-ready charges. If Licensee accepts BellSouth's offer, Licensee shall pay such additional charges.

6.2 All charges for make-ready work performed by BellSouth are payable in advance, with the amount of any such advance payment to be due within sixty (60) days after receipt of an invoice from BellSouth.

6.3 Work Performed by Certified Contractor. In lieu of obtaining performance of make-ready work by BellSouth, Licensee at its option may arrange for the performance of such work by a contractor certified by BellSouth to work on or in its facilities. Certification shall be granted based upon reasonable and customary criteria employed by BellSouth in the selection of its own contract labor. Notwithstanding any other provisions of this Section, Licensee may not employ a contractor to accomplish make-ready work if BellSouth is likewise precluded from contractor selection under the terms of an applicable joint use agreement or collective bargaining agreement. In accordance with Section 3.6.7, all manhole pumping and purging shall be performed by a vendor approved by BellSouth.

6.4 Completion of Make-Ready Work. BellSouth will issue a license to Licensee at the time all make-ready work necessary to Licensee's attachment or occupancy has been completed.

7. APPLICATION FORM AND FEES

7.1 Application Process. To apply for a license under this Section, Licensee shall submit to BellSouth two signed copies of an Application and Conduit Occupancy License form or an Application and Pole Attachment License form. BellSouth will process license applications in the order in which they are received; provided, however, that when Licensee has multiple applications on file with BellSouth, Licensee may designate its desired priority of completion of prelicense surveys and make-ready work with respect to all such applications.

- 7.1.1 Each application for a license under this Section shall specify the proposed route of Licensee's facilities and identify the conduits and ducts or poles and pole facilities along the proposed route in which Licensee desires to place or attach its facilities, and describe the physical size, weight and jacket material of the cable which Licensee desires to place in each conduit or duct or the number and type of cables, apparatus enclosures and other facilities which Licensee desires to attach to each pole.
- 7.1.2 Each application for a license under this Section shall be accompanied by a proposed (or estimated) construction schedule containing the information specified below in Section 10.1 of this Attachment 8, and an indication of whether Licensee will, at its option, perform its own make-ready work.
- 7.2 Multiple Cables, Multiple Services, Lashing or Placing Additional Cables, and Replacement of Facilities. Licensee may include multiple cables in a single license application and multiple services (e.g., CATV and non-CATV services) may be provided by Licensee in the same cable sheath. Licensee's lashing additional cable to existing facilities and placing additional cables in conduits or ducts already occupied by Licensee's facilities shall be permitted, and no additional fees will be applied; provided, however, that if Licensee desires to lash additional cable to existing facilities of a third party Licensee shall provide BellSouth with reasonable notice, and shall obtain written permission from the owner of the existing facilities. If BellSouth determines that the requested lashing would violate safety or engineering requirements, BellSouth shall provide written notice to Licensee within a reasonable time specifying in detail BellSouth's findings. If Licensee desires to place additional cables in conduits or ducts which are already occupied, or to replace existing facilities with new facilities substantially different from those described in licenses in effect, Licensee must apply for and acquire a new license specifically describing the physical size, weight and jacket material of the cable to be placed in BellSouth's conduits and ducts or the physical size, weight, and jacket type of cables and the size and weight of apparatus enclosures and other facilities to be attached to BellSouth poles.
- 7.3 Each party hereby designates the employees named below as their single point of contact for any and all purposes of this Section, including, but not limited to, processing licenses and applications and providing records and information. Each party may at any time designate a new point of contact by giving written notice of such change.

	Notices	Billing Address
<i>To Licensee as follows:</i>		
Contact	Bill C. Peacock	

Title	District Manager	
Company	AT&T	
Address	Promenade I, Room 12254	
Address	1200 Peachtree St., N.E.	
City, State, and Zip Code	Atlanta, GA 30309	
Telephone	(404) 810-6710	
Facsimile	(404) 810-8605	

and to Licensor as follows:

Contact	Arthur Wiliams
Title	Manager
Company	BellSouth Telecommunications, Inc.
Address	North W3D2
Address	3535 Colonnade Parkway
City, State, and Zip Code	Birmingham, AL 35243
Telephone	(205) 977-5068
Facsimile	(205) 977-7997

8. PROCESSING OF APPLICATIONS (INCLUDING PRELICENSE SURVEYS AND FIELD INSPECTIONS)

8.1 Licensee's Priorities. When Licensee has multiple applications on file with BellSouth, Licensee shall designate its desired priority of completion of prelicense surveys and make-ready work with respect to all such applications.

8.2 Prelicense Survey. After Licensee has submitted its written application for a license, a prelicense survey (including a field inspection) will be performed by either party, in the company of a representative of the other party as mutually agreed, to determine whether BellSouth's poles, anchors and anchor/guy strands, or conduit system, in their present condition, can accommodate Licensee's facilities, without substantially interfering with the ability of BellSouth or any other authorized person or entity to use or access the pole, anchor or anchor/guy strand or any portion of BellSouth's conduit system or facilities attached to BellSouth's pole or placed within or connected to BellSouth's conduit system. If Licensee gives its prior written consent in writing, the determination of duct availability may include the "rodding" of ducts at Licensee's expense.

8.2.1 The purpose of the prelicense survey is to determine whether Licensee's proposed attachments to BellSouth's poles or occupancy of BellSouth's

conduit and ducts will substantially interfere with use of BellSouth's facilities by BellSouth and others with facilities occupying, connected or attached to BellSouth's pole or conduit system; and to provide information to Licensee for its determination of whether the pole, anchor, anchor/guy strand, conduit, duct, or right-of-way is suitable for its use.

- 8.2.2 Based on information provided by BellSouth and the survey, Licensee shall determine whether BellSouth's pole, anchor, anchor/guy strand, conduit and duct facilities are suitable to meet Licensee's needs.
- 8.2.3 BellSouth may not unreasonably refuse to continue to process an application based on BellSouth's determination that Licensee's proposed use of BellSouth's facilities will not be in compliance with applicable requirements, specifications, rules, regulations, ordinances, and laws. Licensee shall be responsible for making its own, independent determination that its use of such facilities will be in compliance with such requirements, specifications, rules, regulations, ordinances and laws. Licensee acknowledges that BellSouth is not explicitly or implicitly warranting to Licensee that Licensee's proposed use of BellSouth's facilities will be in compliance with applicable requirements, specifications, rules, regulations, ordinances, and laws.
- 8.3 Administrative Processing. The administrative processing portion of the prelicense survey (which includes without limitation processing the application, preparing make-ready work orders, notifying joint users and other persons and entities of work requirements and schedules, coordinating the relocation/rearrangement of BellSouth and/or other licensed facilities) will be performed by BellSouth at Licensee's expense. Anything to the contrary herein notwithstanding, BellSouth shall bear no responsibility for the relocation, rearrangement or removal of facilities used for the transmission or distribution of electric power.

9. ISSUANCE OF LICENSES

- 9.1 Obligation to Issue Licenses. BellSouth shall issue a license to Licensee pursuant to this Section 9. BellSouth and Licensee acknowledge that each application for a license shall be evaluated on an individual basis. Nothing contained in this section shall be construed as abridging any independent pole attachment rights or conduit or duct access rights which Licensee may have under the provisions of any applicable federal or state laws or regulations governing access to BellSouth's poles, conduits and ducts, to the extent the same are not inconsistent with the Telecommunications Act of 1996. Each license issued hereunder shall be for an indefinite term, subject to Licensee's compliance with the provisions applicable to such license and further subject to Licensee's right to terminate such license at any time for any reason upon at least thirty (30) days' prior written notice.
- 9.2 Multiple Applications. Licensee acknowledges that multiple parties including BellSouth may seek to place their facilities in BellSouth's conduit

and ducts at or about the same time, that the make-ready work required to prepare BellSouth's facilities to accommodate multiple applicants may differ from the make-ready work required to accommodate a single applicant, that issues relating to the proper apportionment of costs arise in multi-applicant situations that do not arise in single-applicant situations, and that cooperation and negotiations between all applicants and BellSouth may be necessary to resolve disputes involving multiple applications for permission to place facilities in/on the same pole, conduit, duct, or right-of-way.

- 9.2.1 All applications will be processed on a first-come, first-served basis.
- 9.3 Agreement to Pay for All Make-Ready Work Completed. Licensee's submission of written authorization for make-ready work shall also constitute Licensee's agreement to pay additional cost-based charges, if any, for completed make-ready work.
- 9.4 Payments to Others for Expenses Incurred in Transferring or Arranging Their Facilities. Licensee shall make arrangements with the owners of other facilities located in or connected to BellSouth's conduit system or attached to BellSouth's poles, anchors or anchor/guy strands regarding reimbursement for any expenses incurred by them in transferring or rearranging their facilities to accommodate the placement or attachment of Licensee's facilities in or to BellSouth's structures.
- 9.5 Make-Ready Work on an Expedited Basis. If Licensee is willing to authorize BellSouth to perform make-ready work on an expedited basis, and if BellSouth agrees to perform the work on such a basis, BellSouth shall recalculate the estimated make-ready charges. If Licensee accepts BellSouth's offer, Licensee shall pay such additional charges, if any.
- 9.6 License. When Licensee's application for a pole attachment or conduit occupancy license is approved, and all required make-ready work completed, BellSouth will execute and return a signed authorization to Licensee, as appropriate, authorizing Licensee to attach or place the specified facilities on BellSouth's poles or in BellSouth's conduit or ducts.
- 9.6.1 Each license issued under this Section shall authorize Licensee to attach to BellSouth's poles or place or maintain in BellSouth's conduit or ducts only those facilities specifically described in the license, and no others.
- 9.6.2 Except as expressly stated to the contrary in individual licenses issued hereunder, each license issued pursuant to this Section shall incorporate all terms and conditions of this Section whether or not such terms or conditions are expressly incorporated by reference on the face of the license itself.
- 10. CONSTRUCTION OF LICENSEE'S FACILITIES**
- 10.1 Construction Schedule. Licensee shall submit with Licensee's license application a proposed or estimated construction schedule. Promptly after the issuance of a license permitting Licensee to attach facilities to

BellSouth's poles or place facilities in BellSouth's conduit or ducts, Licensee shall provide BellSouth with an updated construction schedule and shall thereafter keep BellSouth informed of significant anticipated changes in the construction schedule. Construction schedules required by this Section shall include, at a minimum, the following information:

- 10.1.1 The name, title, business address, and business telephone number of the manager responsible for construction of the facilities;
 - 10.1.2 The names of each contractor and subcontractor which will be involved in the construction activities;
 - 10.1.3 The estimated dates when construction will begin and end; and
 - 10.1.4 The approximate dates when Licensee or persons acting on Licensee's behalf will be performing construction work in connection with the placement of Licensee's facilities in BellSouth's conduit or ducts.
- 10.2 Additional Pre-construction Procedures for Facilities Placed in Conduit System. The following procedures shall apply before Licensee places facilities in BellSouth's conduit system:
- 10.2.1 Licensee shall give written notice of the type of facilities which are to be placed; and
 - 10.2.2 BellSouth shall designate the particular duct or ducts or inner ducts (if available) to be occupied by Licensee's facilities, the location and manner in which Licensee's facilities will enter and exit BellSouth's conduit system, and the specific location and manner of installation of any associated equipment which is permitted by BellSouth to occupy the conduit system. Licensee may not occupy a duct other than the specified duct without the express written consent of BellSouth. BellSouth shall provide to Licensee space in manholes for racking and storage of up to fifty (50) feet of cable, provided space is available.
- 10.3 BellSouth Not Responsible for Constructing or Placing Facilities. BellSouth shall have no obligation to construct any facilities for Licensee or to attach Licensee's facilities to, or place Licensee's facilities in, BellSouth's poles or conduit system, except as may be necessary to facilitate the interconnection of unbundled network elements or except to the extent expressly provided in this Section, any license issued hereunder, or by the Telecommunications Act of 1996 or any other applicable law.
- 10.4 Licensee Responsible for Constructing, Attaching and Placing Facilities. Except where otherwise mutually agreed by Licensee and BellSouth, Licensee shall be responsible for constructing its own facilities and attaching those facilities to, or placing them in BellSouth's poles, conduit or ducts at Licensee's sole cost and expense. Licensee shall be solely responsible for paying all persons and entities who provide materials, labor, access to real or personal property, or other goods or services in connection with the construction and placement of Licensee's facilities

and for directing the activities of all persons acting on Licensee's behalf while they are physically present on BellSouth's pole, in any part of BellSouth's conduit system or in the vicinity of BellSouth's poles or conduit system.

- 10.5 Compliance with Applicable Standards, Health and Safety Requirements, and Other Legal Requirements. Licensee shall construct its facilities in accordance with the provisions of this Section and all licenses issued hereunder.
- 10.5.1 Licensee shall construct, attach and place its facilities in compliance with all Requirements and Specifications set forth above in this Attachment 8.
- 10.5.2 Licensee shall satisfy all Legal Requirements set forth above in this Attachment 8.
- 10.5.3 Licensee shall not permit any person acting on Licensee's behalf to perform any work on BellSouth's poles or within BellSouth's conduit system without first verifying, to the extent practicable, on each date when such work is to be performed, that the condition of the pole or conduit system is suitable for the work to be performed. If Licensee or any person working on Licensee's behalf determines that the condition of the pole or conduit system is not suitable for the work to be performed, Licensee shall notify BellSouth of the condition of the pole or conduit system in question and shall not proceed with construction activities until Licensee is satisfied that the work can be safely performed.
- 10.6 Construction Notices. If requested to do so, Licensee shall provide BellSouth with information to reasonably assure BellSouth that construction has been performed in accordance with all applicable standards and requirements.
- 10.7 Points for Attachment. BellSouth shall specify, using the same selection criteria it uses for its own operating company, the point of attachment of each pole or anchor to be occupied by Licensee's facilities. When the facilities of more than one applicant are involved, BellSouth will attempt, to the extent practicable, to designate the same relative position on each pole or anchor for each applicant's facilities.
- 10.8 Manhole and Conduit Break-Outs. Licensee shall be permitted to add conduit ports to BellSouth manholes when existing conduits do not provide the pathway connectivity needed by Licensee; provided the structural integrity of the manhole is maintained, and sound engineering judgment is employed.
- 11. USE AND ROUTINE MAINTENANCE OF LICENSEE'S FACILITIES**
- 11.1 Use of Licensee's Facilities. Each license granted under this Section authorizes Licensee to have access to Licensee's facilities on or in BellSouth's poles, conduits and ducts as needed for the purpose of serving Licensee's customers, including, but not limited to, powering electronics, monitoring facilities, or transporting signaling.

- 11.2 Routine Maintenance of Licensee's Facilities. Each license granted under this Section authorizes Licensee to engage in routine maintenance of Licensee's facilities located on or in BellSouth's poles, conduits, ducts and ROW pursuant to such license. Licensee shall give reasonable notice to the affected public authority or private landowner as appropriate before commencing the construction or installation of its attachments or making any material alterations thereto. Licensee shall give reasonable notice to BellSouth before performing any work, whether or not of a routine nature, in BellSouth's conduit system.
- 11.3 Licensee Responsible for Maintenance of Licensee's Facilities. Licensee shall maintain its facilities in accordance with the provisions of this Section (including but not limited to all requirements set forth above in this Attachment 8) and all licenses issued hereunder. Licensee shall be solely responsible for paying all persons and entities who provide materials, labor, access to real or personal property, or other goods or services in connection with the maintenance of Licensee's facilities and for directing the activities of all persons acting on Licensee's behalf while they are physically present on BellSouth's poles, within BellSouth's conduit system or in the immediate vicinity of such poles or conduit system.
- 11.4 BellSouth Not Responsible for Maintaining Licensee's Facilities. BellSouth shall have no obligation to maintain any facilities which Licensee has attached or connected to, or placed in, BellSouth's poles, conduits, ducts or any portion of BellSouth's conduit system, except to the extent expressly provided by the provisions of this Section or any license issued hereunder, or by the Telecommunications Act of 1996 or other applicable laws, rules or regulations.
- 11.5 Information Concerning the Maintenance of Licensee's Facilities. Promptly after the issuance of a license permitting Licensee to attach facilities to, or place facilities in BellSouth's poles, conduits or ducts, Licensee shall provide BellSouth with the name, title, business address, and business telephone number of the manager responsible for routine maintenance of Licensee's facilities, and shall thereafter notify BellSouth of changes to such information. The manager responsible for routine maintenance of Licensee's facilities shall, on BellSouth's request, identify any contractor, subcontractor, or other person performing maintenance activities on Licensee's behalf at a specified site and shall, on BellSouth's request, provide such additional documentation relating to the maintenance of Licensee's facilities as reasonably necessary to demonstrate that Licensee and all persons acting on Licensee's behalf are complying with the requirements of this Section and licenses issued hereunder.
- 11.6 Identification of Personnel Authorized to Have Access to Licensee's Facilities. All personnel authorized to have access to Licensee's facilities shall, while working on BellSouth's poles, in its conduit system or ducts or in the vicinity of such poles, ducts or conduit systems, carry with them

suitable identification and shall, upon the request of any BellSouth employee, produce such identification.

12. MODIFICATION AND REPLACEMENT OF LICENSEE'S FACILITIES

12.1 Notification of Planned Modification or Replacement of Facilities.

Licensee shall, when practicable, notify BellSouth in writing at least 60 days before adding to, relocating, replacing or otherwise modifying its facilities attached to a BellSouth pole, anchor or anchor/guy strand or located in any BellSouth conduit or duct. The notice shall contain sufficient information to enable BellSouth to determine whether the proposed addition, relocation, replacement, or modification is permitted under Licensee's present license or requires a new or amended license.

12.2 New or Amended License Required. A new or amended license will be required if the proposed addition, relocation, replacement, or modification:

12.2.1 Requires that Licensee use additional space on BellSouth's poles or in its conduits or ducts (including but not limited to any additional ducts, inner ducts, or substantial space in any handhole or manhole) on either a temporary or permanent basis; or

12.2.2 Results in the size or location of Licensee's facilities on BellSouth's poles or in its conduit or ducts being appreciably different from those described and authorized in Licensee's present license (e.g., different duct or size increase causing a need to re-calculate storm loadings, guying, or pole class).

13. REARRANGEMENT OF FACILITIES AT THE REQUEST OF ANOTHER

13.1 Make-Ready Work at the Request of Licensee. If, prior to the issuance of a license, Licensee determines that any pole, anchor, anchor/guy strand, conduit or duct is inadequate to accommodate Licensee's proposed pole attachment or conduit occupancy or that it will be necessary or desirable for BellSouth or any other person or entity to rearrange existing facilities or structures to accommodate Licensee, Licensee shall promptly advise BellSouth of the make-ready work it believes necessary to enable the accommodation of Licensee's facilities.

13.1.1 BellSouth shall determine, in the exercise of sound engineering judgment, whether or what make-ready work is necessary or possible. In determining whether make-ready work is necessary or what make-ready work is necessary, BellSouth shall endeavor to minimize its costs to Licensee. If it is determined that such make-ready work is required, BellSouth shall provide Licensee with the estimated costs for make-ready work and a Make Ready Due Date.

13.1.2 Licensee shall be solely responsible for negotiating with persons or entities other than BellSouth for the rearrangement of such persons' or entities' facilities or structures and, except where such rearrangement is for the benefit of BellSouth and/or other licensees as well as Licensee,

shall be solely responsible for paying all charges attributable to the rearrangement of such facilities; provided, however, that if facilities rearrangements require new licenses from BellSouth, BellSouth shall issue such licenses in conjunction with the issuance of the applied-for license to Licensee.

- 13.2 Rearrangement of Licensee's Facilities at BellSouth's Request. Licensee acknowledges that, from time to time, it may be necessary or desirable for BellSouth to change out poles, relocate, reconstruct, or modify portions of its conduit system or rearrange facilities contained therein or connected thereto and that such changes may be necessitated by BellSouth's business needs or authorized application of another entity seeking access to BellSouth's poles or conduit systems. Licensee agrees that Licensee will, upon BellSouth's request, and at BellSouth's expense, but at no cost to Licensee, participate with BellSouth (and other licensees) in the relocation, reconstruction, or modification of BellSouth's conduit system or facilities rearrangement. Licensee acknowledges that, from time to time, it may be necessary or desirable for BellSouth to change out poles, relocate, reconstruct, or modify portions of its conduit system or rearrange facilities contained therein or connected thereto as a result of an order by a municipality or other governmental authority. Licensee shall, upon BellSouth's request, participate with BellSouth (and other licensees) in the relocation, reconstruction, or modification of BellSouth's conduit system or facilities rearrangement and pay its proportionate share of any costs of such relocation, reconstruction, or modification that are not reimbursed by such municipality or governmental authority.
- 13.2.1 Licensee shall make all rearrangements of its facilities within such period of time as is jointly deemed reasonable by the parties based on the amount of rearrangements necessary and a desire to minimize chances for service interruption or facility-based service denial to a Licensee customer.
- 13.2.2 If Licensee fails to make the required rearrangements within the time prescribed or within such extended periods of time as may be granted by BellSouth in writing, BellSouth may perform such rearrangements with written notice to Licensee, and Licensee shall reimburse BellSouth for actual costs and expenses incurred by BellSouth in connection with the rearrangement of Licensee's facilities; provided, however, that nothing contained in this Section or any license issued hereunder shall be construed as requiring Licensee to bear any expenses which, under the Telecommunications Act of 1996 or other applicable federal or state laws or regulations, are to be allocated to persons or entities other than Licensee; and provided further, however, that Licensee shall have no responsibility for rearrangement costs and expenses relating to rearrangements performed for the purpose of meeting BellSouth's business needs.

14. EMERGENCY REPAIRS AND POLE REPLACEMENTS

14.1 Licensee Responsible for Emergency Repairs to its Own Facilities. In general, Licensee shall be responsible for making emergency repairs to its own facilities and for formulating appropriate plans and practices which will enable it to make such emergency repairs. BellSouth shall be under no obligation to perform any repair or service restoration work of any kind with respect to Licensee's facilities.

15. INSPECTION BY BELL SOUTH OF LICENSEE'S FACILITIES

15.1 BellSouth's Right to Make Periodic or Spot Inspections. BellSouth shall have the right to make periodic or spot inspections at any time of any part of Licensee's facilities attached to BellSouth's poles, anchors or anchor/guy strands or occupying any BellSouth conduit or duct for the limited purpose of determining whether Licensee's facilities are in compliance with the terms of this Section and licenses hereunder; provided that such inspections must be non-invasive (e.g., no splice cases may be opened).

15.1.1 BellSouth will give Licensee advance written notice of such inspections, and Licensee shall have the right to have a representative attend such inspections, except in those instances where safety considerations justify the need for such inspection without the delay of waiting until written notice has been forwarded to Licensee.

15.1.2 Such inspections shall be conducted at BellSouth's expense; provided, however, that Licensee shall bear the cost of inspections as delineated in Section 3.12.

15.2 No Duty to Licensee. Neither the act of inspection by BellSouth of Licensee's facilities nor any failure to inspect such facilities shall operate to impose on BellSouth any liability of any kind whatsoever or to relieve Licensee of any responsibility, obligations or liability under this Section or otherwise existing.

16. NOTICE OF NONCOMPLIANCE

16.1 Notice of Noncompliance. If, at any time, BellSouth determines that Licensee's facilities or any part thereof have not been placed or maintained or are not being used in accordance with the requirements of this Attachment 8, BellSouth may send written notice to Licensee specifying the alleged noncompliance. Licensee agrees to acknowledge receipt of the notice as soon as practicable. If Licensee does not dispute BellSouth's assertion that such facilities are not in compliance, Licensee agrees to provide BellSouth with a schedule for bringing such facilities into compliance, to bring the facilities into compliance within a reasonable time, and to notify BellSouth in writing when the facilities have been brought into compliance.

16.2 Disputes over Alleged Noncompliance. If Licensee disputes BellSouth's assertion that Licensee's facilities are not in compliance, Licensee shall

notify BellSouth in writing of the basis for Licensee's assertion that its facilities are in compliance.

- 16.3 Failure to Bring Facilities into Compliance. If Licensee has not brought the facilities into compliance within a reasonable time or provided BellSouth with proof sufficient to persuade BellSouth that BellSouth erred in asserting that the facilities were not in compliance, and if BellSouth determines in good faith that the alleged noncompliance causes or is likely to cause material damage to BellSouth's facilities or those of other users, BellSouth may, at its option and Licensee's expense, take such non-service affecting steps as may be required to bring Licensee's facilities into compliance, including but not limited to correcting any conditions which do not meet the specifications of this Attachment 8.
- 16.4 Correction of Conditions by BellSouth. If BellSouth elects to bring Licensee's facilities into compliance, the provisions of this Section shall apply.
- 16.4.1 BellSouth will, whenever practicable, notify Licensee in writing before performing such work. The written notice shall describe the nature of the work to be performed and BellSouth's schedule for performing the work.
- 16.4.2 If Licensee's facilities have become detached or partially detached from supporting racks or wall supports located within a BellSouth manhole, BellSouth may, at Licensee's expense, reattach them but shall not be obligated to do so. If BellSouth does not reattach Licensee's facilities, BellSouth shall endeavor to arrange with Licensee for the reattachment of any facilities affected.
- 16.4.3 BellSouth shall, as soon as practicable after performing the work, advise Licensee in writing of the work performed or action taken. Upon receiving such notice, Licensee shall inspect the facilities and take such steps as Licensee may deem necessary to insure that the facilities meet Licensee's performance requirements.
- 16.5 Licensee to Bear Expenses. Licensee shall bear all expenses arising out of or in connection with any work performed to bring Licensee's facilities into compliance with this Section; provided, however that nothing contained in this Section or any license issued hereunder shall be construed as requiring Licensee to bear any expenses which, under applicable federal or state laws or regulations, must be borne by persons or entities other than Licensee.
- 17. UNAUTHORIZED OCCUPANCY OR UTILIZATION OF BELL SOUTH'S FACILITIES**
- 17.1 Licensing or Removal of Unauthorized Attachments. If any of Licensee's attachments shall be found attached to pole(s) or occupying conduit systems for which no license is outstanding, BellSouth, without prejudice to its other rights or remedies under this Attachment 8, including termination of licenses, may impose a charge and require Licensee to

submit in writing, within thirty (30) days after receipt of written notification from BellSouth of the unauthorized attachment or conduit occupancy, a pole attachment or conduit occupancy license application. If such application is not received by BellSouth within the specified time period, Licensee may be required at BellSouth's option to remove its unauthorized attachment or occupancy within sixty (60) days of the final date for submitting the required application, or BellSouth may at BellSouth's option remove Licensee's facilities without liability, and the expense of such removal shall be borne by Licensee. Charges for any such unauthorized occupancy shall be equal to the applicable license fees and charges which would have been payable from and after the date such facilities were first placed on BellSouth's poles or in BellSouth's conduit system, if Licensee provides reasonable documentation of such placement. If Licensee is unable to provide such reasonable documentation, then Licensee will pay two years worth of the applicable charges.

- 17.1.1 Nothing contained in the Attachment 8 or any license issued hereunder shall be construed as requiring Licensee to bear any expenses which, under applicable federal or state laws or regulations, must be borne by persons or entities other than Licensee.
- 17.2 Prompt Payment of Applicable Fees and Charges. Fees and charges for pole attachments and conduit system occupancies, as specified herein and as modified from time to time, shall be due and payable immediately whether or not Licensee is permitted to continue the pole attachment or conduit occupancy. See Exhibit A, attached hereto and incorporated herein by this reference, for applicable annual rental fees.
- 17.3 No Implied Waiver or Ratification of Unauthorized Use. No act or failure to act by BellSouth with regard to said unlicensed use shall be deemed as a ratification of the unlicensed use; and if any license should be subsequently issued, said license shall not operate retroactively or constitute a waiver by BellSouth of any of its rights or privileges under this Attachment 8 or otherwise; provided, however, that Licensee shall be subject to all liabilities, obligations and responsibilities of this Attachment 8 in regard to said unauthorized use from its inception.

18. REMOVAL OF LICENSEE'S FACILITIES

- 18.1 Pole Attachments. Licensee, at its expense, will remove its attachments from any of BellSouth's poles within thirty (30) days after termination of the license covering such attachments. If Licensee fails to remove its attachments within such thirty (30) day period, BellSouth shall have the right to remove such attachments at Licensee's expense and without any liability on the part of BellSouth for damage or injury to Licensee's attachments unless caused by the negligence or intentional misconduct of BellSouth.

- 18.2 Conduit Occupancy. Licensee, at its expense, will remove its communications facilities from a conduit system within sixty (60) days after:
- 18.2.1 Termination of the license covering such conduit occupancy; or
- 18.2.2 The date Licensee replaces its existing facilities in one duct with substitute facilities in another duct.
- 18.2.3 If Licensee fails to remove its facilities within the specified period, BellSouth shall have the right to remove such facilities at Licensee's expense and without any liability on the part of BellSouth for damage or injury to such facilities unless caused by the negligence or intentional misconduct of BellSouth.
- 18.3 Continuing Responsibility for Fees and Charges. Licensee shall remain liable for and pay to BellSouth all fees and charges pursuant to provisions of this Attachment 8 until all of Licensee's facilities are physically removed from BellSouth's poles or conduit system.

19. FEES, CHARGES, AND BILLING

- 19.1 License Charges. License charges commence on the first day of the calendar month following the date a license is issued. Such charges cease as of the final day of the calendar month preceding the month in which the attachment or occupancy is physically removed or the utilization is discontinued. A one-month minimum charge is applicable to all licenses.
- 19.2 Notice of Rate and Computation of Charges. On or about November 1 of each year, BellSouth will notify Licensee by certified mail, return receipt requested, of the rental rate and pole transfer rate to be applied in the subsequent calendar year. The letter of notification shall be incorporated in, and governed by, the terms and conditions of this Attachment 8. Attachment and occupancy rates shall be applied to the number of pole(s) and duct feet of conduit for which licenses have been issued before December 1 of each calendar year. Charges for attachment(s) and occupancy which commenced during the preceding twelve (12) month period will be prorated accordingly.

20. ADVANCE PAYMENT AND IMPUTATION

- 20.1 Attachment and Occupancy Fees. Fees for pole attachment and conduit occupancy shall be based on the facilities for which licenses have been issued as of the date of billing by BellSouth, shall be computed as set forth herein.
- 20.1.1 Charges associated with newly licensed attachments or occupancies and other attachments or occupancies of less than the entire annual billing period shall be prorated.
- 20.1.2 Charges shall be prorated retroactively in the event of the removal of Licensee's facilities.

20.1.3 The amount of any advance payment required shall be due within sixty (60) days after receipt of an invoice from BellSouth.

20.2 Imputation. BellSouth shall impute to its costs of providing telecommunications services (and charge any affiliate, subsidiary, or associate company engaged in the provision of such services) an equal amount to the charges set forth in this Section for all of the conduits, ducts, and poles it occupies and uses.

21. **ASSURANCE OF PAYMENT**

21.1 Necessity and Level of Security. In the event Licensee fails to demonstrate credit worthiness, Licensee may be required to furnish a bond, letter of credit or other evidence of financial security having a minimum face amount of \$10,000.00 per state or \$50,000.00 per region. Such bond, letter of credit or other security shall be in a form satisfactory to BellSouth and may be increased from time to time as reasonably required by BellSouth to guarantee the performance of all obligations of Licensee hereunder. The amount of the bond, letter of credit or other security shall not operate as a limitation upon the obligations of Licensee hereunder.

22. **INSURANCE**

22.1 Licensee shall obtain and maintain insurance (or provide written evidence of being self-insured), including endorsements insuring the contractual liability and indemnification provisions of this Attachment 8, issued by an insurance carrier reasonably satisfactory to Licensor to protect the Licensor, other authorized Licensees, and Joint User(s) from and against all claims demands, causes of action, judgments, costs, including reasonable attorneys' fees, expenses and liabilities of every kind and nature which may arise or result, directly or indirectly from or by reason of such loss, injury or damage as covered in this Attachment 8.

22.2 Licensee shall maintain the following amounts of insurance in compliance with Section 22.1 above:

22.2.1 Commercial General Liability Insurance with limits of not less than \$1,000,000 per occurrence and \$1,000,000 annual aggregate.

22.2.2 Umbrella or Excess Liability Insurance with limits of not less than \$10,000,000 per occurrence and in the aggregate.

22.3 Licensee shall submit to Licensor certificates by each company insuring Licensee with respect to any insurance required hereunder, such certificate(s) to specify the coverage provided and that such company will not cancel or change any such policy of insurance issued to Licensee except after sixty (60) days written notice to Licensor.

22.4 Licensee shall also carry such insurance as will protect it from all claims under any Worker's Compensation Law in effect that may be applicable to it as a result of work performed pursuant to this Attachment 8.

22.5 All insurance required in accordance with Sections 22.2 and 22.3 preceding must be effective before Licensor will authorize attachment to a Pole and/or Anchor, or occupancy of a Conduit System and shall remain in force until such Licensee's facilities have been removed from all such Pole(s), Anchor(s), Conduit System, or Right of Way. In the event that the Licensee shall fail to maintain the required insurance coverage, Licensor may pay any premium thereon falling due, and the Licensee shall forthwith reimburse the Licensor for any such premium paid.

22.6 Licensee may self-insure any or all of the insurance coverages required in this Attachment 8.

23. AUTHORIZATION NOT EXCLUSIVE

23.1 Nothing herein contained shall be construed as a grant of any exclusive authorization, right or privilege to Licensee. BellSouth shall have the right to grant, renew and extend rights and privileges to others not parties to this Attachment 8, by contract or otherwise, to use any Pole, Anchor, or Conduit System covered by this Attachment 8 and Licensee's rights hereunder.

24. ASSIGNMENT OF RIGHTS

24.1 Any assignment by either party of any right, obligation, or duty, in whole or part, or of any interest, without the written consent of the other party (such consent not to be unreasonably withheld) shall be void. Notwithstanding the above, either party, upon written notice to the other party, may assign this agreement and any of its rights and privileges under this Attachment 8, in whole or in part, to: (1) its parent, partners or their respective subsidiaries, affiliates or successors; (2) any entity which controls, is under the control of, or is under common control with the assigning party; or 3) any entity that purchases all or substantially all of the assets of the assigning party by way of merger, acquisition, or consolidation.

24.2 In the event such consent or consents are granted by BellSouth, then the provisions of this Attachment 8 shall apply to and bind the successors and assigns of the Licensee. Form NT-13 shall be used for this purpose.

25. FAILURE TO ENFORCE

25.1 Failure of BellSouth to enforce or insist upon compliance with any of the terms or conditions of this Attachment 8 or to give notice or declare this Attachment 8 or any authorization granted hereunder terminated shall not constitute a general waiver or relinquishment of any term or condition of this Attachment 8, but the same shall be and remain at all times in full force and effect.

26. DISPUTE RESOLUTION

When a dispute arises under this Attachment, either Party may avail itself of the complaint procedures set forth in 47 C.F.R. Ch. I, Subpart J--Pole Attachment Complaint Procedures, ¶¶ 1.1401-1.1416.

26.1 Termination of this Attachment 8 or any licenses issued hereunder shall not affect Licensee's liabilities and obligations incurred hereunder prior to the effective date of such termination.

27. SUPERSEDURE OF PREVIOUS AGREEMENT(S)

27.1 This Attachment 8 supersedes all previous agreements, whether written or oral, between BellSouth and Licensee for attachment and maintenance of Licensee's Communications Facilities on Pole(s), Anchor(s), and in Conduit Systems within the geographical area covered by this Attachment 8; and there are no other provisions, terms or conditions to this Attachment 8 except as expressed herein. All currently effective licenses heretofore granted pursuant to such previous agreements shall be subject to the terms and conditions of this Attachment 8.

2000 FCC Formula Supported Fees
for attachments and/or occupancy effective 1/1/2000
(Re-calculated annually)

Licensee shall pay to Licensor the following fees:

State	Poles (ea. / yr.)	Anchors (ea. / yr.)	Conduit	
				(\$ / ft. / yr.)
Alabama	\$ 3.35	\$ 4.89		\$ 0.23
Kentucky ①				0.70
2-user	9.45	\$ 12.90		
3-user	5.35	8.60		
Louisiana	6.90 ②			0.44
Mississippi	4.30			2.50 ③
Tennessee ④	4.57			0.30
Florida	3.74			0.36
		Miami River crossing		17.13
Georgia ⑤	4.69			0.35
North Carolina	3.55			0.35
South Carolina	2.93			0.30

- ① All rates in Kentucky are by tariff
- ② March 12, 1999 order placed a freeze on existing, approved rate until December 31, 2002. Therefore, \$6.90 rate remains in effect.
- ③ Tariff rate in Mississippi
- ④ Tennessee rates are negotiated with CATV Association; conduit rates were established in 1998 and fixed indefinitely
- ⑤ FCC formula calculated rates; differs from Docket 7061-U

Conduit rates have been developed using the one-half (1/2) duct convention for 2000. This rate will apply to each passageway (innerduct).

- i) For the purpose of determining the Duct feet chargeable, the Duct considered occupied shall be measured from the center to center of adjacent Manhole(s), or from the center of a Manhole to the end of a Duct not terminated in a Manhole.
- ii) The above rates are not applicable for crossings of any navigable waterway. Rates for navigable waterway crossings will be calculated on an individual case basis.

Pole Attachment Transfer Rate

Per pole (throughout BellSouth region)

\$41.00

Records Maintenance Centers

For **Alabama** plant and right of way records:

Records Maintenance Center
S04
1876 Data Drive
Birmingham, AL 35244

For **Kentucky** plant and right of way records:

Records Maintenance Center
Room 2-SW
601 W. Chestnut Street
Louisville, KY 40203

For **Louisiana** plant and right of way records:

Records Maintenance Center
2nd Floor North
6767 Bundy Road
New Orleans, LA 70140

For **Mississippi** plant and right of way records:

Records Maintenance Center
5723 Hwy. 18 S
Jackson, MS 39209

For **Tennessee** plant and right of way records:

Records Maintenance Center
Room 9 B 15
333 Commerce Street
Nashville, TN 37201

For **Georgia, Florida, North Carolina, and South Carolina:**

Plant Records

Records Maintenance Center
5228 Central Avenue
Charlotte, NC 28212

Right of Way Records

Regional Landbase Admin. Center
Attn.: Right of Way Records
16 GG 1 BST
301 W. Bay Street
Jacksonville, FL 32201

Attachment 9
Service Quality Measurements

TABLE OF CONTENTS

1.	Scope	3
2.	Reporting	3
3.	Modifications to Measurements	3
4.	Dispute Resolution.....	4

Service Quality Measurements

1. Scope

- 1.1 This Attachment includes all Service Quality Measurements applicable to this Agreement.
- 1.2 If the Commission issues an order mandating certain service quality measurements or performance measurements and associated remedies, such order will supercede this Attachment on the effective date of the order. Such order will only be effective in the state in which the ordered was issued.

2. Reporting

- 2.1 In providing services pursuant to this Agreement, BellSouth will report its performance to AT&T in accordance with BellSouth's Service Quality Measurements, which are contained in Exhibit A, located on the BellSouth Internet web site.

3. Modifications to Measurements

3.1 Service Quality Measurements

- 3.1.1 BellSouth will update the Service Quality Measurements contained in Exhibit A, located on the BellSouth Internet web site, each calendar quarter. BellSouth will not delete any Service Quality Measurement without prior written consent of AT&T. AT&T may provide input to BellSouth regarding any suggested additions, deletions or other modifications to the Service Quality Measurements. BellSouth will provide notice of all changes to the Service Quality Measurements via BellSouth's internet website.
- 3.1.2 Notwithstanding the foregoing, BellSouth may, from time to time, be ordered by a regulatory or judicial body to modify or amend the Service Quality Measurements. BellSouth will make all such changes to the Service Quality Measurements pursuant to Section 16.3 of the General Terms and Conditions of this Agreement, incorporated herein by this reference. Nothing herein shall preclude either party from participating in any proceeding involving BellSouth's Service Quality Measurements or from advocating that those Measurements be modified from those contained herein.
- 3.1.3 Notwithstanding any other provision of this Agreement, in the event a dispute arises regarding the modification or amendment of the Service Quality Measurements, the parties will refer the dispute to the Commission.

4. Dispute Resolution

- 4.1 Notwithstanding any other provision of this Agreement, any dispute regarding BellSouth's performance or obligations pursuant to this Attachment shall be resolved by the Commission.

Attachment 10

Bona Fide Request/New Business Request Process

Bona Fide Request/New Business Request Process

- 1.0 When applicable. Bona Fide Request/New Business Requests (“BFR/NBR”) are to be used when AT&T requests any Services and Elements not already provided in this Agreement or the process needed to provide the Services and Elements, which process is not provided in this Agreement, (collectively for purposes of this Attachment 10, “the Services”). AT&T may also utilize this process to make a request not already provided in this Agreement where said request does not constitute a request under the Telecommunications Act of 1996. This Attachment 10 does not apply to Section 9 of the General Terms and Conditions of this Agreement, incorporated herein by this reference.
- 1.1 Details required. A BFR/NBR shall be submitted in writing by AT&T and shall specifically identify: (i) the date requested for the Services; (ii) the Services requested; (iii) the associated technical requirements; (iv) space requirements; and (v) other specifications necessary to clearly define the request. If applicable, such a request also shall include AT&T's designation of the request as being an obligation of BellSouth pursuant to the Telecommunications Act of 1996.
- 1.2 AT&T cancellation. AT&T may cancel a BFR/NBR in writing at any time. BellSouth will then cease analysis of the request. If AT&T cancels a BFR/NBR after BellSouth has received AT&T's written "notice to proceed" as described in Section 1.6 of this Attachment 10, AT&T agrees to pay BellSouth the reasonable, demonstrable, and actual costs directly related to complying with AT&T's BFR/NBR up to the date of cancellation.
- 1.3 BellSouth acknowledgment. Within two (2) business days of receipt of a BFR/NBR, BellSouth shall acknowledge in writing its receipt and identify its single point of contact responsible for responding to the request and shall request any additional information needed to process the request. Notwithstanding the foregoing, BellSouth may reasonably request additional information from AT&T at any time during the processing of the BFR/NBR.
- 1.4 Preliminary analysis delivery. Unless otherwise agreed by both parties in writing, within thirty-five (35) calendar days of its receipt of a BFR/NBR, BellSouth shall either provide to AT&T a preliminary analysis of the BFR/NBR or notify AT&T that it needs more time to provide AT&T with its preliminary analysis, at which time AT&T and BellSouth will then determine a mutually agreeable date for delivery of the preliminary analysis.

- 1.5 Preliminary analysis details. The preliminary analysis will state whether BellSouth can meet AT&T's requirements and shall include BellSouth's proposed price plus or minus 25 percent ("the Preliminary Analysis Range") and the date the request can be met. If BellSouth cannot provide the Services by the requested date, it shall provide an alternative proposed date together with a detailed explanation as to why BellSouth is not able to meet AT&T's requested date. The preliminary analysis also will include a detailed breakdown of the costs supporting the proposed price, including the development costs, as defined in Section 1.7 below, necessary to complete AT&T's BFR/NBR. BellSouth also shall indicate in the preliminary analysis its agreement or disagreement with AT&T's designation of the request as an obligation under the Telecommunications Act of 1996. If BellSouth does not agree with AT&T's designation, it may use the dispute resolution process set forth in Section 18 of the General Terms and Conditions of this Agreement, incorporated herein by this reference. In no event, however, shall any dispute delay BellSouth's processing of the request.
- 1.6 Notice to proceed. After providing the preliminary analysis to AT&T, BellSouth shall proceed with AT&T's BFR/NBR upon receipt of AT&T's written "notice to proceed." This "notice to proceed" shall not be construed by BellSouth as a waiver of AT&T's right to invoke dispute resolution process set forth in Section 16 of the General Terms and Conditions of this Agreement, incorporated herein by this reference, as to any issue, including BellSouth's proposed price, the reasonable, demonstrable, and actual costs incurred in the event of AT&T's cancellation of a BFR/NBR, or the amount of development costs paid. All payments are subject to adjustment according to the outcome of the dispute resolution process set forth in Section 16 of the General Terms and Conditions of this Agreement, incorporated herein by this reference. In no event shall any dispute delay BellSouth proceeding with completing the BFR/NBR.
- 1.7 Development costs. Subject to the provision of Section 1.6 above, after receipt and review of BellSouth's preliminary analysis, if AT&T decides to proceed, AT&T agrees to pay the fixed amount identified in the preliminary analysis for the initial work required to develop the project plan, create the design parameters, and establish all activities and resources required to complete the BFR/NBR. These costs will be referred to as "development" costs. The development costs identified in the preliminary analysis are fixed. AT&T will begin processing the payment of development costs at the time it issues the written "notice to proceed" with payment due to BellSouth within 15 days of the issuance of the notice to proceed.

- 1.8 Interim payment in the event of price dispute. In the event of a dispute over payments made by AT&T or requested by BellSouth, including development costs and any interim progress payment, upon BellSouth's written request, AT&T agrees to negotiate an interim lump sum progress payment to compensate BellSouth for its reasonable, demonstrable and actual costs incurred in processing AT&T's BFR/NBR. The interim lump sum progress payment shall be calculated by determining the average between BellSouth's proposed price and AT&T's estimate of the price for processing its BFR/NBR. AT&T agrees to pay 50% of this amount as the interim lump sum progress payment. If AT&T's proposed price is less than 50% of BellSouth's proposed price, the average shall be calculated by assuming that AT&T's price is exactly 50% of BellSouth's proposed price.
- 1.9 Firm quote delivery. As soon as possible, but in no event later than sixty-five (65) calendar days after receipt of the request, BellSouth shall provide AT&T with a firm BFR/NBR response that will include, at a minimum, the firm availability date, the installation intervals, a binding price quote, which shall not exceed the Preliminary Analysis Range, and a final detailed breakdown of all costs supporting the final price.
- 1.10 Acceptance or rejection of firm quote. Within thirty (30) calendar days after receipt of the firm BFR/NBR response from BellSouth, AT&T will notify BellSouth in writing of its acceptance or rejection of BellSouth's proposal. If BellSouth receives no response to the firm quote from AT&T within the thirty day time frame, BellSouth shall issue a written request for confirmation that AT&T does not wish to proceed with the BFR/NBR. If BellSouth receives no response from AT&T within five (5) calendar days of its written request for confirmation, BellSouth may consider the BFR/NBR canceled. BellSouth may recover any costs incurred to the extent permitted under the provision of Section 1.2 of this Attachment 10.
- 1.11 Pricing Principles. Unless AT&T agrees otherwise, all proposed prices shall be derived in accordance with the Act and any applicable Commission rules and regulations. Payments for Services purchased under a BFR/NBR will be made as specified in this Attachment 10, unless otherwise agreed to by AT&T.
- 1.12 Amendment. Upon AT&T's acceptance of the firm quote by BellSouth, the parties shall amend the Agreement to incorporate the Services contemplated by the BFR/NBR. The amendment shall include all pertinent rates, terms and conditions and shall be filed with the

appropriate regulatory commission pursuant to the requirements of the Act.

ATTACHMENT 11

ACRONYMS

ACRONYM	DEFINITION
AAA	American Arbitration Association
AABS	Automated Alternate Billing System (AABS)
ACAC	Access Customer Advocate Center
ADA	Americans with Disabilities Act
ADSL	Asynchronous Digital Subscriber Line
ADUF	Access Daily Usage File
AIN	Advanced Intelligent Network
ALEC	Alternative Local Exchange Carrier
ALI/DMS	Automatic Location Identification/Data Management Systems
AMA	Automatic Message Accounting
AMI	Alternate Marked Inversion
ANI	Automatic Number Identification
ANSI	American National Standards Institute
ASPR	AT&T Security Policy and Requirements
ASR	Access Services Request
ASWC	AT&T Serving Wire Center
ATIS	Alliance for Telecommunications Industry Solutions
ATM	Asynchronous Transfer Mode
BACR	Billing Account Cross Reference
BAN	Billing Account Number
BAPCO	BellSouth Advertising and Publishing Company
BAR	Billing Account Reference
BFR/NBR	Bona Fide Request/New Business Request
BLV	Busy Line Verification
BLV/BLI	Busy Line Verification/Busy Line Interrupt
BLV/BLVI	Busy Line Verification/Busy Line Verification Interrupt
BLV/ELI	Busy Line Verification/Emergency Line Interrupt
BNS	Billed Number Screening
BOC	Bell Operating Company
BOS	Billing Output Specifications
BRI	Basic Rate ISDN
BSWC	BellSouth Serving Wire Center
CABS	Carrier Access Billing Systems
CAMA	Centralized Automatic Message Accounting
CARE	Customer Account Record Exchange
CATS	Calling Card and Third Number Settlement System
CATV	Cable Television
CBOS	CABS Billing Output Specifications
CCC	Clear Channel Capability
CCITT	Consultative Committee on International Telegraph & Telephone

CCL	Common Carrier Line
CCS	Common Channel Signaling
CCSAS	Common Channel Signaling Access Service
CCSNIS	Common Channel Signaling Network Interface Specification
CERCLA	Comprehensive Environmental Response Compensation and Liability Act
CI	Customer Interface
CIC	Carrier Identification Code
CF/B	Call Forward on Busy
CF-B/DA	Call Forward on Busy/Don't Answer
CF/DA	Call Forward Don't Answer
CFR	Code of Federal Regulations
CPN	Calling Party Number
CLASS	Custom Local Area Signaling Service
CLEC	Competitive Local Exchange Carrier
CLLI	Common Language Location Identifier
CLLIC	Common Language Location Identifier Code
CLUB	Customized Large User Bill
CMDS	Centralized Message Distribution System
CMRS	Commercial Mobile Radio Service
CNAM	Calling Name Delivery Database Service
CO	Central Office
CPE	Customer Premises Equipment
CPR	CPR Institute for Dispute Resolution
CRIS	Customer Record Information System
CSA	Contract Service Arrangement
CSIQ	Customer Service Information Query
CSOTS	Customer Service Order Trouble System
CSR	Customer Service Record
CT	Common Transport
CY	Current Year
DA	Directory Assistance
DADAS	Direct Access to Directory Assistance Service
DADS	Directory Assistance Database Service
DB	Database
DCC	Data Communications Channel
DCS	Digital Cross-Connect System
DDD	Desired Due Date
DID	Direct Inward Dialing
DLC	Digital Loop Carrier
DLR	Design Layout Record
DMOQs	Direct Measures of Quality
DN	Directory Numbers

DN-RI	Directory Number - Route Index
DS-0	Digital Signal Level Zero
DS-1	Digital Signal Level One
DS-3	Digital Signal Level Three
DRAM	Digital Recorded Announcement Machine
DSLAM	Digital Subscriber Line Access Multiplexer
DSN	Data Set Name
DSX	Digital Cross Connect
DT	Dedicated Transport
DTMF	Dual-Tone Multi Frequency
DTN	Destination Telephone Number
E&M	Ear & Mouth Signaling
EAMF	Equal Access Multi-Frequency
EBAS	Enhanced Billing and Access Service
EBCDIC	Extended Binary-Coded Decimal Interchange Code
ECTA	Exchange Carrier Trouble Analysis
EDI	Electronic Data Interface
EDI-PC	Electronic Data Interface – Personal Computer
EFT	Electronic Funds Transfer
EI	Electronic Interface
EI	Emergency Interrupt
ELI	Emergency Line Interrupt
EMI	Exchange Message Interface
EMR	Exchange Message Record
EO	End Office
EODUF	Enhanced Optional Daily Usage File
E/O	Electrical to Optical
EPA	Environmental Protection Agency
ESF	Extended Super Frame
ESIT	Exchange Service Interconnection Traffic
ESP	Enhanced Service Provider
ETTR	Estimated Time to Repair
FB	Flat Rate Business Line
FCC	Federal Communications Commission
FDI	Feeder Distribution Interface
FGA	Feature Group A
FGB	Feature Group B
FGD	Feature Group D
FL	Foreign Listing
FOC	Firm Order Confirmation
FR	Flat Rate Residential Line
FRS	Functional Requirements Specification
FSPOI	Facilities Signaling Point of Interconnection
GSST	General Subscriber Services Tariff

GTT	Global Title Translation
HDSL	High-bit-rate Digital Subscriber Line
HFC	Hybrid Fiber Coax
HVAC	Heating/Ventilation/Air Conditioning
IAM	Initial Address Message
IBC	Initial Billing Company
ID	Remote Identifiers
IDLC	Integrated Digital Loop Carrier
IEEE	Institute of Electrical and Electronic Engineers
IITP	Internetwork Interoperability Test Plan
ILEC	Incumbent Local Exchange Carrier
INC	Industry Numbering Committee
INP	Interim Number Portability
IOF	Interoffice Facility
IP	Internet Protocol
IPP	Independent Payphone Provider
ISDN	Integrated Services Digital Network
ISDNUP	Integrated Services Digital Network User Part
ISNI	Intermediate Signaling Network Identifier
ISP	Internet Service Provider
ISUP	Integrated Services User Part
ITU	International Telecommunications Union
IVS	Interactive Voice Subsystem
IVMS	Interswitch Voice Messaging Service
IXC	Interexchange Carrier
JIA	Joint Implementation Agreement
JIP	Jurisdiction Information Parameter
LATA	Local Access Transport Area
LCC	Line Class Code
LCSC	Local Carrier Service Center
LEC	Local Exchange Carrier
LENS	Local Exchange Navigation System
LERG	Local Exchange Routing Guide
LGX	Lightguide Cross-Connect
LIDB	Line Information Database
LNP	Local Number Portability
LPIC	Local (IntraLata) Primary Exchange Carrier
LRN	Local Routing Number
LRN-LNP	Local Routing Number-Local Number Portability
LRN-PNP	Local Routing Number-Permanent Number Portability
LSR	Local Service Request
LSSGR	LATA Switching Systems Generic Requirements
MDF	Main Distribution Frame
MDU	Multiple Dwelling Unit

MECAB	Multiple Exchange Carrier Access Billing
MECOD	Multiple Exchange Carrier Ordering and Design
MF	Multi-Frequency
MLT	Mechanized Loop Tests
MPB	Meet-Point Billing
MPOE	Minimum Point of Entry
MRVT	MTP Routing Verification Test
MSAG	Master Street Address Guide
MTA	Multiple Tandem Access
MTP	Message Transfer Port
MTTR	Mean Time to Repair
MWI	Message Waiting Indicator
NANC	North American Numbering Council
NAV	Network Applications Vehicle
NC	Network Cable
NEBS	Network Equipment Building System
NEC	National Electrical Code
NECA	National Exchange Carrier Association
NESC	National Electrical Safety Code
NGDLC	Next Generation Digital Loop Carrier
NICS	Non-Intercompany Settlement System
NID	Network Interface Device
NIU	Network Interface Unit
NPA	Numbering Plan Area
NPAC	Number Portability Administration Center
NRC	Non-recurring Charge
NTW	Network Terminating Wire
NXX	Three-Digit Central Office Code (N=2-9, X=0-9)
OAM	Operation and Maintenance
OAM&P	Operations Administration Maintenance & Provisioning
OBF	Ordering and Billing Forum
OC	Order Coordination
OC-TS	Order Coordination Time Specific
OC-N	Optical Circuit – (Number)
OCN	Operating Company Number
OSHA	Occupational Safety and Health Act
ODUF	Optional Daily Usage File
OLI	Originating Line Information
OMAP	Operations, Maintenance & Administration Part
ORT	Operational Readiness Test
OS	Operator Services
OSS	Operational Support Systems
OTS	Operator Transfer Service
PBX	Private Branch Exchange

PCBs	Polychlorinated biphenyls
PDH	Plesiochronous Digital Hierarchy
PIC	Primary Interexchange Carrier
PIN	Personal Identification Number
PIU	Percent Interstate Usage
PLU	Percent Local Usage
PNP	Permanent Number Portability
POI	Point of Interface
POI	Points of Interconnection
PON	Purchase Order Number
POP	Point of Presence
POT	Point of Termination
POTS	Plain Old Telephone Service
PSAP	Public Safety Answering Point
PSTN	Public Switched Telecommunications Network
PUC	Public Utilities Commission
RACF	Remote Access Call Forwarding
RAO	Revenue Accounting Office
RCF	Remote Call Forwarding
RCRA	Resource Conservation and Recovery Act
RI	Route Index
RIC	Residual Interconnection Charges
RI-PH	Route Index - Portability Hub
ROW	Right of Way
RSAG	Regional Street Address Guide
RSM	Remote Switch Module
RT	Remote Terminal
SAG	Street Address Guide
SBC	Subsequent Billing Company
SCCP	Signaling Connection Control Point
SCE	Service Creation Environment
SCE/SMS	Service Creation Environment and Service Management System
SCP	Service Control Points
SDH	Synchronous Digital Hierarchy
SEC LOC	Secondary Location
SECAB	Small Exchange Carrier Access Billing
SIC	Standard Industrial Code
SL1	Service Level One
SL2	Service Level Two
SMDI	Simplified Message Desk Interface
SMDI-E	Simplified Message Desk Interface - Enhanced
SMS	Service Management System
SONET	Synchronous Optical Network

SP	Signaling Point
SPID	Service Profile Identifier
SPNP	Service Provider Number Portability
SPNP-RCF	Service Provider Number Portability-Remote Call Forwarding
SPNP-LERG	Service Provider Number Portability-Local Exchange Routing Guide
SPNP-DID	Service Provider Number Portability-Direct Inward Dialing
SPNP-RI	Service Provider Number Portability-Route Indexing
SPOC	Single Point of Contact
SPOI	Signaling Point of Interconnection
SQM	Service Quality Measurement
SRVT	SCCP Routing Verification Test
SS7	Signaling System 7
SSP	Switching Service Point
STP	Signaling Transfer Point
STPS	Signaling Transfer Point Switch
STS	Synchronous Transport Signal
SWA	Interexchange Carrier Switched Access
TAFI	Trouble Analysis Facilitation Interface
TAG	Telecommunications Access Gateway
TC	Transaction Code
TCAP	Transaction Capabilities Application Port
TELRIC	Total Element Long Run Incremental Cost
TGSR	Trunk Group Service Request
TIA/EIA	Telecommunications Industries Association/Electronic Industries Association
TLN	Telephone Line Number
TNS	Transit Network Selection
TOPS	Traffic Operator Position System
TR	Technical Requirements
TS	Tandem Switching
TSGR	Transport System Generic Requirements
UCL	Unbundled Copper Loop
UDL	Unbundled Digital Loop
UDLC	Universal Digital Loop Carrier
UNE	Unbundled Network Element
USL	Unbundled Subloop
USLC	Unbundled Subloop Concentration System
USOC	Universal Service Order Code
UVL	Unbundled Voice-grade Loop
V&H	Vertical and Horizontal
WTN	Working Telephone Number

xDSL	Digital Subscriber Line
------	-------------------------

ATTACHMENT 12

NETWORK SECURITY

NETWORK SECURITY

1. **Network Security – Protection of Service and Property**
- 1.1 BellSouth agrees to take reasonable and prudent steps to ensure adequate protection of AT&T property located with BellSouth Premises including, but not limited to:
 - 1.1.1 Controlling all approved system and modem access through security servers. Access to, or connection with, a network element shall be established through a secure network or security gateway and/or firewall. Dial-up access to modems connected to network entry points must be protected by individual authentication of the user, e.g., via Network Access passwords, smart cards, tokens;
 - 1.1.2 A security software package will be used, or at a minimum, perform manual checks that monitor user and machine integrity and confidentiality, such as password assignment and aging, directory and permission configuration, and system accounting data; and
 - 1.1.3 Maintain accurate and complete records detailing the individual data connections and systems to which they have granted the other party access or interface privileges. These records will include, but are not limited to, login identification, user request records, system configuration, time limits of user access or system interfaces.

ATTACHMENT 13

BAPCO AGREEMENT

AGREEMENT

In consideration of the mutual promises contained herein, BellSouth Advertising & Publishing Corporation, a Georgia corporation ("BAPCO") and AT&T Corp., a New York corporation ("CARRIER") agree as follows:

1. **RECITALS.** BAPCO is the publisher of alphabetical and classified directories for certain communities in the southeastern region of the U.S (the "Directories"). CARRIER provides, or intends to provide, local exchange telephone service in communities in which BAPCO publishes Directories. BAPCO and CARRIER hereby establish the terms by which BAPCO will include listings of CARRIER subscribers in such Directories and by which BAPCO will provide such Directories to CARRIER subscribers. BAPCO agrees that it will treat CARRIER as well as all other local exchange carriers consistent with BAPCO's internal standards.
2. **CARRIER OBLIGATIONS.** CARRIER agrees as follows:
 - (a) CARRIER shall provide to BAPCO, or its designee, at CARRIER's expense and at no charge, listing information concerning its subscribers (designating any who do not desire published listings), consisting of customer name, address, telephone number and all other information reasonably requested by BAPCO as set forth on Exhibit A for use by BAPCO or its affiliates or agents in publishing Directories of whatever type and format and for other derivative purposes such as electronic directories or publishing. Such subscriber listing information shall be provided in the format and on the schedule set forth in said Exhibit, or as otherwise mutually agreed between the parties from time to time.
 - (b) CARRIER shall also provide directory delivery information to BAPCO as set forth in Exhibit A for all subscribers.
 - (c) CARRIER shall advise BAPCO promptly of any directory-related inquiries, requests or complaints which it may receive from CARRIER subscribers and shall provide reasonable cooperation to BAPCO in response to or resolution of the same.
 - (d) CARRIER shall respond promptly regarding corrections or queries raised by BAPCO to process listing changes requested by subscribers.
3. **BAPCO OBLIGATIONS.** Provided that CARRIER: (1) is certified by the applicable state's public service commission for provision of local exchange service; (2) has established appropriate resale or interconnection arrangements with BellSouth Telecommunications, Inc. ("BellSouth") or is pursuing the same in good faith; (3) warrants in writing its good faith intent to commence offering local exchange service in the relevant Directory coverage area (except as otherwise provided in Exhibit C hereto)

for no less than five months of the effective Directory service period; (4) warrants in writing that it shall notify BAPCO when CARRIER actually commences provision of local exchange service in the Directory service area; (5) warrants in writing that all CARRIER telephone numbers listed will be answered by service representatives during normal business hours during the Directory service period; BAPCO agrees as follows:

(a) BAPCO shall include at no charge to CARRIER or CARRIER's subscribers one standard listing for each CARRIER subscriber per hunting group in BAPCO's appropriate local alphabetical Directory as published periodically by BAPCO unless nonlisted or nonpublished status is designated by subscribers. Such listings shall be interfiled with the listings of other local exchange telephone company subscribers and otherwise published in the manner of such other listings in accordance with and subject to BAPCO's generally applicable publishing policies and standards without designation or differentiation as to the subscriber's exchange carrier.

(b) BAPCO shall publish additional listings, foreign listings and all other alphabetical Directory listings offered by BellSouth, for CARRIER subscribers upon their request, consistent with BAPCO's generally applicable policies in BAPCO's alphabetical Directories. BAPCO shall publish all listings for all carriers' subscribers in an identical manner and upon the same terms, conditions and applicable policies.

(c) BAPCO will distribute its regularly published alphabetical and classified Directories to local CARRIER subscribers in accordance with BAPCO's prevailing practices, including delivery following Directory publication and upon establishment of new CARRIER service, if a current Directory for that geographic area has not previously been provided. Such deliveries may include separate advertising materials accompanying the Directories.

(d) Except as otherwise provided herein, BAPCO will include for CARRIER, in the same manner as that included for all other carriers, information relating to establishment of service, repair and billing in the generic customer guide pages of its alphabetical Directories in accordance with BAPCO's prevailing standards for the same. BAPCO shall not include any carrier logos in CARRIER's generic customer guide pages; provided, however, that CARRIER shall have the option of including its own logo in such pages in the event that BAPCO allows any other carrier to include its logo in the generic customer guide pages. CARRIER will provide information requested by BAPCO for such purpose on a timely basis.

(e) BAPCO shall make available at no charge to CARRIER or its subscribers one listing for CARRIER business customers per hunting group in one appropriate heading in BAPCO's appropriate local classified directory as published periodically by BAPCO. Such listings shall be published according to BAPCO's generally applicable publishing policies and standards.

(f) BAPCO shall solicit, accept and publish directory advertising from business subscribers of CARRIER in communities for which BAPCO publishes classified Directories in the same manner and upon the same terms as it solicits, accepts and publishes advertising from advertisers who are not CARRIER subscribers. Except for subscriber information actually published in a Directory, BAPCO shall not use any subscriber information provided to it by CARRIER, for the solicitation of business for other carriers.

(g) BAPCO shall not provide listing information relating to CARRIER subscribers to other local exchange service providers or independent directory publishers without CARRIER approval, except as may be required in relation to this Agreement or as otherwise required by law.

4. **PUBLISHING POLICIES.** BAPCO shall maintain full authority over its publishing schedules, policies, standards, and practices and over the scope and publishing schedules of its Directories. BAPCO shall periodically provide CARRIER with changes by BAPCO in the same which in BAPCO's judgment affect CARRIER's conduct in BAPCO's publishing of listings for CARRIER's subscribers. Such policy updates shall include, without limitation, the subjects described in Exhibit C.

5. **LIABILITY AND INDEMNITY.**

(a) CARRIER agrees to defend, indemnify and hold harmless BAPCO from all damages, claims, suits, losses or expenses, including without limitation reasonable costs and attorneys' fees, arising out of or resulting from any error in or omission of any residential or business listing for subscribers of CARRIER to the extent such error or omission is caused by CARRIER's failure to provide accurate subscriber information to BAPCO.

(b) BAPCO agrees to defend, indemnify and hold harmless AT&T from all damages, claims, suits, losses or expenses, including without limitation reasonable costs and attorneys' fees, arising out of or resulting from: (i) any error in or omission of any paid advertising for subscribers of CARRIER other than those errors caused by CARRIER's failure to provide accurate subscriber information to BAPCO; provided, however, that BAPCO agrees that, where permitted by law, its advertising contracts with CARRIER's subscribers shall limit liability of BAPCO and CARRIER for errors and omissions to a rebate of advertising charges for the advertising containing the error or omission (inclusion of such limitation of CARRIER's liability to be undertaken in BAPCO's normal course of business); or (ii) any error in or omission of any business listing for subscribers of CARRIER to the extent such error or omission is caused by BAPCO's failure to publish correctly such subscriber information provided by CARRIER; provided, however, that notwithstanding the foregoing, BAPCO's liability to CARRIER for any claims relating to or arising from errors in or omissions of residential subscriber listings shall be limited to One Dollar (\$1.00) for each such claim.

(c) Except as provided above, each party agrees to defend, indemnify and hold harmless the other from all damages, claims, suits, losses or expenses, including without limitation reasonable costs and reasonable attorney's fees, to the extent of such party's relative fault, arising out of or resulting from any error, omission or act of such party hereunder. Each party shall notify in writing the other promptly of any act or omission which may give rise to a claim hereunder, and of any claim or suit arising hereunder. Each party shall provide reasonable and timely cooperation in its resolution of any claim or lawsuit arising hereunder. Without waiver of any rights hereunder, the indemnified party may at its expense undertake its own defense in any such claim or suit.

(d) Notwithstanding anything in this Section 5 to the contrary, in no event shall either party be liable to the other or to any third party for any special, incidental or consequential damages or any loss of profits.

(e) CARRIER agrees to include in any local service tariff it files a provision limiting its liability and that of BAPCO, for any claims relating to directory listings or advertisements, to the subscribers' cost of local service or to the charge for any such listing, whichever is less.

6. TERM. This Agreement shall be effective on the date of the last signature hereto for a term of two (2) years and shall relate to Directories published by BAPCO during such period. Thereafter, it shall continue in effect unless terminated by either party upon sixty days prior written notice.

7. ASSIGNMENT. This Agreement shall be binding upon any successors or assigns of the parties during its Term.

8. RELATIONSHIP OF THE PARTIES. This Agreement does not create any joint venture, partnership or employment relationship between the parties or their employees, and the relationship between the parties shall be that of an independent contractor. There shall be no intended third party beneficiaries to this Agreement.

9. NONDISCLOSURE.

(a) During the term of this Agreement it may be necessary for the parties to provide each other with certain information ("Information") considered to be private or proprietary. The recipient shall protect such Information from distribution, disclosure or dissemination to anyone except its employees or contractors with a need to know such Information in conjunction herewith, except as otherwise authorized in writing. All such Information shall be in writing or other tangible form and clearly marked with a confidential or proprietary legend. Information conveyed orally shall be designated as proprietary or confidential at the time of such oral conveyance and shall be reduced to writing within forty-five (45) days.

(b) The parties will not have an obligation to protect any portion of Information which: (1) is made publicly available lawfully by a nonparty to this Agreement; (2) is lawfully obtained from any source other than the providing party; (3) is previously known without an obligation to keep it confidential; (4) is released by the providing party in writing; or (5) commencing two (2) years after the termination date of this Agreement if such Information is not a trade secret under applicable law.

(c) Each party will make copies of the Information only as necessary for its use under the terms hereof, and each such copy will be marked with the same proprietary notices as appear on the originals. Each party agrees to use the Information solely in support of this Agreement and for no other purpose.

10. **FORCE MAJEURE.** Neither party shall be responsible to the other for any delay or failure to perform hereunder to the extent caused by fire, flood, explosion, war, strike, riot, embargo, governmental requirements, civic or military authority, act of God, or other similar cause beyond its reasonable control. Each party shall use best efforts to notify the other promptly of any such delay or failure and shall provide reasonable cooperation to ameliorate the effects thereof.

11. **PUBLICITY.** Neither party shall disclose the terms of this Agreement nor use the trade names or trademarks of the other without the prior express written consent of the other.

12. **REPRESENTATIVES AND NOTICES.**

(a) Each party shall name one or more representatives for contacts between the parties which shall be authorized to act on its behalf. Such representatives may be changed from time to time upon written notice to the other party.

(b) Notices required by law or under this Agreement shall be given in writing by hand delivery, certified or registered mail, or by facsimile followed by certified or registered mail, addressed to the named representatives of the parties with copies to:

If to BAPCO: Director-LEC/BST Interface
 BellSouth Advertising & Publishing Corporation
 Room 270
 59 Executive Park South
 Atlanta, GA 30329

With Copy to: Vice President and General Counsel
BellSouth Advertising & Publishing Corporation
Room 430
59 Executive Park South
Atlanta, GA 30329

If to CARRIER: Bill White
1200 Peachtree Street, NE
Atlanta, GA 30309

With Copy to: Norman H. Rosner
Senior Attorney
1200 Peachtree St., NE
Room 4080
Atlanta, GA 30309

13. **BINDING NATURE.** AT&T agrees to provide a letter substantially in the form attached as Exhibit "D" to all regulatory or legal bodies in which it has filed requests for arbitration or other action concerning directory issues affecting BAPCO.

14. **MISCELLANEOUS.** This Agreement represents the entire Agreement between the parties with respect to the subject matter hereof and supersedes any previous oral or written communications, representations, understandings, or agreements with respect thereto. It may be executed in counterparts, each of which shall be deemed an original. All prior and contemporaneous written or oral agreements, representations, warranties, statements, negotiations, and /or understandings by and between the parties, whether express or implied, are superseded, and there are no representations or warranties, either oral or written, express or implied, not herein contained. This Agreement shall be governed by the laws of the state of Georgia.

IN WITNESS WHEREOF, the parties have executed this Agreement by their duly authorized representatives in one or more counterparts, each of which shall constitute an original, on the dates set forth below.

BELLSOUTH ADVERTISING &
PUBLISHING CORPORATION

By: [Signature]

Title: Executive Vice President

Date: 8/14/96

AT&T CORP.

By: [Signature]

Title: VICE PRESIDENT

Date: 8/14/96

EXHIBIT A

ACCOUNT INFORMATION SECTION (Items in this section are mandatory)

1. Main Telephone Number: Main line of telephone service that all other numbers are associated to. (Area Code/NXX/Line Numbers)
2. Published Telephone Number: Telephone number to appear in the directory.
3. Old Telephone Number: If the number is changing, enter the OLD Telephone Number.
4. Type of Directory Service: Bus (Business) or Res (Residence)
5. Order Type: N - New connect order; D - Disconnect service order; C - Change of listings; R - Directory delivery only.
6. Due Date: Date that service is requested.
7. Carrier Name: The name of the local exchange carrier and operating company code.
8. Carrier Number: Operating Company Number

PRIMARY LISTING INFORMATION SECTION (Items in this section are mandatory)

9. Listed Name: The way the listing is to appear in the directory. (maximum 1,000 characters - including spaces) Caption arrangements should be formatted per guidelines. Non-Pub or Non-List situations should be indicated.
10. Listed Address: Current address may include street number - street name, city, state, and zip code. (Note: P.O. Box or Route not acceptable). Omitted address shown as (OAD). (maximum 250 characters)
11. Service Address: Physical location of the telephone.
12. Community Name: The name of the community where the listing appears. (i.e.: the Atlanta Directory may have a Community name of Buckhead).
13. Zip code: 5 or 9 character code.
14. Yellow Pages Heading: The Yellow Page heading where customer wants his listing to appear. (Valid for Business Primary Listings only).
15. Directory Name: Name of the directory where Customer desires listing to appear (including town section if applicable). If consistent with existing central office and directory configuration, listing will be included. If different, a Foreign Listing will be charged. Directory appearance entitled free is based on the central office prefix. Entitlement for appearance in other directories will be at the rate of a Foreign Listing (FL).

BILLING INFORMATION SECTION (Items in this section are requested but optional)

16. Billing: Name to appear on bill.
17. Billing Address: Street number, street name, city, state, zip.
18. Contact Telephone Number: Telephone number to contact regarding billing.
19. Responsible Person: Owner's name or partners' names or 2 corporate officers.
20. Type of Ownership: Sole owner; Partnership or Corporation
21. Tax ID Number or Social Security Number: If sole owner, must have social security number.

DIRECTORY DELIVERY INFORMATION SECTION (Items in this section are mandatory)

22. Name: Personal or business name.
23. Delivery Address: Street number, street name, city, state, zip code of where directories are to be delivered.

24. Directory (Book ID): Bolt code of the directory.
25. Number of books now: for immediate delivery/replacement.
26. Number of books annually: 0 - 3 residence, 0 - 5 business, then negotiated.

REMARKS SECTION (As required)

27. Remarks: Free flow field used by Carrier for any additional information

PRIVATE/PROPRIETARY

Contains private and/or proprietary information. May not be used or disclosed outside the BellSouth companies except pursuant to a written agreement.

BAPCO Deliverables

Publication Schedules

BAPCO will provide to all carriers a printed copy of the publication schedules for all directories within the area served by the carrier. This schedule will include the name of the directory, the directory bolt code, the business office close date and the issue date. The business office close date represents the last day to receive activity for appearance in the subsequent directory. This date also represents the close date for advertising activity into the Yellow Pages.

The issue date represents the mid-point of delivery of the new directory and the date at which new directory billing will begin for the directory being delivered. The length of the delivery period will vary depending upon the size of directory.

Yellow Pages Headings

BAPCO will provide a printed version of the Yellow Pages Heading file which will include all Yellow Pages headings allowed by BAPCO, the Yellow Pages heading code and the associated SIC code. This material would be utilized to assist the business customer in identifying where they would like representation in BAPCO's classified Yellow Pages directories.

Coverage Maps

BAPCO will provide a coverage map for its major directories identifying broadly the geographic area served by the major directory. These maps will be provided only for the major directories in the area served by the carrier.

Central Office Table

BAPCO will provide two printed versions of what is called the ABC table. Version 1 of this report, identifies by NPA and in sequence by central office in which directory a customer is entitled to appear. Version 2 of this report reflects the directory name and all central offices appearing within that directory.

Listing Specifications

BAPCO will provide a condensed printed version of listing specifications reflecting the rules and regulations regarding listing appearance in both the white and yellow pages.

Abbreviation Table

BAPCO will provide a printed copy of the standard abbreviations utilized for given names, titles of address, titles of lineage, military titles, degrees and professional affiliations standards. This information can be used to assist in effectively processing various listed name requests.

Foreign Directory Name Table

BAPCO will provide a list of all foreign directory names to be used in the processing of foreign listing requests. This field is a required element in the establishment of foreign listings.

Customer Guide Pages Appearance Procedures

BAPCO will provide free listing appearance under the areas of Establishing Service, Billing and Repair in the Customer Guide Section of the White Pages for directories where a carrier operates. These procedures identify how to get your listing to appear and procedures for purchasing LEC specific pages.

The parties acknowledge and agree that for the Directory coverage areas listed below, CARRIER shall warrant to BAPCO in writing its good faith intent to commence offering local exchange service in such Directory coverage areas for no less than three (3) months of the effective Directory service period:

[LIST AREAS]

AT&T LETTER TO PSC'S

Dear _____:

Tele This is to advise that AT&T has reached agreement with BellSouth Advertising & Publishing Corporation ("BAPCO") concerning any and all directory issues raised in our previous filings requesting arbitration by the Commission (Authority in Tennessee) other than AT&T's right to place its name on the cover of directories published by BAPCO on the same terms and conditions and in the same size and format as that of BellSouth Communications, Inc. We withdraw all other directory issues from the prior requests submitted to the Commission.

cc: BAPCO