

# **BELLSOUTH® / CLEC Agreement**

## **Customer Name: Delta Communications, LLC dba Clearwave Communications**

Delta Communications, LLC dba Clearwave Communications - 2003 Contract	2
Table of Contents	3
General Terms and Conditions	5
Signature Page	25
Att 1 - Resale	26
Att 1 - Resale Discounts and Rates	54
Att 2 - UNEs	55
Att 2 - UNE Rates	134
Att 3 - Network Interconnection	172
Att 3 - Local Interconnection Rates	203
Att 4 - Collocation - Central Office	204
Att 4 - Collocation - Remote Site	248
Att 4 - Collocation Rates	285
Att 5 - Access to Numbers and Number Portability	290
Att 6 - Ordering	294
Att 7 - Billing	301
Att 7 - ODUF ADUF EODUF CMDS Rates	320
Att 8 - Rights of Way	321
Att 9 - Perf Meas Intro	323
Att 10 - Disaster Recovery Plan	325
Att 11 - BFR and NBR Process	334

**Interconnection Agreement**

**Between**

**BellSouth Telecommunications, Inc.**

**and**

**Delta Communications, LLC d/b/a Clearwave Communications**

## **TABLE OF CONTENTS**

### **General Terms and Conditions**

- Definitions
- 1. CLEC Certification
- 2. Term of the Agreement
- 3. Operational Support Systems
- 4. Parity
- 5. White Pages Listings
- 6. Court Ordered Requests for Call Detail Records and Other Subscriber Information
- 7. Liability and Indemnification
- 8. Intellectual Property Rights and Indemnification
- 9. Proprietary and Confidential Information
- 10. Resolution of Disputes
- 11. Taxes
- 12. Force Majeure
- 13. Adoption of Agreements
- 14. Modification of Agreement
- 15. Non-waiver of Legal Rights
- 16. Indivisibility
- 17. Waivers
- 18. Governing Law
- 19. Assignments
- 20. Notices
- 21. Rule of Construction
- 22. Headings of No Force or Effect
- 23. Multiple Counterparts
- 24. Filing of Agreement
- 25. Compliance with Applicable Law
- 26. Necessary Approvals
- 27. Good Faith Performance
- 28. Nonexclusive Dealings
- 29. Rate True-Up
- 30. Survival
- 31. Entire Agreement

## **TABLE OF CONTENTS (cont'd)**

**Attachment 1 - Resale**

**Attachment 2 - Network Elements and Other Services**

**Attachment 3 - Network Interconnection**

**Attachment 4 - Physical Collocation**

**Attachment 5 - Access to Numbers and Number Portability**

**Attachment 6 – Pre-Ordering, Ordering, Provisioning, Maintenance and Repair**

**Attachment 7 - Billing**

**Attachment 8 - Rights-of-Way, Conduits and Pole Attachments**

**Attachment 9 - Performance Measurements**

**Attachment 10- BellSouth Disaster Recovery Plan**

**Attachment 11–Bona Fide Request/New Business Request Process**

## **AGREEMENT GENERAL TERMS AND CONDITIONS**

**THIS AGREEMENT** is made by and between BellSouth Telecommunications, Inc., (BellSouth), a Georgia corporation, and Delta Communications, LLC d/b/a Clearwave Communications (Clearwave Communications), an Illinois Limited Liability Company, and shall be effective on the Effective Date, as defined herein. This Agreement may refer to either BellSouth or Clearwave Communications or both as a “Party” or “Parties.”

### **W I T N E S S E T H**

**WHEREAS**, BellSouth is a local exchange telecommunications company authorized to provide telecommunications services in the state of Kentucky; and

**WHEREAS**, Clearwave Communications is or seeks to become a CLEC authorized to provide telecommunications services in the state of Kentucky; and

**WHEREAS**, Clearwave Communications wishes to resell BellSouth’s telecommunications services and purchase network elements and other services, and, solely in connection therewith, may wish to utilize collocation space as set forth in Attachment 4 of this Agreement); and

**WHEREAS**, the Parties wish to interconnect their facilities and exchange traffic pursuant to Sections 251 and 252 of the Act.

**NOW THEREFORE**, in consideration of the mutual agreements contained herein, BellSouth and Clearwave Communications agree as follows:

#### **Definitions**

**Affiliate** is defined as a person that (directly or indirectly) owns or controls, is owned or controlled by, or is under common ownership or control with, another person. For purposes of this paragraph, the term “own” means to own an equity interest (or equivalent thereof) of more than 10 percent.

**Commission** is defined as the appropriate regulatory agency in each state of BellSouth’s nine-state region (Alabama, Florida, Georgia, Kentucky, Louisiana, Mississippi, North Carolina, South Carolina, and Tennessee).

**Competitive Local Exchange Carrier (CLEC)** means a telephone company certificated by the Commission to provide local exchange service within BellSouth’s franchised area.

**Effective Date** is defined as the date that the Agreement is effective for purposes of rates, terms and conditions and shall be thirty (30) days after the date of the last signature executing the Agreement. Future amendments for rate changes will also be effective thirty (30) days after the date of the last signature executing the amendment.

**End User** means the ultimate user of the Telecommunications Service.

**FCC** means the Federal Communications Commission.

**General Terms and Conditions** means this document including all of the terms, provisions and conditions set forth herein.

**Telecommunications** means the transmission, between or among points specified by the user, of information of the user's choosing, without change in the form or content of the information as sent and received.

**Telecommunications Service** means the offering of telecommunications for a fee directly to the public, or to such classes of users as to be effectively available directly to the public, regardless of the facilities used.

**Telecommunications Act of 1996 (Act)** means Public Law 104-104 of the United States Congress effective February 8, 1996. The Act amended the Communications Act of 1934 (47 U.S.C. Section 1 et. seq.).

## 1. **CLEC Certification**

- 1.1 Prior to execution of this Agreement, Clearwave Communications agrees to provide BellSouth in writing Clearwave Communications's CLEC certification for all states covered by this Agreement except Kentucky prior to BellSouth filing this Agreement with the appropriate Commission for approval.
- 1.2 To the extent Clearwave Communications is not certified as a CLEC in each state covered by this Agreement as of the execution hereof, Clearwave Communications will notify BellSouth in writing and provide CLEC certification when it becomes certified to operate in any other state covered by this Agreement. Upon notification, BellSouth will file this Agreement with the appropriate Commission for approval.

## 2. **Term of the Agreement**

- 2.1 The term of this Agreement shall be two years, beginning on the Effective Date and shall apply to the BellSouth territory in the state of Kentucky. Notwithstanding any prior agreement of the Parties, the rates, terms and conditions of this Agreement shall not be applied retroactively prior to the Effective Date.

- 2.2 The Parties agree that by no earlier than two hundred seventy (270) days and no later than one hundred and eighty (180) days prior to the expiration of this Agreement, they shall commence negotiations for a new agreement to be effective beginning on the expiration date of this Agreement (Subsequent Agreement).
- 2.3 If, within one hundred and thirty-five (135) days of commencing the negotiation referred to in Section 2.2 above, the Parties are unable to negotiate new terms, conditions and prices for a Subsequent Agreement, either Party may petition the Commission to establish appropriate terms, conditions and prices for the Subsequent Agreement pursuant to 47 U.S.C. 252.
- 2.4 If, as of the expiration of this Agreement, a Subsequent Agreement has not been executed by the Parties, this Agreement shall terminate. Upon termination of this Agreement, BellSouth shall continue to offer services to Clearwave Communications pursuant to the terms, conditions and rates set forth in BellSouth's then current standard interconnection agreement. In the event that BellSouth's standard interconnection agreement becomes effective as between the Parties, the Parties may continue to negotiate a Subsequent Agreement or arbitrate disputed issues to reach a Subsequent Agreement as set forth in Section 2.3 above, and the terms of such Subsequent Agreement shall be effective as of the effective date as stated in the Subsequent Agreement.

### **3. Operational Support Systems**

Clearwave Communications shall pay charges for Operational Support Systems (OSS) as set forth in this Agreement.

### **4. Parity**

When Clearwave Communications purchases Telecommunications Services from BellSouth pursuant to Attachment 1 of this Agreement for the purposes of resale to End Users, such services shall be equal in quality, subject to the same conditions, and provided within the same provisioning time intervals that BellSouth provides to its Affiliates, subsidiaries and End Users. To the extent technically feasible, the quality of a Network Element, as well as the quality of the access to such Network Element provided by BellSouth to Clearwave Communications shall be at least equal in quality to that which BellSouth provides to itself, its Affiliates or any other Telecommunications carrier. The quality of the interconnection between the network of BellSouth and the network of Clearwave Communications shall be at a level that is equal to that which BellSouth provides itself, a subsidiary, an Affiliate, or any other party. The interconnection facilities shall be designed to meet the same technical criteria and service standards that are used within BellSouth's network and shall extend to a consideration of service quality as perceived by BellSouth's End Users and service quality as perceived by Clearwave Communications.

### **5. White Pages Listings**

- 5.1 BellSouth shall provide Clearwave Communications and its customers access to white pages directory listings under the following terms:
- 5.1.1 Listings. Clearwave Communications shall provide all new, changed and deleted listings on a timely basis and BellSouth or its agent will include Clearwave Communications residential and business customer listings in the appropriate White Pages (residential and business) or alphabetical directories in the geographic areas covered by this Interconnection Agreement. Directory listings will make no distinction between Clearwave Communications and BellSouth subscribers.
- 5.1.2 Rates. So long as Clearwave Communications provides subscriber listing information (SLI) to BellSouth in accordance with Section 5.2 below, BellSouth shall provide to Clearwave Communications one (1) primary White Pages listing per Clearwave Communications subscriber at no charge other than applicable service order charges as set forth in BellSouth's tariffs.
- 5.2 Procedures for Submitting Clearwave Communications SLI are found in The BellSouth Business Rules for Local Ordering.
- 5.2.1 Clearwave Communications authorizes BellSouth to release all Clearwave Communications SLI provided to BellSouth by Clearwave Communications to qualifying third parties via either license agreement or BellSouth's Directory Publishers Database Service (DPDS), General Subscriber Services Tariff (GSST), Section A38.2, as the same may be amended from time to time. Such Clearwave Communications SLI shall be intermingled with BellSouth's own customer listings and listings of any other CLEC that has authorized a similar release of SLI.
- 5.2.2 No compensation shall be paid to Clearwave Communications for BellSouth's receipt of Clearwave Communications SLI, or for the subsequent release to third parties of such SLI. In addition, to the extent BellSouth incurs costs to modify its systems to enable the release of Clearwave Communications's SLI, or costs on an ongoing basis to administer the release of Clearwave Communications SLI, Clearwave Communications shall pay to BellSouth its proportionate share of the reasonable costs associated therewith. At any time that costs may be incurred to administer the release of Clearwave Communications's SLI, Clearwave Communications will be notified. If Clearwave Communications does not wish to pay its proportionate share of these reasonable costs, Clearwave Communications may instruct BellSouth that it does not wish to release its SLI to independent publishers, and Clearwave Communications shall amend this Agreement accordingly. Clearwave Communications will be liable for all costs incurred until the effective date of the amendment.
- 5.2.3 Neither BellSouth nor any agent shall be liable for the content or accuracy of any SLI provided by Clearwave Communications under this Agreement. Clearwave Communications shall indemnify, hold harmless and defend BellSouth and its agents from and against any damages, losses, liabilities, demands, claims, suits, judgments, costs and expenses (including but not limited to reasonable attorneys'



fees and expenses) arising from BellSouth's tariff obligations or otherwise and resulting from or arising out of any third party's claim of inaccurate Clearwave Communications listings or use of the SLI provided pursuant to this Agreement. BellSouth may forward to Clearwave Communications any complaints received by BellSouth relating to the accuracy or quality of Clearwave Communications listings.

- 5.2.4 Listings and subsequent updates will be released consistent with BellSouth system changes and/or update scheduling requirements.
- 5.3 Unlisted/Non-Published Subscribers. Clearwave Communications will be required to provide to BellSouth the names, addresses and telephone numbers of all Clearwave Communications customers who wish to be omitted from directories. Unlisted/Non-Published SLI will be subject to the rates as set forth in BellSouth's General Subscriber Services Tariff.
- 5.4 Inclusion of Clearwave Communications End Users in Directory Assistance Database. BellSouth will include and maintain Clearwave Communications subscriber listings in BellSouth's Directory Assistance databases at no recurring charge and Clearwave Communications shall provide such Directory Assistance listings to BellSouth at no recurring charge.
- 5.5 Listing Information Confidentiality. BellSouth will afford Clearwave Communications's directory listing information the same level of confidentiality that BellSouth affords its own directory listing information.
- 5.6 Additional and Designer Listings. Additional and designer listings will be offered by BellSouth at tariffed rates as set forth in the General Subscriber Services Tariff.
- 5.7 Directories. BellSouth or its agent shall make available White Pages directories to Clearwave Communications subscribers at no charge or as specified in a separate agreement with BellSouth's agent.

## **6. Court Ordered Requests for Call Detail Records and Other Subscriber Information**

- 6.1 Subpoenas Directed to BellSouth. Where BellSouth provides resold services or local switching for Clearwave Communications, BellSouth shall respond to subpoenas and court ordered requests delivered directly to BellSouth for the purpose of providing call detail records when the targeted telephone numbers belong to Clearwave Communications End Users. Billing for such requests will be generated by BellSouth and directed to the law enforcement agency initiating the request. BellSouth shall maintain such information for Clearwave Communications End Users for the same length of time it maintains such information for its own End Users.
- 6.2 Subpoenas Directed to Clearwave Communications. Where BellSouth is providing to Clearwave Communications Telecommunications Services for resale or

providing to Clearwave Communications the local switching function, then Clearwave Communications agrees that in those cases where Clearwave Communications receives subpoenas or court ordered requests regarding targeted telephone numbers belonging to Clearwave Communications End Users, and where Clearwave Communications does not have the requested information, Clearwave Communications will advise the law enforcement agency initiating the request to redirect the subpoena or court ordered request to BellSouth for handling in accordance with 6.1 above.

- 6.3 In all other instances, where either Party receives a request for information involving the other Party's End User, the Party receiving the request will advise the law enforcement agency initiating the request to redirect such request to the other Party.

## **7. Liability and Indemnification**

- 7.1 Clearwave Communications Liability. In the event that Clearwave Communications consists of two (2) or more separate entities as set forth in this Agreement and/or any Amendments hereto, all such entities shall be jointly and severally liable for the obligations of Clearwave Communications under this Agreement.

- 7.2 Liability for Acts or Omissions of Third Parties. BellSouth shall not be liable to Clearwave Communications for any act or omission of another Telecommunications company providing services to Clearwave Communications.

### 7.3 Limitation of Liability

- 7.3.1 Except for any indemnification obligations of the Parties hereunder, each Party's liability to the other for any loss, cost, claim, injury, liability or expense, including reasonable attorneys' fees relating to or arising out of any negligent act or omission in its performance of this Agreement, whether in contract or in tort, shall be limited to a credit for the actual cost of the services or functions not performed or improperly performed.

- 7.3.2 Limitations in Tariffs. A Party may, in its sole discretion, provide in its tariffs and contracts with its End Users and third parties that relate to any service, product or function provided or contemplated under this Agreement, that to the maximum extent permitted by Applicable Law, such Party shall not be liable to the End User or third party for (i) any loss relating to or arising out of this Agreement, whether in contract, tort or otherwise, that exceeds the amount such Party would have charged that applicable person for the service, product or function that gave rise to such loss and (ii) consequential damages. To the extent that a Party elects not to place in its tariffs or contracts such limitations of liability, and the other Party incurs a loss as a result thereof, such Party shall indemnify and reimburse the other Party for that portion of the loss that would have been limited had the first Party

included in its tariffs and contracts the limitations of liability that such other Party included in its own tariffs at the time of such loss.

- 7.3.3 Neither BellSouth nor Clearwave Communications shall be liable for damages to the other Party's terminal location, equipment or End User premises resulting from the furnishing of a service, including, but not limited to, the installation and removal of equipment or associated wiring, except to the extent caused by a Party's negligence or willful misconduct or by a Party's failure to ground properly a local loop after disconnection.
- 7.3.4 Under no circumstance shall a Party be responsible or liable for indirect, incidental, or consequential damages, including, but not limited to, economic loss or lost business or profits, damages arising from the use or performance of equipment or software, or the loss of use of software or equipment, or accessories attached thereto, delay, error, or loss of data. In connection with this limitation of liability, each Party recognizes that the other Party may, from time to time, provide advice, make recommendations, or supply other analyses related to the services or facilities described in this Agreement, and, while each Party shall use diligent efforts in this regard, the Parties acknowledge and agree that this limitation of liability shall apply to provision of such advice, recommendations, and analyses.
- 7.3.5 To the extent any specific provision of this Agreement purports to impose liability, or limitation of liability, on either Party different from or in conflict with the liability or limitation of liability set forth in this Section, then with respect to any facts or circumstances covered by such specific provisions, the liability or limitation of liability contained in such specific provision shall apply.
- 7.4 Indemnification for Certain Claims. The Party providing services hereunder, its Affiliates and its parent company, shall be indemnified, defended and held harmless by the Party receiving services hereunder against any claim, loss or damage arising from the receiving Party's use of the services provided under this Agreement pertaining to (1) claims for libel, slander or invasion of privacy arising from the content of the receiving Party's own communications, or (2) any claim, loss or damage claimed by the End User of the Party receiving services arising from such company's use or reliance on the providing Party's services, actions, duties, or obligations arising out of this Agreement.
- 7.5 Disclaimer. EXCEPT AS SPECIFICALLY PROVIDED TO THE CONTRARY IN THIS AGREEMENT, NEITHER PARTY MAKES ANY REPRESENTATIONS OR WARRANTIES TO THE OTHER PARTY CONCERNING THE SPECIFIC QUALITY OF ANY SERVICES, OR FACILITIES PROVIDED UNDER THIS AGREEMENT. THE PARTIES DISCLAIM, WITHOUT LIMITATION, ANY WARRANTY OR GUARANTEE OF MERCHANTABILITY OR FITNESS FOR A PARTICULAR PURPOSE, ARISING FROM COURSE OF PERFORMANCE, COURSE OF DEALING, OR FROM USAGES OF TRADE.

## 8. Intellectual Property Rights and Indemnification

- 8.1 No License. No patent, copyright, trademark or other proprietary right is licensed, granted or otherwise transferred by this Agreement. The Parties are strictly prohibited from any use, including but not limited to, in the selling, marketing, promoting or advertising of telecommunications services, of any name, service mark, logo or trademark (collectively, the “Marks”) of the Other Party. The Marks include those Marks owned directly by a Party or its Affiliate(s) and those Marks that a Party has a legal and valid license to use. The Parties acknowledge that they are separate and distinct and that each provides a separate and distinct service and agree that neither Party may, expressly or impliedly, state, advertise or market that it is or offers the same service as the Other Party or engage in any other activity that may result in a likelihood of confusion between its own service and the service of the Other Party.
- 8.2 Ownership of Intellectual Property. Any intellectual property that originates from or is developed by a Party shall remain the exclusive property of that Party. Except for a limited, non-assignable, non-exclusive, non-transferable license to use patents or copyrights to the extent necessary for the Parties to use any facilities or equipment (including software) or to receive any service solely as provided under this Agreement, no license in patent, copyright, trademark or trade secret, or other proprietary or intellectual property right, now or hereafter owned, controlled or licensable by a Party, is granted to the other Party. Neither shall it be implied nor arise by estoppel. Any trademark, copyright or other proprietary notices appearing in association with the use of any facilities or equipment (including software) shall remain on the documentation, material, product, service, equipment or software. It is the responsibility of each Party to ensure at no additional cost to the other Party that it has obtained any necessary licenses in relation to intellectual property of third Parties used in its network that may be required to enable the other Party to use any facilities or equipment (including software), to receive any service, or to perform its respective obligations under this Agreement.
- 8.3 Intellectual Property Remedies
- 8.3.1 Indemnification. The Party providing a service pursuant to this Agreement will defend the Party receiving such service or data provided as a result of such service against claims of infringement arising solely from the use by the receiving Party of such service in the manner contemplated under this Agreement and will indemnify the receiving Party for any damages awarded based solely on such claims in accordance with Section 7 preceding.
- 8.3.2 Claim of Infringement. In the event that use of any facilities or equipment (including software), becomes, or in the reasonable judgment of the Party who owns the affected network is likely to become, the subject of a claim, action, suit, or proceeding based on intellectual property infringement, then said Party shall promptly and at its sole expense and sole option, but subject to the limitations of liability set forth below:

- 8.3.2.1 modify or replace the applicable facilities or equipment (including software) while maintaining form and function, or
- 8.3.2.2 obtain a license sufficient to allow such use to continue.
- 8.3.2.3 In the event Section 8.3.2.1 or 8.3.2.2 are commercially unreasonable, then said Party may terminate, upon reasonable notice, this contract with respect to use of, or services provided through use of, the affected facilities or equipment (including software), but solely to the extent required to avoid the infringement claim.
- 8.3.3 Exception to Obligations. Neither Party's obligations under this Section shall apply to the extent the infringement is caused by: (i) modification of the facilities or equipment (including software) by the indemnitee; (ii) use by the indemnitee of the facilities or equipment (including software) in combination with equipment or facilities (including software) not provided or authorized by the indemnitor, provided the facilities or equipment (including software) would not be infringing if used alone; (iii) conformance to specifications of the indemnitee which would necessarily result in infringement; or (iv) continued use by the indemnitee of the affected facilities or equipment (including software) after being placed on notice to discontinue use as set forth herein.
- 8.3.4 Exclusive Remedy. The foregoing shall constitute the Parties' sole and exclusive remedies and obligations with respect to a third party claim of intellectual property infringement arising out of the conduct of business under this Agreement.
- 8.4 Dispute Resolution. Any claim arising under this Section 8 shall be excluded from the dispute resolution procedures set forth in Section 10 and shall be brought in a court of competent jurisdiction.

## **9. Proprietary and Confidential Information**

- 9.1 Proprietary and Confidential Information. It may be necessary for BellSouth and Clearwave Communications, each as the "Discloser," to provide to the other Party, as "Recipient," certain proprietary and confidential information (including trade secret information) including but not limited to technical, financial, marketing, staffing and business plans and information, strategic information, proposals, request for proposals, specifications, drawings, maps, prices, costs, costing methodologies, procedures, processes, business systems, software programs, techniques, customer account data, call detail records and like information (collectively the "Information"). All such Information conveyed in writing or other tangible form shall be clearly marked with a confidential or proprietary legend. Information conveyed orally by the Discloser to Recipient shall be designated as proprietary and confidential at the time of such oral conveyance, shall be reduced to writing by the Discloser within forty-five (45) days thereafter, and shall be clearly marked with a confidential or proprietary legend.
- 9.2 Use and Protection of Information. Recipient agrees to protect such Information of the Discloser provided to Recipient from whatever source from distribution,

disclosure or dissemination to anyone except employees of Recipient with a need to know such Information solely in conjunction with Recipient's analysis of the Information and for no other purpose except as authorized herein or as otherwise authorized in writing by the Discloser. Recipient will not make any copies of the Information inspected by it.

- 9.3 Exceptions. Recipient will not have an obligation to protect any portion of the Information which:
- 9.3.1 (a) is made publicly available by the Discloser or lawfully by a nonparty to this Agreement; (b) is lawfully obtained by Recipient from any source other than Discloser; (c) is previously known to Recipient without an obligation to keep it confidential; or (d) is released from the terms of this Agreement by Discloser upon written notice to Recipient.
- 9.4 Recipient agrees to use the Information solely for the purposes of negotiations pursuant to 47 U.S.C. 251 or in performing its obligations under this Agreement and for no other entity or purpose, except as may be otherwise agreed to in writing by the Parties. Nothing herein shall prohibit Recipient from providing information requested by the FCC or a state regulatory agency with jurisdiction over this matter, or to support a request for arbitration or an allegation of failure to negotiate in good faith.
- 9.5 Recipient agrees not to publish or use the Information for any advertising, sales or marketing promotions, press releases, or publicity matters that refer either directly or indirectly to the Information or to the Discloser or any of its affiliated companies.
- 9.6 The disclosure of Information neither grants nor implies any license to the Recipient under any trademark, patent, copyright, application or other intellectual property right that is now or may hereafter be owned by the Discloser.
- 9.7 Survival of Confidentiality Obligations. The Parties' rights and obligations under this Section 9 shall survive and continue in effect until two (2) years after the expiration or termination date of this Agreement with regard to all Information exchanged during the term of this Agreement. Thereafter, the Parties' rights and obligations hereunder survive and continue in effect with respect to any Information that is a trade secret under applicable law.

## 10. **Resolution of Disputes**

Except as otherwise stated in this Agreement, if any dispute arises as to the interpretation of any provision of this Agreement or as to the proper implementation of this Agreement, the aggrieved Party shall petition the Commission for a resolution of the dispute. However, each Party reserves any

rights it may have to seek judicial review of any ruling made by the Commission concerning this Agreement.

## **11. Taxes**

11.1 Definition. For purposes of this Section, the terms “taxes” and “fees” shall include but not be limited to federal, state or local sales, use, excise, gross receipts or other taxes or tax-like fees of whatever nature and however designated (including tariff surcharges and any fees, charges or other payments, contractual or otherwise, for the use of public streets or rights of way, whether designated as franchise fees or otherwise) imposed, or sought to be imposed, on or with respect to the services furnished hereunder or measured by the charges or payments therefore, excluding any taxes levied on income.

### 11.2 Taxes and Fees Imposed Directly On Either Providing Party or Purchasing Party.

11.2.1 Taxes and fees imposed on the providing Party, which are not permitted or required to be passed on by the providing Party to its customer, shall be borne and paid by the providing Party.

11.2.2 Taxes and fees imposed on the purchasing Party, which are not required to be collected and/or remitted by the providing Party, shall be borne and paid by the purchasing Party.

### 11.3 Taxes and Fees Imposed on Purchasing Party But Collected And Remitted By Providing Party.

11.3.1 Taxes and fees imposed on the purchasing Party shall be borne by the purchasing Party, even if the obligation to collect and/or remit such taxes or fees is placed on the providing Party.

11.3.2 To the extent permitted by applicable law, any such taxes and/or fees shall be shown as separate items on applicable billing documents between the Parties. Notwithstanding the foregoing, the purchasing Party shall remain liable for any such taxes and fees regardless of whether they are actually billed by the providing Party at the time that the respective service is billed.

11.3.3 If the purchasing Party determines that in its opinion any such taxes or fees are not payable, the providing Party shall not bill such taxes or fees to the purchasing Party if the purchasing Party provides written certification, reasonably satisfactory to the providing Party, stating that it is exempt or otherwise not subject to the tax or fee, setting forth the basis therefor, and satisfying any other requirements under applicable law. If any authority seeks to collect any such tax or fee that the purchasing Party has determined and certified not to be payable, or any such tax or fee that was not billed by the providing Party, the purchasing Party may contest the same in good faith, at its own expense. In any such contest, the purchasing Party shall promptly furnish the providing Party with copies of all filings in any

proceeding, protest, or legal challenge, all rulings issued in connection therewith, and all correspondence between the purchasing Party and the taxing authority.

- 11.3.4 In the event that all or any portion of an amount sought to be collected must be paid in order to contest the imposition of any such tax or fee, or to avoid the existence of a lien on the assets of the providing Party during the pendency of such contest, the purchasing Party shall be responsible for such payment and shall be entitled to the benefit of any refund or recovery.
- 11.3.5 If it is ultimately determined that any additional amount of such a tax or fee is due to the imposing authority, the purchasing Party shall pay such additional amount, including any interest and penalties thereon.
- 11.3.6 Notwithstanding any provision to the contrary, the purchasing Party shall protect, indemnify and hold harmless (and defend at the purchasing Party's expense) the providing Party from and against any such tax or fee, interest or penalties thereon, or other charges or payable expenses (including reasonable attorney fees) with respect thereto, which are incurred by the providing Party in connection with any claim for or contest of any such tax or fee.
- 11.3.7 Each Party shall notify the other Party in writing of any assessment, proposed assessment or other claim for any additional amount of such a tax or fee by a taxing authority; such notice to be provided, if possible, at least ten (10) days prior to the date by which a response, protest or other appeal must be filed, but in no event later than thirty (30) days after receipt of such assessment, proposed assessment or claim.
- 11.4 Taxes and Fees Imposed on Providing Party But Passed On To Purchasing Party.
- 11.4.1 Taxes and fees imposed on the providing Party, which are permitted or required to be passed on by the providing Party to its customer, shall be borne by the purchasing Party.
- 11.4.2 To the extent permitted by applicable law, any such taxes and/or fees shall be shown as separate items on applicable billing documents between the Parties. Notwithstanding the foregoing, the purchasing Party shall remain liable for any such taxes and fees regardless of whether they are actually billed by the providing Party at the time that the respective service is billed.
- 11.4.3 If the purchasing Party disagrees with the providing Party's determination as to the application or basis for any such tax or fee, the Parties shall consult with respect to the imposition and billing of such tax or fee. Notwithstanding the foregoing, the providing Party shall retain ultimate responsibility for determining whether and to what extent any such taxes or fees are applicable, and the purchasing Party shall abide by such determination and pay such taxes or fees to the providing Party. The providing Party shall further retain ultimate responsibility for determining whether and how to contest the imposition of such taxes and fees; provided,



however, that any such contest undertaken at the request of the purchasing Party shall be at the purchasing Party's expense.

- 11.4.4 In the event that all or any portion of an amount sought to be collected must be paid in order to contest the imposition of any such tax or fee, or to avoid the existence of a lien on the assets of the providing Party during the pendency of such contest, the purchasing Party shall be responsible for such payment and shall be entitled to the benefit of any refund or recovery.
- 11.4.5 If it is ultimately determined that any additional amount of such a tax or fee is due to the imposing authority, the purchasing Party shall pay such additional amount, including any interest and penalties thereon.
- 11.4.6 Notwithstanding any provision to the contrary, the purchasing Party shall protect, indemnify and hold harmless (and defend at the purchasing Party's expense) the providing Party from and against any such tax or fee, interest or penalties thereon, or other reasonable charges or payable expenses (including reasonable attorneys' fees) with respect thereto, which are incurred by the providing Party in connection with any claim for or contest of any such tax or fee.
- 11.4.7 Each Party shall notify the other Party in writing of any assessment, proposed assessment or other claim for any additional amount of such a tax or fee by a taxing authority; such notice to be provided, if possible, at least ten (10) days prior to the date by which a response, protest or other appeal must be filed, but in no event later than thirty (30) days after receipt of such assessment, proposed assessment or claim.
- 11.5 Mutual Cooperation. In any contest of a tax or fee by one Party, the other Party shall cooperate fully by providing records, testimony and such additional information or assistance as may reasonably be necessary to pursue the contest. Further, the other Party shall be reimbursed for any reasonable and necessary out-of-pocket copying and travel expenses incurred in assisting in such contest.

## 12. **Force Majeure**

In the event performance of this Agreement, or any obligation hereunder, is either directly or indirectly prevented, restricted, or interfered with by reason of fire, flood, earthquake or like acts of God, wars, revolution, civil commotion, explosion, acts of public enemy, embargo, acts of the government in its sovereign capacity, labor difficulties, including without limitation, strikes, slowdowns, picketing, or boycotts, unavailability of equipment from vendor, changes requested by Clearwave Communications, or any other circumstances beyond the reasonable control and without the fault or negligence of the Party affected, the Party affected, upon giving prompt notice to the other Party, shall be excused from such performance on a day-to-day basis to the extent of such prevention, restriction, or interference (and the other Party shall likewise be excused from performance of its obligations on a day-to-day basis until the delay, restriction or interference has ceased); provided, however, that the Party so affected shall use diligent efforts to

avoid or remove such causes of non-performance and both Parties shall proceed whenever such causes are removed or cease.

**13. Adoption of Agreements**

BellSouth shall make available, pursuant to 47 USC § 252 and the FCC rules and regulations regarding such availability, to Clearwave Communications any interconnection, service, or network element provided under any other agreement filed and approved pursuant to 47 USC § 252, provided a minimum of six months remains on the term of such agreement. The Parties shall adopt all rates, terms and conditions concerning such other interconnection, service or network element and any other rates, terms and conditions that are legitimately related to or were negotiated in exchange for or in conjunction with the interconnection, service or network element being adopted. The adopted interconnection, service, or network element and agreement shall apply to the same states as such other agreement. The term of the adopted agreement or provisions shall expire on the same date as set forth in the agreement that was adopted.

**14. Modification of Agreement**

14.1 If Clearwave Communications changes its name or makes changes to its company structure or identity due to a merger, acquisition, transfer or any other reason, it is the responsibility of Clearwave Communications to notify BellSouth of said change and request that an amendment to this Agreement, if necessary, be executed to reflect said change.

14.2 No modification, amendment, supplement to, or waiver of the Agreement or any of its provisions shall be effective and binding upon the Parties unless it is made in writing and duly signed by the Parties.

14.3 In the event that any effective legislative, regulatory, judicial or other legal action materially affects any material terms of this Agreement, or the ability of Clearwave Communications or BellSouth to perform any material terms of this Agreement, Clearwave Communications or BellSouth may, on thirty (30) days' written notice, require that such terms be renegotiated, and the Parties shall renegotiate in good faith such mutually acceptable new terms as may be required. In the event that such new terms are not renegotiated within ninety (90) days after such notice, the Dispute shall be referred to the Dispute Resolution procedure set forth in this Agreement.

**15. Non-waiver of Legal Rights**

Execution of this Agreement by either Party does not confirm or imply that the executing Party agrees with any decision(s) issued pursuant to the Telecommunications Act of 1996 and the consequences of those decisions on specific language in this Agreement. Neither Party waives its rights to appeal or otherwise challenge any such decision(s) and each Party reserves all of its rights to pursue any and all legal and/or equitable remedies, including appeals of any such decision(s).

**16. Indivisibility**

The Parties intend that this Agreement be indivisible and nonseverable, and each of the Parties acknowledges that it has assented to all of the covenants and promises in this Agreement as a single whole and that all of such covenants and promises, taken as a whole, constitute the essence of the contract. Without limiting the generality of the foregoing, each of the Parties acknowledges that any provision by BellSouth of collocation space under this Agreement is solely for the purpose of facilitating the provision of other services under this Agreement and that neither Party would have contracted with respect to the provisioning of collocation space under this Agreement if the covenants and promises of the other Party with respect to the other services provided under this Agreement had not been made. The Parties further acknowledge that this Agreement is intended to constitute a single transaction, that the obligations of the Parties under this Agreement are interdependent, and that payment obligations under this Agreement are intended to be recouped against other payment obligations under this Agreement.

**17. Waivers**

A failure or delay of either Party to enforce any of the provisions hereof, to exercise any option which is herein provided, or to require performance of any of the provisions hereof shall in no way be construed to be a waiver of such provisions or options, and each Party, notwithstanding such failure, shall have the right thereafter to insist upon the performance of any and all of the provisions of this Agreement.

**18. Governing Law**

Where applicable, this Agreement shall be governed by and construed in accordance with federal and state substantive telecommunications law, including rules and regulations of the FCC and appropriate Commission. In all other respects, this Agreement shall be governed by and construed and enforced in accordance with the laws of the State of Georgia without regard to its conflict of laws principles.

**19. Assignments**

Any assignment by either Party to any non-affiliated entity of any right, obligation or duty, or of any other interest hereunder, in whole or in part, without the prior written consent of the other Party shall be void. A Party may assign this Agreement in its entirety to an Affiliate of the Party without the consent of the other Party; provided, however, that the assigning Party shall notify the other Party in writing of such assignment thirty (30) days prior to the Effective Date thereof and, provided further, if the assignee is an assignee of Clearwave Communications, the assignee must provide evidence of Commission CLEC certification. The Parties shall amend this Agreement to reflect such assignments and shall work cooperatively to implement any changes required due to such assignment. All

obligations and duties of any Party under this Agreement shall be binding on all successors in interest and assigns of such Party. No assignment or delegation hereof shall relieve the assignor of its obligations under this Agreement in the event that the assignee fails to perform such obligations. Notwithstanding anything to the contrary in this Section, Clearwave Communications shall not assign this Agreement to any Affiliate or non-affiliated entity unless either (1) Clearwave Communications pays all bills, past due and current, under this Agreement, or (2) Clearwave Communications's assignee expressly assumes liability for payment of such bills.

## **20. Notices**

20.1 Every notice, consent, approval, or other communications required or contemplated by this Agreement shall be in writing and shall be delivered by hand, by overnight courier or by US mail postage prepaid, address to:

### **BellSouth Telecommunications, Inc.**

BellSouth Local Contract Manager  
600 North 19<sup>th</sup> Street, 8<sup>th</sup> floor  
Birmingham, AL 35203

and

ICS Attorney  
Suite 4300  
675 West Peachtree Street  
Atlanta, GA 30375

### **Delta Communications, LLC d/b/a Clearwave Communications**

Scott Riggs  
President & CEO  
404 Seright Street  
Harrisburg, IL 62946  
Phone: 618-253-4174  
Fax: 618-253-3063  
e-mail: sriggs@clearwavecommunications.com

or at such other address as the intended recipient previously shall have designated by written notice to the other Party.

20.2 Unless otherwise provided in this Agreement, notice by mail shall be effective on the date it is officially recorded as delivered by return receipt or equivalent, and in the absence of such record of delivery, it shall be presumed to have been delivered the fifth day, or next business day after the fifth day, after it was deposited in the mails.

20.3 Notwithstanding the foregoing, BellSouth may provide Clearwave Communications notice via Internet posting of price changes and changes to the terms and conditions of services available for resale per Commission Orders. BellSouth will post changes to business processes and policies, notices of new service offerings, and changes to service offerings not requiring an amendment to this Agreement, notices required to be posted to BellSouth's website, and any other information of general applicability to CLECs.

**21. Rule of Construction**

No rule of construction requiring interpretation against the drafting Party hereof shall apply in the interpretation of this Agreement.

**22. Headings of No Force or Effect**

The headings of Articles and Sections of this Agreement are for convenience of reference only, and shall in no way define, modify or restrict the meaning or interpretation of the terms or provisions of this Agreement.

**23. Multiple Counterparts**

This Agreement may be executed in multiple counterparts, each of which shall be deemed an original, but all of which shall together constitute but one and the same document.

**24. Filing of Agreement**

Upon execution of this Agreement it shall be filed with the appropriate state regulatory agency pursuant to the requirements of Section 252 of the Act, and the Parties shall share equally any filing fees therefor. If the regulatory agency imposes any filing or public interest notice fees regarding the filing or approval of the Agreement, Clearwave Communications shall be responsible for publishing the required notice and the publication and/or notice costs shall be borne by Clearwave Communications. Notwithstanding the foregoing, this Agreement shall not be submitted for approval by the appropriate state regulatory agency unless and until such time as Clearwave Communications is duly certified as a local exchange carrier in such state, except as otherwise required by a Commission.

**25. Compliance with Applicable Law**

Each Party shall comply at its own expense with Applicable Law.

**26. Necessary Approvals**

Each Party shall be responsible for obtaining and keeping in effect all approvals from, and rights granted by, governmental authorities, building and property owners, other carriers, and any other persons that may be required in connection with the performance of its obligations under this Agreement. Each Party shall

reasonably cooperate with the other Party in obtaining and maintaining any required approvals and rights for which such Party is responsible.

**27. Good Faith Performance**

Each Party shall act in good faith in its performance under this Agreement and, in each case in which a Party's consent or agreement is required or requested hereunder, such Party shall not unreasonably withhold or delay such consent or agreement.

**28. Nonexclusive Dealings**

This Agreement does not prevent either Party from providing or purchasing services to or from any other person nor, except as provided in Section 252(i) of the Act, does it obligate either Party to provide or purchase any services (except insofar as the Parties are obligated to provide access to Interconnection, services and Network Elements to Clearwave Communications as a requesting carrier under the Act).

**29. Rate True-Up**

29.1 This section applies to Network Interconnection and/or Unbundled Network Elements and Other Services rates that are expressly subject to true-up under this Agreement.

29.2 The designated true-up rates shall be trued-up, either up or down, based on final prices determined either by further agreement between the Parties, or by a final order (including any appeals) of the Commission. The Parties shall implement the true-up by comparing the actual volumes and demand for each item, together with the designated true-up rates for each item, with the final prices determined for each item. Each Party shall keep its own records upon which the true-up can be based, and any final payment from one Party to the other shall be in an amount agreed upon by the Parties based on such records. In the event of any disagreement as between the records or the Parties regarding the amount of such true-up, the Parties shall submit the matter to the Dispute Resolution process in accordance with the provisions of Section 10 of the General Terms and Conditions of this Agreement.

29.3 An effective order of the Commission that forms the basis of a true-up shall be based upon cost studies submitted by either or both Parties to the Commission and shall be binding upon BellSouth and Clearwave Communications specifically or upon all carriers generally, such as a generic cost proceeding.

**30. Survival**

The Parties' obligations under this Agreement which by their nature are intended to continue beyond the termination or expiration of this Agreement shall survive

the termination or expiration of this Agreement.

**31. Entire Agreement**

31.1 This Agreement means the General Terms and Conditions, the Attachments identified in Section 31.2 below, and all documents identified therein, as such may be amended from time to time and which are incorporated herein by reference, all of which, when taken together, are intended to constitute one indivisible agreement. This Agreement sets forth the entire understanding and supersedes prior agreements between the Parties relating to the subject matter contained in this Agreement and merges all prior discussions between them. Any orders placed under prior agreements between the Parties shall be governed by the terms of this Agreement and Clearwave Communications acknowledges and agrees that any and all amounts and obligations owed for services provisioned or orders placed under prior agreements between the Parties, related to the subject matter hereof, shall be due and owing under this Agreement and be governed by the terms and conditions of this Agreement as if such services or orders were provisioned or placed under this Agreement. Neither Party shall be bound by any definition, condition, provision, representation, warranty, covenant or promise other than as expressly stated in this Agreement or as is contemporaneously or subsequently set forth in writing and executed by a duly authorized officer or representative of the Party to be bound thereby.

31.2 This Agreement includes Attachments with provisions for the following:

Resale  
Network Elements and Other Services  
Network Interconnection  
Collocation  
Access to Numbers and Number Portability  
Pre-Ordering, Ordering, Provisioning, Maintenance and Repair  
Billing  
Rights-of-Way, Conduits and Pole Attachments  
Performance Measurements  
BellSouth Disaster Recovery Plan  
Bona Fide Request/New Business Request Process

31.3 The following services are included as options for purchase by Clearwave Communications pursuant to the terms and conditions set forth in this Agreement. Clearwave Communications may elect to purchase said services by written request to its Local Contract Manager if applicable:

Optional Daily Usage File (ODUF)

Enhanced Optional Daily Usage File (EODUF)  
Access Daily Usage File (ADUF)  
Line Information Database (LIDB) Storage  
Centralized Message Distribution Service (CMDS)  
Calling Name (CNAM)  
LNP Data Base Query Service



IN WITNESS WHEREOF, the Parties have executed this Agreement the day and year written below.

**BellSouth Telecommunications, Inc.**

By:   
Name: Elizabeth R. A. Shireishi

Title: Director

Date: 7/2/03

**Delta Communications, LLC d/b/a  
Clearwave Communications**

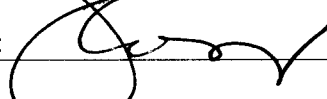
By:   
Name: Scott Riggs

Title: President & CEO

Date: 6/23/03

**Attachment 1**

**Resale**

**Table of Contents**

<b>1. Discount Rates.....</b>	<b>3</b>
<b>2. Definition of Terms.....</b>	<b>3</b>
<b>3. General Provisions .....</b>	<b>4</b>
<b>4. BellSouth’s Provision of Services to Clearwave Communications.....</b>	<b>8</b>
<b>5. Maintenance of Services .....</b>	<b>9</b>
<b>6. Establishment of Service .....</b>	<b>10</b>
<b>7. Discontinuance of Service.....</b>	<b>11</b>
<b>8. Operator Services (Operator Call Processing and Directory Assistance) .....</b>	<b>11</b>
<b>9. Line Information Database (LIDB).....</b>	<b>15</b>
<b>10. RAO Hosting .....</b>	<b>16</b>
<b>11. Optional Daily Usage File (ODUF).....</b>	<b>16</b>
<b>12. Enhanced Optional Daily Usage File (EODUF).....</b>	<b>16</b>
<b>Resale Restrictions</b>	<b>Exhibit A</b>
<b>Line Information Database (LIDB) Storage Agreement</b>	<b>Exhibit B</b>
<b>Optional Daily Usage File (ODUF)</b>	<b>Exhibit C</b>
<b>Enhanced Option Daily Usage File (EODUF)</b>	<b>Exhibit D</b>
<b>Resale Discounts and Rates</b>	<b>Exhibit E</b>

## **RESALE**

### **1. Discount Rates**

- 1.1 The discount rates applied to Clearwave Communications purchases of BellSouth Telecommunications Services for the purpose of resale shall be as set forth in Exhibit E. Such discounts have been determined by the applicable Commission to reflect the costs avoided by BellSouth when selling a service for wholesale purposes.
- 1.2 The telecommunications services available for purchase by Clearwave Communications for the purposes of resale to Clearwave Communications's End Users shall be available at BellSouth's tariffed rates less the discount set forth in Exhibit E to this Agreement and subject to the exclusions and limitations set forth in Exhibit A to this Agreement.

### **2. Definition of Terms**

- 2.1 **COMPETITIVE LOCAL EXCHANGE COMPANY (CLEC)** means a telephone company certificated by the Commission to provide local exchange service within BellSouth's franchised area.
- 2.2 **CUSTOMER OF RECORD** means the entity responsible for placing application for service; requesting additions, rearrangements, maintenance or discontinuance of service; payment in full of charges incurred such as non-recurring, monthly recurring, toll, directory assistance, etc.
- 2.3 **DEPOSIT** means assurance provided by a customer in the form of cash, surety bond or bank letter of credit to be held by BellSouth.
- 2.4 **END USER** means the ultimate user of the Telecommunications Service.
- 2.5 **END USER CUSTOMER LOCATION** means the physical location of the premises where an End User makes use of the telecommunications services.
- 2.6 **NEW SERVICES** means functions, features or capabilities that are not currently offered by BellSouth. This includes packaging of existing services or combining a new function, feature or capability with an existing service.
- 2.7 **RESALE** means an activity wherein a certificated CLEC, such as Clearwave Communications, subscribes to the telecommunications services of BellSouth and then offers those telecommunications services to the public.

### **3. General Provisions**

- 3.1 All of the negotiated rates, terms and conditions set forth in this Attachment pertain to the resale of BellSouth's retail telecommunications services and other services specified in this Attachment. Subject to effective and applicable FCC and Commission rules and orders, BellSouth shall make available to Clearwave Communications for resale those telecommunications services BellSouth makes available, pursuant to its General Subscriber Services Tariff and Private Line Services Tariff, to customers who are not telecommunications carriers.
- 3.1.1 When Clearwave Communications provides Resale service in a cross boundary area (areas that are part of the local serving area of another state's exchange) the rates, regulations and discounts for the tariffing state will apply. Billing will be from the serving state.
- 3.1.2 In Tennessee, if Clearwave Communications does not resell Lifeline service to any end users, and if Clearwave Communications agrees to order an appropriate Operator Services/Directory Assistance block as set forth in BellSouth's General Subscriber Services Tariff, the discount shall be 21.56%.
- 3.1.2.1 In the event Clearwave Communications resells Lifeline service to any end user in Tennessee, BellSouth will begin applying the 16% discount rate to all services. Upon Clearwave Communications and BellSouth's implementation of a billing arrangement whereby a separate Master Account (Q-account) associated with a separate Operating Customer Number (OCN) is established for billing of Lifeline service end users, the discount shall be applied as set forth in 3.1.2 preceding for the non-Lifeline affected Master Account (Q-account).
- 3.1.2.2 Clearwave Communications must provide written notification to BellSouth within 30 days prior to either providing its own operator services/ directory services or orders the appropriate operator services/directory assistance blocking, to qualify for the higher discount rate of 21.56%.
- 3.2 Clearwave Communications may purchase resale services from BellSouth for its own use in operating its business. The resale discount will apply to those services under the following conditions:
- 3.2.1 Clearwave Communications must resell services to other End Users.
- 3.2.2 Clearwave Communications cannot be a competitive local exchange telecommunications company for the single purpose of selling to itself.
- 3.3 Clearwave Communications will be the customer of record for all services purchased from BellSouth. Except as specified herein, BellSouth will take orders from, bill and receive payment from Clearwave Communications for said services.

- 3.4 Clearwave Communications will be BellSouth's single point of contact for all services purchased pursuant to this Agreement. BellSouth shall have no contact with the End User except to the extent provided for herein. Each Party shall provide to the other a nation wide (50 states) toll-free contact number for purposes of repair and maintenance.
- 3.5 BellSouth will continue to bill the End User for any services that the End User specifies it wishes to receive directly from BellSouth. BellSouth maintains the right to serve directly any End User within the service area of Clearwave Communications. BellSouth will continue to market directly its own telecommunications products and services and in doing so may establish independent relationships with End Users of Clearwave Communications. Neither Party shall interfere with the right of any person or entity to obtain service directly from the other Party.
- 3.5.1 When an End User of Clearwave Communications or BellSouth elects to change his/her carrier to the other Party, both Parties agree to release the End User's service to the other Party concurrent with the due date of the service order, which shall be established based on the standard interval for the End User's requested service as set forth in the BellSouth Product and Services Interval Guide.
- 3.5.2 BellSouth and Clearwave Communications will refrain from contacting an End User who has placed or whose selected carrier has placed on the End User's behalf an order to change the End User's service provider from BellSouth or Clearwave Communications to the other Party until such time that the order for service has been completed.
- 3.6 Current telephone numbers may normally be retained by the End User and are assigned to the service furnished. However, neither Party nor the End User has a property right to the telephone number or any other call number designation associated with services furnished by BellSouth, and no right to the continuance of service through any particular central office. BellSouth reserves the right to change such numbers, or the central office designation associated with such numbers, or both, whenever BellSouth deems it necessary to do so in the conduct of its business and in accordance with BellSouth practices and procedures on a nondiscriminatory basis.
- 3.7 Where BellSouth provides resold services to Clearwave Communications, BellSouth will provide Clearwave Communications with on-line access to intermediate telephone numbers as defined by applicable FCC rules and regulations on a first come first served basis. Clearwave Communications acknowledges that such access to numbers shall be in accordance with the appropriate FCC rules and regulations. Clearwave Communications acknowledges that there may be instances where there is a shortage of telephone numbers in a particular Common Language Location Identifier Code (CLLIC); and in such instances, Clearwave Communications shall return unused intermediate telephone numbers to BellSouth

upon BellSouth's request. BellSouth shall make all such requests on a nondiscriminatory basis.

- 3.8 BellSouth will allow Clearwave Communications to designate up to 100 intermediate telephone numbers per CLLIC, for Clearwave Communications's sole use. Assignment, reservation and use of telephone numbers shall be governed by applicable FCC rules and regulations. Clearwave Communications acknowledges that there may be instances where there is a shortage of telephone numbers in a particular CLLIC and BellSouth has the right to limit access to blocks of intermediate telephone numbers. These instances include: 1) where jeopardy status has been declared by the North American Numbering Plan (NANP) for a particular Numbering Plan Area (NPA); or 2) where a rate center has less than six months supply of numbering resources.
- 3.9 Service is furnished subject to the condition that it will not be used for any unlawful purpose.
- 3.10 Service will be discontinued if any law enforcement agency advises that the service being used is in violation of the law.
- 3.11 BellSouth can refuse service when it has grounds to believe that service will be used in violation of the law.
- 3.12 BellSouth will cooperate with law enforcement agencies with subpoenas and court orders relating to Clearwave Communications's End Users, pursuant to Section 6 of the General Terms and Conditions.
- 3.13 If Clearwave Communications or its End Users utilize a BellSouth resold telecommunications service in a manner other than that for which the service was originally intended as described in BellSouth's retail tariffs, Clearwave Communications has the responsibility to notify BellSouth. BellSouth will only provision and maintain said service consistent with the terms and conditions of the tariff describing said service.
- 3.14 Facilities and/or equipment utilized by BellSouth to provide service to Clearwave Communications remain the property of BellSouth.
- 3.15 White page directory listings for Clearwave Communications End Users will be provided in accordance with Section 5 of the General Terms and Conditions.
- 3.16 Service Ordering and Operational Support Systems (OSS)
- 3.16.1 Clearwave Communications must order services through resale interfaces, i.e., the Local Carrier Service Center (LCSC) and/or appropriate Complex Resale Support Group (CRSG) pursuant to this Agreement. BellSouth has developed and made available the interactive interfaces by which Clearwave Communications may submit a Local Service Request (LSR) electronically as set forth in Attachment 2

of this Agreement. Service orders will be in a standard format designated by BellSouth.

- 3.16.2 LSRs submitted by means of one of these interactive interfaces will incur an OSS electronic charge as set forth in Exhibit E to this Agreement. An individual LSR will be identified for billing purposes by its Purchase Order Number (PON). LSRs submitted by means other than one of these interactive interfaces (Mail, fax, courier, etc.) will incur a manual order charge as set forth in Exhibit E to this Agreement. Supplements or clarifications to a previously billed LSR will not incur another OSS charge.
- 3.16.3 Denial/Restoral OSS Charge. In the event Clearwave Communications provides a list of customers to be denied and restored, rather than an LSR, each location on the list will require a separate PON and therefore will be billed as one LSR per location.
- 3.16.4 Cancellation OSS Charge. Clearwave Communications will incur an OSS charge for an accepted LSR that is later canceled.
- 3.17 Where available to BellSouth's End Users, BellSouth shall provide the following telecommunications services at a discount to allow for voice mail services:
- Message Waiting Indicator ("MWI"), stutter dialtone and message waiting light feature capabilities
  - Call Forward Busy Line ("CF/B")
  - Call Forward Don't Answer ("CF/DA")
- Further, BellSouth messaging services set forth in BellSouth's Messaging Service Information Package shall be made available for resale without the wholesale discount.
- 3.18 BellSouth shall provide branding for, or shall unbrand, voice mail services for Clearwave Communications per the Bona Fide Request/New Business Request process as set forth in Attachment 6 of this Agreement.
- 3.19 BellSouth's Inside Wire Maintenance Service Plan is available for resale at rates, terms and conditions as set forth by BellSouth and without the wholesale discount.
- 3.20 In the event Clearwave Communications acquires an end user whose service is provided pursuant to a BellSouth Special Assembly, BellSouth shall make available to Clearwave Communications that Special Assembly at the wholesale discount at Clearwave Communications's option. Clearwave Communications shall be responsible for all terms and conditions of such Special Assembly including but not limited to termination liability if applicable.



- 3.21 BellSouth shall provide 911/E911 for Clearwave Communications customers in the same manner that it is provided to BellSouth customers. BellSouth shall provide and validate Clearwave Communications customer information to the PSAP. BellSouth shall use its service order process to update and maintain, on the same schedule that it uses for its customers, the Clearwave Communications customer service information in the ALI/DMS (Automatic Location Identification/Location Information) databases used to support 911/E911 services.
- 3.22 BellSouth shall bill, and Clearwave Communications shall pay, the End User line charge associated with implementing Number Portability as set forth in BellSouth's FCC No. 1 tariff. This charge is not subject to the wholesale discount.
- 3.23 Pursuant to 47 CFR Section 51.617, BellSouth shall bill to Clearwave Communications, and Clearwave Communications shall pay, the End User common line charges identical to the End User common line charges BellSouth bills its End Users.
- 4. BellSouth's Provision of Services to Clearwave Communications**
- 4.1 Resale of BellSouth services shall be as follows:
- 4.1.1 The resale of telecommunications services shall be limited to users and uses conforming to the class of service restrictions.
- 4.1.2 Hotel and Hospital PBX services are the only telecommunications services available for resale to Hotel/Motel and Hospital End Users, respectively. Similarly, Access Line Service for Customer Provided Coin Telephones is the only local service available for resale to Payphone Service Provider (PSP) customers. Shared Tenant Service customers can only be sold those local exchange access services available in BellSouth's A23 Shared Tenant Service Tariff in the states of Florida, Georgia, North Carolina and South Carolina, and in A27 in the states of Alabama, Kentucky, Louisiana, Mississippi and Tennessee.
- 4.1.3 BellSouth reserves the right to periodically audit services purchased by Clearwave Communications to establish authenticity of use. Such audit shall not occur more than once in a calendar year. Clearwave Communications shall make any and all records and data available to BellSouth or BellSouth's auditors on a reasonable basis. BellSouth shall bear the cost of said audit. Any information provided by Clearwave Communications for purposes of such audit shall be deemed Confidential Information pursuant to the General Terms and Conditions of this Agreement.
- 4.2 Subject to Exhibit A hereto, resold services can only be used in the same manner as specified in BellSouth's Tariffs. Resold services are subject to the same terms and conditions as are specified for such services when furnished to an individual End User of BellSouth in the appropriate section of BellSouth's Tariffs. Specific

tariff features (e.g. a usage allowance per month) shall not be aggregated across multiple resold services.

4.3 Clearwave Communications may resell services only within the specific service area as defined in its certificate of operation approved by the Commission.

4.4 If Clearwave Communications cancels an order for resold services, any costs incurred by BellSouth in conjunction with provisioning of such order will be recovered in accordance with BellSouth's General Subscriber Services Tariffs and Private Line Services Tariffs.

4.5 Service Jointly Provisioned with an Independent Company or Competitive Local Exchange Company Areas

4.5.1 BellSouth will in some instances provision resold services in accordance with the General Subscriber Services Tariff and Private Line Tariffs jointly with an Independent Company or other Competitive Local Exchange Carrier.

4.5.2 When Clearwave Communications assumes responsibility for such service, all terms and conditions defined in the Tariff will apply for services provided within the BellSouth service area only.

4.5.3 Service terminating in an Independent Company or other Competitive Local Exchange Carrier area will be provisioned and billed by the Independent Company or other Competitive Local Exchange Carrier directly to Clearwave Communications.

4.5.4 Clearwave Communications must establish a billing arrangement with the Independent Company or other Competitive Local Exchange Carrier prior to assuming an end user account where such circumstances apply.

4.5.5 Specific guidelines regarding such services are available on BellSouth's website @ [www.interconnection.bellsouth.com](http://www.interconnection.bellsouth.com).

**5. Maintenance of Services**

5.1 Services resold pursuant to this Attachment and BellSouth's General Subscriber Service Tariff and Private Line Service Tariff and facilities and equipment provided by BellSouth shall be maintained by BellSouth.

5.2 Clearwave Communications or its End Users may not rearrange, move, disconnect, remove or attempt to repair any facilities owned by BellSouth except with the written consent of BellSouth.

5.3 Clearwave Communications accepts responsibility to notify BellSouth of situations that arise that may result in a service problem.

- 5.4 Clearwave Communications will contact the appropriate repair centers in accordance with procedures established by BellSouth.
- 5.5 For all repair requests, Clearwave Communications shall adhere to BellSouth's prescreening guidelines prior to referring the trouble to BellSouth.
- 5.6 BellSouth will bill Clearwave Communications for handling troubles that are found not to be in BellSouth's network pursuant to its standard time and material charges. The standard time and material charges will be no more than what BellSouth charges to its retail customers for the same services.
- 5.7 BellSouth reserves the right to contact Clearwave Communications's End Users, if deemed necessary, for maintenance purposes.

## **6. Establishment of Service**

- 6.1 After receiving certification as a local exchange carrier from the applicable regulatory agency, Clearwave Communications will provide the appropriate BellSouth Advisory team manager the necessary documentation to enable BellSouth to establish accounts for resold services ("master account"). Clearwave Communications is required to provide the following before a master account is established: blanket letter of authorization, misdirected number form, proof of PSC/PUC certification, the Application for Master Account, an Operating Company Number ("OCN") assigned by the National Exchange Carriers Association ("NECA") and a deposit and tax exemption certificate, if applicable.
- 6.1.1 If Clearwave Communications needs to change its OCN(s) under which it operates when Clearwave Communications has already been conducting business utilizing those OCN(s), Clearwave Communications shall bear all costs incurred by BellSouth to convert Clearwave Communications Clearwave Communications to the new OCN(s). OCN conversion charges include all time required to make system updates to all of Clearwave Communications's end user customer records. Appropriate charges will appear in the OC&C section of Clearwave Communications's bill.
- 6.2 Clearwave Communications shall provide to BellSouth a blanket letter of authorization ("LOA") certifying that Clearwave Communications will have End User authorization prior to viewing the End User's customer service record or switching the End User's service. BellSouth will not require End User confirmation prior to establishing service for Clearwave Communications's End User customer.
- 6.3 BellSouth will accept a request directly from the End User for conversion of the End User's service from Clearwave Communications to BellSouth or will accept a request from another CLEC for conversion of the End User's service from Clearwave Communications to such other CLEC. Upon completion of the

conversion BellSouth will notify Clearwave Communications that such conversion has been completed.

## **7. Discontinuance of Service**

7.1 The procedures for discontinuing service to an End User are as follows:

7.1.1 BellSouth will deny service to Clearwave Communications's End User on behalf of, and at the request of, Clearwave Communications. Upon restoration of the End User's service, restoral charges will apply and will be the responsibility of Clearwave Communications.

7.1.2 At the request of Clearwave Communications, BellSouth will disconnect a Clearwave Communications End User customer.

7.1.3 All requests by Clearwave Communications for denial or disconnection of an End User for nonpayment must be in writing.

7.1.4 Clearwave Communications will be made solely responsible for notifying the End User of the proposed disconnection of the service.

7.1.5 BellSouth will continue to process calls made to the Annoyance Call Center and will advise Clearwave Communications when it is determined that annoyance calls are originated from one of its End User's locations. BellSouth shall be indemnified, defended and held harmless by Clearwave Communications and/or the End User against any claim, loss or damage arising from providing this information to Clearwave Communications. It is the responsibility of Clearwave Communications to take the corrective action necessary with its End Users who make annoying calls. (Failure to do so will result in BellSouth's disconnecting the End User's service.)

## **8. Operator Services (Operator Call Processing and Directory Assistance)**

8.1 Operator Call Processing provides: (1) operator handling for call completion (for example, collect, third number billing, and manual calling-card calls). (2) operator or automated assistance for billing after the end user has dialed the called number (for example, calling card calls); and (3) special services including but not limited to Busy Line Verification and Emergency Line Interrupt (ELI), Emergency Agency Call and Operator-assisted Directory Assistance.

8.1 Upon request for BellSouth Operator Call Processing, BellSouth shall:

8.1.1 . Process 0+ and 0- dialed local calls

8.1.3 .2 Process 0+ and 0- intraLATA toll calls.

- 8.1.4 Process calls that are billed to Clearwave Communications end user's calling card that can be validated by BellSouth.
- 8.1.5 Process person-to-person calls.
- 8.1.6 Process collect calls.
- 8.1.7 Provide the capability for callers to bill a third party and shall also process such calls.
- 8.1.8 Process station-to-station calls.
- 8.1.9 Process Busy Line Verify and Emergency Line Interrupt requests.
- 8.1.10 Process emergency call trace originated by Public Safety Answering Points.
- 8.1.11 Process operator-assisted directory assistance calls.
- 8.1.12 Adhere to equal access requirements, providing Clearwave Communications local end users the same IXC access that BellSouth provides its own operator service.
- 8.1.13 Exercise at least the same level of fraud control in providing Operator Service to Clearwave Communications that BellSouth provides for its own operator service.
- 8.1.14 Perform Billed Number Screening when handling Collect, Person-to-Person, and Billed-To-Third-Party calls.
- 8.1.15 Direct customer account and other similar inquiries to the customer service center designated by Clearwave Communications.
- 8.1.16 Provide call records to Clearwave Communications in accordance with ODUF standards.
- 8.1.17 The interface requirements shall conform to the interface specifications for the platform used to provide Operator Services as long as the interface conforms to industry standards.
- 8.2 Directory Assistance Service
  - 8.2.1 Directory Assistance Service provides local and non-local end user telephone number listings with the option to complete the call at the caller's direction separate and distinct from local switching.
  - 8.2.2 Directory Assistance Service shall provide up to two listing requests per call, if available and if requested by Clearwave Communications's end user. BellSouth shall provide caller-optional directory assistance call completion service at rates set forth in BellSouth's General Subscriber Services Tariff to one of the provided listings.

### 8.3.1 Directory Assistance Service Updates

8.3.1 BellSouth shall update end user listings changes daily. These changes include:

8.3.2 New end user connections

8.3.3 End user disconnections

8.3.4 End user address changes

8.3.5 These updates shall also be provided for non-listed and non-published numbers for use in emergencies.

### 8.4 Branding for Operator Call Processing and Directory Assistance

8.4.1 BellSouth's branding feature provides a definable announcement to Clearwave Communications end users using Directory Assistance (DA)/ Operator Call Processing (OCP) prior to placing such end users in queue or connecting them to an available operator or automated operator system. This feature allows Clearwave Communications's name on whose behalf BellSouth is providing Directory Assistance and/or Operator Call Processing. Rates for the branding features are set forth in Exhibit E of this Attachment.

8.4.2 BellSouth offers three branding offering options to Clearwave Communications when ordering BellSouth's Directory Assistance and Operator Call Processing: BellSouth Branding, Unbranding and Custom Branding.

8.4.3 Upon receipt of the branding order from Clearwave Communications, the order is considered firm after ten (10) business days. Should Clearwave Communications decide to cancel the order, written notification to Clearwave Communications's BellSouth Account Executive is required. If Clearwave Communications decides to cancel after ten (10) business days from receipt of the branding order, Clearwave Communications shall pay all charges per the order.

#### 8.4.4 Branding via Originating Line Number Screening (OLNS)

8.4.4.1 BellSouth Branding, Unbranding and Custom Branding are also available for Directory Assistance, Operator Call Processing or both via OLNS software. When utilizing this method of Unbranding or Custom Branding Clearwave Communications shall not be required to purchase dedicated trunking.

8.4.4.2 BellSouth Branding is the default branding offering.

8.4.4.3 For BellSouth to provide Unbranding or Custom Branding via OLNS software for Operator Call Processing or for Directory Assistance Clearwave Communications must have its Operating Company Number ("OCN(s)") and telephone numbers reside in BellSouth's LIDB; however, a BellSouth LIDB Storage Agreement is not

required. To Implement Unbranding and Custom Branding via OLNS software, Clearwave Communications must submit a manual order form which requires, among other things, Clearwave Communications's OCN and a forecast for the traffic volume anticipated for each BellSouth TOPS during the peak busy hour. Clearwave Communications shall provide updates to such forecast on a quarterly basis and at any time such forecasted traffic volumes are expected to change significantly. Upon Clearwave Communications's purchase of Unbranding and Custom Branding using OLNS software for any particular TOPS, all Clearwave Communications end users served by that TOPS will receive the Unbranded "no announcement" or the Custom Branded announcement.

8.4.4.4 Rates for Unbranding and Custom Branding via OLNS software for Directory Assistance and for Operator Call Processing are as set forth in Exhibit E of this Attachment. In addition to the charges for Unbranding and Custom Branding via OLNS software, Clearwave Communications shall continue to pay BellSouth applicable labor and other charges for the use of BellSouth's Directory Assistance and Call Processing platforms as set forth in Exhibit E of this Attachment.

8.4.5 Selective Call Routing using Line Class Codes (SCR-LCC)

8.4.5.1 Where Clearwave Communications resells BellSouth's services and utilizes an operator services provider other than BellSouth, BellSouth will route Clearwave Communications's end user calls to that provider through Selective Call Routing.

8.4.5.2 Selective Call Routing using Line Class Codes (SCR-LCC) provides the capability for Clearwave Communications to have its OCP/DA calls routed to BellSouth's OCP/DA platform for BellSouth provided Custom Branded or Unbranded OCP/DA or to its own or an alternate OCP/DA platform for Self-Branded OCP/DA. SCR-LCC is only available if line class code capacity is available in the requested BellSouth end office switches.

8.4.5.3 Custom Branding for Directory Assistance is not available for certain classes of service, including but not limited to Hotel/Motel services, WATS service and certain PBX services.

8.4.5.4 Where available, Clearwave Communications specific and unique line class codes are programmed in each BellSouth end office switch where Clearwave Communications intends to service end users with customized OCP/DA branding. The line class codes specifically identify Clearwave Communications's end users so OCP/DA calls can be routed over the appropriate trunk group to the requested OCP/DA platform. Additional line class codes are required in each end office if the end office serves multiple NPAs (i.e., a unique LCC is required per NPA), and/or if the end office switch serves multiple rate areas and Clearwave Communications intends to provide Clearwave Communications-branded OCP/DA to its end users in these multiple rate areas.

- 8.4.5.5 BellSouth Branding is the default branding offering.
- 8.4.5.6 SCR-LCC supporting Custom Branding and Self Branding require Clearwave Communications to order dedicated transport and trunking from each BellSouth end office identified by Clearwave Communications, either to the BellSouth Traffic Operator Position System (TOPS) for Custom Branding or to the Clearwave Communications Operator Service Provider for Self Branding. Separate trunk groups are required for Operator Services and for Directory Assistance. Rates for transport and trunks are set forth in applicable BellSouth Tariffs.
- 8.4.5.7 The rates for SCR-LCC are as set forth in Exhibit E of this Attachment. There is a nonrecurring charge for the establishment of each Line Class Code in each BellSouth central office.
- 8.4.5.8 Unbranded Directory Assistance and/or Operator Call Processing calls ride common trunk groups provisioned by BellSouth from those end offices identified by Clearwave Communications to the BellSouth Tops. The calls are routed to "No Announcement."
- 8.4.6 Customized Branding includes charges for the recording of the branding announcement and the loading of the audio units in each TOPS Switch and Network Applications Vehicle (NAV) equipment for which Clearwave Communications requires service.
- 8.4.6.1 Directory Assistance customized branding uses:
- 8.4.6.2 the recording of Clearwave Communications
- 8.4.6.3 the loading of the recording in each switch.
- 8.4.6.4 Operator Call Processing customized branding uses:
- 8.4.6.5 the recording of Clearwave Communications
- 8.4.6.6 2 the loading of the recording in each switch.
- 8.4.6.7 the loading on the Network Applications Vehicle (NAV). All NAV shelves within the region where the customer is offering service must be loaded.

## **9. Line Information Database (LIDB)**

- 9.1 BellSouth will store in its Line Information Database (LIDB) records relating to service only in the BellSouth region. The LIDB Storage Agreement is included in this Attachment as Exhibit B.
- 9.2 BellSouth will provide LIDB Storage upon written request to Clearwave Communications's Account Manager stating a requested activation date.



**10. RAO Hosting**

10.1 RAO Hosting is not required for resale in the BellSouth region.

**11. Optional Daily Usage File (ODUF)**

11.1 The Optional Daily Usage File (ODUF) Agreement with terms and conditions is included in this Attachment as Exhibit C. Rates for ODUF are as set forth in Exhibit E of this Attachment.

11.2. BellSouth will provide ODUF service upon written request to its Account Manager stating a requested activation date.

**12. Enhanced Optional Daily Usage File (EODUF)**

12.1 The Enhanced Optional Daily Usage File (EODUF) service Agreement with terms and conditions is included in this Attachment as Exhibit D. Rates for EODUF are as set forth in Exhibit E of this Attachment.

12.2 BellSouth will provide EODUF service upon written request to its Account Manager stating a requested activation date.

**EXCLUSIONS AND LIMITATIONS ON SERVICES AVAILABLE FOR RESALE (Note 3)**

Type of Service	AL		FL		GA		KY		LA		MS		NC		SC		TN	
	Resale	Discount	Resale	Discount	Resale	Discount	Resale	Discount	Resale	Discount	Resale	Discount	Resale	Discount	Resale	Discount	Resale	Discount
1 Grandfathered Services (Note 1)	Yes	Yes	Yes	Yes	Yes	Yes	Yes	Yes	Yes	Yes	Yes	Yes	Yes	Yes	Yes	Yes	Yes	Yes
2 Promotions - > 90 Days(Note 2)	Yes	Yes	Yes	Yes	Yes	Yes	Yes	Yes	Yes	Yes	Yes	Yes	Yes	Yes	Yes	Yes	Yes	Yes
3 Promotions - ≤ 90 Days (Note 2)	Yes	No	Yes	No	Yes	No	Yes	No	Yes	No	Yes	No	Yes	No	Yes	No	Yes	No
4 Lifeline/Link Up Services	Yes	Yes	Yes	Yes	Yes	Yes	No	No	Yes	Yes	Yes	Yes	Yes	Yes	Yes	Yes	Yes	Yes
5 911/E911 Services	Yes	Yes	Yes	Yes	Yes	Yes	Yes	Yes	No	No	Yes	Yes	Yes	Yes	Yes	Yes	Yes	Yes
6 N11 Services	Yes	Yes	Yes	Yes	Yes	Yes	No	No	No	No	Yes	Yes	Yes	Yes	No	No	Yes	Yes
7 MemoryCall® Service	Yes	No	Yes	No	Yes	No	Yes	No	Yes	No	Yes	No	Yes	No	Yes	No	Yes	No
8 Mobile Services	Yes	No	Yes	No	Yes	No	Yes	No	Yes	No	Yes	No	Yes	No	Yes	No	Yes	No
9 Federal Subscriber Line Charges	Yes	No	Yes	No	Yes	No	Yes	No	Yes	No	Yes	No	Yes	No	Yes	No	Yes	No
10 Non-RecurCharges	Yes	Yes	Yes	Yes	Yes	Yes	Yes	Yes	Yes	Yes	Yes	Yes	Yes	Yes	Yes	Yes	Yes	No
11 End User Line Chg-Number Portability	Yes	No	Yes	No	Yes	No	Yes	No	Yes	No	Yes	No	Yes	No	Yes	No	Yes	No
12 Public Telephone Access Svc(PTAS)	Yes	Yes	Yes	Yes	Yes	Yes	Yes	Yes	Yes	Yes	Yes	Yes	Yes	Yes	Yes	No	Yes	Yes
13 Inside Wire Maint Service Plan	Yes	No	Yes	No	Yes	No	Yes	No	Yes	No	Yes	No	Yes	No	Yes	No	Yes	No
<b>Applicable Notes:</b>																		
1.	<b>Grandfathered services</b> can be resold only to existing subscribers of the grandfathered service.																	
2.	Where available for resale, <b>promotions</b> will be made available only to End Users who would have qualified for the promotion had it been provided by BellSouth directly.																	
3.	Some of BellSouth's local exchange and toll telecommunications services are not available in certain central offices and areas.																	

## LINE INFORMATION DATA BASE (LIDB)

### RESALE STORAGE AGREEMENT

#### **I. Definitions (from Addendum)**

- A. Billing number - a number used by BellSouth for the purpose of identifying an account liable for charges. This number may be a line or a special billing number.
- B. Line number - a ten-digit number assigned by BellSouth that identifies a telephone line associated with a resold local exchange service.
- C. Special billing number - a ten-digit number that identifies a billing account established by BellSouth in connection with a resold local exchange service.
- D. Calling Card number - a billing number plus PIN number assigned by BellSouth.
- E. PIN number - a four-digit security code assigned by BellSouth that is added to a billing number to compose a fourteen-digit calling card number.
- F. Toll billing exception indicator - associated with a billing number to indicate that it is considered invalid for billing of collect calls or third number calls or both, by Clearwave Communications.
- G. Billed Number Screening - refers to the query service used to determine whether a toll billing exception indicator is present for a particular billing number.
- H. Calling Card Validation - refers to the query service used to determine whether a particular calling card number exists as stated or otherwise provided by a caller.
- I. Billing number information - information about billing number or Calling Card number as assigned by BellSouth and toll billing exception indicator provided to BellSouth by Clearwave Communications.
- J. Get-Data - refers to the query service used to determine, at a minimum, the Account Owner and/or Regional Accounting Office for a line number. This query service may be modified to provide additional information in the future.
- K. Originating Line Number Screening ("OLNS") - refers to the query service used to determine the billing, screening and call handling indicators, station type and Account Owner provided to BellSouth by Clearwave Communications for originating line numbers.

- L. Account Owner - name of the local exchange telecommunications company that is providing dialtone on a subscriber line.

## **II. General**

- A. This Agreement sets forth the terms and conditions pursuant to which BellSouth agrees to store in its LIDB certain information at the request of Clearwave Communications and pursuant to which BellSouth, its LIDB customers and Clearwave Communications shall have access to such information. In addition, this Agreement sets forth the terms and conditions for Clearwave Communications's provision of billing number information to BellSouth for inclusion in BellSouth's LIDB. Clearwave Communications understands that BellSouth provides access to information in its LIDB to various telecommunications service providers pursuant to applicable tariffs and agrees that information stored at the request of Clearwave Communications, pursuant to this Agreement, shall be available to those telecommunications service providers. The terms and conditions contained herein shall hereby be made a part of this Resale Agreement upon notice to Clearwave Communications's account team and/or Local Contract Manager activate this LIDB Storage Agreement. The General Terms and Conditions of the Resale Agreement shall govern this LIDB Storage Agreement. The terms and conditions contained in the attached Addendum are hereby made a part of this LIDB Storage Agreement as if fully incorporated herein.

- B. BellSouth will provide responses to on-line, call-by-call queries to billing number information for the following purposes:

- 1. Billed Number Screening

BellSouth is authorized to use the billing number information to determine whether Clearwave Communications has identified the billing number as one that should not be billed for collect or third number calls.

- 2. Calling Card Validation

BellSouth is authorized to validate a 14-digit Calling Card number where the first 10 digits are a line number or special billing number assigned by BellSouth, and where the last four digits (PIN) are a security code assigned by BellSouth.

- 3. OLNS

BellSouth is authorized to provide originating line screening information for billing services restrictions, station type, call handling indicators, presubscribed interLATA and local carrier and account owner on the lines of Clearwave Communications from which a call originates.

#### 4. GetData

BellSouth is authorized to provide, at a minimum, the account owner and/or Regional Accounting Office information on the lines of Clearwave Communications indicating the local service provider and where billing records are to be sent for settlement purposes. This query service may be modified to provide additional information in the future.

#### 5. Fraud Control

BellSouth will provide seven days per week, 24-hours per day, fraud monitoring on Calling Cards, bill-to-third and collect calls made to numbers in BellSouth's LIDB, provided that such information is included in the LIDB query. BellSouth will establish fraud alert thresholds and will notify Clearwave Communications of fraud alerts so that Clearwave Communications may take action it deems appropriate.

### **III. Responsibilities of the Parties**

A. BellSouth will administer all data stored in the LIDB, including the data provided by Clearwave Communications pursuant to this Agreement, in the same manner as BellSouth's data for BellSouth's End User customers. BellSouth shall not be responsible to Clearwave Communications for any lost revenue which may result from BellSouth's administration of the LIDB pursuant to its established practices and procedures as they exist and as they may be changed by BellSouth in its sole discretion from time to time.

#### B. Billing and Collection Customers

BellSouth currently has in effect numerous billing and collection agreements with various interexchange carriers and billing clearing houses and as such these billing and collection customers ("B&C Customers") query BellSouth's LIDB to determine whether to accept various billing options from End Users. Until such time as BellSouth implements in its LIDB and its supporting systems the means to differentiate Clearwave Communications's data from BellSouth's data, the following shall apply:

- (1) BellSouth will identify Clearwave Communications end user originated long distance charges and will return those charges to the interexchange carrier as not covered by the existing B&C agreement. Clearwave Communications is responsible for entering into the appropriate agreement with interexchange carriers for handling of long distance charges by their end users.
- (2) BellSouth shall have no obligation to become involved in any disputes between Clearwave Communications and B&C Customers. BellSouth will not issue adjustments for charges billed on behalf of any B&C Customer to Clearwave

Communications. It shall be the responsibility of Clearwave Communications and the B&C Customers to negotiate and arrange for any appropriate adjustments.

**IV. Fees for Service and Taxes**

- A. Clearwave Communications will not be charged a fee for storage services provided by BellSouth to Clearwave Communications, as described in this LIDB Resale Storage Agreement.
- B. Sales, use and all other taxes (excluding taxes on BellSouth's income) determined by BellSouth or any taxing authority to be due to any federal, state or local taxing jurisdiction with respect to the provision of the service set forth herein will be paid by Clearwave Communications in accordance with the tax provisions set forth in the General Terms and Conditions of this Agreement.

**Optional Daily Usage File**

1. Upon written request from Clearwave Communications, BellSouth will provide the Optional Daily Usage File (ODUF) service to Clearwave Communications pursuant to the terms and conditions set forth in this section.
2. Clearwave Communications shall furnish all relevant information required by BellSouth for the provision of the ODUF.
3. The ODUF feed will contain billable messages that were carried over the BellSouth Network and processed in the BellSouth Billing System, but billed to a Clearwave Communications customer.
4. Charges for ODUF will appear on Clearwave Communications's monthly bills. The charges are as set forth in Exhibit E to this Attachment. ODUF charges are billed once a month for the previous month's usage. Clearwave Communications will be billed at the ODUF rates that are in effect at the end of the previous month.
5. The ODUF feed will contain both rated and unrated messages. All messages will be in the standard Alliance for Telecommunications Industry Solutions (ATIS) EMI record format.
- 5.1 Messages that error in Clearwave Communications's billing system will be the responsibility of Clearwave Communications. If, however, Clearwave Communications should encounter significant volumes of errored messages that prevent processing by Clearwave Communications within its systems, BellSouth will work with Clearwave Communications to determine the source of the errors and the appropriate resolution.
6. The following specifications shall apply to the ODUF feed.
  - 6.1 ODUF Message to be Transmitted
    - 6.1.1 The following messages recorded by BellSouth will be transmitted to Clearwave Communications:
      - Message recording for per use/per activation type services (examples: Three Way Calling, Verify, Interrupt, Call Return, etc.)
      - Measured billable Local
      - Directory Assistance messages
      - IntraLATA Toll

- WATS and 800 Service
  - N11
  - Information Service Provider Messages
  - Operator Services Messages
  - Credit/Cancel Records
  - Usage for Voice Mail Message Service
- 6.1.2 Rated Incollects (originated in BellSouth and from other companies) can also be on ODUF. Rated Incollects will be intermingled with BellSouth recorded rated and unrated usage. Rated Incollects will not be packed separately.
- 6.1.3 BellSouth will perform duplicate record checks on records processed to ODUF. Any duplicate messages detected will be deleted and not sent to Clearwave Communications.
- 6.1.4 In the event that Clearwave Communications detects a duplicate on ODUF they receive from BellSouth, Clearwave Communications will drop the duplicate message and will not return the duplicate to BellSouth).
- 6.2 ODUF Physical File Characteristics
- 6.2.1 The ODUF will be distributed to Clearwave Communications via CONNECT:Direct or Secure File Transfer Protocol (FTP) or another mutually agreed medium. The ODUF feed will be a variable block format. The data on the ODUF feed will be in a non-compacted EMI format (175 byte format plus modules). It will be created on a daily basis Monday through Friday except holidays. Details such as dataset name and delivery schedule will be addressed during negotiations of the distribution medium. There will be a maximum of one dataset per workday per OCN.
- 6.2.2 Data circuits (private line or dial-up) will be required between BellSouth and Clearwave Communications for the purpose of data transmission when utilizing CONNECT:Direct. Where a dedicated line is required, Clearwave Communications will be responsible for ordering the circuit, overseeing its installation and coordinating the installation with BellSouth. Clearwave Communications will also be responsible for any charges associated with this line. Equipment required on the BellSouth end to attach the line to the mainframe computer and to transmit data will be negotiated on an individual case basis. Where a dial-up facility is required, dial circuits will be installed in the BellSouth data center by BellSouth and the associated charges assessed to Clearwave Communications. Additionally, all message toll charges associated with the



use of the dial circuit by Clearwave Communications will be the responsibility of Clearwave Communications. Associated equipment on the BellSouth end, including a modem, will be negotiated on an individual case basis between the Parties. All equipment, including modems and software, that is required on Clearwave Communications end for the purpose of data transmission will be the responsibility of Clearwave Communications.

- 6.2.3 If Clearwave Communications utilizes Secure File Transfer Protocol (FTP) for data file transmission, purchase of the Secure File Transfer Protocol (FTP) software will be the responsibility of Clearwave Communications.

6.3 ODUF Packing Specifications

- 6.3.1 A pack will contain a minimum of one message record or a maximum of 99,999 message records plus a pack header record and a pack trailer record. One transmission can contain a maximum of 99 packs and a minimum of one pack.

- 6.3.2 The OCN, From RAO, and Invoice Number will control the invoice sequencing. The From RAO will be used to identify to Clearwave Communications which BellSouth RAO is sending the message. BellSouth and Clearwave Communications will use the invoice sequencing to control data exchange. BellSouth will be notified of sequence failures identified by Clearwave Communications and resend the data as appropriate.

The data will be packed using ATIS EMI records.

6.4 ODUF Pack Rejection

- 6.4.1 Clearwave Communications will notify BellSouth within one business day of rejected packs (via the mutually agreed medium). Packs could be rejected because of pack sequencing discrepancies or a critical edit failure on the Pack Header or Pack Trailer records (i.e. out-of-balance condition on grand totals, invalid data populated). Standard ATIS EMI Error Codes will be used. Clearwave Communications will not be required to return the actual rejected data to BellSouth. Rejected packs will be corrected and retransmitted to Clearwave Communications by BellSouth.

6.5 ODUF Control Data

Clearwave Communications will send one confirmation record per pack that is received from BellSouth. This confirmation record will indicate Clearwave Communications received the pack and the acceptance or rejection of the pack. Pack Status Code(s) will be populated using standard ATIS EMI error codes for packs that were rejected by Clearwave Communications for reasons stated in the above section.

## 6.6 ODUF Testing

- 6.6.1 Upon request from Clearwave Communications, BellSouth shall send test files to Clearwave Communications for the ODUF. The Parties agree to review and discuss the file's content and/or format. For testing of usage results, BellSouth shall request that Clearwave Communications set up a production (live) file. The live test may consist of Clearwave Communications's employees making test calls for the types of services Clearwave Communications requests on the ODUF. These test calls are logged by Clearwave Communications, and the logs are provided to BellSouth. These logs will be used to verify the files. Testing will be completed within 30 calendar days from the date on which the initial test file was sent.

**Enhanced Optional Daily Usage File**

1. Upon written request from Clearwave Communications, BellSouth will provide the Enhanced Optional Daily Usage File (EODUF) service to Clearwave Communications pursuant to the terms and conditions set forth in this section. EODUF will only be sent to existing ODUF subscribers who request the EODUF option.
2. Clearwave Communications shall furnish all relevant information required by BellSouth for the provision of the EODUF.
3. The EODUF will provide usage data for local calls originating from resold Flat Rate Business and Residential Lines.
4. Charges for delivery of the EODUF will appear on Clearwave Communications's monthly bills. EODUF charges are billed at the EODUF rates that are in effect at the end of the previous month. The charges are as set forth in Exhibit E to this Attachment.
5. All messages will be in the standard Alliance for Telecommunications Industry Solutions (ATIS) EMI record format.
6. Messages that error in the billing system of Clearwave Communications will be the responsibility of Clearwave Communications. If, however, Clearwave Communications should encounter significant volumes of errored messages that prevent processing by Clearwave Communications within its systems, BellSouth will work with Clearwave Communications to determine the source of the errors and the appropriate resolution.
7. The following specifications shall apply to the EODUF feed.
  - 7.1 **Usage To Be Transmitted**
    - 7.1.1 The following messages recorded by BellSouth will be transmitted to Clearwave Communications:

Customer usage data for flat rated local call originating from Clearwave Communications's End User lines (1FB or 1FR). The EODUF record for flat rate messages will include:

Date of Call

From Number

To Number

Connect Time

Conversation Time

Method of Recording

From RAO

Rate Class

Message Type

Billing Indicators

Bill to Number

7.1.2 BellSouth will perform duplicate record checks on EODUF records processed to O DUF. Any duplicate messages detected will be deleted and not sent to Clearwave Communications.

7.1.3 In the event that Clearwave Communications detects a duplicate on EODUF they receive from BellSouth, Clearwave Communications will drop the duplicate message (Clearwave Communications will not return the duplicate to BellSouth).

## 7.2 Physical File Characteristics

7.2.1 The EODUF feed will be distributed to Clearwave Communications via Connect: Direct, Secure File Transfer Protocol (FTP) or another mutually agreed medium. The EODUF messages will be intermingled among Clearwave Communications's Optional Daily Usage File (ODUF) messages. The EODUF will be a variable block format. The data on the EODUF will be in a non-compacted EMI format (175 byte format plus modules). It will be created on a daily basis Monday through Friday except holiday.

7.2.2 Data circuits (private line or dial-up) may be required between BellSouth and Clearwave Communications for the purpose of data transmission as set forth in Section 6.2.2 above.

7.2.3 If Clearwave Communications utilizes Secure File Transfer Protocol (FTP) for data file transmission, purchase of the Secure File Transfer Protocol (FTP) software will be the responsibility of Clearwave Communications.

7.3 Packing Specifications

7.3.1 A pack will contain a minimum of one message record or a maximum of 99,999 message records plus a pack header record and a pack trailer record. One transmission can contain a maximum of 99 packs and a minimum of one pack.

7.3.2 The OCN, From (RAO), and Invoice Number will control the invoice sequencing. The From RAO will be used to identify to Clearwave Communications which BellSouth RAO is sending the message. BellSouth and Clearwave Communications will use the invoice sequencing to control data exchange. BellSouth will be notified of sequence failures identified by Clearwave Communications and resend the data as appropriate.

The data will be packed using ATIS EMI Records.

RESALE DISCOUNTS AND RATES - Kentucky										Attachment: 1		Exhibit: E				
CATEGORY	RATE ELEMENTS	Interim	Zone	BCS	USOC	RATES(\$)				Svc Order Submitted Elec per LSR	Svc Order Submitted Manually per LSR	Incremental Charge - Manual Svc Order vs. Electronic-1st	Incremental Charge - Manual Svc Order vs. Electronic-Add'l	Incremental Charge - Manual Svc Order vs. Electronic-Disc 1st	Incremental Charge - Manual Svc Order vs. Electronic-Disc Add'l	
						Rec	Nonrecurring		Nonrecurring Disconnect							OSS Rates(\$)
							First	Add'l	First	Add'l	SOME C	SOMAN	SOMAN	SOMAN	SOMAN	SOMAN
<b>APPLICABLE DISCOUNTS</b>																
	Residence %					16.79										
	Business %					15.54										
	CSAs %					15.54										
<b>OPERATIONAL SUPPORT SYSTEMS (OSS) RATES</b>																
	Electronic LSR				SOME C		3.50	3.50	3.50	3.50						
	Manual LSR				SOMAN		19.99	19.99	19.99	19.99						
<b>SELECTIVE CALL ROUTING USING LINE CLASS CODES (SCR-LCC)</b>																
	Selective Routing Per Unique Line Class Code Per Request Per Switch						93.53	93.53	15.58	15.58						
<b>DIRECTORY ASSISTANCE CUSTOM BRANDING ANNOUNCEMENT via OLNS SOFTWARE</b>																
	Recording of DA Custom Branded Announcement						3,000.00	3,000.00								
	Loading of DA Custom Branded Announcement per Switch per OCN						1,170.00	1,170.00								
<b>DIRECTORY ASSISTANCE UNBRANDING via OLNS SOFTWARE</b>																
	Loading of DA per OCN (1 OCN per Order)						420.00	420.00								
	Loading of DA per Switch per OCN						16.00	16.00								
<b>OPERATOR ASSISTANCE CUSTOM BRANDING ANNOUNCEMENT via OLNS SOFTWARE</b>																
	Recording of Custom Branded OA Announcement						7,000.00	7,000.00								
	Loading of Custom Branded OA Announcement per shelf/NAV per OCN						500.00	500.00								
	Loading of OA Custom Branded Announcement per Switch per OCN						1,170.00	1,170.00								
<b>OPERATOR ASSISTANCE UNBRANDING via OLNS SOFTWARE</b>																
	Loading of OA per OCN (Regional)						1,200.00	1,200.00								
<b>ODUF/EODUF SERVICES</b>																
<b>OPTIONAL DAILY USAGE FILE (ODUF)</b>																
	ODUF: Recording, per message						0.0000136									
	ODUF: Message Processing, per message						0.002506									
	ODUF: Message Processing, per Magnetic Tape provisioned						35.90									
	ODUF: Data Transmission (CONNECT:DIRECT), per message						0.00010372									
<b>ENHANCED OPTIONAL DAILY USAGE FILE (EODUF)</b>																
	EODUF: Message Processing, per message						0.235889									

## **Attachment 2**

### **Network Elements and Other Services**

**TABLE OF CONTENTS**

**1 INTRODUCTION..... 3**

**2 UNBUNDLED LOOPS..... 4**

**3 HIGH FREQUENCY SPECTRUM NETWORK ELEMENT..... 26**

**4 LOCAL SWITCHING..... 37**

**5 UNBUNDLED NETWORK ELEMENT COMBINATIONS..... 44**

**6 TRANSPORT, CHANNELIZATION AND DARK FIBER..... 51**

**7 BELLSOUTH SWITCHED ACCESS (SWA) 8XX TOLL FREE DIALING TEN DIGIT SCREENING SERVICE ..... 55**

**8 LINE INFORMATION DATABASE (LIDB)..... 56**

**9 SIGNALING ..... 59**

**10 OPERATOR SERVICES (OPERATOR CALL PROCESSING AND DIRECTORY ASSISTANCE) . 65**

**11 AUTOMATIC LOCATION IDENTIFICATION/DATA MANAGEMENT SYSTEM (ALI/DMS)..... 71**

**12 CALLING NAME (CNAM) DATABASE SERVICE..... 71**

**13 SERVICE CREATION ENVIRONMENT AND SERVICE MANAGEMENT SYSTEM (SCE/SMS) ADVANCED INTELLIGENT NETWORK (AIN) ACCESS ..... 73**

**14 BASIC 911 AND E911 ..... 73**

**15 OPERATIONAL SUPPORT SYSTEMS (OSS)..... 74**

**LIDB Storage Agreement ..... Exhibit A**

**Rates ..... Exhibit B**



## ACCESS TO NETWORK ELEMENTS AND OTHER SERVICES

### 1 Introduction

- 1.1 This Attachment sets forth rates, terms and conditions for Network Elements and combinations of Network Elements that BellSouth agrees to offer to Clearwave Communications in accordance with its obligations under Section 251(c)(3) of the Act. Additionally, this Attachment sets forth the rates, terms and conditions for other services BellSouth makes available to Clearwave Communications. The rates for each Network Element and combination of Network Elements and other services are set forth in Exhibit B of this Agreement. Additionally, the provision of a particular Network Element or service may require Clearwave Communications to purchase other Network Elements or services.
- 1.2 For purposes of this Agreement, “Network Element” is defined to mean a facility or equipment Clearwave Communications used in the provision of a telecommunications service. For purposes of this Agreement, combinations of Network Elements shall be referred to as “Combinations.”
- 1.3 BellSouth shall, upon request of Clearwave Communications, and to the extent technically feasible, provide to Clearwave Communications access to its Network Elements for the provision of Clearwave Communications’s telecommunications services. If no rate is identified in this Agreement, the rate for the specific service or function will be as set forth in the applicable BellSouth tariff or as negotiated by the Parties upon request by either Party.
- 1.4 Clearwave Communications may purchase Network Elements and other services from BellSouth for the purpose of combining such network elements in any manner Clearwave Communications chooses to provide telecommunication services to its intended users, including recreating existing BellSouth services. With the exception of the sub-loop Network Elements which are located outside of the central office, BellSouth shall deliver the Network Elements purchased by Clearwave Communications to the demarcation point associated with Clearwave Communications’s collocation arrangement.
- 1.5 BellSouth shall comply with the requirements as set forth in the technical references within this Attachment 2.
- 1.6 Clearwave Communications may not purchase unbundled network elements (UNEs) or convert special access circuits to UNEs if such network elements will be used to provide wireless telecommunications services.
- 1.7 BellSouth shall not connect individual UNEs or combinations of UNEs to BellSouth tariffed services.

- 1.8 If Clearwave Communications reports a trouble on a UNE and no trouble actually exists on the BellSouth portion, BellSouth will charge Clearwave Communications for any dispatching and testing (both inside and outside the CO) required by BellSouth in order to confirm the UNE's working status.
- 1.9 Rates
- 1.9.1 The prices that Clearwave Communications shall pay to BellSouth for Network Elements and Other Services are set forth in Exhibit B to this Attachment. If Clearwave Communications purchases a service(s) from a tariff, all terms and conditions and rates as set forth in such tariff shall apply.
- 1.9.2 Rates, terms and conditions for order cancellation charges and Service Date Advancement Charges will apply in accordance with Attachment 6 and are incorporated herein by this reference.
- 1.9.3 If Clearwave Communications modifies an order (Order Modification Charge (OMC)) after being sent a Firm Order Confirmation (FOC) from BellSouth, any costs incurred by BellSouth to accommodate the modification will be paid by Clearwave Communications in accordance with FCC No. 1 Tariff, Section 5.
- 1.9.4 A one-month minimum billing period shall apply to all UNE conversions or new installations.

## **2 Unbundled Loops**

- 2.1 General
- 2.1.1 The local loop Network Element (Loop) is defined as a transmission facility between a distribution frame (or its equivalent) in BellSouth's central office and the Loop demarcation point at an End User customer premises, including inside wire owned by BellSouth. The local Loop Network Element includes all features, functions, and capabilities of the transmission facilities, including dark fiber and attached electronics (except those used for the provision of advanced services, such as Digital Subscriber Line Access Multiplexers) and line conditioning.
- 2.1.2 The provisioning of a Loop to Clearwave Communications's collocation space will require cross-office cabling and cross-connections within the central office to connect the Loop to a local switch or to other transmission equipment. These cross-connections are separate components that are not considered a part of the Loop, and thus, have a separate charge.
- 2.1.3 To the extent available within BellSouth's network at a particular location, BellSouth will offer Loops capable of supporting telecommunications services. If a requested Loop type is not available and cannot be made available through BellSouth's Unbundled Loop Modification process, then Clearwave Communications can use the Special Construction process to request that

BellSouth place facilities in order to meet Clearwave Communications's Loop requirements. Standard Loop intervals shall not apply to the Special Construction process.

- 2.1.4 Where facilities are available, BellSouth will install Loops in compliance with BellSouth's Products and Services Interval Guide available at the website at <http://www.interconnection.bellsouth.com>. For orders of 15 or more Loops, the installation and any applicable Order Coordination as described below will be handled on a project basis, and the intervals will be set by the BellSouth project manager for that order. When Loops require a Service Inquiry (SI) prior to issuing the order to determine if facilities are available, the interval for the SI process is separate from the installation interval.
- 2.1.5 The Loop shall be provided to Clearwave Communications in accordance with BellSouth's TR73600 Unbundled Local Loop Technical Specification and applicable industry standard technical references.
- 2.1.6 Clearwave Communications may utilize the unbundled Loops to provide telecommunications services as long as such services are consistent with industry standards and BellSouth's TR73600.
- 2.1.7 BellSouth will only provision, maintain and repair the Loops to the standards that are consistent with the type of Loop ordered. In those cases where Clearwave Communications has requested that BellSouth modify a Loop so that it no longer meets the technical parameters of the original Loop type (e.g., voice grade, ISDN, ADSL, etc.), the resulting Loop will be maintained as an unbundled copper Loop (UCL), and Clearwave Communications shall pay the recurring and nonrecurring charges for a UCL. For non-service specific Loops (e.g. UCL, Loops modified by Clearwave Communications using the Unbundled Loop Modification (ULM) process), BellSouth will only support that the Loop has copper continuity and balanced tip-and-ring.
- 2.1.7.1 When a BellSouth technician is required to be dispatched to provision the Loop, BellSouth will tag the Loop with the Circuit ID number and the name of the ordering CLEC. When a dispatch is not required to provision the Loop, BellSouth will tag the Loop on the next required visit to the end user's location. If Clearwave Communications wants to ensure the Loop is tagged during the provisioning process for Loops that may not require a dispatch (e.g. UVL-SL1, UVL-SL2, UCL-ND, Clearwave Communications may order Loop Tagging. Rates for Loop Tagging are as set forth in Exhibit B of this Attachment.
- 2.1.8 **Loop Testing/Trouble Reporting**
- 2.1.8.1 Clearwave Communications will be responsible for testing and isolating troubles on the Loops. Clearwave Communications must test and isolate trouble to the BellSouth portion of a designed/non-designed unbundled Loop (e.g., UVL-SL2,

UCL-D, UVL-SL1, UCL-ND, etc.) before reporting repair to the UNE Customer Wholesale Interconnection Network Services (CWINS) Center. At the time of the trouble report, Clearwave Communications will be required to provide the results of the Clearwave Communications test which indicate a problem on the BellSouth provided Loop.

2.1.8.2 Once Clearwave Communications has isolated a trouble to the BellSouth provided Loop, and had issued a trouble report to BellSouth on the Loop, BellSouth will take the actions necessary to repair the Loop if a trouble actually exists. BellSouth will repair these Loops in the same time frames that BellSouth repairs similarly situated Loops to its end users.

2.1.8.3 If Clearwave Communications reports a trouble on a non-designed or designed Loop and no trouble actually exists, BellSouth will charge Clearwave Communications for any dispatching and testing (both inside and outside the CO) required by BellSouth in order to confirm the Loop's working status.

## 2.1.9 **Order Coordination and Order Coordination-Time Specific**

2.1.9.1 "Order Coordination" (OC) allows BellSouth and Clearwave Communications to coordinate the installation of the SL2 Loops, Unbundled Digital Loops (UDL) and other Loops where OC may be purchased as an option, to Clearwave Communications's facilities to limit end user service outage. OC is available when the Loop is provisioned over an existing circuit that is currently providing service to the end user. OC for physical conversions will be scheduled at BellSouth's discretion during normal working hours on the committed due date. OC shall be provided in accordance with the chart set forth below.

2.1.9.2 "Order Coordination – Time Specific" (OC-TS) allows Clearwave Communications to order a specific time for OC to take place. BellSouth will make every effort to accommodate Clearwave Communications's specific conversion time request. However, BellSouth reserves the right to negotiate with Clearwave Communications a conversion time based on load and appointment control when necessary. This OC-TS is a chargeable option for all Loops except Unbundled Copper Loops (UCL) and Universal Digital Channel (UDC), and is billed in addition to the OC charge. Clearwave Communications may specify a time between 9:00 a.m. and 4:00 p.m. (location time) Monday through Friday (excluding holidays). If Clearwave Communications specifies a time outside this window, or selects a time or quantity of Loops that requires BellSouth technicians to work outside normal work hours, overtime charges will apply in addition to the OC and OC-TS charges. Overtime charges will be applied based on the amount of overtime worked and in accordance with the rates established in the Access Services Tariff, Section E13.2, for each state. The OC-TS charges for an order due on the same day at the same location will be applied on a per Local Service Request (LSR) basis.

2.1.10 **CLEC to CLEC Conversions for Unbundled Loops**

- 2.1.10.1 The CLEC to CLEC conversion process for unbundled Loops may be used by Clearwave Communications when converting an existing unbundled Loop from another CLEC for the same end user. The Loop type being converted must be included in Clearwave Communications's Interconnection Agreement before requesting a conversion.
- 2.1.10.2 To utilize the CLEC to CLEC conversion process, the Loop being converted must be the same Loop type with no requested changes to the Loop, must serve the same end user location from the same serving wire center, and must not require an outside dispatch to provision.
- 2.1.10.3 The Loops converted to Clearwave Communications pursuant to the CLEC to CLEC conversion process shall be provisioned in the same manner and with the same functionality and options as described in this Attachment for the specific Loop type.

2.1.10.4

	<b>Order Coordination (OC)</b>	<b>Order Coordination – Time Specific (OC-TS)</b>	<b>Test Points</b>	<b>DLR</b>	<b>Charge for Dispatch and Testing if No Trouble Found</b>
<b>SL-1 (Non-Designed)</b>	Chargeable Option	Chargeable Option	Not available	Chargeable Option – ordered as Engineering Information Document	Charged for Dispatch inside and outside Central Office
<b>UCL-ND (Non-Designed)</b>	Chargeable Option	Not Available	Not Available	Chargeable Option – ordered as Engineering Information Document	Charged for Dispatch inside and outside Central Office
<b>Unbundled Voice Loops - SL-2 (including 2- and 4-wire UVL) (Designed)</b>	Included	Chargeable Option	Included	Included	Charged for Dispatch outside Central Office
<b>Unbundled Digital Loop (Designed)</b>	Included	Chargeable Option (except on Universal Digital Channel)	Included (where appropriate)	Included	Charged for Dispatch outside Central Office
<b>Unbundled Copper Loop (Designed)</b>	Chargeable in accordance with Section 2	Not available	Included	Included	Charged for Dispatch outside Central Office
For UVL-SL1 and UCLs, Clearwave Communications must order and will be billed for both OC and OC-TS if requesting OC-TS.					

2.2 **Unbundled Voice Loops (UVLs)**

2.2.1 BellSouth shall make available the following UVLs:

2.2.1.1 2-wire Analog Voice Grade Loop – SL1 (Non-Designed)

2.2.1.2 2-wire Analog Voice Grade Loop – SL2 (Designed)

- 2.2.1.3 4-wire Analog Voice Grade Loop (Designed)
- 2.2.2 Unbundled Voice Loops (UVL) may be provisioned using any type of facility that will support voice grade services. This may include loaded copper, non-loaded copper, digital loop carrier systems, fiber or a combination of any of these facilities. BellSouth, in the normal course of maintaining, repairing, and configuring its network, may also change the facilities that are used to provide any given voice grade circuit. This change may occur at any time. In these situations, BellSouth will only ensure that the newly provided facility will support voice grade services. BellSouth will not guarantee that Clearwave Communications will be able to continue to provide any advanced services over the new facility. BellSouth will offer UVL in two different service levels - Service Level One (SL1) and Service Level Two (SL2).
- 2.2.3 Unbundled Voice Loop - SL1 (UVL-SL1) Loops are 2-wire Loop start circuits, will be non-designed, and will not have remote access test points. OC will be offered as a chargeable option on SL1 Loops when reuse of existing facilities has been requested by Clearwave Communications. Clearwave Communications may also order OC-TS when a specified conversion time is requested. OC-TS is a chargeable option for any coordinated order and is billed in addition to the OC charge. An Engineering Information (EI) document can be ordered as a chargeable option. The EI document provides Loop Make-Up information which is similar to the information normally provided in a Design Layout Record. Upon issuance of a non-coordinated order in the service order system, SL1 Loops will be activated on the due date in the same manner and time frames that BellSouth normally activates POTS-type Loops for its end users.
- 2.2.4 For an additional charge BellSouth will make available Loop Testing so that Clearwave Communications may request further testing on new UVL-SL1 Loops. Rates for Loop Testing are as set forth in Exhibit B of this Attachment.
- 2.2.5 Unbundled Voice Loop – SL2 (UVL-SL2) Loops may be 2-wire or 4-wire circuits, shall have remote access test points, and will be designed with a Design Layout Record provided to Clearwave Communications. SL2 circuits can be provisioned with loop start, ground start or reverse battery signaling. OC is provided as a standard feature on SL2 Loops. The OC feature will allow Clearwave Communications to coordinate the installation of the Loop with the disconnect of an existing customer's service and/or number portability service. In these cases, BellSouth will perform the order conversion with standard order coordination at its discretion during normal work hours.
- 2.3 **Unbundled Digital Loops**
- 2.3.1 BellSouth will offer Unbundled Digital Loops (UDL). UDLs are service specific, will be designed, will be provisioned with test points (where appropriate), and will

come standard with OC and a Design Layout Record (DLR). The various UDLs are intended to support a specific digital transmission scheme or service.

- 2.3.2 BellSouth shall make available the following UDLs:
  - 2.3.2.1 2-wire Unbundled ISDN Digital Loop
  - 2.3.2.2 2-wire Universal Digital Channel (IDSL Compatible)
  - 2.3.2.3 2-wire Unbundled ADSL Compatible Loop
  - 2.3.2.4 2-wire Unbundled HDSL Compatible Loop
  - 2.3.2.5 4-wire Unbundled HDSL Compatible Loop
  - 2.3.2.6 4-wire Unbundled DS1 Digital Loop
  - 2.3.2.7 4-wire Unbundled Digital Loop/DS0 – 64 kbps, 56 kbps and below
  - 2.3.2.8 DS3 Loop
  - 2.3.2.9 STS-1 Loop
- 2.3.3 2-Wire Unbundled ISDN Digital Loops will be provisioned according to industry standards for 2-Wire Basic Rate ISDN services and will come standard with a test point, Order Coordination, and a DLR. Clearwave Communications will be responsible for providing BellSouth with a Service Profile Identifier (SPID) associated with a particular ISDN-capable Loop and end user. With the SPID, BellSouth will be able to adequately test the circuit and ensure that it properly supports ISDN service. BellSouth will not reconfigure its ISDN-capable Loop to support IDSL service.
  - 2.3.3.1 The Universal Digital Channel (UDC) (also known as IDSL-compatible Loop) is intended to be compatible with IDSL service and has the same physical characteristics and transmission specifications as BellSouth's ISDN-capable Loop. These specifications are listed in BellSouth's TR73600.
  - 2.3.3.2 The UDC may be provisioned on copper or through a Digital Loop Carrier (DLC) system. When UDC Loops are provisioned using a DLC system, the Loops will be provisioned on time slots that are compatible with data-only services such as IDSL.
- 2.3.4 2-Wire ADSL-Compatible Loop. This is a designed Loop that is provisioned according to Revised Resistance Design (RRD) criteria and may be up to 18kft long and may have up to 6kft of bridged tap (inclusive of Loop length). The Loop is a 2-wire circuit and will come standard with a test point, Order Coordination, and a DLR.



- 2.3.5 2-Wire or 4-Wire HDSL-Compatible Loop. This is a designed Loop that is provisioned according to Carrier Serving Area (CSA) criteria and may be up to 12,000 feet long and may have up to 2,500 feet of bridged tap (inclusive of Loop length). It may be a 2-wire or 4-wire circuit and will come standard with a test point, Order Coordination, and a DLR.
- 2.3.6 4-Wire Unbundled DS1 Digital Loop. This is a designed 4-wire Loop that is provisioned according to industry standards for DS1 or Primary Rate ISDN services and will come standard with a test point, Order Coordination, and a DLR. A DS1 Loop may be provisioned over a variety of loop transmission technologies including copper, HDSL-based technology or fiber optic transport systems. It will include a 4-Wire DS1 Network Interface at the End User's location.
- 2.3.7 4-Wire Unbundled Digital/DS0 Loop. These are designed 4-wire Loops that may be configured as 64kbps, 56kbps, 19kbps, and other sub-rate speeds associated with digital data services and will come standard with a test point, Order Coordination, and a DLR.
- 2.3.8 DS3 Loop. DS3 Loop is a two-point digital transmission path which provides for simultaneous two-way transmission of serial, bipolar, return-to-zero isochronous digital electrical signals at a transmission rate of 44.736 megabits per second (Mbps) that is dedicated to the use of the ordering CLEC in its provisioning of local exchange and associated exchange access services. It may provide transport for twenty-eight (28) DS1 channels, each of which provides the digital equivalent of twenty-four analog voice grade channels. The interface to unbundled dedicated DS3 transport is a metallic-based electrical interface.
- 2.3.9 STS-1 Loop. STS-1 Loop is a high-capacity digital transmission path with SONET VT1.5 mapping that is dedicated for the use of the ordering customer for the purpose of provisioning local exchange and associated exchange access services. It is a two-point digital transmission path which provides for simultaneous two-way transmission of serial bipolar return-to-zero synchronous digital electrical signals at a transmission rate of 51.84 megabits per second (Mbps). It may provide transport for twenty-eight (28) DS1 channels, each of which provides the digital equivalent of twenty-four analog voice grade channels. The interface to unbundled dedicated STS-1 transport is a metallic-based electrical interface.
- 2.3.10 DS3 services come with a test point and a DLR. Mileage is airline miles, rounded up and a minimum of one mile applies. BellSouth TR 73501 LightGate<sup>®</sup> Service Interface and Performance Specifications, Issue D, June 1995 applies to DS3 services.

2.4 **Unbundled Copper Loops (UCL)**

2.4.1 BellSouth shall make available Unbundled Copper Loops (UCLs). The UCL is a copper twisted pair Loop that is unencumbered by any intervening equipment (e.g., filters, load coils, range extenders, digital loop carrier, or repeaters) and is not intended to support any particular telecommunications service. The UCL will be offered in two types – Designed and Non-Designed.

2.4.2 **Unbundled Copper Loop – Designed (UCL-D)**

2.4.2.1 The UCL-D will be provisioned as a dry copper twisted pair Loop that is unencumbered by any intervening equipment (e.g., filters, load coils, range extenders, digital loop carrier, or repeaters). The UCL-D will be offered in two versions - Short and Long.

2.4.2.2 A short UCL-D (18,000 feet or less) is provisioned according to Resistance Design parameters, may have up to 6,000 feet of bridged tap and will have up to 1300 Ohms of resistance.

2.4.2.3 The long UCL-D (beyond 18,000 feet) is provisioned as a dry copper twisted pair longer than 18,000 feet and may have up to 12,000 feet of bridged tap and up to 2800 Ohms of resistance.

2.4.2.4 The UCL-D is a designed circuit, is provisioned with a test point, and comes standard with a DLR. OC is a chargeable option for a UCL-D; however, OC is always required on UCLs where a reuse of existing facilities has been requested by Clearwave Communications.

2.4.2.5 These Loops are not intended to support any particular services and may be utilized by Clearwave Communications to provide a wide-range of telecommunications services as long as those services do not adversely affect BellSouth's network. This facility will include a Network Interface Device (NID) at the customer's location for the purpose of connecting the Loop to the customer's inside wire.

2.4.2.6 BellSouth will make available the following UCL-Ds:

2.4.2.6.1 2-Wire UCL-D/short

2.4.2.6.2 2-Wire UCL-D/long

2.4.2.6.3 4-Wire UCL-D/short

2.4.2.6.4 4-Wire UCL-D/long

2.4.3 **Unbundled Copper Loop – Non-Designed (UCL-ND)**

2.4.3.1 The UCL-ND is provisioned as a dedicated 2-wire metallic transmission facility from BellSouth's Main Distribution Frame to a customer's premises (including the

NID). The UCL-ND will be a “dry copper” facility in that it will not have any intervening equipment such as load coils, repeaters, or digital access main lines (DAMLs), and may have up to 6,000 feet of bridged tap between the end user’s premises and the serving wire center. The UCL-ND typically will be 1300 Ohms resistance and in most cases will not exceed 18,000 feet in length, although the UCL-ND will not have a specific length limitation. For Loops less than 18,000 feet and with less than 1300 Ohms resistance, the Loop will provide a voice grade transmission channel suitable for Loop start signaling and the transport of analog voice grade signals. The UCL-ND will not be designed and will not be provisioned with either a DLR or a test point.

- 2.4.3.2 The UCL-ND facilities may be mechanically assigned using BellSouth’s assignment systems. Therefore, the Loop Make Up process is not required to order and provision the UCL-ND. However, Clearwave Communications can request Loop Make Up for which additional charges would apply.
- 2.4.3.3 For an additional charge, BellSouth also will make available Loop Testing so that Clearwave Communications may request further testing on the UCL-ND. Rates for Loop Testing are as set forth in Exhibit B of this Attachment.
- 2.4.3.4 UCL-ND Loops are not intended to support any particular service and may be utilized by Clearwave Communications to provide a wide-range of telecommunications services as long as those services do not adversely affect BellSouth’s network. The UCL-ND will include a Network Interface Device (NID) at the customer’s location for the purpose of connecting the Loop to the customer’s inside wire.
- 2.4.3.5 Order Coordination (OC) will be provided as a chargeable option and may be utilized when the UCL-ND provisioning is associated with the reuse of BellSouth facilities. Order Coordination -Time Specific (OC-TS) does not apply to this product.
- 2.4.3.6 Clearwave Communications may use BellSouth’s Unbundled Loop Modification (ULM) offering to remove bridge tap and/or load coils from any Loop within the BellSouth network. Therefore, some Loops that would not qualify as UCL-ND could be transformed into Loops that do qualify, using the ULM process.

## 2.5 **Unbundled Loop Modifications (Line Conditioning)**

- 2.5.1 Line Conditioning is defined as the removal from the Loop of any devices that may diminish the capability of the Loop to deliver high-speed switched wireline telecommunications capability, including xDSL service. Such devices include, but are not limited to, load coils, bridged taps, low pass filters, and range extenders.
- 2.5.2 BellSouth shall condition Loops, as requested by Clearwave Communications, whether or not BellSouth offers advanced services to the End User on that Loop.

- 2.5.3 In some instances, Clearwave Communications will require access to a copper twisted pair Loop unfettered by any intervening equipment (e.g., filters, load coils, range extenders, etc.), so that Clearwave Communications can use the Loop for a variety of services by attaching appropriate terminal equipment at the ends. Clearwave Communications will determine the type of service that will be provided over the Loop. BellSouth's Unbundled Loop Modifications (ULM) process will be used to determine the costs and feasibility of conditioning the Loops as requested. Rates for ULM are as set forth in Exhibit B of this Attachment.
- 2.5.4 In those cases where Clearwave Communications has requested that BellSouth modify a Loop so that it no longer meets the technical parameters of the original Loop type (e.g., voice grade, ISDN, ADSL, etc.), the resulting modified Loop will be ordered and maintained as a UCL.
- 2.5.5 ULM includes the following: 1) removal of devices on 2-wire or 4-wire Loops equal to or less than 18,000 feet; 2) removal of devices on 2-wire or 4-wire Loops longer than 18,000 feet; and 3) removal of bridged-taps on Loops of any length.
- 2.5.6 Clearwave Communications shall request Loop make up information pursuant to this Attachment prior to submitting a service inquiry and/or a LSR for the Loop type that Clearwave Communications desires BellSouth to condition.
- 2.5.7 When requesting ULM for a Loop that BellSouth has previously provisioned for Clearwave Communications, Clearwave Communications will submit a service inquiry to BellSouth. If a spare Loop facility that meets the loop modification specifications requested by Clearwave Communications is available at the location for which the ULM was requested, Clearwave Communications will have the option to change the Loop facility to the qualifying spare facility rather than to provide ULM. In the event that BellSouth changes the Loop facility in lieu of providing ULM, Clearwave Communications will not be charged for ULM but will only be charged the service order charges for submitting an order.

## 2.6 **Loop Provisioning Involving Integrated Digital Loop Carriers**

- 2.6.1 Where Clearwave Communications has requested an Unbundled Loop and BellSouth uses Integrated Digital Loop Carrier (IDLC) systems to provide the local service to the end user and BellSouth has a suitable alternate facility available, BellSouth will make such alternative facilities available to Clearwave Communications. If a suitable alternative facility is not available, then to the extent it is technically feasible, BellSouth will implement one of the following alternative arrangements for Clearwave Communications (e.g. hairpinning):
1. Roll the circuit(s) from the IDLC to any spare copper that exists to the customer premises.
  2. Roll the circuit(s) from the IDLC to an existing DLC that is not integrated.
  3. If capacity exists, provide "side-door" porting through the switch.

4. If capacity exists, provide "DACS-door" porting (if the IDLC routes through a DACS prior to integration into the switch).

2.6.2 Arrangements 3 and 4 above require the use of a designed circuit. Therefore, non-designed Loops such as the SL1 voice grade and UCL-ND may not be ordered in these cases.

2.6.3 If no alternate facility is available, BellSouth will utilize its Special Construction (SC) process to determine the additional costs required to provision the Loop facilities. Clearwave Communications will then have the option of paying the one-time SC rates to place the Loop.

## 2.7 **Network Interface Device (NID)**

2.7.1 The NID is defined as any means of interconnection of End User customer premises wiring to BellSouth's distribution plant, such as a cross-connect device used for that purpose. The NID is a single-line termination device or that portion of a multiple-line termination device required to terminate a single line or circuit at the premises. The NID features two independent chambers or divisions that separate the service provider's network from the end user's customer-premises wiring. Each chamber or division contains the appropriate connection points or posts to which the service provider and the end user each make their connections. The NID provides a protective ground connection and is capable of terminating cables such as twisted pair cable.

2.7.2 BellSouth shall permit Clearwave Communications to connect Clearwave Communications's Loop facilities to the End User's customer-premises wiring through the BellSouth NID or at any other technically feasible point.

## 2.7.3 **Access to NID**

2.7.3.1 Clearwave Communications may access the end user's customer-premises wiring by any of the following means and Clearwave Communications shall not disturb the existing form of electrical protection and shall maintain the physical integrity of the NID:

2.7.3.1.1 BellSouth shall allow Clearwave Communications to connect its Loops directly to BellSouth's multi-line residential NID enclosures that have additional space and are not used by BellSouth or any other telecommunications carriers to provide service to the premises.

2.7.3.1.2 Where an adequate length of the end user's customer premises wiring is present and environmental conditions permit, either Party may remove the customer premises wiring from the other Party's NID and connect such wiring to that Party's own NID;

- 2.7.3.1.3 Either Party may enter the subscriber access chamber or dual chamber NID enclosures for the purpose of extending a connect divisioned or spliced jumper wire from the customer premises wiring through a suitable “punch-out” hole of such NID enclosures; or
- 2.7.3.1.4 Clearwave Communications may request BellSouth to make other rearrangements to the end user customer premises wiring terminations or terminal enclosure on a time and materials cost basis.
- 2.7.3.2 In no case shall either Party remove or disconnect the other Party’s Loop facilities from either Party’s NIDs, enclosures, or protectors unless the applicable Commission has expressly permitted the same and the disconnecting Party provides prior notice to the other Party. In such cases, it shall be the responsibility of the Party disconnecting Loop facilities to leave undisturbed the existing form of electrical protection and to maintain the physical integrity of the NID. It will be Clearwave Communications’s responsibility to ensure there is no safety hazard, and Clearwave Communications will hold BellSouth harmless for any liability associated with the removal of the BellSouth Loop from the BellSouth NID. Furthermore, it shall be the responsibility of the disconnecting Party, once the other Party’s Loop has been disconnected from the NID, to reconnect the disconnected Loop to a nationally recognized testing laboratory listed station protector, which has been grounded as per Article 800 of the National Electrical Code. If no spare station protector exists in the NID, the disconnected Loop must be appropriately cleared, capped and stored.
- 2.7.3.3 Clearwave Communications shall not remove or disconnect ground wires from BellSouth’s NIDs, enclosures, or protectors.
- 2.7.3.4 Clearwave Communications shall not remove or disconnect NID modules, protectors, or terminals from BellSouth’s NID enclosures.
- 2.7.3.5 Due to the wide variety of NID enclosures and outside plant environments, BellSouth will work with Clearwave Communications to develop specific procedures to establish the most effective means of implementing this section if the procedures set forth herein do not apply to the NID in question.
- 2.7.4 Technical Requirements
- 2.7.4.1 The NID shall provide an accessible point of interconnection and shall maintain a connection to ground.
- 2.7.4.2 If an existing NID is accessed, it shall be capable of transferring electrical analog or digital signals between the end user’s customer premises and the distribution media and/or cross connect to Clearwave Communications’s NID.
- 2.7.4.3 Existing BellSouth NIDs will be provided in “as is” condition. Clearwave Communications may request BellSouth to do additional work to the NID on a

time and material basis. When Clearwave Communications deploys its own local Loops in a multiple-line termination device, Clearwave Communications shall specify the quantity of NIDs connections that it requires within such device.

## 2.8 **Sub-loop Elements**

2.8.1 Where facilities permit, BellSouth shall offer access to its Unbundled Sub-Loop (USL) and Unbundled Sub-loop Concentration (USLC) System.

## 2.8.2 **Unbundled Sub-Loop Distribution**

2.8.2.1 The unbundled sub-loop distribution facility is a dedicated transmission facility that BellSouth provides from an end user's point of demarcation to a BellSouth cross-connect device. The BellSouth cross-connect device may be located within a remote terminal (RT) or a stand-alone cross-box in the field or in the equipment room of a building. The unbundled sub-loop distribution media is a copper twisted pair that can be provisioned as a 2-Wire or 4-Wire facility. BellSouth will make available the following sub-loop distribution offerings where facilities exist:

Unbundled Sub-Loop Distribution – Voice Grade

Unbundled Copper Sub-Loop

Unbundled Sub-Loop Distribution – Intrabuilding Network Cable (aka riser cable)

2.8.2.2 Unbundled Sub-Loop Distribution – Voice Grade (USLD-VG) is a sub-loop facility from the cross-box in the field up to and including the point of demarcation at the end user's premises and may have load coils.

2.8.2.3 Unbundled Copper Sub-Loop (UCSL) is a copper facility of any length provided from the cross-box in the field up to and including the End User's point of demarcation. If available, this facility will not have any intervening equipment such as load coils between the End User and the cross-box.

2.8.2.4 If Clearwave Communications requests a UCSL and it is not available, Clearwave Communications may request the Sub-Loop facility be modified pursuant to the ULM process to remove load coils and/or bridged taps. If load coils and/or bridged taps are removed, the facility will be classified as a UCSL.

2.8.2.5 Unbundled Sub-Loop Distribution – Intrabuilding Network Cable (USLD-INC) is the distribution facility inside a building or between buildings on the same property that is not separated by a public street or road. USLD-INC includes the facility from the cross-connect device in the building equipment room up to and including the point of demarcation at the end user's premises.

2.8.2.6 BellSouth will install a cross connect panel in the building equipment room for the purpose of accessing USLD-INC pairs from a building equipment room. The cross-connect panel will function as a single point of interconnection (SPOI) for USLD-INC and will be accessible by multiple carriers as space permits. BellSouth

will place cross-connect blocks in 25-pair increments for Clearwave Communications's use on this cross-connect panel. Clearwave Communications will be responsible for connecting its facilities to the 25-pair cross-connect block(s).

- 2.8.2.7 For access to Voice Grade USLD and UCSL, Clearwave Communications shall install a cable to the BellSouth cross-box pursuant to the terms and conditions for physical collocation for remote sites set forth in this Agreement. This cable would be connected by a BellSouth technician within the BellSouth cross-box during the set-up process. Clearwave Communications's cable pairs can then be connected to BellSouth's USL within the BellSouth cross-box by the BellSouth technician.
- 2.8.2.8 Through the Service Inquiry (SI) process, BellSouth will determine whether access to Unbundled Sub-Loops at the location requested by Clearwave Communications is technically feasible and whether sufficient capacity exists in the cross-box. If existing capacity is sufficient to meet Clearwave Communications's request, then BellSouth will perform the site set-up as described in the CLEC Information Package, located at the Website address: <http://www.interconnection.bellsouth.com/products/html/unes.html>. If any work must be done to modify existing BellSouth facilities or add new facilities (other than adding the cross-connect panel in a building equipment room to accommodate Clearwave Communications's request for Unbundled Sub-Loops, Clearwave Communications may request BellSouth's Special Construction (SC) process to determine additional costs required to provision the Unbundled Sub-Loops. Clearwave Communications will have the option to proceed under the SC process to modify the BellSouth facilities.
- 2.8.2.9 The site set-up must be completed before Clearwave Communications can order sub-loop pairs. For the site set-up in a BellSouth cross-connect box in the field, BellSouth will perform the necessary work to splice Clearwave Communications's cable into the cross-connect box. For the site set-up inside a building equipment room, BellSouth will perform the necessary work to install the cross-connect panel and the connecting block(s) that will be used to provide access to the requested USLs.
- 2.8.2.10 Once the site set-up is complete, Clearwave Communications will request sub-loop pairs through submission of a Local Service Request (LSR) form to the Local Carrier Service Center (LCSC). Order Coordination is required with USL pair provisioning when Clearwave Communications requests reuse of an existing facility, and the Order Coordination charge shall be billed in addition to the USL pair rate. For expedite requests by Clearwave Communications for sub-loop pairs, expedite charges will apply for intervals less than 5 days.
- 2.8.2.11 Unbundled Sub-Loops will be provided in accordance with technical reference TR73600.



### 2.8.3 **Unbundled Network Terminating Wire (UNTW)**

- 2.8.3.1 Unbundled Network Terminating Wire (UNTW) is unshielded twisted copper wiring that is used to extend circuits from an intra-building network cable terminal or from a building entrance terminal to an individual end user's point of demarcation. It is the final portion of the Loop that in multi-subscriber configurations represents the point at which the network branches out to serve individual subscribers.
- 2.8.3.2 This element will be provided in Multi-Dwelling Units (MDUs) and/or Multi-Tenants Units (MTUs) where either Party owns wiring all the way to the End User's premises. Neither Party will provide this element in locations where the property owner provides its own wiring to the End User's premises, where a third party owns the wiring to the End User's premises or where the property owner will not allow the other Party to place its facilities to the end user.
- 2.8.3.3 Requirements
- 2.8.3.3.1 On a multi-unit premises, upon request of the other Party (Requesting Party), the Party owning the network terminating wire (Provisioning Party) will provide access to UNTW pairs on an Access Terminal that is suitable for use by multiple carriers at each Garden Terminal or Wiring Closet.
- 2.8.3.3.2 The Provisioning Party shall not be required to install new or additional NTW beyond existing NTW to provision the services of the Requesting Party.
- 2.8.3.3.3 In existing MDUs and/or MTUs in which BellSouth does not own or control wiring (INC/NTW) to the end users premises, Clearwave Communications will install UNTW Access Terminals for BellSouth at no additional charge.
- 2.8.3.3.4 In situations in which BellSouth activates a UNTW pair, BellSouth will compensate Clearwave Communications for each pair activated commensurate to the price specified in Clearwave Communications's Agreement.
- 2.8.3.3.5 Upon receipt of the UNTW Service Inquiry (SI) requesting access to the Provisioning Party's UNTW pairs at a multi-unit premises, representatives of both Parties will participate in a meeting at the site of the requested access. The purpose of the site visit will include discussion of the procedures for installation and location of the Access Terminals. By request of the Requesting Party, an Access Terminal will be installed either adjacent to each of the Provisioning Party's Garden Terminal or inside each Wiring Closet. The Requesting Party will deliver and connect its central office facilities to the UNTW pairs within the Access Terminal. The Requesting Party may access any available pair on an Access Terminal. A pair is available when a pair is not being utilized to provide service or where the end user has requested a change in its local service provider to the Requesting Party. Prior to connecting the Requesting Party's service on a

pair previously used by the Provisioning Party, the Requesting Party is responsible for ensuring the End User is no longer using the Provisioning Party's service or another CLEC's service before accessing UNTW pairs.

- 2.8.3.3.6 Access Terminal installation intervals will be established on an individual case basis.
- 2.8.3.3.7 The Requesting Party is responsible for obtaining the property owner's permission for the Provisioning Party to install an Access Terminal(s) on behalf of the Requesting Party. The submission of the SI by the Requesting Party will serve as certification by the Requesting Party that such permission has been obtained. If the property owner objects to Access Terminal installations that are in progress or subsequent to completion and demands removal of Access Terminals, the Requesting Party will be responsible for costs associated with removing Access Terminals and restoring the property to its original state prior to Access Terminals being installed.
- 2.8.3.3.8 The Requesting Party shall indemnify and hold harmless the Provisioning Party against any claims of any kind that may arise out of the Requesting Party's failure to obtain the property owner's permission. The Requesting Party will be billed for nonrecurring and recurring charges for accessing UNTW pairs at the time the Requesting Party activates the pair(s). The Requesting Party will notify the Provisioning Party each time it activates UNTW pairs using the LSR form.
- 2.8.3.3.9 The Requesting Party will isolate and report troubles in the manner specified by the Provisioning Party. The Requesting Party must tag the UNTW pair that requires repair. If the Provisioning Party dispatches a technician on a reported trouble call and no UNTW trouble is found, the Provisioning Party will charge Requesting Party for time spent on the dispatch and testing the UNTW pair(s).
- 2.8.3.3.10 If the Requesting Party initiates the Access Terminal installation and the Requesting Party has not activated at least one pair on the Access Terminal installed pursuant to the Requesting Party's request for an Access Terminal within 6 months of installation of the Access Terminal, the Provisioning Party will bill the Requesting Party a nonrecurring charge equal to the actual cost of provisioning the Access Terminal.
- 2.8.3.3.11 If the Provisioning Party determines that the Requesting Party is using the UNTW pairs without reporting the activation of the pairs, the following charges shall apply:
  - 2.8.3.3.11.1 If the Requesting Party issued a LSR to disconnect an End User from the Provisioning Party in order to use a UNTW pair, the Requesting Party will be billed for the use of the pair back to the disconnect order date.

- 2.8.3.3.11.2 If the Requesting Party activated a UNTW pair on which the Provisioning Party was not previously providing service, the Requesting Party will be billed for the use of that pair back to the date the End User began receiving service using that pair. Upon request, the Requesting Party will provide copies of its billing record to substantiate such date. If the Requesting Party fails to provide such records, then the Provisioning Party will bill the Requesting Party back to the date of the Access Terminal installation.
- 2.8.4 **Unbundled Sub-Loop Feeder**
- 2.8.4.1 Unbundled Sub-Loop Feeder (USLF) provides connectivity between BellSouth's central office and cross-box (or other access point) that serves one or more end user locations.
- 2.8.4.2 USLF utilized for voice traffic can be configured as 2-wire voice (USLF-2W/V) or 4-wire voice (USLF-4W/V).
- 2.8.4.3 USLF utilized for digital traffic can be configured as 2-wire ISDN (USLF-2W/I); 2-wire Copper (USLF-2W/C); 4-wire Copper (USLF-4W/C); 4-wire DS0 level Loop (USLF-4W/D0); or 4-wire DS1 and ISDN (USLF-4W/DI).
- 2.8.4.4 USLF will provide access to both the equipment and the features in the BellSouth central office and BellSouth cross box necessary to provide a 2-wire or 4-wire communications pathway from the BellSouth central office to the BellSouth cross-box. This element will allow for the connection of Clearwave Communications's loop distribution elements onto BellSouth's feeder system.
- 2.8.4.5 Requirements
- 2.8.4.5.1 Clearwave Communications will extend a compatible cable to BellSouth's cross-box. BellSouth will connect the cable to a cross-connect panel inside the BellSouth cross-box to the requested level of feeder element. In those cases in which there is no room in the BellSouth cross-box to accommodate the additional cross-connect panels mentioned above, Clearwave Communications may request, through the BellSouth Special Construction process, a determination of costs to provide the sub-loop feeder element to Clearwave Communications. Clearwave Communications will then have the option of paying the special construction charges or canceling the order.
- 2.8.4.5.2 USLF will be a designed circuit and BellSouth will provide a Design Layout Record (DLR) for this element.
- 2.8.4.5.3 BellSouth will provide USLF elements in accordance with applicable industry standards for these types of facilities. Where industry standards do not exist, BellSouth's TR73600 will be used to determine performance parameters.
- 2.8.4.6 Unbundled Sub-Loop Feeder – DS3 and above

- 2.8.4.6.1 USLF DS3 and above provides connectivity between a BellSouth Serving Wire Center (SWC) collocation arrangement and the Remote Terminal (RT) associated with the SWC that serves an end user location.
- 2.8.4.6.2 The sub-loop feeder shall be utilized for voice and digital traffic. It may be configured at DS3 or STS-1 transmission capacities and shall require a Service Inquiry.
- 2.8.4.7 Requirements
- 2.8.4.7.1 Access in the SWC and RT will be via a Collocation cross-connect.
- 2.8.4.7.2 USLF DS3 and above will be a designed circuit. BellSouth will provide a Design Layout Record (DLR) for this network element.
- 2.8.4.7.3 Rates. Rates for these services are as set forth in Exhibit B of this Attachment. Mileage is based on airline miles.
- 2.8.4.7.4 BellSouth will provide USLF DS3 and above elements in accordance with applicable industry standards.
- 2.8.5 **Unbundled Loop Concentration (ULC)**
- 2.8.5.1 BellSouth will provide to Clearwave Communications Unbundled Loop Concentration (ULC). Loop concentration systems in the central office concentrate the signals transmitted over local Loops onto a digital loop carrier system. The concentration device is placed inside a BellSouth central office. BellSouth will offer ULC with a TR008 interface or a TR303 interface.
- 2.8.5.2 ULC will be offered in two system options. System A will allow up to 96 BellSouth Loops to be concentrated onto two or more DS1s. The high-speed connection from the concentrator will be at the electrical DS1 level and will connect to Clearwave Communications at Clearwave Communications's collocation site. System B will allow up to 192 BellSouth Loops to be concentrated onto 4 or more DS1s. System A may be upgraded to a System B. A minimum of two DS1s is required for each system (i.e., System A requires two DS1s and System B would require an additional two DS1s or four in total). All DS1 interfaces will terminate to Clearwave Communications's collocation space. ULC service is offered with concentration (2 DS1s for 96 channels) or without concentration (4 DS1s for 96 channels) and with or without protection. A Loop Interface element will be required for each Loop that is terminated onto the ULC system.
- 2.8.6 **Unbundled Sub-Loop Concentration (USLC)**
- 2.8.6.1 Where facilities permit, Clearwave Communications may concentrate its sub-loops onto multiple DS1s back to the BellSouth Central Office.

2.8.6.2 USLC, using the Lucent Series 5 equipment, will be offered in two system options. System A will allow up to 96 of Clearwave Communications's sub-loops to be concentrated onto two or more DS1s. System B will allow an additional 96 of Clearwave Communications's sub-loops to be concentrated onto two or more additional DS1s. One System A may be supplemented with one System B and they both must be physically located in a single Series 5 dual channel bank. A minimum of two DS1s is required for each system (i.e., System A requires two DS1s and System B would require an additional two DS1s or four in total). The DS1 level facility that connects the Remote Terminal site with the serving wire center is known as a Feeder Interface. All DS1 Feeder Interfaces will terminate to Clearwave Communications's demarcation point associated with Clearwave Communications's collocation space within the SWC that serves the remote terminal (RT). USLC service is offered with or without concentration and with or without a protection DS1.

2.8.6.3 Clearwave Communications is required to deliver its sub-loops to its own cross-box, RT, or other similar device and deliver a single cable to the BellSouth RT. This cable shall be connected by a BellSouth technician to a cross-connect panel within the BellSouth RT/cross-box and shall allow Clearwave Communications's sub-loops to be placed on the USLC and transported to Clearwave Communications's collocation space at a DS1 level.

## 2.8.7 **Dark Fiber Loop**

2.8.7.1 Dark Fiber Loop is an unused optical transmission facility, without attached signal regeneration, multiplexing, aggregation or other electronics, from an end user's premises connected via a cross connect to the demarcation point associated with Clearwave Communications's collocation space in the end user's serving wire center. Dark Fiber Loops may be strands of optical fiber existing in aerial or underground structure. BellSouth will not provide line terminating elements, regeneration or other electronics necessary for Clearwave Communications to utilize Dark Fiber Loops.

### 2.8.7.2 Requirements

2.8.7.2.1 BellSouth shall make available Dark Fiber Loop where it exists in BellSouth's network and where, as a result of future building or deployment, it becomes available. Dark Fiber Loop will not be deemed available if: (1) it is used by BellSouth for maintenance and repair purposes; (2) it is designated for use pursuant to a firm order placed by another customer; (3) it is restricted for use by all carriers, including BellSouth, because of transmission problems or because it is scheduled for removal due to documented changes to roads and infrastructure; or (4) BellSouth has plans to use the fiber within a two-year planning period. BellSouth is not required to place the fiber for Dark Fiber Loop if none is available.

- 2.8.7.2.2 Clearwave Communications is solely responsible for testing the quality of the Dark Fiber to determine its usability and performance specifications.
- 2.8.7.2.3 BellSouth shall use its commercially reasonable efforts to provide to Clearwave Communications information regarding the location, availability and performance of Dark Fiber Loop within ten (10) business days after receiving a Service Inquiry (SI) from Clearwave Communications.
- 2.8.7.2.4 If the requested Dark Fiber Loop is available, BellSouth shall use commercially reasonable efforts to provision the Dark Fiber Loop to Clearwave Communications within twenty (20) business days after Clearwave Communications submits a valid, error free LSR. Provisioning includes identification of appropriate connection points (e.g., Light Guide Interconnection (LGX)) to enable Clearwave Communications to connect Clearwave Communications provided transmission media (e.g., optical fiber) or equipment to the Dark Fiber Loop.

## 2.9 **Loop Makeup (LMU)**

### 2.9.1 Description of Service

- 2.9.1.1 BellSouth shall make available to Clearwave Communications LMU information so that Clearwave Communications can make an independent judgment about whether the Loop is capable of supporting the advanced services equipment Clearwave Communications intends to install and the services Clearwave Communications wishes to provide. This section addresses LMU as a preordering transaction, distinct from Clearwave Communications ordering any other service(s). Loop Makeup Service Inquiries (LMUSI) for preordering Loop Make-Up are likewise unique from other preordering functions with associated service inquiries (SI) as described in this Agreement.
- 2.9.1.2 BellSouth will provide Clearwave Communications LMU information consisting of the composition of the Loop material (copper/fiber); the existence, location and type of equipment on the Loop, including but not limited to digital loop carrier or other remote concentration devices, feeder/distribution interfaces, bridged taps, load coils, pair-gain devices; the Loop length; the wire gauge and electrical parameters.
- 2.9.1.3 BellSouth's LMU information is provided to Clearwave Communications as it exists either in BellSouth's databases or in its hard copy facility records. BellSouth does not guarantee accuracy or reliability of the LMU information provided.
- 2.9.1.4 BellSouth's provisioning of LMU information to the requesting CLEC on facilities is contingent upon either BellSouth or the requesting CLEC controlling the Loop(s) that serve the service location for which LMU information has been requested by the CLEC. The requesting CLEC is not authorized to receive LMU information on a facility used or controlled by another CLEC unless BellSouth

receives a Letter of Authorization (LOA) from the voice CLEC (owner) or its authorized agent on the LMUSI (Loop Makeup Service Inquiry) submitted by the requesting CLEC.

- 2.9.1.5 Clearwave Communications may choose to use equipment that it deems will enable it to provide a certain type and level of service over a particular BellSouth Loop as long as that equipment does not disrupt other services on the BellSouth network. The determination shall be made solely by Clearwave Communications and BellSouth shall not be liable in any way for the performance of the advanced data services provisioned over said Loop. The specific Loop type (ADSL, HDSL, or otherwise) ordered on the LSR must match the LMU of the Loop reserved taking into consideration any requisite line conditioning. The LMU data is provided for informational purposes only and does not guarantee Clearwave Communications's ability to provide advanced data services over the ordered Loop type. Further, if Clearwave Communications orders Loops that do not require a specific facility medium (i.e. copper only) or Loops that are not intended to support advanced services (such as UV-SL1, UV-SL2, or ISDN compatible Loops) and that are not inventoried as advanced services Loops, the LMU information for such Loops is subject to change at any time due to modifications and/or upgrades to BellSouth's network. Clearwave Communications is fully responsible for any of its service configurations that may differ from BellSouth's technical standard for the Loop type ordered.

## 2.9.2 **Submitting Loop Makeup Service Inquiries**

- 2.9.2.1 Clearwave Communications may obtain LMU information by submitting a LMU Service Inquiry (LMUSI) mechanically or manually. Mechanized LMUSIs should be submitted through BellSouth's Operational Support Systems interfaces. After obtaining the Loop information from the mechanized LMUSI process, if Clearwave Communications needs further Loop information in order to determine Loop service capability, Clearwave Communications may initiate a separate Manual Service Inquiry for a separate nonrecurring charge as set forth in Exhibit B of this Attachment.

- 2.9.2.2 Manual LMUSIs shall be submitted by electronic mail to BellSouth's Complex Resale Support Group (CRSG) utilizing the Preordering Loop Makeup Service Inquiry form. The service interval for the return of a Loop Makeup Manual Service Inquiry is three business days. Manual LMUSIs are not subject to expedite requests. This service interval is distinct from the interval applied to the subsequent service order.

## 2.9.3 **Loop Reservations**

- 2.9.3.1 For a Mechanized LMUSI, Clearwave Communications may reserve up to ten Loop facilities. For a Manual LMUSI, Clearwave Communications may reserve up to three Loop facilities.

2.9.3.2 Clearwave Communications may reserve facilities for up to four (4) business days for each facility requested on a LMUSI from the time the LMU information is returned to Clearwave Communications. During and prior to Clearwave Communications placing an LSR, the reserved facilities are rendered unavailable to other customers, including BellSouth. If Clearwave Communications does not submit an LSR for a UNE service on a reserved facility within the four-day reservation timeframe, the reservation of that spare facility will become invalid and the facility will be released.

2.9.3.3 Charges for preordering LMUSI are separate from any charges associated with ordering other services from BellSouth.

#### 2.9.4 **Ordering of Other UNE Services**

2.9.4.1 All LSRs issued for reserved facilities shall reference the facility reservation number as provided by BellSouth. Clearwave Communications will not be billed any additional LMU charges for the Loop ordered on such LSR. If, however, Clearwave Communications does not reserve facilities upon an initial LMUSI, Clearwave Communications's placement of an order for an advanced data service type facility will incur the appropriate billing charges to include service inquiry and reservation per Exhibit B of this Attachment.

2.9.4.2 Where Clearwave Communications has reserved multiple Loop facilities on a single reservation, Clearwave Communications may not specify which facility shall be provisioned when submitting the LSR. For those occasions, BellSouth will assign to Clearwave Communications, subject to availability, a facility that meets the BellSouth technical standards of the BellSouth type Loop as ordered by Clearwave Communications. If the ordered Loop type is not available, Clearwave Communications may utilize the Unbundled Loop Modification process or the Special Construction process, as applicable, to obtain the Loop type ordered.

### **3 High Frequency Spectrum Network Element**

#### 3.1 General

3.1.1 BellSouth shall provide Clearwave Communications access to the high frequency spectrum of the local Loop as an unbundled network element only where BellSouth is the voice service provider to the end user at the rates set forth in this Attachment.

3.1.2 The High Frequency Spectrum is defined as the frequency range above the voiceband on a copper Loop facility carrying analog circuit-switched voiceband transmissions. Access to the High Frequency Spectrum is intended to allow Clearwave Communications the ability to provide Digital Subscriber Line (xDSL) data services to the end user for which BellSouth provides voice services. The High Frequency Spectrum shall be available for any version of xDSL complying



with Spectrum Management Class 5 of ANSI T1.417, American National Standard for Telecommunications, Spectrum Management for Loop Transmission Systems. BellSouth will continue to have access to the low frequency portion of the Loop spectrum (from 300 Hertz to at least 3000 Hertz, and potentially up to 3400 Hertz, depending on equipment and facilities) for the purposes of providing voice service. Clearwave Communications shall only use xDSL technology that is within the PSD mask for Spectrum Management Class 5 as found in the above-mentioned document.

- 3.1.3 Access to the High Frequency Spectrum requires an unloaded, 2-wire copper Loop. An unloaded Loop is a copper Loop with no load coils, low-pass filters, range extenders, DAMLs, or similar devices and minimal bridged taps consistent with ANSI T1.413 and T1.601.
- 3.1.4 BellSouth will provide Loop Modification to Clearwave Communications on an existing Loop in accordance with procedures developed in the Line Sharing Collaborative. High Frequency Spectrum (Central Office Based) Unbundled Loop Modification is a separate distinct service from Unbundled Loop Modification set forth in Section 2.5 of this Attachment. Procedures for High Frequency Spectrum (Central Office Based) Unbundled Loop Modification were developed in the Line Sharing Collaborative and may be found posted to the web at <http://www.interconnection.bellsouth.com/html/unes.html>. Nonrecurring rates for this UNE offering are as set forth in Exhibit B of this Attachment. BellSouth is not required to modify a Loop for access to the High Frequency spectrum if modification of that Loop significantly degrades BellSouth's voice service. If Clearwave Communications requests that BellSouth modify a Loop longer than 18,000 ft. and such modification significantly degrades the voice services on the Loop, Clearwave Communications shall pay for the Loop to be restored to its original state.
- 3.1.5 The High Frequency Spectrum shall only be available on Loops on which BellSouth is also providing, and continues to provide, analog voice service directly to the end user. In the event the End User terminates its BellSouth provided voice service for any reason, or in the event BellSouth disconnects the end user's voice service pursuant to its tariffs or applicable law, and Clearwave Communications desires to continue providing xDSL service on such Loop, Clearwave Communications shall be required to purchase a full stand-alone Loop unbundled network element. To the extent commercially practicable, BellSouth shall give Clearwave Communications notice in a reasonable time prior to disconnect, which notice shall give Clearwave Communications an adequate opportunity to notify BellSouth of its intent to purchase such Loop. In those cases in which BellSouth no longer provides voice service to the end user and Clearwave Communications purchases the full stand-alone Loop, Clearwave Communications may elect the type of Loop it will purchase. Clearwave Communications will pay the appropriate recurring and nonrecurring rates for such Loop as set forth in Exhibit B to this Attachment. In the event Clearwave Communications purchases a voice

grade Loop, Clearwave Communications acknowledges that such Loop may not remain xDSL compatible.

- 3.1.6 Only one competitive local exchange carrier (CLEC) shall be permitted access to the High Frequency Spectrum of any particular Loop.

3.2 **Provisioning of High Frequency Spectrum and Splitter Space**

- 3.2.1 BellSouth will provide Clearwave Communications with access to the High Frequency Spectrum as follows:

3.2.1.1 To order High Frequency Spectrum on a particular Loop, Clearwave Communications must have a Digital Subscriber Line Access Multiplexer (DSLAM) collocated in the central office that serves the End User of such Loop.

3.2.1.2 Clearwave Communications may provide its own splitters or may order splitters in a central office once it has installed its DSLAM in that central office. BellSouth will install splitters within thirty-six (36) calendar days of Clearwave Communications's submission of an error free Line Splitter Ordering Document (LSOD) to the BellSouth Complex Resale Support Group.

3.2.1.3 Once a splitter is installed on behalf of Clearwave Communications in a central office in which Clearwave Communications is located, Clearwave Communications shall be entitled to order the High Frequency Spectrum on lines served out of that central office. BellSouth will bill and Clearwave Communications shall pay the electronic or manual ordering charges as applicable when Clearwave Communications orders High Frequency Spectrum for End User service.

3.2.1.4 BellSouth shall test the data portion of the Loop to ensure the continuity of the wiring for Clearwave Communications's data.

3.3 **BellSouth Provided Splitter**

3.3.1 BellSouth will select, purchase, install, and maintain a central office POTS splitter and provide Clearwave Communications access to data ports on the splitter. The splitter will route the High Frequency Spectrum on the circuit to Clearwave Communications's xDSL equipment in Clearwave Communications's collocation space. At least 30 days before making a change in splitter suppliers, BellSouth will provide Clearwave Communications with a carrier notification letter, informing Clearwave Communications of change. Clearwave Communications shall purchase ports on the splitter in increments of 8, 24, or 96 ports in Alabama, Florida, Georgia, Kentucky, Louisiana, Mississippi, North Carolina and South Carolina. Clearwave Communications shall purchase ports on the splitter in increments of 24 or 96 ports in Tennessee.

3.3.2 BellSouth will install the splitter in (i) a common area close to Clearwave Communications's collocation area, if possible; or (ii) in a BellSouth relay rack as

close to Clearwave Communications's DS0 termination point as possible. Clearwave Communications shall have access to the splitter for test purposes, regardless of where the splitter is placed in the BellSouth premises. For purposes of this section, a common area is defined as an area in the central office in which both Parties have access to a common test access point. A Termination Point is defined as the point of termination for Clearwave Communications on the main distributing frame in the central office and is not the demarcation point set forth in Attachment 4 of this Agreement. BellSouth will cross-connect the splitter data ports to a specified Clearwave Communications DS0 at such time that a Clearwave Communications end user's service is established.

### 3.4 **CLEC Provided Splitter**

3.4.1 Clearwave Communications may at its option purchase, install and maintain central office POTS splitters in its collocation arrangements. Clearwave Communications may use such splitters for access to its customers and to provide digital line subscriber services to its customers using the High Frequency Spectrum. Existing Collocation rules and procedures and the terms and conditions relating to Collocation set forth in Attachment 4-Central Office shall apply.

3.4.2 Any splitters installed by Clearwave Communications in its collocation arrangement shall comply with ANSI T1.413, Annex E, or any future ANSI splitter Standards. Clearwave Communications may install any splitters that BellSouth deploys or permits to be deployed for itself or any BellSouth affiliate.

### 3.5 **Ordering**

3.5.1 Clearwave Communications shall use BellSouth's Line Splitter Ordering Document (LSOD) to order splitters from BellSouth and to activate and deactivate DS0 Collocation Connecting Facility Assignments (CFA) for use with High Frequency Spectrum.

3.5.2 BellSouth will provide Clearwave Communications the Local Service Request (LSR) format to be used when ordering the High Frequency Spectrum.

3.5.3 BellSouth will provision High Frequency Spectrum in compliance with BellSouth's Products and Services Interval Guide available at the website at <http://www.interconnection.bellsouth.com>.

3.5.4 BellSouth will provide Clearwave Communications access to Preordering Loop Makeup (LMU) in accordance with the terms of this Agreement. BellSouth shall bill and Clearwave Communications shall pay the rates for such services, as described in Exhibit B.

### 3.6 **Maintenance and Repair**

- 3.6.1 Clearwave Communications shall have access for repair and maintenance purposes to any Loop for which it has access to the High Frequency Spectrum. If Clearwave Communications is using a BellSouth owned splitter, Clearwave Communications may access the Loop at the point where the combined voice and data signal exits the central office splitter via a bantam test jack. If Clearwave Communications provides its own splitter, it may test from the collocation space or the Termination Point.
- 3.6.2 BellSouth will be responsible for repairing voice services and the physical line between the network interface device at the customer's premises and the Termination Point. Clearwave Communications will be responsible for repairing data services. Each Party will be responsible for maintaining its own equipment.
- 3.6.3 Clearwave Communications shall inform its end users to direct data problems to Clearwave Communications, unless both voice and data services are impaired, in which event the end users should call BellSouth.
- 3.6.4 Once a Party has isolated a trouble to the other Party's portion of the Loop, the Party isolating the trouble shall notify the end user that the trouble is on the other Party's portion of the Loop.
- 3.6.5 Notwithstanding anything else to the contrary in this Agreement, when BellSouth receives a voice trouble and isolates the trouble to the physical collocation arrangement belonging to Clearwave Communications, BellSouth will notify Clearwave Communications. Clearwave Communications will provide at least one but no more than two (2) verbal connecting facility assignments (CFA) pair changes to BellSouth in an attempt to resolve the voice trouble. In the event a CFA pair change resolves the voice trouble, Clearwave Communications will provide BellSouth an LSR with the new CFA pair information within 24 hours. If the owner of the collocation space fails to resolve the trouble by providing BellSouth with the verbal CFA pair changes, BellSouth may discontinue Clearwave Communications's access to the High Frequency Spectrum on such Loop. BellSouth will not be responsible for any loss of data as a result of this action.

### 3.7 **Line Splitting**

#### 3.7.1 General

- 3.7.2 Line splitting allows a provider of data services (a "Data LEC") and a provider of voice services (a "Voice CLEC") to deliver voice and data service to End Users over the same Loop. The Voice CLEC and Data LEC may be the same or different carriers. Clearwave Communications shall provide BellSouth with a signed Letter of Authorization (LOA) between it and the Data LEC or Voice CLEC with which it desires to provision Line Splitting services, if Clearwave Communications will not provide voice and data services.

- 3.7.3 End Users currently receiving voice service from a Voice CLEC through a UNE platform (UNE-P) may be converted to Line Splitting arrangements by Clearwave Communications or its authorized agent ordering Line Splitting Service. If the CLEC wishes to provide the splitter, the UNE-P arrangement will be converted to a stand-alone UNE Loop, a UNE port, two collocation cross connects and the high frequency spectrum line activation. If BellSouth owns the splitter, the UNE-P arrangement will be converted to a stand-alone UNE Loop, port, and one collocation cross connection.
- 3.7.4 When end users on Loops using High Frequency Spectrum CO Based line sharing service are converted to Line Splitting, BellSouth will discontinue billing Clearwave Communications for the High Frequency Spectrum. BellSouth will continue to bill the Data LEC for all associated splitter charges if the Data LEC continues to use a BellSouth splitter. It is the responsibility of Clearwave Communications or its authorized agent to determine if the Loop is compatible for Line Splitting Service. Clearwave Communications or its authorized agent may use the existing Loop unless it is not compatible with the Data LEC's data service and Clearwave Communications or its authorized agent submits an LSR to BellSouth to change the Loop.
- 3.8 **Provisioning Line Splitting and Splitter Space**
- 3.8.1 The Data LEC, Voice CLEC or BellSouth may provide the splitter. When Clearwave Communications or its authorized agent owns the splitter, Line Splitting requires the following: a non-designed analog Loop from the serving wire center to the network interface device (NID) at the end user's location; a collocation cross connection connecting the Loop to the collocation space; a second collocation cross connection from the collocation space connected to a voice port; the high frequency spectrum line activation, and a splitter. The Loop and port cannot be a Loop and port combination (i.e. UNE-P), but must be individual stand-alone network elements. When BellSouth owns the splitter, Line Splitting requires the following: a non designed analog Loop from the serving wire center to the network interface device (NID) at the end user's location with CFA and splitter port assignments, and a collocation cross connection from the collocation space connected to a voice port.
- 3.8.2 An unloaded 2-wire copper Loop must serve the end user. The meet point for the Voice CLEC and the Data LEC is the point of termination on the MDF for the Data LEC's cable and pairs.
- 3.8.3 The foregoing procedures are applicable to migration to Line Splitting Service from a UNE-P arrangement, BellSouth Retail Voice Service, BellSouth High Frequency Spectrum (CO Based) Line Sharing.

- 3.8.4 For other migration scenarios to line splitting, BellSouth will work cooperatively with CLECs to develop methods and procedures to develop a process whereby a Voice CLEC and a Data LEC may provide services over the same Loop.

### **3.9 Ordering**

- 3.9.1 Clearwave Communications shall use BellSouth's Line Splitter Ordering Document (LSOD) to order splitters from BellSouth and to activate and deactivate DS0 Collocation Connecting Facility Assignments (CFA) for use with Line Splitting.
- 3.9.2 BellSouth shall provide Clearwave Communications the Local Service Request (LSR) format to be used when ordering Line Splitting service.
- 3.9.3 BellSouth will provision Line Splitting service in compliance with BellSouth's Products and Services Interval Guide available at the website at <http://www.interconnection.bellsouth.com>.
- 3.9.4 BellSouth will provide Clearwave Communications access to Preordering Loop Makeup (LMU) in accordance with the terms of this Agreement. BellSouth shall bill and Clearwave Communications shall pay the rates for such services as described in Exhibit B.
- 3.9.5 BellSouth will provide Loop modification to Clearwave Communications on an existing Loop in accordance with procedures developed in the Line Sharing Collaborative. High Frequency Spectrum (CO Based) Unbundled Loop Modification is a separate distinct service from Unbundled Loop Modification set forth in Section 2.5 of this Attachment. Procedures for High Frequency Spectrum (CO Based) Unbundled Loop Modification may be found on the web at: <HTTP://www.interconnection.bellsouth.com/html/unes.html>. Nonrecurring rates for this UNE offering are as set forth in Exhibit B of this Attachment.

### **3.10 Maintenance**

- 3.10.1 BellSouth will be responsible for repairing voice services and the physical line between the network interface device at the customer's premises and the Termination Point. Clearwave Communications will be responsible for repairing data services. Each Party will be responsible for maintaining its own equipment.
- 3.10.2 Clearwave Communications shall inform its end users to direct data problems to Clearwave Communications, unless both voice and data services are impaired, in which event the end users should call BellSouth.
- 3.10.3 Once a Party has isolated a trouble to the other Party's portion of the Loop, the Party isolating the trouble shall notify the end user that the trouble is on the other Party's portion of the Loop.

3.10.4 When BellSouth receives a voice trouble and isolates the trouble to the physical collocation arrangement belonging to owner of the collocation space, BellSouth will notify the owner of the collocation space. The owner of the collocation space will provide at least one but no more than two (2) verbal CFA pair changes to BellSouth in an attempt to resolve the voice trouble. In the event the CFA pair is changed, the owner of the collocation space will provide BellSouth an LSR with the new CFA pair information within 24 hours. If the owner of the collocation space fails to resolve the trouble by providing BellSouth with the verbal CFA pair changes, BellSouth may discontinue the owner of the collocation space access to the High Frequency Spectrum on such Loop.

3.10.5 If Clearwave Communications is not the data provider, Clearwave Communications shall indemnify, defend and hold harmless BellSouth from and against any claims, losses, actions, causes of action, suits, demands, damages, injury, and costs including reasonable attorney fees, which arise out of actions related to the data provider.

### **3.11 Remote Site High Frequency Spectrum**

3.11.1 General

3.11.2 BellSouth shall provide Clearwave Communications access to the high frequency spectrum of the local sub-loop as an unbundled network element (UNE) only where BellSouth is the voice service provider to the end user at the rates set forth in this Attachment.

3.11.3 The High Frequency Spectrum is defined as the frequency range above the voiceband on a copper sub-loop facility carrying analog circuit-switched voiceband transmissions. Access to the High Frequency Spectrum is intended to allow Clearwave Communications the ability to provide Digital Subscriber Line (xDSL) data services to the end user for whom BellSouth provides voice services. The High Frequency Spectrum shall be available for any version of xDSL complying with Spectrum Management Class 5 of ANSI T1.417, American National Standard for Telecommunications, Spectrum Management for Loop Transmission Systems. BellSouth will continue to have access to the low frequency portion of the sub-loop spectrum (from 300 Hertz to at least 3000 Hertz, and potentially up to 3400 Hertz, depending on equipment and facilities) for the purposes of providing voice service. Clearwave Communications shall only use xDSL technology that is within the PSD mask for Spectrum Management Class 5 as found in the above-mentioned document.

3.11.4 Access to the High Frequency Spectrum requires an unloaded, 2-wire (Non-Designed) copper sub-loop. An unloaded copper sub-loop has no load coils, low-pass filters, range extenders, DAMLs, or similar devices and minimal bridged taps consistent with ANSI T1.413 and T1.601.

- 3.11.5 BellSouth will provide Loop Modification to Clearwave Communications on an existing sub-loop in accordance with procedures developed in the Line Sharing Collaborative. Procedures for High Frequency Spectrum (Remote Site) Unbundled Loop Modification were developed in the Line Sharing Collaborative and may be found posted to the web at <http://www.interconnection.bellsouth.com/html/unes.html>. Nonrecurring rates for this UNE offering are as set forth in Exhibit B of this Attachment. BellSouth is not required to modify a Loop for access to the High Frequency spectrum if modification of that Loop significantly degrades BellSouth's voice service. If Clearwave Communications requests modifications on a sub-loop longer than 18,000 ft. and requested modifications significantly degrades the voice services on the Loop, Clearwave Communications shall pay for the Loop to be restored to its original state.
- 3.11.6 The High Frequency Spectrum shall only be available on sub-loops provided by BellSouth that continues to provide analog voice service directly to the end user. In the event the End User terminates its BellSouth provided voice service for any reason, or in the event BellSouth disconnects the end user's voice service pursuant to its tariffs or applicable law, and Clearwave Communications desires to continue providing xDSL service on such sub-loop, Clearwave Communications shall be required to purchase a full stand-alone sub-loop. To the extent commercially practicable, BellSouth shall give Clearwave Communications notice in a reasonable time prior to disconnect, which notice shall give Clearwave Communications an adequate opportunity to notify BellSouth of its intent to purchase such sub-loop. In those cases where BellSouth no longer provides voice service to the end user and Clearwave Communications purchases the full stand-alone sub-loop, Clearwave Communications may elect the type of sub-loop it will purchase. Clearwave Communications will pay the appropriate recurring and nonrecurring rates for such sub-loop as set forth in Exhibit B to this Attachment. In the event Clearwave Communications purchases a voice grade Loop, Clearwave Communications acknowledges that such sub-loop may not remain xDSL compatible.
- 3.11.7 Only one competitive local exchange carrier shall be permitted access to the High Frequency Spectrum of any particular sub-loop.
- 3.12 **Provisioning of High Frequency Spectrum and Splitter Space**
- 3.12.1 BellSouth will provide Clearwave Communications with access to the High Frequency Spectrum as follows:
- 3.12.1.1 To order High Frequency Spectrum on a particular sub-loop, Clearwave Communications must have a Digital Subscriber Line Access Multiplexer (DSLAM) collocated at the remote site that serves the End User of such sub-loop.



3.12.1.2 Clearwave Communications may provide its own splitters or may order splitters in a remote site once the Clearwave Communications has installed its DSLAM at that remote site. BellSouth will install splitters within thirty-six (36) calendar days of Clearwave Communications's submission of an error free Line Splitter Ordering Document (LSOD) to the BellSouth Complex Resale Support Group.

3.12.1.3 Once a splitter is installed on behalf of Clearwave Communications in a remote site in which Clearwave Communications is located, Clearwave Communications shall be entitled to order the High Frequency Spectrum on lines served out of that remote site. BellSouth will bill and Clearwave Communications shall pay applicable for High Frequency Spectrum End User activation.

### **3.13 BellSouth Owned Splitter**

3.13.1 BellSouth will select, purchase, install and maintain a splitter at the remote site. The Clearwave Communications's meet point is at the BellSouth "cross connect" point located at the Feeder Distribution Interface (FDI). Clearwave Communications will provide a cable facility to the BellSouth FDI. BellSouth will splice the Clearwave Communications's cable to BellSouth's spare binding post in the FDI and use "cross connects" to connect the Clearwave Communications's cable facility to the BellSouth splitter. The splitter will route the high frequency portion of the circuit to the Clearwave Communications's xDSL equipment in their collocation space. Access to the high frequency spectrum is not compatible with foreign exchange (FX) lines, ISDN, and other services listed in the technical section of this document.

3.13.2 The BellSouth splitter bifurcates the digital and voice band signals. The low frequency voice band portion of the circuit is routed back to the BellSouth switch. The high frequency digital traffic portion of the circuit is routed to the xDSL equipment in the Clearwave Communications's Remote Terminal (RT) collocation space and routed back to the Clearwave Communications's network. At least 30 business days before making a change in splitter suppliers, BellSouth will provide Clearwave Communications with a carrier notification letter informing Clearwave Communications of change. Clearwave Communications shall purchase ports on the splitter in increments of 24 ports.

3.13.3 BellSouth will install the splitter in (i) a common area close to Clearwave Communications's collocation area, if possible; or (ii) in a BellSouth relay rack as close to Clearwave Communications's DS0 termination point as possible. Clearwave Communications shall have access to the splitter for test purposes regardless of where the splitter is placed in the BellSouth premises. For purposes of this section, a common area is defined as an area in the remote site in which both Parties have access to a common test access point. BellSouth will cross-connect the splitter data ports to a specified Clearwave Communications DS0 at such time that a Clearwave Communications end user's service is established.

### 3.14 **CLEC Owned Splitter**

3.14.1 Clearwave Communications may at its option purchase, install and maintain splitters in its collocation arrangements. Clearwave Communications may use such splitters for access to its customers and to provide digital line subscriber services to its customers using the High Frequency Spectrum. Existing Collocation rules and procedures shall apply. Clearwave Communications will be required to activate cable pairs in no less than 8 (eight) pair increments.

3.14.2 Any splitters installed by Clearwave Communications in its collocation arrangement shall comply with ANSI T1.413, Annex E, or any future ANSI splitter Standards. Clearwave Communications may install any splitters that BellSouth deploys or permits to be deployed for itself or any BellSouth affiliate.

### 3.15 **Ordering**

3.15.1 Clearwave Communications shall use BellSouth's Remote Splitter Ordering Document (RSOD) to order and activate splitters from BellSouth or to activate CLEC owned splitters at an RT for use with High Frequency Spectrum.

3.15.2 BellSouth will provide Clearwave Communications the Local Service Request (LSR) format to be used when ordering the High Frequency Spectrum.

3.15.3 BellSouth will provision High Frequency Spectrum in compliance with BellSouth's Products and Services Interval Guide available at the website at <http://www.interconnection.bellsouth.com>.

3.15.4 BellSouth will provide Clearwave Communications access to Preordering Loop Makeup (LMU) in accordance with the terms of this Agreement. BellSouth shall bill and Clearwave Communications shall pay the rates for such services as described in Exhibit B.

3.15.5 BellSouth shall test the data portion of the sub-loop to ensure the continuity of the wiring for Clearwave Communications's data.

### 3.16 **Maintenance and Repair**

3.16.1 Clearwave Communications shall have access for repair and maintenance purposes to any sub-loop for which it has access to the High Frequency Spectrum. If Clearwave Communications is using a BellSouth owned splitter, Clearwave Communications may access the sub-loop at the point where the data signal exits. If Clearwave Communications provides its own splitter, it may test from the collocation space or the Termination Point.

3.16.2 BellSouth will be responsible for repairing voice services and the physical line between the network interface device at the customer's premises and the

Termination Point. Clearwave Communications will be responsible for repairing data services. Each Party will be responsible for maintaining its own equipment.

- 3.16.3 Clearwave Communications shall inform its end users to direct data problems to Clearwave Communications, unless both voice and data services are impaired, in which event the end users should call BellSouth.
- 3.16.4 Once a Party has isolated a trouble to the other Party's portion of the sub-loop, the Party isolating the trouble shall notify the end user that the trouble is on the other Party's portion of the sub-loop.
- 3.16.5 Notwithstanding anything else to the contrary in this Agreement, when BellSouth receives a voice trouble and isolates the trouble to the physical collocation arrangement belonging to Clearwave Communications, BellSouth will notify Clearwave Communications. Clearwave Communications will provide at least one but no more than two (2) verbal connecting facility assignments (CFA) pair changes to BellSouth in an attempt to resolve the voice trouble. In the event a CFA pair change resolves the voice trouble, Clearwave Communications will provide BellSouth an LSR with the new CFA pair information within 24 hours. If the owner of the collocation space fails to resolve the trouble by providing BellSouth with the verbal CFA pair changes, BellSouth may discontinue Clearwave Communications's access to the High Frequency Spectrum on such sub-loop. BellSouth will not be responsible for any loss of data as a result of this action.

#### **4 Local Switching**

- 4.1 BellSouth shall provide non-discriminatory access to local circuit switching capability and local tandem switching capability on an unbundled basis, except as set forth in the Sections below to Clearwave Communications for the provision of a telecommunications service. BellSouth shall provide non-discriminatory access to packet switching capability on an unbundled basis to Clearwave Communications for the provision of a telecommunications service only in the limited circumstance described below in Section 4.5.

#### **4.2 Local Circuit Switching Capability, including Tandem Switching Capability**

- 4.2.1 Local circuit switching capability is defined as: (A) line-side facilities, which include but are not limited to the connection between a Loop termination at a main distribution frame and a switch line card; (B) trunk-side facilities, which include but are not limited to the connection between trunk termination at a trunk-side cross-connect panel and a switch trunk card; (C) switching provided by remote switching modules; and (D) all features, functions, and capabilities of the switch, which include but are not limited to: (1) the basic switching function of connecting lines to lines, line to trunks, trunks to lines, and trunks to trunks, as well as the same basic capabilities made available to BellSouth's customers, such as a

telephone number, white page listings, and dial tone; and (2) all other features that the switch is capable of providing, including but not limited to customer calling, customer local area signaling service features, and Centrex, as well as any technically feasible customized routing functions provided by the switch. Any features that are not currently available but are technically feasible through the switch can be requested through the BFR/NBR process.

- 4.2.2 Notwithstanding BellSouth's general duty to unbundle local circuit switching, BellSouth shall not be required to unbundle local circuit switching for Clearwave Communications when Clearwave Communications serves an End User with four (4) or more voice-grade (DS-0) equivalents or lines served by BellSouth in one of the following MSAs: Atlanta, GA; Miami, FL; Orlando, FL; Ft. Lauderdale, FL; Charlotte-Gastonia-Rock Hill, NC; Greensboro-Winston Salem-High Point, NC; Nashville, TN; and New Orleans, LA, and BellSouth has provided non-discriminatory cost based access to the Enhanced Extended Link (EEL) throughout Density Zone 1 as determined by NECA Tariff No. 4 as in effect on January 1, 1999.
- 4.2.3 In the event that Clearwave Communications orders local circuit switching for an end user with four (4) or more DS0 equivalent lines within Density Zone 1 in an MSA listed above, BellSouth shall charge Clearwave Communications the market based rates in Exhibit B for use of the local circuit switching functionality for the affected facilities. If a market rate is not set forth in Exhibit B, such rate shall be negotiated by the Parties.
- 4.2.4 Unbundled Local Switching consists of three separate unbundled elements: Unbundled Ports, End Office Switching Functionality, and End Office Interoffice Trunk Ports.
- 4.2.5 Unbundled Local Switching combined with Common Transport and, if necessary, Tandem Switching provides to Clearwave Communications's end user local calling and the ability to presubscribe to a primary carrier for intraLATA and/or to presubscribe to a primary carrier for interLATA toll service.
- 4.2.6 Provided that Clearwave Communications purchases unbundled local switching from BellSouth and uses the BellSouth Carrier Identification Code (CIC) for its end users' Local Preferred Interexchange Carrier (LPIC) or if a BellSouth local end user selects BellSouth as its LPIC, then the Parties will consider as local any calls originated by a Clearwave Communications local end user, or originated by a BellSouth local end user and terminated to a Clearwave Communications local end user, where such calls originate and terminate in the same LATA, except for those calls originated and terminated through switched access arrangements (i.e., calls that are transported by a Party other than BellSouth). For such calls, BellSouth will charge Clearwave Communications the UNE elements for the BellSouth facilities utilized. Neither Party shall bill the other originating or terminating switched access charges for such calls. Intercarrier compensation for local calls

between BellSouth and Clearwave Communications shall be as described in BellSouth's UNE Local Call Flows set forth on BellSouth's web site.

- 4.2.7 Where Clearwave Communications purchases unbundled local switching from BellSouth but does not use the BellSouth CIC for its end users' LPIC, BellSouth will consider as local those direct dialed telephone calls that originate from a Clearwave Communications end user and terminate within the basic local calling area or within the extended local calling areas and that are dialed using 7 or 10 digits as defined and specified in Section A3 of BellSouth's General Subscriber Services Tariffs. For such local calls, BellSouth will charge Clearwave Communications the UNE elements for the BellSouth facilities utilized. Intercarrier compensation for local calls between BellSouth and Clearwave Communications shall be as described in BellSouth's UNE Local Call Flows set forth on BellSouth's web site.
- 4.2.8 For any calls that originate and terminate through switched access arrangements (i.e., calls that are transported by a party other than BellSouth), BellSouth shall bill Clearwave Communications the UNE elements for the BellSouth facilities utilized. Each Party may bill the toll provider originating or terminating switched access charges as appropriate.
- 4.2.9 **Unbundled Port Features**
- 4.2.9.1 Charges for Unbundled Port are as set forth in Exhibit B, and as specified in such exhibit, may or may not include individual features.
- 4.2.9.2 Where applicable and available, non-switch-based services may be ordered with the Unbundled Port at BellSouth's retail rates.
- 4.2.9.3 Any features that are not currently available but are technically feasible through the switch can be requested through the- BFR/NBR process.
- 4.2.9.4 BellSouth will provide to Clearwave Communications selective routing of calls to a requested Operator System platform pursuant to Section 10 of Attachment 2. Any other routing requests by Clearwave Communications will be made pursuant to the BFR/NBR Process as set forth in Attachment 11.
- 4.2.10 **Remote Call Forwarding**
- 4.2.10.1 As an option, BellSouth shall make available to Clearwave Communications an unbundled port with Remote Call Forwarding capability (URCF service). URCF service combines the functionality of unbundled local switching, tandem switching and common transport to forward calls from the URCF service telephone number (the number dialed by the calling party) to another telephone number selected by the URCF service subscriber. When ordering URCF service, Clearwave Communications will ensure that the following conditions are satisfied:

- 4.2.10.1.1 That the end user of the forward-to number (service) agrees to receive calls forwarded using the URCF service (if such end user is different from the URCF service end user);
- 4.2.10.1.2 That the forward-to number (service) is equipped with sufficient capacity to receive the volume of calls that will be generated from the URCF service;
- 4.2.10.1.3 That the URCF service will not be utilized to forward calls to another URCF or similar service; and
- 4.2.10.1.4 That the forward-to number (service) is not a public safety number (e.g. 911, fire or police number).
- 4.2.10.2 In addition to the charge for the URCF service port, BellSouth shall charge Clearwave Communications the rates set forth in Exhibit B for unbundled local switching, tandem switching, and common transport, including all associated usage incurred for calls from the URCF service telephone number (the number dialed by the calling party) to the forward- to number (service).
- 4.2.11 **Provision for Local Switching**
- 4.2.11.1 BellSouth shall perform routine testing (e.g., Mechanized Loop Tests (MLT) and test calls such as 105, 107 and 108 type calls) and fault isolation on a mutually agreed upon schedule.
- 4.2.11.2 BellSouth shall control congestion points such as those caused by radio station call-ins and network routing abnormalities. All traffic shall be restricted in a non-discriminatory manner.
- 4.2.11.3 BellSouth shall perform manual call trace and permit customer originated call trace. BellSouth shall provide Switching Service Point (SSP) capabilities and signaling software to interconnect the signaling links destined to the Signaling Transfer Point Switch (STPS). These capabilities shall adhere to the technical specifications set forth in the applicable industry standard technical references.
- 4.2.11.4 BellSouth shall provide interfaces to adjuncts through Telcordia standard interfaces. These adjuncts can include, but are not limited to, the Service Circuit Node and Automatic Call Distributors. BellSouth shall offer to Clearwave Communications all AIN triggers in connection with its SMS/SCE offering.
- 4.2.11.5 BellSouth shall provide access to SS7 Signaling Network or Multi-Frequency trunking if requested by Clearwave Communications.
- 4.2.12 **Local Switching Interfaces.**

- 4.2.12.1 Clearwave Communications shall order ports and associated interfaces compatible with the services it wishes to provide as listed in Exhibit B. BellSouth shall provide the following local switching interfaces:
  - 4.2.12.1.1 Standard Tip/Ring interface including loopstart or groundstart, on-hook signaling (e.g., for calling number, calling name and message waiting lamp);
  - 4.2.12.1.2 Coin phone signaling;
  - 4.2.12.1.3 Basic Rate Interface ISDN adhering to appropriate Telcordia Technical Requirements;
  - 4.2.12.1.4 Two-wire analog interface to PBX;
  - 4.2.12.1.5 Four-wire analog interface to PBX;
  - 4.2.12.1.6 Four-wire DS1 interface to PBX or customer provided equipment (e.g. computers and voice response systems);
  - 4.2.12.1.7 Primary Rate ISDN to PBX adhering to ANSI standards Q.931, Q.932 and appropriate Telcordia Technical Requirements;
  - 4.2.12.1.8 Switched Fractional DS1 with capabilities to configure Nx64 channels (where N = 1 to 24); and
  - 4.2.12.1.9 Loops adhering to Telcordia TR-NWT-08 and TR-NWT-303 specifications to interconnect Digital Loop Carriers.

### 4.3 **Tandem Switching**

- 4.3.1 The Tandem Switching capability Network Element is defined as: (i) trunk-connect facilities, which include, but are not limited to, the connection between trunk termination at a cross connect panel and switch trunk card; (ii) the basic switch trunk function of connecting trunks to trunks; and (iii) the functions that are centralized in the Tandem Switches (as distinguished from separate end office switches), including but not limited to call recording, the routing of calls to operator services and signaling conversion features.

#### 4.3.2 **Technical Requirements**

- 4.3.2.1 Tandem Switching shall have the same capabilities or equivalent capabilities as those described in Telcordia TR-TSY-000540 Issue 2R2, Tandem Supplement, 6/1/90. The requirements for Tandem Switching include but are not limited to the following:
  - 4.3.2.1.1 Tandem Switching shall provide signaling to establish a tandem connection;

- 4.3.2.1.2 Tandem Switching will provide screening as jointly agreed to by Clearwave Communications and BellSouth;
- 4.3.2.1.3 Tandem Switching shall provide Advanced Intelligent Network triggers supporting AIN features where such routing is not available from the originating end office switch, to the extent such Tandem switch has such capability;
- 4.3.2.1.4 Tandem Switching shall provide access to Toll Free number database;
- 4.3.2.1.5 Tandem Switching shall provide connectivity to PSAPs where 911 solutions are deployed and the tandem is used for 911; and
- 4.3.2.1.6 Where appropriate, Tandem Switching shall provide connectivity for the purpose of routing transit traffic to and from other carriers.
- 4.3.2.2 BellSouth may perform testing and fault isolation on the underlying switch that is providing Tandem Switching. Such testing shall be testing routinely performed by BellSouth. The results and reports of the testing shall be made available to Clearwave Communications.
- 4.3.2.3 BellSouth shall control congestion points and network abnormalities. All traffic will be restricted in a non-discriminatory manner.
- 4.3.2.4 Tandem Switching shall process originating toll-free traffic received from Clearwave Communications's local switch.
- 4.3.2.5 In support of AIN triggers and features, Tandem Switching shall provide SSP capabilities when these capabilities are not available from the Local Switching Network Element to the extent such Tandem Switch has such capability.
- 4.3.3 Upon Clearwave Communications's purchase of overflow trunk groups, Tandem Switching shall provide an alternate routing pattern for Clearwave Communications's traffic overflowing from direct end office high usage trunk groups.
- 4.4 **AIN Selective Carrier Routing for Operator Services, Directory Assistance and Repair Centers**
- 4.4.1 BellSouth will provide AIN Selective Carrier Routing at the request of Clearwave Communications. AIN Selective Carrier Routing will provide Clearwave Communications with the capability of routing operator calls, 0+ and 0- and 0+ NPA (Local Numbering Plan Area) (LNPA) 555-1212 directory assistance, 1+411 directory assistance and 611 repair center calls to pre-selected destinations.
- 4.4.2 Clearwave Communications shall order AIN Selective Carrier Routing through its Account Team and/or Local Contract Manager. AIN Selective Carrier Routing must first be established regionally and then on a per central office per state basis.



- 4.4.3 AIN Selective Carrier Routing is not available in DMS 10 switches.
- 4.4.4 Where AIN Selective Carrier Routing is utilized by Clearwave Communications, the routing of Clearwave Communications's end user calls shall be pursuant to information provided by Clearwave Communications and stored in BellSouth's AIN Selective Carrier Routing Service Control Point database. AIN Selective Carrier Routing shall utilize a set of Line Class Codes (LCCs) unique to a basic class of service assigned on an "as needed" basis. The same LCCs will be assigned in each central office where AIN Selective Carrier Routing is established.
- 4.4.5 Upon ordering AIN Selective Carrier Routing Regional Service, Clearwave Communications shall remit to BellSouth the Regional Service Order nonrecurring charges set forth in Exhibit B of this Attachment. There shall be a nonrecurring End Office Establishment Charge per office due at the addition of each central office where AIN Selective Carrier Routing will be utilized. Said nonrecurring charge shall be as set forth in Exhibit B of this Attachment. For each Clearwave Communications end user activated, there shall be a nonrecurring End User Establishment charge as set forth in Exhibit B of this Attachment. Clearwave Communications shall pay the AIN Selective Carrier Routing Per Query Charge set forth in Exhibit B of this Attachment.
- 4.4.6 This Regional Service Order nonrecurring charge will be non-refundable and will be paid with 1/2 due up-front with the submission of all fully completed required forms including: Regional Selective Carrier Routing (SCR) Order Request-Form A, Central Office AIN Selective Carrier Routing (SCR) Order Request - Form B, AIN\_SCR Central Office Identification Form - Form C, AIN\_SCR Routing Options Selection Form - Form D, and Routing Combinations Table - Form E. BellSouth has 30 days to respond to Clearwave Communications's fully completed firm order as a Regional Service Order. With the delivery of this firm order response to Clearwave Communications, BellSouth considers that the delivery schedule of this service commences. The remaining 1/2 of the Regional Service Order payment must be paid when at least 90% of the Central Offices listed on the original order have been turned up for the service.
- 4.4.7 The nonrecurring End Office Establishment Charge will be billed to Clearwave Communications following BellSouth's normal monthly billing cycle for this type of order.
- 4.4.8 End-User Establishment Orders will not be turned-up until the second payment is received for the Regional Service Order. The nonrecurring End-User Establishment Charges will be billed to Clearwave Communications following BellSouth's normal monthly billing cycle for this type of order.
- 4.4.9 Additionally, the AIN Selective Carrier Routing Per Query Charge will be billed to Clearwave Communications following the normal billing cycle for per query charges.

4.4.10 All other network components needed, for example, unbundled switching, unbundled local transport, etc., will be billed per contracted rates.

#### 4.5 **Packet Switching Capability**

4.5.1 The packet switching capability network element is defined as the function of routing or forwarding packets, frames, cells or other data units based on address or other routing information contained in the packets, frames, cells or other data units.

4.5.2 BellSouth shall be required to provide non-discriminatory access to unbundled packet switching capability only where each of the following conditions are satisfied:

4.5.2.1 BellSouth has deployed digital loop carrier systems, including but not limited to, integrated digital loop carrier or universal digital loop carrier systems; or has deployed any other system in which fiber optic facilities replace copper facilities in the feeder section (e.g., end office to remote terminal, pedestal or environmentally controlled vault);

4.5.2.2 There are no spare copper Loops capable of supporting the xDSL services Clearwave Communications seeks to offer;

4.5.2.3 BellSouth has not permitted Clearwave Communications to deploy a DSLAM at the remote terminal, pedestal or environmentally controlled vault or other interconnection point, nor has Clearwave Communications obtained a virtual collocation arrangement at these sub-loop interconnection points as defined by 47 CFR § 51.319 (b); and

4.5.2.4 BellSouth has deployed packet switching capability for its own use.

4.5.3 If there is a dispute as to whether BellSouth must provide Packet Switching, such dispute will be resolved according to the dispute resolution process set forth in Section 10 of the General Terms and Conditions of this Agreement incorporated herein by this reference.

### **5 Unbundled Network Element Combinations**

5.1 For purposes of this Section, references to “Currently Combined” network elements shall mean that the particular network elements requested by Clearwave Communications are in fact already combined by BellSouth in the BellSouth network. References to “Ordinarily Combined” network elements shall mean that the particular network elements requested by Clearwave Communications are not already combined by BellSouth in the location requested by Clearwave Communications but are elements that are typically combined in BellSouth’s network. References to “Not Typically Combined” network elements shall mean

that the particular network elements requested by Clearwave Communications are not elements that BellSouth combines for its use in its network.

## **5.2 Enhanced Extended Links (EELs)**

5.2.1 EELs are combinations of unbundled Loops as defined in Section 2 and unbundled dedicated transport as defined in Section 6. BellSouth shall provide Clearwave Communications with EELs where they are available.

5.2.2 EELs are intended to provide service connectivity from an end user's location through that end user's SWC to Clearwave Communications's collocation space in a BellSouth central office. The circuit must be connected to Clearwave Communications's switch for the purpose of provisioning circuit telephone exchange service to Clearwave Communications's End User customers. Clearwave Communications may connect EELs within Clearwave Communications's collocation space to other transport terminating into Clearwave Communications's switch. Clearwave Communications may connect the local loops to an unbundled local channel to form an EEL provided that the entire EEL circuit meets the criteria set forth in Section 5.3.1.3 below. Provided that the entire EEL circuit meets the criteria set forth in Section 5.3.1.3 below, the circuit may, upon Clearwave Communications's request, terminate to a CLEC's Point of Presence (POP). Clearwave Communications will provide a significant amount of local exchange service over the requested combination, as described in Section 5.3.1 et seq. below. Upon BellSouth's request, Clearwave Communications shall indicate under what local usage option Clearwave Communications seeks to qualify. Clearwave Communications shall be deemed to be providing a significant amount of local exchange service over the requested combination if one of the options listed in Section 5.3.1.1 through 5.3.1.3 is met. BellSouth shall have the right to audit Clearwave Communications's EELs as specified in Section 5.3.3 below.

## **5.3 Conversions from Special Access Service to EELs**

5.3.1 Clearwave Communications may convert existing (Currently Combined) special access services to combinations of Loop and transport network elements, whether or not Clearwave Communications self-provides its entrance facilities (or obtains entrance facilities from a third party), unless Clearwave Communications does not use the combination to provide a significant amount of local exchange service, in addition to exchange access service, to a particular customer. To the extent Clearwave Communications requests to convert any special access services to combinations of Loop and transport network elements at UNE prices, Clearwave Communications shall provide to BellSouth a certification that Clearwave Communications is providing a significant amount of local exchange service (as described in this Section) over such combinations. The certification shall also indicate under what local usage option Clearwave Communications seeks to

qualify for conversion of special access circuits. Clearwave Communications shall be deemed to be providing a significant amount of local exchange service over such combinations if one of the following options is met:

- 5.3.1.1 **Option 1:** Clearwave Communications certifies that it is the exclusive provider of an end user's local exchange service. The Loop-transport combinations must terminate at Clearwave Communications's collocation arrangement in at least one BellSouth central office. This option does not allow Loop-transport combinations to be connected to BellSouth's tariffed services. Under this option, Clearwave Communications is the end user's only local service provider, and thus is providing more than a significant amount of local exchange service. Clearwave Communications can then use the Loop-transport combinations that serve the end user to carry any type of traffic, including using them to carry 100 percent interstate access traffic; or
- 5.3.1.2 **Option 2:** Clearwave Communications certifies that it provides local exchange and exchange access service to the end user customer's premises and handles at least one third of the end user customer's local traffic measured as a percent of total end user customer local dial tone lines; and for DS1 circuits and above, at least 50 percent of the activated channels on the Loop portion of the Loop-transport combination have at least 5 percent local voice traffic individually, and the entire Loop facility has at least 10 percent local voice traffic. When a Loop-transport combination includes multiplexing, each of the individual DS1 circuits must meet this criterion. The Loop-transport combination must terminate at Clearwave Communications's collocation arrangement in at least one BellSouth central office. This option does not allow Loop-transport combinations to be connected to BellSouth tariffed services; or
- 5.3.1.3 **Option 3:** Clearwave Communications certifies that at least 50 percent of the activated channels on a circuit are used to provide originating and terminating local dial tone service and at least 50 percent of the traffic on each of these local dial tone channels is local voice traffic, and that the entire Loop facility has at least 33 percent local voice traffic. When a Loop-transport combination includes multiplexing, each of the individual DS1 circuits must meet this criterion. This option does not allow Loop-transport combinations to be connected to BellSouth's tariffed services. Under this option, collocation is not required. Clearwave Communications does not need to provide a defined portion of the end user's local service, but the active channels on any Loop-transport combination, and the entire facility, must carry the amount of local exchange traffic specified in this option.

- 5.3.2 In addition, there may be extraordinary circumstances where Clearwave Communications is providing a significant amount of local exchange service but does not qualify under any of the three options set forth in Section 5.3.1 et seq. In such case, Clearwave Communications may petition the FCC for a waiver of the local usage options set forth above. If a waiver is granted, then upon either Party's request the Parties shall amend this Agreement to the extent necessary to incorporate the terms of such waiver for such extraordinary circumstance.
- 5.3.3 BellSouth may, at its sole discretion, audit Clearwave Communications's records in order to verify compliance with the local usage option provided by Clearwave Communications pursuant to Section 5.3.1. The audit shall be conducted by a third party independent auditor, and Clearwave Communications shall be given thirty days written notice of BellSouth's intent to audit. Such audit shall occur no more than one time in a calendar year unless results of an audit find noncompliance with the significant amount of local exchange service requirement. In the event of noncompliance, Clearwave Communications shall reimburse BellSouth for the cost of the audit. If, based on the audit, Clearwave Communications is not providing a significant amount of local exchange traffic over the combinations of Loop and transport network elements, BellSouth will convert such combinations of Loop and transport network elements to special access services in accordance with BellSouth's tariffs and will bill Clearwave Communications for appropriate retroactive reimbursement. If the Parties disagree as to whether the audits indicate that Clearwave Communications is not providing a significant amount of local exchange traffic, the dispute will be resolved according to the dispute resolution process set forth in Section 10 of the General Terms and Conditions of this Agreement.
- In the event Clearwave Communications converts special access circuits to combinations of Loop and transport UNEs pursuant to the terms of this Section, Clearwave Communications shall be subject to the termination liability provisions in the applicable special access tariffs, if any.
- 5.4 Rates
- 5.4.1 Currently Combined EELs listed below in Sections 5.4.1.1-5.4.1.14 shall be billed at the nonrecurring switch-as-is charge and recurring charges for that combination as set forth in Exhibit B of this Attachment. Currently Combined EELs not listed below shall be billed at the sum of the recurring charges for the individual network elements that comprise the combination as set forth in Exhibit B of this Attachment and a nonrecurring switch-as-is charge as set forth in Exhibit B of this Attachment.
- 5.4.1.1 DS1 Interoffice Channel + DS1 Channelization + 2-wire VG Local Loop

- 5.4.1.2 DS1 Interoffice Channel + DS1 Channelization + 4-wire VG Local Loop
- 5.4.1.3 DS1 Interoffice Channel + DS1 Channelization + 2-wire ISDN Local Loop
- 5.4.1.4 DS1 Interoffice Channel + DS1 Channelization + 4-wire 56 kbps Local Loop
- 5.4.1.5 DS1 Interoffice Channel + DS1 Channelization + 4-wire 64 kbps Local Loop
- 5.4.1.6 DS1 Interoffice Channel + DS1 Local Loop
- 5.4.1.7 DS3 Interoffice Channel + DS3 Local Loop
- 5.4.1.8 STS-1 Interoffice Channel + STS-1 Local Loop
- 5.4.1.9 DS3 Interoffice Channel + DS3 Channelization + DS1 Local Loop
- 5.4.1.10 STS-1 Interoffice Channel + DS3 Channelization + DS1 Local Loop
- 5.4.1.11 2-wire VG Interoffice Channel + 2-wire VG Local Loop
- 5.4.1.12 4wire VG Interoffice Channel + 4-wire VG Local Loop
- 5.4.1.13 4-wire 56 kbps Interoffice Channel + 4-wire 56 kbps Local Loop
- 5.4.1.14 4-wire 64 kbps Interoffice Channel + 4-wire 64 kbps Local Loop
- 5.4.2 Ordinarily Combined EELs listed above shall be billed the sum of the nonrecurring and recurring charges for that combination as set forth in Exhibit B of this Attachment. Ordinarily combined EELs not listed in Sections 5.4.1.1-5.4.1.14 shall be billed the sum of the nonrecurring charges and recurring charges for the individual network elements that comprise the combination as set forth in Exhibit B of this Attachment.

5.4.3 To the extent that Clearwave Communications requests an EEL combination Not Typically Combined in the BellSouth network, the rates, terms and conditions shall be determined pursuant to the Bona Fide Request Process.

## **5.5 UNE Port/Loop Combinations**

5.5.1 Combinations of port and Loop unbundled network elements along with switching and transport unbundled network elements provide local exchange service for the origination or termination of calls. Port/ Loop combinations support the same local calling and feature requirements as described in the Unbundled Local Switching or Port section of this Attachment 2 and the ability to presubscribe to a primary carrier for intraLATA toll service and/or to presubscribe to a primary carrier for interLATA toll service.

5.5.2 Except as set forth in Section 5.5.3 below, BellSouth shall provide UNE port/Loop combinations described in Section 5.5.5 below that are Currently Combined or Ordinarily Combined in BellSouth's network at the cost-based rates in Exhibit B. Except as set forth in Section 5.5.3 below, BellSouth shall provide UNE port/Loop combinations not described in Section 5.5.5 below or Not Typically Combined Combinations in accordance with the Bona Fide Request process.

5.5.3 BellSouth is not required to provide combinations of port and Loop network elements on an unbundled basis in locations where, pursuant to FCC rules, BellSouth is not required to provide circuit switching as an unbundled network element.

5.5.3.1 BellSouth shall not be required to provide local circuit switching as an unbundled network element in density Zone 1, as defined in 47 CFR 69.123 as of January 1, 1999 of the Atlanta, GA; Miami, FL; Orlando, FL; Ft. Lauderdale, FL; Charlotte-Gastonia-Rock Hill, NC; Greensboro-Winston Salem-High Point, NC; Nashville, TN; and New Orleans, LA, MSAs to Clearwave Communications if Clearwave Communications's customer has 4 or more DS0 equivalent lines.

5.5.3.2 Notwithstanding the foregoing, BellSouth shall provide combinations of port and Loop network elements on an unbundled basis where, pursuant to FCC rules, BellSouth is not required to provide local circuit switching as an unbundled network element and shall do so at the market rates in Exhibit B. If a market rate is not set forth in Exhibit B for a UNE port/Loop combination, such rate shall be negotiated by the Parties.

5.5.4 BellSouth shall make 911 updates in the BellSouth 911 database for Clearwave Communications's UNE port/Loop combinations. BellSouth will not bill

Clearwave Communications for 911 surcharges. Clearwave Communications is responsible for paying all 911 surcharges to the applicable governmental agency.

#### 5.5.5 Combination Offerings

- 5.5.5.1 2-wire voice grade port, voice grade Loop, unbundled end office switching, unbundled end office trunk port, common transport per mile per MOU, common transport facilities termination, tandem switching, and tandem trunk port.
- 5.5.5.2 2-wire voice grade Coin port, voice grade Loop, unbundled end office switching, unbundled end office trunk port, common transport per mile per MOU, common transport facilities termination, tandem switching, and tandem trunk port.
- 5.5.5.3 2-wire voice grade DID port, voice grade Loop, unbundled end office switching, unbundled end office trunk port, common transport per mile per MOU, common transport facilities termination, tandem switching, and tandem trunk port.
- 5.5.5.4 2-wire CENTREX port, voice grade Loop, CENTREX intercom functionality, unbundled end office switching, unbundled end office trunk port, common transport per mile per MOU, common transport facilities termination, tandem switching, and tandem trunk port.
- 5.5.5.5 2-wire ISDN Basic Rate Interface, voice grade Loop, unbundled end office switching, unbundled end office trunk port, common transport per mile per MOU, common transport facilities termination, tandem switching, and tandem trunk port.
- 5.5.5.6 4-wire ISDN Primary Rate Interface, DS1 Loop, unbundled end office switching, unbundled end office trunk port, common transport per mile per MOU, common transport facilities termination, tandem switching, and tandem trunk port.
- 5.5.5.7 4-wire DS1 Trunk port, DS1 Loop, unbundled end office switching, unbundled end office trunk port, common transport per mile per MOU, common transport facilities termination, tandem switching, and tandem trunk port.
- 5.5.5.8 4-wire DS1 Loop with normal serving wire center channelization interface, 2-wire voice grade ports (PBX), 2-wire DID ports, unbundled end office switching, unbundled end office trunk port, common transport per mile per MOU, common transport facilities termination, tandem switching, and tandem trunk port.

#### 5.6 Other UNE Combinations

- 5.6.1 BellSouth shall provide other Currently Combined and Ordinarily Combined and Not Typically Combined UNE Combinations to Clearwave Communications in addition to those specifically referenced in this Section 5 above, where available. Such combinations shall not be connected to BellSouth tariffed services. To the extent Clearwave Communications requests a combination for which BellSouth does not have methods and procedures in place to provide such combination, rates



and/or methods and procedures for such combination will be developed pursuant to the BFR/NBR process.

5.6.2 Rates

5.6.3 The rates for Ordinarily Combined UNE Combinations provisioned pursuant to this Section 5.6 shall be the sum of the recurring rates and nonrecurring rates for the individual network elements as set forth in Exhibit B of this Attachment. The rates for Currently Combined UNE Combinations provisioned pursuant to this Section 5.6 shall be the sum of the recurring rates for the individual network elements as set forth in Exhibit B, in addition to a nonrecurring charge set forth in Exhibit B. To the extent Clearwave Communications requests a Not Typically Combined Combination pursuant to this Section 5.6, or to the extent Clearwave Communications requests any combination for which BellSouth has not developed methods and procedures to provide such combination, rates and/or methods and procedures for such combination shall be established pursuant to the BFR/NBR process.

**6 Transport, Channelization and Dark Fiber**

**6.1 Transport**

6.1.1 BellSouth shall provide nondiscriminatory access, in accordance with FCC Rule 51.311 and Section 251(c)(3) of the Act, to interoffice transmission facilities on an unbundled basis to Clearwave Communications for the provision of a telecommunications service. Interoffice transmission facility network elements include:

6.1.1.1 Dedicated transport, defined as BellSouth's transmission facilities, is dedicated to a particular customer or carrier that provides telecommunications between wire centers or switches owned by BellSouth, or between wire centers and switches owned by BellSouth and Clearwave Communications.

6.1.1.2 Dark Fiber transport, defined as BellSouth's optical transmission facilities without attached signal regeneration, multiplexing, aggregation or other electronics;

6.1.1.3 Common (Shared) transport, defined as transmission facilities shared by more than one carrier, including BellSouth, between end office switches, between end office switches and tandem switches, and between tandem switches, in BellSouth's network. Where BellSouth Network Elements are connected by intraoffice wiring, such wiring is provided as part of the Network Element and is not Common (Shared) Transport.

6.1.2 BellSouth shall:

6.1.2.1 Provide Clearwave Communications exclusive use of interoffice transmission facilities dedicated to a particular customer or carrier, or shared use of the

features, functions, and capabilities of interoffice transmission facilities shared by more than one customer or carrier;

- 6.1.2.2 Provide all technically feasible transmission facilities, features, functions, and capabilities of the transport facility for the provision of telecommunications services;
- 6.1.2.3 Permit, to the extent technically feasible, Clearwave Communications to connect such interoffice facilities to equipment designated by Clearwave Communications, including but not limited to, Clearwave Communications's collocated facilities; and
- 6.1.2.4 Permit, to the extent technically feasible, Clearwave Communications to obtain the functionality provided by BellSouth's digital cross-connect systems.
- 6.1.3 Technical Requirements of Common (Shared) Transport
  - 6.1.3.1 Common (Shared) Transport provided on DS1, DS3, and STS-1 circuits shall at a minimum meet the performance, availability, jitter, and delay requirements specified for Central Office to Central Office (CO to CO) connections in the applicable industry standards.
  - 6.1.3.2 BellSouth shall be responsible for the engineering, provisioning, and maintenance of the underlying equipment and facilities that are used to provide Common (Shared) Transport.
  - 6.1.3.3 At a minimum, Common (Shared) Transport shall meet all of the requirements set forth in the applicable industry standards.

## 6.2 **Dedicated Transport**

- 6.2.1 Dedicated Transport is composed of the following Unbundled Network Elements:
  - 6.2.1.1 Unbundled Local Channel, defined as the dedicated transmission path between Clearwave Communications's Point of Presence (POP) and Clearwave Communications's collocation space in the BellSouth Serving Wire Center for Clearwave Communications's POP, and
  - 6.2.1.2 Unbundled Interoffice Channel, defined as the dedicated transmission path that provides telecommunication between BellSouth's Serving Wire Centers' collocations.
  - 6.2.1.3 BellSouth shall offer Dedicated Transport in each of the following ways:
    - 6.2.1.3.1 As capacity on a shared UNE facility.
    - 6.2.1.3.2 As a circuit (e.g., DS0, DS1, DS3) dedicated to Clearwave Communications.

- 6.2.1.4 Dedicated Transport may be provided over facilities such as optical fiber, copper twisted pair, and coaxial cable, and shall include transmission equipment such as line terminating equipment, amplifiers, and regenerators.
- 6.2.2 Technical Requirements
- 6.2.2.1 The entire designated transmission service (e.g., DS0, DS1, DS3) shall be dedicated to Clearwave Communications designated traffic.
- 6.2.2.2 For DS1 or DS3 circuits, Dedicated Transport shall at a minimum meet the performance, availability, jitter, and delay requirements specified for Customer Interface to Central Office (CI to CO) connections in the applicable industry standards.
- 6.2.2.3 BellSouth shall offer the following interface transmission rates for Dedicated Transport:
- 6.2.2.3.1 DS0 Equivalent;
- 6.2.2.3.2 DS1;
- 6.2.2.3.3 DS3; and
- 6.2.2.3.4 SDH (Synchronous Digital Hierarchy) Standard interface rates are in accordance with International Telecommunications Union (ITU) Recommendation G.707 and Plesiochronous Digital Hierarchy (PDH) rates per ITU Recommendation G.704.
- 6.2.2.4 BellSouth shall design Dedicated Transport according to its network infrastructure. Clearwave Communications shall specify the termination points for Dedicated Transport.
- 6.2.2.5 At a minimum, Dedicated Transport shall meet each of the requirements set forth in the applicable industry technical references.
- 6.2.2.6 BellSouth Technical References:
- 6.2.2.6.1 TR-TSY-000191 Alarm Indication Signals Requirements and Objectives, Issue 1, May 1986.
- 6.2.2.6.2 TR 73501 LightGate<sup>®</sup> Service Interface and Performance Specifications, Issue D, June 1995.
- 6.2.2.6.3 TR 73525 MegaLink<sup>®</sup> Service, MegaLink Channel Service and MegaLink Plus Service Interface and Performance Specifications, Issue C, May 1996.
- 6.3 **Unbundled Channelization (Multiplexing)**

- 6.3.1 Unbundled Channelization (UC) provides the optional multiplexing capability that will allow a DS1 (1.544 Mbps) or DS3 (44.736 Mbps) or STS-1 (51.84 Mbps) Unbundled Network Element (UNE) or collocation cross-connect to be multiplexed or channelized at a BellSouth central office. Channelization can be accomplished through the use of a multiplexer or a digital cross-connect system at the discretion of BellSouth. Once UC has been installed, Clearwave Communications may request channel activation on an as-needed basis and BellSouth shall connect the requested facilities via Central Office Channel Interfaces (COCI). The COCI must be compatible with the lower capacity facility and ordered with the lower capacity facility. This service is available as defined in NECA 4.
- 6.3.2 BellSouth shall make available the following channelization systems and interfaces:
- 6.3.2.1 DS1 Channelization System: channelizes a DS1 signal into a maximum of 24 DS0s. The following Central Office Channel Interfaces (COCI) are available: Voice Grade, Digital Data and ISDN.
- 6.3.2.2 DS3 Channelization System: channelizes a DS3 signal into a maximum of 28 DS1s. A DS1 COCI is available with this system.
- 6.3.2.3 STS-1 Channelization System: channelizes a STS-1 signal into a maximum of 28 DS1s. A DS1 COCI is available with this system.
- 6.3.2.4 AMI and B8ZS line coding with either Super Frame (SF) and Extended Super Frame (ESF) framing formats will be supported as an optional feature on DS1 facilities.
- 6.3.3 Technical Requirements
- 6.3.3.1 In order to assure proper operation with BellSouth provided central office multiplexing functionality, Clearwave Communications's channelization equipment must adhere strictly to form and protocol standards. Clearwave Communications must also adhere to such applicable industry standards for the multiplex channel bank, for voice frequency encoding, for various signaling schemes, and for sub rate digital access.
- 6.3.3.2 TR 73501 LightGate<sup>®</sup> Service Interface and Performance Specifications, Issue D, June 1995

## 6.4 **Dark Fiber Transport**

- 6.4.1 Dark Fiber Transport is an unused optical transmission facility without attached signal regeneration, multiplexing, aggregation or other electronics. Dark Fiber Transport is offered in two configurations: Interoffice Channel, between

Clearwave Communications's collocation arrangement within the POP serving wire center and the end user service wire center and Local Channel, from Clearwave Communications's POP to Clearwave Communications's collocation arrangement in the POP serving wire center. It may be strands of optical fiber existing in aerial or underground structure. BellSouth will not provide line terminating elements, regeneration or other electronics necessary for Clearwave Communications to utilize Dark Fiber Transport.

#### 6.4.2 Requirements

6.4.2.1 BellSouth shall make available Dark Fiber Transport where it exists in BellSouth's network and where, as a result of future building or deployment, it becomes available. Dark Fiber Transport will not be deemed available if (1) it is used by BellSouth for maintenance and repair purposes, (2) it is designated for use pursuant to a firm order placed by another customer, (3) it is restricted for use by all carriers, including BellSouth, because of transmission problems or because it is scheduled for removal due to documented changes to roads and infrastructure, or (4) BellSouth has plans to use the fiber within a two-year planning period. BellSouth is not required to place fibers for Dark Fiber Transport if there are none available.

6.4.2.2 Clearwave Communications is solely responsible for testing the quality of the Dark Fiber Transport to determine its usability and performance specifications.

6.4.2.3 BellSouth shall use its best efforts to provide to Clearwave Communications information regarding the location, availability and performance of Dark Fiber Transport within ten (10) business days after receiving a request from Clearwave Communications. Within such time period, BellSouth shall send written confirmation of availability of the Dark Fiber Transport.

6.4.2.4 If the requested Dark Fiber Transport is available, BellSouth shall use its commercially reasonable efforts to provision the Dark Fiber Transport to Clearwave Communications within twenty (20) business days after Clearwave Communications submits a valid, error free LSR. Provisioning includes identification of appropriate connection points (e.g., Light Guide Interconnection (LGX)) to enable Clearwave Communications to connect Clearwave Communications provided transmission media (e.g., optical fiber) or equipment to the Dark Fiber Transport.

### 7 **BellSouth Switched Access (SWA) 8XX Toll Free Dialing Ten Digit Screening Service**

7.1 The BellSouth SWA 8XX Toll Free Dialing Ten Digit Screening Service database (8XX SCP Database) is a Signaling control Point (SCP) that contains customer record information and the functionality to provide call-handling instructions for 8XX calls. The 8XX SCP IN software stores data downloaded from the national

SMS/8XX database and provides the routing instructions in response to queries from the Switching Service Point (SSP) or tandem. The BellSouth SWA 8XX Toll Free Dialing Ten Digit Screening Service (8XX TFD Service) utilizes the 8XX SCP Database to provide identification and routing of the 8XX calls, based on the ten digits dialed. At Clearwave Communications's option, 8XX TFD Service is provided with or without POTS number delivery, dialing number delivery, and other optional complex features as selected by Clearwave Communications.

- 7.2 The 8XX SCP Database is designated to receive and respond to queries using the ANSI Specification of Signaling System Seven (SS7) protocol.

## **8 Line Information Database (LIDB)**

- 8.1 The Line Information Database (LIDB) is a transaction-oriented database accessible through Common Channel Signaling (CCS) networks. For access to LIDB, Clearwave Communications must purchase appropriate signaling links pursuant to Section 9 of this Attachment. LIDB contains records associated with end user Line Numbers and Special Billing Numbers. LIDB accepts queries from other Network Elements and provides appropriate responses. The query originator need not be the owner of LIDB data. LIDB queries include functions such as screening billed numbers that provides the ability to accept Collect or Third Number Billing calls and validation of Telephone Line Number based non-proprietary calling cards. The interface for the LIDB functionality is the interface between BellSouth's CCS network and other CCS networks. LIDB also interfaces to administrative systems.
- 8.2 Technical Requirements
- 8.2.1 BellSouth will offer to Clearwave Communications any additional capabilities that are developed for LIDB during the life of this Agreement.
- 8.2.2 BellSouth shall process Clearwave Communications's customer records in LIDB at least at parity with BellSouth customer records, with respect to other LIDB functions. BellSouth shall indicate to Clearwave Communications what additional functions (if any) are performed by LIDB in the BellSouth network.
- 8.2.3 Within two (2) weeks after a request by Clearwave Communications, BellSouth shall provide Clearwave Communications with a list of the customer data items, which Clearwave Communications would have to provide in order to support each required LIDB function. The list shall indicate which data items are essential to LIDB function and which are required only to support certain services. For each data item, the list shall show the data formats, the acceptable values of the data item and the meaning of those values.

- 8.2.4 BellSouth shall provide LIDB systems for which operating deficiencies that would result in calls being blocked shall not exceed 30 minutes per year.
- 8.2.5 BellSouth shall provide LIDB systems for which operating deficiencies that would not result in calls being blocked shall not exceed 12 hours per year.
- 8.2.6 BellSouth shall provide LIDB systems for which the LIDB function shall be in overload no more than 12 hours per year.
- 8.2.7 All additions, updates and deletions of Clearwave Communications data to the LIDB shall be solely at the direction of Clearwave Communications. Such direction from Clearwave Communications will not be required where the addition, update or deletion is necessary to perform standard fraud control measures (e.g., calling card auto-deactivation).
- 8.2.8 BellSouth shall provide priority updates to LIDB for Clearwave Communications data upon Clearwave Communications's request (e.g., to support fraud detection), via password-protected telephone card, facsimile, or electronic mail within one hour of notice from the established BellSouth contact.
- 8.2.9 BellSouth shall provide LIDB systems such that no more than 0.01% of Clearwave Communications customer records will be missing from LIDB, as measured by Clearwave Communications audits. BellSouth will audit Clearwave Communications records in LIDB against DBAS to identify record mismatches and provide this data to a designated Clearwave Communications contact person to resolve the status of the records and BellSouth will update system appropriately. BellSouth will refer record of mis-matches to Clearwave Communications within one business day of audit. Once reconciled records are received back from Clearwave Communications, BellSouth will update LIDB the same business day if less than 500 records are received before 1:00PM Central Time. If more than 500 records are received, BellSouth will contact Clearwave Communications to negotiate a time frame for the updates, not to exceed three business days.
- 8.2.10 BellSouth shall perform backup and recovery of all of Clearwave Communications's data in LIDB including sending to LIDB all changes made since the date of the most recent backup copy, in at least the same time frame BellSouth performs backup and recovery of BellSouth data in LIDB for itself. Currently, BellSouth performs backups of the LIDB for itself on a weekly basis; and when a new software release is scheduled, a backup is performed prior to loading the new release.
- 8.2.11 BellSouth shall provide Clearwave Communications with LIDB reports of data which are missing or contain errors, as well as any misrouted errors, within a reasonable time period as negotiated between Clearwave Communications and BellSouth.

- 8.2.12 BellSouth shall prevent any access to or use of Clearwave Communications data in LIDB by BellSouth personnel that are outside of established administrative and fraud control personnel, or by any other Party that is not authorized by Clearwave Communications in writing.
- 8.2.13 BellSouth shall provide Clearwave Communications performance of the LIDB Data Screening function, which allows a LIDB to completely or partially deny specific query originators access to LIDB data owned by specific data owners, for Customer Data that is part of an NPA-NXX or RAO-0/1XX wholly or partially owned by Clearwave Communications at least at parity with BellSouth Customer Data. BellSouth shall obtain from Clearwave Communications the screening information associated with LIDB Data Screening of Clearwave Communications data in accordance with this requirement. BellSouth currently does not have LIDB Data Screening capabilities. When such capability is available, BellSouth shall offer it to Clearwave Communications under the BFR/NBR process as set forth in Attachment 11.
- 8.2.14 BellSouth shall accept queries to LIDB associated with Clearwave Communications customer records and shall return responses in accordance with industry standards.
- 8.2.15 BellSouth shall provide mean processing time at the LIDB within 0.50 seconds under normal conditions as defined in industry standards.
- 8.2.16 BellSouth shall provide processing time at the LIDB within 1 second for 99% of all messages under normal conditions as defined in industry standards.
- 8.3 Interface Requirements
- 8.3.1 BellSouth shall offer LIDB in accordance with the requirements of this subsection.
- 8.3.2 The interface to LIDB shall be in accordance with the technical references contained within.
- 8.3.3 The CCS interface to LIDB shall be the standard interface described herein.
- 8.3.4 The LIDB Data Base interpretation of the ANSI-TCAP messages shall comply with the technical reference herein. Global Title Translation shall be maintained in the signaling network in order to support signaling network routing to the LIDB.
- 8.3.5 The application of the LIDB rates contained in Exhibit B to this Attachment will be based on a Percent CLEC LIDB Usage (PCLU) factor. Clearwave Communications shall provide BellSouth a PCLU. The PCLU will be applied to determine the percentage of total LIDB usage to be billed to the other Party at local rates. Clearwave Communications shall update its PCLU on the first of January, April, July and October and shall send it to BellSouth to be received no later than thirty (30) calendar days after the first of each such month based on local



usage for the past three months ending the last day of December, March, June and September, respectively. Requirements associated with PCLU calculation and reporting shall be as set forth in BellSouth's Jurisdictional Factors Reporting Guide, as it is amended from time to time.

## **9 Signaling**

9.1 BellSouth shall offer access to signaling and access to BellSouth's signaling databases subject to compatibility testing and at the rates set forth in this Attachment. BellSouth may provide mediated access to BellSouth signaling systems and databases. Available signaling elements include signaling links, signal transfer points and service control points. Signaling functionality will be available with both A-link and B-link connectivity.

### **9.2 Signaling Link Transport**

9.2.1 Signaling Link Transport is a set of two or four dedicated 56 kbps transmission paths between Clearwave Communications-designated Signaling Points of Interconnection that provide appropriate physical diversity.

9.2.2 Technical Requirements

9.2.3 Signaling Link Transport shall consist of full duplex mode 56 kbps transmission paths and shall perform in the following two ways:

9.2.3.1 As an "A-link" Signaling Link Transport is a connection between a switch or SCP and a home Signaling Transfer Point switch pair; and

9.2.3.2 As a "B-link" Signaling Link Transport is a connection between two Signaling Transfer Point switch pairs in different company networks (e.g., between two Signaling Transfer Point switch pairs for two CLECs).

9.2.4 Signaling Link Transport shall consist of two or more signaling link layers as follows:

9.2.4.1 An A-link layer shall consist of two links.

9.2.4.2 A B-link layer shall consist of four links.

9.2.4.3 A signaling link layer shall satisfy interoffice and intraoffice diversity of facilities and equipment, such that:

9.2.4.4 No single failure of facilities or equipment causes the failure of both links in an A-link layer (i.e., the links should be provided on a minimum of two separate physical paths end-to-end); and

- 9.2.4.5 No two concurrent failures of facilities or equipment shall cause the failure of all four links in a B-link layer (i.e., the links should be provided on a minimum of three separate physical paths end-to-end).
- 9.2.5 Interface Requirements
- 9.2.5.1 There shall be a DS1 (1.544 Mbps) interface at Clearwave Communications's designated SPOIs. Each 56 kbps transmission path shall appear as a DS0 channel within the DS1 interface.
- 9.3 **Signaling Transfer Points (STPs)**
- 9.3.1 A Signaling Transfer Point is a signaling network function that includes all of the capabilities provided by the signaling transfer point switches (STPs) and their associated signaling links that enables the exchange of SS7 messages among and between switching elements, database elements and signaling transfer point switches.
- 9.3.2 Technical Requirements
- 9.3.2.1 Signaling Transfer Points shall provide access to BellSouth Local Switching or Tandem Switching and to BellSouth Service Control Points/Databases connected to BellSouth SS7 network. Signaling Transfer Points also provide access to third-party local or tandem switching and Third-party-provided Signaling Transfer Points.
- 9.3.2.2 The connectivity provided by Signaling Transfer Points shall fully support the functions of all other Network Elements connected to the BellSouth SS7 network. This includes the use of the BellSouth SS7 network to convey messages that neither originate nor terminate at a signaling end point directly connected to the BellSouth SS7 network (i.e., transit messages). When the BellSouth SS7 network is used to convey transit messages, there shall be no alteration of the Integrated Services Digital Network User Part or Transaction Capabilities Application Part (TCAP) user data that constitutes the content of the message.
- 9.3.2.3 If a BellSouth tandem switch routes traffic, based on dialed or translated digits, on SS7 trunks between a Clearwave Communications local switch and third party local switch, the BellSouth SS7 network shall convey the TCAP messages that are necessary to provide Call Management features (Automatic Callback, Automatic Recall, and Screening List Editing) between Clearwave Communications local STPs and the STPs that provide connectivity with the third party local switch, even if the third party local switch is not directly connected to BellSouth STPs.
- 9.3.2.4 STPs shall provide all functions of the SCCP necessary for Class 0 (basic connectionless) service as defined in Telcordia ANSI Interconnection Requirements. This includes Global Title Translation (GTT) and SCCP Management procedures, as specified in ANSI T1.112.4. Where the destination

signaling point is a Clearwave Communications or third party local or tandem switching system directly connected to BellSouth SS7 network, BellSouth shall perform final GTT of messages to the destination and SCCP Subsystem Management of the destination. In all other cases, BellSouth shall perform intermediate GTT of messages to a gateway pair of STPs in an SS7 network connected with BellSouth SS7 network and shall not perform SCCP Subsystem Management of the destination. If BellSouth performs final GTT to a Clearwave Communications database, then Clearwave Communications agrees to provide BellSouth with the Destination Point Code for Clearwave Communications database.

9.3.2.5 STPs shall provide all functions of the OMAP as specified in applicable industry standard technical references, which may include, where available in BellSouth's network, MTP Routing Verification Test (MRVT) and SCCP Routing Verification Test (SRVT).

9.3.2.6 Where the destination signaling point is a BellSouth local or tandem switching system or database, or is a Clearwave Communications or third party local or tandem switching system directly connected to the BellSouth SS7 network, STPs shall perform MRVT and SRVT to the destination signaling point. In all other cases, STPs shall perform MRVT and SRVT to a gateway pair of STPs in an SS7 network connected with the BellSouth SS7 network. This requirement may be superseded by the specifications for Internetwork MRVT and SRVT when these become approved ANSI standards and available capabilities of BellSouth STPs.

#### 9.4 **SS7 Advanced Intelligent Network (AIN) Access**

9.4.1 When technically feasible and upon request by Clearwave Communications, SS7 AIN Access shall be made available in association with switching. SS7 AIN Access is the provisioning of AIN 0.1 triggers in an equipped BellSouth local switch and interconnection of the BellSouth SS7 network with Clearwave Communications's SS7 network to exchange TCAP queries and responses with a Clearwave Communications SCP.

9.4.2 SS7 AIN Access shall provide Clearwave Communications SCP access to an equipped BellSouth local switch via interconnection of BellSouth's SS7 and Clearwave Communications SS7 Networks. BellSouth shall offer SS7 AIN Access through its STPs. If BellSouth requires a mediation device on any part of its network specific to this form of access, BellSouth must route its messages in the same manner. The interconnection arrangement shall result in the BellSouth local switch recognizing the Clearwave Communications SCP as at least at parity with BellSouth's SCPs in terms of interfaces, performance and capabilities.

9.4.3 Interface Requirements

- 9.4.3.1 BellSouth shall provide the following STP options to connect Clearwave Communications or Clearwave Communications-designated local switching systems to the BellSouth SS7 network:
- 9.4.3.1.1 An A-link interface from Clearwave Communications local switching systems; and,
  - 9.4.3.1.2 A B-link interface from Clearwave Communications local STPs.
- 9.4.3.2 Each type of interface shall be provided by one or more layers of signaling links.
- 9.4.3.3 The Signaling Point of Interconnection for each link shall be located at a cross-connect element in the Central Office (CO) where the BellSouth STP is located. There shall be a DS1 or higher rate transport interface at each of the SPOIs. Each signaling link shall appear as a DS0 channel within the DS1 or higher rate interface.
- 9.4.3.4 BellSouth shall provide intraoffice diversity between the Signaling Point of Interconnection and BellSouth STPs so that no single failure of intraoffice facilities or equipment shall cause the failure of both B-links in a layer connecting to a BellSouth STP.
- 9.4.3.5 STPs shall provide all functions of the MTP as defined in the applicable industry standard technical references.
- 9.4.4 Message Screening
- 9.4.4.1 BellSouth shall set message screening parameters so as to accept valid messages from Clearwave Communications local or tandem switching systems destined to any signaling point within BellSouth's SS7 network where the Clearwave Communications switching system has a valid signaling relationship.
  - 9.4.4.2 BellSouth shall set message screening parameters so as to pass valid messages from Clearwave Communications local or tandem switching systems destined to any signaling point or network accessed through BellSouth's SS7 network where the Clearwave Communications switching system has a valid signaling relationship.
  - 9.4.4.3 BellSouth shall set message screening parameters so as to accept and pass/send valid messages destined to and from Clearwave Communications from any signaling point or network interconnected through BellSouth's SS7 network where the Clearwave Communications SCP has a valid signaling relationship.
- 9.5 **Service Control Points/Databases**
- 9.5.1 Call Related Databases provide the storage of, access to, and manipulation of information required to offer a particular service and/or capability. BellSouth shall provide access to the following Databases: Local Number Portability, LIDB, Toll Free Number Database, Automatic Location Identification/Data Management

System, and Calling Name Database. BellSouth also provides access to Service Creation Environment and Service Management System (SCE/SMS) application databases and Directory Assistance.

- 9.5.2 A Service Control Point (SCP) is deployed in a SS7 network that executes service application logic in response to SS7 queries sent to it by a switching system also connected to the SS7 network. Service Management Systems provide operational interfaces to allow for provisioning, administration and maintenance of subscriber data and service application data stored in SCPs.
- 9.5.3 Technical Requirements for SCPs/Databases
- 9.5.3.1 BellSouth shall provide physical access to SCPs through the SS7 network and protocols with TCAP as the application layer protocol.
- 9.5.3.2 BellSouth shall provide physical interconnection to databases via industry standard interfaces and protocols (e.g. SS7, ISDN and X.25).
- 9.5.3.3 The reliability of interconnection options shall be consistent with requirements for diversity and survivability.

## 9.6 **Local Number Portability Database**

- 9.6.1 The Permanent Number Portability (PNP) database supplies routing numbers for calls involving numbers that have been ported from one local service provider to another. BellSouth agrees to provide access to the PNP database at rates, terms and conditions as set forth by BellSouth and in accordance with an effective FCC or Commission directive.

## 9.7 **SS7 Network Interconnection**

- 9.7.1 SS7 Network Interconnection is the interconnection of Clearwave Communications local signaling transfer point switches or Clearwave Communications local or tandem switching systems with BellSouth signaling transfer point switches. This interconnection provides connectivity that enables the exchange of SS7 messages among BellSouth switching systems and databases, Clearwave Communications local or tandem switching systems, and other third-party switching systems directly connected to the BellSouth SS7 network.
- 9.7.2 The connectivity provided by SS7 Network Interconnection shall fully support the functions of BellSouth switching systems and databases and Clearwave Communications or other third-party switching systems with A-link access to the BellSouth SS7 network.
- 9.7.3 If traffic is routed based on dialed or translated digits between a Clearwave Communications local switching system and a BellSouth or other third-party local switching system, either directly or via a BellSouth tandem switching system, then

it is a requirement that the BellSouth SS7 network convey via SS7 Network Interconnection the TCAP messages that are necessary to provide Call Management services (Automatic Callback, Automatic Recall, and Screening List Editing) between the Clearwave Communications local signaling transfer point switches and BellSouth or other third-party local switch.

- 9.7.4 SS7 Network Interconnection shall provide:
  - 9.7.4.1 Signaling Data Link functions, as specified in ANSI T1.111.2;
  - 9.7.4.2 Signaling Link functions, as specified in ANSI T1.111.3; and
  - 9.7.4.3 Signaling Network Management functions, as specified in ANSI T1.111.4.
- 9.7.5 SS7 Network Interconnection shall provide all functions of the SCCP necessary for Class 0 (basic connectionless) service as specified in ANSI T1.112. This includes Global Title Translation (GTT) and SCCP Management procedures as specified in ANSI T1.112.4. Where the destination signaling point is a BellSouth switching system or DB, or is another third-party local or tandem switching system directly connected to the BellSouth SS7 network, SS7 Network Interconnection shall include final GTT of messages to the destination and SCCP Subsystem Management of the destination. Where the destination signaling point is a Clearwave Communications local or tandem switching system, SS7 Network Interconnection shall include intermediate GTT of messages to a gateway pair of Clearwave Communications local STPs and shall not include SCCP Subsystem Management of the destination.
- 9.7.6 SS7 Network Interconnection shall provide all functions of the Integrated Services Digital Network User Part as specified in ANSI T1.113.
- 9.7.7 SS7 Network Interconnection shall provide all functions of the TCAP as specified in ANSI T1.114.
- 9.7.8 If Internetwork MRVT and SRVT become approved ANSI standards and available capabilities of BellSouth STPs, SS7 Network Interconnection may provide these functions of the OMAP.
- 9.7.9 Interface Requirements
  - 9.7.9.1 The following SS7 Network Interconnection interface options are available to connect Clearwave Communications or Clearwave Communications-designated local or tandem switching systems or signaling transfer point switches to the BellSouth SS7 network:
    - 9.7.9.1.1 A-link interface from Clearwave Communications local or tandem switching systems; and

- 9.7.9.1.2 B-link interface from Clearwave Communications STPs.
- 9.7.9.2 The Signaling Point of Interconnection for each link shall be located at a cross-connect element in the central office where the BellSouth STP is located. There shall be a DS1 or higher rate transport interface at each of the Signaling Points of interconnection. Each signaling link shall appear as a DS0 channel within the DS1 or higher rate interface.
- 9.7.9.3 BellSouth shall provide intraoffice diversity between the Signaling Points of Interconnection and the BellSouth STP, so that no single failure of intraoffice facilities or equipment shall cause the failure of both B-links in a layer connecting to a BellSouth STP.
- 9.7.9.4 The protocol interface requirements for SS7 Network Interconnection include the MTP, ISDNUP, SCCP, and TCAP. These protocol interfaces shall conform to the applicable industry standard technical references.
- 9.7.9.5 BellSouth shall set message screening parameters to accept messages from Clearwave Communications local or tandem switching systems destined to any signaling point in the BellSouth SS7 network with which the Clearwave Communications switching system has a valid signaling relationship.

## **10 Operator Services (Operator Call Processing and Directory Assistance)**

- 10.1 Operator Call Processing (OCP) provides: (1) operator handling for call completion (for example, collect, third number billing, and manual calling-card calls); (2) operator or automated assistance for billing after the end user has dialed the called number (for example, calling card calls); and (3) special services including but not limited to Busy Line Verification and Emergency Line Interrupt (ELI), Emergency Agency Call, and Operator-assisted Directory Assistance.
- 10.1.1 Upon request for BellSouth OCP, BellSouth shall:
- 10.1.2 Process 0+ and 0- dialed local calls.
- 10.1.3 Process 0+ and 0- intraLATA toll calls.
- 10.1.4 Process calls that are billed to Clearwave Communications end user's calling card that can be validated by BellSouth.
- 10.1.5 Process person-to-person calls.
- 10.1.6 Process collect calls.
- 10.1.7 Provide the capability for callers to bill to a third party and shall also process such calls.

- 10.1.8 Process station-to-station calls.
- 10.1.9 Process Busy Line Verify and Emergency Line Interrupt requests.
- 10.1.10 Process emergency call trace originated by Public Safety Answering Points.
- 10.1.11 Process operator-assisted directory assistance calls.
- 10.1.12 Adhere to equal access requirements, providing Clearwave Communications local end users the same IXC access as provided to BellSouth end users.
- 10.1.13 Exercise at least the same level of fraud control in providing Operator Service to Clearwave Communications that BellSouth provides for its own operator service.
- 10.1.14 Perform Billed Number Screening when handling Collect, Person-to-Person, and Billed-to-Third-Party calls.
- 10.1.15 Direct customer account and other similar inquiries to the customer service center designated by Clearwave Communications.
- 10.1.16 Provide call records to Clearwave Communications in accordance with ODUF standards specified in Attachment 7.
- 10.1.17 The interface requirements shall conform to the interface specifications for the platform used to provide Operator Services as long as the interface conforms to industry standards.
- 10.2 **Directory Assistance Service**
- 10.2.1 Directory Assistance (DA) Service provides local and non-local end user telephone number listings with the option to complete the call at the caller's direction separate and distinct from local switching.
- 10.2.2 DA Service shall provide up to two listing requests per call. If available and if requested by Clearwave Communications's end user, BellSouth shall provide caller-optional directory assistance call completion service at rates contained in this Attachment to one of the provided listings.
- 10.3 DA Service Updates
- 10.3.1 BellSouth shall update end user listings changes daily. These changes include:
- 10.3.2 New end user connections;
- 10.3.3 End user disconnections;
- 10.3.4 End user address changes.



10.3.5 These updates shall also be provided for non-listed and non-published numbers for use in emergencies.

10.4 **Branding for Operator Call Processing and Directory Assistance**

10.4.1 BellSouth's branding feature provides a definable announcement to Clearwave Communications end users using DA/OCP prior to placing such end users in queue or connecting them to an available operator or automated operator system. This feature allows Clearwave Communications to have its calls custom branded with Clearwave Communications's name on whose behalf BellSouth is providing DA and/or OCP. Rates for the branding features are set forth in this Attachment.

10.4.2 BellSouth offers three branding offering options to Clearwave Communications when ordering BellSouth's DA and OCP: BellSouth Branding, Unbranding and Custom Branding.

10.4.3 Upon receipt of the custom branding order from Clearwave Communications, the order is considered firm after ten business days. Should Clearwave Communications decide to cancel the order, written notification to Clearwave Communications's Local Contract Manager is required. If Clearwave Communications decides to cancel after ten business days from receipt of the custom branding order, Clearwave Communications shall pay all charges per the order.

10.4.4 **UNE Provider Branding via Originating Line Number Screening (OLNS)**

10.4.4.1 BellSouth Branding, Unbranding and Custom Branding are also available for DA, OCP or both via Originating Line Number Screening (OLNS) software. When utilizing this method of Unbranding or Custom Branding, Clearwave Communications shall not be required to purchase dedicated trunking.

10.4.4.2 BellSouth Branding is the default branding offering.

10.4.4.3 For BellSouth to provide Unbranding or Custom Branding via OLNS software for OCP or for DA, Clearwave Communications must have its Operating Company Number (OCN(s)) and telephone numbers reside in BellSouth's LIDB; however, a BellSouth LIDB Storage Agreement is not required. To implement Unbranding and Custom Branding via OLNS software, Clearwave Communications must submit a manual order form which requires, among other things, Clearwave Communications's OCN and a forecast for the traffic volume anticipated for each BellSouth TOPS during the peak busy hour. Clearwave Communications shall provide updates to such forecast on a quarterly basis and at any time such forecasted traffic volumes are expected to change significantly. Upon Clearwave Communications's purchase of Unbranding or Custom Branding using OLNS software for any particular TOPS, all Clearwave Communications end users served

by that TOPS will receive the Unbranded “no announcement” or the Custom Branded announcement.

10.4.4.4 Rates for Unbranding and Custom Branding via OLNS software for DA and for OCP are as set forth in this Attachment. In addition to the charges for Unbranding and Custom Branding via OLNS software, Clearwave Communications shall continue to pay BellSouth applicable labor and other charges for the use of BellSouth’s DA and OCP platforms as set forth in this Attachment. Further, where Clearwave Communications is purchasing unbundled local switching from BellSouth, UNE usage charges for end office switching, tandem switching and transport, as applicable, shall continue to apply.

10.4.5 **Facilities Based Carrier Branding**

10.4.5.1 All Service Levels require Clearwave Communications to order dedicated trunking from their end office(s) point of interface to the BellSouth TOPS Switches. Rates for trunks are set forth in applicable BellSouth tariffs.

10.4.5.2 Unbranding is the default branding offering.

10.4.5.3 Rates for Custom Branded OCP/DA are set forth in this Attachment.

10.4.6 **Selective Call Routing Using Line Class Codes (SCR-LCC)**

10.4.6.1 Where Clearwave Communications purchases unbundled local switching from BellSouth and utilizes an Operator Services Provider other than BellSouth, BellSouth will route Clearwave Communications’s end user calls to that provider through Selective Call Routing.

10.4.6.2 Selective Call Routing using Line Class Codes (SCR-LCC) provides the capability for Clearwave Communications to have its OCP/DA calls routed to BellSouth’s OCP/DA platform for BellSouth provided Custom Branded or Unbranded OCP/DA or to its own or an alternate OCP/DA platform for Self-Branded OCP/DA. SCR-LCC is only available if line class code capacity is available in the requested BellSouth end office switches.

10.4.6.3 Custom Branding for DA is not available for certain classes of service, including but not limited to Hotel/Motel services, WATS service, and certain PBX services.

10.4.6.4 Where available, Clearwave Communications specific and unique line class codes are programmed in each BellSouth end office switch where Clearwave Communications intends to serve end users with customized OCP/DA branding. The line class codes specifically identify Clearwave Communications’s end users so OCP/DA calls can be routed over the appropriate trunk group to the requested OCP/DA platform. Additional line class codes are required in each end office if the end office serves multiple NPAs (i.e., a unique LCC is required per NPA), and/or if the end office switch serves multiple rate areas and Clearwave

Communications intends to provide Clearwave Communications -branded OCP/DA to its end users in these multiple rate areas.

- 10.4.6.5 BellSouth Branding is the default branding offering.
- 10.4.6.6 SCR-LCC supporting Custom Branding and Self Branding require Clearwave Communications to order dedicated trunking from each BellSouth end office identified by Clearwave Communications, either to the BellSouth Traffic Operator Position System (TOPS) for Custom Branding or to the Clearwave Communications Operator Service Provider for Self Branding. Separate trunk groups are required for Operator Services and for Directory Assistance. Rates for trunks are set forth in applicable BellSouth tariffs.
- 10.4.6.7 Unbranding - Unbranded DA and/or OCP calls ride common trunk groups provisioned by BellSouth from those end offices identified by Clearwave Communications to the BellSouth TOPS. These calls are routed to "No Announcement."
- 10.4.6.8 The Rates for SCR-LCC are as set forth in this Attachment. There is a nonrecurring charge for the establishment of each Line Class Code in each BellSouth central office. Furthermore, for Unbranded and Custom Branded OCP/DA provided by BellSouth Operator Services with unbundled ports and unbundled port/Loop switch combinations, monthly recurring usage charges shall apply for the UNEs necessary to provide the service, such as end office and tandem switching and common transport. A flat rated end office switching charge shall apply to Self-Branded OCP/DA when used in conjunction with unbundled ports and unbundled port/Loop switch combinations.
- 10.4.7 Customized Branding includes charges for the recording of the branding announcement and the loading of the audio units in each TOPS Switch and Network Applications Vehicle (NAV) equipment for which Clearwave Communications requires service.
  - 10.4.7.1 Directory Assistance customized branding uses:
    - 10.4.7.2 the recording of Clearwave Communications;
    - 10.4.7.3 the loading of the recording in each switch.
  - 10.4.7.4 Operator Call Processing customized branding uses:
    - 10.4.7.5 the recording of Clearwave Communications;
    - 10.4.7.6 the loading of the recording in each switch (North Carolina);
    - 10.4.7.7 the loading on the Network Applications Vehicle (NAV). All NAV shelves within the region where the customer is offering service must be loaded.

## 10.5 **Directory Assistance Database Service (DADS)**

10.5.1 BellSouth shall make its Directory Assistance Database Service (DADS) available at the rates set forth in this Attachment solely for the expressed purpose of providing Directory Assistance type services to Clearwave Communications end users. The term “end user” denotes any entity that obtains Directory Assistance type services for its own use from a DADS customer. Directory Assistance type service is defined as Voice Directory Assistance (DA Operator assisted) and Electronic Directory Assistance (Data System assisted). Clearwave Communications agrees that DADS will not be used for any purpose that violates federal or state laws, statutes, regulatory orders or tariffs. For the purposes of provisioning a Directory Assistance type service, all terms and conditions of GSST A38 apply and are incorporated by reference herein. Except for the permitted uses, Clearwave Communications agrees not to disclose DADS to others and shall provide due care in providing for the security and confidentiality of DADS.

10.5.2 BellSouth shall initially provide Clearwave Communications with a Base File of subscriber listings via magnetic tape. DADS is available and may be ordered on a Business, Residence or combined Business and Residence listings basis for each central office requested. BellSouth will require approximately 30-45 days after receiving an order from Clearwave Communications to prepare the Base File.

10.5.3 BellSouth will provide updates on either a daily or weekly basis reflecting all listing change activity occurring since Clearwave Communications’s previous update. Delivery of updates will commence immediately after Clearwave Communications receives the Base File. Updates will be provided via magnetic tape unless BellSouth and Clearwave Communications mutually develop CONNECT: Direct™ electronic connectivity. Clearwave Communications will pay all costs associated with CONNECT: Direct™ connectivity, which will vary depending upon volume and mileage.

10.5.4 Clearwave Communications authorizes the inclusion of Clearwave Communications Directory Assistance listings in the BellSouth Directory Assistance products including but not limited to DADS. Any other use is not authorized.

## 10.6 **Direct Access to Directory Assistance Service**

10.6.1 Direct Access to Directory Assistance Service (DADAS) will provide Clearwave Communications’s directory assistance operators with the ability to search, using a standard directory assistance search format, the same listing information that is available to BellSouth operators including all available BellSouth subscriber listings, all available listings associated with lines resold by competitive local exchange carriers, and all available listings associated with lines provisioned by local exchange carriers that provide their listings to BellSouth. DADAS will also provide Clearwave Communications with the ability to search all listings BellSouth

obtains from sources other than the provider of the local exchange lines associated with the listings. The search format will be provided to Clearwave Communications by BellSouth upon subscription to the service. Subscription to DADAS requires that Clearwave Communications utilize its own switch, operator workstations, directory assistance operators, transport facilities, and optional audio subsystems.

10.6.2 Rates, terms and conditions for provisioning DADAS are as set forth in the FCC Tariff No. 1.

## **11 Automatic Location Identification/Data Management System (ALI/DMS)**

11.1 The ALI/DMS Database contains end user information (including name, address, telephone information, and sometimes special information from the local service provider or end user) used to determine to which Public Safety Answering Point (PSAP) to route the call. The ALI/DMS database is used to provide enhanced routing flexibility for E911.

11.2 Technical Requirements

11.2.1 BellSouth shall provide Clearwave Communications the capability of providing updates to the ALI/DMS database. BellSouth shall provide error reports from the ALI/DMS database to Clearwave Communications after Clearwave Communications provides end user information for input into the ALI/DMS database.

11.2.2 Clearwave Communications shall conform to the National Emergency Number Association (NENA) recommended standards for Local Number Portability and updating the ALI/DMS database.

## **12 Calling Name (CNAM) Database Service**

12.1 CNAM is the ability to associate a name with the calling party number, allowing the end user (to which a call is being terminated) to view the calling party's name before the call is answered. This service also provides Clearwave Communications the opportunity to load and store its subscriber names in the BellSouth CNAM SCPs.

12.2 Clearwave Communications shall submit to BellSouth a notice of its intent to access and utilize BellSouth CNAM Database Services. Said notice shall be in writing no less than 60 days prior to Clearwave Communications's access to BellSouth's CNAM Database Services and shall be addressed to Clearwave Communications's Local Contract Manager.

12.3 BellSouth's provision of CNAM Database Services to Clearwave Communications requires interconnection from Clearwave Communications to BellSouth CNAM

Service Control Points (SCPs). Such interconnections shall be established pursuant to Attachment 3 of this Agreement, incorporated herein by this reference.

- 12.4 In order to formulate a CNAM query to be sent to the BellSouth CNAM SCP, Clearwave Communications shall provide its own CNAM SSP. Clearwave Communications's CNAM SSPs must be compliant with TR-NWT-001188, "CLASS Calling Name Delivery Generic Requirements".
- 12.5 If Clearwave Communications elects to access the BellSouth CNAM SCP via a third party CCS7 transport provider, the third party CCS7 provider shall interconnect with the BellSouth CCS7 network according to BellSouth's Common Channel Signaling Interconnection Guidelines and Telcordia's CCS Network Interface Specification document, TR-TSV-000905. In addition, the third party provider shall establish CCS7 interconnection at the BellSouth Local Signal Transfer Points (LSTPs) serving the BellSouth CNAM SCPs that Clearwave Communications desires to query.
- 12.6 If Clearwave Communications queries the BellSouth CNAM SCP via a third party national SS7 transport provider, the third party SS7 provider shall interconnect with the BellSouth CCS7 network according to BellSouth's Common Channel Signaling Interconnection Guidelines and Telcordia's CCS Network Interface Specification document, TR-TSV-000905. In addition, the third party provider shall establish SS7 interconnection at one or more of the BellSouth Gateway Signal Transfer Points (STPs). The payment of all costs associated with the transport of SS7 signals via a third party will be established by mutual agreement of the Parties and this Agreement shall be amended in accordance with modification of the General Terms and Conditions incorporated herein by this reference.
- 12.7 The mechanism to be used by Clearwave Communications for initial CNAM record load and/or updates shall be determined by mutual agreement. The initial load and all updates shall be provided by Clearwave Communications in the BellSouth specified format and shall contain records for every working telephone number that can originate phone calls. It is the responsibility of Clearwave Communications to provide accurate information to BellSouth on a current basis.
- 12.8 Updates to the SMS shall occur no less than once a week, reflect service order activity affecting either name or telephone number, and involve only record additions, deletions or changes.
- 12.9 Clearwave Communications CNAM records provided for storage in the BellSouth CNAM SCP shall be available, on a SCP query basis only, to all Parties querying the BellSouth CNAM SCP. Further, CNAM service shall be provided by each Party consistent with state and/or federal regulation.

**13 Service Creation Environment and Service Management System (SCE/SMS) Advanced Intelligent Network (AIN) Access**

- 13.1 BellSouth's Service Creation Environment and Service Management System (SCE/SMS) Advanced Intelligent Network (AIN) Access shall provide Clearwave Communications the capability to create service applications in a BellSouth SCE and deploy those applications in a BellSouth SMS to a BellSouth SCP.
- 13.2 BellSouth's SCE/SMS AIN Access shall provide access to SCE hardware, software, testing and technical support (e.g., help desk, system administrator) resources available to Clearwave Communications. Training, documentation, and technical support will address use of SCE and SMS access and administrative functions but will not include support for the creation of a specific service application.
- 13.3 BellSouth SCP shall partition and protect Clearwave Communications service logic and data from unauthorized access.
- 13.4 When Clearwave Communications selects SCE/SMS AIN Access, BellSouth shall provide training, documentation, and technical support to enable Clearwave Communications to use BellSouth's SCE/SMS AIN Access to create and administer applications.
- 13.5 Clearwave Communications access will be provided via remote data connection (e.g., dial-in, ISDN).
- 13.6 BellSouth shall allow Clearwave Communications to download data forms and/or tables to BellSouth SCP via BellSouth SMS without intervention from BellSouth.

**14 Basic 911 and E911**

- 14.1 Basic 911 and E911 provides a caller access to the applicable emergency service bureau by dialing 911.
- 14.2 Basic 911 Service Provisioning. BellSouth will provide to Clearwave Communications a list consisting of each municipality that subscribes to Basic 911 service. The list will also provide, if known, the E911 conversion date for each municipality and, for network routing purposes, a ten-digit directory number representing the appropriate emergency answering position for each municipality subscribing to 911. Clearwave Communications will be required to arrange to accept 911 calls from its end users in municipalities that subscribe to Basic 911 service and translate the 911 call to the appropriate 10-digit directory number as stated on the list provided by BellSouth. Clearwave Communications will be required to route that call to BellSouth at the appropriate tandem or end office. When a municipality converts to E911 service, Clearwave Communications will be required to begin using E911 procedures.

- 14.3 E911 Service Provisioning. Clearwave Communications shall install a minimum of two dedicated trunks originating from the Clearwave Communications serving wire center and terminating to the appropriate E911 tandem. The dedicated trunks shall be, at a minimum, DS0 level trunks configured either as a 2-wire analog interface or as part of a digital (1.544 Mb/s) interface. Either configuration shall use CAMA-type signaling with multifrequency (MF) pulsing that will deliver automatic number identification (ANI) with the voice portion of the call. If the user interface is digital, MF pulses as well as other AC signals shall be encoded per the u-255 Law convention. Clearwave Communications will be required to provide BellSouth daily updates to the E911 database. Clearwave Communications will be required to forward 911 calls to the appropriate E911 tandem along with ANI based upon the current E911 end office to tandem homing arrangement as provided by BellSouth. If the E911 tandem trunks are not available, Clearwave Communications will be required to route the call to a designated 7-digit local number residing in the appropriate Public Service Answering Point (PSAP). This call will be transported over BellSouth's interoffice network and will not carry the ANI of the calling party. Clearwave Communications shall be responsible for providing BellSouth with complete and accurate data for submission to the 911/E911 database for the purpose of providing 911/E911 to its end users.
- 14.4 Rates. Charges for 911/E911 service are borne by the municipality purchasing the service. BellSouth will impose no charge on Clearwave Communications beyond applicable charges for BellSouth trunking arrangements.
- 14.5 Basic 911 and E911 functions provided to Clearwave Communications shall be at least at parity with the support and services that BellSouth provides to its end users for such similar functionality.
- 14.6 The detailed practices and procedures for 911/E911 services are contained in the E911 Local Exchange Carrier Guide For Facility-Based Providers as amended from time to time during the term of this Agreement.

## 15 **Operational Support Systems (OSS)**

- 15.1 BellSouth has developed and made available the following electronic interfaces by which Clearwave Communications may submit LSRs electronically.
- |      |                                   |
|------|-----------------------------------|
| LENS | Local Exchange Navigation System  |
| EDI  | Electronic Data Interchange       |
| TAG  | Telecommunications Access Gateway |
- 15.2 LSRs submitted by means of one of these electronic interfaces will incur an OSS electronic ordering charge. An individual LSR will be identified for billing purposes by its Purchase Order Number (PON). LSRs submitted by means other than one of these interactive interfaces (mail, fax, courier, etc.) will incur a manual



order charge. All OSS charges are specified in Rate Exhibit B of this Attachment 2.

15.3 Denial/Restoral OSS Charge

15.3.1 In the event Clearwave Communications provides a list of customers to be denied and restored, rather than an LSR, each location on the list will require a separate PON and therefore will be billed as one LSR per location.

15.4 Cancellation OSS Charge

15.4.1 Clearwave Communications will incur an OSS charge for an accepted LSR that is later canceled.

15.5 Supplements or clarifications to a previously billed LSR will not incur another OSS charge.

15.6 Network Elements and Other Services Manual Additive

15.6.1 The Commissions in some states have ordered per-element manual additive nonrecurring charges (NRC) for Network Elements and Other Services ordered by means other than one of the interactive interfaces. These ordered Network Elements and Other Services manual additive NRCs will apply in these states, rather than the charge per LSR. The per-element charges are listed on the Rate Tables in Exhibit B.

**EXHIBIT A****LINE INFORMATION DATA BASE (LIDB)****FACILITIES BASED STORAGE AGREEMENT****I. Definitions**

- A. Billing number - a number that Clearwave Communications creates for the purpose of identifying an account liable for charges. This number may be a line or a special billing number.
- B. Line number - a ten-digit number that identifies a telephone line administered by Clearwave Communications.
- C. Special billing number - a ten-digit number that identifies a billing account established by Clearwave Communications.
- D. Calling Card number - a billing number plus PIN number.
- E. PIN number - a four-digit security code assigned by Clearwave Communications that is added to a billing number to compose a fourteen-digit calling card number.
- F. Toll billing exception indicator - associated with a billing number to indicate that it is considered invalid for billing of collect calls or third number calls or both, by Clearwave Communications.
- G. Billed Number Screening - refers to the query service used to determine whether a toll billing exception indicator is present for a particular billing number.
- H. Calling Card Validation - refers to the query service used to determine whether a particular calling card number exists as stated or otherwise provided by a caller.
- I. Billing number information - information about billing number, Calling Card number and toll billing exception indicator provided to BellSouth by Clearwave Communications.
- J. Account Owner – name of the local exchange telecommunications company that is providing dialtone on a subscriber line.
- K. GetData – refers to the query service used to determine, at a minimum, the Account Owner and/or Regional Accounting Office for a line number. This query service may be modified to provide additional information in the future.
- L. Originating Line Number Screening (OLNS) – refers to the query service used to determine the billing, screening and call handling indicators, station type, and Account

Owner provided to BellSouth by Clearwave Communications for originating line numbers.

## **II. General**

- A. This Agreement sets forth the terms and conditions pursuant to which BellSouth agrees to store in its LIDB certain information at the request of Clearwave Communications and pursuant to which BellSouth, its LIDB customers and Clearwave Communications shall have access to such information. In addition, this Agreement sets forth the terms and conditions for Clearwave Communications's provision of billing number information to BellSouth for inclusion in BellSouth's LIDB. Clearwave Communications understands that BellSouth provides access to information in its LIDB to various telecommunications service providers pursuant to applicable tariffs and agrees that information stored at the request of Clearwave Communications, pursuant to this Agreement, shall be available to those telecommunications service providers. The terms and conditions contained herein shall hereby be made a part of this Interconnection Agreement upon notice to Clearwave Communications's account team and/or Local Contract Manager to activate this LIDB Storage Agreement. The General Terms and Conditions of the Interconnection/Resale Agreement shall govern this LIDB Storage Agreement.
- B. BellSouth will provide responses to on-line, call-by-call queries to local exchange line and/or billing number information for the following purposes:
1. Billed Number Screening

BellSouth is authorized to use the billing number information to determine whether Clearwave Communications has identified the billing number as one that should not be billed for collect or third number calls.
  2. Calling Card Validation

BellSouth is authorized to validate a 14-digit Calling Card number where the first 10 digits are a line number or special billing number assigned by BellSouth and where the last four digits (PIN) are a security code assigned by BellSouth.
  3. OLNS

BellSouth is authorized to provide originating line screening information for billing and services restrictions, station type, and Account Owner on the lines of Clearwave Communications from which a call originates.
  4. GetData

BellSouth is authorized to provide, at a minimum, the Account Owner and/or Regional Accounting Office information on the lines of Clearwave

Communications indicating the local service provider and where billing records are to be sent for settlement purposes. This query service may be modified to provide additional information in the future.

5. Fraud Control

BellSouth will provide seven days per week, 24-hours per day, fraud monitoring on Calling Cards, bill-to-third and collect calls made to numbers in BellSouth's LIDB, provided that such information is included in the LIDB query. BellSouth will establish fraud alert thresholds and will notify Clearwave Communications of fraud alerts so that Clearwave Communications may take action it deems appropriate.

**III. Responsibilities of the Parties**

A. BellSouth will administer all data stored in the LIDB, including the data provided by Clearwave Communications pursuant to this Agreement, in the same manner as BellSouth's data for BellSouth's end user customers. BellSouth shall not be responsible to Clearwave Communications for any lost revenue which may result from BellSouth's administration of the LIDB pursuant to its established practices and procedures as they exist and as they may be changed by BellSouth in its sole discretion from time to time.

B. Billing and Collection Customers

BellSouth currently has in effect numerous billing and collection agreements with various interexchange carriers and billing clearinghouses and as such these billing and collection customers (B&C Customers) query BellSouth's LIDB to determine whether to accept various billing options from end users. Until such time as BellSouth implements in its LIDB and its supporting systems the means to differentiate Clearwave Communications's data from BellSouth's data, the following terms and conditions shall apply:

1. BellSouth will identify Clearwave Communications's end user originated long distance charges and will return those charges to the interexchange carrier as not covered by the existing B&C agreement with interexchange carriers for handling of long distance charges by their end users.
2. BellSouth shall have no obligation to become involved in any disputes between Clearwave Communications and B&C Customers. BellSouth will not issue adjustments for charges billed on behalf of any B&C Customer to Clearwave Communications. It shall be the responsibility of Clearwave Communications and the B&C Customers to negotiate and arrange for any appropriate adjustments.

**IV. Fees for Service and Taxes**

- A. Clearwave Communications will not be charged a fee for storage services provided by BellSouth to Clearwave Communications as described in this LIDB Facilities Based Storage Agreement.
- B. Sales, use and all other taxes (excluding taxes on BellSouth's income) determined by BellSouth or any taxing authority to be due to any federal, state or local taxing jurisdiction with respect to the provision of the service set forth herein will be paid by Clearwave Communications in accordance with the tax provisions set forth in the General Terms and Conditions of this Agreement.

UNBUNDLED NETWORK ELEMENTS - Kentucky										Attachment: 2		Exhibit: B				
CATEGORY	RATE ELEMENTS	Interim	Zone	BCS	USOC	RATES (\$)	Svc Order Submitted Elec per LSR	Svc Order Submitted Manually per LSR	Incremental Charge - Manual Svc Order vs. Electronic-1st	Incremental Charge - Manual Svc Order vs. Electronic-Add'l	Incremental Charge - Manual Svc Order vs. Electronic-Disc 1st	Incremental Charge - Manual Svc Order vs. Electronic-Disc Add'l				
							Rec	Nonrecurring		Nonrecurring Disconnect		OSS Rates(\$)				
							First	Add'l	First	Add'l	SOMEC	SOMAN	SOMAN	SOMAN	SOMAN	SOMAN
The "Zone" shown in the sections for stand-alone loops or loops as part of a combination refers to Geographically Deaveraged UNE Zones. To view Geographically Deaveraged UNE Zone Designations by Central Office, refer to internet Website: <a href="http://www.interconnection.bellsouth.com/become_a_clec/html/interconnection.htm">http://www.interconnection.bellsouth.com/become_a_clec/html/interconnection.htm</a>																
<b>OPERATIONAL SUPPORT SYSTEMS</b>																
NOTE: (1) Electronic Service Order: CLEC should contact its contract negotiator if it prefers the state specific electronic service ordering charges as ordered by the State Commissions. The electronic service ordering charge currently contained in this rate exhibit is the BellSouth regional electronic service ordering charge. CLEC may elect either the state specific Commission ordered rates for the electronic service ordering charges, or CLEC may elect the regional electronic service ordering charge.																
NOTE: (2) Any element that can be ordered electronically will be billed according to the SOMEC rate listed in this category. Please refer to BellSouth's Business Rules for Local Ordering (BBR-LO) to determine if a product can be ordered electronically. For those elements that cannot be ordered electronically at present per the BBR-LO, the listed SOMEC rate in this category reflects the charge that would be billed to a CLEC once electronic ordering capabilities come on-line for that element. Otherwise, the manual ordering charge, SOMAN, will be applied to a CLECs bill when it submits an LSR to BellSouth.																
	Manual Service Order Charge, per LSR, Disconnect Only (KY)				SOMAN				0.99							
	Electronic OSS Charge, per LSR, submitted via BST's OSS interactive interfaces (Regional)				SOMEC		3.50									
<b>UNE SERVICE DATE ADVANCEMENT CHARGE</b>																
NOTE: The Expedite charge will be maintained commensurate with BellSouth's FCC No.1 Tariff, Section 5 as applicable.																
	UNE Expedite Charge per Circuit or Line Assignable USOC, per Day			UAL, UEANL, UCL, UEF, UDF, UEQ, UDL, UENTW, UDN, UEA, UHL, ULC, USL, U1T12, U1T48, U1TD1, U1TD3, U1TDX, U1TO3, U1TS1, U1TVX, UC1BC, UC1BL, UC1CC, UC1CL, UC1DC, UC1DL, UC1EC, UC1EL, UC1FC, UC1FL, UC1GC, UC1GL, UC1HC, UC1HL, UDL12, UDL48, UDLO3, UDLSX, UE3, ULD12, ULD48, ULDD1, ULDD3, ULDDX, ULDO3, ULDS1, ULDVX, UNC1X, UNC3X, UNCDX, UNCNX, UNCSX, UNCVX, UNLD1, UNLD3, UXTD1, UXTD3, UXTS1, U1TUC, U1TUD, U1TUB, U1TUA	SDASP		200.00									
<b>UNBUNDLED EXCHANGE ACCESS LOOP</b>																
<b>2-WIRE ANALOG VOICE GRADE LOOP</b>																
	2-Wire Analog Voice Grade Loop - Service Level 1- Zone 1		1	UEANL	UEAL2	10.56	46.66	22.57	26.65	7.65		7.86				
	2-Wire Analog Voice Grade Loop - Service Level 1- Zone 2		2	UEANL	UEAL2	15.34	46.66	22.57	26.65	7.65		7.86				
	2-Wire Analog Voice Grade Loop - Service Level 1- Zone 3		3	UEANL	UEAL2	31.11	46.66	22.57	26.65	7.65		7.86				
	Unbundled Miscellaneous Rate Element, Tag Loop at End User Premise			UEANL	URETL		8.33	0.83				7.86				
	Loop Testing - Basic 1st Half Hour			UEANL	URET1		46.88	46.88				7.86				
	Loop Testing - Basic Additional Half Hour			UEANL	URETA		24.16	24.16				7.86				
	CLEC to CLEC Conversion Charge Without Outside Dispatch (UVL-SL1)			UEANL	UREWO		15.78	8.94				7.86				
	Unbundled Voice Loop, Non-Design Voice Loop, billing for BST providing make-up (Engineering Information - E.I.)			UEANL	UEANM		13.49	13.49								
	Manual Order Coordination for UVL-SL1s (per loop)			UEANL	UEAMC		9.00	9.00								

UNBUNDLED NETWORK ELEMENTS - Kentucky							Attachment: 2		Exhibit: B							
CATEGORY	RATE ELEMENTS	Interim	Zone	BCS	USOC	RATES (\$)	Svc Order Submitted Elec per LSR	Svc Order Submitted Manually per LSR	Incremental Charge - Manual Svc Order vs. Electronic-1st	Incremental Charge - Manual Svc Order vs. Electronic-Add'l	Incremental Charge - Manual Svc Order vs. Electronic-Disc 1st	Incremental Charge - Manual Svc Order vs. Electronic-Disc Add'l				
						Rec	Nonrecurring		Nonrecurring Disconnect		OSS Rates(\$)					
							First	Add'l	First	Add'l	SOMEC	SOMAN	SOMAN	SOMAN	SOMAN	SOMAN
	Order Coordination for Specified Conversion Time for UVL-SL1 (per LSR)			UEANL	OCOSL		23.01	23.01								
	<b>2-WIRE Unbundled COPPER LOOP</b>															
	2-Wire Unbundled Copper Loop - Non-Designed Zone 1	I	1	UEQ	UEQ2X	10.58	44.97	20.89	25.64	6.65		7.86				
	2 Wire Unbundled Copper Loop - Non-Designed - Zone 2	I	2	UEQ	UEQ2X	11.51	44.97	20.89	25.64	6.65		7.86				
	2 Wire Unbundled Copper Loop - Non-Designed - Zone 3	I	3	UEQ	UEQ2X	13.19	44.97	20.89	25.64	6.65		7.86				
	Unbundled Miscellaneous Rate Element, Tag Loop at End User Premise			UEQ	URETL		8.33	0.83				7.86				
	Order Coordination 2 Wire Unbundled Copper Loop - Non-Designed (per loop)			UEQ	USBMC		9.00	9.00								
	Unbundled Copper Loop, Non-Design Copper Loop, billing for BST providing make-up (Engineering Information - E.I.)			UEQ	UEQMU		13.49	13.49								
	Loop Testing - Basic 1st Half Hour			UEQ	URET1		46.88	46.88				7.86				
	Loop Testing - Basic Additional Half Hour			UEQ	URETA		24.16	24.16				7.86				
	CLEC to CLEC Conversion Charge Without Outside Dispatch (UCL-ND)			UEQ	UREWO		14.27	7.43				7.86				
	<b>UNBUNDLED EXCHANGE ACCESS LOOP</b>															
	<b>2-WIRE ANALOG VOICE GRADE LOOP</b>															
	2 Wire Analog Voice Grade Loop-Service Level 1-Line Splitting-Zone 1		1	UEPSR UEPSB	UEALS	10.56	46.66	22.57	26.65	7.65		7.86				
	2 Wire Analog Voice Grade Loop-Service Level 1-Line Splitting-Zone 1		1	UEPSR UEPSB	UEABS	10.56	46.66	22.57	26.65	7.65		7.86				
	2 Wire Analog Voice Grade Loop- Service Level 1-Line Splitting-Zone 2		2	UEPSR UEPSB	UEALS	15.34	46.66	22.57	26.65	7.65		7.86				
	2 Wire Analog Voice Grade Loop- Service Level 1-Line Splitting-Zone 2		2	UEPSR UEPSB	UEABS	15.34	46.66	22.57	26.65	7.65		7.86				
	2 Wire Analog Voice Grade Loop-Service Level 1-Line Splitting-Zone 3		3	UEPSR UEPSB	UEALS	31.11	46.66	22.57	26.65	7.65		7.86				
	2 Wire Analog Voice Grade Loop-Service Level 1-Line Splitting-Zone 3		3	UEPSR UEPSB	UEABS	31.11	46.66	22.57	26.65	7.65		7.86				
	<b>UNBUNDLED EXCHANGE ACCESS LOOP</b>															
	<b>2-WIRE ANALOG VOICE GRADE LOOP</b>															
	2-Wire Analog Voice Grade Loop - Service Level 2 w/Loop or Ground Start Signaling - Zone 1		1	UEA	UEAL2	12.67	134.89	81.87	73.65	14.88		7.86				
	2-Wire Analog Voice Grade Loop - Service Level 2 w/Loop or Ground Start Signaling - Zone 2		2	UEA	UEAL2	17.45	134.89	81.87	73.65	14.88		7.86				
	2-Wire Analog Voice Grade Loop - Service Level 2 w/Loop or Ground Start Signaling - Zone 3		3	UEA	UEAL2	33.22	134.89	81.87	73.65	14.88		7.86				
	Order Coordination for Specified Conversion Time (per LSR)			UEA	OCOSL		23.01									
	2-Wire Analog Voice Grade Loop - Service Level 2 w/Reverse Battery Signaling - Zone 1		1	UEA	UEAR2	12.67	134.89	81.87	73.65	14.88		7.86				
	2-Wire Analog Voice Grade Loop - Service Level 2 w/Reverse Battery Signaling - Zone 2		2	UEA	UEAR2	17.45	134.89	81.87	73.65	14.88		7.86				
	2-Wire Analog Voice Grade Loop - Service Level 2 w/Reverse Battery Signaling - Zone 3		3	UEA	UEAR2	33.22	134.89	81.87	73.65	14.88		7.86				
	Order Coordination for Specified Conversion Time (per LSR)			UEA	OCOSL		23.01									
	CLEC to CLEC Conversion Charge without outside dispatch			UEA	UREWO		87.72	36.36				7.86				
	Loop Tagging - Service Level 2 (SL2)			UEA	URETL		11.21	1.10				7.86				
	<b>4-WIRE ANALOG VOICE GRADE LOOP</b>															
	4-Wire Analog Voice Grade Loop - Zone 1		1	UEA	UEAL4	29.26	164.11	112.36	78.91	18.66		7.86				
	4-Wire Analog Voice Grade Loop - Zone 2		2	UEA	UEAL4	34.25	164.11	112.36	78.91	18.66		7.86				
	4-Wire Analog Voice Grade Loop - Zone 3		3	UEA	UEAL4	85.06	164.11	112.36	78.91	18.66		7.86				
	Order Coordination for Specified Conversion Time (per LSR)			UEA	OCOSL		23.01									
	CLEC to CLEC Conversion Charge without outside dispatch			UEA	UREWO		87.72	36.36				7.86				
	<b>2-WIRE ISDN DIGITAL GRADE LOOP</b>															
	2-Wire ISDN Digital Grade Loop - Zone 1		1	UDN	U1L2X	18.44	146.77	95.02	71.38	13.83		7.86				
	2-Wire ISDN Digital Grade Loop - Zone 2		2	UDN	U1L2X	25.08	146.77	95.02	71.38	13.83		7.86				
	2-Wire ISDN Digital Grade Loop - Zone 3		3	UDN	U1L2X	42.87	146.77	95.02	71.38	13.83		7.86				
	Order Coordination For Specified Conversion Time (per LSR)			UDN	OCOSL		23.01									

UNBUNDLED NETWORK ELEMENTS - Kentucky										Attachment: 2		Exhibit: B								
CATEGORY	RATE ELEMENTS	Interim	Zone	BCS	USOC	RATES (\$)	Svc Order Submitted Elec per LSR	Svc Order Submitted Manually per LSR	Incremental Charge - Manual Svc Order vs. Electronic-1st	Incremental Charge - Manual Svc Order vs. Electronic-Add'l	Incremental Charge - Manual Svc Order vs. Electronic-Disc 1st	Incremental Charge - Manual Svc Order vs. Electronic-Disc Add'l	OSS Rates(\$)							
													Rec	Nonrecurring First	Nonrecurring Add'l	Nonrecurring Disconnect First	Nonrecurring Disconnect Add'l	SOMEK	SOMAN	SOMAN
	CLEC to CLEC Conversion Charge without outside dispatch			UDN	UREWO		91.63	44.16					7.86							
	<b>2-WIRE Universal Digital Channel (UDC) COMPATIBLE LOOP</b>																			
	2-Wire Universal Digital Channel (UDC) Compatible Loop - Zone 1		1	UDC	UDC2X	18.44	146.77	95.02	71.38	13.83			7.86							
	2-Wire Universal Digital Channel (UDC) Compatible Loop - Zone 2		2	UDC	UDC2X	25.08	146.77	95.02	71.38	13.83			7.86							
	2-Wire Universal Digital Channel (UDC) Compatible Loop - Zone 3		3	UDC	UDC2X	42.87	146.77	95.02	71.38	13.83			7.86							
	CLEC to CLEC Conversion Charge without outside dispatch			UDC	UREWO		91.63	44.16					7.86							
	<b>2-WIRE ASYMMETRICAL DIGITAL SUBSCRIBER LINE (ADSL) COMPATIBLE LOOP</b>																			
	2 Wire Unbundled ADSL Loop including manual service inquiry & facility reservation - Zone 1		1	UAL	UAL2X	10.82	141.98	79.73	69.02	11.47			7.86							
	2 Wire Unbundled ADSL Loop including manual service inquiry & facility reservation - Zone 2		2	UAL	UAL2X	11.79	141.98	79.73	69.02	11.47			7.86							
	2 Wire Unbundled ADSL Loop including manual service inquiry & facility reservation - Zone 3		3	UAL	UAL2X	12.87	141.98	79.73	69.02	11.47			7.86							
	Order Coordination for Specified Conversion Time (per LSR)			UAL	OCOSL		23.01													
	2 Wire Unbundled ADSL Loop without manual service inquiry & facility reservation - Zone 1		1	UAL	UAL2W	10.82	121.18	69.00	69.09	11.54			7.86							
	2 Wire Unbundled ADSL Loop without manual service inquiry & facility reservation - Zone 2		2	UAL	UAL2W	11.79	121.18	69.00	69.09	11.54			7.86							
	2 Wire Unbundled ADSL Loop without manual service inquiry & facility reservation - Zone 3		3	UAL	UAL2W	12.87	121.18	69.00	69.09	11.54			7.86							
	Order Coordination for Specified Conversion Time (per LSR)			UAL	OCOSL		23.01													
	CLEC to CLEC Conversion Charge without outside dispatch			UAL	UREWO		86.20	40.40					7.86							
	<b>2-WIRE HIGH BIT RATE DIGITAL SUBSCRIBER LINE (HDSL) COMPATIBLE LOOP</b>																			
	2 Wire Unbundled HDSL Loop including manual service inquiry & facility reservation - Zone 1		1	UHL	UHL2X	8.75	151.54	89.29	69.09	11.54			7.86							
	2 Wire Unbundled HDSL Loop including manual service inquiry & facility reservation - Zone 2		2	UHL	UHL2X	9.56	151.54	89.29	69.09	11.54			7.86							
	2 Wire Unbundled HDSL Loop including manual service inquiry & facility reservation - Zone 3		3	UHL	UHL2X	10.61	151.54	89.29	69.09	11.54			7.86							
	Order Coordination for Specified Conversion Time (per LSR)			UHL	OCOSL		23.01													
	2 Wire Unbundled HDSL Loop without manual service inquiry and facility reservation - Zone 1		1	UHL	UHL2W	8.75	130.74	78.56	69.09	11.54			7.86							
	2 Wire Unbundled HDSL Loop without manual service inquiry and facility reservation - Zone 2		2	UHL	UHL2W	9.56	130.74	78.56	69.09	11.54			7.86							
	2 Wire Unbundled HDSL Loop without manual service inquiry and facility reservation - Zone 3		3	UHL	UHL2W	10.61	130.74	78.56	69.09	11.54			7.86							
	Order Coordination for Specified Conversion Time (per LSR)			UHL	OCOSL		23.01													
	CLEC to CLEC Conversion Charge without outside dispatch			UHL	UREWO		86.14	40.40					7.86							
	<b>4-WIRE HIGH BIT RATE DIGITAL SUBSCRIBER LINE (HDSL) COMPATIBLE LOOP</b>																			
	4 Wire Unbundled HDSL Loop including manual service inquiry and facility reservation - Zone 1		1	UHL	UHL4X	13.95	185.75	123.50	74.95	14.69			7.86							
	4-Wire Unbundled HDSL Loop including manual service inquiry and facility reservation - Zone 2		2	UHL	UHL4X	15.68	185.75	123.50	74.95	14.69			7.86							
	4-Wire Unbundled HDSL Loop including manual service inquiry and facility reservation - Zone 3		3	UHL	UHL4X	16.98	185.75	123.50	74.95	14.69			7.86							
	Order Coordination for Specified Conversion Time (per LSR)			UHL	OCOSL		23.01													
	4-Wire Unbundled HDSL Loop without manual service inquiry and facility reservation - Zone 1		1	UHL	UHL4W	13.95	164.95	114.04	77.32	15.80			7.86							
	4-Wire Unbundled HDSL Loop without manual service inquiry and facility reservation - Zone 2		2	UHL	UHL4W	15.68	164.95	114.04	77.32	15.80			7.86							
	4-Wire Unbundled HDSL Loop without manual service inquiry and facility reservation - Zone 3		3	UHL	UHL4W	16.98	164.95	114.04	77.32	15.80			7.86							
	Order Coordination for Specified Conversion Time (per LSR)			UHL	OCOSL		23.01													
	CLEC to CLEC Conversion Charge without outside dispatch			UHL	UREWO		86.14	40.40					7.86							
	<b>4-WIRE DS1 DIGITAL LOOP</b>																			
	4-Wire DS1 Digital Loop - Zone 1		1	USL	USLXX	86.47	306.69	174.44	65.83	14.55			7.86							



UNBUNDLED NETWORK ELEMENTS - Kentucky											Attachment: 2		Exhibit: B							
CATEGORY	RATE ELEMENTS	Interim	Zone	BCS	USOC	RATES (\$)	Svc Order Submitted Elec per LSR	Svc Order Submitted Manually per LSR	Incremental Charge - Manual Svc Order vs. Electronic-1st	Incremental Charge - Manual Svc Order vs. Electronic-Add'l	Incremental Charge - Manual Svc Order vs. Electronic-Disc 1st	Incremental Charge - Manual Svc Order vs. Electronic-Disc Add'l	OSS Rates(\$)							
													Rec	Nonrecurring		Nonrecurring Disconnect		SOMEK	SOMAN	SOMAN
													First	Add'l	First	Add'l				
	4-Wire DS1 Digital Loop - Zone 2		2	USL	USLXX	114.10							306.69	174.44	65.83	14.55				
	4-Wire DS1 Digital Loop - Zone 3		3	USL	USLXX	297.76							306.69	174.44	65.83	14.55				
	Order Coordination for Specified Conversion Time (per LSR)			USL	OCOSL								23.01							
	CLEC to CLEC Conversion Charge without outside dispatch			USL	UREWO								101.09	43.04						
	<b>4-WIRE 19.2, 56 OR 64 KBPS DIGITAL GRADE LOOP</b>																			
	4 Wire Unbundled Digital 19.2 Kbps		1	UDL	UDL19	27.59							157.81	106.06	78.91	18.66				7.86
	4 Wire Unbundled Digital 19.2 Kbps		2	UDL	UDL19	32.48							157.81	106.06	78.91	18.66				7.86
	4 Wire Unbundled Digital 19.2 Kbps		3	UDL	UDL19	36.37							157.81	106.06	78.91	18.66				7.86
	4 Wire Unbundled Digital Loop 56 Kbps - Zone 1		1	UDL	UDL56	27.59							157.81	106.06	78.91	18.66				7.86
	4 Wire Unbundled Digital Loop 56 Kbps - Zone 2		2	UDL	UDL56	32.48							157.81	106.06	78.91	18.66				7.86
	4 Wire Unbundled Digital Loop 56 Kbps - Zone 3		3	UDL	UDL56	36.37							157.81	106.06	78.91	18.66				7.86
	Order Coordination for Specified Conversion Time (per LSR)			UDL	OCOSL								23.01							
	4 Wire Unbundled Digital Loop 64 Kbps - Zone 1		1	UDL	UDL64	27.59							157.81	106.06	78.91	18.66				7.86
	4 Wire Unbundled Digital Loop 64 Kbps - Zone 2		2	UDL	UDL64	32.48							157.81	106.06	78.91	18.66				7.86
	4 Wire Unbundled Digital Loop 64 Kbps - Zone 3		3	UDL	UDL64	36.37							157.81	106.06	78.91	18.66				7.86
	Order Coordination for Specified Conversion Time (per LSR)			UDL	OCOSL								23.01							
	CLEC to CLEC Conversion Charge without outside dispatch			UDL	UREWO								102.13	49.75						7.86
	<b>2-WIRE Unbundled COPPER LOOP</b>																			
	2-Wire Unbundled Copper Loop/Short including manual service inquiry & facility reservation - Zone 1		1	UCL	UCLPB	10.82							140.95	78.70	69.09	11.54				7.86
	2-Wire Unbundled Copper Loop/Short including manual service inquiry & facility reservation - Zone 2		2	UCL	UCLPB	11.79							140.95	78.70	69.09	11.54				7.86
	2 Wire Unbundled Copper Loop/Short including manual service inquiry & facility reservation - Zone 3		3	UCL	UCLPB	12.87							140.95	78.70	69.09	11.54				7.86
	Order Coordination for Unbundled Copper Loops (per loop)			UCL	UCLMC								9.00	9.00						
	2-Wire Unbundled Copper Loop/Short without manual service inquiry and facility reservation - Zone 1		1	UCL	UCLPW	10.82							120.15	67.97	69.09	11.54				7.86
	2-Wire Unbundled Copper Loop/Short without manual service inquiry and facility reservation - Zone 2		2	UCL	UCLPW	11.79							120.15	67.97	69.09	11.54				7.86
	2-Wire Unbundled Copper Loop/Short without manual service inquiry and facility reservation - Zone 3		3	UCL	UCLPW	12.87							120.15	67.97	69.09	11.54				7.86
	Order Coordination for Unbundled Copper Loops (per loop)			UCL	UCLMC								9.00	9.00						
	2-Wire Unbundled Copper Loop/Long - includes manual svc. inquiry and facility reservation - Zone 1		1	UCL	UCL2L	24.91							140.95	78.70	69.09	11.54				7.86
	2-Wire Unbundled Copper Loop/Long - includes manual svc. inquiry and facility reservation - Zone 2		2	UCL	UCL2L	36.94							140.95	78.70	69.09	11.54				7.86
	2-Wire Unbundled Copper Loop/Long - includes manual svc. inquiry and facility reservation - Zone 3		3	UCL	UCL2L	69.95							140.95	78.70	69.09	11.54				7.86
	Order Coordination for Unbundled Copper Loops (per loop)			UCL	UCLMC								9.00	9.00						
	2-Wire Unbundled Copper Loop/Long - without manual service inquiry and facility reservation - Zone 1		1	UCL	UCL2W	24.91							120.15	67.97	69.09	11.54				7.86
	2-Wire Unbundled Copper Loop/Long - without manual service inquiry and facility reservation - Zone 2		2	UCL	UCL2W	36.94							120.15	67.97	69.09	11.54				7.86
	2-Wire Unbundled Copper Loop/Long - without manual service inquiry and facility reservation - Zone 3		3	UCL	UCL2W	69.95							120.15	67.97	69.09	11.54				7.86
	Order Coordination for Unbundled Copper Loops (per loop)			UCL	UCLMC								9.00	9.00						
	CLEC to CLEC Conversion Charge without outside dispatch (UCL-Des)			UCL	UREWO								97.23	42.48						7.86
	<b>4-WIRE COPPER LOOP</b>																			
	4-Wire Copper Loop/Short - including manual service inquiry and facility reservation - Zone 1		1	UCL	UCL4S	16.92							170.31	108.06	74.95	14.69				7.86
	4-Wire Copper Loop/Short - including manual service inquiry and facility reservation - Zone 2		2	UCL	UCL4S	17.36							170.31	108.06	74.95	14.69				7.86
	4-Wire Copper Loop/Short - including manual service inquiry and facility reservation - Zone 3		3	UCL	UCL4S	28.10							170.31	108.06	74.95	14.69				7.86
	Order Coordination for Unbundled Copper Loops (per loop)			UCL	UCLMC								9.00	9.00						
	4-Wire Copper Loop/Short - without manual service inquiry and facility reservation - Zone 1		1	UCL	UCL4W	16.92							149.52	97.33	74.95	14.69				7.86

UNBUNDLED NETWORK ELEMENTS - Kentucky										Attachment: 2		Exhibit: B			
CATEGORY	RATE ELEMENTS	Interim	Zone	BCS	USOC	RATES (\$)				Svc Order Submitted Elec per LSR	Svc Order Submitted Manually per LSR	Incremental Charge - Manual Svc Order vs. Electronic-1st	Incremental Charge - Manual Svc Order vs. Electronic-Add'l	Incremental Charge - Manual Svc Order vs. Electronic-Disc 1st	Incremental Charge - Manual Svc Order vs. Electronic-Disc Add'l
						Rec	Nonrecurring		Nonrecurring Disconnect						
							First	Add'l	First	Add'l	SOMEc	SOMAN	SOMAN	SOMAN	SOMAN
	4-Wire Copper Loop/Short - without manual service inquiry and facility reservation - Zone 2		2	UCL	UCL4W	17.36	149.52	97.33	74.95	14.69		7.86			
	4-Wire Copper Loop/Short - without manual service inquiry and facility reservation - Zone 3		3	UCL	UCL4W	28.10	149.52	97.33	74.95	14.69		7.86			
	Order Coordination for Unbundled Copper Loops (per loop)			UCL	UCLMC		9.00	9.00							
	4-Wire Unbundled Copper Loop/Long - includes manual svc. inquiry and facility reservation - Zone 1		1	UCL	UCL4L	46.91	170.31	108.06	74.95	14.69		7.86			
	4-Wire Unbundled Copper Loop/Long - includes manual svc. inquiry and facility reservation - Zone 2		2	UCL	UCL4L	45.78	170.31	108.06	74.95	14.69		7.86			
	4-Wire Unbundled Copper Loop/Long - includes manual svc. inquiry and facility reservation - Zone 3		3	UCL	UCL4L	171.34	170.31	108.06	74.95	14.69		7.86			
	Order Coordination for Unbundled Copper Loops (per loop)			UCL	UCLMC		9.00	9.00							
	4-Wire Unbundled Copper Loop/Long - without manual svc. inquiry and facility reservation - Zone 1		1	UCL	UCL4O	46.91	149.52	97.33	74.95	14.69		7.86			
	4-Wire Unbundled Copper Loop/Long - without manual svc. inquiry and facility reservation - Zone 2		2	UCL	UCL4O	45.78	149.52	97.33	74.95	14.69		7.86			
	4-Wire Unbundled Copper Loop/Long - without manual svc. inquiry and facility reservation - Zone 3		3	UCL	UCL4O	171.34	149.52	97.33	74.95	14.69		7.86			
	Order Coordination for Unbundled Copper Loops (per loop)			UCL	UCLMC		9.00	9.00							
	CLEC to CLEC Conversion Charge without outside dispatch (UCL-Des)			UCL	UREWO		97.23	42.48				7.86			
<b>LOOP MODIFICATION</b>															
	Unbundled Loop Modification, Removal of Load Coils - 2 Wire pair less than or equal to 18k ft			UAL, UHL, UCL, UEQ, ULS, UEA, UEANL, UEPSR, UEPSB	ULM2L		9.24	9.24				7.86			
	Unbundled Loop Modification, Removal of Load Coils - 2 wire greater than 18k ft			UCL, ULS, UEQ	ULM2G		342.24	342.24				7.86			
	Unbundled Loop Modification Removal of Load Coils - 4 Wire less than or equal to 18K ft			UHL, UCL, UEA	ULM4L		9.24	9.24				7.86			
	Unbundled Loop Modification Removal of Load Coils - 4 Wire pair greater than 18k ft			UCL	ULM4G		342.24	342.24				7.86			
	Unbundled Loop Modification Removal of Bridged Tap Removal, per unbundled loop			UAL, UHL, UCL, UEQ, ULS, UEA, UEANL, UEPSR, UEPSB	ULMBT		10.47	10.47				7.86			
<b>SUB-LOOPS</b>															
<b>Sub-Loop Distribution</b>															
	Sub-Loop - Per Cross Box Location - CLEC Feeder Facility Set-Up		I	UEANL	USBSA		207.91	207.91				7.86			
	Sub-Loop - Per Cross Box Location - Per 25 Pair Panel Set-Up		I	UEANL	USBSB		12.50	12.50				7.86			
	Sub-Loop - Per Building Equipment Room - CLEC Feeder Facility Set-Up		I	UEANL	USBSC		80.87	80.87				7.86			
	Sub-Loop - Per Building Equipment Room - Per 25 Pair Panel Set-Up		I	UEANL	USBSD		45.04	45.04				7.86			
	Sub-Loop Distribution Per 2-Wire Analog Voice Grade Loop - Zone 1		I	1	UEANL	USBN2	6.34	85.03	39.05	59.81	7.90	7.86			
	Sub-Loop Distribution Per 2-Wire Analog Voice Grade Loop - Zone 2		I	2	UEANL	USBN2	9.06	85.03	39.05	59.81	7.90	7.86			
	Sub-Loop Distribution Per 2-Wire Analog Voice Grade Loop - Zone 3		I	3	UEANL	USBN2	14.82	85.03	39.05	59.81	7.90	7.86			
	Order Coordination for Unbundled Sub-Loops, per sub-loop pair			UEANL	USBMC		9.00	9.00							
	Sub-Loop Distribution Per 4-Wire Analog Voice Grade Loop - Zone 1		1	UEANL	USBN4	8.14	102.31	56.32	65.24	10.88		7.86			
	Sub-Loop Distribution Per 4-Wire Analog Voice Grade Loop - Zone 2		2	UEANL	USBN4	8.63	102.31	56.32	65.24	10.88		7.86			

UNBUNDLED NETWORK ELEMENTS - Kentucky											Attachment: 2		Exhibit: B										
CATEGORY	RATE ELEMENTS	Interim	Zone	BCS	USOC	RATES (\$)	Svc Order Submitted Elec per LSR	Svc Order Submitted Manually per LSR	Incremental Charge - Manual Svc Order vs. Electronic-1st	Incremental Charge - Manual Svc Order vs. Electronic-Add'l	Incremental Charge - Manual Svc Order vs. Electronic-Disc 1st	Incremental Charge - Manual Svc Order vs. Electronic-Disc Add'l	OSS Rates(\$)										
													Rec	Nonrecurring		Nonrecurring Disconnect		SOMEc	SOMAN	SOMAN	SOMAN	SOMAN	SOMAN
													First	Add'l	First	Add'l							
	Sub-Loop Distribution Per 4-Wire Analog Voice Grade Loop - Zone 3		3	UEANL	USBN4	25.60							102.31	56.32	65.24	10.88			7.86				
	Order Coordination for Unbundled Sub-Loops, per sub-loop pair			UEANL	USBMC								9.00	9.00									
	Sub-Loop 2-Wire Intrabuilding Network Cable (INC)	I		UEANL	USBR2	2.57							68.35	22.36	59.81	7.90			7.86				
	Order Coordination for Unbundled Sub-Loops, per sub-loop pair			UEANL	USBMC								9.00	9.00									
	Sub-Loop 4-Wire Intrabuilding Network Cable (INC)	I		UEANL	USBR4	4.98							76.49	30.51	65.24	10.88			7.86				
	Order Coordination for Unbundled Sub-Loops, per sub-loop pair			UEANL	USBMC								9.00	9.00									
	2 Wire Copper Unbundled Sub-Loop Distribution - Zone 1	I	1	UEF	UCS2X	5.45							85.03	39.05	59.81	7.90			7.86				
	2 Wire Copper Unbundled Sub-Loop Distribution - Zone 2	I	2	UEF	UCS2X	7.06							85.03	39.05	59.81	7.90			7.86				
	2 Wire Copper Unbundled Sub-Loop Distribution - Zone 3	I	3	UEF	UCS2X	9.67							85.03	39.05	59.81	7.90			7.86				
	Order Coordination for Unbundled Sub-Loops, per sub-loop pair			UEF	USBMC								9.00	9.00									
	4 Wire Copper Unbundled Sub-Loop Distribution - Zone 1	I	1	UEF	UCS4X	7.09							102.31	56.32	65.24	10.88			7.86				
	4 Wire Copper Unbundled Sub-Loop Distribution - Zone 2	I	2	UEF	UCS4X	8.66							102.31	56.32	65.24	10.88			7.86				
	4 Wire Copper Unbundled Sub-Loop Distribution - Zone 3	I	3	UEF	UCS4X	19.40							102.31	56.32	65.24	10.88			7.86				
	Order Coordination for Unbundled Sub-Loops, per sub-loop pair			UEF	USBMC								9.00	9.00									
	<b>Unbundled Network Terminating Wire (UNTW)</b>																						
	Unbundled Network Terminating Wire (UNTW) per Pair			UENTW	UENPP	0.53							23.51	23.51					7.86				
	<b>Network Interface Device (NID)</b>																						
	Network Interface Device (NID) - 1-2 lines			UENTW	UND12								73.53	49.47					7.86				
	Network Interface Device (NID) - 1-6 lines			UENTW	UND16								115.96	91.91					7.86				
	Network Interface Device Cross Connect - 2 W			UENTW	UNDC2								8.56	8.56					7.86				
	Network Interface Device Cross Connect - 4W			UENTW	UNDC4								8.56	8.56					7.86				
	<b>SUB-LOOPS</b>																						
	<b>Sub-Loop Feeder</b>																						
	USL-Feeder, DS0 Set-up per Cross Box location - CLEC Distribution Facility set-up			UEA, UDN,UCL,UDL,UDC	USBFW								207.91						7.86				
	USL Feeder - DS0 Set-up per Cross Box location - per 25 pair set-up			UEA, UDN,UCL,UDL,UDC	USBFX								12.50	12.50					7.86				
	USL Feeder DS1 Set-up at DSX location, per DS1 termination			USL	USBFZ								527.98	11.32					7.86				
	Unbundled Sub-Loop Feeder Loop, 2 Wire Ground Start, Voice Grade - Zone 1		1	UEA	USBFA	7.67							114.83	64.61	72.34	17.21			7.86				
	Unbundled Sub-Loop Feeder Loop, 2 Wire Ground-Start, Voice Grade - Zone 2		2	UEA	USBFA	9.70							114.83	64.61	72.34	17.21			7.86				
	Unbundled Sub-Loop Feeder Loop, Per 2 Wire Ground-Start, Voice Grade - Zone 3		3	UEA	USBFA	19.53							114.83	64.61	72.34	17.21			7.86				
	Order Coordination for Specified Conversion Time, per LSR			UEA	OCOSL								23.01										
	Unbundle Sub-Loop Feeder Loop, 2 Wire Loop-Start, Voice Grade - Zone 1		1	UEA	USBFB	7.67							114.83	64.61	72.34	17.21			7.86				
	Unbundled Sub-Loop Feeder Loop, 2 Wire Loop-Start, Voice Grade - Zone 2		2	UEA	USBFB	9.70							114.83	64.61	72.34	17.21			7.86				
	Unbundled Sub-Loop Feeder Loop, 2 Wire Start Loop, Voice Grade - Zone 3		3	UEA	USBFB	19.53							114.83	64.61	72.34	17.21			7.86				
	Order Coordination for Specified Time Conversion, per LSR			UEA	OCOSL								23.01										
	Unbundled Sub-Loop Feeder Loop, 2 Wire Reverse Battery, Voice Grade - Zone 1		1	UEA	USBFC	7.67							114.83	64.61	72.34	17.21			7.86				
	Unbundled Sub-Loop Feeder Loop, 2 Wire Reverse Battery, Voice Grade - Zone 2		2	UEA	USBFC	9.70							114.83	64.61	72.34	17.21			7.86				
	Unbundled Sub-Loop Feeder Loop, 2 Wire Analog Reverse Battery, Voice Grade - Zone 3		3	UEA	USBFC	19.53							114.83	64.61	72.34	17.21			7.86				
	Order Coordination For Specified Conversion Time, per LSR			UEA	OCOSL								23.01										
	Unbundled Sub-Loop Feeder Loop, 4 Wire Ground-Start, Voice Grade - Zone 1		1	UEA	USBFD	22.82							131.73	79.98	81.82	51.56			7.86				
	Unbundled Sub-Loop Feeder Loop, 4 Wire Ground-Start, Voice Grade - Zone 2		2	UEA	USBFD	27.24							131.73	79.98	81.82	51.56			7.86				

UNBUNDLED NETWORK ELEMENTS - Kentucky												Attachment: 2		Exhibit: B							
CATEGORY	RATE ELEMENTS	Interim	Zone	BCS	USOC	RATES (\$)	Svc Order Submitted Elec per LSR	Svc Order Submitted Manually per LSR	Incremental Charge - Manual Svc Order vs. Electronic-1st	Incremental Charge - Manual Svc Order vs. Electronic-Add'l	Incremental Charge - Manual Svc Order vs. Electronic-Disc 1st	Incremental Charge - Manual Svc Order vs. Electronic-Disc Add'l	OSS Rates(\$)								
													Rec	Nonrecurring		Nonrecurring Disconnect		SOMEc	SOMAN	SOMAN	SOMAN
													First	Add'l	First	Add'l					
	Unbundled Sub-Loop Feeder Loop, 4 Wire Ground Start, Voice Grade - Zone 3		3	UEA	USBFD	61.41	131.73	79.98	81.82	51.56											
	Order Coordination For Specified Conversion Time, Per LSR			UEA	OCOSL		23.01														
	Unbundled Sub-Loop Feeder Loop, 4 Wire Loop-Start, Voice Grade - Zone 1		1	UEA	USBFE	22.82	131.73	79.98	81.82	51.56											
	Unbundled Sub-Loop Feeder Loop, 4 Wire Loop-Start, Voice Grade - Zone 2		2	UEA	USBFE	27.24	131.73	79.98	81.82	51.56											
	Unbundled Sub-Loop Feeder Loop, 4 Wire Loop-Start, Voice Grade - Zone 3		3	UEA	USBFE	61.41	131.73	79.98	81.82	51.56											
	Order Coordination For Specified Conversion Time, Per LSR			UEA	OCOSL		23.01														
	Unbundled Sub-Loop Feeder Loop, 2 Wire ISDN BRI - Zone 1		1	UDN	USBFF	13.00	131.79	80.04	74.16	16.60											
	Unbundled Sub-Loop Feeder Loop, 2-Wire ISDN BRI - Zone 2		2	UDN	USBFF	16.95	131.79	80.04	74.16	16.60											
	Unbundled Sub-Loop Feeder Loop, 2-Wire ISDN BRI - Zone 3		3	UDN	USBFF	28.95	131.79	80.04	74.16	16.60											
	Order Coordination For Specified Conversion Time, Per LSR			UDN	OCOSL		23.01														
	Unbundled Sub-Loop Feeder, 2 Wire UDC (IDSL compatible)		1	UDC	USBFS	13.00	131.79	80.04	74.16	16.60											
	Unbundled Sub-Loop Feeder, 2 Wire UDC (IDSL compatible)		2	UDC	USBFS	16.95	131.79	80.04	74.16	16.60											
	Unbundled Sub-Loop Feeder, 2 Wire UDC (IDSL compatible)		3	UDC	USBFS	28.95	131.79	80.04	74.16	16.60											
	Unbundled Sub-Loop Feeder Loop, 4-Wire DS1 - Zone 1		1	USL	USBFG	62.57	125.43	73.68	81.82	21.56											
	Unbundled Sub-Loop Feeder Loop, 4-Wire DS1 - Zone 2		2	USL	USBFG	87.71	125.43	73.68	81.82	21.56											
	Unbundled Sub-Loop Feeder Loop, 4-Wire DS1 - Zone 3		3	USL	USBFG	273.33	125.43	73.68	81.82	21.56											
	Order Coordination For Specified Conversion Time, Per LSR			USL	OCOSL		23.01														
	Unbundled Sub-Loop Feeder, 2-Wire Copper Loop - Zone 1		1	UCL	USBFH	6.44	105.31	53.57	71.16	13.61											
	Unbundled Sub-Loop Feeder Loop, 2-Wire Copper Loop - Zone 2		2	UCL	USBFH	5.78	105.31	53.57	71.16	13.61											
	Unbundled Sub-Loop Feeder Loop, 2-Wire Copper Loop - Zone 3		3	UCL	USBFH	4.25	105.31	53.57	71.16	13.61											
	Order Coordination For Specified Conversion Time, per LSR			UCL	OCOSL		23.01														
	Sub-Loop Feeder - Per 4-Wire Copper Loop - Zone 1		1	UCL	USBFJ	11.33	125.55	73.80	77.12	16.86											
	Sub-Loop Feeder - Per 4-Wire Copper Loop - Zone 2		2	UCL	USBFJ	10.18	125.55	73.80	77.12	16.86											
	Sub-Loop Feeder - Per 4-Wire Copper Loop - Zone 3		3	UCL	USBFJ	10.32	125.55	73.80	77.12	16.86											
	Order Coordination For Specified Conversion Time, per LSR			UCL	OCOSL		23.01														
	Sub-Loop Feeder - Per 4-Wire 19.2 Kbps Digital Grade Loop		1	UDL	USBFN	20.78	125.43	73.68	81.82	21.56											
	Sub-Loop Feeder - Per 4-Wire 19.2 Kbps Digital Grade Loop		2	UDL	USBFN	26.41	125.43	73.68	81.82	21.56											
	Sub-Loop Feeder - Per 4-Wire 19.2 Kbps Digital Grade Loop		3	UDL	USBFN	23.10	125.43	73.68	81.82	21.56											
	Sub-Loop Feeder - Per 4-Wire 56 Kbps Digital Grade Loop - Zone 1		1	UDL	USBFO	20.78	125.43	73.68	81.82	21.56											
	Sub-Loop Feeder - Per 4-Wire 56 Kbps Digital Grade Loop - Zone 2		2	UDL	USBFO	26.41	125.43	73.68	81.82	21.56											
	Sub-Loop Feeder - Per 4-Wire 56 Kbps Digital Grade Loop - Zone 3		3	UDL	USBFO	23.10	125.43	73.68	81.82	21.56											
	Order Coordination For Specified Time Conversion, per LSR			UDL	OCOSL		23.01														
	Sub-Loop Feeder - Per 4-Wire 64 Kbps Digital Grade Loop - Zone 1		1	UDL	USBFP	20.78	125.43	73.68	81.82	21.56											
	Sub-Loop Feeder - Per 4-Wire 64 Kbps Digital Grade Loop - Zone 2		2	UDL	USBFP	26.41	125.43	73.68	81.82	21.56											
	Sub-Loop Feeder - Per 4-Wire 64 Kbps Digital Grade Loop - Zone 3		3	UDL	USBFP	23.10	125.43	73.68	81.82	21.56											
	Order Coordination For Specified Conversion Time, per LSR			UDL	OCOSL		23.01														
<b>SUB-LOOPS</b>																					
<b>Sub-Loop Feeder</b>																					
	Sub Loop Feeder - DS3 - Per Mile Per Month		I	UE3	1L5SL	15.38															
	Sub Loop Feeder - DS3 - Facility Termination Per Month		I	UE3	USBF1	346.30	3,402.59	407.14	160.86	91.19											
	Sub Loop Feeder - STS-1 - Per Mile Per Month		I	UDLSX	1L5SL	15.38															
	Sub Loop Feeder - STS-1 - Facility Termination Per Month		I	UDLSX	USBF7	372.80	3,402.59	407.14	160.86	91.19											
<b>UNBUNDLED LOOP CONCENTRATION</b>																					
	Unbundled Loop Concentration - System A (TR008)			ULC	UCT8A	423.72	359.34	359.34													
	Unbundled Loop Concentration - System B (TR008)			ULC	UCT8B	51.60	149.72	149.72													
	Unbundled Loop Concentration - System A (TR303)			ULC	UCT3A	460.27	359.34	359.34													
	Unbundled Loop Concentration - System B (TR303)			ULC	UCT3B	86.95	149.72	149.72													

UNBUNDLED NETWORK ELEMENTS - Kentucky										Attachment: 2		Exhibit: B						
CATEGORY	RATE ELEMENTS	Interim	Zone	BCS	USOC	RATES (\$)	Svc Order Submitted Elec per LSR	Svc Order Submitted Manually per LSR	Incremental Charge - Manual Svc Order vs. Electronic-1st	Incremental Charge - Manual Svc Order vs. Electronic-Add'l	Incremental Charge - Manual Svc Order vs. Electronic-Disc 1st	Incremental Charge - Manual Svc Order vs. Electronic-Disc Add'l	OSS Rates(\$)					
													Rec	Nonrecurring		Nonrecurring Disconnect		SOMEC
							First	Add'l	First	Add'l								
	Unbundled Loop Concentration - DS1 Loop Interface Card			ULC	UCTCO	4.90	71.69	51.51	22.99	6.00		7.86						
	Unbundled Loop Concentration - ISDN Loop Interface (Brite Card)			UDN	ULCC1	7.78	16.59	16.50	8.42	8.37		7.86						
	Unbundled Loop Concentration - UDC Loop Interface (Brite Card)			UDC	ULCCU	7.78	16.59	16.50	8.42	8.37		7.86						
	Unbundled Loop Concentration - -2 Wire Voice-Loop Start or Ground Start Loop Interface (POTS Card)			UEA	ULCC2	1.95	16.59	16.50	8.42	8.37		7.86						
	Unbundled Loop Concentration - 2 Wire Voice - Reverse Battery Loop Interface (SPOTS Card)			UEA	ULCCR	11.58	16.59	16.50	8.42	8.37		7.86						
	Unbundled Loop Concentration - 4 Wire Voice Loop Interface (Specials Card)			UEA	ULCC4	6.90	16.59	16.50	8.42	8.37		7.86						
	Unbundled Loop Concentration - TEST CIRCUIT Card			ULC	UCTTC	33.74	16.59	16.50	8.42	8.37		7.86						
	Unbundled Loop Concentration - Digital 19.2 Kbps Data Loop Interface			UDL	ULCC7	10.23	16.59	16.50	8.42	8.37		7.86						
	Unbundled Loop Concentration - Digital 56 Kbps Data Loop Interface			UDL	ULCC5	10.23	16.59	16.50	8.42	8.37		7.86						
	Unbundled Loop Concentration - Digital 64 Kbps Data Loop Interface			UDL	ULCC6	10.23	16.59	16.50	8.42	8.37		7.86						
<b>UNE OTHER, PROVISIONING ONLY - NO RATE</b>																		
	NID - Dispatch and Service Order for NID installation			UENTW	UNDBX	0.00	0.00											
	UNTW Circuit Id Establishment, Provisioning Only - No Rate			UENTW	UENCE	0.00	0.00											
	Unbundled Contract Name, Provisioning Only - No Rate			UEANL,UEF,UEQ,UENTW	UNECN	0.00	0.00											
<b>UNE OTHER, PROVISIONING ONLY - NO RATE</b>																		
	Unbundled Contact Name, Provisioning Only - no rate			UAL,UCL,UDC,UDL,UDN,UEA,UHL,ULC	UNECN	0.00	0.00											
	Unbundled Sub-Loop Feeder-2 Wire Cross Box Jumper - no rate			UEA,UDN,UCL,UDC	USBFQ	0.00	0.00											
	Unbundled Sub-Loop Feeder-4 Wire Cross Box Jumper - no rate			UEA,USL,UCL,UDL	USBFR	0.00	0.00											
	Unbundled DS1 Loop - Superframe Format Option - no rate			USL	CCOSF	0.00	0.00											
	Unbundled DS1 Loop - Expanded Superframe Format option - no rate			USL	CCOEF	0.00	0.00											
<b>HIGH CAPACITY UNBUNDLED LOCAL LOOP</b>																		
<b>NOTE: minimum billing period of three months for DS3/STS-1 Local Loop</b>																		
	High Capacity Unbundled Local Loop - DS3 - Per Mile per month			UE3	1L5ND	9.25												
	High Capacity Unbundled Local Loop - DS3 - Facility Termination per month			UE3	UE3PX	308.31	551.38	338.08	173.00	120.42		7.86						
	High Capacity Unbundled Local Loop - STS-1 - Per Mile per month			UDLSX	1L5ND	9.25												
	High Capacity Unbundled Local Loop - STS-1 - Facility Termination per month			UDLSX	UDLS1	320.51	551.38	338.08	173.00	120.42		7.86						
<b>LOOP MAKE-UP</b>																		
	Loop Makeup - Preordering Without Reservation, per working or spare facility queried (Manual).			UMK	UMKLV		23.40	23.40										
	Loop Makeup - Preordering With Reservation, per spare facility queried (Manual).			UMK	UMKLP		24.85	24.85										
<b>HIGH FREQUENCY SPECTRUM</b>																		
<b>LINE SHARING</b>																		
<b>SPLITTERS-CENTRAL OFFICE BASED</b>																		
	Line Sharing Splitter, per System 96 Line Capacity			ULS	ULSDA	198.83	379.05	0.00	358.55	0.00		7.86						
	Line Sharing Splitter, per System 24 Line Capacity			ULS	ULSDB	49.71	379.05	0.00	358.55	0.00		7.86						
	Line Sharing Splitter, Per System, 8 Line Capacity			ULS	ULSD8	16.94	377.71	0.00	357.29	0.00		7.86						
	Line Sharing-DLEC Owned Splitter in CO-CFA activation-deactivation (per LSOD)			ULS	ULSDG		173.62	0.00	100.40	0.00		7.86						
<b>END USER ORDERING-CENTRAL OFFICE BASED-HIGH FREQUENCY SPECTRUM AKA LINE SHARING</b>																		
	Line Sharing - per Line Activation (BST Owned Splitter)			ULS	ULSDC	0.61	37.16	21.28	20.17	9.90		7.86						

UNBUNDLED NETWORK ELEMENTS - Kentucky							Attachment: 2		Exhibit: B							
CATEGORY	RATE ELEMENTS	Interim	Zone	BCS	USOC	RATES (\$)	Svc Order Submitted Elec per LSR	Svc Order Submitted Manually per LSR	Incremental Charge - Manual Svc Order vs. Electronic-1st	Incremental Charge - Manual Svc Order vs. Electronic-Add'l	Incremental Charge - Manual Svc Order vs. Electronic-Disc 1st	Incremental Charge - Manual Svc Order vs. Electronic-Disc Add'l				
													Rec	Nonrecurring		Nonrecurring Disconnect
										SOMEc	SOMAN	SOMAN	SOMAN	SOMAN	SOMAN	
	Line Sharing - per Subsequent Activity per Line Rearrangement(BST Owned Splitter)			ULS	ULSDS						7.86					
	Line Sharing - per Subsequent Activity per Line Rearrangement(DLEC Owned Splitter)			ULS	ULSCS						7.86					
	Line Sharing - per Line Activation (DLEC owned Splitter)	I		ULS	ULSCC	0.61	47.44	19.31	20.67	12.74	7.86					
<b>LINE SPLITTING</b>																
<b>END USER ORDERING-CENTRAL OFFICE BASED</b>																
	Line Splitting - per line activation DLEC owned splitter	I		UEPSR UEPSB	UREOS	0.61										
	Line Splitting - per line activation BST owned - physical	I		UEPSR UEPSB	UREBP	0.61	37.02	21.20	21.10	9.87	7.86					
	Line Splitting - per line activation BST owned - virtual	I		UEPSR UEPSB	UREBV	0.61	37.02	21.20	21.10	9.87	7.86					
<b>REMOTE SITE HIGH FREQUENCY SPECTRUM</b>																
<b>SPLITTERS-REMOTE SITE</b>																
	Remote Site Line Share BellSouth Owned Splitter, 24 Port	I		ULS	ULSRB	38.55	114.83	0.00	84.55	0.00	7.86					
	Remote Site Line Share Cable Pair Activation CLEC Owned at RS and Deactivation	I		ULS	ULSTG		95.65	0.00	67.87	0.00	7.86					
<b>END USER ORDERING-REMOTE SITE HIGH FREQUENCY SPECTRUM AKA REMOTE SITE LINE SHARING</b>																
	Remote Site Line Share Line Activationfor End User Served at RS, BST Splitter	I		ULS	ULSRC	0.61	37.16	21.28	20.17	9.90	7.86					
	RS Line Share Line Activation for End User served at RS, CLEC Splitter	I		ULS	ULSTC	0.61	37.16	21.28	20.17	9.90	7.86					
	Remote Site Line Share Subsequent Activity-RS BST Owned Splitter	I		ULS	ULSRS		49.16	17.83			7.86					
	Remote Site Line Share Subsequent Activity-RS CLEC Owned Splitter	I		ULS	ULSTS		49.16	17.83			7.86					
<b>UNBUNDLED DEDICATED TRANSPORT</b>																
<b>NOTE: INTEROFFICE CHANNEL DEDICATED TRANSPORT - minimum billing period - below DS3=one month, DS3/STS-1=four months</b>																
<b>INTEROFFICE CHANNEL - DEDICATED TRANSPORT</b>																
	Interoffice Channel - Dedicated Transport - 2-Wire Voice Grade - Per Mile per month			U1TVX	1L5XX	0.01										
	Interoffice Channel - Dedicated Transport- 2- Wire Voice Grade - Facility Termination			U1TVX	U1TV2	29.11	47.34	31.78	22.77	8.75	7.86					
	Interoffice Channel - Dedicated Transport- 2-Wire Voice Grade Rev Bat. - Per Mile per month			U1TVX	1L5XX	0.01										
	Interoffice Channel - Dedicated Transport- 2- Wire VG Rev Bat. - Facility Termination			U1TVX	U1TR2	29.11	47.34	31.78	22.77	8.75	7.86					
	Interoffice Channel - Dedicated Transport - 4-Wire Voice Grade - Per Mile per month			U1TVX	1L5XX	0.01										
	Interoffice Channel - Dedicated Transport - 4- Wire Voice Grade - Facility Termination			U1TVX	U1TV4	25.86	47.34	31.78	22.77	8.75	7.86					
	Interoffice Channel - Dedicated Transport - 56 kbps - per mile per month			U1TDX	1L5XX	0.0115										
	Interoffice Channel - Dedicated Transport - 56 kbps - Facility Termination			U1TDX	U1TD5	20.97	47.35	31.78	22.77	8.75	7.86					
	Interoffice Channel - Dedicated Transport - 64 kbps - per mile per month			U1TDX	1L5XX	0.0115										
	Interoffice Channel - Dedicated Transport - 64 kbps - Facility Termination			U1TDX	U1TD6	20.97	47.35	31.78	22.77	8.75	7.86					
	Interoffice Channel - Dedicated Channel - DS1 - Per Mile per month			U1TD1	1L5XX	0.23										
	Interoffice Channel - Dedicated Transport - DS1 - Facility Termination			U1TD1	U1TF1	96.04	105.52	98.46	23.09	20.49	7.86					
	Interoffice Channel - Dedicated Transport - DS3 - Per Mile per month			U1TD3	1L5XX	4.97										
	Interoffice Channel - Dedicated Transport - DS3 - Facility Termination per month			U1TD3	U1TF3	1,175.15	335.40	219.24	89.57	87.75	7.86					
	Interoffice Channel - Dedicated Transport - STS-1 - Per Mile per month			U1TS1	1L5XX	4.97										
	Interoffice Channel - Dedicated Transport - STS-1 - Facility Termination			U1TS1	U1TFS	1,149.51	335.40	219.24	89.57	87.75	7.86					

UNBUNDLED NETWORK ELEMENTS - Kentucky								Attachment: 2		Exhibit: B						
CATEGORY	RATE ELEMENTS	Interim	Zone	BCS	USOC	RATES (\$)	Svc Order Submitted Elec per LSR	Svc Order Submitted Manually per LSR	Incremental Charge - Manual Svc Order vs. Electronic-1st	Incremental Charge - Manual Svc Order vs. Electronic-Add'l	Incremental Charge - Manual Svc Order vs. Electronic-Disc 1st	Incremental Charge - Manual Svc Order vs. Electronic-Disc Add'l				
							Rec	Nonrecurring		Nonrecurring Disconnect		OSS Rates(\$)				
							First	Add'l	First	Add'l	SOME C	SOMAN	SOMAN	SOMAN	SOMAN	SOMAN
<b>LOCAL CHANNEL - DEDICATED TRANSPORT</b>																
<b>NOTE: LOCAL CHANNEL DEDICATED TRANSPORT - minimum billing period = below DS3=one month, DS3/STS-1=four months</b>																
	Local Channel - Dedicated - 2-Wire Voice Grade			ULDVX	ULDV2	18.57	265.78	46.96	46.79	4.98		7.86				
	Local Channel - Dedicated - 2-Wire Voice Grade Rev Bat			ULDVX	ULDVR2	18.57	265.78	46.96	46.79	4.98		7.86				
	Local Channel - Dedicated - 4-Wire Voice Grade			ULDVX	ULDV4	19.86	266.48	47.65	47.54	5.73		7.86				
	Local Channel - Dedicated - DS1 - Zone 1		1	ULDD1	ULDF1	40.46	209.60	176.51	30.21	21.07		7.86				
	Local Channel - Dedicated - DS1 - Zone 2		2	ULDD1	ULDF1	43.39	209.60	176.51	30.21	21.07		7.86				
	Local Channel - Dedicated - DS1 - Zone 3		3	ULDD1	ULDF1	164.50	209.60	176.51	30.21	21.07		7.86				
	Local Channel - Dedicated - DS3 - Per Mile per month			ULDD3	1L5NC	8.74										
	Local Channel - Dedicated - DS3 - Facility Termination			ULDD3	ULDF3	576.05	551.38	338.08	173.00	120.42		7.86				
	Local Channel - Dedicated - STS-1- Per Mile per month			ULDS1	1L5NC	8.74										
	Local Channel - Dedicated - STS-1 - Facility Termination			ULDS1	ULDFS	543.24	551.38	338.08	173.00	120.42		7.86				
<b>DARK FIBER</b>																
	Dark Fiber, Four Fiber Strands, Per Route Mile or Fraction Thereof per month - Local Channel			UDF	1L5DC	47.01										
	NRC Dark Fiber - Local Channel			UDF	UDFC4		732.53	192.67	377.27	241.67		7.86				
	Dark Fiber, Four Fiber Strands, Per Route Mile or Fraction Thereof per month - Interoffice Channel			UDF	1L5DF	30.74										
	NRC Dark Fiber - Interoffice Channel			UDF	UDF14		732.53	192.67	377.27	241.67		7.86				
	Dark Fiber, Four Fiber Strands, Per Route Mile or Fraction Thereof per month - Local Loop			UDF	1L5DL	47.01										
	NRC Dark Fiber - Local Loop			UDF	UDFL4		732.53	192.67	377.27	241.67		7.86				
<b>8XX ACCESS TEN DIGIT SCREENING</b>																
	8XX Access Ten Digit Screening, Per Call			OHD		0.0006478										
	8XX Access Ten Digit Screening, Reservation Charge Per 8XX Number Reserved			OHD	N8R1X		4.14	0.70				7.86				
	8XX Access Ten Digit Screening, Per 8XX No. Established W/O POTS Translations			OHD			8.78	1.18	7.08	0.86		7.86				
	8XX Access Ten Digit Screening, Per 8XX No. Established With POTS Translations			OHD	N8FTX		8.78	1.18	7.08	0.86		7.86				
	8XX Access Ten Digit Screening, Customized Area of Service Per 8XX Number			OHD	N8FCX		4.14	2.07				7.86				
	8XX Access Ten Digit Screening, Multiple InterLATA CXR Routing Per CXR Requested Per 8XX No.			OHD	N8FMX		4.85	2.78				7.86				
	8XX Access Ten Digit Screening, Change Charge Per Request			OHD	N8FAX		4.85	0.70				7.86				
	8XX Access Ten Digit Screening, Call Handling and Destination Features			OHD	N8FDX		4.14	4.14				7.86				
	8XX Access Ten Digit Screening w/ 8FL No. Delivery,			OHD		0.0006478										
	8XX Access Ten Digit Screening, w/ POTS No. Delivery,			OHD		0.0006478										
<b>LINE INFORMATION DATA BASE ACCESS (LIDB)</b>																
	LIDB Common Transport Per Query			OQT		0.000023										
	LIDB Validation Per Query			OQU		0.0137322										
	LIDB Originating Point Code Establishment or Change			OQT, OQU	NRPBX		55.12		67.59			7.86				
<b>SIGNALING (CCS7)</b>																
	CCS7 Signaling Connection, Per 56 Kbps Facility			UDB	TPP++	20.71	43.56	43.56	22.45	22.45						
	CCS7 Signaling Termination, Per STP Port			UDB	PT8SX	151.39										
	CCS7 Signaling Usage, Per TCAP Message			UDB		0.0000656										
	CCS7 Signaling Connection, Per link (A link)			UDB	TPP++	20.71	43.56	43.56	22.45	22.45		7.86				
	CCS7 Signaling Connection, Per link (B link) (also known as D link)			UDB	TPP++	20.71	43.56	43.56	22.45	22.45		7.86				
	CCS7 Signaling Usage, Per ISUP Message			UDB		0.0000164										
	CCS7 Signaling Usage Surrogate, per link per LATA			UDB	STU56	751.08										
	CCS7 Signaling Point Code, per Originating Point Code Establishment or Change, per STP affected			UDB	CCAPO		46.02	46.02	56.43	56.43		7.86				
	CCS7 Signaling Point Code, per Destination Point Code Establishment or Change, Per Stp Affected			UDB	CCAPD		46.02	46.02	56.43	56.43		7.86				
<b>E911 SERVICE</b>																
	Local Channel - Dedicated - 2-wr Voice Grade					18.57	265.78	46.96	46.79	4.98		7.86				
	Interoffice Transport - Dedicated - 2-wr Voice Grade Per Mile					0.0115										

UNBUNDLED NETWORK ELEMENTS - Kentucky							Attachment: 2		Exhibit: B			
CATEGORY	RATE ELEMENTS	Interim	Zone	BCS	USOC	RATES (\$)	Svc Order Submitted Elec per LSR	Svc Order Submitted Manually per LSR	Incremental Charge - Manual Svc Order vs. Electronic-1st	Incremental Charge - Manual Svc Order vs. Electronic-Add'l	Incremental Charge - Manual Svc Order vs. Electronic-Disc 1st	Incremental Charge - Manual Svc Order vs. Electronic-Disc Add'l
	Interoffice Transport - Dedicated - 2-wr Voice Grade Per Facility Termination					29.11						
	Local Channel - Dedicated - DS1 - Zone 1					40.46						
	Local Channel - Dedicated - DS1 - Zone 2					43.39						
	Local Channel - Dedicated - DS1 - Zone 3					164.50						
	Interoffice Transport - Dedicated - DS1 Per Mile					0.23						
	Interoffice Transport - Dedicated - DS1 Per Facility Termination					96.04						
<b>CALLING NAME (CNAM) SERVICE</b>												
	CNAM For DB Owners - Service Establishment					25.34						
	CNAM For Non DB Owners - Service Establishment					25.34						
	CNAM For DB Owners - Service Provisioning With Point Code Establishment					1,591.54						
	CNAM For Non DB Owners - Service Provisioning With Point Code Establishment					546.40						
	CNAM for DB Owners, Per Query					0.0010348						
	CNAM for Non DB Owners, Per Query					0.0010348						
	CNAM (Non-Databs Owner), NRC, applies when using the Character Based User Interface (CHUI)					595.00						
<b>LNP Query Service</b>												
	LNP Charge Per query					0.0008695						
	LNP Service Establishment Manual					13.82						
	LNP Service Provisioning with Point Code Establishment					953.27						
<b>OPERATOR CALL PROCESSING</b>												
	Oper. Call Processing - Oper. Provided, Per Min. - Using BST LIDB					1.20						
	Oper. Call Processing - Oper. Provided, Per Min. - Using Foreign LIDB					1.24						
	Oper. Call Processing - Fully Automated, per Call - Using BST LIDB					0.20						
	Oper. Call Processing - Fully Automated, per Call - Using Foreign LIDB					0.20						
<b>INWARD OPERATOR SERVICES</b>												
	Inward Operator Services - Verification, Per Call					1.00						
	Inward Operator Services - Verification and Emergency Interrupt - Per Call					1.95						
<b>BRANDING - OPERATOR CALL PROCESSING</b>												
<b>Facility based CLEC</b>												
	Recording of Custom Branded OA Announcement					7,000.00						
	Loading of Custom Branded OA Announcement per shelf/NAV per OCN					500.00						
<b>UNEP CLEC</b>												
	Recording of Custom Branded OA Announcement					7,000.00						
	Loading of Custom Branded OA Announcement per shelf/NAV per OCN					500.00						
<b>Unbranding via OLNS for UNEP CLEC</b>												
	Loading of OA per OCN (Regional)					1,200.00						
<b>DIRECTORY ASSISTANCE SERVICES</b>												
<b>DIRECTORY ASSISTANCE ACCESS SERVICE</b>												
	Directory Assistance Access Service Calls, Charge Per Call					0.275						
<b>DIRECTORY ASSISTANCE CALL COMPLETION ACCESS SERVICE (DACC)</b>												
	Directory Assistance Call Completion Access Service (DACC), Per Call Attempt					0.10						
<b>DIRECTORY ASSISTANCE SERVICES</b>												
<b>DIRECTORY ASSISTANCE DATA BASE SERVICE (DADS)</b>												
	Directory Assistance Data Base Service Charge Per Listing					0.04						
	Directory Assistance Data Base Service, per month					150.00						
<b>BRANDING - DIRECTORY ASSISTANCE</b>												
<b>Facility Based CLEC</b>												



UNBUNDLED NETWORK ELEMENTS - Kentucky							Attachment: 2		Exhibit: B				
CATEGORY	RATE ELEMENTS	Interim	Zone	BCS	USOC	RATES (\$)	Svc Order Submitted Elec per LSR	Svc Order Submitted Manually per LSR	Incremental Charge - Manual Svc Order vs. Electronic-1st	Incremental Charge - Manual Svc Order vs. Electronic-Add'l	Incremental Charge - Manual Svc Order vs. Electronic-Disc 1st	Incremental Charge - Manual Svc Order vs. Electronic-Disc Add'l	
													Rec
	Recording and Provisioning of DA Custom Branded Announcement			AMT	CBADA								
	Loading of Custom Branded Announcement per Switch per OCN			AMT	CBADC								
	<b>UNEP CLEC</b>												
	Recording of DA Custom Branded Announcement												
	Loading of DA Custom Branded Announcement per Switch per OCN												
	<b>Unbranding via OLNS for UNEP CLEC</b>												
	Loading of DA per OCN (1 OCN per Order)												
	Loading of DA per Switch per OCN												
	<b>SELECTIVE ROUTING</b>												
	Selective Routing Per Unique Line Class Code Per Request Per Switch				USRCR								
	<b>VIRTUAL COLLOCATION</b>												
	Virtual Collocation-2 Wire Cross Connects (Loop) for Line Splitting			UEPSR, UEPSB	VE1LS	0.309	24.68	23.68	12.14	10.95			7.86
	<b>PHYSICAL COLLOCATION</b>												
	Physical Collocation-2 Wire Cross Connects (Loop) for Line Splitting			UEPSR, UEPSB	PE1LS	0.0333	24.68	23.68	12.14	10.95			7.86
	<b>AIN SELECTIVE CARRIER ROUTING</b>												
	Regional Service Establishment			SRC	SRCEC		193,401.00	193,401.00	9,483.34	9,483.34			7.86
	End Office Establishment			SRC	SRCEO		194.09	194.09	0.85	0.85			7.86
	Line/Port NRC, per end user			SRC	SRCLP		2.06	2.06					7.86
	Query NRC, per query			SRC		0.0037502							
	<b>AIN - BELLSOUTH AIN SMS ACCESS SERVICE</b>												
	AIN SMS Access Service - Service Establishment, Per State, Initial Setup			A1N	CAMSE		43.55	43.55	44.93	44.93			7.86
	AIN SMS Access Service - Port Connection - Dial/Shared Access			A1N	CAMDP		8.64	8.64	10.03	10.03			7.86
	AIN SMS Access Service - Port Connection - ISDN Access			A1N	CAM1P		8.64	8.64	10.03	10.03			7.86
	AIN SMS Access Service - User Identification Codes - Per User ID Code			A1N	CAMAU		38.65	38.65	29.88	29.88			7.86
	AIN SMS Access Service - Security Card, Per User ID Code, Initial or Replacement			A1N	CAMRC		75.08	75.08	12.93	12.93			7.86
	AIN SMS Access Service - Storage, Per Unit (100 Kilobytes)					0.0025							
	AIN SMS Access Service - Session, Per Minute					0.666							
	AIN SMS Access Service - Company Performed Session, Per Minute					0.4608							
	<b>AIN - BELLSOUTH AIN TOOLKIT SERVICE</b>												
	AIN Toolkit Service - Service Establishment Charge, Per State, Initial Setup			CAM	BAPSC		43.55	43.55	44.93	44.93			7.86
	AIN Toolkit Service - Training Session, Per Customer				BAPVX		8,436.93	8,436.93					7.86
	AIN Toolkit Service - Trigger Access Charge, Per Trigger, Per DN, Term, Attempt				BAPTT		8.64	8.64	10.03	10.03			7.86
	AIN Toolkit Service - Trigger Access Charge, Per Trigger, Per DN, Off-Hook Delay				BAPTD		8.64	8.64	10.03	10.03			7.86
	AIN Toolkit Service - Trigger Access Charge, Per Trigger, Per DN, Off-Hook Immediate				BAPTM		8.64	8.64	10.03	10.03			7.86
	AIN Toolkit Service - Trigger Access Charge, Per Trigger, Per DN, 10-Digit PODP				BAPTO		51.01	51.01	18.50	18.50			7.86
	AIN Toolkit Service - Trigger Access Charge, Per Trigger, Per DN, CDP				BAPTC		51.01	51.01	18.50	18.50			7.86
	AIN Toolkit Service - Trigger Access Charge, Per Trigger, Per DN, Feature Code				BAPTF		51.01	51.01	18.50	18.50			7.86
	AIN Toolkit Service - Query Charge, Per Query					0.0549207							
	AIN Toolkit Service - Type 1 Node Charge, Per AIN Toolkit Subscription, Per Node, Per Query					0.0066492							

UNBUNDLED NETWORK ELEMENTS - Kentucky										Attachment: 2		Exhibit: B			
CATEGORY	RATE ELEMENTS	Interim	Zone	BCS	USOC	RATES (\$)				Svc Order Submitted Elec per LSR	Svc Order Submitted Manually per LSR	Incremental Charge - Manual Svc Order vs. Electronic-1st	Incremental Charge - Manual Svc Order vs. Electronic-Add'l	Incremental Charge - Manual Svc Order vs. Electronic-Disc 1st	Incremental Charge - Manual Svc Order vs. Electronic-Disc Add'l
						Rec	Nonrecurring		Nonrecurring Disconnect						
							First	Add'l	First	Add'l	SOMEc	SOMAN	SOMAN	SOMAN	SOMAN
	AIN Toolkit Service - SCP Storage Charge, Per SMS Access Account, Per 100 Kilobytes					0.07									
	AIN Toolkit Service - Monthly report - Per AIN Toolkit Service Subscription		CAM		BAPMS	7.87	8.64	8.64	6.08	6.08		7.86			
	AIN Toolkit Service - Special Study - Per AIN Toolkit Service Subscription		CAM		BAPLS	3.26	9.56	9.56				7.86			
	AIN Toolkit Service - Call Event Report - Per AIN Toolkit Service Subscription		CAM		BAPDS	4.72	8.64	8.64	6.08	6.08		7.86			
	AIN Toolkit Service - Call Event Special Study - Per AIN Toolkit Service Subscription		CAM		BAPES	0.11	9.56	9.56				7.86			
<b>ENHANCED EXTENDED LINK (EELs)</b>															
<b>NOTE: The monthly recurring and non-recurring charges below will apply and the Switch-As-Is Charge will not apply for EELs provisioned as ' Ordinarily Combined' Network Elements.</b>															
<b>NOTE: The monthly recurring and the Switch-As-Is Charge and not the non-recurring charges below will apply for EELs provisioned as ' Currently Combined' Network Elements.</b>															
<b>NOTE: Minimum billing is one month for DS1 and below and three months above DS1 services.</b>															
<b>2-WIRE VOICE GRADE EXTENDED LOOP WITH DEDICATED DS1 INTEROFFICE TRANSPORT (EEL)</b>															
	First 2-Wire VG Loop(SL2) in a DS1 Interofficed Transport Combination - Zone 1		1	UNCVX	UEAL2	12.67	125.22	60.48	59.69	7.84		7.86			
	First 2-Wire VG Grade Loop(SL2) in a DS1 Interofficed Transport Combination - Zone 2		2	UNCVX	UEAL2	17.45	125.22	60.48	59.69	7.84		7.86			
	First 2-Wire VG Grade Loop(SL2) in a DS1 Interofficed Transport Combination - Zone 3		3	UNCVX	UEAL2	33.22	125.22	60.48	59.69	7.84		7.86			
	Interoffice Transport - Dedicated - DS1 combination - Per Mile per month			UNC1X	1L5XX	0.19									
	Interoffice Transport - Dedicated - DS1 combination - Facility Termination per month			UNC1X	U1TF1	79.02	181.24	123.53	56.72	22.32		7.86			
	DS1 Channelization System Per Month			UNC1X	MQ1	113.33	57.26	14.74	1.86	1.67		7.86			
	Voice Grade COCI - DS1 To Ds0 Interface - Per Month			UNCVX	1D1VG	0.62	6.71	4.84				7.86			
	Each Additional 2-Wire VG Loop(SL 2) in the same DS1 Interoffice Transport Combination - Zone 1		1	UNCVX	UEAL2	12.67	125.22	60.48	59.69	7.84		7.86			
	Each Additional 2-Wire VG Loop(SL2) in the same DS1 Interoffice Transport Combination - Zone 2		2	UNCVX	UEAL2	17.45	125.22	60.48	59.69	7.84		7.86			
	Each Additional 2-Wire VG Loop(SL2) in the same DS1 Interoffice Transport Combination - Zone 3		3	UNCVX	UEAL2	33.22	125.22	60.48	59.69	7.84		7.86			
	Voice Grade COCI - DS1 to DS0 Channel System combination - per month			UNCVX	1D1VG	0.62	6.71	4.84				7.86			
	Nonrecurring Currently Combined Network Elements Switch -As-Is Charge			UNC1X	UNCCC		8.98	8.98	11.17	11.17		7.86			
<b>4-WIRE VOICE GRADE EXTENDED LOOP WITH DEDICATED DS1 INTEROFFICE TRANSPORT (EEL)</b>															
	First 4-Wire Analog Voice Grade Loop in a DS1 Interoffice Transport Combination - Zone 1		1	UNCVX	UEAL4	29.26	125.22	60.48	59.69	7.84		7.86			
	First 4-Wire Analog Voice Grade Loop in a DS1 Interoffice Transport Combination - Zone 2		2	UNCVX	UEAL4	34.25	125.22	60.48	59.69	7.84		7.86			
	First 4-Wire Analog Voice Grade Loop in a DS1 Interoffice Transport Combination - Zone 3		3	UNCVX	UEAL4	85.06	125.22	60.48	59.69	7.84		7.86			
	Interoffice Transport - Dedicated - DS1 combination - Per Mile Per Month			UNC1X	1L5XX	0.19									
	Interoffice Transport - Dedicated - DS1 - Facility Termination Per Month			UNC1X	U1TF1	79.02	181.24	123.53	56.72	22.32		7.86			
	Channelization - Channel System DS1 to DS0 combination Per Month			UNC1X	MQ1	113.33	57.26	14.74	1.86	1.67		7.86			
	Voice Grade COCI - DS1 to DS0 Channel System combination - per month			UNCVX	1D1VG	0.62	6.71	4.84				7.86			
	Additional 4-Wire Analog Voice Grade Loop in same DS1 Interoffice Transport Combination - Zone 1		1	UNCVX	UEAL4	29.26	125.22	60.48	59.69	7.84		7.86			
	Additional 4-Wire Analog Voice Grade Loop in same DS1 Interoffice Transport Combination - Zone 2		2	UNCVX	UEAL4	34.25	125.22	60.48	59.69	7.84		7.86			
	Additional 4-Wire Analog Voice Grade Loop in same DS1 Interoffice Transport Combination - Zone 3		3	UNCVX	UEAL4	85.06	125.22	60.48	59.69	7.84		7.86			

UNBUNDLED NETWORK ELEMENTS - Kentucky										Attachment: 2		Exhibit: B				
CATEGORY	RATE ELEMENTS	Interim	Zone	BCS	USOC	RATES (\$)	Svc Order Submitted Elec per LSR	Svc Order Submitted Manually per LSR	Incremental Charge - Manual Svc Order vs. Electronic-1st	Incremental Charge - Manual Svc Order vs. Electronic-Add'l	Incremental Charge - Manual Svc Order vs. Electronic-Disc 1st	Incremental Charge - Manual Svc Order vs. Electronic-Disc Add'l				
													Rec	Nonrecurring		Nonrecurring Disconnect
							First	Add'l	First	Add'l	SOMEc	SOMAN	SOMAN	SOMAN	SOMAN	SOMAN
	Voice Grade COCI - DS1 to DS0 Channel System combination - per month			UNCVX	1D1VG	0.62	6.71	4.84				7.86				
	Nonrecurring Currently Combined Network Elements Switch -As-Is Charge			UNC1X	UNCCC		8.98	8.98	11.17	11.17		7.86				
<b>4-WIRE 56 KBPS EXTENDED DIGITAL LOOP WITH DEDICATED DS1 INTEROFFICE TRANSPORT (EEL)</b>																
	First 4-Wire 56Kbps Digital Grade Loop in a DS1 Interoffice Transport Combination - Zone 1		1	UNCDX	UDL56	27.59	125.22	60.48	59.69	7.84		7.86				
	First 4-wire 56Kbps Digital Grade Loop in a DS1 Interoffice Transport Combination - Zone 2		2	UNCDX	UDL56	32.48	125.22	60.48	59.69	7.84		7.86				
	First 4-Wire 56Kbps Digital Grade Loop in a DS1 Interoffice Transport Combination - Zone 3		3	UNCDX	UDL56	36.37	125.22	60.48	59.69	7.84		7.86				
	Interoffice Transport - Dedicated - DS1 combination - Per Mile Per Month			UNC1X	1L5XX	0.19										
	Interoffice Transport - Dedicated - DS1 - combination Facility Termination Per Month			UNC1X	U1TF1	79.02	181.24	123.53	56.72	22.32		7.86				
	Channelization - Channel System DS1 to DS0 combination Per Month			UNC1X	MQ1	113.33	57.26	14.74	1.86	1.67		7.86				
	OCU-DP COCI (data) - DS1 to DS0 Channel System - per month (2.4-64kbs)			UNCDX	1D1DD	1.32	6.71	4.84				7.86				
	Additional 4-Wire 56Kbps Digital Grade Loop in same DS1 Interoffice Transport Combination - Zone 1		1	UNCDX	UDL56	27.59	125.22	60.48	59.69	7.84		7.86				
	Additional 4-Wire 56Kbps Digital Grade Loop in same DS1 Interoffice Transport Combination - Zone 2		2	UNCDX	UDL56	32.48	125.22	60.48	59.69	7.84		7.86				
	Additional 4-Wire 56Kbps Digital Grade Loop in same DS1 Interoffice Transport Combination - Zone 3		3	UNCDX	UDL56	36.37	125.22	60.48	59.69	7.84		7.86				
	OCU-DP COCI (data) - DS1 to DS0 Channel System - combination per month (2.4-64kbs)			UNCDX	1D1DD	1.32	6.71	4.84				7.86				
	Nonrecurring Currently Combined Network Elements Switch -As-Is Charge			UNC1X	UNCCC		8.98	8.98	11.17	11.17		7.86				
<b>4-WIRE 64 KBPS EXTENDED DIGITAL LOOP WITH DEDICATED DS1 INTEROFFICE TRANSPORT (EEL)</b>																
	First 4-Wire 64Kbps Digital Grade Loop in a DS1 Interoffice Transport Combination - Zone 1		1	UNCDX	UDL64	27.59	125.22	60.48	59.69	7.84		7.86				
	First 4-Wire 64Kbps Digital Grade Loop in a DS1 Interoffice Transport Combination - Zone 2		2	UNCDX	UDL64	32.48	125.22	60.48	59.69	7.84		7.86				
	First 4-Wire 64Kbps Digital Grade Loop in a DS1 Interoffice Transport Combination - Zone 3		3	UNCDX	UDL64	36.37	125.22	60.48	59.69	7.84		7.86				
	Interoffice Transport - Dedicated - DS1 combination - Per Mile Per Month			UNC1X	1L5XX	0.19										
	Interoffice Transport - Dedicated - DS1 combination - Facility Termination Per Month			UNC1X	U1TF1	79.02	181.24	123.53	56.72	22.32		7.86				
	Channelization - Channel System DS1 to DS0 combination Per Month			UNC1X	MQ1	113.33	57.26	14.74	1.86	1.67		7.86				
	OCU-DP COCI (data) - DS1 to DS0 Channel System combination - per month (2.4-64kbs)			UNCDX	1D1DD	1.32	6.71	4.84				7.86				
	Additional 4-Wire 64Kbps Digital Grade Loop in same DS1 Interoffice Transport Combination - Zone 1		1	UNCDX	UDL64	27.59	125.22	60.48	59.69	7.84		7.86				
	Additional 4-Wire 64Kbps Digital Grade Loop in same DS1 Interoffice Transport Combination - Zone 2		2	UNCDX	UDL64	32.48	125.22	60.48	59.69	7.84		7.86				
	Additional 4-Wire 64Kbps Digital Grade Loop in same DS1 Interoffice Transport Combination - Zone 3		3	UNCDX	UDL64	36.37	125.22	60.48	59.69	7.84		7.86				
	OCU-DP COCI (data) - DS1 to DS0 Channel System combination - per month (2.4-64kbs)			UNCDX	1D1DD	1.32	6.71	4.84				7.86				
	Nonrecurring Currently Combined Network Elements Switch -As-Is Charge			UNC1X	UNCCC		8.98	8.98	11.17	11.17		7.86				
<b>4-WIRE DS1 DIGITAL EXTENDED LOOP WITH DEDICATED DS1 INTEROFFICE TRANSPORT (EEL)</b>																
	4-Wire DS1 Digital Loop in Combination with DS1 Interoffice Transport - Zone 1		1	UNC1X	USLXX	86.47	210.70	114.60	63.96	17.97		7.86				
	4-Wire DS1 Digital Loop in Combination with DS1 Interoffice Transport - Zone 2		2	UNC1X	USLXX	114.10	210.70	114.60	63.96	17.97		7.86				

UNBUNDLED NETWORK ELEMENTS - Kentucky									Attachment: 2		Exhibit: B				
CATEGORY	RATE ELEMENTS	Interim	Zone	BCS	USOC	RATES (\$)	Svc Order Submitted Elec per LSR	Svc Order Submitted Manually per LSR	Incremental Charge - Manual Svc Order vs. Electronic-1st	Incremental Charge - Manual Svc Order vs. Electronic-Add'l	Incremental Charge - Manual Svc Order vs. Electronic-Disc 1st	Incremental Charge - Manual Svc Order vs. Electronic-Disc Add'l			
													Rec	Nonrecurring	
										SOMEc	SOMAN	SOMAN	SOMAN	SOMAN	SOMAN
	4-Wire DS1 Digital Loop in Combination with DS1 Interoffice Transport - Zone 3		3	UNC1X	USLXX	297.76		210.70	114.60	63.96	17.97		7.86		
	Interoffice Transport - Dedicated - DS1 combination - Per Mile Per Month			UNC1X	1L5XX	0.19									
	Interoffice Transport - Dedicated - DS1 combination - Facility Termination Per Month			UNC1X	U1TF1	79.02		181.24	123.53	56.72	22.32		7.86		
	Nonrecurring Currently Combined Network Elements Switch -As-Is Charge			UNC1X	UNCCC			8.98	8.98	11.17	11.17		7.86		
	<b>4-WIRE DS1 DIGITAL EXTENDED LOOP WITH DEDICATED DS3 INTEROFFICE TRANSPORT (EEL)</b>														
	First DS1Loop in DS3 Interoffice Transport Combination - Zone 1		1	UNC1X	USLXX	86.47		210.70	114.60	63.96	17.97		7.86		
	First DS1Loop in DS3 Interoffice Transport Combination - Zone 2		2	UNC1X	USLXX	114.10		210.70	114.60	63.96	17.97		7.86		
	First DS1Loop in DS3 Interoffice Transport Combination - Zone 3		3	UNC1X	USLXX	297.76		210.70	114.60	63.96	17.97		7.86		
	Interoffice Transport - Dedicated - DS3 combination - Per Mile Per Month			UNC3X	1L5XX	4.09									
	Interoffice Transport - Dedicated - DS3 - Facility Termination per month			UNC3X	U1TF3	966.89		350.56	141.58	48.00	23.39		7.86		
	DS3 to DS1 Channel System combination per month			UNC3X	MQ3	158.20		115.48	56.53	15.12	5.30		7.86		
	DS3 Interface Unit (DS1 COCI) combination per month			UNC1X	UC1D1	11.80		6.71	4.84				7.86		
	Additional DS1Loop in DS3 Interoffice Transport Combination - Zone 1		1	UNC1X	USLXX	86.47		210.70	114.60	63.96	17.97		7.86		
	Additional DS1Loop in DS3 Interoffice Transport Combination - Zone 2		2	UNC1X	USLXX	114.10		210.70	114.60	63.96	17.97		7.86		
	Additional DS1Loop in DS3 Interoffice Transport Combination - Zone 3		3	UNC1X	USLXX	297.76		210.70	114.60	63.96	17.97		7.86		
	DS3 Interface Unit (DS1 COCI) combination per month			UNC1X	UC1D1	11.80		6.71	4.84				7.86		
	Nonrecurring Currently Combined Network Elements Switch -As-Is Charge			UNC3X	UNCCC			8.98	8.98	11.17	11.17		7.86		
	<b>2-WIRE VOICE GRADE EXTENDED LOOP/ 2 WIRE VOICE GRADE INTEROFFICE TRANSPORT (EEL)</b>														
	2-WireVG Loop used with 2-wire VG Interoffice Transport Combination - Zone 1		1	UNCVX	UEAL2	12.67		125.22	60.48	59.69	7.84		7.86		
	2-WireVG Loop used with 2-wire VG Interoffice Transport Combination - Zone 2		2	UNCVX	UEAL2	17.45		125.22	60.48	59.69	7.84		7.86		
	2-WireVG Loop used with 2-wire VG Interoffice Transport Combination - Zone 3		3	UNCVX	UEAL2	33.22		125.22	60.48	59.69	7.84		7.86		
	Interoffice Transport - Dedicated - 2-wire VG combination - Per Mile Per Month			UNCVX	1L5XX	0.01									
	Interoffice Transport - Dedicated - 2- Wire Voice Grade combination - Facility Termination per month			UNCVX	U1TV2	23.95		98.09	53.67	56.31	22.42		7.86		
	Nonrecurring Currently Combined Network Elements Switch -As-Is Charge			UNCVX	UNCCC			8.98	8.98	11.17	11.17		7.86		
	<b>4-WIRE VOICE GRADE EXTENDED LOOP/ 4 WIRE VOICE GRADE INTEROFFICE TRANSPORT (EEL)</b>														
	4-WireVG Loop used with 4-wire VG Interoffice Transport Combination - Zone 1		1	UNCVX	UEAL4	29.26		125.22	60.48	59.69	7.84		7.86		
	4-WireVG Loop used with 4-wire VG Interoffice Transport Combination - Zone 2		2	UNCVX	UEAL4	34.25		125.22	60.48	59.69	7.84		7.86		
	4-WireVG Loop used with 4-wire VG Interoffice Transport Combination - Zone 3		3	UNCVX	UEAL4	85.06		125.22	60.48	59.69	7.84		7.86		
	Interoffice Transport - Dedicated - 4-wire VG combination - Per Mile Per Month			UNCVX	1L5XX	0.01									
	Interoffice Transport - Dedicated - 4- Wire Voice Grade combination - Facility Termination per month			UNCVX	U1TV4	21.28		98.09	53.67	56.31	22.42		7.86		
	Nonrecurring Currently Combined Network Elements Switch -As-Is Charge			UNCVX	UNCCC			8.98	8.98	11.17	11.17		7.86		
	<b>DS3 DIGITAL EXTENDED LOOP WITH DEDICATED DS3 INTEROFFICE TRANSPORT (EEL)</b>														
	High Capacity Unbundled Local Loop - DS3 combination - Per Mile per month			UNC3X	1L5ND	9.25									

**UNBUNDLED NETWORK ELEMENTS - Kentucky**

UNBUNDLED NETWORK ELEMENTS - Kentucky										Attachment: 2		Exhibit: B				
CATEGORY	RATE ELEMENTS	Interim	Zone	BCS	USOC	RATES (\$)	Svc Order Submitted Elec per LSR	Svc Order Submitted Manually per LSR	Incremental Charge - Manual Svc Order vs. Electronic-1st	Incremental Charge - Manual Svc Order vs. Electronic-Add'l	Incremental Charge - Manual Svc Order vs. Electronic-Disc 1st	Incremental Charge - Manual Svc Order vs. Electronic-Disc Add'l				
													Rec	Nonrecurring		Nonrecurring Disconnect
										SOMEc	SOMAN	SOMAN	SOMAN	SOMAN	SOMAN	
	High Capacity Unbundled Local Loop - DS3 combination - Facility Termination per month			UNC3X	UE3PX	308.31		237.36	147.69	83.43	32.67		7.86			
	Interoffice Transport - Dedicated - DS3 - Per Mile per month			UNC3X	1L5XX	4.09										
	Interoffice Transport - Dedicated - DS3 combination - Facility Termination per month			UNC3X	U1TF3	966.89		350.56	141.58	48.00	23.39		7.86			
	Nonrecurring Currently Combined Network Elements Switch -As-Is Charge			UNC3X	UNCCC			8.98	8.98	11.17	11.17		7.86			
<b>STS1 DIGITAL EXTENDED LOOP WITH DEDICATED STS1 INTEROFFICE TRANSPORT (EEL)</b>																
	High Capacity Unbundled Local Loop - STS1 combination - Per Mile per month			UNCSX	1L5ND	9.25										
	High Capacity Unbundled Local Loop - STS1 combination - Facility Termination per month			UNCSX	UDLS1	320.51		237.36	147.69	83.43	32.67		7.86			
	Interoffice Transport - Dedicated - STS1 combination - Per Mile per month			UNCSX	1L5XX	4.09										
	Interoffice Transport - Dedicated - STS1 combination - Facility Termination per month			UNCSX	U1TFS	945.79		350.56	141.58	48.00	23.39		7.86			
	Nonrecurring Currently Combined Network Elements Switch -As-Is Charge			UNCSX	UNCCC			8.98	8.98	11.17	11.17		7.86			
<b>2-WIRE ISDN EXTENDED LOOP WITH DS1 INTEROFFICE TRANSPORT (EEL)</b>																
	First 2-Wire ISDN Loop in a DS1 Interoffice Combination Transport - Zone 1		1	UNCNX	U1L2X	18.44		125.22	60.48	59.69	7.84		7.86			
	First 2-Wire ISDN Loop in a DS1 Interoffice Combination Transport - Zone 2		2	UNCNX	U1L2X	25.08		125.22	60.48	59.69	7.84		7.86			
	First 2-Wire ISDN Loop in a DS1 Interoffice Combination Transport - Zone 3		3	UNCNX	U1L2X	42.87		125.22	60.48	59.69	7.84		7.86			
	Interoffice Transport - Dedicated - DS1 combination - Per Mile			UNC1X	1L5XX	0.19										
	Interoffice Transport - Dedicated - DS1 combination - Facility Termination per month			UNC1X	U1TF1	79.02		181.24	123.53	56.72	22.32		7.86			
	Channelization - Channel System DS1 to DS0 combination - per month			UNC1X	MQ1	113.33		57.26	14.74	1.86	1.67		7.86			
	2-wire ISDN COCI (BRITE) - DS1 to DS0 Channel System combination - per month			UNCNX	UC1CA	2.84		6.71	4.84				7.86			
	Additional 2-wire ISDN Loop in same DS1 Interoffice Transport Combination - Zone 1		1	UNCNX	U1L2X	18.44		125.22	60.48	59.69	7.84		7.86			
	Additional 2-wire ISDN Loop in same DS1 Interoffice Transport Combination - Zone 2		2	UNCNX	U1L2X	25.08		125.22	60.48	59.69	7.84		7.86			
	Additional 2-wire ISDN Loop in same DS1 Interoffice Transport Combination - Zone 3		3	UNCNX	U1L2X	42.87		125.22	60.48	59.69	7.84		7.86			
	2-wire ISDN COCI (BRITE) - DS1 to DS0 Channel System combination - per month			UNCNX	UC1CA	2.84		6.71	4.84				7.86			
	Nonrecurring Currently Combined Network Elements Switch -As-Is Charge			UNC1X	UNCCC			8.98	8.98	11.17	11.17		7.86			
<b>4-WIRE DS1 DIGITAL EXTENDED LOOP WITH DEDICATED STS-1 INTEROFFICE TRANSPORT (EEL)</b>																
	First DS1 Loop in STS1 Interoffice Transport Combination - Zone 1		1	UNC1X	USLXX	86.47		210.70	114.60	63.96	17.97		7.86			
	First DS1 Loop in STS1 Interoffice Transport Combination - Zone 2		2	UNC1X	USLXX	114.10		210.70	114.60	63.96	17.97		7.86			
	First DS1 Loop in STS1 Interoffice Transport Combination - Zone 3		3	UNC1X	USLXX	297.76		210.70	114.60	63.96	17.97		7.86			
	Interoffice Transport - Dedicated - STS1 combination - Per Mile Per Month			UNCSX	1L5XX	4.09										
	Interoffice Transport - Dedicated - STS1 combination - Facility Termination			UNCSX	U1TFS	945.79		350.56	141.58	48.00	23.39		7.86			
	STS1 to DS1 Channel System combination per month			UNCSX	MQ3	158.20		115.48	56.53	15.12	5.30		7.86			
	DS3 Interface Unit (DS1 COCI) combination per month			UNC1X	UC1D1	11.80		6.71	4.84				7.86			
	Additional DS1 Loop in STS1 Interoffice Transport Combination - Zone 1		1	UNC1X	USLXX	86.47		210.70	114.60	63.96	17.97		7.86			
	Additional DS1 Loop in STS1 Interoffice Transport Combination - Zone 2		2	UNC1X	USLXX	114.10		210.70	114.60	63.96	17.97		7.86			

UNBUNDLED NETWORK ELEMENTS - Kentucky							Attachment: 2		Exhibit: B						
CATEGORY	RATE ELEMENTS	Interim	Zone	BCS	USOC	RATES (\$)	Svc Order Submitted Elec per LSR	Svc Order Submitted Manually per LSR	Incremental Charge - Manual Svc Order vs. Electronic-1st	Incremental Charge - Manual Svc Order vs. Electronic-Add'l	Incremental Charge - Manual Svc Order vs. Electronic-Disc 1st	Incremental Charge - Manual Svc Order vs. Electronic-Disc Add'l			
							Rec	Nonrecurring		Nonrecurring Disconnect		OSS Rates(\$)			
							First	Add'l	First	Add'l	SOMEc	SOMAN	SOMAN	SOMAN	SOMAN
	Additional DS1Loop in STS1 Interoffice Transport Combination - Zone 3		3	UNC1X	USLXX	297.76	210.70	114.60	63.96	17.97		7.86			
	DS3 Interface Unit (DS1 COCI) combination per month			UNC1X	UC1D1	11.80	6.71	4.84				7.86			
	Nonrecurring Currently Combined Network Elements Switch -As-Is Charge			UNCSX	UNCCC		8.98	8.98	11.17	11.17		7.86			
<b>4-WIRE 56 KBPS DIGITAL EXTENDED LOOP WITH 56 KBPS INTEROFFICE TRANSPORT (EEL)</b>															
	4-wire 56 kbps Loop/4-wire 56 kbps Interoffice Transport Combination - Zone 1		1	UNCDX	UDL56	27.59	125.22	60.48	59.69	7.84		7.86			
	4-wire 56 kbps Loop/4-wire 56 kbps Interoffice Transport Combination - Zone 2		2	UNCDX	UDL56	32.48	125.22	60.48	59.69	7.84		7.86			
	4-wire 56 kbps Loop/4-wire 56 kbps Interoffice Transport Combination - Zone 3		3	UNCDX	UDL56	36.37	125.22	60.48	59.69	7.84		7.86			
	Interoffice Transport - Dedicated - 4-wire 56 kbps combination - Per Mile			UNCDX	1L5XX	0.01									
	Interoffice Transport - Dedicated - 4-wire 56 kbps combination - Facility Termination			UNCDX	U1TD5	17.25	98.09	53.67	56.31	22.42		7.86			
	Nonrecurring Currently Combined Network Elements Switch -As-Is Charge			UNCDX	UNCCC		8.98	8.98	11.17	11.17		7.86			
<b>4-WIRE 64 KBPS DIGITAL EXTENDED LOOP WITH 64 KBPS INTEROFFICE TRANSPORT (EEL)</b>															
	4-wire 64 kbps Loop/4-wire 64 kbps Interoffice Transport Combination - Zone 1		1	UNCDX	UDL64	27.59	125.22	60.48	59.69	7.84		7.86			
	4-wire 64 kbps Loop/4-wire 64 kbps Interoffice Transport Combination - Zone 2		2	UNCDX	UDL64	32.48	125.22	60.48	59.69	7.84		7.86			
	4-wire 64 kbps Loop/4-wire 64 kbps Interoffice Transport Combination - Zone 3		3	UNCDX	UDL64	36.37	125.22	60.48	59.69	7.84		7.86			
	Interoffice Transport - Dedicated - 4-wire 64 kbps combination - Per Mile			UNCDX	1L5XX	0.01									
	Interoffice Transport - Dedicated - 4-wire 64 kbps combination - Facility Termination			UNCDX	U1TD6	17.25	98.09	53.67	56.31	22.42		7.86			
	Nonrecurring Currently Combined Network Elements Switch -As-Is Charge			UNCDX	UNCCC		8.98	8.98	11.17	11.17		7.86			
<b>ADDITIONAL NETWORK ELEMENTS</b>															
<b>When used as a part of a currently combined facility, the non-recurring charges do not apply, but a Switch As Is charge does apply.</b>															
<b>When used as ordinarily combined network elements in All States, the non-recurring charges apply and the Switch As Is Charge does not.</b>															
<b>Nonrecurring Currently Combined Network Elements "Switch As Is" Charge (One applies to each combination)</b>															
	Nonrecurring Currently Combined Network Elements Switch -As-Is Charge - 2 wire/4-Wire VG			UNCVX	UNCCC		8.98	8.98	11.17	11.17		7.86			
	Nonrecurring Currently Combined Network Elements Switch -As-Is Charge - 56/64 kbps			UNCDX	UNCCC		8.98	8.98	11.17	11.17		7.86			
	Nonrecurring Currently Combined Network Elements Switch -As-Is Charge - DS1			UNC1X	UNCCC		8.98	8.98	11.17	11.17		7.86			
	Nonrecurring Currently Combined Network Elements Switch -As-Is Charge - DS3			UNC3X	UNCCC		8.98	8.98	11.17	11.17		7.86			
	Nonrecurring Currently Combined Network Elements Switch -As-Is Charge - STS1			UNCSX	UNCCC		8.98	8.98	11.17	11.17		7.86			
<b>NOTE: Local Channel - Dedicated Transport - minimum billing period - Below DS3=one month, DS3 and above=four months</b>															
	Local Channel - Dedicated - 2-Wire Voice Grade			UNCVX	ULDV2	18.57	265.78	46.96	46.79	4.98		7.86			
	Local Channel - Dedicated - 4-Wire Voice Grade			UNCVX	ULDV4	19.86	266.48	47.65	47.54	5.73		7.86			
	Local Channel - Dedicated - DS1 per month Zone 1		1	UNC1X	ULDF1	40.46	209.60	176.51	30.21	21.07		7.86			
	Local Channel - Dedicated - DS1 Per Month Zone 2		2	UNC1X	ULDF1	43.39	209.60	176.51	30.21	21.07		7.86			
	Local Channel - Dedicated - DS1- Per Month Zone 3		3	UNC1X	ULDF1	164.50	209.60	176.51	30.21	21.07		7.86			
	Local Channel - Dedicated - DS3 - Per Mile per month			UNC3X	1L5NC	8.74									
	Local Channel - Dedicated - DS3 - Facility Termination			UNC3X	ULDF3	576.05	551.38	338.08	173.00	120.42		7.86			
	Local Channel - Dedicated - STS-1 - Per Mile per month			UNCSX	1L5NC	8.74									
	Local Channel - Dedicated - STS-1 - Facility Termination			UNCSX	ULDFS	543.24	551.38	338.08	173.00	120.42		7.86			
	Clear Channel Capability (SF/ESF) Option - Subsequent Activity - per DS1		i	ULDD1, U1TD1, UNC1X, USL	NRCCC	65.04						7.86			
	C-bit Parity Option - Subsequent Activity - per DS3		i	U1TD3, ULDD3, UE3, UNC3X	NRCC3	50.04						7.86			

UNBUNDLED NETWORK ELEMENTS - Kentucky										Attachment: 2		Exhibit: B																							
CATEGORY	RATE ELEMENTS	Interim	Zone	BCS	USOC	RATES (\$)	Svc Order Submitted Elec per LSR	Svc Order Submitted Manually per LSR	Incremental Charge - Manual Svc Order vs. Electronic-1st	Incremental Charge - Manual Svc Order vs. Electronic-Add'l	Incremental Charge - Manual Svc Order vs. Electronic-Disc 1st	Incremental Charge - Manual Svc Order vs. Electronic-Disc Add'l	OSS Rates(\$)																						
													Rec	Nonrecurring First	Nonrecurring Add'l	Nonrecurring Disconnect First	Nonrecurring Disconnect Add'l	SOMEc	SOMAN	SOMAN	SOMAN	SOMAN	SOMAN												
<b>MULTIPLEXERS</b>																																			
NOTE: minimum billing period is one month for DS1 to DS0 Channel System and interfaces																																			
NOTE: minimum billing period is three months for DS3 to DS1 Channel System and interfaces																																			
	DS1 to DS0 Channel System (with the higher-level connected to a collocation in the same SWC) per month			UXTD1	MQ1	113.33	101.40	71.60	13.79	13.04			7.86																						
	DS1 to DS0 Channel System (used to channelize a DS1 Local Channel) per month			ULDD1	MQ1	113.33	101.40	71.60	13.79	13.04			7.86																						
	DS1 to DS0 Channel System (used to channelize a DS1 Interoffice Channel) per month			U1TD1	MQ1	113.33	101.40	71.60	13.79	13.04			7.86																						
	OCU-DP COCI (data) - DS1 to DS0 Channel System - per month (2.4-64kbs) used for a Local Loop			UDL	1D1DD	1.32	10.07	7.08					7.86																						
	OCU-DP COCI (data) - DS1 to DS0 Channel System - per month (2.4-64kbs) used for connection to a channelized DS1 Local Channel in the same SWC as collocation			U1TUD	1D1DD	1.32	10.07	7.08					7.86																						
	2-wire ISDN COCI (BRITE) - DS1 to DS0 Channel System - per month for a Local Loop			UDN	UC1CA	2.84	10.07	7.08					7.86																						
	2-wire ISDN COCI (BRITE) - DS1 to DS0 Channel System - per month used for connection to a channelized DS1 Local Channel in the same SWC as collocation			U1TUB	UC1CA	2.84	10.07	7.08					7.86																						
	Voice Grade COCI - DS1 to DS0 Channel System - per month used for a Local Loop			UEA	1D1VG	0.6228	10.07	7.08					7.86																						
	Voice Grade COCI - DS1 to DS0 Channel System - per month used for connection to a channelized DS1 Local Channel in the same SWC as collocation			U1TUC	1D1VG	0.6228	10.07	7.08					7.86																						
	DS3 to DS1 Channel System (with the higher level connected to a collocation in the same SWC) per month			UXTD3	MQ3	158.20	199.23	118.62	50.16	48.59			7.86																						
	DS3 to DS1 Channel System (used to channelize a DS3 Local Channel) per month			ULDD3	MQ3	158.20	199.23	118.62	50.16	48.59			7.86																						
	DS3 to DS1 Channel System (used to channelize a DS3 Interoffice Channel) per month			U1TD3	MQ3	158.20	199.23	118.62	50.16	48.59			7.86																						
	STS-1 to DS1 Channel System (with the higher level connected to a collocation in the same SWC) per month			UXTS1	MQ3	158.20	199.23	118.62	50.16	48.59			7.86																						
	STS-1 to DS1 Channel System (used to channelize a STS-1 Local Channel) per month			ULDS1	MQ3	158.20	199.23	118.62	50.16	48.59			7.86																						
	STS-1 to DS1 Channel System (used to channelize a STS-1 Interoffice Channel) per month			U1TS1	MQ3	158.20	199.23	118.62	50.16	48.59			7.86																						
	DS1 COCI used with Loop per month			USL	UC1D1	11.80	10.07	7.08					7.86																						
	DS1 COCI (used for connection to a channelized DS1 Local Channel in the same SWC as collocation) per month			U1TUA	UC1D1	11.80	10.07	7.08					7.86																						
	DS1 COCI used with Interoffice Channel per month			U1TD1	UC1D1	11.80	10.07	7.08					7.86																						
<b>Sub-Loop Feeder</b>																																			
	Unbundled Sub-Loop Feeder Loop, 4-Wire DS1 - Zone 1		1	UNC1X	USBFG	62.57	125.43	73.68	81.82	21.56																									
	Unbundled Sub-Loop Feeder Loop, 4-Wire DS1 - Zone 2		2	UNC1X	USBFG	87.71	125.43	73.68	81.82	21.56																									
	Unbundled Sub-Loop Feeder Loop, 4-Wire DS1 - Zone 3		3	UNC1X	USBFG	273.33	125.43	73.68	81.82	21.56																									
<b>UNBUNDLED LOCAL EXCHANGE SWITCHING(PORTS)</b>																																			
<b>Exchange Ports</b>																																			
NOTE: Although the Port Rate includes all available features in GA, KY, LA & TN, the desired features will need to be ordered using retail USOCs																																			
<b>2-WIRE VOICE GRADE LINE PORT RATES (RES)</b>																																			
	Exchange Ports - 2-Wire Analog Line Port- Res.			UEPSR	UEPRL	1.49	3.74	3.63	2.23	2.13			7.86																						
	Exchange Ports - 2-Wire Analog Line Port with Caller ID - Res.			UEPSR	UEPRC	1.49	3.74	3.63	2.23	2.13			7.86																						
	Exchange Ports - 2-Wire Analog Line Port outgoing only - Res.			UEPSR	UEPRO	1.49	3.74	3.63	2.23	2.13			7.86																						
	Exchange Ports - 2-Wire VG unbundled KY extended local dialing parity Port with Caller ID - Res.			UEPSR	UEPRM	1.49	3.74	3.63	2.23	2.13			7.86																						
	Exchange Ports - 2-Wire VG unbundled res, low usage line port with Caller ID (LUM)			UEPSR	UEPAP	1.49	3.74	3.63	2.23	2.13			7.86																						
	Exchange Ports - 2-Wire Voice Kentucky Residence Dialing Plan without Caller ID			UEPSR	UEPWE	1.49	3.74	3.63	2.23	2.13			7.86																						

UNBUNDLED NETWORK ELEMENTS - Kentucky										Attachment: 2		Exhibit: B				
CATEGORY	RATE ELEMENTS	Interim	Zone	BCS	USOC	RATES (\$)					Svc Order Submitted Elec per LSR	Svc Order Submitted Manually per LSR	Incremental Charge - Manual Svc Order vs. Electronic-1st	Incremental Charge - Manual Svc Order vs. Electronic-Add'l	Incremental Charge - Manual Svc Order vs. Electronic-Disc 1st	Incremental Charge - Manual Svc Order vs. Electronic-Disc Add'l
						Rec	Nonrecurring		Nonrecurring Disconnect							
							First	Add'l	First	Add'l	SOMEc	SOMAN	SOMAN	SOMAN	SOMAN	SOMAN
	2-Wire voice unbundled Low Usage Line Port without Caller ID Capability			UEPSR	UEPRT	1.49	3.74	3.63	2.23	2.13		7.86				
	Subsequent Activity			UEPSR	USASC	0.00	0.00	0.00				7.86				
	<b>FEATURES</b>															
	All Available Vertical Features			UEPSR	UEPVF	0.00	0.00	0.00				7.86				
	<b>2-WIRE VOICE GRADE LINE PORT RATES (BUS)</b>															
	Exchange Ports - 2-Wire Analog Line Port without Caller ID - Bus			UEPSB	UEPBL	1.49	3.74	3.63	2.23	2.13		7.86				
	Exchange Ports - 2-Wire VG unbundled Line Port with unbundled port with Caller+E484 ID - Bus.			UEPSB	UEPBC	1.49	3.74	3.63	2.23	2.13		7.86				
	Exchange Ports - 2-Wire Analog Line Port outgoing only - Bus.			UEPSB	UEPBO	1.49	3.74	3.63	2.23	2.13		7.86				
	Exchange Ports - 2-Wire VG unbundled KY extended local dialing parity Port with Caller ID - Bus.			UEPSB	UEPBM	1.49	3.74	3.63	2.23	2.13		7.86				
	Exchange Ports - 2-Wire VG unbundled incoming only port with Caller ID - Bus			UEPSB	UEPB1	1.49	3.74	3.63	2.23	2.13		7.86				
	Exchange Ports - 2-Wire Voice Kentucky Business Dialing Plan without Caller ID			UEPSB	UEPWF	1.49	3.74	3.63	2.23	2.13		7.86				
	2-Wire voice unbundled Incoming Only Port without Caller ID Capability			UEPSB	UEPBE	1.49	3.74	3.63	2.23	2.13		7.86				
	Subsequent Activity			UEPSB	USASC	0.00	0.00	0.00				7.86				
	<b>FEATURES</b>															
	All Available Vertical Features			UEPSB	UEPVF	0.00	0.00	0.00				7.86				
	<b>EXCHANGE PORT RATES (DID &amp; PBX)</b>															
	2-Wire VG Unbundled 2-Way PBX Trunk - Res			UEPSE	UEPRD	1.49	39.05	18.17	15.38	0.89		7.86				
	2-Wire VG Line Side Unbundled 2-Way PBX Trunk - Bus			UEPSP	UEPPC	1.49	39.05	18.17	15.38	0.89		7.86				
	2-Wire VG Line Side Unbundled Outward PBX Trunk - Bus			UEPSP	UEPPO	1.49	39.05	18.17	15.38	0.89		7.86				
	2-Wire VG Line Side Unbundled Incoming PBX Trunk - Bus			UEPSP	UEPP1	1.49	39.05	18.17	15.38	0.89		7.86				
	2-Wire Analog Long Distance Terminal PBX Trunk - Bus			UEPSP	UEPLD	1.49	39.05	18.17	15.38	0.89		7.86				
	2-Wire Voice Unbundled PBX LD Terminal Ports			UEPSP	UEPLD	1.49	39.05	18.17	15.38	0.89		7.86				
	2-Wire Vce Unbundled 2-Way PBX Usage Port			UEPSP	UEPXA	1.49	39.05	18.17	15.38	0.89		7.86				
	2-Wire Voice Unbundled PBX Toll Terminal Hotel Ports			UEPSP	UEPXB	1.49	39.05	18.17	15.38	0.89		7.86				
	2-Wire Voice Unbundled PBX LD DDD Terminals Port			UEPSP	UEPXC	1.49	39.05	18.17	15.38	0.89		7.86				
	2-Wire Voice Unbundled PBX LD Terminal Switchboard Port			UEPSP	UEPXD	1.49	39.05	18.17	15.38	0.89		7.86				
	2-Wire Voice Unbundled PBX LD Terminal Switchboard IDD Capable Port			UEPSP	UEPXE	1.49	39.05	18.17	15.38	0.89		7.86				
	2-Wire Voice Unbundled 2-Way PBX Kentucky Room Area Calling Port Without LUD			UEPSP	UEPXF	1.49	39.05	18.17	15.38	0.89		7.86				
	2-Wire Voice Unbundled PBX Kentucky LUD Area Calling Port			UEPSP	UEPXG	1.49	39.05	18.17	15.38	0.89		7.86				
	2-Wire Voice Unbundled PBX Kentucky Premium Calling Port			UEPSP	UEPXH	1.49	39.05	18.17	15.38	0.89		7.86				
	2-Wire Voice Unbundled 2-Way PBX Kentucky Area Calling Port Without LUD			UEPSP	UEPXJ	1.49	39.05	18.17	15.38	0.89		7.86				
	2-Wire Voice Unbundled 2-Way PBX Hotel/Hospital Economy Administrative Calling Port			UEPSP	UEPXL	1.49	39.05	18.17	15.38	0.89		7.86				
	2-Wire Voice Unbundled 2-Way PBX Hotel/Hospital Economy Room Calling Port			UEPSP	UEPXM	1.49	39.05	18.17	15.38	0.89		7.86				
	2-Wire Voice Unbundled 1-Way Outgoing PBX Hotel/Hospital Discount Room Calling Port			UEPSP	UEPXO	1.49	39.05	18.17	15.38	0.89		7.86				
	2-Wire Voice Unbundled 1-Way Outgoing PBX Measured Port			UEPSP	UEPXS	1.49	39.05	18.17	15.38	0.89		7.86				
	Subsequent Activity			UEPSP	USASC	0.00	0.00	0.00				7.86				
	<b>FEATURES</b>															
	All Available Vertical Features			UEPSP	UEPSE	0.00	0.00	0.00				7.86				
	<b>EXCHANGE PORT RATES (COIN)</b>															
	Exchange Ports - Coin Port					1.49	3.74	3.63	2.23	2.13		7.86				
	<b>Local Switching Features offered with Port</b>															
	<b>NOTE: Transmission/usage charges associated with POTS circuit switched usage will also apply to circuit switched voice and/or circuit switched data transmission by B-Channels associated with 2-wire ISDN ports.</b>															
	<b>NOTE: Access to B Channel or D Channel Packet capabilities will be available only through BFR/New Business Request Process. Rates for the packet capabilities will be determined via the Bona Fide Request/New Business Request Process.</b>															
	Exchange port - 4-wire ISDN trunk port -all available features included			UEPEX		101.60	188.36	95.15	61.92	22.67		7.86				



UNBUNDLED NETWORK ELEMENTS - Kentucky										Attachment: 2		Exhibit: B	
CATEGORY	RATE ELEMENTS	Interim	Zone	BCS	USOC	RATES (\$)	Svc Order Submitted Elec per LSR	Svc Order Submitted Manually per LSR	Incremental Charge - Manual Svc Order vs. Electronic-1st	Incremental Charge - Manual Svc Order vs. Electronic-Add'l	Incremental Charge - Manual Svc Order vs. Electronic-Disc 1st	Incremental Charge - Manual Svc Order vs. Electronic-Disc Add'l	
													Rec
UNBUNDLED LOCAL EXCHANGE SWITCHING(PORTS)													
EXCHANGE PORT RATES													
	Exchange Ports - 2-Wire DID Port			UEPEX	UEPP2	10.51	92.18	15.82	52.16	5.30		7.86	
	Exchange Ports - DDITS Port - 4-Wire DS1 Port with DID capability			UEPDD	UEPDD	74.77	164.86	77.74	60.69	3.86		7.86	
	Exchange Ports - 2-Wire ISDN Port (See Notes below.)			UEPTX UEPSX	U1PMA	13.46	60.60	50.67	32.83	14.17		7.86	
	All Features Offered			UEPTX UEPSX	UEPVF	0.00	0.00	0.00					
NOTE: Transmission/usage charges associated with POTS circuit switched usage will also apply to circuit switched voice and/or circuit switched data transmission by B-Channels associated with 2-wire ISDN ports.													
NOTE: Access to B Channel or D Channel Packet capabilities will be available only through BFR/New Business Request Process. Rates for the packet capabilities will be determined via the Bona Fide Request/New Business Request Process.													
	Exchange Ports - 2-Wire ISDN Port -- Channel Profiles			UEPTX UEPSX	U1UMA	0.00	0.00	0.00					
	Exchange Ports - 4-Wire ISDN DS1 Port			UEPEX	UEPEX	101.60	188.36	95.15	61.92	22.67		7.86	
UNBUNDLED PORT with REMOTE CALL FORWARDING CAPABILITY													
UNBUNDLED REMOTE CALL FORWARDING SERVICE - RESIDENCE													
	Unbundled Remote Call Forwarding Service, Area Calling, Res			UEPVR	UERAC	1.49	3.74	3.63				7.86	
	Unbundled Remote Call Forwarding Service, Local Calling - Res			UEPVR	UERLC	1.49	3.74	3.63				7.86	
	Unbundled Remote Call Forwarding Service, InterLATA - Res			UEPVR	UERTE	1.49	3.74	3.63				7.86	
	Unbundled Remote Call Forwarding Service, IntraLATA - Res			UEPVR	UERTR	1.49	3.74	3.63				7.86	
Non-Recurring													
	Unbundled Remote Call Forwarding Service - Conversion - Switch-as-is			UEPVR	USAC2		0.10	0.10				7.86	
	Unbundled Remote Call Forwarding Service - Conversion with allowed change (PIC and LPIC)			UEPVR	USACC		0.10	0.10					
UNBUNDLED REMOTE CALL FORWARDING - Bus													
	Unbundled Remote Call Forwarding Service, Area Calling - Bus			UEPVB	UERAC	1.49	3.74	3.63				7.86	
	Unbundled Remote Call Forwarding Service, Local Calling - Bus			UEPVB	UERLC	1.49	3.74	3.63				7.86	
	Unbundled Remote Call Forwarding Service, InterLATA - Bus			UEPVB	UERTE	1.49	3.74	3.63				7.86	
	Unbundled Remote Call Forwarding Service, IntraLATA - Bus			UEPVB	UERTR	1.49	3.74	3.63				7.86	
	Unbundled Remote Call Forwarding Service Expanded and Exception Local Calling			UEPVB	UERVJ	1.49	3.74	3.63				7.86	
Non-Recurring													
	Unbundled Remote Call Forwarding Service - Conversion - Switch-as-is			UEPVB	USAC2		0.10	0.10				7.86	
	Unbundled Remote Call Forwarding Service - Conversion with allowed change (PIC and LPIC)			UEPVB	USACC		0.10	0.10					
UNBUNDLED LOCAL SWITCHING, PORT USAGE													
End Office Switching (Port Usage)													
	End Office Switching Function, Per MOU					0.0011971							
	End Office Trunk Port - Shared, Per MOU					0.0002112							
Tandem Switching (Port Usage) (Local or Access Tandem)													
	Tandem Switching Function Per MOU					0.000194							
	Tandem Trunk Port - Shared, Per MOU					0.0002416							
Common Transport													
	Common Transport - Per Mile, Per MOU					0.000003							
	Common Transport - Facilities Termination Per MOU					0.0007466							
UNBUNDLED PORT/LOOP COMBINATIONS - COST BASED RATES													
Cost Based Rates are applied where BellSouth is required by FCC and/or State Commission rule to provide Unbundled Local Switching or Switch Ports.													
Features shall apply to the Unbundled Port/Loop Combination - Cost Based Rate section in the same manner as they are applied to the Stand-Alone Unbundled Port section of this Rate Exhibit.													
End Office and Tandem Switching Usage and Common Transport Usage rates in the Port section of this rate exhibit shall apply to all combinations of loop/port network elements except for UNE Coin Port/Loop Combinations.													
The first and additional Port nonrecurring charges apply to Not Currently Combined Combos. For Currently Combined Combos the nonrecurring charges shall be those identified in the Nonrecurring - Currently Combined sections.													
2-WIRE VOICE GRADE LOOP WITH 2-WIRE LINE PORT (RES)													
UNE Port/Loop Combination Rates													
	2-Wire VG Loop/Port Combo - Zone 1		1			10.79							
	2-Wire VG Loop/Port Combo - Zone 2		2			15.52							
	2-Wire VG Loop/Port Combo - Zone 3		3			31.74							
UNE Loop Rates													
	2-Wire Voice Grade Loop (SL1) - Zone 1		1	UEPRX	UEPLX	9.64							

UNBUNDLED NETWORK ELEMENTS - Kentucky										Attachment: 2		Exhibit: B			
CATEGORY	RATE ELEMENTS	Interim	Zone	BCS	USOC	RATES (\$)	Svc Order Submitted Elec per LSR	Svc Order Submitted Manually per LSR	Incremental Charge - Manual Svc Order vs. Electronic-1st	Incremental Charge - Manual Svc Order vs. Electronic-Add'l	Incremental Charge - Manual Svc Order vs. Electronic-Disc 1st	Incremental Charge - Manual Svc Order vs. Electronic-Disc Add'l			
													Rec	Nonrecurring	
										SOMEc	SOMAN	SOMAN	SOMAN	SOMAN	SOMAN
	2-Wire Voice Grade Loop (SL1) - Zone 2		2	UEPRX	UEPLX	14.37									
	2-Wire Voice Grade Loop (SL1) - Zone 3		3	UEPRX	UEPLX	30.59									
	<b>2-Wire Voice Grade Line Port Rates (Res)</b>														
	2-Wire voice unbundled port - residence			UEPRX	UEPRL	1.15	21.29	15.49	2.85	2.67		7.86			
	2-Wire voice unbundled port with Caller ID - res			UEPRX	UEPRC	1.15	21.29	15.49	2.85	2.67		7.86			
	2-Wire voice unbundled port outgoing only - res			UEPRX	UEPRO	1.15	21.29	15.49	2.85	2.67		7.86			
	2-Wire voice Grade unbundled Kentucky extended local dialing parity port with Caller ID - res			UEPRX	UEPRM	1.15	21.29	15.49	2.85	2.67		7.86			
	2-Wire voice unbundles res, low usage line port with Caller ID (LUM)			UEPRX	UEPAP	1.15	21.29	15.49	2.85	2.67		7.86			
	2-Wire Voice Unbundled Kentucky Residence Dialing Plan without Caller ID			UEPRX	UEPWE	1.15	21.29	15.49	2.85	2.67		7.86			
	2-Wire voice unbundled Low Usage Line Port without Caller ID Capability			UEPRX	UEPRT	1.15	21.29	15.49	2.85	2.67		7.86			
	<b>FEATURES</b>														
	All Features Offered			UEPRX	UEPVF	0.00	0.00	0.00				7.86			
	<b>LOCAL NUMBER PORTABILITY</b>														
	Local Number Portability (1 per port)			UEPRX	LNPCX	0.35									
	<b>NONRECURRING CHARGES (NRCs) - CURRENTLY COMBINED</b>														
	2-Wire Voice Grade Loop / Line Port Combination - Conversion - Switch-as-is			UEPRX	USAC2		0.10	0.10				7.86			
	2-Wire Voice Grade Loop / Line Port Combination - Conversion - Switch with change			UEPRX	USACC		0.10	0.10				7.86			
	<b>ADDITIONAL NRCs</b>														
	2-Wire Voice Grade Loop/Line Port Combination - Subsequent Activity			UEPRX	USAS2	0.00	0.00	0.00				7.86			
	<b>2-WIRE VOICE GRADE LOOP WITH 2-WIRE LINE PORT (BUS)</b>														
	<b>UNE Port/Loop Combination Rates</b>														
	2-Wire VG Loop/Port Combo - Zone 1		1			10.79									
	2-Wire VG Loop/Port Combo - Zone 2		2			15.52									
	2-Wire VG Loop/Port Combo - Zone 3		3			31.74									
	<b>UNE Loop Rates</b>														
	2-Wire Voice Grade Loop (SL1) - Zone 1		1	UEPBX	UEPLX	9.64									
	2-Wire Voice Grade Loop (SL1) - Zone 2		2	UEPBX	UEPLX	14.37									
	2-Wire Voice Grade Loop (SL1) - Zone 3		3	UEPBX	UEPLX	30.59									
	<b>2-Wire Voice Grade Line Port (Bus)</b>														
	2-Wire voice unbundled port without Caller ID - bus			UEPBX	UEPBL	1.15	21.29	15.49	2.85	2.67		7.86			
	2-Wire voice unbundled port with Caller + E484 ID - bus			UEPBX	UEPBC	1.15	21.29	15.49	2.85	2.67		7.86			
	2-Wire voice unbundled port outgoing only - bus			UEPBX	UEPBO	1.15	21.29	15.49	2.85	2.67		7.86			
	2-Wire voice Grade unbundled Kentucky extended local dialing parity port with Caller ID - bus			UEPBX	UEPBM	1.15	21.29	15.49	2.85	2.67		7.86			
	2-Wire voice unbundled incoming only port with Caller ID - Bus			UEPBX	UEPB1	1.15	21.29	15.49	2.85	2.67		7.86			
	2-Wire Voice Unbundled Kentucky Business Dialing Plan without Caller ID			UEPBX	UEPWF	1.15	21.29	15.49	2.85	2.67		7.86			
	2-Wire voice unbundled Incoming Only Port without Caller ID Capability			UEPBX	UEPBE	1.15	21.29	15.49	2.85	2.67		7.86			
	<b>LOCAL NUMBER PORTABILITY</b>														
	Local Number Portability (1 per port)			UEPBX	LNPCX	0.35									
	<b>FEATURES</b>														
	All Features Offered			UEPBX	UEPVF	0.00	0.00	0.00				7.86			
	<b>NONRECURRING CHARGES (NRCs) - CURRENTLY COMBINED</b>														
	2-Wire Voice Grade Loop / Line Port Combination - Conversion - Switch-as-is			UEPBX	USAC2		0.10	0.10				7.86			
	2-Wire Voice Grade Loop / Line Port Combination - Conversion - Switch with change			UEPBX	USACC		0.10	0.10				7.86			
	<b>ADDITIONAL NRCs</b>														
	2-Wire Voice Grade Loop/Line Port Combination - Subsequent Activity			UEPBX	USAS2		0.00	0.00				7.86			
	<b>2-WIRE VOICE GRADE LOOP WITH 2-WIRE LINE PORT (RES - PBX)</b>														

UNBUNDLED NETWORK ELEMENTS - Kentucky										Attachment: 2		Exhibit: B			
CATEGORY	RATE ELEMENTS	Interim	Zone	BCS	USOC	RATES (\$)	Svc Order Submitted Elec per LSR	Svc Order Submitted Manually per LSR	Incremental Charge - Manual Svc Order vs. Electronic-1st	Incremental Charge - Manual Svc Order vs. Electronic-Add'l	Incremental Charge - Manual Svc Order vs. Electronic-Disc 1st	Incremental Charge - Manual Svc Order vs. Electronic-Disc Add'l			
													Rec	Nonrecurring	
										SOMEc	SOMAN	SOMAN	SOMAN	SOMAN	SOMAN
<b>UNE Port/Loop Combination Rates</b>															
	2-Wire VG Loop/Port Combo - Zone 1		1			10.79									
	2-Wire VG Loop/Port Combo - Zone 2		2			15.52									
	2-Wire VG Loop/Port Combo - Zone 3		3			31.74									
<b>UNE Loop Rates</b>															
	2-Wire Voice Grade Loop (SL 1) - Zone 1		1	UEPRG	UEPLX	9.64									
	2-Wire Voice Grade Loop (SL 1) - Zone 2		2	UEPRG	UEPLX	14.37									
	2-Wire Voice Grade Loop (SL 1) - Zone 3		3	UEPRG	UEPLX	30.59									
<b>2-Wire Voice Grade Line Port Rates (RES - PBX)</b>															
	2-Wire VG Unbundled Combination 2-Way PBX Trunk Port - Res			UEPRG	UEPRD	1.15	21.29	15.49	2.85	2.67		7.86			
<b>LOCAL NUMBER PORTABILITY</b>															
	Local Number Portability (1 per port)			UEPRG	LNPCP	3.15	0.00	0.00				7.86			
<b>FEATURES</b>															
	All Features Offered			UEPRG	UEPVF	0.00	0.00	0.00				7.86			
<b>NONRECURRING CHARGES (NRCs) - CURRENTLY COMBINED</b>															
	2-Wire Voice Grade Loop/ Line Port Combination (PBX) - Conversion - Switch-As-Is			UEPRG	USAC2		8.45	1.91				7.86			
	2-Wire Voice Grade Loop/ Line Port Combination (PBX) - Conversion - Switch with Change			UEPRG	USACC		8.45	1.91				7.86			
<b>ADDITIONAL NRCs</b>															
	2-Wire Voice Grade Loop/ Line Port Combination (PBX) - Subsequent Activity			UEPRG	USAS2	0.00	0.00	0.00				7.86			
	PBX Subsequent Activity - Change/Rearrange Multiline Hunt Group						7.86	7.86				7.86			
<b>2-WIRE VOICE GRADE LOOP WITH 2-WIRE LINE PORT (BUS - PBX)</b>															
<b>UNE Port/Loop Combination Rates</b>															
	2-Wire VG Loop/Port Combo - Zone 1		1			10.79									
	2-Wire VG Loop/Port Combo - Zone 2		2			15.52									
	2-Wire VG Loop/Port Combo - Zone 3		3			31.74									
<b>UNE Loop Rates</b>															
	2-Wire Voice Grade Loop (SL 1) - Zone 1		1	UEPPX	UEPLX	9.64									
	2-Wire Voice Grade Loop (SL 1) - Zone 2		2	UEPPX	UEPLX	14.37									
	2-Wire Voice Grade Loop (SL 1) - Zone 3		3	UEPPX	UEPLX	30.59									
<b>2-Wire Voice Grade Line Port Rates (BUS - PBX)</b>															
	Line Side Unbundled Combination 2-Way PBX Trunk Port - Bus			UEPPX	UEPPC	1.15	21.29	15.49	2.85	2.67		7.86			
	Line Side Unbundled Outward PBX Trunk Port - Bus			UEPPX	UEPPO	1.15	21.29	15.49	2.85	2.67		7.86			
	Line Side Unbundled Incoming PBX Trunk Port - Bus			UEPPX	UEPP1	1.15	21.29	15.49	2.85	2.67		7.86			
	2-Wire Voice Unbundled PBX LD Terminal Ports			UEPPX	UEPLD	1.15	21.29	15.49	2.85	2.67		7.86			
	2-Wire Voice Unbundled 2-Way Combination PBX Usage Port			UEPPX	UEPXA	1.15	21.29	15.49	2.85	2.67		7.86			
	2-Wire Voice Unbundled PBX Toll Terminal Hotel Ports			UEPPX	UEPXB	1.15	21.29	15.49	2.85	2.67		7.86			
	2-Wire Voice Unbundled PBX LD DDD Terminals Port			UEPPX	UEPXC	1.15	21.29	15.49	2.85	2.67		7.86			
	2-Wire Voice Unbundled PBX LD Terminal Switchboard Port			UEPPX	UEPXD	1.15	21.29	15.49	2.85	2.67		7.86			
	2-Wire Voice Unbundled PBX LD Terminal Switchboard IDD Capable Port			UEPPX	UEPXE	1.15	21.29	15.49	2.85	2.67		7.86			
	2-Wire Voice Unbundled 2-Way PBX Kentucky Room Area Calling Port without LUD			UEPPX	UEPXF	1.15	21.29	15.49	2.85	2.67		7.86			
	2-Wire Voice Unbundled PBX Kentucky LUD Area Calling Port			UEPPX	UEPXF	1.15	21.29	15.49	2.85	2.67		7.86			
	2-Wire Voice Unbundled PBX Kentucky Premium Calling Port			UEPPX	UEPXH	1.15	21.29	15.49	2.85	2.67		7.86			
	2-Wire Voice Unbundled 2-Way Kentucky Area Calling Port without LUD			UEPPX	UEPXJ	1.15	21.29	15.49	2.85	2.67		7.86			
	2-Wire Voice Unbundled 2-Way PBX Hotel/Hospital Economy Administrative Calling Port			UEPPX	UEPXL	1.15	21.29	15.49	2.85	2.67		7.86			
	2-Wire Voice Unbundled 2-Way PBX Hotel/Hospital Economy Room Calling Port			UEPPX	UEPXM	1.15	21.29	15.49	2.85	2.67		7.86			
	2-Wire Voice Unbundled 1-Way Outgoing PBX Hotel/Hospital Discount Room Calling Port			UEPPX	UEPXO	1.15	21.29	15.49	2.85	2.67		7.86			
	2-Wire Voice Unbundled 1-Way Outgoing PBX Measured Port			UEPPX	UEPXS	1.15	21.29	15.49	2.85	2.67		7.86			

UNBUNDLED NETWORK ELEMENTS - Kentucky										Attachment: 2		Exhibit: B			
CATEGORY	RATE ELEMENTS	Interim	Zone	BCS	USOC	RATES (\$)				Svc Order Submitted Elec per LSR	Svc Order Submitted Manually per LSR	Incremental Charge - Manual Svc Order vs. Electronic-1st	Incremental Charge - Manual Svc Order vs. Electronic-Add'l	Incremental Charge - Manual Svc Order vs. Electronic-Disc 1st	Incremental Charge - Manual Svc Order vs. Electronic-Disc Add'l
						Rec	Nonrecurring		Nonrecurring Disconnect						
							First	Add'l	First	Add'l	SOMEc	SOMAN	SOMAN	SOMAN	SOMAN
<b>LOCAL NUMBER PORTABILITY</b>															
	Local Number Portability (1 per port)			UEPPX	LNPCP	3.15	0.00	0.00							
<b>FEATURES</b>															
	All Features Offered			UEPPX	UEPVF	0.00	0.00	0.00				7.86			
<b>NONRECURRING CHARGES (NRCs) - CURRENTLY COMBINED</b>															
	2-Wire Voice Grade Loop/ Line Port Combination (PBX) - Conversion - Switch-As-Is			UEPPX	USAC2		8.45	1.91				7.86			
	2-Wire Voice Grade Loop/ Line Port Combination (PBX) - Conversion - Switch with Change			UEPPX	USACC		8.45	1.91				7.86			
<b>ADDITIONAL NRCs</b>															
	2-Wire Voice Grade Loop/ Line Port Combination (PBX) - Subsequent Activity			UEPPX	USAS2	0.00	0.00	0.00				7.86			
	PBX Subsequent Activity - Change/Rearrange Multiline Hunt Group						7.86	7.86				7.86			
<b>2-WIRE VOICE GRADE LOOP WITH 2-WIRE ANALOG LINE COIN PORT UNE Port/Loop Combination Rates</b>															
	2-Wire VG Coin Port/Loop Combo - Zone 1		1			10.79									
	2-Wire VG Coin Port/Loop Combo - Zone 2		2			15.52									
	2-Wire VG Coin Port/Loop Combo - Zone 3		3			31.74									
<b>UNE Loop Rates</b>															
	2-Wire Voice Grade Loop (SL1) - Zone 1		1	UEPCO	UEPLX	9.64									
	2-Wire Voice Grade Loop (SL1) - Zone 2		2	UEPCO	UEPLX	14.37									
	2-Wire Voice Grade Loop (SL1) - Zone 3		3	UEPCO	UEPLX	30.59									
<b>2-Wire Voice Grade Line Ports (COIN)</b>															
	2-Wire Coin 2-Way without Operator Screening and without Blocking (AL, KY, LA, MS)			UEPCO	UEPRF	1.15	21.29	15.49	2.85	2.67		7.86			
	2-Wire Coin 2-Way with Operator Screening (AL, KY)			UEPCO	UEPRE	1.15	21.29	15.49	2.85	2.67		7.86			
	2-Wire Coin 2-Way with Operator Screening and Blocking: 011, 900/976, 1+DDD (AL, KY, LA, MS)			UEPCO	UEPRA	1.15	21.29	15.49	2.85	2.67		7.86			
	2-Wire Coin 2-Way with Operator Screening and 011 Blocking (KY)			UEPCO	UEPKA	1.15	21.29	15.49	2.85	2.67		7.86			
	2-Wire Coin 2-Way with Operator Screening & Blocking: 900/976, 1+DDD, 011+, & Local (AL, KY, LA, MS)			UEPCO	UEPCD	1.15	21.29	15.49	2.85	2.67		7.86			
	2-Wire Coin Outward without Blocking and without Operator Screening (KY, LA, MS)			UEPCO	UEPRN	1.15	21.29	15.49	2.85	2.67		7.86			
	2-Wire Coin Outward with Operator Screening and 011 Blocking (GA, KY, MS)			UEPCO	UEPRJ	1.15	21.29	15.49	2.85	2.67		7.86			
	2-Wire Coin Outward with Operator Screening and Blocking: 011, 900/976, 1+DDD (AL, KY, LA, MS)			UEPCO	UEPRH	1.15	21.29	15.49	2.85	2.67		7.86			
	2-Wire Coin Outward Operator Screening & Blocking: 900/976, 1+DDD, 011+, and Local (AL, KY, LA, MS)			UEPCO	UEPCN	1.15	21.29	15.49	2.85	2.67		7.86			
	2-Wire 2-Way Smartline with 900/976 (all states except LA)			UEPCO	UEPCK	1.15	21.29	15.49	2.85	2.67		7.86			
	2-Wire Coin Outward Smartline with 900/976 (all states except LA)			UEPCO	UEPCR	1.15	21.29	15.49	2.85	2.67		7.86			
<b>ADDITIONAL UNE COIN PORT/LOOP (RC)</b>															
	UNE Coin Port/Loop Combo Usage (Flat Rate)			UEPCO	URECU	2.57	0.00	0.00	0.00	0.00					
<b>LOCAL NUMBER PORTABILITY</b>															
	Local Number Portability (1 per port)			UEPCO	LNPCX	0.35									
<b>NONRECURRING CHARGES - CURRENTLY COMBINED</b>															
	2-Wire Voice Grade Loop / Line Port Combination - Conversion - Switch-as-is			UEPCO	USAC2		0.10	0.10				7.86			
	2-Wire Voice Grade Loop / Line Port Combination - Conversion - Switch with change			UEPCO	USACC		0.10	0.10				7.86			
<b>ADDITIONAL NRCs</b>															
	2-Wire Voice Grade Loop/Line Port Combination - Subsequent Activity			UEPCO	USAS2		0.00	0.00				7.86			
<b>2-WIRE VOICE LOOP/ 2WIRE VOICE GRADE IO TRANSPORT/ 2-WIRE LINE PORT (RES)</b>															
<b>UNE Port/Loop Combination Rates</b>															
	2-Wire VG Loop/IO Tranport/Port Combo - Zone 1		1			13.90									

UNBUNDLED NETWORK ELEMENTS - Kentucky							Attachment: 2		Exhibit: B							
CATEGORY	RATE ELEMENTS	Interim	Zone	BCS	USOC	RATES (\$)	Svc Order Submitted Elec per LSR	Svc Order Submitted Manually per LSR	Incremental Charge - Manual Svc Order vs. Electronic-1st	Incremental Charge - Manual Svc Order vs. Electronic-Add'l	Incremental Charge - Manual Svc Order vs. Electronic-Disc 1st	Incremental Charge - Manual Svc Order vs. Electronic-Disc Add'l				
							Rec	Nonrecurring		Nonrecurring Disconnect		OSS Rates(\$)				
							First	Add'l	First	Add'l	SOMEc	SOMAN	SOMAN	SOMAN	SOMAN	SOMAN
	2-Wire VG Loop/IO Transport/Port Combo - Zone 2		2			18.68										
	2-Wire VG Loop/IO Transport/Port Combo - Zone 3		3			34.45										
<b>UNE Loop Rates</b>																
	2-Wire Voice Grade Loop (SL2) - Zone 1		1	UEPFR	UECF2	12.67										
	2-Wire Voice Grade Loop (SL2) - Zone 2		2	UEPFR	UECF2	17.45										
	2-Wire Voice Grade Loop (SL2) - Zone 3		3	UEPFR	UECF2	33.22										
<b>2-Wire Voice Grade Line Port Rates (Res)</b>																
	2-Wire voice unbundled port - residence			UEPFR	UEPRL	1.23	128.96	64.11	61.92	9.97		7.86				
	2-Wire voice unbundled port with Caller ID - res			UEPFR	UEPRC	1.23	128.96	64.11	61.92	9.97		7.86				
	2-Wire voice unbundled port outgoing only - res			UEPFR	UEPRO	1.23	128.96	64.11	61.92	9.97		7.86				
	2-Wire voice Grade unbundled Kentucky extended local dialing parity port with Caller ID - res			UEPFR	UEPRM	1.23	128.96	64.11	61.92	9.97		7.86				
	2-Wire voice unbundles res, low usage line port with Caller ID (LUM)			UEPFR	UEPAP	1.23	128.96	64.11	61.92	9.97		7.86				
	2-Wire Voice Unbundled Kentucky Residence Dialing Plan without Caller ID			UEPFR	UEPWE	1.23	128.96	64.11	61.92	9.97		7.86				
<b>INTEROFFICE TRANSPORT</b>																
	Interoffice Transport - Dedicated - 2 Wire Voice Grade - Facility Termination			UEPFR	U1TV2	23.95	98.09	53.67	56.31	22.42		7.86				
	Interoffice Transport - Dedicated - 2 Wire Voice Grade - Per Mile or Fraction Mile			UEPFR	1L5XX	0.0095										
<b>FEATURES</b>																
	All Features Offered			UEPFR	UEPVF	0.00	0.00	0.00				7.86				
<b>LOCAL NUMBER PORTABILITY</b>																
	Local Number Portability (1 per port)			UEPFR	LNPCX	0.35										
<b>NONRECURRING CHARGES (NRCs) - CURRENTLY COMBINED</b>																
	2-Wire Loop / Dedicated IO Transport / 2 Wire Line Port Combination - Conversion - Switch-as-is			UEPFR	USAC2		9.03	1.87				7.86				
	2-Wire Loop / Dedicated IO Transport / 2 Wire Line Port Combination - Conversion - Switch-With-Change			UEPFR	USACC		9.03	1.87				7.86				
<b>2-WIRE VOICE LOOP/ 2WIRE VOICE GRADE IO TRANSPORT/ 2-WIRE LINE PORT (BUS)</b>																
<b>UNE Port/Loop Combination Rates</b>																
	2-Wire VG Loop/IO Transport/Port Combo - Zone 1		1			13.90										
	2-Wire VG Loop/IO Transport/Port Combo - Zone 2		2			18.68										
	2-Wire VG Loop/IO Transport/Port Combo - Zone 3		3			34.45										
<b>UNE Loop Rates</b>																
	2-Wire Voice Grade Loop (SL2) - Zone 1		1	UEPFB	UECF2	12.67										
	2-Wire Voice Grade Loop (SL2) - Zone 2		2	UEPFB	UECF2	17.45										
	2-Wire Voice Grade Loop (SL2) - Zone 3		3	UEPFB	UECF2	33.22										
<b>2-Wire Voice Grade Line Port (Bus)</b>																
	2-Wire voice unbundled port without Caller ID - bus			UEPFB	UEPBL	1.23	128.96	64.11	61.92	9.97		7.86				
	2-Wire voice unbundled port with Caller + E484 ID - bus			UEPFB	UEPBC	1.23	128.96	64.11	61.92	9.97		7.86				
	2-Wire voice unbundled port outgoing only - bus			UEPFB	UEPBO	1.23	128.96	64.11	61.92	9.97		7.86				
	2-Wire voice Grade unbundled Kentucky extended local dialing parity port with Caller ID - bus			UEPFB	UEPBM	1.23	128.96	64.11	61.92	9.97		7.86				
	2-Wire voice unbundled incoming only port with Caller ID - Bus			UEPFB	UEPB1	1.23	128.96	64.11	61.92	9.97		7.86				
	2-Wire Voice Unbundled Kentucky Business Dialing Plan without Caller ID			UEPFB	UEPWF	1.23	128.96	64.11	61.92	9.97		7.86				
<b>LOCAL NUMBER PORTABILITY</b>																
	Local Number Portability (1 per port)			UEPFB	LNPCX	0.35										
<b>INTEROFFICE TRANSPORT</b>																
	Interoffice Transport - Dedicated - 2 Wire Voice Grade - Facility Termination			UEPFB	U1TV2	23.95	98.09	53.67	56.31	22.42		7.86				
	Interoffice Transport - Dedicated - 2 Wire Voice Grade - Per Mile or Fraction Mile			UEPFB	1L5XX	0.0095										
<b>FEATURES</b>																
	All Features Offered			UEPFB	UEPVF	0.00	0.00	0.00				7.86				
<b>NONRECURRING CHARGES (NRCs) - CURRENTLY COMBINED</b>																

UNBUNDLED NETWORK ELEMENTS - Kentucky							Attachment: 2		Exhibit: B			
CATEGORY	RATE ELEMENTS	Interim	Zone	BCS	USOC	RATES (\$)	Svc Order Submitted Elec per LSR	Svc Order Submitted Manually per LSR	Incremental Charge - Manual Svc Order vs. Electronic-1st	Incremental Charge - Manual Svc Order vs. Electronic-Add'l	Incremental Charge - Manual Svc Order vs. Electronic-Disc 1st	Incremental Charge - Manual Svc Order vs. Electronic-Disc Add'l
							Rec	Nonrecurring		Nonrecurring Disconnect		OSS Rates(\$)
	2-Wire Loop / Dedicated IO Transport / 2 Wire Line Port Combination - Conversion - Switch-as-is			UEPFB	USAC2							7.86
	2-Wire Loop / Dedicated IO Transport / 2 Wire Line Port Combination - Conversion - Switch with change			UEPFB	USACC							7.86
	<b>2-WIRE VOICE GRADE LOOP WITH 2-WIRE LINE PORT (BUS - PBX)</b>											
	<b>UNE Port/Loop Combination Rates</b>											
	2-Wire VG Loop/IO Transport/Port Combo - Zone 1		1									13.90
	2-Wire VG Loop/IO Transport/Port Combo - Zone 2		2									18.68
	2-Wire VG Loop/IO Transport/Port Combo - Zone 3		3									34.45
	<b>UNE Loop Rates</b>											
	2-Wire Voice Grade Loop (SL2) - Zone 1		1	UEPFP	UECF2							12.67
	2-Wire Voice Grade Loop (SL2) - Zone 2		2	UEPFP	UECF2							17.45
	2-Wire Voice Grade Loop (SL2) - Zone 3		3	UEPFP	UECF2							33.22
	<b>2-Wire Voice Grade Line Port Rates (BUS - PBX)</b>											
	Line Side Unbundled Combination 2-Way PBX Trunk Port - Bus			UEPFP	UEPPC	1.23	164.27	78.65	75.05	8.73		7.86
	Line Side Unbundled Outward PBX Trunk Port - Bus			UEPFP	UEPPO	1.23	164.27	78.65	75.05	8.73		7.86
	Line Side Unbundled Incoming PBX Trunk Port - Bus			UEPFP	UEPP1	1.23	164.27	78.65	75.05	8.73		7.86
	2-Wire Voice Unbundled PBX LD Terminal Ports			UEPFP	UEPLD	1.23	164.27	78.65	75.05	8.73		7.86
	2-Wire Voice Unbundled 2-Way Combination PBX Usage Port			UEPFP	UEPXA	1.23	164.27	78.65	75.05	8.73		7.86
	2-Wire Voice Unbundled PBX Toll Terminal Hotel Ports			UEPFP	UEPXB	1.23	164.27	78.65	75.05	8.73		7.86
	2-Wire Voice Unbundled PBX LD DDD Terminals Port			UEPFP	UEPXC	1.23	164.27	78.65	75.05	8.73		7.86
	2-Wire Voice Unbundled PBX LD Terminal Switchboard Port			UEPFP	UEPXD	1.23	164.27	78.65	75.05	8.73		7.86
	2-Wire Voice Unbundled PBX LD Terminal Switchboard IDD Capable Port			UEPFP	UEPXE	1.23	164.27	78.65	75.05	8.73		7.86
	2-Wire Voice Unbundled 2-Way PBX Kentucky Room Area Calling Port without LUD			UEPFP	UEPXF	1.23	164.27	78.65	75.05	8.73		7.86
	2-Wire Voice Unbundled PBX Kentucky LUD Area Calling Port			UEPFP	UEPXG	1.23	164.27	78.65	75.05	8.73		7.86
	2-Wire Voice Unbundled PBX Kentucky Premium Calling Port			UEPFP	UEPXH	1.23	164.27	78.65	75.05	8.73		7.86
	2-Wire Voice Unbundled 2-Way Kentucky Area Calling Port without LUD			UEPFP	UEPXJ	1.23	164.27	78.65	75.05	8.73		7.86
	2-Wire Voice Unbundled 2-Way PBX Hotel/Hospital Economy Administrative Calling Port			UEPFP	UEPXL	1.23	164.27	78.65	75.05	8.73		7.86
	2-Wire Voice Unbundled 2-Way PBX Hotel/Hospital Economy Room Calling Port			UEPFP	UEPXM	1.23	164.27	78.65	75.05	8.73		7.86
	2-Wire Voice Unbundled 1-Way Outgoing PBX Hotel/Hospital Discount Room Calling Port			UEPFP	UEPXO	1.23	164.27	78.65	75.05	8.73		7.86
	2-Wire Voice Unbundled 1-Way Outgoing PBX Measured Port			UEPFP	UEPXS	1.23	164.27	78.65	75.05	8.73		7.86
	<b>LOCAL NUMBER PORTABILITY</b>											
	Local Number Portability (1 per port)			UEPFP	LNPCP	3.15		0.00				
	<b>INTEROFFICE TRANSPORT</b>											
	Interoffice Transport - Dedicated - 2 Wire Voice Grade - Facility Termination			UEPFP	U1TV2	23.95	98.09	53.67	56.31	22.42		7.86
	Interoffice Transport - Dedicated - 2 Wire Voice Grade - Per Mile or Fraction Mile			UEPFP	1L5XX	0.0095						
	<b>FEATURES</b>											
	All Features Offered			UEPFP	UEPVF	0.00	0.00	0.00				7.86
	<b>NONRECURRING CHARGES (NRCs) - CURRENTLY COMBINED</b>											
	2-Wire Loop / Dedicated IO Transport / 2 Wire Line Port Combination - Conversion - Switch-as-is			UEPFP	USAC2		9.03	1.87				7.86
	2-Wire Loop / Dedicated IO Transport / 2 Wire Line Port Combination - Conversion - Switch with change			UEPFP	USACC		9.03	1.87				7.86
	<b>UNBUNDLED PORT/LOOP COMBINATIONS - COST BASED RATES</b>											
	<b>2-WIRE VOICE GRADE LOOP- BUS ONLY - WITH 2-WIRE DID TRUNK PORT</b>											
	<b>UNE Port/Loop Combination Rates</b>											
	2-Wire VG Loop/2-Wire DID Trunk Port Combo - UNE Zone 1		1									21.30
	2-Wire VG Loop/2-Wire DID Trunk Port Combo - UNE Zone 2		2									26.08
	2-Wire VG Loop/2-Wire DID Trunk Port Combo - UNE Zone 3		3									41.85
	<b>UNE Loop Rates</b>											

UNBUNDLED NETWORK ELEMENTS - Kentucky										Attachment: 2		Exhibit: B								
CATEGORY	RATE ELEMENTS	Interim	Zone	BCS	USOC	RATES (\$)	Svc Order Submitted Elec per LSR	Svc Order Submitted Manually per LSR	Incremental Charge - Manual Svc Order vs. Electronic-1st	Incremental Charge - Manual Svc Order vs. Electronic-Add'l	Incremental Charge - Manual Svc Order vs. Electronic-Disc 1st	Incremental Charge - Manual Svc Order vs. Electronic-Disc Add'l	OSS Rates(\$)							
													Rec	Nonrecurring		Nonrecurring Disconnect		SOMEc	SOMAN	SOMAN
													First	Add'l	First	Add'l				
	2-Wire Analog Voice Grade Loop - (SL2) - UNE Zone 1		1	UEPPX	UECD1	12.67														
	2-Wire Analog Voice Grade Loop - (SL2) - UNE Zone 2		2	UEPPX	UECD1	17.45														
	2-Wire Analog Voice Grade Loop - (SL2) - UNE Zone 3		3	UEPPX	UECD1	33.22														
<b>UNE Port Rate</b>																				
	Exchange Ports - 2-Wire DID Port			UEPPX	UEPD1	8.63								336.11	27.75	132.37	9.31			7.86
<b>NONRECURRING CHARGES - CURRENTLY COMBINED</b>																				
	2-Wire Voice Grade Loop / 2-Wire DID Trunk Port Conversion with BellSouth Allowable Changes			UEPPX	USA1C									7.85	1.87					7.86
<b>ADDITIONAL NRCs</b>																				
	2-Wire DID Subsequent Activity - Add Trunks, Per Trunk			UEPPX	USAS1									32.25	32.25					7.86
<b>Telephone Number/Trunk Group Establishment Charges</b>																				
	DID Trunk Termination (One Per Port)			UEPPX	NDT	0.00								0.00	0.00	0.00				7.86
	Additional DID Numbers for each Group of 20 DID Numbers			UEPPX	ND4	0.00								0.00	0.00	0.00				7.86
	DID Numbers, Non- consecutive DID Numbers , Per Number			UEPPX	ND5	0.00								0.00	0.00	0.00				7.86
	Reserve Non-Consecutive DID numbers			UEPPX	ND6	0.00								0.00	0.00	0.00				7.86
	Reserve DID Numbers			UEPPX	NDV	0.00								0.00	0.00	0.00				7.86
<b>LOCAL NUMBER PORTABILITY</b>																				
	Local Number Portability (1 per port)			UEPPX	LNPCP	3.15								0.00	0.00					
<b>2-WIRE ISDN DIGITAL GRADE LOOP WITH 2-WIRE ISDN DIGITAL LINE SIDE PORT</b>																				
<b>UNE Port/Loop Combination Rates</b>																				
	2W ISDN Digital Grade Loop/2W ISDN Digital Line Side Port - UNE Zone 1		1	UEPPB	UEPPR	25.69														
	2W ISDN Digital Grade Loop/2W ISDN Digital Line Side Port - UNE Zone 2		2	UEPPB	UEPPR	31.92														
	2W ISDN Digital Grade Loop/2W ISDN Digital Line Side Port - UNE Zone 3		3	UEPPB	UEPPR	50.21														
<b>UNE Loop Rates</b>																				
	2-Wire ISDN Digital Grade Loop - UNE Zone 1		1	UEPPB	UEPPR	USL2X	16.10													7.86
	2-Wire ISDN Digital Grade Loop - UNE Zone 2		2	UEPPB	UEPPR	USL2X	22.33													7.86
	2-Wire ISDN Digital Grade Loop - UNE Zone 3		3	UEPPB	UEPPR	USL2X	40.63													7.86
<b>UNE Port Rate</b>																				
	Exchange Port - 2-Wire ISDN Line Side Port			UEPPB	UEPPR	UEPPB	9.59							320.53	289.13	92.19	17.56			7.86
<b>NONRECURRING CHARGES - CURRENTLY COMBINED</b>																				
	2-Wire ISDN Digital Grade Loop / 2-Wire ISDN Line Side Port Combination - Conversion			UEPPB	UEPPR	USACB	0.00							22.77	17.00					7.86
<b>ADDITIONAL NRCs</b>																				
<b>LOCAL NUMBER PORTABILITY</b>																				
	Local Number Portability (1 per port)			UEPPB	UEPPR	LNPCX	0.35							0.00	0.00					
<b>B-CHANNEL USER PROFILE ACCESS:</b>																				
	CVS/CSD (DMS/5ESS)			UEPPB	UEPPR	U1UCA	0.00							0.00	0.00	0.00				
	CVS (EWSD)			UEPPB	UEPPR	U1UCB	0.00							0.00	0.00	0.00				
	CSD			UEPPB	UEPPR	U1UCC	0.00							0.00	0.00	0.00				
<b>B-CHANNEL AREA PLUS USER PROFILE ACCESS: (AL,KY,LA,MS SC,MS, &amp; TN)</b>																				
	CVS/CSD (DMS/5ESS)			UEPPB	UEPPR	U1UCD	0.00							0.00	0.00	0.00				
	CVS (EWSD)			UEPPB	UEPPR	U1UCE	0.00							0.00	0.00	0.00				
	CSD			UEPPB	UEPPR	U1UCF	0.00							0.00	0.00	0.00				
<b>USER TERMINAL PROFILE</b>																				
	User Terminal Profile (EWSD only)			UEPPB	UEPPR	U1UMA	0.00							0.00	0.00	0.00				
<b>VERTICAL FEATURES</b>																				
	All Vertical Features - One per Channel B User Profile			UEPPB	UEPPR	UEPVF	0.00							0.00	0.00	0.00				
<b>INTEROFFICE CHANNEL MILEAGE</b>																				
	Interoffice Channel mileage each, including first mile and facilities termination			UEPPB	UEPPR	M1GNC	29.12							47.34	31.78	22.77	8.75			7.86
	Interoffice Channel mileage each, additional mile			UEPPB	UEPPR	M1GNM	0.01							0.00	0.00					7.86
<b>4-WIRE DS1 DIGITAL LOOP WITH 4-WIRE ISDN DS1 DIGITAL TRUNK PORT</b>																				
<b>UNE Port/Loop Combination Rates</b>																				
	4W DS1 Digital Loop/4W ISDN DS1 Digital Trunk Port - UNE Zone 1		1	UEPPP			170.06													

UNBUNDLED NETWORK ELEMENTS - Kentucky							Attachment: 2		Exhibit: B						
CATEGORY	RATE ELEMENTS	Interim	Zone	BCS	USOC	RATES (\$)	Svc Order Submitted Elec per LSR	Svc Order Submitted Manually per LSR	Incremental Charge - Manual Svc Order vs. Electronic-1st	Incremental Charge - Manual Svc Order vs. Electronic-Add'l	Incremental Charge - Manual Svc Order vs. Electronic-Disc 1st	Incremental Charge - Manual Svc Order vs. Electronic-Disc Add'l			
													Rec	Nonrecurring	
										SOMEc	SOMAN	SOMAN	SOMAN	SOMAN	SOMAN
	4W DS1 Digital Loop/4W ISDN DS1 Digital Trunk Port - UNE Zone 2		2	UEPPP		197.70									
	4W DS1 Digital Loop/4W ISDN DS1 Digital Trunk Port - UNE Zone 3		3	UEPPP		381.35									
<b>UNE Loop Rates</b>															
	4-Wire DS1 Digital Loop - UNE Zone 1		1	UEPPP	USL4P	86.47									7.86
	4-Wire DS1 Digital Loop - UNE Zone 2		2	UEPPP	USL4P	114.10									7.86
	4-Wire DS1 Digital Loop - UNE Zone 3		3	UEPPP	USL4P	297.76									7.86
<b>UNE Port Rate</b>															
	Exchange Ports - 4-Wire ISDN DS1 Port			UEPPP	UEPPP	83.59		736.16	382.74	159.48	48.82				7.86
<b>NONRECURRING CHARGES - CURRENTLY COMBINED</b>															
	4-Wire DS1 Digital Loop / 4-Wire ISDN DS1 Digital Trunk Port Combination - Conversion -Switch-as-is			UEPPP	USACP	0.00		81.70	61.37						7.86
<b>ADDITIONAL NRCs</b>															
	4-Wire DS1 Loop/4-W ISDN Digtl Trk Port - Subsqst Actvy-Inward/two way Tel Nos. (except NC)			UEPPP	PR7TF			0.54							7.86
	4-Wire DS1 Loop / 4-Wire ISDN DS1 Digital Trunk Port - Outward Tel Numbers (All States except NC)			UEPPP	PR7TO			12.71	12.71						7.86
	4-Wire DS1 Loop / 4-Wire ISDN DS1 Digital Trk Port - Subsequent Inward Tel Numbers			UEPPP	PR7ZT			25.41	25.41						7.86
<b>LOCAL NUMBER PORTABILITY</b>															
	Local Number Portability (1 per port)			UEPPP	LNPCN	1.75									
<b>INTERFACE (Provisioning Only)</b>															
	Voice/Data			UEPPP	PR71V	0.00		0.00	0.00						
	Digital Data			UEPPP	PR71D	0.00		0.00	0.00						
	Inward Data			UEPPP	PR71E	0.00		0.00	0.00						
<b>New or Additional "B" Channel</b>															
	New or Additional - Voice/Data B Channel			UEPPP	PR7BV	0.00		15.48							7.86
	New or Additional - Digital Data B Channel			UEPPP	PR7BF	0.00		15.48							7.86
	New or Additional Inward Data B Channel			UEPPP	PR7BD	0.00		15.48							7.86
<b>CALL TYPES</b>															
	Inward			UEPPP	PR7C1	0.00		0.00	0.00						
	Outward			UEPPP	PR7CO	0.00		0.00	0.00						
	Two-way			UEPPP	PR7CC	0.00		0.00	0.00						
<b>Interoffice Channel Mileage</b>															
	Fixed Each Including First Mile			UEPPP	1LN1A	96.27		105.52	98.46	23.09	20.49				7.86
	Each Airline-Fractional Additional Mile			UEPPP	1LN1B	0.23									
<b>4-WIRE DS1 DIGITAL LOOP WITH 4-WIRE DDITS TRUNK PORT</b>															
<b>UNE Port/Loop Combination Rates</b>															
	4W DS1 Digital Loop/4W DDITS Trunk Port - UNE Zone 1		1	UEPDC		147.99									
	4W DS1 Digital Loop/4W DDITS Trunk Port - UNE Zone 2		2	UEPDC		175.62									
	4W DS1 Digital Loop/4W DDITS Trunk Port - UNE Zone 3		3	UEPDC		359.28									
<b>UNE Loop Rates</b>															
	4-Wire DS1 Digital Loop - UNE Zone 1		1	UEPDC	USLDC	86.47									7.86
	4-Wire DS1 Digital Loop - UNE Zone 2		2	UEPDC	USLDC	114.10									7.86
	4-Wire DS1 Digital Loop - UNE Zone 3		3	UEPDC	USLDC	297.76									7.86
<b>UNE Port Rate</b>															
	4-Wire DDITS Digital Trunk Port			UEPDC	UDD1T	61.52		780.61	375.52	176.19	16.98				7.86
<b>NONRECURRING CHARGES - CURRENTLY COMBINED</b>															
	4-Wire DS1 Digital Loop / 4-Wire DDITS Trunk Port Combination - Switch-as-is			UEPDC	USAC4			92.84	46.70						7.86
	4-Wire DS1 Digital Loop / 4-Wire DDITS Trunk Port Combination - Conversion with DS1 Changes			UEPDC	USAWA			92.84	46.70						7.86
	4-Wire DS1 Digital Loop / 4-Wire DDITS Trunk Port Combination - Conversion with Change - Trunk			UEPDC	USAWB			92.84	46.70						7.86
<b>ADDITIONAL NRCs</b>															
	4-Wire DS1 Loop / 4-Wire DDITS Trunk Port - NRC - Subsequent Channel Activation/Chan - 2-Way Trunk			UEPDC	UDTTA			15.09	15.09						7.86



**UNBUNDLED NETWORK ELEMENTS - Kentucky**

CATEGORY	RATE ELEMENTS	Interim	Zone	BCS	USOC	RATES (\$)	Svc Order Submitted Elec per LSR	Svc Order Submitted Manually per LSR	Attachment: 2		Exhibit: B					
									Incremental Charge - Manual Svc Order vs. Electronic-1st	Incremental Charge - Manual Svc Order vs. Electronic-Add'l	Incremental Charge - Manual Svc Order vs. Electronic-Disc 1st	Incremental Charge - Manual Svc Order vs. Electronic-Disc Add'l				
									Rec	Nonrecurring		Nonrecurring Disconnect		OSS Rates(\$)		
						First	Add'l	First	Add'l	SOMEc	SOMAN	SOMAN	SOMAN	SOMAN	SOMAN	
	4-Wire DS1 Loop / 4-Wire DDITS Trunk Port - Subsequent Channel Activation/Chan - 1-Way Outward Trunk			UEPDC	UDTTB	15.09	15.09				7.86					
	4-Wire DS1 Loop / 4-Wire DDITS Trunk Port - Subsqnt Channel Activation/Chan Inward Trunk w/out DID			UEPDC	UDTTC	15.09	15.09				7.86					
	4-Wire DS1 Loop / 4-Wire DDITS Trunk Port - Subsqnt Chan Activation Per Chan - Inward Trunk with DID			UEPDC	UDTTD	15.09	15.09				7.86					
	4-Wire DS1 Loop / 4-Wire DDITS Trunk Port - Subsqnt Chan Activation / Chan - 2-Way DID w User Trans			UEPDC	UDTTE	15.09	15.09				7.86					
	<b>BIPOLAR 8 ZERO SUBSTITUTION</b>															
	B8ZS -Superframe Format			UEPDC	CCOSF	0.00	730.00				7.86					
	B8ZS - Extended Superframe Format			UEPDC	CCOEF	0.00	730.00				7.86					
	<b>Alternate Mark Inversion</b>															
	AMI -Superframe Format			UEPDC	MCOSF	0.00	0.00									
	AMI - Extended SuperFrame Format			UEPDC	MCOPO	0.00	0.00									
	<b>Telephone Number/Trunk Group Establishment Charges</b>															
	Telephone Number for 2-Way Trunk Group			UEPDC	UDTGX	0.00	0.00				7.86					
	Telephone Number for 1-Way Outward Trunk Group			UEPDC	UDTGY	0.00	0.00				7.86					
	Telephone Number for 1-Way Inward Trunk Group Without DID			UEPDC	UDTGZ	0.00	0.00				7.86					
	DID Numbers for each Group of 20 DID Numbers			UEPDC	ND4	0.00	0.00				7.86					
	DID Numbers, Non- consecutive DID Numbers , Per Number			UEPDC	ND5	0.00	0.00				7.86					
	Reserve Non-Consecutive DID Nos.			UEPDC	ND6	0.00	0.00				7.86					
	Reserve DID Numbers			UEPDC	NDV	0.00	0.00				7.86					
	<b>Dedicated DS1 (Interoffice Channel Mileage) - FX/FCO for 4-Wire DS1 Digital Loop with 4-Wire DDITS Trunk Port</b>															
	Interoffice Channel Mileage - Fixed rate 0-8 miles (Facilities Termination)			UEPDC	1LNO1	96.04	105.52	98.46	23.09	20.49	7.86					
	Interoffice Channel Mileage - Additional rate per mile - 0-8 miles			UEPDC	1LNOA	0.23	0.00	0.00								
	Interoffice Channel Mileage - Fixed rate 9-25 miles (Facilities Termination)			UEPDC	1LNO2	0.00	0.00	0.00								
	Interoffice Channel Mileage - Additional rate per mile - 9-25 miles			UEPDC	1LNOB	0.45	0.00	0.00								
	Interoffice Channel Mileage - Fixed rate 25+ miles (Facilities Termination)			UEPDC	1LNO3	0.00	0.00	0.00								
	Interoffice Channel Mileage - Additional rate per mile - 25+ miles			UEPDC	1LNOC	0.45	0.00	0.00								
	Local Number Portability, per DS0 Activated			UEPDC	LNPCP	3.15	0.00	0.00								
	Central Office Terminating Point			UEPDC	CTG	0.00										
	<b>4-WIRE DS1 LOOP WITH CHANNELIZATION WITH PORT</b>															
	<b>System is 1 DS1 Loop, 1 D4 Channel Bank, and up to 24 Feature Activations</b>															
	<b>Each System can have up to 24 combinations of rates depending on type and number of ports used</b>															
	<b>UNE DS1 Loop</b>															
	4-Wire DS1 Loop - UNE Zone 1		1	UEPMG	USLDC	86.47	0.00	0.00								
	4-Wire DS1 Loop - UNE Zone 2		2	UEPMG	USLDC	114.10	0.00	0.00								
	4-Wire DS1 Loop - UNE Zone 3		3	UEPMG	USLDC	297.76	0.00	0.00								
	<b>UNE DSO Channelization Capacities (D4 Channel Bank Configurations)</b>															
	24 DSO Channel Capacity - 1 per DS1			UEPMG	VUM24	111.16	0.00	0.00			7.86					
	48 DSO Channel Capacity - 1 per 2 DS1s			UEPMG	VUM48	222.32	0.00	0.00			7.86					
	96 DSO Channel Capacity -1per 4 DS1s			UEPMG	VUM96	444.64	0.00	0.00			7.86					
	144 DSO Channel Capacity - 1 per 6 DS1s			UEPMG	VUM14	666.96	0.00	0.00			7.86					
	192 DSO Channel Capacity -1 per 8 DS1s			UEPMG	VUM19	889.28	0.00	0.00			7.86					
	240 DSO Channel Capacity - 1 per 10 DS1s			UEPMG	VUM20	1,111.60	0.00	0.00			7.86					
	288 DSO Channel Capacity - 1 per 12 DS1s			UEPMG	VUM28	1,333.92	0.00	0.00			7.86					
	384 DSO Channel Capacity - 1 per 16 DS1s			UEPMG	VUM38	1,778.56	0.00	0.00			7.86					
	480 DSO Channel Capacity - 1 per 20 DS1s			UEPMG	VUM40	2,223.20	0.00	0.00			7.86					
	576 DSO Channel Capacity -1 per 24 DS1s			UEPMG	VUM57	2,667.84	0.00	0.00			7.86					
	672 DSO Channel Capacity - 1 per 28 DS1s			UEPMG	VUM67	3,112.48	0.00	0.00			7.86					
	<b>Non-Recurring Charges (NRC) Associated with 4-Wire DS1 Loop with Channelization with Port - Conversion Charge Based on a System</b>															
	<b>A Minimum System configuration is One (1) DS1, One (1) D4 Channel Bank, and Up To 24 DSO Ports with Feature Activations.</b>															
	<b>Multiples of this configuration functioning as one are considered Add'l after the minimum system configuration is counted.</b>															

UNBUNDLED NETWORK ELEMENTS - Kentucky							Attachment: 2		Exhibit: B								
CATEGORY	RATE ELEMENTS	Interim	Zone	BCS	USOC	RATES (\$)	Svc Order Submitted Elec per LSR	Svc Order Submitted Manually per LSR	Incremental Charge - Manual Svc Order vs. Electronic-1st	Incremental Charge - Manual Svc Order vs. Electronic-Add'l	Incremental Charge - Manual Svc Order vs. Electronic-Disc 1st	Incremental Charge - Manual Svc Order vs. Electronic-Disc Add'l					
													Rec	Nonrecurring		Nonrecurring Disconnect	
										SOMEc	SOMAN	SOMAN	SOMAN	SOMAN	SOMAN		
	NRC - Conversion (Currently Combined) with or without BellSouth Allowed Changes			UEPMG	USAC4	0.00		94.30	4.24							7.86	
<b>System Additions at End User Locations Where 4-Wire DS1 Loop with Channelization with Port Combination Currently Exists and New (Not Currently Combined) in all states, except in Density Zone 1 of Top 8 MSA's</b>																	
	1 DS1/D4 Channel Bank - Additionally Add NRC for each Port and Assoc Fea Activation			UEPMG	VUMD4	0.00		718.89	469.86	149.83	17.77						7.86
<b>Bipolar 8 Zero Substitution</b>																	
	Clear Channel Capability Format, superframe - Subsequent Activity Only			UEPMG	CCOSF	0.00		0.00	730.00								7.86
	Clear Channel Capability Format - Extended Superframe - Subsequent Activity Only			UEPMG	CCOEF	0.00		0.00	730.00								7.86
<b>Alternate Mark Inversion (AMI)</b>																	
	Superframe Format			UEPMG	MCOSF	0.00		0.00	0.00								
	Extended Superframe Format			UEPMG	MCOPO	0.00		0.00	0.00								
<b>Exchange Ports Associated with 4-Wire DS1 Loop with Channelization with Port Exchange Ports</b>																	
	Line Side Combination Channelized PBX Trunk Port - Business			UEPPX	UEPCX	1.15		0.00	0.00	0.00	0.00						7.86
	Line Side Outward Channelized PBX Trunk Port - Business			UEPPX	UEPOX	1.15		0.00	0.00	0.00	0.00						7.86
	Line Side Inward Only Channelized PBX Trunk Port without DID			UEPPX	UEP1X	1.15		0.00	0.00	0.00	0.00						7.86
	2-Wire Trunk Side Unbundled Channelized DID Trunk Port			UEPPX	UEPDM	8.65		0.00	0.00	0.00	0.00						7.86
	Unbundled Exchange Ports, 2-Wire Channelized - Outdial - (AL, KY, LA, MS, & TN)(Conversion from Network Access Service)			UEPPX	UEPCY	1.15		0.00	0.00	0.00	0.00						7.86
	Unbundled Exchange Ports, 2-Wire Channelized - Combination (AL, KY, LA, MS, & TN) (Conversion from Network Access Service)			UEPPX	UEPCT	1.15		0.00	0.00	0.00	0.00						7.86
	Unbundled Exchange Ports, 2-Wire Channelized - Outdial - Kentucky Only - Calling Plan			UEPPX	UEPCV	1.15		0.00	0.00	0.00	0.00						7.86
	Unbundled Exchange Ports, 2-Wire Channelized - Two Way - Kentucky Only - Calling Plan			UEPPX	UEPCW	1.15		0.00	0.00	0.00	0.00						7.86
<b>Feature Activations - Unbundled Loop Concentration</b>																	
	Feature (Service) Activation for each Line Port Terminated in D4 Bank			UEPPX	1PQWM	0.62		25.40	13.41	4.17	4.15						7.86
	Feature (Service) Activation for each Trunk Port Terminated in D4 Bank			UEPPX	1PQWU	0.62		78.15	19.68	59.05	11.54						7.86
<b>Telephone Number/ Group Establishment Charges for DID Service</b>																	
	DID Trunk Termination (1 per Port)			UEPPX	NDT	0.00		0.00	0.00								7.86
	DID Numbers - groups of 20 - Valid all States			UEPPX	ND4	0.00		0.00	0.00	0.00							7.86
	Non-Consecutive DID Numbers - per number			UEPPX	ND5	0.00		0.00	0.00	0.00							7.86
	Reserve Non-Consecutive DID Numbers			UEPPX	ND6	0.00		0.00	0.00	0.00							7.86
	Reserve DID Numbers			UEPPX	NDV	0.00		0.00	0.00	0.00							7.86
<b>Local Number Portability</b>																	
	Local Number Portability - 1 per port			UEPPX	LNPCP	3.15		0.00	0.00								
<b>FEATURES - Vertical and Optional</b>																	
<b>Local Switching Features Offered with Line Side Ports Only</b>																	
	All Features Available			UEPPX	UEPVF	0.00		0.00	0.00								
<b>UNBUNDLED CENTREX PORT/LOOP COMBINATIONS - COST BASED RATES</b>																	
1. Cost Based Rates are applied where BellSouth is required by FCC and/or State Commission rule to provide Unbundled Local Switching or Switch Ports.																	
2. Features shall apply to the Unbundled Port/Loop Combination - Cost Based Rate section in the same manner as they are applied to the Stand-Alone Unbundled Port section of this Rate Exhibit.																	
3. End Office and Tandem Switching Usage and Common Transport Usage rates in the Port section of this rate exhibit shall apply to all combinations of loop/port network elements except for UNE Coin Port/Loop Combinations.																	
4. The first and additional Port nonrecurring charges apply to Not Currently Combined Combos. For Currently Combined Combos, the nonrecurring charges shall be those identified in the Nonrecurring - Currently Combined sections. Additional NRCs may apply also and are categorized accordingly.																	
5. Market Rates for Unbundled Centrex Port/Loop Combination will be negotiated on an Individual Case Basis, until further notice.																	
<b>UNE-P CENTREX - 1AESS - (Valid in AL,FL,GA,KY,LA,MS,&amp;TN only)</b>																	
<b>2-Wire VG Loop/2-Wire Voice Grade Port (Centrex) Combo</b>																	
<b>UNE Port/Loop Combination Rates (Non-Design)</b>																	

UNBUNDLED NETWORK ELEMENTS - Kentucky							Attachment: 2		Exhibit: B							
CATEGORY	RATE ELEMENTS	Interim	Zone	BCS	USOC	RATES (\$)	Svc Order Submitted Elec per LSR	Svc Order Submitted Manually per LSR	Incremental Charge - Manual Svc Order vs. Electronic-1st	Incremental Charge - Manual Svc Order vs. Electronic-Add'l	Incremental Charge - Manual Svc Order vs. Electronic-Disc 1st	Incremental Charge - Manual Svc Order vs. Electronic-Disc Add'l				
							Rec	Nonrecurring		Nonrecurring Disconnect		OSS Rates(\$)				
							First	Add'l	First	Add'l	SOME C	SOMAN	SOMAN	SOMAN	SOMAN	SOMAN
	2-Wire VG Loop/2-Wire Voice Grade Port (Centrex) Port Combo - Non-Design		1	UEP91		10.79										
	2-Wire VG Loop/2-Wire Voice Grade Port (Centrex)Port Combo - Non-Design		2	UEP91		15.52										
	2-Wire VG Loop/2-Wire Voice Grade Port (Centrex)Port Combo - Non-Design		3	UEP91		31.74										
<b>UNE Port/Loop Combination Rates (Design)</b>																
	2-Wire VG Loop/2-Wire Voice Grade Port (Centrex) Port Combo - Design		1	UEP91		13.82										
	2-Wire VG Loop/2-Wire Voice Grade Port (Centrex)Port Combo - Design		2	UEP91		18.60										
	2-Wire VG Loop/2-Wire Voice Grade Port (Centrex)Port Combo - Design		3	UEP91		34.37										
<b>UNE Loop Rate</b>																
	2-Wire Voice Grade Loop (SL 1) - Zone 1		1	UEP91	UECS1	9.64						7.86				
	2-Wire Voice Grade Loop (SL 1) - Zone 2		2	UEP91	UECS1	14.37						7.86				
	2-Wire Voice Grade Loop (SL 1) - Zone 3		3	UEP91	UECS1	30.59						7.86				
	2-Wire Voice Grade Loop (SL 2) - Zone 1		1	UEP91	UECS2	12.67						7.86				
	2-Wire Voice Grade Loop (SL 2) - Zone 2		2	UEP91	UECS2	17.45						7.86				
	2-Wire Voice Grade Loop (SL 2) - Zone 3		3	UEP91	UECS2	33.22						7.86				
<b>UNE Ports</b>																
<b>All States (Except North Carolina and Sout Carolina)</b>																
	2-Wire Voice Grade Port (Centrex ) Basic Local Area			UEP91	UEPYA	1.15	21.29	15.49	2.85	2.67		7.86				
	2-Wire Voice Grade Port (Centrex 800 termination)Basic Local Area			UEP91	UEPYB	1.15	21.29	15.49	2.85	2.67		7.86				
	2-Wire Voice Grade Port (Centrex with Caller ID)1Basic Local Area			UEP91	UEPYH	1.15	21.29	15.49	2.85	2.67		7.86				
	2-Wire Voice Grade Port (Centrex from diff Serving Wire Center)2 Basic Local Area			UEP91	UEPYM	1.15	21.29	15.49	2.85	2.67		7.86				
	2-Wire Voice Grade Port, Diff Serving Wire Center - 800 Service Term - Basic Local Area			UEP91	UEPYZ	1.15	21.29	15.49	2.85	2.67		7.86				
	2-Wire Voice Grade Port terminated in on Megalink or equivalent - Basic Local Area			UEP91	UEPY9	1.15	21.29	15.49	2.85	2.67		7.86				
	2-Wire Voice Grade Port Terminated on 800 Service Term - Basic Local Area			UEP91	UEPY2	1.15	21.29	15.49	2.85	2.67		7.86				
<b>AL, KY, LA, MS, &amp; TN Only</b>																
	2-Wire Voice Grade Port (Centrex )			UEP91	UEPQA	1.15	21.29	15.49	2.85	2.67		7.86				
	2-Wire Voice Grade Port (Centrex 800 termination)			UEP91	UEPQB	1.15	21.29	15.49	2.85	2.67		7.86				
	2-Wire Voice Grade Port (Centrex with Caller ID)1			UEP91	UEPQH	1.15	21.29	15.49	2.85	2.67		7.86				
	2-Wire Voice Grade Port (Centrex from diff Serving Wire Center)2			UEP91	UEPQM	1.15	21.29	15.49	2.85	2.67		7.86				
	2-Wire Voice Grade Port, Diff Serving Wire Center - 800 Service Term			UEP91	UEPQZ	1.15	21.29	15.49	2.85	2.67		7.86				
	2-Wire Voice Grade Port terminated in on Megalink or equivalent			UEP91	UEPQ9	1.15	21.29	15.49	2.85	2.67		7.86				
	2-Wire Voice Grade Port Terminated on 800 Service Term			UEP91	UEPQ2	1.15	21.29	15.49	2.85	2.67		7.86				
<b>Local Switching</b>																
	Centrex Intercom Funtionality, per port			UEP91	URECS	0.8873						7.86				
<b>Local Number Portability</b>																
	Local Number Portability (1 per port)			UEP91	LNPC	0.35										
<b>Features</b>																
	All Standard Features Offered, per port			UEP91	UEPVF	0.00						7.86				
	All Select Features Offered, per port			UEP91	UEPVS	0.00	405.66					7.86				
	All Centrex Control Features Offered, per port			UEP91	UEPVC	0.00						7.86				
<b>NARS</b>																
	Unbundled Network Access Register - Combination			UEP91	UARCX	0.00	0.00	0.00				7.86				
	Unbundled Network Access Register - Indial			UEP91	UARIX	0.00	0.00	0.00				7.86				
	Unbundled Network Access Register - Outdial			UEP91	UARO	0.00	0.00	0.00				7.86				
<b>Miscellaneous Terminations</b>																

UNBUNDLED NETWORK ELEMENTS - Kentucky										Attachment: 2		Exhibit: B	
CATEGORY	RATE ELEMENTS	Interim	Zone	BCS	USOC	RATES (\$)	Svc Order Submitted Elec per LSR	Svc Order Submitted Manually per LSR	Incremental Charge - Manual Svc Order vs. Electronic-1st	Incremental Charge - Manual Svc Order vs. Electronic-Add'l	Incremental Charge - Manual Svc Order vs. Electronic-Disc 1st	Incremental Charge - Manual Svc Order vs. Electronic-Disc Add'l	
													Rec
	<b>2-Wire Trunk Side</b>												
	Trunk Side Terminations, each			UEP91	CENA6	10.51			92.18	15.82	52.16	5.30	7.86
	<b>Interoffice Channel Mileage - 2-Wire</b>												
	Interoffice Channel Facilities Termination - Voice Grade			UEP91	M1GBC	29.11							7.86
	Interoffice Channel mileage, per mile or fraction of mile			UEP91	M1GBM	0.01							7.86
	<b>Feature Activations (DS0) Centrex Loops on Channelized DS1 Service</b>												
	<b>D4 Channel Bank Feature Activations</b>												
	Feature Activation on D-4 Channel Bank Centrex Loop Slot			UEP91	1PQWS	0.62							7.86
	Feature Activation on D-4 Channel Bank FX line Side Loop Slot			UEP91	1PQW6	0.62							7.86
	Feature Activation on D-4 Channel Bank FX Trunk Side Loop Slot			UEP91	1PQW7	0.62							7.86
	Feature Activation on D-4 Channel Bank Centrex Loop Slot - Different Wire Center			UEP91	1PQWP	0.62							7.86
	Feature Activation on D-4 Channel Bank Private Line Loop Slot			UEP91	1PQWV	0.62							7.86
	Feature Activation on D-4 Channel Bank Tjje Line/Trunk Loop Slot			UEP91	1PQWQ	0.62							7.86
	Feature Activation on D-4 Channel Bank WATS Loop Slot			UEP91	1PQWA	0.62							7.86
	<b>Non-Recurring Charges (NRC) Associated with UNE-P Centrex</b>												
	Conversion - Currently Combined Switch-As-Is with allowed changes, per port			UEP91	USAC2				0.102	0.102			7.86
	Conversion of Existing Centrex Common Block			UEP91	USACN				18.95	8.32			
	New Centrex Standard Common Block			UEP91	M1ACS	0.00			669.80	78.32	111.05	13.27	7.86
	New Centrex Customized Common Block			UEP91	M1ACC	0.00			669.80	78.32	111.05	13.27	7.86
	Secondary Block, per Block			UEP91	M2CC1	0.00			78.32	78.32	13.27	13.27	7.86
	NAR Establishment Charge, Per Occasion			UEP91	URECA	0.00			72.75				7.86
	<b>UNE-P CENTREX - 5ESS (Valid in All States)</b>												
	<b>2-Wire VG Loop/2-Wire Voice Grade Port (Centrex) Combo</b>												
	<b>UNE Port/Loop Combination Rates (Non-Design)</b>												
	2-Wire VG Loop/2-Wire Voice Grade Port (Centrex) Port Combo - Non-Design		1	UEP95		10.79							
	2-Wire VG Loop/2-Wire Voice Grade Port (Centrex)Port Combo - Non-Design		2	UEP95		15.52							
	2-Wire VG Loop/2-Wire Voice Grade Port (Centrex)Port Combo - Non-Design		3	UEP95		31.74							
	<b>UNE Port/Loop Combination Rates (Design)</b>												
	2-Wire VG Loop/2-Wire Voice Grade Port (Centrex) Port Combo - Design		1	UEP95		13.82							
	2-Wire VG Loop/2-Wire Voice Grade Port (Centrex)Port Combo - Design		2	UEP95		18.60							
	2-Wire VG Loop/2-Wire Voice Grade Port (Centrex)Port Combo - Design		3	UEP95		34.37							
	<b>UNE Loop Rate</b>												
	2-Wire Voice Grade Loop (SL 1) - Zone 1		1	UEP95	UECS1	9.64							7.86
	2-Wire Voice Grade Loop (SL 1) - Zone 2		2	UEP95	UECS1	14.37							7.86
	2-Wire Voice Grade Loop (SL 1) - Zone 3		3	UEP95	UECS1	30.59							7.86
	2-Wire Voice Grade Loop (SL 2) - Zone 1		1	UEP95	UECS2	12.67							7.86
	2-Wire Voice Grade Loop (SL 2) - Zone 2		2	UEP95	UECS2	17.45							7.86
	2-Wire Voice Grade Loop (SL 2) - Zone 3		3	UEP95	UECS2	33.22							7.86
	<b>UNE Port Rate</b>												
	<b>All States</b>												
	2-Wire Voice Grade Port (Centrex ) Basic Local Area			UEP95	UEPYA	1.15			21.29	15.49	2.85	2.67	7.86
	2-Wire Voice Grade Port (Centrex 800 termination)			UEP95	UEPYB	1.15			21.29	15.49	2.85	2.67	7.86
	2-Wire Voice Grade Port (Centrex with Caller ID)1Basic Local Area			UEP95	UEPYH	1.15			21.29	15.49	2.85	2.67	7.86
	2-Wire Voice Grade Port (Centrex from diff Serving Wire Center)2 Basic Local Area			UEP95	UEPYM	1.15			21.29	15.49	2.85	2.67	7.86

**UNBUNDLED NETWORK ELEMENTS - Kentucky**

CATEGORY	RATE ELEMENTS	Interim	Zone	BCS	USOC	RATES (\$)	Svc Order Submitted Elec per LSR	Svc Order Submitted Manually per LSR	Attachment: 2		Exhibit: B							
									Incremental Charge - Manual Svc Order vs. Electronic-1st	Incremental Charge - Manual Svc Order vs. Electronic-Add'l	Incremental Charge - Manual Svc Order vs. Electronic-Disc 1st	Incremental Charge - Manual Svc Order vs. Electronic-Disc Add'l						
									Rec	Nonrecurring		Nonrecurring Disconnect		OSS Rates(\$)				
								First	Add'l	First	Add'l	SOMEc	SOMAN	SOMAN	SOMAN	SOMAN	SOMAN	
	2-Wire Voice Grade Port, Diff Serving Wire Center - 800 Service Term - Basic Local Area			UEP95	UEPYZ	1.15		21.29	15.49	2.85	2.67		7.86					
	2-Wire Voice Grade Port terminated in on Megalink or equivalent - Basic Local Area			UEP95	UEPY9	1.15		21.29	15.49	2.85	2.67		7.86					
	2-Wire Voice Grade Port Terminated on 800 Service Term - Basic Local Area			UEP95	UEPY2	1.15		21.29	15.49	2.85	2.67		7.86					
<b>AL, KY, LA, MS, SC, &amp; TN Only</b>																		
	2-Wire Voice Grade Port (Centrex )			UEP95	UEPQA	1.15		21.29	15.49	2.85	2.67		7.86					
	2-Wire Voice Grade Port (Centrex 800 termination)			UEP95	UEPQB	1.15		21.29	15.49	2.85	2.67		7.86					
	2-Wire Voice Grade Port (Centrex with Caller ID)1			UEP95	UEPQH	1.15		21.29	15.49	2.85	2.67		7.86					
	2-Wire Voice Grade Port (Centrex from diff Serving Wire Center)2			UEP95	UEPQM	1.15		21.29	15.49	2.85	2.67		7.86					
	2-Wire Voice Grade Port, Diff Serving Wire Center - 800 Service Term			UEP95	UEPQZ	1.15		21.29	15.49	2.85	2.67		7.86					
	2-Wire Voice Grade Port terminated in on Megalink or equivalent			UEP95	UEPQ9	1.15		21.29	15.49	2.85	2.67		7.86					
	2-Wire Voice Grade Port Terminated on 800 Service Term			UEP95	UEPQ2	1.15		21.29	15.49	2.85	2.67		7.86					
<b>Local Switching</b>																		
	Centrex Intercom Funtionalty, per port			UEP95	URECS	0.8873							7.86					
<b>Local Number Portability</b>																		
	Local Number Portability (1 per port)			UEP95	LNPC	0.35												
<b>Features</b>																		
	All Standard Features Offered, per port			UEP95	UEPVF	0.00							7.86					
	All Select Features Offered, per port			UEP95	UEPVS	0.00	405.66						7.86					
	All Centrex Control Features Offered, per port			UEP95	UEPVC	0.00							7.86					
<b>NARS</b>																		
	Unbundled Network Access Register - Combination			UEP95	UARCX	0.00	0.00	0.00	0.00				7.86					
	Unbundled Network Access Register - Indial			UEP95	UAR1X	0.00	0.00	0.00	0.00				7.86					
	Unbundled Network Access Register - Outdial			UEP95	UAROX	0.00	0.00	0.00	0.00				7.86					
<b>Miscellaneous Terminations</b>																		
<b>2-Wire Trunk Side</b>																		
	Trunk Side Terminations, each			UEP95	CEND6	10.51		92.18	15.82	52.16	5.30		7.86					
<b>4-Wire Digital (1.544 Megabits)</b>																		
	DS1 Circuit Terminations, each			UEP95	M1HD1	74.77		164.86	77.74	60.69	3.86		7.86					
	DS0 Channels Activated, each			UEP95	M1HDO	0.00		15.09					7.86					
<b>Interoffice Channel Mileage - 2-Wire</b>																		
	Interoffice Channel Facilities Termination			UEP95	M1GBC	29.11							7.86					
	Interoffice Channel mileage, per mile or fraction of mile			UEP95	M1GBM	0.01							7.86					
<b>Feature Activations (DS0) Centrex Loops on Channelized DS1 Service</b>																		
<b>D4 Channel Bank Feature Activations</b>																		
	Feature Activation on D-4 Channel Bank Centrex Loop Slot			UEP95	1PQWS	0.62							7.86					
	Feature Activation on D-4 Channel Bank FX line Side Loop Slot			UEP95	1PQW6	0.62							7.86					
	Feature Activation on D-4 Channel Bank FX Trunk Side Loop Slot			UEP95	1PQW7	0.62							7.86					
	Feature Activation on D-4 Channel Bank Centrex Loop Slot - Different Wire Center			UEP95	1PQWP	0.62							7.86					
	Feature Activation on D-4 Channel Bank Private Line Loop Slot			UEP95	1PQWV	0.62							7.86					
	Feature Activation on D-4 Channel Bank Tjje Line/Trunk Loop Slot			UEP95	1PQWQ	0.62							7.86					
	Feature Activation on D-4 Channel Bank WATS Loop Slot			UEP95	1PQWA	0.62							7.86					
<b>Non-Recurring Charges (NRC) Associated with UNE-P Centrex</b>																		
	NRC Conversion Currently Combined Switch-As-Is with allowed changes, per port			UEP95	USAC2			0.102	0.102				7.86					
	Conversion of Existing Centrex Common Block, each			UEP95	USACN			18.95	8.32				7.86					
	New Centrex Standard Common Block			UEP95	M1ACS	0.00	669.80	78.32	111.05	13.27			7.86					
	New Centrex Customized Common Block			UEP95	M1ACC	0.00	669.80	78.32	111.05	13.27			7.86					
	NAR Establishment Charge, Per Occasion			UEP95	URECA	0.00		72.75					7.86					

**UNBUNDLED NETWORK ELEMENTS - Kentucky**

CATEGORY	RATE ELEMENTS	Interim	Zone	BCS	USOC	RATES (\$)	Svc Order Submitted Elec per LSR	Svc Order Submitted Manually per LSR	Attachment: 2		Exhibit: B			
									Incremental Charge - Manual Svc Order vs. Electronic-1st	Incremental Charge - Manual Svc Order vs. Electronic-Add'l	Incremental Charge - Manual Svc Order vs. Electronic-Disc 1st	Incremental Charge - Manual Svc Order vs. Electronic-Disc Add'l		
									Rec	Nonrecurring		Nonrecurring Disconnect		OSS Rates(\$)
								SOME C	SOMAN	SOMAN	SOMAN	SOMAN	SOMAN	
<b>UNE-P CENTREX - DMS100 (Valid in All States)</b>														
<b>2-Wire VG Loop/2-Wire Voice Grade Port (Centrex) Combo</b>														
<b>UNE Port/Loop Combination Rates (Non-Design)</b>														
	2-Wire VG Loop/2-Wire Voice Grade Port (Centrex) Port Combo - Non-Design		1	UEP9D		10.79								
	2-Wire VG Loop/2-Wire Voice Grade Port (Centrex)Port Combo - Non-Design		2	UEP9D		15.52								
	2-Wire VG Loop/2-Wire Voice Grade Port (Centrex)Port Combo - Non-Design		3	UEP9D		31.74								
<b>UNE Port/Loop Combination Rates (Design)</b>														
	2-Wire VG Loop/2-Wire Voice Grade Port (Centrex) Port Combo - Design		1	UEP9D		13.82								
	2-Wire VG Loop/2-Wire Voice Grade Port (Centrex)Port Combo - Design		2	UEP9D		18.60								
	2-Wire VG Loop/2-Wire Voice Grade Port (Centrex)Port Combo - Design		3	UEP9D		34.37								
<b>UNE Loop Rate</b>														
	2-Wire Voice Grade Loop (SL 1) - Zone 1		1	UEP9D	UECS1	9.64					7.86			
	2-Wire Voice Grade Loop (SL 1) - Zone 2		2	UEP9D	UECS1	14.37					7.86			
	2-Wire Voice Grade Loop (SL 1) - Zone 3		3	UEP9D	UECS1	30.59					7.86			
	2-Wire Voice Grade Loop (SL 2) - Zone 1		1	UEP9D	UECS2	12.67					7.86			
	2-Wire Voice Grade Loop (SL 2) - Zone 2		2	UEP9D	UECS2	17.45					7.86			
	2-Wire Voice Grade Loop (SL 2) - Zone 3		3	UEP9D	UECS2	33.22					7.86			
<b>UNE Port Rate</b>														
<b>ALL STATES</b>														
	2-Wire Voice Grade Port (Centrex ) Basic Local Area			UEP9D	UEPYA	1.15	21.29	15.49	2.85	2.67		7.86		
	2-Wire Voice Grade Port (Centrex 800 termination)Basic Local Area			UEP9D	UEPYB	1.15	21.29	15.49	2.85	2.67		7.86		
	2-Wire Voice Grade Port (Centrex / EBS-PSET)3Basic Local Area			UEP9D	UEPYC	1.15	21.29	15.49	2.85	2.67		7.86		
	2-Wire Voice Grade Port (Centrex / EBS-M5009)3Basic Local Area			UEP9D	UEPYD	1.15	21.29	15.49	2.85	2.67		7.86		
	2-Wire Voice Grade Port (Centrex / EBS-M5209))3 Basic Local Area			UEP9D	UEPYE	1.15	21.29	15.49	2.85	2.67		7.86		
	2-Wire Voice Grade Port (Centrex / EBS-M5112))3 Basic Local Area			UEP9D	UEPYF	1.15	21.29	15.49	2.85	2.67		7.86		
	2-Wire Voice Grade Port (Centrex / EBS-M5312))3Basic Local Area			UEP9D	UEPYG	1.15	21.29	15.49	2.85	2.67		7.86		
	2-Wire Voice Grade Port (Centrex / EBS-M5008))3 Basic Local Area			UEP9D	UEPYT	1.15	21.29	15.49	2.85	2.67		7.86		
	2-Wire Voice Grade Port (Centrex / EBS-M5208))3 Basic Local Area			UEP9D	UEPYU	1.15	21.29	15.49	2.85	2.67		7.86		
	2-Wire Voice Grade Port (Centrex / EBS-M5216))3 Basic Local Area			UEP9D	UEPYV	1.15	21.29	15.49	2.85	2.67		7.86		
	2-Wire Voice Grade Port (Centrex / EBS-M5316))3 Basic Local Area			UEP9D	UEPY3	1.15	21.29	15.49	2.85	2.67		7.86		
	2-Wire Voice Grade Port (Centrex with Caller ID) Basic Local Area			UEP9D	UEPYH	1.15	21.29	15.49	2.85	2.67		7.86		
	2-Wire Voice Grade Port (Centrex/Caller ID/Msg Wtg Lamp Indication))3 Basic Local Area			UEP9D	UEPYW	1.15	21.29	15.49	2.85	2.67		7.86		
	2-Wire Voice Grade Port (Centrex/Msg Wtg Lamp Indication))3 Basic Local Area			UEP9D	UEPYJ	1.15	21.29	15.49	2.85	2.67		7.86		
	2-Wire Voice Grade Port (Centrex from diff Serving Wire Center) 2 Basic Local Area			UEP9D	UEPYM	1.15	21.29	15.49	2.85	2.67		7.86		
	2-Wire Voice Grade Port (Centrex/differ SWC /EBS-PSET)2, 3 Basic Local Area			UEP9D	UEPYO	1.15	21.29	15.49	2.85	2.67		7.86		
	2-Wire Voice Grade Port (Centrex/differ SWC /EBS-M5009)2, 3 Basic Local Area			UEP9D	UEPYP	1.15	21.29	15.49	2.85	2.67		7.86		

UNBUNDLED NETWORK ELEMENTS - Kentucky									Attachment: 2		Exhibit: B					
CATEGORY	RATE ELEMENTS	Interim	Zone	BCS	USOC	RATES (\$)	Svc Order Submitted Elec per LSR	Svc Order Submitted Manually per LSR	Incremental Charge - Manual Svc Order vs. Electronic-1st	Incremental Charge - Manual Svc Order vs. Electronic-Add'l	Incremental Charge - Manual Svc Order vs. Electronic-Disc 1st	Incremental Charge - Manual Svc Order vs. Electronic-Disc Add'l				
													Rec	Nonrecurring		Nonrecurring Disconnect
							First	Add'l	First	Add'l	SOMEC	SOMAN	SOMAN	SOMAN	SOMAN	SOMAN
	2-Wire Voice Grade Port (Centrex/differ SWC /EBS-5209)2, 3 Basic Local Area			UEP9D	UEPYQ	1.15	21.29	15.49	2.85	2.67		7.86				
	2-Wire Voice Grade Port (Centrex/differ SWC /EBS-M5112)2, 3 Basic Local Area			UEP9D	UEPYR	1.15	21.29	15.49	2.85	2.67		7.86				
	2-Wire Voice Grade Port (Centrex/differ SWC /EBS-M5312)2, 3 Basic Local Area			UEP9D	UEPYS	1.15	21.29	15.49	2.85	2.67		7.86				
	2-Wire Voice Grade Port (Centrex/differ SWC /EBS-M5008)2, 3 Basic Local Area			UEP9D	UEPY4	1.15	21.29	15.49	2.85	2.67		7.86				
	2-Wire Voice Grade Port (Centrex/differ SWC /EBS-M5208)2, 3 Basic Local Area			UEP9D	UEPY5	1.15	21.29	15.49	2.85	2.67		7.86				
	2-Wire Voice Grade Port (Centrex/differ SWC /EBS-M5216)2, 3 Basic Local Area			UEP9D	UEPY6	1.15	21.29	15.49	2.85	2.67		7.86				
	2-Wire Voice Grade Port (Centrex/differ SWC /EBS-M5316)2, 3 Basic Local Area			UEP9D	UEPY7	1.15	21.29	15.49	2.85	2.67		7.86				
	2-Wire Voice Grade Port, Diff Serving Wire Center - 800 Service Term			UEP9D	UEPYZ	1.15	21.29	15.49	2.85	2.67		7.86				
	2-Wire Voice Grade Port terminated in on Megalink or equivalent Basic Local Area			UEP9D	UEPY9	1.15	21.29	15.49	2.85	2.67		7.86				
	2-Wire Voice Grade Port Terminated on 800 Service Term Basic Local Area			UEP9D	UEPY2	1.15	21.29	15.49	2.85	2.67		7.86				
	<b>AL, KY, LA, MS, SC, &amp; TN Only</b>															
	2-Wire Voice Grade Port (Centrex)			UEP9D	UEPQA	1.15	21.29	15.49	2.85	2.67		7.86				
	2-Wire Voice Grade Port (Centrex 800 termination)			UEP9D	UEPQB	1.15	21.29	15.49	2.85	2.67		7.86				
	2-Wire Voice Grade Port (Centrex / EBS-PSET)3			UEP9D	UEPQC	1.15	21.29	15.49	2.85	2.67		7.86				
	2-Wire Voice Grade Port (Centrex / EBS-M5009)3			UEP9D	UEPQD	1.15	21.29	15.49	2.85	2.67		7.86				
	2-Wire Voice Grade Port (Centrex / EBS-M5209)3			UEP9D	UEPQE	1.15	21.29	15.49	2.85	2.67		7.86				
	2-Wire Voice Grade Port (Centrex / EBS-M5112)3			UEP9D	UEPQF	1.15	21.29	15.49	2.85	2.67		7.86				
	2-Wire Voice Grade Port (Centrex / EBS-M5312)3			UEP9D	UEPQG	1.15	21.29	15.49	2.85	2.67		7.86				
	2-Wire Voice Grade Port (Centrex / EBS-M5008)3			UEP9D	UEPQT	1.15	21.29	15.49	2.85	2.67		7.86				
	2-Wire Voice Grade Port (Centrex / EBS-M5208)3			UEP9D	UEPQU	1.15	21.29	15.49	2.85	2.67		7.86				
	2-Wire Voice Grade Port (Centrex / EBS-M5216)3			UEP9D	UEPQV	1.15	21.29	15.49	2.85	2.67		7.86				
	2-Wire Voice Grade Port (Centrex / EBS-M5316)3			UEP9D	UEPQ3	1.15	21.29	15.49	2.85	2.67		7.86				
	2-Wire Voice Grade Port (Centrex with Caller ID)			UEP9D	UEPQH	1.15	21.29	15.49	2.85	2.67		7.86				
	2-Wire Voice Grade Port (Centrex/Caller ID/Msg Wtg Lamp Indication)3			UEP9D	UEPQW	1.15	21.29	15.49	2.85	2.67		7.86				
	2-Wire Voice Grade Port (Centrex/Msg Wtg Lamp Indication)3			UEP9D	UEPQJ	1.15	21.29	15.49	2.85	2.67		7.86				
	2-Wire Voice Grade Port (Centrex from diff Serving Wire Center) 2			UEP9D	UEPQM	1.15	21.29	15.49	2.85	2.67		7.86				
	2-Wire Voice Grade Port (Centrex/differ SWC /EBS-PSET)2, 3			UEP9D	UEPQO	1.15	21.29	15.49	2.85	2.67		7.86				
	2-Wire Voice Grade Port (Centrex/differ SWC /EBS-M5009)2, 3			UEP9D	UEPQP	1.15	21.29	15.49	2.85	2.67		7.86				
	2-Wire Voice Grade Port (Centrex/differ SWC /EBS-5209)2, 3			UEP9D	UEPQQ	1.15	21.29	15.49	2.85	2.67		7.86				
	2-Wire Voice Grade Port (Centrex/differ SWC /EBS-M5112)2, 3			UEP9D	UEPQR	1.15	21.29	15.49	2.85	2.67		7.86				
	2-Wire Voice Grade Port (Centrex/differ SWC /EBS-M5312)2, 3			UEP9D	UEPQS	1.15	21.29	15.49	2.85	2.67		7.86				
	2-Wire Voice Grade Port (Centrex/differ SWC /EBS-M5008)2, 3			UEP9D	UEPQ4	1.15	21.29	15.49	2.85	2.67		7.86				
	2-Wire Voice Grade Port (Centrex/differ SWC /EBS-M5208)2, 3			UEP9D	UEPQ5	1.15	21.29	15.49	2.85	2.67		7.86				
	2-Wire Voice Grade Port (Centrex/differ SWC /EBS-M5216)2, 3			UEP9D	UEPQ6	1.15	21.29	15.49	2.85	2.67		7.86				
	2-Wire Voice Grade Port (Centrex/differ SWC /EBS-M5316)2, 3			UEP9D	UEPQ7	1.15	21.29	15.49	2.85	2.67		7.86				
	2-Wire Voice Grade Port, Diff Serving Wire Center - 800 Service Term			UEP9D	UEPQZ	1.15	21.29	15.49	2.85	2.67		7.86				
	2-Wire Voice Grade Port terminated in on Megalink or equivalent			UEP9D	UEPQ9	1.15	21.29	15.49	2.85	2.67		7.86				
	2-Wire Voice Grade Port Terminated on 800 Service Term			UEP9D	UEPQ2	1.15	21.29	15.49	2.85	2.67		7.86				

UNBUNDLED NETWORK ELEMENTS - Kentucky										Attachment: 2		Exhibit: B			
CATEGORY	RATE ELEMENTS	Interim	Zone	BCS	USOC	RATES (\$)				Svc Order Submitted Elec per LSR	Svc Order Submitted Manually per LSR	Incremental Charge - Manual Svc Order vs. Electronic-1st	Incremental Charge - Manual Svc Order vs. Electronic-Add'l	Incremental Charge - Manual Svc Order vs. Electronic-Disc 1st	Incremental Charge - Manual Svc Order vs. Electronic-Disc Add'l
						Rec	Nonrecurring		Nonrecurring Disconnect						
							First	Add'l	First	Add'l	SOMEc	SOMAN	SOMAN	SOMAN	SOMAN
<b>Local Switching</b>															
	Centrex Intercom Functionality, per port			UEP9D	URECS	0.8873						7.86			
<b>Local Number Portability</b>															
	Local Number Portability (1 per port)			UEP9D	LNPCC	0.35									
<b>Features</b>															
	All Standard Features Offered, per port			UEP9D	UEPVF	0.00						7.86			
	All Select Features Offered, per port			UEP9D	UEPVS	0.00	405.66					7.86			
	All Centrex Control Features Offered, per port			UEP9D	UEPVC	0.00						7.86			
<b>NARS</b>															
	Unbundled Network Access Register - Combination			UEP9D	UARCX	0.00	0.00	0.00				7.86			
	Unbundled Network Access Register - Inward			UEP9D	UAR1X	0.00	0.00	0.00				7.86			
	Unbundled Network Access Register - Outdial			UEP9D	UAROx	0.00	0.00	0.00				7.86			
<b>Miscellaneous Terminations</b>															
<b>2-Wire Trunk Side</b>															
	Trunk Side Terminations, each			UEP9D	CEND6	10.51	92.18	15.82	52.16	5.30		7.86			
<b>4-Wire Digital (1.544 Megabits)</b>															
	DS1 Circuit Terminations, each			UEP9D	M1HD1	74.77	164.86	77.74	60.69	3.86		7.86			
	DS0 Channels Activated per Channel			UEP9D	M1HDO	0.00	15.09					7.86			
<b>Interoffice Channel Mileage - 2-Wire</b>															
	Interoffice Channel Facilities Termination			UEP9D	M1GBC	29.11						7.86			
	Interoffice Channel mileage, per mile or fraction of mile			UEP9D	M1GBM	0.01						7.86			
<b>Feature Activations (DS0) Centrex Loops on Channelized DS1 Service</b>															
<b>D4 Channel Bank Feature Activations</b>															
	Feature Activation on D-4 Channel Bank Centrex Loop Slot			UEP9D	1PQWS	0.62						7.86			
	Feature Activation on D-4 Channel Bank FX line Side Loop Slot			UEP9D	1PQW6	0.62						7.86			
	Feature Activation on D-4 Channel Bank FX Trunk Side Loop Slot			UEP9D	1PQW7	0.62						7.86			
	Feature Activation on D-4 Channel Bank Centrex Loop Slot - Different Wire Center			UEP9D	1PQWP	0.62						7.86			
	Feature Activation on D-4 Channel Bank Private Line Loop Slot			UEP9D	1PQWV	0.62						7.86			
	Feature Activation on D-4 Channel Bank Tjje Line/Trunk Loop Slot			UEP9D	1PQWQ	0.62						7.86			
	Feature Activation on D-4 Channel Bank WATS Loop Slot			UEP9D	1PQWA	0.62						7.86			
<b>Non-Recurring Charges (NRC) Associated with UNE-P Centrex</b>															
	NRC Conversion Currently Combined Switch-As-Is with allowed changes, per port			UEP9D	USAC2		0.102	0.102				7.86			
	Conversion of existing Centrex Common Block, each			UEP9D	USACN		18.95	8.32				7.86			
	New Centrex Standard Common Block			UEP9D	M1ACS	0.00	669.80	78.32	111.05	13.27		7.86			
	New Centrex Customized Common Block			UEP9D	M1ACC	0.00	669.80	78.32	111.05	13.27		7.86			
	NAR Establishment Charge, Per Occasion			UEP9D	URECA	0.00	72.75					7.86			
<b>UNE-P CENTREX - EWSD (Valid in AL, FL, KY, LA, MS &amp; TN)</b>															
<b>2-Wire VG Loop/2-Wire Voice Grade Port (Centrex) Combo</b>															
<b>UNE Port/Loop Combination Rates (Non-Design)</b>															
	2-Wire VG Loop/2-Wire Voice Grade Port (Centrex) Port Combo - Non-Design		1	UEP9E		10.79									
	2-Wire VG Loop/2-Wire Voice Grade Port (Centrex)Port Combo - Non-Design		2	UEP9E		15.52									
	2-Wire VG Loop/2-Wire Voice Grade Port (Centrex)Port Combo - Non-Design		3	UEP9E		31.74									
<b>UNE Port/Loop Combination Rates (Design)</b>															
	2-Wire VG Loop/2-Wire Voice Grade Port (Centrex) Port Combo - Design		1	UEP9E		13.82									
	2-Wire VG Loop/2-Wire Voice Grade Port (Centrex)Port Combo - Design		2	UEP9E		18.60									
	2-Wire VG Loop/2-Wire Voice Grade Port (Centrex)Port Combo - Design		3	UEP9E		34.37									
<b>UNE Loop Rate</b>															



UNBUNDLED NETWORK ELEMENTS - Kentucky										Attachment: 2		Exhibit: B			
CATEGORY	RATE ELEMENTS	Interim	Zone	BCS	USOC	RATES (\$)				Svc Order Submitted Elec per LSR	Svc Order Submitted Manually per LSR	Incremental Charge - Manual Svc Order vs. Electronic-1st	Incremental Charge - Manual Svc Order vs. Electronic-Add'l	Incremental Charge - Manual Svc Order vs. Electronic-Disc 1st	Incremental Charge - Manual Svc Order vs. Electronic-Disc Add'l
						Rec	Nonrecurring		Nonrecurring Disconnect						
							First	Add'l	First	Add'l	SOMEc	SOMAN	SOMAN	SOMAN	SOMAN
	2-Wire Voice Grade Loop (SL 1) - Zone 1		1	UEP9E	UECS1	9.64						7.86			
	2-Wire Voice Grade Loop (SL 1) - Zone 2		2	UEP9E	UECS1	14.37						7.86			
	2-Wire Voice Grade Loop (SL 1) - Zone 3		3	UEP9E	UECS1	30.59						7.86			
	2-Wire Voice Grade Loop (SL 2) - Zone 1		1	UEP9E	UECS2	12.67						7.86			
	2-Wire Voice Grade Loop (SL 2) - Zone 2		2	UEP9E	UECS2	17.45						7.86			
	2-Wire Voice Grade Loop (SL 2) - Zone 3		3	UEP9E	UECS2	33.22						7.86			
<b>UNE Port Rate</b>															
<b>AL, FL, KY, LA, MS, &amp; TN only</b>															
	2-Wire Voice Grade Port (Centrex ) Basic Local Area			UEP9E	UEPYA	1.15	21.29	15.49	2.85	2.67		7.86			
	2-Wire Voice Grade Port (Centrex 800 termination)Basic Local Area			UEP9E	UEPYB	1.15	21.29	15.49	2.85	2.67		7.86			
	2-Wire Voice Grade Port (Centrex with Caller ID)1Basic Local Area			UEP9E	UEPYH	1.15	21.29	15.49	2.85	2.67		7.86			
	2-Wire Voice Grade Port (Centrex from diff Serving Wire Center)2 Basic Local Area			UEP9E	UEPYM	1.15	21.29	15.49	2.85	2.67		7.86			
	2-Wire Voice Grade Port, Diff Serving Wire Center - 800 Service Term - Basic Local Area			UEP9E	UEPYZ	1.15	21.29	15.49	2.85	2.67		7.86			
	2-Wire Voice Grade Port terminated in on Megalink or equivalent - Basic Local Area			UEP9E	UEPY9	1.15	21.29	15.49	2.85	2.67		7.86			
	2-Wire Voice Grade Port Terminated on 800 Service Term - Basic Local Area			UEP9E	UEPY2	1.15	21.29	15.49	2.85	2.67		7.86			
<b>AL, KY, LA, MS, &amp; TN Only</b>															
	2-Wire Voice Grade Port (Centrex )			UEP9E	UEPQA	1.15	21.29	15.49	2.85	2.67		7.86			
	2-Wire Voice Grade Port (Centrex 800 termination)			UEP9E	UEPQB	1.15	21.29	15.49	2.85	2.67		7.86			
	2-Wire Voice Grade Port (Centrex with Caller ID)1			UEP9E	UEPQH	1.15	21.29	15.49	2.85	2.67		7.86			
	2-Wire Voice Grade Port (Centrex from diff Serving Wire Center)2			UEP9E	UEPQM	1.15	21.29	15.49	2.85	2.67		7.86			
	2-Wire Voice Grade Port, Diff Serving Wire Center - 800 Service Term			UEP9E	UEPQZ	1.15	21.29	15.49	2.85	2.67		7.86			
	2-Wire Voice Grade Port terminated in on Megalink or equivalent			UEP9E	UEPQ9	1.15	21.29	15.49	2.85	2.67		7.86			
	2-Wire Voice Grade Port Terminated on 800 Service Term			UEP9E	UEPQ2	1.15	21.29	15.49	2.85	2.67		7.86			
<b>Local Switching</b>															
	Centrex Intercom Funtionality, per port			UEP9E	URECS	0.8873						7.86			
<b>Local Number Portability</b>															
	Local Number Portability (1 per port)			UEP9E	LNPCc	0.35						7.86			
<b>Features</b>															
	All Standard Features Offered, per port			UEP9E	UEPVF	0.00						7.86			
	All Select Features Offered, per port			UEP9E	UEPVS	0.00	405.66					7.86			
	All Centrex Control Features Offered, per port			UEP9E	UEPVC	0.00						7.86			
<b>NARS</b>															
	Unbundled Network Access Register - Combination			UEP9E	UARCX	0.00	0.00	0.00							
	Unbundled Network Access Register - Indial			UEP9E	UAR1X	0.00	0.00	0.00							
	Unbundled Network Access Register - Outdial			UEP9E	UAROx	0.00	0.00	0.00							
<b>Miscellaneous Terminations</b>															
<b>2-Wire Trunk Side</b>															
	Trunk Side Terminations, each			UEP9E	CEND6	10.51	92.18	15.82	52.16	5.30		7.86			
<b>4-Wire Digital (1.544 Megabits)</b>															
	DS1 Circuit Terminations, each			UEP9E	M1HD1	74.77	164.86	77.74	60.69	3.86		7.86			
	DS0 Channel Activated Per Channel			UEP9E	M1HDO	0.00	15.09					7.86			
<b>Interoffice Channel Mileage - 2-Wire</b>															
	Interoffice Channel Facilities Termination			UEP9E	M1GBC	29.11						7.86			
	Interoffice Channel mileage, per mile or fraction of mile			UEP9E	M1GBM	0.01						7.86			
<b>Feature Activations (DS0) Centrex Loops on Channelized DS1 Service</b>															
<b>D4 Channel Bank Feature Activations</b>															
	Feature Activation on D-4 Channel Bank Centrex Loop Slot			UEP9E	1PQWS	0.62						7.86			
	Feature Activation on D-4 Channel Bank FX line Side Loop Slot			UEP9E	1PQW6	0.62						7.86			

UNBUNDLED NETWORK ELEMENTS - Kentucky							Attachment: 2		Exhibit: B							
CATEGORY	RATE ELEMENTS	Interim	Zone	BCS	USOC	RATES (\$)	Svc Order Submitted Elec per LSR	Svc Order Submitted Manually per LSR	Incremental Charge - Manual Svc Order vs. Electronic-1st	Incremental Charge - Manual Svc Order vs. Electronic-Add'l	Incremental Charge - Manual Svc Order vs. Electronic-Disc 1st	Incremental Charge - Manual Svc Order vs. Electronic-Disc Add'l				
							Rec	Nonrecurring		Nonrecurring Disconnect		OSS Rates(\$)				
							First	Add'l	First	Add'l	SOMEC	SOMAN	SOMAN	SOMAN	SOMAN	SOMAN
	Feature Activation on D-4 Channel Bank FX Trunk Side Loop Slot			UEP9E	1PQW7	0.62						7.86				
	Feature Activation on D-4 Channel Bank Centrex Loop Slot - Different Wire Center			UEP9E	1PQWP	0.62						7.86				
	Feature Activation on D-4 Channel Bank Private Line Loop Slot			UEP9E	1PQWV	0.62						7.86				
	Feature Activation on D-4 Channel Bank Tjje Line/Trunk Loop Slot			UEP9E	1PQWQ	0.62						7.86				
	Feature Activation on D-4 Channel Bank WATS Loop Slot			UEP9E	1PQWA	0.62						7.86				
	<b>Non-Recurring Charges (NRC) Associated with UNE-P Centrex</b>															
	NRC Conversion Currently Combined Switch-As-Is with allowed changes, per port			UEP9E	USAC2		0.102	0.102				7.86				
	Conversion of Existing Centrex Common Block, each			UEP9E	USACN		18.95	8.32								
	New Centrex Standard Common Block			UEP9E	M1ACS	0.00	669.80	78.32	111.05	13.27		7.86				
	New Centrex Customized Common Block			UEP9E	M1ACC	0.00	669.80	78.32	111.05	13.27		7.86				
	NAR Establishment Charge, Per Occasion			UEP9E	URECA	0.00	72.75					7.86				
	<b>UNE-P CENTREX - DCO - Valid in AL, KY, LA, MS, &amp; TN</b>															
	<b>2-Wire VG Loop/2-Wire Voice Grade Port (Centrex) Combo</b>															
	<b>UNE Port/Loop Combination Rates (Non-Design)</b>															
	2-Wire VG Loop/2-Wire Voice Grade Port (Centrex) Port Combo - Non-Design		1	UEP93		10.79										
	2-Wire VG Loop/2-Wire Voice Grade Port (Centrex)Port Combo - Non-Design		2	UEP93		15.52										
	2-Wire VG Loop/2-Wire Voice Grade Port (Centrex)Port Combo - Non-Design		3	UEP93		31.74										
	<b>UNE Port/Loop Combination Rates (Design)</b>															
	2-Wire VG Loop/2-Wire Voice Grade Port (Centrex) Port Combo - Design		1	UEP93		13.82										
	2-Wire VG Loop/2-Wire Voice Grade Port (Centrex)Port Combo - Design		2	UEP93		18.60										
	2-Wire VG Loop/2-Wire Voice Grade Port (Centrex)Port Combo - Design		3	UEP93		34.37										
	<b>UNE Loop Rate</b>															
	2-Wire Voice Grade Loop (SL 1) - Zone 1		1	UEP93	UECS1	9.64										
	2-Wire Voice Grade Loop (SL 1) - Zone 2		2	UEP93	UECS1	14.37										
	2-Wire Voice Grade Loop (SL 1) - Zone 3		3	UEP93	UECS1	30.59										
	2-Wire Voice Grade Loop (SL 2) - Zone 1		1	UEP93	UECS2	12.67										
	2-Wire Voice Grade Loop (SL 2) - Zone 2		2	UEP93	UECS2	17.45										
	2-Wire Voice Grade Loop (SL 2) - Zone 3		3	UEP93	UECS2	33.22										
	<b>UNE Port Rate</b>															
	<b>AL, KY, LA, MS, &amp; TN only</b>															
	2-Wire Voice Grade Port (Centrex ) Basic Local Area			UEP93	UEPYA	1.15	21.29	15.49	2.85	2.67		7.86				
	2-Wire Voice Grade Port (Centrex 800 termination)Basic Local Area			UEP93	UEPYB	1.15	21.29	15.49	2.85	2.67		7.86				
	2-Wire Voice Grade Port (Centrex with Caller ID)1Basic Local Area			UEP93	UEPYH	1.15	21.29	15.49	2.85	2.67		7.86				
	2-Wire Voice Grade Port (Centrex from diff Serving Wire Center)2 Basic Local Area			UEP93	UEPYM	1.15	21.29	15.49	2.85	2.67		7.86				
	2-Wire Voice Grade Port, Diff Serving Wire Center - 800 Service Term - Basic Local Area			UEP93	UEPYZ	1.15	21.29	15.49	2.85	2.67		7.86				
	2-Wire Voice Grade Port terminated in on Megalink or equivalent - Basic Local Area			UEP93	UEPY9	1.15	21.29	15.49	2.85	2.67		7.86				
	2-Wire Voice Grade Port Terminated on 800 Service Term - Basic Local Area			UEP93	UEPY2	1.15	21.29	15.49	2.85	2.67		7.86				
	2-Wire Voice Grade Port (Centrex )			UEP93	UEPQA	1.15	21.29	15.49	2.85	2.67		7.86				
	2-Wire Voice Grade Port (Centrex 800 termination)			UEP93	UEPQB	1.15	21.29	15.49	2.85	2.67		7.86				
	2-Wire Voice Grade Port (Centrex with Caller ID)1			UEP93	UEPQH	1.15	21.29	15.49	2.85	2.67		7.86				
	2-Wire Voice Grade Port (Centrex from diff Serving Wire Center)2			UEP93	UEPQM	1.15	21.29	15.49	2.85	2.67		7.86				

UNBUNDLED NETWORK ELEMENTS - Kentucky											Attachment: 2		Exhibit: B		
CATEGORY	RATE ELEMENTS	Interim	Zone	BCS	USOC	RATES (\$)	Svc Order Submitted Elec per LSR	Svc Order Submitted Manually per LSR	Incremental Charge - Manual Svc Order vs. Electronic-1st	Incremental Charge - Manual Svc Order vs. Electronic-Add'l	Incremental Charge - Manual Svc Order vs. Electronic-Disc 1st	Incremental Charge - Manual Svc Order vs. Electronic-Disc Add'l	OSS Rates(\$)		
													Rec	Nonrecurring First	Nonrecurring Add'l
	2-Wire Voice Grade Port, Diff Serving Wire Center - 800 Service Term			UEP93	UEPQZ	1.15									
	2-Wire Voice Grade Port terminated in on Megalink or equivalent			UEP93	UEPQ9	1.15									
	2-Wire Voice Grade Port Terminated on 800 Service Term			UEP93	UEPQ2	1.15									
	<b>Local Switching</b>														
	Centrex Intercom Functionality, per port			UEP93	URECS	0.8873									
	<b>Local Number Portability</b>														
	Local Number Portability (1 per port)			UEP93	LNPC	0.35									
	<b>Features</b>														
	All Standard Features Offered, per port			UEP93	UEPVF	0.00									
	All Centrex Control Features Offered, per port			UEP93	UEPVC	0.00									
	<b>NARS</b>														
	Unbundled Network Access Register - Combination			UEP93	UARCX	0.00	0.00	0.00							
	Unbundled Network Access Register - Indial			UEP93	UAR1X	0.00	0.00	0.00							
	Unbundled Network Access Register - Outdial			UEP93	UAROX	0.00	0.00	0.00							
	<b>Miscellaneous Terminations</b>														
	<b>2-Wire Trunk Side</b>														
	Trunk Side Terminations, each			UEP93	CEND6	10.51	92.18	15.82	52.16	5.30					
	<b>4-Wire Digital (1.544 Megabits)</b>														
	DS1 Circuit Terminations, each			UEP93	M1HD1	74.77	164.86	77.74	60.69	3.86					
	DS0 Channels Activated, Per Channel			UEP93	M1HDO	0.00	15.09								
	<b>Interoffice Channel Mileage - 2-Wire</b>														
	Interoffice Channel Facilities Termination			UEP93	M1GBC	29.11									
	Interoffice Channel mileage, per mile or fraction of mile			UEP93	M1GBM	0.01									
	<b>Feature Activations (DS0) Centrex Loops on Channelized DS1 Service</b>														
	<b>D4 Channel Bank Feature Activations</b>														
	Feature Activation on D-4 Channel Bank Centrex Loop Slot			UEP93	1PQWS	0.62									
	Feature Activation on D-4 Channel Bank FX Line Side Loop Slot			UEP93	1PQW6	0.62									
	Feature Activation on D-4 Channel Bank FX Trunk Side Loop Slot			UEP93	1PQW7	0.62									
	Feature Activation on D-4 Channel Bank Centrex Loop Slot - Different Wire Center			UEP93	1PQWP	0.62									
	Feature Activation on D-4 Channel Bank Private Line Loop Slot			UEP93	1PQWV	0.62									
	Feature Activation on D-4 Channel Bank Tie Line/Trunk Loop Slot			UEP93	1PQWQ	0.62									
	Feature Activation on D-4 Channel Bank WATS Loop Slot			UEP93	1PQWA	0.62									
	<b>Non-Recurring Charges (NRC) Associated with UNE-P Centrex</b>														
	NRC Conversion Currently Combined Switch-As-Is with allowed changes, per port			UEP93	USAC2		0.102	0.102							
	Conversion of Existing Centrex Common Block, each			UEP93	USACN		18.95	8.32							
	New Centrex Standard Common Block			UEP93	M1ACS	0.00	669.80	78.32	111.05	13.27					
	New Centrex Customized Common Block			UEP93	M1ACC	0.00	669.80	78.32	111.05	13.27					
	NAR Establishment Charge, Per Occasion			UEP93	URECA	0.00	72.75								
	<b>Note 1 - Required Port for Centrex Control in 1AESS, 5ESS &amp; EWSD</b>														
	<b>Note 2 - Requires Interoffice Channel Mileage</b>														
	<b>Note 3 - Requires Specific Customer Premises Equipment</b>														
	<b>Note: Rates displaying an "R" in Interim column are interim and subject to rate true-up as set forth in General Terms and Conditions.</b>														

**Attachment 3**  
**Network Interconnection**

## TABLE OF CONTENTS

<b>1. GENERAL.....</b>	<b>3</b>
<b>2. DEFINITIONS: (FOR THE PURPOSE OF THIS ATTACHMENT) .....</b>	<b>3</b>
<b>3. NETWORK INTERCONNECTION.....</b>	<b>4</b>
<b>4. INTERCONNECTION TRUNK GROUP ARCHITECTURES .....</b>	<b>6</b>
<b>5. NETWORK DESIGN AND MANAGEMENT FOR INTERCONNECTION .....</b>	<b>14</b>
<b>6. LOCAL DIALING PARITY.....</b>	<b>17</b>
<b>7. INTERCONNECTION COMPENSATION .....</b>	<b>18</b>
<b>8. FRAME RELAY SERVICE INTERCONNECTION.....</b>	<b>24</b>
<b>9. ORDERING CHARGES .....</b>	<b>27</b>
<b>Rates</b>	<b>Exhibit A</b>
<b>Basic Architecture</b>	<b>Exhibit B</b>
<b>One Way Architecture</b>	<b>Exhibit C</b>
<b>Two Way Architecture</b>	<b>Exhibit D</b>
<b>Supergroup Architecture</b>	<b>Exhibit E</b>

## NETWORK INTERCONNECTION

### 1. GENERAL

- 1.1 The Parties shall provide interconnection with each other's networks for the transmission and routing of telephone exchange service (Local Traffic), ISP-bound Traffic, and exchange access (Switched Access Traffic) on the following terms:

### 2. DEFINITIONS: (FOR THE PURPOSE OF THIS ATTACHMENT)

- 2.1 For purposes of this attachment only, the following terms shall have the definitions set forth below:
- 2.1.1 **Call Termination** has the meaning set forth for "termination" in 47CFR § 51.701(d).
- 2.1.2 **Call Transport** has the meaning set forth for "transport" in 47 CFR § 51.701(c).
- 2.1.3 **Call Transport and Termination** is used collectively to mean the switching and transport functions from the Interconnection Point to the last point of switching.
- 2.1.4 **Common (Shared) Transport** is defined as the transport of the originating Party's traffic by the terminating Party over the terminating Party's common (shared) facilities between (1) the terminating Party's tandem switch and end office switch, (2) between the terminating Party's tandem switches, and/or (3) between the terminating Party's host and remote end office switches. All switches referred herein must be entered into the Local Exchange Routing Guide (LERG).
- 2.1.5 **Dedicated Interoffice Facility** is defined as a switch transport facility between a Party's Serving Wire Center and the first point of switching within the LATA on the other Party's network.
- 2.1.6 **End Office Switching** is defined as the function that establishes a communications path between the trunk side and line side of the End Office switch.
- 2.1.7 **Fiber Meet** is an interconnection arrangement whereby the Parties physically interconnect their networks via an optical fiber interface at which one Party's facilities, provisioning, and maintenance responsibility begins and the other Party's responsibility ends.
- 2.1.8 **Final Trunk Group** is defined as the trunk group that does not carry overflow traffic.

- 2.1.9 **Interconnection Point (IP)** is the physical telecommunications equipment interface that interconnects the networks of BellSouth and Clearwave Communications.
- 2.1.10 **IntraLATA Toll Traffic** is as defined in Section 7 of this Attachment.
- 2.1.11 **ISP-bound Traffic** is as defined in Section 7 of this Attachment.
- 2.1.12 **Local Channel** is defined as a switched transport facility between a Party's Interconnection Point and the IP's Serving Wire Center.
- 2.1.13 **Local Traffic** is as defined in Section 7 of this Attachment.
- 2.1.14 **Reciprocal Trunk Group** is defined as a one-way trunk group carrying BellSouth originated traffic to be terminated by Clearwave Communications
- 2.1.15 **Serving Wire Center** is defined as the wire center owned by one Party from which the other Party would normally obtain dial tone for its IP.
- 2.1.16 **Tandem Switching** is defined as the function that establishes a communications path between two switching offices through a third switching office through the provision of trunk side to trunk side switching.
- 2.1.17 **Transit Traffic** is traffic originating on Clearwave Communications's network that is switched and/or transported by BellSouth and delivered to a third party's network, or traffic originating on a third party's network that is switched and/or transported by BellSouth and delivered to Clearwave Communications's network.

### **3. NETWORK INTERCONNECTION**

- 3.1 This Attachment pertains only to the provision of network interconnection where Clearwave Communications owns, leases from a third party or otherwise provides its own switch(es).
- 3.2 Network interconnection may be provided by the Parties at any technically feasible point within BellSouth's network. Requests to BellSouth for interconnection at points other than as set forth in this Attachment may be made through the Bona Fide Request/New Business Request (BFR/NBR) process set out in this Agreement.
- 3.2.1 Each Party is responsible for providing, engineering and maintaining the network on its side of the IP. The IP must be located within BellSouth's serving territory in the LATA in which traffic is originating. The IP determines the point at which the originating Party shall pay the terminating Party for the Call Transport and Termination of Local Traffic, ISP-bound Traffic and IntraLATA Toll Traffic.

- 3.2.2 Pursuant to the provisions of this Attachment, the location of the initial IP in a given LATA shall be established by mutual agreement of the Parties. Subject to the requirements for installing additional IPs, as set forth below, any IPs existing prior to the Effective Date of the Agreement will be accepted as initial IPs and will not require re-grooming. When the Parties mutually agree to utilize two-way interconnection trunk groups for the exchange of Local Traffic, ISP-bound Traffic and IntraLATA Toll Traffic between each other, the Parties shall mutually agree to the location of IP(s). If the Parties are unable to agree to a mutual initial IP, each Party, as originating Party, shall establish a single IP in the LATA for the delivery of its originated Local Traffic, ISP-bound Traffic and IntraLATA Toll Traffic to the other Party for Call Transport and Termination by the terminating Party.
- 3.2.3 When first establishing the interconnection arrangement in each LATA, the location of the IP shall be established by mutual agreement of the Parties. In selecting the IP, both Parties will act in good faith and select the point that is most efficient for both Parties. If the Parties are unable to agree on the location of the IP, each Party will designate IPs for its originated traffic. Additional IP(s) in a LATA may be established by mutual agreement of the Parties. Notwithstanding the foregoing, additional IP(s) in a particular LATA shall be established, at the request of either Party, when the Local Traffic and ISP-bound Traffic exceeds 8.9 million minutes per month for three consecutive months at the proposed location of the additional IP. BellSouth will not request the establishment of an IP where physical or virtual collocation space is not available or where BellSouth fiber connectivity is not available. When the Parties agree to utilize two-way interconnection trunk groups for the exchange of Local Traffic, ISP-bound Traffic and IntraLATA Toll Traffic the Parties must agree to the location of the IP(s).

### 3.3 **Interconnection via Dedicated Facilities**

- 3.3.1 **Local Channel Facilities.** As part of Call Transport and Termination, the originating Party may obtain Local Channel facilities from the terminating Party. The percentage of Local Channel facilities utilized for Local Traffic shall be determined based upon the application of the Percent Local Facility (PLF) Factor on a statewide basis. The charges applied to the percentage of Local Channel facilities used for Local Traffic as determined by the PLF are as set forth in Exhibit A to this Attachment. The remaining percentage of Local Channel facilities shall be billed at BellSouth's applicable access tariff rates.
- 3.3.2 **Dedicated Interoffice Facilities.** As a part of Call Transport and Termination, the originating Party may obtain Dedicated Interoffice Facilities from the terminating Party. The percentage of Dedicated Interoffice Facilities utilized for Local Traffic shall be determined based upon the application of the Percent Local Facility (PLF) Factor on a statewide basis. The charges applied to the percentage of the Dedicated Interoffice Facilities used for Local Traffic as determined by the PLF are as set forth in Exhibit A to this Attachment. The remaining percentage of the



Dedicated Interoffice Facilities shall be billed at BellSouth's applicable access tariff rates.

3.3.3 The facilities purchased pursuant to this Section 3 shall be ordered via the Access Service Request (ASR) process.

3.4 **Fiber Meet**

3.4.1 Notwithstanding Section 3.2.1, 3.2.2, and 3.2.3 above, if Clearwave Communications elects to establish interconnection with BellSouth pursuant to a Fiber Meet Local Channel, Clearwave Communications and BellSouth shall jointly engineer, operate and maintain a Synchronous Optical Network (SONET) transmission system by which they shall interconnect their transmission and routing of Local Traffic via a Local Channel at either the DS1 or DS3 level. The Parties shall work jointly to determine the specific transmission system. However, Clearwave Communications's SONET transmission system must be compatible with BellSouth's equipment, and the Data Communications Channel (DCC) must be turned off.

3.4.2 Each Party, at its own expense, shall procure, install and maintain the agreed upon SONET transmission system in its network.

3.4.3 The Parties shall agree to a Fiber Meet point between the BellSouth Serving Wire Center and the Clearwave Communications Serving Wire Center. The Parties shall deliver their fiber optic facilities to the Fiber Meet point with sufficient spare length to reach the fusion splice point for the Fiber Meet Point. BellSouth shall, at its own expense, provide and maintain the fusion splice point for the Fiber Meet. A building type Common Language Location Identification (CLLI) code will be established for each Fiber Meet point. All orders for interconnection facilities from the Fiber Meet point shall indicate the Fiber Meet point as the originating point for the facility.

3.4.4 Upon verbal request by Clearwave Communications, BellSouth shall allow Clearwave Communications access to the fusion splice point for the Fiber Meet point for maintenance purposes on Clearwave Communications's side of the Fiber Meet point.

3.4.5 Neither Party shall charge the other for its Local Channel portion of the Fiber Meet facility used exclusively for Local Traffic. All other appropriate charges will apply. Clearwave Communications shall be billed for a mixed use of the Local Channel using the actual traffic Clearwave Communications elects to transmit over the facility and the rates from this Agreement and the appropriate tariff(s). Charges for switched and special access services shall be billed in accordance with the applicable access service tariff.

**4. INTERCONNECTION TRUNK GROUP ARCHITECTURES**

- 4.1 BellSouth and Clearwave Communications shall establish interconnecting trunk groups and trunk group configurations between networks, including the use of one-way or two-way trunks in accordance with the following provisions set forth in this Agreement. For trunking purposes, traffic will be routed based on the digits dialed by the originating End User and in accordance with the LERG.
- 4.2 Clearwave Communications shall establish an interconnection trunk group(s) to at least one BellSouth access tandem within the LATA for the delivery of Clearwave Communications's originated Local Traffic, ISP-bound Traffic and IntraLATA Toll Traffic and for the receipt and delivery of Transit Traffic. To the extent Clearwave Communications desires to deliver Local Traffic, ISP-bound Traffic, IntraLATA Toll Traffic and/or Transit Traffic to BellSouth access tandems within the LATA, other than the tandems(s) to which Clearwave Communications has established interconnection trunk groups, Clearwave Communications shall order Multiple Tandem Access, as described in this Attachment, to such other BellSouth access tandems.
- 4.2.1 Notwithstanding the forgoing, Clearwave Communications shall establish an interconnection trunk group(s) to all BellSouth access and local tandems in the LATA where Clearwave Communications has homed (i.e. assigned) its NPA/NXXs. Clearwave Communications shall home its NPA/NXXs on the BellSouth tandems that serve the exchange rate center areas to which the NPA/NXXs are assigned. The specified exchange rate center assigned to each BellSouth tandem is defined in the LERG. Clearwave Communications shall enter its NPA/NXX access and/or local tandem homing arrangements into the LERG.
- 4.3 Switched access traffic will be delivered to and from Interexchange Carriers (IXCs) based on Clearwave Communications's NXX access tandem homing arrangement as specified by Clearwave Communications in the LERG.
- 4.4 Any Clearwave Communications interconnection request that (1) deviates from the interconnection trunk group architectures as described in this Agreement, (2) affects traffic delivered to Clearwave Communications from a BellSouth switch, and (3) requires special BellSouth switch translations and other network modifications will require Clearwave Communications to submit a BFR/NBR via the BFR/NBR Process as set forth in this Agreement.
- 4.5 Recurring and nonrecurring rates associated with interconnecting trunk groups between BellSouth and Clearwave Communications are set forth in Exhibit A. To the extent a rate associated with the interconnecting trunk group is not set forth in Exhibit A, the rate shall be as set forth in the appropriate BellSouth tariff for switched access services.
- 4.6 For two-way trunk groups that carry only both Parties' Local Traffic, the Parties shall be compensated at 50% of the nonrecurring and recurring rates for dedicated

trunks and DS1 facilities. Clearwave Communications shall be responsible for ordering and paying for any two-way trunks carrying Transit Traffic.

- 4.7 All trunk groups will be provisioned as Signaling System 7 (SS7) capable where technically feasible. If SS7 is not technically feasible multi-frequency (MF) protocol signaling shall be used.
- 4.8 In cases where Clearwave Communications is also an IXC, the IXC's Feature Group D (FG D) trunk group(s) must remain separate from the local interconnection trunk group(s).
- 4.9 Each Party shall order interconnection trunks and trunk group including trunk and trunk group augmentations via the ASR process. A Firm Order Confirmation (FOC) shall be returned to the ordering Party, after receipt of a valid, error free ASR, within the timeframes set forth in each state's applicable Performance Measures. Notwithstanding the foregoing, blocking situations and projects shall be managed through BellSouth's Carrier Interconnection Switching Center (CISC) Project Management Group and Clearwave Communications's equivalent trunking group, and FOCs for such orders shall be returned in the timeframes applicable to the project. A project is defined as (1) a new trunk group or (2) a request for more than 96 trunks on a single or multiple group(s) in a given BellSouth local calling area.

4.10 **Interconnection Trunk Groups for Exchange of Local Traffic and Transit Traffic**

Upon mutual agreement of the Parties in a joint planning meeting, the Parties' shall exchange Local Traffic on two-way interconnection trunk group(s) with the quantity of trunks being mutually determined and the provisioning being jointly coordinated. Furthermore, the Parties shall agree upon the IP(s) for two-way interconnection trunk groups transporting both Parties' Local Traffic, ISP-bound Traffic and IntraLATA Toll Traffic. Clearwave Communications shall order such two-way trunks via the Access Service Request (ASR) process. BellSouth will use the Trunk Group Service Request (TGSR) to request changes in trunking. Furthermore, the Parties shall jointly review trunk performance and forecasts on a periodic basis. The Parties' use of two-way interconnection trunk groups for the transport of Local Traffic, ISP-bound Traffic and IntraLATA Toll Traffic between the Parties does not preclude either Party from establishing additional one-way interconnection trunks for the delivery of its originated Local Traffic, ISP-bound Traffic and IntraLATA Toll Traffic to the other Party.

4.10.1 **BellSouth Access Tandem Interconnection**

BellSouth access tandem interconnection at a single access tandem provides access to those end offices subtending that access tandem (Intratandem Access). Access tandem interconnection is available for any of the following access tandem architectures

#### 4.10.1.1 **Basic Architecture**

In the basic architecture, Clearwave Communications's originating Local Traffic, ISP-bound Traffic and IntraLATA Toll Traffic and originating and terminating Transit Traffic is transported on a single two-way trunk group between Clearwave Communications and BellSouth access tandem(s) within a LATA to provide Intratandem Access. This trunk group carries Transit Traffic between Clearwave Communications and Independent Companies, Interexchange Carriers, other CLECs, CMRS providers that have a Meet Point Billing arrangement with BellSouth, and other network providers with which Clearwave Communications desires to exchange traffic. This trunk group also carries Clearwave Communications originated Transit Traffic transiting a single BellSouth access tandem destined to third party tandems such as an Independent Company tandem or other CLEC tandem. BellSouth originated Local Traffic, ISP-bound Traffic and IntraLATA Toll Traffic is transported on a separate single one-way trunk group terminating to Clearwave Communications. Other trunk groups for operator services, directory assistance, emergency services and intercept must be established pursuant to the applicable BellSouth tariff if service is requested. The LERG contains current routing and tandem serving arrangements. The basic Architecture is illustrated in Exhibit B.

#### 4.10.1.2 **One-Way Trunk Group Architecture**

In one-way trunk group architecture, the Parties interconnect using three separate trunk groups. A one-way trunk group provides Intratandem Access for Clearwave Communications-originated Local Traffic, ISP-bound Traffic and IntraLATA Toll Traffic destined for BellSouth End Users. A second one-way trunk group carries BellSouth-originated Local Traffic, ISP-bound Traffic and IntraLATA Toll Traffic destined for Clearwave Communications End-Users. A two-way trunk group provides Intratandem Access for Clearwave Communications's originating and terminating Transit Traffic. This trunk group carries Transit Traffic between Clearwave Communications and Independent Companies, Interexchange Carriers, other CLECs, CMRS providers that have a Meet Point Billing arrangement with BellSouth, and other network providers with which Clearwave Communications desires to exchange traffic. This trunk group also carries Clearwave Communications originated Transit Traffic transiting a single BellSouth access tandem destined to third party tandems such as an Independent Company tandem or other CLEC tandem. BellSouth originated Local Traffic, ISP-bound Traffic and IntraLATA Toll Traffic is transported on a separate single one-way trunk group terminating to Clearwave Communications. Other trunk groups for operator services, directory assistance, emergency services and intercept must be established pursuant to the applicable BellSouth tariff if service is requested. The LERG contains current routing and tandem serving arrangements. The one-way trunk group architecture is illustrated in Exhibit C.

#### 4.10.1.3 **Two-Way Trunk Group Architecture**

The two-way trunk group Architecture establishes one two-way trunk group to provide Intratandem Access for the exchange of Local Traffic, ISP-bound Traffic and IntraLATA Toll Traffic between Clearwave Communications and BellSouth. In addition, a separate two-way transit trunk group must be established for Clearwave Communications's originating and terminating Transit Traffic. This trunk group carries Transit Traffic between Clearwave Communications and Independent Companies, Interexchange Carriers, other CLECs, CMRS providers that have a Meet Point Billing arrangement with BellSouth, and other network providers with which Clearwave Communications desires to exchange traffic. This trunk group also carries Clearwave Communications originated Transit Traffic transiting a single BellSouth access tandem destined to third party tandems such as an Independent Company tandem or other CLEC tandem. BellSouth originated traffic may, in order to prevent or remedy traffic blocking situations, be transported on a separate single one-way trunk group terminating to Clearwave Communications. However, where Clearwave Communications is responsive in a timely manner to BellSouth's transport needs for its originated traffic, BellSouth originating traffic will be placed on the two-way Local Traffic trunk group carrying ISP-bound Traffic and IntraLATA Toll Traffic. Other trunk groups for operator services, directory assistance, emergency services and intercept must be established pursuant to the applicable BellSouth tariff if service is requested. The LERG contains current routing and tandem serving arrangements. The two-way trunk group architecture is illustrated in Exhibit D.

#### 4.10.1.4 **Supergroup Architecture**

In the supergroup architecture, the Parties' Local Traffic, ISP-bound Traffic and IntraLATA Toll Traffic and Clearwave Communications's Transit Traffic are exchanged on a single two-way trunk group between Clearwave Communications and BellSouth to provide Intratandem Access to Clearwave Communications. This trunk group carries Transit Traffic between Clearwave Communications and Independent Companies, Interexchange Carriers, other CLECs, CMRS providers that have a Meet Point Billing arrangement with BellSouth, and other network providers with which Clearwave Communications desires to exchange traffic. This trunk group also carries Clearwave Communications originated Transit Traffic transiting a single BellSouth access tandem destined to third party tandems such as an Independent Company tandem or other CLEC tandem. BellSouth originated traffic may, in order to prevent or remedy traffic blocking situations, be transported on a separate single one-way trunk group terminating to Clearwave Communications. However, where Clearwave Communications is responsive in a timely manner to BellSouth's transport needs for its originated traffic, BellSouth originating traffic will be placed on the Supergroup. Other trunk groups for operator services, directory assistance, emergency services and intercept must be established pursuant to the applicable BellSouth tariff if service is requested. The LERG contains current routing and tandem serving arrangements. The supergroup architecture is illustrated in Exhibit E.

#### 4.10.1.5 **Multiple Tandem Access Interconnection**

- 4.10.1.5.1 Where Clearwave Communications does not choose access tandem interconnection at every BellSouth access tandem within a LATA, Clearwave Communications may utilize BellSouth's multiple tandem access interconnection (MTA). To utilize MTA Clearwave Communications must establish an interconnection trunk group(s) at a BellSouth access tandem through multiple BellSouth access tandems within the LATA as required. BellSouth will route Clearwave Communications's originated Local Traffic, ISP-bound Traffic and IntraLATA Toll Traffic for LATA wide transport and termination. Clearwave Communications must also establish an interconnection trunk group(s) at all BellSouth access tandems where Clearwave Communications NXXs are homed as described in Section 4.2.1 above. If Clearwave Communications does not have NXXs homed at any particular BellSouth access tandem within a LATA and elects not to establish an interconnection trunk group(s) at such BellSouth access tandem, Clearwave Communications can order MTA in each BellSouth access tandem within the LATA where it does have an interconnection trunk group(s) and BellSouth will terminate Clearwave Communications's Local Traffic, ISP-bound Traffic and IntraLATA Toll Traffic to End-Users served through those BellSouth access tandems where Clearwave Communications does not have an interconnection trunk group(s). MTA shall be provisioned in accordance with BellSouth's Ordering Guidelines.
- 4.10.1.5.2 Clearwave Communications may also utilize MTA to route its originated Transit Traffic; provided, however, that MTA may not be utilized to route switched access traffic that transits the BellSouth network to an Interexchange Carrier (IXC). Switched access traffic originated by or terminated to Clearwave Communications will be delivered to and from IXCs based on Clearwave Communications's NXX access tandem homing arrangement as specified by Clearwave Communications in the LERG.
- 4.10.1.5.3 Compensation for MTA shall be at the applicable tandem switching and transport charges specified in Exhibit A to this Attachment and shall be billed in addition to any Call Transport and Termination charges.
- 4.10.1.5.4 To the extent Clearwave Communications does not purchase MTA in a LATA served by multiple access tandems, Clearwave Communications must establish an interconnection trunk group(s) to every access tandem in the LATA to serve the entire LATA. To the extent Clearwave Communications routes its traffic in such a way that utilizes BellSouth's MTA service without properly ordering MTA, Clearwave Communications shall pay BellSouth the associated MTA charges.
- 4.10.2 **Local Tandem Interconnection**
- 4.10.2.1 Local Tandem Interconnection arrangement allows Clearwave Communications to establish an interconnection trunk group(s) at BellSouth local tandems for: (1) the delivery of Clearwave Communications-originated Local Traffic, ISP-bound Traffic and IntraLATA Toll Traffic transported and terminated by BellSouth to

BellSouth end offices served by those BellSouth local tandems, and (2) for local Transit Traffic transported by BellSouth for third party network providers who have also established an interconnection trunk group(s) at those BellSouth local tandems.

- 4.10.2.2 When a specified local calling area is served by more than one BellSouth local tandem, Clearwave Communications must designate a “home” local tandem for each of its assigned NPA/NXXs and establish trunk connections to such local tandems. Additionally, Clearwave Communications may choose to establish an interconnection trunk group(s) at the BellSouth local tandems where it has no codes homing but is not required to do so. Clearwave Communications may deliver Local Traffic, ISP-bound Traffic and IntraLATA Toll Traffic to a “home” BellSouth local tandem that is destined for other BellSouth or third party network provider end offices subtending other BellSouth local tandems in the same local calling area where Clearwave Communications does not choose to establish an interconnection trunk group(s). It is Clearwave Communications’s responsibility to enter its own NPA/NXX local tandem homing arrangements into the LERG either directly or via a vendor in order for other third party network providers to determine appropriate traffic routing to Clearwave Communications’s codes. Likewise, Clearwave Communications shall obtain its routing information from the LERG.
- 4.10.2.3 Notwithstanding establishing an interconnection trunk group(s) to BellSouth’s local tandems, Clearwave Communications must also establish an interconnection trunk group(s) to BellSouth access tandems within the LATA on which Clearwave Communications has NPA/NXXs homed for the delivery of Interexchange Carrier Switched Access (SWA) and toll traffic, and traffic to Type 2A CMRS connections located at the access tandems. BellSouth shall not switch SWA traffic through more than one BellSouth access tandem. SWA, Type 2A CMRS or toll traffic routed to the local tandem in error will not be backhauled to the BellSouth access tandem for completion. (Type 2A CMRS interconnection is defined in BellSouth’s A35 General Subscriber Services Tariff).
- 4.10.2.4 BellSouth’s provisioning of Local Tandem Interconnection assumes that Clearwave Communications has executed the necessary local interconnection agreements with the other third party network providers subtending those local tandems as required by the Act.
- 4.10.3 **Direct End Office-to-End Office Interconnection**
- 4.10.3.1 Direct End Office-to-End Office one-way or two-way interconnection trunk groups allow for the delivery of a Party’s originating Local Traffic, ISP-bound Traffic and IntraLATA Toll Traffic to the terminating Party on a direct end office-to-end office basis.

- 4.10.3.2 The Parties shall utilize direct end office-to-end office trunk groups under any one of the following conditions:
- 4.10.3.2.1 Tandem Exhaust - If a tandem through which the Parties are interconnected is unable to, or is forecasted to be unable to support additional traffic loads for any period of time, the Parties will mutually agree on an end office trunking plan that will alleviate the tandem capacity shortage and ensure completion of traffic between Clearwave Communications and BellSouth.
- 4.10.3.2.2 Traffic Volume –To the extent either Party has the capability to measure the amount of traffic between Clearwave Communications’s switch and a BellSouth end office and where such traffic exceeds or is forecasted to exceed a single DS1 of traffic per month, then the Parties shall install and retain direct end office trunking sufficient to handle such traffic volumes. Either Party will install additional capacity between such points when overflow traffic exceeds or is forecasted to exceed a single DS1 of traffic per month. In the case of one-way trunking, additional trunking shall only be required by the Party whose trunking has achieved the preceding usage threshold.
- 4.10.3.2.3 Mutual Agreement - The Parties may install direct end office trunking upon mutual agreement in the absence of conditions (1) or (2) above.
- 4.10.4 **Transit Traffic Trunk Group**
- Transit Traffic trunks can either be two-way trunks or two one-way trunks ordered by Clearwave Communications to deliver and receive Transit Traffic. Establishing Transit Traffic trunks at BellSouth access and local tandems provides intratandem access to the third parties also interconnected at those tandems.
- 4.10.4.1 **Toll Free Traffic**
- 4.10.4.1.1 If Clearwave Communications chooses BellSouth to perform the Service Switching Point (SSP) Function (i.e., handle Toll Free database queries) from BellSouth’s switches, all Clearwave Communications originating Toll Free traffic will be routed over the Transit Traffic Trunk Group and shall be delivered using GR-394 format. Carrier Code “0110” and Circuit Code (to be determined for each LATA) shall be used for all such calls.
- 4.10.4.1.2 Clearwave Communications may choose to perform its own Toll Free database queries from its switch. In such cases, Clearwave Communications will determine the nature (local/intraLATA/interLATA) of the Toll Free call (local/IntraLATA/InterLATA) based on the response from the database. If the call is a BellSouth local or intraLATA Toll Free call, Clearwave Communications will route the post-query local or IntraLATA converted ten-digit local number to BellSouth over the local or intraLATA trunk group. If the call is a third party (ICO, IXC, CMRS or other CLEC) local or intraLATA Toll Free call, Clearwave Communications will route the post-query local or intraLATA converted ten-digit



local number to BellSouth over the Transit Traffic Trunk Group and Clearwave Communications shall provide to BellSouth a Toll Free billing record when appropriate. If the query reveals the call is an interLATA Toll Free call, Clearwave Communications will route the post-query interLATA Toll Free call (1) directly from its switch for carriers interconnected with its network or (2) over the Transit Traffic Trunk Group to carriers that are not directly connected to Clearwave Communications's network but that are connected to BellSouth's access tandem.

- 4.10.5 All post-query Toll Free calls for which Clearwave Communications performs the SSP function, if delivered to BellSouth, shall be delivered using GR-394 format for calls destined to IXCs, and GR-317 format for calls destined to end offices that directly subtend a BellSouth access tandem within the LATA.

## **5. NETWORK DESIGN AND MANAGEMENT FOR INTERCONNECTION**

- 5.1 Network Management and Changes. The Parties will exchange toll-free maintenance contact numbers and escalation procedures. The Parties will provide public notice of network changes in accordance with applicable federal and state rules and regulations.
- 5.2 Interconnection Technical Standards. The interconnection of all networks will be based upon accepted industry/national guidelines for transmission standards and traffic blocking criteria. Interconnecting facilities shall conform, at a minimum, to the telecommunications industry standard of DS-1 pursuant to Telcordia Standard No. TR-NWT-00499. Where Clearwave Communications chooses to utilize Signaling System 7 signaling, also known as Common Channel Signaling (SS7), SS7 connectivity is required between the Clearwave Communications switch and the BellSouth Signaling Transfer Point (STP). BellSouth will provide SS7 signaling using Common Channel Signaling Access Capability in accordance with the technical specifications set forth in the BellSouth Guidelines to Technical Publication, TR-TSV-000905. Facilities of each Party shall provide the necessary on-hook, off-hook answer and disconnect supervision and shall provide calling number ID (Calling Party Number) when technically feasible.
- 5.3 Quality of Interconnection. The local interconnection for the transmission and routing of telephone exchange service and exchange access that each Party provides to each other will be at least equal in quality to what it provides to itself and any subsidiary or affiliate, where technically feasible, or to any other Party to which each Party provides local interconnection.
- 5.4 Network Management Controls. Both Parties will work cooperatively to apply sound network management principles by invoking appropriate network management controls (e.g., call gapping) to alleviate or prevent network congestion.

- 5.5 SS7 Signaling. Both Parties will utilize LEC-to-LEC SS7 Signaling, where available, in conjunction with all traffic in order to enable full interoperability of CLASS features and functions except for call return. All SS7 signaling parameters will be provided, including but not limited to automatic number identification (ANI), originating line information (OLI) calling company category and charge number. All privacy indicators will be honored, and the Parties will exchange Transactional Capabilities Application Part (TCAP) messages to facilitate full interoperability of SS7-based features between the respective networks. Neither Party shall alter the SS7 parameters, or be a party to altering such parameters, or knowingly pass SS7 parameters that have been altered in order to circumvent appropriate interconnection charges.
- 5.6 Signaling Call Information. BellSouth and Clearwave Communications will send and receive 10 digits for Local Traffic. Additionally, BellSouth and Clearwave Communications will exchange the proper call information, i.e. originated call company number and destination call company number, CIC, and OZZ, including all proper translations for routing between networks and any information necessary for billing.
- 5.7 **Forecasting for Trunk Provisioning**
- 5.7.1 Within six (6) months after execution of this Agreement, Clearwave Communications shall provide an initial interconnection trunk group forecast for each LATA in which it plans to provide service within BellSouth's region. Upon receipt of Clearwave Communications's forecast, the Parties shall conduct a joint planning meeting to develop a joint interconnection trunk group forecast. Each forecast provided under this Section shall be deemed "Confidential Information" under the General Terms and Conditions of this Agreement.
- 5.7.1.1 At a minimum, the forecast shall include the projected quantity of Transit Trunks, Clearwave Communications-to-BellSouth one-way trunks (Clearwave Communications Trunks), BellSouth-to-Clearwave Communications one-way trunks (Reciprocal Trunk Groups) and/or two-way interconnection trunks, if the Parties have agreed to interconnect using two-way trunking to transport the Parties' Local Traffic and IntraLATA Toll Traffic. The quantities shall be projected for a minimum of six months and shall include an estimate of the current year plus the next two years total forecasted quantities. The Parties shall mutually develop Reciprocal Trunk Groups and/or two-way interconnection trunk forecast quantities.
- 5.7.1.2 All forecasts shall include, at a minimum, Access Carrier Terminal Location (ACTL), trunk group type (local/intraLATA toll, Transit, Operator Services, 911, etc.), A location/Z location (CLLI codes for Clearwave Communications location and BellSouth location where the trunks shall terminate), interface type (e.g., DS1), Direction of Signaling, Trunk Group Number, if known, (commonly

referred to as the 2-6 code) and forecasted trunks in service each year (cumulative).

5.7.2 Once initial interconnection trunk forecasts have been developed, Clearwave Communications shall continue to provide interconnection trunk forecasts on a semiannual basis or at otherwise mutually agreeable intervals. Clearwave Communications shall use its best efforts to make the forecasts as accurate as possible based on reasonable engineering criteria. The Parties shall continue to develop Reciprocal Trunk Group and/or two-way interconnection trunk forecasts as described in Section 5.7.1.1.

5.7.3 The submitting and development of interconnection trunk forecasts shall not replace the ordering process for local interconnection trunks. Each Party shall exercise its best efforts to provide the quantity of interconnection trunks mutually forecasted. However, the provision of the forecasted quantity of interconnection trunks is subject to trunk terminations and facility capacity existing at the time the trunk order is submitted. Furthermore, the receipt and development of trunk forecasts does not imply any liability for failure to perform if capacity (trunk terminations or facilities) is not available for use at the forecasted time.

## 5.8 **Trunk Utilization**

5.8.1 For the Reciprocal Trunk Groups that are Final Trunk Groups (Reciprocal Final Trunk Groups), BellSouth and Clearwave Communications shall monitor traffic on each interconnection Reciprocal Final Trunk Group that is ordered and installed. The Parties agree that the Reciprocal Final Trunk Groups will be utilized at 60 percent (60%) of the time consistent busy hour utilization level within 90 days of installation. The Parties agree that the Reciprocal Final Trunk Groups will be utilized at eighty percent (80%) of the time consistent busy hour utilization level within 180 days of installation. Any Reciprocal Final Trunk Group not meeting the minimum thresholds set forth in this Section are defined as "Under-utilized" trunks. BellSouth may disconnect any Under-utilized Reciprocal Final Trunk Groups and Clearwave Communications shall refund to BellSouth the associated nonrecurring and recurring trunk and facility charges paid by BellSouth, if any.

5.8.1.1 BellSouth's CISC will notify Clearwave Communications of any under-utilized Reciprocal Trunk Groups and the number of such trunk groups that BellSouth wishes to disconnect. BellSouth will provide supporting information either by email or facsimile to the designated Clearwave Communications interface. Clearwave Communications will provide concurrence with the disconnection in seven (7) business days or will provide specific information supporting why the trunks should not be disconnected. Such supporting information should include expected traffic volumes (including traffic volumes generated due to Local Number Portability) and the timeframes within which Clearwave Communications expects to need such trunks. BellSouth's CISC Project Manager and Circuit Capacity Manager will discuss the information with Clearwave Communications to

determine if agreement can be reached on the number of Reciprocal Final Trunk Groups to be removed. If no agreement can be reached, BellSouth will issue disconnect orders to Clearwave Communications. The due date of these orders will be four weeks after Clearwave Communications was first notified in writing of the underutilization of the trunk groups.

- 5.8.2 To the extent that any interconnection trunk group is utilized at a time-consistent busy hour of eighty percent (80%) or greater, the Parties may review the trunk groups and, if necessary, shall negotiate in good faith for the installation of augmented facilities.
- 5.8.3 For the two-way trunk groups, BellSouth and Clearwave Communications shall monitor traffic on each interconnection trunk group that is ordered and installed. The Parties agree that within 90 days of the installation of the BellSouth two-way trunk or trunks, the trunks will be utilized at 60 percent (60%) of the time consistent busy hour utilization level. The Parties agree that within 180 days of the installation of a trunk or trunks, the trunks will be utilized at eighty percent (80%) of the time consistent busy hour utilization level. Any trunk or trunks not meeting the minimum thresholds set forth in this Section are defined as "Under-utilized" trunks. BellSouth will request the disconnection of any Under-utilized two-way trunk(s) and Clearwave Communications shall refund to BellSouth the associated nonrecurring and recurring trunk and facility charges paid by BellSouth, if any.
- 5.8.3.1 BellSouth's LISC will notify Clearwave Communications of any under-utilized two-way trunk groups and the number of trunks that BellSouth wishes to disconnect. BellSouth will provide supporting information either by email or facsimile to the designated Clearwave Communications interface. Clearwave Communications will provide concurrence with the disconnection in seven (7) business days or will provide specific information supporting why the two-way trunks should not be disconnected. Such supporting information should include expected traffic volumes (including traffic volumes generated due to Local Number Portability) and the timeframes within which Clearwave Communications expects to need such trunks. BellSouth's CISC Project Manager and Circuit Capacity Manager will discuss the information with Clearwave Communications to determine if agreement can be reached on the number of trunks to be removed. If no agreement can be reached, Clearwave Communications will issue disconnect orders to BellSouth. The due date of these orders will be four weeks after Clearwave Communications was first notified in writing of the underutilization of the trunk groups.
- 5.8.3.2 To the extent that any interconnection trunk group is utilized at a time-consistent busy hour of eighty percent (80%) or greater, the Parties may review the trunk groups and, if necessary, shall negotiate in good faith for the installation of augmented facilities.

## **6. LOCAL DIALING PARITY**

6.1 BellSouth and Clearwave Communications shall provide local and toll dialing parity, as defined in FCC rules and regulations, with no unreasonable dialing delays. Dialing parity shall be provided for all originating telecommunications services that require dialing to route a call.

## **7. INTERCONNECTION COMPENSATION**

### **7.1 Compensation for Call Transportation and Termination for Local Traffic, ISP-bound Traffic and IntraLATA Toll Traffic**

7.1.1 For the purposes of this Attachment and for reciprocal compensation between the Parties pursuant to this Attachment, Local Traffic is defined as any telephone call that originates in one exchange and terminates in either the same exchange, or other local calling area associated with the originating exchange as defined and specified in Section A3 of BellSouth's General Subscriber Service Tariff.

7.1.1.1 Additionally, Local Traffic includes any cross boundary, voice-to-voice intrastate, interLATA or interstate, interLATA calls established as a local call by the ruling regulatory body.

7.1.2 ISP-bound Traffic is defined as calls to an information service provider or Internet service provider (ISP) that are dialed by using a local dialing pattern (7 or 10 digits) by a calling party in one exchange to an ISP server or modem in either the same exchange or a corresponding Extended Area Service (EAS) exchange as defined and specified in Section A3 of BellSouth's General Subscriber Service tariff. ISP-bound Traffic is not Local Traffic subject to reciprocal compensation, but instead is information access traffic subject to the FCC's jurisdiction.

7.1.3 Notwithstanding the definitions of Local Traffic and ISP-bound traffic above, and pursuant to the FCC's Order on Remand and Report and Order in CC Docket 99-68 released April 27, 2001 (ISP Order on Remand), BellSouth and Clearwave Communications agree to the rebuttable presumption that all combined circuit switched Local and ISP-bound Traffic delivered to BellSouth or Clearwave Communications that exceeds a 3:1 ratio of terminating to originating traffic on a statewide basis shall be considered ISP-bound traffic for compensation purposes. BellSouth and Clearwave Communications further agree to the rebuttable presumption that all combined circuit switched Local and ISP-bound Traffic delivered to BellSouth or Clearwave Communications that does not exceed a 3:1 ratio of terminating to originating traffic on a statewide basis shall be considered Local Traffic for compensation purposes.

7.1.4 Neither Party shall pay compensation to the other Party for per minute of use rate elements associated with the Call Transport and Termination of Local Traffic or ISP-bound Traffic.

- 7.1.5 The appropriate elemental rates set forth in Exhibit A of this Attachment shall apply for Transit Traffic as described in Sections 7.6 and 7.6.1 below and to Multiple Tandem Access as described in Section 4.10.1.5 above.
- 7.1.6 Neither Party shall represent Switched Access Traffic as Local Traffic or ISP-bound Traffic for purposes of determining compensation for the call.
- 7.1.7 IntraLATA Toll Traffic is defined as all traffic that originates and terminates within a single LATA that is not Local or ISP-bound traffic under this Attachment.
- 7.1.7.1 For terminating its intraLATA toll traffic on the other company's network, the originating Party will pay the terminating Party BellSouth's current intrastate or interstate, whichever is appropriate, terminating switched access tariff rates as set forth in BellSouth's Access Services Tariffs as filed and in effect with the FCC or Commission. The appropriate charges will be determined by the routing of the call. Additionally, if one Party is the other Party's End User's presubscribed interexchange carrier or if one Party's End User uses the other Party as an interexchange carrier on a 101XXXX basis, the originating party will charge the other Party the appropriate BellSouth originating switched access tariff rates as set forth in BellSouth's Intrastate or Interstate Access Services Tariff as filed and in effect with the FCC or appropriate Commission.
- 7.1.8 If Clearwave Communications assigns NPA/NXXs to specific BellSouth rate centers within the LATA and assigns numbers from those NPA/NXXs to Clearwave Communications End Users physically located outside of that LATA, BellSouth traffic originating from within the LATA where the NPA/NXXs are assigned and delivered to a Clearwave Communications customer physically located outside of such LATA, shall not be deemed Local Traffic. Further, Clearwave Communications agrees to identify such interLATA traffic to BellSouth and to compensate BellSouth for originating and transporting such interLATA traffic to Clearwave Communications at BellSouth's switched access tariff rates.
- 7.2 If Clearwave Communications does not identify such interLATA traffic to BellSouth, to the best of BellSouth's ability BellSouth will determine which whole Clearwave Communications NPA/NXXs on which to charge the applicable rates for originating network access service as reflected in BellSouth's Access Service Tariff. BellSouth shall make appropriate billing adjustments if Clearwave Communications can provide sufficient information for BellSouth to determine whether or not said traffic is Local or ISP-bound Traffic.
- 7.3 **Jurisdictional Reporting**
- 7.3.1 **Percent Local Use.** Each Party shall report to the other a Percent Local Usage (PLU) factor. The application of the PLU will determine the amount of local or ISP-bound minutes to be billed to the other Party. Each Party shall update its PLU on the first of January, April, July and October of the year and shall send it to the

other Party to be received no later than 30 days after the first of each such month based on local and ISP-bound usage for the past three months ending the last day of December, March, June and September, respectively. Requirements associated with PLU calculation and reporting shall be as set forth in BellSouth's Jurisdictional Factors Reporting Guide, as it is amended from time to time.

- 7.3.2 **Percent Local Facility.** Each Party shall report to the other a Percent Local Facility (PLF) factor. The application of the PLF will determine the portion of switched dedicated transport to be billed per the local jurisdiction rates. The PLF shall be applied to Multiplexing, Local Channel and Interoffice Channel Switched Dedicated Transport utilized in the provision of local interconnection trunks. Each Party shall update its PLF on the first of January, April, July and October of the year and shall send it to the other Party to be received no later than 30 days after the first of each such month to be effective the first bill period the following month, respectively. Requirements associated with PLU and PLF calculation and reporting shall be as set forth in BellSouth's Jurisdictional Factors Reporting Guide, as it is amended from time to time.
- 7.3.3 **Percent Interstate Usage.** Each Party shall report to the other the projected Percent Interstate Usage (PIU) factor. All jurisdictional report requirements, rules and regulations for Interexchange Carriers specified in BellSouth's Intrastate Access Services Tariff will apply to Clearwave Communications. After interstate and intrastate traffic percentages have been determined by use of PIU procedures, the PLU and PLF factors will be used for application and billing of local interconnection. Each Party shall update its PIUs on the first of January, April, July and October of the year and shall send it to the other Party to be received no later than 30 days after the first of each such month, for all services showing the percentages of use for the past three months ending the last day of December, March, June and September.
- 7.3.4 Notwithstanding the provisions in Section 7.3.1, 7.3.2, and 7.3.3 above, where the terminating Party has message recording technology that identifies the jurisdiction of traffic terminated as defined in this Agreement, such information shall, at the terminating Party's option, be utilized to determine the appropriate jurisdictional reporting factors (PLU, PIU, and/or PLF), in lieu of those provided by the originating Party. In the event that the terminating Party opts to utilize its own data to determine jurisdictional reporting factors, such terminating Party shall notify the originating Party at least 15 days prior to the beginning of the calendar quarter in which the terminating Party will begin to utilize its own data. Such factors shall subject to the Dispute Resolution provisions in this Agreement, as well as the Audit provisions set forth in 7.3.5 below.
- 7.3.5 **Audits.** On thirty (30) days written notice, each Party must provide the other the ability and opportunity to conduct an annual audit to ensure the proper billing of traffic. BellSouth and Clearwave Communications shall retain records of call

detail for a minimum of nine months from which the PLU, PLF and/or PIU can be ascertained. The audit shall be conducted during normal business hours at an office designated by the Party being audited. Audit requests shall not be submitted more frequently than one (1) time per calendar year. Audits shall be performed by a mutually acceptable independent auditor paid for by the Party requesting the audit. The PLF, PLU and/or PIU shall be adjusted based upon the audit results and shall apply for the quarter the audit was completed, for the quarter prior to the completion of the audit, and for the two quarters following the completion of the audit. If, as a result of an audit, either Party is found to have overstated the PLF, PLU and/or PIU by twenty percentage points (20%) or more, that Party shall reimburse the auditing Party for the cost of the audit.

#### 7.4 **Compensation for 8XX Traffic**

7.4.1 Compensation for 8XX Traffic. Each Party shall pay the other the appropriate switched access charges set forth in the BellSouth intrastate or interstate switched access tariffs. Clearwave Communications will pay BellSouth the database query charge as set forth in the BellSouth intrastate or interstate switched access tariffs as applicable.

7.4.2 Records for 8XX Billing. Each Party will provide to the other the appropriate records necessary for billing intraLATA 8XX customers. The records provided will be in a standard EMI format.

7.4.3 8XX Access Screening. BellSouth's provision of 8XX Toll Free Dialing (TFD) to Clearwave Communications requires interconnection from Clearwave Communications to BellSouth's 8XX Signal Channel Point (SCP). Such interconnections shall be established pursuant to BellSouth's Common Channel Signaling Interconnection Guidelines and Telcordia's CCS Network Interface Specification document, TR-TSV-000905. Clearwave Communications shall establish SS7 interconnection at the BellSouth Local Signal Transfer Points serving the BellSouth 8XX SCPs that Clearwave Communications desires to query. The terms and conditions for 8XX TFD are set out in BellSouth's Intrastate Access Services Tariff.

#### 7.5 **Mutual Provision of Switched Access Service**

7.5.1 Switched Access Traffic. Switched Access Traffic is described as telephone calls requiring local transmission or switching services for the purpose of the origination or termination of Telephone Toll Service. Switched Access Traffic includes, but is not limited to, the following types of traffic: Feature Group A, Feature Group B, Feature Group C, Feature Group D, toll free access (e.g., 8XX), 900 access and their successors. Additionally, any Public Switched Telephone Network interexchange telecommunications traffic, regardless of transport protocol method, where the originating and terminating points, end-to-end points, are in different LATAs, or are in the same LATA and the Parties' Switched Access services are



used for the origination or termination of the call, shall be considered Switched Access Traffic. Irrespective of transport protocol method used, a call which originates in one LATA and terminates in another LATA (i.e., the end-to-end points of the call) or in which the Parties' Switched Access Services are used for the origination or termination of the call, shall not be considered Local Traffic or ISP-bound Traffic.

- 7.5.2 If the BellSouth End User chooses Clearwave Communications as their presubscribed interexchange carrier, or if the BellSouth End User uses Clearwave Communications as an interexchange carrier on a 101XXXX basis, BellSouth will charge Clearwave Communications the appropriate BellSouth tariff charges for originating switched access services.
- 7.5.3 Where the originating Party delivers a call to the terminating Party over switched access facilities, the originating Party will pay the terminating Party terminating, switched access charges as set forth in BellSouth's Intrastate or Interstate Access Services Tariff, as appropriate.
- 7.5.4 When Clearwave Communications's end office switch provides an access service connection to or from an interexchange carrier (IXC) by a direct trunk group to the IXC utilizing BellSouth facilities, each Party will provide its own access services to the IXC and bill on a multi-bill, multi-tariff meet-point basis. Each Party will bill its own access services rates to the IXC with the exception of the interconnection charge. The interconnection charge will be billed by Clearwave Communications as the Party providing the end office function. Each party will use the Multiple Exchange Carrier Access Billing (MECAB) guidelines to establish meet point billing for all applicable traffic. The Parties shall utilize a thirty (30) day billing period.
- 7.5.4.1 When Clearwave Communications's end office subtends the BellSouth Access Tandem switch for receipt or delivery of switched access traffic and provides an access service connection to or from an IXC via BellSouth's Access Tandem switch, BellSouth, as the tandem company agrees to provide to Clearwave Communications, as the End Office Company, as defined in MECAB, at no charge, all the switched access detail usage data, recorded at the access tandem, within no more than sixty (60) days after the recording date. Each Party will notify the other when it is not feasible to meet these requirements. As business requirements change, data reporting requirements may be modified as necessary.
- 7.5.5 BellSouth, as the tandem provider company, will retain for a minimum period of sixty (60) days, access message detail sufficient to recreate any data that is lost or damaged by the tandem provider company or any third party involved in processing or transporting data.

- 7.5.6 BellSouth, as the tandem provider company, agrees to recreate the lost or damaged data within forty-eight (48) hours of notification by the other or by an authorized third party handling the data.
- 7.5.7 Any claims against BellSouth, as the tandem provider company, for unbillable or uncollectible revenue should be filed with the tandem provider company within 120 days of the usage date.
- 7.5.8 BellSouth, as the tandem provider company shall keep records of its billing activities relating to jointly-provided Intrastate and Interstate access services in sufficient detail to permit the Subsequent Billing Party to, by formal or informal review or audit, to verify the accuracy and reasonableness of the jointly-provided access billing data provided by the Initial Billing Party. Each Party agrees to cooperate in such formal or informal reviews or audits and further agrees to jointly review the findings of such reviews or audits in order to resolve any differences concerning the findings thereof.
- 7.5.9 Clearwave Communications agrees not to deliver switched access traffic to BellSouth for termination except over Clearwave Communications ordered switched access trunks and facilities.
- 7.6 **Transit Traffic**
- 7.6.1 BellSouth shall provide tandem switching and transport services for Clearwave Communications's Transit Traffic. Rates for local Transit Traffic and ISP-bound Transit Traffic shall be the applicable Call Transport and Termination charges as set forth in Exhibit A to this Attachment. Rates for Switched Access Transit Traffic shall be the applicable charges as set forth in BellSouth Interstate or Intrastate Switched Access tariffs. Billing associated with all Transit Traffic shall be pursuant to MECAB guidelines. Traffic between Clearwave Communications and Wireless Type 1 third parties shall not be treated as Transit Traffic from a routing or billing perspective. Traffic between Clearwave Communications and Wireless Type 2A or a third party CLEC utilizing BellSouth switching shall not be treated as Transit Traffic from a routing or billing perspective until BellSouth and the Wireless carrier or a third party CLEC utilizing BellSouth switching have the capability to properly meet-point-bill in accordance with MECAB guidelines.
- 7.6.2 The delivery of traffic that transits the BellSouth network and is transported to another carrier's network is excluded from any BellSouth billing guarantees. BellSouth agrees to deliver Transit Traffic to the terminating carrier; provided, however, that Clearwave Communications is solely responsible for negotiating and executing any appropriate contractual agreements with the terminating carrier for the exchange of Transit Traffic through the BellSouth network. BellSouth will not be liable for any compensation to the terminating carrier or to Clearwave Communications. In the event that the terminating third party carrier imposes on BellSouth any charges or costs for the delivery of Transit Traffic, Clearwave

Communications shall reimburse BellSouth for such costs. Additionally, the Parties agree that any billing to a third party or other telecommunications carrier under this section shall be pursuant to MECAB procedures.

## **8. FRAME RELAY SERVICE INTERCONNECTION**

- 8.1 In addition to the Local Interconnection services set forth above, BellSouth will offer a network to network Interconnection arrangement between BellSouth's and Clearwave Communications's frame relay switches as set forth below. The following provisions will apply only to Frame Relay Service and Exchange Access Frame Relay Service and Managed Shared Frame Relay Service in those states in which Clearwave Communications is certified and providing Frame Relay Service as a Local Exchange Carrier and where traffic is being exchanged between Clearwave Communications and BellSouth Frame Relay Switches in the same LATA.
- 8.2 The Parties agree to establish two-way Frame Relay facilities between their respective Frame Relay Switches to the mutually agreed upon Frame Relay Service point(s) of interconnection (IP(s)) within the LATA. All IPs shall be within the same Frame Relay Network Serving Areas as defined in Section A40 of BellSouth's General Subscriber Service Tariff except as set forth in this Attachment.
- 8.3 Upon the request of either Party, such interconnection will be established where BellSouth and Clearwave Communications have Frame Relay Switches in the same LATA. Where there are multiple Frame Relay switches in one central office, an interconnection with any one of the switches will be considered an interconnection with all of the switches at that central office for purposes of routing packet traffic.
- 8.4 The Parties agree to provision local and intraLATA Frame Relay Service and Exchange Access Frame Relay Service and Managed Shared Frame Relay Service (both intrastate and interstate) over Frame Relay interconnection facilities between the respective Frame Relay switches and the IPs.
- 8.5 The Parties agree to assess each other reciprocal charges for the facilities that each provides to the other according to the Percent Local Circuit Use Factor (PLCU), determined as follows:
- 8.5.1 If the data packets originate and terminate in locations in the same LATA, and are consistent with the local definitions of the Agreement, the traffic is considered local. Frame Relay framed packet data is transported within Virtual Circuits (VC). For the purposes of this Agreement, if all the data packets transported within a VC remain within the LATA, then consistent with the local definitions in this Agreement, the traffic on that VC is local (Local VC).

- 8.5.2 If the originating and terminating locations of the two-way packet data traffic are not in the same LATA, the traffic on that VC is interLATA (InterLATA VC).
- 8.5.3 The PLCU is determined by dividing the total number of Local VCs, by the total number of VCs on each Frame Relay facility. To facilitate implementation, Clearwave Communications may determine its PLCU in aggregate, by dividing the total number of Local VCs in a given LATA by the total number VCs in that LATA. The Parties agree to renegotiate the method for determining PLCU, at BellSouth's request, and within 90 days, if BellSouth notifies Clearwave Communications that it has found that this method does not adequately represent the PLCU.
- 8.5.4 If there are no VCs on a facility when it is billed, the PLCU will be zero.
- 8.5.5 BellSouth will provide the circuit between the Parties' respective Frame Relay Switches. The Parties will be compensated as follows: BellSouth will invoice, and Clearwave Communications will pay, the total nonrecurring and recurring charges for the circuit based upon the rates set forth in BellSouth's Interstate Access Tariff, FCC No. 1. Clearwave Communications will then invoice, and BellSouth will pay, an amount calculated by multiplying the BellSouth billed charges for the circuit by one-half of Clearwave Communications's PLCU.
- 8.6 The Parties agree to compensate each other for Frame Relay network-to-network interface (NNI) ports based upon the NNI rates set forth in BellSouth's Interstate Access Tariff, FCC No. 1. Compensation for each pair of NNI ports will be calculated as follows: BellSouth will invoice, and Clearwave Communications will pay, the total nonrecurring and recurring charges for the NNI port. Clearwave Communications will then invoice, and BellSouth will pay, an amount calculated by multiplying the BellSouth billed nonrecurring and recurring charges for the NNI port by Clearwave Communications's PLCU.
- 8.7 Each Party agrees that there will be no charges to the other Party for its own subscriber's Permanent Virtual Circuit (PVC) rate elements for the local PVC segment from its Frame Relay switch to its own subscriber's premises. PVC rate elements include the Data Link Connection Identifier (DLCI) and Committed Information Rate (CIR).
- 8.8 For the PVC segment between the Clearwave Communications and BellSouth Frame Relay switches, compensation for the PVC charges is based upon the rates in BellSouth's Interstate Access Tariff, FCC No. 1.
- 8.9 Compensation for PVC rate elements will be calculated as follows:
- 8.9.1 If Clearwave Communications orders a VC connection between a BellSouth subscriber's PVC segment and a PVC segment from the BellSouth Frame Relay switch to the Clearwave Communications Frame Relay switch, BellSouth will

invoice, and Clearwave Communications will pay, the total nonrecurring and recurring PVC charges for the PVC segment between the BellSouth and Clearwave Communications Frame Relay switches. If the VC is a Local VC, Clearwave Communications will then invoice and BellSouth will pay, the total nonrecurring and recurring PVC charges billed for that segment. If the VC is not local, no compensation will be paid to Clearwave Communications for the PVC segment.

- 8.9.2 If BellSouth orders a Local VC connection between a Clearwave Communications subscriber's PVC segment and a PVC segment from the Clearwave Communications Frame Relay switch to the BellSouth Frame Relay switch, BellSouth will invoice, and Clearwave Communications will pay, the total nonrecurring and recurring PVC and CIR charges for the PVC segment between the BellSouth and Clearwave Communications Frame Relay switches. If the VC is a Local VC, Clearwave Communications will then invoice and BellSouth will pay the total nonrecurring and recurring PVC and CIR charges billed for that segment. If the VC is not local, no compensation will be paid to Clearwave Communications for the PVC segment.
- 8.9.3 The Parties agree to compensate each other for requests to change a PVC segment or PVC service order record, according to the Feature Change charge as set forth in the BellSouth access tariff BellSouth Tariff FCC No. 1.
- 8.9.4 If Clearwave Communications requests a change, BellSouth will invoice and Clearwave Communications will pay a Feature Change charge for each affected PVC segment.
- 8.9.4.1 If BellSouth requests a change to a Local VC, Clearwave Communications will invoice and BellSouth will pay a Feature Change charge for each affected PVC segment.
- 8.9.5 The Parties agree to limit the sum of the CIR for the VCs on a DS1 NNI port to not more than three times the port speed, or not more than six times the port speed on a DS3 NNI port.
- 8.9.6 Except as expressly provided herein, this Agreement does not address or alter in any way either Party's provision of Exchange Access Frame Relay Service, Managed Shared Frame Relay Service or interLATA Frame Relay Service. All charges by each Party to the other for carriage of Exchange Access Frame Relay Service or interLATA Frame Relay Service are included in the BellSouth access tariff BellSouth Tariff FCC No. 1.
- 8.10 Clearwave Communications will identify and report quarterly to BellSouth the PLCU of the Frame Relay facilities it uses, per Section 8.5.3 above.

8.11 Either Party may request a review or audit of the various service components, consistent with the provisions of section E2 of the BellSouth State Access Services tariffs or Section 2 of the BellSouth FCC No.1 Tariff.

**9. ORDERING CHARGES**

9.1 The terms, conditions and rates for Ordering Charges are as set forth in FCC Tariff for Access Service Records.

Exhibit B

# Basic Architecture

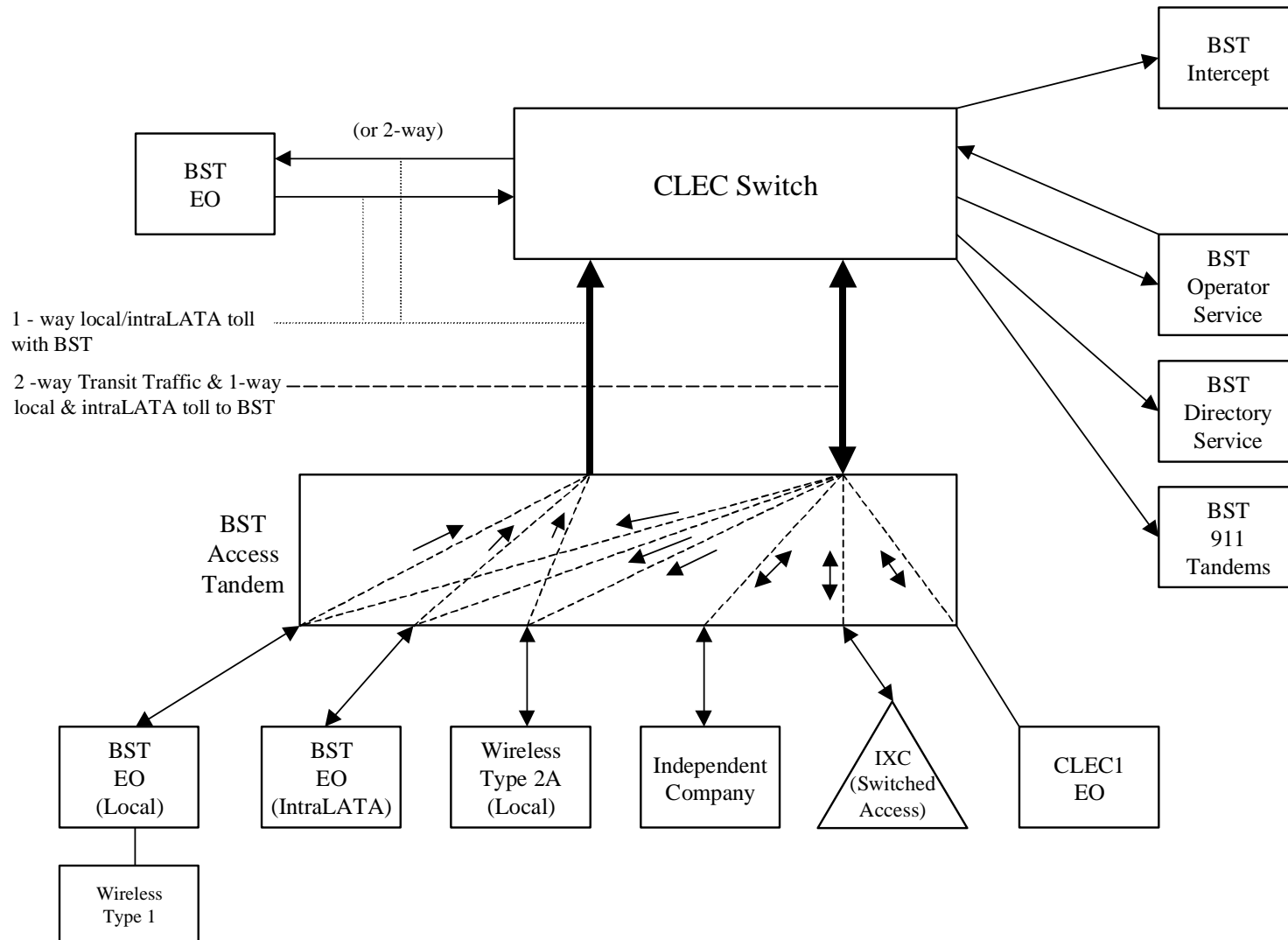

# One-Way Architecture

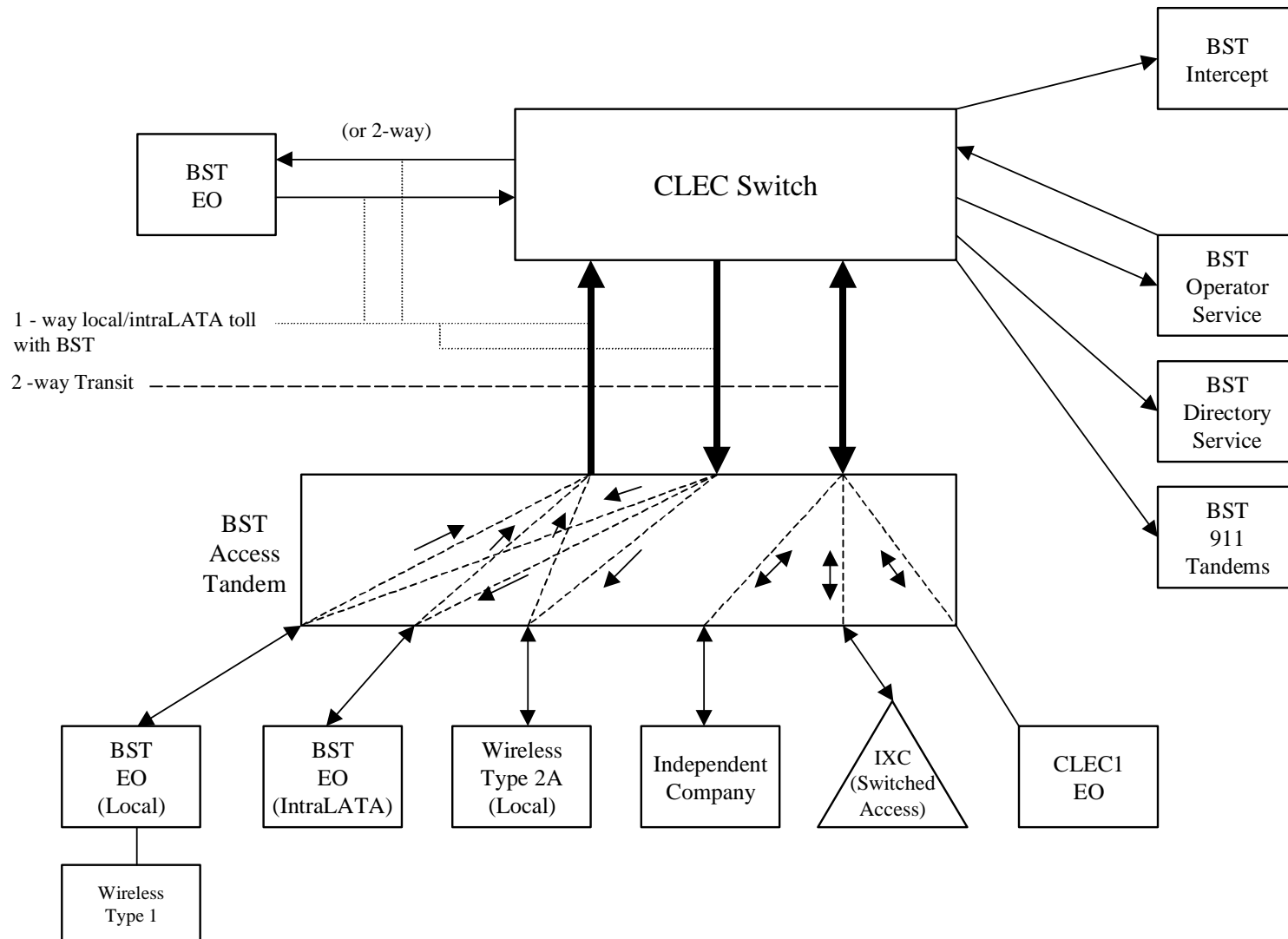



Exhibit D

# Two-Way Architecture

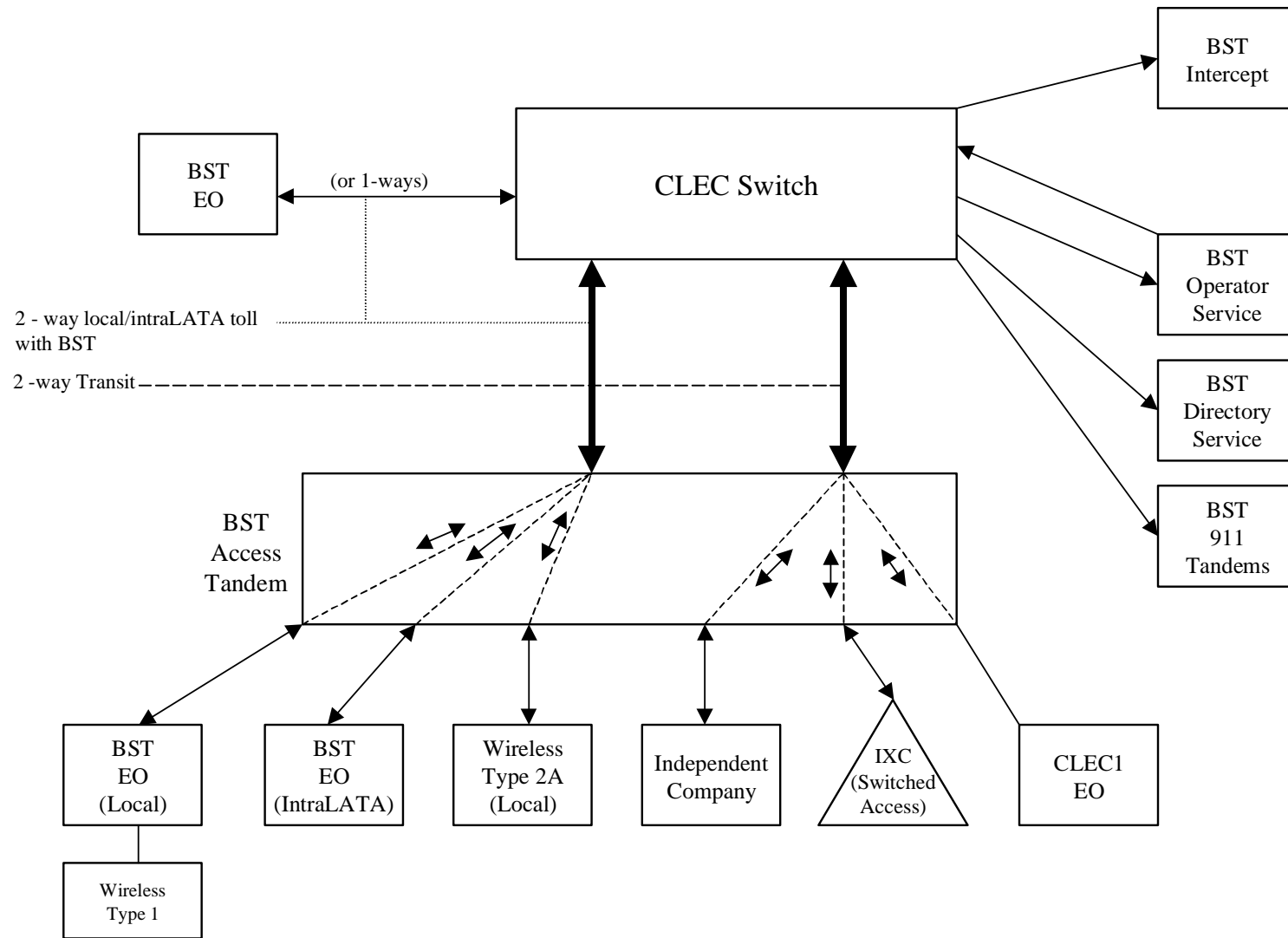
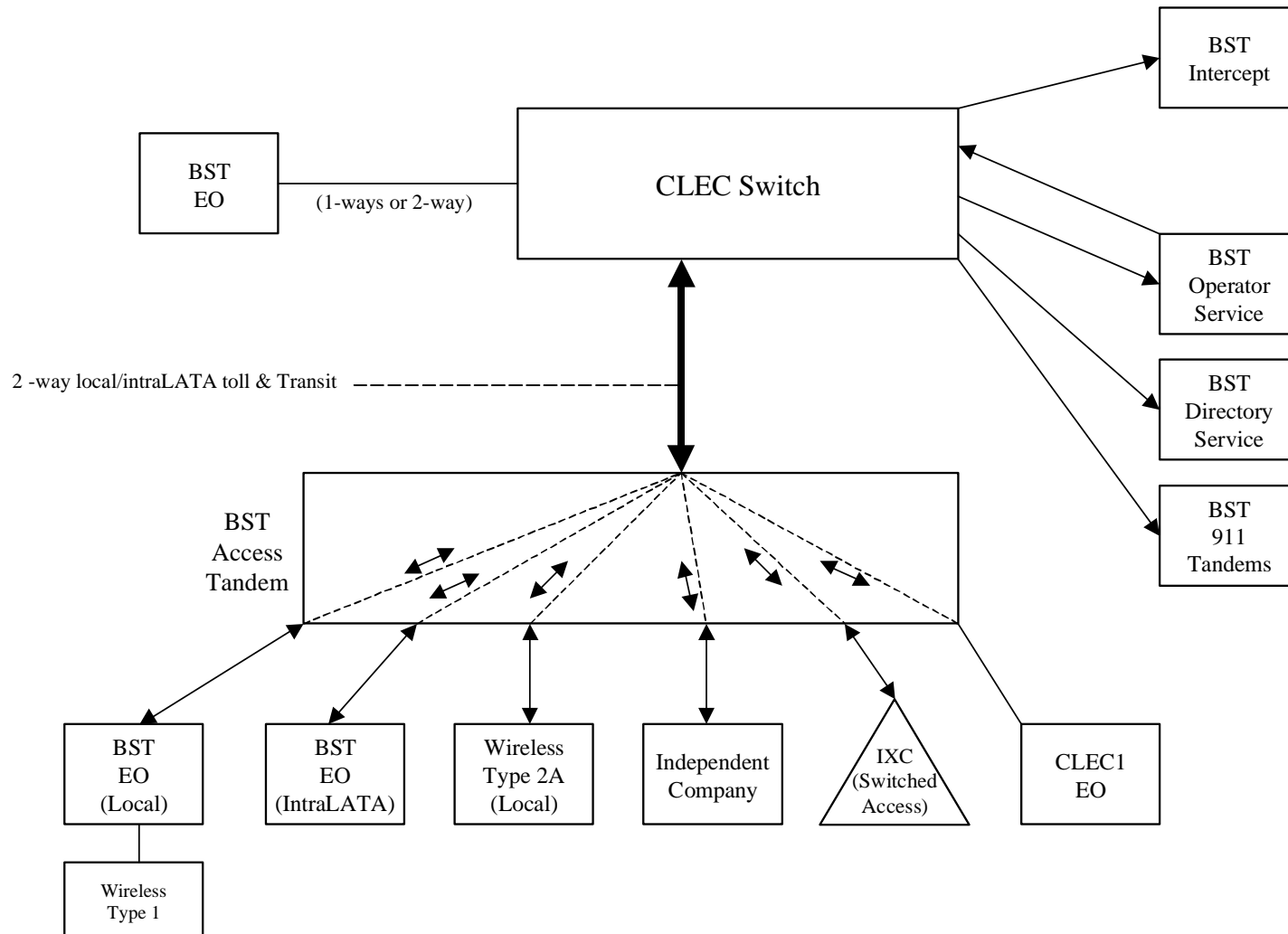

Exhibit E

# Supergroup Architecture



LOCAL INTERCONNECTION - Kentucky							Attachment: 3		Exhibit: A						
CATEGORY	RATE ELEMENTS	Interim	Zone	BCS	USOC	RATES (\$)	Svc Order Submitted Elec per LSR	Svc Order Submitted Manually per LSR	Incremental Charge - Manual Svc Order vs. Electronic-1st	Incremental Charge - Manual Svc Order vs. Electronic-Add'l	Incremental Charge - Manual Svc Order vs. Electronic-Disc 1st	Incremental Charge - Manual Svc Order vs. Electronic-Disc Add'l			
													Rec	Nonrecurring	
										SOMEc	SOMAN	SOMAN	SOMAN	SOMAN	SOMAN
<b>LOCAL INTERCONNECTION (CALL TRANSPORT AND TERMINATION)</b>															
NOTE: "bk" beside a rate indicates that the Parties have agreed to bill and keep for that element pursuant to the terms and conditions in Attachment 3.															
<b>TANDEM SWITCHING</b>															
	Tandem Switching Function Per MOU			OHD		0.0006772bk									
	Multiple Tandem Switching, per MOU (applies to intial tandem only)			OHD		0.0006772									
	Tandem Intermediary Charge, per MOU*			OHD		0.0015									
* This charge is applicable only to transit traffic and is applied in addition to applicable switching and/or interconnection charges.															
<b>TRUNK CHARGE</b>															
	Installation Trunk Side Service - per DS0			OHD	TPP++		21.58	8.13							
	Dedicated End Office Trunk Port Service-per DS0**			OHD	TDE0P	0.00									
	Dedicated End Office Trunk Port Service-per DS1**			OH1 OH1MS	TDE1P	0.00									
	Dedicated Tandem Trunk Port Service-per DS0**			OHD	TDW0P	0.00									
	Dedicated Tandem Trunk Port Service-per DS1**			OH1 OH1MS	TDW1P	0.00									
** This rate element is recovered on a per MOU basis and is included in the End Office Switching and Tandem Switching, per MOU rate elements															
<b>COMMON TRANSPORT (Shared)</b>															
	Common Transport - Per Mile, Per MOU			OHD		0.0000030bk									
	Common Transport - Facilities Termination Per MOU			OHD		0.0007466bk									
<b>LOCAL INTERCONNECTION (DEDICATED TRANSPORT)</b>															
<b>INTEROFFICE CHANNEL - DEDICATED TRANSPORT</b>															
	Interoffice Channel - Dedicated Transport - 2-Wire Voice Grade - Per Mile per month			OHL, OHM	1L5NF	0.01									
	Interoffice Channel - Dedicated Transport- 2- Wire Voice Grade - Facility Termination per month			OHL, OHM	1L5NF	29.11	47.34	31.78	22.77	8.75					
	Interoffice Channel - Dedicated Transport - 56 kbps - per mile per month			OHL, OHM	1L5NK	0.0115									
	Interoffice Channel - Dedicated Transport - 56 kbps - Facility Termination per month			OHL, OHM	1L5NK	20.97	47.35	31.78	22.77	8.75					
	Interoffice Channel - Dedicated Transport - 64 kbps - per mile per month			OHL, OHM	1L5NK	0.0115									
	Interoffice Channel - Dedicated Transport - 64 kbps - Facility Termination per month			OHL, OHM	1L5NK	20.97	47.35	31.78	22.77	8.75					
	Interoffice Channel - Dedicated Channel - DS1 - Per Mile per month			OH1, OH1MS	1L5NL	0.23									
	Interoffice Channel - Dedicated Transport - DS1 - Facility Termination per month			OH1, OH1MS	1L5NL	96.04	105.52	98.46	23.09	20.49					
	Interoffice Channel - Dedicated Transport - DS3 - Per Mile per month			OH3, OH3MS	1L5NM	4.97									
	Interoffice Channel - Dedicated Transport - DS3 - Facility Termination per month			OH3, OH3MS	1L5NM	1,175.15	335.40	219.24	89.57	87.75					
<b>LOCAL CHANNEL - DEDICATED TRANSPORT</b>															
	Local Channel - Dedicated - 2-Wire Voice Grade per month			OHL, OHM	TEFV2	18.57	265.78	46.96	46.79	4.98					
	Local Channel - Dedicated - 4-Wire Voice Grade per month			OHL, OHM	TEFV4	19.86	266.48	47.65	47.54	5.73					
	Local Channel - Dedicated - DS1 per month			OH1	TEFHG	40.46	209.60	176.51	30.21	21.07					
	Local Channel - Dedicated - DS3 Facility Termination per month			OH3	TEFHJ	576.05	551.38	338.08	173.00	120.42					
<b>LOCAL INTERCONNECTION MID-SPAN MEET</b>															
NOTE: If Access service ride Mid-Span Meet, one-half the tariffed service Local Channel rate is applicable.															
	Local Channel - Dedicated - DS1 per month			OH1MS	TEFHG	0.00	0.00								
	Local Channel - Dedicated - DS3 per month			OH3MS	TEFHJ	0.00	0.00								
<b>MULTIPLEXERS</b>															
	Channelization - DS1 to DS0 Channel System			OH1, OH1MS	SATN1	113.33	101.40	71.60	13.79	13.04					
	DS3 to DS1 Channel System per month			OH3, OH3MS	SATNS	158.20	199.23	118.62	50.16	48.59					
	DS3 Interface Unit (DS1 COC) per month			OH1, OH1MS	SATCO	11.80	10.07	7.08							
Notes: If no rate is identified in the contract, the rates, terms, and conditions for the specific service or function will be as set forth in applicable BellSouth tariff.															

**Attachment 4**  
**Physical Collocation**

**BELLSOUTH**  
**PHYSICAL COLLOCATION**

**1. Scope of Attachment**

- 1.1 The rates, terms, and conditions contained within this Attachment shall only apply when Clearwave Communications is physically collocated as a sole occupant or as a Host within a BellSouth Premises location pursuant to this Attachment. BellSouth Premises include BellSouth Central Offices and Serving Wire Centers (hereinafter "Premises"). This Attachment is applicable to Premises owned or leased by BellSouth. However, if the Premises occupied by BellSouth is leased by BellSouth from a third party, special considerations and intervals may apply in addition to the terms and conditions contained in this Attachment.
- 1.2 Right to Occupy. BellSouth shall offer to Clearwave Communications collocation on rates, terms, and conditions that are just, reasonable, non-discriminatory and consistent with the rules of the FCC. Subject to the rates, terms and conditions of this Attachment, where space is available and it is technically feasible, BellSouth will allow Clearwave Communications to occupy a certain area designated by BellSouth within a Premises, or on BellSouth property upon which the Premises is located, of a size which is specified by Clearwave Communications and agreed to by BellSouth (hereinafter "Collocation Space"). The necessary rates, terms and conditions for h premises as defined by the FCC, other than BellSouth Premises, shall be negotiated upon reasonable request for collocation at such premises.
- 1.2.1 Neither BellSouth nor any of BellSouth's affiliates may reserve space for future use on more preferential terms than those set forth in this Attachment.
- 1.2.1.1 In all states other than Florida, the size specified by Clearwave Communications may contemplate a request for space sufficient to accommodate Clearwave Communications's growth within a twenty-four (24) month period.
- 1.2.1.2 In the state of Florida, the size specified by Clearwave Communications may contemplate a request for space sufficient to accommodate Clearwave Communications's growth within an eighteen (18) month period.
- 1.3 Space Allocation. BellSouth shall attempt to accommodate Clearwave Communications's requested preferences, if any. In allocating Collocation Space, BellSouth shall not materially increase Clearwave Communications's cost or materially delay Clearwave Communications's occupation and use of the Collocation Space, assign Collocation Space that will impair the quality of service or otherwise limit the service Clearwave Communications wishes to offer, reduce unreasonably the total space available for physical collocation or preclude unreasonable physical collocation within the Premises. Space shall not be available for collocation if it is: (a) physically occupied by non-obsolete equipment; (b) assigned to another collocated

telecommunications carrier; (c) used to provide physical access to occupied space; (d) used to enable technicians to work on equipment located within occupied space; (e) properly reserved for future use, either by BellSouth or another collocated telecommunications carrier; or (f) essential for the administration and proper functioning of Premises. BellSouth may segregate Collocation Space and require separate entrances for collocated telecommunications carriers to access their Collocation Space, pursuant to FCC Rules.

- 1.4 **Space Reclamation.** In the event of space exhaust within a Premises, BellSouth may include in its documentation for the Petition for Waiver filed with the Commission, any unutilized space in the Premises. Clearwave Communications will be responsible for the justification of unutilized space within its Collocation Space, if the Commission requires such justification.
- 1.5 **Use of Space.** Clearwave Communications shall use the Collocation Space for the purposes of installing, maintaining and operating Clearwave Communications's equipment (to include testing and monitoring equipment) necessary for interconnection with BellSouth services and facilities or for accessing BellSouth unbundled network elements for the provision of telecommunications services, as specifically set forth in this Agreement. The Collocation Space assigned to Clearwave Communications may not be used for any purposes other than as specifically described herein or in any amendment hereto.
- 1.6 **Rates and Charges.** Clearwave Communications agrees to pay the rates and charges identified in Exhibit B attached hereto.
- 1.7 If any due date contained in this Attachment falls on a weekend or National holiday, the due date will be the next business day thereafter. For intervals of ten (10) calendar days or less, National holidays will be excluded.
- 1.8 The Parties agree to comply with all applicable federal, state, county, local and administrative laws, rules, ordinances, regulations and codes in the performance of their obligations hereunder.
2. **Space Availability Report**
- 2.1 **Space Availability Report.** Upon request from Clearwave Communications and at the Clearwave Communications's expense, BellSouth will provide a written report (Space Availability Report) describing in detail the space that is available for collocation at a particular Premises. This report will include the amount of Collocation Space available at the Premises requested, the number of collocators present at the Premises, any modifications in the use of the space since the last report on the Premises requested and the measures BellSouth is taking to make additional space available for collocation arrangements. A Space Availability Report does not reserve space at the Premises for which the Space Availability Report was requested by Clearwave Communications.

- 2.1.1 The request from Clearwave Communications for a Space Availability Report must be in writing and include the Premises street address, as identified in the Local Exchange Routing Guide (LERG) and Common Language Location Identification (CLLI) code of the Premises. CLLI code information is located in the National Exchange Carrier Association (NECA) Tariff FCC No. 4.
- 2.1.2 BellSouth will respond to a request for a Space Availability Report for a particular Premises within ten (10) calendar days of the receipt of such a request. BellSouth will make its best efforts to respond in ten (10) calendar days to a Space Availability Report request when the request includes from two (2) to five (5) Premises within the same state. The response time for Space Availability Report requests of more than five (5) Premises shall be negotiated between the Parties. If BellSouth cannot meet the ten (10) calendar day response time, BellSouth shall notify Clearwave Communications and inform Clearwave Communications of the timeframe under which it can respond.

### **3. Collocation Options**

- 3.1 Cageless. BellSouth shall allow Clearwave Communications to collocate Clearwave Communications's equipment and facilities without requiring the construction of a cage or similar structure. BellSouth shall allow Clearwave Communications to have direct access to Clearwave Communications's equipment and facilities in accordance with Section 5.9. BellSouth shall make cageless collocation available in single bay increments. Except where Clearwave Communications's equipment requires special technical considerations (e.g., special cable racking or isolated ground plane), BellSouth shall assign cageless Collocation Space in conventional equipment rack lineups where feasible. For equipment requiring special technical considerations, Clearwave Communications must provide the equipment layout, including spatial dimensions for such equipment pursuant to generic requirements contained in Telcordia GR-63-Core, and shall be responsible for compliance with all special technical requirements associated with such equipment.
- 3.2 Caged. At Clearwave Communications's expense, Clearwave Communications will arrange with a Supplier certified by BellSouth (BellSouth Certified Supplier) to construct a collocation arrangement enclosure in accordance with BellSouth's Technical References (TRs) (Specifications) prior to starting equipment installation. BellSouth will provide Specifications upon request. Where local building codes require enclosure specifications more stringent than BellSouth's enclosure Specifications, Clearwave Communications and Clearwave Communications's BellSouth Certified Supplier must comply with the more stringent local building code requirements. Clearwave Communications's BellSouth Certified Supplier shall be responsible for filing and receiving any and all necessary permits and/or licenses for such construction. BellSouth shall cooperate with Clearwave Communications and provide, at Clearwave Communications's expense, the documentation, including

existing building architectural drawings, enclosure drawings, and Specifications required and necessary for Clearwave Communications's BellSouth Certified Supplier to obtain the zoning, permits and/or other licenses. Clearwave Communications's BellSouth Certified Supplier shall bill Clearwave Communications directly for all work performed for Clearwave Communications pursuant to this Attachment. BellSouth shall have no liability for, nor responsibility to pay, such charges imposed by Clearwave Communications's BellSouth Certified Supplier. Clearwave Communications must provide the local BellSouth Central Office building contact with two Access Keys that will allow entry into the locked enclosure. Except in the case of an emergency, BellSouth will not access Clearwave Communications's locked enclosure prior to notifying Clearwave Communications at least forty-eight (48) hours or two (2) business days, whichever is greater, before access to the Collocation Space is required. Upon request, BellSouth shall construct the enclosure for Clearwave Communications.

- 3.2.1 BellSouth may elect to review Clearwave Communications's plans and specifications prior to allowing construction to start, to ensure compliance with BellSouth's Specifications. BellSouth will notify Clearwave Communications of its desire to execute this review in BellSouth's response to the Initial Application, if Clearwave Communications has indicated its desire to construct its own enclosure. If Clearwave Communications's Initial Application does not indicate its desire to construct its own enclosure, but its subsequent firm order does indicate its desire to construct its own enclosure, then notification to review will be given within ten (10) calendar days after the Firm Order date. BellSouth shall complete its review within fifteen (15) calendar days after the receipt of Clearwave Communications's plans and specifications. Regardless of whether or not BellSouth elects to review Clearwave Communications's plans and specifications, BellSouth reserves the right to inspect the enclosure after construction has been completed to ensure that it is constructed according to Clearwave Communications's submitted plans and specifications and/or BellSouth's Specifications, as applicable. If BellSouth decides to inspect the constructed Collocation Space, BellSouth will complete its inspection within fifteen (15) calendar days after receipt of written notification of completion of the enclosure from Clearwave Communications. BellSouth shall require Clearwave Communications to remove or correct within seven (7) calendar days, at Clearwave Communications's expense, any structure that does not meet Clearwave Communications's plans and specifications or BellSouth's Specifications, if applicable.

- 3.3 Shared Caged Collocation. Clearwave Communications may allow other telecommunications carriers to share Clearwave Communications's caged collocation arrangement, pursuant to the terms and conditions agreed to by Clearwave Communications (Host) and the other telecommunications carriers (Guests) pursuant to this Section, except where the Premises is located within a leased space and BellSouth is prohibited by said lease from offering such an option to Clearwave Communications. BellSouth shall be notified in writing by Clearwave Communications upon the execution of any agreement between the Host and its Guest(s) within ten (10) calendar days of its execution and prior to the submission of



- any Firm Orders. Further, such notification shall include the name of the Guest(s), the term of the agreement, and a certification by Clearwave Communications that said agreement imposes upon the Guest(s) the same terms and conditions for Collocation Space as set forth in this Attachment between BellSouth and Clearwave Communications.
- 3.3.1 Clearwave Communications, as the Host, shall be the sole interface and responsible Party to BellSouth for the assessment and billing of rates and charges contained within this Attachment and for the purposes of ensuring that the safety and security requirements of this Attachment are fully complied with by the Guest(s), its employees and agents. BellSouth shall provide Clearwave Communications with a proration of the costs of the Collocation Space based on the number of collocators and the space used by each, with a minimum charge of one (1) bay/rack per Host/Guest. In all states other than Florida, and in addition to the above, Clearwave Communications shall be the responsible party to BellSouth for the purpose of submitting applications for initial and additional equipment placement for the Guest(s). In Florida, the Guest(s) may submit its own initial and additional equipment placement applications using the Host's Access Carrier Name Abbreviation (ACNA). A separate Guest application shall result in the assessment of an Initial Application Fee or a Subsequent Application Fee, as set forth in Exhibit B, which will be billed to the Host on the date that BellSouth provides its written response to the Guest(s) Bona Fide Application (Application Response).
- 3.3.2 Notwithstanding the foregoing, the Guest(s) may submit service orders directly to BellSouth to request the provisioning of interconnecting facilities between BellSouth and the Guest(s), the provisioning of services, and access to unbundled network elements. The bill for these interconnecting facilities, services and access to UNEs will be charged to the Guest(s) pursuant to the applicable Tariff or the Guest's Interconnection Agreement with BellSouth.
- 3.3.3 Clearwave Communications shall indemnify and hold harmless BellSouth from any and all claims, actions, causes of action, of whatever kind or nature arising out of the presence of Clearwave Communications's Guest(s) in the Collocation Space, except to the extent caused by BellSouth's sole negligence, gross negligence, or willful misconduct.
- 3.4 Adjacent Collocation. Subject to technical feasibility and space availability, BellSouth will permit an adjacent collocation arrangement (Adjacent Arrangement) on Premises' property only when space within the Premises is legitimately exhausted and where the Adjacent Arrangement does not interfere with access to existing or planned structures or facilities on the Premises' property. An Adjacent Arrangement shall be constructed or procured by Clearwave Communications and must be in conformance with BellSouth's design and construction Specifications. Further, Clearwave Communications shall construct, procure, maintain and operate said Adjacent Arrangement(s) pursuant to all of the rates, terms and conditions set forth in this Attachment.

- 3.4.1 If Clearwave Communications requests Adjacent Collocation, pursuant to the conditions stated in 3.4 above, Clearwave Communications must arrange with a BellSouth Certified Supplier to construct the Adjacent Arrangement structure in accordance with BellSouth's Specifications. BellSouth will provide Specifications upon request. Where local building codes require enclosure specifications more stringent than BellSouth's Specifications, Clearwave Communications and Clearwave Communications's BellSouth Certified Supplier must comply with the more stringent local building code requirements. Clearwave Communications's BellSouth Certified Supplier shall be responsible for filing and receiving any and all necessary zoning, permits and/or licenses for such construction. Clearwave Communications's BellSouth Certified Supplier shall bill Clearwave Communications directly for all work performed for Clearwave Communications pursuant to this Attachment. BellSouth shall have no liability for, nor responsibility to pay, such charges imposed by Clearwave Communications's BellSouth Certified Supplier. Clearwave Communications must provide the local BellSouth Central Office building contact with two cards, keys or other access devices used to gain entry into the locked enclosure. Except in the case of an emergency, BellSouth will not access Clearwave Communications's locked enclosure prior to notifying Clearwave Communications at least forty-eight (48) hours or two (2) business days, whichever is greater, before access to the Collocation Space is required.
- 3.4.2 Clearwave Communications must submit its Adjacent Arrangement construction plans and specifications to BellSouth when it places its Firm Order. BellSouth shall review Clearwave Communications's plans and specifications prior to construction of an Adjacent Arrangement(s) to ensure Clearwave Communications's compliance with BellSouth's Specifications. BellSouth shall complete its review within fifteen (15) calendar days after receipt of the plans and specifications from Clearwave Communications for the Adjacent Arrangement. BellSouth may inspect the Adjacent Arrangement during and after construction is completed to ensure that it is constructed according to Clearwave Communications's submitted plans and specifications. If BellSouth decides to inspect the completed Adjacent Arrangement, BellSouth will complete its inspection within fifteen (15) calendar days after receipt of written notification of completion of the enclosure from Clearwave Communications. BellSouth shall require Clearwave Communications to remove or correct within seven (7) calendar days at Clearwave Communications's expense, any structure that does not meet its submitted plans and specifications or BellSouth's Specifications, if applicable.
- 3.4.3 Clearwave Communications shall provide a concrete pad, the structure housing the arrangement, heating/ventilation/air conditioning (HVAC), lighting, and all of the facilities that are required to connect the structure (i.e., racking, conduits, etc.) to the BellSouth point of demarcation. At Clearwave Communications's option, and where the local authority having jurisdiction permits, BellSouth shall provide an AC power source and access to physical collocation services and facilities, subject to the same nondiscriminatory requirements as those applicable to any other physical collocation arrangement. In Alabama and Louisiana, BellSouth will provide DC power to Adjacent Collocation sites where technically feasible, as that term has been defined by

the FCC subject to individual case basis pricing. Clearwave Communications's BellSouth Certified Supplier shall be responsible, at Clearwave Communications's sole expense, for filing and receiving any and all necessary zoning, permits and/or licenses for an Adjacent Arrangement. BellSouth shall allow Shared Caged Collocation within an Adjacent Arrangement, pursuant to the terms and conditions set forth in 3.3 above.

- 3.5 Co-Carrier Cross Connect (CCXC). The primary purpose of collocation is for a telecommunications carrier to interconnect with BellSouth's network or to access BellSouth's unbundled network elements for the provision of telecommunications services. BellSouth will permit Clearwave Communications to interconnect between its virtual or physical collocation arrangements and those of another collocated telecommunications carrier within the same Premises. Both Clearwave Communications's agreement and the other collocated telecommunications carrier's agreement must contain rates, terms and conditions for CCXC language. Clearwave Communications is prohibited from using the Collocation Space for the sole or primary purpose of cross connecting to other collocated telecommunications carriers.
- 3.5.1 Clearwave Communications must contract with a BellSouth Certified Supplier to place the CCXC. The CCXC shall be provisioned through facilities owned by Clearwave Communications. Such connections to other collocated telecommunications carriers may be made using either optical or electrical facilities. In cases where Clearwave Communications's equipment and the equipment of the other collocated telecommunications carrier are located in contiguous caged Collocation Spaces, Clearwave Communications may use its own technicians to install co-carrier cross connects using either electrical or optical facilities between the equipment of both collocated telecommunications carriers and construct a dedicated cable support structure between the two contiguous cages. Clearwave Communications shall deploy such optical or electrical connections directly between its own facilities and the facilities of another collocated telecommunications carrier without being routed through BellSouth's equipment. Clearwave Communications shall not provision CCXC on any BellSouth distribution frame, POT (Point of Termination) Bay, DSX (Digital System Cross-connect) or LGX (Light Guide Cross-connect). Clearwave Communications is responsible for ensuring the integrity of the signal.
- 3.5.2 Clearwave Communications shall be responsible for providing a letter of authorization (LOA), with the application, to BellSouth from the other collocated telecommunications carrier to which it will be cross-connecting. Clearwave Communications-provisioned CCXC shall utilize common cable support structure. There will be a recurring charge per linear foot, per cable, of common cable support structure used. In the case of two contiguous caged collocation arrangements, Clearwave Communications may use its own technicians to construct the dedicated support structure between the two collocation arrangements.
- 3.5.3 To order CCXCs, Clearwave Communications must submit an Initial Application or Subsequent Application to BellSouth. If no modification to the Collocation Space is requested other than the placement of CCXCs, the Subsequent Application Fee for

CCXCs, as defined in Exhibit B, will apply. If modifications, in addition to the placement of CCXCs, are requested, the Initial Application or Subsequent Application Fee will apply. BellSouth will bill this nonrecurring fee on the date that it provides an Application Response to Clearwave Communications.

#### **4. Occupancy**

4.1 Occupancy. BellSouth will notify Clearwave Communications in writing when the Collocation Space is ready for occupancy (Space Ready Date). Clearwave Communications will schedule and complete an acceptance walkthrough of the Collocation Space with BellSouth within fifteen (15) calendar days of the Space Ready Date. BellSouth will correct any deviations in Clearwave Communications's original or jointly amended application requirements within seven (7) calendar days after the walkthrough, unless the Parties jointly agree upon a different time frame. BellSouth will also establish a new Space Ready Date. Another acceptance walkthrough will then be scheduled and conducted within fifteen (15) calendar days of the new Space Ready Date. This follow-up acceptance walkthrough will be limited to only those items identified in the initial walkthrough. If Clearwave Communications completes its acceptance walkthrough within the fifteen (15) calendar day interval, billing will begin upon the date of Clearwave Communications's acceptance of the Collocation Space (Space Acceptance Date). In the event that Clearwave Communications fails to complete an acceptance walkthrough within this fifteen (15) calendar day interval, the Collocation Space shall be deemed accepted by Clearwave Communications on the Space Ready Date and billing will commence from that date. If Clearwave Communications decides to occupy the space prior to the Space Ready Date, the date Clearwave Communications occupies the space becomes the new Space Acceptance Date and billing will begin from that date. Clearwave Communications must notify BellSouth in writing that collocation equipment installation is complete and operational with BellSouth's network. BellSouth may, at its discretion, refuse to accept orders for cross connects until it has received such notice. For the purposes of this paragraph, Clearwave Communications's telecommunications equipment will be deemed operational when it has been cross-connected to BellSouth's network for the purpose of provisioning telecommunication services to its customers.

4.2 Termination of Occupancy. In addition to any other provisions addressing termination of occupancy in this Agreement, Clearwave Communications may terminate occupancy in a particular Collocation Space by submitting a Subsequent Application requesting termination of occupancy. Such termination shall be effective upon BellSouth's acceptance of the Space Relinquishment Form. Billing for monthly recurring charges will cease on the date that Clearwave Communications and BellSouth conduct an inspection of the terminated space and jointly sign off on the Space Relinquishment Form or on the date that Clearwave Communications signs off on the Space Relinquishment Form and sends this form to BellSouth, if a subsequent inspection of the terminated space by BellSouth reveals no discrepancies. If the subsequent inspection by BellSouth does reveal discrepancies, billing will cease on the date that BellSouth and Clearwave Communications jointly conduct an inspection,

which confirms that Clearwave Communications has corrected all of the noted discrepancies. A Subsequent Application Fee will not apply for the termination of occupancy. BellSouth may terminate Clearwave Communications's right to occupy the Collocation Space in the event that Clearwave Communications fails to comply with any provision of this Agreement, including the payment of the applicable fees.

- 4.2.1 Upon termination of occupancy, Clearwave Communications, at its sole expense, shall remove its equipment and any other property from the Collocation Space. Clearwave Communications shall have thirty (30) calendar days from the Bona Fide Firm Order (BFFO) Subsequent Application date (Termination Date) to complete such removal, including the removal of all equipment and facilities of Clearwave Communications's Guest(s), unless Clearwave Communications's Guest(s) has assumed responsibility for the Collocation Space housing the Guest(s)'s equipment and executed the appropriate documentation required by BellSouth prior to the Clearwave Communications removal date. Clearwave Communications shall continue the payment of all monthly fees to BellSouth until the date that Clearwave Communications, and if applicable Clearwave Communications's Guest(s), has fully vacated the Collocation Space and the Space Relinquishment Form has been accepted by BellSouth. Should Clearwave Communications or Clearwave Communications's Guest(s) fail to vacate the Collocation Space within thirty (30) calendar days from the Termination Date, BellSouth shall have the right to remove the equipment and dispose of the equipment and other property of Clearwave Communications or Clearwave Communications's Guest(s), in any manner that BellSouth deems fit, at Clearwave Communications's expense and with no liability whatsoever for Clearwave Communications's property or Clearwave Communications's Guest(s)'s property. Upon termination of Clearwave Communications's right to occupy specific Collocation Space, the Collocation Space will revert back to BellSouth's space inventory, and Clearwave Communications shall surrender the Collocation Space to BellSouth in the same condition as when it was first occupied by Clearwave Communications, with the exception of ordinary wear and tear, unless otherwise agreed to by the Parties. Clearwave Communications's BellSouth Certified Supplier shall be responsible for updating and making any necessary changes to BellSouth's records as required by BellSouth's Specifications including, but not limited to, Central Office Record Drawings and ERMA Records. Clearwave Communications shall be responsible for the cost of removing any Clearwave Communications constructed enclosure, together with any supporting structures (e.g., racking, conduits, or power cables), at the termination of occupancy and restoring the grounds to their original condition.

## **5. Use of Collocation Space**

- 5.1 Equipment Type. BellSouth permits the collocation of any equipment necessary for interconnection to BellSouth's network or access to BellSouth's unbundled network elements in the provision of telecommunications services, as the term "necessary" is defined by FCC 47 C.F.R. Section 51.323 (b). The primary purpose and function of any equipment collocated in a Premises must be for interconnection to BellSouth's

- network or access to BellSouth's unbundled network elements in the provision of telecommunications services.
- 5.1.1 Examples of equipment that would not be considered necessary include, but are not limited to: traditional circuit switching equipment, equipment used exclusively for call-related databases, computer servers used exclusively for providing information services, operations support system (OSS) equipment used to support collocated telecommunications carrier network operations, equipment that generates customer orders, manages trouble tickets or inventory, or stores customer records in centralized databases, etc. BellSouth will determine upon receipt of an application if the requested equipment is necessary based on the criteria established by the FCC. Multifunctional equipment placed on Premises must not place any greater relative burden on BellSouth's property than comparable single-function equipment. BellSouth reserves the right to permit collocation of any equipment on a nondiscriminatory basis.
  - 5.1.2 Such equipment must, at a minimum, meet the following Telcordia Network Equipment Building Systems (NEBS) General Equipment Requirements: Criteria Level 1 requirements as outlined in Telcordia Special Report SR-3580, Issue 1. Except where otherwise required by a Commission, BellSouth shall comply with the applicable FCC rules relating to denial of collocation based on Clearwave Communications's failure to comply with this Section.
  - 5.1.3 Clearwave Communications shall not request more DS0, DS1, DS3 and optical terminations for a collocation arrangement than the total port or termination capacity of the equipment physically installed in the arrangement. The total capacity of the equipment collocated in the arrangement will include equipment contained in an application, as well as equipment already placed in the collocation arrangement. If full network termination capacity of the equipment being installed is not requested in the application, additional network terminations for the installed equipment will require the submission of another application. In the event Clearwave Communications submits an application for terminations that will exceed the total capacity of the collocated equipment, Clearwave Communications will be informed of the discrepancy by BellSouth and required to submit a revision to the application.
  - 5.2 Clearwave Communications shall notify BellSouth whenever Clearwave Communications submits a Method of Procedure (MOP) adding equipment to Clearwave Communications's Collocation Space and shall provide to BellSouth a list of all UCC-1 lien holders or other entities that have a financial interest, secured or otherwise, in the equipment in Clearwave Communications's Collocation Space. Clearwave Communications shall submit a list of any lien holders or other entities that have a financial interest in the equipment that is collocated by Clearwave Communications to its RCM Representative.
  - 5.3 Clearwave Communications shall not use the Collocation Space for marketing purposes, nor shall it place any identifying signs or markings outside the Collocation Space or on the grounds of the Premises.

- 5.4 Clearwave Communications shall place a plaque or affix other identification (e.g., stenciling) to Clearwave Communications's equipment, in order for BellSouth to identify Clearwave Communications's equipment, including a list of emergency contacts with telephone numbers.
- 5.5 Entrance Facilities. Clearwave Communications may elect to place Clearwave Communications-owned or Clearwave Communications-leased fiber entrance facilities into its Collocation Space. BellSouth will designate the point of interconnection in close proximity to the Premises building housing the Collocation Space, such as at an entrance manhole or a cable vault, which are physically accessible by both Parties. Clearwave Communications will provide and place fiber cable at the point of entrance of sufficient length to be pulled through conduit and into the splice location. Clearwave Communications will provide and install a sufficient length of fire retardant riser cable, to which the entrance cable will be spliced by BellSouth. The fire retardant riser cable will extend from the splice location to Clearwave Communications's equipment in the Collocation Space. In the event Clearwave Communications utilizes a non-metallic, riser-type entrance facility, a splice will not be required. Clearwave Communications must contact BellSouth for instructions prior to placing any entrance facility cable in the manhole. Clearwave Communications is responsible for maintenance of the entrance facilities. At Clearwave Communications's option, BellSouth will accommodate, where technically feasible, a microwave entrance facility, pursuant to separately negotiated terms and conditions. In the case of adjacent collocation, copper facilities may be used between the adjacent collocation arrangement and the central office demarcation point unless BellSouth determines that limited space is available for the placement of entrance facilities.
- 5.5.1 Dual Entrance Facilities. BellSouth will provide at least two interconnection points at each Premise where at least two such interconnection points are available and capacity exists. Upon receipt of a request by Clearwave Communications for dual entrance facilities to its physical Collocation Space, BellSouth shall provide Clearwave Communications with information regarding BellSouth's capacity to accommodate the requested dual entrance facilities. If conduit in the serving manhole(s) is available and is not reserved for another purpose or for utilization within twelve (12) months of the receipt of an application for collocation, BellSouth will make the requested conduit space available for installing a second entrance facility to Clearwave Communications's arrangement. The location of the serving manhole(s) will be determined at the sole discretion of BellSouth. Where dual entrance facilities are not available due to lack of capacity, BellSouth will provide this information to Clearwave Communications in the Application Response.
- 5.5.2 Shared Use. Clearwave Communications may utilize spare capacity on an existing interconnector's entrance facility for the purpose of providing an entrance facility to Clearwave Communications's collocation arrangement within the same Premises. BellSouth shall allow the splice, as long as the fiber is non-working fiber. Clearwave Communications must arrange with BellSouth in accordance with BellSouth's Special Construction Procedures, RL93-11-030BT, and provide a LOA from the other

- telecommunications carrier for BellSouth to perform the splice of the Clearwave Communications provided riser cable to the spare capacity on the entrance facility. If Clearwave Communications desires to allow another telecommunications carrier to use its entrance facilities, that telecommunications carrier must arrange with BellSouth in accordance with BellSouth's Special Construction Procedures, RL93-11-030BT, and provide a LOA from Clearwave Communications for BellSouth to perform the splice of that telecommunications carrier's provided riser cable to the spare capacity on Clearwave Communications's entrance facility.
- 5.6 Demarcation Point. BellSouth will designate the point(s) of demarcation between Clearwave Communications's equipment and/or network and BellSouth's network. Each Party will be responsible for the maintenance and operation of all equipment/facilities on its side of the demarcation point. For 2-wire and 4-wire connections to BellSouth's network, the demarcation point shall be a common block on the BellSouth designated conventional distributing frame (CDF). Clearwave Communications shall be responsible for providing, and Clearwave Communications's BellSouth Certified Supplier shall be responsible for installing and properly labeling/stenciling the common block and any necessary cabling identified in Section 7 of this Attachment. For all other terminations, BellSouth shall designate a demarcation point on a per arrangement basis. Clearwave Communications or its agent must perform all required maintenance to the equipment/facilities on its side of the demarcation point, pursuant to Section 5.7, following, and may self-provision cross-connects that may be required within the Collocation Space to activate service requests.
- 5.6.1 In Tennessee, BellSouth will designate the point(s) of demarcation between Clearwave Communications's equipment and/or network and BellSouth's network. Each Party will be responsible for the maintenance and operation of all equipment/facilities on its side of the demarcation point. For connections to BellSouth's network, the demarcation point shall be a Clearwave Communications-provided Point of Termination Bay (POT Bay) in a common area within the Premises. Clearwave Communications shall be responsible for providing, and Clearwave Communications's BellSouth Certified Supplier shall be responsible for installing and properly labeling/stenciling the POT Bay, as well as installing the necessary cabling between Clearwave Communications's Collocation Space and the demarcation point. Clearwave Communications or its agent must perform all required maintenance to equipment/facilities on its side of the demarcation point, pursuant to Section 5.7, following, and may self-provision cross-connects that may be required within the Collocation Space to activate service requests. BellSouth will negotiate alternative rates, terms and conditions related to the demarcation point in Tennessee, in the event that Clearwave Communications desires to avoid the use of an intermediary device as contemplated by the Tennessee Regulatory Authority.
- 5.7 Clearwave Communications's Equipment and Facilities. Clearwave Communications, or if required by this Attachment, Clearwave Communications's BellSouth Certified Supplier, is solely responsible for the design, engineering, installation, testing,



provisioning, performance, monitoring, maintenance and repair of the equipment and facilities used by Clearwave Communications which must be performed in compliance with all applicable BellSouth Specifications. Such equipment and facilities may include, but are not limited to, cable(s), equipment, and point of termination connections. Clearwave Communications and its selected BellSouth Certified Supplier must follow and comply with all BellSouth requirements outlined in BellSouth's TR 73503, TR 73519, TR 73572, and TR 73564.

- 5.8 BellSouth's Access to Collocation Space. From time to time, BellSouth may require access to the Collocation Space. BellSouth retains the right to access Clearwave Communications's space for the purpose of making BellSouth equipment and building modifications (e.g., running, altering or removing racking, ducts, electrical wiring, HVAC, and cabling). BellSouth will give notice to Clearwave Communications at least forty-eight (48) hours before access to the Collocation Space is required. Clearwave Communications may elect to be present whenever BellSouth performs work in the Collocation Space. The Parties agree that Clearwave Communications will not bear any of the expense associated with this type of work.
- 5.9 Access. Pursuant to Section 12, Clearwave Communications shall have access to its Collocation Space twenty-four (24) hours a day, seven (7) days a week. Clearwave Communications agrees to provide the name and social security number, date of birth, or driver's license number of each employee, supplier, or agent of Clearwave Communications or Clearwave Communications's Guests that will be provided with access keys or cards (Access Keys) prior to the issuance of said Access Keys, using form RF-2906-C, the "CLEC and CLEC Certified Supplier Access Request and Acknowledgement" form. Key acknowledgement forms, the "Collocation Acknowledgement Sheet" for access cards and the "Key Acknowledgement Form" for keys must be signed by Clearwave Communications and returned to BellSouth Access Management within fifteen (15) calendar days of Clearwave Communications's receipt. Failure to return these properly acknowledged forms will result in the holding of subsequent access key or card requests until the proper acknowledgement documents have been received by BellSouth and reflect current information. Access Keys may not be duplicated under any circumstances. Clearwave Communications agrees to be responsible for all Access Keys and for the return of all Access Keys in the possession of Clearwave Communications's employees, suppliers, Guests, or agents after termination of the employment relationship, the contractual obligation with Clearwave Communications ends, upon the termination of this Attachment, or upon the termination of occupancy of an individual collocation arrangement.
- 5.9.1 BellSouth will permit one accompanied site visit to Clearwave Communications's designated collocation arrangement location, after receipt of the BFFO without charge to Clearwave Communications. Clearwave Communications must submit to BellSouth the completed Access Control Request Form for all employees or agents requiring access to the Premises within a minimum of thirty (30) calendar days prior to the date Clearwave Communications desires access to the Collocation Space. In order to permit reasonable access during construction of the Collocation Space, Clearwave

- Communications may submit a request for its one accompanied site visit to its designated collocation arrangement location at any time subsequent to BellSouth's receipt of the BFFO. In the event Clearwave Communications desires access to the Collocation Space after submitting such a request, but prior to the approval of its access request, in addition to the first accompanied free visit, BellSouth shall permit Clearwave Communications to access the Collocation Space accompanied by a security escort, at Clearwave Communications's expense. Clearwave Communications must request escorted access to its designated collocation arrangement location at least three (3) business days prior to the date such access is desired.
- 5.10 Lost or Stolen Access Keys. Clearwave Communications shall notify BellSouth in writing immediately in the case of lost or stolen Access Keys. If it becomes necessary for BellSouth to re-key buildings or deactivate a card as a result of a lost Access Key(s) or for failure to return an Access Key(s), Clearwave Communications shall pay for all reasonable costs associated with the re-keying or deactivating the card.
- 5.11 Interference or Impairment. Notwithstanding any other provisions of this Attachment, Clearwave Communications shall not use any product or service provided under this Agreement, any other service related thereto or used in combination therewith, or place or use any equipment or facilities in any manner that 1) significantly degrades, interferes with or impairs service provided by BellSouth or by any other entity or any person's use of its telecommunications services; 2) endangers or damages the equipment, facilities or any other property of BellSouth or of any other entity or person; 3) compromises the privacy of any communications; or 4) creates an unreasonable risk of injury or death to any individual or to the public. If BellSouth reasonably determines that any equipment or facilities of Clearwave Communications violates the provisions of this paragraph, BellSouth shall provide written notice to Clearwave Communications, which shall direct Clearwave Communications to cure the violation within forty-eight (48) hours of Clearwave Communications's actual receipt of written notice or, at a minimum, to commence curative measures within twenty-four (24) hours and to exercise reasonable diligence to complete such measures as soon as possible thereafter. After receipt of the notice, the Parties agree to consult immediately and, if necessary, to conduct an inspection of the arrangement.
- 5.11.1 Except in the case of the deployment of an advanced service which significantly degrades the performance of other advanced services or traditional voice band services, if Clearwave Communications fails to take curative action within forty-eight (48) hours or if the violation is of a character that poses an immediate and substantial threat of damage to property or injury or death to any person, or any other significant degradation, interference or impairment of BellSouth's or another entity's service, then and only in that event, BellSouth may take such action as it deems appropriate to correct the violation, including, without limitation, the interruption of electrical power to Clearwave Communications's equipment. BellSouth will endeavor, but is not required, to provide notice to Clearwave Communications prior to the taking of such action and BellSouth shall have no liability to Clearwave Communications for any

- damages arising from such action, except to the extent that such action by BellSouth constitutes willful misconduct.
- 5.11.2 For purposes of this Section, the term “significantly degrades” shall be defined as an action that noticeably impairs a service from a user’s perspective. In the case of the deployment of an advanced service which significantly degrades the performance of other advanced services or traditional voice band services and Clearwave Communications fails to take curative action within forty-eight (48) hours, then BellSouth will establish before the Commission that the technology deployment is causing the significant degradation. Any claims of network harm presented to Clearwave Communications or, if subsequently necessary, the Commission must be supported by BellSouth with specific and verifiable information. When BellSouth demonstrates that a certain technology deployed by Clearwave Communications is significantly degrading the performance of other advanced services or traditional voice band services, Clearwave Communications shall discontinue deployment of that technology and migrate its customers to technologies that will not significantly degrade the performance of other such services. Where the only degraded service itself is a known disturber, and the newly deployed technology satisfies at least one of the criteria for a presumption that it is acceptable for deployment under Section 47 C.F.R. 51.230, the degraded service shall not prevail against the newly-deployed technology
- 5.12 Personalty and its Removal. Facilities and equipment placed by Clearwave Communications in the Collocation Space shall not become a part of the Collocation Space, even if nailed, screwed or otherwise fastened to the Collocation Space, but shall retain their status as personal property and may be removed by Clearwave Communications at any time. Any damage caused to the Collocation Space by Clearwave Communications’s employees, suppliers, agents or representatives during the removal of such property shall be promptly repaired by Clearwave Communications at its sole expense. If Clearwave Communications decides to remove equipment from its Collocation Space and the removal requires no physical change, BellSouth will bill Clearwave Communications a Supplemental Application Fee (Administrative Only Application Fee) as set forth in Exhibit B. This non-recurring fee will be billed on the date that BellSouth provides an Application Response.
- 5.13 Alterations. Under no condition shall Clearwave Communications or any person acting on behalf of Clearwave Communications make any rearrangement, modification, augment, improvement, addition, and/or other alteration which could affect in any way space, power, HVAC, and/or safety considerations to the Collocation Space or the Premises, hereinafter referred to individually or collectively as “Augments”, without the express written consent of BellSouth, which shall not be unreasonably withheld. The cost of any such Augment shall be paid by Clearwave Communications. Any such Augment shall require an application and will result in the assessment of an application fee, which will be billed by BellSouth on the date that BellSouth provides Clearwave Communications with an Application Response.

5.14 Janitorial Service. Clearwave Communications shall be responsible for the general upkeep of its Collocation Space. Clearwave Communications shall arrange directly with a BellSouth Certified Supplier for janitorial services applicable to Caged Collocation Space. BellSouth shall provide a list of such suppliers on a site-specific basis, upon request.

**6. Ordering and Preparation of Collocation Space**

6.1 If any state or federal regulatory agency imposes procedures or intervals applicable to Clearwave Communications and BellSouth that are different from the procedures or intervals set forth in this Section, whether now in effect or that become effective after execution of this Agreement, those procedures or intervals shall supersede the requirements set forth herein for that jurisdiction for all applications that are submitted for the first time after the effective date thereof.

6.2 Initial Application. For Clearwave Communications or Clearwave Communications's Guest(s) initial equipment placement, Clearwave Communications shall submit to BellSouth a Physical Expanded Interconnection Application Document (Initial Application). The Initial Application is considered Bona Fide when it is complete and accurate, meaning that all of the required fields on the application are completed with the appropriate type of information. An application fee will apply to each application submitted by Clearwave Communications, which will be billed by BellSouth on the date that BellSouth provides Clearwave Communications with an Application Response.

6.3 Subsequent Application. In the event Clearwave Communications or Clearwave Communications's Guest(s) desires to modify the use of the Collocation Space after a BFFO, Clearwave Communications shall complete an application that contains all of the detailed information associated with an Augment **to** the Collocation Space, as defined in Section 5.13 of this Attachment (Subsequent Application). The Subsequent Application is considered Bona Fide when it is complete and accurate, meaning that all of the required fields on the Subsequent Application are completed with the appropriate type of information associated with the Augment. BellSouth shall determine what modifications, if any, to the Premises are required to accommodate the change requested by Clearwave Communications in the application. Such modifications to the Premises may include, but are not limited to: floor loading changes, changes necessary to meet HVAC requirements, changes to power plant requirements, equipment additions, etc.

6.3.1 Subsequent Application Fee. The application fee paid by Clearwave Communications for its request for an Augment shall be dependent upon the level of assessment needed for the Augment requested. Where the Subsequent Application does not require assessment for provisioning or construction work but requires administrative costs by BellSouth, a Subsequent Application Fee (Administrative Only Application Fee) will be required as set forth in Exhibit B. This Administrative Only Application Fee will be

applicable in instances such as Transfer of Ownership of the Collocation Space, Removal of Equipment from the Collocation Space, modification to an application prior to BFFO and V-to-P Conversion (In Place). The fee for a Subsequent Application where the Augment requested has limited effect (e.g., requires limited assessment but no capital expenditure by BellSouth as sufficient cable support structure, HVAC, power and terminations are available) shall be the Subsequent Application Fee as set forth in Exhibit B. If the modification requires capital expenditure, an Initial Application Fee shall apply. This nonrecurring fee will be billed on the date that BellSouth provides Clearwave Communications with an Application Response.

- 6.4 Space Preferences. If Clearwave Communications has previously requested and received a Space Availability Report for the Premises, Clearwave Communications may submit up to three (3) space preferences on its application by identifying the specific space identification numbers referenced on the Space Availability Report for the space it is requesting. In the event BellSouth cannot accommodate the Clearwave Communications's preference(s), Clearwave Communications may accept the space allocated by BellSouth or cancel its application and submit another application requesting additional space preferences for the same central office. This application will be treated as a new application and an application fee will apply. The application fee will be billed by BellSouth on the date that BellSouth provides Clearwave Communications with an Application Response.
- 6.5 Space Availability Notification.
- 6.5.1 Unless otherwise specified, BellSouth will respond to an application within ten (10) calendar days as to whether space is available or not available within a requested Premises. BellSouth will also respond as to whether the application is Bona Fide and if it is not Bona Fide, the items necessary to cause the application to become Bona Fide. If the amount of space requested is not available, BellSouth will notify Clearwave Communications of the amount of space that is available and no application fee will apply. When BellSouth's response includes an amount of space less than that requested by Clearwave Communications or space that is configured differently, no application fee will apply. If Clearwave Communications decides to accept the available space, Clearwave Communications must resubmit its application to reflect the actual space available, including the configuration of the space, prior to submitting a BFFO. When Clearwave Communications resubmits its application, BellSouth will bill Clearwave Communications the appropriate application fee.
- 6.5.2 BellSouth will respond to a Florida application within fifteen (15) calendar days as to whether space is available or not available within a Premises. BellSouth will also respond as to whether the application is Bona Fide and if it is not Bona Fide, the items necessary to cause the application to become Bona Fide. If a lesser amount of space than requested is available, BellSouth will provide an Application Response for the amount of space that is available and bill Clearwave Communications an appropriate application fee on the date that BellSouth provides the Application Response. When

- BellSouth's Application Response includes an amount of space less than that requested by Clearwave Communications or space that is configured differently, if Clearwave Communications decides to accept the available space, Clearwave Communications must amend its application to reflect the actual space available, including the configuration of the space, prior to submitting a BFFO.
- 6.5.3 BellSouth will respond to a Louisiana application within ten (10) calendar days in regard to space availability for one (1) to ten (10) applications; fifteen (15) calendar days for eleven (11) to twenty (20) applications; and for more than twenty (20) applications, the response interval is increased by five (5) calendar days for every five additional applications received within five (5) business days. BellSouth will also respond as to whether the application is Bona Fide and if it is not Bona Fide, the items necessary to cause the application to become Bona Fide. If the amount of space requested is not available, BellSouth will notify Clearwave Communications of the amount of space that is available and no application fee will apply. When BellSouth's response includes an amount of space less than that requested by Clearwave Communications or space that is configured differently, no application fee will apply. If Clearwave Communications decides to accept the available space, Clearwave Communications must resubmit its application to reflect the actual space available, including the configuration of the space, prior to submitting a BFFO. When Clearwave Communications resubmits its application, BellSouth will bill Clearwave Communications the appropriate application fee. Denial of Application. If BellSouth notifies Clearwave Communications that no space is available (Denial of Application), BellSouth will not assess an application fee to Clearwave Communications. After notifying Clearwave Communications that BellSouth has no available space in the requested Premises, BellSouth will allow Clearwave Communications, upon request, to tour the entire Premises within ten (10) calendar days of such Denial of Application. In order to schedule this tour within ten (10) calendar days, the request for the tour of the Premises must be received by BellSouth within five (5) calendar days of the Denial of Application.
- 6.6 Filing of Petition for Waiver. Upon Denial of Application, BellSouth will timely file a petition with the Commission pursuant to 47 U.S.C. § 251(c)(6). BellSouth shall provide to the Commission any information requested by that Commission. Such information shall include which space, if any, BellSouth or any of BellSouth's affiliates have reserved for future use and a detailed description of the specific future uses for which the space has been reserved. Subject to an appropriate nondisclosure agreement or provision, BellSouth shall permit Clearwave Communications to inspect any floor plans or diagrams that BellSouth provides to the Commission.
- 6.7 Waiting List. On a first-come, first-served basis, governed by the date of receipt of an application or Letter of Intent, BellSouth will maintain a waiting list of requesting carriers who have either received a Denial of Application or, where it is publicly known that the Premises is out of space, have submitted a Letter of Intent to collocate in that Premises. BellSouth will notify the telecommunications carriers on the waiting

- list that can be accommodated by the amount of space that becomes available, according to the position of the telecommunications carriers on said waiting list.
- 6.7.1 In Florida, on a first-come, first-served basis, governed by the date of receipt of an application or Letter of Intent, BellSouth will maintain a waiting list of requesting carriers who have either received a Denial of Application or, where it is publicly known that the Premises is out of space, have submitted a Letter of Intent to collocate in that Premises. Sixty (60) calendar days prior to space becoming available, if known, BellSouth will notify the Commission and the telecommunications carriers on the waiting list by mail when space becomes available according to the position of each telecommunications carrier on said waiting list. If BellSouth does not know sixty (60) calendar days in advance of when space will become available, BellSouth will notify the Commission and the telecommunications carriers on the waiting list within two (2) business days of the determination that space is available. A telecommunications carrier that, upon denial of physical collocation, requests virtual collocation shall be automatically placed on the waiting list.
- 6.7.2 When space becomes available, Clearwave Communications must submit an updated, complete, and correct application to BellSouth within thirty (30) calendar days of notification by BellSouth that space will be available in the Premises previously out of space. If Clearwave Communications has originally requested caged Collocation Space and cageless Collocation Space becomes available, Clearwave Communications may refuse such space and notify BellSouth in writing within the thirty (30) day timeframe that Clearwave Communications wants to maintain its place on the waiting list, without accepting the available cageless Collocation Space. Clearwave Communications may accept an amount of space less than its originally requested space by submitting an application as set forth above, and upon request, may maintain its position on the waiting list for the remaining space that was initially requested. If Clearwave Communications does not submit an application or notify BellSouth in writing as described above, BellSouth will offer the space to the next telecommunications carrier on the waiting list and remove Clearwave Communications from the waiting list. Upon request, BellSouth will advise Clearwave Communications as to its position on the waiting list.
- 6.8 Public Notification. BellSouth will maintain on its Interconnection Services website a notification document that will indicate all Premises that are without available space. BellSouth shall update such document within ten (10) calendar days of the date that BellSouth becomes aware that insufficient space is available to accommodate physical collocation. BellSouth will also post a document on its Interconnection Services website that contains a general notice when space has become available in a Premises previously on the space exhaust list.
- 6.9 Application Response.
- 6.9.1 In Alabama, Georgia, Kentucky, Mississippi, North Carolina, South Carolina, and Tennessee, when space has been determined to be available for caged or cageless

- arrangements, BellSouth will provide an Application Response within twenty (20) calendar days of receipt of a Bona Fide application. The Application Response will include, at a minimum, the configuration of the space, the Cable Installation Fee, Cable Records Fee, and any other applicable space preparation fees, as described in Section 8.
- 6.9.2 In Florida, within fifteen (15) calendar days of receipt of a Bona Fide application, when space has been determined to be available or when a lesser amount of space than that requested is available, then with respect to the space available, BellSouth will provide an Application Response including sufficient information to enable Clearwave Communications to place a Firm Order. The Application Response will include, at a minimum, the configuration of the space, the Cable Installation Fee, Cable Records Fee, and the space preparation fees, as described in Section 8. When Clearwave Communications submits ten (10) or more applications within ten (10) calendar days, the initial fifteen (15) calendar day response interval will increase by ten (10) calendar days for every additional ten (10) applications or fraction thereof.
- 6.9.3 In Louisiana, when space has been determined to be available, BellSouth will provide an Application Response within thirty (30) calendar days for one (1) to ten (10) applications; thirty-five (35) calendar days for eleven (11) to twenty (20) applications; and for requests of more than twenty (20) applications, the Application Response interval will be increased by five (5) calendar days for every five (5) applications received within five (5) business days. The Application Response will include, at a minimum, the configuration of the space, the Cable Installation Fee, Cable Records Fee, and the space preparation fees, as described in Section 8.
- 6.10 Application Modifications.
- 6.10.1 If a modification or revision is made to any information in the Bona Fide Application prior to a BFFO, with the exception of modifications to Customer Information, Contact Information or Billing Contact Information, at the request of Clearwave Communications, or necessitated by technical considerations, the application shall be considered a new application and handled as a new application with respect to the response and provisioning intervals. BellSouth will charge Clearwave Communications the appropriate application fee associated with the level of assessment performed by BellSouth. If the modification requires no labor or capital expenditure by BellSouth, but BellSouth must perform an assessment of the application to evaluate whether or not BellSouth would be required to perform necessary infrastructure or provisioning activities, then an Administrative Only Application Fee shall apply. The fee for an application modification where the modification requested has limited effect (e.g., requires labor expenditure but no capital expenditure by BellSouth and where sufficient cable support structure, HVAC, power and terminations are available) shall be the Subsequent Application Fee as set forth in Exhibit B. A modification involving a capital expenditure by BellSouth shall require Clearwave Communications to submit the application with an Initial



Application Fee. This nonrecurring fee will be billed by BellSouth on the date that BellSouth provides Clearwave Communications with an Application Response.

6.11 Bona Fide Firm Order.

6.11.1 Clearwave Communications shall indicate its intent to proceed with equipment installation in a BellSouth Premises by submitting a Bona Fide Firm Order (BFFO) to BellSouth. The BFFO must be received by BellSouth no later than thirty (30) calendar days after BellSouth's Application Response to Clearwave Communications's Bona Fide Application or Clearwave Communications's application will expire.

6.11.2 BellSouth will establish a firm order date based upon the date BellSouth is in receipt of Clearwave Communications's BFFO. BellSouth will acknowledge the receipt of Clearwave Communications's BFFO within seven (7) calendar days of receipt, so that Clearwave Communications will have positive confirmation that its BFFO has been received. BellSouth's response to a BFFO will include a Firm Order Confirmation, which contains the firm order date. No revisions can be made to a BFFO.

**7. Construction and Provisioning**

7.1 Construction and Provisioning Intervals.

7.1.1 In Florida, BellSouth will complete construction for collocation arrangements as soon as possible within a maximum of ninety (90) calendar days from receipt of a BFFO or as agreed to by the Parties. For Augments requested to the Collocation Space after initial space completion, BellSouth will complete construction for collocation arrangements as soon as possible within a maximum of forty-five (45) calendar days from receipt of a BFFO or as agreed to by the Parties. If BellSouth does not believe that construction will be completed within the relevant timeframe and BellSouth and Clearwave Communications cannot agree upon a completion date, within forty-five (45) calendar days of receipt of the BFFO for an initial request, and within thirty (30) calendar days of receipt of the BFFO for an Augment, BellSouth may seek an extension from the Commission.

7.1.2 In Alabama, Georgia, Kentucky, Louisiana, Mississippi, North Carolina, South Carolina, and Tennessee, BellSouth will complete construction for caged collocation arrangements under ordinary conditions as soon as possible within a maximum of ninety (90) calendar days from receipt of a BFFO or as agreed to by the Parties. BellSouth will complete construction for cageless collocation arrangements under ordinary conditions as soon as possible within a maximum of sixty (60) calendar days from receipt of a BFFO and ninety (90) calendar days from receipt of a BFFO for extraordinary conditions, or as agreed to by the Parties. Ordinary conditions are defined as space available with only minor changes to support systems required such as, but not limited to, HVAC, cabling and the power plant. Extraordinary conditions shall include, but not be limited to, major BellSouth equipment rearrangements or additions; power plant additions or upgrades; major mechanical additions or upgrades;

a major upgrade for ADA compliance; environmental hazard or hazardous materials abatement; and arrangements for which equipment shipping intervals are extraordinary in length. The Parties may mutually agree to renegotiate an alternative provisioning interval or BellSouth may seek a waiver from this interval from the Commission.

- 7.1.3 When Clearwave Communications adds equipment within initial demand parameters that requires no additional space preparation work on the part of BellSouth, then no additional charges or additional intervals will be imposed by BellSouth that would delay Clearwave Communications's operation.
- 7.1.4 In the states of Alabama, Georgia, Kentucky, Louisiana, Mississippi, North Carolina, and South Carolina, BellSouth will provide the reduced intervals outlined below to Clearwave Communications, when Clearwave Communications requests an Augment after the Space Ready Date for existing physical collocation space. In such instances, Clearwave Communications must provide an accurate front equipment view (a.k.a. rack elevation drawing) specifying bay(s) for Clearwave Communications's point of termination.
- 7.1.4.1 Simple Augments will be completed within twenty (20) calendar days after receipt of the BFFO for an:
- Extension of Existing AC Circuit Capacity within Arrangement Where Sufficient Circuit Capacity is Available
  - Fuse Change and/or Increase or Decrease -48V DC Power from Existing ILEC BDFB
- 7.1.4.2 Minor Augments will be completed within forty-five (45) calendar days after receipt of the BFFO for:
- 168 DS1s Terminations at the ILEC Demarcation Frame (Databasing Only; Panels, Relay Racks and Overhead Racking Exist)
  - 96 DS3s Terminations at the ILEC Demarcation Frame (Databasing Only; Panels, Relay Racks and Overhead Racking Exist)
  - 99 Fiber Terminations at the ILEC Demarcation Frame (Databasing Only; Panels, Relay Racks and Overhead Racking Exist)
  - Maximum of 2000 Service Ready DS0 Terminations at the ILEC Demarcation Frame (Databasing Only; Panels, Relay Racks and Overhead Racking Exist)
- 7.1.4.3 Intermediate Augments will be completed within sixty (60) calendar days after receipt of the BFFO for:
- 168 DS1s (Databasing and Installation of Termination Panels, Relay Racks or Additional Structure as Required)
  - 96 DS3s (Databasing and Installation of Termination Panels, Relay Racks or Additional Structure as Required)
  - 99 Fiber Terminations (Databasing and Installation of Termination Panels, Relay Racks or Additional Structure as Required)

- 2000 DS0s (Databasing and Installation of Termination Panels, Relay Racks or Additional Structure as Required)
- Install Cable Racking or Other Support Structures as Required to Support Co-Carrier Cross Connects (Adequate Floor or Ceiling Structural Capacity Exists and Support/Protection Structure for Fiber Patch Cord is Excluded)

- 7.1.4.4 Major Augments – Physical Collocation will be completed within ninety (90) calendar days after BFFO and includes all requests for additional physical collocation space (caged or cageless).
- 7.1.4.5 Major Augments – Virtual Collocation will be completed within seventy-five (75) calendar days after BFFO and includes all requests for additional virtual collocation space.
- 7.1.4.6 If Clearwave Communications submits an augment application request that includes two augment items from the same category in Sections 7.1.4.1, 7.1.4.2, and 7.1.4.3 above, the augment interval associated with the next highest augment category will apply (e.g., if two items from the minor augment category are requested on the same request, then an interval of sixty (60) calendar days from the receipt of the BFFO would apply, which is the interval associated with the intermediate category).
- 7.1.4.7 If Clearwave Communications submits an augment application request that includes three augment items from the same category in Sections 7.1.4.1, 7.1.4.2, and 7.1.4.3 above, the major augment interval of ninety (90) calendar days from the receipt of the BFFO would apply (e.g., if three items from the simple augment category are requested on the same request for a physical collocation arrangement, then an interval of ninety (90) calendar days from the receipt of the BFFO would apply, which is the major physical augment interval; likewise if three items from the simple augment category are requested on the same request for a virtual collocation arrangement, then an interval of seventy-five (75) calendar days from the receipt of the BFFO would apply, which is the major virtual augment interval; ).
- 7.1.4.8 If Clearwave Communications submits an augment application request that includes one augment item from two separate categories in Sections 7.1.4.1, 7.1.4.2 and 7.1.4.3 above, the augment interval associated with the highest augment category will apply (e.g., if an item from the minor augment category and an item from the intermediate augment category are requested on the same request, then an interval of sixty (60) calendar days from the receipt of the BFFO would apply, which is the interval associated with the intermediate augment category).
- 7.1.4.9 All Augments not expressly included in the Simple, Minor, Intermediate or Major categories as outlined above will be placed into the appropriate category as negotiated by Clearwave Communications and BellSouth. If Clearwave Communications and BellSouth are unable to determine the appropriate category through negotiation, then the appropriate major augment category identified in Sections 7.1.4.4 and 7.1.4.5 would apply based on whether the augment request is for Clearwave Communications's physical or virtual collocation arrangement.

- 7.1.4.10 Individual application fees associated with simple, minor and intermediate augment applications are contained in Exhibit B. The appropriate application fee will be assessed to Clearwave Communications at the time BellSouth provides Clearwave Communications with the Application Response. Clearwave Communications will be assessed a Subsequent Application Fee for all Major Augment applications (Major Augments are defined above in Sections 7.1.4.4 and 7.1.4.5). The Subsequent Application Fee is also reflected in Exhibit B of this Attachment.
- 7.2 Joint Planning. Joint planning between BellSouth and Clearwave Communications will commence within a maximum of twenty (20) calendar days from BellSouth's receipt of a BFFO. BellSouth will provide the preliminary design of the Collocation Space and the equipment configuration requirements as reflected in the Bona Fide application and affirmed in the BFFO. The Collocation Space completion interval will be provided to Clearwave Communications during the joint planning meeting.
- 7.3 Permits. Each Party or its agent(s) will diligently pursue filing for the permits required for the scope of work to be performed by that Party or its agent(s) within ten (10) calendar days of the completion of the finalized construction design and specifications.
- 7.4 Acceptance Walkthrough. Clearwave Communications will schedule and complete an acceptance walkthrough of each Collocation Space with BellSouth within fifteen (15) calendar days of BellSouth's notification to Clearwave Communications that the Collocation Space is ready for occupancy. In the event Clearwave Communications fails to complete an acceptance walkthrough within this fifteen (15) day interval, the Collocation Space shall be deemed accepted by Clearwave Communications on the Space Ready Date. BellSouth will correct any deviations to Clearwave Communications's original or jointly amended design and/or specification requirements within seven (7) calendar days after the walkthrough, unless the Parties jointly agree upon a different timeframe.
- 7.5 Circuit Facility Assignments (CFAs). Unless otherwise specified, BellSouth will provide CFAs to Clearwave Communications prior to the applicable provisioning interval set forth herein (Provisioning Interval) for those Premises in which Clearwave Communications has a physical collocation arrangement with no POT bay or with a POT bay provided by BellSouth. BellSouth cannot provide CFAs to Clearwave Communications prior to the Provisioning Interval for those Premises in which Clearwave Communications has a physical collocation arrangement with a POT bay provided by Clearwave Communications or a virtual collocation arrangement, until Clearwave Communications provides BellSouth with the following information:
- 7.5.1 For a physical collocation arrangement with a Clearwave Communications-provided POT bay - a complete layout of the POT panels (equipment inventory update (EIU) form) showing locations, speeds, etc.
- 7.5.2 For a virtual collocation arrangement - a complete layout of Clearwave Communications's equipment (equipment inventory update (EIU) form), including the locations of the low speed ports and the specific frame terminations to which the

- equipment will be wired by Clearwave Communications's BellSouth Certified Supplier.
- 7.5.3 BellSouth cannot begin work on the CFAs until the complete and accurate EIU form is received from Clearwave Communications. If the EIU form is provided ten (10) calendar days prior to the ending date of the Provisioning Interval, then CFAs will be made available by the ending date of the Provisioning Interval. If the EIU form is not received ten (10) calendar days prior to the ending date of the Provisioning Interval, then the CFAs will be provided within ten (10) calendar days of receipt of the EIU form.
- 7.5.4 BellSouth will bill Clearwave Communications a nonrecurring charge, as set forth in Exhibit B, each time Clearwave Communications requests a resend of its CFAs for any reason other than a BellSouth error in the CFAs initially provided to Clearwave Communications.
- 7.6 Use of BellSouth Certified Supplier. Clearwave Communications shall select a supplier which has been approved as a BellSouth Certified Supplier to perform all engineering and installation work. Clearwave Communications and Clearwave Communications's BellSouth Certified Supplier must follow and comply with all of BellSouth's requirements, outlined in BellSouth TR 73503, TR 73519, TR 73572, and TR 73564. In some cases, Clearwave Communications must select separate BellSouth Certified Suppliers for those work activities associated with transmission equipment, switching equipment and power equipment. BellSouth shall provide Clearwave Communications with a list of BellSouth Certified Suppliers, upon request. The BellSouth Certified Supplier(s) shall be responsible for installing Clearwave Communications's equipment and associated components, extending power cabling to the BellSouth power distribution frame, performing operational tests after installation is complete, and notifying BellSouth's equipment engineers and Clearwave Communications upon successful completion of installation, etc. The BellSouth Certified Supplier shall bill Clearwave Communications directly for all work performed for Clearwave Communications pursuant to this Attachment. BellSouth shall have no liability for, nor responsibility to pay, such charges imposed by Clearwave Communications's BellSouth Certified Supplier. BellSouth shall make available its supplier certification program to Clearwave Communications or any supplier proposed by Clearwave Communications and will not unreasonably withhold certification. All work performed by or for Clearwave Communications shall conform to generally accepted industry standards.
- 7.7 Alarm and Monitoring. BellSouth shall place environmental alarms in the Premises for the protection of BellSouth equipment and facilities. Clearwave Communications shall be responsible for placement, monitoring and removal of environmental and equipment alarms used to service Clearwave Communications's Collocation Space. Upon request, BellSouth will provide Clearwave Communications with an applicable tariffed service(s) to facilitate remote monitoring of collocated equipment by Clearwave

Communications. Both Parties shall use best efforts to notify the other of any verified environmental condition known to that Party.

- 7.8 Virtual to Physical Collocation Relocation. In the event physical Collocation Space was previously denied at a location due to technical reasons or space limitations and physical Collocation Space has subsequently become available, Clearwave Communications may relocate its existing virtual collocation arrangement(s) to a physical collocation arrangement(s) and pay the appropriate fees associated with physical collocation and the rearrangement or reconfiguration of services terminated in the virtual collocation arrangement, as outlined in the appropriate BellSouth Tariffs. In the event BellSouth knows when additional space for physical collocation may become available at the location requested by Clearwave Communications, such information will be provided to Clearwave Communications in BellSouth's written denial of physical collocation space. To the extent that (i) physical Collocation Space becomes available to Clearwave Communications within one hundred eighty (180) calendar days of BellSouth's written denial of Clearwave Communications's request for physical collocation, (ii) BellSouth had knowledge that the space was going to become available, and (iii) Clearwave Communications was not informed in the written denial that physical Collocation Space would become available within such one hundred eighty (180) calendar days, then Clearwave Communications may relocate its virtual collocation arrangement to a physical collocation arrangement and will receive a credit for any nonrecurring charges previously paid for such virtual collocation. Clearwave Communications must arrange with a BellSouth Certified Supplier for the relocation of equipment from its virtual Collocation Space to its physical Collocation Space and will bear the cost of such relocation.
- 7.8.1 In Alabama, BellSouth will complete a relocation from virtual collocation to cageless physical collocation within thirty (30) calendar days and from virtual collocation to caged physical collocation within ninety (90) calendar days.
- 7.9 Virtual to Physical Conversion (In-Place). Virtual collocation arrangements may be converted to "in-place" physical arrangements if the potential conversion meets the following four criteria: 1) there is no change in the amount of equipment or the configuration of the equipment that was in the virtual collocation arrangement; 2) the conversion of the virtual collocation arrangement will not cause the equipment or the results of that conversion to be located in a space that BellSouth has reserved for its own future needs; 3) the converted arrangement does not limit BellSouth's ability to secure its own equipment and facilities due to the location of the virtual collocation arrangement; and 4) any changes to the arrangement can be accommodated by existing power, HVAC, and other requirements. Unless otherwise specified, BellSouth will complete virtual to in-place physical collocation conversions within sixty (60) calendar days from receipt of the BFFO. BellSouth will bill Clearwave Communications an Administrative Only Application Fee as set forth in Exhibit B on the date that BellSouth provides an Application Response to Clearwave Communications.

- 7.9.1 In Alabama and Tennessee, BellSouth will complete Virtual to Physical Conversions (In Place) within thirty (30) calendar days from receipt of the BFFO.
- 7.10 Cancellation. If at any time prior to space acceptance, Clearwave Communications cancels its order for the Collocation Space(s) (Cancellation), BellSouth will bill the applicable nonrecurring rate(s) for any and all work processes for which work has begun or been completed. In Georgia, if Clearwave Communications cancels its order for Collocation Space at any time prior to space acceptance, BellSouth will bill Clearwave Communications for all costs incurred prior to the date of Cancellation and for any costs incurred as a direct result of the Cancellation, not to exceed the total amount that would have been due had the order not been cancelled.
- 7.11 Licenses. Clearwave Communications, at its own expense, will be solely responsible for obtaining from governmental authorities, and any other appropriate agency, entity, or person, all rights, privileges, and licenses necessary or required to operate as a provider of telecommunications services to the public or to build-out, equip and/or occupy the Collocation Space.
- 7.12 Environmental Compliance. The Parties agree to utilize and adhere to the Environmental Hazard Guidelines identified in Exhibit A attached hereto.
- 8. Rates and Charges**
- 8.1 Application Fee. BellSouth shall assess an application fee via a service order, which shall be issued at the time BellSouth responds that space is available pursuant to Section 6.10 (Application Response). BellSouth will bill this nonrecurring fee on the date that BellSouth provides an Application Response to Clearwave Communications.
- 8.1.1 In Tennessee the applicable application fee is the planning fee for both Initial Applications and Subsequent Applications placed by Clearwave Communications. BellSouth will bill this nonrecurring fee on the date that BellSouth provides an Application Response to Clearwave Communications.
- 8.2 Cable Installation. Cable Installation Fee(s) are assessed per entrance cable placed. This nonrecurring fee will be billed by BellSouth upon receipt of Clearwave Communications's BFFO.
- 8.3 Recurring Charges. If Clearwave Communications has met the applicable fifteen (15) calendar day walkthrough interval(s) specified in Section 4, billing for recurring charges will begin upon the Space Acceptance Date. In the event that Clearwave Communications fails to complete an acceptance walkthrough within the applicable fifteen (15) calendar day interval(s), billing for recurring charges will commence on the Space Ready Date. If Clearwave Communications occupies the space prior to the Space Ready Date, the date Clearwave Communications occupies the space becomes the new Space Acceptance Date and billing for recurring charges begin on that date.

- 8.4 Space Preparation. Space preparation fees consist of a nonrecurring charge for firm order processing and monthly recurring charges for central office modifications assessed per arrangement, per square foot and common systems modifications assessed per arrangement, per square foot for cageless collocation and per cage for caged collocation. Clearwave Communications shall remit payment of the nonrecurring firm order processing fee coincident with submission of a BFFO. The charges recover the costs associated with preparing the Collocation Space, which includes survey, engineering of the Collocation Space, design and modification costs for network, building and support systems. In the event Clearwave Communications opts for cageless space, the space preparation fees will be assessed based on the total floor space dedicated to Clearwave Communications as prescribed in this Section.
- 8.5 Floor Space. The Floor Space Charge includes reasonable charges for lighting, HVAC, and other allocated expenses associated with maintenance of the Premises but does not include any power-related costs incurred by BellSouth. When the Collocation Space is enclosed, Clearwave Communications shall pay floor space charges based upon the number of square feet so enclosed. When the Collocation Space is not enclosed, Clearwave Communications shall pay floor space charges based upon the following floor space calculation: [(depth of the equipment lineup in which the rack is placed) + (0.5 x maintenance aisle depth) + (0.5 x wiring aisle depth)] X (width of rack and spacers). For purposes of this calculation, the depth of the equipment lineup shall consider the footprint of equipment racks plus any equipment overhang. BellSouth will assign unenclosed Collocation Space in conventional equipment rack lineups where feasible. In the event Clearwave Communications's collocated equipment requires special cable racking, isolated grounding or other treatment which prevents placement within conventional equipment rack lineups, Clearwave Communications shall be required to request an amount of floor space sufficient to accommodate the total equipment arrangement.
- 8.6 Power. BellSouth shall make available -48 Volt (-48V) Direct Current (DC) power for Clearwave Communications's Collocation Space at a BellSouth Power Board or BellSouth Battery Distribution Fuse Bay (BDFB) at Clearwave Communications's option within the Premises. BellSouth will revise recurring power charges to reflect a power upgrade upon notification of the completion of the upgrade by Clearwave Communications's BellSouth Certified Vendor. BellSouth will revise recurring power charges to reflect a power reduction upon BellSouth's receipt of the Power Reduction Form from Clearwave Communications certifying the completion of the power reduction, including the removal of the power cabling by Clearwave Communications's BellSouth Certified Supplier.
- 8.6.1 When obtaining power from a BDFB, fuses and power cables (A&B) must be engineered (sized), and installed by Clearwave Communications's BellSouth Certified Supplier. When obtaining power from a BellSouth power board, power cables (A&B) must be engineered (sized), and installed by Clearwave Communications's BellSouth Certified Supplier. Clearwave Communications is responsible for contracting with a BellSouth Certified Supplier for power distribution feeder cable runs from a BellSouth



- BDFB or BellSouth power board to Clearwave Communications's equipment. The determination of the BellSouth BDFB or BellSouth power board as the power source will be made at BellSouth's sole, but reasonable, discretion. The BellSouth Certified Supplier contracted by Clearwave Communications must provide BellSouth with a copy of the engineering power specifications prior to the day on which Clearwave Communications's equipment becomes operational (Commencement Date). BellSouth will provide the common power feeder cable support structure between the BellSouth BDFB or BellSouth power board and Clearwave Communications's arrangement area. Clearwave Communications shall contract with a BellSouth Certified Supplier who will be responsible for the following: dedicated power cable support structure within Clearwave Communications's arrangement, power cable feeds, and terminations of cable. Any terminations at a BellSouth power board must be performed by a BellSouth Certified Supplier. Clearwave Communications shall comply with all applicable National Electric Code (NEC), BellSouth TR73503, Telcordia and ANSI Standards regarding power cabling, installation, and maintenance.
- 8.6.2 If Clearwave Communications elects to install its own DC Power Plant, BellSouth shall provide Alternating Current (AC) power to feed Clearwave Communications's DC Power Plant. Charges for AC power will be assessed per breaker ampere per month. Rates include the provision of commercial and standby AC power. When obtaining power from a BellSouth service panel, protection devices and power cables must be engineered (sized), and installed by Clearwave Communications's BellSouth Certified Supplier except that BellSouth shall engineer and install protection devices and power cables for Adjacent Collocation. Clearwave Communications's BellSouth Certified Supplier must also provide a copy of the engineering power specifications prior to the Commencement Date. Charges for AC power shall be assessed pursuant to the rates specified in Exhibit B. AC power voltage and phase ratings shall be determined on a per location basis. At Clearwave Communications's option, Clearwave Communications may arrange for AC power in an Adjacent Collocation arrangement from a retail provider of electrical power.
- 8.6.3 In Tennessee, recurring charges for -48V DC power consumption will be assessed per ampere per month based upon the engineered and installed power feed fused ampere capacity. Rates include redundant feeder fuse positions (A&B) and common cable racks to Clearwave Communications's equipment or space enclosure. Clearwave Communications shall contract with a BellSouth Certified Supplier who will be responsible for the following: dedicated power cable support structure within Clearwave Communications's arrangement and terminations of cable within the Collocation Space.
- 8.6.3.1 In Tennessee, nonrecurring charges for -48V DC power distribution will be based on the common power feeder cable support structure between the BellSouth BDFB and Clearwave Communications's arrangement area.
- 8.6.4 In Alabama and Louisiana, Clearwave Communications has the option to purchase power directly from an electric utility company. Under such an option, Clearwave

Communications is responsible for contracting with the electric utility company for its own power feed and meter, and is financially responsible for purchasing all equipment necessary to accomplish the arrangement, including inverters, batteries, power boards, bus bars, BDFBs, backup power supplies and cabling. The actual work to install this arrangement must be performed by a BellSouth Certified Supplier hired by Clearwave Communications. Clearwave Communications's BellSouth Certified Supplier must comply with all applicable safety codes, including the National Electric Safety Codes, in installing this power arrangement. If Clearwave Communications previously had power supplied by BellSouth, Clearwave Communications may request to change its arrangement to obtain power from an electric utility company by submitting a Subsequent Application. BellSouth will waive any application fee for this subsequent application if no other change was requested therein. Any floor space, cable racking, etc. utilized by Clearwave Communications in provisioning said power will be billed on an ICB basis.

- 8.6.5 In South Carolina, Clearwave Communications has the option to purchase power directly from an electric utility company where technically feasible and where space is available in a requested Premises. Under such an option, Clearwave Communications is responsible for contracting with the electric utility company for its own power feed and meter, and is financially responsible for purchasing all equipment necessary to accomplish the arrangement, including inverters, batteries, power boards, bus bars, BDFBs, backup power supplies and power cabling. The actual work to install this arrangement must be performed by a BellSouth Certified Supplier hired by Clearwave Communications. Clearwave Communications's BellSouth Certified Supplier must comply with all applicable national, regional, state and local safety, electrical, fire and building codes, including the National Electric Safety Code standards, in installing this power arrangement, just as BellSouth is required to comply with these codes. Clearwave Communications must submit an application to BellSouth for the appropriate amount of Collocation Space that Clearwave Communications requires to install this type of power arrangement. BellSouth will evaluate the request and determine if the appropriate amount of space is available within the office for the installation of Clearwave Communications's power equipment and facilities. This type of power arrangement must be located in an appropriate area in the central office that has been properly conditioned for the installation of power equipment and conforms to the applicable national, regional, state and local safety, electrical, fire and building codes. BellSouth shall waive the application fee or any other nonrecurring charge that would otherwise be due from a CLEC that decides to reconfigure an existing collocation power arrangement so as to purchase power directly from an electric utility company as provided herein. Clearwave Communications shall be responsible for the recurring charges associated with the central office space needed for collocation of this type of power arrangement, including space required to place associated power-related equipment and facilities (i.e., batteries, generator, power meter, etc.). If there is no space available for this type of power arrangement in the requested central office, BellSouth may seek a waiver of these requirements from the Commission for the central office requested. Clearwave Communications would still have the option to order its power needs directly from BellSouth.

- 8.6.6 If Clearwave Communications requests a reduction in the amount of power that BellSouth is currently providing, Clearwave Communications must submit a Subsequent Application. If no modification to the Collocation Space is requested other than the reduction in power, the Subsequent Application Fee for Power Reduction as set forth in Exhibit B will apply. If modifications are requested in addition to the reduction of power, the Subsequent Application Fee will apply. BellSouth will bill this nonrecurring fee on the date that BellSouth provides an Application Response.
- 8.6.7 In Alabama and Louisiana, if Clearwave Communications is currently served from the BellSouth main power board and requests that its power be reconfigured to connect to a BellSouth BDFB, in a specific central office, Clearwave Communications must submit a Subsequent Application. BellSouth will respond to such application within seven (7) calendar days and no application fee will apply.
- 8.7 Security Escort. A security escort will be required whenever Clearwave Communications or its approved agent desires access to the entrance manhole or must have access to the Premises after the one accompanied site visit allowed pursuant to Section 5 prior to completing BellSouth's Security Training requirements. Rates for a security escort are assessed according to the schedule appended hereto as Exhibit B beginning with the scheduled escort time. BellSouth will wait for one-half (1/2) hour after the scheduled time for such an escort and Clearwave Communications shall pay for such half-hour charges in the event Clearwave Communications fails to show up.
- 8.8 Cable Record charges. These charges apply for work required to build cable records in BellSouth systems. The VG/DSO per cable record charge is for a maximum of 3600 records. The Fiber cable record charge is for a maximum of 99 records. These nonrecurring fees will be billed upon receipt of Clearwave Communications's BFFO.
- 8.9 Other. If no rate is identified in the contract, the rate for the specific service or function will be negotiated by the Parties upon request by either Party.

## **9. Insurance**

- 9.1 Clearwave Communications shall, at its sole cost and expense, procure, maintain, and keep in force insurance as specified in this Section and underwritten by insurance companies licensed to do business in the states applicable under this Agreement and having a Best's Insurance Rating of A-.
- 9.2 Clearwave Communications shall maintain the following specific coverage:
- 9.2.1 Commercial General Liability coverage in the amount of ten million dollars (\$10,000,000.00) or a combination of Commercial General Liability and Excess/Umbrella coverage totaling not less than ten million dollars (\$10,000,000.00). BellSouth shall be named as an Additional Insured on the Commercial General Liability policy as specified herein.

- 9.2.2 Statutory Workers Compensation coverage and Employers Liability coverage in the amount of one hundred thousand dollars (\$100,000.00) each accident, one hundred thousand dollars (\$100,000.00) each employee by disease, and five hundred thousand dollars (\$500,000.00) policy limit by disease.
- 9.2.3 All Risk Property coverage on a full replacement cost basis insuring all of Clearwave Communications's real and personal property situated on or within BellSouth's Central Office location(s).
- 9.2.4 Clearwave Communications may elect to purchase business interruption and contingent business interruption insurance, having been advised that BellSouth assumes no liability for loss of profit or revenues should an interruption of service occur.
- 9.3 The limits set forth in Section 9.2 above may be increased by BellSouth from time to time during the term of this Agreement upon thirty (30) calendar days notice to Clearwave Communications to at least such minimum limits as shall then be customary with respect to comparable occupancy of BellSouth structures.
- 9.4 All policies purchased by Clearwave Communications shall be deemed to be primary and not contributing to or in excess of any similar coverage purchased by BellSouth. All insurance must be in effect on or before the date equipment is delivered to Premises and shall remain in effect for the term of this Attachment or until all Clearwave Communications's property has been removed from BellSouth's Premises, whichever period is longer. If Clearwave Communications fails to maintain required coverage, BellSouth may pay the premiums thereon and seek reimbursement of same from Clearwave Communications.
- 9.5 Clearwave Communications shall submit certificates of insurance reflecting the coverage required pursuant to this Section a minimum of ten (10) business days prior to the commencement of any work in the Collocation Space. Failure to meet this interval may result in construction and equipment installation delays. Clearwave Communications shall arrange for BellSouth to receive thirty (30) business days' advance notice of cancellation from Clearwave Communications's insurance company. Clearwave Communications shall forward a certificate of insurance and notice of cancellation/non-renewal to BellSouth at the following address:
- BellSouth Telecommunications, Inc.  
Attn.: Risk Management Coordinator  
17H53 BellSouth Center  
675 W. Peachtree Street  
Atlanta, Georgia 30375
- 9.6 Clearwave Communications must conform to recommendations made by BellSouth's fire insurance company to the extent BellSouth has agreed to, or shall hereafter agree to, such recommendations.

- 9.7 **Self-Insurance.** If Clearwave Communications's net worth exceeds five hundred million dollars (\$500,000,000), Clearwave Communications may elect to request self-insurance status in lieu of obtaining any of the insurance required in Sections 9.2.1 and 9.2.2. Clearwave Communications shall provide audited financial statements to BellSouth thirty (30) calendar days prior to the commencement of any work in the Collocation Space. BellSouth shall then review such audited financial statements and respond in writing to Clearwave Communications in the event that self-insurance status is not granted to Clearwave Communications. If BellSouth approves Clearwave Communications for self-insurance, Clearwave Communications shall annually furnish to BellSouth, and keep current, evidence of such net worth that is attested to by one of Clearwave Communications's corporate officers. The ability to self-insure shall continue so long as the Clearwave Communications meets all of the requirements of this Section. If Clearwave Communications subsequently no longer satisfies this Section, Clearwave Communications is required to purchase insurance as indicated by Sections 9.2.1 and 9.2.2.
- 9.8 The net worth requirements set forth in Section 9.7 may be increased by BellSouth from time to time during the term of this Attachment upon thirty (30) calendar days' notice to Clearwave Communications to at least such minimum limits as shall then be customary with respect to comparable occupancy of BellSouth structures.
- 9.9 Failure to comply with the provisions of this Section will be deemed a material breach of this Attachment.

## **10. Mechanics Liens**

- 10.1 If any mechanics lien or other liens shall be filed against property of either Party (BellSouth or Clearwave Communications), or any improvement thereon by reason of or arising out of any labor or materials furnished or alleged to have been furnished or to be furnished to or for the other Party or by reason of any changes, or additions to said property made at the request or under the direction of the other Party, the other Party directing or requesting those changes shall, within thirty (30) business days after receipt of written notice from the Party against whose property said lien has been filed, either pay such lien or cause the same to be bonded off the affected property in the manner provided by law. The Party causing said lien to be placed against the property of the other shall also defend, at its sole cost and expense, on behalf of the other, any action, suit or proceeding which may be brought for the enforcement of such liens and shall pay any damage and discharge any judgment entered thereon.

## **11. Inspections**

- 11.1 BellSouth may conduct an inspection of Clearwave Communications's equipment and facilities in the Collocation Space(s) prior to the activation of facilities between Clearwave Communications's equipment and equipment of BellSouth. BellSouth may conduct an inspection if Clearwave Communications adds equipment and may

otherwise conduct routine inspections at reasonable intervals mutually agreed upon by the Parties. BellSouth shall provide Clearwave Communications with a minimum of forty-eight (48) hours or two (2) business days, whichever is greater, advance notice of all such inspections. All costs of such inspection shall be borne by BellSouth.

## **12. Security and Safety Requirements**

- 12.1 Unless otherwise specified, Clearwave Communications will be required, at its own expense, to conduct a statewide investigation of criminal history records for each Clearwave Communications employee hired in the past five years being considered for work on the Premises, for the states/counties where the Clearwave Communications employee has worked and lived for the past five years. Where state law does not permit statewide collection or reporting, an investigation of the applicable counties is acceptable. Clearwave Communications shall not be required to perform this investigation if an affiliated company of Clearwave Communications has performed an investigation of the Clearwave Communications employee seeking access, if such investigation meets the criteria set forth above. This requirement will not apply if Clearwave Communications has performed a pre-employment statewide investigation of criminal history records of the Clearwave Communications employee for the states/counties where the Clearwave Communications employee has worked and lived for the past five years or, where state law does not permit a statewide investigation, an investigation of the applicable counties.
- 12.2 Clearwave Communications will be required to administer to its personnel assigned to the Premises security training either provided by BellSouth, or meeting criteria defined by BellSouth.
- 12.3 Clearwave Communications shall provide its employees and agents with picture identification, which must be worn and visible at all times while in the Collocation Space or other areas in or around the Premises. The photo identification card shall bear, at a minimum, the employee's name and photo and Clearwave Communications's name. BellSouth reserves the right to remove from its Premises any employee of Clearwave Communications not possessing identification issued by Clearwave Communications or who has violated any of BellSouth's policies as outlined in the CLEC Security Training documents. Clearwave Communications shall hold BellSouth harmless for any damages resulting from such removal of its personnel from BellSouth Premises. Clearwave Communications shall be solely responsible for ensuring that any Guest(s) of Clearwave Communications is in compliance with all subsections of this Section.
- 12.4 Clearwave Communications shall not assign to the Premises any personnel with records of felony criminal convictions. Clearwave Communications shall not assign to the Premises any personnel with records of misdemeanor convictions, except for misdemeanor traffic violations, without advising BellSouth of the nature and gravity of the offense(s). BellSouth reserves the right to refuse building access to any Clearwave Communications personnel who have been identified to have misdemeanor criminal

- convictions. Notwithstanding the foregoing, in the event that Clearwave Communications chooses not to advise BellSouth of the nature and gravity of any misdemeanor conviction, Clearwave Communications may, in the alternative, certify to BellSouth that it shall not assign to the Premises any personnel with records of misdemeanor convictions (other than misdemeanor traffic violations).
- 12.4.1 Clearwave Communications shall not knowingly assign to the Premises any individual who was a former employee of BellSouth and whose employment with BellSouth was terminated for a criminal offense whether or not BellSouth sought prosecution of the individual for the criminal offense.
- 12.4.2 Clearwave Communications shall not knowingly assign to the Premises any individual who was a former supplier of BellSouth and whose access to a Premises was revoked due to commission of a criminal offense whether or not BellSouth sought prosecution of the individual for the criminal offense.
- 12.5 For each Clearwave Communications employee or agent hired by Clearwave Communications within five years of being considered for work on the Premises, who requires access to a Premises pursuant to this Attachment, Clearwave Communications shall furnish BellSouth, prior to an employee or agent gaining such access, a certification that the aforementioned background check and security training were completed. The certification will contain a statement that no felony convictions were found and certify that the employee completed the security training. If the employee's criminal history includes misdemeanor convictions, Clearwave Communications will disclose the nature of the convictions to BellSouth at that time. In the alternative, Clearwave Communications may certify to BellSouth that it shall not assign to the Premises any personnel with records of misdemeanor convictions other than misdemeanor traffic violations.
- 12.5.1 For all other Clearwave Communications employees requiring access to a Premises pursuant to this Attachment, Clearwave Communications shall furnish BellSouth, prior to an employee gaining such access, a certification that the employee is not subject to the requirements of Section 12.5 above and that security training was completed by the employee.
- 12.6 At BellSouth's request, Clearwave Communications shall promptly remove from Premises any employee of Clearwave Communications BellSouth does not wish to grant access to its Premises 1) pursuant to any investigation conducted by BellSouth or 2) prior to the initiation of an investigation if an employee of Clearwave Communications is found interfering with the property or personnel of BellSouth or another collocated telecommunications carrier, provided that an investigation shall promptly be commenced by BellSouth.
- 12.7 Security Violations. BellSouth reserves the right to interview Clearwave Communications's employees, agents, or suppliers in the event of wrongdoing in or around BellSouth's property or involving BellSouth's or another collocated telecommunications carrier's property or personnel, provided that BellSouth shall

provide reasonable notice to Clearwave Communications's Security representative of such interview. Clearwave Communications and its suppliers shall reasonably cooperate with BellSouth's investigation into allegations of wrongdoing or criminal conduct committed by, witnessed by, or involving Clearwave Communications's employees, agents, or suppliers. Additionally, BellSouth reserves the right to bill Clearwave Communications for all reasonable costs associated with investigations involving its employees, agents, or suppliers if it is established and mutually agreed in good faith that Clearwave Communications's employees, agents, or suppliers are responsible for the alleged act. BellSouth shall bill Clearwave Communications for BellSouth property, which is stolen or damaged where an investigation determines the culpability of Clearwave Communications's employees, agents, or suppliers and where Clearwave Communications agrees, in good faith, with the results of such investigation. Clearwave Communications shall notify BellSouth in writing immediately in the event that Clearwave Communications discovers one of its employees already working on the Premises is a possible security risk. Upon request of the other Party, the Party who is the employer shall discipline consistent with its employment practices, up to and including removal from BellSouth's Premises, any employee found to have violated the security and safety requirements of this Section. Clearwave Communications shall hold BellSouth harmless for any damages resulting from such removal of its personnel from Premises.

- 12.8 Use of Supplies. Unauthorized use of equipment, supplies or other property by either Party, whether or not used routinely to provide telephone service will be strictly prohibited and handled appropriately. Costs associated with such unauthorized use may be charged to the offending Party, as may be all associated investigative costs.
- 12.9 Use of Official Lines. Except for non-toll calls necessary in the performance of their work, neither Party shall use the telephones of the other Party on the Premises. Charges for unauthorized telephone calls may be charged to the offending Party, as may be all associated investigative costs.
- 12.10 Accountability. Full compliance with the Security requirements of this Section shall in no way limit the accountability of either Party to the other for the improper actions of its employees.

### **13. Destruction of Collocation Space**

- 13.1 In the event a Collocation Space is wholly or partially damaged by fire, windstorm, tornado, flood or by similar causes to such an extent as to be rendered wholly unsuitable for Clearwave Communications's permitted use hereunder, then either Party may elect within ten (10) calendar days after such damage, to terminate occupancy of the damaged Collocation Space, and if either Party shall so elect, by giving the other written notice of termination, both Parties shall stand released of and from further liability under the terms hereof. If the Collocation Space shall suffer only minor damage and shall not be rendered wholly unsuitable for Clearwave Communications's permitted use, or is damaged and the option to terminate is not exercised by either



Party, BellSouth covenants and agrees to proceed promptly without expense to Clearwave Communications, except for improvements not to the property of BellSouth, to repair the damage. BellSouth shall have a reasonable time within which to rebuild or make any repairs, and such rebuilding and repairing shall be subject to delays caused by storms, shortages of labor and materials, government regulations, strikes, walkouts, and causes beyond the control of BellSouth, which causes shall not be construed as limiting factors, but as exemplary only. Clearwave Communications may, at its own expense, accelerate the rebuild of its collocated space and equipment provided however that a BellSouth Certified Supplier is used and the necessary space preparation has been completed. If Clearwave Communications's acceleration of the project increases the cost of the project, then those additional charges will be incurred by Clearwave Communications. Where allowed and where practical, Clearwave Communications may erect a temporary facility while BellSouth rebuilds or makes repairs. In all cases where the Collocation Space shall be rebuilt or repaired, Clearwave Communications shall be entitled to an equitable abatement of rent and other charges, depending upon the unsuitability of the Collocation Space for Clearwave Communications's permitted use, until such Collocation Space is fully repaired and restored and Clearwave Communications's equipment installed therein (but in no event later than thirty (30) calendar days after the Collocation Space is fully repaired and restored). Where Clearwave Communications has placed an Adjacent Arrangement pursuant to Section 3.4, Clearwave Communications shall have the sole responsibility to repair or replace said Adjacent Arrangement provided herein. Pursuant to this Section, BellSouth will restore the associated services to the Adjacent Arrangement.

**14. Eminent Domain**

- 14.1 If the whole of a Collocation Space or Adjacent Arrangement shall be taken by any public authority under the power of eminent domain, then this Attachment shall terminate with respect to such Collocation Space or Adjacent Arrangement as of the day possession shall be taken by such public authority and rent and other charges for the Collocation Space or Adjacent Arrangement shall be paid up to that day with proportionate refund by BellSouth of such rent and charges as may have been paid in advance for a period subsequent to the date of the taking. If any part of the Collocation Space or Adjacent Arrangement shall be taken under eminent domain, BellSouth and Clearwave Communications shall each have the right to terminate this Attachment with respect to such Collocation Space or Adjacent Arrangement and declare the same null and void, by written notice of such intention to the other Party within ten (10) calendar days after such taking.

**15. Nonexclusivity**

- 15.1 Clearwave Communications understands that this Attachment is not exclusive and that BellSouth may enter into similar agreements with other Parties. Assignment of space

pursuant to all such agreements shall be determined by space availability and made on a first come, first served basis

## **ENVIRONMENTAL AND SAFETY PRINCIPLES**

The following principles provide basic guidance on environmental and safety issues when applying for and establishing Physical Collocation arrangements.

### **1. GENERAL PRINCIPLES**

- 1.1 Compliance with Applicable Law. BellSouth and Clearwave Communications agree to comply with applicable federal, state, and local environmental and safety laws and regulations including U.S. Environmental Protection Agency (USEPA) regulations issued under the Clean Air Act (CAA), Clean Water Act (CWA), Resource Conservation and Recovery Act (RCRA), Comprehensive Environmental Response, Compensation and Liability Act (CERCLA), Superfund Amendments and Reauthorization Act (SARA), the Toxic Substances Control Act (TSCA), and OSHA regulations issued under the Occupational Safety and Health Act of 1970, as amended and NFPA and National Electrical Codes (NEC) and the NESC (Applicable Laws). Each Party shall notify the other if compliance inspections are conducted by regulatory agencies and/or citations are issued that relate to any aspect of this Attachment.
- 1.2 Notice. BellSouth and Clearwave Communications shall provide notice to the other, including Material Safety Data Sheets (MSDSs), of known and recognized physical hazards or Hazardous Chemicals existing on site or brought on site. A Hazardous Chemical inventory list is posted on an OSHA Poster and updated annually at each Central Office. This Poster is normally located near the front entrance of the building or in the lounge area. Each Party is required to provide specific notice for known potential Imminent Danger conditions. Clearwave Communications should contact 1-800-743-6737 for any BellSouth MSDS required.
- 1.3 Practices/Procedures. BellSouth may make available additional environmental control procedures for Clearwave Communications to follow when working at a Premises (See Section 2, below). These practices/procedures will represent the regular work practices required to be followed by the employees and suppliers of BellSouth for environmental protection. Clearwave Communications will require its suppliers, agents and others accessing the Premises to comply with these practices. Section 2 lists the Environmental categories where BST practices should be followed by Clearwave Communications when operating in the Premises.
- 1.4 Environmental and Safety Inspections. BellSouth reserves the right to inspect the Clearwave Communications space with proper notification. BellSouth reserves the right to stop any Clearwave Communications work operation that imposes Imminent Danger to the environment, employees or other persons in the area or Premises.
- 1.5 Hazardous Materials Brought On Site. Any hazardous materials brought into, used, stored or abandoned at the Premises by Clearwave Communications are owned by Clearwave Communications. Clearwave Communications will indemnify BellSouth for claims, lawsuits or damages to persons or property caused by these materials. Without prior written BellSouth approval, no substantial new safety or environmental hazards can be created by Clearwave Communications or different hazardous materials used by Clearwave Communications at Premises. Clearwave Communications must

demonstrate adequate emergency response capabilities for its materials used or remaining at the Premises.

1.6 Spills and Releases. When contamination is discovered at a Premises, either Party discovering the condition must notify the other Party. All Spills or Releases of regulated materials will immediately be reported by Clearwave Communications to BellSouth.

1.7 Coordinated Environmental Plans and Permits. BellSouth and Clearwave Communications will coordinate plans, permits or information required to be submitted to government agencies, such as emergency response plans, spill prevention control and countermeasures (SPCC) plans and community reporting. If fees are associated with filing, BellSouth and Clearwave Communications will develop a cost sharing procedure. If BellSouth's permit or EPA identification number must be used, Clearwave Communications must comply with all of BellSouth's permit conditions and environmental processes, including environmental "best management practices (BMP)" (see Section 2, below) and/or selection of BST disposition vendors and disposal sites.

1.8 Environmental and Safety Indemnification. BellSouth and Clearwave Communications shall indemnify, defend and hold harmless the other Party from and against any claims (including, without limitation, third-party claims for personal injury or death or real or personal property damage), judgments, damages (including direct and indirect damages and punitive damages), penalties, fines, forfeitures, costs, liabilities, interest and losses arising in connection with the violation or alleged violation of any Applicable Law or contractual obligation or the presence or alleged presence of contamination arising out of the acts or omissions of the indemnifying Party, its agents, suppliers, or employees concerning its operations at the Premises.

## 2. **CATEGORIES FOR CONSIDERATION OF ENVIRONMENTAL ISSUES**

2.1 When performing functions that fall under the following Environmental categories on BellSouth's Premises, Clearwave Communications agrees to comply with the applicable sections of the current issue of BellSouth's Environmental and Safety Methods and Procedures (M&Ps), incorporated herein by this reference. Clearwave Communications further agrees to cooperate with BellSouth to ensure that Clearwave Communications's employees, agents, and/or suppliers are knowledgeable of and satisfy those provisions of BellSouth's Environmental M&Ps which apply to the specific Environmental function being performed by Clearwave Communications, its employees, agents and/or suppliers.

2.2 The most current version of the reference documentation must be requested from Clearwave Communications's BellSouth Regional Contract Manager (RCM) (f/k/a Account Team Collocation Coordinator – ATCC).

ENVIRONMENTAL CATEGORIES	ENVIRONMENTAL ISSUES	ADDRESSED BY THE FOLLOWING DOCUMENTATION
Disposal of hazardous material or other regulated material (e.g., batteries, fluorescent tubes, solvents & cleaning materials)	Compliance with all applicable local, state, & federal laws and regulations  Pollution liability insurance  EVET approval of supplier	Std T&C 450 Fact Sheet Series 17000  Std T&C 660-3  Approved Environmental Vendor List (Contact RCM Representative)
Emergency response	Hazmat/waste release/spill fire safety emergency	Fact Sheet Series 17000 Building Emergency Operations Plan (EOP) (specific to and located on Premises)
Contract labor/outsourcing for services with environmental implications to be performed on BellSouth Premises (e.g., disposition of hazardous material/waste; maintenance of storage tanks)	Compliance with all applicable local, state, & federal laws and regulations  Performance of services in accordance with BST's environmental M&Ps  Insurance	Std T&C 450  Std T&C 450-B (Contact RCM Representative for copy of appropriate E/S M&Ps.)  Std T&C 660
Transportation of hazardous material	Compliance with all applicable local, state, & federal laws and regulations  Pollution liability insurance  EVET approval of supplier	Std T&C 450 Fact Sheet Series 17000  Std T&C 660-3  Approved Environmental Vendor List (Contact RCM Representative)
Maintenance/operations work which may produce a waste  Other maintenance work	Compliance with all applicable local, state, & federal laws and regulations  Protection of BST employees and equipment	Std T&C 450  29CFR 1910.147 (OSHA Standard) 29CFR 1910 Subpart O

		(OSHA Standard)
Janitorial services	All waste removal and disposal must conform to all applicable federal, state and local regulations  All Hazardous Material and Waste  Asbestos notification and protection of employees and equipment	Procurement Manager (CRES Related Matters)-BST Supply Chain Services  Fact Sheet Series 17000  GU-BTEN-001BT, Chapter 3 BSP 010-170-001BS (Hazcom)
Manhole cleaning	Compliance with all applicable local, state, & federal laws and regulations  Pollution liability insurance  EVET approval of supplier	Std T&C 450 Fact Sheet 14050 BSP 620-145-011PR Issue A, August 1996  Std T&C 660-3  Approved Environmental Vendor List (Contact RCM Representative)
Removing or disturbing building materials that may contain asbestos	Asbestos work practices	GU-BTEN-001BT, Chapter 3 For questions regarding removing or disturbing materials that contain asbestos, call the BellSouth Building Service Center: AL, MS, TN, KY & LA (local area code) 557-6194 FL, GA, NC & SC (local area code) 780-2740

### 3. DEFINITIONS

Generator. Under RCRA, the person whose act produces a Hazardous Waste, as defined in 40 CFR 261, or whose act first causes a Hazardous Waste to become subject to regulation. The Generator is legally responsible for the proper management and disposal of Hazardous Wastes in accordance with regulations.

Hazardous Chemical. As defined in the U.S. Occupational Safety and Health (OSHA) hazard communication standard (29 CFR 1910.1200), any chemical which is a health hazard or physical hazard.

Hazardous Waste. As defined in Section 1004 of RCRA.

Imminent Danger. Any conditions or practices at a Premises which are such that a danger exists which could reasonably be expected to cause immediate death or serious harm to people or immediate significant damage to the environment or natural resources.

Spill or Release. As defined in Section 101 of CERCLA.

#### **4. ACRONYMS**

RCM – Regional Collocation Manager (f/k/a Account Team Collocation Coordinator)

BST – BellSouth Telecommunications

CRES – Corporate Real Estate and Services (formerly PS&M)

DEC/LDEC - Department Environmental Coordinator/Local Department Environmental Coordinator

E/S – Environmental/Safety

EVET - Environmental Vendor Evaluation Team

GU-BTEN-001BT - BellSouth Environmental Methods and Procedures

NESC - National Electrical Safety Codes

P&SM - Property & Services Management

Std T&C - Standard Terms & Conditions

## **Attachment 4**

### **Remote Site Physical Collocation**



## BELLSOUTH

### REMOTE SITE PHYSICAL COLLOCATION

#### 1. Scope of Attachment

- 1.1 Scope of Attachment. The rates, terms, and conditions contained within this Attachment shall only apply when Clearwave Communications is occupying the collocation space as a sole occupant or as a Host within a Remote Site Location (“Remote Collocation Space”) pursuant to this Attachment.
- 1.2 Right to occupy. BellSouth shall offer to Clearwave Communications Remote Collocation Space on rates, terms, and conditions that are just, reasonable, non-discriminatory and consistent with the rules of the Federal Communications Commission (“FCC”). Subject to the rates, terms, and conditions of this Attachment, where space is available and collocation is technically feasible, BellSouth will allow Clearwave Communications to occupy that certain area designated by BellSouth within a BellSouth Remote Site Location, or on BellSouth property upon which the BellSouth Remote Site Location is located, of a size, which is specified by Clearwave Communications and agreed to by BellSouth. BellSouth Remote Site Locations include cabinets, huts, and controlled environmental vaults owned or leased by BellSouth that house BellSouth Network Facilities. To the extent this Attachment does not include all the necessary rates, terms and conditions for BellSouth Remote Site Locations other than cabinets, huts and controlled environmental vaults, the Parties will negotiate said rates, terms, and conditions upon request for collocation at BellSouth Remote Site Locations other than those specified above.
- 1.3 Space Reservation.
- 1.3.1 In all states other than Florida, the number of racks/bays specified by Clearwave Communications may contemplate a request for space sufficient to accommodate Clearwave Communications’s growth within a two-year period.
- 1.3.2 In the state of Florida, the number of racks/bays specified by Clearwave Communications may contemplate a request for space sufficient to accommodate Clearwave Communications’s growth within an eighteen (18) month period.
- 1.3.3 Neither BellSouth nor any of BellSouth’s affiliates may reserve space for future use on more preferential terms than those set forth above.
- 1.4 Third Party Property. If the Premises, or the property on which it is located, is leased by BellSouth from a Third Party or otherwise controlled by a Third Party, special

- considerations and intervals may apply in addition to the terms and conditions of this Attachment. Additionally, where BellSouth notifies Clearwave Communications that BellSouth's agreement with a Third Party does not grant BellSouth the ability to provide access and use rights to others, upon Clearwave Communications's request, BellSouth will use its best efforts to obtain the owner's consent and to otherwise secure such rights for Clearwave Communications. Clearwave Communications agrees to reimburse BellSouth for the reasonable and demonstrable costs incurred by BellSouth in obtaining such rights for Clearwave Communications. In cases where a Third Party agreement does not grant BellSouth the right to provide access and use rights to others as contemplated by this Attachment and BellSouth, despite its best efforts, is unable to secure such access and use rights for Clearwave Communications as above, Clearwave Communications shall be responsible for obtaining such permission to access and use such property. BellSouth shall cooperate with Clearwave Communications in obtaining such permission.
- 1.5 Space Reclamation. In the event of space exhaust within a Remote Site Location, BellSouth may include in its documentation for the Petition for Waiver filing any unutilized space in the Remote Site Location. Clearwave Communications will be responsible for any justification of unutilized space within its Remote Collocation Space, if the Commission requires such justification.
- 1.6 Use of Space. Clearwave Communications shall use the Remote Collocation Space for the purposes of installing, maintaining and operating Clearwave Communications's equipment (to include testing and monitoring equipment) necessary for interconnection with BellSouth services and facilities or for accessing BellSouth unbundled network elements (UNEs) for the provision of telecommunications services, as specifically set forth in this Agreement. The Remote Collocation Space may be used for no other purposes except as specifically described herein or in any amendment hereto.
- 1.7 Rates and charges. Clearwave Communications agrees to pay the rates and charges identified in Exhibit B attached hereto.
- 1.8 If any due date contained in this Attachment falls on a weekend or National holiday, then the due date will be the next business day thereafter. For intervals of ten (10) calendar days or less National holidays will be excluded.
- 1.9 The Parties agree to comply with all applicable federal, state, county, local and administrative laws, rules, ordinances, regulations and codes in the performance of their obligations hereunder.
- 2. Space Availability Report**
- 2.1 Space Availability Report. Upon request from Clearwave Communications, BellSouth will provide a written report ("Space Availability Report"), describing in detail the space that is available for collocation and specifying the amount of Remote

- Collocation Space available at the Remote Site Location requested, the number of collocators present at the Remote Site Location, any modifications in the use of the space since the last report on the Remote Site Location requested and the measures BellSouth is taking to make additional space available for collocation arrangements. A Space Availability Report does not reserve space at the Remote Site Location.
- 2.1.1 The request from Clearwave Communications for a Space Availability Report must be written and must include the Common Language Location Identification (“CLLI”) code for both the Remote Site Location and the serving wire center. The CLLI code information for the serving wire center is located in the National Exchange Carrier Association (NECA) Tariff FCC No. 4. If Clearwave Communications is unable to obtain the CLLI code for the Remote Site Location from, for example, a site visit to the remote site, Clearwave Communications may request the CLLI code from BellSouth. To obtain a CLLI code for a Remote Site Location directly from BellSouth, Clearwave Communications should submit to BellSouth a Remote Site Interconnection Request for the serving wire center CLLI code prior to submitting its request for a Space Availability Report. Clearwave Communications should complete all the requested information and submit the Request to BellSouth. BellSouth will bill the applicable fee upon receipt of the request.
- 2.1.2 BellSouth will respond to a request for a Space Availability Report for a particular Remote Site Location within ten (10) calendar days of receipt of such request. BellSouth will make best efforts to respond in ten (10) calendar days to such a request when the request includes from two (2) to five (5) Remote Site Locations within the same state. The response time for requests of more than five (5) Remote Site Locations shall be negotiated between the Parties. If BellSouth cannot meet the ten (10) calendar day response time, BellSouth shall notify Clearwave Communications and inform Clearwave Communications of the time frame under which it can respond.
- 2.2 Remote Terminal information. Upon request, BellSouth will provide Clearwave Communications with the following information concerning BellSouth’s remote terminals: (i) the address of the remote terminal; (ii) the CLLI code of the remote terminal; (iii) the carrier serving area of the remote terminal; (iv) the designation of which remote terminals subtend a particular central office; and (v) the number and address of customers that are served by a particular remote terminal.
- 2.2.1 BellSouth will provide this information on a first come, first served basis within thirty (30) calendar days of a Clearwave Communications request subject to the following conditions: (i) the information will only be provided on a CD in the same format in which it appears in BellSouth’s systems; (ii) the information will only be provided for each serving wire center designated by Clearwave Communications, up to a maximum of thirty (30) wire centers per Clearwave Communications request per month per state, and up to for a maximum of one hundred twenty (120) wire centers total per month per state for all CLECs; and (iii) Clearwave Communications agrees to pay the costs incurred by BellSouth in providing the information.

### **3. Collocation Options**

- 3.1 Cageless. BellSouth shall allow Clearwave Communications to collocate Clearwave Communications's equipment and facilities without requiring the construction of a cage or similar structure. BellSouth shall allow Clearwave Communications to have direct access to Clearwave Communications's equipment and facilities in accordance with Section 5.8. BellSouth shall make cageless collocation available in single rack/bay increments. Except where Clearwave Communications's equipment requires special technical considerations (e.g., special cable racking or isolated ground plane), BellSouth shall assign cageless Remote Collocation Space in conventional equipment rack lineups where feasible. For equipment requiring special technical considerations, Clearwave Communications must provide the equipment layout, including spatial dimensions for such equipment pursuant to generic requirements contained in Telcordia GR-63-Core, and shall be responsible for compliance with all special technical requirements associated with such equipment pursuant to Section 7.6 following.
- 3.2 Caged. At Clearwave Communications's expense, Clearwave Communications may arrange with a Supplier certified by BellSouth ("BellSouth Certified Supplier") to construct a collocation arrangement enclosure, where technically feasible as that term has been defined by the FCC, in accordance with BellSouth's Technical References (TR) ("Specifications") prior to starting equipment installation. BellSouth will provide Specifications upon request. Clearwave Communications's BellSouth Certified Supplier shall be responsible for filing and receiving any and all necessary permits and/or licenses for such construction. BellSouth shall cooperate with Clearwave Communications and provide, at Clearwave Communications's expense, the documentation, including existing building architectural drawings, enclosure drawings, and Specifications required and necessary for Clearwave Communications's BellSouth Certified Supplier to obtain the zoning, permits and/or other licenses. Clearwave Communications's BellSouth Certified Supplier shall bill Clearwave Communications directly for all work performed for Clearwave Communications pursuant to this Attachment and BellSouth shall have no liability for nor responsibility to pay such charges imposed by Clearwave Communications's BellSouth Certified Supplier. Clearwave Communications must provide the local BellSouth Remote Site Location contact with two Access Keys used to enter the locked enclosure. Except in case of emergency, BellSouth will not access Clearwave Communications's locked enclosure prior to notifying Clearwave Communications at least forty-eight (48) hours before access to the Remote Site Location is required. Upon request, BellSouth shall construct the enclosure for Clearwave Communications.
- 3.2.1 BellSouth may elect to review Clearwave Communications's plans and specifications prior to allowing construction to start to ensure compliance with BellSouth's Specifications. Notification to Clearwave Communications indicating BellSouth's desire to execute this review will be provided in BellSouth's response to the Application, if Clearwave Communications has indicated their desire to construct their

own enclosure. If Clearwave Communications's Application does not indicate their desire to construct their own enclosure, but their firm order does indicate their desire to construct their own enclosure, then notification to review will be given within ten (10) calendar days after the Firm Order date. BellSouth shall complete its review within fifteen (15) calendar days after the receipt of the plans and specifications. Regardless of whether or not BellSouth elects to review Clearwave Communications's plans and specifications, BellSouth reserves the right to inspect the enclosure after construction to make sure it is constructed according to the submitted plans and specifications and/or BellSouth's Specifications, as applicable. BellSouth shall require Clearwave Communications to remove or correct within seven (7) calendar days at Clearwave Communications's expense any structure that does not meet these plans and specifications or, where applicable, BellSouth's Specifications.

3.3 Shared Collocation. Clearwave Communications may allow other telecommunications carriers to share Clearwave Communications's Remote Collocation Space pursuant to terms and conditions agreed to by Clearwave Communications ("Host") and other telecommunications carriers ("Guests") and pursuant to this Section, except where the BellSouth Remote Site Location is located within a leased space and BellSouth is prohibited by said lease from offering such an option or is located on property for which BellSouth holds an easement and such easement does not permit such an option. Clearwave Communications shall notify BellSouth in writing upon execution of any agreement between the Host and its Guest within ten (10) calendar days of its execution and prior to any Firm Order. Further, such notice shall include the name of the Guest(s) and the term of the agreement, and shall contain a certification by Clearwave Communications that said agreement imposes upon the Guest(s) the same terms and conditions for Remote Collocation Space as set forth in this Attachment between BellSouth and Clearwave Communications.

3.3.1 Clearwave Communications, as the Host, shall be the sole interface and responsible Party to BellSouth for assessment of rates and charges contained within this Attachment and for the purposes of ensuring that the safety and security requirements of this Attachment are fully complied with by the Guest, its employees and agents. BellSouth shall provide Clearwave Communications with a proration of the costs of the Remote Collocation Space based on the number of collocators and the space used by each with a minimum charge of one (1) bay/rack per Host/Guest. In those instances where the Host permits a Guest to use a shelf within the Host's bay, BellSouth will not prorate the cost of the bay. In all states other than Florida, and in addition to the foregoing, Clearwave Communications shall be the responsible party to BellSouth for the purpose of submitting applications for bay/rack placement for the Guest. In Florida the Guest may directly submit bay/rack placement applications using the Host's access carrier name abbreviation (ACNA). A separate Guest application shall require the assessment of an Application Fee, as set forth in Exhibit B, which will be charged to the Host. BellSouth shall bill this nonrecurring fee on the date that BellSouth provides it written response ("Application Response").

- 3.3.2 Notwithstanding the foregoing, the Guest may arrange directly with BellSouth for the provision of the interconnecting facilities between BellSouth and the Guest and for the provision of the services and access to unbundled network elements. The bill for these interconnecting facilities, services and access to UNEs will be charged to the Guest pursuant to the applicable tariff or the Guest's Interconnection Agreement with BellSouth.
- 3.3.3 Clearwave Communications shall indemnify and hold harmless BellSouth from any and all claims, actions, causes of action, of whatever kind or nature arising out of the presence of Clearwave Communications's Guest(s) in the Remote Collocation Space except to the extent caused by BellSouth's sole negligence, gross negligence, or willful misconduct.
- 3.4 Adjacent Collocation. Subject to technical feasibility and space availability, BellSouth will permit adjacent Remote Site collocation arrangements ("Remote Site Adjacent Arrangement") on the property on which the Remote Site is located when space within the Remote Site Location is legitimately exhausted, where the Remote Site Adjacent Arrangement does not interfere with access to existing or planned structures or facilities on the Remote Site Location property. The Remote Site Adjacent Arrangement shall be constructed or procured by Clearwave Communications and in conformance with BellSouth's design and construction Specifications. Further, Clearwave Communications shall construct, procure, maintain and operate said Remote Site Adjacent Arrangement(s) pursuant to all of the terms and conditions set forth in this Attachment. Rates shall be negotiated at the time of the application for the Remote Site Adjacent Arrangement.
- 3.4.1 Should Clearwave Communications elect Adjacent Collocation, Clearwave Communications must arrange with a BellSouth Certified Supplier to construct a Remote Site Adjacent Arrangement structure in accordance with BellSouth's Specifications. Where local building codes require enclosure specifications more stringent than BellSouth's Specifications, Clearwave Communications and Clearwave Communications's BellSouth Certified Supplier must comply with local building code requirements. Clearwave Communications's BellSouth Certified Supplier shall be responsible for filing and receiving any and all necessary zoning, permits and/or licenses for such construction. Clearwave Communications's BellSouth Certified Supplier shall bill Clearwave Communications directly for all work performed for Clearwave Communications pursuant to this Attachment and BellSouth shall have no liability for nor responsibility to pay such charges imposed by Clearwave Communications's BellSouth Certified Supplier. Clearwave Communications must provide the local BellSouth Remote Site Location contact with two cards, keys or other access device used to enter the locked enclosure. Except in cases of emergency, BellSouth shall not access Clearwave Communications's locked enclosure prior to notifying Clearwave Communications at least forty-eight (48) hours or two (2) business days, whichever is greater, before access to the locked enclosure is required.

- 3.4.2 Clearwave Communications must submit its plans and specifications to BellSouth with its Firm Order. BellSouth shall review Clearwave Communications's plans and specifications prior to construction of a Remote Site Adjacent Arrangement(s) to ensure compliance with BellSouth's Specifications. BellSouth shall complete its review within fifteen (15) calendar days after receipt of plans and specifications. BellSouth may inspect the Remote Site Adjacent Arrangement(s) during and after construction to confirm it is constructed according to the submitted plans and specifications. BellSouth shall require Clearwave Communications to remove or correct within seven (7) calendar days at Clearwave Communications's expense any structure that does not meet these plans and specifications or, where applicable, BellSouth's Specifications.
- 3.4.3 Clearwave Communications shall provide a concrete pad, the structure housing the arrangement, heating/ventilation/air conditioning ("HVAC"), lighting, and all facilities that connect the structure (i.e. racking, conduits, etc.) to the BellSouth point of demarcation. At Clearwave Communications's option, and where the local authority having jurisdiction permits, BellSouth shall provide an AC power source and access to physical collocation services and facilities subject to the same nondiscriminatory requirements as applicable to any other physical collocation arrangement. In Alabama and Louisiana, BellSouth will provide DC power to Adjacent Collocation sites where technically feasible, as that term has been defined by the FCC, and subject to individual case basis pricing. Clearwave Communications's BellSouth Certified Supplier shall be responsible, at Clearwave Communications's expense, for filing and receiving any and all necessary zoning, permits and/or licenses for such arrangement. BellSouth shall allow Shared Collocation within a Remote Site Adjacent Arrangement pursuant to the terms and conditions set forth herein.
- 3.5 Co-carrier cross-connect (CCXC). The primary purpose of collocation is for a collocated telecommunications carrier to interconnect with BellSouth's network or to access BellSouth's unbundled network elements for the provision of telecommunications services within a BellSouth Premises. BellSouth will permit Clearwave Communications to interconnect between its virtual or physical collocation arrangements and those of another collocated telecommunications carrier within the same Remote Site Location. Both Clearwave Communications's agreement and the other collocated telecommunications carrier's agreement must contain rates, terms and conditions for CCXC language. At no point in time shall Clearwave Communications use the Remote Collocation Space for the sole or primary purpose of cross connecting to other collocated telecommunications carriers.
- 3.5.1 Clearwave Communications must use a BellSouth Certified Supplier to place the CCXC. The CCXC shall be provisioned through facilities owned by Clearwave Communications. Such connections to other collocated telecommunications carriers may be made using either optical or electrical facilities. In cases where Clearwave Communications's equipment and the equipment of the other collocated telecommunications carrier are located in contiguous caged Collocation Spaces,

- Clearwave Communications will have the option of using Clearwave Communications's own technicians to deploy co-carrier cross connects using either electrical or optical facilities between the sets of equipment and construct its own dedicated cable support structure. Clearwave Communications shall deploy such optical or electrical connections directly between its own facilities and the facilities of other collocated telecommunications carriers without being routed through BellSouth equipment. Clearwave Communications shall not provision CCXC on any BellSouth distribution frame, POT (Point of Termination) Bay, DSX (Digital System Cross-connect) or LGX (Light Guide Cross-connect). Clearwave Communications is responsible for ensuring the integrity of the signal.
- 3.5.2 Clearwave Communications shall be responsible for providing a letter of authorization ("LOA") to BellSouth from the other collocated telecommunications carrier prior to installing the CCXC. Clearwave Communications-provisioned CCXC shall utilize common cable support structure. There will be a recurring charge per linear foot, per cable, of common cable support structure used. In the case of two contiguous caged collocation arrangements, Clearwave Communications will have the option of using Clearwave Communications's own technicians to construct its own dedicated support structure.
- 3.5.3 To order CCXCs, Clearwave Communications must submit an Application. If no modification to the Remote Collocation Space is requested other than the placement of CCXCs, the Subsequent Application Fee for CCXCs, as defined in Exhibit B, will apply. If modifications in addition to the placement of CCXCs are requested, the Application Fee will apply. This nonrecurring fee will be billed by BellSouth on the date that BellSouth provides an Application Response.
4. **Occupancy**
- 4.1 **Occupancy.** BellSouth will notify Clearwave Communications in writing that the Remote Collocation Space is ready for occupancy ("Space Ready Date"). Clearwave Communications will schedule and complete an acceptance walkthrough of each Remote Collocation Space with BellSouth within fifteen (15) calendar days of BellSouth's notifying Clearwave Communications that Remote Collocation Space is ready for occupancy ("Space Ready Date"). BellSouth will correct any deviations to Clearwave Communications's original or jointly amended requirements within seven (7) calendar days after the walkthrough, unless the Parties jointly agree upon a different time frame, and BellSouth shall establish a new Space Ready Date. Another acceptance walkthrough will then be scheduled and conducted within fifteen (15) calendar days of the new Space Ready Date. This follow-up acceptance walkthrough will be limited to those items identified in the initial walkthrough. If Clearwave Communications has met the fifteen (15) calendar day interval(s), billing will begin upon the date of Clearwave Communications's acceptance of the Collocation Space ("Space Acceptance Date"). In the event that Clearwave Communications fails to complete an acceptance walkthrough within this fifteen (15) calendar day interval, the Remote Collocation Space shall be deemed accepted by Clearwave Communications



on the Space Ready Date and billing will commence from that date. If Clearwave Communications decides to occupy the space prior to the Space Ready Date, the date Clearwave Communications occupies the space becomes the new Space Acceptance Date and billing begins from that date. Clearwave Communications must notify BellSouth in writing that collocation equipment installation is complete and is operational with BellSouth's network. BellSouth may, at its option, not accept orders for cross connects until receipt of such notice. For purposes of this paragraph, Clearwave Communications's telecommunications equipment will be deemed operational when cross-connected to BellSouth's network for the purpose of service provision.

4.2 Termination of Occupancy. In addition to any other provisions addressing termination of occupancy in this Attachment, Clearwave Communications may terminate occupancy in a particular Remote Collocation Space by submitting an Application requesting termination of occupancy; such termination shall be effective upon BellSouth's acceptance of the Space Relinquishment Form. Billing for monthly recurring charges will cease on the date Clearwave Communications and BellSouth conduct an inspection of the terminated space and jointly sign off on the Space Relinquishment Form or on the date that Clearwave Communications signs off on the Space Relinquishment Form and sends the form to BellSouth if a subsequent inspection of the terminated space by BellSouth reveals no discrepancies. If the subsequent inspection by BellSouth reveals discrepancies, billing will cease on the date that BellSouth and Clearwave Communications jointly conduct an inspection which confirms that Clearwave Communications has corrected the discrepancies. An Application Fee will not apply for termination of occupancy. BellSouth may terminate Clearwave Communications's right to occupy the Remote Collocation Space in the event Clearwave Communications fails to comply with any provision of this Agreement.

4.2.1 Upon termination of occupancy, Clearwave Communications at its expense shall remove its equipment and other property from the Remote Collocation Space. Clearwave Communications shall have thirty (30) calendar days from the Bona Fide Firm Order ("BFFO") Application Date ("Termination Date") to complete such removal, including the removal of all equipment and facilities of Clearwave Communications's Guest(s), unless Clearwave Communications's Guest(s) has assumed responsibility for the Remote Collocation Space housing the Guest(s)'s equipment and executed the documentation required by BellSouth prior to such removal date. Clearwave Communications shall continue payment of monthly fees to BellSouth until such date as Clearwave Communications, and if applicable Clearwave Communications's Guest(s), has fully vacated the Remote Collocation Space and the Space Relinquish Form has been accepted by BellSouth. Should Clearwave Communications or Clearwave Communications's Guest(s) fail to vacate the Remote Collocation Space within thirty (30) calendar days from the Termination Date, BellSouth shall have the right to remove the equipment and dispose of the equipment and other property of Clearwave Communications or Clearwave Communications's

Guest(s), in any manner that BellSouth deems fit, at Clearwave Communications's expense and with no liability whatsoever for Clearwave Communications's or Clearwave Communications's Guest(s)'s property. Upon termination of Clearwave Communications's right to occupy Remote Collocation Space, the Remote Collocation Space will revert back to BellSouth, and Clearwave Communications shall surrender such Remote Collocation Space to BellSouth in the same condition as when first occupied by the Clearwave Communications except for ordinary wear and tear unless otherwise agreed to by the Parties. For CEVs and huts Clearwave Communications's BellSouth Certified Supplier shall be responsible for updating and making any necessary changes to BellSouth's records as required by BellSouth's Specifications including but not limited to Record Drawings and ERMA Records. Clearwave Communications shall be responsible for the cost of removing any Clearwave Communications constructed enclosure, together with all support structures (e.g., racking, conduits, or power cables), at the termination of occupancy and restoring the grounds to their original condition.

## **5. Use of Remote Collocation Space**

- 5.1 **Equipment Type.** BellSouth permits the collocation of any type of equipment necessary for interconnection to BellSouth's network or for access to BellSouth's unbundled network elements in the provision of telecommunications services, as the term "necessary" is defined by FCC 47 C.F.R. Section 51.323 (b). The primary purpose and function of any equipment collocated in a Remote Collocation Space must be for interconnection to BellSouth's network or for access to BellSouth's unbundled network elements in the provision of telecommunications services.
- 5.1.1 Examples of equipment that would not be considered necessary include but are not limited to: traditional circuit switching equipment, equipment used exclusively for call-related databases, computer servers used exclusively for providing information services, operations support system (OSS) equipment used to support collocated telecommunications carrier network operations, equipment that generates customer orders, manages trouble tickets or inventory, or stores customer records in centralized databases, etc. BellSouth will determine upon receipt of an application if the requested equipment is necessary based on the criteria established by the FCC. Multifunctional equipment placed on BellSouth's Premises must not place any greater relative burden on BellSouth's property than comparable single-function equipment. BellSouth reserves the right to permit collocation of any equipment on a nondiscriminatory basis.
- 5.1.2 Such equipment must, at a minimum, meet the following Telcordia Network Equipment Building Systems (NEBS) General Equipment Requirements: Criteria Level 3 requirements as outlined in the Telcordia Special Report SR-3580, Issue 1. Except where otherwise required by a Commission, BellSouth shall comply with the applicable FCC rules relating to denial of collocation based on Clearwave Communications's failure to comply with this Section.

- 5.1.2.1 All Clearwave Communications equipment installation shall comply with BellSouth TR 73503-11h, "Grounding - Engineering Procedures". Metallic cable sheaths and metallic strength members of optical fiber cables as well as the metallic cable sheaths of all copper conductor cables shall be bonded to the designated grounding bus for the Remote Site Location. All copper conductor pairs, working and non-working, shall be equipped with a solid-state protector unit (over-voltage protection only), which has been listed by a nationally recognized testing laboratory.
- 5.1.3 Clearwave Communications shall identify to BellSouth whenever Clearwave Communications submits a Method of Procedure ("MOP") adding equipment to Clearwave Communications's Remote Collocation Space all UCC-1 lien holders or other entities that have a financial interest, secured or otherwise, in the equipment in Clearwave Communications's Remote Collocation Space. Clearwave Communications shall submit a copy of the list of any lien holders or other entities that have a financial interest to Clearwave Communications's ATCC Representative.
- 5.2 Clearwave Communications shall not use the Remote Collocation Space for marketing purposes nor shall it place any identifying signs or markings in the area surrounding the Remote Collocation Space or on the grounds of the Remote Site Location.
- 5.3 Clearwave Communications shall place a plaque or other identification affixed to Clearwave Communications's equipment to identify Clearwave Communications's equipment, including a list of emergency contacts with telephone numbers.
- 5.4 Entrance Facilities. Clearwave Communications may elect to place Clearwave Communications-owned or Clearwave Communications-leased fiber entrance facilities into the Remote Collocation Space. BellSouth will designate the point of interconnection at the Remote Site Location housing the Remote Collocation Space, which is physically accessible by both Parties. Clearwave Communications will provide and place copper cable through conduit from the Remote Collocation Space to the Feeder Distribution Interface to the splice location of sufficient length for splicing by BellSouth. Clearwave Communications must contact BellSouth for instructions prior to placing the entrance facility cable. Clearwave Communications is responsible for maintenance of the entrance facilities.
- 5.4.1 Shared Use. Clearwave Communications may utilize spare capacity on an existing interconnector entrance facility for the purpose of providing an entrance facility to Clearwave Communications's collocation arrangement within the same BellSouth Remote Site Location. BellSouth shall allow splicing to the entrance facility, provided that the fiber is non-working fiber. Clearwave Communications must arrange with BellSouth in accordance with BellSouth's Special Construction Procedures, RL93-11-030BT, and provide a LOA from the other telecommunications carrier for BellSouth to splice the Clearwave Communications provided riser cable to the spare capacity on the entrance facility. If Clearwave Communications desires to allow another telecommunications carrier to use its entrance facilities, then that telecommunications

- carrier must arrange with BellSouth in accordance with BellSouth's Special Construction Procedures, RL93-11-030BT, and provide a LOA from Clearwave Communications for BellSouth to splice that telecommunications carrier's provided riser cable to the spare capacity on Clearwave Communications's entrance facility.
- 5.5 Demarcation Point. BellSouth will designate the point(s) of demarcation between Clearwave Communications's equipment and/or network and BellSouth's network. Each Party will be responsible for maintenance and operation of all equipment/facilities on its side of the demarcation point. Clearwave Communications or its agent must perform all required maintenance to Clearwave Communications equipment/facilities on its side of the demarcation point, pursuant to Section 5.6, following.
- 5.6 Clearwave Communications's Equipment and Facilities. Clearwave Communications, or if required by this Attachment, Clearwave Communications's BellSouth Certified Supplier, is solely responsible for the design, engineering, installation, testing, provisioning, performance, monitoring, maintenance and repair of the equipment and facilities used by Clearwave Communications which must be performed in compliance with all applicable BellSouth Specifications. Such equipment and facilities may include but are not limited to cable(s), equipment, and point of termination connections. Clearwave Communications and its selected BellSouth Certified Supplier must follow and comply with all BellSouth requirements outlined in BellSouth's TR 73503, TR 73519, TR 73572, and TR 73564.
- 5.7 BellSouth's Access to Remote Collocation Space. From time to time BellSouth may require access to the Remote Collocation Space. BellSouth retains the right to access the Remote Collocation Space for the purpose of making BellSouth equipment and Remote Site Location modifications. Except in case of emergency, BellSouth will give notice to Clearwave Communications at least forty-eight (48) hours before access to the Remote Collocation Space is required. Clearwave Communications may elect to be present whenever BellSouth performs work in the Collocation Space. The Parties agree that Clearwave Communications will not bear any of the expense associated with this work.
- 5.8 Access. Pursuant to Section 12, Clearwave Communications shall have access to the Remote Collocation Space twenty-four (24) hours a day, seven (7) days a week. Clearwave Communications agrees to provide the name and social security number or date of birth or driver's license number of each employee, supplier, or agents of Clearwave Communications or Clearwave Communications's Guests to be provided with access keys or cards ("Access Keys") prior to the issuance of said Access Keys using form RF-2906-C "CLEC and CLEC Certified Supplier Access Request and Acknowledgement". Key acknowledgement forms, "Collocation Acknowledgement Sheet" for access cards and "Key Acknowledgement Form" for keys, must be signed by Clearwave Communications and returned to BellSouth Access Management within fifteen (15) calendar days of Clearwave Communications's receipt. Failure to return properly acknowledged forms will result in the holding of subsequent requests until

- acknowledgements are current. Access Keys shall not be duplicated under any circumstances. Clearwave Communications agrees to be responsible for all Access Keys and for the return of all said Access Keys in the possession of Clearwave Communications's employees, suppliers, Guests, or agents after termination of the employment relationship, contractual obligation with Clearwave Communications or upon the termination of this Attachment or the termination of occupancy of an individual Remote Collocation Space arrangement.
- 5.8.1 BellSouth will permit one accompanied site visit to Clearwave Communications's designated collocation arrangement location after receipt of the BFFO without charge to Clearwave Communications. Clearwave Communications must submit to BellSouth the completed Access Control Request Form for all employees or agents requiring access to the BellSouth Remote Site Location a minimum of thirty (30) calendar days prior to the date Clearwave Communications desires access to the Remote Collocation Space. In order to permit reasonable access during construction of the Remote Collocation Space, Clearwave Communications may submit such a request at any time subsequent to BellSouth's receipt of the BFFO. In the event Clearwave Communications desires access to the Remote Collocation Space after submitting such a request but prior to access being approved, in addition to the first accompanied free visit, BellSouth shall permit Clearwave Communications to access the Remote Collocation Space accompanied by a security escort at Clearwave Communications's expense. Clearwave Communications must request escorted access at least three (3) business days prior to the date such access is desired.
- 5.9 Lost or Stolen Access Keys. Clearwave Communications shall notify BellSouth in writing immediately in the case of lost or stolen Access Keys. Should it become necessary for BellSouth to re-key Remote Site Locations or deactivate a card as a result of a lost Access Key(s) or for failure to return an Access Key(s), Clearwave Communications shall pay for all reasonable costs associated with the re-keying or deactivating the card.
- 5.10 Interference or Impairment. Notwithstanding any other provisions of this Attachment, Clearwave Communications shall not use any product or service provided under this Agreement, any other service related thereto or used in combination therewith, or place or use any equipment and facilities in any manner that 1) significantly degrades, interferes with or impairs service provided by BellSouth or by any other entity or any person's use of its telecommunications service; 2) endangers or damages the equipment, facilities or other property of BellSouth or of any other entity or person; 3) compromises the privacy of any communications; or 4) creates an unreasonable risk of injury or death to any individual or to the public. If BellSouth reasonably determines that any equipment or facilities of Clearwave Communications violates the provisions of this paragraph, BellSouth shall give written notice to Clearwave Communications, which notice shall direct Clearwave Communications to cure the violation within forty-eight (48) hours of Clearwave Communications's actual receipt of written notice or, at a minimum, to commence curative measures within 24 hours and to exercise

- reasonable diligence to complete such measures as soon as possible thereafter. After receipt of the notice, the Parties agree to consult immediately and, if necessary, to inspect the arrangement.
- 5.10.1 Except in the case of the deployment of an advanced service which significantly degrades the performance of other advanced services or traditional voice band services, if Clearwave Communications fails to take curative action within forty-eight (48) hours or if the violation is of a character which poses an immediate and substantial threat of damage to property, injury or death to any person, or any other significant degradation, interference or impairment of BellSouth's or any other entity's service, then and only in that event BellSouth may take such action as it deems appropriate to correct the violation, including without limitation the interruption of electrical power to Clearwave Communications's equipment. BellSouth will endeavor, but is not required, to provide notice to Clearwave Communications prior to taking such action and shall have no liability to Clearwave Communications for any damages arising from such action, except to the extent that such action by BellSouth constitutes willful misconduct.
- 5.10.2 For purposes of this section, the term significantly degrade shall mean an action that noticeably impairs a service from a user's perspective. In the case of the deployment of an advanced service which significantly degrades the performance of other advanced services or traditional voice band services and Clearwave Communications fails to take curative action within forty-eight (48) hours then BellSouth will establish before the Commission that the technology deployment is causing the significant degradation. Any claims of network harm presented to Clearwave Communications or, if subsequently necessary, the Commission must be supported with specific and verifiable information. Where BellSouth demonstrates that a deployed technology is significantly degrading the performance of other advanced services or traditional voice band services, Clearwave Communications shall discontinue deployment of that technology and migrate its customers to technologies that will not significantly degrade the performance of other such services. Where the only degraded service itself is a known disturber, and the newly deployed technology satisfies at least one of the criteria for a presumption that is acceptable for deployment under Section 47 C.F.R. 51.230, the degraded service shall not prevail against the newly-deployed technology.
- 5.11 Personalty and its Removal. Facilities and equipment placed by Clearwave Communications in the Remote Collocation Space shall not become a part of the Remote Site Location, even if nailed, screwed or otherwise fastened to the Remote Collocation Space but shall retain their status as personalty and may be removed by Clearwave Communications at any time. Any damage caused to the Remote Collocation Space by Clearwave Communications's employees, agents or representatives shall be promptly repaired by Clearwave Communications at its expense.

- 5.11.1 If Clearwave Communications decides to remove equipment from its Remote Collocation Space and the removal requires no physical changes, BellSouth will bill Clearwave Communications an Administrative Only Application Fee as set forth in Exhibit B for these changes. This nonrecurring fee will be billed on the date that BellSouth provides an Application Response.
- 5.12 Alterations. In no case shall Clearwave Communications or any person acting on behalf of Clearwave Communications make any rearrangement, modification, improvement, addition, or other alteration which could affect in any way space, power, HVAC, and/or safety considerations to the Remote Collocation Space or the BellSouth Remote Site Location without the written consent of BellSouth, which consent shall not be unreasonably withheld. The cost of any specialized alterations shall be paid by Clearwave Communications. Any such material rearrangement, modification, improvement, addition, or other alteration shall require an application and Application Fee. BellSouth will bill the nonrecurring fee on the date that BellSouth provides an Application Response.
- 5.13 Upkeep of Remote Collocation Space. Clearwave Communications shall be responsible for the general upkeep and cleaning of the Remote Collocation Space. Clearwave Communications shall be responsible for removing any Clearwave Communications debris from the Remote Collocation Space and from in and around the Remote Site Location on each visit.
- 6. Ordering and Preparation of Remote Collocation Space**
- 6.1 Should any state or federal regulatory agency impose procedures or intervals applicable to Clearwave Communications and BellSouth that are different from procedures or intervals set forth in this Section, whether now in effect or that become effective after execution of this Agreement, those procedures or intervals shall supersede the requirements set forth herein for that jurisdiction for all applications submitted for the first time after the effective date thereof
- 6.2 Remote Site Application. When Clearwave Communications or Clearwave Communications's Guest(s) desires to install a bay/rack in a Remote Site Location, Clearwave Communications shall submit to BellSouth a Physical Expanded Interconnection Application Document ("Application"). The application is Bona Fide when it is complete and accurate, meaning that all required fields on the application are completed with the appropriate type of information. An application fee will apply which will be billed on the date that BellSouth provides an Application Response. The placement of an additional bay/rack at a later date will be treated in the same fashion and an application will be required. The installation of additional shelves/equipment, subject to the restrictions contained in Section 5.10, within an existing bay/rack does not require an application.
- 6.3 Availability of Space. Upon submission of an application, BellSouth will permit Clearwave Communications to physically collocate, pursuant to the terms of this

Attachment, at any BellSouth Remote Site Location, unless BellSouth has determined that there is no space available due to space limitations or that collocation at the Remote Site Location is not practical for technical reasons. In the event space is not immediately available at a Remote Site Location, BellSouth reserves the right to make additional space available, in which case the conditions in Section 7 shall apply, or BellSouth may elect to deny space in accordance with this Section in which case virtual or adjacent collocation options may be available. If the amount of space requested is not available, BellSouth will notify Clearwave Communications of the amount that is available.

#### 6.4 Space Availability Notification.

6.4.1 Unless otherwise specified, BellSouth will respond to an application within ten (10) calendar days as to whether space is available or not available within a BellSouth Remote Site Location. BellSouth will also respond as to whether the application is Bona Fide and if it is not Bona Fide the items necessary to cause the application to become Bona Fide. If the amount of space requested is not available, BellSouth will notify Clearwave Communications of the amount of space that is available and no Application Fee shall apply. When BellSouth's response includes an amount of space less than that requested by Clearwave Communications or differently configured no application fee shall apply. If Clearwave Communications decides to accept the available space, Clearwave Communications must resubmit its application to reflect the actual space available prior to submitting a BFFO and an application fee will be billed.

6.4.2 BellSouth will respond to a Florida application within fifteen (15) calendar days as to whether space is available or not available within a BellSouth Remote Site Location. BellSouth will also respond as to whether the application is Bona Fide and if it is not Bona Fide the items necessary to cause the application to become Bona Fide. If a lesser amount of space than requested is available, BellSouth will provide an Application Response for the amount of space that is available and an Application Fee will be billed by BellSouth on the date that BellSouth provides an Application Response. When BellSouth's Application Response includes an amount of space less than that requested by Clearwave Communications or differently configured, if Clearwave Communications decides to accept the available space, Clearwave Communications must amend its application to reflect the actual space available prior to submitting a BFFO.

6.4.3 BellSouth will respond to a Louisiana application within ten (10) calendar days for space availability for one (1) to ten (10) applications; fifteen (15) calendar days for eleven (11) to twenty (20) applications; and for more than twenty (20) applications, the response interval is increased by five (5) calendar days for every five additional applications received within five (5) business days. If the amount of space requested is not available, BellSouth will notify Clearwave Communications of the amount of space that is available and no Application Fee will apply. When BellSouth's response includes an amount of space less than that requested by Clearwave Communications or



- differently configured no application fee shall apply. If Clearwave Communications decides to accept the available space, Clearwave Communications must resubmit its application to reflect the actual space available prior to submitting a BFFO and an application fee will be billed. BellSouth will also respond as to whether the application is Bona Fide and if it is not Bona Fide the items necessary to cause the application to become Bona Fide.
- 6.5 Denial of Application. If BellSouth notifies Clearwave Communications that no space is available (“Denial of Application”), BellSouth will not assess an Application Fee. After notifying Clearwave Communications that BellSouth has no available space in the requested Remote Site Location, BellSouth will allow Clearwave Communications, upon request, to tour the Remote Site Location within ten (10) calendar days of such Denial of Application. In order to schedule said tour within ten (10) calendar days, the request for a tour of the Remote Site Location must be received by BellSouth within five (5) calendar days of the Denial of Application.
- 6.6 Filing of Petition for Waiver. Upon Denial of Application BellSouth will timely file a petition with the Commission pursuant to 47 U.S.C. § 251(c)(6). BellSouth shall provide to the Commission any information requested by that Commission. Such information shall include which space, if any, BellSouth or any of BellSouth’s affiliates have reserved for future use and a detailed description of the specific future uses for which the space has been reserved. Subject to an appropriate nondisclosure agreement or provision, BellSouth shall permit Clearwave Communications to inspect any plans or diagrams that BellSouth provides to the Commission.
- 6.7 Waiting List. On a first-come, first-served basis governed by the date of receipt of an application or Letter of Intent, BellSouth will maintain a waiting list of requesting carriers who have either received a Denial of Application or, where it is publicly known that the Remote Site Location is out of space, have submitted a Letter of Intent to collocate. BellSouth will notify the telecommunications carriers on the waiting list that can be accommodated by the amount of space that becomes available according to the position of the telecommunications carriers on said waiting list.
- 6.7.1 In Florida, on a first-come, first-served basis governed by the date of receipt of an application or Letter of Intent, BellSouth will maintain a waiting list of requesting carriers who have either received a Denial of Application or, where it is publicly known that the Remote Site Location is out of space, have submitted a Letter of Intent to collocate. Sixty (60) calendar days prior to space becoming available, if known, BellSouth will notify the Florida PSC and the telecommunications carriers on the waiting list by mail when space becomes available according to the position of the telecommunications carrier on said waiting list. If not known sixty (60) calendar days in advance, BellSouth shall notify the Florida PSC and the telecommunications carriers on the waiting list within two business days of the determination that space is available. A telecommunications carrier that, upon denial of physical collocation, requests virtual collocation shall be automatically placed on the waiting list.

- 6.7.2 When space becomes available, Clearwave Communications must submit an updated, complete, and correct application to BellSouth within thirty (30) calendar days of such notification. If Clearwave Communications has originally requested caged Remote Collocation Space and cageless Remote Collocation Space becomes available, Clearwave Communications may refuse such space and notify BellSouth in writing within that time that Clearwave Communications wants to maintain its place on the waiting list without accepting such space. Clearwave Communications may accept an amount of space less than its original request by submitting an application as set forth above, and upon request, may maintain its position on the waiting list for the remaining space that was initially requested. If Clearwave Communications does not submit such an application or notify BellSouth in writing as described above, BellSouth will offer such space to the next telecommunications carrier on the waiting list and remove Clearwave Communications from the waiting list. Upon request, BellSouth will advise Clearwave Communications as to its position on the list.
- 6.8 Public Notification. BellSouth will maintain on its Interconnection Services website a notification document that will indicate all Remote Site Locations that are without available space. BellSouth shall update such document within ten (10) calendar days of the date that BellSouth becomes aware that there is insufficient space to accommodate collocation at the Remote Site Location. BellSouth will also post a document on its Interconnection Services website that contains a general notice where space has become available in a Remote Site Location previously on the space exhaust list.
- 6.9 Application Response.
- 6.9.1 In Florida, within fifteen (15) calendar days of receipt of a Bona Fide application, when space has been determined to be available or when a lesser amount of space than that requested is available, then with respect to the space available, BellSouth will provide an Application Response including sufficient information to enable Clearwave Communications to place a Firm Order. The Application Response will include, at a minimum, the configuration of the space, the Cable Installation Fee, Cable Records Fee, and the space preparation fees, as described in Section 8. When Clearwave Communications submits ten (10) or more applications within ten (10) calendar days, the initial fifteen (15) calendar day response period will increase by ten (10) calendar days for every additional ten (10) applications or fraction thereof.
- 6.9.2 In Alabama, Georgia, Kentucky, Mississippi, North Carolina, South Carolina, and Tennessee when space has been determined to be available, BellSouth will provide an Application Response within twenty (20) calendar days of receipt of a Bona Fide application. The Application Response will include, at a minimum, the configuration of the space, the Cable Installation Fee, Cable Records Fee, and the space preparation fees, as described in Section 8.
- 6.9.3 In Louisiana, when space has been determined to be available, BellSouth will respond with an Application Response within thirty (30) calendar days for one (1) to ten (10)

applications; thirty (35) calendar days for eleven (11) to twenty (20) applications; and for requests of more than twenty (20) applications, the Application Response interval will be increased by five (5) calendar days for every five (5) applications received within five (5) business days. The Application Response will include, at a minimum, the configuration of the space, the Cable Installation Fee, Cable Records Fee, and the space preparation fees, as described in Section 8.

6.10 Application Modifications.

6.10.1 If a modification or revision is made to any information in the Bona Fide application prior to a BFFO, with the exception of modifications to Customer Information, Contact Information or Billing Contact Information, either at the request of Clearwave Communications or necessitated by technical considerations, said application shall be considered a new application and shall be handled as a new application with respect to response and provisioning intervals and BellSouth will charge Clearwave Communications a full application fee as set forth in Exhibit B. BellSouth will bill the nonrecurring fee on the date that BellSouth provides an Application Response.

6.10.2 Bona Fide Firm Order.

6.10.3 Clearwave Communications shall indicate its intent to proceed with equipment installation in a BellSouth Remote Site Location by submitting a Firm Order to BellSouth. The BFFO must be received by BellSouth no later than thirty (30) calendar days after BellSouth's Application Response to Clearwave Communications's Bona Fide application or the application will expire.

6.10.4 BellSouth will establish a firm order date based upon the date BellSouth is in receipt of a BFFO. BellSouth will acknowledge the receipt of Clearwave Communications's BFFO within seven (7) calendar days of receipt indicating that the BFFO has been received. A BellSouth response to a BFFO will include a Firm Order Confirmation containing the firm order date. No revisions will be made to a BFFO.

**7. Construction and Provisioning**

7.1 Construction and Provisioning Intervals.

7.1.1 In Florida, BellSouth will complete construction for collocation arrangements as soon as possible and within a maximum of ninety (90) calendar days from receipt of a BFFO or as agreed to by the Parties. For changes to Remote Collocation Space after initial space completion ("Augmentation"), BellSouth will complete construction for collocation arrangements as soon as possible and within a maximum of forty-five (45) calendar days from receipt of a BFFO or as agreed to by the Parties. If BellSouth does not believe that construction will be completed within the relevant time frame and BellSouth and Clearwave Communications cannot agree upon a completion date, within forty-five (45) calendar days of receipt of the BFFO for an initial request, and

- within thirty (30) calendar days for Augmentations, BellSouth may seek an extension from the Florida Commission.
- 7.1.2 In Alabama, Georgia, Kentucky, Mississippi, North Carolina, South Carolina, and Tennessee, BellSouth will complete construction for collocation arrangements under ordinary conditions as soon as possible and within a maximum of sixty (60) calendar days from receipt of a BFFO and ninety (90) calendar days from receipt of a BFFO for extraordinary conditions or as agreed to by the Parties. Ordinary conditions are defined as space available with only minor changes to support systems required, such as but not limited to, HVAC, cabling and the power plant(s). Extraordinary conditions shall include, but not limited to, major BellSouth equipment rearrangement or addition; power plant addition or upgrade; major mechanical addition or upgrade; major upgrade for ADA compliance; environmental hazard or hazardous materials abatement; and arrangements for which equipment shipping intervals are extraordinary in length. The Parties may mutually agree to renegotiate an alternative provisioning interval or BellSouth may seek a waiver from this interval from the Commission.
- 7.1.3 In Louisiana, BellSouth will complete construction for collocation arrangements under ordinary conditions as soon as possible and within a maximum of sixty (60) calendar days from receipt of a BFFO for an initial request, and within 60 calendar days for an Augmentation, or as agreed to by the Parties. The Parties may mutually agree to renegotiate an alternative provisioning interval or BellSouth may seek a waiver from this interval from the Commission.
- 7.2 In the event BellSouth does not have space immediately available at a Remote Site Location, BellSouth may elect to make additional space available by, for example but not limited to, rearranging BellSouth facilities or constructing additional capacity. In such cases, the above intervals shall not apply and BellSouth will provision the Remote Collocation Space in a nondiscriminatory manner and at parity with BellSouth and will provide Clearwave Communications with the estimated completion date in its Response.
- 7.3 Joint Planning. Joint planning between BellSouth and Clearwave Communications will commence within a maximum of twenty (20) calendar days from BellSouth's receipt of a BFFO. BellSouth will provide the preliminary design of the Remote Collocation Space and the equipment configuration requirements as reflected in the Bona Fide application and affirmed in the BFFO. The Remote Collocation Space completion time period will be provided to Clearwave Communications during joint planning.
- 7.4 Permits. Each Party or its agents will diligently pursue filing for the permits required for the scope of work to be performed by that Party or its agents within ten (10) calendar days of the completion of finalized construction designs and specifications.
- 7.5 Acceptance Walkthrough. Clearwave Communications will schedule and complete an acceptance walkthrough of each Remote Collocation Space with BellSouth within

- fifteen (15) calendar days of BellSouth's notifying Clearwave Communications that the Remote Collocation Space is ready for occupancy. In the event that Clearwave Communications fails to complete an acceptance walkthrough within this fifteen (15) calendar day interval, the Remote Collocation Space shall be deemed accepted by Clearwave Communications on the Space Ready Date. BellSouth will correct any deviations to Clearwave Communications's original or jointly amended requirements within seven (7) calendar days after the walkthrough, unless the Parties jointly agree upon a different time frame.
- 7.6 Use of BellSouth Certified Supplier. Clearwave Communications shall select a supplier which has been approved by BellSouth to perform all engineering and installation work. Clearwave Communications and Clearwave Communications's BellSouth Certified Supplier must follow and comply with all BellSouth requirements outlined in BellSouth's TR 73503, TR 73519, TR 73572, and TR 73564. In some cases, Clearwave Communications must select separate BellSouth Certified Suppliers for transmission equipment, switching equipment and power equipment. BellSouth shall provide Clearwave Communications with a list of BellSouth Certified Suppliers upon request. The BellSouth Certified Supplier(s) shall be responsible for installing Clearwave Communications's equipment and components, extending power cabling to the BellSouth power distribution frame, performing operational tests after installation is complete, and notifying BellSouth's Outside Plant engineers and Clearwave Communications upon successful completion of installation. The BellSouth Certified Supplier shall bill Clearwave Communications directly for all work performed for Clearwave Communications pursuant to this Attachment, and BellSouth shall have no liability for nor responsibility to pay such charges imposed by the BellSouth Certified Supplier. BellSouth shall make available its supplier certification program to Clearwave Communications or any supplier proposed by Clearwave Communications and will not unreasonably withhold certification. All work performed by or for Clearwave Communications shall conform to generally accepted industry standards.
- 7.7 Alarm and Monitoring. BellSouth may place alarms in the Remote Site Location for the protection of BellSouth equipment and facilities. Clearwave Communications shall be responsible for placement, monitoring and removal of environmental and equipment alarms used to service Clearwave Communications's Remote Collocation Space. Upon request, BellSouth will provide Clearwave Communications with applicable tariffed service(s) to facilitate remote monitoring of collocated equipment by Clearwave Communications. Both Parties shall use best efforts to notify the other of any verified hazardous conditions known to that Party.
- 7.8 Virtual Remote Collocation Space Relocation. In the event physical Remote Collocation Space was previously denied at a Remote Site Location due to technical reasons or space limitations, and physical Remote Collocation Space has subsequently become available, Clearwave Communications may relocate its virtual Remote Collocation arrangements to physical Remote Collocation Space arrangements and pay the appropriate fees for physical Remote Collocation Space and for the rearrangement

- or reconfiguration of services terminated in the virtual Remote Collocation Space arrangement, as outlined in the appropriate BellSouth tariffs. In the event that BellSouth knows when additional space for physical Remote Collocation Space may become available at the location requested by Clearwave Communications, such information will be provided to Clearwave Communications in BellSouth's written denial of physical Remote Collocation Space. To the extent that (i) physical Remote Collocation Space becomes available to Clearwave Communications within one hundred eighty (180) calendar days of BellSouth's written denial of Clearwave Communications's request for physical collocation, (ii) BellSouth had knowledge that the space was going to become available, and (iii) Clearwave Communications was not informed in the written denial that physical Remote Collocation Space would become available within such one hundred eighty (180) calendar days, then Clearwave Communications may relocate its virtual Remote Collocation Space arrangement to a physical Remote Collocation Space arrangement and will receive a credit for any nonrecurring charges previously paid for such virtual Remote Collocation Space. Clearwave Communications must arrange with a BellSouth Certified Supplier for the relocation of equipment from its virtual Remote Collocation Space to its physical Remote Collocation Space and will bear the cost of such relocation.
- 7.8.1 In Alabama, BellSouth will complete a relocation from virtual collocation to physical collocation within ninety (90) calendar days.
- 7.9 Virtual to Physical Conversion (In-Place). Virtual collocation arrangements may be converted to "in-place" physical arrangements if the potential conversion meets the following four criteria: 1) there is no change in the amount of equipment or the configuration of the equipment that was in the virtual collocation arrangement; 2) the conversion of the virtual collocation arrangement will not cause the equipment or the results of that conversion to be located in a space that BellSouth has reserved for its own future needs; 3) the converted arrangement does not limit BellSouth's ability to secure its own equipment and facilities due to the location of the virtual collocation arrangement; and 4) any changes to the arrangement can be accommodated by existing power, HVAC, and other requirements. Unless otherwise specified, BellSouth will complete virtual to in-place physical collocation conversions within sixty (60) calendar days from receipt of the BFFO. BellSouth will bill Clearwave Communications an Administrative Only Application Fee as set forth in Exhibit B for these charges on the date that BellSouth provides an Application Response.
- 7.9.1 In Alabama and Tennessee, BellSouth will complete Virtual to Physical Conversions (In Place) within thirty (30) calendar days from receipt of the BFFO.
- 7.10 Cancellation. If, at any time prior to space acceptance, Clearwave Communications cancels its order for the Remote Collocation Space(s) ("Cancellation"), BellSouth will bill the applicable nonrecurring rate for any and all work processes for which work has begun. In Georgia, if Clearwave Communications cancels its order for Remote Collocation Space at any time prior to space acceptance, BellSouth will bill Clearwave

Communications for all costs incurred prior to the date of Cancellation and for any costs incurred as a direct result of the Cancellation, not to exceed the total amount that would have been due had the order not been cancelled.

- 7.11 Licenses. Clearwave Communications, at its own expense, will be solely responsible for obtaining from governmental authorities, and any other appropriate agency, entity, or person, all rights, privileges, and licenses necessary or required to operate as a provider of telecommunications services to the public or to build-out, equip and occupy the Remote Collocation Space.
- 7.12 Environmental Hazard Guidelines. The Parties agree to utilize and adhere to the Environmental Hazard Guidelines identified in Exhibit A attached hereto.

## **8. Rates and Charges**

- 8.1 Recurring Charges. If Clearwave Communications has met the applicable fifteen (15) calendar day walkthrough interval(s) specified in Section 4, billing for recurring charges will begin upon the Space Acceptance Date. In the event that Clearwave Communications fails to complete an acceptance walkthrough within the applicable fifteen (15) calendar day interval(s), billing for recurring charges will commence on the Space Ready Date. If Clearwave Communications occupies the space prior to the Space Ready Date, the date Clearwave Communications occupies the space becomes the new Space Acceptance Date and billing for recurring charges begin on that date.
- 8.2 Application Fee. BellSouth shall assess an Application Fee via a service order, which shall be issued at the time BellSouth responds that space is available pursuant to Section 6.10 (Application Response). This nonrecurring fee will be billed by BellSouth on the date that BellSouth provides an Application Response.
- 8.2.1 In Tennessee, the applicable application fee is the planning fee for both Initial Applications and Subsequent Applications placed by Clearwave Communications. This nonrecurring fee will be billed by BellSouth on the date that BellSouth provides an Application Response.
- 8.3 Rack/Bay Space. The rack/bay space charge includes reasonable charges for air conditioning, ventilation and other allocated expenses associated with maintenance of the Remote Site Location, and includes amperage necessary to power Clearwave Communications's equipment. Clearwave Communications shall pay rack/bay space charges based upon the number of racks/bays requested. BellSouth will assign Remote Collocation Space in conventional remote site rack/bay lineups where feasible.
- 8.4 Power. BellSouth shall make available -48 Volt (-48V) DC power for Clearwave Communications's Remote Collocation Space at a BellSouth Power Board or BellSouth Battery Distribution Fuse Bay (BDFB) at Clearwave Communications's option within the Remote Site Location. The charge for power shall be assessed as part of the recurring charge for rack/bay space. If the power requirements for

- Clearwave Communications's equipment exceeds the capacity available, then such power requirements shall be assessed on an individual case basis. BellSouth will revise recurring power charges to reflect a power upgrade upon notification of the completion of the upgrade by Clearwave Communications's BellSouth Certified Vendor. BellSouth will revise recurring power charges to reflect a power reduction upon BellSouth's receipt of the Power Reduction Form from Clearwave Communications certifying the completion of the power reduction, including the removal of the power cabling by Clearwave Communications's BellSouth Certified Supplier.
- 8.4.1 Adjacent Collocation Power. Charges for AC power will be assessed per breaker ampere per month. Rates include the provision of commercial and standby AC power, where available. When obtaining power from a BellSouth service panel, protection devices and power cables must be engineered (sized), and installed by Clearwave Communications's BellSouth Certified Supplier except that BellSouth shall engineer and install protection devices and power cables for Adjacent Collocation. Clearwave Communications's BellSouth Certified Supplier must also provide a copy of the engineering power specification prior to the equipment becoming operational. Charges for AC power shall be assessed pursuant to the rates specified in Exhibit B. AC power voltage and phase ratings shall be determined on a per location basis. At Clearwave Communications's option, Clearwave Communications may arrange for AC power in an Adjacent Collocation arrangement from a retail provider of electrical power.
- 8.5 Security Escort. A security escort will be required whenever Clearwave Communications or its approved agent desires access to the Remote Site Location after the one accompanied site visit allowed pursuant to Section 5 prior to completing BellSouth's Security Training requirements. Rates for a security escort are assessed according to the schedule appended hereto as Exhibit B beginning with the scheduled escort time. BellSouth will wait for one-half (1/2) hour after the scheduled time for such an escort and Clearwave Communications shall pay for such half-hour charges in the event Clearwave Communications fails to show up.
- 8.6 Other. If no rate is identified in the contract, the rate for the specific service or function will be negotiated by the Parties upon request by either Party.
- 9. Insurance**
- 9.1 Clearwave Communications shall, at its sole cost and expense, procure, maintain, and keep in force insurance as specified in this Section and underwritten by insurance companies licensed to do business in the states applicable under this Agreement and having a Best's Insurance Rating of A-.
- 9.2 Clearwave Communications shall maintain the following specific coverage:



- 9.2.1 Commercial General Liability coverage in the amount of ten million dollars (\$10,000,000.00) or a combination of Commercial General Liability and Excess/Umbrella coverage totaling not less than ten million dollars (\$10,000,000.00). BellSouth shall be named as an Additional Insured on the Commercial General Liability policy as specified herein.
- 9.2.2 Statutory Workers Compensation coverage and Employers Liability coverage in the amount of one hundred thousand dollars (\$100,000.00) each accident, one hundred thousand dollars (\$100,000.00) each employee by disease, and five hundred thousand dollars (\$500,000.00) policy limit by disease.
- 9.2.3 All Risk Property coverage on a full replacement cost basis insuring all of Clearwave Communications's real and personal property situated on or within BellSouth's Remote Site Location.
- 9.2.4 Clearwave Communications may elect to purchase business interruption and contingent business interruption insurance, having been advised that BellSouth assumes no liability for loss of profit or revenues should an interruption of service occur.
- 9.3 The limits set forth in Section 9.2 above may be increased by BellSouth from time to time during the term of this Agreement upon thirty (30) calendar days notice to Clearwave Communications to at least such minimum limits as shall then be customary with respect to comparable occupancy of BellSouth structures.
- 9.4 All policies purchased by Clearwave Communications shall be deemed to be primary and not contributing to or in excess of any similar coverage purchased by BellSouth. All insurance must be in effect on or before the date equipment is delivered to BellSouth's Remote Site Location and shall remain in effect for the term of this Attachment or until all of Clearwave Communications's property has been removed from BellSouth's Remote Site Location, whichever period is longer. If Clearwave Communications fails to maintain required coverage, BellSouth may pay the premiums thereon and seek reimbursement of same from Clearwave Communications.
- 9.5 Clearwave Communications shall submit certificates of insurance reflecting the coverage required pursuant to this Section a minimum of ten (10) business days prior to the commencement of any work in the Remote Collocation Space. Failure to meet this interval may result in construction and equipment installation delays. Clearwave Communications shall arrange for BellSouth to receive thirty (30) business days' advance notice of cancellation from Clearwave Communications's insurance company. Clearwave Communications shall forward a certificate of insurance and notice of cancellation/non-renewal to BellSouth at the following address:

BellSouth Telecommunications, Inc.  
Attn.: Risk Management Coordinator

17H53 BellSouth Center  
675 W. Peachtree Street  
Atlanta, Georgia 30375

- 9.6 Clearwave Communications must conform to recommendations made by BellSouth's fire insurance company to the extent BellSouth has agreed to, or shall hereafter agree to, such recommendations.
- 9.7 Self-Insurance. If Clearwave Communications's net worth exceeds five hundred million dollars (\$500,000,000), Clearwave Communications may elect to request self-insurance status in lieu of obtaining any of the insurance required in Sections 9.2.1 and 9.2.2. Clearwave Communications shall provide audited financial statements to BellSouth thirty (30) calendar days prior to the commencement of any work in the Remote Collocation Space. BellSouth shall then review such audited financial statements and respond in writing to Clearwave Communications in the event that self-insurance status is not granted to Clearwave Communications. If BellSouth approves Clearwave Communications for self-insurance, Clearwave Communications shall annually furnish to BellSouth, and keep current, evidence of such net worth that is attested to by one of Clearwave Communications's corporate officers. The ability to self-insure shall continue so long as Clearwave Communications meets all of the requirements of this Section. If Clearwave Communications subsequently no longer satisfies this Section, Clearwave Communications is required to purchase insurance as indicated by Sections 9.2.1 and Section 9.2.2.
- 9.8 The net worth requirements set forth in Section 9.7 may be increased by BellSouth from time to time during the term of this Attachment upon thirty (30) calendar days' notice to Clearwave Communications to at least such minimum limits as shall then be customary with respect to comparable occupancy of BellSouth structures.
- 9.9 Failure to comply with the provisions of this Section will be deemed a material breach of this Attachment.
- 10. Mechanics Liens**
- 10.1 If any mechanics lien or other liens shall be filed against property of either Party (BellSouth or Clearwave Communications), or any improvement thereon by reason of or arising out of any labor or materials furnished or alleged to have been furnished or to be furnished to or for the other Party or by reason of any changes, or additions to said property made at the request or under the direction of the other Party, the other Party directing or requesting those changes shall, within thirty (30) business days after receipt of written notice from the Party against whose property said lien has been filed, either pay such lien or cause the same to be bonded off the affected property in the manner provided by law. The Party causing said lien to be placed against the property of the other shall also defend, at its sole cost and expense, on behalf of the other, any action, suit or proceeding which may be brought for the enforcement of such liens and shall pay any damage and discharge any judgment entered thereon.

**11. Inspections**

11.1 BellSouth may conduct an inspection of Clearwave Communications's equipment and facilities in the Remote Collocation Space(s) prior to the activation of facilities between Clearwave Communications's equipment and equipment of BellSouth. BellSouth may conduct an inspection if Clearwave Communications adds equipment and may otherwise conduct routine inspections at reasonable intervals mutually agreed upon by the Parties. BellSouth shall provide Clearwave Communications with a minimum of forty-eight (48) hours or two (2) business days, whichever is greater, advance notice of all such inspections. All costs of such inspection shall be borne by BellSouth.

**12. Security and Safety Requirements**

12.1 Unless otherwise specified, Clearwave Communications will be required, at its own expense, to conduct a statewide investigation of criminal history records for each Clearwave Communications employee hired in the past five years being considered for work on the BellSouth Remote Site Location, for the states/counties where the Clearwave Communications employee has worked and lived for the past five years. Where state law does not permit statewide collection or reporting, an investigation of the applicable counties is acceptable. Clearwave Communications shall not be required to perform this investigation if an affiliated company of Clearwave Communications has performed an investigation of the Clearwave Communications employee seeking access, if such investigation meets the criteria set forth above. This requirement will not apply if Clearwave Communications has performed a pre-employment statewide investigation of criminal history records of the Clearwave Communications employee for the states/counties where the Clearwave Communications employee has worked and lived for the past five years or, where state law does not permit a statewide investigation, an investigation of the applicable counties.

12.2 Clearwave Communications will be required to administer to their personnel assigned to the BellSouth Premises security training either provided by BellSouth, or meeting criteria defined by BellSouth.

12.3 Clearwave Communications shall provide its employees and agents with picture identification, which must be worn, and visible at all times while in the Remote Collocation Space or other areas in or around the Remote Site Location. The photo Identification card shall bear, at a minimum, the employee's name and photo, and Clearwave Communications's name. BellSouth reserves the right to remove from its Remote Site Location any employee of Clearwave Communications not possessing identification issued by Clearwave Communications or who have violated any of BellSouth's policies as outlined in the CLEC Security Training documents. Clearwave Communications shall hold BellSouth harmless for any damages resulting from such removal of its personnel from BellSouth Remote Site Location. Clearwave Communications shall be solely responsible for ensuring that any Guest(s) of Clearwave Communications is in compliance with all subsections of this Section.

- 12.4 Clearwave Communications shall not assign to the BellSouth Remote Site Location any personnel with records of felony criminal convictions. Clearwave Communications shall not assign to the BellSouth Remote Site Location any personnel with records of misdemeanor convictions, except for misdemeanor traffic violations, without advising BellSouth of the nature and gravity of the offense(s). BellSouth reserves the right to refuse access to any Clearwave Communications personnel who have been identified to have misdemeanor criminal convictions. Notwithstanding the foregoing, in the event that Clearwave Communications chooses not to advise BellSouth of the nature and gravity of any misdemeanor conviction, Clearwave Communications may, in the alternative, certify to BellSouth that it shall not assign to the BellSouth Remote Site Location any personnel with records of misdemeanor convictions (other than misdemeanor traffic violations).
- 12.4.1 Clearwave Communications shall not knowingly assign to the BellSouth Remote Site Location any individual who was a former employee of BellSouth and whose employment with BellSouth was terminated for a criminal offense whether or not BellSouth sought prosecution of the individual for the criminal offense.
- 12.4.2 Clearwave Communications shall not knowingly assign to the BellSouth Remote Site Location any individual who was a former supplier of BellSouth and whose access to a BellSouth Remote Site Location was revoked due to commission of a criminal offense whether or not BellSouth sought prosecution of the individual for the criminal offense.
- 12.5 For each Clearwave Communications employee or agent hired by Clearwave Communications within five years of being considered for work on the BellSouth Remote Site Location, who requires access to a BellSouth Remote Site Location pursuant to this Attachment, Clearwave Communications shall furnish BellSouth, prior to an employee gaining such access, a certification that the aforementioned background check and security training were completed. The certification will contain a statement that no felony convictions were found and certifying that the security training was completed by the employee. If the employee's criminal history includes misdemeanor convictions, Clearwave Communications will disclose the nature of the convictions to BellSouth at that time. In the alternative, Clearwave Communications may certify to BellSouth that it shall not assign to the BellSouth Remote Site Location any personnel with records of misdemeanor convictions other than misdemeanor traffic violations.
- 12.5.1 For all other Clearwave Communications employees requiring access to a BellSouth Remote Site Location pursuant to this Attachment, Clearwave Communications shall furnish BellSouth, prior to an employee gaining such access, a certification that the employee is not subject to the requirements of Section 12.5 above and that security training was completed by the employee.

- 12.6 At BellSouth's request, Clearwave Communications shall promptly remove from BellSouth's Remote Site Location any employee of Clearwave Communications BellSouth does not wish to grant access to its Remote Site Location 1) pursuant to any investigation conducted by BellSouth or 2) prior to the initiation of an investigation if an employee of Clearwave Communications is found interfering with the property or personnel of BellSouth or another collocated telecommunications carrier, provided that an investigation shall promptly be commenced by BellSouth.
- 12.7 Security Violations. BellSouth reserves the right to interview Clearwave Communications's employees, agents, or suppliers in the event of wrongdoing in or around BellSouth's property or involving BellSouth's or another collocated telecommunications carrier's property or personnel, provided that BellSouth shall provide reasonable notice to Clearwave Communications's Security representative of such interview. Clearwave Communications and its suppliers shall reasonably cooperate with BellSouth's investigation into allegations of wrongdoing or criminal conduct committed by, witnessed by, or involving Clearwave Communications's employees, agents, or suppliers. Additionally, BellSouth reserves the right to bill Clearwave Communications for all reasonable costs associated with investigations involving its employees, agents, or suppliers if it is established and mutually agreed in good faith that Clearwave Communications's employees, agents, or suppliers are responsible for the alleged act. BellSouth shall bill Clearwave Communications for BellSouth property, which is stolen or damaged where an investigation determines the culpability of Clearwave Communications's employees, agents, or suppliers and where Clearwave Communications agrees, in good faith, with the results of such investigation. Clearwave Communications shall notify BellSouth in writing immediately in the event that the Clearwave Communications discovers one of its employees already working on the BellSouth Remote Site Location is a possible security risk. Upon request of the other Party, the Party who is the employer shall discipline consistent with its employment practices, up to and including removal from BellSouth's Remote Site Location, any employee found to have violated the security and safety requirements of this section. Clearwave Communications shall hold BellSouth harmless for any damages resulting from such removal of its personnel from BellSouth's Remote Site Location.
- 12.8 Use of Supplies. Unauthorized use of telecommunications equipment or supplies by either Party, whether or not used routinely to provide telephone service (e.g. plug-in cards,) will be strictly prohibited and handled appropriately. Costs associated with such unauthorized use may be charged to the offending Party, as may be all associated investigative costs.
- 12.9 Use of Official Lines. Except for non-toll calls necessary in the performance of their work, neither Party shall use the telephones of the other Party on the BellSouth Remote Site Location. Charges for unauthorized telephone calls may be charged to the offending Party, as may be all associated investigative costs.

12.10 Accountability. Full compliance with the Security requirements of this Section shall in no way limit the accountability of either Party to the other for the improper actions of its employees.

**13. Destruction of Remote Collocation Space**

13.1 In the event a Remote Collocation Space is wholly or partially damaged by fire, windstorm, tornado, flood or by similar causes to such an extent as to be rendered wholly unsuitable for Clearwave Communications's permitted use hereunder, then either Party may elect within ten (10) calendar days after such damage, to terminate this Attachment with respect to the affected Remote Collocation Space, and if either Party shall so elect, by giving the other written notice of termination, both Parties shall stand released of and from further liability under the terms hereof with respect to such Remote Collocation Space. If the Remote Collocation Space shall suffer only minor damage and shall not be rendered wholly unsuitable for Clearwave Communications's permitted use, or is damaged and the option to terminate is not exercised by either Party, BellSouth covenants and agrees to proceed promptly without expense to Clearwave Communications, except for improvements not to the property of BellSouth, to repair the damage. BellSouth shall have a reasonable time within which to rebuild or make any repairs, and such rebuilding and repairing shall be subject to delays caused by storms, shortages of labor and materials, government regulations, strikes, walkouts, and causes beyond the control of BellSouth, which causes shall not be construed as limiting factors, but as exemplary only. Clearwave Communications may, at its own expense, accelerate the rebuild of its Remote Collocation Space and equipment provided however that a BellSouth Certified Supplier is used and the necessary space preparation has been completed. Rebuild of equipment must be performed by a BellSouth Certified Vendor. If Clearwave Communications' s acceleration of the project increases the cost of the project, then those additional charges will be incurred by Clearwave Communications. Where allowed and where practical, Clearwave Communications may erect a temporary facility while BellSouth rebuilds or makes repairs. In all cases where the Remote Collocation Space shall be rebuilt or repaired, Clearwave Communications shall be entitled to an equitable abatement of rent and other charges, depending upon the unsuitability of the Remote Collocation Space for Clearwave Communications's permitted use, until such Remote Collocation Space is fully repaired and restored and Clearwave Communications's equipment installed therein (but in no event later than thirty (30) calendar days after the Remote Collocation Space is fully repaired and restored). Where Clearwave Communications has placed a Remote Site Adjacent Arrangement pursuant to Section 3.4, Clearwave Communications shall have the sole responsibility to repair or replace said Remote Site Adjacent Arrangement provided herein. Pursuant to this Section, BellSouth will restore the associated services to the Remote Site Adjacent Arrangement.

**14. Eminent Domain**

- 14.1 If the whole of a Remote Collocation Space or Remote Site Adjacent Arrangement shall be taken by any public authority under the power of eminent domain, then this Attachment shall terminate with respect to such Remote Collocation Space or Remote Site Adjacent Arrangement as of the day possession shall be taken by such public authority and rent and other charges for the Remote Collocation Space or Remote Site Adjacent Arrangement shall be paid up to that day with proportionate refund by BellSouth of such rent and charges as may have been paid in advance for a period subsequent to the date of the taking. If any part of the Remote Collocation Space or Remote Site Adjacent Arrangement shall be taken under eminent domain, BellSouth and Clearwave Communications shall each have the right to terminate this Attachment with respect to such Remote Collocation Space or Remote Site Adjacent Arrangement and declare the same null and void, by written notice of such intention to the other Party within ten (10) calendar days after such taking.

**15. Nonexclusivity**

- 15.1 Clearwave Communications understands that this Attachment is not exclusive and that BellSouth may enter into similar agreements with other Parties. Assignment of space pursuant to all such agreements shall be determined by space availability and made on a first come, first served basis.

## ENVIRONMENTAL AND SAFETY PRINCIPLES

The following principles provide basic guidance on environmental and safety issues when applying for and establishing Physical Collocation arrangements.

### 1. GENERAL PRINCIPLES

- 1.1 Compliance with Applicable Law. BellSouth and Clearwave Communications agree to comply with applicable federal, state, and local environmental and safety laws and regulations including U.S. Environmental Protection Agency (USEPA) regulations issued under the Clean Air Act (CAA), Clean Water Act (CWA), Resource Conservation and Recovery Act (RCRA), Comprehensive Environmental Response, Compensation and Liability Act (CERCLA), Superfund Amendments and Reauthorization Act (SARA), the Toxic Substances Control Act (TSCA), and OSHA regulations issued under the Occupational Safety and Health Act of 1970, as amended and NFPA and National Electrical Codes (NEC) and the NESC (“Applicable Laws”). Each Party shall notify the other if compliance inspections are conducted by regulatory agencies and/or citations are issued that relate to any aspect of this Attachment.
- 1.2 Notice. BellSouth and Clearwave Communications shall provide notice to the other, including Material Safety Data Sheets (MSDSs), of known and recognized physical hazards or Hazardous Chemicals existing on site or brought on site. A Hazardous Chemical inventory list is posted on an OSHA Poster and updated annually at each Central Office. This Poster is normally located near the front entrance of the building or in the lounge area. Each Party is required to provide specific notice for known potential Imminent Danger conditions. Clearwave Communications should contact 1-800-743-6737 for any BellSouth MSDS required.
- 1.3 Practices/Procedures. BellSouth may make available additional environmental control procedures for Clearwave Communications to follow when working at a BellSouth Remote Site Location (See Section 2, below). These practices/procedures will represent the regular work practices required to be followed by the employees and suppliers of BellSouth for environmental protection. Clearwave Communications will require its suppliers, agents and others accessing the BellSouth Remote Site Location to comply with these practices. Section 2 lists the Environmental categories where BST practices should be followed by Clearwave Communications when operating in the BellSouth Remote Site Location.
- 1.4 Environmental and Safety Inspections. BellSouth reserves the right to inspect the Clearwave Communications space with proper notification. BellSouth reserves the right to stop any Clearwave Communications work operation that imposes Imminent Danger to the environment, employees or other persons in the area or Remote Site Location.
- 1.5 Hazardous Materials Brought On Site. Any hazardous materials brought into, used, stored or abandoned at the BellSouth Remote Site Location by Clearwave Communications are owned by Clearwave Communications. Clearwave Communications will indemnify BellSouth for claims, lawsuits or damages to persons or property caused by these materials. Without prior written BellSouth approval, no substantial new safety or environmental hazards can be created by Clearwave



Communications or different hazardous materials used by Clearwave Communications at the BellSouth Remote Site Location. Clearwave Communications must demonstrate adequate emergency response capabilities for its materials used or remaining at the BellSouth Remote Site Location.

- 1.6 Spills and Releases. When contamination is discovered at a BellSouth Remote Site Location, either Party discovering the condition must notify the other Party. All Spills or Releases of regulated materials will immediately be reported by Clearwave Communications to BellSouth.
- 1.7 Coordinated Environmental Plans and Permits. BellSouth and Clearwave Communications will coordinate plans, permits or information required to be submitted to government agencies, such as emergency response plans, spill prevention control and countermeasures (SPCC) plans and community reporting. If fees are associated with filing, BellSouth and Clearwave Communications will develop a cost sharing procedure. If BellSouth’s permit or EPA identification number must be used, Clearwave Communications must comply with all of BellSouth’s permit conditions and environmental processes, including environmental “best management practices (BMP)” (see Section 2, below) and/or selection of BST disposition vendors and disposal sites.
- 1.8 Environmental and Safety Indemnification. BellSouth and Clearwave Communications shall indemnify, defend and hold harmless the other Party from and against any claims (including, without limitation, third-party claims for personal injury or death or real or personal property damage), judgments, damages, (including direct and indirect damages, and punitive damages), penalties, fines, forfeitures, costs, liabilities, interest and losses arising in connection with the violation or alleged violation of any Applicable Law or contractual obligation or the presence or alleged presence of contamination arising out of the acts or omissions of the indemnifying Party, its agents, suppliers, or employees concerning its operations at the Remote Site Location.

**2. CATEGORIES FOR CONSIDERATION OF ENVIRONMENTAL ISSUES**

- 2.1 When performing functions that fall under the following Environmental categories on BellSouth’s Remote Site Location, Clearwave Communications agrees to comply with the applicable sections of the current issue of BellSouth’s Environmental and Safety Methods and Procedures (M&Ps), incorporated herein by this reference. Clearwave Communications further agrees to cooperate with BellSouth to ensure that Clearwave Communications’s employees, agents, and/or suppliers are knowledgeable of and satisfy those provisions of BellSouth’s Environmental M&Ps which apply to the specific Environmental function being performed by Clearwave Communications, its employees, agents and/or suppliers.
- 2.1.1 The most current version of reference documentation must be requested from Clearwave Communications’s BellSouth Account Team Collocation Coordinator (ATCC) Representative.

ENVIRONMENTAL CATEGORIES	ENVIRONMENTAL ISSUES	ADDRESSED BY THE FOLLOWING DOCUMENTATION
Disposal of hazardous material or other regulated material	Compliance with all applicable local, state, & federal laws and	<ul style="list-style-type: none"> <li>• Std T&amp;C 450</li> </ul>

(e.g., batteries, fluorescent tubes, solvents & cleaning materials)	<p>regulations</p> <p>Pollution liability insurance</p> <p>EVET approval of supplier</p>	<ul style="list-style-type: none"> <li>• Fact Sheet Series 17000</li> <li>• Std T&amp;C 660-3</li> <li>• Approved Environmental Vendor List (Contact ATCC Representative)</li> </ul>
Emergency response	Hazmat/waste release/spill fire safety emergency	<ul style="list-style-type: none"> <li>• Fact Sheet Series 1700</li> <li>• Building Emergency Operations Plan (EOP) (specific to and located on Remote Site Location)</li> </ul>
Contract labor/outsourcing for services with environmental implications to be performed on BellSouth Remote Site Location (e.g., disposition of hazardous material/waste; maintenance of storage tanks)	<p>Compliance with all applicable local, state, &amp; federal laws and regulations</p> <p>Performance of services in accordance with BST's environmental M&amp;Ps</p> <p>Insurance</p>	<ul style="list-style-type: none"> <li>• Std T&amp;C 450</li> <li>• Std T&amp;C 450-B</li> <li>• (Contact ATCC Representative for copy of appropriate E/S M&amp;Ps.)</li> <li>• Std T&amp;C 660</li> </ul>
Transportation of hazardous material	<p>Compliance with all applicable local, state, &amp; federal laws and regulations</p> <p>Pollution liability insurance</p> <p>EVET approval of supplier</p>	<ul style="list-style-type: none"> <li>• Std T&amp;C 450</li> <li>• Fact Sheet Series 17000</li> <li>• Std T&amp;C 660-3</li> <li>• Approved Environmental Vendor List (Contact ATCC Representative)</li> </ul>
Maintenance/operations work which may produce a waste  Other maintenance work	<p>Compliance with all applicable local, state, &amp; federal laws and regulations</p> <p>Protection of BST employees and equipment</p>	<ul style="list-style-type: none"> <li>• Std T&amp;C 450</li> <li>• 29CFR 1910.147 (OSHA Standard)</li> <li>• 29CFR 1910 Subpart O (OSHA Standard)</li> </ul>
Janitorial services	<p>All waste removal and disposal must conform to all applicable federal, state and local regulations</p> <p>All Hazardous Material and Waste</p>	<ul style="list-style-type: none"> <li>• –Procurement Manager (CRES Related Matters)-BST Supply Chain Services</li> </ul>

	Asbestos notification and protection of employees and equipment	<ul style="list-style-type: none"> <li>• Fact Sheet Series 17000</li> <li>• GU-BTEN-001BT, Chapter 3</li> <li>• BSP 010-170-001BS (Hazcom)</li> </ul>
Manhole cleaning	<p>Compliance with all applicable local, state, &amp; federal laws and regulations</p> <p>Pollution liability insurance</p> <p>EVET approval of supplier</p>	<ul style="list-style-type: none"> <li>• Std T&amp;C 450</li> <li>• Fact Sheet 14050</li> <li>• BSP 620-145-011PR Issue A, August 1996</li> <li>• Std T&amp;C 660-3</li> <li>• Approved Environmental Vendor List (Contact ATCC Representative)</li> </ul>
Removing or disturbing building materials that may contain asbestos	Asbestos work practices	<ul style="list-style-type: none"> <li>• GU-BTEN-001BT, Chapter 3</li> </ul> <p>For questions regarding removing or disturbing materials that contain asbestos, call the BellSouth Building Service Center: AL, MS, TN, KY &amp; LA (local area code) 557-6194 FL, GA, NC &amp; SC (local area code) 780-2740</p>

### 3. DEFINITIONS

Generator. Under RCRA, the person whose act produces a Hazardous Waste, as defined in 40 CFR 261, or whose act first causes a Hazardous Waste to become subject to regulation. The Generator is legally responsible for the proper management and disposal of Hazardous Wastes in accordance with regulations.

Hazardous Chemical. As defined in the U.S. Occupational Safety and Health (OSHA) hazard communication standard (29 CFR 1910.1200), any chemical which is a health hazard or physical hazard.

Hazardous Waste. As defined in section 1004 of RCRA.

Imminent Danger. Any conditions or practices at a remote site location which are such that a danger exists which could reasonably be expected to cause immediate death or serious harm to people or immediate significant damage to the environment or natural resources.

Spill or Release. As defined in Section 101 of CERCLA.

#### 4. ACRONYMS

ATCC – Account Team Collocation Coordinator

BST – BellSouth Telecommunications

CRES – Corporate Real Estate and Services (formerly PS&M)

DEC/LDEC - Department Environmental Coordinator/Local Department Environmental Coordinator

E/S – Environmental/Safety

EVET - Environmental Vendor Evaluation Team

GU-BTEN-001BT - BellSouth Environmental Methods and Procedures

NESC - National Electrical Safety Codes

P&SM - Property & Services Management

Std T&C - Standard Terms & Conditions

COLLOCATION - Kentucky											Attachment: 4		Exhibit: B		
CATEGORY	RATE ELEMENTS	Interim	Zone	BCS	USOC	RATES (\$)				Svc Order Submitted Elec per LSR	Svc Order Submitted Manually per LSR	Incremental Charge - Manual Svc Order vs. Electronic-1st	Incremental Charge - Manual Svc Order vs. Electronic-Add'l	Incremental Charge - Manual Svc Order vs. Electronic-Disc 1st	Incremental Charge - Manual Svc Order vs. Electronic-Disc Add'l
						Rec	Nonrecurring		Nonrecurring Disconnect						
							First	Add'l	First	Add'l	SOMEc	SOMAN	SOMAN	SOMAN	SOMAN
<b>PHYSICAL COLLOCATION</b>															
	Physical Collocation 2-Wire Cross Connect, Exchange Port 2-Wire Analog - Res			UEPSR	PE1R2	0.0333	24.68	23.68	12.14	10.95		7.86			
	Physical Collocation 2-Wire Cross Connect, Exchange Port 2-Wire Line Side PBX Trunk - Bus			UEPSP	PE1R2	0.0333	24.68	23.68	12.14	10.95		7.86			
	Physical Collocation 2-Wire Cross Connect, Exchange Port 2-Wire Voice Grade PBX Trunk - Res			UEPSE	PE1R2	0.0333	24.68	23.68	12.14	10.95		7.86			
	Physical Collocation 2-Wire Cross Connect, Exchange Port 2-Wire Analog - Bus			UEPSB	PE1R2	0.0333	24.68	23.68	12.14	10.95		7.86			
	Physical Collocation 2-Wire Cross Connect, Exchange Port 2-Wire ISDN			UEPSX	PE1R2	0.0333	24.68	23.68	12.14	10.95		7.86			
	Physical Collocation 2-Wire Cross Connect, Exchange Port 2-Wire ISDN			UEPTX	PE1R2	0.0333	24.68	23.68	12.14	10.95		7.86			
	Physical Collocation 4-Wire Cross Connect, Exchange Port 4-Wire ISDN DS1			UEPEX	PE1R4	1.48	44.23	31.98	12.81	11.57		7.86			
<b>PHYSICAL COLLOCATION</b>															
	Physical Collocation - Application Fee - Initial			CLO	PE1BA		3,773.54	3,773.54							
	Physical Collocation - Application Fee - Subsequent			CLO	PE1CA		3,145.35	3,145.35							
	Physical Collocation Administrative Only - Application Fee			CLO	PE1BL		742.12								
	Physical Collocation - Space Preparation - Firm Order Processing			CLO	PE1SJ		1,206.07	1,206.07							
	Physical Collocation - Space Preparation - C.O. Modification per square ft.			CLO	PE1SK	2.32									
	Physical Collocation - Space Preparation - Common Systems Modification per square ft. - Cageless			CLO	PE1SL	3.26									
	Physical Collocation - Space Preparation - Common Systems Modification per Cage			CLO	PE1SM	110.57									
	Physical Collocation - Cable Installation			CLO	PE1BD		1,729.11		45.16						
	Physical Collocation - Floor Space per Sq. Ft.			CLO	PE1PJ	7.99									
	Physical Collocation - Cable Support Structure, Per Entrance Cable			CLO	PE1PM	19.86									
	Physical Collocation - Power -48V DC Power, per Fused Amp			CLO	PE1PL	8.06									
	Physical Collocation - Power Reduction, Application Fee	I		CLO	PE1PR		399.50								
	Physical Collocation - 120V, Single Phase Standby Power Rate			CLO	PE1FB	5.44									
	Physical Collocation - 240V, Single Phase Standby Power Rate			CLO	PE1FD	10.88									
	Physical Collocation - 120V, Three Phase Standby Power Rate			CLO	PE1FE	16.32									
	Physical Collocation - 277V, Three Phase Standby Power Rate			CLO	PE1FG	37.68									
	Physical Collocation - 2-Wire Cross-Connects			UEANL,UEA,UDN,UDC,UAL,UHL,UCL,U EQ, UDL, UNCVX, UNLDX, UNCNX	PE1P2	0.0333	24.68	23.68	12.14	10.95					
	Physical Collocation - 4-Wire Cross-Connects			CLO, UAL, UDL, UDN, UEA, UHL, UNCVX, UNCDX, UCL	PE1P4	0.0665	24.88	23.82	12.77	11.46					
	Physical Collocation - DS1 Cross-Connects			CLO,UEANL,UEQ,WDS1L,WDS1S, USL, U1TD1, UXTD1, UNC1X, ULDD1, USLEL, UNLD1, UDL	PE1P1	1.48	44.23	31.98	12.81	11.57					

**COLLOCATION - Kentucky**

CATEGORY	RATE ELEMENTS	Interim	Zone	BCS	USOC	RATES (\$)	Svc Order Submitted Elec per LSR	Svc Order Submitted Manually per LSR	Attachment: 4		Exhibit: B					
									Incremental Charge - Manual Svc Order vs. Electronic-1st	Incremental Charge - Manual Svc Order vs. Electronic-Add'l	Incremental Charge - Manual Svc Order vs. Electronic-Disc 1st	Incremental Charge - Manual Svc Order vs. Electronic-Disc Add'l				
									Rec	Nonrecurring		Nonrecurring Disconnect		OSS Rates (\$)		
						First	Add'l	First	Add'l	SOMEC	SOMAN	SOMAN	SOMAN	SOMAN	SOMAN	
	Physical Collocation - DS3 Cross-Connects			CLO, UE3,U1TD3, UXTD3, UXTS1, UNC3X, UNCSX, ULDD3, U1TS1,ULDS1, UNLD3, UDL	PE1P3	18.89	41.93	30.51	14.75	11.83						
	Physical Collocation - 2-Fiber Cross-Connect			CLO, ULDO3, ULD12, ULD48, U1TO3, U1T12, U1T48, UDLO3, UDL12, UDF	PE1F2	3.75	41.93	30.51	14.76	11.84						
	Physical Collocation - 4-Fiber Cross-Connect			CLO, ULDO3, ULD12, ULD48, U1TO3, U1T12, U1T48, UDLO3, UDL12, UDF	PE1F4	6.65	51.29	39.87	19.41	16.49						
	Physical Collocation - Welded Wire Cage - First 100 Sq. Ft.			CLO	PE1BW	184.97										
	Physical Collocation - Welded Wire Cage - Add'l 50 Sq. Ft.			CLO	PE1CW	18.14										
	Physical Collocation - Security Access System - Security System per Central Office			CLO	PE1AX	76.10										
	Physical Collocation - Security Access System - New Access Card Activation, per Card			CLO	PE1A1	0.058	55.79	55.79								
	Physical Collocation-Security Access System-Administrative Change, existing Access Card, per Request, per State, per Card			CLO	PE1AA		15.64	15.64								
	Physical Collocation - Security Access System - Replace Lost or Stolen Card, per Card			CLO	PE1AR		45.74	45.74								
	Physical Collocation - Security Access - Initial Key, per Key			CLO	PE1AK		26.29	26.29								
	Physical Collocation - Security Access - Key, Replace Lost or Stolen Key, per Key			CLO	PE1AL		26.29	26.29								
	Physical Collocation - Space Availability Report per premises			CLO	PE1SR		2,158.67	2,158.67								
	POT Bay Arrangements prior to 6/1/99 - 2-Wire Cross-Connect, per cross-connect			UEANL,UEA,UDN,U DC,UAL,UHL,UCL,U EQ,CLO,UDL, UNCVX, UNCDX, UNCNX	PE1PE	0.113										
	POT Bay Arrangements prior to 6/1/99 - 4-Wire Cross-Connect, per cross-connect			UEANL,UEA,UDN,U DC,UAL,UHL,UCL,U EQ,CLO, USL, UNCVX, UNCDX	PE1PF	0.23										
	POT Bay Arrangements prior to 6/1/99 - DS1 Cross-Connect, per cross-connect			UEANL,UEA,UDN,U DC,UAL,UHL,UCL,U EQ,CLO,WDS1L,W DS1S, USL, U1TD1, UXTD1, UNC1X, ULDD1, USLEL, UNLD1	PE1PG	1.60										
	POT Bay Arrangements prior to 6/1/99 - DS3 Cross-Connect, per cross-connect			UEANL,UEA,UDN,U DC,UAL,UHL,UCL,U EQ,CLO,UE3, U1TD3, UXTD3, UXTS1, UNC3X, UNCSX, ULDD3, U1TS1, ULDS1, UNLD3, UDL, UDLSX	PE1PH	14.23										

COLLOCATION - Kentucky										Attachment: 4		Exhibit: B			
CATEGORY	RATE ELEMENTS	Interim	Zone	BCS	USOC	RATES (\$)	Svc Order Submitted Elec per LSR	Svc Order Submitted Manually per LSR	Incremental Charge - Manual Svc Order vs. Electronic-1st	Incremental Charge - Manual Svc Order vs. Electronic-Add'l	Incremental Charge - Manual Svc Order vs. Electronic-Disc 1st	Incremental Charge - Manual Svc Order vs. Electronic-Disc Add'l			
													Rec	Nonrecurring	
										SOMEc	SOMAN	SOMAN	SOMAN	SOMAN	SOMAN
	POT Bay Arrangements prior to 6/1/99 - 2-Fiber Cross-Connect, per cross-connect			UEANL,UEA,UDN,U DC,UAL,UHL,UCL,U EQ,CLO, ULDO3, ULD12, ULD48, U1TO3, U1T12, U1T48, UDLO3, UDL12, UDF	PE1B2	48.57									
	POT Bay Arrangements prior to 6/1/99 - 4-Fiber Cross-Connect, per cross-connect			UEANL,UEA,UDN,U DC,UAL,UHL,UCL,U EQ,CLO, ULDO3, ULD12, ULD48, U1TO3, U1T12, U1T48, UDLO3, UDL12, UDF	PE1B4	65.50									
	Physical Collocation - Request Resend of CFA Information, per CLLI			CLO	PE1C9										
	Nonrecurring Collocation Cable Records - per request			CLO	PE1CR										
	Nonrecurring Collocation Cable Records - VG/DS0 Cable, per cable record			CLO	PE1CD										
	Nonrecurring Collocation Cable Records - VG/DS0 Cable, per each 100 pair			CLO	PE1CO										
	Nonrecurring Collocation Cable Records - DS1, per T1TIE			CLO	PE1C1										
	Nonrecurring Collocation Cable Records - DS3, per T3TIE			CLO	PE1C3										
	Nonrecurring Collocation Cable Records - Fiber Cable, per 99 fiber records			CLO	PE1CB										
	Physical Collocation - Security Escort - Basic, per Half Hour			CLO,CLORS	PE1BT										
	Physical Collocation - Security Escort - Overtime, per Half Hour			CLO,CLORS	PE1OT										
	Physical Collocation - Security Escort - Premium, per Half Hour			CLO,CLORS	PE1PT										
	V to P Conversion, Per Customer Request-Voice Grade			CLO	PE1BV										
	V to P Conversion, Per Customer Request-DS0			CLO	PE1BO										
	V to P Conversion, Per Customer Request-DS1			CLO	PE1B1										
	V to P Conversion, Per Customer request-DS3			CLO	PE1B3										
	V to P Conversion, Per Customer Request per VG Circuit Reconfigured			CLO	PE1BR										
	V to P Conversion, Per Customer Request per DS0 Circuit Reconfigured			CLO	PE1BP										
	V to P Conversion, Per Customer Request per DS1 Circuit Reconfigured			CLO	PE1BS										
	V to P Conversion, Per Customer Request per DS3 Circuit Reconfigured			CLO	PE1BE										
	V to P Conversion, Cable Pairs Assigned to Collo Space per 700 prs or fraction thereof			CLO	PE1B7										
	Physical Collocation - Co-Carrier Cross Connects - Fiber Cable Support Structure, per cable, per linear ft.			CLO,UDF	PE1ES	0.0012									
	Physical Collocation - Co-Carrier Cross Connects - Copper/Coax Cable Support Structure, per cable, per lin. ft.			CLO, UE3, USL	PE1DS	0.0018									
	Physical Collocation - Co-Carrier Cross Connects Only - Application Fee, per application			CLO	PE1DT										
	Physical Collocation - Application to Augment Existing Space - Simple			CLO	PE1KS										
	Physical Collocation - Application to Augment Existing Space - Minor			CLO	PE1KM										
	Physical Collocation - Application to Augment Existing Space - Intermediate			CLO	PE1K1										
<b>ADJACENT COLLOCATION</b>															
	Adjacent Collocation - Space Charge per Sq. Ft.			CLOAC	PE1JA	0.0173									
	Adjacent Collocation - Electrical Facility Charge per Linear Ft.			CLOAC	PE1JC	5.35									

**COLLOCATION - Kentucky**

CATEGORY	RATE ELEMENTS	Interim	Zone	BCS	USOC	RATES (\$)	Svc Order Submitted Elec per LSR	Svc Order Submitted Manually per LSR	Attachment: 4		Exhibit: B					
									Incremental Charge - Manual Svc Order vs. Electronic-1st	Incremental Charge - Manual Svc Order vs. Electronic-Add'l	Incremental Charge - Manual Svc Order vs. Electronic-Disc 1st	Incremental Charge - Manual Svc Order vs. Electronic-Disc Add'l				
									Rec	Nonrecurring		Nonrecurring Disconnect		OSS Rates (\$)		
						First	Add'l	First	Add'l	SOMEC	SOMAN	SOMAN	SOMAN	SOMAN	SOMAN	
	Adjacent Collocation - 2-Wire Cross-Connects			CLOAC	PE1P2	0.0258	24.68	23.68	12.14	10.95						
	Adjacent Collocation - 4-Wire Cross-Connects			UEA,UHL,UDL,UCL,CLOAC	PE1P4	0.0515	24.88	23.82	12.77	11.46						
	Adjacent Collocation - DS1 Cross-Connects			USL,CLOAC	PE1P1	1.37	44.23	31.98	12.81	11.57						
	Adjacent Collocation - DS3 Cross-Connects			CLOAC	PE1P3	18.61	41.93	30.51	14.75	11.83						
	Adjacent Collocation - 2-Fiber Cross-Connect			CLOAC	PE1F2	3.15	41.93	30.51	14.76	11.84						
	Adjacent Collocation - 4-Fiber Cross-Connect			CLOAC	PE1F4	6.02	51.29	39.87	19.41	16.49						
	Adjacent Collocation - Application Fee			CLOAC	PE1JB		3,165.50									
	Adjacent Collocation - 120V, Single Phase Standby Power Rate per AC Breaker Amp			CLOAC	PE1FB	5.44										
	Adjacent Collocation - 240V, Single Phase Standby Power Rate per AC Breaker Amp			CLOAC	PE1FD	10.88										
	Adjacent Collocation - 120V, Three Phase Standby Power Rate per AC Breaker Amp			CLOAC	PE1FE	16.32										
	Adjacent Collocation - 277V, Three Phase Standby Power Rate per AC Breaker Amp			CLOAC	PE1FG	37.68										
<b>PHYSICAL COLLOCATION IN THE REMOTE SITE</b>																
	Physical Collocation in the Remote Site - Application Fee			CLOAC	PE1RA		617.78		338.89							
	Cabinet Space in the Remote Site per Bay/ Rack			CLOAC	PE1RB	219.67										
	Physical Collocation in the Remote Site - Security Access - Key			CLOAC	PE1RD		26.29									
	Physical Collocation in the Remote Site - Space Availability Report per Premises Requested			CLOAC	PE1SR		232.64									
	Physical Collocation in the Remote Site - Remote Site CLLI Code Request, per CLLI Code Requested			CLOAC	PE1RE		75.40									
	Remote Site DLEC Data (BRSD), per Compact Disk, per CO			CLOAC	PE1RR		233.42									
<b>PHYSICAL COLLOCATION IN THE REMOTE SITE - ADJACENT</b>																
	Remote Site-Adjacent Collocation - AC Power, per breaker amp			CLOAC	PE1RS	6.27										
	Remote Site-Adjacent Collocation - Real Estate, per square foot			CLOAC	PE1RT	0.134										
	Remote Site-Adjacent Collocation-Application Fee			CLOAC	PE1RU		755.62	755.62								
<b>NOTE: If Security Escort and/or Add'l Engineering Fees become necessary for remote site collocation, the Parties will negotiate appropriate rates.</b>																
<b>VIRTUAL COLLOCATION</b>																
	Virtual Collocation - Application Fee			AMTFS	EAF		2,419.86	2,419.86	1.01	1.01						7.86
	Virtual Collocation - Cable Installation Cost, per cable			AMTFS	ESPCX		1,729.11	1,729.11	45.16	45.16						7.86
	Virtual Collocation - Floor Space, per sq. ft.			AMTFS	ESPVX	7.99										
	Virtual Collocation - Power, per fused amp			AMTFS	ESPAX	8.06										
	Virtual Collocation - Cable Support Structure, per entrance cable			AMTFS	ESPSX	17.38										
	Virtual Collocation - 2-wire Cross Connects (loop)			UEANL,UEA,UDN,U DC,UAL,UHL,UCL,U EQ, AMTFS, UDL, UNCVX, UNCDX, UNCNX	UEAC2	0.0309	24.68	23.68	12.14	10.95						7.86
	Virtual Collocation - 4-wire Cross Connects (loop)			UEA,UHL,UCL,UDL, AMTFS, UAL, UDN, UNCVX, UNCDX	UEAC4	0.0619	24.88	23.82	12.77	11.46						7.86
	Virtual Collocation - 2-Fiber Cross Connects			AMTFS,UDL12, UDLO3, U1T48, U1T12, U1T03, ULDO3, ULD12, ULD48, UDF	CNC2F	3.80	41.94	30.51	14.76	11.84						7.86
	Virtual Collocation - 4-Fiber Cross Connects			AMTFS,UDL12, UDLO3, U1T48, U1T12, U1T03, ULDO3, ULD12, ULD48, UDF	CNC4F	7.59	51.29	39.87	19.41	16.49						7.86



**COLLOCATION - Kentucky**

COLLOCATION - Kentucky							Attachment: 4		Exhibit: B							
CATEGORY	RATE ELEMENTS	Interim	Zone	BCS	USOC	RATES (\$)	Svc Order Submitted Elec per LSR	Svc Order Submitted Manually per LSR	Incremental Charge - Manual Svc Order vs. Electronic-1st	Incremental Charge - Manual Svc Order vs. Electronic-Add'l	Incremental Charge - Manual Svc Order vs. Electronic-Disc 1st	Incremental Charge - Manual Svc Order vs. Electronic-Disc Add'l				
							Rec	Nonrecurring		Nonrecurring Disconnect		OSS Rates (\$)				
							First	Add'l	First	Add'l	SOMEC	SOMAN	SOMAN	SOMAN	SOMAN	SOMAN
	Virtual collocation - Special Access & UNE, cross-connect per DS1			USL, ULC, AMTFS, ULR, UXTD1, UNC1X, ULDD1, U1TD1, USLEL, UNLD1	CNC1X	1.48	44.23	31.98	12.81	11.57						
	Virtual collocation - Special Access & UNE, cross-connect per DS3			USL, ULC, AMTFS, UE3, U1TD3, UXTS1, UXTD3, UNC3X, UNCSX, ULDD3, U1TS1, ULDS1, UDLSX, UNLD3	CND3X	18.89	41.93	30.51	14.75	11.83						
	Virtual Collocation - Co-Carrier Cross Connects - Fiber Cable Support Structure, per linear foot			AMTFS	VE1CB	0.003										
	Virtual Collocation - Co-Carrier Cross Connects - Copper/Coax Cable Support Structure, per linear ft			AMTFS	VE1CD	0.0045										
	Virtual Collocation - Co-Carrier Cross Connects - Fiber Cable Support Structure, per cable			AMTFS	VE1CC		535.55									
	Virtual Collocation - Co-Carrier Cross Connects - Copper/Coax Cable Support Structure, per cable			AMTFS	VE1CE		535.55									
	Virtual Collocation Cable Records - per request			AMTFS	VE1BA		1,524.45	980.01	267.02	267.02						
	Virtual Collocation Cable Records - VG/DS0 Cable, per cable record			AMTFS	VE1BB		656.37	656.37	379.70	379.70						
	Virtual Collocation Cable Records - VG/DS0 Cable, per each 100 pair			AMTFS	VE1BC		9.65	9.65	11.84	11.84						
	Virtual Collocation Cable Records - DS1, per T1TIE			AMTFS	VE1BD		4.52	4.52	5.54	5.54						
	Virtual Collocation Cable Records - DS3, per T3TIE			AMTFS	VE1BE		15.81	15.81	19.39	19.39						
	Virtual Collocation Cable Records - Fiber Cable, per 99 fiber records			AMTFS	VE1BF		169.63	169.63	154.85	154.85						
	Virtual collocation - Security Escort - Basic, per half hour			AMTFS	SPTBX		33.98	21.53								
	Virtual collocation - Security Escort - Overtime, per half hour			AMTFS	SPTOX		44.26	27.81								
	Virtual collocation - Security Escort - Premium, per half hour			AMTFS	SPTPX		54.54	34.09								
	Virtual collocation - Maintenance in CO - Basic, per half hour			AMTFS	CTRLX		56.07	21.53								
	Virtual collocation - Maintenance in CO - Overtime, per half hour			AMTFS	SPTOM		73.23	27.81								
	Virtual collocation - Maintenance in CO - Premium per half hour			AMTFS	SPTPM		90.39	34.09								
<b>VIRTUAL COLLOCATION</b>																
	Virtual Collocation - 2-wire Cross Connect, Exchange Port 2-Wire Analog - Res			UEPSR	VE1R2	0.0309	24.68	23.68	12.14	10.95		7.86				
	Virtual Collocation 2-Wire Cross Connect, Exchange Port 2-Wire Line Side PBX Trunk - Bus			UEPSP	VE1R2	0.0309	24.68	23.68	12.14	10.95		7.86				
	Virtual Collocation 2-Wire Cross Connect, Exchange Port 2-Wire Voice Grade PBX Trunk - Res			UEPSE	VE1R2	0.0309	24.68	23.68	12.14	10.95		7.86				
	Virtual Collocation 2-Wire Cross Connect, Exchange Port 2-Wire Analog Bus			UEPSB	VE1R2	0.0309	24.68	23.68	12.14	10.95		7.86				
	Virtual Collocation 2-Wire Cross Connect, Exchange Port 2-Wire ISDN			UEPSX	VE1R2	0.0309	24.68	23.68	12.14	10.95		7.86				
	Virtual Collocation 2-Wire Cross Connect, Exchange Port 2-Wire ISDN			UEPTX	VE1R2	0.0309	24.68	23.68	12.14	10.95		7.86				
	Virtual Collocation 4-Wire Cross Connect, Exchange Port 4-Wire ISDN DS1			UEPEX	VE1R4	1.48	44.23	31.98	12.81	11.57		7.86				

Note: Rates displaying an "R" in Interim column are interim and subject to rate true-up as set forth in General Terms and Conditions.

## **Attachment 5**

### **Access to Numbers and Number Portability**

**TABLE OF CONTENTS**

**1. NON-DISCRIMINATORY ACCESS TO TELEPHONE NUMBERS..... 3**

**2. LOCAL SERVICE PROVIDER NUMBER PORTABILITY - PERMANENT SOLUTION (LNP)..... 3**

**3. OPERATIONAL SUPPORT SYSTEM (OSS) RATES..... 4**

## **ACCESS TO NUMBERS AND NUMBER PORTABILITY**

### **1. NON-DISCRIMINATORY ACCESS TO TELEPHONE NUMBERS**

- 1.1 During the term of this Agreement, where Clearwave Communications is utilizing its own switch, Clearwave Communications shall contact the North American Numbering Plan Administrator, NeuStar, for the assignment of numbering resources. In order to be assigned a Central Office Code, Clearwave Communications will be required to complete the Central Office Code (NXX) Assignment Request and Confirmation Form (Code Request Form) in accordance with Industry Numbering Committee's Central Office Code (NXX) Assignment Guidelines (INC 95-0407-008).
- 1.2 Where BellSouth provides local switching or resold services to Clearwave Communications, BellSouth will provide Clearwave Communications with on-line access to intermediate telephone numbers as defined by applicable FCC rules and regulations on a first come first served basis. Clearwave Communications acknowledges that such access to numbers shall be in accordance with the appropriate FCC rules and regulations. Clearwave Communications acknowledges that there may be instances where there is a shortage of telephone numbers in a particular rate center; and in such instances, BellSouth may request that Clearwave Communications return unused intermediate numbers to BellSouth. Clearwave Communications shall return unused intermediate numbers to BellSouth upon BellSouth's request. BellSouth shall make all such requests on a nondiscriminatory basis.
- 1.3 BellSouth will allow Clearwave Communications to designate up to 100 intermediate telephone numbers per rate center for Clearwave Communications's sole use. Assignment, reservation and use of telephone numbers shall be governed by applicable FCC rules and regulations. Clearwave Communications acknowledges that there may be instances where there is a shortage of telephone numbers in a particular rate center and BellSouth has the right to limit access to blocks of intermediate telephone numbers. These instances include: 1) where jeopardy status has been declared by the North American Numbering Plan (NANP) for a particular Numbering Plan Area (NPA); or 2) where a rate center has less than six months supply of numbering resources.

### **2. LOCAL SERVICE PROVIDER NUMBER PORTABILITY - PERMANENT SOLUTION (LNP)**

- 2.1 The Parties will offer Number Portability in accordance with rules, regulations and guidelines adopted by the Commission, the FCC and industry fora.

- 2.2 End User Line Charge. Where Clearwave Communications subscribes to BellSouth's local switching, BellSouth shall bill and Clearwave Communications shall pay the end user line charge associated with implementing LNP as set forth in BellSouth's FCC Tariff No. 1. This charge is not subject to the resale discount set forth in Attachment 1 of this Agreement.
- 2.3 To limit service outage, BellSouth and Clearwave Communications will adhere to the process flows and cutover guidelines for porting numbers as outlined in the LNP Reference Guide, as amended from time to time. The LNP Reference Guide, incorporated herein by reference, is accessible via the Internet at the following site: <http://www.interconnection.bellsouth.com>. All intervals referenced in the LNP Reference Guide shall apply to both BellSouth and Clearwave Communications.
- 2.4 The Parties will set Location Routing Number (LRN) unconditional or 10-digit triggers where applicable. Where triggers are set, the porting Party will remove the ported number at the same time the trigger is removed.
- 2.5 A trigger order is a service order issued in advance of the porting of a number. A trigger order 1) initiates call queries to the AIN SS7 network in advance of the number being ported; and 2) provides for the new service provider to be in control of when a number ports.
- 2.6 Where triggers are not set, the Parties shall coordinate the porting of the number between service providers so as to minimize service interruptions to the End User.
- 2.7 BellSouth and Clearwave Communications will work cooperatively to implement changes to LNP process flows ordered by the FCC or as recommended by standard industry forums addressing LNP.

### **3. OPERATIONAL SUPPORT SYSTEM (OSS) RATES**

- 3.1 The terms, conditions and rates for OSS are as set forth in Attachment 2.

**Attachment 6**  
**Pre-Ordering, Ordering, Provisioning,  
Maintenance and Repair**

**TABLE OF CONTENTS**

1. QUALITY OF PRE-ORDERING, ORDERING, PROVISIONING, MAINTENANCE AND REPAIR ... 3

2. ACCESS TO OPERATIONS SUPPORT SYSTEMS ..... 3

3. MISCELLANEOUS ..... 5

## **PRE-ORDERING, ORDERING, PROVISIONING, MAINTENANCE AND REPAIR**

### **1. QUALITY OF PRE-ORDERING, ORDERING, PROVISIONING, MAINTENANCE AND REPAIR**

1.1 BellSouth shall provide pre-ordering, ordering, provisioning, and maintenance and repair services to Clearwave Communications that are equivalent to the pre-ordering, ordering, provisioning, and maintenance and repair services BellSouth provides to itself or any other CLEC where technically feasible. The guidelines for pre-ordering, ordering, provisioning, and maintenance and repair are set forth in the various guides and business rules, as appropriate, and as they are amended from time to time during this Agreement. The guides and business rules are found at <http://www.interconnection.bellsouth.com> and are incorporated herein by reference.

1.2 BellSouth shall provision services during its regular working hours. To the extent Clearwave Communications requests provisioning of service to be performed outside BellSouth's regular working hours, or the work so requested requires BellSouth's technicians or Project Manager to work outside of regular working hours, overtime charges shall apply. Notwithstanding the foregoing, if such work is performed outside of regular working hours by a BellSouth technician or Project Manager during his or her scheduled shift and BellSouth does not incur any overtime charges in performing the work on behalf of Clearwave Communications, BellSouth will not assess Clearwave Communications additional charges beyond the rates and charges specified in this Agreement.

### **2. ACCESS TO OPERATIONS SUPPORT SYSTEMS**

2.1 BellSouth shall provide Clearwave Communications access to operations support systems (OSS) functions for pre-ordering, ordering, provisioning, maintenance and repair, and billing. BellSouth shall provide access to the OSS through manual and/or electronic interfaces as described in this Attachment. It is the sole responsibility of Clearwave Communications to obtain the technical capability to access and utilize BellSouth's OSS interfaces. Specifications for Clearwave Communications's access and use of BellSouth's electronic interfaces are set forth at [www.interconnection.bellsouth.com](http://www.interconnection.bellsouth.com) and are incorporated herein by reference.

2.1.1 Pre-Ordering. In accordance with FCC and Commission rules and orders, BellSouth will provide electronic access to the following pre-ordering functions: service address validation, telephone number selection, service and feature availability, due date information, customer record information and loop makeup information. Access is provided through the Local Exchange Navigation System (LENS) interface and the Telecommunications Access Gateway (TAG) interface. Customer record information includes customer specific information in CRIS and RSAG. Clearwave Communications shall provide to BellSouth access to customer



record information, including circuit numbers associated with each telephone number where applicable. Clearwave Communications shall provide such information within four (4) hours after request via electronic access where available. If electronic access is not available, Clearwave Communications shall provide to BellSouth paper copies of customer record information, including circuit numbers associated with each telephone number where applicable. If BellSouth requests the information before noon, the customer record information shall be provided the same day. If BellSouth requests the information after noon, the customer record information shall be provided by noon the following day.

- 2.1.2 The Parties agree not to view, copy, or otherwise obtain access to the customer record information of any customer without that customer's permission. Clearwave Communications will obtain access to customer record information only in strict compliance with applicable laws, rules, or regulations of the state in which the service is provided. BellSouth reserves the right to audit Clearwave Communications's access to customer record information. If a BellSouth audit of Clearwave Communications's access to customer record information reveals that Clearwave Communications is accessing customer record information without having obtained the proper End User authorization, BellSouth upon reasonable notice to Clearwave Communications may take corrective action, including but not limited to suspending or terminating Clearwave Communications's electronic access to BellSouth's OSS functionality. All such information obtained through an audit shall be deemed Information covered by the Proprietary and Confidential Information section in the General Terms and Conditions of this Agreement.
- 2.1.3 Service Ordering. BellSouth will make available the Electronic Data Interchange (EDI) interface and the TAG ordering interface for the purpose of exchanging order information, including order status and completion notification, for non-complex and certain complex resale requests and certain network elements. Clearwave Communications may integrate the EDI interface or the TAG ordering interface with the TAG pre-ordering interface. In addition, BellSouth will provide integrated pre-ordering and ordering capability through the LENS interface for non-complex and certain complex resale service requests and certain network element requests.
- 2.1.4 Maintenance and Repair. Clearwave Communications may report and monitor service troubles and obtain repair services from BellSouth via electronic interfaces. BellSouth provides several options for electronic trouble reporting. For exchange services, BellSouth offers Clearwave Communications non-discriminatory access to the Trouble Analysis Facilitation Interface (TAFI). In addition, BellSouth offers an industry standard, machine-to-machine Electronic Communications Trouble Administration (ECTA) Gateway interface. For designed services, BellSouth provides non-discriminatory trouble reporting via the ECTA Gateway. BellSouth provides Clearwave Communications an estimated time to repair, an appointment time or a commitment time, as appropriate, on trouble reports. Requests for trouble repair are billed in accordance with the provisions of this Agreement. BellSouth and Clearwave Communications agree to adhere to BellSouth's

Operational Understanding, as amended from time to time during this Agreement and as incorporated herein by reference. The Operational Understanding may be accessed via the Internet at <http://www.interconnection.bellsouth.com>.

- 2.2 Change Management. BellSouth provides a collaborative process for change management of the electronic interfaces through the Change Control Process (CCP). Guidelines for this process are set forth in the CCP document as amended from time to time during this Agreement. The CCP document may be accessed via the Internet at <http://www.interconnection.bellsouth.com>.
- 2.3 BellSouth's Versioning Policy for Electronic Interfaces. BellSouth's Versioning Policy is part of the Change Control Process (CCP). Pursuant to the CCP, BellSouth will issue new software releases for new industry standards for its EDI and TAG electronic interfaces. The Versioning Policy, including the appropriate notification to Clearwave Communications, is set forth in the CCP document as amended from time to time during this Agreement. The CCP document may be accessed via the Internet at <http://www.interconnection.bellsouth.com>.
- 2.4 Rates. Charges for use of OSS shall be as set forth in this Agreement.

### **3. MISCELLANEOUS**

- 3.1 Pending Orders. Orders placed in the hold or pending status by Clearwave Communications will be held for a maximum of thirty (30) days from the date the order is placed on hold. After such time, Clearwave Communications shall be required to submit a new service request. Incorrect or invalid requests returned to Clearwave Communications for correction or clarification will be held for thirty (30) days. If Clearwave Communications does not return a corrected request within thirty (30) days, BellSouth will cancel the request.
- 3.2 Single Point of Contact. Clearwave Communications will be the single point of contact with BellSouth for ordering activity for network elements and other services used by Clearwave Communications to provide services to its End Users, except that BellSouth may accept a request directly from another CLEC, or BellSouth, acting with authorization of the affected End User. Clearwave Communications and BellSouth shall each execute a blanket letter of authorization with respect to customer requests so that prior proof of end-user authorization will not be necessary with every request (except in the case of a local service freeze). The Parties shall each be entitled to adopt their own internal processes for verification of customer authorization for requests, provided, however, that such processes shall comply with applicable state and federal law and industry and regulatory guidelines. Pursuant to a request from another carrier, BellSouth may disconnect any network element being used by Clearwave Communications to provide service to that End User and may reuse such network elements or facilities to enable such other carrier to provide service to the End User. BellSouth will notify Clearwave Communications that such a request has been processed but will

not be required to notify Clearwave Communications in advance of such processing.

- 3.2.1 Neither BellSouth nor Clearwave Communications shall prevent or delay an end-user from migrating to another carrier because of unpaid bills, denied service, or contract terms.
- 3.2.2 BellSouth shall provide access to customer service records (CSRs), Firm Order Confirmations (FOCs) and Local Service Request (LSR) rejects within the intervals set forth in Attachment 9 of this Agreement.
- 3.2.3 Clearwave Communications shall return a FOC to BellSouth within thirty-six (36) hours after Clearwave Communications's receipt from BellSouth of a valid LSR.
- 3.2.4 Clearwave Communications shall provide a Reject Response to BellSouth within twenty-four (24) hours after BellSouth's submission of an LSR which is incomplete or incorrectly formatted.
- 3.3 Use of Facilities. When a customer of Clearwave Communications elects to discontinue service and to transfer service to another local exchange carrier, including BellSouth, BellSouth shall have the right to reuse the facilities provided to Clearwave Communications by BellSouth. In addition, where BellSouth provides local switching, BellSouth may disconnect and reuse facilities when the facility is in a denied state and BellSouth has received a request to establish new service or transfer of service from a customer or a customer's CLEC at the same address served by the denied facility. BellSouth will notify Clearwave Communications that such a request has been processed after the disconnect order has been completed.
- 3.4 Contact Numbers. The Parties agree to provide one another with toll-free nationwide (50 states) contact numbers for the purpose of ordering, provisioning and maintenance of services.
- 3.5 Subscription Functions. In cases where BellSouth performs subscription functions for an interexchange carrier (IXC) (i.e. PIC and LPIC changes via Customer Account Record Exchange (CARE)), BellSouth will provide the affected IXCs with the Operating Company Number (OCN) of the local provider for the purpose of obtaining end user billing account and other end user information required under subscription requirements.
- 3.6 Cancellation Charges. If Clearwave Communications cancels a request for network elements or resold services, any costs incurred by BellSouth in conjunction with the provisioning of that request will be recovered in accordance with BellSouth's Private Line Tariff or BellSouth's FCC No. 1 Tariff, Section 5.4, as applicable. Notwithstanding the foregoing, if Clearwave Communications places an LSR based upon BellSouth's loop makeup information, and such information is inaccurate resulting in the inability of BellSouth to provision the network elements requested and another spare compatible facility cannot be found

with the transmission characteristics of the network elements originally requested, cancellation charges described in this Section shall not apply. Where Clearwave Communications places a single LSR for multiple network elements or services based upon loop makeup information, and information as to some, but not all, of the network elements or services is inaccurate, if BellSouth cannot provision the network elements or services that were the subject of the inaccurate loop makeup information, Clearwave Communications may cancel its request for those network elements or services without incurring cancellation charges as described in this Section. In such instance, should Clearwave Communications elect to cancel the entire LSR, cancellation charges as described in this Section shall apply to those elements and services that were not the subject of inaccurate loop makeup.

- 3.7 Service Date Advancement Charges (a.k.a. Expedites). For Service Date Advancement requests by Clearwave Communications, Service Date Advancement charges will apply for intervals less than the standard interval as outlined in the BellSouth Product and Services Interval Guide. The charges as outlined in BellSouth's FCC No. 1 Tariff, Section 5, will apply as applicable.

**Attachment 7**

**Billing**

**TABLE OF CONTENTS**

**1. PAYMENT AND BILLING ARRANGEMENTS..... 3**

**2. BILLING DISPUTES..... 7**

**3. RAO HOSTING..... 8**

**4. OPTIONAL DAILY USAGE FILE ..... 11**

**5. ACCESS DAILY USAGE FILE ..... 14**

**6. ENHANCED OPTIONAL DAILY USAGE FILE (EODUF) ..... 17**

**Rates.....Exhibit A**

## BILLING

### 1. PAYMENT AND BILLING ARRANGEMENTS

The terms and conditions set forth in this Attachment shall apply to all services ordered and provisioned pursuant to this Agreement.

- 1.1 **Billing.** BellSouth will bill through the Carrier Access Billing System (CABS), Integrated Billing System (IBS) and/or the Customer Records Information System (CRIS) depending on the particular service(s) provided to Clearwave Communications under this Agreement. BellSouth will format all bills in Carrier Billing Output Specification (CBOS) Standard or CLUB/EDI format, depending on the type of service provided. For those services where standards have not yet been developed, BellSouth's billing format will change as necessary when standards are finalized by the applicable industry forum.
  - 1.1.1 For any service(s) BellSouth receives from Clearwave Communications, Clearwave Communications shall bill BellSouth in CBOS format.
  - 1.1.2 Any switched access charges associated with interexchange carrier access to the resold local exchange lines will be billed by, and due to BellSouth.
  - 1.1.3 BellSouth will render bills each month on established bill days for each of Clearwave Communications's accounts. If either Party requests multiple billing media or additional copies of the bills, the billing Party will provide these at a reasonable cost.
  - 1.1.4 BellSouth will bill Clearwave Communications in advance for all services to be provided during the ensuing billing period except charges associated with service usage and nonrecurring charges, which will be billed in arrears.
    - 1.1.4.1 Charges for services will be calculated on an individual End User account level, including, if applicable, any charge for usage or usage allowances. BellSouth will also bill Clearwave Communications, and Clearwave Communications will be responsible for and remit to BellSouth, all charges applicable to said services including but not limited to 911 and E911 charges, End Users common line charges, federal subscriber line charges, telecommunications relay charges (TRS), and franchise fees, unless otherwise ordered by a Commission.
  - 1.1.5 BellSouth will not perform billing and collection services for Clearwave Communications as a result of the execution of this Agreement.
  - 1.1.6 In the event that this Agreement or an amendment to this Agreement effects a rate change to recurring rate elements that are billed in advance, BellSouth will make an adjustment to such recurring rates billed in advance at the previously effective rate. The adjustment shall reflect billing at the new rates from the Effective Date of the Agreement or amendment.

- 1.2 Establishing Accounts. After submitting a credit profile and deposit, if required, and after receiving certification as a local exchange carrier from the appropriate regulatory agency, Clearwave Communications will provide the appropriate BellSouth advisory team/local contract manager the necessary documentation to enable BellSouth to establish accounts for Local Interconnection, Network Elements and Other Services, Collocation and/or resold services. Such documentation shall include the Application for Master Account, if applicable, proof of authority to provide telecommunications services, the appropriate Operating Company Numbers (OCN) for each state as assigned by the National Exchange Carriers Association (NECA), Carrier Identification Code (CIC), Access Customer Name and Abbreviation (ACNA), Blanket Letter of Authorization (LOA), Misdirected Number form, and a tax exemption certificate, if applicable. Notwithstanding anything to the contrary in this Agreement, Clearwave Communications may not order services under a new account established in accordance with this Section 1.2 until 30 days after all information specified in this Section 1.2 is received from Clearwave Communications.
- 1.2.1 OCN. If Clearwave Communications needs to change its OCN(s) under which it operates when Clearwave Communications has already been conducting business utilizing those OCN(s), Clearwave Communications shall bear all costs incurred by BellSouth to convert Clearwave Communications to the new OCN(s). OCN conversion charges include all time required to make system updates to all of Clearwave Communications's End User customer records and will be handled by the BFR/NBR process.
- 1.2.2 Payment Responsibility. Payment of all charges will be the responsibility of Clearwave Communications. Clearwave Communications shall make payment to BellSouth for all services billed. Payments made by Clearwave Communications to BellSouth as payment on account will be credited to Clearwave Communications's accounts receivable master account. BellSouth will not become involved in billing disputes that may arise between Clearwave Communications and Clearwave Communications's customer.
- 1.3 Payment Due. Payment for services provided is due on or before the next bill date in immediately available funds. Payment is considered to have been made when received by BellSouth.
- 1.4 Due Dates. If the payment due date falls on a Sunday or on a holiday that is observed on a Monday, the payment due date shall be the first non-holiday day following such Sunday or holiday. If the payment due date falls on a Saturday or on a holiday which is observed on Tuesday, Wednesday, Thursday, or Friday, the payment due date shall be the last non-holiday day preceding such Saturday or holiday. If payment is not received by the payment due date, a late payment charge, as set forth in Section 1.6, below, shall apply.



- 1.5 Tax Exemption. Upon BellSouth's receipt of tax exemption certificate, the total amount billed to Clearwave Communications will not include those taxes or fees from which Clearwave Communications is exempt. Clearwave Communications will be solely responsible for the computation, tracking, reporting and payment of all taxes and like fees associated with the services provided to the End User of Clearwave Communications.
- 1.6 Late Payment. If any portion of the payment is not received by BellSouth on or before the payment due date as set forth preceding, or if any portion of the payment is received by BellSouth in funds that are not immediately available to BellSouth, then a late payment charge shall be due to BellSouth. The late payment charge shall be the portion of the payment not received by the payment due date multiplied by a late factor and will be applied on a per bill basis. The late factor shall be as set forth in Section A2 of the General Subscriber Services Tariff, Section B2 of the Private Line Service Tariff or Section E2 of the Intrastate Access Tariff, as appropriate. In addition to any applicable late payment charges, Clearwave Communications may be charged a fee for all returned checks as set forth in Section A2 of the General Subscriber Services Tariff or pursuant to the applicable state law.
- 1.7 Discontinuing Service to Clearwave Communications. The procedures for discontinuing service to Clearwave Communications are as follows:
- 1.7.1 BellSouth reserves the right to suspend or terminate service in the event of prohibited, unlawful or improper use of BellSouth facilities or service, abuse of BellSouth facilities, or any other violation or noncompliance by Clearwave Communications of the rules and regulations of BellSouth's tariffs.
- 1.7.2 BellSouth reserves the right to suspend or terminate service for nonpayment. If payment of amounts not subject to a billing dispute, as described in Section 2, is not received by the bill date in the month after the original bill date, BellSouth will provide written notice to Clearwave Communications that additional applications for service may be refused, that any pending orders for service may not be completed, and/or that access to ordering systems may be suspended if payment of such amounts, and all other amounts not in dispute that become past due before refusal, incompleteness or suspension, is not received by the fifteenth day following the date of the notice. In addition, BellSouth may, at the same time, provide written notice to the person designated by Clearwave Communications to receive notices of noncompliance that BellSouth may discontinue the provision of existing services to Clearwave Communications if payment of such amounts, and all other amounts not in dispute that become past due before discontinuance, is not received by the thirtieth day following the date of the initial notice.
- 1.7.3 In the case of discontinuance of services, all billed charges, as well as applicable termination charges, shall become due.

- 1.7.4 Discontinuance of service on Clearwave Communications's account will effect a discontinuance of service to Clearwave Communications's End Users. BellSouth will reestablish service for Clearwave Communications upon payment of all past due charges and the appropriate connection fee subject to BellSouth's normal application procedures. Clearwave Communications is solely responsible for notifying the End User of the discontinuance of the service. If within fifteen (15) days after Clearwave Communications's service has been discontinued and no arrangements to reestablish service have been made consistent with this subsection, Clearwave Communications's service will be disconnected.
- 1.8 Deposit Policy. Clearwave Communications shall complete the BellSouth Credit Profile and provide information to BellSouth regarding credit worthiness. Based on the results of the credit analysis, BellSouth reserves the right to secure the account with a suitable form of security deposit. Such security deposit shall take the form of cash, an Irrevocable Letter of Credit (BellSouth form), Surety Bond (BellSouth form) or, in BellSouth's sole discretion, some other form of security proposed by Clearwave Communications. Any such security deposit shall in no way release Clearwave Communications from its obligation to make complete and timely payments of its bill. Clearwave Communications shall pay any applicable deposits prior to the inauguration of service. If, in the sole opinion of BellSouth, circumstances so warrant and/or gross monthly billing has increased beyond the level initially used to determine the level of security deposit, BellSouth reserves the right to request additional security and/or file a Uniform Commercial Code (UCC-1) security interest in Clearwave Communications's "accounts receivables and proceeds." Interest on a security deposit, if provided in cash, shall accrue and be paid in accordance with the terms in the appropriate BellSouth tariff. Security deposits collected under this Section shall not exceed two months' estimated billing. In the event Clearwave Communications fails to remit to BellSouth any deposit requested pursuant to this Section, service to Clearwave Communications may be terminated in accordance with the terms of Section 1.7 of this Attachment, and any security deposits will be applied to Clearwave Communications's account(s). In the event Clearwave Communications defaults on its account, service to Clearwave Communications will be terminated in accordance with the terms of Section 1.7 above, and any security deposits will be applied to Clearwave Communications's account.
- 1.9 Notices. Notwithstanding anything to the contrary in this Agreement, all bills and notices regarding billing matters, including notices relating to security deposits, disconnection of services for nonpayment of charges, and rejection of additional orders from Clearwave Communications, shall be forwarded to the individual and/or address provided by Clearwave Communications in establishment of its billing account(s) with BellSouth, or to the individual and/or address subsequently provided by Clearwave Communications as the contact for billing information. All monthly bills and notices described in this Section shall be forwarded to the same individual and/or address; provided, however, upon written request from Clearwave Communications to BellSouth's billing organization, the notice of

discontinuance of services purchased by Clearwave Communications under this Agreement provided for in Section 1.7.2 of this Attachment shall be sent via certified mail to the individual(s) listed in the Notices provision of the General Terms and Conditions of this Agreement.

- 1.10 Rates. Rates for Optional Daily Usage File (ODUF), Access Daily Usage File (ADUF), Enhanced Optional Daily Usage File (EODUF) and Centralized Message Distribution Service (CMDS) are set out in Exhibit A to this Attachment. If no rate is identified in this Attachment, the rate for the specific service or function will be as set forth in the applicable BellSouth tariff or as negotiated by the Parties upon request by either Party.

## **2. BILLING DISPUTES**

- 2.1 Each Party agrees to notify the other Party in writing upon the discovery of a billing dispute. Clearwave Communications shall report all billing disputes to BellSouth using the Billing Adjustment Request Form (RF 1461) provided by BellSouth. In the event of a billing dispute, the Parties will endeavor to resolve the dispute within sixty (60) calendar days of the notification date. If the Parties are unable within the 60 day period to reach resolution, then the aggrieved Party may pursue dispute resolution in accordance with the General Terms and Conditions of this Agreement.

- 2.2 For purposes of this Section 2, a billing dispute means a reported dispute of a specific amount of money actually billed by either Party. The dispute must be clearly explained by the disputing Party and supported by written documentation, which clearly shows the basis for disputing charges. A billing dispute will not include the refusal to pay all or part of a bill or bills when no written documentation is provided to support the dispute, nor shall a billing dispute include the refusal to pay other amounts owed by the billed Party until the dispute is resolved. Claims by the billed Party for damages of any kind will not be considered a billing dispute for purposes of this Section. If the billing dispute is resolved in favor of the billing Party, the disputing Party will make immediate payment of any of the disputed amount owed to the billing Party or the billing Party shall have the right to pursue normal treatment procedures. Any credits due to the disputing Party, pursuant to the billing dispute, will be applied to the disputing Party's account by the billing Party immediately upon resolution of the dispute.

- 2.3 If a Party disputes a charge and does not pay such charge by the payment due date, or if a payment or any portion of a payment is received by either Party after the payment due date, or if a payment or any portion of a payment is received in funds which are not immediately available to the other Party, then a late payment charge and interest, where applicable, shall be assessed. For bills rendered by either Party for payment, the late payment charge for both Parties shall be calculated based on the portion of the payment not received by the payment due date multiplied by the

late factor as set forth in the following BellSouth tariffs: for services purchased from the General Subscribers Services Tariff for purposes of resale and for ports and non-designed loops, Section A2 of the General Subscriber Services Tariff; for services purchased from the Private Line Tariff for purposes of resale, Section B2 of the Private Line Service Tariff; and for designed network elements and other services and local interconnection charges, Section E2 of the Access Service Tariff. The Parties shall assess interest on previously assessed late payment charges only in a state where it has the authority pursuant to its tariffs.

### **3. RAO HOSTING**

- 3.1 RAO Hosting, Calling Card and Third Number Settlement System (CATS) and Non-Intercompany Settlement System (NICS) services provided to Clearwave Communications by BellSouth will be in accordance with the methods and practices regularly applied by BellSouth to its own operations during the term of this Agreement, including such revisions as may be made from time to time by BellSouth.
- 3.2 Clearwave Communications shall furnish all relevant information required by BellSouth for the provision of RAO Hosting, CATS and NICS.
- 3.3 Charges or credits, as applicable, will be applied by BellSouth to Clearwave Communications on a monthly basis in arrears. Amounts due (excluding adjustments) are payable within thirty (30) days of receipt of the billing statement.
- 3.4 Clearwave Communications must have its own unique hosted RAO code. Where BellSouth is the selected CMDS interfacing host, Clearwave Communications must request that BellSouth establish a unique hosted RAO code for Clearwave Communications. Such request shall be in writing to the BellSouth RAO Hosting coordinator and must be submitted at least eight (8) weeks prior to provision of services pursuant to this Section. Services shall commence on a date mutually agreed by the Parties.
- 3.5 BellSouth will receive messages from Clearwave Communications that are to be processed by BellSouth, another LEC in the BellSouth region or a LEC outside the BellSouth region. Clearwave Communications shall send all messages to BellSouth no later than sixty (60) days after the message date.
- 3.6 BellSouth will perform invoice sequence checking, standard EMI format editing, and balancing of message data with the EMI trailer record counts on all data received from Clearwave Communications.
- 3.7 All data received from Clearwave Communications that is to be processed or billed by another LEC within the BellSouth region will be distributed to that LEC in accordance with the Agreement(s) in effect between BellSouth and the involved LEC.

- 3.8 All data received from Clearwave Communications that is to be placed on the CMDS network for distribution outside the BellSouth region will be handled in accordance with the agreement(s) in effect between BellSouth and its connecting contractor.
- 3.9 BellSouth will receive messages from the CMDS network that are destined to be processed by Clearwave Communications and will forward them to Clearwave Communications on a daily basis for processing.
- 3.10 Transmission of message data between BellSouth and Clearwave Communications will be via CONNECT:Direct or Secure File Transfer Protocol (FTP).
- 3.10.1 Data circuits (private line or dial-up) will be required between BellSouth and Clearwave Communications for the purpose of data transmission when utilizing CONNECT:Direct. Where a dedicated line is required, Clearwave Communications will be responsible for ordering the circuit and coordinating the installation with BellSouth. Clearwave Communications is responsible for any charges associated with this line. Equipment required on the BellSouth end to attach the line to the mainframe computer and to transmit data will be negotiated on an individual case basis. Where a dial-up facility is required, dial circuits will be installed in the BellSouth data center by BellSouth and the associated charges assessed to Clearwave Communications. Additionally, all message toll charges associated with the use of the dial circuit by Clearwave Communications will be the responsibility of Clearwave Communications. Associated equipment on the BellSouth end, including a modem, will be negotiated on an individual case basis between the Parties. All equipment, including modems and software, that is required on the Clearwave Communications end for the purpose of data transmission will be the responsibility of Clearwave Communications.
- 3.10.2 If Clearwave Communications utilizes Secure File Transfer Protocol for data file transmission, purchase of the Secure File Transfer Protocol software will be the responsibility of Clearwave Communications.
- 3.11 All messages and related data exchanged between BellSouth and Clearwave Communications will be formatted for EMI formatted records and packed between appropriate EMI header and trailer records in accordance with accepted industry standards.
- 3.12 Clearwave Communications will maintain recorded message detail necessary to recreate files provided to BellSouth for a period of three (3) calendar months beyond the related message dates.
- 3.13 Should it become necessary for Clearwave Communications to send data to BellSouth more than sixty (60) days past the message date(s), Clearwave Communications will notify BellSouth in advance of the transmission of the data.

BellSouth will work with its connecting contractor and/or Clearwave Communications, where necessary, to notify all affected LECs.

- 3.14 In the event that data to be exchanged between the two Parties should become lost or destroyed, the Party responsible for creating the data will make every effort to restore and retransmit such data. If the data cannot be retrieved, the Party responsible for losing or destroying the data will be liable to the other Party for any resulting lost revenue. Lost revenue may be a combination of revenues that could not be billed to the End Users and associated access revenues. Both Parties will work together to estimate the revenue amount based upon historical data through a method mutually agreed upon. The resulting estimated revenue loss will be paid by the responsible Party to the other Party within three (3) calendar months of the resolution of the amount owed, or as mutually agreed upon by the Parties.
- 3.15 Should an error be detected by the EMI format edits performed by BellSouth on data received from Clearwave Communications, the entire pack containing the affected data will not be processed by BellSouth. BellSouth will notify Clearwave Communications of the error. Clearwave Communications will correct the error(s) and will resend the entire pack to BellSouth for processing. In the event that an out-of-sequence condition occurs on subsequent packs, Clearwave Communications will resend these packs to BellSouth after the pack containing the error has been successfully reprocessed by BellSouth.
- 3.16 In association with message distribution service, BellSouth will provide Clearwave Communications with associated intercompany settlements reports (CATS and NICS) as appropriate.
- 3.17 Notwithstanding anything in this Agreement to the contrary, in no case shall either Party be liable to the other for any direct or consequential damages incurred as a result of the obligations set out in this Section 3.
- 3.18 Intercompany Settlements Messages
- 3.18.1 Intercompany Settlements Messages facilitate the settlement of revenues associated with traffic originated from or billed by Clearwave Communications as a facilities based provider of local exchange telecommunications services outside the BellSouth region. Only traffic that originates in one Bell operating territory and bills in another Bell operating territory is included. Traffic that originates and bills within the same Bell operating territory will be settled on a local basis between Clearwave Communications and the involved company(ies), unless that company is participating in NICS.
- 3.18.2 Both traffic that originates outside the BellSouth region by Clearwave Communications and is billed within the BellSouth region, and traffic that originates within the BellSouth region and is billed outside the BellSouth region by Clearwave Communications, is covered by CATS. Also covered is traffic that

either is originated by or billed by Clearwave Communications, involves a company other than Clearwave Communications, qualifies for inclusion in the CATS settlement, and is not originated or billed within the BellSouth region (NICS).

- 3.18.3 Once Clearwave Communications is operating within the BellSouth territory, revenues associated with calls originated and billed within the BellSouth region will be settled via NICS.
- 3.18.4 BellSouth will receive the monthly NICS reports from Telcordia on behalf of Clearwave Communications. BellSouth will distribute copies of these reports to Clearwave Communications on a monthly basis.
- 3.18.5 BellSouth will receive the monthly CATS reports from Telcordia on behalf of Clearwave Communications. BellSouth will distribute copies of these reports to Clearwave Communications on a monthly basis.
- 3.18.6 BellSouth will collect the revenue earned by Clearwave Communications from the Bell operating company in whose territory the messages are billed via CATS, less a per message billing and collection fee of five cents (\$0.05), on behalf of Clearwave Communications. BellSouth will remit the revenue billed by Clearwave Communications to the Bell operating company in whose territory the messages originated, less a per message billing and collection fee of five cents (\$0.05), on behalf on Clearwave Communications. These two amounts will be netted together by BellSouth and the resulting charge or credit issued to Clearwave Communications via a monthly Carrier Access Billing System (CABS) miscellaneous bill.
- 3.18.7 BellSouth will collect the revenue earned by Clearwave Communications within the BellSouth territory from another CLEC also within the BellSouth territory (NICS) where the messages are billed, less a per message billing and collection fee of five cents (\$0.05), on behalf of Clearwave Communications. BellSouth will remit the revenue billed by Clearwave Communications within the BellSouth region to the CLEC also within the BellSouth region, where the messages originated, less a per message billing and collection fee of five cents (\$0.05). These two amounts will be netted together by BellSouth and the resulting charge or credit issued to Clearwave Communications via a monthly CABS miscellaneous bill.
- 3.18.8 BellSouth and Clearwave Communications agree that monthly netted amounts of less than fifty dollars (\$50.00) will not be settled.

**4. OPTIONAL DAILY USAGE FILE**

- 4.1 Upon written request from Clearwave Communications, BellSouth will provide the Optional Daily Usage File (ODUF) service to Clearwave Communications pursuant to the terms and conditions set forth in this section.
- 4.2 Clearwave Communications shall furnish all relevant information required by BellSouth for the provision of the ODUF.
- 4.3 The ODUF feed will contain billable messages that were carried over the BellSouth Network and processed in the BellSouth Billing System, but billed to a Clearwave Communications customer.
- 4.4 Charges for the ODUF will appear on Clearwave Communications' monthly bills for the previous month's usage. The charges are as set forth in Exhibit A to this Attachment. Clearwave Communications will be billed at the ODUF rates that are in effect at the end of the previous month.
- 4.5 The ODUF feed will contain both rated and unrated messages. All messages will be in the standard Alliance for Telecommunications Industry Solutions (ATIS) EMI record format.
- 4.6 Messages that error in the billing system of Clearwave Communications will be the responsibility of Clearwave Communications. If, however, Clearwave Communications should encounter significant volumes of errored messages that prevent processing by Clearwave Communications within its systems, BellSouth will work with Clearwave Communications to determine the source of the errors and the appropriate resolution.
- 4.7 The following specifications shall apply to the ODUF feed.
  - 4.7.1 ODUF Messages to be Transmitted
    - 4.7.1.1 The following messages recorded by BellSouth will be transmitted to Clearwave Communications:
      - 4.7.1.1.1 Message recording for per use/per activation type services (examples:  
Three -Way Calling, Verify, Interrupt, Call Return, etc.)
      - 4.7.1.1.2 Measured billable Local
      - 4.7.1.1.3 Directory Assistance messages
      - 4.7.1.1.4 IntraLATA Toll
      - 4.7.1.1.5 WATS and 800 Service
      - 4.7.1.1.6 N11
      - 4.7.1.1.7 Information Service Provider Messages



- 4.7.1.1.8 Operator Services Messages
- 4.7.1.1.9 Operator Services Message Attempted Calls (Network Element only)
- 4.7.1.1.10 Credit/Cancel Records
- 4.7.1.1.11 Usage for Voice Mail Message Service
- 4.7.1.2 Rated Incollects (messages BellSouth receives from other revenue accounting offices) can also be on ODUF. Rated Incollects will be intermingled with BellSouth recorded rated and unrated usage. Rated Incollects will not be packed separately.
- 4.7.1.3 BellSouth will perform duplicate record checks on records processed to ODUF. Any duplicate messages detected will be deleted and not sent to Clearwave Communications.
- 4.7.1.4 In the event that Clearwave Communications detects a duplicate on ODUF they receive from BellSouth, Clearwave Communications will drop the duplicate message and will not return the duplicate to BellSouth.
- 4.7.2 ODUF Physical File Characteristics
  - 4.7.2.1 ODUF will be distributed to Clearwave Communications via CONNECT:Direct, Secure File Transfer Protocol (FTP) or another mutually agreed medium. The ODUF feed will be a variable block format. The data on the ODUF feed will be in a non-compacted EMI format (175 byte format plus modules). It will be created on a daily basis Monday through Friday except holidays. Details such as dataset name and delivery schedule will be addressed during negotiations of the distribution medium. There will be a maximum of one dataset per workday per OCN.
  - 4.7.2.2 Data circuits (private line or dial-up) will be required between BellSouth and Clearwave Communications for the purpose of data transmission as set forth in Section 3.10.1 above.
  - 4.7.2.3 If Clearwave Communications utilizes Secure File Transfer Protocol (FTP) for data file transmission, purchase of the Secure File Transfer Protocol (FTP) software will be the responsibility of Clearwave Communications.
- 4.7.3 ODUF Packing Specifications
  - 4.7.3.1 A pack will contain a minimum of one message record or a maximum of 99,999 message records plus a pack header record and a pack trailer record. One transmission can contain a maximum of 99 packs and a minimum of one pack.

4.7.3.2 The OCN, From RAO, and Invoice Number will control the invoice sequencing. The From RAO will be used to identify to Clearwave Communications which BellSouth RAO that is sending the message. BellSouth and Clearwave Communications will use the invoice sequencing to control data exchange. BellSouth will be notified of sequence failures identified by Clearwave Communications and resend the data as appropriate.

The data will be packed using ATIS EMI records.

4.7.4 ODUF Pack Rejection

4.7.4.1 Clearwave Communications will notify BellSouth within one business day of rejected packs (via the mutually agreed medium). Packs could be rejected because of pack sequencing discrepancies or a critical edit failure on the Pack Header or Pack Trailer records (i.e. out-of-balance condition on grand totals, invalid data populated). Standard ATIS EMI error codes will be used. Clearwave Communications will not be required to return the actual rejected data to BellSouth. Rejected packs will be corrected and retransmitted to Clearwave Communications by BellSouth.

4.7.5 ODUF Control Data

4.7.5.1 Clearwave Communications will send one confirmation record per pack that is received from BellSouth. This confirmation record will indicate Clearwave Communications's receipt of the pack and acceptance or rejection of the pack. Pack Status Code(s) will be populated using standard ATIS EMI error codes for packs that were rejected by Clearwave Communications for reasons stated in the above section.

4.7.6 ODUF Testing

4.7.6.1 Upon request from Clearwave Communications, BellSouth shall send ODUF test files to Clearwave Communications. The Parties agree to review and discuss the ODUF content and/or format. For testing of usage results, BellSouth shall request that Clearwave Communications set up a production (live) file. The live test may consist of Clearwave Communications's employees making test calls for the types of services Clearwave Communications requests on ODUF. These test calls are logged by Clearwave Communications, and the logs are provided to BellSouth. These logs will be used to verify the files. Testing will be completed within 30 calendar days from the date on which the initial test file was sent.

## **5. ACCESS DAILY USAGE FILE**

5.1 Upon written request from Clearwave Communications, BellSouth will provide the Access Daily Usage File (ADUF) service to Clearwave Communications pursuant to the terms and conditions set forth in this section.

- 5.2 Clearwave Communications shall furnish all relevant information required by BellSouth for the provision of ADUF.
- 5.3 ADUF will contain access messages associated with a port that Clearwave Communications has purchased from BellSouth
- 5.4 Charges for ADUF will appear on Clearwave Communications's monthly bills for the previous month's usage. The charges are as set forth in Exhibit A to this Attachment. Clearwave Communications will be billed at the ADUF rates that are in effect at the end of the previous month.
- 5.5 Messages that error in the billing system of Clearwave Communications will be the responsibility of Clearwave Communications. If, however, Clearwave Communications should encounter significant volumes of errored messages that prevent processing by Clearwave Communications within its systems, BellSouth will work with Clearwave Communications to determine the source of the errors and the appropriate resolution.
- 5.6 ADUF Messages To Be Transmitted
  - 5.6.1 The following messages recorded by BellSouth will be transmitted to Clearwave Communications:
    - 5.6.1.1 Recorded originating and terminating interstate and intrastate access records associated with a port.
    - 5.6.1.2 Recorded terminating access records for undetermined jurisdiction access records associated with a port.
  - 5.6.2 BellSouth will perform duplicate record checks on records processed to ADUF. Any duplicate messages detected will be dropped and not sent to Clearwave Communications.
  - 5.6.3 In the event that Clearwave Communications detects a duplicate on ADUF they receive from BellSouth, Clearwave Communications will drop the duplicate message and will not return the duplicate to BellSouth.
  - 5.6.4 ADUF Physical File Characteristics
    - 5.6.4.1 ADUF will be distributed to Clearwave Communications via CONNECT:Direct, Secure File Transfer Protocol (FTP) or another mutually agreed medium. The ADUF feed will be a fixed block format. The data on the ADUF feed will be in a non-compacted EMI format (210 byte). It will be created on a daily basis Monday through Friday except holidays. Details such as dataset name and delivery schedule will be addressed during negotiations of the distribution medium. There will be a maximum of one dataset per workday per OCN.

- 5.6.4.2 Data circuits (private line or dial-up) will be required between BellSouth and Clearwave Communications for the purpose of data transmission as set forth in Section 3.10.1 above.
- 5.6.4.3 If Clearwave Communications utilizes Secure File Transfer Protocol (FTP) for data file transmission, purchase of the Secure File Transfer Protocol (FTP) software will be the responsibility of Clearwave Communications.
- 5.6.5 ADUF Packing Specifications
  - 5.6.5.1 A pack will contain a minimum of one message record or a maximum of 99,999 message records plus a pack header record and a pack trailer record. One transmission can contain a maximum of 99 packs and a minimum of one pack.
  - 5.6.5.2 The OCN, From RAO, and Invoice Number will control the invoice sequencing. The From RAO will be used to identify to Clearwave Communications which BellSouth RAO is sending the message. BellSouth and Clearwave Communications will use the invoice sequencing to control data exchange. BellSouth will be notified of sequence failures identified by Clearwave Communications and resend the data as appropriate.  
The data will be packed using ATIS EMI records.
- 5.6.6 ADUF Pack Rejection
  - 5.6.6.1 Clearwave Communications will notify BellSouth within one business day of rejected packs (via the mutually agreed medium). Packs could be rejected because of pack sequencing discrepancies or a critical edit failure on the Pack Header or Pack Trailer records (i.e. out-of-balance condition on grand totals, invalid data populated). Standard ATIS EMI error codes will be used. Clearwave Communications will not be required to return the actual rejected data to BellSouth. Rejected packs will be corrected and retransmitted to Clearwave Communications by BellSouth.
- 5.6.7 ADUF Control Data
  - 5.6.7.1 Clearwave Communications will send one confirmation record per pack that is received from BellSouth. This confirmation record will indicate Clearwave Communications's receipt of the pack and acceptance or rejection of the pack. Pack Status Code(s) will be populated using standard ATIS EMI error codes for packs that were rejected by Clearwave Communications for reasons stated in the above section.
- 5.6.8 ADUF Testing
  - 5.6.8.1 Upon request from Clearwave Communications, BellSouth shall send a test file of generic data to Clearwave Communications via Connect:Direct or Text File via E-Mail. The Parties agree to review and discuss the test file's content and/or format.

**6. ENHANCED OPTIONAL DAILY USAGE FILE (EODUF)**

- 6.1 Upon written request from Clearwave Communications, BellSouth will provide the Enhanced Optional Daily Usage File (EODUF) service to Clearwave Communications pursuant to the terms and conditions set forth in this section. EODUF will only be sent to existing ODUF subscribers who request the EODUF option.
- 6.2 Clearwave Communications shall furnish all relevant information required by BellSouth for the provision of the Enhanced Optional Daily Usage File.
- 6.3 The Enhanced Optional Daily Usage File (EODUF) will provide usage data for local calls originating from resold Flat Rate Business and Residential Lines.
- 6.4 Charges for delivery of the Enhanced Optional Daily Usage File will appear on Clearwave Communications's monthly bills for the previous month's usage. The charges are as set forth in Exhibit A to this Attachment. Clearwave Communications will be billed at the EODUF rates that are in effect at the end of the previous month.
- 6.5 All messages will be in the standard Alliance for Telecommunications Industry Solutions (ATIS) EMI record format.
- 6.6 Messages that error in the billing system of Clearwave Communications will be the responsibility of Clearwave Communications. If, however, Clearwave Communications should encounter significant volumes of errored messages that prevent processing by Clearwave Communications within its systems, BellSouth will work with Clearwave Communications to determine the source of the errors and the appropriate resolution.
- 6.7 The following specifications shall apply to the EODUF feed.
- 6.7.1 Usage To Be Transmitted
- 6.7.1.1 The following messages recorded by BellSouth will be transmitted to Clearwave Communications:
- 6.7.1.1.1 Customer usage data for flat rated local call originating from Clearwave Communications's End User lines (1FB or 1FR). The EODUF record for flat rate messages will include:
- 6.7.1.1.2 Date of Call
- 6.7.1.1.3 From Number
- 6.7.1.1.4 To Number

- 6.7.1.1.5 Connect Time
- 6.7.1.1.6 Conversation Time
- 6.7.1.1.7 Method of Recording
- 6.7.1.1.8 From RAO
- 6.7.1.1.9 Rate Class
- 6.7.1.1.10 Message Type
- 6.7.1.1.11 Billing Indicators
- 6.7.1.1.12 Bill to Number
- 6.7.1.2 BellSouth will perform duplicate record checks on EODUF records processed to Optional Daily Usage File. Any duplicate messages detected will be deleted and not sent to Clearwave Communications.
- 6.7.1.3 In the event that Clearwave Communications detects a duplicate on Enhanced Optional Daily Usage File they receive from BellSouth, Clearwave Communications will drop the duplicate message (Clearwave Communications will not return the duplicate to BellSouth).
- 6.7.2 Physical File Characteristics
  - 6.7.2.1 The EODUF feed will be distributed to Clearwave Communications over their existing Optional Daily Usage File (ODUF) feed. The EODUF messages will be intermingled among Clearwave Communications's Optional Daily Usage File (ODUF) messages. The EODUF will be a variable block format (2476) with an LRECL of 2472. The data on the EODUF will be in a non-compacted EMI format (175 byte format plus modules). It will be created on a daily basis (Monday through Friday except holidays).
  - 6.7.2.2 Data circuits (private line or dial-up) may be required between BellSouth and Clearwave Communications for the purpose of data transmission. Where a dedicated line is required, Clearwave Communications will be responsible for ordering the circuit, overseeing its installation and coordinating the installation with BellSouth. Clearwave Communications will also be responsible for any charges associated with this line. Equipment required on the BellSouth end to attach the line to the mainframe computer and to transmit successfully ongoing will be negotiated on an individual case basis. Where a dial-up facility is required, dial circuits will be installed in the BellSouth data center by BellSouth and the associated charges assessed to Clearwave Communications. Additionally, all message toll charges associated with the use of the dial circuit by Clearwave Communications will be the responsibility of Clearwave Communications.

Associated equipment on the BellSouth end, including a modem, will be negotiated on an individual case basis between the Parties. All equipment, including modems and software, that is required on Clearwave Communications's end for the purpose of data transmission will be the responsibility of Clearwave Communications.

6.7.3 Packing Specifications

6.7.3.1 A pack will contain a minimum of one message record or a maximum of 99,999 message records plus a pack header record and a pack trailer record. One transmission can contain a maximum of 99 packs and a minimum of one pack.

6.7.3.2 The Operating Company Number (OCN), From Revenue Accounting Office (RAO), and Invoice Number will control the invoice sequencing. The From RAO will be used to identify to Clearwave Communications which BellSouth RAO is sending the message. BellSouth and Clearwave Communications will use the invoice sequencing to control data exchange. BellSouth will be notified of sequence failures identified by Clearwave Communications and resend the data as appropriate.

6.7.3.3 The data will be packed using ATIS EMI records.

ODUF/ADUF/EODUF/CMDS - Kentucky										Attachment: 7		Exhibit: A			
CATEGORY	RATE ELEMENTS	Interim	Zone	BCS	USOC	RATES (\$)				Svc Order Submitted Elec per LSR	Svc Order Submitted Manually per LSR	Incremental Charge - Manual Svc Order vs. Electronic-1st	Incremental Charge - Manual Svc Order vs. Electronic-Add'l	Incremental Charge - Manual Svc Order vs. Electronic-Disc 1st	Incremental Charge - Manual Svc Order vs. Electronic-Disc Add'l
						Rec	Nonrecurring		Nonrecurring Disconnect						
							First	Add'l	First	Add'l	SOME C	SOMAN	SOMAN	SOMAN	SOMAN
<b>ODUF/ADUF/OEDUF/CMDS</b>															
<b>ACCESS DAILY USAGE FILE (ADUF)</b>															
	ADUF: Message Processing, per message				N/A	0.001857									
	ADUF: Data Transmission (CONNECT:DIRECT), per message				N/A	0.0001245									
<b>OPTIONAL DAILY USAGE FILE (ODUF)</b>															
	ODUF: Recording, per message				N/A	0.0000136									
	ODUF: Message Processing, per message				N/A	0.002506									
	ODUF: Message Processing, per Magnetic Tape provisioned				N/A	35.90									
	ODUF: Data Transmission (CONNECT:DIRECT), per message				N/A	0.00010372									
<b>CENTRALIZED MESSAGE DISTRIBUTION SERVICE (CMDS)</b>															
	CMDS: Message Processing, per message				N/A	0.004									
	CMDS: Data Transmission (CONNECT:DIRECT), per message				N/A	0.001									
<b>ENHANCED OPTIONAL DAILY USAGE FILE (EODUF)</b>															
	EODUF: Message Processing, per message				N/A	0.235889									
<b>Notes: If no rate is identified in the contract, the rate for the specific service or function will be as set forth in applicable BellSouth tariff or as negotiated by the Parties upon request by either Party.</b>															



## **Attachment 8**

### **Rights-of-Way, Conduits and Pole Attachments**

## **Rights-of-Way, Conduits and Pole Attachments**

BellSouth will provide nondiscriminatory access to any pole, duct, conduit, or right-of-way owned or controlled by BellSouth pursuant to 47 U.S.C. § 224, as amended by the Act, pursuant to terms and conditions of a license agreement subsequently negotiated with BellSouth's Competitive Structure Provisioning Center.

**Attachment 9**  
**Performance Measurements**

## **PERFORMANCE MEASUREMENTS**

Upon a particular Commission's issuance of an Order pertaining to Performance Measurements in a proceeding expressly applicable to all CLECs generally, BellSouth shall implement in that state such Performance Measurements as of the date specified by the Commission. Performance Measurements that have been Ordered in a particular state can currently be accessed via the internet at <https://pmap.bellsouth.com>.

**Attachment 10**

**BellSouth Disaster Recovery Plan**

<b><u>CONTENTS</u></b>		<b><u>PAGE</u></b>
1.0	Purpose	2
2.0	Single Point of Contact	2
3.0	Identifying the Problem	2
3.1	Site Control	3
3.2	Environmental Concerns	4
4.0	The Emergency Control Center (ECC)	4
5.0	Recovery Procedures	5
5.1	CLEC Outage	5
5.2	BellSouth Outage	5
5.2.1	Loss of Central Office	6
5.2.2	Loss of a Central Office with Serving Wire Center Functions	6
5.2.3	Loss of a Central Office with Tandem Functions	6
5.2.4	Loss of a Facility Hub	7
5.3	Combined Outage (CLEC and BellSouth Equipment)	7
6.0	T1 Identification Procedures	7
7.0	Acronyms	8

## **1.0 PURPOSE**

In the unlikely event of a disaster occurring that affects BellSouth's long-term ability to deliver traffic to a Competitive Local Exchange Carrier (CLEC), general procedures have been developed by BellSouth to hasten the recovery process in accordance with the Telecommunications Service Priority (TSP) Program established by the Federal Communications Commission to identify and prioritize telecommunication services that support national security or emergency preparedness (NS/EP) missions. Since each location is different and could be affected by an assortment of potential problems, a detailed recovery plan is impractical. However, in the process of reviewing recovery activities for specific locations, some basic procedures emerge that appear to be common in most cases.

These general procedures should apply to any disaster that affects the delivery of traffic for an extended time period. Each CLEC will be given the same consideration during an outage, and service will be restored as quickly as possible.

This document will cover the basic recovery procedures that would apply to every CLEC.

## **2.0 SINGLE POINT OF CONTACT**

When a problem is experienced, regardless of the severity, the BellSouth Network Management Center (NMC) will observe traffic anomalies and begin monitoring the situation. Controls will be appropriately applied to insure the sanity of BellSouth's network; and, in the event that a switch or facility node is lost, the NMC will attempt to circumvent the failure using available reroutes.

BellSouth's NMC will remain in control of the restoration efforts until the problem has been identified as being a long-term outage. At that time, the NMC will contact BellSouth's Emergency Control Center (ECC) and relinquish control of the recovery efforts. Even though the ECC may take charge of the situation, the NMC will continue to monitor the circumstances and restore traffic as soon as damaged network elements are revitalized.

**The telephone number for the BellSouth Network Management Center in Atlanta, as published in Telcordia's National Network Management Directory, is 404-321-2516.**

## **3.0 IDENTIFYING THE PROBLEM**

During the early stages of problem detection, the NMC will be able to tell which CLECs are affected by the catastrophe. Further analysis and/or first hand observation will determine if the disaster has affected CLEC equipment only, BellSouth equipment only or a combination. The initial restoration activity will be largely determined by the equipment that is affected.

Once the nature of the disaster is determined and after verifying the cause of the problem, the NMC will initiate reroutes and/or transfers that are jointly agreed upon by the affected CLECs' Network Management Center and the BellSouth NMC. The type and percentage of controls used will depend upon available network capacity. Controls necessary to stabilize the situation will be invoked and the NMC will attempt to re-establish as much traffic as possible.

For long-term outages, recovery efforts will be coordinated by the Emergency Control Center (ECC). Traffic controls will continue to be applied by the NMC until facilities are re-established. As equipment is made available for service, the ECC will instruct the NMC to begin removing the controls and allow traffic to resume.

### **3.1 SITE CONTROL**

In the total loss of building use scenario, what likely exists will be a smoking pile of rubble. This rubble will contain many components that could be dangerous. It could also contain any personnel on the premises at the time of the disaster. For these reasons, the local fire marshal with the assistance of the police will control the site until the building is no longer a threat to surrounding properties and the companies have secured the site from the general public.

During this time, the majority owner of the building should be arranging for a demolition contractor to mobilize to the site with the primary objective of reaching the cable entrance facility for a damage assessment. The results of this assessment would then dictate immediate plans for restoration, both short term and permanent.

In a less catastrophic event, i.e., the building is still standing and the cable entrance facility is usable, the situation is more complex. The site will initially be controlled by local authorities until the threat to adjacent property has diminished. Once the site is returned to the control of the companies, the following events should occur.

An initial assessment of the main building infrastructure systems (mechanical, electrical, fire and life safety, elevators, and others) will establish building needs. Once these needs are determined, the majority owner should lead the building restoration efforts. There may be situations where the site will not be totally restored within the confines of the building. The companies must individually determine their needs and jointly assess the cost of permanent restoration to determine the overall plan of action.

Multiple restoration trailers from each company will result in the need for designated space and installation order. This layout and control is required to maximize the amount of restoration equipment that can be placed at the site, and the priority of placements.

Care must be taken in this planning to ensure other restoration efforts have logistical access to the building. Major components of telephone and building equipment will need to be removed and replaced. A priority for this equipment must also be jointly established to facilitate overall site restoration. (Example: If the AC switchgear has sustained damage, this would be of the highest priority in order to regain power, lighting, and HVAC throughout the building.)

If the site will not accommodate the required restoration equipment, the companies would then need to quickly arrange with local authorities for street closures, rights of way or other possible options available.

### 3.2 ENVIRONMENTAL CONCERNS

In the worse case scenario, many environmental concerns must be addressed. Along with the police and fire marshal, the state environmental protection department will be on site to monitor the situation.

Items to be concerned with in a large central office building could include:

1. Emergency engine fuel supply. Damage to the standby equipment and the fuel handling equipment could have created "spill" conditions that have to be handled within state and federal regulations.
2. Asbestos-containing materials that may be spread throughout the wreckage. Asbestos could be in many components of building, electrical, mechanical, outside plant distribution, and telephone systems.
3. Lead and acid. These materials could be present in potentially large quantities depending upon the extent of damage to the power room.
4. Mercury and other regulated compounds resident in telephone equipment.
5. Other compounds produced by the fire or heat.

Once a total loss event occurs at a large site, local authorities will control immediate clean up (water placed on the wreckage by the fire department) and site access.

At some point, the companies will become involved with local authorities in the overall planning associated with site clean up and restoration. Depending on the clean up approach taken, delays in the restoration of several hours to several days may occur.

In a less severe disaster, items listed above are more defined and can be addressed individually depending on the damage.

In each case, the majority owner should coordinate building and environmental restoration as well as maintain proper planning and site control.

### **4.0 THE EMERGENCY CONTROL CENTER (ECC)**

The ECC is located in the Midtown 1 Building in Atlanta, Georgia. During an emergency, the ECC staff will convene a group of pre-selected experts to inventory the damage and initiate corrective actions. These experts have regional access to BellSouth's personnel and equipment and will assume control of the restoration activity anywhere in the nine-state area.

In the past, the ECC has been involved with restoration activities resulting from hurricanes, ice storms and floods. They have demonstrated their capabilities during these calamities as well as



during outages caused by human error or equipment failures. This group has an excellent record of restoring service as quickly as possible.

During a major disaster, the ECC may move emergency equipment to the affected location, direct recovery efforts of local personnel and coordinate service restoration activities with the CLECs. The ECC will attempt to restore service as quickly as possible using whatever means is available, leaving permanent solutions, such as the replacement of damaged buildings or equipment, for local personnel to administer.

Part of the ECC's responsibility, after temporary equipment is in place, is to support the NMC efforts to return service to the CLECs. Once service has been restored, the ECC will return control of the network to normal operational organizations. Any long-term changes required after service is restored will be made in an orderly fashion and will be conducted as normal activity.

## **5.0 RECOVERY PROCEDURES**

The nature and severity of any disaster will influence the recovery procedures. One crucial factor in determining how BellSouth will proceed with restoration is whether or not BellSouth's equipment is incapacitated. Regardless of whose equipment is out of service, BellSouth will move as quickly as possible to aid with service recovery; however, the approach that will be taken may differ depending upon the location of the problem.

### **5.1 CLEC OUTAGE**

For a problem limited to one CLEC (or a building with multiple CLECs), BellSouth has several options available for restoring service quickly. For those CLECs that have agreements with other CLECs, BellSouth can immediately start directing traffic to a provisional CLEC for completion. This alternative is dependent upon BellSouth having concurrence from the affected CLECs.

Whether or not the affected CLECs have requested a traffic transfer to another CLEC will not impact BellSouth's resolve to re-establish traffic to the original destination as quickly as possible.

### **5.2 BELLSOUTH OUTAGE**

Because BellSouth's equipment has varying degrees of impact on the service provided to the CLECs, restoring service from damaged BellSouth equipment is different. The outage will probably impact a number of Carriers simultaneously. However, the ECC will be able to initiate immediate actions to correct the problem.

A disaster involving any of BellSouth's equipment locations could impact the CLECs, some more than others. A disaster at a Central Office (CO) would only impact the delivery of traffic to and from that one location, but the incident could affect many Carriers. If the Central Office is a Serving Wire Center (SWC), then traffic from the entire area to those Carriers served from that switch would also be impacted. If the switch functions as an Access Tandem, or there is a tandem in the building, traffic from every CO to every CLEC could be interrupted. A disaster that destroys a facility hub could disrupt various traffic flows, even though the switching equipment may be unaffected.

The NMC would be the first group to observe a problem involving BellSouth's equipment. Shortly after a disaster, the NMC will begin applying controls and finding re-routes for the

completion of as much traffic as possible. These reroutes may involve delivering traffic to alternate Carriers upon receiving approval from the CLECs involved. In some cases, changes in translations will be required. If the outage is caused by the destruction of equipment, then the ECC will assume control of the restoration.

### **5.2.1 Loss of a Central Office**

When BellSouth loses a Central Office, the ECC will

- a) Place specialists and emergency equipment on notice;
- b) Inventory the damage to determine what equipment and/or functions are lost;
- c) Move containerized emergency equipment and facility equipment to the stricken area, if necessary;
- d) Begin reconnecting service on a parity basis for Hospitals, Police and other emergency agencies or End Users served by BellSouth or CLEC in accordance with the TSP priority restoration coding scheme entered in the BellSouth Maintenance database immediately prior to the emergency.

### **5.2.2 Loss of a Central Office with Serving Wire Center Functions**

The loss of a Central Office that also serves as a Serving Wire Center (SWC) will be restored as described in Section 5.2.1.

### **5.2.3 Loss of a Central Office with Tandem Functions**

When BellSouth loses a Central Office building that serves as an Access Tandem and as a SWC, the ECC will

- a) Place specialists and emergency equipment on notice;
- b) Inventory the damage to determine what equipment and/or functions are lost;
- c) Move containerized emergency equipment and facility equipment to the stricken area, if necessary;
- d) Begin reconnecting service on a parity basis for Hospitals, Police and other emergency agencies or End Users served by BellSouth or CLEC in accordance with the TSP priority restoration coding scheme entered in the BellSouth Maintenance database immediately prior to the emergency;
- e) Re-direct as much traffic as possible to the alternate access tandem (if available) for delivery to those CLECs utilizing a different location as a SWC;
- f) Begin aggregating traffic to a location near the damaged building. From this location, begin re-establishing trunk groups to the CLECs for the delivery of traffic normally found on the direct trunk groups. (This aggregation point may be the alternate access tandem location or another CO on a primary facility route.)

#### **5.2.4 Loss of a Facility Hub**

In the event that BellSouth loses a facility hub, the recovery process is much the same as above. Once the NMC has observed the problem and administered the appropriate controls, the ECC will assume authority for the repairs. The recovery effort will include

- a) Placing specialists and emergency equipment on notice;
- b) Inventorying the damage to determine what equipment and/or functions are lost;
- c) Moving containerized emergency equipment to the stricken area, if necessary;
- d) Reconnecting service on a parity basis for Hospitals, Police and other emergency agencies or End Users served by BellSouth or CLEC in accordance with the TSP priority restoration coding scheme entered in the BellSouth Maintenance database immediately prior to the emergency; and
- e) If necessary, BellSouth will aggregate the traffic at another location and build temporary facilities. This alternative would be viable for a location that is destroyed and building repairs are required.

#### **5.3 COMBINED OUTAGE (CLEC AND BELLSOUTH EQUIPMENT)**

In some instances, a disaster may impact BellSouth's equipment as well as the CLECs'. This situation will be handled in much the same way as described in Section 5.2.3. Since BellSouth and the CLECs will be utilizing temporary equipment, close coordination will be required.

#### **6.0 T1 IDENTIFICATION PROCEDURES**

During the restoration of service after a disaster, BellSouth may be forced to aggregate traffic for delivery to a CLEC. During this process, T1 traffic may be consolidated onto DS3s and may become unidentifiable to the Carrier. Because resources will be limited, BellSouth may be forced to "package" this traffic entirely differently than normally received by the CLECs. Therefore, a method for identifying the T1 traffic on the DS3s and providing the information to the Carriers is required.

## 7.0 ACRONYMS

CLEC	-	Competitive Local Exchange Carrier
CO	-	Central Office (BellSouth)
DS3	-	Facility that carries 28 T1s (672 circuits)
ECC	-	Emergency Control Center (BellSouth)
NMC	-	Network Management Center
SWC	-	Serving Wire Center (BellSouth switch)
T1	-	Facility that carries 24 circuits
TSP	-	Telecommunications Service Priority

### **Hurricane Information**

During a hurricane, BellSouth will make every effort to keep CLECs updated on the status of our network. Information centers will be set up throughout BellSouth Telecommunications. These centers are not intended to be used for escalations, but rather to keep the CLEC informed of network related issues, area damages and dispatch conditions, etc.

Hurricane-related information can also be found on line at [http://www.interconnection.bellsouth.com/network/disaster/dis\\_resp.htm](http://www.interconnection.bellsouth.com/network/disaster/dis_resp.htm). Information concerning Mechanized Disaster Reports can also be found at this website by clicking on CURRENT MDR REPORTS or by going directly to <http://www.interconnection.bellsouth.com/network/disaster/mdrs.htm>.

### **BST Disaster Management Plan**

BellSouth maintenance centers have geographical and redundant communication capabilities. In the event of a disaster removing any maintenance center from service another geographical center would assume maintenance responsibilities. The contact numbers will not change and the transfer will be transparent to the CLEC.

## **Attachment 11**

### **Bona Fide Request and New Business Request Process**

## **BONA FIDE REQUEST AND NEW BUSINESS REQUEST PROCESS**

1.0 The Parties agree that Clearwave Communications is entitled to order any Unbundled Network Element, Interconnection option, service option or Resale Service required to be made available by FCC or Commission requirements pursuant to the Communications Act of 1934, as modified by the Telecommunications Act of 1996 (the "Act"). Clearwave Communications also shall be permitted to request the development of new or revised facilities or service options which are not required by the Act. Procedures applicable to requesting the addition of such facilities or service options are specified in this Attachment 11.

### **2.0 BONA FIDE REQUEST**

2.1 A Bona Fide Request (BFR) is to be used when Clearwave Communications makes a request of BellSouth to provide a new or modified Unbundled Network Element, Interconnection option, or other service option (Requested Services) pursuant to the Act that was not previously included in this Agreement.

2.2 A BFR shall be submitted in writing by Clearwave Communications and shall specifically identify the requested service date, technical requirements, space requirements and/or such other specifications that clearly define the request such that BellSouth has sufficient information to analyze and prepare a response. Such a request shall also include Clearwave Communications's designation of the request as being pursuant to the Telecommunications Act of 1996 (i.e. a BFR). The request shall be sent to Clearwave Communications's designated BellSouth Sales contact.

2.3 If BellSouth determines that the preliminary analysis of the requested BFR is of such complexity that it will cause BellSouth to expend inordinate resources to evaluate the BFR, BellSouth shall notify Clearwave Communications within ten (10) business days of BellSouth's receipt of BFR that a fee will be required prior to the evaluation of the BFR. Clearwave Communications shall submit such fee within thirty (30) business days of BellSouth's notice that a fee is required. Within thirty (30) business days of BellSouth's receipt of the fee, BellSouth shall respond to Clearwave Communications by providing a preliminary analysis of such Requested Services that are the subject of the BFR. The preliminary analysis shall either confirm that BellSouth will offer access to the Requested Services or confirm that BellSouth will not offer the Requested Services. If the preliminary analysis states that BellSouth will

not offer the Requested Services, BellSouth will provide an explanation of why the request is not technically feasible, does not qualify as a BFR for the Requested Services or is otherwise not required to be provided under the Act. If preliminary analysis of the requested BFR is not of such complexity that it will cause BellSouth to expend inordinate resources to evaluate the BFR, within thirty (30) business days of its receipt of the BFR, BellSouth shall respond to Clearwave Communications by providing a preliminary analysis of such Requested Services that are the subject of the BFR. The preliminary analysis shall either confirm that BellSouth will offer access to the Requested Services or confirm that BellSouth will not offer the Requested Services. If the preliminary analysis states that BellSouth will not offer the Requested Services, BellSouth will provide an explanation of why the request is not technically feasible, does not qualify as a BFR for the Requested Services or is otherwise not required to be provided under the Act.

- 2.4 Clearwave Communications may cancel a BFR at any time. If Clearwave Communications cancels the request more than ten (10) business days after submitting the BFR request, Clearwave Communications shall pay BellSouth's reasonable and demonstrable costs of processing and/or implementing the BFR up to the date of cancellation in addition to any fee submitted in accordance with Section 2.3 above.
- 2.5 Clearwave Communications will have thirty (30) business days from receipt of preliminary analysis to accept the preliminary analysis or cancel the BFR as set forth in Section 2.4. Acceptance of the preliminary analysis must be in writing and accompanied by all nonrecurring charges quoted in the preliminary analysis. The nonrecurring charges as stated in the preliminary analysis cover the initial work required to develop the project plan, create the design parameters, and establish all activities and resources required to complete the BFR (Development Costs). Development costs are non-refundable. If Clearwave Communications fails to respond within this 30-day period, the BFR will be deemed cancelled.
- 2.5.1 BellSouth shall propose a firm price quote and a detailed implementation plan within thirty (30) business days of receipt of Clearwave Communications's acceptance of the preliminary analysis.
- 2.5.2 Clearwave Communications shall have thirty (30) business days from receipt of firm price quote to accept or deny the firm price quote and submit any additional nonrecurring, non-refundable fees quoted in the firm price quote.



- 2.6 Unless Clearwave Communications agrees otherwise, all prices shall be consistent with the pricing principles of the Act, FCC and/or the Commission.
- 2.7 If Clearwave Communications believes that BellSouth's firm price quote is not consistent with the requirements of the Act, or if either Party believes that the other is not acting in good faith in requesting, negotiating or processing the BFR, either Party may seek FCC or Commission arbitration, as appropriate, to resolve the dispute. Any such arbitration applicable to Unbundled Network Elements and/or Interconnection shall be conducted in accordance with standards prescribed in Section 252 of the Act.
- 2.8 Upon agreement to the rates, terms and conditions of a BFR, an amendment to this Agreement may be required.
- 3.0 **NEW BUSINESS REQUEST**
- 3.1 A New Business Request (NBR) is to be used by Clearwave Communications to make a request of BellSouth for a new or modified feature or capability of an existing product or service, a new product or service that is not deployed within the BellSouth network or operations and business support systems, or a new or modified service option that was not previously included in this Agreement (Requested Enhanced Services).
- 3.2 An NBR shall be submitted in writing by Clearwave Communications and shall specifically identify the requested service date, technical requirements, space requirements and/or such specifications that clearly define the request such that BellSouth has sufficient information to analyze and prepare a response. The request shall be sent to Clearwave Communications's designated BellSouth Sales contact.
- 3.3 If BellSouth determines that the preliminary analysis of the requested NBR is of such complexity that it will cause BellSouth to expend inordinate resources to evaluate the NBR, BellSouth shall notify Clearwave Communications that a fee will be required prior to the evaluation of the NBR. Clearwave Communications shall submit such fee within ten (10) business days of BellSouth's notice that a fee is required. BellSouth shall use reasonable efforts to respond to the NBR within (30) business days following BellSouth's receipt of the fee by providing a preliminary analysis of such Requested Enhanced Services that are the subject of the NBR. The preliminary analysis shall either confirm that BellSouth will offer access to the Requested Enhanced Services or confirm that BellSouth will not offer the Requested Enhanced Services. If the preliminary

analysis states that BellSouth will not offer the Requested Services, BellSouth will provide an explanation of why the request is not technically feasible, does not qualify as an NBR for the Requested Services or is otherwise not required to be provided under the Act. If preliminary analysis of the requested NBR is not of such complexity that it will cause BellSouth to expend inordinate resources to evaluate the NBR, BellSouth will use reasonable efforts to respond to Clearwave Communications within thirty (30) business days of its receipt of an NBR by providing a preliminary analysis of such Requested Services that are the subject of the NBR. The preliminary analysis shall either confirm that BellSouth will offer access to the Requested Enhanced Services or confirm that BellSouth will not offer the Requested Enhanced Services. If the preliminary analysis states that BellSouth will not offer the Requested Services, BellSouth will provide an explanation of why the request is not technically feasible, does not qualify as an NBR for the Requested Services or is otherwise not required to be provided under the Act.

- 3.4 Clearwave Communications may cancel an NBR at any time. If Clearwave Communications cancels the request more than ten (10) business days after submitting it, Clearwave Communications shall pay BellSouth's reasonable and demonstrable costs of processing and/or implementing the NBR up to the date of cancellation in addition to any fee submitted in accordance with Section 3.3 above.
- 3.5 Clearwave Communications will have thirty (30) business days from receipt of preliminary analysis to accept the preliminary analysis or cancel the NBR as set forth in section 3.4. Acceptance of the preliminary analysis must be in writing and accompanied by all nonrecurring charges quoted in the preliminary analysis. The nonrecurring charges as stated in the preliminary analysis cover the initial work required to develop the project plan, create the design parameters, and establish all activities and resources required to complete the NBR. If Clearwave Communications fails to respond within this 30-day period, the NBR will be deemed cancelled.
- 3.6 If Clearwave Communications accepts the preliminary analysis, BellSouth shall propose a firm price quote and a detailed implementation plan within sixty (60) business days of receipt of Clearwave Communications's acceptance of the preliminary analysis and nonrecurring fees quoted in the preliminary analysis.
- 3.7 Clearwave Communications shall have thirty (30) business days from receipt of the firm price quote to accept or deny the firm price quote and submit any additional nonrecurring, non-refundable fees quoted in the firm price quote.

- 3.8 Upon agreement to the terms of a NBR, an amendment to this Agreement, or a separate agreement, may be required.