

BELLSOUTH® / CLEC Agreement

Customer Name: Level 3 Communications, LLC

Level3 Communications, LLC Renegotiation	2
Table of Contents	3
General Terms and Conditions	4
ATT01 Resale	30
ATT01Rates	71
ATT02UNE	72
ATT02Rates	150
ATT03Local Interconnection	227
ATT03Rates	261
ATT04Collocation	268
ATT05NumberPortability	335
ATT05Rates	344
ATT06Ordering	345
ATT07Billing	351
ATT07Rates	370
ATT08ROW,Conduits and Pole Attachments	371
ATT09 Performance Measurements	373
ATT10Implementation	479
ATT11Disaster Recovery Plan	489
LA Cert. ID Amend	500
Att3-Bill&Keep 5/8/02	502

**INTERCONNECTION
AGREEMENT
BETWEEN
BELLSOUTH TELECOMMUNICATIONS INC.
AND
Level 3 Communications, LLC**

TABLE OF CONTENTS

General Terms and Conditions

Part A

1. Purpose
2. Term of the Agreement
3. Ordering Procedures
4. Parity
5. White Pages Listings
6. Bona Fide Request/New Business Request Process for Further Unbundling
7. Court Ordered Requests for Call Detail Records and Other Subscriber Information
8. Liability and Indemnification
9. Intellectual Property Rights and Indemnification
10. Treatment of Proprietary and Confidential Information
11. Assignments
12. Resolution of Disputes
13. Taxes
14. Force Majeure
15. Modification of Agreement
16. Waivers
17. Governing Law
18. Arm's Length Negotiations
19. Notices
20. Rule of Construction
21. Headings of No Force or Effect
22. Multiple Counterparts
23. Implementation of Agreement
24. Interference or Impairment
25. Filing of Agreement
26. Guides
27. Entire Agreement

Part B - Definitions

Attachment 1 - Resale

Attachment 2 - Network Elements and Other Services

Attachment 3 - Network Interconnection

Attachment 4 - Physical Collocation

Attachment 5 - Access to Numbers and Number Portability

Attachment 6 - Ordering and Provisioning

Attachment 7 - Billing and Billing Accuracy Certification

Attachment 8 - Rights-of-Way, Conduits and Pole Attachments

Attachment 9 - Performance Measurements

Attachment 10- Agreement Implementation Template

Attachment 11 – BellSouth Disaster Recovery Plan

AGREEMENT

THIS AGREEMENT is made by and between BellSouth Telecommunications, Inc., (“BellSouth”), a Georgia corporation, and Level 3 Communications, LLC, (“Level 3”) a Delaware limited liability company, and shall be deemed effective as of January 1, 2001. This Agreement may refer to either BellSouth or Level 3 or both as a “Party” or “Parties.”

WITNESSETH

WHEREAS, for purposes of this Agreement, BellSouth is a local exchange telecommunications company authorized to provide telecommunications services in the states of Alabama, Florida, Georgia, Kentucky, Louisiana, Mississippi, North Carolina, South Carolina, and Tennessee; and

WHEREAS, for purposes of this Agreement, Level 3 is or seeks to become an alternative local exchange telecommunications company (“CLEC”) authorized to provide telecommunications services in the states of Alabama, Florida, Georgia, Kentucky, Louisiana, Mississippi, North Carolina, South Carolina, and Tennessee; and

WHEREAS, the Parties wish to resell BellSouth’s telecommunications services and/or interconnect their facilities, purchase BellSouth network elements and other services, and exchange traffic pursuant to sections 251 and 252 of the Telecommunications Act of 1996 (“the Act”).

NOW THEREFORE, in consideration of the mutual agreements contained herein, BellSouth and Level 3 agree as follows:

1. Purpose

The resale, access and interconnection obligations contained herein are intended to be performed in accordance with Sections 251 and 252 of the Act, and designed to enable Level 3 to provide competing telephone exchange service to subscribers within the territory of BellSouth.

2. Term of the Agreement

2.1 The term of this Agreement shall be through December 31, 2003 and shall apply to the state(s) of Alabama, Florida, Georgia, Kentucky, Louisiana, Mississippi, North Carolina, South Carolina, and Tennessee. Upon mutual written agreement of the Parties, this Agreement may be renewed for such additional period of time as the Parties may agree.

2.2 The Parties agree that if either Party provides notice of intent to renegotiate no later than one hundred and eighty (180) days prior, and no sooner than two

hundred and seventy (270) days prior, to the expiration of this Agreement, they shall negotiate as soon as practicable with regard to the terms, conditions and prices of resale and/or local interconnection to be effective beginning on the expiration date of this Agreement (“Subsequent Agreement”). If as of the expiration of this Agreement a Subsequent Agreement has not been executed by the Parties, this Agreement shall continue on a month-to-month basis while a Subsequent Agreement is being negotiated or arbitrated. The Parties’ rights and obligations with respect to this Agreement after expiration shall be as set forth in Section 2.4 below.

2.3 If, within one hundred and thirty-five (135) to one hundred and sixty (160) days of commencing the negotiation referred to in Section 2.2 above, the Parties are unable to satisfactorily negotiate new resale and/or local interconnection terms, conditions and prices, either Party may petition the Commission to establish appropriate local interconnection and/or resale arrangements pursuant to 47 U.S.C. 252. The Parties agree that, in such event, they shall encourage the Commission to issue its order regarding the appropriate local interconnection and/or resale arrangements no later than the expiration date of this Agreement. The Parties further agree that in the event the Commission does not issue its order prior to the expiration date of this Agreement, or if the Parties continue beyond the expiration date of this Agreement to negotiate the local interconnection and/or resale arrangements without Commission intervention, the terms, conditions and prices ultimately ordered by the Commission, or negotiated by the Parties, will be effective retroactive to the day following the expiration date of this Agreement.

2.4 In those circumstances where a Party has delivered notice pursuant to Section 2.2, in the event that as of the date of expiration of this Agreement and conversion of this Agreement to a month-to-month term, the Parties have not entered into a Subsequent Agreement and (i) the Parties are not involved in active good faith negotiations or mediation for a Subsequent Agreement, or (ii) no arbitration proceeding has been filed in accordance with Section 2.3 above, then either Party may terminate this Agreement upon sixty (60) days notice to the other Party. In the event that BellSouth terminates this Agreement as provided above, BellSouth shall continue to offer services to Level 3 pursuant to the terms, conditions and rates set forth in BellSouth's Statement of Generally Available Terms (SGAT) to the extent an SGAT has been approved by the applicable Commission(s). If any state Commission has not approved a BellSouth SGAT, then upon BellSouth's termination of this Agreement as provided herein, BellSouth will continue to provide services to Level 3 pursuant to BellSouth's then current standard interconnection agreement. In the event that the SGAT or BellSouth's standard interconnection agreement becomes effective as between the Parties, the Parties may continue to negotiate a Subsequent Agreement, and the terms of such Subsequent Agreement shall be effective retroactive to the day following expiration of this Agreement.

3. Ordering Procedures

- 3.1 If such information has not already been provided, Level 3 shall provide BellSouth, if applicable, its Carrier Identification Code (CIC), Operating Company Number (OCN), Group Access Code (GAC) and Access Customer Name and Address (ACNA) code as applicable prior to placing its first order.
- 3.2 The Parties agree to adhere to the BellSouth Local Interconnection and Facility Based Ordering Guide, Products and Services Interval Guide, Resale Ordering Guide, and such other BellSouth Guides referenced herein (together, “Guides”) as appropriate for the services ordered.
- 3.3 Level 3 shall pay charges for Operational Support Systems (OSS) as set forth in this Agreement in Attachment 1 and/or in Attachment 2, 3, 5 and 7 as applicable.

4. Parity

When Level 3 purchases, pursuant to Attachment 1 of this Agreement, telecommunications services from BellSouth for the purposes of resale to end users, BellSouth shall provide said services so that the services are equal in quality, subject to the same conditions, and provided within the same provisioning time intervals that BellSouth provides to its affiliates, subsidiaries, end users or any other third-party carrier. To the extent technically feasible, the quality of a Network Element, as well as the quality of the access to such Network Element provided by BellSouth to Level 3 shall be at least equal in quality to that which BellSouth provides to itself. The quality of the interconnection between the networks of BellSouth and the network of Level 3 shall be at a level that is equal to that which BellSouth provides itself, a subsidiary, an Affiliate, or any other party. The interconnection facilities shall be designed to meet the same technical criteria and service standards that are used within BellSouth’s network and shall extend to a consideration of service quality as perceived by end users and service quality as perceived by Level 3.

5. White Pages Listings

BellSouth shall provide Level 3 and their customers access to white pages directory listings under the following terms:

- 5.1 Listings. Level 3 shall provide all new, changed and deleted listings on a timely basis and BellSouth or its agent will include Level 3 residential and business customer listings in the appropriate White Pages (residential and business) or alphabetical directories. Directory listings will make no distinction between Level 3 and BellSouth subscribers. BellSouth shall use commercially reasonable efforts at parity to ensure the accurate listing of Level 3 customers.
- 5.2 Rates. Subscriber primary listing information in the White Pages shall be provided at no charge to Level 3 or its subscribers and Level 3 will provide subscriber listing

information to BellSouth at no charge; provided however, that orders regarding directory listings submitted separately from service orders will incur charges as stated in BellSouth's General Subscriber Services Tariff A.4.

- 5.3 Procedures for Submitting Level 3 Subscriber Information. BellSouth will provide to Level 3 a magnetic tape or computer disk containing the proper format for submitting subscriber listings. Level 3 will be required to provide BellSouth with directory listings and daily updates to those listings, including new, changed, and deleted listings, on a magnetic tape, computer disk, or other mutually agreed upon means. These procedures are detailed in BellSouth's Local Interconnection and Facility Based Ordering Guide.
- 5.4 Unlisted/Non-Published Subscribers. Level 3 will be required to provide to BellSouth the names, addresses and telephone numbers of all Level 3 customers that wish to be omitted from directories.
- 5.5 Inclusion of Level 3 Customers in Directory Assistance Database. BellSouth will include and maintain Level 3 subscriber listings in BellSouth's Directory Assistance databases at no charge and Level 3 shall provide such Directory Assistance listings at no charge. BellSouth and Level 3 will formulate appropriate procedures regarding lead time, timeliness, format, content, and correction of listing information.
- 5.6 Listing Information Confidentiality. BellSouth will accord Level 3's directory listing information the same level of confidentiality that BellSouth accords its own directory listing information, and BellSouth shall limit access to Level 3's customer proprietary confidential directory information to those BellSouth employees who are involved in the preparation of listings.
- 5.7 Optional Listings. Additional listings and optional listings will be offered by BellSouth at tariffed rates as set forth in the General Subscriber Services Tariff.
- 5.8 Delivery. BellSouth or its agent shall deliver White Pages directories to Level 3 subscribers at no charge and in the same manner, time and quantity as it provides its own customers.

6. Bona Fide Request/New Business Request Process for Further Unbundling

6.1 BellSouth shall, upon request of Level 3, provide to Level 3 access to its network elements at any technically feasible point for the provision of Level 3's telecommunications service in accordance with applicable law and FCC rules and orders. Any request by Level 3 for access to a network element, interconnection option, or for the provisioning of any service or product that is not already available shall be treated as a Bona Fide Request/New Business Request, and shall be submitted to BellSouth pursuant to the Bona Fide Request/New Business Request process set forth following.

6.2 BFR Not Required. Where the FCC or Commission, in a generic order, has required or shall require BellSouth to offer a network element, interconnection option, or service not covered in this Agreement, BellSouth shall offer to Level 3 said network element, interconnection option, or service in the same fashion as required by the generic proceeding and without submission of a BFR. If BellSouth provides any network element, interconnection option, or service that is not identified in this Agreement to itself, to any BellSouth affiliate, or to any other telecommunications carrier, BellSouth shall make available to Level 3, upon Level 3's request, and without submission of a BFR, the same network element, interconnection option, or service at parity. The Parties agree to amend the Agreement to include any rates, terms and conditions for any new network element, interconnection option, or service that BellSouth is required to make available to Level 3 under this section.

6.3 A Bona Fide Request/New Business Request shall be submitted in writing to Level 3's Account Manager by Level 3 and shall specifically identify the requested service date, technical requirements, space requirements and/or such specifications that clearly define the request such that BellSouth has sufficient information to analyze and prepare a response. Such a request also shall include Level 3's designation of the request as being (i) pursuant to the Telecommunications Act of 1996 or (ii) pursuant to the needs of the business.

6.4 To the extent possible, BellSouth will utilize information from previously developed BFRs to address similar arrangements in order to shorten the response times for the currently requested BFR and to decrease the development costs for the currently requested BFR. In the event Level 3 has submitted a BFR for a network element, interconnection option, or service and BellSouth determines in accordance with the provisions of this Section that the BFR is technically feasible, the Parties agree that Level 3's subsequent request or order for the identical type of network element, interconnection option, or service shall not be subject to the BFR process. To the extent BellSouth has previously deployed an identical network element, interconnection option, or service under a previous BFR for itself or any other carrier, a subsequent BFR is not required. However, BellSouth may require Level 3 to reimburse the initial requesting carrier a pro rata share of the development costs as defined below. Similarly, if BellSouth or another CLEC

avoids development costs because Level 3 has already paid such costs for a particular network element, interconnection option, or service, then BellSouth shall reimburse Level 3 a pro rata share of the development costs paid. For purposes of this Section, an “identical” request shall be one that is materially identical to a previous request with respect to the information provided.

- 6.5 BellSouth acknowledgment. Within five (5) business days of receipt of a BFR, BellSouth shall acknowledge in writing its receipt and identify its single point of contact responsible for responding to the BFR and shall request any additional information needed to process the BFR. Within five (5) business days of receipt by BellSouth of a BFR from Level 3, BellSouth agrees to confer with Level 3 to discuss the BFR to ensure that: (i) BellSouth properly understands Level 3’s BFR, and (ii) to inform Level 3 of the existence of any similar BFRs made by other parties. Notwithstanding the foregoing, BellSouth may request additional information from Level 3 at any time during the processing of the BFR. If BellSouth claims, in response to a BFR made under this Section, that it cannot offer a particular network element, interconnection option, or service because it is technically infeasible, BellSouth must specify in detail which technical specifications cannot be met.
- 6.6 Preliminary Analysis delivery. Unless otherwise agreed by both Parties in writing, within thirty (30) calendar days of its receipt of a BFR, BellSouth shall provide to Level 3 a Preliminary Analysis of the BFR. If BellSouth determines that it is not able to provide Level 3 a Preliminary Analysis within thirty (30) calendar days of BellSouth’s receipt of the BFR, BellSouth will inform Level 3 as soon as practicable. Level 3 and BellSouth will then determine a mutually agreeable date for delivery of the Preliminary Analysis. Within five (5) business days of Level 3’s receipt of the BellSouth Preliminary Analysis and upon Level 3’s request, BellSouth agrees to confer with Level 3 to discuss BellSouth’s Preliminary Analysis.
- 6.7 Preliminary Analysis details. The Preliminary Analysis will state whether BellSouth can meet Level 3’s requirements and shall include BellSouth’s proposed price (plus or minus 25 percent) and the date the BFR can be met. If BellSouth cannot provide the network element, interconnection option, or service by the requested date, it shall provide an alternative proposed date together with a detailed explanation as to why BellSouth is not able to meet Level 3’s requested date. The Preliminary Analysis also will include a detailed breakdown of the costs supporting the proposed price, including the development costs, as defined below, necessary to complete Level 3’s BFR. BellSouth also shall indicate in the Preliminary Analysis its agreement or disagreement with Level 3’s designation of the BFR as an obligation under the Telecommunications Act of 1996. If BellSouth does not agree with Level 3’s designation, it may use the Dispute Resolution process set forth in Section 12. In no event, however, shall any dispute delay BellSouth’s processing of the Request.

- 6.8 Notice to proceed. After providing the Preliminary Analysis to Level 3, BellSouth shall proceed with Level 3's BFR upon receipt of Level 3's written "notice to proceed." This "notice to proceed" shall not be construed by BellSouth as a waiver of Level 3's right to invoke any dispute resolution process as set forth in Section 12 as to any issue, including BellSouth's proposed price, the reasonable, demonstrable, and actual costs incurred in the event of Level 3's cancellation of a BFR, or the amount of development costs paid. All payments are subject to adjustment according to the outcome of the dispute resolution process. In no event shall any dispute delay BellSouth proceeding with completing the BFR.
- 6.9 Development costs. After receipt and review of BellSouth's Preliminary Analysis, if Level 3 decides to proceed, Level 3 agrees to pay the fixed amount identified in the Preliminary Analysis for the initial work required to develop the project plan, create the design parameters, and establish all activities and resources required to complete the BFR. These costs will be referred to as "development costs." The development costs identified in the Preliminary Analysis are fixed. Level 3 will begin processing the payment of development costs at the time it issues the written "notice to proceed" with payment due to BellSouth within 15 days of the issuance of the notice to proceed.
- 6.10 Interim payment in the event of price dispute. In the event of a dispute over payments made by Level 3 or requested by BellSouth, including development costs and any interim progress payment, upon BellSouth's written request, Level 3 agrees to negotiate an interim lump sum progress payment to compensate BellSouth for its reasonable, demonstrable and actual costs incurred in processing Level 3's BFR. The interim lump sum progress payment shall be calculated by determining the average between BellSouth's proposed price and Level 3's estimate of the price for processing its BFR. Level 3 agrees to pay 50% of this amount as the interim lump sum progress payment. If Level 3's proposed price is less than 50% of BellSouth's proposed price, the average shall be calculated by assuming that Level 3's price is exactly 50% of BellSouth's proposed price.
- 6.11 Firm quote delivery. As soon as possible, but in no event later than sixty-five (65) calendar days after receipt of the Request, BellSouth shall provide Level 3 with a firm BFR response that will include, at a minimum, the firm availability date, the installation intervals, a binding price quote, and a final detailed breakdown of all costs supporting the final price.
- 6.12 Acceptance or rejection of firm quote. Within thirty (30) calendar days after receipt of the firm BFR response from BellSouth, Level 3 will notify BellSouth in writing of its acceptance or rejection of BellSouth's proposal. If BellSouth receives no response to the firm quote from Level 3 within the thirty day time frame, BellSouth shall issue a written request for confirmation that Level 3 does not wish to proceed with the BFR. If BellSouth receives no response from Level 3 within five (5) calendar days of its written request for confirmation, BellSouth may consider the BFR/NBR canceled. Level 3 agrees to pay BellSouth the reasonable,

demonstrable, and actual costs directly related to complying with Level 3's BFR/NBR up to the date of cancellation.

6.13 Pricing Principles. Unless Level 3 agrees otherwise, all proposed prices shall be derived in accordance with the Act and any applicable FCC and Commission rules and regulations. Payments for services purchased under a BFR will be made as specified in this Agreement, unless otherwise agreed to by Level 3.

6.14 Amendment. Upon Level 3's acceptance of the firm quote by BellSouth, the Parties shall amend the Agreement to incorporate the network element, interconnection option, or service contemplated by the BFR. The amendment shall include all pertinent rates, terms and conditions and shall be filed with the appropriate regulatory Commission pursuant to the requirements of the Act.

7. **Court Ordered Requests for Call Detail Records and Other Subscriber Information**

To the extent technically feasible, where BellSouth provides resale or local switching to Level 3, BellSouth maintains call detail records for Level 3 end users for limited time periods and can respond to subpoenas and court ordered requests for this information. BellSouth shall maintain such information for Level 3 end users for the same length of time it maintains such information for its own end users.

7.1 BellSouth will respond to subpoenas and court ordered requests delivered directly to BellSouth for the purpose of providing call detail records when the targeted telephone numbers belong to Level 3 end users and where BellSouth maintains call detail records responsive to the law enforcement agency subpoena or court ordered request. Billing for such requests will be generated by BellSouth and directed to the law enforcement agency initiating the request. If BellSouth does not maintain the call detail records, BellSouth will direct the law enforcement agency initiating the request to Level 3.

7.2 Level 3 agrees that in cases where Level 3 receives subpoenas or court ordered requests for call detail records for targeted telephone numbers belonging to Level 3 end users, if Level 3 does not maintain the call detail records responsive to such requests, Level 3 will advise the law enforcement agency initiating the request to redirect the subpoena or court ordered request to BellSouth. Billing for call detail information will be generated by BellSouth and directed to the law enforcement agency initiating the request.

7.3 Level 3 will provide Level 3 end user and/or other customer information that is available to Level 3 in response to subpoenas and court orders for their own customer records. BellSouth will redirect subpoenas and court ordered requests for Level 3 end user and/or other customer information to Level 3 for the purpose of providing this information to the law enforcement agency.

8. **Liability and Indemnification**

8.1 BellSouth Liability. BellSouth shall take financial responsibility for its own actions in causing, or its lack of action in preventing, unbillable or uncollectible Level 3 revenues.

8.2 Level 3 Liability. In the event that Level 3 consists of two (2) or more separate entities as set forth in the preamble to this Agreement, all such entities shall be jointly and severally liable for the obligations of Level 3 under this Agreement.

8.3 Liability for Acts or Omissions of Third Parties. Neither BellSouth nor Level 3 shall be liable for any act or omission of another telecommunications company providing a portion of the services provided under this Agreement.

8.4 Limitation of Liability.

8.4.1

Except in the event of the gross negligence or willful misconduct of the Party seeking to rely on the limitation of liability in this Section, each Party's liability to the other for any loss, cost, claim, injury or liability or expense, including reasonable attorney's fees, relating to or arising out of any negligent act of omission in its performance of this Agreement, whether in contract or in tort, shall be limited to a credit for the actual cost of the services or functions not performed or performed improperly. To the extent that any other specific provision or provisions of this Agreement include a limitation of liability that is inconsistent with this Section, the limitation of liability associated with such specific provision or provisions shall apply, rather than this Section, in the event of any claim arising under the specific provision or provisions. In addition, this limitation of liability shall not apply to a Party's indemnification obligations under this Agreement.

8.4.2 Limitations in Tariffs and Contracts. A Party may, in its sole discretion, provide in its tariffs and contracts with its Customer and third parties that relate to any service, product or function provided or contemplated under this Agreement, that to the maximum extent permitted by Applicable Law, such Party shall not be liable to Customer or third Party for (i) any Loss relating to or arising out of this Agreement, whether in contract, tort or otherwise, that exceeds the amount such Party would have charged that applicable person for the service, product or function that gave rise to such Loss and (ii) Consequential Damages. To the extent that a Party elects not to place in its tariffs or contracts such limitations of liability, and the other Party incurs a Loss as a result thereof, such Party shall indemnify and reimburse the other Party for that portion of the Loss that would have been limited had the first Party included in its tariffs and contracts the limitations of liability that such other Party included in its own tariffs at the time of such Loss. Any such tariff term or condition shall not contradict or modify the

obligations of the Parties to each other under this Agreement and in the event of a conflict, this Agreement shall control.

- 8.4.3 Neither BellSouth nor Level 3 shall be liable for damages to the other's terminal location, POI or other Party's customers' premises resulting from the furnishing of a service, including, but not limited to, the installation and removal of equipment or associated wiring, except to the extent caused by a Party's negligence or willful misconduct or by a Party's failure to properly ground a local loop after disconnection.
- 8.4.4 Except in the case of willful misconduct or gross negligence, a Party shall not be responsible or liable for indirect, incidental, or consequential damages, including, but not limited to, economic loss or lost business or profits, damages arising from the use or performance of equipment or software, or the loss of use of software or equipment, or accessories attached thereto, delay, error, or loss of data. In connection with this limitation of liability, each Party recognizes that the other Party may, from time to time, provide advice, make recommendations, or supply other analyses related to the Services, or facilities described in this Agreement, and, while each Party shall use diligent efforts in this regard, the Parties acknowledge and agree that this limitation of liability shall apply to provision of such advice, recommendations, and analyses.
- 8.5 Indemnification for Certain Claims. The Party providing services hereunder, its affiliates and its parent company, shall be indemnified, defended and held harmless by the Party receiving services hereunder against any claim, loss or damage arising from the receiving Party's use of the services provided under this Agreement pertaining to (1) claims for libel, slander or invasion of privacy arising from the content of the receiving Party's own communications, or (2) any claim, loss or damage claimed by the customer of the Party receiving services arising from such Party's use or reliance on the providing Party's services, actions, duties, or obligations arising out of this Agreement.
- 8.6 Disclaimer. EXCEPT AS SPECIFICALLY PROVIDED TO THE CONTRARY IN THIS AGREEMENT, NEITHER PARTY MAKES ANY REPRESENTATIONS OR WARRANTIES TO THE OTHER PARTY CONCERNING THE SPECIFIC QUALITY OF ANY SERVICES, OR FACILITIES PROVIDED UNDER THIS AGREEMENT. THE PARTIES DISCLAIM, WITHOUT LIMITATION, ANY WARRANTY OR GUARANTEE OF MERCHANTABILITY OR FITNESS FOR A PARTICULAR PURPOSE, ARISING FROM COURSE OF PERFORMANCE, COURSE OF DEALING, OR FROM USAGES OF TRADE.

9. Intellectual Property Rights and Indemnification

- 9.1 No License. No patent, copyright, trademark or other proprietary right is licensed, granted or otherwise transferred by this Agreement. Level 3 is strictly

prohibited from any use, including but not limited to in sales, in marketing or advertising of telecommunications services, of any BellSouth name, service mark or trademark. BellSouth is strictly prohibited from any use, including but not limited to in sales, in marketing or advertising of telecommunications services, of any Level 3 name, service mark or trade mark.

- 9.2 Ownership of Intellectual Property. Any intellectual property which originates from or is developed by a Party shall remain in the exclusive ownership of that Party. Except for a limited license to use patents or copyrights to the extent necessary for the Parties to use any facilities or equipment (including software) or to receive any service solely as provided under this Agreement, no license in patent, copyright, trademark or trade secret, or other proprietary or intellectual property right now or hereafter owned, controlled or licensable by a Party, is granted to the other Party or shall be implied or arise by estoppel. It is the responsibility of each Party to ensure at no additional cost to the other Party that it has obtained any necessary licenses in relation to intellectual property of third Parties used in its network that may be required to enable the other Party to use any facilities or equipment (including software), to receive any service, or to perform its respective obligations under this Agreement.
- 9.3 Indemnification. The Party providing a service pursuant to this Agreement will defend the Party receiving such service or data provided as a result of such service against claims of infringement arising solely from the use by the receiving Party of such service and will indemnify the receiving Party for any damages awarded based solely on such claims in accordance with Section 8 of this Agreement.
- 9.4 Claim of Infringement. In the event that use of any facilities or equipment (including software), becomes, or in reasonable judgment of the Party who owns the affected network is likely to become, the subject of a claim, action, suit, or proceeding based on intellectual property infringement, then said Party shall promptly and at its sole expense, but subject to the limitations of liability set forth below:
- 9.4.1 modify or replace the applicable facilities or equipment (including software) while maintaining form and function, or
- 9.4.2 obtain a license sufficient to allow such use to continue.
- 9.4.3 In the event 9.4.1 or 9.4.2 are commercially unreasonable, then said Party may, terminate, upon reasonable notice, this contract with respect to use of, or services provided through use of, the affected facilities or equipment (including software), but solely to the extent required to avoid the infringement claim.
- 9.5 Exception to Obligations. Neither Party's obligations under this Section shall apply to the extent the infringement is caused by: (i) modification of the facilities or equipment (including software) by the indemnitee; (ii) use by the indemnitee of the

facilities or equipment (including software) in combination with equipment or facilities (including software) not provided or authorized by the indemnitor provided the facilities or equipment (including software) would not be infringing if used alone; (iii) conformance to specifications of the indemnitee which would necessarily result in infringement; or (iv) continued use by the indemnitee of the affected facilities or equipment (including software) after being placed on notice to discontinue use as set forth herein.

9.6 Exclusive Remedy. The foregoing shall constitute the Parties' sole and exclusive remedies and obligations with respect to a third party claim of intellectual property infringement arising out of the conduct of business under this Agreement.

10. Treatment of Proprietary and Confidential Information

10.1 Confidential Information. It may be necessary for BellSouth and Level 3 to provide each other with certain confidential information, including trade secret information, including but not limited to, technical and business plans, technical information, proposals, specifications, drawings, procedures, customer account data, call detail records and like information (hereinafter collectively referred to as "Information"). All Information shall be in writing or other tangible form and clearly marked with a confidential, private or proprietary legend. Any information conveyed orally will be reduced to a writing identifying such information as confidential, private or proprietary within ten (10) business days. The Information shall not be copied or reproduced in any form. BellSouth and Level 3 shall protect the Information received from distribution, disclosure or dissemination to anyone except employees, consultants and attorneys of BellSouth and Level 3 with a need to know such Information and which employees, consultants and attorneys agree to be bound by the terms of this Section. BellSouth and Level 3 will use the same standard of care to protect Information received as they would use to protect their own confidential and proprietary Information. Upon written request of the Party providing the Information, the receiving Party shall return all copies of such Information or destroy such Information. The Parties' obligations under this Section 10 shall survive and continue in effect until three (3) years after the expiration or termination date of this Agreement with regard to all Information exchanged during the term of this Agreement. Thereafter, the Parties' obligations hereunder survive and continue in effect with respect to any Information that is a trade secret under applicable law.

10.2 Exception to Obligation. Notwithstanding the foregoing, there will be no obligation on BellSouth or Level 3 to protect any portion of the Information that is: (1) made publicly available by the owner of the Information or lawfully disclosed by a person other than BellSouth or Level 3; (2) lawfully obtained from any source other than the owner of the Information; (3) previously known to the receiving Party without an obligation to keep it confidential; or (4) required by law to be disclosed, or disclosed to a court or governmental agency for the purpose of enforcing its rights under this Agreement. In the case of (4) the receiving Party

shall provide sufficient notice to the providing Party so that the providing Party may request of the court or governmental agency an appropriate protective order to protect the confidentiality of the Information. The receiving Party shall cooperate with the providing Party's efforts to seek the protective order.

11. Assignments

Any assignment by either Party to any non-affiliated entity of any right, obligation or duty, or of any other interest hereunder, in whole or in part, without the prior written consent of the other Party shall be void. A Party may assign this Agreement or any right, obligation, duty or other interest hereunder to an Affiliate company of the Party without the consent of the other Party. All obligations and duties of any Party under this Agreement shall be binding on all successors in interest and assigns of such Party. No assignment or delegation hereof shall relieve the assignor of its obligations under this Agreement in the event that the assignee fails to perform such obligations.

12. Resolution of Disputes

12.1 Each Party agrees to notify the other Party in writing of a dispute concerning this Agreement.

12.2 Procedures for resolution of billing disputes are set forth in Section 3 of Attachment 7 of this Agreement.

12.3 Procedures for resolution of all disputes other than billing disputes are set forth below.

12.3.1 If the Parties are unable to resolve the issues relating to the dispute in the normal course of business within 60 days after delivery of notice of the dispute, each of the parties shall appoint a designated representative who has authority to settle the dispute and who is at a higher level of management than the persons with direct responsibility for administration of this Agreement. The designated representatives shall meet as often as they reasonably deem necessary in order to discuss the dispute and negotiate in good faith in an effort to resolve such dispute.

12.3.2 If the Parties are unable to resolve issues related to the dispute within thirty (30) days after the Parties' appointment of designated representatives pursuant to Section 12.3, then either Party may file a complaint with the Commission to resolve such issues or proceed with any other remedy pursuant to law or equity.

12.3.3 Nothing in this Section shall be construed to preclude or limit either Party from seeking immediate injunctive relief from a court or agency with competent jurisdiction to the extent it deems necessary. Each Party reserves any rights it may have to seek judicial review of any ruling by the Commission concerning this Agreement.

13. Taxes

- 13.1 Definition. For purposes of this Section, the terms “taxes” and “fees” shall include but not limited to federal, state or local sales, use, excise, gross receipts or other taxes or tax-like fees of whatever nature and however designated (including tariff surcharges and any fees, charges or other payments, contractual or otherwise, for the use of public streets or rights of way, whether designated as franchise fees or otherwise) imposed, or sought to be imposed, on or with respect to the services furnished hereunder or measured by the charges or payments therefore, excluding any taxes levied on income or real or personal property.
- 13.2 Taxes and Fees Imposed Directly On Either Providing Party or Purchasing Party.
- 13.2.1 Taxes and fees imposed on the providing Party, which are not permitted or required to be passed on by the providing Party to its customer, shall be borne and paid by the providing Party.
- 13.2.2 Taxes and fees imposed on the purchasing Party, which are not required to be collected and/or remitted by the providing Party, shall be borne and paid by the purchasing Party.
- 13.3 Taxes and Fees Imposed on Purchasing Party But Collected And Remitted By Providing Party.
- 13.3.1 Taxes and fees imposed on the purchasing Party shall be borne by the purchasing Party, even if the obligation to collect and/or remit such taxes or fees is placed on the providing Party.
- 13.3.2 To the extent permitted by applicable law, any such taxes and/or fees shall be shown as separate items on applicable billing documents between the Parties. Each Party will use its best efforts to ensure that any such taxes or fees are billed or presented in a timely manner. Notwithstanding the foregoing, the purchasing Party shall remain liable for any such taxes and fees regardless of whether they are actually billed by the providing Party at the time that the respective service is billed.
- 13.3.3 If the purchasing Party determines that in its opinion any such taxes or fees are not payable, the providing Party shall not bill such taxes or fees to the purchasing Party if the purchasing Party provides written certification, reasonably satisfactory to the providing Party, stating that it is exempt or otherwise not subject to the tax or fee, setting forth the basis therefor, and satisfying any other requirements under applicable law. If any authority seeks to collect any such tax or fee that the purchasing Party has determined and certified not to be payable, or any such tax or fee that was not billed by the providing Party, the purchasing Party may contest the same in good faith, at its own expense. In any such contest, the purchasing Party shall promptly furnish the providing Party with copies of all filings in any

proceeding, protest, or legal challenge, all rulings issued in connection therewith, and all correspondence between the purchasing Party and the taxing authority.

- 13.3.4 In the event that all or any portion of an amount sought to be collected must be paid in order to contest the imposition of any such tax or fee, or to avoid the existence of a lien on the assets of the providing Party during the pendency of such contest, the purchasing Party shall be responsible for such payment and shall be entitled to the benefit of any refund or recovery.
- 13.3.5 If it is ultimately determined that any additional amount of such a tax or fee is due to the imposing authority, the purchasing Party shall pay such additional amount, including any interest and penalties thereon.
- 13.3.6 Notwithstanding any provision to the contrary, the purchasing Party shall protect, indemnify and hold harmless (and defend at the purchasing Party's expense) the providing Party from and against any such tax or fee, interest or penalties thereon, or other charges or payable expenses (including reasonable attorney fees) with respect thereto, which are incurred by the providing Party in connection with any claim for or contest of any such tax or fee.
- 13.3.7 Each Party shall notify the other Party in writing of any assessment, proposed assessment or other claim for any additional amount of such a tax or fee by a taxing authority; such notice to be provided, if possible, at least ten (10) days prior to the date by which a response, protest or other appeal must be filed, but in no event later than thirty (30) days after receipt of such assessment, proposed assessment or claim.
- 13.4 Taxes and Fees Imposed on Providing Party But Passed On To Purchasing Party.
- 13.4.1 Taxes and fees imposed on the providing Party, which are permitted or required to be passed on by the providing Party to its customer, shall be borne by the purchasing Party.
- 13.4.2 To the extent permitted by applicable law, any such taxes and/or fees shall be shown as separate items on applicable billing documents between the Parties. Each Party will use its best efforts to ensure that any such taxes or fees are billed or presented in a timely manner. Notwithstanding the foregoing, the purchasing Party shall remain liable for any such taxes and fees regardless of whether they are actually billed by the providing Party at the time that the respective service is billed.
- 13.4.3 If the purchasing Party disagrees with the providing Party's determination as to the application or basis for any such tax or fee, the Parties shall consult with respect to the imposition and billing of such tax or fee. If, after consultation in accordance with the preceding sentence, the purchasing Party does not agree with the providing Party's final determination as to the application or basis of a particular

tax or fee, and if the providing Party, after receipt of a written request by the purchasing Party to contest the imposition of such tax or fee with the imposing authority, fails or refuses to pursue such contest or to allow such contest by the purchasing Party, the purchasing Party may utilize the dispute resolution process outlined in this Agreement and Attachment 1. Utilization of the dispute resolution process shall not relieve the purchasing Party from liability for any tax or fee billed by the providing Party pursuant to this subsection during the pendency of such dispute resolution proceeding. In the event that the purchasing Party prevails in such dispute resolution proceeding, it shall be entitled to a refund in accordance with the final decision therein. Notwithstanding the foregoing, if at any time prior to a final decision in such dispute resolution proceeding the providing Party initiates a contest with the imposing authority with respect to any of the issues involved in such dispute resolution proceeding, the dispute resolution proceeding shall be dismissed as to such common issues and the final decision rendered in the contest with the imposing authority shall control as to such issues.

- 13.4.4 In the event that all or any portion of an amount sought to be collected must be paid in order to contest the imposition of any such tax or fee, or to avoid the existence of a lien on the assets of the providing Party during the pendency of such contest, the purchasing Party shall be responsible for such payment and shall be entitled to the benefit of any refund or recovery.
- 13.4.5 If it is ultimately determined that any additional amount of such a tax or fee is due to the imposing authority, the purchasing Party shall pay such additional amount, including any interest and penalties thereon.
- 13.4.6 Notwithstanding any provision to the contrary, the purchasing Party shall protect indemnify and hold harmless (and defend at the purchasing Party's expense) the providing Party from and against any such tax or fee, interest or penalties thereon, or other reasonable charges or payable expenses (including reasonable attorney fees) with respect thereto, which are incurred by the providing Party in connection with any claim for or contest of any such tax or fee.
- 13.4.7 Each Party shall notify the other Party in writing of any assessment, proposed assessment or other claim for any additional amount of such a tax or fee by a taxing authority; such notice to be provided, if possible, at least ten (10) days prior to the date by which a response, protest or other appeal must be filed, but in no event later than thirty (30) days after receipt of such assessment, proposed assessment or claim.
- 13.5 Mutual Cooperation. In any contest of a tax or fee by one Party, the other Party shall cooperate fully by providing records, testimony and such additional information or assistance as may reasonably be necessary to pursue the contest. Further, the other Party shall be reimbursed for any reasonable and necessary out-of-pocket copying and travel expenses incurred in assisting in such contest.

14. Force Majeure

In the event performance of this Agreement, or any obligation hereunder, is either directly or indirectly prevented, restricted, or interfered with by reason of fire, flood, earthquake or like acts of God, wars, revolution, civil commotion, explosion, acts of public enemy, embargo, acts of the government in its sovereign capacity, strikes, boycotts, or any other circumstances beyond the reasonable control and without the fault or negligence of the Party affected, the Party affected, upon giving prompt notice to the other Party, shall be excused from such performance on a day-to-day basis to the extent of such prevention, restriction, or interference (and the other Party shall likewise be excused from performance of its obligations on a day-to-day basis until the delay, restriction or interference has ceased); provided however, that the Party so affected shall use diligent efforts to avoid or remove such causes of non-performance and both Parties shall proceed whenever such causes are removed or cease. Each Party agrees to treat the other Party in parity with the manner in which it treats itself and any other entities with regard to a Force Majeure event.

15. Modification of Agreement

- 15.1 Upon written request, BellSouth shall make available, pursuant to 47 USC § 252 and the FCC rules and regulations regarding such availability, to Level 3 any interconnection, service, or network element provided under any other agreement filed and approved pursuant to 47 USC § 252. The adopted interconnection, service, or network element and agreement shall apply to the same states as such other agreement and for the identical term of such other agreement.
- 15.2 If either Party changes its name or makes changes to its company structure or identity due to a merger, acquisition, transfer or any other reason, it is the responsibility of that Party to notify the other Party of said change and request that an amendment to this Agreement, if necessary, be executed to reflect said change.
- 15.3 No modification, amendment, supplement to, or waiver of the Agreement or any of its provisions shall be effective and binding upon the Parties unless it is made in writing and duly signed by the Parties.
- 15.4 Execution of this Agreement by either Party does not confirm or imply that the executing Party agrees with any decision(s) issued pursuant to the Telecommunications Act of 1996 and the consequences of those decisions on specific language in this Agreement. Neither Party waives its rights to appeal or otherwise challenge any such decision(s) and each Party reserves all of its rights to pursue any and all legal and/or equitable remedies, including appeals of any such decision(s).
- 15.5 In the event that any final and nonappealable legislative, regulatory, judicial or other legal action materially affects any material terms of this Agreement, or the ability of Level 3 or BellSouth to perform any material terms of this Agreement, Level 3 or

BellSouth may, on thirty (30) days' written notice require that such terms be renegotiated, and the Parties shall renegotiate in good faith such mutually acceptable new terms as may be required. In the event that such new terms are not renegotiated within ninety (90) days after such notice, the Dispute shall be referred to the Dispute Resolution procedure set forth in Section 12.

- 15.6 If any provision of this Agreement, or the application of such provision to either Party or circumstance, shall be held invalid, the remainder of the Agreement, or the application of any such provision to the Parties or circumstances other than those to which it is held invalid, shall not be affected thereby, provided that the Parties shall attempt to reformulate such invalid provision to give effect to such portions thereof as may be valid without defeating the intent of such provision.

16. Waivers

A failure or delay of either Party to enforce any of the provisions hereof, to exercise any option which is herein provided, or to require performance of any of the provisions hereof shall in no way be construed to be a waiver of such provisions or options, and each Party, notwithstanding such failure, shall have the right thereafter to insist upon the specific performance of any and all of the provisions of this Agreement.

17. Governing Law

This Agreement shall be governed by, and construed and enforced in accordance with, the laws of the State of Georgia, without regard to its conflict of laws principles.

18. Arm's Length Negotiations

This Agreement was executed after arm's length negotiations between the undersigned Parties and reflects the conclusion of the undersigned that this Agreement is in the best interests of all Parties.

19. Notices

- 19.1 Every notice, consent, approval, or other communications required or contemplated by this Agreement shall be in writing and shall be delivered in person or given by postage prepaid mail, addressed to:

BellSouth Telecommunications, Inc.

CLEC Account Team
9th Floor
600 North 19th Street
Birmingham, Alabama 35203

and

General Attorney - COU
Suite 4300
675 W. Peachtree St.
Atlanta, GA 30375

Level 3 Communications, LLC

Director of Access Planning
Level 3 Communications, LLC
1025 Eldorado Blvd.
Broomfield, CO 80021

and

Michael R. Romano
Attorney
Level 3 Communications, LLC
1025 Eldorado Blvd
Broomfield, CO 80021

or at such other address as the intended recipient previously shall have designated by written notice to the other Party.

- 19.2 Where specifically required, notices shall be by certified or registered mail. Unless otherwise provided in this Agreement, notice by mail shall be effective on the date it is officially recorded as delivered by return receipt or equivalent, and in the absence of such record of delivery, it shall be presumed to have been delivered the fifth day, or next business day after the fifth day, after it was deposited in the mails.
- 19.3 BellSouth shall provide Level 3 notice via Internet posting of retail price changes and of changes to the terms and conditions of retail services available for resale.

20. Rule of Construction

No rule of construction requiring interpretation against the drafting Party hereof shall apply in the interpretation of this Agreement.

21. Headings of No Force or Effect

The headings of Articles and Sections of this Agreement are for convenience of reference only, and shall in no way define, modify or restrict the meaning or interpretation of the terms or provisions of this Agreement.

22. Multiple Counterparts

This Agreement may be executed multiple counterparts, each of which shall be deemed an original, but all of which shall together constitute but one and the same document.

23. Implementation of Agreement

Where the Parties have not already established a prior course of dealing, within 60 days of the execution of this Agreement, the Parties will adopt a schedule for the implementation of the Agreement. The schedule shall state with specificity time frames for submission of including but not limited to, network design, interconnection points, collocation arrangement requests, pre-sales testing and full operational time frames for interconnection of the Parties' networks. The implementation template in Attachment 10 of this Agreement may be used by the Parties during the implementation process.

24. Interference or Impairment

- 24.1 Notwithstanding any other provisions of this Attachment, neither Party shall use any product or service provided under this Agreement, any other service related thereto or used in combination therewith, or place or use any equipment or facilities in any manner that: 1) significantly degrades, interferes with or impairs service provided by the other Party or by any other entity or any person's use of its telecommunications service; 2) endangers or damages the equipment, facilities or other property of the other Party or of any other entity or person; 3) compromises the privacy of any communications; or 4) creates an unreasonable risk of injury or death to any individual or to the public. If either Party reasonably determines that any equipment or facilities of the other Party violates the provisions of this paragraph, the complaining Party shall give written notice to the violating Party, which notice shall direct the violating Party to cure the violation within forty-eight (48) hours of receipt of such written notice or, at a minimum, to commence curative measures within 24 hours and to exercise reasonable diligence to complete such measures as soon as possible thereafter. Upon the violating Party's receipt of the notice, the Parties agree to consult immediately and, if necessary, to inspect the arrangement.
- 24.2 Except in the case of the deployment of an advanced service which significantly degrades the performance of other advanced services or traditional voice band services as described in Section 24.3 below, if the violating Party fails to take curative action within 48 hours, or if the violation is of a character which poses an immediate and substantial threat of damage to property, injury or death to any person, or in the event of any other impairment or interference with the complaining Party's service or network or the service or network of any other entity, then the complaining Party may take such reasonable action as it deems appropriate to correct the violation, including without limitation discontinuance of

services to the violating Party and/or requesting expedited Commission resolution of the matter; provided, however, that neither Party shall have the right to interrupt electrical power to the other Party's equipment. The complaining Party will endeavor, but is not required, to provide notice to the violating Party prior to taking such action. The complaining Party shall not be liable to the violating Party for any damages arising from such action, except to the extent that such action by the complaining Party constitutes willful misconduct.

For purposes of this Section 24, the term "significantly degrade" shall mean an action that noticeably impairs a service from a user's perspective. Notwithstanding anything to the contrary in Section 24.2 above, in the case of the deployment of an advanced service which significantly degrades the performance of other advanced services or traditional voice band services and where the violating Party fails to take curative action within 48 hours, the complaining Party will establish before the relevant state commission that the technology deployment is causing the significant degradation. Any claims of network harm presented to the violating Party or, if subsequently necessary, the relevant state Commission, must be supported with specific and verifiable information. Where the complaining Party demonstrates that a deployed technology is significantly degrading the performance of other advanced services or traditional voice band services, the violating Party shall discontinue deployment of that technology and migrate its customers to technologies that will not significantly degrade the performance of other such services. Where the only degraded service itself is a known disturber, and the newly deployed technology satisfies at least one of the criteria for a presumption that is acceptable for deployment under section 47 C.F.R. 51.230, the degraded service shall not prevail against the newly-deployed technology.

25. Filing of Agreement

Upon execution of this Agreement it shall be filed with the appropriate state regulatory agency pursuant to the requirements of Section 252 of the Act. If the regulatory agency imposes any filing or public interest notice fees regarding the filing or approval of the Agreement, Level 3 shall be responsible for publishing the required notice and the publication and/or notice costs shall be split equally between BellSouth and Level 3.

26. Guides

This Agreement contains references to numerous Guides maintained by BellSouth, including, but not limited to, the BellSouth Local Interconnection and Facility Based Ordering Guide, BellSouth Resale Ordering Guide, BellSouth Products and Services Interval Guide, and the BellSouth Facility Based CLEC Activation Requirements Customer Guide (together, "Guides"). Where this Agreement references any BellSouth Guides, the Parties agree to adhere to such Guides, provided that these Guides do not affect the substantive rights and obligations of

the Parties under this Agreement. In the event of a conflict between this Agreement and any Guides, this Agreement controls.

27. Entire Agreement

This Agreement and its Attachments, incorporated herein by this reference, sets forth the entire understanding and supersedes prior Agreements between the Parties relating to the subject matter contained herein and merges all prior discussions between them, and neither Party shall be bound by any definition, condition, provision, representation, warranty, covenant or promise other than as expressly stated in this Agreement or as is contemporaneously or subsequently set forth in writing and executed by a duly authorized officer or representative of the Party to be bound thereby.

This Agreement may include attachments with provisions for the following services:

Network Elements and Other Services
Local Interconnection
Resale
Collocation

The following services are included as options for purchase by Level 3. Level 3 shall elect said services by written request to its Account Manager if applicable.

Optional Daily Usage File (ODUF)
Enhanced Optional Daily Usage File (EODUF)
Access Daily Usage File (ADUF)
Line Information Database (LIDB) Storage
Centralized Message Distribution Service (CMDS)
Calling Name (CNAM)

IN WITNESS WHEREOF, the Parties have executed this Agreement the day and year above first written.

BellSouth Telecommunications, Inc.

Level 3 Communications, LLC

Signature on file _____
Signature

____ Signature on file _____
Signature

____ Patrick C. Finlen _____
Name

____ Kevin J. Dundon _____
Name

____ Managing Director _____
Title

____ Sr. Vice President _____
Title

____ 4/25/01 _____
Date

____ 4/16/01 _____
Date

Definitions

Affiliate is defined as a person that (directly or indirectly) owns or controls, is owned or controlled by, or is under common ownership or control with, another person. For purposes of this paragraph, the term “own” means to own an equity interest (or equivalent thereof) of more than 10 percent.

Centralized Message Distribution System is the Telcordia (formerly BellCore) administered national system, based in Kansas City, Missouri, used to exchange Exchange Message Interface (EMI) formatted data among host companies.

Commission is defined as the appropriate regulatory agency in each of BellSouth’s nine state region, Alabama, Florida, Georgia, Kentucky, Louisiana, Mississippi, North Carolina, South Carolina, and Tennessee.

Daily Usage File is the compilation of messages or copies of messages in standard Exchange Message Interface (EMI) format exchanged from BellSouth to a CLEC.

Exchange Message Interface is the nationally administered standard format for the exchange of data among the Exchange Carriers within the telecommunications industry.

Information Service means the offering of a capability for generating, acquiring, storing, transforming, processing, retrieving, utilizing, or making available information via telecommunications, and includes electronic publishing, but does not include any use of any such capability for the management, control, or operation of a telecommunications system or the management of a telecommunications service.

Intercompany Settlements (ICS) is the revenue associated with charges billed by a company other than the company in whose service area such charges were incurred. ICS on a national level includes third number and credit card calls and is administered by Telcordia (formerly BellCore)’s Calling Card and Third Number Settlement System (CATS). Included is traffic that originates in one Regional Bell Operating Company’s (RBOC) territory and bills in another RBOC’s territory.

Local Interconnection is defined as the delivery of local traffic to be terminated on each Party’s network so that end users of either Party have the ability to reach end users of the other Party without the use of any access code or substantial delay in the processing of the call.

Local Traffic is defined as any telephone call that originates in one exchange and terminates in either the same exchange, or other local calling area associated with the originating exchange as such exchanges are defined and specified in Section A3 of BellSouth’s General Subscriber Service Tariff.

Message Distribution is routing determination and subsequent delivery of message data from one company to another. Also included is the interface function with CMDS, where appropriate.

Multiple Exchange Carrier Access Billing (“MECAB”) means the document prepared by the Billing Committee of the Ordering and Billing Forum (“OBF”), which functions under the auspices of the Carrier Liaison Committee of the Alliance for Telecommunications Industry Solutions (“ATIS”) and by Telcordia (formerly BellCore) as Special Report SR-BDS-000983, containing the recommended guidelines for the billing of Exchange Service access provided by two or more LECs and/or CLECs or by one LEC in two or more states within a single LATA.

Network Element is defined to mean a facility or equipment used in the provision of a telecommunications service. Such term may include, but is not limited to, features, functions, and capabilities that are provided by means of such facility or equipment, including but not limited to, subscriber numbers, databases, signaling systems, and information sufficient for billing and collection or used in the transmission, routing, or other provision of a telecommunications service. BellSouth offers access to the Network Elements, unbundled loops; network interface device; sub-loop elements; local switching; transport; tandem switching; operator systems; signaling; access to call-related databases; dark fiber as set forth in Attachment 2 of this Agreement.

Non-Intercompany Settlement System (NICS) is the Telcordia (formerly BellCore) system that calculates non-intercompany settlements amounts due from one company to another within the same RBOC region. It includes credit card, third number and collect messages.

Percent of Interstate Usage (PIU) is defined as a factor to be applied to terminating access services minutes of use to obtain those minutes that should be rated as interstate access services minutes of use. The numerator includes all interstate “non-intermediary” minutes of use, including interstate minutes of use that are forwarded due to service provider number portability less any interstate minutes of use for Terminating Party Pays services, such as 800 Services. The denominator includes all “non-intermediary”, local, interstate, intrastate, toll and access minutes of use adjusted for service provider number portability less all minutes attributable to terminating Party pays services.

Percent Local Usage (PLU) is defined as a factor to be applied to intrastate terminating minutes of use. The numerator shall include all “non-intermediary” local minutes of use adjusted for those minutes of use that only apply local due to Service Provider Number Portability. The denominator is the total intrastate minutes of use including local, intrastate toll, and access, adjusted for Service Provider Number Portability less intrastate terminating Party pays minutes of use.

Revenue Accounting Office (RAO) Status Company is a local exchange company/alternate local exchange company that has been assigned a unique RAO code. Message data exchanged among RAO status companies is grouped (i.e. packed) according to From/To/Bill RAO combinations.

Service Control Points (“SCPs”) are databases that store information and have the ability to manipulate data required to offer particular services.

Signal Transfer Points (“STPs”) are signaling message switches that interconnect Signaling Links to route signaling messages between switches and databases. STPs enable the exchange of

Signaling System 7 (“SS7”) messages between switching elements, database elements and STPs. STPs provide access to various BellSouth and third party network elements such as local switching and databases.

Signaling links are dedicated transmission paths carrying signaling messages between carrier switches and signaling networks. Signal Link Transport is a set of two or four dedicated 56 kbps transmission paths between Level 3 designated Signaling Points of Interconnection that provide a diverse transmission path and cross connect to a BellSouth Signal Transfer Point.

Telecommunications means the transmission, between or among points specified by the user, of information of the user’s choosing, without change in the form or content of the information as sent and received.

Telecommunications Service means the offering of telecommunications for a fee directly to the public, or to such classes of users as to be effectively available directly to the public, regardless of the facilities used.

Telecommunications Act of 1996 (“Act”) means Public Law 104-104 of the United States Congress effective February 8, 1996. The Act amended the Communications Act of 1934 (47, U.S.C. Section 1 et. seq.).

Attachment 1

Resale

TABLE OF CONTENTS

1. Discount Rates.....3

2. Definition of Terms.....3

3. General Provisions.....4

4. Bellsouth’s Provision of Services To Level 38

5. Maintenance of Services.....8

6. Establishment of Service9

7. Payment and Billing Arrangements..... 11

8. Discontinuance of Service ~~13~~14****

9. Line Information Database (LIDB) 15

10. RAO Hosting..... 15

11. Optional Daily Usage File (ODUF) ~~15~~16****

12. Enhanced Optional Daily Usage File (EODUF) 16

13. Calling Name Delivery (CNAM) Database Service 16

Exhibit A – Applicable Discounts/OSS Rates.....17

Exhibit B – Resale Restrictions.....20

Exhibit C – Line Information Database (LIDB) Storage Agreement.....22

Exhibit D – CMDS/ROA Hosting.....28

Exhibit E – Optional Daily Usage File ODUF).....33

Exhibit F – Enhanced Option Daily Usage File (EODUF).....37

Exhibit G – Calling Name Delivery (CNAM) Database Services.....40

Exhibit H – ODUF/EODUF/CMDS Rates.....Rate Table

RESALE

1. Discount Rates

The rates pursuant to which Level 3 is to purchase services from BellSouth for resale shall be at a discount rate off of the retail rate for the telecommunications service. The discount rates shall be as set forth in Exhibit A, attached hereto and incorporated herein by this reference. Such discount shall reflect the costs avoided by BellSouth when selling a service for wholesale purposes.

2. Definition of Terms

- 2.1 CUSTOMER OF RECORD means the entity responsible for placing application for service; requesting additions, rearrangements, maintenance or discontinuance of service; payment in full of charges incurred such as non-recurring, monthly recurring, toll, directory assistance, etc.
- 2.2 DEPOSIT means assurance provided by a customer in the form of cash, surety bond or bank letter of credit to be held by BellSouth.
- 2.3 END USER means the ultimate user of the telecommunications services.
- 2.4 END USER CUSTOMER LOCATION means the physical location of the premises where an end user makes use of the telecommunications services.
- 2.5 NEW SERVICES means functions, features or capabilities that are not currently offered by BellSouth. This includes packaging of existing services or combining a new function, feature or capability with an existing service.
- 2.6 OTHER/COMPETITIVE LOCAL EXCHANGE COMPANY (OLEC/CLEC) means a telephone company certificated by the public service commission(s) of BellSouth's franchised area to provide local exchange service within BellSouth's franchised area.
- 2.7 RESALE means an activity wherein a certificated CLEC, such as Level 3 subscribes to the telecommunications services of BellSouth and then reoffers those telecommunications services to the public (with or without "adding value").
- 2.8 RESALE SERVICE AREA means the area, as defined in a public service commission approved certificate of operation, within which a CLEC, such as Level 3, may offer resold local exchange telecommunications service.

3. General Provisions

- 3.1 Pursuant to the terms of this Attachment, Level 3 may resell any telecommunications service that BellSouth makes available at retail to customers who are not telecommunications carriers. Such services are available as set forth in BellSouth's General Subscriber Service Tariff and Private Line Service Tariff or as otherwise required by the Act and applicable FCC rules and orders. Such services are subject to the terms, and conditions specifically set forth herein.
- 3.2 All of the negotiated rates, terms and conditions set forth in this Attachment pertain to the resale of BellSouth's retail telecommunications services and other services specified in this Attachment. BellSouth shall make available telecommunications services for resale at the rates set forth in Exhibit A to this Agreement and subject to the exclusions and limitations set forth in Exhibit B to this Agreement. BellSouth does not however waive its rights to appeal or otherwise challenge any decision regarding resale that resulted in the discount rates contained in Exhibit A or the exclusions and limitations contained in Exhibit B. BellSouth reserves the right to pursue any and all legal and/or equitable remedies, including appeals of any decisions. If such appeals or challenges result in changes in the discount rates or exclusions and limitations, the parties agree that appropriate modifications to this Agreement will be made promptly to make its terms consistent with the outcome of the appeal.
- 3.3 Level 3 may purchase resale services from BellSouth for its own use in operating its business. The resale discount will apply to those services under the following conditions:
- 3.3.1 Level 3 must resell services to other end users.
- 3.3.2 Level 3 must order services through resale interfaces, i.e., the Local Carrier Service Center (LCSC) and/or appropriate Resale Account Teams pursuant to Section 3 of the General Terms and Conditions.
- 3.3.3 Level 3 cannot be an alternative local exchange telecommunications company for the single purpose of selling to itself.
- 3.4 The provision of services by BellSouth to Level 3 does not constitute a joint undertaking for the furnishing of any service.
- 3.5 Level 3 will be the customer of record for all services purchased from BellSouth. Except as specified herein, BellSouth will take orders from, bill and expect payment from Level 3 for all services.
- 3.6 Level 3 will be BellSouth's single point of contact for all services purchased pursuant to this Agreement. BellSouth shall have no contact with the end user except to the extent provided for herein. If an end user customer of Level 3 contacts BellSouth for

- customer care, BellSouth shall refer the customer directly to Level 3's customer care personnel without making any effort to market to the customer in the context of that contact and without making any remarks as to the services provided by Level 3. The parties agree to provide one another with toll-free contact numbers for such purposes.
- 3.7 BellSouth will continue to bill the end user for any services that the end user specifies it wishes to receive directly from BellSouth.
- 3.8 BellSouth maintains the right to serve directly any end user within the service area of Level 3. BellSouth will continue to directly market its own telecommunications products and services and in doing so may establish independent relationships with end users of Level 3. Each Party shall comply with rules regarding the use of Customer Proprietary Network Information (as that term is described in the Act) as set forth in Section 222 of the Act and in effective and applicable FCC rules and orders.
- 3.9 Neither Party shall interfere with the right of any person or entity to obtain service directly from the other Party.
- 3.10 Current telephone numbers may normally be retained by the end user. However, telephone numbers are the property of BellSouth and are assigned to the service furnished. Level 3 has no property right to the telephone number or any other call number designation associated with services furnished by BellSouth, and no right to the continuance of service through any particular central office. BellSouth reserves the right to change such numbers, or the central office designation associated with such numbers, or both, whenever BellSouth deems it necessary to do so in the conduct of its business.
- 3.11 For the purpose of the resale of BellSouth's telecommunications services by Level 3, BellSouth will provide Level 3 with an on line access to telephone numbers for reservation on a first come first serve basis. Such reservations of telephone numbers, on a pre-ordering basis shall be for a period of ninety (90) days. Level 3 acknowledges that there may be instances where there is a shortage of telephone numbers in a particular Common Language Location Identifier Code (CLLIC) and in such instances BellSouth may request that Level 3 cancel its reservations of numbers. Level 3 shall comply with such request, provided that BellSouth is subject to the same policies administered in a nondiscriminatory manner where such shortages of telephone numbers exist.
- 3.12 Further, upon Level 3's request, and for the purpose of the resale of BellSouth's telecommunications services by Level 3, BellSouth will reserve up to 100 telephone numbers per CLLIC, for Level 3's sole use. Such telephone number reservations shall be valid for ninety (90) days from the reservation date. Level 3 acknowledges that there may be instances where there is a shortage of telephone numbers in a particular CLLIC and in such instances BellSouth shall use its best efforts to reserve for a ninety (90) day period a sufficient quantity of Level 3's reasonable need in that particular

- CLLIC. BellSouth will apply any policies to address such shortages on a nondiscriminatory basis to itself, Level 3, and other carriers (including, but not limited to, its own affiliates and subsidiaries).
- 3.13 BellSouth may provide any service or facility for which a charge is not established herein, as long as it is offered on the same terms to Level 3.
- 3.14 Service is furnished subject to the condition that it will not be used for any unlawful purpose.
- 3.15 Service will be discontinued if any law enforcement agency advises that the service being used is in violation of the law.
- 3.16 BellSouth can refuse service when it has grounds to believe that service will be used in violation of the law.
- 3.17 BellSouth accepts no responsibility to any person for any unlawful act committed by Level 3 or its end users as part of providing service to Level 3 for purposes of resale or otherwise.
- 3.18 The characteristics and methods of operation of any circuits, facilities or equipment provided by any person or entity other than BellSouth shall not:
- 3.18.1 Interfere with or impair service over any facilities of BellSouth, its affiliates, or its connecting and concurring carriers involved in its service;
- 3.18.2 Cause damage to BellSouth's plant;
- 3.18.3 Impair the privacy of any communications; or
- 3.18.4 Create hazards to any BellSouth employees or the public.
- 3.19 Level 3 assumes the responsibility of notifying BellSouth regarding less than standard operations with respect to services provided by Level 3.
- 3.20 Facilities and/or equipment utilized by BellSouth to provide service to Level 3 remain the property of BellSouth.
- 3.21 White page directory listings will be provided for Level 3 customers on a nondiscriminatory basis in accordance with regulations set forth in Section A6 of the General Subscriber Services Tariff and will be available for resale.
- 3.22 BellSouth provides electronic access to customer record information. Access is provided through the Local Exchange Navigation System (LENS) and the Telecommunications Access Gateway (TAG). Customer Record Information includes but is not limited to, customer specific information in CRIS and RSAG. In addition,

- Level 3 shall provide to BellSouth access to customer record information including electronic access where available. Otherwise, Level 3 shall provide paper copies of customer record information within a reasonable period of time upon request by BellSouth. Customer Record Information is equivalent to but not limited to the type of customer specific information contained in CRIS and RSAG. The Parties agree not to view, copy, or otherwise obtain access to the customer record information of any customer without that customer's permission, and further agree that Level 3 and BellSouth will obtain access to customer record information only in strict compliance with applicable laws, rules, or regulations of the State in which the service is provided.
- 3.23 All costs incurred by BellSouth to develop and implement operational interfaces shall be recovered from Resellers who utilize the services. Charges for use of Operational Support Systems (OSS) shall be as set forth in Exhibit A of this Attachment.
- 3.24 Where available to BellSouth's end users, BellSouth shall provide the following telecommunications services at a discount to allow for voice mail services:
- Simplified Message Desk Interface ("SMDI") Message Waiting Indicator ("MWI") stutter dialtone and message waiting light feature capabilities
 - Call Forward on Busy/Don't Answer ("CF-B/DA")
 - Call Forward on Busy ("CF/B")
 - Call Forward Don't Answer ("CF/DA")
- Further, BellSouth messaging services set forth in BellSouth's Messaging Service Information Package shall be made available for resale without the wholesale discount.
- 3.25 BellSouth's Inside Wire Maintenance Service Plans may be made available for resale at rates, terms and conditions as set forth by BellSouth and without the wholesale discount.
- 3.26 Recovery of charges associated with implementing Number Portability through monthly charges assessed to end users has been authorized by the FCC. This end user line charge will be billed to Resellers of BellSouth's telecommunications services and will be as filed in FCC No. 1. This charge will not be discounted.
- 4. BellSouth's Provision of Services to Level 3**
- 4.1 Level 3 agrees that its resale of BellSouth services shall be as follows:
- 4.1.1 The resale of telecommunications services shall be limited to users and uses conforming to the class of service restrictions.

- 4.1.2 Hotel and Hospital PBX services are the only telecommunications services available for resale to Hotel/Motel and Hospital end users, respectively. Similarly, Access Line Service for Customer Provided Coin Telephones is the only local service available for resale to Independent Payphone Provider (IPP) customers. Shared Tenant Service customers can only be sold those local exchange access services available in BellSouth's A23 Shared Tenant Service Tariff in the states of Florida, Georgia, North Carolina and South Carolina, and in A27 in the states of Alabama, Kentucky, Louisiana, Mississippi and Tennessee.
- 4.1.3 BellSouth reserves the right to periodically audit services purchased by Level 3 to establish authenticity of use. Such audit shall not occur more than once in a calendar year, during Level 3's standard business hours and subject to confidentiality protection. Level 3 shall make any and all records and data available to BellSouth or BellSouth's auditors on a reasonable basis. BellSouth shall not make use of any of the information obtained during an audit pursuant to this section for any purpose other than to establish authenticity of use. BellSouth shall bear the cost of said audit.
- 4.2 Resold services can only be used in the same manner as specified in BellSouth's Tariffs. Resold services are subject to the same terms and conditions as are specified for such services when furnished to an individual end user of BellSouth in the appropriate section of BellSouth's Tariffs. Specific tariff features (e.g. a usage allowance per month), shall not be aggregated across multiple resold services.
- 4.3 Level 3 may resell services only within the specific resale service area as defined in its certificate.
- 4.4 Telephone numbers transmitted via any resold service feature are intended solely for the use of the end user of the feature. Resale of this information is prohibited.
- 5. Maintenance of Services**
- 5.1 Level 3 will adopt and adhere to the standards contained in the applicable CLEC Work Center Operational Understanding Agreement regarding maintenance and installation of service.
- 5.2 Services resold under BellSouth's Tariffs and facilities and equipment provided by BellSouth shall be maintained by BellSouth.
- 5.3 Level 3 or its end users may not rearrange, move, disconnect, remove or attempt to repair any facilities owned by BellSouth, other than by connection or disconnection to any interface means used, except with the written consent of BellSouth.
- 5.4 Level 3 accepts responsibility to notify BellSouth of situations that arise that may result in a service problem.

- 5.5 Level 3 will be BellSouth's single point of contact for all repair calls on behalf of Level 3's end users. The parties agree to provide one another with toll-free contact numbers for such purposes.
- 5.6 Level 3 will contact the appropriate repair centers in accordance with procedures established by BellSouth.
- 5.7 For all repair requests, Level 3 accepts responsibility for adhering to BellSouth's prescreening guidelines prior to referring the trouble to BellSouth.
- 5.8 BellSouth will bill Level 3 for handling troubles that are found not to be in BellSouth's network pursuant to its standard time and material charges. The standard time and material charges will be no more than what BellSouth charges to its retail customers for the same services.
- 5.9 BellSouth reserves the right to contact Level 3's end users, if deemed necessary, for maintenance purposes. In no event shall BellSouth make any effort to market to the customer in the context of that contact or make any remarks as to the services provided by Level 3.

6. Establishment of Service

- 6.1 After receiving certification as a local exchange company from the appropriate regulatory agency, to the extent Level 3 seeks to resell BellSouth services, Level 3 will provide the appropriate BellSouth service center the necessary documentation to enable BellSouth to establish a master account for Level 3's resold services. Such documentation shall include the Application for Master Account, proof of authority to provide telecommunications services, an Operating Company Number ("OCN") assigned by the National Exchange Carriers Association ("NECA") and a tax exemption certificate, if applicable. When necessary deposit requirements are met (pursuant to Section 6.7, if applicable), BellSouth will begin taking orders for the resale of service.
- 6.2 Service orders will be in a standard format designated by BellSouth.
- 6.3 When notification is received from Level 3 that a current end user of BellSouth will subscribe to Level 3's service, standard service order intervals for the appropriate class of service will apply.
- 6.4 BellSouth will not require end user confirmation prior to establishing service for Level 3's end user customer. Level 3 must, however, be able to demonstrate end user authorization upon request.
- 6.5 Level 3 will be the single point of contact with BellSouth for all subsequent ordering activity resulting in additions or changes to resold services except that BellSouth will

accept a request directly from the end user for conversion of the end user's service from Level 3 to BellSouth or will accept a request from another CLEC for conversion of the end user's service from Level 3 to the other LEC. BellSouth will notify Level 3 that such a request has been processed.

- 6.6 If BellSouth determines that an unauthorized change in local service to Level 3 has occurred, BellSouth will reestablish service with the appropriate local service provider and will assess Level 3 as the CLEC initiating the unauthorized change, the unauthorized change charge described in F.C.C. Tariff No. 1, Section 13 or applicable state tariff. Appropriate nonrecurring charges, as set forth in Section A4 of the General Subscriber Service Tariff, will also be assessed to Level 3. These charges can be adjusted if Level 3 provides satisfactory proof of authorization.
- 6.7 In order to safeguard its interest, BellSouth reserves the right to secure the account with a suitable form of security deposit, unless satisfactory credit has already been established. A CLEC may be deemed to have satisfactory credit if it rates a 5.0 or better on the Dun & Bradstreet Risk Assessment Monitor. In addition, in determining satisfactory credit, BellSouth evaluates factors such as payment history with suppliers, bank relationships, audited financial statement ratios, years in business, management history, number of liens, suits or judgments and pay history with BellSouth. To the extent not required as of the effective date of this Agreement, Level 3 shall not be required to furnish a security deposit or letter of credit to BellSouth absent an adverse material change in financial circumstances thereafter as determined in accordance with the foregoing factors. Such adverse material changes may be measured based upon changes that alone would not be deemed material but when considered in conjunction with past adverse trends, including adverse trends occurring prior to the effective date hereof, constitute an adverse material change.
- 6.7.1 Such security deposit shall take the form of an irrevocable Letter of Credit or other forms of security acceptable to BellSouth. Any such security deposit may be held during the continuance of the service as security for the payment of any and all amounts accruing for the service.
- 6.7.2 If a security deposit is required, such security deposit shall be made prior to the inauguration of service.
- 6.7.3 Such security deposit may not exceed two months' estimated billing.
- 6.7.4 The fact that a security deposit has been made in no way relieves Level 3 from complying with BellSouth's regulations as to advance payments and the prompt payment of bills on presentation nor does it constitute a waiver or modification of the regular practices of BellSouth providing for the discontinuance of service for non-payment of any sums due BellSouth.

- 6.7.5 BellSouth reserves the right to increase the security deposit requirements when, in its reasonable judgment, material changes in Level 3's financial circumstances so warrant and/or gross monthly billing has increased significantly beyond the level initially used to determine the security deposit.
- 6.7.6 In the event that Level 3 defaults on its account, service to Level 3 will be terminated in accordance with Section 8 of this Attachment and any security deposits held will be applied to its account.
- 6.7.7 Interest on a security deposit shall accrue and be paid in accordance with the terms in the appropriate BellSouth tariff.

7. Payment And Billing Arrangements

- 7.1 Prior to submitting orders to BellSouth for local service, a master account must be established for Level 3. Level 3 is required to provide the following before a master account is established: proof of PSC/PUC certification, the Application for Master Account, an Operating Company Number ("OCN") assigned by the National Exchange Carriers Association ("NECA") and a tax exemption certificate, if applicable.
- 7.2 BellSouth shall bill Level 3 on a current basis all applicable charges and credits.
- 7.3 Payment of all charges will be the responsibility of Level 3. Level 3 shall make payment to BellSouth for all services billed. BellSouth is not responsible for payments not received by Level 3 from Level 3's end user. BellSouth will not become involved in billing disputes that may arise between Level 3 and its end user. Payments made to BellSouth as payment on account will be credited to an accounts receivable master account and not to an end user's account.
- 7.4 BellSouth will render bills each month on established bill days for each of Level 3's accounts.
- 7.5 BellSouth will bill Level 3 in advance charges for all services to be provided during the ensuing billing period except charges associated with service usage, which will be billed in arrears. Charges will be calculated on an individual end user account level, including, if applicable, any charge for usage or usage allowances. BellSouth will also bill Level 3, and Level 3 will be responsible for and remit to BellSouth, all charges applicable to resold services including but not limited to 911 and E911 charges, telecommunications relay charges (TRS), and franchise fees.
- 7.6 The payment will be due by the next bill date (i.e., same date in the following month as the bill date) and is payable in immediately available funds. Payment is considered to have been made when received by BellSouth.

- 7.6.1 If the payment due date falls on a Sunday or on a Holiday which is observed on a Monday, the payment due date shall be the first non-Holiday day following such Sunday or Holiday. If the payment due date falls on a Saturday or on a Holiday which is observed on Tuesday, Wednesday, Thursday, or Friday, the payment due date shall be the last non-Holiday day preceding such Saturday or Holiday. If payment is not received by the payment due date, a late payment penalty, as set forth in section 7.8 following, shall apply.
- 7.6.2 If Level 3 requests multiple billing media or additional copies of bills, BellSouth will provide these at an appropriate charge to Level 3.
- 7.6.3 Billing Disputes
- 7.6.3.1 Each Party agrees to notify the other Party upon the discovery of a billing dispute. In the event of a billing dispute, the Parties will endeavor to resolve the dispute within sixty (60) calendar days of the Bill Date on which such disputed charges appear. Resolution of the dispute is expected to occur at the first level of management resulting in a recommendation for settlement of the dispute and closure of a specific billing period. If the issues are not resolved within the allotted time frame, the following resolution procedure will begin:
- 7.6.3.2 If the dispute is not resolved within sixty (60) days of the Bill Date, the dispute will be escalated to the second level of management for each of the respective Parties for resolution. If the dispute is not resolved within ninety (90) days of the Bill Date, the dispute will be escalated to the third level of management for each of the respective Parties for resolution
- 7.6.3.3 If the dispute is not resolved within one hundred and twenty (120) days of the Bill Date, the dispute will be escalated to the fourth level of management for each of the respective Parties for resolution.
- 7.6.3.4 If a Party disputes a charge and does not pay such charge by the payment due date, such charges shall be subject to late payment charges as set forth in the Late Payment Charges provision of this Attachment. If a Party disputes charges and the dispute is resolved in favor of such Party, the other Party shall credit the bill of the disputing Party for the amount of the disputed charges along with any late payment charges assessed no later than the second Bill Date after the resolution of the dispute. Accordingly, if a Party disputes charges and the dispute is resolved in favor of the other Party, the disputing Party shall pay the other Party the amount of the disputed charges and any associated late payment charges assessed no later than the second bill payment due date after the resolution of the dispute. BellSouth shall only assess interest on previously assessed late payment charges in a state where it has authority pursuant to its tariffs.

- 7.7 Upon proof of tax exempt certification from Level 3, the total amount billed to Level 3 will not include any taxes due from the end user to reflect the tax exempt certification and local tax laws. Level 3 will be solely responsible for the computation, tracking, reporting, and payment of taxes applicable to Level 3's end user.
- 7.8 If any portion of the payment is received by BellSouth after the payment due date as set forth preceding, or if any portion of the payment is received by BellSouth in funds that are not immediately available to BellSouth, then a late payment penalty shall be due to BellSouth. The late payment penalty shall be the portion of the payment not received by the payment due date times a late factor and will be applied on a per bill basis. The late factor shall be as set forth in Section A2 of the General Subscriber Services Tariff and Section B2 of the Private Line Service Tariff. Level 3 will be charged a fee for all returned checks as set forth in Section to A2 of the General Subscriber Services Tariff or in applicable state law.
- 7.9 Any switched access charges associated with interexchange carrier access to the resold local exchange lines will be billed by, and due to, BellSouth. No additional charges are to be assessed to Level 3
- 7.10 BellSouth will not perform billing and collection services for Level 3 as a result of the execution of this Agreement. All requests for billing services should be referred to the appropriate entity or operational group within BellSouth.
- 7.11 Pursuant to 47 CFR Section 51.617, BellSouth will bill Level 3 end user common line charges and Presubscribed Interexchange Carrier Charges identical to the charges BellSouth bills its end users as set forth in BellSouth FCC Tariff No. 1.
- 7.12 In general, BellSouth will not become involved in disputes between Level 3 and Level 3's end user customers over resold services. If a dispute does arise that cannot be settled without the involvement of BellSouth, Level 3 shall contact the designated Service Center for resolution. BellSouth will make every effort to assist in the resolution of the dispute and will work with Level 3 to resolve the matter in as timely a manner as possible. Level 3 may be required to submit documentation to substantiate the claim.

8. Discontinuance of Service

- 8.1 The procedures for discontinuing service to an end user are as follows:
- 8.1.1 Where possible, BellSouth will deny service to Level 3's end user on behalf of, and at the request of, Level 3, putting Level 3's end user in a "denied state." Upon restoration of the end user's service, restoral charges will apply and will be the responsibility of Level 3.
- 8.1.2 At the request of Level 3, BellSouth will disconnect a Level 3 end user customer.

- 8.1.3 All requests by Level 3 for denial or disconnection of an end user for nonpayment must be in writing.
- 8.1.4 Level 3 will be made solely responsible for notifying the end user of the proposed disconnection of the service.
- 8.1.5 BellSouth will continue to process calls made to the Annoyance Call Center and will advise Level 3 when it is determined that annoyance calls are originated from one of their end user's locations. BellSouth shall be indemnified, defended and held harmless by Level 3 and/or the end user against any claim, loss or damage arising from providing this information to Level 3. It is the responsibility of Level 3 to take the corrective action necessary with its end users who make annoying calls. Failure to do so will result in BellSouth's disconnecting the end user's service.
- 8.1.6 BellSouth may disconnect and reuse facilities when the facility is in a denied state and BellSouth has received an order to establish new service or transfer of service from an end user or an end user's CLEC at the same address served by the denied facility
- 8.2 The procedures for discontinuing service to Level 3 are as follows:
- 8.2.1 BellSouth reserves the right to suspend or terminate service upon thirty (30) days written notice for nonpayment of undisputed amounts or upon seven (7) days written notice in the event of prohibited, unlawful or improper use of the facilities or service, abuse of the facilities, or any other violation or noncompliance by Level 3 of the rules and regulations of BellSouth's Tariffs. If Level 3 should cure the alleged violation within the applicable notice time frame, BellSouth shall not suspend or terminate service.
- 8.2.2 If payment of undisputed amounts is not received by the bill day in the month after the original bill day, BellSouth may provide written notice to Level 3, that additional applications for service will be refused and that any pending orders for service will not be completed if payment is not received by the fifteenth day following the date of the notice. In addition BellSouth may, at the same time, give thirty (30) days notice to the person designated by Level 3 to receive notices of noncompliance, and discontinue the provision of existing services to Level 3 if Level 3 does not cure within the thirty (30) day timeframe. For purposes of this Section 8, "undisputed amounts" shall mean amounts charged to Level 3 for which Level 3 has not submitted good faith billing dispute in writing in accordance with Attachment 7 of this Agreement.
- 8.2.3 In the case of such discontinuance, all billed charges, as well as applicable termination charges, shall become due.
- 8.2.4 If BellSouth does not discontinue the provision of the services involved on the date specified in the thirty days notice and Level 3's noncompliance continues, nothing

- contained herein shall preclude BellSouth's right to discontinue the provision of the services to Level 3 without further notice.
- 8.2.5 If payment is not received or arrangements made for payment by the date given in the written notification, Level 3's services will be discontinued. Upon discontinuance of service on a Level 3's account, service to Level 3's end users will be denied. BellSouth will also reestablish service at the request of the end user or Level 3 upon payment of the appropriate connection fee and subject to BellSouth's normal application procedures. Level 3 is solely responsible for notifying the end user of the proposed disconnection of the service.
- 8.2.6 If within fifteen days after an end user's service has been denied no contact has been made in reference to restoring service, the end user's service will be disconnected.

9. Line Information Database (LIDB)

- 9.1 BellSouth will store in its Line Information Database (LIDB) records relating to service only in the BellSouth region. The LIDB Storage Agreement is included in this Attachment as Exhibit C.
- 9.2 BellSouth will provide LIDB Storage upon written request to Level 3 Account Manager stating requested activation date.

10. RAO Hosting

- 10.1 The RAO Hosting Agreement is included in this Attachment as Exhibit D. Rates for BellSouth's Centralized Message Distribution System (CMDS) are as set forth in Exhibit H of this Attachment.
- 10.2 BellSouth will provide RAO Hosting upon written request to its Account Manager stating requested activation date.

11. Optional Daily Usage File (ODUF)

- 11.1 The Optional Daily Usage File (ODUF) Agreement with terms and conditions is included in this Attachment as Exhibit E. Rates for ODUF are as set forth in Exhibit H of this Attachment.
- 11.2 BellSouth will provide Optional Daily Usage File (ODUF) service upon written request to its Account Manager stating requested activation date.

12. Enhanced Optional Daily Usage File (EODUF)

- 12.1 The Enhanced Optional Daily Usage File (EODUF) service Agreement with terms and conditions is included in this Attachment as Exhibit F. Rates for EODUF are as set forth in Exhibit H of this Attachment.
- 12.2 BellSouth will provide Enhanced Optional Daily Usage File (EODUF) service upon written request to its Account Manager stating requested activation date.

13. Calling Name Delivery (CNAM) Database Service

- 13.1 Calling Name Delivery (CNAM) Database Service Agreement is included in this Attachment as Exhibit G. Rates for CNAM are as set forth in Exhibit H of this Attachment.
- 13.2 BellSouth will provide Calling Name Delivery (CNAM) Database service upon written request to its Account Manager stating requested activation date.

APPLICABLE DISCOUNTS

The telecommunications services available for purchase by Level 3 for the purposes of resale to Level 3 end users shall be available at the following discount off of the retail rate.

DISCOUNT*

STATE	RESIDENCE	BUSINESS	CSAs***
ALABAMA	16.3%	16.3%	
FLORIDA	21.83%	16.81%	
GEORGIA	20.3%	17.3%	
KENTUCKY	16.79%	15.54%	
LOUISIANA	20.72%	20.72%	9.05%
MISSISSIPPI	15.75%	15.75%	
NORTH CAROLINA	21.5%	17.6%	
SOUTH CAROLINA	14.8%	14.8%	8.98%
TENNESSEE**	16%	16%	

* When a CLEC provides Resale service in a cross boundary area (areas that are part of the local serving area of another state's exchange) the rates, regulations and discounts for the tariffing state will apply. Billing will be from the serving state.

** In Tennessee, if a CLEC provides its own operator services and directory services, the discount shall be 21.56%. CLEC must provide written notification to BellSouth within 30 days prior to providing its own operator services and directory services to qualify for the higher discount rate of 21.56%.

*** Unless noted in this column, the discount for Business will be the applicable discount rate for CSAs.

OPERATIONAL SUPPORT SYSTEMS (OSS) RATES

BellSouth has developed and made available the following mechanized systems by which Level 3 may submit LSRs electronically.

LENS	Local Exchange Navigation System
EDI	Electronic Data Interface
EDI-PC	Electronic Data Interface – Personal Computer
TAG	Telecommunications Access Gateway

LSRs submitted by means of one of these interactive interfaces will incur an OSS electronic ordering charge as specified in the Table below. An individual LSR will be identified for billing purposes by its Purchase Order Number (PON). LSRs submitted by means other than one of these interactive interfaces (mail, fax, courier, etc.) will incur a manual order charge as specified in the table below:

OPERATIONAL SUPPORT SYSTEMS (OSS) RATES	<u>Electronic</u> Per LSR received from the CLEC by one of the OSS interactive interfaces	<u>Manual</u> Per LSR received from the CLEC by means other than one of the OSS interactive interfaces
OSS LSR Charge	\$3.50	\$19.99
USOC	SOMEK	SOMAN

Note: In addition to the OSS charges, applicable discounted service order and related discounted charges apply as per the tariff.

Denial/Restoral OSS Charge

In the event Level 3 provides a list of customers to be denied and restored, rather than an LSR, each location on the list will require a separate PON and, therefore will be billed as one LSR per location.

Cancellation OSS Charge

Level 3 will incur an OSS charge for an accepted LSR that is later canceled by Level 3.

Note: Supplements or clarifications to a previously billed LSR will not incur another OSS charge.

Threshold Billing Plan

The Parties agree that Level 3 will incur the mechanized rate for all LSRs, both mechanized and manual, if the percentage of mechanized LSRs to total LSRs **meets or** exceeds the threshold percentages shown below:

Year	Ratio: Mechanized/Total LSRs
2000	80%
2001	90%

The threshold plan will be discontinued in 2002.

BellSouth will track the total LSR volume for each CLEC for each quarter. At the end of that time period, a Percent Electronic LSR calculation will be made for that quarter based on the LSR data tracked in the LCSC. If this percentage exceeds the threshold volume, all of that CLECs' future manual LSRs will be billed at the mechanized LSR rate. To allow time for obtaining and analyzing the data and updating the billing system, this billing change will take place on the first day of the second month following the end of the quarter (e.g. May 1 for 1Q, Aug 1 for 2Q, etc.). There will be no adjustments to the amount billed for previously billed LSRs.

**EXCLUSIONS AND LIMITATIONS
ON SERVICES AVAILABLE FOR RESALE**

Type of Service		AL		FL		GA		KY		LA	
		Resale?	Discount?	Resale?	Discount?	Resale?	Discount?	Resale?	Discount?	Resale?	Discount?
1.	Grandfathered Services (Note 1)	Yes	Yes	Yes	Yes	Yes	Yes	Yes	Yes	Yes	Yes
2.	Contract Service Arrangements	Yes	Yes	Yes	Yes	Yes	Yes	Yes	Yes	Yes	Yes
3.	Promotions - > 90 Days(Note 2)	Yes	Yes	Yes	Yes	Yes	Yes	Yes	Yes	Yes	Yes
4.	Promotions - < 90 Days (Note 2)	Yes	No	Yes	No	Yes	No	Yes	No	Yes	No
5.	Lifeline/Link Up Services	Yes	Yes	Yes	Yes	Yes	Yes	Note 4	Note 4	Yes	Yes
6.	911/E911 Services	Yes	Yes	Yes	Yes	Yes	Yes	Yes	Yes	No	No
7.	N11 Services	Yes	Yes	Yes	Yes	Yes	Yes	No	No	No	No
8.	AdWatch SM Svc (See Note 6)	Yes	Yes	Yes	Yes	Yes	Yes	Yes	Yes	Yes	Yes
9.	MemoryCall [®] Service	Yes	No	Yes	No	Yes	No	Yes	No	Yes	No
10.	Mobile Services	Yes	No	Yes	No	Yes	No	Yes	No	Yes	No
11.	Federal Subscriber Line Charges	Yes	No	Yes	No	Yes	No	Yes	No	Yes	No
12.	Non-Recurring Charges	Yes	Yes	Yes	Yes	Yes	Yes	Yes	Yes	Yes	Yes
13.	End User Line Charge – Number Portability	Yes	No	Yes	No	Yes	No	Yes	No	Yes	No
14.	Public Telephone Access Service (PTAS)	Yes	Yes	Yes	Yes	Yes	Yes	Yes	Yes	Yes	Yes

Type of Service		MS		NC		SC		TN	
		Resale?	Discount?	Resale?	Discount?	Resale?	Discount?	Resale?	Discount ?
1.	Grandfathered Services (Note 1)	Yes	Yes	Yes	Yes	Yes	Yes	Yes	Yes
2.	Contract Service Arrangements	Yes	Yes	Yes	Yes	Yes	Yes	Yes	Yes
3.	Promotions - > 90 Days(Note 2)	Yes	Yes	Yes	Yes	Yes	Yes	Yes	Note 3
4.	Promotions - < 90 Days (Note 2)	Yes	No	No	No	Yes	No	Yes	No
5.	Lifeline/Link Up Services	Yes	Yes	Yes	Yes	Yes	Yes	Yes	Yes
6.	911/E911 Services	Yes	Yes	Yes	Yes	Yes	Yes	Yes	Yes
7.	N11 Services	Yes	Yes	Yes	Yes	No	No	Yes	Yes
8.	AdWatch SM Svc (See Note 6)	Yes	Yes	Yes	Yes	Yes	Yes	Yes	Yes
9.	MemoryCall [®] Service	Yes	No	Yes	No	Yes	No	Yes	No
10.	Mobile Services	Yes	No	Yes	No	Yes	No	Yes	No
11.	Federal Subscriber Line Charges	Yes	No	Yes	No	Yes	No	Yes	No
12.	Non-Recurring Charges	Yes	Yes	Yes	Yes	Yes	Yes	Yes	No
13.	End User Line Charge – Number Portability	Yes	No	Yes	No	Yes	No	Yes	No

Version3Q99:12/01/99

Exhibit B
Page 2 of 2

14.	Public Telephone Access Service (PTAS)	Yes	Yes	Yes	Yes	Yes	No	Yes	Yes
-----	--	-----	-----	-----	-----	-----	----	-----	-----

Applicable Notes:

1. **Grandfathered services** can be resold only to existing subscribers of the grandfathered service.
2. Where available for resale, **promotions** will be made available only to end users who would have qualified for the promotion had it been provided by BellSouth directly.
3. In Tennessee, long-term **promotions** (offered for more than ninety (90) days) may be obtained at one of the following rates:
 - (a) the stated tariff rate, less the wholesale discount;
 - (b) the promotional rate (the promotional rate offered by BellSouth will not be discounted further by the wholesale discount rate)
4. **Lifeline/Link Up** services may be offered only to those subscribers who meet the criteria that BellSouth currently applies to subscribers of these services as set forth in Sections A3 and A4 of the BellSouth General Subscriber Services Tariff.
5. Some of BellSouth's local exchange and toll telecommunications services are not available in certain central offices and areas.
6. AdWatchSM Service is tariffed as BellSouth[®] AIN Virtual Number Call Detail Service.

**LINE INFORMATION DATA BASE (LIDB)
STORAGE AGREEMENT**

I. SCOPE

- A. This Agreement sets forth the terms and conditions pursuant to which BellSouth agrees to store in its LIDB certain information at the request of Level 3 and pursuant to which BellSouth, its LIDB customers and Level 3 shall have access to such information. Level 3 understands that BellSouth provides access to information in its LIDB to various telecommunications service providers pursuant to applicable tariffs and agrees that information stored at the request of Level 3, pursuant to this Agreement, shall be available to those telecommunications service providers. The terms and conditions contained in the attached Addendum(s) are hereby made a part of this Agreement as if fully incorporated herein.
- B. LIDB is accessed for the following purposes:
1. Billed Number Screening
 2. Calling Card Validation
 3. Fraud Control
- C. BellSouth will provide seven days per week, 24-hours per day, fraud monitoring on Calling Cards, bill-to-third and collect calls made to numbers in BellSouth's LIDB, provided that such information is included in the LIDB query. BellSouth will establish fraud alert thresholds and will notify Level 3 of fraud alerts so that Level 3 may take action it deems appropriate. Level 3 understands and agrees BellSouth will administer all data stored in the LIDB, including the data provided by Level 3 pursuant to this Agreement, in the same manner as BellSouth's data for BellSouth's end user customers. BellSouth shall not be responsible to Level 3 for any lost revenue which may result from BellSouth's administration of the LIDB pursuant to its established practices and procedures as they exist and as they may be changed by BellSouth in its sole discretion from time to time.

Level 3 understands that BellSouth currently has in effect numerous billing and collection agreements with various interexchange carriers and billing clearing houses. Level 3 further understands that these billing and collection customers of BellSouth query BellSouth's LIDB to determine whether to accept various billing options from end users. Additionally, Level 3 understands that presently BellSouth has no method to differentiate between BellSouth's own billing and line data in the LIDB and such data which it includes in the LIDB on Level 3's behalf pursuant to this Agreement. Therefore, until such time as BellSouth can and does implement in its LIDB and its supporting systems the means to differentiate Level 3's data from BellSouth's data and the Parties to this Agreement execute appropriate amendments hereto, the following terms and conditions shall apply:

- (a) Level 3 agrees that it will accept responsibility for telecommunications services billed by BellSouth for its billing and collection customers for Level 3's end user accounts which are resident in LIDB pursuant to this Agreement. Level 3 authorizes BellSouth to place such charges on Level 3's bill from BellSouth and agrees that it shall pay all such charges. Charges for which Level 3 hereby takes responsibility include, but are not limited to, collect and third number calls.
- (b) Charges for such services shall appear on a separate BellSouth bill page identified with the name of the entity for which BellSouth is billing the charge.
- (c) Level 3 shall have the responsibility to render a billing statement to its end users for these charges, but Level 3's obligation to pay BellSouth for the charges billed shall be independent of whether Level 3 is able or not to collect from Level 3's end users.
- (d) BellSouth shall not become involved in any disputes between Level 3 and the entities for which BellSouth performs billing and collection. BellSouth will not issue adjustments for charges billed on behalf of an entity to Level 3. It shall be the responsibility of Level 3 and the other entity to negotiate and arrange for any appropriate adjustments.

II. TERM

This Agreement will be effective as of _____, and will continue in effect for one year, and thereafter may be continued until terminated by either Party upon thirty (30) days written notice to the other Party.

III. FEES FOR SERVICE AND TAXES

- A. Level 3 will not be charged a fee for storage services provided by BellSouth to Level 3, as described in Section I of this Agreement.
- B. Sales, use and all other taxes (excluding taxes on BellSouth's income) determined by BellSouth or any taxing authority to be due to any federal, state or local taxing jurisdiction with respect to the provision of the service set forth herein will be paid by Level 3. Level 3 shall have the right to have BellSouth contest with the imposing jurisdiction, at Level 3's expense, any such taxes that Level 3 deems are improperly levied.

IV. INDEMNIFICATION

To the extent not prohibited by law, each Party will indemnify the other and hold the other harmless against any loss, cost, claim, injury, or liability relating to or arising out of negligence or willful misconduct by the indemnifying Party or its agents or contractors in connection with the indemnifying Party's provision of services, provided, however, that any indemnity for any loss, cost, claim, injury or liability arising out of or relating to errors or omissions in the provision of services under this Agreement shall be limited as otherwise specified in this Agreement. The indemnifying Party under this Section agrees to defend any suit brought against the other Party for any such loss, cost, claim, injury or liability. The indemnified Party agrees to notify the other Party promptly, in writing, of any written claims, lawsuits, or demands for which the other Party is responsible under this Section and to cooperate in every reasonable way to facilitate defense or settlement of claims. The indemnifying Party shall not be liable under this Section for settlement by the indemnified Party of any claim, lawsuit, or demand unless the defense of the claim, lawsuit, or demand has been tendered to it in writing and the indemnifying Party has unreasonably failed to assume such defense.

V. LIMITATION OF LIABILITY

Neither Party shall be liable to the other Party for any lost profits or revenues or for any indirect, incidental or consequential damages incurred by the other Party arising from this Agreement or the services performed or not performed hereunder, regardless of the cause of such loss or damage.

VI. MISCELLANEOUS

- A. It is understood and agreed to by the Parties that BellSouth may provide similar services to other companies.
- B. All terms, conditions and operations under this Agreement shall be performed in accordance with, and subject to, all applicable local, state or federal legal and regulatory tariffs, rulings, and other requirements of the federal courts, the U. S. Department of Justice and state and federal regulatory agencies. Nothing in this Agreement shall be construed to cause either Party to violate any such legal or regulatory requirement and either Party's obligation to perform shall be subject to all such requirements.
- C. Level 3 agrees to submit to BellSouth all advertising, sales promotion, press releases, and other publicity matters relating to this Agreement wherein BellSouth's corporate or trade names, logos, trademarks or service marks or those of BellSouth's affiliated companies are mentioned or language from which the connection of said names or trademarks therewith may be inferred or implied; and Level 3 further agrees not to publish or use advertising, sales promotions, press releases, or publicity matters as described immediately above without BellSouth's prior written approval.
- D. This Agreement constitutes the entire Agreement between Level 3 and BellSouth which supersedes all prior Agreements or contracts, oral or written representations,

statements, negotiations, understandings, proposals and undertakings with respect to the subject matter hereof.

- E. Except as expressly provided in this Agreement, if any part of this Agreement is held or construed to be invalid or unenforceable, the validity of any other Section of this Agreement shall remain in full force and effect to the extent permissible or appropriate in furtherance of the intent of this Agreement.
- F. Neither Party shall be held liable for any delay or failure in performance of any part of this Agreement for any cause beyond its control and without its fault or negligence, such as acts of God, acts of civil or military authority, government regulations, embargoes, epidemics, war, terrorist acts, riots, insurrections, fires, explosions, earthquakes, nuclear accidents, floods, strikes, power blackouts, volcanic action, other major environmental disturbances, unusually severe weather conditions, inability to secure products or services of other persons or transportation facilities, or acts or omissions of transportation common carriers.
- G. This Agreement shall be deemed to be a contract made under the laws of the State of Georgia, and the construction, interpretation and performance of this Agreement and all transactions hereunder shall be governed by the domestic law of such State.

**RESALE ADDENDUM
TO LINE INFORMATION DATA BASE (LIDB)
STORAGE AGREEMENT**

This is a Resale Addendum to the Line Information Data Base Storage Agreement dated _____, 199 __, between BellSouth Telecommunications, Inc. (“BellSouth”), and Level 3 (“Level 3”), effective the ____ day of _____, 199 __.

I. GENERAL

This Addendum sets forth the terms and conditions for Level 3’s provision of billing number information to BellSouth for inclusion in BellSouth’s LIDB. BellSouth will store in its LIDB the billing number information provided by Level 3, and BellSouth will provide responses to on-line, call-by-call queries to this information for purposes specified in Section I.B. of the Agreement.

II. DEFINITIONS

- A. Billing number - a number used by BellSouth for the purpose of identifying an account liable for charges. This number may be a line or a special billing number.
- B. Line number - a ten digit number assigned by BellSouth that identifies a telephone line associated with a resold local exchange service, or with a SPNP arrangement.
- B. Special billing number - a ten digit number that identifies a billing account established by BellSouth in connection with a resold local exchange service or with a SPNP arrangement.
- D. Calling Card number - a billing number plus PIN number assigned by BellSouth.
- E. PIN number - a four digit security code assigned by BellSouth which is added to a billing number to compose a fourteen digit calling card number.
- F. Toll billing exception indicator - associated with a billing number to indicate that it is considered invalid for billing of collect calls or third number calls or both, by the Level 3.
- F. Billed Number Screening - refers to the activity of determining whether a toll billing exception indicator is present for a particular billing number.

- H. Calling Card Validation - refers to the activity of determining whether a particular calling card number exists as stated or otherwise provided by a caller.
- J. Billing number information - information about billing number or Calling Card number as assigned by BellSouth and toll billing exception indicator provided to BellSouth by the Level 3.

III. RESPONSIBILITIES OF PARTIES

- A. BellSouth will include billing number information associated with resold exchange lines or SPNP arrangements in its LIDB. Level 3 will request any toll billing exceptions via the Local Service Request (LSR) form used to order resold exchange lines, or the SPNP service request form used to order SPNP arrangements.
- B. Under normal operating conditions, BellSouth shall include the billing number information in its LIDB upon completion of the service order establishing either the resold local exchange service or the SPNP arrangement, provided that BellSouth shall not be held responsible for any delay or failure in performance to the extent such delay or failure is caused by circumstances or conditions beyond BellSouth's reasonable control. BellSouth will store in its LIDB an unlimited volume of the working telephone numbers associated with either the resold local exchange lines or the SPNP arrangements. For resold local exchange lines or for SPNP arrangements, BellSouth will issue line-based calling cards only in the name of Level 3. BellSouth will not issue line-based calling cards in the name of Level 3's individual end users. In the event that Level 3 wants to include calling card numbers assigned by the Level 3 in the BellSouth LIDB, a separate agreement is required.
- C. BellSouth will provide responses to on-line, call-by-call queries to the stored information for the specific purposes listed in the next paragraph.
- D. BellSouth is authorized to use the billing number information to perform the following functions for authorized users on an on-line basis:
 - 1. Validate a 14 digit Calling Card number where the first 10 digits are a line number or special billing number assigned by BellSouth, and where the last four digits (PIN) are a security code assigned by BellSouth.
 - 2. Determine whether the Level 3 has identified the billing number as one which should not be billed for collect or third number calls, or both.

RAO Hosting

1. RAO Hosting, Calling Card and Third Number Settlement System (CATS) and Non-Intercompany Settlement System (NICS) services provided to Level 3 by BellSouth will be in accordance with the methods and practices regularly adopted and applied by BellSouth to its own operations during the term of this Agreement, including such revisions as may be made from time to time by BellSouth.
2. Level 3 shall furnish all relevant information required by BellSouth for the provision of RAO Hosting, CATS and NICS.
3. Applicable compensation amounts will be billed by BellSouth to Level 3 on a monthly basis in arrears. Amounts due from one Party to the other (excluding adjustments) are payable within thirty (30) days of receipt of the billing statement.
4. Level 3 must have its own unique RAO code. Requests for establishment of RAO status where BellSouth is the selected Centralized Message Distribution System (CMDS) interfacing host, require written notification from Level 3 to the BellSouth RAO Hosting coordinator at least eight (8) weeks prior to the proposed effective date. The proposed effective date will be mutually agreed upon between the Parties with consideration given to time necessary for the completion of required Telcordia (formerly BellCore) functions. BellSouth will request the assignment of an RAO code from its connecting contractor, currently Telcordia (formerly BellCore), on behalf of Level 3 and will coordinate all associated conversion activities.
5. BellSouth will receive messages from Level 3 that are to be processed by BellSouth, another LEC or CLEC in the BellSouth region or a LEC outside the BellSouth region.
6. BellSouth will perform invoice sequence checking, standard EMI format editing, and balancing of message data with the EMI trailer record counts on all data received from Level 3.
7. All data received from Level 3 that is to be processed or billed by another LEC or CLEC within the BellSouth region will be distributed to that LEC or CLEC in accordance with the agreement(s) which may be in effect between BellSouth and the involved LEC or CLEC.
8. All data received from Level 3 that is to be placed on the CMDS network for distribution outside the BellSouth region will be handled in accordance with the agreement(s) which may be in effect between BellSouth and its connecting contractor (currently Telcordia (formerly BellCore)).

9. BellSouth will receive messages from the CMDS network that are destined to be processed by Level 3 and will forward them to Level 3 on a daily basis.
10. Transmission of message data between BellSouth and Level 3 will be via CONNECT:Direct.
11. All messages and related data exchanged between BellSouth and Level 3 will be formatted in accordance with accepted industry standards for EMI formatted records and packed between appropriate EMI header and trailer records, also in accordance with accepted industry standards.
12. Level 3 will ensure that the recorded message detail necessary to recreate files provided to BellSouth will be maintained for back-up purposes for a period of three (3) calendar months beyond the related message dates.
13. Should it become necessary for Level 3 to send data to BellSouth more than sixty (60) days past the message date(s), Level 3 will notify BellSouth in advance of the transmission of the data. If there will be impacts outside the BellSouth region, BellSouth will work with its connecting contractor and Level 3 to notify all affected Parties.
14. In the event that data to be exchanged between the two Parties should become lost or destroyed, both Parties will work together to determine the source of the problem. Once the cause of the problem has been jointly determined and the responsible Party (BellSouth or Level 3) identified and agreed to, the company responsible for creating the data (BellSouth or Level 3) will make every effort to have the affected data restored and retransmitted. If the data cannot be retrieved, the responsible Party will be liable to the other Party for any resulting lost revenue. Lost revenue may be a combination of revenues that could not be billed to the end users and associated access revenues. Both Parties will work together to estimate the revenue amount based upon historical data through a method mutually agreed upon. The resulting estimated revenue loss will be paid by the responsible Party to the other Party within three (3) calendar months of the date of problem resolution, or as mutually agreed upon by the Parties.
15. Should an error be detected by the EMI format edits performed by BellSouth on data received from Level 3, the entire pack containing the affected data will not be processed by BellSouth. BellSouth will notify Level 3 of the error condition. Level 3 will correct the error(s) and will resend the entire pack to BellSouth for processing. In the event that an out-of-sequence condition occurs on subsequent packs, Level 3 will resend these packs to BellSouth after the pack containing the error has been successfully reprocessed by BellSouth.

16. In association with message distribution service, BellSouth will provide Level 3 with associated intercompany settlements reports (CATS and NICS) as appropriate.
17. In no case shall either Party be liable to the other for any direct or consequential damages incurred as a result of the obligations set out in this agreement.
18. RAO Compensation
- 18.1 Rates for message distribution service provided by BellSouth for Level 3 are as set forth in Exhibit A to this Attachment.
- 18.2 Rates for data transmission associated with message distribution service are as set forth in Exhibit A to this Attachment .
- 18.3 Data circuits (private line or dial-up) will be required between BellSouth and Level 3 for the purpose of data transmission. Where a dedicated line is required, Level 3 will be responsible for ordering the circuit, overseeing its installation and coordinating the installation with BellSouth. Level 3 will also be responsible for any charges associated with this line. Equipment required on the BellSouth end to attach the line to the mainframe computer and to transmit successfully ongoing will be negotiated on a case by case basis. Where a dial-up facility is required, dial circuits will be installed in the BellSouth data center by BellSouth and the associated charges assessed to Level 3. Additionally, all message toll charges associated with the use of the dial circuit by Level 3 will be the responsibility of Level 3. Associated equipment on the BellSouth end, including a modem, will be negotiated on a case by case basis between the Parties.
- 18.4 All equipment, including modems and software, that is required on the Level 3 end for the purpose of data transmission will be the responsibility of Level 3.
19. Intercompany Settlements Messages
- 19.1 This Section addresses the settlement of revenues associated with traffic originated from or billed by Level 3 as a facilities based provider of local exchange telecommunications services outside the BellSouth region. Only traffic that originates in one Bell operating territory and bills in another Bell operating territory is included. Traffic that originates and bills within the same Bell operating territory will be settled on a local basis between Level 3 and the involved company(ies), unless that company is participating in NICS.

- 19.2 Both traffic that originates outside the BellSouth region by Level 3 and is billed within the BellSouth region, and traffic that originates within the BellSouth region and is billed outside the BellSouth region by Level 3, is covered by this Agreement (CATS). Also covered is traffic that either is originated by or billed by Level 3, involves a company other than Level 3, qualifies for inclusion in the CATS settlement, and is not originated or billed within the BellSouth region (NICS).
- 19.3 Once Level 3 is operating within the BellSouth territory, revenues associated with calls originated and billed within the BellSouth region will be settled via Telcordia (formerly BellCore)'s, its successor or assign, NICS system.
- 19.4 BellSouth will receive the monthly NICS reports from Telcordia (formerly BellCore), its successor or assign, on behalf of Level 3. BellSouth will distribute copies of these reports to Level 3 on a monthly basis.
- 19.5 BellSouth will receive the monthly Calling Card and Third Number Settlement System (CATS) reports from Telcordia (formerly BellCore), its successor or assign, on behalf of Level 3. BellSouth will distribute copies of these reports to Level 3 on a monthly basis.
- 19.6 BellSouth will collect the revenue earned by Level 3 from the Bell operating company in whose territory the messages are billed (CATS), less a per message billing and collection fee of five cents (\$0.05), on behalf of Level 3. BellSouth will remit the revenue billed by Level 3 to the Bell operating company in whose territory the messages originated, less a per message billing and collection fee of five cents (\$0.05), on behalf on Level 3. These two amounts will be netted together by BellSouth and the resulting charge or credit issued to Level 3 via a monthly Carrier Access Billing System (CABS) miscellaneous bill.
- 19.7 BellSouth will collect the revenue earned by Level 3 within the BellSouth territory from another CLEC also within the BellSouth territory (NICS) where the messages are billed, less a per message billing and collection fee of five cents (\$0.05), on behalf of Level 3. BellSouth will remit the revenue billed by Level 3 within the BellSouth region to the CLEC also within the BellSouth region, where the messages originated, less a per message billing and collection fee of five cents (\$0.05). These two amounts will be netted together by BellSouth and the resulting charge or credit issued to Level 3 via a monthly Carrier Access Billing System (CABS) miscellaneous bill.

BellSouth and Level 3 agree that monthly netted amounts of less than fifty dollars (\$50.00) will not be settled.

Optional Daily Usage File

1. Upon written request from Level 3, BellSouth will provide the Optional Daily Usage File (ODUF) service to Level 3 pursuant to the terms and conditions set forth in this section.
2. Level 3 shall furnish all relevant information required by BellSouth for the provision of the Optional Daily Usage File.
3. The Optional Daily Usage Feed will contain billable messages that were carried over the BellSouth Network and processed in the BellSouth Billing System, but billed to a Level 3 customer.

Charges for delivery of the Optional Daily Usage File will appear on Level 3s' monthly bills. The charges are as set forth in Exhibit A to this Attachment.

4. The Optional Daily Usage Feed will contain both rated and unrated messages. All messages will be in the standard Alliance for Telecommunications Industry Solutions (ATIS) EMI record format.
5. Messages that error in Level 3's billing system will be the responsibility of Level 3. If, however, Level 3 should encounter significant volumes of errored messages that prevent processing by Level 3 within its systems, BellSouth will work with the to determine the source of the errors and the appropriate resolution.
6. The following specifications shall apply to the Optional Daily Usage Feed.

6.1 Usage To Be Transmitted

6.1.1 The following messages recorded by BellSouth will be transmitted to Level 3:

- Message recording for per use/per activation type services (examples: Three Way Calling, Verify, Interrupt, Call Return, ETC.)
- Measured billable Local
- Directory Assistance messages
- IntraLATA Toll
- WATS & 800 Service
- N11

- Information Service Provider Messages
 - Operator Services Messages
 - Operator Services Message Attempted Calls (UNE only)
 - Credit/Cancel Records
 - Usage for Voice Mail Message Service
- 6.1.2 Rated Incollects (originated in BellSouth and from other companies) can also be on Optional Daily Usage File. Rated Incollects will be intermingled with BellSouth recorded rated and unrated usage. Rated Incollects will not be packed separately.
- 6.1.3 BellSouth will perform duplicate record checks on records processed to Optional Daily Usage File. Any duplicate messages detected will be deleted and not sent to Level 3.
- 6.1.4 In the event that Level 3 detects a duplicate on Optional Daily Usage File they receive from BellSouth, Level 3 will drop the duplicate message (Level 3 will not return the duplicate to BellSouth).
- 6.2 Physical File Characteristics
- 6.2.1 The Optional Daily Usage File will be distributed to Level 3 via an agreed medium with CONNECT:Direct being the preferred transport method. The Daily Usage Feed will be a variable block format (2476) with an LRECL of 2472. The data on the Daily Usage Feed will be in a non-compacted EMI format (175 byte format plus modules). It will be created on a daily basis (Monday through Friday except holidays). Details such as dataset name and delivery schedule will be addressed during negotiations of the distribution medium. There will be a maximum of one dataset per workday per OCN.
- 6.2.2 Data circuits (private line or dial-up) may be required between BellSouth and Level 3 for the purpose of data transmission. Where a dedicated line is required, Level 3 will be responsible for ordering the circuit, overseeing its installation and coordinating the installation with BellSouth. Level 3 will also be responsible for any charges associated with this line. Equipment required on the BellSouth end to attach the line to the mainframe computer and to transmit successfully ongoing will be negotiated on a case by case basis. Where a dial-up facility is required, dial circuits will be installed in the BellSouth data center by BellSouth and the associated charges assessed to Level 3. Additionally, all message toll charges associated with the use of the dial circuit by Level 3 will be the responsibility of Level 3. Associated equipment on the BellSouth end, including a modem, will be negotiated on a case by case basis between the parties.

All equipment, including modems and software, that is required on Level 3 end for the purpose of data transmission will be the responsibility of Level 3.

6.3 Packing Specifications

6.3.1 A pack will contain a minimum of one message record or a maximum of 99,999 message records plus a pack header record and a pack trailer record. One transmission can contain a maximum of 99 packs and a minimum of one pack.

6.3.2 The OCN, From RAO, and Invoice Number will control the invoice sequencing. The From RAO will be used to identify to Level 3 which BellSouth RAO that is sending the message. BellSouth and Level 3 will use the invoice sequencing to control data exchange. BellSouth will be notified of sequence failures identified by Level 3 and resend the data as appropriate.

THE DATA WILL BE PACKED USING ATIS EMI RECORDS.

6.4 Pack Rejection

6.4.1 Level 3 will notify BellSouth within one business day of rejected packs (via the mutually agreed medium). Packs could be rejected because of pack sequencing discrepancies or a critical edit failure on the Pack Header or Pack Trailer records (i.e. out-of-balance condition on grand totals, invalid data populated). Standard ATIS EMI Error Codes will be used. Level 3 will not be required to return the actual rejected data to BellSouth. Rejected packs will be corrected and retransmitted to Level 3 by BellSouth.

6.5 Control Data

Level 3 will send one confirmation record per pack that is received from BellSouth. This confirmation record will indicate Level 3 received the pack and the acceptance or rejection of the pack. Pack Status Code(s) will be populated using standard ATIS EMI error codes for packs that were rejected by Level 3 for reasons stated in the above section.

6.6 Testing

6.6.1 Upon request from Level 3, BellSouth shall send test files to Level 3 for the Optional Daily Usage File. The parties agree to review and discuss the file's content and/or format. For testing of usage results, BellSouth shall request that Level 3 set up a production (LIVE) file. The live test may consist of Level 3's employees making test calls for the types of services Level 3 requests on the Optional Daily Usage File. These test calls are logged by Level 3, and the logs are provided to BellSouth. These

logs will be used to verify the files. Testing will be completed within 30 calendar days from the date on which the initial test file was sent.

Enhanced Optional Daily Usage File

1. Upon written request from Level 3, BellSouth will provide the Enhanced Optional Daily Usage File (EODUF) service to Level 3 pursuant to the terms and conditions set forth in this section. EODUF will only be sent to existing ODUF subscribers who request the EODUF option.
2. The Level 3 shall furnish all relevant information required by BellSouth for the provision of the Enhanced Optional Daily Usage File.
3. The Enhanced Optional Daily Usage File (EODUF) will provide usage data for local calls originating from resold Flat Rate Business and Residential Lines.
4. Charges for delivery of the Enhanced Optional Daily Usage File will appear on Level 3s' monthly bills. The charges are as set forth in Exhibit A to this Attachment.
5. All messages will be in the standard Alliance for Telecommunications Industry Solutions (ATIS) EMI record format.
6. Messages that error in the billing system of Level 3 will be the responsibility of Level 3. If, however, Level 3 should encounter significant volumes of errored messages that prevent processing by Level 3 within its systems, BellSouth will work with Level 3 to determine the source of the errors and the appropriate resolution.
7. The following specifications shall apply to the Optional Daily Usage Feed.

7.1 Usage To Be Transmitted

- 7.1.1 The following messages recorded by BellSouth will be transmitted to Level 3:

Customer usage data for flat rated local call originating from Level 3's end user lines (1FB or 1FR). The EODUF record for flat rate messages will include:

Date of Call
From Number
To Number
Connect Time
Conversation Time
Method of Recording
From RAO
Rate Class
Message Type

Billing Indicators
Bill to Number

- 7.1.2 BellSouth will perform duplicate record checks on EODUF records processed to Optional Daily Usage File. Any duplicate messages detected will be deleted and not sent to Level 3.
- 7.1.3 In the event that Level 3 detects a duplicate on Enhanced Optional Daily Usage File they receive from BellSouth, Level 3 will drop the duplicate message (Level 3 will not return the duplicate to BellSouth).

7.2 Physical File Characteristics

- 7.2.1 The Enhanced Optional Daily Usage Feed will be distributed to Level 3 over their existing Optional Daily Usage File (ODUF) feed. The EODUF messages will be intermingled among Level 3's Optional Daily Usage File (ODUF) messages. The EODUF will be a variable block format (2476) with an LRECL of 2472. The data on the EODUF will be in a non-compacted EMI format (175 byte format plus modules). It will be created on a daily basis (Monday through Friday except holidays).
- 7.2.2 Data circuits (private line or dial-up) may be required between BellSouth and Level 3 for the purpose of data transmission. Where a dedicated line is required, Level 3 will be responsible for ordering the circuit, overseeing its installation and coordinating the installation with BellSouth. Level 3 will also be responsible for any charges associated with this line. Equipment required on the BellSouth end to attach the line to the mainframe computer and to transmit successfully ongoing will be negotiated on a case by case basis. Where a dial-up facility is required, dial circuits will be installed in the BellSouth data center by BellSouth and the associated charges assessed to Level 3. Additionally, all message toll charges associated with the use of the dial circuit by Level 3 will be the responsibility of Level 3. Associated equipment on the BellSouth end, including a modem, will be negotiated on a case by case basis between the parties. All equipment, including modems and software, that is required on Level 3's end for the purpose of data transmission will be the responsibility of Level 3.

7.3 Packing Specifications

- 7.3.1 A pack will contain a minimum of one message record or a maximum of 99,999 message records plus a pack header record and a pack trailer record. One transmission can contain a maximum of 99 packs and a minimum of one pack.
- 7.3.2 The Operating Company Number (OCN), From Revenue Accounting Office (RAO), and Invoice Number will control the invoice sequencing. The From RAO will be used

to identify to Level 3 which BellSouth RAO that is sending the message. BellSouth and Level 3 will use the invoice sequencing to control data exchange. BellSouth will be notified of sequence failures identified by Level 3 and resend the data as appropriate.

THE DATA WILL BE PACKED USING ATIS EMI RECORDS.

CALLING NAME DELIVERY (CNAM) DATABASE SERVICES

1. DEFINITIONS

For the purpose of this Attachment, the following terms shall be defined as:

CALLING NAME DELIVERY DATABASE SERVICE (CNAM) - The ability to associate a name with the calling party number, allowing the end user subscriber (to which a call is being terminated) to view the calling party's name before the call is answered. This service also provides Level 3 the opportunity to load and store its subscriber names in the BellSouth CNAM SCPs.

CALLING PARTY NUMBER (CPN) - The number of the calling party that is delivered to the terminating switch using common channel signaling system 7 (CCS7) technology, and that is contained in the Initial Address Message (IAM) portion of the CCS7 call setup.

COMMON CHANNEL SIGNALING SYSTEM 7 (CCS7) - A network signaling technology in which all signaling information between two or more nodes is transmitted over high-speed data links, rather than over voice circuits.

SERVICE CONTROL POINTs (SCPs) - The real-time data base systems that contain the names to be provided in response to queries received from CNAM SSPs.

SERVICE MANAGEMENT SYSTEM (SMS) - The main operations support system of CNAM DATABASE SERVICE. CNAM records are loaded into the SMS, which in turn downloads into the CNAM SCP.

SERVICE SWITCHING POINTs (SSPs) - Features of computerized switches in the telephone network that determine that a terminating line has subscribed to CNAM service, and then communicate with CNAM SCPs in order to provide the name associated with the calling party number.

SUBSYSTEM NUMBER (SSN) - The address used in the Signaling Connection Control Part (SCCP) layer of the SS7 protocol to designate an application at an end signaling point. A SSN for CNAM at the end office designates the CNAM application within the end office. BellSouth uses the CNAM SSN of 232.

2. ATTACHMENT

- 2.1 This Attachment contains the terms and conditions where BellSouth will provide to Level 3 access to the BellSouth CNAM SCP for query or record storage purposes.

Level 3 shall submit to BellSouth a notice of its intent to access and utilize BellSouth CNAM Database Services pursuant to the terms and conditions of this Attachment. Said notice shall be in writing, no less than 60 days prior to Level 3's access to BellSouth's CNAM Database Services and shall be addressed to Level 3's Account Manager.

3. PHYSICAL CONNECTION AND COMPENSATION

- 3.1 BellSouth's provision of CNAM Database Services to Level 3 requires interconnection from Level 3 to BellSouth CNAM Service Control Points (SCPs). Such interconnections shall be established pursuant to Attachment 3 of this Agreement. The appropriate charge for access to and use of the BellSouth CNAM Database service shall be as set forth in this Attachment.
- 3.2 In order to formulate a CNAM query to be sent to the BellSouth CNAM SCP, Level 3 shall provide its own CNAM SSP. Level 3's CNAM SSPs must be compliant with TR-NWT-001188, "CLASS Calling Name Delivery Generic Requirements".
- 3.3 If Level 3 elects to access the BellSouth CNAM SCP via a third party CCS7 transport provider, the third party CCS7 provider shall interconnect with the BellSouth CCS7 network according to BellSouth's Common Channel Signaling Interconnection Guidelines and Telcordia (formerly BellCore)'s CCS Network Interface Specification document, TR-TSV-000905. In addition, the third party provider shall establish CCS7 interconnection at the BellSouth Local Signal Transfer Points (LSTPs) serving the BellSouth CNAM SCPs that Level 3 desires to query.
- 3.4 Out-Of-Region Customers. If the customer queries the BellSouth CNAM SCP via a third party national SS7 transport provider, the third party SS7 provider shall interconnect with the BellSouth CCS7 network according to BellSouth's Common Channel Signaling Interconnection Guidelines and Bellcore's CCS Network Interface Specification document, TR-TSV-000905. In addition, the third party provider shall establish SS7 interconnection at one or more of the BellSouth Gateway Signal Transfer Points (STPs). The payment of all costs associated with the transport of SS7 signals via a third party will be established by mutual agreement of the parties and writing shall, by this reference become an integral part of this Agreement.

4. CNAM RECORD INITIAL LOAD AND UPDATES

- 4.1 The mechanism to be used by Level 3 for initial CNAM record load and/or updates shall be determined by mutual agreement. The initial load and all updates shall be provided by Level 3 in the BellSouth specified format and shall contain records for every working telephone number that can originate phone calls. It is the responsibility of Level 3 to provide accurate information to BellSouth on a current basis.

- 4.2 Updates to the SMS shall occur no less than once a week, reflect service order activity affecting either name or telephone number, and involve only record additions, deletions or changes.
- 4.3 Level 3 CNAM records provided for storage in the BellSouth CNAM SCP shall be available, on a SCP query basis only, to all parties querying the BellSouth CNAM SCP. Further, CNAM service shall be provided by each party consistent with state and/or federal regulation.

BELLSOUTH/LEVEL 3 RATES
 ODUF/EODUF/CMDS

RATES BY STATE

DESCRIPTION	USOC	AL	FL	GA	KY	LA	MS	NC	SC	TN
ODUF/EODUF/CMDS										
ODUF: Recording, per message	N/A	\$0.0002	\$0.008	\$0.008	\$0.0008611	\$0.00019	\$0.0001179	\$0.008	\$0.0002862	\$0.008
ODUF: Message Processing, per message	N/A	\$0.0033	\$0.004	\$0.004	\$0.0032357	\$0.0024	\$0.0032089	\$0.004	\$0.0032344	\$0.004
EODUF: Message Processing, per message	N/A	\$0.004	\$0.004	\$0.004	\$0.004	\$0.004	\$0.004	\$0.004	\$0.004	\$0.004
CMDS: Message Processing, per message	N/A	\$0.004	\$0.004	\$0.004	\$0.004	\$0.004	\$0.004	\$0.004	\$0.004	\$0.004
ODUF: Message Processing, per magnetic tape provisioned	N/A	\$55.19	\$54.95	\$54.95	\$55.68	\$47.30	\$54.62	\$54.95	\$54.72	\$54.95
EODUF: Message Processing, per magnetic tape provisioned	N/A	\$47.30	\$47.30	\$47.30	\$47.30	\$47.30	\$47.30	\$47.30	\$47.30	\$47.30
ODUF: Data Transmission (CONNECT:DIRECT), per message	N/A	\$0.00004	\$0.001	\$0.001	\$0.0000365	\$0.00003	\$0.0000354	\$0.001	\$0.0000357	\$0.001
EODUF: Data Transmission (CONNECT:DIRECT), per message	N/A	\$0.0000364	\$0.0000364	\$0.0000364	\$0.0000364	\$0.0000364	\$0.0000364	\$0.0000364	\$0.0000364	\$0.0000364

* Volume and term arrangements are also available.

NOTES:

If no rate is identified in the contract, the rate for the specific service or function will be as set forth in applicable BellSouth tariff or as negotiated by the parties upon request by either party.

Attachment 2
Network Elements and Other Services

TABLE OF CONTENTS

1. INTRODUCTION..... 3

2. UNBUNDLED LOOPS, INTEGRATED DIGITAL LOOP CARRIERS, NETWORK INTERFACES
DEVICE, UNBUNDLED LOOP CONCENTRATION (ULC) SYSTEM, SUB LOOPS AND DARK FIBER. 5

3. SWITCHING 18

4. ENHANCED EXTENDED LINK (EEL)ERROR! BOOKMARK NOT DEFINED.

5. PORT/LOOP COMBINATIONS..... 33

6. TRANSPORT AND DARK FIBER..... 34

7. BELLSOUTH SWA 8XX TOLL FREE DIALING TEN DIGIT SCREENING SERVICE..... 44

8. LINE INFORMATION DATABASE (LIDB)..... 46

9. SIGNALING 49

10. OPERATOR CALL PROCESSING, INWARD OPERATOR SERVICES AND DIRECTORY
ASSISTANCE SERVICES 58

11. CALLING NAME (CNAM) DATABASE SERVICE..... 65

12. BASIC 911 AND E911 67

13. TRUE-UP 68

LIDB Storage Agreement.....Exhibit

A

CNAM Database Services.....Exhibit

B

Rates.....Exhibit

C

ACCESS TO NETWORK ELEMENTS AND OTHER SERVICES

1. Introduction

- 1.1. This Attachment sets forth the unbundled network elements and combinations of unbundled network elements that BellSouth agrees to offer to Level 3 in accordance with its obligations under Section 251(c)(3) of the Act. The specific terms and conditions that apply to the unbundled network elements are described below in this Attachment 2. The price for each unbundled network element and combination of unbundled Network Elements is set forth in Exhibit A of this Agreement.
- 1.2. For purposes of this Agreement, “Network Element” is defined to mean a facility or equipment provided by BellSouth on an unbundled basis as is used by the CLEC in the provision of a telecommunications service. These unbundled network elements will be consistent with the requirements of 47 C.F.R. § 51.319. For purposes of this Agreement, combinations of Network Elements shall be referred to as “Combinations.”
 - 1.2.1. Intentionally left blank.
 - 1.2.2. Except upon request by Level 3, BellSouth shall not separate requested network elements that BellSouth currently combines.
 - 1.2.2.1. Unless otherwise ordered by an appropriate state or federal regulatory agency, currently combined Network Elements are defined as elements that are already combined within BellSouth's network to a given location.
- 1.3. BellSouth shall, upon request of Level 3, and to the extent technically feasible, provide to Level 3 access to its network elements for the provision of Level 3’s telecommunications service. If no rate is identified in the contract for a specific service or function that is identified in the Agreement, the rate for the specific service or function will be as negotiated by the Parties upon request by either Party.
- 1.4. Level 3 may purchase network elements and other services from BellSouth for the purpose of combining such network elements in any manner Level 3 chooses to provide telecommunication services to its intended users, including recreating existing BellSouth services. With the exception of the sub-loop elements which are located outside of the central office, BellSouth shall deliver the individual network elements purchased by Level 3 for combining to the designated Level 3 collocation space. The network elements shall be provided as set forth in this Attachment.

- 1.5. Subject to applicable and effective FCC Rules and Orders as well as effective State Commission Orders, BellSouth will offer combinations of network elements pursuant to such orders. BellSouth will provide the following combined network components or elements for purchase by Level 3. The rate of the following combined network components or elements is the sum of the individual component or element prices as set forth in this Attachment. Order Coordination as defined in Section 2 of Attachment 2 of this Agreement is available for each of these combinations:
- SL2 loop and cross connect
 - Port and cross connect
 - Port and cross connect and common (shared) transport
 - Port and vertical features
 - SL2 Loop with loop concentration
 - Port and common (shared) transport
 - SL2 Loop and LNP
 - SL1 loop and cross connect
- 1.6. BellSouth shall comply with the requirements as set forth in the technical references within Attachment 2 to the extent that they are consistent with the greater of BellSouth's actual performance or applicable industry standards.
- 1.7. In the event that any effective legislative, regulatory, judicial or other legal action modifies or redefines the "Network Elements" in a manner which materially affects the terms of this Attachment or the Network Elements and/or prices set forth herein, either Party may, on thirty (30) days written notice, require renegotiation of such terms, and the Parties shall renegotiate in good faith such new terms in accordance with such legislative, regulatory, judicial or other legal action. In the event such new terms are not renegotiated within ninety (90) days after the notice for renegotiation, either Party may petition the Commission for resolution of the dispute between the Parties. Each Party reserves the right to seek judicial review of any Commission ruling concerning this Attachment.
- 1.8. Level 3 will adopt and adhere to the standards contained in the applicable CLEC Work Center Operational Understanding Agreement regarding maintenance and installation of service as in effect on the date of execution of this Agreement.
- 1.9. Standards for Network Elements
- 1.9.1 BellSouth shall comply with the requirements set forth in the technical references, as well as any performance or other requirements identified in this Agreement, to the extent that they are consistent with the greater of BellSouth's actual performance or applicable industry standards.
- 1.9.2 If one or more of the requirements set forth in this Agreement are in conflict, the parties shall mutually agree on which requirement shall apply. If the parties cannot

reach agreement, the dispute resolution process set forth in Section 12 of the General Terms and Conditions of this Agreement, incorporated herein by this reference, shall apply.

2. Unbundled Loops, Integrated Digital Loop Carriers, Network Interfaces Device, Unbundled Loop Concentration (ULC) System, Sub loops, Dark Fiber, and Line Sharing

All of the negotiated rates, terms and conditions set forth in this Section pertain to the provision of unbundled loops.

2.1 Unbundled Loops

2.1.1 Definition

2.1.2 The local loop network element (“Loop(s)”) is defined as a transmission facility between a distribution frame (or its equivalent) in BellSouth’s central office and the loop demarcation point at an end-user customer premises, including inside wire owned by BellSouth. The local loop network element includes all features, functions, and capabilities of the transmission facilities, including dark fiber and attached electronics (except those used for the provision of advanced services, such as Digital Subscriber Line Access Multiplexers) and line conditioning. The loop shall include the use of all test access functionality, including without limitation, smart jacks, for both voice and data.

2.1.3 The provisioning of service to a CLEC will require cross-office cabling and cross-connections within the central office to connect the loop to a local switch or to other transmission equipment in collocation space.

2.1.4 BellSouth Order Coordination referenced in Attachment 2 includes two types: “Order Coordination” and “Order Coordination - Time Specific.”

2.1.5 “Order Coordination” (OC) refers to standard BellSouth service order coordination involving SL2 voice loops and all digital loops. Order coordination for physical conversions will be scheduled at BellSouth’s discretion during normal working hours (location time) on the committed due date, where BellSouth provides Level 3 prior notice of the due date.

2.1.6 “Order Coordination – Time Specific” (OC-TS) refers to service order coordination in which Level 3 requests a specific time for a service order conversion to take place. Loops on a single service order of 14 or more loops will be provisioned on a project basis. This is a chargeable option for any coordinated order and is billed in addition to the OC charge. Level 3 may specify a time between 9:00 a.m. and 4:00 p.m. (location time) Monday through Friday (excluding holidays). If Level 3 specifies a time outside this window, or selects a time or quantity of loops that requires BellSouth technicians

- to work outside normal work hours, overtime charges will apply in addition to the OC and OC-TS charges. Overtime charges will be applied according to actual costs based on type of force group required to perform the work, overtime hours worked and any special circumstances.
- 2.1.7 Where facilities are available (as determined on a nondiscriminatory basis), BellSouth will install loops within a 5-7 business days interval. For orders of 14 or more loops, the installation will be handled on a project basis and the intervals will be set by the BellSouth project manager for that order. Some loops require a Service Inquiry (SI) to determine if facilities are available prior to issuing the order. The interval for the SI process is separate from the installation interval. For expedite requests by Level 3, expedite charges will apply for intervals less than 5 days. Charges associated with expedite requests are set forth in Exhibit C. If Level 3 cancels an order for loops or any other Network Elements, BellSouth shall be entitled to recover its reasonable and demonstrable costs incurred in providing that element or service up to the time of cancellation as set forth in BellSouth's FCC No.4 Tariff, Section 5.4.
- 2.1.8 If Level 3 modifies an order after being sent a Firm Order Confirmation (FOC) from BellSouth, any reasonable and demonstrable costs incurred by BellSouth to accommodate the modification will be reimbursed by Level 3.
- 2.1.9 BellSouth will offer Unbundled Voice Loops (UVL) on a nondiscriminatory basis in two different service levels - Service Level One (SL1) and Service Level Two (SL2).
- 2.1.10 SL1 loops will be non-designed, will not have test points, and will not come with any Order Coordination (OC) or engineering information/circuit make-up data. Upon issuance of an order in the service order system, SL1 loops will be activated on the due date in the same manner and time frames that BellSouth normally activates POTS-type loops for its customers. If Level 3 requests work to be done for SL1s that requires BellSouth technicians to work outside normal work hours (location time), overtime charges will be applied according to actual costs based on type of force group required to perform the work, overtime hours worked and any special circumstances.
- 2.1.11 SL2 loops shall have test points, with or without conditioning, will be designed with a design layout record provided to Level 3, and will be provided with OC. The OC feature will allow Level 3 to coordinate the installation of the loop with the disconnect of an existing customer's service and/or number portability service. In these cases, BellSouth will perform the order conversion with standard order coordination at its discretion during normal work hours.
- 2.1.12 BellSouth will also offer Unbundled Digital Loops (UDL) on a nondiscriminatory basis. They will be designed, will be provisioned with test points (where appropriate), and will come standard with Order Coordination and a Design Layout Record (DLR).

- 2.1.13 As a chargeable option on all loops except UVL-SL1 and Unbundled Copper Loop (UCL), BellSouth will offer Order Coordination - Time Specific (OC-TS). This will allow Level 3 the ability to specify the time that the coordinated conversion takes place. The OC-TS charge for orders due on the same day at the same location will be applied on a per Local Service Request (LSR) basis.
- 2.1.14 Level 3 will be responsible for testing and isolating troubles on the loops. Once Level 3 has isolated a trouble to the BellSouth provided loop, Level 3 will issue a trouble report to BellSouth on the loop. BellSouth will take the actions necessary to repair the loop if a trouble actually exists. BellSouth will repair these loops in the same time frames that BellSouth repairs similarly situated loops to its customers.
- 2.1.15 If Level 3 reports a trouble on SL1 loops and no trouble actually exists, BellSouth will charge Level 3 as specified in BellSouth's FCC No.1 Tariff, Section 13, for any dispatching and testing (both inside and outside the CO) required by BellSouth in order to confirm the loop's working status.
- 2.1.16 If Level 3 reports a trouble on SL2 loops and no trouble actually exists, BellSouth will charge Level 3 as specified in BellSouth's FCC No.1 Tariff, Section 13, for any dispatching and testing (outside the CO) required by BellSouth in order to confirm the loop's working status.
- 2.1.17 In addition to the UVLs and UDLs, BellSouth shall make available an UCL on a nondiscriminatory basis. The UCL will be a copper twisted pair loop that is unencumbered by any intervening equipment (e.g., filters, load coils, range extenders, digital loop carrier, or repeaters). The UCL will be offered in two versions - Short and Long. A short UCL (18 kft or less) will be provisioned according to Resistance Design parameters. The long UCL (beyond 18kft) will be used when a CLEC wants to condition copper loops longer than 18kft by removing load coils and other intervening equipment. BST will only ensure electrical continuity and balance relative to tip and ring on UCLs.
- 2.1.18 The UCL will be a designed circuit, with or without conditioning, provisioned with a test point and come standard with a DLR. OC will be offered as a chargeable option on all UCL loops. Order Coordination – Time Specific (OC-TS) will not be offered on UCLs.
- 2.1.19 The UCL is a dry cooper loop and is not intended to support any particular telecommunications service. Level 3 may use the UCL loop for a variety of services, including xDSL (e.g., ADSL and HDSL) services, by attaching appropriate terminal equipment of Level 3's choosing. Level 3 will determine the type of service that will be provided over the loop.

- 2.1.20 Because the UCL loop shall be an unbundled loop offering that is separate and distinct from BellSouth's ADSL and HDSL capable loop offerings, CLEC agrees that BellSouth's UCL loop will not be held to the service level and performance expectations that apply to its ADSL and HDSL unbundled loop offerings. BellSouth shall only be obligated to maintain copper continuity and provide balance relative to tip and ring on UCL loops.
- 2.1.21 The UCL loop shall be provided to CLEC in accordance with BellSouth's Technical Reference 73600.
- 2.1.22 Technical Requirements
- 2.1.22.1 To the extent available within BellSouth's Network at a particular location, BellSouth will offer loops capable of supporting telecommunications services such as: POTS, Centrex, basic rate ISDN, analog PBX, voice grade private line, ADSL, HDSL, DS1, DS3, and digital data (up to 64 kb/s). If a requested loop type is not available, then the CLEC can use the Special Construction process to request that BellSouth place facilities or otherwise modify facilities in order to meet Level 3's request.
- 2.1.22.2 Level 3 will be responsible for providing BellSouth with a Service Profile Identifier (SPID) associated with a particular ISDN-capable loop and end user. With the SPID, BellSouth will be able to adequately test the circuit and ensure that it properly supports ISDN service.
- 2.1.22.3 The loop will support the transmission, signaling, performance and interface requirements of the services described in 2.1.3 above. It is recognized that the requirements of different services are different, and that a number of types or grades of loops are required to support these services. Services provided over the loop by Level 3 will be consistent with industry standards and BellSouth's TR73600.
- 2.1.22.4 Level 3 may utilize the unbundled loops to provide any telecommunication service it wishes. However, BellSouth will only provision, maintain and repair the loops to the standards that are consistent with the type of loop ordered. For example, if Level 3 orders an ISDN-capable loop but wants to use the loop for a service other than ISDN, BellSouth will only support that the loop is capable of providing ISDN service. For non-service specific loops (e.g. UCL, loops modified by Level 3 using the Special Construction process), BellSouth will only support that the loop has copper continuity and balanced tip-and-ring.
- 2.1.22.5 In some instances, Level 3 will require access to a copper twisted pair loop unfettered by any intervening equipment (e.g., filters, load coils, range extenders, etc.), so that Level 3 can use the loop for a variety of services by attaching appropriate terminal equipment at the ends. Level 3 will determine the type of service that will be provided over the loop. In some cases, Level 3 may be required to pay additional charges for the removal of certain types of equipment. If conditioning is required to make these

loops available, BellSouth's Unbundled Loop Modification ("ULM") process will be utilized at the rates set forth in Exhibit C.

- 2.1.22.6 In cases in which Level 3 has requested that BellSouth remove equipment from the BellSouth loop, and that loop no longer meets the appropriate technical specifications for the original loop type, BellSouth will no longer be expected to maintain and repair the loop to the standards specified for that loop type in the TR73600 and other standards referenced in this Agreement. Any loop modified beyond the appropriate technical specifications must be ordered as a UCL, and BellSouth will only support that these loops provide electrical continuity and balance relative to tip-and-ring.
- 2.1.22.7 The loop shall be provided to Level 3 in accordance with BellSouth's TR73600 Unbundled Local Loop Technical Specification and applicable industry standard technical references.

2.2 Loop Conditioning

- 2.2.1 Subject to applicable and effective FCC rules and orders, BellSouth shall condition loops pursuant to the ULM process described in this Section 2.2 on a nondiscriminatory basis, as requested by Level 3, whether or not BellSouth offers advanced services to the End User on that loop.
- 2.2.2 Loop conditioning (ULM) is defined as the removal from the loop of any devices that may diminish the capability of the loop to deliver high-speed switched wireline telecommunications capability, including xDSL service. Such devices include, but are not limited to, bridge taps, low pass filters, and range extenders.
- 2.2.3 BellSouth shall recover the cost of line conditioning requested by Level 3 through a recurring charge and/or nonrecurring charge(s) in accordance with the FCC's forward-looking pricing principles promulgated pursuant to section 252 (d) (1) of the Act and in compliance with FCC Rule 52.507 (e). The prices for Loop Conditioning shall be as set forth in Exhibit C. The prices identified are interim in nature and shall apply only until such time as the Commission establishes prices for Loop Conditioning in any final order. At such time as a final order is issued, the Parties shall "true up" any amounts paid for Loop Conditioning back to the Effective Date of this Agreement, as if Level 3 had purchased all Loop Conditioning at the Commission-established rates starting on that Effective Date.

2.3 Integrated Digital Loop Carriers

- 2.3.1 Where BellSouth uses Integrated Digital Loop Carrier (IDLC) systems to provide the local loop and BellSouth has a suitable alternate facility available, BellSouth will make arrangements to permit Level 3 to order a contiguous local loop. To the extent it is technically feasible, these arrangements will provide Level 3 with the capability to serve end users at a level that is at parity with the level of service BellSouth provides

its customers. If no alternate facility is available or if a subloop cannot be made available in the context of that order, BellSouth will utilize its Special Construction (SC) process to determine the additional costs required to provision the loop facilities. Level 3 will then have the option of paying the one-time nondiscriminatory SC rates (vis-à-vis other carriers and BellSouth end users) to place the loop facilities or Level 3 may choose some other method of providing service to the end-user (e.g., Resale, private facilities, etc.).

2.4 Network Interface Device

2.4.1 Definition

The NID is defined as any means of interconnection of end-user customer premises wiring to BellSouth's distribution plant, such as a cross-connect device used for that purpose. The NID is a single-line termination device or that portion of a multiple-line termination device required to terminate a single line or circuit at the premises. The NID features two independent chambers or divisions that separate the service provider's network from the End User's on-premises wiring. Each chamber or division contains the appropriate connection points or posts to which the service provider and the End User each make their connections. The NID provides a protective ground connection and is capable of terminating cables such as twisted pair cable.

2.4.2. BellSouth shall permit Level 3 to connect Level 3's loop facilities to on-premises wiring through the BellSouth NID or at any other technically feasible point.

2.4.3 Access to Network Interface Device (NID)

2.4.3.1. Due to the wide variety of NIDs utilized by BellSouth (based on subscriber size and environmental considerations), Level 3 may access the on-premises wiring by any of the following means: BellSouth shall allow Level 3 to connect its loops directly to BellSouth's multi-line residential NID enclosures that have additional space and are not used by BellSouth or any other telecommunications carriers to provide service to the premise. Level 3 agrees to install compatible protectors and test jacks and to maintain the protection system and equipment and to indemnify BellSouth pursuant to Section 8 of the General Terms and Conditions of this Agreement.

2.4.3.2. Where an adequate length of on-premises wiring is present and environmental conditions permit, either Party may remove the on-premises wiring from the other Party's NID and connect that wire to that Party's own NID; or

2.4.3.3. Enter the subscriber access chamber or "side" of "dual chamber" NID enclosures for the purpose of extending a connectorized or spliced jumper wire from the on-premises wiring through a suitable "punch-out" hole of such NID enclosures; or

- 2.4.3.4. Request BellSouth to make other rearrangements to the on-premises wiring terminations or terminal enclosure on a time and materials cost basis to be charged to the requesting Party (i.e., Level 3, its agent, the building owner or the subscriber). Such charges will be billed to the requesting Party.
- 2.4.3.5. In no case shall either Party remove or disconnect the other Party's loop facilities from either Party's NIDs, enclosures, or protectors unless: (1) the Commission has expressly permitted the same, (2) the removing Party provides notice to the other Party, and (3) the removing Party appropriately caps off and guards the other Party's loop. In such cases, it shall be the responsibility of the removing Party to ground properly the other Party's loop, maintain the NID, and assume liability for any adverse consequences resulting from its failure to act in accordance with this Section in accordance with applicable Commission decisions.
- 2.4.3.6. In no case shall either Party remove or disconnect ground wires from BellSouth's NIDs, enclosures, or protectors.
- 2.4.3.7. In no case shall either Party remove or disconnect NID modules, protectors, or terminals from BellSouth's NID enclosures.
- 2.4.3.8. Due to the wide variety of NID enclosures and outside plant environments BellSouth will work with Level 3 to develop specific procedures to establish the most effective means of implementing this Section 2.4.3.
- 2.4.4 Technical Requirements
- 2.4.4.1 The NID shall provide an accessible point of interconnection and shall maintain a connection to ground.
- 2.4.4.2 The NID shall be capable of transferring electrical analog or digital signals between the subscriber's inside wiring and the Distribution Media and/or cross connect to Level 3's NID, consistent with the NID's then-current function.
- 2.4.4.3 Where a BellSouth NID exists, it is provided in its "as is" condition. Level 3 may request BellSouth do additional work to the NID in accordance with Section 2.4.3.8.
- 2.4.4.4 When Level 3 deploys its own local loops with respect to multiple-line termination devices, Level 3 shall specify the quantity of NIDs connections that it requires within such device.
- 2.4.5 Interface Requirements
- 2.4.5.1 The NID shall be equal to or better than all of the requirements for NIDs set forth in the applicable industry standard technical references.

2.5 Unbundled Loop Concentration (ULC) System

2.5.1 BellSouth will provide to Level 3 Unbundled Loop Concentration (ULC) on a nondiscriminatory basis. Loop concentration systems in the central office concentrate the signals transmitted over local loops onto a digital loop carrier system. The concentration device is placed inside a BellSouth central office. BellSouth will offer ULC with a TR008 interface or a TR303 interface.

2.5.2 ULC will be offered in two sizes. System A will allow up to 96 BellSouth loops to be concentrated onto multiple DS1s. The high-speed connection from the concentrator will be at the electrical DS1 level and may connect to Level 3 at Level 3's collocation site. System B will allow up to 192 BellSouth loops to be concentrated onto multiple DS1s. System A may be upgraded to a System B. A minimum of two DS1s is required for each system (i.e., System A requires two DS1s and System B would require an additional two DS1s or four in total). All DS1 interfaces will terminate to the CLEC's collocation space. ULC service is offered with or without concentration and with or without protection. A Line Interface element will be required for each loop that is terminated onto the ULC system. Rates for ULC are as set forth in this Attachment.

2.6 Sub-loop Elements

2.6.1 Where facilities permit (as determined on a nondiscriminatory basis) and subject to applicable and effective FCC rules and orders, BellSouth shall offer nondiscriminatory access to its Unbundled Sub Loop (USL), Unbundled Subloop Concentration (USLC) System and Unbundled Network Terminating Wire (UNTW) elements. BellSouth shall provide non-discriminatory access, in accordance with 47 C.F.R § 51.311 and section 251(c) (3) of the Act, to the subloop. On an unbundled basis and pursuant to the following terms and conditions and the rates approved by the Commission and set forth in this Attachment.

2.6.2 Subloop components include but are not limited to the following:

2.6.2.1 Unbundled Sub-Loop Distribution;

2.6.2.2 Unbundled Sub-Loop Concentration/Multiplexing Functionality; and

2.6.2.3 Unbundled Network Terminating Wire; and

2.6.2.4 Unbundled Sub-Loop Feeder.

2.6.3 Unbundled Sub-Loop (distribution facilities)

2.6.3.1 Definition

2.6.3.2 Subject to applicable and effective FCC rules and orders, the unbundled sub-loop distribution facility is dedicated transmission facility that BellSouth provides from a customer's point of demarcation to a BellSouth cross-connect device. The BellSouth cross-connect device may be located within a remote terminal (RT) or a stand-alone cross-box in the field or in the equipment room of a building. There are two offerings available for Unbundled Sub-Loops (USL):

2.6.3.3 Unbundled Sub-Loop Distribution (USL-D) will include the sub-loop facility from the cross-box in the field up to and including the point of demarcation.

2.6.3.4 BellSouth will also provide sub-loop interconnection to the intrabuilding network cable (INC) (riser cable). INC is the distribution facility inside a subscriber's building or between buildings on one customer's same premises (continuous property not separated by a public street or road). USL-INC (riser cable) will include the facility from the cross-connect device in the building equipment room up to and including the point of demarcation.

2.6.4. Requirements for Unbundled Sub-Loop Distribution Facilities

2.6.4.1 Unbundled Sub-Loop distribution facilities were originally built as part of the entire voice grade loop from the BellSouth central office to the customer network interface. Therefore, the Unbundled Sub-Loop distribution facilities may have load coils, which are necessary for transmission of voice grade services. The Unbundled Sub-Loops will be provided in accordance with technical reference TR73600.

2.6.4.2 Unbundled Sub-Loop distribution facilities shall support functions associated with provisioning, maintenance and testing of the Unbundled Sub-Loop. In a scenario that involves connection at a BellSouth cross-box located in the field, Level 3 would be required to deliver a cable to the BellSouth remote terminal or cross-box to provide continuity to Level 3's feeder facilities. This cable would be connected, by a BellSouth technician, to a cross-connect panel within the BellSouth RT/cross-box. Level 3's cable pairs can then be connected to BellSouth's USL within the BellSouth cross-box by the BellSouth technician. In a scenario that requires connection in a building equipment room, BellSouth will install a cross connect panel on which access to the requested sub-loops will be connected. The CLEC's cable pairs can then be connected to the Unbundled Sub-Loop pairs on this cross-connect panel by the BellSouth technician.

2.6.4.3 BellSouth will provide Unbundled Sub-Loops where available and technically feasible. Through the firm order Service Inquiry (SI) process, BellSouth will determine if it is

- technically feasible to place the required facilities where Level 3 has requested access to Unbundled Sub-Loops. If existing capacity is sufficient to meet the CLEC demand (as capacity shall be determined on a nondiscriminatory, first-come, first-served basis), then BellSouth will perform the set-up work as described in the next section 2.6.4.4 . If any work must be done to modify existing BellSouth facilities or add new facilities (other than adding the cross-connect panel in a building equipment room as noted in 2.6.4.4) to accommodate Level 3's request for Unbundled Sub-Loops, BellSouth will use its Special Construction (SC) process to determine the additional costs required to provision the Unbundled Sub-Loops. Level 3 will then have the option of paying the one-time SC charge to modify the facilities to meet Level 3's request.
- 2.6.4.4 During the initial set-up in a BellSouth cross-connect box in the field, the BellSouth technician will perform the necessary work to splice the CLEC's cable into the cross-connect box. For the set-up inside a building equipment room, BellSouth will perform the necessary work to install the cross-connect panel that will be used to provide access to the requested USLs. Once the set-up is complete, the CLEC requested sub-loop pairs would be provisioned through the service order process based on the submission of a LSR to the LCSC.
- 2.6.5 Interface Requirements
- 2.6.5.1 Unbundled Sub-Loop shall be equal to or better than each of the applicable requirements set forth in the applicable industry standard technical references.
- 2.6.6 **Unbundled Sub-Loop Concentration System (USLC)**
- 2.6.6.1 Where facilities permit (as determined on a nondiscriminatory basis) and where necessary to comply with an effective Commission order, BellSouth will provide Level 3 with the ability to concentrate its sub-loops onto multiple DS1s back to the BellSouth Central Office. The DS1s will then be terminated into Level 3's collocation space. TR-008 and TR303 interface standards are available.
- 2.6.6.2 USLC, using the Lucent Series 5 equipment, will be offered in two different systems. System A will allow up to 96 of Level 3's sub-loops to be concentrated onto multiple DS1s. System B will allow an additional 96 of Level 3's sub-loops to be concentrated onto multiple DS1s. One System A may be supplemented with one System B and they both must be physically located in a single Series 5 dual channel bank. A minimum of two DS1s is required for each system (i.e., System A requires two DS1s and System B would require an additional two DS1s or four in total). The DS1 level facility that connects the remote terminal (RT) site with the serving wire center is known as a Feeder Interface. All DS1 Feeder Interfaces will terminate to the CLEC's collocation space within the SWC that serves the RT where the CLEC's sub-loops are connected. USLC service is offered with or without concentration and with or without a protection DS1.

2.6.6.3 In these scenarios Level 3 would be required to place a cross-box, RT, or other similar device and deliver a cable to the BellSouth remote terminal. This cable would be connected, by a BellSouth technician, to a cross-connect panel within the BellSouth RT/cross-box and would allow Level 3's sub-loops to then be placed on the ULSC and transported to its collocation space at a DS1 level.

2.6.7 Unbundled Network Terminating Wire (UNTW)

2.6.7.1 BellSouth agrees to offer its Unbundled Network Terminating Wire (UNTW) to Level 3 on a nondiscriminatory basis and pursuant to the following terms and conditions at rates as set forth in this Attachment.

2.6.7.2 Definition

2.6.7.2.1 Subject to applicable and effective FCC rules and orders, UNTW is a dedicated transmission facility that BellSouth provides from the Wiring Closet /Garden Terminal (or other type of cross-connect point) at the point of termination of BellSouth's loop distribution facilities to the end user's point of demarcation.

2.6.7.3 Requirements

2.6.7.3.1 BellSouth will offer spare pairs that are available to an end user's premises to Level 3. Available spare pairs are defined as pairs that are not being utilized by BellSouth or by a third party to provide an end user with working service at the time of Level 3's request for UNTW. If no spare pairs are available and the end user is no longer using BellSouth's local service, BellSouth will relinquish the first pair to Level 3. If after BellSouth has relinquished the first pair to Level 3 and the end user decides to change local service providers to BellSouth, Level 3 will relinquish the first pair back to BellSouth.

2.6.7.3.2 Notwithstanding the foregoing, should BellSouth subsequently require the use of additional pair(s) to provide for the activation of additional lines in an end users premises in response to a request from such end user, Level 3 agrees to surrender their spare pair(s) upon request by BellSouth.

2.6.7.3.3 If an end user of Level 3 desires to receive local exchange service from a service provider who is not a Party to this Agreement, and such third party service provider needs access to the BellSouth UNTW to provide local exchange service to the end user, then Level 3 agrees to surrender the requisite number of its inactive spare pair(s) if no other spare pair is available and upon request by BellSouth.

2.6.7.3.4 If Level 3 has placed NTW at a location and an end user desires to receive local exchange service from BellSouth and BellSouth needs access to Level 3's NTW to provide local exchange service to the end user, then Level 3 agrees to surrender the

requisite number of its spare pair(s) upon request by BellSouth under rates, terms, and conditions to be separately negotiated between the Parties.

2.6.7.3.5 In new construction, where possible, both Parties may at their option and with the property owner's agreement install their own NTW. In existing construction, BellSouth shall not be required to install new or additional NTW beyond existing NTW to provision the services to the CLEC.

2.6.8 Technical Requirements

2.6.8.1 In these scenarios, BellSouth will connect the requested UNTW pairs to a single point of interconnection (SPOI) designed for CLEC access to BellSouth's NTW. The SPOI will be installed either near BellSouth's garden terminal or wiring closet. Level 3 will be required to place a cross-box, terminal or other similar device and deliver a cable to this SPOI. Level 3 will then connect their cable to the cross-connect panel to access the requested UNTW pairs.

2.7 **Dark Fiber**

2.7.1 Definition

Dark Fiber is an optical transmission facility without attached multiplexing, aggregation or other electronics that connects two points within BellSouth's network. Dark Fiber is unused strands of optical fiber. It may be strands of optical fiber existing in aerial or underground structure. No line terminating elements terminated to such strands to operationalize its transmission capabilities will be available. No regeneration or optical amplification will be included with this element.

2.7.2 Requirements

2.7.2.1 BellSouth shall make available Dark Fiber on a nondiscriminatory basis where it exists in BellSouth's network and where, as a result of future building or deployment, it becomes available. If BellSouth has pre-existing plans to make specific use of the fiber within a two-year planning period, there is no requirement to provide said fiber to Level 3, provided that upon Level 3's request, BellSouth shall provide written certification to Level 3 that BellSouth has plans to use such fiber and shall describe generally its plans to make such use, subject to Level 3's representative signing a separate confidentiality agreement with respect to the disclosure of such plans.

2.7.2.2 If the requested dark fiber has any lightwave repeater equipment interspliced to it, BellSouth will remove such equipment at Level 3's request subject to time and materials charges.

2.7.2.3 Level 3 may test the quality of the Dark Fiber to confirm its usability and performance specifications.

- 2.7.2.4 BellSouth shall use its best efforts to provide to Level 3 information regarding the location, availability and performance of Dark Fiber within ten (10) business days for a records based answer and twenty (20) business days for a field based answer, after receiving a request from Level 3 ("Request"). Within such time period, BellSouth shall send written confirmation of availability of the Dark Fiber ("Confirmation"). From the time of the Request to forty-five (45) days after Confirmation, BellSouth shall hold such requested Dark Fiber for Level 3's use and may not allow any other party to use such media, including BellSouth.
- 2.7.2.5 BellSouth shall use its best efforts to make Dark Fiber available to Level 3 within thirty (30) business days after it receives written confirmation from Level 3 that the Dark Fiber previously deemed available by BellSouth is wanted for use by Level 3. This includes identification of appropriate connection points (e.g., Light Guide Interconnection (LGX) or splice points) to enable Level 3 to connect or splice Level 3 provided transmission media (e.g., optical fiber) or equipment to the Dark Fiber.
- 2.7.2.6 Dark Fiber shall meet the manufacturer's design specifications.
- 2.7.2.7 Level 3 may splice and test Dark Fiber obtained from BellSouth using Level 3 or Level 3 designated personnel. BellSouth shall provide appropriate interfaces to allow splicing and testing of Dark Fiber. BellSouth shall provide an excess cable length of 25 feet minimum (for fiber in underground conduit) to allow the uncoiled fiber to reach from the manhole to a splicing van.

2.8 Rates

The prices that Level 3 shall pay to BellSouth for Network Elements and Other Services are set forth in Exhibit C to this Attachment.

2.9 Operational Support Systems (OSS)

BellSouth has developed and made available the following mechanized systems by which Level 3 may submit LSRs electronically.

LENS	Local Exchange Navigation System
EDI	Electronic Data Interchange
TAG	Telecommunications Access Gateway

- 2.9.1 LSRs submitted by means of one of these interactive interfaces will incur an OSS electronic ordering charge as specified in the table below. An individual LSR will be identified for billing purposes by its Purchase Order Number (PON). LSRs submitted by means other than one of these interactive interfaces (mail, fax, courier, etc.) will incur a manual order charge as specified in the table below:

OPERATIONAL SUPPORT SYSTEMS	AL, GA, LA,	FL, KY, TN
------------------------------------	--------------------	-------------------

	MS, NC, SC	
OSS LSR charge, per LSR received from the CLEC by one of the OSS interactive interfaces	\$3.50	\$3.50
	SOMEK	SOMEK
Incremental charge per LSR received from the CLEC by means other than one of the OSS interactive interfaces	See applicable rate element	\$19.99
		SOMAN

2.9.2 Denial/Restoral OSS Charge

In the event Level 3 provides a list of customers to be denied and restored, rather than an LSR, each location on the list will require a separate PON and, therefore will be billed as one LSR per location.

2.9.3 Cancellation OSS Charge

Level 3 will incur an OSS charge for an accepted LSR that is later canceled by Level 3.

Note: Supplements or clarifications to a previously billed LSR will not incur another OSS charge.

2.9.4 Network Elements and Other Services Manual Additive

2.9.4.1 The Commissions in some states have ordered per-element manual additive non-recurring charges (NRC) for Network Elements and Other Services ordered by means other than one of the interactive interfaces. These ordered Network Elements and Other Services manual additive NRCs will apply in these states, rather than the charge per LSR. The per-element charges are listed on the Rate Tables in Exhibit C.

3. **Switching**

All of the negotiated rates, terms and conditions set forth in this Section pertain to the provision of local and tandem switching.

3.1 **Local Switching**

BellSouth shall provide non-discriminatory access to local circuit switching capability, and local tandem switching capability, on an unbundled basis, except as set forth below in Section 3.1.3 to Level 3 for the provision of a telecommunications service.

BellSouth shall provide non-discriminatory access to packet switching capability on an unbundled basis to Level 3 for the provision of a telecommunications service only in the limited circumstance described below in Section 3.3.4.6.

- 3.1.1. Except as otherwise provided herein, BellSouth shall not impose any restrictions on Level 3 regarding the use of Switching Capabilities purchased from BellSouth provided such use does not result in demonstrable harm to either the BellSouth network or personnel or the use of the BellSouth network by BellSouth or any other telecommunication carrier.
- 3.1.2. Local Circuit Switching Capability, including Tandem Switching Capability
- 3.1.2.1 Definition
- Local Circuit Switching Capability is defined as: (A) line-side facilities, which include, but are not limited to, the connection between a loop termination at a main distribution frame and a switch line card; (B) trunk-side facilities, which include, but are not limited to, the connection between trunk termination at a trunk-side cross-connect panel and a switch trunk card; and (C) All features, functions, and capabilities of the switch, which include, but are not limited to: (1) the basic switching function of connecting lines to lines, line to trunks, trunks to lines, and trunks to trunks, as well as the same basic capabilities made available to BellSouth's customers, such as a telephone number, white page listings, and dial tone; and (2) all other features that the switch is capable of providing, including but not limited to customer calling, customer local area signaling service features, and Centrex, as well as any technically feasible customized routing functions provided by the switch; (D) switching provided by remote switching modules.
- 3.1.2.2 When utilizing BellSouth's local circuit switching capability, local traffic shall be defined as set forth in Part B of the General Terms and Conditions.
- 3.1.3 Notwithstanding BellSouth's general duty to unbundle local circuit switching, BellSouth shall not be required to unbundle local circuit switching for Level 3 when Level 3 serves end-users with four (4) or more voice-grade (DS-0) equivalents or lines in locations served by BellSouth's local circuit switches, which are in the following MSAs: Atlanta, GA; Miami, FL; Orlando, FL; Ft. Lauderdale, FL; Charlotte-Gastonia-Rock Hill, NC; Greensboro-Winston Salem-High Point, NC; Nashville, TN; and New Orleans, LA, and BellSouth has provided non-discriminatory cost based access to the Enhanced Extended Link (EEL) throughout Density Zone 1 as determined by NECA Tariff No. 4 as in effect on January 1, 1999.
- 3.1.4 In the event that Level 3 orders local circuit switching for a single end user account name at a single physical end user location with four (4) or more two (2) wire voice-grade loops from a BellSouth central office located in those MSAs listed in Section 3.1.3 above, BellSouth's sole recourse shall be to charge Level 3 a rate to be negotiated for use of the local circuit switching functionality for the affected facilities, or in the alternative, to charge Level 3 the local services resale rate for use of all Combinations used to provide the affected facilities to Level 3.

- 3.1.5 A featureless port is one that has a line port, switching facilities, and an interoffice port. A featured port is a port that includes all features then capable or a number of then capable features specifically requested by Level 3. Any features that are not currently then capable but are technically feasible through the switch can be requested through the BFR process.
- 3.1.6 BellSouth will provide to Level 3 customized routing of calls: (i) to a requested directory assistance services platform; (ii) to an operator services platform pursuant to Section 10 of Attachment 2; or (iii) for Level 3's PIC'ed toll traffic in a two (2) PIC environment to an alternative OS/DA platform designated by Level 3. Level 3 customers may use the same dialing arrangements as BellSouth customers.
- 3.1.7 Remote Switching Module functionality is included in Switching Capability. The switching capabilities used will be based on the line side features they support.
- 3.1.8 Switching Capability will also be capable of routing local, intraLATA, interLATA, and calls to international customer's preferred carrier; call features (e.g. call forwarding) and Centrex capabilities.
- 3.1.9 Where required to do so in order to comply with an effective Commission order, BellSouth will provide to Level 3 purchasing local BellSouth switching or reselling BellSouth local exchange service under Attachment 1, selective routing of calls to a requested directory assistance services platform or operator services platform. Level 3 customers may use the same dialing arrangements as BellSouth customers, but obtain a Level 3 branded service.
- 3.2 Technical Requirements
- 3.2.1 The requirements set forth in this Section apply to Local Switching, but not to the Data Switching function of Local Switching.
- 3.2.1.1 Local Switching shall be equal to or better than the requirements for Local Switching set forth in the applicable industry standard technical references.
- 3.2.1.2 When applicable, BellSouth shall route calls to the appropriate trunk or lines for call origination or termination.
- 3.2.1.3 Subject to this section, BellSouth shall route calls on a per line or per screening class basis to (1) BellSouth platforms providing Network Elements or additional requirements (2) Operator Services platforms, (3) Directory Assistance platforms, and (4) Repair Centers. Any other routing requests by Level 3 will be made pursuant to the Bona Fide Request/ New Business Request Process as set forth in General Terms and Conditions.

- 3.2.1.4 BellSouth shall provide unbranded recorded announcements and call progress tones to alert callers of call progress and disposition.
- 3.2.1.5 BellSouth shall activate service for a Level 3 customer or network interconnection on any of the Local Switching interfaces. This includes provisioning changes to change a customer from BellSouth's services to Level 3's services without loss of switch feature functionality as defined in this Agreement.
- 3.2.1.6 BellSouth shall perform routine testing (e.g., Mechanized Loop Tests (MLT) and test calls such as 105, 107 and 108 type calls) and fault isolation on a mutually agreed upon schedule.
- 3.2.1.7 BellSouth shall repair and restore any equipment or any other maintainable component that may adversely impact Local Switching.
- 3.2.1.8 BellSouth shall control congestion points such as those caused by radio station call-ins, and network routing abnormalities. All traffic shall be restricted in a non-discriminatory manner.
- 3.2.1.9 BellSouth shall perform manual call trace and permit customer originated call trace.
- 3.2.1.10 Special Services provided by BellSouth will include the following:
 - 3.2.1.10.1 Telephone Service Prioritization;
 - 3.2.1.10.2 Related services for handicapped;
 - 3.2.1.10.3 Soft dial tone where required by law; and
 - 3.2.1.10.4 Any other service required by law.
- 3.2.1.11 BellSouth shall provide Switching Service Point (SSP) capabilities and signaling software to interconnect the signaling links destined to the Signaling Transfer Point Switch (STPS). These capabilities shall adhere to the technical specifications set forth in the applicable industry standard technical references.
- 3.2.1.12 BellSouth shall provide interfaces to adjuncts through Telcordia (formerly BellCore) standard interfaces. These adjuncts can include, but are not limited to, the Service Circuit Node and Automatic Call Distributors.
- 3.2.1.13 BellSouth shall provide performance data regarding a customer line, traffic characteristics or other measurable elements to Level 3, upon a reasonable request from Level 3. CLEC will pay BellSouth for all costs incurred to provide such performance data through the Bona Fide Request process.

- 3.2.1.14 BellSouth shall offer Local Switching that provides feature offerings at parity to those provided by BellSouth to itself or any other Party. Such feature offerings shall include but are not limited to:
 - 3.2.1.14.1 Basic and primary rate ISDN;
 - 3.2.1.14.2 Residential features;
 - 3.2.1.14.3 Customer Local Area Signaling Services (CLASS/LASS);
 - 3.2.1.14.4 CENTREX (including equivalent administrative capabilities, such as customer accessible reconfiguration and detailed message recording); and
 - 3.2.1.14.5 Advanced intelligent network triggers supporting Level 3 and BellSouth service applications.
- 3.2.2 BellSouth shall offer to Level 3 all available AIN triggers in connection with its SMS/SCE offering which are supported by BellSouth for offering AIN-based services. These currently include, but may not be limited to:
 - 3.2.2.1 Off-Hook Immediate
 - 3.2.2.2 Off-Hook Delay
 - 3.2.2.3 Termination Attempt
 - 3.2.2.4 6/10 Public Office Dialing Plan
 - 3.2.2.5 Feature Code Dialing
 - 3.2.2.6 Customer Dialing Plan
- 3.2.3 When the following triggers are supported by BellSouth, BellSouth will make these triggers available to Level 3:
 - 3.2.3.1 Private EAMF Trunk
 - 3.2.3.2 Shared Interoffice Trunk (EAMF, SS7)
 - 3.2.3.3 N11
 - 3.2.3.4 Automatic Route Selection
- 3.2.4 Where capacity exists, BellSouth shall assign each Level 3 customer line the class of service designated by Level 3 (e.g., using line class codes or other switch specific provisioning methods), and shall route directory assistance calls from Level 3 customers to Level 3 directory assistance operators at Level 3's option.

- 3.2.5 Where capacity exists, BellSouth shall assign each Level 3 customer line the class of services designated by Level 3 (e.g., using line class codes or other switch specific provisioning methods) and shall route operator calls from Level 3 customers to Level 3 operators at Level 3's option. For example, BellSouth may translate 0- and 0+ intraLATA traffic, and route the call through appropriate trunks to an Level 3 Operator Services Position System (OSPS). Calls from Local Switching must pass the ANI-II digits unchanged.
- 3.2.6 Local Switching shall be offered in accordance with the technical specifications set forth in the applicable industry standard references.
- 3.2.7 Interface Requirements
- 3.2.7.1 BellSouth shall provide all technically feasible and available interfaces to loops, including the following interfaces to loops:
- 3.2.7.1.1 Standard Tip/Ring interface including loopstart or groundstart, on-hook signaling (e.g., for calling number, calling name and message waiting lamp);
- 3.2.7.1.2 Coin phone signaling;
- 3.2.7.1.3 Basic Rate Interface ISDN adhering to appropriate Telcordia (formerly BellCore) Technical Requirements;
- 3.2.7.1.4 Two-wire analog interface to PBX;
- 3.2.7.1.5 Four-wire analog interface to PBX;
- 3.2.7.1.6 Four-wire DS1 interface to PBX or customer provided equipment (e.g. computers and voice response systems);
- 3.2.7.1.7 Primary Rate ISDN to PBX adhering to ANSI standards Q.931, Q.932 and appropriate Telcordia (formerly BellCore) Technical Requirements;
- 3.2.7.1.8 Switched Fractional DS1 with capabilities to configure Nx64 channels (where N = 1 to 24); and
- 3.2.7.1.9 Loops adhering to Telcordia (formerly BellCore) TR-NWT-08 and TR-NWT-303 specifications to interconnect Digital Loop Carriers.
- 3.2.7.2 BellSouth shall provide access to the following but not limited to:
- 3.2.7.2.1 SS7 Signaling Network or Multi-Frequency trunking if requested by Level 3;

- 3.2.7.2.2 Interface to Level 3 operator services systems or Operator Services through appropriate trunk interconnections for the system; and
- 3.2.7.2.3 Interface to Level 3 Directory Assistance Services through the Level 3 switched network or to Directory Assistance Services through the appropriate trunk interconnections for the system; and 950 access or other Level 3 required access to interexchange carriers as requested through appropriate trunk interfaces.

3.3 Tandem Switching

3.3.1 Definition

Tandem Switching is the function that establishes a communications path between two switching offices through a third switching office (the Tandem switch).

3.3.2 Technical Requirements

3.3.2.1 Tandem Switching shall have the same capabilities or equivalent capabilities as those described in Bell Communications Research TR-TSY-000540 Issue 2R2, Tandem Supplement, 6/1/90. The requirements for Tandem Switching include, but are not limited to the following:

- 3.3.2.1.1 Tandem Switching shall provide signaling to establish a tandem connection;
- 3.3.2.1.2 Tandem Switching will provide screening as jointly agreed to by Level 3 and BellSouth;
- 3.3.2.1.3 Tandem Switching shall provide Advanced Intelligent Network triggers supporting AIN features where such routing is not available from the originating end office switch, to the extent such Tandem switch has such capability;
- 3.3.2.1.4 Tandem Switching shall provide access to Toll Free number portability database as designated by Level 3;
- 3.3.2.1.5 Tandem Switching shall provide all trunk interconnections discussed under the “Network Interconnection” section (e.g., SS7, MF, DTMF, DialPulse, PRI-ISDN, DID, and CAMA-ANI (if appropriate for 911));
 - 3.3.2.1.5.1 Tandem Switching shall provide connectivity to PSAPs where 911 solutions are deployed and the tandem is used for 911; and
 - 3.3.2.1.5.2 Where appropriate, Tandem Switching shall provide connectivity to transit traffic to and from other carriers.

- 3.3.2.1.6 Tandem Switching shall accept connections (including the necessary signaling and trunking interconnections) between end offices, other tandems, IXCs, ICOs, CAPs and CLEC switches.
- 3.3.2.1.7 Tandem Switching shall provide local tandeming functionality between two end offices including two offices belonging to different CLEC's (e.g., between a CLEC end office and the end office of another CLEC).
- 3.3.2.1.8 Tandem Switching shall preserve CLASS/LASS features and Caller ID as traffic is processed.
- 3.3.2.1.9 Tandem Switching shall record billable events and send them to the area billing centers designated by Level 3. Tandem Switching will provide recording of all billable events as jointly agreed to by Level 3 and BellSouth.
- 3.3.2.1.10 Upon a reasonable request from Level 3, BellSouth shall perform routine testing and fault isolation on the underlying switch that is providing Tandem Switching and all its interconnections. The results and reports of the testing shall be made immediately available to Level 3.
- 3.3.2.1.11 BellSouth shall maintain Level 3's trunks and interconnections associated with Tandem Switching at least at parity to its own trunks and interconnections.
- 3.3.2.1.12 BellSouth shall control congestion points and network abnormalities. All traffic will be restricted in a non-discriminatory manner.
- 3.3.2.1.13 Selective Call Routing through the use of line class codes is not available through the use of tandem switching. Selective Call Routing through the use of line class codes is an end office capability only. Detailed primary and overflow routing plans for all interfaces available within BellSouth's switching network shall be mutually agreed to by Level 3 and BellSouth.
- 3.3.2.1.14 Tandem Switching shall process originating toll-free traffic received from Level 3's local switch.
- 3.3.2.1.15 In support of AIN triggers and features, Tandem Switching shall provide SSP capabilities when these capabilities are not available from the Local Switching Network Element, to the extent such Tandem Switch has such capability.
- 3.3.2.2 Interface Requirements
 - 3.3.2.2.1 Tandem Switching shall provide interconnection to the E911 PSAP where the underlying Tandem is acting as the E911 Tandem.

- 3.3.2.2.2 Tandem Switching shall interconnect, with direct trunks, to all carriers with which BellSouth interconnects.
 - 3.3.2.2.3 BellSouth shall provide all signaling necessary to provide Tandem Switching with no loss of feature functionality.
 - 3.3.2.2.4 Tandem Switching shall interconnect with Level 3's switch, using two-way trunks, for traffic that is transiting via BellSouth's network to interLATA or intraLATA carriers. At Level 3's request, Tandem Switching shall record and keep records of traffic for billing.
 - 3.3.2.2.5 Tandem Switching shall provide an alternate final routing pattern for Level 3's traffic overflowing from direct end office high usage trunk groups.
 - 3.3.2.2.6 Tandem Switching shall be equal or better than the requirements for Tandem Switching set forth in the applicable technical references.
- 3.4 **AIN Selective Carrier Routing for Operator Services, Directory Assistance and Repair Centers**
- 3.4.1 BellSouth will provide AIN Selective Carrier Routing at the request of Level 3. AIN Selective Carrier Routing will provide Level 3 with the capability of routing operator calls, 0+ and 0- and 0+ NPA (LNPA) 555-1212 directory assistance, 1+411 directory assistance and 611 repair center calls to pre-selected destinations.
 - 3.4.2 Level 3 shall order AIN Selective Carrier Routing through its Account Team. AIN Selective Carrier Routing must first be established regionally and then on a per central office, per state basis.
 - 3.4.3 AIN Selective Carrier Routing is not available in DMS 10 switches.
 - 3.4.4 Where AIN Selective Carrier Routing is utilized by Level 3, the routing of Level 3's end user calls shall be pursuant to information provided by Level 3 and stored in BellSouth's AIN Selective Carrier Routing Service Control Point database. AIN Selective Carrier Routing shall utilize a set of Line Class Codes (LCCs) unique to a basic class of service assigned on an 'as needed basis. The same LCCs will be assigned in each central office where AIN Selective Carrier Routing is established.
 - 3.4.5 Upon ordering of AIN Selective Carrier Routing Regional Service, Level 3 shall remit to BellSouth the Regional Service Order non-recurring charges set forth in Exhibit A of this Attachment. There shall be a non-recurring End Office Establishment Charge per office due at the addition of each central office where AIN Selective Carrier

- Routing will be utilized. Said non-recurring charge shall be as set forth in Exhibit A of this Attachment. For each Level 3 end user activated, there shall be a non-recurring End User Establishment charge as set forth in Exhibit A of this Attachment, payable to BellSouth pursuant to the terms of the General Terms and Conditions, incorporated herein by this reference. Level 3 shall pay the AIN Selective Carrier Routing Per Query Charge set forth in Exhibit A of this Attachment.
- 3.4.6 This Regional Service Order non-recurring charge will be non-refundable and will be paid with 1/2 coming up-front with the submission of all fully completed required forms, including: Regional Selective Carrier Routing (SCR) Order Request-Form A, Central Office AIN Selective Carrier Routing (SCR) Order Request - Form B, AIN_SCR Central Office Identification Form - Form C, AIN_SCR Routing Options Selection Form - Form D, and Routing Combinations Table - Form E. BellSouth has 30 days to respond to the client's fully completed firm order as a Regional Service Order. With the delivery of this firm order response to the client, BellSouth considers that the delivery schedule of this service commences. The remaining 1/2 of the Regional Service Order payment must be paid when one hundred percent (100%) of the Central Offices listed on the original order have been turned up for the service.
- 3.4.7 The non-recurring End Office Establishment Charge will be billed to the client following BellSouth's normal monthly billing cycle for this type of order.
- 3.4.8 End-User Establishment Orders will not be turned-up until the 2nd payment is received for the Regional Service Order. The non-recurring End-User Establishment Charges will be billed to the client following BellSouth's normal monthly billing cycle for this type of order.
- 3.4.9 Additionally, the AIN Selective Carrier Routing Per Query Charge will be billed to the client following the normal billing cycle for per query charges.
- 3.4.10 All other network components needed, for example, unbundled switching and unbundled local transport, etc, will be billed according per contracted rates.

3.5 Packet Switching Capability

3.5.1 Definition

Packet Switching Capability. The packet switching capability network element is defined as the basic packet switching function of routing or forwarding packets, frames, cells or other data units based on address or other routing information contained in the packets, frames, cells or other data units, and the functions that are performed by Digital Subscriber Line Access Multiplexers, including but not limited to:

- 3.5.2 The ability to terminate copper customer loops (which includes both a low band voice channel and a high-band data channel, or solely a data channel);
- 3.5.3 The ability to forward the voice channels, if present, to a circuit switch or multiple circuit switches;
- 3.5.4 The ability to extract data units from the data channels on the loops, and
- 3.5.5 The ability to combine data units from multiple loops onto one or more trunks connecting to a packet switch or packet switches.
- 3.5.6 BellSouth shall be required to provide non-discriminatory access to unbundled packet switching capability only where each of the following conditions are satisfied:
 - 3.5.6.1 BellSouth has deployed digital loop carrier systems, including but not limited to, integrated digital loop carrier or universal digital loop carrier systems; or has deployed any other system in which fiber optic facilities replace copper facilities in the distribution section (e.g., end office to remote terminal, pedestal or environmentally controlled vault);
 - 3.5.6.2 There are no spare copper loops capable of supporting the xDSL services Level 3 seeks to offer;
 - 3.5.6.3 BellSouth has not permitted any requesting carrier to deploy a Digital Subscriber Line Access Multiplexer at the remote terminal, pedestal or environmentally controlled vault or other interconnection point, nor has Level 3 obtained a virtual collocation arrangement at these subloop interconnection points as defined by 47 C.F.R. § 51.319 (b); and
 - 3.5.6.4 BellSouth has deployed packet switching capability for its own use.
- 3.5.7 If there is a dispute as to whether BellSouth must provide Packet Switching, such dispute will be resolved according to the dispute resolution process set forth in Section 12 of the General Terms and Conditions of this Agreement, incorporated herein by this reference.

3.6 **Rates**

The prices that Level 3 shall pay to BellSouth for Network Elements and Other Services are set forth in Exhibit C to this Attachment.

3.7 **Operational Support Systems (OSS)**

BellSouth has developed and made available the following mechanized systems by which Level 3 may submit LSRs electronically.

LENS	Local Exchange Navigation System
EDI	Electronic Data Interchange
TAG	Telecommunications Access Gateway

- 3.7.1 LSRs submitted by means of one of these interactive interfaces will incur an OSS electronic ordering charge as specified in the table below. An individual LSR will be identified for billing purposes by its Purchase Order Number (PON). LSRs submitted by means other than one of these interactive interfaces (mail, fax, courier, etc.) will incur a manual order charge as specified in the table below:

OPERATIONAL SUPPORT SYSTEMS	AL, GA, LA, NC, MS, SC	FL, KY, TN
OSS LSR charge, per LSR received from the CLEC by one of the OSS interactive interfaces	\$3.50	\$3.50
	SOMECH	SOMECH
Incremental charge per LSR received from the CLEC by means other than one of the OSS interactive interfaces	See applicable rate element	\$19.99
		SOMAN

3.7.2 Denial/Restoral OSS Charge

In the event Level 3 provides a list of customers to be denied and restored, rather than an LSR, each location on the list will require a separate PON and, therefore will be billed as one LSR per location.

3.7.3 Cancellation OSS Charge

Level 3 will incur an OSS charge for an accepted LSR that is later canceled by Level 3.

Note: Supplements or clarifications to a previously billed LSR will not incur another OSS charge.

3.7.4 Network Elements and Other Services Manual Additive

- 3.7.4.1 The Commissions in some states have ordered per-element manual additive non-recurring charges (NRC) for Network Elements and Other Services ordered by means other than one of the interactive interfaces. These ordered Network Elements and Other Services manual additive NRCs will apply in these states, rather than the charge per LSR. The per-element charges are listed on the Rate Tables in Exhibit A.

4. **Combinations**

- 4.1 For purposes of this Section, references to “Currently Combined” network elements shall mean that such network elements are in fact already combined by BellSouth in the BellSouth network.
- 4.2 **EELs.**
- 4.2.1 Where facilities permit and where necessary to comply with an effective FCC and/or State Commission order, or as otherwise mutually agreed by the Parties, BellSouth shall offer access to loop and transport combinations, also known as the Enhanced Extended Link (“EEL”) as defined in Section 4.3 below.
- 4.2.2 Subject to Section 4.2.3 below, BellSouth will provide access to the EEL in the combinations set forth in 4.3 following. This offering is intended to provide connectivity from an end user’s location through that end user’s SWC to Level 3’s POP serving wire center. The circuit must be connected to Level 3’s switch for the purpose of provisioning telephone exchange service to Level 3’s end-user customers. The EEL will be connected to Level 3’s facilities in Level 3’s collocation space at the POP SWC, or Level 3 may purchase BellSouth’s dedicated transport or access facilities (as such are specifically ordered and utilized by Level 3) between Level 3’s POP and Level 3’s collocation space at the POP SWC.
- 4.2.3 BellSouth shall provide EEL combinations to Level 3 in the state of Georgia regardless of whether or not such EELs are Currently Combined. In all other states, BellSouth shall make available to Level 3 those EEL combinations described in Section 4.3 below only to the extent such combinations are Currently Combined. Furthermore, BellSouth will make available EEL combinations to Level 3 in density Zone 1, as defined in 47 C.F.R. 69.123 as of January 1, 1999, in the Miami, Orlando, Fort Lauderdale, Charlotte, New Orleans, Greensboro and Nashville MSAs, regardless of whether or not such EELs are Currently Combined. Except as stated above, EELs will be provided to Level 3 only to the extent such network elements are Currently Combined.
- 4.2.4 Additionally, BellSouth shall make available to Level 3 a combination of an unbundled loop and tariffed special access interoffice facilities. To the extent Level 3 will require multiplexing functionality in connection with such combination, BellSouth will provide access to multiplexing within the central office pursuant to the terms, conditions and rates set forth in its Access Services Tariffs. The tariffed special access interoffice facilities and any associated tariffed services, including but not limited to multiplexing, shall not be eligible for conversion to UNEs as described in Section 4.5 below.
- 4.3 EEL Combinations

- 4.3.1 DS1 Interoffice Channel + DS1 Channelization + 2-wire VG Local Loop
- 4.3.2 DS1 Interoffice Channel + DS1 Channelization + 4-wire VG Local Loop
- 4.3.3 DS1 Interoffice Channel + DS1 Channelization + 2-wire ISDN Local Loop
- 4.3.4 DS1 Interoffice Channel + DS1 Channelization + 4-wire 56 kbps Local Loop
- 4.3.5 DS1 Interoffice Channel + DS1 Channelization + 4-wire 64 kbps Local Loop
- 4.3.6 DS1 Interoffice Channel + DS1 Local Loop
- 4.3.7 DS3 Interoffice Channel + DS3 Local Loop
- 4.3.8 STS-1 Interoffice Channel + STS-1 Local Loop
- 4.3.9 DS3 Interoffice Channel + DS3 Channelization + DS1 Local Loop
- 4.3.10 STS-1 Interoffice Channel + DS3 Channelization + DS1 Local Loop
- 4.3.11 2-wire VG Interoffice Channel + 2-wire VG Local Loop
- 4.3.12 4wire VG Interoffice Channel + 4-wire VG Local Loop
- 4.3.13 4-wire 56 kbps Interoffice Channel + 4-wire 56 kbps Local Loop
- 4.3.14 4-wire 64 kbps Interoffice Channel + 4-wire 64 kbps Local Loop

4.4 Other Network Element Combinations

In the state of Georgia, BellSouth shall make available to Level 3, in accordance with Section 4.6 below: (1) combinations of network elements other than EELs that are Currently Combined; and (2) combinations of network elements other than EELs that are not Currently Combined but that BellSouth ordinarily combines in its network. In all other states, BellSouth shall make available to Level 3, in accordance with Section 4.6 below, combinations of network elements other than EELs only to the extent such combinations are Currently Combined.

4.5 Special Access Service Conversions

- 4.5.1 Level 3 may not convert special access services to combinations of loop and transport network elements, whether or not Level 3 self-provides its entrance facilities (or

obtains entrance facilities from a third party), unless Level 3 uses the combination to provide a "significant amount of local exchange service" (as described in this Section), in addition to exchange access service, to a particular customer. For the purpose of special access conversions, a "significant amount of local exchange service" is as defined in the FCC's June 2, 2000 Order. The Parties agree to incorporate by reference paragraph 22 of the June 2, 2000 Order. When Level 3 requests conversion of special access circuits, Level 3 will self-certify to BellSouth in the manner specified in paragraph 29 of the June 2, 2000 Order that the circuits to be converted qualify for conversion and the local usage option upon which Level 3 is relying for such conversion. BellSouth may, at its sole expense, and upon thirty (30) days notice to Level 3, audit Level 3's records not more than one in any twelve month period, unless an audit finds non-compliance with the local usage options referenced in the June 2, 2000 Order, in order to verify the type of traffic being transmitted over combinations of loop and transport network elements. If, based on its audits, BellSouth concludes that Level 3 is not providing a significant amount of local exchange traffic over the combinations of loop and transport network elements, BellSouth may file a complaint with the appropriate Commission, pursuant to the dispute resolution process as set forth in this Agreement.

4.6 Rates

4.6.1 Georgia

4.6.1.1 The non-recurring and recurring rates for the EEL Combinations of network elements set forth in 4.3, whether Currently Combined or new, are as set forth in Exhibit A of this Amendment.

4.6.1.2 On an interim basis, for combinations of loop and transport network elements not set forth in Section 4.3, where the elements are not Currently Combined but are ordinarily combined in BellSouth's network, the non-recurring and recurring charges for such UNE combinations shall be the sum of the stand-alone non-recurring and recurring charges of the network elements which make up the combination. These interim rates shall be subject to true-up based on the Commission's review of BellSouth's cost studies.

4.6.1.3 To the extent that Level 3 seeks to obtain other combinations of network elements that BellSouth ordinarily combines in its network which have not been specifically priced by the Commission when purchased in combined form, Level 3, at its option, can request that such rates be determined pursuant to the Bona Fide Request/New Business Request (NBR) process set forth in this Agreement.

4.6.2 All Other States

4.6.2.1 Subject to Section 4.2.3 and 4.4 preceding, for all other states, the non-recurring and recurring rates for the Currently Combined EEL combinations set forth in Section 4.3 and other Currently Combined network elements will be the sum of the recurring rates

for the individual network elements plus a nonrecurring charge (the “Switch As Is” charge specified in Exhibit C) unless otherwise negotiated by the parties.

4.6.3 Multiplexing

Where multiplexing functionality is required in connection with loop and transport combinations, such multiplexing will be provided at the rates and on the terms set forth in this Agreement.

5. Port/Loop Combinations

5.1 At Level 3’s request, BellSouth shall provide access to combinations of port and loop network elements, as set forth in Section 5.4 below, that are currently combined in BellSouth’s network except as specified in Sections 5.1.1 and 5.1.2 below.

5.1.1 BellSouth is not required to provide access to combinations of port and loop network elements in locations where BellSouth is not required to provide circuit switching.

5.1.2 BellSouth is not required to provide circuit switching in density Zone 1, as defined in 47 C.F.R. 69.123 as of January 1, 1999, of the Atlanta, Miami, Orlando, Fort Lauderdale, Charlotte, New Orleans, Greensboro and Nashville MSAs to Level 3 if Level 3’s customer has 4 or more DS0 equivalent lines.

5.2 Definition

5.2.1 For purposes of this Section, references to Currently Combined network elements shall mean that such network elements are in fact already combined in the BellSouth network.

5.2.2 Combinations of port and loop network elements provide local exchange service for the origination or termination of calls. Section 5.4 following provides the combinations of port and loop network elements that may be ordered by Level 3 when currently combined except in those locations where BellSouth is not required to provide circuit switching, as set forth in Section 5.1.2 above.

5.2.3 In Georgia, BellSouth shall provide combinations of port and loop network elements to Level 3 regardless of whether or not such combinations are Currently Combined except in those locations where BellSouth is not required to provide circuit switching, as set forth in Section 5.1.2 above.

5.3 Rates for Combinations of Loop and Port Network Elements

5.3.1 Rates for combinations of loop and port network elements, as set forth in Section 5.4, are provided in Exhibit A of this Attachment

5.3.2 Rates for Circuit Switching

5.3.2.1 Rates for circuit switching, where BellSouth is not required, pursuant to Section 5.1, to provide circuit switching are as set forth in Exhibit A of this Attachment.

5.4 Combination Offerings

5.4.1 2-wire voice grade port, voice grade loop, virtual cross connect, unbundled end office switching, unbundled end office trunk port, common transport per mile per MOU, common transport facilities termination, tandem switching, and tandem trunk port.

5.4.2 2-wire voice grade DID port, voice grade loop, virtual cross connect, unbundled end office switching, unbundled end office trunk port, common transport per mile per MOU, common transport facilities termination, tandem switching, and tandem trunk port.

5.4.3 2-wire CENTREX port, voice grade loop virtual cross connect, unbundled end office switching, unbundled end office trunk port, common transport per mile per MOU, common transport facilities termination, tandem switching, and tandem trunk port.

5.4.4. 2-wire ISDN Basic Rate Interface, voice grade loop virtual cross connect, unbundled end office switching, unbundled end office trunk port, common transport per mile per MOU, common transport facilities termination, tandem switching, and tandem trunk port.

5.4.5 2-wire ISDN Primary Rate Interface, DS1 loop virtual cross connect, unbundled end office switching, unbundled end office trunk port, common transport per mile per MOU, common transport facilities termination, tandem switching, and tandem trunk port.

5.4.6 4-wire DS1 Trunk port, DS1 Loop virtual cross connect, unbundled end office switching, unbundled end office trunk port, common transport per mile per MOU, common transport facilities termination, tandem switching, and tandem trunk port.

6. **Transport and Dark Fiber**

BellSouth shall provide nondiscriminatory access, in accordance with 47 C.F.R. § 51.311 and Section 251(c)(3) of the Act, to interoffice transmission facilities on an unbundled basis to Level 3 for the provision of a telecommunications service. All of the negotiated rates, terms and conditions set forth in this Section pertain to the provision of unbundled transport and dark fiber.

6.1. **Transport**

6.1.1 Definition of Common (Shared) Transport

Common (Shared) Transport is an interoffice transmission path between two BellSouth end-offices, BellSouth end-office and a local tandem, or between two local tandems. Where BellSouth Network Elements are connected by intra-office wiring, such wiring is provided as a part of the Network Elements and is not Common (Shared) Transport. Common (Shared) Transport consists of BellSouth inter-office transport facilities and is unbundled from local switching.

6.1.2 Technical Requirements of Common (Shared) Transport

6.1.2.1 Common (Shared) Transport provided on DS1 or VT1.5 circuits, shall, at a minimum, meet the performance, availability, jitter, and delay requirements specified for Central Office to Central Office (“CO to CO”) connections in the appropriate industry standards.

6.1.2.2 Common (Shared) Transport provided on DS3 circuits, STS-1 circuits, and higher transmission bit rate circuits, shall, at a minimum, meet the performance, availability, jitter, and delay requirements specified for CO to CO connections in the appropriate industry standards.

6.1.2.3 BellSouth shall be responsible for the engineering, provisioning, and maintenance of the underlying equipment and facilities that are used to provide Common (Shared) Transport.

6.1.2.4 At a minimum, Common (Shared) Transport shall meet all of the requirements set forth in the applicable industry standard technical references.

6.2 Interoffice transmission facility network elements include:

6.2.1 Dedicated transport, defined as BellSouth’s transmission facilities, including all technically feasible capacity-related services including, but not limited to, DS1, DS3 and OCn levels, dedicated to a particular customer or carrier, that provide telecommunications between wire centers or switches owned by BellSouth, or between wire centers and switches owned by BellSouth and Level 3.

6.2.2 Dark Fiber transport, defined as BellSouth’s optical transmission facilities without attached multiplexing, aggregation or other electronics;

6.2.3 Shared transport, defined as transmission facilities shared by more than one carrier, including BellSouth, between end office switches, between end office switches and tandem switches, and between tandem switches, in BellSouth’s network.

6.2.4 BellSouth shall:

- 6.2.4.1 Provide Level 3 exclusive use of interoffice transmission facilities dedicated to a particular customer or carrier, or shared use of the features, functions, and capabilities of interoffice transmission facilities shared by more than one customer or carrier;
 - 6.2.4.2 Provide all technically feasible transmission facilities, features, functions, and capabilities that Level 3 could use to provide telecommunications services;
 - 6.2.4.3 Permit, to the extent technically feasible, Level 3 to connect such interoffice facilities to equipment designated by Level 3, including but not limited to, Level 3's collocated facilities; and
 - 6.2.4.4 Permit, to the extent technically feasible, Level 3 to obtain the functionality provided by BellSouth's digital cross-connect systems in the same manner that BellSouth provides such functionality to interexchange carriers.
- 6.2.5 Provided that the facility is used to transport a significant amount of local exchange services Level 3 shall be entitled to convert existing interoffice transmission facilities (i.e., special access) to the corresponding interoffice transport network element option.

6.3 Dedicated Transport

6.3.1 Definitions

6.3.2 Dedicated Transport is defined as BellSouth transmission facilities dedicated to a particular customer or carrier that provide telecommunications between wire centers owned by BellSouth or requesting telecommunications carriers, or between switches owned by BellSouth or requesting telecommunications carriers. BellSouth will offer Dedicated Transport with the same functionalities that it offers to interexchange carriers. All applicable Cross-Connect, multiplexing, and Collocation space charges shall apply at additional cost as specified in Exhibit C to this Attachment and the pricing schedule for Attachment 4. Examples of possible Dedicated Transport application locations include but are not limited to: (1) Dedicated Transport between a Level 3 POP and a Level 3 collocation arrangement at a BellSouth Serving Wire Center; and (2) Dedicated Transport between a Level 3 collocation arrangement at one BellSouth Premise and another Level 3 collocation arrangement at another BellSouth Premise.

6.3.3 Unbundled Local Channel

6.3.4 Unbundled Local Channel is the dedicated transmission path between Level 3's Point of Presence and Level 3's collocation arrangement at the BellSouth Serving Wire Center.

6.3.5 Unbundled Interoffice Channel.

- 6.3.6 Unbundled Interoffice Channel is the dedicated transmission path between Level 3's collocation arrangements at BellSouth's Serving Wire Centers.
- 6.3.7 BellSouth shall offer Dedicated Transport on a nondiscriminatory basis in each of the following ways:
- 6.3.7.1 As capacity on a shared UNE facility.
- 6.3.7.2 As a circuit (e.g., DS0, DS1, DS3, OCn) dedicated to Level 3. This circuit shall consist of an Unbundled Local Channel or an Unbundled Interoffice Channel or both. When Dedicated Transport is provided as a circuit or as capacity on a shared facility, it shall include multiplexing functionality, as appropriate (including, but not limited to, DS1/DS0 and DS3/DS1). The following dedicated transport arrangements with multiplexing capability will be made available pursuant to the BFR process: OC-3/DS3, OC-12/OC-3, OC-12/DS3, OC-48/OC-12, OC-48/OC-3, OC-48/DS3, OC-192/OC-12, and OC-192/OC-48, except to the extent previously made available to CLECs.
- 6.3.8 When Dedicated Transport is provided it shall include:
- 6.3.8.1 Transmission equipment such as, line terminating equipment, amplifiers, and regenerators;
- 6.3.8.2 Inter-office transmission facilities such as optical fiber, copper twisted pair, and coaxial cable.
- 6.3.9 BellSouth shall perform logical payload mapping of Dedicated Transport circuits in any technically feasible manner, including but not limited to: (1) Fully concatenated (e.g., the OC-12 is mapped at 1 x STS-12c); (2) Fully channelized (e.g., the OC-12 is mapped at 12 x STS-1); and (3) Any possible combination of concatenated and channelized (e.g., the circuit is mapped at 9 x STS-1 and 1 STS-3c).
- 6.3.10 The following optional features are available, if requested by Level 3, at the rates set forth in Exhibit C:
- 6.3.10.1 Clear Channel Capability per 1.544-Mbps ("DS1") bit stream;
- 6.3.10.2 BellSouth-provided Central Office multiplexing in accordance with Telcordia technical standards.
- (a) DS3 to DS1 multiplexing; and
- (b) DS1 to Voice/Base Rate/128-, 256-, 384-Kpbs Transport; multiplexing

- 6.3.11 If requested by Level 3, the following are available at the rates set forth in Exhibit C:
- 6.3.11.1 1 + 1 Protection for OC3 and OC12;
 - 6.3.11.2 1 + 1 Protection with Cable Survivability for OC3 and OC12;
 - 6.3.11.3 1 + 1 Protection with Route Survivability for OC3 and OC12.
- 6.3.12 Rates for Dedicated Transport are listed in Exhibit C to this Attachment.
- 6.3.13 Technical Requirements
- 6.3.13.1 This Section sets forth technical requirements for all Dedicated Transport.
- 6.3.13.2 When BellSouth provides Dedicated Transport, the entire designated transmission service (e.g., DS0, DS1, DS3, OCn) shall be dedicated to Level 3 designated traffic.
- 6.3.13.3 BellSouth shall offer Dedicated Transport in all technologies that are available and deployed in its network including but not limited to, (1) DS0, DS1, DS3, OC3, OC12, and OC 48 transport services, and (2) SONET at available transmission bit rates.
- 6.3.13.4 For DS1 or VT1.5 circuits, Dedicated Transport shall, at a minimum, meet the performance, availability, jitter, and delay requirements specified for Customer Interface to Central Office (“CI to CO”) connections in the appropriate industry standards.
- 6.3.13.5 Where applicable, for DS3, Dedicated Transport shall, at a minimum, meet the performance, availability, jitter, and delay requirements specified for CI to CO connections in the appropriate industry standards.
- 6.3.13.6 BellSouth shall offer the following interface transmission rates for Dedicated Transport:
- 6.3.13.6.1 DS0 Equivalent;
 - 6.3.13.6.2 DS1 (Extended SuperFrame - ESF);
 - 6.3.13.6.3 DS3 (signal must be framed);
 - 6.3.13.6.4 OCn (OC3, OC12, or OC48) (if and when available);
 - 6.3.13.6.5 SDH (Synchronous Digital Hierarchy) Standard interface rates in accordance with International Telecommunications Union (ITU) Recommendation G.707 and Plesiochronous Digital Hierarchy (PDH) rates per ITU Recommendation G.704.

6.3.13.6.6 When Dedicated Transport is provided, BellSouth shall design it according to BellSouth's network infrastructure to allow for the termination points specified by Level 3.

6.3.14 At a minimum, Dedicated Transport shall meet each of the requirements set forth in the applicable industry technical references.

6.3.14.1 BellSouth Technical References:

6.3.14.2 TR-TSY-000191 Alarm Indication Signals Requirements and Objectives, Issue 1, May 1986.

6.3.14.3 TR 73501 LightGate[®] Service Interface and Performance Specifications, Issue D, June 1995.

6.3.14.4 TR 73525 MegaLink[®] Service, MegaLink Channel Service & MegaLink Plus Service Interface and Performance Specifications, Issue C, May 1996.

6.4 Unbundled Channelization

6.4.1 BellSouth agrees to offer nondiscriminatory access to Unbundled Channelization when available pursuant to following terms and conditions and at the rates set forth in the Attachment.

6.4.2 Definition

6.4.2.1 Unbundled Channelization (UC) provides the multiplexing capability that will allow a DS1 (1.544 Mbps) or DS3 (44.736 Mbps) or STS-1 Unbundled Network Element (UNE) or collocation cross-connect to be multiplexed or channelized at a BellSouth central office. This can be accomplished through the use of a stand-alone multiplexer or a digital cross-connect system at the discretion of BellSouth. Once UC has been installed, Level 3 can have channels activated on an as-needed basis by having BellSouth connect lower level UNEs via Central Office Channel Interfaces (COICs).

6.4.3 Channelization capabilities will be as follows:

6.4.3.1 DS3 Channelization System: An element that channelizes a DS3 signal into 28 DS1s/STS-1s.

6.4.3.2 DS1 Channelization System: An element that channelizes a DS1 signal into 24 DS0s.

- 6.4.3.3 Central Office Channel Interfaces (COCI): Elements that can be activated on a channelization system.
- 6.4.4 DS1 Central Office Channel Interface elements can be activated on a DS3 Channelization System.
- 6.4.5 Voice Grade and Digital Data Central Office Channel Interfaces can be activated on a DS1 Channelization System.
- 6.4.6 AMI and B8ZS line coding with either Super Frame (SF) and Extended Super Frame (ESF) framing formats will be supported as options.
- 6.4.7 COCI will be billed on the lower level UNE order that is interfacing with the UC arrangement and will have to be compatible with those UNEs.
- 6.4.8 Channelization may be incorporated within dedicated transport or ordered as a stand-alone capability, which requires either the high or low speed side to be connected to collocation.
- 6.4.9 Technical Requirements
 - 6.4.9.1 In order to assure proper operation with BST provided central office multiplexing functionality, the customer's channelization equipment must adhere strictly to form and protocol standards. Separate standards exist for the multiplex channel bank, for voice frequency encoding, for various signaling schemes, and for subrate digital access.
 - 6.4.9.2 DS0 to DS1 Channelization
 - 6.4.9.2.1 The DS1 signal must be framed utilizing the framing structure defined in ANSI T1.107, *Digital Hierarchy Formats Specifications* and ANSI T1.403.02, *DS1 Robbed-bit Signaling State Definitions*. DS0 to DS1 Channelization requirements are essential the same as defined in BellSouth Technical Reference 73525, *MegaLink[®] Service, MegaLink[®] Channel Service, MegaLink[®] Plus Service, and MegaLink[®] Light Service Interface and Performance Specification*.
 - 6.4.9.3 DS1 to DS3 Channelization
 - 6.4.9.3.1 The DS3 signal must be framed utilizing the framing structure define in ANSI T1.107, *Digital Hierarchy Formats Specifications*. DS1 to DS3 Channelization requirements are essentially the same as defined in BellSouth Technical Reference 73501, *LightGate[®] Service Interface and Performance Specifications*. The asynchronous M13 multiplex format (combination of M12 and M23 formats) is specified for terminal equipment that multiplexes 28 DS1s into a DS3.

6.4.9.4 DS1 to STS Channelization

6.4.9.4.1 The STS-1 signal must be framed utilizing the framing structure define in ANSI T1.105, *Synchronous Optical Network (SONET) – Basic Description Including Multiplex Structure, Rates and Formats* and T1.105.02, *Synchronous Optical Network (SONET) – Payload Mappings*. DS1 to STS Channelization requirements are essentially the same as defined in BellSouth Technical Reference TR 73501, *LightGate® Service Interface and Performance Specifications*

6.5 Dark Fiber

6.5.1 Definition

6.5.2 Dark Fiber is an optical transmission facility without attached multiplexing, aggregation or other electronics that connects two points within BellSouth's network. Dark Fiber is unused strands of optical fiber. It may be strands of optical fiber existing in aerial or underground structure. No line terminating elements terminated to such strands to operationalize its transmission capabilities will be available. No regeneration or optical amplification will be included with this element.

6.5.3 Requirements

6.5.3.1 BellSouth shall make available Dark Fiber on a nondiscriminatory basis where it exists in BellSouth's network and where, as a result of future building or deployment, it becomes available. If BellSouth has pre-existing plans to make specific use of the fiber within a two –year planning period, there is no requirement to provide said fiber to Level 3, provided that upon Level 3's request, BellSouth shall provide written certification to Level 3 that BellSouth has plans to use such fiber and shall describe generally its plans to make such use, subject to Level 3's representative signing a separate confidentiality agreement with respect to the disclosure of such plans.

6.5.3.2 If the requested dark fiber has any lightwave repeater equipment interspliced to it, BellSouth will remove such equipment at Level 3's request subject to time and materials charges.

6.5.3.1 Level 3 may test the quality of the Dark Fiber to confirm its usability and performance specifications.

6.5.3.2 BellSouth shall use its best efforts to provide to Level 3 information regarding the location, availability and performance of Dark Fiber within ten (10) business days for a records based answer and twenty (20) business days for a field based answer, after receiving a request from Level 3 ("Request"). Within such time period, BellSouth shall send written confirmation of availability of the Dark Fiber ("Confirmation"). From the time of the Request to forty-five (45) days after Confirmation, BellSouth

shall hold such requested Dark Fiber for Level 3's use and may not allow any other party to use such media, including BellSouth.

- 6.5.3.3 BellSouth shall use its best efforts to make Dark Fiber available to Level 3 within thirty (30) business days after it receives written confirmation from Level 3 that the Dark Fiber previously deemed available by BellSouth is wanted for use by Level 3. This includes identification of appropriate connection points (e.g., Light Guide Interconnection (LGX) or splice points) to enable Level 3 to connect or splice Level 3 provided transmission media (e.g., optical fiber) or equipment to the Dark Fiber.
- 6.5.3.4 Dark Fiber shall meet the manufacturer's design specifications.
- 6.5.3.5 Level 3 may splice and test Dark Fiber obtained from BellSouth using Level 3 or Level 3 designated personnel. BellSouth shall provide appropriate interfaces to allow splicing and testing of Dark Fiber. BellSouth shall provide an excess cable length of 25 feet minimum (for fiber in underground conduit) to allow the uncoiled fiber to reach from the manhole to a splicing van.

6.6 Rates

- 6.6.1 The prices that Level 3 shall pay to BellSouth for Network Elements and Other Services are set forth in Exhibit C to this Attachment.

6.7 Operational Support Systems (OSS)

- 6.7.1 BellSouth has developed and made available the following mechanized systems by which Level 3 may submit LSRs electronically.

LENS	Local Exchange Navigation System
EDI	Electronic Data Interchange
TAG	Telecommunications Access Gateway

- 6.7.2 LSRs submitted by means of one of these interactive interfaces will incur an OSS electronic ordering charge as specified in the table below. An individual LSR will be identified for billing purposes by its Purchase Order Number (PON). LSRs submitted by means other than one of these interactive interfaces (mail, fax, courier, etc.) will incur a manual order charge as specified in the table below:

OPERATIONAL SUPPORT SYSTEMS	AL, GA, LA, NC, MS, SC	FL, KY, TN
-----------------------------	---------------------------	------------

OSS LSR charge, per LSR received from the CLEC by one of the OSS interactive interfaces	\$3.50 SOMEK	\$3.50 SOMEK
Incremental charge per LSR received from the CLEC by means other than one of the OSS interactive interfaces	See applicable rate element	\$19.99 SOMAN

6.7.3 Denial/Restoral OSS Charge

6.7.3.1 In the event Level 3 provides a list of customers to be denied and restored, rather than an LSR, each location on the list will require a separate PON and, therefore will be billed as one LSR per location.

6.7.4 Cancellation OSS Charge

6.7.4.1 Level 3 will incur an OSS charge for an accepted LSR that is later canceled by Level 3.

Note: Supplements or clarifications to a previously billed LSR will not incur another OSS charge.

6.7.5 Network Elements and Other Services Manual Additive

6.7.5.1 The Commissions in some states have ordered per-element manual additive non-recurring charges (NRC) for Network Elements and Other Services ordered by means other than one of the interactive interfaces. These ordered Network Elements and Other Services manual additive NRCs will apply in these states, rather than the charge per LSR. The per-element charges are listed on the Rate Tables in Exhibit A.

7. BellSouth SWA 8XX Toll Free Dialing Ten Digit Screening Service

All of the negotiated rates, terms and conditions set forth in this Section pertain to the provision of 8XX Access Ten Digit Screening Services.

7.1 BellSouth SWA 8XX Toll Free Dialing Ten Digit Screening Service database

7.1.1 The BellSouth SWA 8XX Toll Free Dialing Ten Digit Screening Service database (herein known as 8XX SCP) is a SCP that contains customer record information and functionality to provide call-handling instructions for 8XX calls. The 8XX SCP IN software stores data downloaded from the national SMS and provides the routing instructions in response to queries from the SSP or tandem. The BellSouth SWA 8XX Toll Free Dialing Ten Digit Screening Service (herein know as 8XX TFD), utilizes the 8XX SCP to provide identification and routing of the 8XX calls, based on the ten digits dialed. 8XX TFD is provided with or without POTS number delivery, dialing number delivery, and other optional complex features as selected by Level 3. BellSouth shall provide 8XX TFD in accordance with the following:

7.1.2 Technical Requirements

7.1.2.1 BellSouth shall provide Level 3 with nondiscriminatory access to the 8XX record information located in the 8XX SCP. The 8XX SCP contains current records as received from the national SMS and will provide for routing 8XX originating calls based on the dialed ten digit 8XX number.

7.1.2.2 The 8XX SCP is designated to receive and respond to queries using the American National Standard Specification of Signaling System Seven (SS7) protocol. The 8XX SCP shall determine the carrier identification based on all ten digits of the dialed number and route calls to the carrier, POTS number, dialing number and/or other optional feature selected by Level 3.

7.1.2.3 The SCP shall also provide, at Level 3's option, such additional feature as described in SR-TSV-002275 (BOC Notes on BellSouth Networks, SR-TSV-002275, Issue 2, (Telcordia (formerly BellCore), April 1994)) as are available to BellSouth. These may include but are not limited to:

7.1.2.3.1 Network Management;

7.1.2.3.2 Customer Sample Collection; and

7.1.2.3.3 Service Maintenance.

7.2 Rates

The prices that Level 3 shall pay to BellSouth for Network Elements and Other Services are set forth in Exhibit C to this Attachment.

8 Line Information Database (LIDB)

8.1 All of the negotiated rates, terms and conditions set forth in this Section pertain to the provision of LIDB.

8.2 BellSouth will store in its LIDB only records relating to service in the BellSouth region. The LIDB Storage Agreement is included in this Attachment.

8.2.1 Definition

8.2.2 The Line Information Database (LIDB) is a transaction-oriented database accessible through Common Channel Signaling (CCS) networks. It contains records associated with end user Line Numbers and Special Billing Numbers. LIDB accepts queries from other Network Elements and provides appropriate responses. The query originator need not be the owner of LIDB data. LIDB queries include functions such as screening billed numbers that provides the ability to accept Collect or Third Number Billing calls and validation of Telephone Line Number based non-proprietary calling cards. The interface for the LIDB functionality is the interface between BellSouth's CCS network and other CCS networks. LIDB also interfaces to administrative systems.

8.2.3 Technical Requirements

8.2.4 BellSouth will offer to Level 3 any additional capabilities that are developed for LIDB during the life of this Agreement.

8.2.4.1 BellSouth shall process Level 3's Customer records in LIDB at least at parity with BellSouth customer records, with respect to other LIDB functions. BellSouth shall indicate to Level 3 what additional functions (if any) are performed by LIDB in the BellSouth network.

8.2.4.2 Within two (2) weeks after a request by Level 3, BellSouth shall provide Level 3 with a list of the customer data items, which Level 3 would have to provide in order to support each required LIDB function. The list shall indicate which data items are essential to LIDB function, and which are required only to support certain services. For each data item, the list shall show the data formats, the acceptable values of the data item and the meaning of those values.

8.2.4.3 BellSouth shall provide LIDB systems for which operating deficiencies that would result in calls being blocked shall not exceed 30 minutes per year.

8.2.4.4 BellSouth shall provide LIDB systems for which operating deficiencies that would not result in calls being blocked shall not exceed 12 hours per year.

- 8.2.4.5 BellSouth shall provide LIDB systems for which the LIDB function shall be in overload no more than 12 hours per year.
- 8.2.4.6 All additions, updates and deletions of Level 3 data to the LIDB shall be solely at the direction of Level 3. Such direction from Level 3 will not be required where the addition, update or deletion is necessary to perform standard fraud control measures (e.g., calling card auto-deactivation).
- 8.2.4.7 BellSouth shall provide priority updates to LIDB for Level 3 data upon Level 3's request (e.g., to support fraud detection), via password-protected telephone card, facsimile, or electronic mail within one hour of notice from the established BellSouth contact.
- 8.2.4.8 BellSouth shall provide LIDB systems such that no more than 0.01% of Level 3 customer records will be missing from LIDB, as measured by Level 3 audits. BellSouth will audit Level 3 records in LIDB against DBAS to identify record mismatches and provide this data to a designated Level 3 contact person to resolve the status of the records and BellSouth will update system appropriately. BellSouth will refer record of mis-matches to Level 3 within one business day of audit. Once reconciled records are received back from Level 3, BellSouth will update LIDB the same business day if less than 500 records are received before 1:00PM Central Time. If more than 500 records are received, BellSouth will contact Level 3 to negotiate a time frame for the updates, not to exceed three business days.
- 8.2.4.9 BellSouth shall perform backup and recovery of all of Level 3's data in LIDB including sending to LIDB all changes made since the date of the most recent backup copy, in at least the same time frame BellSouth performs backup and recovery of BellSouth data in LIDB for itself. Currently, BellSouth performs backups of the LIDB for itself on a weekly basis and when a new software release is scheduled, a backup is performed prior to loading the new release.
- 8.2.4.10 BellSouth shall provide Level 3 with LIDB reports of data, which are missing or contain errors, as well as any misrouted errors, within a reasonable time period as negotiated between Level 3 and BellSouth.
- 8.2.4.11 BellSouth shall prevent any access to or use of Level 3 data in LIDB by BellSouth personnel that are outside of established administrative and fraud control personnel, or by any other Party that is not authorized by Level 3 in writing.
- 8.2.4.12 BellSouth shall provide Level 3 performance of the LIDB Data Screening function, which allows a LIDB to completely or partially deny specific query originators access to LIDB data owned by specific data owners, for Customer Data that is part of an NPA-NXX or RAO-0/1XX wholly or partially owned by Level 3 at least at parity with BellSouth Customer Data. BellSouth shall obtain from Level 3 the screening

information associated with LIDB Data Screening of Level 3 data in accordance with this requirement. BellSouth currently does not have LIDB Data Screening capabilities. When such capability is available, BellSouth shall offer it to Level 3 under the Bona Fide Request/New Business Process as set forth in General Terms and Conditions.

- 8.2.4.13 BellSouth shall accept queries to LIDB associated with Level 3 customer records, and shall return responses in accordance with industry standards.
- 8.2.4.14 BellSouth shall provide mean processing time at the LIDB within 0.50 seconds under normal conditions as defined in industry standards.
- 8.2.4.15 BellSouth shall provide processing time at the LIDB within 1 second for 99% of all messages under normal conditions as defined in industry standards.

8.2.5 Interface Requirements

8.2.6 BellSouth shall offer LIDB in accordance with the requirements of this subsection.

8.2.6.1 The interface to LIDB shall be in accordance with the technical references contained within.

8.2.6.2 The CCS interface to LIDB shall be the standard interface described herein.

8.2.6.3 The LIDB Data Base interpretation of the ANSI-TCAP messages shall comply with the technical reference herein. Global Title Translation shall be maintained in the signaling network in order to support signaling network routing to the LIDB.

8.3 **Rates**

The prices that Level 3 shall pay to BellSouth for Network Elements and Other Services are set forth in Exhibit C to this Attachment.

9 Signaling

9.1 All of the negotiated rates, terms and conditions set forth in this Section pertain to the provision of Signaling Transport Services.

9.2 BellSouth shall offer nondiscriminatory access to signaling and access to BellSouth's signaling systems and databases subject to compatibility testing and at the rates set forth in this Attachment. Available signaling elements include signaling links, signal transfer points and service control points. Signaling functionality will be available with both A-link and B-link connectivity.

9.3 Signaling Link Transport

9.3.1 Definition Signaling Link Transport is a set of two or four dedicated 56 Kbps., or other agreed upon speeds, transmission paths between CLEC-designated Signaling Points of Interconnection (SPOI) that provides appropriate physical diversity.

9.3.2 Technical Requirements

9.3.2.1 Signaling Link Transport shall consist of full duplex mode 56 kbps transmission paths or other agreed upon speeds.

9.3.3 Of the various options available, Signaling Link Transport shall perform in the following two ways:

9.3.3.1 As an "A-link" which is a connection between a switch or SCP and a home Signaling Transfer Point Switch (STP) pair; and

9.3.3.2 As a "B-link" (also known as a "D-link") which is a connection between two STP pairs in different company networks (e.g., between two STP pairs for two Competitive Local Exchange Carriers (CLECs)).

9.3.4 Signaling Link Transport shall consist of two or more signaling link layers as follows:

9.3.4.1 An A-link layer shall consist of two links.

9.3.4.2 A B-link layer shall consist of four links.

9.3.5 A signaling link layer shall satisfy a performance objective such that:

9.3.5.1 There shall be no more than two minutes down time per year for an A-link layer; and

9.3.5.2 There shall be negligible (less than 2 seconds) down time per year for a B-link layer.

- 9.3.5.3 A signaling link layer shall satisfy interoffice and intraoffice diversity of facilities and equipment, such that:
- 9.3.5.3.1 No single failure of facilities or equipment causes the failure of both links in an A-link layer (i.e., the links should be provided on a minimum of two separate physical paths end-to-end); and
- 9.3.5.3.2 No two concurrent failures of facilities or equipment shall cause the failure of all four links in a B-link layer (i.e., the links should be provided on a minimum of three separate physical paths end-to-end).
- 9.3.5.4 Interface Requirements
- 9.3.5.4.1 There shall be a DS1 (1.544 Mbps) interface, or other agreed upon interface, at the Level 3 designated SPOIs. Each 56 kbps transmission path shall appear as a DS0 channel within the DS1 interface.

9.4 Signaling Transfer Points (STPs)

- 9.4.1 Definition - Signaling Transfer Points is a signaling network function that includes all of the capabilities provided by the signaling transfer point switches (STPs) and their associated signaling links which enable the exchange of SS7 messages among and between switching elements, database elements and signaling transfer point switches.
- 9.4.2 Technical Requirements
- 9.4.2.1 STPs shall provide access to Network Elements connected to BellSouth SS7 network. These include:
- 9.4.2.1.1 BellSouth Local Switching or Tandem Switching;
- 9.4.2.1.2 BellSouth Service Control Points/DataBases;
- 9.4.2.1.3 Third-party local or tandem switching;
- 9.4.2.1.4 Third-party-provided STPs.
- 9.4.2.2 The connectivity provided by STPs shall fully support the functions of all other Network Elements connected to the BellSouth SS7 network. This explicitly includes the use of the BellSouth SS7 network to convey messages which neither originate nor terminate at a signaling end point directly connected to the BellSouth SS7 network (i.e., transient messages). When the BellSouth SS7 network is used to convey transient messages, there shall be no alteration of the Integrated Services Digital Network User Part (ISUP) or Transaction Capabilities Application Part (TCAP) user data that constitutes the content of the message.

- 9.4.2.3 If a BellSouth tandem switch routes calling traffic, based on dialed or translated digits, on SS7 trunks between an Level 3 local switch and third party local switch, the BellSouth SS7 network shall convey the TCAP messages that are necessary to provide Call Management features (Automatic Callback, Automatic Recall, and Screening List Editing) between Level 3 local STPs and the STPs that provide connectivity with the third party local switch, even if the third party local switch is not directly connected to BellSouth STPs.
- 9.4.2.4 STPs shall provide all functions of the MTP as defined in the applicable industry standard technical references.
- 9.4.2.5 STPs shall provide all functions of the SCCP necessary for Class 0 (basic connectionless) service, as defined in Telcordia (formerly BellCore) ANSI Interconnection Requirements. In particular, this includes Global Title Translation (GTT) and SCCP Management procedures, as specified in T1.112.4. In cases where the destination signaling point is a Level 3 or third party local or tandem switching system directly connected to BellSouth SS7 network, BellSouth shall perform final GTT of messages to the destination and SCCP Subsystem Management of the destination. In all other cases, BellSouth shall perform intermediate GTT of messages to a gateway pair of STPs in an SS7 network connected with BellSouth SS7 network, and shall not perform SCCP Subsystem Management of the destination. If BellSouth performs final GTT to a Level 3 database, then Level 3 agrees to provide BellSouth with the Destination Point Code for the Level 3 database.
- 9.4.2.6 STPs shall provide on a non-discriminatory basis all functions of the OMAP commonly provided by STPs, as specified in ANSI T1.116-1990 American National Standards for Telecommunications – Signaling System No. 7 (SS7) – Operations, Maintenance, and Administration Part (OMAP). All OMAP functions will be on a "where available" basis and can include:
- 9.4.2.6.1 MTP Routing Verification Test (MRVT); and
- 9.4.2.6.2 SCCP Routing Verification Test (SRVT).
- 9.4.2.7 In cases where the destination signaling point is a BellSouth local or tandem switching system or database, or is an Level 3 or third party local or tandem switching system directly connected to the BellSouth SS7 network, STPs shall perform MRVT and SRVT to the destination signaling point. In all other cases, STPs shall perform MRVT and SRVT to a gateway pair of STPs in an SS7 network connected with the BellSouth SS7 network. This requirement shall be superseded by the specifications for Internetwork MRVT and SRVT if and when these become approved ANSI standards and available capabilities of BellSouth STPs, and if mutually agreed upon by Level 3 and BellSouth.

9.4.2.8 STPs shall be provided at parity.

9.4.2.9 SS7 Advanced Intelligent Network (AIN) Access

9.4.2.9.1 When technically feasible and upon request by Level 3, SS7 Access shall be made available in association with switching. SS7 AIN Access is the provisioning of AIN 0.1 triggers in an equipped BellSouth local switch and interconnection of the BellSouth SS7 network with the Level 3 SS7 network to exchange TCAP queries and responses with an Level 3 SCP.

9.4.2.9.2 SS7 AIN Access shall provide Level 3 SCP access to BellSouth local switch in association with switching via interconnection of BellSouth SS7 and Level 3 SS7 Networks. BellSouth shall offer SS7 access through its STPs. If BellSouth requires a mediation device on any part of its network specific to this form of access, BellSouth must route its messages in the same manner. The interconnection arrangement shall result in the BellSouth local switch recognizing the Level 3 SCP as at least at parity with BellSouth's SCP's in terms of interfaces, performance and capabilities.

9.4.3 Interface Requirements

9.4.3.1 BellSouth shall provide the following STPs options to connect Level 3 or Level 3-designated local switching systems or STPs to the BellSouth SS7 network:

9.4.3.1.1 An A-link interface from Level 3 local switching systems; and,

9.4.3.1.2 A B-link interface from Level 3 local STPs.

9.4.3.2 Each type of interface shall be provided by one or more sets (layers) of signaling links.

9.4.3.3 The Signaling Point of Interconnection (SPOI) for each link shall be located at a cross-connect element, such as a DSX-1, in the Central Office (CO) where BellSouth STP is located. There shall be a DS1 or higher rate transport interface at each of the SPOIs. Each signaling link shall appear as a DS0 channel within the DS1 or higher rate interface. BellSouth shall offer higher rate DS1 signaling for interconnecting Level 3 local switching systems or STPs with BellSouth STPs as soon as these become approved ANSI standards and available capabilities of BellSouth STPs. BellSouth and Level 3 will work jointly to establish mutually acceptable SPOIs.

9.4.3.4 BellSouth CO shall provide intraoffice diversity between the SPOIs and BellSouth STPs, so that no single failure of intraoffice facilities or equipment shall cause the failure of both B-links in a layer connecting to a BellSouth STP. BellSouth and Level 3 will work jointly to establish mutually acceptable SPOIs.

9.4.3.5 STPs shall provide all functions of the MTP as defined in the applicable industry standard technical references.

9.4.3.6 Message Screening

9.4.3.6.1 BellSouth shall set message screening parameters so as to accept valid messages from Level 3 local or tandem switching systems destined to any signaling point within BellSouth's SS7 network where the Level 3 switching system has a legitimate signaling relation.

9.4.3.6.2 BellSouth shall set message screening parameters so as to pass valid messages from Level 3 local or tandem switching systems destined to any signaling point or network accessed through BellSouth's SS7 network where the Level 3 switching system has a legitimate signaling relation.

9.4.3.6.3 BellSouth shall set message screening parameters so as to accept and pass/send valid messages destined to and from Level 3 from any signaling point or network interconnected through BellSouth's SS7 network where the Level 3 SCP has a legitimate signaling relation.

9.4.4 STPs shall be equal to or better than all of the requirements for STPs set forth in the applicable industry standard technical references.

9.5 Service Control Points/Databases

9.5.1 Definition

9.5.1.1 Databases are the Network Elements that provide the functionality for storage of, access to, and manipulation of information required to offer a particular service and/or capability. Databases include, but are not limited to: Local Number Portability, LIDB, Toll Free Number Database, Automatic Location Identification/Data Management System, Calling Name Database, access to Service Creation Environment and Service Management System (SCE/SMS) application databases and Directory Assistance.

9.5.2 A Service Control Point (SCP) is a specific type of Database functionality deployed in a Signaling System 7 (SS7) network that executes service application logic in response to SS7 queries sent to it by a switching system also connected to the SS7 network. Service Management Systems provide operational interfaces to allow for provisioning, administration and maintenance of subscriber data and service application data stored in SCPs.

9.5.3 Technical Requirements for SCPs/Databases

9.5.3.1 Requirements for SCPs/Databases within this section address storage of information, access to information (e.g. signaling protocols, response times), and administration of information (e.g., provisioning, administration, and maintenance). All SCPs/Databases shall be provided to Level 3 in accordance with the following requirements.

- 9.5.3.2 BellSouth shall provide physical access to SCPs through the SS7 network and protocols with TCAP as the application layer protocol.
- 9.5.3.3 BellSouth shall provide physical interconnection to databases via industry standard interfaces and protocols (e.g. SS7, ISDN and X.25).
- 9.5.3.4 The reliability of interconnection options shall be consistent with requirements for diversity and survivability.
- 9.5.4 Database Availability
- 9.5.4.1 Call processing databases shall have a maximum unscheduled availability of 30 minutes per year. Unavailability due to software and hardware upgrades shall be scheduled during minimal usage periods and only be undertaken upon proper notification to providers, which might be impacted. Any downtime associated with the provision of call processing related databases will impact all service providers, including BellSouth, equally.
- 9.5.4.2 The operational interface provided by BellSouth shall complete Database transactions (i.e., add, modify, delete) for Level 3 customer records stored in BellSouth databases within 3 days, or sooner where BellSouth provisions its own customer records within a shorter interval.

9.6 Local Number Portability Database

9.6.1 Definition

- 9.6.2 The Permanent Number Portability (PNP) database supplies routing numbers for calls involving numbers that have been ported from one local service provider to another. PNP is currently being worked in industry forums. The results of these forums will dictate the industry direction of PNP. BellSouth agrees to provide access to the PNP database at rates, terms and conditions as set forth by BellSouth and in accordance with an effective FCC or Commission directive.

9.7 SS7 Network Interconnection

9.7.1 Definition.

- 9.7.2 SS7 Network Interconnection is the interconnection of Level 3 local Signaling Transfer Point Switches (STP) and Level 3 local or tandem switching systems with BellSouth STPs. This interconnection provides connectivity that enables the exchange of SS7 messages among BellSouth switching systems and databases (DBs), Level 3 local or tandem switching systems, and other third-party switching systems directly connected to the BellSouth SS7 network.

9.7.3 Technical Requirements

- 9.7.3.1 SS7 Network Interconnection shall provide connectivity to all components of the BellSouth SS7 network. These include:
- 9.7.3.1.1 BellSouth local or tandem switching systems;
 - 9.7.3.1.2 BellSouth DBs; and
 - 9.7.3.1.3 Other third-party local or tandem switching systems.
- 9.7.4 The connectivity provided by SS7 Network Interconnection shall fully support the functions of BellSouth switching systems and DBs and Level 3 or other third-party switching systems with A-link access to the BellSouth SS7 network.
- 9.7.5 If traffic is routed based on dialed or translated digits between an Level 3 local switching system and a BellSouth or other third-party local switching system, either directly or via a BellSouth tandem switching system, then it is a requirement that the BellSouth SS7 network convey via SS7 Network Interconnection the TCAP messages that are necessary to provide Call Management services (Automatic Callback, Automatic Recall, and Screening List Editing) between the Level 3 local STPs and BellSouth or other third-party local switch.
- 9.7.6 When the capability to route messages based on Intermediate Signaling Network Identifier (ISNI) is generally available on BellSouth STPs, the BellSouth SS7 Network shall also convey TCAP messages using SS7 Network Interconnection in similar circumstances where the BellSouth switch routes traffic based on a Carrier Identification Code (CIC).
- 9.7.7 SS7 Network Interconnection shall provide all functions of the MTP as specified in ANSI T1.111. This includes:
- 9.7.7.1 Signaling Data Link functions, as specified in ANSI T1.111.2;
 - 9.7.7.2 Signaling Link functions, as specified in ANSI T1.111.3; and
 - 9.7.7.3 Signaling Network Management functions, as specified in ANSI T1.111.4.
- 9.7.8 SS7 Network Interconnection shall provide all functions of the SCCP necessary for Class 0 (basic connectionless) service, as specified in ANSI T1.112. In particular, this includes Global Title Translation (GTT) and SCCP Management procedures, as specified in T1.112.4. Where the destination signaling point is a BellSouth switching system or DB, or is another third-party local or tandem switching system directly connected to the BellSouth SS7 network, SS7 Network Interconnection shall include final GTT of messages to the destination and SCCP Subsystem Management of the destination. Where the destination signaling point is an Level 3 local or tandem switching system, SS7 Network Interconnection shall include intermediate GTT of

- messages to a gateway pair of Level 3 local STPs, and shall not include SCCP Subsystem Management of the destination.
- 9.7.9 SS7 Network Interconnection shall provide all functions of the Integrated Services Digital Network User Part (ISUP), as specified in ANSI T1.113.
- 9.7.10 SS7 Network Interconnection shall provide all functions of the TCAP, as specified in ANSI T1.114.
- 9.7.11 If and when Internetwork MTP Routing Verification Test (MRVT) and SCCP Routing Verification Test (SRVT) become approved ANSI standards and available capabilities of BellSouth STPs, SS7 Network Interconnection shall provide these functions of the OMAP.
- 9.7.12 SS7 Network Interconnection shall be equal to or better than the following performance requirements:
- 9.7.12.1 MTP Performance, as specified in ANSI T1.111.6;
- 9.7.12.2 SCCP Performance, as specified in ANSI T1.112.5; and
- 9.7.12.3 ISUP Performance, as specified in ANSI T1.113.5.
- 9.7.13 Interface Requirements
- 9.7.13.1 BellSouth shall offer the following SS7 Network Interconnection options to connect Level 3 or Level 3-designated local or tandem switching systems or STPs to the BellSouth SS7 network:
- 9.7.13.1.1 A-link interface from Level 3 local or tandem switching systems; and
- 9.7.13.1.2 B-link interface from Level 3 STPs.
- 9.7.13.2 The Signaling Point of Interconnection (SPOI) for each link shall be located at a cross-connect element, such as a DSX-1, in the Central Office (CO) where the BellSouth STP is located. There shall be a DS1 or higher rate transport interface at each of the SPOIs. Each signaling link shall appear as a DS0 channel within the DS1 or higher rate interface. BellSouth shall offer higher rate DS1 signaling links for interconnecting Level 3 local switching systems or STPs with BellSouth STPs as soon as these become approved ANSI standards and available capabilities of BellSouth STPs. BellSouth and Level 3 will work jointly to establish mutually acceptable SPOI.
- 9.7.13.3 BellSouth CO shall provide intraoffice diversity between the SPOIs and the BellSouth STP, so that no single failure of intraoffice facilities or equipment shall cause the

- failure of both B-links in a layer connecting to a BellSouth STP. BellSouth and Level 3 will work jointly to establish mutually acceptable SPOI.
- 9.7.13.4 The protocol interface requirements for SS7 Network Interconnection include the MTP, ISUP, SCCP, and TCAP. These protocol interfaces shall conform to the applicable industry standard technical references.
- 9.7.13.5 BellSouth shall set message screening parameters to accept messages from Level 3 local or tandem switching systems destined to any signaling point in the BellSouth SS7 network with which the Level 3 switching system has a legitimate signaling relation.
- 9.7.13.6 SS7 Network Interconnection shall be equal to or better than all of the requirements for SS7 Network Interconnection set forth in the applicable industry standard technical references.

9.8 Rates

The prices that Level 3 shall pay to BellSouth for Network Elements and Other Services are set forth in Exhibit C to this Attachment.

10. Operator Call Processing, Inward Operator Services and Directory Assistance Services

10.1 All of the negotiated rates, terms and conditions set forth in this Section pertain to the provision of Operator Call Processing, Inward Operator Services and Directory Assistance Services.

10.2 Operator Systems

10.2.1 Definition. Operator Systems is the Network Element that provides operator and automated call handling and billing, special services, end user telephone listings and optional call completion services. The Operator Systems, Network Element provides two types of functions: Operator Service functions and Directory Assistance Service functions, each of which are described in detail below.

10.3 Operator Service

10.3.1 Definition. Operator Service provides: (1) operator handling for call completion (for example, collect, third number billing, and manual credit card calls), (2) operator or automated assistance for billing after the end user has dialed the called number (for example, credit card calls); and (3) special services including but not limited to Busy Line Verification and Emergency Line Interrupt (ELI), Emergency Agency Call, Operator-assisted Directory Assistance, and Rate Quotes.

10.3.2 Requirements

10.3.2.1 When Level 3 requests BellSouth to provide Operator Services, the following requirements apply:

10.3.2.1.1 BellSouth shall complete 0+ and 0- dialed local calls.

10.3.2.1.2 BellSouth shall complete 0+ intraLATA toll calls.

10.3.2.1.3 BellSouth shall process calls that are billed to Level 3 end user's calling card that can be validated by BellSouth.

10.3.2.1.4 BellSouth shall complete person-to-person calls.

10.3.2.1.5 BellSouth shall complete collect calls.

10.3.2.1.6 BellSouth shall provide the capability for callers to bill to a third party and complete such calls.

10.3.2.1.7 BellSouth shall complete station-to-station calls.

- 10.3.2.1.8 BellSouth shall process emergency calls.
- 10.3.2.1.9 BellSouth shall process Busy Line Verify and Emergency Line Interrupt requests.
- 10.3.2.1.10 BellSouth shall process emergency call trace, as they do for their End users prior to the Effective Date. Call must originate from a 911 provider.
- 10.3.2.1.11 BellSouth shall process operator-assisted directory assistance calls.
- 10.3.2.1.12 BellSouth shall adhere to equal access requirements, providing Level 3 local end users the same IXC access as provided to BellSouth end users.
- 10.3.2.1.13 BellSouth shall exercise at least the same level of fraud control in providing Operator Service to Level 3 that BellSouth provides for its own operator service.
- 10.3.2.1.14 BellSouth shall perform Billed Number Screening when handling Collect, Person-to-Person, and Billed-to-Third-Party calls.
- 10.3.2.1.15 BellSouth shall direct customer account and other similar inquiries to the customer service center designated by Level 3.
- 10.3.2.1.16 BellSouth shall provide a feed of customer call records in “EMI” format to Level 3 in accordance with CLEC ODUF standards specified in Attachment 7.

10.3.3 Interface Requirements

- 10.3.3.1 With respect to Operator Services for calls that originate on local switching capability provided by or on behalf of Level 3, the interface requirements shall conform to the then current established system interface specifications for the platform used to provide Operator Service and the interface shall conform to industry standards.

10.4 **Directory Assistance Service**

- 10.4.1 Definition. Directory Assistance Service provides local end user telephone number listings with the option to complete the call at the callers direction separate and distinct from local switching.
- 10.4.2 Requirements
- 10.4.3 Directory Assistance Service shall provide up to two listing requests per call. If available and if requested by Level 3’s end user, BellSouth shall provide caller-optional directory assistance call completion service at rates contained in this Attachment to one of the provided listings, equal to that which BellSouth provides its end users. If not available, Level 3 may request such requirement pursuant to the Bona Fide Request/New Business Process as set forth in General Terms and Conditions.
- 10.4.4 Directory Assistance Service Updates

- 10.4.4.1 BellSouth shall update end user listings changes daily. These changes include:
 - 10.4.4.1.1 New end user connections: BellSouth will provide service to Level 3 that is equal to the service it provides to itself and its end users;
 - 10.4.4.1.2 End user disconnections: BellSouth will provide service to Level 3 that is equal to the service it provides to itself and its end users; and
 - 10.4.4.1.3 End user address changes: BellSouth will provide service to Level 3 that is equal to the service it provides to itself and its end users;
 - 10.4.4.1.4 These updates shall also be provided for non-listed and non-published numbers for use in emergencies.

10.4.5 Branding for Operator Call Processing and Directory Assistance

- 10.4.5.1 The BellSouth Operator Systems Branding Feature provides a definable announcement to Level 3 end users using Directory Assistance (DA)/Operator Call Processing (OCP) prior to placing them in queue or connecting them to an available operator or automated operator system. This feature allows Level 3 to have its calls custom branded with Level 3's name on whose behalf BellSouth is providing Directory Assistance and/or Operator Call Processing. Rates for Custom Branding, Operator Call Process and Directory Assistance are set forth in this Attachment.
- 10.4.5.2 BellSouth offers four service levels of branding to Level 3 when ordering Directory Assistance and/or Operator Call Processing.
 - 10.4.5.2.1 Service Level 1 - BellSouth Branding
 - 10.4.5.2.2 Service Level 2 - Unbranded
 - 10.4.5.2.3 Service Level 3 - Custom Branding
 - 10.4.5.2.4 Service Level 4 - Self Branding (applicable only to Level 3 for Resale or use with an Unbundled Port when routing to an operator service provider other than BellSouth).

10.4.6 For Resellers and Use with an Unbundled Port

- 10.4.6.1 BellSouth Branding is the Default Service Level.
- 10.4.6.2 Unbranding, Custom Branding, and Self Branding require Level 3 to order selective routing for each originating BellSouth end office identified by Level 3. Rates for Selective Routing are set forth in this Attachment.

- 10.4.6.3 Customer Branding and Self Branding require Level 3 to order dedicated trunking from each BellSouth end office identified by Level 3, to either the BellSouth Traffic Operator Position System (TOPS) or Level 3 Operator Service Provider. Rates for trunks are set forth in applicable BellSouth tariffs.
- 10.4.6.4 Unbranding - Unbranded Directory Assistance and/or Operator Call Processing calls ride common trunk groups provisioned by BellSouth from those end offices identified by Level 3 to the BellSouth TOPS. These calls are routed to "No Announcement."
- 10.4.7 For Facilities Based Carriers
 - 10.4.7.1 All Service Levels require Level 3 to order dedicated trunking from their end office(s) point of interface to the BellSouth TOPS Switches. Rates for trunks are set forth in applicable BellSouth tariffs.
 - 10.4.7.2 Customized Branding includes charges for the recording of the branding announcement and the loading of the audio units in each TOPS Switch, IVS and NAV equipment for which Level 3 requires service.
- 10.4.8 Directory Assistance customized branding uses:
 - 10.4.8.1 the recording of the name;
 - 10.4.8.2 the front-end loading of the Digital Recorded Announcement Machine (DRAM) in each TOPS switch.
- 10.4.9 Operator Call Processing customized branding uses:
 - 10.4.9.1 the recording of the name;
 - 10.4.9.2 the front-end loading of the DRAM in the TOPS Switch;
 - 10.4.9.3 the back-end loading in the audio units in the Automated Alternate Billing System (AABS) in the Interactive Voice Subsystem (IVS);
 - 10.4.9.4 the 0- automation loading for the audio units in the Enhanced Billing and Access Service (EBAS) in the Network Applications Vehicle (NAV).
 - 10.4.9.5 BellSouth will provide to Level 3 purchasing local BellSouth switching and reselling BellSouth local exchange service, selective routing of calls to a requested directory assistance services platform or operator services platform. Level 3 end users may use the same dialing arrangements as BellSouth end users, but obtain a Level 3 branded service.

10.5 Directory Assistance Database Service (DADS)

- 10.5.1 BellSouth shall make its Directory Assistance Database Service (DADS) available solely for the expressed purpose of providing Directory Assistance type services to Level 3 end users. The term “end user” denotes any entity which obtains Directory Assistance type services for its own use from a DADS customer. Directory Assistance type service is defined as Voice Directory Assistance (DA Operator assisted and Electronic Directory Assistance (Data System assisted)). Level 3 agrees that Directory Assistance Database Service (DADS) will not be used for any purpose which violates federal or state laws, statutes, regulatory orders or tariffs. Except for the permitted users, Level 3 agrees not to disclose DADS to others and shall provide due care in providing for the security and confidentiality of DADS. Further, Level 3 authorizes the inclusion of Level 3 Directory Assistance listings in the BellSouth Directory Assistance products.
- 10.5.2 BellSouth shall provide Level 3 initially with a base file of subscriber listings which reflect all listing change activity occurring since Level 3’s most recent update via magnetic tape, and subsequently using electronic connectivity such as Network Data Mover to be developed mutually by Level 3 and BellSouth. Level 3 agrees to assume the costs associated with CONNECT: Direct™ connectivity, which will vary depending upon volume and mileage.
- 10.5.3 BellSouth will require approximately one month after receiving an order to prepare the Base File. BellSouth will provide daily updates which will reflect all listing change activity occurring since CLEC’s most recent update. BellSouth shall provide updates to Level 3 on a Business, Residence, or combined Business and Residence basis. Level 3 agrees that the updates shall be used solely to keep the information current. Delivery of Daily Updates will commence the day after Level 3 receives the Base File.
- 10.5.4 BellSouth is authorized to include Level 3 Directory Assistance Listing Information in its Directory Assistance Database Service (DADS). Any other use by BellSouth of Level 3 Directory Assistance Listing Information is not authorized and with the exception of a request for DADS, BellSouth shall refer any request for such information to Level 3.
- 10.5.5 Rates for DADS are as set forth in this Attachment.

10.6 Direct Access to Directory Assistance Service

- 10.6.1 Direct Access to Directory Assistance Service (DADAS) will provide Level 3’s directory assistance operators with the ability to search all available BellSouth’s subscriber listings using the Directory Assistance search format. Subscription to DADAS will allow Level 3 to utilize its own switch, operator workstations and optional audio subsystems.

- 10.6.2 BellSouth will provide DADAS from its DA location. Level 3 will access the DADAS system via a telephone company provided point of availability. Level 3 has the responsibility of providing the physical links required to connect to the point of availability. These facilities may be purchased from the telephone company as rates and charges billed separately from the charges associated with this offering.
- 10.6.3 A specified interface to each Level 3 subsystem will be provided by BellSouth. Interconnection between Level 3's system and a specified BellSouth location will be pursuant to the use of Level 3 owned or Level 3 leased facilities and shall be appropriate sized based upon the volume of queries being generated by Level 3.
- 10.6.4 The specifications for the three interfaces necessary for interconnection are available in the following documents:
- 10.6.4.1 DADAS to Subscriber Operator Position System—Northern Telecom Document CSI-2300-07; Universal Gateway/ Position Message Interface Format Specification;
- 10.6.4.2 DADAS to Subscriber Switch—Northern Telecom Document Q210-1 Version A107; NTDMS/CCIDAS System Application Protocol; and AT&T Document 250-900-535 Operator Services Position System Listing Service and Application Call Processing Data Link Interface Specification;
- 10.6.4.3 DADAS to Audio Subsystem (Optional)—Directory One Call Control to Audio Response Unit system interface specifications are available through Northern Telecom as a licensed access protocol—Northern Telecom Document 355-004424 and Gateway/Interactive Voice subsystem Protocol Specification.
- 10.6.5 Rates for DADAS are as set forth in this Attachment.
- 10.7 **Automatic Location Identification/Data Management System (ALI/DMS)**
- 10.7.1 The ALI/DMS Database contains end user information (including name, address, telephone information, and sometimes special information from the local service provider or end user) used to determine to which Public Safety Answering Point (PSAP) to route the call. The ALI/DMS database is used to provide more routing flexibility for E911 calls than Basic 911. BellSouth shall provide the Emergency Services Database in accordance with the following:
- 10.7.2 Technical Requirements
- 10.7.2.1 BellSouth shall offer Level 3 a data link to the ALI/DMS database or permit Level 3 to provide its own data link to the ALI/DMS database. BellSouth shall provide error reports from the ALI/DMS database to Level 3 immediately after Level 3 inputs information into the ALI/DMS database. Alternately, Level 3 may utilize BellSouth,

to enter end user information into the data base on a demand basis, and validate end user information on a demand basis.

10.7.2.2 The ALI/DMS database shall contain the following end user information:

10.7.2.2.1 Name;

10.7.2.2.2 Address;

10.7.2.2.3 Telephone number; and

10.7.2.2.4 Other information as appropriate (e.g., whether a end user is blind or deaf or has another disability).

10.7.2.3 When BellSouth is responsible for administering the ALI/DMS database in its entirety, ported number NXXs entries for the ported numbers should be maintained unless Level 3 requests otherwise and shall be updated if Level 3 requests, provided Level 3 supplies BellSouth with the updates.

10.7.2.4 When Remote Call Forwarding (RCF) is used to provide number portability to the local end user and a remark or other appropriate field information is available in the database, the shadow or “forwarded-to” number and an indication that the number is ported shall be added to the customer record.

10.7.2.5 If BellSouth is responsible for configuring PSAP features (for cases when the PSAP or BellSouth supports an ISDN interface) it shall ensure that CLASS Automatic Recall (Call Return) is not used to call back to the ported number. Although BellSouth currently does not have ISDN interface, BellSouth agrees to comply with this requirement once ISDN interfaces are in place.

10.7.3 Interface Requirements

The interface between the E911 Switch or Tandem and the ALI/DMS database for Level 3 end users shall meet industry standards.

10.8 Rates

The prices that Level 3 shall pay to BellSouth for Services rendered pursuant to Section 10 are set forth in Exhibit C to this Attachment.

11. Calling Name (CNAM) Database Service

- 11.1 All of the negotiated rates, terms and conditions set forth in this Section pertain to the provision of CNAM.
- 11.2 The Agreement for Calling Name (CNAM) with standard pricing is included as Exhibit B to this Attachment. Level 3 must provide to its account manager a written request with a requested activation date to activate this service. If Level 3 is interested in requesting CNAM with volume and term pricing, Level 3 must contact its account manager to request a separate CNAM volume and term Agreement.
- 11.3 SCPs/Databases shall be equal to or better than all of the requirements for SCPs/Databases set forth in the applicable industry standard technical references.

11.4 Service Creation Environment and Service Management System (SCE/SMS) Advanced Intelligent Network (AIN) Access

- 11.4.1 BellSouth's Service Creation Environment and Service Management System (SCE/SMS) Advanced Intelligent Network (AIN) Access shall provide Level 3 the capability that will allow Level 3 and other third parties to create service applications in a BellSouth Service Creation Environment and deploy those applications in a BellSouth SMS to a BellSouth SCP. The third party service applications interact with AIN triggers provisioned on a BellSouth SSP.
- 11.4.2 BellSouth's SCE/SMS AIN Access shall provide access to SCE hardware, software, testing and technical support (e.g., help desk, system administrator) resources available to Level 3. Scheduling procedures shall provide Level 3 equivalent priority to these resources.
- 11.4.2 BellSouth SCP shall partition and protect Level 3 service logic and data from unauthorized access, execution or other types of compromise.
- 11.4.3 When Level 3 selects SCE/SMS AIN Access, BellSouth shall provide training, documentation, and technical support to enable Level 3 to use BellSouth's SCE/SMS AIN Access to create and administer applications. Training, documentation, and technical support will address use of SCE and SMS access and administrative functions, but will not include support for the creation of a specific service application.
- 11.4.4 When Level 3 selects SCE/SMS AIN Access, BellSouth shall provide for a secure, controlled access environment in association with its internal use of AIN components. Level 3 access will be provided via remote data connection (e.g., dial-in, ISDN).

11.4.5 When Level 3 selects SCE/SMS AIN Access, BellSouth shall allow Level 3 to download data forms and/or tables to BellSouth SCP via BellSouth SMS without intervention from BellSouth (e.g., service customization and end user subscription).

11.5 Rates

The prices that Level 3 shall pay to BellSouth for Network Elements and Other Services are set forth in Exhibit C to this Attachment.

12. Basic 911 and E911

12.1 All of the negotiated terms and conditions set forth in this Section pertain to the provision of Basic 911 and E911.

12.2 If Level 3 orders network elements and other services, then Level 3 is also responsible for providing E911 to its end users. BellSouth agrees to offer access to the 911/E911 network pursuant to the following terms and conditions set forth in this Attachment.

12.3 Definition

12.4 Basic 911 and E911 is an additional requirement that provides a caller access to the applicable emergency service bureau by dialing a 3-digit universal telephone number (911).

12.5 Requirements

12.5.1 Basic 911 Service Provisioning. For Basic 911 service, BellSouth will provide to Level 3 a list consisting of each municipality that subscribes to Basic 911 service. The list will also provide, if known, the E911 conversion date for each municipality and, for network routing purposes, a ten-digit directory number representing the appropriate emergency answering position for each municipality subscribing to 911. Level 3 will be required to arrange to accept 911 calls from its end users in municipalities that subscribe to Basic 911 service and translate the 911 call to the appropriate 10-digit directory number as stated on the list provided by BellSouth. Level 3 will be required to route that call to BellSouth at the appropriate tandem or end office. When a municipality converts to E911 service, Level 3 will be required to discontinue the Basic 911 procedures and being using E911 procedures.

12.5.2 E911 Service Provisioning. For E911 service, Level 3 will be required to install a minimum of two dedicated trunks originating from the Level 3 serving wire center and terminating to the appropriate E911 tandem. The dedicated trunks shall be, at a minimum, DS-0 level trunks configured either as a 2-wire analog interface or as part of a digital (1.544 Mb/s) interface. Either configuration shall use CAMA-type signaling with multifrequency (“MF”) pulsing that will deliver automatic number identification (“ANI”) with the voice portion of the call. If the user interface is digital, MF pulses, as well as other AC signals, shall be encoded per the u-255 Law convention. Level 3 will be required to provide BellSouth daily updates to the E911 database. Level 3 will be required to forward 911 calls to the appropriate E911 tandem, along with ANI, based upon the current E911 end office to tandem homing arrangement as provided by BellSouth. If the E911 tandem trunks are not available, Level 3 will be required to route the call to a designated 7-digit local number residing in the appropriate Public Service Answering Point (“PSAP”). This call will be transported over BellSouth’s

- interoffice network and will not carry the ANI of the calling party. Level 3 shall be responsible for providing BellSouth with complete and accurate data for submission to the 911/E911 database for the purpose of providing 911/E911 to its end users.
- 12.5.3 Rates. Charges for 911/E911 service are borne by the municipality purchasing the service. BellSouth will impose no charge on Level 3 beyond applicable charges for BellSouth trunking arrangements.
- 12.5.4 Basic 911 and E911 functions provided to Level 3 shall be at least at parity with the support and services that BellSouth provides to its end users for such similar functionality.
- 12.5.5 Detailed Practices and Procedures. The detailed practices and procedures contained in the E911 Local Exchange Carrier Guide For Facility-Based Providers as amended from time to time during the term of this Agreement will determine the appropriate practices and procedures for BellSouth and Level 3 to follow in providing 911/E911 services.

13. True-Up

This section applies only to Tennessee and other rates that are interim or expressly subject to true-up under this attachment.

- 13.1 The interim prices for Network Elements and Other Services and Local Interconnection shall be subject to true-up according to the following procedures:
- 13.2 The interim prices shall be trued-up, either up or down, based on final prices determined either by further agreement between the Parties, or by a final order (including any appeals) of the Commission which final order meets the criteria of 13.4 below. The Parties shall implement the true-up by comparing the actual volumes and demand for each item, together with interim prices for each item, with the final prices determined for each item. Each Party shall keep its own records upon which the true-up can be based, and any final payment from one Party to the other shall be in an amount agreed upon by the Parties based on such records. In the event of any disagreement as between the records or the Parties regarding the amount of such true-up, the Parties agree that the body having jurisdiction over the matter shall be called upon to resolve such differences, or the Parties may mutually agree to submit the matter to the Dispute Resolution process in accordance with the provisions of Section 16 of the General Terms and Conditions and Attachment 1 of the Agreement.
- 13.3 The Parties may continue to negotiate toward final prices, but in the event that no such Agreement is reached within nine (9) months, either Party may petition the

Commission to resolve such disputes and to determine final prices for each item. Alternatively, upon mutual agreement, the Parties may submit the matter to the Dispute Resolution Process set forth in Section 16 of the General Terms and Conditions and Attachment 1 of the Agreement, so long as they file the resulting Agreement with the Commission as a “negotiated Agreement” under Section 252(e) of the Act.

- 13.4 A final order of the Commission that forms the basis of a true-up shall be the final order as to prices based on appropriate cost studies, or potentially may be a final order in any other Commission proceeding which meets the following criteria:
- (a) BellSouth and Level 3 are entitled to be a full Party to the proceeding;
 - (b) It shall apply the provisions of the federal Telecommunications Act of 1996, including but not limited to Section 252(d)(1) (which contains pricing standards) and all then-effective implementing rules and regulations; and,
 - (c) (in the case of loops or ports only) It shall include as an issue the geographic deaveraging of network element and other services prices, which deaveraged prices, if any are required by said final order, shall form the basis of any true-up.

EXHIBIT A

**LINE INFORMATION DATA BASE (LIDB)
STORAGE AGREEMENT**

I. SCOPE

- A. This Agreement sets forth the terms and conditions pursuant to which BellSouth agrees to store in its LIDB certain information at the request of Level 3 and pursuant to which BellSouth, its LIDB customers and Level 3 shall have access to such information. Level 3 understands that BellSouth provides access to information in its LIDB to various telecommunications service providers pursuant to applicable tariffs and agrees that information stored at the request of Level 3, pursuant to this Agreement, shall be available to those telecommunications service providers. The terms and conditions contained in the attached Addendum(s) are hereby made a part of this Agreement as if fully incorporated herein.
- B. LIDB is accessed for the following purposes:
1. Billed Number Screening
 2. Calling Card Validation
 3. Fraud Control
- C. BellSouth will provide seven days per week, 24-hours per day, fraud monitoring on Calling Cards, bill-to-third and collect calls made to numbers in BellSouth's LIDB, provided that such information is included in the LIDB query. BellSouth will establish fraud alert thresholds and will notify Level 3 of fraud alerts so that Level 3 may take action it deems appropriate. Level 3 understands and agrees BellSouth will administer all data stored in the LIDB, including the data provided by Level 3 pursuant to this Agreement, in the same manner as BellSouth's data for BellSouth's end user customers. BellSouth shall not be responsible to Level 3 for any lost revenue which may result from BellSouth's administration of the LIDB pursuant to its established practices and procedures as they exist and as they may be changed by BellSouth in its sole discretion from time to time.

Level 3 understands that BellSouth currently has in effect numerous billing and collection agreements with various interexchange carriers and billing clearing houses. Level 3 further understands that these billing and collection customers of BellSouth query BellSouth's LIDB to determine whether to accept various billing options from end users. Additionally, Level 3 understands that presently BellSouth has no method to differentiate between BellSouth's own billing and line data in the LIDB and such data which it includes in the LIDB on Level 3's behalf pursuant to this Agreement. Therefore, until such time as BellSouth can and does implement in its LIDB and its supporting systems the means to differentiate Level 3's data from BellSouth's data and

the Parties to this Agreement execute appropriate amendments hereto, the following terms and conditions shall apply:

- (a) Level 3 agrees that it will accept responsibility for telecommunications services billed by BellSouth for its billing and collection customers for Level 3's end user accounts which are resident in LIDB pursuant to this Agreement. Level 3 authorizes BellSouth to place such charges on Level 3's bill from BellSouth and agrees that it shall pay all such charges. Charges for which Level 3 hereby takes responsibility include, but are not limited to, collect and third number calls.
- (b) Charges for such services shall appear on a separate BellSouth bill page identified with the name of the entity for which BellSouth is billing the charge.
- (c) Level 3 shall have the responsibility to render a billing statement to its end users for these charges, but Level 3's obligation to pay BellSouth for the charges billed shall be independent of whether Level 3 is able or not to collect from Level 3's end users.
- (d) BellSouth shall not become involved in any disputes between Level 3 and the entities for which BellSouth performs billing and collection. BellSouth will not issue adjustments for charges billed on behalf of an entity to Level 3. It shall be the responsibility of Level 3 and the other entity to negotiate and arrange for any appropriate adjustments.

II. TERM

This Agreement will be effective as of _____, and will continue in effect for one year, and thereafter may be continued until terminated by either Party upon thirty (30) days written notice to the other Party.

III. FEES FOR SERVICE AND TAXES

- A. Level 3 will not be charged a fee for storage services provided by BellSouth to Level 3, as described in Section I of this Agreement.
- B. Sales, use and all other taxes (excluding taxes on BellSouth's income) determined by BellSouth or any taxing authority to be due to any federal, state or local taxing jurisdiction with respect to the provision of the service set forth herein will be paid by Level 3. Level 3 shall have the right to have BellSouth contest with the imposing jurisdiction, at Level 3's expense, any such taxes that Level 3 deems are improperly levied.

IV. INDEMNIFICATION

To the extent not prohibited by law, each Party will indemnify the other and hold the other harmless against any loss, cost, claim, injury, or liability relating to or arising out of negligence or willful misconduct by the indemnifying Party or its agents or contractors in connection with the indemnifying Party's provision of services, provided, however, that any indemnity for any loss, cost, claim, injury or liability arising out of or relating to errors or omissions in the provision of services under this Agreement shall be limited as otherwise specified in this Agreement. The indemnifying Party under this Section agrees to defend any suit brought against the other Party for any such loss, cost, claim, injury or liability. The indemnified Party agrees to notify the other Party promptly, in writing, of any written claims, lawsuits, or demands for which the other Party is responsible under this Section and to cooperate in every reasonable way to facilitate defense or settlement of claims. The indemnifying Party shall not be liable under this Section for settlement by the indemnified Party of any claim, lawsuit, or demand unless the defense of the claim, lawsuit, or demand has been tendered to it in writing and the indemnifying Party has unreasonably failed to assume such defense.

V. LIMITATION OF LIABILITY

Neither Party shall be liable to the other Party for any lost profits or revenues or for any indirect, incidental or consequential damages incurred by the other Party arising from this Agreement or the services performed or not performed hereunder, regardless of the cause of such loss or damage.

VI. MISCELLANEOUS

- A. It is understood and agreed to by the Parties that BellSouth may provide similar services to other companies.
- B. All terms, conditions and operations under this Agreement shall be performed in accordance with, and subject to, all applicable local, state or federal legal and regulatory tariffs, rulings, and other requirements of the federal courts, the U. S. Department of Justice and state and federal regulatory agencies. Nothing in this Agreement shall be construed to cause either Party to violate any such legal or regulatory requirement and either Party's obligation to perform shall be subject to all such requirements.
- C. Level 3 agrees to submit to BellSouth all advertising, sales promotion, press releases, and other publicity matters relating to this Agreement wherein BellSouth's corporate or trade names, logos, trademarks or service marks or those of BellSouth's affiliated companies are mentioned or language from which the connection of said names or trademarks therewith may be inferred or implied; and Level 3 further agrees not to

- publish or use advertising, sales promotions, press releases, or publicity matters without BellSouth's prior written approval.
- D. This Agreement constitutes the entire Agreement between Level 3 and BellSouth which supersedes all prior Agreements or contracts, oral or written representations, statements, negotiations, understandings, proposals and undertakings with respect to the subject matter hereof.
- E. Except as expressly provided in this Agreement, if any part of this Agreement is held or construed to be invalid or unenforceable, the validity of any other Section of this Agreement shall remain in full force and effect to the extent permissible or appropriate in furtherance of the intent of this Agreement.
- F. Neither Party shall be held liable for any delay or failure in performance of any part of this Agreement for any cause beyond its control and without its fault or negligence, such as acts of God, acts of civil or military authority, government regulations, embargoes, epidemics, war, terrorist acts, riots, insurrections, fires, explosions, earthquakes, nuclear accidents, floods, strikes, power blackouts, volcanic action, other major environmental disturbances, unusually severe weather conditions, inability to secure products or services of other persons or transportation facilities, or acts or omissions of transportation common carriers.
- G. This Agreement shall be deemed to be a contract made under the laws of the State of Georgia, and the construction, interpretation and performance of this Agreement and all transactions hereunder shall be governed by the domestic law of such State.

**FACILITIES BASED ADDENDUM
TO LINE INFORMATION DATA BASE (LIDB)
STORAGE AGREEMENT**

This is a Facilities Based Addendum to the Line Information Data Base Storage Agreement dated _____, between BellSouth Telecommunications, Inc. (“BellSouth”), and _____ (“Level 3”), effective the ____ day of _____, ____.

I. GENERAL

This Addendum sets forth the terms and conditions for Level 3’s provision of billing number information to BellSouth for inclusion in BellSouth’s LIDB. BellSouth will store in its LIDB the billing number information provided by Level 3, and BellSouth will provide responses to on-line, call-by-call queries to this information for purposes specified in Section I.B. of the Agreement.

II. DEFINITIONS

- A. Billing number - a number that Level 3 creates for the purpose of identifying an account liable for charges. This number may be a line or a special billing number.
- B. Line number - a ten digit number that identifies a telephone line administered by Level 3.
- C. Special billing number - a ten digit number that identifies a billing account established by Level 3.
- D. Calling Card number - a billing number plus PIN number.
- E. PIN number - a four digit security code assigned by Level 3 which is added to a billing number to compose a fourteen digit calling card number.
- F. Toll billing exception indicator - associated with a billing number to indicate that it is considered invalid for billing of collect calls or third number calls or both, by Level 3.
- G. Billed Number Screening - refers to the activity of determining whether a toll billing exception indicator is present for a particular billing number.

- H. Calling Card Validation - refers to the activity of determining whether a particular calling card number exists as stated or otherwise provided by a caller.
- I. Billing number information - information about billing number, Calling Card number and toll billing exception indicator provided to BellSouth by Level 3.

III. RESPONSIBILITIES OF PARTIES

- A. Level 3 will provide its billing number information to BellSouth's LIDB each business day by a method that has been mutually agreed upon by both Parties.
- B. BellSouth will store in its LIDB the billing number information provided by Level 3. Under normal operating conditions, BellSouth shall include Level 3's billing number information in its LIDB no later than two business days following BellSouth's receipt of such billing number information, provided that BellSouth shall not be held responsible for any delay or failure in performance to the extent such delay or failure is caused by circumstances or conditions beyond BellSouth's reasonable control. BellSouth will store in its LIDB an unlimited volume of Level 3's working telephone numbers.
- C. BellSouth will provide responses to on-line, call-by-call queries to the stored information for the specific purposes listed in the next paragraph.
- D. BellSouth is authorized to use the billing number information provided by Level 3 to perform the following functions for authorized users on an on-line basis:
 - 1. Validate a 14 digit Calling Card number where the first 10 digits are a line number or special billing number assigned by Level 3, and where the last four digits (PIN) are a security code assigned by Level 3.
 - 2. Determine whether Level 3 or the subscriber has identified the billing number as one which should not be billed for collect or third number calls, or both.
- E. Level 3 will provide its own billing number information to BellSouth for storage and to be used for Billed Number Screening and Calling Card Validation. Level 3 will arrange and pay for transport of updates to BellSouth.

IV. COMPLIANCE

Unless expressly authorized in writing by Level 3, all billing number information provided pursuant to this Addendum shall be used for no purposes other than those set forth in this Addendum.

EXHIBIT B

CALLING NAME DELIVERY (CNAM) DATABASE SERVICES

1. Definitions

For the purpose of this Attachment, the following terms shall be defined as:

CALLING NAME DELIVERY DATABASE SERVICE (CNAM) - The ability to associate a name with the calling party number, allowing the end user subscriber (to which a call is being terminated) to view the calling party's name before the call is answered. This service also provides Level 3 the opportunity to load and store its subscriber names in the BellSouth CNAM SCPs.

CALLING PARTY NUMBER (CPN) - The number of the calling party that is delivered to the terminating switch using common channel signaling system 7 (CCS7) technology, and that is contained in the Initial Address Message (IAM) portion of the CCS7 call setup.

COMMON CHANNEL SIGNALING SYSTEM 7 (CCS7) - A network signaling technology in which all signaling information between two or more nodes is transmitted over high-speed data links, rather than over voice circuits.

SERVICE CONTROL POINTs (SCPs) - The real-time data base systems that contain the names to be provided in response to queries received from CNAM SSPs.

SERVICE MANAGEMENT SYSTEM (SMS) - The main operations support system of CNAM DATABASE SERVICE. CNAM records are loaded into the SMS, which in turn downloads into the CNAM SCP.

SERVICE SWITCHING POINTs (SSPs) - Features of computerized switches in the telephone network that determine that a terminating line has subscribed to CNAM service, and then communicate with CNAM SCPs in order to provide the name associated with the calling party number.

SUBSYSTEM NUMBER (SSN) - The address used in the Signaling Connection Control Part (SCCP) layer of the SS7 protocol to designate an application at an end signaling point. A SSN for CNAM at the end office designates the CNAM application within the end office. BellSouth uses the CNAM SSN of 232.

2. Attachment

2.1 This Attachment contains the terms and conditions where BellSouth will provide to the Level 3 access to the BellSouth CNAM SCP for query or record storage purposes.

- 2.2 Level 3 shall submit to BellSouth a notice of its intent to access and utilize BellSouth CNAM Database Services pursuant to the terms and conditions of this Attachment. Said notice shall be in writing, no less than 60 days prior to Level 3's access to BellSouth's CNAM Database Services and shall be addressed to Level 3's Account Manager.

3. Physical Connection and Compensation

- 3.1 BellSouth's provision of CNAM Database Services to Level 3 requires interconnection from Level 3 to BellSouth CNAM Service Control Points (SCPs). Such interconnections shall be established pursuant to Attachment 3 of this Agreement. The appropriate charge for access to and use of the BellSouth CNAM Database service shall be as set forth in this Attachment.
- 3.2 In order to formulate a CNAM query to be sent to the BellSouth CNAM SCP, Level 3 shall provide its own CNAM SSP. Level 3's CNAM SSPs must be compliant with TR-NWT-001188, "CLASS Calling Name Delivery Generic Requirements".
- 3.3 If Level 3 elects to access the BellSouth CNAM SCP via a third party CCS7 transport provider, the third party CCS7 provider shall interconnect with the BellSouth CCS7 network according to BellSouth's Common Channel Signaling Interconnection Guidelines and Telcordia (formerly BellCore)'s CCS Network Interface Specification document, TR-TSV-000905. In addition, the third party provider shall establish CCS7 interconnection at the BellSouth Local Signal Transfer Points (LSTPs) serving the BellSouth CNAM SCPs that Level 3 desires to query.
- 3.4 **Out-Of-Region Customers**
If the customer queries the BellSouth CNAM SCP via a third party national SS7 transport provider, the third party SS7 provider shall interconnect with the BellSouth CCS7 network according to BellSouth's Common Channel Signaling Interconnection Guidelines and Telcordia's (formerly BellCore's) CCS Network Interface Specification document, TR-TSV-000905. In addition, the third party provider shall establish SS7 interconnection at one or more of the BellSouth Gateway Signal Transfer Points (STPs). The payment of all costs associated with the transport of SS7 signals via a third party will be established by mutual agreement of the Parties in writing and shall, by this reference become an integral part of this Agreement.

4. CNAM Record Initial Load and Updates

- 4.1 The mechanism to be used by Level 3 for initial CNAM record load and/or updates shall be determined by mutual agreement. The initial load and all updates shall be provided by Level 3 in the BellSouth specified format and shall contain records for

every working telephone number that can originate phone calls. It is the responsibility of Level 3 to provide accurate information to BellSouth on a current basis.

- 4.2 Updates to the SMS shall occur no less than once a week, reflect service order activity affecting either name or telephone number, and involve only record additions, deletions or changes.
- 4.3 Level 3 CNAM records provided for storage in the BellSouth CNAM SCP shall be available, on a SCP query basis only, to all Parties querying the BellSouth CNAM SCP. Further, CNAM service shall be provided by each Party consistent with state and/or federal regulation.

BELLSOUTH/LEVEL 3 RATES
NETWORK ELEMENTS
AND OTHER SERVICES

DESCRIPTION	USOC	RATES BY STATE									
		AL	FL	GA	KY	LA	MS	NC	SC	TN	
NIDs											
NID to NID Cross Connect, 2-Wire or 4-Wire, NRC	UNDC2	NA	\$6.15	NA	NA	NA	NA	NA	NA	NA	NA
NID to NID Cross Connect, 2-Wire or 4-Wire, NRC	UNDC4	NA	\$6.15	NA	NA	NA	NA	NA	NA	NA	NA
NID, 1-2 lines	UND12	NA	NA	NA	NA	NA	NA	NA	NA	NA	NA
NRC - 1st	UND12	TBN	TBD	TBD	TBD	TBD	TBD	TBD	TBD	TBD	TBN
NRC - Add'l	UND12	TBN	TBD	TBD	TBD	TBD	TBD	TBD	TBD	TBD	TBN
NRC - Disconnect Charge - 1st	UND12	TBN	TBD	TBD	TBD	TBD	TBD	TBD	TBD	TBD	TBN
NRC - Disconnect Charge - Add'l	UND12	TBN	TBD	TBD	TBD	TBD	TBD	TBD	TBD	TBD	TBN
NRC - Incremental Charge - Manual Service Order - 1st	SOMAN	TBN	TBD	TBD	TBD	TBD	TBD	TBD	TBD	TBD	TBN
NRC - Incremental Charge - Manual Service Order - Add'l	SOMAN	TBN	TBD	TBD	TBD	TBD	TBD	TBD	TBD	TBD	TBN
NRC - Incremental Charge - Manual Service Order - Disconnect	SOMAN	TBN	TBD	TBD	TBD	TBD	TBD	TBD	TBD	TBD	TBN
NID, 1-6 lines	UND16	NA	NA	NA	TBD	NA	NA	NA	NA	NA	NA
NRC - 1st	UND16	TBN	TBN	TBN	TBN	TBN	TBN	TBN	TBN	TBN	TBN
NRC - Add'l	UND16	TBN	TBN	TBN	TBN	TBN	TBN	TBN	TBN	TBN	TBN
NRC - Disconnect Charge - 1st	UND16	TBN	TBN	TBN	TBN	TBN	TBN	TBN	TBN	TBN	TBN
NRC - Disconnect Charge - Add'l	UND16	TBN	TBN	TBN	TBN	TBN	TBN	TBN	TBN	TBN	TBN
NRC - Incremental Charge - Manual Service Order - 1st	SOMAN	TBN	TBN	TBN	TBN	TBN	TBN	TBN	TBN	TBN	TBN
NRC - Incremental Charge - Manual Service Order - Add'l	SOMAN	TBN	TBN	TBN	TBN	TBN	TBN	TBN	TBN	TBN	TBN
NRC - Incremental Charge - Manual Service Order - Disconnect	SOMAN	TBN	TBN	TBN	TBN	TBN	TBN	TBN	TBN	TBN	TBN
Nonrecurring Charge - customer transfer, feature additions, changes (1)		\$5.00	NA	NA	NA	NA	\$5.00	NA	NA	NA	
LOOP, EXCLUDING NID											
2-Wire Analog VG Loop (Standard), per month	TBD	NA	NA	NA	\$18.20	NA	NA	NA	NA	NA	NA
NRC - 1st		NA	NA	NA	\$86.08	NA	NA	NA	NA	NA	NA
NRC - Add'l		NA	NA	NA	\$58.57	NA	NA	NA	NA	NA	NA
2-Wire Analog VG Loop (Customized), per month	TBD	NA	NA	NA	\$21.41	NA	NA	NA	NA	NA	NA
NRC - 1st		NA	NA	NA	\$236.75	NA	NA	NA	NA	NA	NA
NRC - Add'l		NA	NA	NA	\$177.10	NA	NA	NA	NA	NA	NA
4-Wire Analog VG Loop (Standard), per month	TBD	NA	NA	NA	\$26.38	NA	NA	NA	NA	NA	NA
NRC - 1st		NA	NA	NA	\$457.14	NA	NA	NA	NA	NA	NA
NRC - Add'l		NA	NA	NA	\$348.83	NA	NA	NA	NA	NA	NA
2-Wire ISDN Digital Grade Loop (Standard), per month	TBD	NA	NA	NA	\$29.65	NA	NA	NA	NA	NA	NA
NRC - 1st		NA	NA	NA	\$541.28	NA	NA	NA	NA	NA	NA
NRC - Add'l		NA	NA	NA	\$431.61	NA	NA	NA	NA	NA	NA
2-Wire ADSL Loop (Standard), per month	TBD	NA	NA	NA	\$10.63	NA	NA	NA	NA	NA	NA
NRC - 1st		NA	NA	NA	\$713.50	NA	NA	NA	NA	NA	NA
NRC - Add'l		NA	NA	NA	\$609.44	NA	NA	NA	NA	NA	NA
2-Wire HDSL Loop (Standard), per month	TBD	NA	NA	NA	\$7.40	NA	NA	NA	NA	NA	NA
NRC - 1st		NA	NA	NA	\$713.50	NA	NA	NA	NA	NA	NA
NRC - Add'l		NA	NA	NA	\$609.44	NA	NA	NA	NA	NA	NA
4-Wire HDSL Loop (Standard), per month	TBD	NA	NA	NA	\$9.70	NA	NA	NA	NA	NA	NA
NRC - 1st		NA	NA	NA	\$748.93	NA	NA	NA	NA	NA	NA
NRC - Add'l		NA	NA	NA	\$646.17	NA	NA	NA	NA	NA	NA
LOOP, INCLUDING NID											
2-Wire Analog VG Loop-SL1, per month											
RC - Statewide, per month	UEAL2	NA	NA	NA	NA	NA	NA	\$15.88	NA	NA	
RC - Zone 1, per month (Note 2)	TBD	\$15.24	\$13.75	\$14.21	\$14.79	\$14.96	\$15.58	TBD	\$18.48	\$15.92	
RC - Zone 2, per month (Note 2)	TBD	\$24.75	\$20.13	\$16.41	\$27.68	\$25.69	\$20.65	TBD	\$27.87	\$20.79	
RC - Zone 3, per month (Note 2)	TBD	\$44.85	\$44.40	\$26.08	\$47.78	\$52.47	\$29.51	TBD	\$36.91	\$27.18	
RC - Zone 4, per month (Note 2)	TBD	NA	NA	NA	NA	NA	\$38.94	NA	NA	NA	
NRC - 1st	UEAL2	\$59.03	\$80.00	\$42.54	NA	\$40.69	\$59.25	\$57.99	\$70.44	\$78.93	
NRC - Add'l	UEAL2	\$43.14	\$55.00	\$31.33	NA	\$29.96	\$43.67	\$42.37	\$44.05	\$50.98	
NRC - Disconnect Charge - 1st	UEAL2	\$15.21	NA	NA	NA	\$16.48	\$16.35	NA	NA	NA	

**BELLSOUTH/LEVEL 3 RATES
NETWORK ELEMENTS
AND OTHER SERVICES**

	NRC - Disconnect Charge - Add'l	UEAL2	\$3.22	NA	NA	NA	\$3.36	\$4.06	NA	NA	NA	
	NRC - Incremental Charge - Manual Service Order - 1st	SOMAN	\$27.37	NA	\$18.94	NA	\$18.14	\$25.52	\$26.94	\$44.22	NA	
	NRC - Incremental Charge - Manual Service Order - Add'l	SOMAN	\$12.97	NA	\$8.42	NA	\$8.06	\$11.34	\$12.76	\$13.55	NA	
	NRC - Incremental Charge - Manual Service Order - Disconnect	SOMAN	\$17.77	NA	NA	NA	\$11.41	\$16.06	NA	NA	NA	
	2-Wire Analog VG Loop-SL2 w/loop or ground start signaling, per month											
	RC - Statewide, per month	UEAL2	NA	NA	NA	NA	NA	NA	\$19.50	NA	NA	
	RC - Zone 1, per month (Note 2)	TBD	\$17.95	\$13.75	\$16.84	\$17.27	\$17.65	\$18.35	TBD	\$21.57	\$15.92	
	RC - Zone 2, per month (Note 2)	TBD	\$29.16	\$20.13	\$19.45	\$32.32	\$30.32	\$24.33	TBD	\$32.53	\$20.79	
	RC - Zone 3, per month (Note 2)	TBD	\$52.84	\$44.40	\$30.92	\$55.78	\$61.93	\$34.77	TBD	\$43.08	\$27.18	
	RC - Zone 4, per month (Note 2)	TBD	NA	NA	NA	NA	NA	\$45.88	NA	NA	NA	
	NRC - 1st	UEAL2	\$145.46	\$140.00	\$104.17	NA	\$99.69	\$144.01	\$142.97	\$178.12	\$192.97	
	NRC - Add'l	UEAL2	\$108.40	\$42.00	\$78.10	NA	\$74.73	\$107.70	\$106.56	\$128.80	\$140.72	
	NRC - Disconnect Charge - 1st	UEAL2	\$40.31	NA	NA	NA	\$28.73	\$40.98	NA	NA	NA	
	NRC - Disconnect Charge - Add'l	UEAL2	\$26.01	NA	NA	NA	\$18.87	\$26.95	NA	NA	NA	
	NRC - Incremental Charge - Manual Service Order - 1st	SOMAN	\$27.37	NA	\$18.94	NA	\$18.14	\$25.52	\$26.94	\$44.42	NA	
	NRC - Incremental Charge - Manual Service Order - Add'l	SOMAN	\$12.97	NA	\$8.42	NA	\$8.06	\$11.34	\$12.76	\$13.55	NA	
	NRC - Incremental Charge - Manual Service Order - Disconnect	SOMAN	\$17.77	NA	NA	NA	\$11.41	\$26.95	NA	NA	NA	
	NRC - Incremental Charge - Order Coordination - Time Specific (per LSR)	OCOSL	\$45.99	\$55.00	\$34.22	NA	\$32.77	\$45.27	\$45.34	\$45.43	\$55.00	
	2-Wire Analog VG Loop-SL2 w/ reverse battery signaling, per month											
	RC - Statewide, per month	UEAR2	NA	NA	NA	NA	NA	NA	\$19.50	NA	NA	
	RC - Zone 1, per month (Note 2)	TBD	\$17.95	\$13.75	\$16.84	\$17.27	\$17.65	\$18.35	TBD	\$21.57	\$15.92	
	RC - Zone 2, per month (Note 2)	TBD	\$29.16	\$20.13	\$19.45	\$32.32	\$30.32	\$24.33	TBD	\$32.53	\$20.79	
	RC - Zone 3, per month (Note 2)	TBD	\$52.84	\$44.40	\$30.92	\$55.78	\$61.93	\$34.77	TBD	\$43.08	\$27.18	
	RC - Zone 4, per month (Note 2)	TBD	NA	NA	NA	NA	NA	\$45.88	NA	NA	NA	
	NRC - 1st	UEAR2	\$145.46	\$140.00	\$104.17	NA	\$99.69	\$144.01	\$142.97	\$178.12	\$192.97	
	NRC - Add'l	UEAR2	\$108.40	\$42.00	\$78.10	NA	\$74.73	\$107.70	\$106.56	\$128.80	\$140.72	
	NRC - Disconnect Charge - 1st	UEAR2	\$40.31	NA	NA	NA	\$28.73	\$40.98	NA	NA	NA	
	NRC - Disconnect Charge - Add'l	UEAR2	\$26.01	NA	NA	NA	\$18.87	\$26.95	NA	NA	NA	
	NRC - Incremental Charge - Manual Service Order - 1st	SOMAN	\$27.37	NA	\$18.94	NA	\$18.14	\$25.52	\$26.94	\$44.42	NA	
	NRC - Incremental Charge - Manual Service Order - Add'l	SOMAN	\$12.97	NA	\$8.42	NA	\$8.06	\$11.34	\$12.76	\$13.55	NA	
	NRC - Incremental Charge - Manual Service Order - Disconnect	SOMAN	\$17.77	NA	NA	NA	\$11.41	\$26.95	NA	NA	NA	
	NRC - Incremental Charge - Order Coordination - Time Specific (per LSR)	OCOSL	\$45.99	\$55.00	\$34.22	NA	\$32.77	\$45.27	\$45.34	\$45.43	\$55.00	
	4-Wire Analog VG Loop, per month											
	RC - Statewide, per month	UEAL4	NA	NA	NA	NA	NA	NA	\$27.49	NA	NA	
	RC - Zone 1, per month (Note 2)	TBD	\$24.01	\$24.26	\$22.26	NA	\$24.36	\$22.38	TBD	\$29.47	\$15.92	
	RC - Zone 2, per month (Note 2)	TBD	\$39.00	\$35.51	\$25.70	NA	\$41.85	\$29.67	TBD	\$44.44	\$20.79	
	RC - Zone 3, per month (Note 2)	TBD	\$70.67	\$78.35	\$40.85	NA	\$85.47	\$42.40	TBD	\$58.85	\$27.18	
	RC - Zone 4, per month (Note 2)	TBD	NA	NA	NA	NA	NA	\$55.96	NA	NA	NA	
	NRC - 1st	UEAL4	\$293.70	\$141.00	\$206.95	NA	\$198.10	\$289.06	\$288.47	\$383.39	\$58.50	
	NRC - Add'l	UEAL4	\$241.76	\$43.00	\$170.57	NA	\$163.26	\$238.19	\$237.45	\$286.77	\$31.00	
	NRC - Disconnect Charge - 1st	UEAL4	\$108.96	NA	NA	NA	\$74.27	\$108.14	NA	NA	NA	
	NRC - Disconnect Charge - Add'l	UEAL4	\$57.01	NA	NA	NA	\$39.44	\$57.28	NA	NA	NA	
	NRC - Incremental Charge - Manual Service Order - 1st	SOMAN	\$27.37	NA	\$18.94	NA	\$18.14	\$25.52	\$26.94	\$44.06	NA	
	NRC - Incremental Charge - Manual Service Order - Add'l	SOMAN	\$12.97	NA	\$8.42	NA	\$8.06	\$11.34	\$12.76	\$13.55	NA	
	NRC - Incremental Charge - Manual Service Order - Disconnect	SOMAN	\$17.77	NA	NA	NA	\$11.41	\$16.06	NA	NA	NA	
	NRC - Incremental Charge - Order Coordination - Time Specific (per LSR)	OCOSL	\$45.99	\$55.00	\$34.22	NA	\$32.77	\$45.27	\$45.34	\$45.43	\$55.00	
	2-Wire ISDN Digital Grade Loop, per month											
	RC - Statewide, per month	U1L2X	NA	NA	NA	NA	NA	NA	\$24.98	NA	NA	
	RC - Zone 1, per month (Note 2)	TBD	\$23.23	\$32.34	\$21.89	\$23.66	\$21.15	\$21.86	TBD	\$26.68	\$15.92	
	RC - Zone 2, per month (Note 2)	TBD	\$37.74	\$47.35	\$25.27	\$44.28	\$36.22	\$28.97	TBD	\$40.24	\$20.79	
	RC - Zone 3, per month (Note 2)	TBD	\$68.38	\$104.47	\$40.17	\$76.42	\$74.19	\$41.40	TBD	\$53.29	\$27.18	
	RC - Zone 4, per month (Note 2)	TBD	NA	NA	NA	NA	NA	\$54.64	NA	NA	NA	
	NRC - 1st	U1L2X	\$331.85	\$306.00	\$233.38	NA	\$223.27	\$326.38	\$325.91	\$423.04	\$58.50	
	NRC - Add'l	U1L2X	\$255.87	\$283.00	\$180.35	NA	\$172.63	\$252.00	\$251.31	\$301.75	\$31.00	
	NRC - Disconnect Charge - 1st	U1L2X	\$108.95	NA	NA	NA	\$74.27	\$108.14	NA	NA	NA	
	NRC - Disconnect Charge - Add'l	U1L2X	\$57.01	NA	NA	NA	\$39.44	\$57.27	NA	NA	NA	

BELLSOUTH/LEVEL 3 RATES
NETWORK ELEMENTS
AND OTHER SERVICES

	NRC - Incremental Charge - Manual Service Order - 1st	SOMAN	\$27.37	NA	\$18.94	NA	\$18.14	\$25.52	\$26.94	\$44.42	NA	
	NRC - Incremental Charge - Manual Service Order - Add'l	SOMAN	\$12.97	NA	\$8.42	NA	\$8.06	\$11.34	\$12.76	\$13.55	NA	
	NRC - Incremental Charge - Manual Service Order - Disconnect	SOMAN	\$17.77	NA	NA	NA	\$11.41	\$16.06	NA	NA	NA	
	NRC - Incremental Charge - Order Coordination - Time Specific (per LSR)	OCOSL	\$45.99	\$55.00	\$34.22	\$55.00	\$32.77	\$45.27	\$45.34	\$45.43	\$55.00	
	2-Wire Universal Digital Carrier (UDC), statewide, per month	UDC	TBN	TBN	TBN	TBN	TBN	TBN	TBN	TBN	TBN	
	Zone 1, per month	UDC	TBN	TBN	TBN	TBN	TBN	TBN	TBN	TBN	TBN	
	Zone 2, per month	UDC	TBN	TBN	TBN	TBN	TBN	TBN	TBN	TBN	TBN	
	Zone 3, per month	UDC	TBN	TBN	TBN	TBN	TBN	TBN	TBN	TBN	TBN	
	Zone 4, per month	UDC	NA	NA	NA	NA	NA	TBN	NA	NA	NA	
	NRC - 1st	UDC	TBN	TBN	TBN	TBN	TBN	TBN	TBN	TBN	TBN	
	NRC - Add'l	UDC	TBN	TBN	TBN	TBN	TBN	TBN	TBN	TBN	TBN	
	NRC - Disconnect Charge - 1st	UDC	TBN	TBN	TBN	TBN	TBN	TBN	TBN	TBN	TBN	
	NRC - Disconnect Charge - Add'l	UDC	TBN	TBN	TBN	TBN	TBN	TBN	TBN	TBN	TBN	
	NRC - Incremental Charge - Manual Service Order - 1st	SOMAN	TBN	TBN	TBN	TBN	TBN	TBN	TBN	TBN	TBN	
	NRC - Incremental Charge - Manual Service Order - Add'l	SOMAN	TBN	TBN	TBN	TBN	TBN	TBN	TBN	TBN	TBN	
	NRC - Incremental Charge - Manual Service Order - Disconnect	SOMAN	TBN	TBN	TBN	TBN	TBN	TBN	TBN	TBN	TBN	
	NRC - Incremental Charge - Order Coordination - Time Specific (per LSR)	OCOSL	TBN	TBN	TBN	TBN	TBN	TBN	TBN	TBN	TBN	
	2-Wire Asymmetrical Dig Subscriber Line (ADSL) Compatible Loop, includes manual service inquiry and facility reservation, statewide, per month											
	RC - Statewide, per month	UAL2X	NA	NA	NA	NA	NA	NA	\$14.60	NA	\$18.46	
	RC - Zone 1, per month (Note 2)	TBD	\$12.09	\$12.78	\$11.23	\$8.79	\$11.90	\$10.87	TBD	\$17.10	\$15.93	
	RC - Zone 2, per month (Note 2)	TBD	\$19.64	\$18.72	\$12.97	\$16.46	\$20.43	\$14.40	TBD	\$25.79	\$20.05	
	RC - Zone 3, per month (Note 2)	TBD	\$35.59	\$41.29	\$20.62	\$28.40	\$41.73	\$20.58	TBD	\$34.15	\$28.74	
	RC - Zone 4, per month (Note 2)	TBD	NA	NA	NA	NA	NA	\$27.16	NA	NA	NA	
	NRC - 1st	UAL2X	\$514.21	\$113.85	\$359.73	NA	\$343.13	\$504.82	\$504.90	\$600.61	\$640.79	
	NRC - Add'l	UAL2X	\$464.58	\$99.61	\$325.15	NA	\$310.03	\$456.24	\$456.17	\$507.33	\$541.94	
	NRC - Disconnect Charge - 1st	UAL2X	\$106.65	NA	NA	NA	\$72.54	\$105.86	NA	NA	NA	
	NRC - Disconnect Charge - Add'l	SOMAN	\$56.98	NA	NA	NA	\$39.42	\$57.25	\$26.94	NA	NA	
	NRC - Incremental Charge - Manual Service Order - 1st	SOMAN	\$27.37	NA	\$18.94	NA	\$18.14	\$25.52	\$12.76	\$44.42	NA	
	NRC - Incremental Charge - Manual Service Order - Add'l	SOMAN	\$12.97	NA	\$8.42	NA	\$8.06	\$11.34	NA	\$13.55	NA	
	NRC - Incremental Charge - Manual Service Order - Disconnect	SOMAN	\$17.77	NA	NA	NA	\$11.41	\$16.06	NA	NA	NA	
	NRC - Incremental Charge - Order Coordination - Time Specific (per LSR)	OCOSL	\$45.99	\$55.00	\$34.22	NA	\$32.77	\$45.27	\$45.34	\$45.43	\$55.00	
	2-Wire Asymmetrical Dig Subscriber Line (ADSL) Compatible Loop, without manual service inquiry and facility reservation, statewide, per month	UAL2W	NA	NA	NA	NA	NA	NA	\$14.60	NA	\$18.46	
	Zone 1, per month	UAL2W	\$12.09	\$12.78	\$11.23	\$8.79	\$11.90	\$10.87	TBD	\$17.10	TBD	
	Zone 2, per month	UAL2W	\$19.64	\$18.72	\$12.97	\$16.46	\$20.43	\$14.40	TBD	\$25.79	TBD	
	Zone 3, per month	UAL2W	\$35.59	\$41.29	\$20.62	\$28.40	\$41.73	\$20.58	TBD	\$34.15	TBD	
	Zone 4, per month	UAL2W	NA	NA	NA	NA	NA	\$27.16	NA	NA	NA	
	NRC - 1st	UAL2W	\$375.21	\$113.85	\$220.73	\$574.50	\$204.13	\$365.82	\$365.90	\$461.60	\$501.79	
	NRC - Add'l	UAL2W	\$325.58	\$99.61	\$186.15	\$470.44	\$171.03	\$317.24	\$317.17	\$368.33	\$402.94	
	NRC - Disconnect Charge - 1st	UAL2W	\$106.65	NA	NA	NA	\$72.54	\$105.86	NA	NA	NA	
	NRC - Disconnect Charge - Add'l	UAL2W	\$56.98	NA	NA	NA	\$39.42	\$57.25	\$26.94	NA	NA	
	NRC - Incremental Charge - Manual Service Order - 1st	SOMAN	\$27.37	NA	\$18.94	NA	\$18.14	\$25.52	\$12.76	\$44.42	NA	
	NRC - Incremental Charge - Manual Service Order - Add'l	SOMAN	\$12.97	NA	\$8.42	NA	\$8.06	\$11.34	NA	\$13.55	NA	
	NRC - Incremental Charge - Manual Service Order - Disconnect	SOMAN	\$17.77	NA	NA	NA	\$11.41	\$16.06	NA	NA	NA	
	NRC - Incremental Charge - Order Coordination - Time Specific (per LSR)	OCOSL	\$45.99	\$55.00	\$34.22	\$55.00	\$32.77	\$45.27	\$45.34	\$45.43	\$55.00	
	2-Wire High Bit Rate Dig Subscriber Line (HDSL) Compatible Loop, includes manual service inquiry and facility reservation, statewide, per month											
	RC - Statewide, per month	UHL2X	NA	NA	NA	NA	NA	NA	\$11.98	NA	\$13.46	
	RC - Zone 1, per month (Note 2)	UHL2X	\$9.41	\$9.80	\$7.88	\$6.29	\$8.97	\$8.50	TBD	\$12.21	\$11.62	
	RC - Zone 2, per month (Note 2)	UHL2X	\$15.29	\$14.35	\$9.09	\$11.78	\$15.41	\$11.26	TBD	\$18.41	\$14.62	
	RC - Zone 3, per month (Note 2)	UHL2X	\$27.70	\$31.65	\$14.46	\$20.33	\$31.48	\$16.10	TBD	\$24.39	\$20.96	

**BELLSOUTH/LEVEL 3 RATES
NETWORK ELEMENTS
AND OTHER SERVICES**

	RC - Zone 4, per month (Note 2)	UHL2X	NA	NA	NA	NA	NA	NA	\$21.25	NA	NA	NA
	NRC - 1st	UHL2X	\$514.21	\$113.85	\$359.73	NA	\$343.13	\$504.82	\$504.90	\$600.61	\$640.79	
	NRC - Add'l	UHL2X	\$464.58	\$99.61	\$325.15	NA	\$310.03	\$456.24	\$456.17	\$507.33	\$541.94	
	NRC - Disconnect Charge - 1st	UHL2X	\$106.65	NA	NA	NA	\$72.54	\$105.86	NA	NA	NA	
	NRC - Disconnect Charge - Add'l	UHL2X	\$56.98	NA	NA	NA	\$39.42	\$57.25	NA	NA	NA	
	NRC - Incremental Charge - Manual Service Order - 1st	SOMAN	\$27.37	NA	\$18.94	NA	\$18.14	\$25.52	\$26.94	\$44.42	NA	
	NRC - Incremental Charge - Manual Service Order - Add'l	SOMAN	\$12.97	NA	\$8.42	NA	\$8.06	\$11.34	\$12.76	\$13.55	NA	
	NRC - Incremental Charge - Manual Service Order - Disconnect	SOMAN	\$17.77	NA	NA	NA	\$11.41	\$16.06	NA	NA	NA	
	NRC - Incremental Charge - Order Coordination - Time Specific (per LSR)	OCOSL	\$45.99	\$55.00	\$34.22	NA	\$32.77	\$45.27	\$45.34	\$45.43	\$55.00	
	2-Wire High Bit Rate Dig Subscriber Line (HDSL) Compatible Loop, without manual service inquiry and facility reservation, statewide, per month	UHL2W	NA	NA	NA	NA	NA	NA	\$11.98	NA	\$13.46	
	Zone 1, per month	UHL2W	\$9.41	\$9.80	\$7.88	\$6.29	\$8.97	\$8.50	TBD	\$12.21	TBD	
	Zone 2, per month	UHL2W	\$15.29	\$14.35	\$9.09	\$11.78	\$15.41	\$11.26	TBD	\$18.41	TBD	
	Zone 3, per month	UHL2W	\$27.70	\$31.65	\$14.48	\$20.33	\$31.48	\$16.10	TBD	\$24.39	TBD	
	Zone 4, per month	UHL2W	NA	NA	NA	NA	NA	\$21.25	NA	NA	NA	
	NRC - 1st	UHL2W	\$375.21	\$113.85	\$220.73	\$574.50	\$204.13	\$365.82	\$365.90	\$461.60	\$501.79	
	NRC - Add'l	UHL2W	\$325.58	\$99.61	\$186.15	\$470.44	\$171.03	\$317.24	\$317.17	\$368.33	\$402.94	
	NRC - Disconnect Charge - 1st	UHL2W	\$106.65	NA	NA	NA	\$72.54	\$105.86	NA	NA	NA	
	NRC - Disconnect Charge - Add'l	UHL2W	\$56.98	NA	NA	NA	\$39.42	\$57.25	NA	NA	NA	
	NRC - Incremental Charge - Manual Service Order - 1st	SOMAN	\$27.37	NA	\$18.94	NA	\$18.14	\$25.52	\$26.94	\$44.42	NA	
	NRC - Incremental Charge - Manual Service Order - Add'l	SOMAN	\$12.97	NA	\$8.42	NA	\$8.06	\$11.34	\$12.76	\$13.55	NA	
	NRC - Incremental Charge - Manual Service Order - Disconnect	SOMAN	\$17.77	NA	NA	NA	\$11.41	\$16.06	NA	NA	NA	
	NRC - Incremental Charge - Order Coordination - Time Specific (per LSR)	OCOSL	\$45.99	\$55.00	\$34.22	\$55.00	\$32.77	\$45.27	\$45.34	\$45.43	\$55.00	
	4-Wire High Bit Rate Dig Subscriber Line (HDSL) Compatible Loop, includes manual service inquiry and facility reservation, per month, statewide											
	RC - Statewide, per month	UHL4X	NA	NA	NA	NA	NA	NA	\$13.97	NA	\$17.91	
	RC - Zone 1, per month (Note 2)	UHL4X	\$11.52	\$14.75	\$10.39	\$7.68	\$12.97	\$10.36	TBD	\$16.21	\$15.46	
	RC - Zone 2, per month (Note 2)	UHL4X	\$18.71	\$21.59	\$12.00	\$14.38	\$21.76	\$13.73	TBD	\$24.45	\$19.46	
	RC - Zone 3, per month (Note 2)	UHL4X	\$33.90	\$47.64	\$19.07	\$24.82	\$44.44	\$19.62	TBD	\$32.38	\$27.88	
	RC - Zone 4, per month (Note 2)	UHL4X	NA	NA	NA	NA	NA	\$25.90	NA	NA	NA	
	NRC - 1st	UHL4X	\$541.13	\$116.91	\$378.86	NA	\$361.45	\$531.21	\$531.35	\$625.11	\$666.70	
	NRC - Add'l	UHL4X	\$491.50	\$101.71	\$344.28	NA	\$328.35	\$482.63	\$482.62	\$532.78	\$568.86	
	NRC - Disconnect Charge - 1st	UHL4X	\$106.65	NA	NA	NA	\$72.54	\$105.86	NA	NA	NA	
	NRC - Disconnect Charge - Add'l	UHL4X	\$56.98	NA	NA	NA	\$39.42	\$57.25	NA	NA	NA	
	NRC - Incremental Charge - Manual Service Order - 1st	SOMAN	\$27.37	NA	\$18.94	NA	\$18.14	\$25.52	\$26.94	\$44.06	NA	
	NRC - Incremental Charge - Manual Service Order - Add'l	SOMAN	\$12.97	NA	\$8.42	NA	\$8.06	\$11.34	\$12.76	\$13.55	NA	
	NRC - Incremental Charge - Manual Service Order - Disconnect	SOMAN	\$17.77	NA	NA	NA	\$11.41	\$16.06	NA	NA	NA	
	NRC - Incremental Charge - Order Coordination - Time Specific (per LSR)	OCOSL	\$45.99	\$55.00	\$34.22	NA	\$32.77	\$45.27	\$45.34	\$45.43	\$55.00	
	4-Wire High Bit Rate Dig Subscriber Line (HDSL) Compatible Loop, without manual service inquiry and facility reservation, per month, statewide	UHL4W	NA	NA	NA	NA	NA	NA	\$13.97	NA	\$17.91	
	Zone 1, per month	UHL4W	\$11.52	\$14.75	\$10.39	\$7.68	\$12.67	\$10.36	TBD	\$16.21	TBD	
	Zone 2, per month	UHL4W	\$18.71	\$21.59	\$12.00	\$14.38	\$21.76	\$13.73	TBD	\$24.45	TBD	
	Zone 3, per month	UHL4W	\$33.90	\$47.64	\$19.07	\$24.82	\$44.44	\$19.62	TBD	\$32.38	TBD	
	Zone 4, per month	UHL4W	NA	NA	NA	NA	NA	\$25.90	NA	NA	NA	
	NRC - 1st	UHL4W	\$402.13	\$116.91	\$239.86	\$609.93	\$222.45	\$392.21	\$392.35	\$486.11	\$527.70	
	NRC - Add'l	UHL4W	\$352.50	\$101.71	\$205.28	\$507.17	\$189.35	\$343.63	\$343.62	\$393.78	\$429.86	
	NRC - Disconnect Charge - 1st	UHL4W	\$106.65	NA	NA	NA	\$72.54	\$105.86	NA	NA	NA	
	NRC - Disconnect Charge - Add'l	UHL4W	\$56.98	NA	NA	NA	\$39.42	\$57.25	NA	NA	NA	
	NRC - Incremental Charge - Manual Service Order - 1st	SOMAN	\$27.37	NA	\$18.94	NA	\$18.14	\$25.52	\$26.94	\$44.06	NA	
	NRC - Incremental Charge - Manual Service Order - Add'l	SOMAN	\$12.97	NA	\$8.42	NA	\$8.06	\$11.34	\$12.76	\$13.55	NA	
	NRC - Incremental Charge - Manual Service Order - Disconnect	SOMAN	\$17.77	NA	NA	NA	\$11.41	\$16.06	NA	NA	NA	
	NRC - Incremental Charge - Order Coordination - Time Specific (per LSR)	OCOSL	\$45.99	\$55.00	\$34.22	\$55.00	\$32.77	\$45.27	\$45.34	\$45.43	\$55.00	

**BELLSOUTH/LEVEL 3 RATES
NETWORK ELEMENTS
AND OTHER SERVICES**

4-Wire DS1 Digital Loop, per month											
	RC - Statewide, per month	USLXX	NA	NA	NA	NA	NA	NA	\$62.78	NA	TBD
	RC - Zone 1, per month (Note 2)	USLXX	\$51.74	\$64.69	\$55.53	\$50.26	\$56.32	\$50.99	TBD	\$59.61	TBD
	RC - Zone 2, per month (Note 2)	USLXX	\$84.05	\$94.71	\$64.13	\$94.06	\$96.73	\$67.58	TBD	\$89.90	TBD
	RC - Zone 3, per month (Note 2)	USLXX	\$152.29	\$208.93	\$101.93	\$162.34	\$197.57	\$96.58	TBD	\$119.06	TBD
	RC - Zone 4, per month (Note 2)	USLXX	NA	NA	NA	NA	NA	\$127.47	NA	NA	NA
	NRC - 1st	USLXX	\$610.13	\$540.00	\$429.98	\$849.80	\$410.38	\$599.09	\$714.84	\$715.77	TBD
	NRC - Add'l	USLXX	\$380.26	\$465.00	\$268.18	\$523.27	\$255.48	\$373.90	\$421.47	\$421.50	TBD
	NRC - Disconnect Charge - 1st	USLXX	\$134.77	NA	NA	NA	\$92.35	\$133.53	NA	NA	NA
	NRC - Disconnect Charge - Add'l	USLXX	\$55.97	NA	NA	NA	\$38.44	\$56.25	NA	NA	NA
	NRC - Incremental Charge - Manual Service Order - 1st	SOMAN	\$27.37	NA	\$18.94	NA	\$18.14	\$25.52	\$26.94	\$43.77	NA
	NRC - Incremental Charge - Manual Service Order - Add'l	SOMAN	\$12.97	NA	\$8.42	NA	\$8.06	\$11.34	\$12.76	\$13.55	NA
	NRC - Incremental Charge - Manual Service Order - Disconnect	SOMAN	\$17.77	NA	NA	NA	\$11.41	\$16.06	NA	NA	NA
	NRC - Incremental Charge - Order Coordination - Time Specific (per LSR)	OCOSL	\$49.18	\$55.00	\$34.52	\$55.00	\$33.05	\$48.17	\$45.34	\$48.47	NA
4-Wire 56 Kbps Dig Grade Loop, per month											
	RC - Statewide, per month	UDL56	NA	NA	NA	NA	NA	NA	\$32.67	NA	\$42.23
	RC - Zone 1, per month (Note 2)	UDL56	\$27.33	\$39.08	\$25.75	NA	\$27.50	\$25.61	TBD	\$34.26	\$36.45
	RC - Zone 2, per month (Note 2)	UDL56	\$44.40	\$57.21	\$29.74	NA	\$47.24	\$33.94	TBD	\$51.67	\$45.87
	RC - Zone 3, per month (Note 2)	UDL56	\$80.45	\$126.22	\$47.27	NA	\$96.48	\$48.51	TBD	\$68.43	\$65.75
	RC - Zone 4, per month (Note 2)	UDL56	NA	NA	NA	NA	NA	\$64.02	NA	NA	NA
	NRC - 1st	UDL56	\$498.05	\$654.72	\$348.55	NA	\$333.28	\$489.00	\$489.04	\$602.73	\$643.00
	NRC - Add'l	UDL56	\$343.70	\$428.45	\$241.20	NA	\$230.50	\$337.93	\$337.51	\$393.50	\$421.26
	NRC - Disconnect Charge - 1st	UDL56	\$129.62	NA	NA	NA	\$87.99	\$128.36	NA	\$44.06	NA
	NRC - Disconnect Charge - Add'l	UDL56	\$64.25	NA	NA	NA	\$44.24	\$64.35	NA	\$13.55	NA
	NRC - Incremental Charge - Manual Service Order - 1st	SOMAN	\$27.37	NA	\$18.94	NA	\$18.14	\$25.52	\$26.94	NA	NA
	NRC - Incremental Charge - Manual Service Order - Add'l	SOMAN	\$12.97	NA	\$8.42	NA	\$8.06	\$11.34	\$12.76	NA	NA
	NRC - Incremental Charge - Manual Service Order - Disconnect	SOMAN	\$17.77	NA	NA	NA	\$11.41	\$16.06	NA	NA	NA
	NRC - Incremental Charge - Order Coordination - Time Specific (per LSR)	OCOSL	\$45.99	\$55.00	\$34.22	NA	\$32.77	\$45.27	\$45.34	\$45.43	\$55.00
4-Wire 64 Kbps Dig Grade Loop, per month											
	RC - Statewide, per month	UDL64	NA	NA	NA	NA	NA	NA	\$32.67	\$41.70	\$42.23
	RC - Zone 1, per month (Note 2)	UDL64	\$27.33	\$39.08	\$25.75	NA	\$27.50	\$25.61	TBD	\$34.26	\$36.45
	RC - Zone 2, per month (Note 2)	UDL64	\$44.40	\$57.21	\$29.74	NA	\$47.24	\$33.94	TBD	\$51.67	\$45.87
	RC - Zone 3, per month (Note 2)	UDL64	\$80.45	\$126.22	\$47.27	NA	\$96.48	\$48.51	TBD	\$68.43	\$65.75
	RC - Zone 4, per month (Note 2)	UDL64	NA	NA	NA	NA	NA	\$64.02	NA	NA	NA
	NRC - 1st	UDL64	\$498.05	\$654.72	\$348.55	NA	\$333.28	\$489.00	\$489.04	\$602.73	\$643.00
	NRC - Add'l	UDL64	\$343.70	\$428.45	\$241.20	NA	\$230.50	\$337.93	\$337.51	\$393.50	\$421.26
	NRC - Disconnect Charge - 1st	UDL64	\$129.62	NA	NA	NA	\$87.99	\$128.36	NA	\$44.06	NA
	NRC - Disconnect Charge - Add'l	UDL64	\$64.25	NA	NA	NA	\$44.24	\$64.35	NA	\$13.55	NA
	NRC - Incremental Charge - Manual Service Order - 1st	SOMAN	\$27.37	NA	\$18.94	NA	\$18.14	\$25.52	\$26.94	NA	NA
	NRC - Incremental Charge - Manual Service Order - Add'l	SOMAN	\$12.97	NA	\$8.42	NA	\$8.06	\$11.34	\$12.76	NA	NA
	NRC - Incremental Charge - Manual Service Order - Disconnect	SOMAN	\$17.77	NA	NA	NA	\$11.41	\$16.06	NA	NA	NA
	NRC - Incremental Charge - Order Coordination - Time Specific (per LSR)	OCOSL	\$45.99	\$55.00	\$34.22	NA	\$32.77	\$45.27	\$45.34	\$45.43	\$55.00
2-Wire Unbundled Copper Loop/Short (less than or equal to 18kft), includes manual service inquiry and facility reservation, per month, statewide *											
	RC - Statewide, per month	UCLPB	\$15.11	\$18.00	\$13.97	\$11.89	\$21.00	NA	\$19.00	\$20.81	\$12.16
	RC - Zone 1, per month (Note 2)	UCLPB	TBD	\$18.60	\$19.80	TBD	\$18.80	\$16.85	TBD	\$18.90	\$19.85
	RC - Zone 2, per month (Note 2)	UCLPB	TBD	\$27.23	\$22.86	TBD	\$25.85	\$22.34	TBD	\$28.50	\$24.98
	RC - Zone 3, per month (Note 2)	UCLPB	TBD	\$60.07	\$36.34	TBD	\$39.14	\$31.92	TBD	\$37.75	\$35.81
	RC - Zone 4, per month (Note 2)	UCLPB	NA	NA	NA	NA	NA	\$42.13	NA	NA	NA
	NRC - 1st	UCLPB	\$514.21	\$340.00	\$395.16	\$713.50	\$340.00	\$504.82	\$450.00	\$600.61	\$270.01
	NRC - Add'l	UCLPB	\$464.58	\$300.00	\$217.39	\$609.44	\$300.00	\$456.24	\$390.00	\$507.33	\$234.63
	NRC - Disconnect Charge - 1st	UCLPB	TBD	TBD	\$142.27	NA	\$72.54	\$105.86	NA	NA	\$74.54
	NRC - Disconnect Charge - Add'l	UCLPB	TBD	TBD	\$37.86	NA	\$39.42	\$57.25	NA	NA	\$39.14
	NRC - Incremental Charge - Manual Service Order - 1st	SOMAN	\$47.00	\$47.00	\$18.94	\$47.00	\$18.14	\$25.52	\$47.00	\$47.00	NA
	NRC - Incremental Charge - Manual Service Order - Add'l	SOMAN	\$21.00	\$21.00	\$8.42	\$21.00	\$8.06	\$11.34	\$21.00	\$25.52	NA

BELLSOUTH/LEVEL 3 RATES
NETWORK ELEMENTS
AND OTHER SERVICES

	NRC - Incremental Charge - Manual Service Order - Disconnect - 1st	SOMAN	\$17.77	NA	\$142.27	\$17.77	\$11.41	\$16.06	NA	\$21.00	NA	
	NRC - Incremental Charge - Manual Service Order - Disconnect - Add'l	SOMAN	\$17.77	NA	\$37.86	\$17.77	\$11.41	\$16.06	NA	\$21.00	NA	
	NRC - Incremental Charge - Manual Order Coordination - per loop	UCLMC	\$16.00	\$16.00	\$36.46	NA	\$32.77	\$45.27	\$16.00	\$45.43	\$34.29	
	2-Wire Unbundled Copper Loop/Short (less than or equal to 18kft), without manual service inquiry and facility reservation, per month, statewide											
		UCLPW	NA	NA	NA	NA	NA	NA	\$19.00	NA	\$12.16	
	Zone 1, per month	UCLPW	TBD	\$18.60	\$11.90	TBD	TBD	\$16.85	TBD	TBD	TBD	
	Zone 2, per month	UCLPW	TBD	\$27.23	\$13.74	TBD	TBD	\$22.34	TBD	TBD	TBD	
	Zone 3, per month	UCLPW	TBD	\$60.07	\$21.83	TBD	TBD	\$31.92	TBD	TBD	TBD	
	Zone 4, per month	UCLPW	NA	NA	NA	NA	NA	\$42.13	NA	NA	NA	
	NRC - 1st	UCLPW	\$375.21	\$201.00	\$154.13	\$574.50	\$201.00	\$365.82	\$311.00	\$461.61	\$131.01	
	NRC - Add'l	UCLPW	\$325.58	\$161.00	\$139.75	\$470.44	\$161.00	\$317.24	\$251.00	\$368.33	\$95.63	
	NRC - Disconnect Charge - 1st	UCLPW	TBD	TBD	\$140.73	NA	\$72.54	\$105.86	NA	NA	\$74.54	
	NRC - Disconnect Charge - Add'l	UCLPW	TBD	TBD	\$37.45	NA	\$39.42	\$57.25	NA	NA	\$39.14	
	NRC - Incremental Charge - Manual Service Order - 1st	SOMAN	\$47.00	\$47.00	NA	\$47.00	\$18.14	\$25.52	\$47.00	\$47.00	NA	
	NRC - Incremental Charge - Manual Service Order - Add'l	SOMAN	\$21.00	\$21.00	NA	\$21.00	\$8.06	\$11.34	\$21.00	\$25.52	NA	
	NRC - Incremental Charge - Manual Service Order - Disconnect - 1st	SOMAN	\$17.77	NA	NA	\$17.77	\$11.41	\$16.06	NA	\$21.00	NA	
	NRC - Incremental Charge - Manual Service Order - Disconnect - Add'l	SOMAN	\$17.77	NA	NA	\$17.77	\$11.41	\$16.06	NA	\$21.00	NA	
	NRC - Incremental Charge - Manual Order Coordination - per loop	UCLMC	\$16.00	\$16.00	\$36.46	NA	\$32.77	\$45.27	\$16.00	\$45.43	\$34.29	
	2-Wire Unbundled Copper Loop/Long (greater than 18kft), includes manual service inquiry and facility reservation, per month, statewide											
	RC - Statewide, per month	UCL2L	\$40.00	\$35.00	\$41.61	\$40.00	\$37.00	\$45.00	\$35.00	\$40.00	\$35.00	
	RC - Zone 1, per month (Note 2)	UCL2L	TBD	\$18.60	\$19.80	TBD	\$18.80	\$16.85	TBD	\$18.90	\$19.85	
	RC - Zone 2, per month (Note 2)	UCL2L	TBD	\$27.23	\$22.86	TBD	\$25.85	\$22.34	TBD	\$28.50	\$24.98	
	RC - Zone 3, per month (Note 2)	UCL2L	TBD	\$60.07	\$36.34	TBD	\$39.14	\$31.92	TBD	\$37.75	\$35.81	
	RC - Zone 4, per month (Note 2)	UCL2L	NA	NA	NA	NA	NA	\$42.13	NA	NA	NA	
	NRC - 1st	UCL2L	\$514.21	\$340.00	\$395.16	\$713.50	\$340.00	\$504.82	\$450.00	\$600.61	\$270.01	
	NRC - Add'l	UCL2L	\$464.58	\$300.00	\$217.39	\$609.44	\$300.00	\$456.24	\$390.00	\$507.33	\$234.63	
	NRC - Disconnect Charge - 1st	UCL2L	NA	NA	\$142.27	NA	\$72.54	\$105.86	NA	NA	\$74.54	
	NRC - Disconnect Charge - Add'l	UCL2L	NA	NA	\$37.86	NA	\$39.42	\$57.25	NA	NA	\$39.14	
	NRC - Incremental Charge - Manual Service Order - 1st	SOMAN	\$47.00	\$47.00	\$18.94	\$47.00	\$18.14	\$25.52	\$47.00	\$47.00	NA	
	NRC - Incremental Charge - Manual Service Order - Add'l	SOMAN	\$21.00	\$21.00	\$8.42	\$21.00	\$8.06	\$11.34	\$21.00	\$25.52	NA	
	NRC - Incremental Charge - Manual Service Order - Disconnect - 1st	SOMAN	\$17.77	NA	\$142.27	\$17.77	\$11.41	\$16.06	NA	\$21.00	NA	
	NRC - Incremental Charge - Manual Service Order - Disconnect - Add'l	SOMAN	\$17.77	NA	\$37.86	\$17.77	\$11.41	\$16.06	NA	\$21.00	NA	
	NRC - Incremental Charge - Manual Order Coordination - per loop	UCLMC	\$16.00	\$16.00	\$36.46	NA	\$32.77	\$45.27	\$16.00	\$45.43	\$34.29	
	2-Wire Unbundled Copper Loop/Long (greater than 18kft), without manual service inquiry and facility reservation, per month, statewide											
		UCL2W	\$40.00	\$35.00	\$37.00	\$40.00	\$37.00	\$45.00	\$35.00	\$40.00	\$35.00	
	Zone 1, per month	UCL2W	TBD	TBD	TBD	TBD	TBD	TBD	TBD	TBD	TBD	
	Zone 2, per month	UCL2W	TBD	TBD	TBD	TBD	TBD	TBD	TBD	TBD	TBD	
	Zone 3, per month	UCL2W	TBD	TBD	TBD	TBD	TBD	TBD	TBD	TBD	TBD	
	Zone 4, per month	UCL2W	NA	NA	NA	NA	NA	NA	NA	NA	NA	
	NRC - 1st	UCL2W	\$375.21	\$201.00	\$154.13	\$574.50	\$201.00	\$365.82	\$311.00	\$461.61	\$131.01	
	NRC - Add'l	UCL2W	\$325.58	\$161.00	\$139.75	\$470.44	\$161.00	\$317.24	\$251.00	\$368.33	\$95.63	
	NRC - Disconnect Charge - 1st	UCL2W	NA	NA	TBD	NA	\$72.54	\$105.86	NA	NA	\$74.54	
	NRC - Disconnect Charge - Add'l	UCL2W	NA	NA	TBD	NA	\$39.42	\$57.25	NA	NA	\$39.14	
	NRC - Incremental Charge - Manual Service Order - 1st	SOMAN	\$47.00	\$47.00	TBD	\$47.00	\$18.14	\$25.52	\$47.00	\$47.00	NA	
	NRC - Incremental Charge - Manual Service Order - Add'l	SOMAN	\$21.00	\$21.00	TBD	\$21.00	\$8.06	\$11.34	\$21.00	\$25.52	NA	
	NRC - Incremental Charge - Manual Service Order - Disconnect - 1st	SOMAN	\$17.77	NA	TBD	\$17.77	\$11.41	\$16.06	NA	\$21.00	NA	
	NRC - Incremental Charge - Manual Service Order - Disconnect - Add'l	SOMAN	\$17.77	NA	TBD	\$17.77	\$11.41	\$16.06	NA	\$21.00	NA	
	NRC - Incremental Charge - Manual Order Coordination - per loop	UCLMC	\$16.00	\$16.00	36.46	NA	\$32.77	\$45.27	\$16.00	\$45.43	\$34.29	

BELLSOUTH/LEVEL 3 RATES
NETWORK ELEMENTS
AND OTHER SERVICES

4-Wire Unbundled Copper Loop/Short (less than or equal to 18kft), <u>includes</u> manual service inquiry and facility reservation, per month, statewide *		UCL4S	TBD	TBD	\$19.34	TBD	TBD	TBD	TBD	TBD	TBD
	Zone 1, per month	UCL4S	TBD	TBD	\$16.65	TBD	TBD	TBD	TBD	TBD	TBD
	Zone 2, per month	UCL4S	TBD	TBD	\$19.22	TBD	TBD	TBD	TBD	TBD	TBD
	Zone 3, per month	UCL4S	TBD	TBD	\$30.55	TBD	TBD	TBD	TBD	TBD	TBD
	Zone 4, per month	UCL4S	NA	NA	NA	NA	NA	TBD	NA	NA	NA
	NRC - 1st	UCL4S	TBD	TBD	\$353.80	TBD	TBD	TBD	TBD	TBD	TBD
	NRC - Add'l	UCL4S	TBD	TBD	\$162.61	TBD	TBD	TBD	TBD	TBD	TBD
	NRC - Disconnect Charge - 1st	UCL4S	TBD	TBD	\$156.25	TBD	TBD	TBD	TBD	TBD	TBD
	NRC - Disconnect Charge - Add'l	UCL4S	TBD	TBD	\$41.96	TBD	TBD	TBD	TBD	TBD	TBD
	NRC - Incremental Charge - Manual Service Order - 1st	SOMAN	TBD	TBD	NA	TBD	TBD	TBD	TBD	TBD	TBD
	NRC - Incremental Charge - Manual Service Order - Add'l	SOMAN	TBD	TBD	NA	TBD	TBD	TBD	TBD	TBD	TBD
	NRC - Incremental Charge - Manual Service Order - Disconnect	SOMAN	TBD	TBD	NA	TBD	TBD	TBD	TBD	TBD	TBD
	NRC - Incremental Charge - Manual Order Coordination - per loop	UCLMC	TBD	TBD	\$36.46	TBD	TBD	TBD	TBD	TBD	TBD
4-Wire Unbundled Copper Loop/Short (less than or equal to 18kft), <u>without</u> manual service inquiry and facility reservation, per month, statewide		UCL4W	TBD	TBD	\$19.34	TBD	TBD	TBD	TBD	TBD	TBD
	Zone 1, per month	UCL4W	TBD	TBD	\$16.65	TBD	TBD	TBD	TBD	TBD	TBD
	Zone 2, per month	UCL4W	TBD	TBD	\$19.22	TBD	TBD	TBD	TBD	TBD	TBD
	Zone 3, per month	UCL4W	TBD	TBD	\$30.55	TBD	TBD	TBD	TBD	TBD	TBD
	Zone 4, per month	UCL4W	NA	NA	NA	NA	NA	NA	NA	NA	NA
	NRC - 1st	UCL4W	TBD	TBD	\$214.80	TBD	TBD	TBD	TBD	TBD	TBD
	NRC - Add'l	UCL4W	TBD	TBD	\$162.61	TBD	TBD	TBD	TBD	TBD	TBD
	NRC - Disconnect Charge - 1st	UCL4W	TBD	TBD	\$156.25	TBD	TBD	TBD	TBD	TBD	TBD
	NRC - Disconnect Charge - Add'l	UCL4W	TBD	TBD	\$41.96	TBD	TBD	TBD	TBD	TBD	TBD
	NRC - Incremental Charge - Manual Service Order - 1st	SOMAN	TBD	TBD	NA	TBD	TBD	TBD	TBD	TBD	TBD
	NRC - Incremental Charge - Manual Service Order - Add'l	SOMAN	TBD	TBD	NA	TBD	TBD	TBD	TBD	TBD	TBD
	NRC - Incremental Charge - Manual Service Order - Disconnect	SOMAN	TBD	TBD	NA	TBD	TBD	TBD	TBD	TBD	TBD
	NRC - Incremental Charge - Manual Order Coordination - per loop	UCLMC	TBD	TBD	\$36.46	TBD	TBD	TBD	TBD	TBD	TBD
4-Wire Unbundled Copper Loop/Long (greater than 18kft), <u>includes</u> manual service inquiry and reservation, per month, statewide		UCL4L	TBD	TBD	\$55.86	TBD	TBD	TBD	TBD	TBD	TBD
	Zone 1, per month	UCL4L	TBD	TBD	\$47.56	TBD	TBD	TBD	TBD	TBD	TBD
	Zone 2, per month	UCL4L	TBD	TBD	\$54.92	TBD	TBD	TBD	TBD	TBD	TBD
	Zone 3, per month	UCL4L	TBD	TBD	\$87.30	TBD	TBD	TBD	TBD	TBD	TBD
	Zone 4, per month	UCL4L	NA	NA	NA	NA	NA	TBN	NA	NA	NA
	NRC - 1st	UCL4L	TBD	TBD	\$397.06	TBD	TBD	TBD	TBD	TBD	TBD
	NRC - Add'l	UCL4L	TBD	TBD	\$227.88	TBD	TBD	TBD	TBD	TBD	TBD
	NRC - Disconnect Charge - 1st	UCL4L	TBD	TBD	\$156.25	TBD	TBD	TBD	TBD	TBD	TBD
	NRC - Disconnect Charge - Add'l	UCL4L	TBD	TBD	\$41.96	TBD	TBD	TBD	TBD	TBD	TBD
	NRC - Incremental Charge - Manual Service Order - 1st	SOMAN	TBD	TBD	NA	TBD	TBD	TBD	TBD	TBD	TBD
	NRC - Incremental Charge - Manual Service Order - Add'l	SOMAN	TBD	TBD	NA	TBD	TBD	TBD	TBD	TBD	TBD
	NRC - Incremental Charge - Manual Service Order - Disconnect	SOMAN	TBD	TBD	NA	TBD	TBD	TBD	TBD	TBD	TBD
	NRC - Incremental Charge - Manual Order Coordination - per loop	UCLMC	TBD	TBD	\$36.46	TBD	TBD	TBD	TBD	TBD	TBD
4-Wire Unbundled Copper Loop/Long (greater than 18kft), <u>without</u> manual service inquiry and facility reservation, per month, statewide		UCL4O	TBD	TBD	\$55.86	TBD	TBD	TBD	TBD	TBD	TBD
	Zone 1, per month	UCL4O	TBD	TBD	\$47.56	TBD	TBD	TBD	TBD	TBD	TBD
	Zone 2, per month	UCL4O	TBD	TBD	\$54.92	TBD	TBD	TBD	TBD	TBD	TBD
	Zone 3, per month	UCL4O	TBD	TBD	\$87.30	TBD	TBD	TBD	TBD	TBD	TBD
	Zone 4, per month	UCL4O	NA	NA	NA	NA	NA	TBN	NA	NA	NA
	NRC - 1st	UCL4O	TBD	TBD	\$397.06	TBD	TBD	TBD	TBD	TBD	TBD
	NRC - Add'l	UCL4O	TBD	TBD	\$227.88	TBD	TBD	TBD	TBD	TBD	TBD
	NRC - Disconnect Charge - 1st	UCL4O	TBD	TBD	\$156.25	TBD	TBD	TBD	TBD	TBD	TBD
	NRC - Disconnect Charge - Add'l	UCL4O	TBD	TBD	\$41.96	TBD	TBD	TBD	TBD	TBD	TBD
	NRC - Incremental Charge - Manual Service Order - 1st	SOMAN	TBD	TBD	NA	TBD	TBD	TBD	TBD	TBD	TBD

BELLSOUTH/LEVEL 3 RATES
NETWORK ELEMENTS
AND OTHER SERVICES

	NRC - Incremental Charge - Manual Service Order - Add'l	SOMAN	TBD	TBD	NA	TBD	TBD	TBD	TBD	TBD	TBD	TBD
	NRC - Incremental Charge - Manual Service Order - Disconnect	SOMAN	TBD	TBD	NA	TBD	TBD	TBD	TBD	TBD	TBD	TBD
	NRC - Incremental Charge - Manual Order Coordination - per loop	UCLMC	TBD	TBD	\$36.46	TBD	TBD	TBD	TBD	TBD	TBD	TBD
	DS3 Local Loop											
	DS3 Unbundled Local Loop - per mile	1L5ND	\$10.85	\$11.97	\$8.90	\$43.69	\$11.26	\$54.39	\$11.40	\$15.53	\$30.53	
	DS3 Unbundled Local Loop- per Facility Termination	UE3PX	\$419.65	\$407.58	\$390.34	\$436.95	\$439.59	\$427.81	\$413.09	\$421.60	\$400.21	
	NRC - Facility Termination - 1st	UE3PX	\$640.54	\$910.45	\$639.50	\$1,091.00	\$594.70	\$975.22	\$757.25	\$735.42	\$726.16	
	NRC - Facility Termination - Add'l	UE3PX	\$426.82	\$532.19	\$426.40	\$661.23	\$396.54	\$549.17	\$534.95	\$519.31	\$411.64	
	NRC - Facility Termination - Disconnect - 1st	UE3PX	\$121.72	\$223.20	\$122.31	NA	\$102.16	\$134.07	NA	NA	\$103.36	
	NRC - Facility Termination - Disconnect - Add'l	UE3PX	\$118.54	\$156.12	\$119.14	NA	\$99.46	\$130.59	NA	NA	\$100.59	
	NRC - Manual Svc Order, per LSR	SOMAN	NA	\$21.73	NA	\$19.99	NA	NA	NA	NA	\$19.99	
	NRC - Manual Svc Order, per LSR disconnect	SOMAN	NA	\$3.87	NA	NA	NA	NA	NA	NA	NA	
	NRC - Electronic Svc Order, per LSR	SOMEC	\$3.50	\$2.77	\$3.50	\$3.50	\$3.50	\$3.50	\$3.50	\$3.50	\$3.50	
	NRC - Electronic Svc Order, per LSR disconnect	SOMEC	NA	\$0.43	NA	NA	NA	NA	NA	NA	NA	
	NRC - Incremental Charge-Manual Svc Order - 1st	SOMAN	\$38.48	NA	\$37.55	NA	\$34.92	\$68.62	\$55.00	\$54.26	NA	
	NRC - Incremental Charge-Manual Svc Order - Add'l	SOMAN	\$38.48	NA	\$37.55	NA	\$34.92	\$68.62	\$55.00	\$54.26	NA	
	NRC - Incremental Cost - Manual Svc. Order vs. Elect-Disconnect-1st	SOMAN	\$19.03	NA	\$18.03	NA	\$20.94	\$28.59	NA	NA	NA	
	NRC - Incremental Cost - Manual Svc. Order vs. Elect-Disconnect-Add'l	SOMAN	\$19.03	NA	\$18.03	NA	\$20.94	\$28.59	NA	NA	NA	
	STS-1 Local Loop											
	STS-1 Unbundled Local Loop - per mile	1L5ND	\$10.85	\$11.97	\$8.90	\$43.69	\$11.29	\$54.39	\$11.40	\$15.53	\$30.53	
	STS-1 Unbundled Local Loop- per Facility Termination	UDLS1	\$434.31	\$449.40	\$390.34	\$436.95	\$454.28	\$427.81	\$428.93	\$431.32	\$400.21	
	NRC - STS-1 - Facility Termination - 1st	UDLS1	\$640.54	\$910.45	\$639.50	\$1,091	\$594.71	\$975.22	\$757.25	\$735.42	\$726.16	
	NRC - STS-1 - Facility Termination - Add'l	UDLS1	\$426.82	\$532.19	\$426.40	\$661.23	\$396.54	\$549.17	\$534.95	\$519.31	\$411.64	
	NRC - STS-1 - Facility Termination - Disconnect - 1st	UDLS1	\$121.72	\$223.20	\$122.31	NA	\$113.75	\$134.07	NA	NA	\$103.36	
	NRC - STS-1 - Facility Termination - Disconnect - Add'l	UDLS1	\$118.54	\$156.12	\$119.14	NA	\$110.80	\$130.59	NA	NA	\$100.59	
	NRC - Manual Svc Order, per LSR	SOMAN	NA	\$21.73	NA	\$19.99	NA	NA	NA	NA	\$19.99	
	NRC - Manual Svc Order, per LSR disconnect	SOMAN	NA	\$3.87	NA	NA	NA	NA	NA	NA	NA	
	NRC - Electronic Svc Order, per LSR	SOMEC	\$3.50	\$2.77	\$3.50	\$3.50	\$3.50	\$3.50	\$3.50	\$3.50	\$3.50	
	NRC - Electronic Svc Order, per LSR disconnect	SOMEC	NA	\$0.43	NA	NA	NA	NA	NA	NA	NA	
	NRC - STS-1 - Incremental Charge-Manual Svc Order - 1st	SOMAN	\$38.48	NA	\$37.55	NA	\$34.92	\$68.62	\$55.00	\$54.26	NA	
	NRC - STS-1 - Incremental Charge-Manual Svc Order - Add'l	SOMAN	\$38.48	NA	\$37.55	NA	\$34.92	\$68.62	\$55.00	\$54.26	NA	
	NRC - STS-1 - Incremental Cost - Manual Svc. Order vs. Elect-Disconnect-1st	SOMAN	\$19.03	NA	\$18.03	NA	\$16.77	\$28.59	NA	NA	NA	
	NRC - STS-1 - Incremental Cost - Manual Svc. Order vs. Elect-Disconnect-Add'l	SOMAN	\$19.03	NA	\$18.03	NA	\$16.77	\$28.59	NA	NA	NA	
	OC3- Local Loop											
	Local Loop - OC3 - per Mile	TBD	\$8.23	\$9.08	\$6.75	\$33.15	\$29.58	\$41.27	\$24.69	\$11.78	\$23.16	
	Local Loop - OC3 - per Facility Termination	TBD	\$691.33	\$651.40	\$630.21	\$713.29	\$753.65	\$689.68	\$611.36	\$701.71	\$620.20	
	NRC - OC3 - Facility Termination - 1st	TBD	\$949.63	\$974.02	\$947.69	\$1,543	\$1,025	\$1,427	\$1,411	\$1,044	\$1,050	
	NRC - OC3 - Facility Termination - Add'l	TBD	\$413.38	\$412.05	\$413.00	\$661.23	\$402.63	\$549.17	\$542.73	\$505.88	\$411.64	
	NRC - OC3 - Facility Termination - Disconnect - 1st	TBD	\$121.72	\$112.44	\$122.31	NA	\$102.16	\$134.07	\$131.65	NA	\$103.36	
	NRC - OC3 - Facility Termination - Disconnect - Add'l	TBD	\$118.54	\$109.19	\$119.14	NA	\$99.46	\$130.59	\$128.19	NA	\$100.59	
	NRC - Manual Svc Order, per LSR	SOMAN	NA	\$21.73	NA	\$19.99	NA	NA	NA	NA	\$19.99	
	NRC - Manual Svc Order, per LSR disconnect	SOMAN	NA	\$3.87	NA	NA	NA	NA	NA	NA	NA	
	NRC - Electronic Svc Order, per LSR	SOMEC	\$3.50	\$2.77	\$3.50	\$3.50	\$3.50	\$3.50	\$3.50	\$3.50	\$3.50	
	NRC - Electronic Svc Order, per LSR disconnect	SOMEC	NA	\$0.43	NA	NA	NA	NA	NA	NA	NA	
	NRC - OC3 - Incremental Charge-Manual Svc Order - 1st	SOMAN	\$38.48	NA	\$37.55	\$93.12	\$50.25	\$68.62	\$69.34	\$54.26	NA	
	NRC - OC3 - Incremental Charge-Manual Svc Order - Add'l	SOMAN	\$38.48	NA	\$37.55	\$93.12	\$50.25	\$68.62	\$69.34	\$54.26	NA	
	NRC - OC3 -Incremental Cost - Manual Svc. Order vs. Elect-Disconnect-1st	SOMAN	\$19.03	NA	\$18.03	NA	\$20.94	\$28.59	\$29.76	NA	NA	
	NRC - OC3 -Incremental Cost - Manual Svc. Order vs. Elect-Disconnect-Add'l	SOMAN	\$19.03	NA	\$18.03	NA	\$20.94	\$28.59	\$29.76	NA	NA	
	OC-12 Local Loop											
	Local Loop - OC12 - per Mile	TBD	\$10.13	\$11.18	\$8.31	\$40.80	\$36.40	\$50.79	\$30.38	\$14.50	\$28.51	
	Local Loop - OC12 - per Facility Termination	TBD	\$2,557	\$2,068	\$2,109.00	\$2,457	\$2,571	\$2,371	\$2,122	\$2,663	\$2,079	
	NRC - OC12 - Facility Termination - 1st	TBD	\$1,165	\$1,193	\$1,162.00	\$1,858	\$1,245	\$1,742	\$1,722	\$1,259	\$1,276	
	NRC - OC12 - Facility Termination - Add'l	TBD	\$413.38	\$412.05	\$413.00	\$661.23	\$402.63	\$549.17	\$542.73	\$505.88	\$411.64	
	NRC - OC12 - Facility Termination - Disconnect - 1st	TBD	\$121.72	\$112.44	\$122.31	NA	\$102.16	\$134.07	\$131.65	NA	\$103.36	
	NRC - OC12 - Facility Termination - Disconnect - Add'l	TBD	\$118.54	\$109.19	\$119.14	NA	\$99.46	\$130.59	\$128.19	NA	\$100.59	
	NRC - Manual Svc Order, per LSR	SOMAN	NA	\$21.73	NA	\$19.99	NA	NA	NA	NA	\$19.99	

**BELLSOUTH/LEVEL 3 RATES
NETWORK ELEMENTS
AND OTHER SERVICES**

	NRC - Manual Svc Order, per LSR disconnect	SOMAN	NA	\$3.87	NA	NA	NA	NA	NA	NA	NA	NA
	NRC - Electronic Svc Order, per LSR	SOMEK	\$3.50	\$2.77	\$3.50	\$3.50	\$3.50	\$3.50	\$3.50	\$3.50	\$3.50	\$3.50
	NRC - Electronic Svc Order, per LSR disconnect	SOMEK	NA	\$0.43	NA	NA	NA	NA	NA	NA	NA	NA
	NRC -OC12 - Incremental Charge - Manual Svc Order - 1st	SOMAN	\$38.48	NA	\$37.55	\$93.12	\$50.25	\$68.62	\$69.34	\$54.26	NA	NA
	NRC - OC12 - Incremental Charge - Manual Svc Order - Add'l	SOMAN	\$38.48	NA	\$37.55	\$93.12	\$50.25	\$68.62	\$69.34	\$54.26	NA	NA
	NRC - OC12 - Incremental Cost-Manual Svc. Order vs. Elect-Disconnect-1st	SOMAN	\$19.03	NA	\$18.03	NA	\$20.94	\$28.59	\$29.76	NA	NA	NA
	NRC - OC12 - Incremental Cost-Manual Svc. Order vs. Elect-Disconnect-Add'l	SOMAN	\$19.03	NA	\$18.03	NA	\$20.94	\$28.59	\$29.76	NA	NA	NA
OC - 48 Local Loop												
	Local Loop - OC48 - per Mile	TBD	\$33.22	\$36.67	\$27.25	\$133.84	\$119.40	\$166.59	\$120.02	\$47.57	\$93.50	NA
	Local Loop - OC48 - per Facility Termination	TBD	\$1,713	\$1,699	\$1,598.00	\$2,129	\$2,268	\$1,753	\$1,677	\$1,733	\$1,832	NA
	Local Loop - OC12 interface on OC48 Facility	TBD	\$736.71	\$592.09	\$594.80	\$725.77	\$723.29	\$667.00	\$582.66	\$773.40	\$570.54	NA
	NRC - OC48 - Facility Termination - 1st	TBD	\$1,165	\$1,193	\$1,162.00	\$1,858	\$1,245	\$1,742	\$1,722	\$1,259	\$1,276	NA
	NRC - OC48 - Facility Termination - Add'l	TBD	\$413.38	\$412.05	\$413.00	\$661.23	\$402.63	\$549.17	\$542.73	\$505.88	\$411.64	NA
	NRC - OC48 - Interface OC12 on OC48 - 1st	TBD	\$121.72	\$472.77	\$539.36	\$844.21	\$532.13	\$729.04	\$720.81	\$635.04	\$544.55	NA
	NRC - OC48 - Interface OC12 on OC48 - Add'l	TBD	\$118.54	\$329.91	\$317.38	\$516.89	\$304.90	\$404.94	\$400.38	\$410.02	\$311.39	NA
	NRC - OC48 - Facility Termination - Disconnect - 1st	TBD	\$121.72	\$108.95	\$122.31	NA	\$102.16	\$134.07	\$131.65	NA	\$103.36	NA
	NRC - OC48 - Facility Termination - Disconnect - Add'l	TBD	\$118.54	\$106.01	\$119.14	NA	\$99.46	\$130.59	\$128.19	NA	\$100.59	NA
	NRC - OC48 - Interface OC12 on OC48 - Disconnect - 1st	TBD	\$121.72	\$108.95	\$122.31	NA	\$102.16	\$134.07	\$131.65	NA	\$103.36	NA
	NRC - OC48 - Interface OC12 on OC48 - Disconnect - Add'l	TBD	\$118.54	\$106.01	\$119.14	NA	\$99.46	\$130.59	\$128.19	NA	\$100.59	NA
	NRC - Manual Svc Order, per LSR	SOMAN	NA	\$21.73	NA	\$19.99	NA	NA	NA	NA	NA	\$19.99
	NRC - Manual Svc Order, per LSR disconnect	SOMAN	NA	\$3.87	NA	NA	NA	NA	NA	NA	NA	NA
	NRC - Electronic Svc Order, per LSR	SOMEK	\$3.50	\$2.77	\$3.50	\$3.50	\$3.50	\$3.50	\$3.50	\$3.50	\$3.50	\$3.50
	NRC - Electronic Svc Order, per LSR disconnect	SOMEK	NA	\$0.43	NA	NA	NA	NA	NA	NA	NA	NA
	NRC - OC48 - Facility Termination-Manual Svc Order vs Electronic-Disconnect-1st	SOMAN	\$19.03	NA	\$37.55	NA	\$20.94	\$28.59	\$29.76	NA	NA	NA
	NRC - OC48 - Facility Termination-Manual Svc Order vs Electronic-Disconnect-Add'l	SOMAN	\$19.03	NA	\$37.55	NA	\$20.94	\$28.59	\$29.76	NA	NA	NA
	NRC - OC48 - Interface - Manual Svc Order vs Electronic-Disconnect-1st	SOMAN	\$19.03	NA	\$37.55	NA	\$20.94	\$28.59	\$29.76	NA	NA	NA
	NRC - OC48 - Interface - Manual Svc Order vs Electronic-Disconnect-Add'l	SOMAN	\$19.03	NA	\$37.55	NA	\$20.94	\$28.59	\$29.76	NA	NA	NA
	NRC - OC-48 - Incremental Charge--Manual Svc Order-1st	SOMAN	\$38.48	NA	\$18.03	\$93.12	\$50.25	\$68.62	\$69.34	\$54.26	NA	NA
	NRC - OC-48 - Incremental Charge--Manual Svc Order-Add'l	SOMAN	\$38.48	NA	\$18.03	\$93.12	\$50.25	\$68.62	\$69.34	\$54.26	NA	NA
	NRC - OC48 - Interface OC12 on OC48 - Incremental Charge--Manual Svc Order	SOMAN	\$38.48	NA	\$18.03	\$93.12	\$50.25	\$68.62	\$69.34	NA	NA	NA
	NRC - OC48 - Interface OC12 on OC48 - Incremental Charge--Manual Svc Order-Add'l	SOMAN	\$38.48	NA	\$18.03	\$93.12	\$50.25	\$68.62	\$69.34	NA	NA	NA
Unbundled Loop Modification												
	NRC - Load Coil/Equipment Removal per 2 Wire pair - Loops less than or equal to 18kft	ULM2L	\$80.55	\$80.55	\$69.28	\$80.55	\$80.55	\$80.55	\$80.55	\$80.55	\$80.55	\$80.55
	NRC - Load Coil/Equipment Removal per 2 Wire pair - Loops greater than 18kft 1st	ULM2G	\$880.00	\$880.00	\$757.04	\$880.00	\$880.00	\$880.00	\$880.00	\$880.00	\$880.00	\$880.00
	NRC - Load Coil/Equipment Removal per 2 Wire pair - Loops greater than 18kft Add'l	ULM2G	\$27.30	\$27.30	\$23.49	\$27.30	\$27.30	\$27.30	\$27.30	\$27.30	\$27.30	\$27.30
	NRC - Load Coil/Equipment Removal per 4 Wire pair - Loops less than or equal to 18kft	ULM4G	TBN	TBN	TBN	TBN	TBN	TBN	TBN	TBN	TBN	TBN
	NRC - Load Coil/Equipment Removal per 4 Wire pair - Loops greater than 18kft 1st	ULM4L	TBN	TBN	TBN	TBN	TBN	TBN	TBN	TBN	TBN	TBN
	NRC - Load Coil/Equipment Removal per 4 Wire pair - Loops greater than 18kft Add'l	ULM4L	TBN	TBN	TBN	TBN	TBN	TBN	TBN	TBN	TBN	TBN
	NRC - Bridge Tap Removal per pair unloaded	ULMBT	\$121.14	\$121.14	\$79.99	\$121.14	\$121.14	\$121.14	\$121.14	\$121.14	\$121.14	\$121.14
UNBUNDLED SUB-LOOPS												
SUB-LOOP DISTRIBUTION												
Cross-Box Set-Up												
	NRC - Set-Up per Cross Box location in the field - CLEC Feeder Facility set-up	USBSA	TBN	TBN	\$421.08	TBN	TBN	TBN	TBN	TBN	TBN	TBN
	NRC - Set-Up per Cross Box location in the field - per 25 pair panel set-up	USBSB	TBN	TBN	\$67.10	TBN	TBN	TBN	TBN	TBN	TBN	TBN
	NRC - Set-Up per Building Equipment Room - CLEC Feeder Facility set-up	USBSC	TBN	TBN	\$394.74	TBN	TBN	TBN	TBN	TBN	TBN	TBN
	NRC - Set-Up per Building Equipment Room - per 25 pair panel set-up	USBSD	TBN	TBN	\$154.57	TBN	TBN	TBN	TBN	TBN	TBN	TBN

BELLSOUTH/LEVEL 3 RATES
NETWORK ELEMENTS
AND OTHER SERVICES

Loop Distribution per 2-Wire Analog VG Sub-Loop, per month		USBN2	TBN	TBN	\$9.12	\$10.83	TBN	TBN	TBN	TBN	TBN	TBN
	NRC - 1st	USBN2	TBN	TBN	\$207.01	\$459.85	TBN	TBN	TBN	TBN	TBN	TBN
	NRC - Add'l	USBN2	TBN	TBN	\$171.32	\$352.89	TBN	TBN	TBN	TBN	TBN	TBN
	NRC - Disconnect Charge - 1st	USBN2	TBN	TBN	TBD	TBN	TBN	TBN	TBN	TBN	TBN	TBN
	NRC - Disconnect Charge - Add'l	USBN2	TBN	TBN	TBD	TBN	TBN	TBN	TBN	TBN	TBN	TBN
	NRC - Incremental Charge - Manual Service Order - 1st	SOMAN	TBN	TBN	\$18.94	TBN	TBN	TBN	TBN	TBN	TBN	TBN
	NRC - Incremental Charge - Manual Service Order - Add'l	SOMAN	TBN	TBN	\$8.42	TBN	TBN	TBN	TBN	TBN	TBN	TBN
	NRC - Incremental Charge - Manual Service Order - Disconnect	SOMAN	TBN	TBN	TBD	TBN	TBN	TBN	TBN	TBN	TBN	TBN
	NRC - Incremental Charge - Manual Order Coordination - per loop	USBMC	TBN	TBN	\$34.22	TBN	TBN	TBN	TBN	TBN	TBN	TBN
Loop Distribution per 4-Wire Analog VG Sub-Loop, per month		USBN4	TBN	TBN	\$8.32	TBN	TBN	TBN	TBN	TBN	TBN	TBN
	NRC - 1st	USBN4	TBN	TBN	\$219.35	TBN	TBN	TBN	TBN	TBN	TBN	TBN
	NRC - Add'l	USBN4	TBN	TBN	\$72.99	TBN	TBN	TBN	TBN	TBN	TBN	TBN
	NRC - Disconnect Charge - 1st	USBN4	TBN	TBN	\$123.72	TBN	TBN	TBN	TBN	TBN	TBN	TBN
	NRC - Disconnect Charge - Add'l	USBN4	TBN	TBN	\$28.77	TBN	TBN	TBN	TBN	TBN	TBN	TBN
	NRC - Incremental Charge - Manual Service Order - 1st	SOMAN	TBN	TBN	NA	TBN	TBN	TBN	TBN	TBN	TBN	TBN
	NRC - Incremental Charge - Manual Service Order - Add'l	SOMAN	TBN	TBN	NA	TBN	TBN	TBN	TBN	TBN	TBN	TBN
	NRC - Incremental Charge - Manual Service Order - Disconnect	SOMAN	TBN	TBN	NA	TBN	TBN	TBN	TBN	TBN	TBN	TBN
	NRC - Incremental Charge - Manual Order Coordination - per loop	USBMC	TBN	TBN	\$34.22	TBN	TBN	TBN	TBN	TBN	TBN	TBN
Loop Distribution per 2 Wire Unbundled Copper Sub-Loop, per month		UCS2X	TBN	TBN	TBN	TBN	TBN	TBN	TBN	TBN	TBN	TBN
	NRC - 1st	UCS2X	TBN	TBN	TBN	TBN	TBN	TBN	TBN	TBN	TBN	TBN
	NRC - Add'l	UCS2X	TBN	TBN	TBN	TBN	TBN	TBN	TBN	TBN	TBN	TBN
	NRC - Disconnect Charge - 1st	UCS2X	TBN	TBN	TBN	TBN	TBN	TBN	TBN	TBN	TBN	TBN
	NRC - Disconnect Charge - Add'l	UCS2X	TBN	TBN	TBN	TBN	TBN	TBN	TBN	TBN	TBN	TBN
	NRC - Incremental Charge - Manual Service Order - 1st	SOMAN	TBN	TBN	TBN	TBN	TBN	TBN	TBN	TBN	TBN	TBN
	NRC - Incremental Charge - Manual Service Order - Add'l	SOMAN	TBN	TBN	TBN	TBN	TBN	TBN	TBN	TBN	TBN	TBN
	NRC - Incremental Charge - Manual Service Order - Disconnect	SOMAN	TBN	TBN	TBN	TBN	TBN	TBN	TBN	TBN	TBN	TBN
	NRC - Incremental Charge - Manual Order Coordination - per loop	USBMC	TBN	TBN	TBN	TBN	TBN	TBN	TBN	TBN	TBN	TBN
Loop Distribution per 4 Wire Unbundled Copper Sub-Loop, per month		UCS4X	TBN	TBN	TBN	TBN	TBN	TBN	TBN	TBN	TBN	TBN
	NRC - 1st	UCS4X	TBN	TBN	TBN	TBN	TBN	TBN	TBN	TBN	TBN	TBN
	NRC - Add'l	UCS4X	TBN	TBN	TBN	TBN	TBN	TBN	TBN	TBN	TBN	TBN
	NRC - Disconnect Charge - 1st	UCS4X	TBN	TBN	TBN	TBN	TBN	TBN	TBN	TBN	TBN	TBN
	NRC - Disconnect Charge - Add'l	UCS4X	TBN	TBN	TBN	TBN	TBN	TBN	TBN	TBN	TBN	TBN
	NRC - Incremental Charge - Manual Service Order - 1st	SOMAN	TBN	TBN	TBN	TBN	TBN	TBN	TBN	TBN	TBN	TBN
	NRC - Incremental Charge - Manual Service Order - Add'l	SOMAN	TBN	TBN	TBN	TBN	TBN	TBN	TBN	TBN	TBN	TBN
	NRC - Incremental Charge - Manual Service Order - Disconnect	SOMAN	TBN	TBN	TBN	TBN	TBN	TBN	TBN	TBN	TBN	TBN
	NRC - Incremental Charge - Manual Order Coordination - per loop	USBMC	TBN	TBN	TBN	TBN	TBN	TBN	TBN	TBN	TBN	TBN
Sub-Loop-Intrabuilding Network Cable (INC) (a.k.a., riser cable), 2W analog, per m		USBR2	TBN	TBN	\$1.61	TBN	TBN	TBN	TBN	TBN	TBN	TBN
	NRC - 1st	USBR2	TBN	TBN	\$137.03	TBN	TBN	TBN	TBN	TBN	TBN	TBN
	NRC - Add'l	USBR2	TBN	TBN	\$41.59	TBN	TBN	TBN	TBN	TBN	TBN	TBN
	NRC - Disconnect Charge - 1st	USBR2	TBN	TBN	\$115.85	TBN	TBN	TBN	TBN	TBN	TBN	TBN
	NRC - Disconnect Charge - Add'l	USBR2	TBN	TBN	\$19.17	TBN	TBN	TBN	TBN	TBN	TBN	TBN
	NRC - Incremental Charge - Manual Service Order - 1st	SOMAN	TBN	TBN	NA	TBN	TBN	TBN	TBN	TBN	TBN	TBN
	NRC - Incremental Charge - Manual Service Order - Add'l	SOMAN	TBN	TBN	NA	TBN	TBN	TBN	TBN	TBN	TBN	TBN
	NRC - Incremental Charge - Manual Service Order - Disconnect	SOMAN	TBN	TBN	NA	TBN	TBN	TBN	TBN	TBN	TBN	TBN
	NRC - Incremental Charge - Manual Order Coordination - per loop	USBMC	TBN	TBN	\$34.22	TBN	TBN	TBN	TBN	TBN	TBN	TBN
Sub-Loop-Intrabuilding Network Cable (a.k.a.,riser cable), 4W analog, per month		USBR4	TBN	TBN	\$2.96	TBN	TBN	TBN	TBN	TBN	TBN	TBN
	NRC - 1st	USBR4	TBN	TBN	\$176.46	TBN	TBN	TBN	TBN	TBN	TBN	TBN
	NRC - Add'l	USBR4	TBN	TBN	\$55.11	TBN	TBN	TBN	TBN	TBN	TBN	TBN
	NRC - Disconnect Charge - 1st	USBR4	TBN	TBN	\$122.17	TBN	TBN	TBN	TBN	TBN	TBN	TBN
	NRC - Disconnect Charge - Add'l	USBR4	TBN	TBN	\$19.57	TBN	TBN	TBN	TBN	TBN	TBN	TBN
	NRC - Incremental Charge - Manual Service Order - 1st	SOMAN	TBN	TBN	NA	TBN	TBN	TBN	TBN	TBN	TBN	TBN
	NRC - Incremental Charge - Manual Service Order - Add'l	SOMAN	TBN	TBN	NA	TBN	TBN	TBN	TBN	TBN	TBN	TBN
	NRC - Incremental Charge - Manual Service Order - Disconnect	SOMAN	TBN	TBN	NA	TBN	TBN	TBN	TBN	TBN	TBN	TBN
	NRC - Incremental Charge - Manual Order Coordination - per loop	USBMC	TBN	TBN	\$34.22	TBN	TBN	TBN	TBN	TBN	TBN	TBN
SUB-LOOP FEEDER												

BELLSOUTH/LEVEL 3 RATES
NETWORK ELEMENTS
AND OTHER SERVICES

Cross-Box Set-Up													
		NRC - DS0 Set-Up per Cross Box location - CLEC Distribution Facility set-up	USBFW	TBN	TBN	\$421.08	TBN	TBN	TBN	TBN	TBN	TBN	
		NRC - DS0 Set-Up per Cross Box location - per 25 pair panel set-up	USBFX	TBN	TBN	\$67.10	TBN	TBN	TBN	TBN	TBN	TBN	
		NRC - DS1 Set-Up per Cross Box location - CLEC Distribution Facility set-up	USBFY	TBN	TBN	TBN	TBN	TBN	TBN	TBN	TBN	TBN	
		NRC - DS1 Set-Up per Cross Box location - per pair panel set-up	USBFZ	TBN	TBN	TBN	TBN	TBN	TBN	TBN	TBN	TBN	
		2-Wire Analog VG Ground-Start Unbundled Sub-Loop Feeder, per month	USBFA	TBN	TBN	\$8.58	TBN	TBN	TBN	TBN	TBN	TBN	
		NRC - 1st	USBFA	TBN	TBN	\$206.44	TBN	TBN	TBN	TBN	TBN	TBN	
		NRC - Add'l	USBFA	TBN	TBN	\$170.05	TBN	TBN	TBN	TBN	TBN	TBN	
		NRC - Disconnect Charge - 1st	USBFA	TBN	TBN	TBN	TBN	TBN	TBN	TBN	TBN	TBN	
		NRC - Disconnect Charge - Add'l	USBFA	TBN	TBN	TBN	TBN	TBN	TBN	TBN	TBN	TBN	
		NRC - Incremental Charge - Manual Service Order - 1st	SOMAN	TBN	TBN	\$18.94	TBN	TBN	TBN	TBN	TBN	TBN	
		NRC - Incremental Charge - Manual Service Order - Add'l	SOMAN	TBN	TBN	\$8.42	TBN	TBN	TBN	TBN	TBN	TBN	
		NRC - Incremental Charge - Manual Service Order - Disconnect	SOMAN	TBN	TBN	TBN	TBN	TBN	TBN	TBN	TBN	TBN	
		NRC - Incremental Charge - Manual Order Coordination - per loop	TBD	TBN	TBN	\$34.22	TBN	TBN	TBN	TBN	TBN	TBN	
		2-Wire Analog VG Loop-Start Unbundled Sub-Loop Feeder, per month	USBFB	TBN	TBN	\$8.58	TBN	TBN	TBN	TBN	TBN	TBN	
		NRC - 1st	USBFB	TBN	TBN	\$206.44	TBN	TBN	TBN	TBN	TBN	TBN	
		NRC - Add'l	USBFB	TBN	TBN	\$170.05	TBN	TBN	TBN	TBN	TBN	TBN	
		NRC - Disconnect Charge - 1st	USBFB	TBN	TBN	TBN	TBN	TBN	TBN	TBN	TBN	TBN	
		NRC - Disconnect Charge - Add'l	USBFB	TBN	TBN	TBN	TBN	TBN	TBN	TBN	TBN	TBN	
		NRC - Incremental Charge - Manual Service Order - 1st	SOMAN	TBN	TBN	\$18.94	TBN	TBN	TBN	TBN	TBN	TBN	
		NRC - Incremental Charge - Manual Service Order - Add'l	SOMAN	TBN	TBN	\$8.42	TBN	TBN	TBN	TBN	TBN	TBN	
		NRC - Incremental Charge - Manual Service Order - Disconnect	SOMAN	TBN	TBN	TBN	TBN	TBN	TBN	TBN	TBN	TBN	
		NRC - Incremental Charge - Manual Order Coordination - per loop	TBD	TBN	TBN	\$34.22	TBN	TBN	TBN	TBN	TBN	TBN	
		2-Wire Analog VG Reverse Battery Unbundled Sub-Loop Feeder, per month	USBFC	TBN	TBN	\$8.58	TBN	TBN	TBN	TBN	TBN	TBN	
		NRC - 1st	USBFC	TBN	TBN	\$206.44	TBN	TBN	TBN	TBN	TBN	TBN	
		NRC - Add'l	USBFC	TBN	TBN	\$170.05	TBN	TBN	TBN	TBN	TBN	TBN	
		NRC - Disconnect Charge - 1st	USBFC	TBN	TBN	TBN	TBN	TBN	TBN	TBN	TBN	TBN	
		NRC - Disconnect Charge - Add'l	USBFC	TBN	TBN	TBN	TBN	TBN	TBN	TBN	TBN	TBN	
		NRC - Incremental Charge - Manual Service Order - 1st	SOMAN	TBN	TBN	\$18.94	TBN	TBN	TBN	TBN	TBN	TBN	
		NRC - Incremental Charge - Manual Service Order - Add'l	SOMAN	TBN	TBN	\$8.42	TBN	TBN	TBN	TBN	TBN	TBN	
		NRC - Incremental Charge - Manual Service Order - Disconnect	SOMAN	TBN	TBN	TBN	TBN	TBN	TBN	TBN	TBN	TBN	
		NRC - Incremental Charge - Manual Order Coordination - per loop	TBD	TBN	TBN	\$34.22	TBN	TBN	TBN	TBN	TBN	TBN	
		4-Wire Analog VG Ground-Start Unbundled Sub-Loop Feeder, per month	USBFD	TBN	TBN	\$19.91	TBN	TBN	TBN	TBN	TBN	TBN	
		NRC - 1st	USBFD	TBN	TBN	\$243.41	TBN	TBN	TBN	TBN	TBN	TBN	
		NRC - Add'l	USBFD	TBN	TBN	\$81.32	TBN	TBN	TBN	TBN	TBN	TBN	
		NRC - Disconnect Charge - 1st	USBFD	TBN	TBN	\$134.77	TBN	TBN	TBN	TBN	TBN	TBN	
		NRC - Disconnect Charge - Add'l	USBFD	TBN	TBN	\$33.93	TBN	TBN	TBN	TBN	TBN	TBN	
		NRC - Incremental Charge - Manual Service Order - 1st	SOMAN	TBN	TBN	NA	TBN	TBN	TBN	TBN	TBN	TBN	
		NRC - Incremental Charge - Manual Service Order - Add'l	SOMAN	TBN	TBN	NA	TBN	TBN	TBN	TBN	TBN	TBN	
		NRC - Incremental Charge - Manual Service Order - Disconnect	SOMAN	TBN	TBN	NA	TBN	TBN	TBN	TBN	TBN	TBN	
		NRC - Incremental Charge - Manual Order Coordination - per loop	TBD	TBN	TBN	\$34.22	TBN	TBN	TBN	TBN	TBN	TBN	
		4-Wire Analog VG Loop-Start Unbundled Sub-Loop Feeder, per month	USBFE	TBN	TBN	\$19.91	TBN	TBN	TBN	TBN	TBN	TBN	
		NRC - 1st	USBFE	TBN	TBN	\$243.41	TBN	TBN	TBN	TBN	TBN	TBN	
		NRC - Add'l	USBFE	TBN	TBN	\$81.32	TBN	TBN	TBN	TBN	TBN	TBN	
		NRC - Disconnect Charge - 1st	USBFE	TBN	TBN	\$134.77	TBN	TBN	TBN	TBN	TBN	TBN	
		NRC - Disconnect Charge - Add'l	USBFE	TBN	TBN	\$33.93	TBN	TBN	TBN	TBN	TBN	TBN	
		NRC - Incremental Charge - Manual Service Order - 1st	SOMAN	TBN	TBN	NA	TBN	TBN	TBN	TBN	TBN	TBN	
		NRC - Incremental Charge - Manual Service Order - Add'l	SOMAN	TBN	TBN	NA	TBN	TBN	TBN	TBN	TBN	TBN	
		NRC - Incremental Charge - Manual Service Order - Disconnect	SOMAN	TBN	TBN	NA	TBN	TBN	TBN	TBN	TBN	TBN	

BELLSOUTH/LEVEL 3 RATES
NETWORK ELEMENTS
AND OTHER SERVICES

	NRC - Incremental Charge - Manual Order Coordination - per loop	TBD	TBN	TBN	\$34.22	TBN	TBN	TBN	TBN	TBN	TBN	
	2-Wire ISDN Unbundled Sub-Loop Feeder, per month	USBFF	TBN	TBN	\$17.73	TBN	TBN	TBN	TBN	TBN	TBN	
	NRC - 1st	USBFF	TBN	TBN	\$208.50	TBN	TBN	TBN	TBN	TBN	TBN	
	NRC - Add'l	USBFF	TBN	TBN	\$62.31	TBN	TBN	TBN	TBN	TBN	TBN	
	NRC - Disconnect Charge - 1st	USBFF	TBN	TBN	\$119.68	TBN	TBN	TBN	TBN	TBN	TBN	
	NRC - Disconnect Charge - Add'l	USBFF	TBN	TBN	\$29.58	TBN	TBN	TBN	TBN	TBN	TBN	
	NRC - Incremental Charge - Manual Service Order - 1st	SOMAN	TBN	TBN	NA	TBN	TBN	TBN	TBN	TBN	TBN	
	NRC - Incremental Charge - Manual Service Order - Add'l	SOMAN	TBN	TBN	NA	TBN	TBN	TBN	TBN	TBN	TBN	
	NRC - Incremental Charge - Manual Service Order - Disconnect	SOMAN	TBN	TBN	NA	TBN	TBN	TBN	TBN	TBN	TBN	
	NRC - Incremental Charge - Manual Order Coordination - per loop	TBD	TBN	TBN	\$34.22	TBN	TBN	TBN	TBN	TBN	TBN	
	4-Wire DSI Unbundled Sub-Loop Feeder, per month	USBFG	TBN	TBN	TBN	TBN	TBN	TBN	TBN	TBN	TBN	
	NRC - 1st	USBFG	TBN	TBN	TBN	TBN	TBN	TBN	TBN	TBN	TBN	
	NRC - Add'l	USBFG	TBN	TBN	TBN	TBN	TBN	TBN	TBN	TBN	TBN	
	NRC - Disconnect Charge - 1st	USBFG	TBN	TBN	TBN	TBN	TBN	TBN	TBN	TBN	TBN	
	NRC - Disconnect Charge - Add'l	USBFG	TBN	TBN	TBN	TBN	TBN	TBN	TBN	TBN	TBN	
	NRC - Incremental Charge - Manual Service Order - 1st	SOMAN	TBN	TBN	TBN	TBN	TBN	TBN	TBN	TBN	TBN	
	NRC - Incremental Charge - Manual Service Order - Add'l	SOMAN	TBN	TBN	TBN	TBN	TBN	TBN	TBN	TBN	TBN	
	NRC - Incremental Charge - Manual Service Order - Disconnect	SOMAN	TBN	TBN	TBN	TBN	TBN	TBN	TBN	TBN	TBN	
	NRC - Incremental Charge - Manual Order Coordination - per loop	TBD	TBN	TBN	TBN	TBN	TBN	TBN	TBN	TBN	TBN	
	2-Wire Copper Unbundled Sub-Loop Feeder, per month	USBFH	TBN	TBN	TBN	TBN	TBN	TBN	TBN	TBN	TBN	
	NRC - 1st	USBFH	TBN	TBN	TBN	TBN	TBN	TBN	TBN	TBN	TBN	
	NRC - Add'l	USBFH	TBN	TBN	TBN	TBN	TBN	TBN	TBN	TBN	TBN	
	NRC - Disconnect Charge - 1st	USBFH	TBN	TBN	TBN	TBN	TBN	TBN	TBN	TBN	TBN	
	NRC - Disconnect Charge - Add'l	USBFH	TBN	TBN	TBN	TBN	TBN	TBN	TBN	TBN	TBN	
	NRC - Incremental Charge - Manual Service Order - 1st	SOMAN	TBN	TBN	TBN	TBN	TBN	TBN	TBN	TBN	TBN	
	NRC - Incremental Charge - Manual Service Order - Add'l	SOMAN	TBN	TBN	TBN	TBN	TBN	TBN	TBN	TBN	TBN	
	NRC - Incremental Charge - Manual Service Order - Disconnect	SOMAN	TBN	TBN	TBN	TBN	TBN	TBN	TBN	TBN	TBN	
	NRC - Incremental Charge - Manual Order Coordination - per loop	TBD	TBN	TBN	TBN	TBN	TBN	TBN	TBN	TBN	TBN	
	4-Wire Copper Unbundled Sub-Loop Feeder, per month	USBFJ	TBN	TBN	TBN	TBN	TBN	TBN	TBN	TBN	TBN	
	NRC - 1st	USBFJ	TBN	TBN	TBN	TBN	TBN	TBN	TBN	TBN	TBN	
	NRC - Add'l	USBFJ	TBN	TBN	TBN	TBN	TBN	TBN	TBN	TBN	TBN	
	NRC - Disconnect Charge - 1st	USBFJ	TBN	TBN	TBN	TBN	TBN	TBN	TBN	TBN	TBN	
	NRC - Disconnect Charge - Add'l	USBFJ	TBN	TBN	TBN	TBN	TBN	TBN	TBN	TBN	TBN	
	NRC - Incremental Charge - Manual Service Order - 1st	SOMAN	TBN	TBN	TBN	TBN	TBN	TBN	TBN	TBN	TBN	
	NRC - Incremental Charge - Manual Service Order - Add'l	SOMAN	TBN	TBN	TBN	TBN	TBN	TBN	TBN	TBN	TBN	
	NRC - Incremental Charge - Manual Service Order - Disconnect	SOMAN	TBN	TBN	TBN	TBN	TBN	TBN	TBN	TBN	TBN	
	NRC - Incremental Charge - Manual Order Coordination - per loop	TBD	TBN	TBN	TBN	TBN	TBN	TBN	TBN	TBN	TBN	
	4-Wire 2.4 KBPS Digital Unbundled Sub-Loop Feeder, per month	USBFK	TBN	TBN	TBN	TBN	TBN	TBN	TBN	TBN	TBN	
	NRC - 1st	USBFK	TBN	TBN	TBN	TBN	TBN	TBN	TBN	TBN	TBN	
	NRC - Add'l	USBFK	TBN	TBN	TBN	TBN	TBN	TBN	TBN	TBN	TBN	
	NRC - Disconnect Charge - 1st	USBFK	TBN	TBN	TBN	TBN	TBN	TBN	TBN	TBN	TBN	
	NRC - Disconnect Charge - Add'l	USBFK	TBN	TBN	TBN	TBN	TBN	TBN	TBN	TBN	TBN	
	NRC - Incremental Charge - Manual Service Order - 1st	SOMAN	TBN	TBN	TBN	TBN	TBN	TBN	TBN	TBN	TBN	
	NRC - Incremental Charge - Manual Service Order - Add'l	SOMAN	TBN	TBN	TBN	TBN	TBN	TBN	TBN	TBN	TBN	
	NRC - Incremental Charge - Manual Service Order - Disconnect	SOMAN	TBN	TBN	TBN	TBN	TBN	TBN	TBN	TBN	TBN	
	NRC - Incremental Charge - Manual Order Coordination - per loop	TBD	TBN	TBN	TBN	TBN	TBN	TBN	TBN	TBN	TBN	
	4-Wire 4.8 KBPS Digital Unbundled Sub-Loop Feeder, per month	USBFL	TBN	TBN	TBN	TBN	TBN	TBN	TBN	TBN	TBN	
	NRC - 1st	USBFL	TBN	TBN	TBN	TBN	TBN	TBN	TBN	TBN	TBN	
	NRC - Add'l	USBFL	TBN	TBN	TBN	TBN	TBN	TBN	TBN	TBN	TBN	
	NRC - Disconnect Charge - 1st	USBFL	TBN	TBN	TBN	TBN	TBN	TBN	TBN	TBN	TBN	

BELLSOUTH/LEVEL 3 RATES
NETWORK ELEMENTS
AND OTHER SERVICES

	NRC - Disconnect Charge - Add'l	USBFL	TBN	TBN	TBN	TBN	TBN	TBN	TBN	TBN	TBN	TBN	
	NRC - Incremental Charge - Manual Service Order - 1st	SOMAN	TBN	TBN	TBN	TBN	TBN	TBN	TBN	TBN	TBN	TBN	
	NRC - Incremental Charge - Manual Service Order - Add'l	SOMAN	TBN	TBN	TBN	TBN	TBN	TBN	TBN	TBN	TBN	TBN	
	NRC - Incremental Charge - Manual Service Order - Disconnect	SOMAN	TBN	TBN	TBN	TBN	TBN	TBN	TBN	TBN	TBN	TBN	
	NRC - Incremental Charge - Manual Order Coordination - per loop	TBD	TBN	TBN	TBN	TBN	TBN	TBN	TBN	TBN	TBN	TBN	
	4-Wire 9.6 KBPS Digital Unbundled Sub-Loop Feeder, per month	USBFM	TBN	TBN	TBN	TBN	TBN	TBN	TBN	TBN	TBN	TBN	
	NRC - 1st	USBFM	TBN	TBN	TBN	TBN	TBN	TBN	TBN	TBN	TBN	TBN	
	NRC - Add'l	USBFM	TBN	TBN	TBN	TBN	TBN	TBN	TBN	TBN	TBN	TBN	
	NRC - Disconnect Charge - 1st	USBFM	TBN	TBN	TBN	TBN	TBN	TBN	TBN	TBN	TBN	TBN	
	NRC - Disconnect Charge - Add'l	USBFM	TBN	TBN	TBN	TBN	TBN	TBN	TBN	TBN	TBN	TBN	
	NRC - Incremental Charge - Manual Service Order - 1st	SOMAN	TBN	TBN	TBN	TBN	TBN	TBN	TBN	TBN	TBN	TBN	
	NRC - Incremental Charge - Manual Service Order - Add'l	SOMAN	TBN	TBN	TBN	TBN	TBN	TBN	TBN	TBN	TBN	TBN	
	NRC - Incremental Charge - Manual Service Order - Disconnect	SOMAN	TBN	TBN	TBN	TBN	TBN	TBN	TBN	TBN	TBN	TBN	
	NRC - Incremental Charge - Manual Order Coordination - per loop	TBD	TBN	TBN	TBN	TBN	TBN	TBN	TBN	TBN	TBN	TBN	
	4-Wire 19.2 KBPS Digital Unbundled Sub-Loop Feeder, per month	USBFN	TBN	TBN	TBN	TBN	TBN	TBN	TBN	TBN	TBN	TBN	
	NRC - 1st	USBFN	TBN	TBN	TBN	TBN	TBN	TBN	TBN	TBN	TBN	TBN	
	NRC - Add'l	USBFN	TBN	TBN	TBN	TBN	TBN	TBN	TBN	TBN	TBN	TBN	
	NRC - Disconnect Charge - 1st	USBFN	TBN	TBN	TBN	TBN	TBN	TBN	TBN	TBN	TBN	TBN	
	NRC - Disconnect Charge - Add'l	USBFN	TBN	TBN	TBN	TBN	TBN	TBN	TBN	TBN	TBN	TBN	
	NRC - Incremental Charge - Manual Service Order - 1st	SOMAN	TBN	TBN	TBN	TBN	TBN	TBN	TBN	TBN	TBN	TBN	
	NRC - Incremental Charge - Manual Service Order - Add'l	SOMAN	TBN	TBN	TBN	TBN	TBN	TBN	TBN	TBN	TBN	TBN	
	NRC - Incremental Charge - Manual Service Order - Disconnect	SOMAN	TBN	TBN	TBN	TBN	TBN	TBN	TBN	TBN	TBN	TBN	
	NRC - Incremental Charge - Manual Order Coordination - per loop	TBD	TBN	TBN	TBN	TBN	TBN	TBN	TBN	TBN	TBN	TBN	
	4-Wire 56 KBPS Digital Unbundled Sub-Loop Feeder, per month	USBFO	TBN	TBN	TBN	TBN	TBN	TBN	TBN	TBN	TBN	TBN	
	NRC - 1st	USBFO	TBN	TBN	TBN	TBN	TBN	TBN	TBN	TBN	TBN	TBN	
	NRC - Add'l	USBFO	TBN	TBN	TBN	TBN	TBN	TBN	TBN	TBN	TBN	TBN	
	NRC - Disconnect Charge - 1st	USBFO	TBN	TBN	TBN	TBN	TBN	TBN	TBN	TBN	TBN	TBN	
	NRC - Disconnect Charge - Add'l	USBFO	TBN	TBN	TBN	TBN	TBN	TBN	TBN	TBN	TBN	TBN	
	NRC - Incremental Charge - Manual Service Order - 1st	SOMAN	TBN	TBN	TBN	TBN	TBN	TBN	TBN	TBN	TBN	TBN	
	NRC - Incremental Charge - Manual Service Order - Add'l	SOMAN	TBN	TBN	TBN	TBN	TBN	TBN	TBN	TBN	TBN	TBN	
	NRC - Incremental Charge - Manual Service Order - Disconnect	SOMAN	TBN	TBN	TBN	TBN	TBN	TBN	TBN	TBN	TBN	TBN	
	NRC - Incremental Charge - Manual Order Coordination - per loop	TBD	TBN	TBN	TBN	TBN	TBN	TBN	TBN	TBN	TBN	TBN	
	4-Wire 64 KBPS Digital Unbundled Sub-Loop Feeder, per month	USBFP	TBN	TBN	TBN	TBN	TBN	TBN	TBN	TBN	TBN	TBN	
	NRC - 1st	USBFP	TBN	TBN	TBN	TBN	TBN	TBN	TBN	TBN	TBN	TBN	
	NRC - Add'l	USBFP	TBN	TBN	TBN	TBN	TBN	TBN	TBN	TBN	TBN	TBN	
	NRC - Disconnect Charge - 1st	USBFP	TBN	TBN	TBN	TBN	TBN	TBN	TBN	TBN	TBN	TBN	
	NRC - Disconnect Charge - Add'l	USBFP	TBN	TBN	TBN	TBN	TBN	TBN	TBN	TBN	TBN	TBN	
	NRC - Incremental Charge - Manual Service Order - 1st	SOMAN	TBN	TBN	TBN	TBN	TBN	TBN	TBN	TBN	TBN	TBN	
	NRC - Incremental Charge - Manual Service Order - Add'l	SOMAN	TBN	TBN	TBN	TBN	TBN	TBN	TBN	TBN	TBN	TBN	
	NRC - Incremental Charge - Manual Service Order - Disconnect	SOMAN	TBN	TBN	TBN	TBN	TBN	TBN	TBN	TBN	TBN	TBN	
	NRC - Incremental Charge - Manual Order Coordination - per loop	TBD	TBN	TBN	TBN	TBN	TBN	TBN	TBN	TBN	TBN	TBN	
	Unbundled Sub-Loop Modification												
	NRC - Load Coil/Equipment Removal per 2 Wire pair	ULM2X	TBN	TBN	TBN	TBN	TBN	TBN	TBN	TBN	TBN	TBN	
	NRC - Load Coil/Equipment Removal per 4 Wire pair	ULM4X	TBN	TBN	TBN	TBN	TBN	TBN	TBN	TBN	TBN	TBN	
	NRC - Bridge Tap Removal per pair unloaded	ULMBT	TBN	TBN	TBN	TBN	TBN	TBN	TBN	TBN	TBN	TBN	
	Unbundled Network Terminating Wire, per pair, per month	UENPP	TBN	TBN	\$1.37	TBN	TBN	TBN	TBN	TBN	TBN	TBN	
	NRC - UNTW Pair, per pair	UENPP	TBN	TBN	\$2.48	TBN	TBN	TBN	TBN	TBN	TBN	TBN	
	NRC - Disconnect Charge, per pair	UENPP	TBN	TBN	\$1.74	TBN	TBN	TBN	TBN	TBN	TBN	TBN	
	NRC - Incremental Charge - Manual Service Order	SOMAN	TBN	TBN	NA	TBN	TBN	TBN	TBN	TBN	TBN	TBN	
	NRC - Incremental Charge - Manual Service Order - Disconnect	SOMAN	TBN	TBN	NA	TBN	TBN	TBN	TBN	TBN	TBN	TBN	

BELLSOUTH/LEVEL 3 RATES
NETWORK ELEMENTS
AND OTHER SERVICES

	Sub-Loop Concentration - Channelization Sys (Outside CO)												
	NRC - Incremental Charge - Manual Service Order - 1st	SOMAN	\$27.37	TBD	\$18.94	TBD	TBD	TBD	TBD	TBD	TBD	TBD	TBD
	NRC - Incremental Charge - Manual Service Order - Add'l	SOMAN	\$12.97	TBD	\$8.42	TBD	TBD	TBD	TBD	TBD	TBD	TBD	TBD
	TR008 - System A (96 channel capacity - channels 1-96), per month	UCT8A	TBN	\$792.49	\$724.79	\$757.00	TBN	TBN	TBN	TBN	TBN	\$683.78	
	NRC - 1st	UCT8A	TBN	\$640.93	\$632.36	\$633.94	TBN	TBN	TBN	TBN	TBN	\$634.31	
	NRC - Add'l	UCT8A	TBN	\$315.03	\$310.82	\$311.60	TBN	TBN	TBN	TBN	TBN	\$311.78	
	TR008 - System B (96 channel capacity - channels 97-192), per month	UCT8B	TBN	\$155.32	\$92.91	\$95.60	TBN	TBN	TBN	TBN	TBN	\$102.12	
	NRC - 1st	UCT8B	TBN	\$640.93	\$632.36	\$633.94	TBN	TBN	TBN	TBN	TBN	\$634.31	
	NRC - Add'l	UCT8B	TBN	\$315.03	\$310.82	\$311.60	TBN	TBN	TBN	TBN	TBN	\$311.78	
	TR303 - System A (96 channel capacity - channels 1-96), per month	UCT3A	TBN	\$835.72	\$764.42	\$799.95	TBN	TBN	TBN	TBN	TBN	\$726.87	
	NRC - 1st	UCT3A	TBN	\$640.93	\$632.36	\$633.94	TBN	TBN	TBN	TBN	TBN	\$634.31	
	NRC - Add'l	UCT3A	TBN	\$315.03	\$310.82	\$311.60	TBN	TBN	TBN	TBN	TBN	\$311.78	
	TR303 - System B (96 channel capacity - channels 97-192), per month	UCT3B	TBN	\$198.55	\$132.54	\$138.55	TBN	TBN	TBN	TBN	TBN	\$145.21	
	NRC - 1st	UCT3B	TBN	\$640.93	\$632.36	\$633.94	TBN	TBN	TBN	TBN	TBN	\$634.31	
	NRC - Add'l	UCT3B	TBN	\$315.03	\$310.82	\$311.60	TBN	TBN	TBN	TBN	TBN	\$311.78	
	DS1 Feeder Interface, per month	UCTFS	TBN	\$78.43	\$72.12	\$77.02	TBN	TBN	TBN	TBN	TBN	\$76.73	
	NRC 1st	UCTFS	TBN	\$422.74	\$425.74	\$418.13	TBN	TBN	TBN	TBN	TBN	\$418.37	
	NRC Add'l	UCTFS	TBN	\$200.74	\$198.06	\$198.56	TBN	TBN	TBN	TBN	TBN	\$198.67	
	Channel Interface - 2 Wire Voice - Loop Start , per month	TBD	TBN	\$2.62	\$2.38	\$2.68	TBN	TBN	TBN	TBN	TBN	\$2.61	
	NRC 1st	TBD	TBN	\$42.39	\$41.82	\$41.92	TBN	TBN	TBN	TBN	TBN	\$41.95	
	NRC Add'l	TBD	TBN	\$42.15	\$41.58	\$41.69	TBN	TBN	TBN	TBN	TBN	\$41.71	
	Channel Interface - 2 Wire ISDN, per month	ULCC1	TBN	\$10.49	\$9.53	\$10.72	TBN	TBN	TBN	TBN	TBN	\$10.43	
	NRC 1st	ULCC1	TBN	\$42.39	\$41.82	\$41.92	TBN	TBN	TBN	TBN	TBN	\$41.95	
	NRC Add'l	ULCC1	TBN	\$42.15	\$41.58	\$41.69	TBN	TBN	TBN	TBN	TBN	\$41.71	
	Channel Interface - 2 Wire Voice - Ground Start or Reverse Battery, per month	TBD	TBN	\$15.59	\$14.17	\$15.94	TBN	TBN	TBN	TBN	TBN	\$15.51	
	NRC 1st	TBD	TBN	\$42.39	\$41.82	\$41.92	TBN	TBN	TBN	TBN	TBN	\$41.95	
	NRC Add'l	TBD	TBN	\$42.15	\$41.58	\$41.69	TBN	TBN	TBN	TBN	TBN	\$41.71	
	Channel Interface - 4 Wire Voice, per month	ULCC4	TBN	\$9.30	\$8.45	\$9.50	TBN	TBN	TBN	TBN	TBN	\$9.26	
	NRC 1st	ULCC4	TBN	\$42.39	\$41.82	\$41.92	TBN	TBN	TBN	TBN	TBN	\$41.95	
	NRC Add'l	ULCC4	TBN	\$42.15	\$41.58	\$41.69	TBN	TBN	TBN	TBN	TBN	\$41.71	
	Test Circuit, per month	UCTTC	TBN	\$45.46	\$41.30	\$46.44	TBN	TBN	TBN	TBN	TBN	\$45.22	
	NRC 1st	UCTTC	TBN	\$42.39	\$41.82	\$41.92	TBN	TBN	TBN	TBN	TBN	\$41.95	
	NRC Add'l	UCTTC	TBN	\$42.15	\$41.58	\$41.69	TBN	TBN	TBN	TBN	TBN	\$41.71	
	Channel Interface - Digital 56Kbps, per month	ULCC5	TBN	\$13.78	\$12.51	\$14.08	TBN	TBN	TBN	TBN	TBN	\$13.71	
	NRC 1st	ULCC5	TBN	\$42.39	\$41.82	\$41.92	TBN	TBN	TBN	TBN	TBN	\$41.95	
	NRC Add'l	ULCC5	TBN	\$42.15	\$41.58	\$41.69	TBN	TBN	TBN	TBN	TBN	\$41.71	
	Channel Interface - Digital 64Kbps, per month	ULCC6	TBN	\$13.78	\$12.51	\$14.08	TBN	TBN	TBN	TBN	TBN	\$13.71	
	NRC 1st	ULCC6	TBN	\$42.39	\$41.82	\$41.92	TBN	TBN	TBN	TBN	TBN	\$41.95	
	NRC Add'l	ULCC6	TBN	\$42.15	\$41.58	\$41.69	TBN	TBN	TBN	TBN	TBN	\$41.71	
	Loop Concentration System (Inside C.O.)												
	NRC - Incremental Charge - Manual Service Order - 1st	SOMAN	\$27.37	TBD	\$18.94	TBD	\$18.14	\$25.52	TBD	\$44.06	TBD		
	NRC - Incremental Charge - Manual Service Order - Add'l	SOMAN	\$12.97	TBD	\$8.42	TBD	\$8.06	\$11.34	TBD	\$13.55	TBD		
	TR008 -System A (96 channel capacity - channels 1-96), per month	UCT8A	\$327.44	\$400.33	\$316.63	\$394.00	\$308.74	\$454.79	\$375.96	\$399.21	\$380.06		
	NRC - 1st	UCT8A	\$1,115.10	\$1,128.75	\$1,111.95	\$1,116.15	\$1,117.20	\$1,115.10	\$1,113.00	\$1,119.30	\$1,114.05		
	NRC - Add'l	UCT8A	NA	NA	NA	NA	NA	NA	NA	NA	NA		
	TR008 -System B (96 channel capacity - channels 97-192), per month	UCT8B	\$67.41	\$70.48	\$65.27	\$72.21	\$76.58	\$73.30	\$65.98	\$71.91	\$68.71		
	NRC - 1st	UCT8B	\$464.57	\$470.41	\$463.37	\$465.11	\$465.64	\$464.71	\$463.74	\$466.38	\$464.21		
	NRC - Add'l	UCT8B	NA	NA	NA	NA	NA	NA	NA	NA	NA		
	TR303 - System A (96 channel capacity - channels 1-96), per month	UCT3A	\$375.18	\$450.24	\$362.87	\$445.14	\$385.97	\$506.70	\$422.68	\$450.13	\$428.73		
	NRC - 1st	UCT3A	\$1,115.10	\$1,128.75	\$1,111.95	\$1,116.15	\$1,117.20	\$1,115.10	\$1,113.00	\$1,119.30	\$1,114.05		
	NRC - Add'l	UCT3A	NA	NA	NA	NA	NA	NA	NA	NA	NA		
	TR303 - System B (96 channel capacity - channels 97-192), per month	UCT3B	\$111.30	\$118.76	\$110.02	\$121.45	\$129.05	\$123.52	\$111.17	\$121.16	\$115.79		
	NRC - 1st	UCT3B	\$464.57	\$470.41	\$463.37	\$465.11	\$465.64	\$464.71	\$463.74	\$466.38	\$464.21		
	NRC - Add'l	UCT3B	NA	NA	NA	NA	NA	NA	NA	NA	NA		
	DS1 Interface, per month	UCTCO	\$6.42	\$6.47	\$6.15	\$403.20	\$7.35	\$6.99	\$6.27	\$6.79	\$6.49		

BELLSOUTH/LEVEL 3 RATES
NETWORK ELEMENTS
AND OTHER SERVICES

	NRC 1st	UCTCO	\$367.70	\$372.32	\$366.72	\$132.18	\$368.54	\$367.80	\$367.04	\$369.13	\$367.41
	NRC Add'l	UCTCO	\$132.03	\$133.69	\$130.63	\$132.18	\$132.33	\$132.07	\$131.79	\$132.54	\$131.92
	Channel Interface - 2 Wire Voice - Loop Start , per month	TBD	\$2.55	\$2.66	\$2.44	\$2.79	\$2.91	\$2.77	\$0.89	\$2.69	\$2.58
	NRC 1st	TBD	\$35.77	\$36.23	\$35.68	\$35.82	\$35.86	\$35.78	\$35.73	\$35.91	\$35.74
	NRC Add'l	TBD	\$35.55	\$36.02	\$35.48	\$35.62	\$35.66	\$35.37	\$35.49	\$35.71	\$35.54
	Channel Interface - 2 Wire ISDN, per month	ULCC1	\$10.19	\$10.67	\$9.76	\$11.18	\$11.66	\$11.10	\$9.95	\$10.76	\$10.30
	NRC 1st	ULCC1	\$35.77	\$36.23	\$35.68	\$35.82	\$35.86	\$35.78	\$35.71	\$35.91	\$35.74
	NRC Add'l	ULCC1	\$35.55	\$36.02	\$35.48	\$35.62	\$35.66	\$35.37	\$35.51	\$35.71	\$35.54
	Channel Interface - 2 Wire Voice - Ground Start or Reverse Battery, per month	TBD	\$15.15	\$15.85	\$14.51	\$16.62	\$17.33	\$16.46	\$14.80	\$16.01	\$15.32
	NRC 1st	TBD	\$35.77	\$36.23	\$35.68	\$35.82	\$35.86	\$35.78	\$35.71	\$35.91	\$35.74
	NRC Add'l	TBD	\$35.55	\$36.02	\$35.48	\$35.62	\$35.66	\$35.37	\$35.51	\$35.71	\$35.54
	Channel Interface - 4 Wire Voice, per month	ULCC4	\$9.04	\$9.44	\$8.65	\$9.91	\$10.34	\$9.83	\$8.82	\$9.55	\$9.13
	NRC 1st	ULCC4	\$35.77	\$36.23	\$35.68	\$35.82	\$35.86	\$35.78	\$35.71	\$35.91	\$35.74
	NRC Add'l	ULCC4	\$35.55	\$36.02	\$35.48	\$35.62	\$35.66	\$35.37	\$35.51	\$35.71	\$35.54
	Test Circuit, per month	UCTTC	\$44.16	\$46.14	\$42.30	\$48.43	\$50.53	\$47.85	\$43.13	\$46.66	\$44.65
	NRC 1st	UCTTC	\$35.77	\$36.23	\$35.68	\$35.82	\$35.86	\$35.78	\$35.71	\$35.91	\$35.74
	NRC Add'l	UCTTC	\$35.55	\$36.02	\$35.48	\$35.62	\$35.66	\$35.37	\$35.51	\$35.71	\$35.54
	Channel Interface - Digital 56Kbps, per month	ULCC5	TBN	TBN	TBN	TBN	TBN	TBN	TBN	TBN	TBN
	NRC 1st	ULCC5	TBN	TBN	TBN	TBN	TBN	TBN	TBN	TBN	TBN
	NRC Add'l	ULCC5	TBN	TBN	TBN	TBN	TBN	TBN	TBN	TBN	TBN
	Channel Interface - Digital 64Kbps, per month	ULCC6	TBN	TBN	TBN	TBN	TBN	TBN	TBN	TBN	TBN
	NRC 1st	ULCC6	TBN	TBN	TBN	TBN	TBN	TBN	TBN	TBN	TBN
	NRC Add'l	ULCC6	TBN	TBN	TBN	TBN	TBN	TBN	TBN	TBN	TBN
	LINE SHARING										
	System Splitter - 96 Line Capacity										
	RC - Per month	USLDA	\$100.00	\$100.00	\$100.00	\$100.00	\$100.00	\$100.00	\$100.00	\$100.00	\$100.00
	NRC - 1st	USLDA	\$150.00	\$150.00	\$150.00	\$300.00	\$150.00	\$300.00	\$300.00	\$300.00	\$150.00
	NRC - Addl	USLDA	\$0.00	\$0.00	\$0.00	\$0.00	\$0.00	\$0.00	\$0.00	\$0.00	\$0.00
	NRC - Disconnect	USLDA	\$150.00	\$150.00	\$150.00	NA	\$150.00	NA	NA	NA	\$150.00
	System Splitter - 24 Line Capacity										
	RC - Per month	USLDB	\$25.00	\$25.00	\$25.00	\$25.00	\$25.00	\$25.00	\$25.00	\$25.00	\$25.00
	NRC - 1st	USLDB	\$150.00	\$150.00	\$150.00	\$300.00	\$150.00	\$300.00	\$300.00	\$300.00	\$150.00
	NRC - Addl	USLDB	\$0.00	\$0.00	\$0.00	\$0.00	\$0.00	\$0.00	\$0.00	\$0.00	\$0.00
	NRC - Disconnect	USLDB	\$150.00	\$150.00	\$150.00	NA	\$150.00	NA	NA	NA	\$150.00
	Loop Capacity, Line Activation Per Occurrence										
	RC - Per Month	USLDC	\$6.00	\$6.00	\$6.00	\$6.00	\$6.00	\$6.00	\$6.00	\$6.00	\$6.00
	NRC - 1st	USLDC	\$40.00	\$40.00	\$40.00	\$40.00	\$40.00	\$40.00	\$40.00	\$40.00	\$40.00
	NRC - Addl	USLDC	\$22.00	\$22.00	\$22.00	\$22.00	\$22.00	\$22.00	\$22.00	\$22.00	\$22.00
	Subsequent Activity - Per Occurrence										
	NRC - 1st	ULSDS	\$30.00	\$30.00	\$30.00	\$30.00	\$30.00	\$30.00	\$30.00	\$30.00	\$30.00
	NRC - Addl	ULSDS	\$15.00	\$15.00	\$15.00	\$15.00	\$15.00	\$15.00	\$15.00	\$15.00	\$15.00
	* Rates subject to true-up										

BELLSOUTH/LEVEL 3 RATES
NETWORK ELEMENTS
AND OTHER SERVICES

DESCRIPTION	USOC	AL	FL	GA	KY	LA	MS	NC	SC	TN
LOCAL EXCHANGE SWITCHING (PORTS)										
2-Wire Analog Line Port (Res., Bus.), per month										
2- wire voice unbundled port - residence	UEPRL	\$2.07	2.00 - Note 1	1.85 - Note 1	2.61 - Note 1	\$2.20	\$2.11	\$2.19	\$2.35	1.90 - Note 1
2-wire voice unbundled port with caller ID - residence	UEPRC	\$2.07	\$2.00	\$1.85	\$2.61	\$2.20	\$2.11	\$2.00	\$2.35	\$1.90
2-wire voice unbundled port outgoing only - residence	UEPRO	\$2.07	\$2.00	\$1.85	\$2.61	\$2.20	\$2.11	\$2.00	\$2.35	\$1.90
2-wire voice unbundled area plus port with caller ID - residence	UEPRM	\$2.07	\$2.00	\$1.85	\$2.61	\$2.20	\$2.11	\$2.00	\$2.35	\$1.90
2-wire voice unbundled Florida area calling with caller ID - residence	UEPAF	NA	\$2.00	NA	NA	NA	NA	NA	NA	NA
2-wire voice unbundled Louisiana Area Plus with caller ID - residence (RUL)	UEPAG	NA	NA	NA	NA	\$2.20	NA	NA	NA	NA
2-wire voice unbundled Louisiana Area Plus with caller ID - residence (AC7)	UEPAH	NA	NA	NA	NA	\$2.20	NA	NA	NA	NA
2-wire voice unbundled South Carolina Area Calling port with Caller ID - residence (LW8)	UEPAJ	NA	NA	NA	NA	NA	NA	NA	\$2.35	NA
2-wire voice unbundled Tennessee Area Calling port with Caller ID - residence (F2R)	UEPAK	NA	NA	NA	NA	NA	NA	NA	NA	\$1.90
2-wire voice unbundled Tennessee Area Calling port with Caller ID - residence (TACER)	UEPAL	NA	NA	NA	NA	NA	NA	NA	NA	\$1.90
2-wire voice unbundled Tennessee Area Calling port with Caller ID - residence (TACSR)	UEPAM	NA	NA	NA	NA	NA	NA	NA	NA	\$1.90
2-wire voice unbundled Tennessee Area Calling port with Caller ID - residence (1MF2X)	UEPAN	NA	NA	NA	NA	NA	NA	NA	NA	\$1.90
2-wire voice unbundled Tennessee Area Calling port with Caller ID - residence (2MR)	UEPAO	NA	NA	NA	NA	NA	NA	NA	NA	\$1.90
2-wire voice unbundled res, low usage line port with Caller ID (LUM)	UEPAP	\$2.07	\$2.00	\$1.85	\$2.61	\$2.20	\$2.11	\$2.00	\$2.35	\$1.90
LOCAL NUMBER PORTABILITY (REQUIRES ONE PER PORT)										
LNPCX										
2-wire voice unbundled port without Caller ID	UEPBL	\$2.07	\$2.00	\$1.85	\$2.61	\$2.20	\$2.11	\$2.00	\$2.35	\$1.90
2-wire voice unbundled port with unbundled port with Caller+E484 ID	UEPBC	\$2.07	\$2.00	\$1.85	\$2.61	\$2.20	\$2.11	\$2.00	\$2.35	\$1.90
2-wire voice unbundled outgoing only port	UEPBO	\$2.07	\$2.00	\$1.85	\$2.61	\$2.20	\$2.11	\$2.00	\$2.35	\$1.90
2-wire voice unbundled area plus port with Caller ID	UEPBM	\$2.07	\$2.00	\$1.85	\$2.61	\$2.20	\$2.11	\$2.00	\$2.35	\$1.90
2-wire voice unbundled incoming only port with Caller ID	UEPB1	\$2.07	\$2.00	\$1.85	\$2.61	\$2.20	\$2.11	\$2.00	\$2.35	\$1.90
2-wire voice unbundled LA Bus Area Calling Port with Caller ID (BUC)	UEPAA	NA	NA	NA	NA	\$2.20	NA	NA	NA	NA
2-wire voice unbundled SC Bus Area Calling Port with Caller ID (LMB)	UEPAB	NA	NA	NA	NA	NA	NA	NA	\$2.35	NA
2-wire voice unbundled TN Bus 2-Way Area Calling Port Economy Option (TACC1)	UEPAC	NA	NA	NA	NA	NA	NA	NA	NA	\$1.90
2-wire voice unbundled TN Bus 2-Way Area Calling Port Standard Option (TACC2)	UEPAD	NA	NA	NA	NA	NA	NA	NA	NA	\$1.90
2-wire voice unbundled TN Bus 2-WAY Collierville and Memphis Local Calling Port (B2F)	UEPAE	NA	NA	NA	NA	NA	NA	NA	NA	\$1.90
LOCAL NUMBER PORTABILITY (REQUIRES ONE PER PORT)										
LNPCX										
Non-Recurring Charges (NRC) - 1st (Residence)										
2- wire voice unbundled port - residence	UEPRL	\$21.93	\$38.00	\$17.16	\$37.78	\$16.43	\$22.98	\$21.60	\$24.98	BST GSST A4.3.1
2-wire voice unbundled port with caller ID - residence	UEPRC	\$21.93	\$38.00	\$17.16	\$37.78	\$16.43	\$22.98	\$24.04	\$24.98	BST GSST A4.3.1
2-wire voice unbundled port outgoing only - residence	UEPRO	\$21.93	\$38.00	\$17.16	\$37.78	\$16.43	\$22.98	\$24.04	\$24.98	BST GSST A4.3.1
2-wire voice unbundled area plus port with caller ID - residence	UEPRM	\$21.93	\$38.00	\$17.16	\$37.78	\$16.43	\$22.98	\$24.04	\$24.98	BST GSST A4.3.1
2-wire voice unbundled Florida area calling with caller ID - residence	UEPAF	NA	\$38.00	NA	NA	NA	NA	NA	NA	NA
2-wire voice unbundled Louisiana Area Plus with caller ID - residence (RUL)	UEPAG	NA	NA	NA	NA	\$16.43	NA	NA	NA	NA
2-wire voice unbundled Louisiana Area Plus with caller ID - residence (AC7)	UEPAH	NA	NA	NA	NA	\$16.43	NA	NA	NA	NA
2-wire voice unbundled South Carolina Area Calling port with Caller ID - residence (LW8)	UEPAJ	NA	NA	NA	NA	NA	NA	NA	\$24.98	NA

**BELLSOUTH/LEVEL 3 RATES
NETWORK ELEMENTS
AND OTHER SERVICES**

DESCRIPTION		USOC	AL	FL	GA	KY	LA	MS	NC	SC	TN
	2-wire voice unbundled Tennessee Area Calling port with Caller ID - residence (F2R)	UEPAK	NA	NA	NA	NA	NA	NA	NA	NA	BST GSST A4.3.1
	2-wire voice unbundled Tennessee Area Calling port with Caller ID - residence (TACER)	UEPAL	NA	NA	NA	NA	NA	NA	NA	NA	BST GSST A4.3.1
	2-wire voice unbundled Tennessee Area Calling port with Caller ID - residence (TACSR)	UEPAM	NA	NA	NA	NA	NA	NA	NA	NA	BST GSST A4.3.1
	2-wire voice unbundled Tennessee Area Calling port with Caller ID - residence (1MF2X)	UEPAN	NA	NA	NA	NA	NA	NA	NA	NA	BST GSST A4.3.1
	2-wire voice unbundled Tennessee Area Calling port with Caller ID - residence (2MR)	UEPAO	NA	NA	NA	NA	NA	NA	NA	NA	BST GSST A4.3.1
	2-wire voice unbundled Res Low Usage Line Port with Caller+E563 ID (LUM)	UEPAP	\$21.93	\$38.00	\$17.16	\$37.78	\$16.43	\$22.98	\$24.04	\$24.98	BST GSST A4.3.1
	NRC - Add'l (Residence)										
	2- wire voice unbundled port - residence -	UEPRL	\$21.93	\$15.00	\$17.16	\$37.78	\$16.43	\$22.98	\$21.60	\$24.98	BST GSST A4.3.1
	2-wire voice unbundled port with caller ID - residence	UEPRC	\$21.93	\$15.00	\$17.16	\$37.78	\$16.43	\$22.98	\$9.08	\$24.98	BST GSST A4.3.1
	2-wire voice unbundled port outgoing only - residence	UEPRO	\$21.93	\$15.00	\$17.16	\$37.78	\$16.43	\$22.98	\$9.08	\$24.98	BST GSST A4.3.1
	2-wire voice unbundled area plus port with caller ID - residence	UEPRM	\$21.93	\$15.00	\$17.16	\$37.78	\$16.43	\$22.98	\$9.08	\$24.98	BST GSST A4.3.1
	2-wire voice unbundled Florida area calling with caller ID - residence	UEPAF	NA	\$15.00	NA	NA	NA	NA	NA	NA	NA
	2-wire voice unbundled Louisiana Area Plus with caller ID - residence (RUL)	UEPAG	NA	NA	NA	NA	\$16.43	NA	NA	NA	NA
	2-wire voice unbundled Louisiana Area Plus with caller ID - residence (AC7)	UEPAH	NA	NA	NA	NA	\$16.43	NA	NA	NA	NA
	2-wire voice unbundled South Carolina Area Calling port with Caller ID - residence (LW8)	UEPAJ	NA	NA	NA	NA	NA	NA	NA	\$24.98	NA
	2-wire voice unbundled Tennessee Area Calling port with Caller ID - residence (F2R)	UEPAK	NA	NA	NA	NA	NA	NA	NA	NA	BST GSST A4.3.1
	2-wire voice unbundled Tennessee Area Calling port with Caller ID - residence (TACER)	UEPAL	NA	NA	NA	NA	NA	NA	NA	NA	BST GSST A4.3.1
	2-wire voice unbundled Tennessee Area Calling port with Caller ID - residence (TACSR)	UEPAM	NA	NA	NA	NA	NA	NA	NA	NA	BST GSST A4.3.1
	2-wire voice unbundled Tennessee Area Calling port with Caller ID - residence (1MF2X)	UEPAN	NA	NA	NA	NA	NA	NA	NA	NA	BST GSST A4.3.1
	2-wire voice unbundled Tennessee Area Calling port with Caller ID - residence (2MR)	UEPAO	NA	NA	NA	NA	NA	NA	NA	NA	BST GSST A4.3.1
	2-wire voice unbundled Res Low Usage Line Port with Caller ID (LUM)	UEPAP	\$21.93	\$15.00	\$17.16	\$37.78	\$16.43	\$22.98	\$9.08	\$24.98	BST GSST A4.3.1
	NRC - 1st (Business)										
	2-wire Voice Unbundled Port without Caller ID	UEPBL	\$21.93	\$38.00	\$17.16	\$37.55	\$16.43	\$22.98	\$21.60	\$24.98	BST GSST A4.3.1
	2-wire voice unbundled port with Caller ID	UEPBC	\$21.93	\$38.00	\$17.16	\$37.55	\$16.43	\$22.98	\$24.04	\$24.98	BST GSST A4.3.1
	2-wire voice unbundled outgoing only port	UEPBO	\$21.93	\$38.00	\$17.16	\$37.55	\$16.43	\$22.98	\$24.04	\$24.98	BST GSST A4.3.1
	2-wire voice unbundled Area Plus Port with Caller ID	UEPBM	\$21.93	\$38.00	\$17.16	\$37.55	\$16.43	\$22.98	\$24.04	\$24.98	BST GSST A4.3.1
	2-wire voice unbundled Incoming only Port with Caller ID	UEPB1	\$21.93	\$38.00	\$17.16	\$37.55	\$16.43	\$22.98	\$24.04	\$24.98	BST GSST A4.3.1
	2-wire voice unbundled LA Bus Area Calling Port with Caller ID (BUC)	UEPAA	NA	NA	NA	NA	\$16.43	NA	NA	NA	NA
	2-wire voice unbundled SC Bus Area Calling Port with Caller ID+E587 (LMB)	UEPAB	NA	NA	NA	NA	NA	NA	NA	\$24.98	NA

BELLSOUTH/LEVEL 3 RATES
NETWORK ELEMENTS
AND OTHER SERVICES

DESCRIPTION		USOC	AL	FL	GA	KY	LA	MS	NC	SC	TN
	2-wire voice unbundled TN Bus 2-way Area Calling Port Economy Option (TACC1)	UEPAC	NA	NA	NA	NA	NA	NA	NA	NA	BST GSST A4.3.1
	2-wire voice unbundled TN Bus 2-way Area Calling Port Standard Option (TACC2)	UEPAD	NA	NA	NA	NA	NA	NA	NA	NA	BST GSST A4.3.1
	2-wire voice unbundled TN Bus 2-way Collierville and Memphis Local Calling Port (B2F)	UEPAE	NA	NA	NA	NA	NA	NA	NA	NA	BST GSST A4.3.1
											BST GSST A4.3.1
	NRC - Add'l (Business)	UEPBL	\$21.93	\$15.00	\$17.16	\$37.55	\$16.43	\$22.98	\$9.08	\$24.98	BST GSST A4.3.1
	2-wire voice unbundled port without Caller ID	UEPBL	\$21.93	\$15.00	\$17.16	\$37.55	\$16.43	\$22.98	\$21.60	\$24.98	BST GSST A4.3.1
	2-wire voice unbundled port with Caller ID	UEPBC	\$21.93	\$15.00	\$17.16	\$37.55	\$16.43	\$22.98	\$9.08	\$24.98	BST GSST A4.3.1
	2-wire voice unbundled outgoing only port	UEPBO	\$21.93	\$15.00	\$17.16	\$37.55	\$16.43	\$22.98	\$9.08	\$24.98	BST GSST A4.3.1
	2-wire voice unbundled Area Plus Port with Caller ID	UEPBM	\$21.93	\$15.00	\$17.16	\$37.55	\$16.43	\$22.98	\$9.08	\$24.98	BST GSST A4.3.1
	2-wire voice unbundled incoming only port with Caller ID	UEPB1	\$21.93	\$15.00	\$17.16	\$37.55	\$16.43	\$22.98	\$9.08	\$24.98	BST GSST A4.3.1
	2-wire voice unbundled LA Bus Area Calling Port with Caller ID (BUC)	UEPAA	NA	NA	NA	NA	\$16.43	NA	NA	NA	NA
	2-wire voice unbundled SC Bus Area Calling Port with Caller ID (LMB)	UEPAB	NA	NA	NA	NA	NA	NA	NA	\$24.98	NA
	2-wire voice unbundled TN Bus 2-way Area Calling Port Economy Option (TACC1)	UEPAC	NA	NA	NA	NA	NA	NA	NA	NA	BST GSST A4.3.1
	2-wire voice unbundled TN Bus 2-way Area Calling Port Standard Option (TACC2)	UEPAD	NA	NA	NA	NA	NA	NA	NA	NA	BST GSST A4.3.1
	2-wire voice unbundled TN Bus 2-way Collierville and Memphis Local Calling Port (B2F)	UEPAE	NA	NA	NA	NA	NA	NA	NA	NA	BST GSST A4.3.1
	NRC - Disconnect Charge - 1st										
	2-wire voice unbundled port - residence		\$6.21	NA	NA	NA	\$4.38	\$6.56	NA	NA	NA
	2-wire voice unbundled port with caller ID - residence		\$6.21	NA	NA	NA	\$4.38	\$6.56	NA	NA	NA
	2-wire voice unbundled port outgoing only - residence		\$6.21	NA	NA	NA	\$4.38	\$6.56	NA	NA	NA
	2-wire voice unbundled area plus port with caller ID - residence		\$6.21	NA	NA	NA	\$4.38	\$6.56	NA	NA	NA
	2-wire voice unbundled Florida area calling with caller ID - residence		NA	NA	NA	NA	NA	NA	NA	NA	NA
	2-wire voice unbundled Louisiana Area Plus with caller ID - residence (RUL)		NA	NA	NA	NA	\$4.38	NA	NA	NA	NA
	2-wire voice unbundled Louisiana Area Plus with caller ID - residence (AC7)		NA	NA	NA	NA	\$4.38	NA	NA	NA	NA
	2-wire voice unbundled South Carolina Area Calling port with Caller ID - residence (LW8)		NA	NA	NA	NA	NA	NA	NA	NA	NA
	2-wire voice unbundled Tennessee Area Calling port with Caller ID - residence (F2R)		NA	NA	NA	NA	NA	NA	NA	NA	NA
	2-wire voice unbundled Tennessee Area Calling port with Caller ID - residence (TACER)		NA	NA	NA	NA	NA	NA	NA	NA	NA
	2-wire voice unbundled Tennessee Area Calling port with Caller ID - residence (TACSR)		NA	NA	NA	NA	NA	NA	NA	NA	NA
	2-wire voice unbundled Tennessee Area Calling port with Caller ID - residence (1MF2X)		NA	NA	NA	NA	NA	NA	NA	NA	NA
	2-wire voice unbundled Tennessee Area Calling port with Caller ID - residence (2MR)		NA	NA	NA	NA	NA	NA	NA	NA	NA
	2-wire voice unbundled Res Low Usage Line Port with Caller ID (LUM)		\$6.21	NA	NA	NA	\$4.38	\$6.56	NA	NA	NA
	2-wire voice unbundled port without Caller ID		\$6.21	NA	NA	NA	\$4.38	\$6.56	NA	NA	NA
	2-wire voice unbundled port with Caller ID		\$6.21	NA	NA	NA	\$4.38	\$6.56	NA	NA	NA
	2-wire voice unbundled outgoing only Port		\$6.21	NA	NA	NA	\$4.38	\$6.56	NA	NA	NA
	2-wire voice unbundled Area Plus Port with Caller ID		\$6.21	NA	NA	NA	\$4.38	\$6.56	NA	NA	NA

BELLSOUTH/LEVEL 3 RATES
NETWORK ELEMENTS
AND OTHER SERVICES

DESCRIPTION	USOC	AL	FL	GA	KY	LA	MS	NC	SC	TN
2-wire voice unbundled Incoming only Port with Caller ID		\$6.21	NA	NA	NA	\$4.38	\$6.56	NA	NA	NA
2-wire voice unbundled LA Bus Area Calling Port with Caller ID (BUC)		NA	NA	NA	NA	\$4.38	NA	NA	NA	NA
2-wire voice unbundles SC Bus Area Calling Port with Caller ID (LMB)		NA	NA	NA	NA	NA	NA	NA	NA	NA
2-wire voice unbundled TN Bus 2-way Area Calling Port Economy Option (TACC1)		NA	NA	NA	NA	NA	NA	NA	NA	NA
2-wire voice unbundled TN Bus 2-way Area Calling Port Standard Option (TACC2)		NA	NA	NA	NA	NA	NA	NA	NA	NA
2-wire voice unbundled TN Bus 2-Way Collierville and Memphis Local Calling Port (B2F)		NA	NA	NA	NA	NA	NA	NA	NA	NA
NRC - Disconnect Charge - Add'l										
2-wire voice unbundled port - residence		\$6.21	NA	NA	NA	\$4.38	\$6.56	NA	NA	NA
2-wire voice unbundled port with caller ID - residence		\$6.21	NA	NA	NA	\$4.38	\$6.56	NA	NA	NA
2-wire voice unbundled port outgoing only - residence		\$6.21	NA	NA	NA	\$4.38	\$6.56	NA	NA	NA
2-wire voice unbundled area plus port with caller ID - residence		\$6.21	NA	NA	NA	\$4.38	\$6.56	NA	NA	NA
2-wire voice unbundled Florida area calling with caller ID - residence		NA	NA	NA	NA	NA	NA	NA	NA	NA
2-wire voice unbundled Louisiana Area Plus with caller ID - residence (RUL)		NA	NA	NA	NA	\$4.38	NA	NA	NA	NA
2-wire voice unbundled Louisiana Area Plus with caller ID - residence (AC7)		NA	NA	NA	NA	\$4.38	NA	NA	NA	NA
2-wire voice unbundled South Carolina Area Calling port with Caller ID - residence (LW8)		NA	NA	NA	NA	NA	NA	NA	NA	NA
2-wire voice unbundled Tennessee Area Calling port with Caller ID - residence (F2R)		NA	NA	NA	NA	NA	NA	NA	NA	NA
2-wire voice unbundled Tennessee Area Calling port with Caller ID - residence (TACER)		NA	NA	NA	NA	NA	NA	NA	NA	NA
2-wire voice unbundled Tennessee Area Calling port with Caller ID - residence (TACSR)		NA	NA	NA	NA	NA	NA	NA	NA	NA
2-wire voice unbundled Tennessee Area Calling port with Caller ID - residence (1MF2X)		NA	NA	NA	NA	NA	NA	NA	NA	NA
2-wire voice unbundled Tennessee Area Calling port with Caller ID - residence (2MR)		NA	NA	NA	NA	\$4.38	\$6.56	NA	NA	NA
2-wire voice unbundled Res Low Usage Line Port with Caller ID (LUM)		\$6.21	NA	NA	NA	\$4.38	\$6.56	NA	NA	NA
2-wire voice unbundled port without Caller ID		\$6.21	NA	NA	NA	\$4.38	\$6.56	NA	NA	NA
2-wire voice unbundled port with Caler ID		\$6.21	NA	NA	NA	\$4.38	\$6.56	NA	NA	NA
2-wire voice unbundled outgoing only port		\$6.21	NA	NA	NA	\$4.38	\$6.56	NA	NA	NA
2-wire voice unbundled Area Plus Port with Caller ID		\$6.21	NA	NA	NA	\$4.38	\$6.56	NA	NA	NA
2-wire voice unbundled incoming only port with Caller ID		\$6.21	NA	NA	NA	\$4.38	\$6.56	NA	NA	NA
2-wire voice unbundled LA Bus Area Calling Port with Caller ID (BUC)		NA	NA	NA	NA	\$4.38	NA	NA	NA	NA
2-wire voice unbundled SC Bus Area Calling Port with Caller ID (LMB)		NA	NA	NA	NA	NA	NA	NA	NA	NA
2-wire voice unbundled TN Bus 2-way Area Calling Port Economy Option (TACC1)		NA	NA	NA	NA	NA	NA	NA	NA	NA
2-wire voice unbundled TN Bus 2-way Area Calling Port Standard Option (TACC2)		NA	NA	NA	NA	NA	NA	NA	NA	NA
2-wire voice unbundled TN Bus 2-way Collierville and Memphis Local Calling Port (B2F)		NA	NA	NA	NA	NA	NA	NA	NA	NA
NRC - Incremental Charge - Manual Service Order - 1st	SOMAN	\$27.37	NA	\$18.94	NA	\$18.14	\$25.52	\$26.94	\$44.42	NA
NRC - Incremental Charge - Manual Service Order - Add'l	SOMAN	\$12.97	NA	\$8.42	NA	\$8.06	\$11.34	\$12.76	\$14.63	NA
NRC - Incremental Charge - Manual Service Order - Disconnect - 1st	SOMAN	\$17.77	NA	NA	NA	\$10.39	\$16.06	NA	NA	NA
NRC - Incremental Charge - Manual Service Order - Disconnect - Add'l	SOMAN	\$1.44	NA	NA	NA	NA	NA	NA	NA	NA
All available features, per month	UEPVF	\$5.55	NA	NA	NA	\$8.28	\$6.75	NA	\$6.29	NA
NRC - 1st (all types)		\$24.72	NA	NA	NA	NA	\$21.42	NA	\$36.24	NA
NRC - Add'l (all types)		\$24.72	NA	NA	NA	NA	\$21.42	NA	\$36.24	NA
NRC - Disconnect Charge - 1st		\$18.41	NA	NA	NA	NA	\$19.68	NA	NA	NA

BELLSOUTH/LEVEL 3 RATES
NETWORK ELEMENTS
AND OTHER SERVICES

DESCRIPTION	USOC	AL	FL	GA	KY	LA	MS	NC	SC	TN
NRC - Disconnect Charge - Add'l		\$18.41	NA	NA	NA	NA	\$19.68	NA	NA	NA
NRC - Incremental Charge - Manual Service Order - 1st	SOMAN	\$27.37	NA	NA	NA	NA	\$25.52	NA	\$44.42	NA
NRC - Incremental Charge - Manual Service Order - Add'l	SOMAN	\$12.97	NA	NA	NA	NA	\$11.34	NA	\$14.63	NA
NRC - Incremental Charge - Manual Service Order - Disconnect - 1st	SOMAN	\$17.77	NA	NA	NA	NA	\$16.06	NA	NA	NA
NRC - Incremental Charge - Manual Service Order - Disconnect - Add'l	SOMAN	\$1.44	NA	NA	NA	NA	NA	NA	NA	NA
Three available feature, per month	UEPVF	NA	NA	NA	NA	\$8.28	\$3.31	NA	\$3.03	NA
NRC - 1st (all types)		NA	NA	NA	NA	NA	\$3.06	NA	\$4.53	NA
NRC - Add'l (all types)		NA	NA	NA	NA	NA	\$3.06	NA	\$4.53	NA
NRC - Disconnect Charge - 1st		NA	NA	NA	NA	NA	\$8.20	NA	NA	NA
NRC - Disconnect Charge - Add'l		NA	NA	NA	NA	NA	\$8.20	NA	NA	NA
NRC - Incremental Charge - Manual Service Order - 1st	SOMAN	NA	NA	NA	NA	NA	\$25.52	NA	\$44.42	NA
NRC - Incremental Charge - Manual Service Order - Add'l	SOMAN	NA	NA	NA	NA	NA	\$11.34	NA	\$14.63	NA
NRC - Incremental Charge - Manual Service Order - Disconnect - 1st	SOMAN	NA	NA	NA	NA	NA	\$16.06	NA	NA	NA
NRC - Incremental Charge - Manual Service Order - Disconnect - Add'l	SOMAN	NA	NA	NA	NA	NA	NA	NA	NA	NA
4-Wire Analog VG Port, per month	UEP4A	NA	\$9.14	\$8.47	NA	\$10.13	\$9.60	\$8.69	\$2.28	NA
NRC - 1st	UEP4A	NA	\$5.86	\$17.16	NA	\$16.43	\$22.98	\$21.69	\$3.50	NA
NRC - Add'l	UEP4A	NA	\$5.86	\$17.16	NA	\$16.43	\$22.98	\$21.69	\$3.50	NA
NRC - Disconnect Charge - 1st	BFR	NA	NA	NA	NA	\$3.77	\$6.56	NA	NA	NA
NRC - Disconnect Charge - Add'l	BFR	NA	NA	NA	NA	\$3.77	\$6.56	NA	NA	NA
NRC - Incremental Charge - Manual Service Order - 1st	SOMAN	NA	NA	\$18.94	NA	\$18.14	\$25.52	\$26.85	NA	NA
NRC - Incremental Charge - Manual Service Order - Add'l	SOMAN	NA	NA	\$8.42	NA	\$8.06	\$11.34	\$12.67	NA	NA
NRC - Incremental Charge - Manual Service Order - Disconnect - 1st	SOMAN	NA	NA	NA	NA	\$8.94	\$16.06	NA	NA	NA
2-Wire DID Port, per month	UEPP2	\$12.08	TBD	\$11.35	NA	\$13.12	\$14.63	\$12.36	\$12.08	\$12.68
NRC - 1st	UEPP2	\$50.00	TBD	\$61.91	NA	\$59.28	\$83.09	\$81.84	\$50.00	BST GSST A4.3.1
NRC - Add'l	UEPP2	\$18.00	TBD	\$61.91	NA	\$59.28	\$83.09	\$81.84	\$50.00	BST GSST A4.3.1
NRC - Disconnect Charge - 1st	UEPP2	NA	NA	NA	NA	\$9.20	\$13.48	NA	NA	NA
NRC - Disconnect Charge - Add'l	UEPP2	NA	NA	NA	NA	\$9.20	\$13.48	NA	NA	NA
NRC - Incremental Charge - Manual Service Order - 1st	SOMAN	NA	NA	\$18.94	NA	\$18.14	\$25.52	\$26.94	NA	NA
NRC - Incremental Charge - Manual Service Order - Add'l	SOMAN	NA	NA	\$8.42	NA	\$8.06	\$11.34	\$12.76	NA	NA
NRC - Incremental Charge - Manual Service Order - Disconnect - 1st	SOMAN	NA	NA	NA	NA	\$10.39	\$16.07	NA	NA	NA
4-Wire DS1 Port w/DID capability, per month	UEPDD	\$130.23	\$125.00	\$120.80	NA	\$149.27	\$146.46	\$123.65	\$130.23	\$120.00
NRC - 1st	UEPDD	\$50.00	\$112.00	\$89.44	NA	\$85.63	\$117.81	\$116.59	\$60.00	To be negotiated
NRC - Add'l	UEPDD	\$18.00	\$91.00	\$52.46	NA	\$50.23	\$71.18	\$69.92	\$60.00	To be negotiated
NRC - Disconnect Charge - 1st	UEPDD	NA	NA	NA	NA	\$8.82	\$12.94	NA	NA	NA
NRC - Disconnect Charge - Add'l	UEPDD	NA	NA	NA	NA	\$8.82	\$12.94	NA	NA	NA
NRC - Incremental Charge - Manual Service Order - 1st	SOMAN	NA	NA	\$18.94	NA	\$18.14	\$25.52	\$26.94	NA	NA
NRC - Incremental Charge - Manual Service Order - Add'l	SOMAN	NA	NA	\$8.42	NA	\$8.06	\$11.34	\$12.76	NA	NA
NRC - Incremental Charge - Manual Service Order - Disconnect - 1st	SOMAN	NA	NA	NA	NA	\$10.39	\$16.06	NA	NA	NA
2-Wire ISDN Port(2) (3), per month	U1PMA	\$16.42	\$13.00	\$13.47	\$12.33	\$23.33	\$51.91	\$24.50	\$33.74	\$1.90
NRC - 1st	U1PMA	\$63.24	\$88.00	\$47.37	\$90.48	\$45.35	\$63.59	\$62.29	\$65.79	BST GSST A4.3.1
NRC - Add'l	U1PMA	\$63.24	\$66.00	\$47.37	\$84.53	\$45.35	\$63.59	\$62.29	\$65.79	BST GSST A4.3.1
NRC - Disconnect Charge - 1st	U1PMA	\$5.69	NA	NA	NA	\$4.31	\$7.04	NA	NA	NA
NRC - Disconnect Charge - Add'l	U1PMA	\$5.69	NA	NA	NA	\$4.31	\$7.04	NA	NA	NA
NRC - Incremental Charge - Manual Service Order - 1st	SOMAN	\$56.19	NA	\$39.98	NA	\$38.29	\$53.87	\$55.30	\$67.52	NA
NRC - Incremental Charge - Manual Service Order - Add'l	SOMAN	\$56.19	NA	\$39.98	NA	\$38.29	\$53.87	\$55.30	\$67.52	NA
NRC - Incremental Charge - Manual Service Order - Disconnect - 1st	SOMAN	\$12.97	NA	NA	NA	\$6.65	\$11.34	NA	NA	NA
NRC - Incremental Charge - Manual Service Order - Disconnect - Add'l	SOMAN	\$12.97	NA	NA	NA	\$6.65	\$11.34	NA	NA	NA
NRC - User Profile per B Channel (4)	U1UMA	NA	NA	NA	\$5.61	NA	NA	NA	NA	NA

BELLSOUTH/LEVEL 3 RATES
NETWORK ELEMENTS
AND OTHER SERVICES

DESCRIPTION	USOC	AL	FL	GA	KY	LA	MS	NC	SC	TN
2-Wire ISDN Port(2) (3) including all available features, per month	U1PMA	NA	NA	NA	NA	NA	NA	NA	\$38.68	NA
NRC - 1st	U1PMA	NA	NA	NA	NA	NA	NA	NA	\$106.40	NA
NRC - Add'l	U1PMA	NA	NA	NA	NA	NA	NA	NA	\$106.40	NA
NRC - Incremental Charge - Manual Service Order - 1st	SOMAN	NA	NA	NA	NA	NA	NA	NA	\$67.52	NA
NRC - Incremental Charge - Manual Service Order - Add'l	SOMAN	NA	NA	NA	NA	NA	NA	NA	\$67.52	NA
2-Wire ISDN Port(2) (3) including three available features, per month	U1PMA	NA	NA	NA	NA	NA	NA	NA	\$36.01	NA
NRC - 1st	U1PMA	NA	NA	NA	NA	NA	NA	NA	\$70.32	NA
NRC - Add'l	U1PMA	NA	NA	NA	NA	NA	NA	NA	\$70.32	NA
NRC - Incremental Charge - Manual Service Order - 1st	SOMAN	NA	NA	NA	NA	NA	NA	NA	\$67.52	NA
NRC - Incremental Charge - Manual Service Order - Add'l	SOMAN	NA	NA	NA	NA	NA	NA	NA	\$67.52	NA
4-Wire ISDN DS1 Port, per month	UEPEX	\$186.02	NA	\$163.16	NA	\$194.72	\$213.21	\$179.75	\$214.79	\$308.00
NRC - 1st	UEPEX	\$244.85	NA	\$186.80	NA	\$181.89	\$244.12	\$241.63	\$278.37	To be negotiated
NRC - Add'l	UEPEX	\$244.85	NA	\$186.80	NA	\$181.89	\$244.12	\$241.63	\$278.37	To be negotiated
NRC - Disconnect Charge - 1st	UEPEX	\$51.19	NA	NA	NA	\$27.11	\$53.32	NA	NA	NA
NRC - Disconnect Charge - Add'l	UEPEX	\$51.19	NA	NA	NA	\$27.11	\$53.32	NA	NA	NA
NRC - Incremental Charge - Manual Service Order - 1st	SOMAN	\$54.75	NA	\$37.88	NA	\$33.18	\$51.03	\$53.89	\$65.48	NA
NRC - Incremental Charge - Manual Service Order - Add'l	SOMAN	\$54.75	NA	\$37.88	NA	\$33.18	\$51.03	\$53.89	\$65.48	NA
NRC - Incremental Charge - Manual Service Order - Disconnect - 1st	SOMAN	\$11.53	NA	NA	NA	\$7.73	\$8.51	NA	NA	NA
NRC - Incremental Charge - Manual Service Order - Disconnect - Add'l	SOMAN	\$11.53	NA	NA	NA	\$7.73	\$8.51	NA	NA	NA
4-Wire ISDN DS1 Port including all available features, per month	UEPEX	NA	NA	NA	\$275.48	NA	NA	NA	\$251.00	NA
NRC - 1st	UEPEX	NA	NA	NA	\$181.27	NA	NA	NA	\$311.73	NA
NRC - Add'l	UEPEX	NA	NA	NA	\$116.42	NA	NA	NA	\$311.73	NA
NRC - Incremental Charge - Manual Service Order - 1st	SOMAN	NA	NA	NA	NA	NA	NA	NA	\$65.48	NA
NRC - Incremental Charge - Manual Service Order - Add'l	SOMAN	NA	NA	NA	NA	NA	NA	NA	\$65.48	NA
2-Wire Analog Line Port (PBX), per month										
2 WIRE VOICE UNBUNDLED COMBINATION 2-WAY PBX TRUNK - Residence	UEPRD	\$2.07	\$2.00	\$1.85	\$2.61	\$2.20	\$2.11	\$2.18	\$2.35	\$1.90
LINE SIDE UNBUNDLED COMBINATION 2-WAY PBX TRUNK - BUSINESS	UEPPC	\$2.07	\$2.00	\$1.85	\$2.61	\$2.20	\$2.11	\$2.00	\$2.35	\$1.90
LINE SIDE UNBUNDLED OUTWARD PBX TRUNK - BUSINESS	UEPPO	\$2.07	\$2.00	\$1.85	\$2.61	\$2.20	\$2.11	\$2.00	\$2.35	\$1.90
LINE SIDE UNBUNDLED INCOMING PBX TRUNK - BUSINESS	UEPP1	\$2.07	\$2.00	\$1.85	\$2.61	\$2.20	\$2.11	\$2.00	\$2.35	\$1.90
LONG DISTANCE TERMINAL PBX TRUNK-BUSINESS	UEPLD	\$2.07	\$2.00	\$1.85	\$2.61	\$2.20	\$2.11	\$2.00	\$2.35	\$1.90
TN 2-WAY CALLING PLAN PBX TRUNK - BUSINESS	UEPT2	\$2.07	\$2.00	\$1.85	\$2.61	\$2.20	\$2.11	\$2.00	\$2.35	\$1.90
TN OUTWARD CALLING PLAN PBX TRUNK - BUSINESS	UEPTO	\$2.07	\$2.00	\$1.85	\$2.61	\$2.20	\$2.11	\$2.00	\$2.35	\$1.90
2-WIRE VOICE UNBUNDLED 2-WAY COMBINATION PBX ALABAMA CALLING PORT	UEPA2	\$2.07	NA	NA	NA	NA	NA	NA	NA	NA
2-WIRE VOICE UNBUNDLED 2-WAY COMBINATION PBX LOUISIANA CALLING PORT	UEPL2	NA	NA	NA	NA	\$2.20	NA	NA	NA	NA
2-WIRE VOICE UNBUNDLED PBX LD TERMINAL PORTS	UEPLD	\$2.07	\$2.00	\$1.85	\$2.61	\$2.20	\$2.11	\$2.00	\$2.35	\$1.90
2-WIRE VOICE UNBUNDLED 2-WAY COMBINATION PBX TENNESSEE CALLING PORT	UEPT2	NA	NA	NA	NA	NA	NA	NA	NA	\$1.90
2-WIRE VOICE UNBUNDLED 1-WAY OUTGOING PBX TENNESSEE CALLING PORT	UEPTO	NA	NA	NA	NA	NA	NA	NA	NA	\$1.90
2-WIRE VOICE UNBUNDLED 2-WAY COMBINATION PBX USAGE PORT	UEPXA	\$2.07	\$2.00	\$1.85	\$2.61	\$2.20	\$2.11	\$2.00	\$2.35	\$1.90
2-WIRE VOICE UNBUNDLED PBX TOLL TERMINAL HOTEL PORTS	UEPXB	\$2.07	\$2.00	\$1.85	\$2.61	\$2.20	\$2.11	\$2.00	\$2.35	\$1.90
2-WIRE VOICE UNBUNDLED PBX LD DDD TERMINALS PORT	UEPXC	\$2.07	\$2.00	\$1.85	\$2.61	\$2.20	\$2.11	\$2.00	\$2.35	\$1.90
2-WIRE VOICE UNBUNDLED PBX LD TERMINAL SWITCHBOARD PORT	UEPXD	\$2.07	\$2.00	\$1.85	\$2.61	\$2.20	\$2.11	\$2.00	\$2.35	\$1.90
2-WIRE VOICE UNBUNDLED PBX LD TERMINAL SWITCHBOARD IDD CAPABLE PORT	UEPXE	\$2.07	\$2.00	\$1.85	\$2.61	\$2.20	\$2.11	\$2.00	\$2.35	\$1.90
2-WIRE VOICE UNBUNDLED 2-WAY PBX KENTUCKY ROOM AREA CALLING PORT WITHOUT LUD	UEPXF	NA	NA	NA	\$2.61	NA	NA	NA	NA	NA
2-WIRE VOICE UNBUNDLED PBX KENTUCKY LUD AREA CALLING PORT	UEPXG	NA	NA	NA	\$2.61	NA	NA	NA	NA	NA

BELLSOUTH/LEVEL 3 RATES
NETWORK ELEMENTS
AND OTHER SERVICES

DESCRIPTION	USOC	AL	FL	GA	KY	LA	MS	NC	SC	TN
2-WIRE VOICE UNBUNDLED PBX KENTUCKY PREMIUM CALLING PORT	UEPXH	NA	NA	NA	\$2.61	NA	NA	NA	NA	NA
2-WIRE VOICE UNBUNDLED 2-WAY KENTUCKY AREA CALLING PORT WITHOUT LUD	UEPXJ	NA	NA	NA	\$2.61	NA	NA	NA	NA	NA
2-WIRE VOICE UNBUNDLED 2-WAY PBX LOUISIANA LOCAL OPTIONAL CALLING PORT	UEPXK	NA	NA	NA	NA	\$2.20	NA	NA	NA	NA
2-WIRE VOICE UNBUNDLED 2-WAY PBX HOTEL/HOSPITAL ECONOMY ADMINISTRATIVE CALLING PORT	UEPXL	\$2.07	\$2.00	\$1.85	\$2.61	\$2.20	\$2.11	\$2.00	\$2.35	\$1.90
2-WIRE VOICE UNBUNDLED 2-WAY PBX HOTEL/HOSPITAL ECONOMY ROOM CALLING PORT	URPXM	\$2.07	\$2.00	\$1.85	\$2.61	\$2.20	\$2.11	\$2.00	\$2.35	\$1.90
2-WIRE VOICE UNBUNDLED 1-WAY OUTGOING PBX HOTEL/HOSPITAL ECONOMY ADMINIATRATIVE CALLING PORTTENNESSEE CALLING PORT	UEPXN	NA	NA	NA	NA	NA	NA	NA	NA	\$1.90
2-WIRE VOICE UNBUNDLED 1-WAY OUTGOING PBX HOTEL/HOSPITAL DIACOUNT ROOM CALLING PORT	UEPXO	\$2.07	\$2.00	\$1.85	\$2.61	\$2.20	\$2.11	\$2.00	\$2.35	\$1.90
2-WIRE VOICE UNBUNDLED 1-WAY OUTGOING PBX LOUISIANA LOCAL DISCOUNT CALLING PORT	UEPXP	NA	NA	NA	NA	\$2.20	NA	NA	NA	NA
2-WIRE VOICE UNBUNDLED 2-WAY PBX MISSISSIPPI LOCAL ECONOMY CALLING PORT	UEPXQ	NA	NA	NA	NA	NA	\$2.11	NA	NA	NA
2-WIRE VOICE UNBUNDLED 2-WAY PBX MISSISSIPPI LOCAL OPTIONAL CALLING PORT	UEPXR	NA	NA	NA	NA	NA	\$2.11	NA	NA	NA
2-WIRE VOICE UNBUNDLED 1-WAY OUTGOING PBXMEASURED PORT	UEPXS	\$2.07	\$2.00	\$1.85	\$2.61	\$2.20	\$2.11	\$2.00	\$2.35	\$1.90
2-WIRE VOICE UNBUNDLED 2-WAY PBX SOUTH CAROLINA AREA PLUS CALLING PORT	UEPXT	NA	NA	NA	NA	NA	NA	NA	\$2.35	NA
2-WIRE VOICE UNBUNDLED PBX COLLIERVERVILLE & MEMPHIS CALLING PORT	UEPXU	NA	NA	NA	NA	NA	NA	NA	NA	\$1.90
2-WIRE VOICE UNBUNDLED 2-WAY PBX TENNESSEE REGIONSERV CALLING PORT	UEPXV	NA	NA	NA	NA	NA	NA	NA	NA	\$1.90
UNBUNDLED LOOP BILLING USOC (REQUIRES ONE PER PORT)	UEPLX									
LOCAL NUMBER PORTABILITY (REQUIRES ONE PER PORT)	LNPCP									
NRC - 1st	UEPPC	\$21.93	\$38.00	\$17.16	\$36.47	\$16.43	\$22.98	\$24.04	\$24.36	NA
2 WIRE VOICE UNBUNDLED COMBINATION 2-WAY PBX TRUNK - Residence	UEPRD	\$21.93	\$38.00	\$17.16	\$36.47	\$16.43	\$22.98	\$21.60	\$24.36	NA
LINE SIDE UNBUNDLED COMBINATION 2-WAY PBX TRUNK - BUSINESS	UEPPC	\$21.93	\$38.00	\$17.16	\$36.47	\$16.43	\$22.98	\$24.04	\$24.36	NA
LINE SIDE UNBUNDLED OUTWARD PBX TRUNK - BUSINESS	UEPPO	\$21.93	\$38.00	\$17.16	\$36.47	\$16.43	\$22.98	\$24.04	\$24.36	NA
LINE SIDE UNBUNDLED INCOMING PBX TRUNK - BUSINESS	UEPP1	\$21.93	\$38.00	\$17.16	\$36.47	\$16.43	\$22.98	\$24.04	\$24.36	NA
LONG DISTANCE TERMINAL PBX TRUNK-BUSINESS	UEPLD	\$21.93	\$38.00	\$17.16	\$36.47	\$16.43	\$22.98	\$24.04	\$24.36	NA
TN 2-WAY CALLING PLAN PBX TRUNK - BUSINESS	UEPT2	\$21.93	\$38.00	\$17.16	\$36.47	\$16.43	\$22.98	\$24.04	\$24.36	NA
TN OUTWARD CALLING PLAN PBX TRUNK - BUSINESS	UEPTO	\$21.93	\$38.00	\$17.16	\$36.47	\$16.43	\$22.98	\$24.04	\$24.36	NA
2-WIRE VOICE UNBUNDLED 2-WAY COMBINATION PBX ALABAMA CALLING PORT	UEPA2	\$21.93	NA	NA	NA	NA	NA	NA	NA	NA
2-WIRE VOICE UNBUNDLED 2-WAY COMBINATION PBX LOUISIANA CALLING PORT	UEPL2	NA	NA	NA	NA	\$16.43	NA	NA	NA	NA
2-WIRE VOICE UNBUNDLED PBX LD TERMINAL PORTS	UEPLD	\$21.93	\$38.00	\$17.16	\$36.47	\$16.43	\$22.98	\$24.04	\$24.36	NA
2-WIRE VOICE UNBUNDLED 2-WAY COMBINATION PBX TENNESSEE CALLING PORT	UEPT2	NA	NA	NA	NA	NA	NA	NA	NA	NA
2-WIRE VOICE UNBUNDLED 1-WAY OUTGOING PBX TENNESSEE CALLING PORT	UEPTO	NA	NA	NA	NA	NA	NA	NA	NA	NA
2-WIRE VOICE UNBUNDLED 2-WAY COMBINATION PBX USAGE PORT	UEPXA	\$21.93	\$38.00	\$17.16	\$36.47	\$16.43	\$22.98	\$24.04	\$24.36	NA
2-WIRE VOICE UNBUNDLED PBX TOLL TERMINAL HOTEL PORTS	UEPXB	\$21.93	\$38.00	\$17.16	\$36.47	\$16.43	\$22.98	\$24.04	\$24.36	NA
2-WIRE VOICE UNBUNDLED PBX LD DDD TERMINALS PORT	UEPXC	\$21.93	\$38.00	\$17.16	\$36.47	\$16.43	\$22.98	\$24.04	\$24.36	NA

BELLSOUTH/LEVEL 3 RATES
NETWORK ELEMENTS
AND OTHER SERVICES

DESCRIPTION	USOC	AL	FL	GA	KY	LA	MS	NC	SC	TN
2-WIRE VOICE UNBUNDLED PBX LD TERMINAL SWITCHBOARD PORT	UEPXD	\$21.93	\$38.00	\$17.16	\$36.47	\$16.43	\$22.98	\$24.04	\$24.36	NA
2-WIRE VOICE UNBUNDLED PBX LD TERMINAL SWITCHBOARD IDD CAPABLE PORT	UEPXE	\$21.93	\$38.00	\$17.16	\$36.47	\$16.43	\$22.98	\$24.04	\$24.36	NA
2-WIRE VOICE UNBUNDLED 2-WAY PBX KENTUCKY ROOM AREA CALLING PORT WITHOUT LUD	UEPXF	NA	NA	NA	\$36.47	NA	NA	NA	NA	NA
2-WIRE VOICE UNBUNDLED PBX KENTUCKY LUD AREA CALLING PORT	UEPXG	NA	NA	NA	\$36.47	NA	NA	NA	NA	NA
2-WIRE VOICE UNBUNDLED PBX KENTUCKY PREMIUM CALLING PORT	UEPXH	NA	NA	NA	\$36.47	NA	NA	NA	NA	NA
2-WIRE VOICE UNBUNDLED 2-WAY KENTUCKY AREA CALLING PORT WITHOUT LUD	UEPXJ	NA	NA	NA	\$36.47	NA	NA	NA	NA	NA
2-WIRE VOICE UNBUNDLED 2-WAY PBX LOUISIANA LOCAL OPTIONAL CALLING PORT	UEPXK	NA	NA	NA	NA	\$16.43	NA	NA	NA	NA
2-WIRE VOICE UNBUNDLED 2-WAY PBX HOTEL/HOSPITAL ECONOMY ADMINISTRATIVE CALLING PORT	UEPXL	\$21.93	\$38.00	\$17.16	\$36.47	\$16.43	\$22.98	\$24.04	\$24.36	NA
2-WIRE VOICE UNBUNDLED 2-WAY PBX HOTEL/HOSPITAL ECONOMY ROOM CALLING PORT	URPXM	\$21.93	\$38.00	\$17.16	\$36.47	\$16.43	\$22.98	\$24.04	\$24.36	NA
2-WIRE VOICE UNBUNDLED 1-WAY OUTGOING PBX HOTEL/HOSPITAL ECONOMY ADMINISTRATIVE CALLING PORT TENNESSEE CALLING PORT	UEPXN	NA	NA	NA	NA	NA	NA	NA	NA	NA
2-WIRE VOICE UNBUNDLED 1-WAY OUTGOING PBX HOTEL/HOSPITAL DISCOUNT ROOM CALLING PORT	UEPXO	\$21.93	\$38.00	\$17.16	\$36.47	\$16.43	\$22.98	\$24.04	\$24.36	NA
2-WIRE VOICE UNBUNDLED 1-WAY OUTGOING PBX LOUISIANA LOCAL DISCOUNT CALLING PORT	UEPXP	NA	NA	NA	NA	\$16.43	NA	NA	NA	NA
2-WIRE VOICE UNBUNDLED 2-WAY PBX MISSISSIPPI LOCAL ECONOMY CALLING PORT	UEPXQ	NA	NA	NA	NA	NA	\$22.98	NA	NA	NA
2-WIRE VOICE UNBUNDLED 2-WAY PBX MISSISSIPPI LOCAL OPTIONAL CALLING PORT	UEPXR	NA	NA	NA	NA	NA	\$22.98	NA	NA	NA
2-WIRE VOICE UNBUNDLED 1-WAY OUTGOING PBX MEASURED PORT	UEPXS	\$21.93	\$38.00	\$17.16	\$36.47	\$16.43	\$22.98	\$24.04	\$24.36	NA
2-WIRE VOICE UNBUNDLED 2-WAY PBX SOUTH CAROLINA AREA PLUS CALLING PORT	UEPXT	NA	NA	NA	NA	NA	NA	NA	\$24.36	NA
2-WIRE VOICE UNBUNDLED PBX COLLIERVILLE & MEMPHIS CALLING PORT	UEPXU	NA	NA	NA	NA	NA	NA	NA	NA	NA
2-WIRE VOICE UNBUNDLED 2-WAY PBX TENNESSEE REGIONSERV CALLING PORT	UEPXV	NA	NA	NA	NA	NA	NA	NA	NA	NA
NRC - Add'l										
2 WIRE VOICE UNBUNDLED COMBINATION 2-WAY PBX TRUNK - Residence	UEPRD	\$21.93	\$15.00	\$17.16	\$36.47	\$16.43	\$22.98	\$21.60	\$24.36	NA
LINE SIDE UNBUNDLED COMBINATION 2-WAY PBX TRUNK - BUSINESS	UEPPC	\$21.93	\$15.00	\$17.16	\$36.47	\$16.43	\$22.98	\$9.05	\$24.36	NA
LINE SIDE UNBUNDLED OUTWARD PBX TRUNK - BUSINESS	UEPPO	\$21.93	\$15.00	\$17.16	\$36.47	\$16.43	\$22.98	\$9.05	\$24.36	NA
LINE SIDE UNBUNDLED INCOMING PBX TRUNK - BUSINESS	UEPP1	\$21.93	\$15.00	\$17.16	\$36.47	\$16.43	\$22.98	\$9.05	\$24.36	NA
LONG DISTANCE TERMINAL PBX TRUNK-BUSINESS	UEPLD	\$21.93	\$15.00	\$17.16	\$36.47	\$16.43	\$22.98	\$9.05	\$24.36	NA
TN 2-WAY CALLING PLAN PBX TRUNK - BUSINESS	UEPT2	\$21.93	\$15.00	\$17.16	\$36.47	\$16.43	\$22.98	\$9.05	\$24.36	NA
TN OUTWARD CALLING PLAN PBX TRUNK - BUSINESS	UEPTO	\$21.93	\$15.00	\$17.16	\$36.47	\$16.43	\$22.98	\$9.05	\$24.36	NA
2-WIRE VOICE UNBUNDLED 2-WAY COMBINATION PBX ALABAMA CALLING PORT	UEPA2	\$21.93	NA	NA	NA	NA	NA	NA	NA	NA
2-WIRE VOICE UNBUNDLED 2-WAY COMBINATION PBX LOUISIANA CALLING PORT	UEPL2	NA	NA	NA	NA	\$16.43	NA	NA	NA	NA
2-WIRE VOICE UNBUNDLED PBX LD TERMINAL PORTS	UEPLD	\$21.93	\$15.00	\$17.16	\$36.47	\$16.43	\$22.98	\$9.05	\$24.36	NA
2-WIRE VOICE UNBUNDLED 2-WAY COMBINATION PBX TENNESSEE CALLING PORT	UEPT2	NA	NA	NA	NA	NA	NA	NA	NA	NA
2-WIRE VOICE UNBUNDLED 1-WAY OUTGOING PBX TENNESSEE CALLING PORT	UEPTO	NA	NA	NA	NA	NA	NA	NA	NA	NA

BELLSOUTH/LEVEL 3 RATES
NETWORK ELEMENTS
AND OTHER SERVICES

DESCRIPTION	USOC	AL	FL	GA	KY	LA	MS	NC	SC	TN
2-WIRE VOICE UNBUNDLED 2-WAY COMBINATION PBX USAGE PORT	UEPXA	\$21.93	\$15.00	\$17.16	\$36.47	\$16.43	\$22.98	\$9.05	\$24.36	NA
2-WIRE VOICE UNBUNDLED PBX TOLL TERMINAL HOTEL PORTS	UEPXB	\$21.93	\$15.00	\$17.16	\$36.47	\$16.43	\$22.98	\$9.05	\$24.36	NA
2-WIRE VOICE UNBUNDLED PBX LD DDD TERMINALS PORT	UEPXC	\$21.93	\$15.00	\$17.16	\$36.47	\$16.43	\$22.98	\$9.05	\$24.36	NA
2-WIRE VOICE UNBUNDLED PBX LD TERMINAL SWITCHBOARD PORT	UEPXD	\$21.93	\$15.00	\$17.16	\$36.47	\$16.43	\$22.98	\$9.05	\$24.36	NA
2-WIRE VOICE UNBUNDLED PBX LD TERMINAL SWITCHBOARD IDD CAPABLE PORT	UEPXE	\$21.93	\$15.00	\$17.16	\$36.47	\$16.43	\$22.98	\$9.05	\$24.36	NA
2-WIRE VOICE UNBUNDLED 2-WAY PBX KENTUCKY ROOM AREA CALLING PORT WITHOUT LUD	UEPXF	NA	NA	NA	\$36.47	NA	NA	NA	NA	NA
2-WIRE VOICE UNBUNDLED PBX KENTUCKY LUD AREA CALLING PORT	UEPXG	NA	NA	NA	\$37.47	NA	NA	NA	NA	NA
2-WIRE VOICE UNBUNDLED PBX KENTUCKY PREMIUM CALLING PORT	UEPXH	NA	NA	NA	\$38.47	NA	NA	NA	NA	NA
2-WIRE VOICE UNBUNDLED 2-WAY KENTUCKY AREA CALLING PORT WITHOUT LUD	UEPXJ	NA	NA	NA	\$39.47	NA	NA	NA	NA	NA
2-WIRE VOICE UNBUNDLED 2-WAY PBX LOUISIANA LOCAL OPTIONAL CALLING PORT	UEPKK	NA	NA	NA	NA	\$16.43	NA	NA	NA	NA
2-WIRE VOICE UNBUNDLED 2-WAY PBX HOTEL/HOSPITAL ECONOMY ADMINISTRATIVE CALLING PORT	UEPXL	\$21.93	\$15.00	\$17.16	\$36.47	\$16.43	\$22.98	\$9.05	\$24.36	NA
2-WIRE VOICE UNBUNDLED 2-WAY PBX HOTEL/HOSPITAL ECONOMY ROOM CALLING PORT	URPXM	\$21.93	\$15.00	\$17.16	\$36.47	\$16.43	\$22.98	\$9.05	\$24.36	NA
2-WIRE VOICE UNBUNDLED 1-WAY OUTGOING PBX HOTEL/HOSPITAL ECONOMY ADMINIATRATIVE CALLING PORTTENNESSEE CALLING PORT	UEPXN	NA	NA	NA	NA	NA	NA	NA	NA	NA
2-WIRE VOICE UNBUNDLED 1-WAY OUTGOING PBX HOTEL/HOSPITAL DIACOUNT ROOM CALLING PORT	UEPXO	\$21.93	\$15.00	\$17.16	\$36.47	\$16.43	\$22.98	\$9.05	\$24.36	NA
2-WIRE VOICE UNBUNDLED 1-WAY OUTGOING PBX LOUISIANA LOCAL DISCOUNT CALLING PORT	UEPXP	NA	NA	NA	NA	\$16.43	NA	NA	NA	NA
2-WIRE VOICE UNBUNDLED 2-WAY PBX MISSISSIPPI LOCAL ECONOMY CALLING PORT	UEPXQ	NA	NA	NA	NA	NA	\$22.98	NA	NA	NA
2-WIRE VOICE UNBUNDLED 2-WAY PBX MISSISSIPPI LOCAL OPTIONAL CALLING PORT	UEPXR	NA	NA	NA	NA	NA	\$22.98	NA	NA	NA
2-WIRE VOICE UNBUNDLED 1-WAY OUTGOING PBXMEASURED PORT	UEPXS	\$21.93	\$15.00	\$17.16	\$36.47	\$16.43	\$22.98	\$9.05	\$24.36	NA
2-WIRE VOICE UNBUNDLED 2-WAY PBX SOUTH CAROLINA AREA PLUS CALLING PORT	UEPXT	NA	NA	NA	NA	NA	NA	NA	\$24.36	NA
2-WIRE VOICE UNBUNDLED PBX COLLIERVERVILLE & MEMPHIS CALLING PORT	UEPXU	NA	NA	NA	NA	NA	NA	NA	NA	NA
2-WIRE VOICE UNBUNDLED 2-WAY PBX TENNESSEE REGIONSERV CALLING PORT	UEPXV	NA	NA	NA	NA	NA	NA	NA	NA	NA
NRC - Disconnect Charge - 1st										
2 WIRE VOICE UNBUNDLED COMBINATION 2-WAY PBX TRUNK - Residence		\$6.21	NA	NA	NA	\$3.77	\$6.56	NA	NA	NA
LINE SIDE UNBUNDLED COMBINATION 2-WAY PBX TRUNK - BUSINESS		\$6.21	NA	NA	NA	\$3.77	\$6.56	NA	NA	NA
LINE SIDE UNBUNDLED OUTWARD PBX TRUNK - BUSINESS		\$6.21	NA	NA	NA	\$3.77	\$6.56	NA	NA	NA
LINE SIDE UNBUNDLED INCOMING PBX TRUNK - BUSINESS		\$6.21	NA	NA	NA	\$3.77	\$6.56	NA	NA	NA
LONG DISTANCE TERMINAL PBX TRUNK-BUSINESS		\$6.21	NA	NA	NA	\$3.77	\$6.56	NA	NA	NA
TN 2-WAY CALLING PLAN PBX TRUNK - BUSINESS		\$6.21	NA	NA	NA	\$3.77	\$6.56	NA	NA	NA
TN OUTWARD CALLING PLAN PBX TRUNK - BUSINESS		\$6.21	NA	NA	NA	\$3.77	\$6.56	NA	NA	NA
2-WIRE VOICE UNBUNDLED 2-WAY COMBINATION PBX ALABAMA CALLING PORT		\$6.21	NA	NA	NA	NA	NA	NA	NA	NA
2-WIRE VOICE UNBUNDLED 2-WAY COMBINATION PBX LOUISIANA CALLING PORT		NA	NA	NA	NA	\$3.77	NA	NA	NA	NA
2-WIRE VOICE UNBUNDLED PBX LD TERMINAL PORTS		\$6.21	NA	NA	NA	\$3.77	\$6.56	NA	NA	NA

BELLSOUTH/LEVEL 3 RATES
NETWORK ELEMENTS
AND OTHER SERVICES

DESCRIPTION		USOC	AL	FL	GA	KY	LA	MS	NC	SC	TN
	2-WIRE VOICE UNBUNDLED 2-WAY COMBINATION PBX TENNESSEE CALLING PORT		NA	NA	NA	NA	NA	NA	NA	NA	NA
	2-WIRE VOICE UNBUNDLED 1-WAY OUTGOING PBX TENNESSEE CALLING PORT		NA	NA	NA	NA	NA	NA	NA	NA	NA
	2-WIRE VOICE UNBUNDLED 2-WAY COMBINATION PBX USAGE PORT		\$6.21	NA	NA	NA	\$3.77	\$6.56	NA	NA	NA
	2-WIRE VOICE UNBUNDLED PBX TOLL TERMINAL HOTEL PORTS		\$6.21	NA	NA	NA	\$3.77	\$6.56	NA	NA	NA
	2-WIRE VOICE UNBUNDLED PBX LD DDD TERMINALS PORT		\$6.21	NA	NA	NA	\$3.77	\$6.56	NA	NA	NA
	2-WIRE VOICE UNBUNDLED PBX LD TERMINAL SWITCHBOARD PORT		\$6.21	NA	NA	NA	\$3.77	\$6.56	NA	NA	NA
	2-WIRE VOICE UNBUNDLED PBX LD TERMINAL SWITCHBOARD IDD CAPABLE PORT		\$6.21	NA	NA	NA	\$3.77	\$6.56	NA	NA	NA
	2-WIRE VOICE UNBUNDLED 2-WAY PBX KENTUCKY ROOM AREA CALLING PORT WITHOUT LUD		NA	NA	NA	NA	NA	NA	NA	NA	NA
	2-WIRE VOICE UNBUNDLED PBX KENTUCKY LUD AREA CALLING PORT		NA	NA	NA	NA	NA	NA	NA	NA	NA
	2-WIRE VOICE UNBUNDLED PBX KENTUCKY PREMIUM CALLING PORT		NA	NA	NA	NA	NA	NA	NA	NA	NA
	2-WIRE VOICE UNBUNDLED 2-WAY KENTUCKY AREA CALLING PORT WITHOUT LUD		NA	NA	NA	NA	NA	NA	NA	NA	NA
	2-WIRE VOICE UNBUNDLED 2-WAY PBX LOUISIANA LOCAL OPTIONAL CALLING PORT		NA	NA	NA	NA	\$3.77	NA	NA	NA	NA
	2-WIRE VOICE UNBUNDLED 2-WAY PBX HOTEL/HOSPITAL ECONOMY ADMINISTRATIVE CALLING PORT		\$6.21	NA	NA	NA	\$3.77	\$6.56	NA	NA	NA
	2-WIRE VOICE UNBUNDLED 2-WAY PBX HOTEL/HOSPITAL ECONOMY ROOM CALLING PORT		\$6.21	NA	NA	NA	\$3.77	\$6.56	NA	NA	NA
	2-WIRE VOICE UNBUNDLED 1-WAY OUTGOING PBX HOTEL/HOSPITAL ECONOMY ADMINISTRATIVE CALLING PORTTENNESSEE CALLING PORT		NA	NA	NA	NA	NA	NA	NA	NA	NA
	2-WIRE VOICE UNBUNDLED 1-WAY OUTGOING PBX HOTEL/HOSPITAL DISCOUNT ROOM CALLING PORT		\$6.21	NA	NA	NA	\$3.77	\$6.56	NA	NA	NA
	2-WIRE VOICE UNBUNDLED 1-WAY OUTGOING PBX LOUISIANA LOCAL DISCOUNT CALLING PORT		\$6.21	NA	NA	NA	\$3.77	\$6.56	NA	NA	NA
	2-WIRE VOICE UNBUNDLED 2-WAY PBX MISSISSIPPI LOCAL ECONOMY CALLING PORT		NA	NA	NA	NA	NA	\$6.56	NA	NA	NA
	2-WIRE VOICE UNBUNDLED 2-WAY PBX MISSISSIPPI LOCAL OPTIONAL CALLING PORT		NA	NA	NA	NA	NA	\$6.56	NA	NA	NA
	2-WIRE VOICE UNBUNDLED 1-WAY OUTGOING PBXMEASURED PORT		\$6.21	NA	NA	NA	\$3.77	\$6.56	NA	NA	NA
	2-WIRE VOICE UNBUNDLED 2-WAY PBX SOUTH CAROLINA AREA PLUS CALLING PORT		NA	NA	NA	NA	NA	NA	NA	NA	NA
	2-WIRE VOICE UNBUNDLED PBX COLLIERVILLE & MEMPHIS CALLING PORT		NA	NA	NA	NA	NA	NA	NA	NA	NA
	2-WIRE VOICE UNBUNDLED 2-WAY PBX TENNESSEE REGIONSERV CALLING PORT		NA	NA	NA	NA	NA	NA	NA	NA	NA
	NRC - Disconnect Charge - Add'l										
	2 WIRE VOICE UNBUNDLED COMBINATION 2-WAY PBX TRUNK - Residence		\$6.21	NA	NA	NA	\$3.77	\$6.56	NA	NA	NA
	LINE SIDE UNBUNDLED COMBINATION 2-WAY PBX TRUNK - BUSINESS		\$6.21	NA	NA	NA	\$3.77	\$6.56	NA	NA	NA
	LINE SIDE UNBUNDLED OUTWARD PBX TRUNK - BUSINESS		\$6.21	NA	NA	NA	\$3.77	\$6.56	NA	NA	NA
	LINE SIDE UNBUNDLED INCOMING PBX TRUNK - BUSINESS		\$6.21	NA	NA	NA	\$3.77	\$6.56	NA	NA	NA
	LONG DISTANCE TERMINAL PBX TRUNK-BUSINESS		\$6.21	NA	NA	NA	\$3.77	\$6.56	NA	NA	NA
	TN 2-WAY CALLING PLAN PBX TRUNK - BUSINESS		\$6.21	NA	NA	NA	\$3.77	\$6.56	NA	NA	NA
	TN OUTWARD CALLING PLAN PBX TRUNK - BUSINESS		\$6.21	NA	NA	NA	\$3.77	\$6.56	NA	NA	NA
	2-WIRE VOICE UNBUNDLED 2-WAY COMBINATION PBX ALABAMA CALLING PORT		\$6.21	NA	NA	NA	NA	NA	NA	NA	NA

BELLSOUTH/LEVEL 3 RATES
NETWORK ELEMENTS
AND OTHER SERVICES

DESCRIPTION	USOC	AL	FL	GA	KY	LA	MS	NC	SC	TN
2-WIRE VOICE UNBUNDLED 2-WAY COMBINATION PBX LOUISIANA CALLING PORT		NA	NA	NA	NA	\$3.77	NA	NA	NA	NA
2-WIRE VOICE UNBUNDLED PBX LD TERMINAL PORTS		\$6.21	NA	NA	NA	\$3.77	\$6.56	NA	NA	NA
2-WIRE VOICE UNBUNDLED 2-WAY COMBINATION PBX TENNESSEE CALLING PORT		NA	NA	NA	NA	NA	NA	NA	NA	NA
2-WIRE VOICE UNBUNDLED 1-WAY OUTGOING PBX TENNESSEE CALLING PORT		NA	NA	NA	NA	NA	NA	NA	NA	NA
2-WIRE VOICE UNBUNDLED 2-WAY COMBINATION PBX USAGE PORT		\$6.21	NA	NA	NA	\$3.77	\$6.56	NA	NA	NA
2-WIRE VOICE UNBUNDLED PBX TOLL TERMINAL HOTEL PORTS		\$6.21	NA	NA	NA	\$3.77	\$6.56	NA	NA	NA
2-WIRE VOICE UNBUNDLED PBX LD DDD TERMINALS PORT		\$6.21	NA	NA	NA	\$3.77	\$6.56	NA	NA	NA
2-WIRE VOICE UNBUNDLED PBX LD TERMINAL SWITCHBOARD PORT		\$6.21	NA	NA	NA	\$3.77	\$6.56	NA	NA	NA
2-WIRE VOICE UNBUNDLED PBX LD TERMINAL SWITCHBOARD IDD CAPABLE PORT		\$6.21	NA	NA	NA	\$3.77	\$6.56	NA	NA	NA
2-WIRE VOICE UNBUNDLED 2-WAY PBX KENTUCKY ROOM AREA CALLING PORT WITHOUT LUD		NA	NA	NA	NA	NA	NA	NA	NA	NA
2-WIRE VOICE UNBUNDLED PBX KENTUCKY LUD AREA CALLING PORT		NA	NA	NA	NA	NA	NA	NA	NA	NA
2-WIRE VOICE UNBUNDLED PBX KENTUCKY PREMIUM CALLING PORT		NA	NA	NA	NA	NA	NA	NA	NA	NA
2-WIRE VOICE UNBUNDLED 2-WAY KENTUCKY AREA CALLING PORT WITHOUT LUD		NA	NA	NA	NA	NA	NA	NA	NA	NA
2-WIRE VOICE UNBUNDLED 2-WAY PBX LOUISIANA LOCAL OPTIONAL CALLING PORT		NA	NA	NA	NA	\$3.77	NA	NA	NA	NA
2-WIRE VOICE UNBUNDLED 2-WAY PBX HOTEL/HOSPITAL ECONOMY ADMINISTRATIVE CALLING PORT		\$6.21	NA	NA	NA	\$3.77	\$6.56	NA	NA	NA
2-WIRE VOICE UNBUNDLED 2-WAY PBX HOTEL/HOSPITAL ECONOMY ROOM CALLING PORT		\$6.21	NA	NA	NA	\$3.77	\$6.56	NA	NA	NA
2-WIRE VOICE UNBUNDLED 1-WAY OUTGOING PBX HOTEL/HOSPITAL ECONOMY ADMINISTRATIVE CALLING PORT TENNESSEE CALLING PORT		NA	NA	NA	NA	NA	NA	NA	NA	NA
2-WIRE VOICE UNBUNDLED 1-WAY OUTGOING PBX HOTEL/HOSPITAL DISCOUNT ROOM CALLING PORT		\$6.21	NA	NA	NA	\$3.77	\$6.56	NA	NA	NA
2-WIRE VOICE UNBUNDLED 1-WAY OUTGOING PBX LOUISIANA LOCAL DISCOUNT CALLING PORT		\$6.21	NA	NA	NA	\$3.77	\$6.56	NA	NA	NA
2-WIRE VOICE UNBUNDLED 2-WAY PBX MISSISSIPPI LOCAL ECONOMY CALLING PORT		NA	NA	NA	NA	NA	\$6.56	NA	NA	NA
2-WIRE VOICE UNBUNDLED 2-WAY PBX MISSISSIPPI LOCAL OPTIONAL CALLING PORT		NA	NA	NA	NA	NA	\$6.56	NA	NA	NA
2-WIRE VOICE UNBUNDLED 1-WAY OUTGOING PBX MEASURED PORT		\$6.21	NA	NA	NA	\$3.77	\$6.56	NA	NA	NA
2-WIRE VOICE UNBUNDLED 2-WAY PBX SOUTH CAROLINA AREA PLUS CALLING PORT		NA	NA	NA	NA	NA	NA	NA	NA	NA
2-WIRE VOICE UNBUNDLED PBX COLLIERVILLE & MEMPHIS CALLING PORT		NA	NA	NA	NA	NA	NA	NA	NA	NA
2-WIRE VOICE UNBUNDLED 2-WAY PBX TENNESSEE REGIONSERV CALLING PORT		NA	NA	NA	NA	NA	NA	NA	NA	NA
NRC - Incremental Charge - Manual Service Order - 1st	SOMAN	\$27.37	NA	\$18.94	NA	\$18.14	\$25.52	\$26.94	\$41.86	NA
NRC - Incremental Charge - Manual Service Order - Add'l	SOMAN	\$12.97	NA	\$8.42	NA	\$8.06	\$11.34	\$12.76	\$14.46	NA
NRC - Incremental Charge - Manual Service Order - Disconnect - 1st	SOMAN	\$17.77	NA	NA	NA	\$8.94	\$16.06	NA	NA	NA
NRC - Incremental Charge - Manual Service Order - Disconnect - Add'l	SOMAN	\$0.48	NA	NA	NA	NA	NA	NA	NA	NA
2-Wire Analog Line Port (PBX) including all available features, per month	UEPPC	NA	NA	NA	NA	NA	NA	NA	\$8.67	NA
NRC - 1st	UEPPC	NA	NA	NA	NA	NA	NA	NA	\$60.60	NA

BELLSOUTH/LEVEL 3 RATES
NETWORK ELEMENTS
AND OTHER SERVICES

DESCRIPTION	USOC	AL	FL	GA	KY	LA	MS	NC	SC	TN
NRC - Add'l	UEPPC	NA	NA	NA	NA	NA	NA	NA	\$60.60	NA
NRC - Incremental Charge - Manual Service Order - 1st	SOMAN	NA	NA	NA	NA	NA	NA	NA	\$41.86	NA
NRC - Incremental Charge - Manual Service Order - Add'l	SOMAN	NA	NA	NA	NA	NA	NA	NA	\$14.46	NA
2-Wire Analog Line Port (PBX) including three available features, per month	UEPPC	NA	NA	NA	NA	NA	NA	NA	\$5.38	NA
NRC - 1st	UEPPC	NA	NA	NA	NA	NA	NA	NA	\$28.89	NA
NRC - Add'l	UEPPC	NA	NA	NA	NA	NA	NA	NA	\$28.89	NA
NRC - Incremental Charge - Manual Service Order - 1st	SOMAN	NA	NA	NA	NA	NA	NA	NA	\$41.86	NA
NRC - Incremental Charge - Manual Service Order - Add'l	SOMAN	NA	NA	NA	NA	NA	NA	NA	\$14.46	NA
2-Wire Analog Hunting, per line per month	HTGUX	See features	NA	NA	\$0.29	NA	See features	NA	See features	NA
NRC - 1st	HTGUX	See features	NA	NA	\$2.14	NA	See features	NA	See features	NA
NRC - Add'l	HTGUX	See features	NA	NA	\$2.14	NA	See features	NA	See features	NA
Coin Port, per month		\$2.34	NA	\$2.05	\$3.04	\$2.50	\$2.32	NA	\$2.77	\$1.90
NRC - 1st		\$21.93	NA	\$17.16	\$40.71	\$16.43	\$22.98	NA	\$24.75	BST GSST A4.3.1
NRC - Add'l		\$21.93	NA	\$17.16	\$40.71	\$16.43	\$22.98	NA	\$24.75	BST GSST A4.3.1
NRC - Disconnect Charge - 1st		\$5.21	NA	NA	NA	\$4.15	\$6.56	NA	NA	NA
NRC - Disconnect Charge - Add'l		\$5.21	NA	NA	NA	\$4.15	\$6.56	NA	NA	NA
NRC - Incremental Charge - Manual Service Order - 1st	SOMAN	\$25.93	NA	\$18.94	NA	\$18.14	\$25.52	NA	\$43.48	NA
NRC - Incremental Charge - Manual Service Order - Add'l	SOMAN	\$12.97	NA	\$8.42	NA	\$8.06	\$11.34	NA	\$14.57	NA
NRC - Incremental Charge - Manual Service Order - Disconnect - 1st	SOMAN	\$16.33	NA	NA	NA	\$9.86	\$16.06	NA	NA	NA
NRC - Incremental Charge - Manual Service Order - Disconnect - Add'l	SOMAN	\$0.48	NA	NA	NA	NA	NA	NA	NA	NA
4-Wire Coin Port, per month		NA	NA	NA	NA	NA	NA	\$2.59	NA	NA
NRC - 1st		NA	NA	NA	NA	NA	NA	\$21.60	NA	NA
NRC - Add'l		NA	NA	NA	NA	NA	NA	\$21.60	NA	NA
NRC - Disconnect Charge - 1st		NA	NA	NA	NA	NA	NA	NA	NA	NA
NRC - Disconnect Charge - Add'l		NA	NA	NA	NA	NA	NA	NA	NA	NA
NRC - Incremental Charge - Manual Service Order - 1st		NA	NA	NA	NA	NA	NA	\$26.94	NA	NA
NRC - Incremental Charge - Manual Service Order - Add'l		NA	NA	NA	NA	NA	NA	\$12.76	NA	NA
NRC - Incremental Charge - Manual Service Order - Disconnect - 1st		NA	NA	NA	NA	NA	NA	NA	NA	NA
NRC - Incremental Charge - Manual Service Order - Disconnect - Add'l		NA	NA	NA	NA	NA	NA	NA	NA	NA
VERTICAL FEATURES										
Local Switching Features offered with Port, Per month	N/A	NA	No add'l charge	NA	No add'l charge	\$8.28	NA	NA	See above	NA
Three-Way Calling, per month		\$1.12	NA	NA	NA	NA	\$1.32	\$0.89	\$1.10	NA
NRC		\$1.03	NA	NA	NA	NA	\$1.02	\$1.51	\$1.51	NA
NRC - Disconnect		\$0.55	NA	NA	NA	NA	\$0.5466	NA	NA	NA
Customer Changeable Speed Calling, per month		\$0.08	NA	NA	NA	NA	\$0.0755	\$0.17	\$0.1247	NA
NRC		\$1.03	NA	NA	NA	NA	\$1.02	\$1.51	\$1.51	NA
NRC - Disconnect		\$0.55	NA	NA	NA	NA	\$0.5466	NA	NA	NA
Call Waiting		\$0.03	NA	NA	NA	NA	\$0.033	\$0.09	\$0.0665	NA
NRC		\$1.03	NA	NA	NA	NA	\$1.02	\$1.51	\$1.51	NA
NRC - Disconnect		\$0.55	NA	NA	NA	NA	\$0.5466	NA	NA	NA
Remote Activation of Call Forwarding, per month		\$0.18	NA	NA	NA	NA	\$0.4859	\$0.85	\$0.3743	NA
NRC		\$1.03	NA	NA	NA	NA	\$1.02	\$1.51	\$1.51	NA
NRC - Disconnect		\$0.55	NA	NA	NA	NA	\$0.5466	NA	NA	NA
Cancel Call Waiting, per month		\$0.01	NA	NA	NA	NA	\$0.0082	\$0.01	\$0.0099	NA
NRC		\$1.03	NA	NA	NA	NA	\$1.02	\$1.51	\$1.51	NA
NRC - Disconnect		\$0.55	NA	NA	NA	NA	\$0.5466	NA	NA	NA
Automatic Callback, per month		\$0.29	NA	NA	NA	NA	\$0.9977	\$0.66	\$0.8015	NA
NRC		\$1.03	NA	NA	NA	NA	\$1.02	\$1.51	\$1.51	NA
NRC - Disconnect		\$0.55	NA	NA	NA	NA	\$0.5466	NA	NA	NA

BELLSOUTH/LEVEL 3 RATES
NETWORK ELEMENTS
AND OTHER SERVICES

DESCRIPTION	USOC	AL	FL	GA	KY	LA	MS	NC	SC	TN
Automatic Recall, per month		\$0.28	NA	NA	NA	NA	\$0.3164	\$0.29	\$0.3102	NA
NRC		\$1.03	NA	NA	NA	NA	\$1.02	\$1.51	\$1.51	NA
NRC - Disconnect		\$0.55	NA	NA	NA	NA	\$0.5466	NA	NA	NA
Calling Number Delivery, per month		\$0.22	NA	NA	NA	NA	\$0.1817	\$0.33	\$0.3272	NA
NRC		\$1.03	NA	NA	NA	NA	\$1.02	\$1.51	\$1.51	NA
NRC - Disconnect		\$0.55	NA	NA	NA	NA	\$0.5466	NA	NA	NA
Calling Number Delivery Blocking, per month		\$1.17	NA	NA	NA	NA	\$0.9913	\$0.02	\$0.3684	NA
NRC		\$1.03	NA	NA	NA	NA	\$1.02	\$1.51	\$1.51	NA
NRC - Disconnect		\$0.55	NA	NA	NA	NA	\$0.5466	NA	NA	NA
Customer Originated Trace, per month		\$0.14	NA	NA	NA	NA	\$0.1918	\$0.14	\$0.1402	NA
NRC		\$1.03	NA	NA	NA	NA	\$1.02	\$1.51	\$1.51	NA
NRC - Disconnect		\$0.55	NA	NA	NA	NA	\$0.5466	NA	NA	NA
Selective Call Rejection, per month		\$0.13	NA	NA	NA	NA	\$0.1721	\$0.13	\$0.1528	NA
NRC		\$1.03	NA	NA	NA	NA	\$1.02	\$1.51	\$1.51	NA
NRC - Disconnect		\$0.55	NA	NA	NA	NA	\$0.5466	NA	NA	NA
Selective Call Forwarding, per month		\$0.05	NA	NA	NA	NA	\$0.1050	\$0.28	\$0.1287	NA
NRC		\$1.03	NA	NA	NA	NA	\$1.02	\$1.51	\$1.51	NA
NRC - Disconnect		\$0.55	NA	NA	NA	NA	\$0.5466	NA	NA	NA
Selective Call Acceptance, per month		\$0.29	NA	NA	NA	NA	\$0.4010	\$0.33	\$0.3283	NA
NRC		\$1.03	NA	NA	NA	NA	\$1.02	\$1.51	\$1.51	NA
NRC - Disconnect		\$0.55	NA	NA	NA	NA	\$0.5466	NA	NA	NA
Multiline Hunt Service (Rotary)										
Service per line, (in addition to port) , per month		\$0.11	NA	NA	NA	NA	\$0.1271	\$0.14	\$0.1301	NA
NRC		\$1.03	NA	NA	NA	NA	\$1.02	\$1.51	\$1.51	NA
NRC - Disconnect		\$0.55	NA	NA	NA	NA	\$0.5466	NA	NA	NA
Call Forwarding Variable, per month		\$0.05	NA	NA	NA	NA	\$0.0474	\$0.10	\$0.0768	NA
NRC		\$1.03	NA	NA	NA	NA	\$1.02	\$1.51	\$1.51	NA
NRC - Disconnect		\$0.55	NA	NA	NA	NA	\$0.5466	NA	NA	NA
Call Forwarding Busy Line, per month		\$0.03	NA	NA	NA	NA	\$0.0279	\$0.08	\$0.0603	NA
NRC		\$1.03	NA	NA	NA	NA	\$1.02	\$1.51	\$1.51	NA
NRC - Disconnect		\$0.55	NA	NA	NA	NA	\$0.5466	NA	NA	NA
Call Forwarding Don't Answer All Calls, per month		\$0.03	NA	NA	NA	NA	\$0.0308	\$0.09	\$0.0655	NA
NRC		\$1.03	NA	NA	NA	NA	\$1.02	\$1.51	\$1.51	NA
NRC - Disconnect		\$0.55	NA	NA	NA	NA	\$0.5466	NA	NA	NA
Remote Call Forwarding, per month		\$1.36	NA	NA	NA	NA	\$1.47	\$0.95	\$1.41	NA
NRC		\$1.03	NA	NA	NA	NA	\$1.02	\$1.51	\$1.51	NA
NRC - Disconnect		\$0.55	NA	NA	NA	NA	\$0.5466	NA	NA	NA
Call Transfer, per month		\$0.12	NA	NA	NA	NA	\$0.1404	\$0.14	\$0.1392	NA
NRC		\$1.03	NA	NA	NA	NA	\$1.02	\$1.51	\$1.51	NA
NRC - Disconnect		\$0.55	NA	NA	NA	NA	\$0.5466	NA	NA	NA
Call Hold, per month		\$0.03	NA	NA	NA	NA	\$0.0190	\$0.15	\$0.0677	NA
NRC		\$1.03	NA	NA	NA	NA	\$1.02	\$1.51	\$1.51	NA
NRC - Disconnect		\$0.55	NA	NA	NA	NA	\$0.5466	NA	NA	NA
Toll Restricted Service, per month		\$0.04	NA	NA	NA	NA	\$0.0387	\$0.10	\$0.0743	NA
NRC		\$1.03	NA	NA	NA	NA	\$1.02	\$1.51	\$1.51	NA
NRC - Disconnect		\$0.55	NA	NA	NA	NA	\$0.5466	NA	NA	NA
Message Waiting Indicator – Stutter Dial Tone, per month		\$0.03	NA	NA	NA	NA	\$0.0356	\$0.03	\$0.0318	NA
NRC		\$1.03	NA	NA	NA	NA	\$1.02	\$1.51	\$1.51	NA
NRC - Disconnect		\$0.55	NA	NA	NA	NA	\$0.5466	NA	NA	NA
Anonymous Call Rejection, per month		\$0.93	NA	NA	NA	NA	\$0.9519	\$1.29	\$1.13	NA
NRC		\$1.03	NA	NA	NA	NA	\$1.02	\$1.51	\$1.51	NA
NRC - Disconnect		\$0.55	NA	NA	NA	NA	\$0.5466	NA	NA	NA
Shared Call Appearances of a DN, per month		\$0.41	NA	NA	NA	NA	\$0.5015	\$0.29	\$0.3513	NA
NRC		\$1.03	NA	NA	NA	NA	\$1.02	\$1.47	\$1.47	NA
NRC - Disconnect		\$0.55	NA	NA	NA	NA	\$0.5466	NA	NA	NA

BELLSOUTH/LEVEL 3 RATES
NETWORK ELEMENTS
AND OTHER SERVICES

DESCRIPTION	USOC	AL	FL	GA	KY	LA	MS	NC	SC	TN
Multiple Call Appearances, per month		\$0.09	NA	NA	NA	NA	\$0.0932	\$0.07	\$0.0891	NA
NRC		\$1.03	NA	NA	NA	NA	\$1.02	\$1.47	\$1.47	NA
NRC - Disconnect		\$0.55	NA	NA	NA	NA	\$0.5466	NA	NA	NA
ISDN Bridged Call Exclusion, per month		\$0.00	NA	NA	NA	NA	\$0.0013	\$0.0011	\$0.0013	NA
NRC		\$1.03	NA	NA	NA	NA	\$1.02	\$1.47	\$1.47	NA
NRC - Disconnect		\$0.55	NA	NA	NA	NA	\$0.5466	NA	NA	NA
Call by Call Access, per month		\$28.29	NA	NA	NA	NA	\$50.89	\$19.83	\$0.3621	NA
NRC		\$28.94	NA	NA	NA	NA	\$28.61	\$33.33	\$33.36	NA
NRC - Disconnect		\$5.22	NA	NA	NA	NA	\$5.16	NA	NA	NA
Privacy Release, per month		\$0.01	NA	NA	NA	NA	\$0.0030	\$0.0041	\$0.0116	NA
NRC		\$1.03	NA	NA	NA	NA	\$1.02	\$1.51	\$1.51	NA
NRC - Disconnect		\$0.55	NA	NA	NA	NA	\$0.5466	NA	NA	NA
Multi Appearance Directory Number Calls, per month		\$0.10	NA	NA	NA	NA	\$0.1115	\$0.13	\$0.1048	NA
NRC		\$1.03	NA	NA	NA	NA	\$1.02	\$1.51	\$1.51	NA
NRC - Disconnect		\$0.55	NA	NA	NA	NA	\$0.5466	NA	NA	NA
Make Set Busy, per month		\$0.01	NA	NA	NA	NA	\$0.0013	\$0.0020	\$0.0101	NA
NRC		\$1.03	NA	NA	NA	NA	\$1.02	\$1.51	\$1.51	NA
NRC - Disconnect		\$0.55	NA	NA	NA	NA	\$0.5466	NA	NA	NA
Teen Service (Res. Dist. Alerting Service), per month		\$0.15	NA	NA	NA	NA	\$0.1071	\$0.26	\$0.2149	NA
NRC		\$1.03	NA	NA	NA	NA	\$1.02	\$1.51	\$1.51	NA
NRC - Disconnect		\$0.55	NA	NA	NA	NA	\$0.5466	NA	NA	NA
Code Restriction and Diversion, per month		\$0.04	NA	NA	NA	NA	\$0.0464	\$0.09	\$0.0708	NA
NRC		\$1.03	NA	NA	NA	NA	\$1.02	\$1.51	\$1.51	NA
NRC - Disconnect		\$0.55	NA	NA	NA	NA	\$0.5466	NA	NA	NA
Call Park, per month		\$0.04	NA	NA	NA	NA	\$0.0443	\$0.09	\$0.0694	NA
NRC		\$1.03	NA	NA	NA	NA	\$1.02	\$1.51	\$1.51	NA
NRC - Disconnect		\$0.55	NA	NA	NA	NA	\$0.5466	NA	NA	NA
Automatic Line, per month		\$0.09	NA	NA	NA	NA	\$0.1111	\$0.14	\$0.1179	NA
NRC		\$1.03	NA	NA	NA	NA	\$1.02	\$1.51	\$1.51	NA
NRC - Disconnect		\$0.55	NA	NA	NA	NA	\$0.5466	NA	NA	NA
2-WIRE ISDN BRI FEATURES										
Shared Primary Number-First Appr On Each Add'l Terminal	DS1FJ	TBD	TBD	TBD	TBD	TBD	TBD	TBD	TBD	TBD
Secondary Only Dn (Shared/Non-Shared) First Appearance	LLDSF	TBD	TBD	TBD	TBD	TBD	TBD	TBD	TBD	TBD
Shared Secondary Only Dn-First Appr On Each Add'l Term	DS1F1	TBD	TBD	TBD	TBD	TBD	TBD	TBD	TBD	TBD
Shared Non-ISDN DN	DOE	TBD	TBD	TBD	TBD	TBD	TBD	TBD	TBD	TBD
Privacy Release	DS1FU	TBD	TBD	TBD	TBD	TBD	TBD	TBD	TBD	TBD
Manual Exclusion	DS1FM	TBD	TBD	TBD	TBD	TBD	TBD	TBD	TBD	TBD
Call Forwarding Variable-Voice Or Voice/Data	LLNCV	TBD	TBD	TBD	TBD	TBD	TBD	TBD	TBD	TBD
Call Forwarding Variable - Data	LLQCD	TBD	TBD	TBD	TBD	TBD	TBD	TBD	TBD	TBD
Call Forwarding Variable - Feature Button - Voice	GJXCF	TBD	TBD	TBD	TBD	TBD	TBD	TBD	TBD	TBD
Call Forwarding Variable - Feature Button - Data	LLPCD	TBD	TBD	TBD	TBD	TBD	TBD	TBD	TBD	TBD
Call Forwarding Busy Line - Voice Or Voice/Data	LLQCV	TBD	TBD	TBD	TBD	TBD	TBD	TBD	TBD	TBD
Call Forwarding Busy Line - Data	LLRCD	TBD	TBD	TBD	TBD	TBD	TBD	TBD	TBD	TBD
Call Frwdng Busy Line-Prgrmmbl-Voice Or Voice/Data	M6AVA	TBD	TBD	TBD	TBD	TBD	TBD	TBD	TBD	TBD
Call Forwarding Busy Line - Programmable - Data	M6ADF	TBD	TBD	TBD	TBD	TBD	TBD	TBD	TBD	TBD
Call Forwarding Don't Answer - Voice Or Voice/Data	LLSCV	TBD	TBD	TBD	TBD	TBD	TBD	TBD	TBD	TBD
Call Forwarding Don't Answer - Data	LLUCD	TBD	TBD	TBD	TBD	TBD	TBD	TBD	TBD	TBD
Call Forwdng Don't Answer-Prgrmmble Voice Or Voice/Data	M6BVA	TBD	TBD	TBD	TBD	TBD	TBD	TBD	TBD	TBD
Call Forwarding Don't Answer - Programmable - Data	M6BDF	TBD	TBD	TBD	TBD	TBD	TBD	TBD	TBD	TBD
Call Frwdng Multiple Simultaneous - Voice Or Voice/Data	M6CV5	TBD	TBD	TBD	TBD	TBD	TBD	TBD	TBD	TBD
Call Forwarding Multiple Simultaneous - Data	M6CD5	TBD	TBD	TBD	TBD	TBD	TBD	TBD	TBD	TBD
Conference, Drop, Hold And Transfer	DS1FN	TBD	TBD	TBD	TBD	TBD	TBD	TBD	TBD	TBD
Six-Way Conference, Drop, Hold And Transfer	LLY6P	TBD	TBD	TBD	TBD	TBD	TBD	TBD	TBD	TBD
Multi-Line Hunt Group - Voice Or Voice/Data	HTG	TBD	TBD	TBD	TBD	TBD	TBD	TBD	TBD	TBD

BELLSOUTH/LEVEL 3 RATES
NETWORK ELEMENTS
AND OTHER SERVICES

DESCRIPTION	USOC	AL	FL	GA	KY	LA	MS	NC	SC	TN
Multi-Line Hunt Group – Data	HTGSD	TBD	TBD	TBD	TBD	TBD	TBD	TBD	TBD	TBD
Speed Calling	LLZSU	TBD	TBD	TBD	TBD	TBD	TBD	TBD	TBD	TBD
Visual Message Waiting Indicator	LLAVP	TBD	TBD	TBD	TBD	TBD	TBD	TBD	TBD	TBD
Audible Message Waiting Indicator	MWW	TBD	TBD	TBD	TBD	TBD	TBD	TBD	TBD	TBD
Additional Call Appearance, PDN Or DN	DS1FG	TBD	TBD	TBD	TBD	TBD	TBD	TBD	TBD	TBD
Call Tracing	NST	TBD	TBD	TBD	TBD	TBD	TBD	TBD	TBD	TBD
Call Return	NSS	TBD	TBD	TBD	TBD	TBD	TBD	TBD	TBD	TBD
Preferred Call Forwarding	NCE	TBD	TBD	TBD	TBD	TBD	TBD	TBD	TBD	TBD
Call Block	NSY	TBD	TBD	TBD	TBD	TBD	TBD	TBD	TBD	TBD
Repeat Dialing	NSQ	TBD	TBD	TBD	TBD	TBD	TBD	TBD	TBD	TBD
Per Line Blocking For Agencies/Law Enforcement	NOB	TBD	TBD	TBD	TBD	TBD	TBD	TBD	TBD	TBD
Per Line Blocking For Non-Pub Customers	NOBNN	TBD	TBD	TBD	TBD	TBD	TBD	TBD	TBD	TBD
Per Line Blocking For General Public	NOBPC	TBD	TBD	TBD	TBD	TBD	TBD	TBD	TBD	TBD
Per Line Blocking For Non-Pub, And Non-Listed Customer	NOBPP	TBD	TBD	TBD	TBD	TBD	TBD	TBD	TBD	TBD
Per Line Blocking For Non-Pub Customers	NOBNP	TBD	TBD	TBD	TBD	TBD	TBD	TBD	TBD	TBD
Per Line Blocking For Non-Pub Customers	NOBNR	TBD	TBD	TBD	TBD	TBD	TBD	TBD	TBD	TBD
Call Return Denial Of, Per Activation	BCR	TBD	TBD	TBD	TBD	TBD	TBD	TBD	TBD	TBD
Repeat Dialing, Denial Of, Per Activation	BRD	TBD	TBD	TBD	TBD	TBD	TBD	TBD	TBD	TBD
Automatic Line/Direct Connect	M6GN9	TBD	TBD	TBD	TBD	TBD	TBD	TBD	TBD	TBD
Make Set Busy	M6MPD	TBD	TBD	TBD	TBD	TBD	TBD	TBD	TBD	TBD
Selective Call Acceptance	M6K16	TBD	TBD	TBD	TBD	TBD	TBD	TBD	TBD	TBD
Call Park/Call Retrieve	M6HP6	TBD	TBD	TBD	TBD	TBD	TBD	TBD	TBD	TBD
Call Transfer System Exception	M6QTD	TBD	TBD	TBD	TBD	TBD	TBD	TBD	TBD	TBD
Make Set Busy – Intragroup	M6MGD	TBD	TBD	TBD	TBD	TBD	TBD	TBD	TBD	TBD
All Customized Code Restrictions	CREX+	TBD	TBD	TBD	TBD	TBD	TBD	TBD	TBD	TBD
Additional Listings	CLT	TBD	TBD	TBD	TBD	TBD	TBD	TBD	TBD	TBD
Additional Listing No Rate	FLT	TBD	TBD	TBD	TBD	TBD	TBD	TBD	TBD	TBD
Cross Reference Listing	LLT	TBD	TBD	TBD	TBD	TBD	TBD	TBD	TBD	TBD
Non-Pub Listing No Rate	NP3	TBD	TBD	TBD	TBD	TBD	TBD	TBD	TBD	TBD
Non-List Listing	NLT	TBD	TBD	TBD	TBD	TBD	TBD	TBD	TBD	TBD
Non-List Listing No Rate	NLE	TBD	TBD	TBD	TBD	TBD	TBD	TBD	TBD	TBD
Alternate Call Listing	FNA	TBD	TBD	TBD	TBD	TBD	TBD	TBD	TBD	TBD
Manual Service Order Charge	SOMAN	TBD	TBD	TBD	TBD	TBD	TBD	TBD	TBD	TBD
All Selective Class Of Call Screening	SRG++	TBD	TBD	TBD	TBD	TBD	TBD	TBD	TBD	TBD
ISDN Message Waiting Indication-Lamp, per month										
NRC		\$0.01	NA	NA	NA	NA	\$0.0105	\$0.0107	\$0.0138	NA
NRC - Disconnect		\$1.03	NA	NA	NA	NA	\$1.02	\$1.47	\$1.47	NA
NRC - Disconnect		\$0.55	NA	NA	NA	NA	\$0.5466	NA	NA	NA
ISDN Feature Function Buttons										
NRC		NA	NA	NA	NA	NA	NA	NA	NA	NA
NRC - Disconnect		\$1.03	NA	NA	NA	NA	\$1.02	\$1.51	\$1.51	NA
NRC - Disconnect		\$0.55	NA	NA	NA	NA	\$0.5466	NA	NA	NA
Subsequent Ordering Charge – (per order, per line)										
NRC - Electronic - 1st		NA	NA	NA	NA	NA	NA	NA	NA	NA
NRC - Electronic - Add'l		\$2.88	NA	NA	NA	NA	\$2.84	\$5.42	\$1.36	NA
NRC - Manual - 1st		\$0.96	NA	NA	NA	NA	\$0.95	\$0.95	\$0.71	NA
NRC - Manual - Add'l		\$4.80	NA	NA	NA	NA	\$4.73	\$1.89	\$7.35	NA
NRC - Manual - Add'l		\$0.96	NA	NA	NA	NA	\$0.95	NA	\$0.95	NA
NRC - Disconnect		\$2.88	NA	NA	NA	NA	\$2.84	NA	NA	NA
End Office Switching (Port Usage)										
End Office Switching Function, per mou	N/A	\$0.0018	\$0.0175	\$0.0016333	\$0.002562	\$0.0021	\$0.0023771	\$0.0017000	\$0.0019295	\$0.0019
End Office Switching Function, add'l mou (5)	N/A	NA	\$0.005	NA	NA	NA	NA	NA	NA	NA
End Office Interoffice Trunk Port—Shared, per mou	N/A	\$0.0002	NA	\$0.0001564	NA	\$0.0002	\$0.0001927	NA	\$0.0002581	NA
Tandem Switching (Port Usage) (Local or Access Tandem)										
Tandem Switching Function per mou	N/A	\$0.00063	\$0.00029	\$0.0006757	\$0.001096	\$0.0008	\$0.0007834	\$0.0009	\$0.0006843	\$0.000676
Tandem Interoffice Trunk Port - Shared per mou			NA	\$0.0002126	NA	\$0.0003	\$0.0002834	NA	\$0.0004034	NA

BELLSOUTH/LEVEL 3 RATES
 NETWORK ELEMENTS
 AND OTHER SERVICES

DESCRIPTION		USOC	AL	FL	GA	KY	LA	MS	NC	SC	TN
NOTES:											
1	Port rate includes all available features.										
2	Transmission/usage charges associated with POTS circuit switched usage will also apply to circuit switched voice and/or circuit switched data transmission by B-Channels associated with 2-wire ISDN ports.										
3	Access to B Channel or D Channel Packet capabilities will be available only through BFR/New Business Request Process. Rates for the packet capabilities will be determined via the Bona Fide Request/New Business Request Process.										
4	This rate element is for those states which have a specific rate for User Profile per B Channel.										
5	This rate element is for use in those states with a different rate for additional minutes of use.										

BELLSOUTH/LEVEL 3 RATES
NETWORK ELEMENTS
AND OTHER SERVICES

DESCRIPTION	USOC	AL	FL	GA	KY	LA	MS	NC	SC	TN
INTEROFFICE TRANSPORT										
Common (Shared) Transport										
Common (Shared) Transport per mile per mou	N/A	\$0.00001	\$0.000012	\$0.000008	\$0.0000049	\$0.0000083	\$0.0000091	\$0.00001	\$0.0000121	\$0.00004
Common (Shared) Transport Facilities Termination per mou	N/A	\$0.00045	\$0.0005	\$0.0004152	\$0.000426	\$0.00047	\$0.0004281	\$0.00034	\$0.0004672	\$0.00036
Interoffice Channel - Dedicated Transport - VG										
Interoffice Transport - Dedicated - 2-wire VG										
2-Wire VG - per mile per month	1L5XX	\$0.03	\$0.0100	\$0.02	\$0.03	\$0.04	\$0.03	\$0.03	\$0.04	\$0.02
2-Wire VG - Facility Termination per month	U1TV2	\$18.49	\$26.72	\$17.07	\$27.66	\$19.10	\$21.33	\$18.01	\$21.42	\$18.33
NRC - 2-wire VG - Facility Termination -1st	U1TV2	\$107.11	\$81.73	\$79.61	\$142.31	\$76.20	\$106.72	\$137.48	\$136.44	\$55.39
NRC - 2-wire VG - Facility Termination - Add'l	U1TV2	\$48.27	\$55.26	\$36.08	\$56.21	\$34.54	\$48.83	\$52.58	\$51.37	\$17.37
NRC - 2-wire VG -Facility Termination - Disconnect Charge -1st	U1TV2	\$37.16	\$31.26	NA	NA	\$28.03	\$38.05	NA	NA	\$27.96
NRC - 2-wire VG - Facility Termination - Disconnect Charge -Add'l	U1TV2	\$5.88	\$12.88	NA	NA	\$5.37	\$7.23	NA	NA	\$3.51
NRC - Manual Svc Order, per LSR	SOMAN	NA	\$21.73	NA	\$19.99	NA	NA	NA	NA	\$19.99
NRC - Manual Svc Order, per LSR disconnect	SOMAN	NA	\$3.87	NA	NA	NA	NA	NA	NA	NA
NRC - Electronic Svc Order, per LSR	SOMEK	\$3.50	\$2.77	\$3.50	\$3.50	\$3.50	\$3.50	\$3.50	\$3.50	\$3.50
NRC - Electronic Svc Order, per LSR disconnect	SOMEK	NA	\$0.43	NA	NA	NA	NA	NA	NA	NA
NRC - 2-wire VG - Incremental Charge--Manual Svc Order - 1st	SOMAN	\$27.37	NA	\$18.94	NA	\$18.14	\$25.52	\$38.07	\$39.63	NA
NRC - 2-wire VG - Incremental Charge--Manual Svc Order - Add'l	SOMAN	\$27.57	NA	\$18.94	NA	\$18.14	\$25.52	\$38.07	\$39.63	NA
NRC - 2-wire VG - Incremental Charge--Manual Svc Order-Disconnect--1st	SOMAN	\$12.97	NA	NA	NA	\$8.06	\$11.34	NA	NA	NA
NRC - 2-wire VG - Incremental Charge--Manual Svc Order-Disconnect--Add'l	SOMAN	\$12.97	NA	NA	NA	\$8.06	\$11.34	NA	NA	NA
Interoffice Transport - Dedicated - 4-wire VG										
4-Wire VG - per mile per month	1L5XX	NA	\$0.0100	NA	NA	NA	NA	NA	NA	NA
4-Wire VG - Facility Termination per month	U1TV4	NA	\$23.82	NA	NA	NA	NA	NA	NA	NA
NRC - 4-wire VG - Facility Termination -1st	U1TV4	NA	\$81.73	NA	NA	NA	NA	NA	NA	NA
NRC - 4-wire VG - Facility Termination - Add'l	U1TV4	NA	\$55.26	NA	NA	NA	NA	NA	NA	NA
NRC - 4-wire VG -Facility Termination - Disconnect Charge -1st	U1TV4	NA	\$31.26	NA	NA	NA	NA	NA	NA	NA
NRC - 4-wire VG - Facility Termination - Disconnect Charge -Add'l	U1TV4	NA	\$12.88	NA	NA	NA	NA	NA	NA	NA
NRC - Manual Svc Order, per LSR	SOMAN	NA	\$21.73	NA	NA	NA	NA	NA	NA	NA
NRC - Manual Svc Order, per LSR disconnect	SOMAN	NA	\$3.87	NA	NA	NA	NA	NA	NA	NA
NRC - Electronic Svc Order, per LSR	SOMEK	NA	\$2.77	NA	NA	NA	NA	NA	NA	NA
NRC - Electronic Svc Order, per LSR disconnect	SOMEK	NA	\$0.43	NA	NA	NA	NA	NA	NA	NA
NRC - 4-wire VG - Incremental Charge--Manual Svc Order - 1st	SOMAN	NA	NA	NA	NA	NA	NA	NA	NA	NA
NRC - 4-wire VG - Incremental Charge--Manual Svc Order - Add'l	SOMAN	NA	NA	NA	NA	NA	NA	NA	NA	NA
NRC - 4-wire VG - Incremental Charge--Manual Svc Order-Disconnect--1st	SOMAN	NA	NA	NA	NA	NA	NA	NA	NA	NA
NRC - 4-wire VG - Incremental Charge--Manual Svc Order-Disconnect--Add'l	SOMAN	NA	NA	NA	NA	NA	NA	NA	NA	NA
Interoffice Transport - Dedicated - DS0 - 56/64 KBPS										
DS0 - per mile per month	1L5XX	\$0.03	\$0.0100	\$0.02	\$0.03	\$0.04	\$0.03	\$0.03	\$0.04	\$0.17
DS0 - Facility Termination per month	U1TD6	\$17.81	\$19.46	\$16.45	\$26.95	\$18.37	\$20.64	\$17.40	\$20.71	\$17.74
NRC - DS0 - Facility Termination - 1st	U1TD6	\$107.11	\$81.74	\$79.61	\$142.31	\$76.20	\$106.72	\$137.48	\$136.44	\$55.39
NRC - DS0 - Facility Termination - Add'l	U1TD6	\$48.27	\$55.26	\$36.08	\$56.21	\$34.54	\$48.83	\$52.58	\$51.37	\$17.37
NRC - DS0 -Facility Termination - Disconnect Charge - 1st	U1TD6	\$37.16	\$31.26	NA	NA	\$28.03	\$38.05	NA	NA	\$27.96
NRC - DS0 - Facility Termination - Disconnect Charge - Add'l	U1TD6	\$5.88	\$12.88	NA	NA	\$5.37	\$7.23	NA	NA	\$3.51
NRC - Manual Svc Order, per LSR	SOMAN	NA	\$21.73	NA	\$19.99	NA	NA	NA	NA	\$19.99
NRC - Manual Svc Order, per LSR disconnect	SOMAN	NA	\$3.87	NA	NA	NA	NA	NA	NA	NA
NRC - Electronic Svc Order, per LSR	SOMEK	\$3.50	\$2.77	\$3.50	\$3.50	\$3.50	\$3.50	\$3.50	\$3.50	\$3.50
NRC - Electronic Svc Order, per LSR disconnect	SOMEK	NA	\$0.43	NA	NA	NA	NA	NA	NA	NA
NRC - DS0 -Incremental Charge--Manual Svc Order - 1st	SOMAN	\$27.37	NA	\$18.94	NA	\$18.14	\$25.52	\$38.07	\$39.63	NA
NRC -DS0 - Incremental Charge--Manual Svc Order - Add'l	SOMAN	\$27.37	NA	\$18.94	NA	\$18.14	\$25.52	\$38.07	\$39.63	NA
NRC - DS0 -Incremental Charge--Manual Svc Order-Disconnect--1st	SOMAN	\$12.97	NA	NA	NA	\$8.06	\$11.34	NA	NA	NA
NRC - DS0 -Incremental Charge--Manual Svc Order-Disconnect--Add'l	SOMAN	\$12.97	NA	NA	NA	\$8.06	\$11.34	NA	NA	NA
Interoffice Transport - Dedicated - DS1										
DS1 - per mile per month	1L5XX	\$0.69	\$0.2035	\$0.31	\$0.45	\$0.78	\$0.66	\$0.5753	\$0.76	\$0.35
DS1 - Facility Termination per month	U1TF1	\$79.69	\$93.31	\$63.39	\$55.05	\$93.40	\$74.40	\$71.29	\$94.98	\$75.83

BELLSOUTH/LEVEL 3 RATES
NETWORK ELEMENTS
AND OTHER SERVICES

DESCRIPTION	USOC	AL	FL	GA	KY	LA	MS	NC	SC	TN
NRC - DS1-Facility Termination - 1st	U1TF1	\$198.15	\$179.99	\$147.07	\$298.18	\$140.49	\$196.28	\$217.17	\$216.27	\$145.98
NRC - DS1 - Facility Termination - Add'l	U1TF1	\$148.18	\$164.95	\$111.75	\$231.23	\$106.69	\$147.31	\$163.75	\$162.70	\$109.85
NRC - DS1 - Facility Termination - Disconnect Charge - 1st	U1TF1	\$25.44	\$30.54	NA	NA	\$20.00	\$26.56	NA	NA	\$19.55
NRC - DS1 - Facility Termination -Disconnect Charge - Add'l	U1TF1	\$20.42	\$26.97	NA	NA	\$16.34	\$21.61	NA	NA	\$14.99
NRC - Manual Svc Order, per LSR	SOMAN	NA	\$21.73	NA	\$19.99	NA	NA	NA	NA	\$19.99
NRC - Manual Svc Order, per LSR disconnect	SOMAN	NA	\$3.87	NA	NA	NA	NA	NA	NA	NA
NRC - Electronic Svc Order, per LSR	SOMEK	\$3.50	\$2.77	\$3.50	\$3.50	\$3.50	\$3.50	\$3.50	\$3.50	\$3.50
NRC - Electronic Svc Order, per LSR disconnect	SOMEK	NA	\$0.43	NA	NA	NA	NA	NA	NA	NA
NRC - DS1 - Incremental Charge--Manual Svc Order - 1st	SOMAN	\$27.37	NA	\$18.94	NA	\$18.14	\$25.52	\$38.07	\$39.63	NA
NRC -DS1 - Incremental Charge--Manual Svc Order - Add'l	SOMAN	\$27.37	NA	\$18.94	NA	\$18.14	\$25.52	\$38.07	\$39.63	NA
NRC - DS1 - Incremental Charge--Manual Svc Order-Disconnect--1st	SOMAN	\$12.97	NA	NA	NA	\$8.06	\$11.31	NA	NA	NA
NRC - DS1 - Incremental Charge--Manual Svc Order-Disconnect--Add'l	SOMAN	\$12.97	NA	NA	NA	\$8.06	\$11.34	NA	NA	NA
Interoffice Transport - Dedicated - DS3										
DS3 - per mile per month	1L5XX	\$4.98	\$4.25	\$2.72	\$12.06	\$6.78	\$15.02	\$12.98	\$8.13	\$6.88
DS3 -Facility Termination per month	U1TF3	\$898.15	\$1,130	\$788.00	\$1,112.02	\$1,025.00	\$744.38	\$720.38	\$967.70	\$840.61
NRC - DS3 - Facility Termination -1st	U1TF3	\$511.77	\$562.06	\$511.10	\$858.75	\$475.31	\$686.74	\$794.94	\$606.72	\$723.44
NRC - DS3 - Facility Termination - Add'l	U1TF3	\$330.92	\$328.16	\$330.77	\$524.95	\$307.62	\$477.76	\$579.55	\$423.45	\$409.58
NRC - DS3 - Facility Termination - Disconnect Charge - 1st	U1TF3	\$121.72	\$112.44	\$122.31	NA	\$113.75	\$125.56	NA	NA	\$154.26
NRC - DS3 - Facility Termination - Disconnect Charge - Add'l	U1TF3	\$118.54	\$109.19	\$119.14	NA	\$110.80	\$118.79	NA	NA	\$130.74
NRC - Manual Svc Order, per LSR	SOMAN	NA	\$21.73	NA	\$19.99	NA	NA	NA	NA	\$19.99
NRC - Manual Svc Order, per LSR disconnect	SOMAN	NA	\$3.87	NA	NA	NA	NA	NA	NA	NA
NRC - Electronic Svc Order, per LSR	SOMEK	\$3.50	\$2.77	\$3.50	\$3.50	\$3.50	\$3.50	\$3.50	\$3.50	\$3.50
NRC - Electronic Svc Order, per LSR disconnect	SOMEK	NA	\$0.43	NA	NA	NA	NA	NA	NA	NA
NRC - DS3 - Incremental Charge--Manual Svc Order - 1st	SOMAN	\$38.48	NA	\$37.55	NA	\$34.92	\$64.97	\$91.26	\$54.26	NA
NRC - DS3 - Incremental Charge--Manual Svc Order - Add'l	SOMAN	\$38.48	NA	\$37.55	NA	\$34.92	\$64.97	\$91.26	\$54.26	NA
NRC - DS3 - Incremental Charge--Manual Svc Order-Disconnect--1st	SOMAN	\$19.03	NA	\$18.03	NA	\$16.77	\$27.08	NA	NA	NA
NRC - DS3 - Incremental Charge--Manual Svc Order-Disconnect--Add'l	SOMAN	\$19.03	NA	\$18.03	NA	\$16.77	\$27.08	NA	NA	NA
Interoffice Transport - Dedicated - STS-1										
STS-1 - per mile per month	1L5XX	\$4.98	\$10.25	\$2.75	\$12.06	\$6.78	\$13.48	\$6.29	\$8.13	\$6.88
STS-1 -Facility Termination per month	U1TS1	\$895.41	\$966.49	\$783.63	\$1,088.67	\$1,000.00	\$692.52	\$800.94	\$967.58	\$838.65
NRC - STS-1 - Facility Termination -1st	U1TS1	\$511.77	\$868.23	\$511.10	\$858.75	\$475.31	\$858.15	\$624.86	\$606.72	\$858.26
NRC - STS-1 - Facility Termination - Add'l	U1TS1	\$330.92	\$530.74	\$449.91	\$524.94	\$307.62	\$524.58	\$436.36	\$423.45	\$525.25
NRC - STS-1 - Facility Termination - Disconnect Charge - 1st	U1TS1	\$121.72	\$112.44	\$122.31	NA	\$113.75	\$125.56	NA	NA	\$154.26
NRC - STS-1 - Facility Termination - Disconnect Charge - Add'l	U1TS1	\$118.54	\$109.19	\$119.14	NA	\$110.80	\$118.79	NA	NA	\$130.74
NRC - Manual Svc Order, per LSR	SOMAN	NA	\$21.73	NA	\$19.99	NA	NA	NA	NA	\$19.99
NRC - Manual Svc Order, per LSR disconnect	SOMAN	NA	\$3.87	NA	NA	NA	NA	NA	NA	NA
NRC - Electronic Svc Order, per LSR	SOMEK	\$3.50	\$2.77	\$3.50	\$3.50	\$3.50	\$3.50	\$3.50	\$3.50	\$3.50
NRC - Electronic Svc Order, per LSR disconnect	SOMEK	NA	\$0.43	NA	NA	NA	NA	NA	NA	NA
NRC - STS-1 - Incremental Charge--Manual Svc Order - 1st	SOMAN	\$38.48	NA	\$37.55	NA	\$34.92	\$94.50	\$55.00	\$54.26	NA
NRC - STS-1 - Incremental Charge--Manual Svc Order - Add'l	SOMAN	\$38.48	NA	\$37.55	NA	\$34.92	\$94.50	\$55.00	\$54.26	NA
NRC - DS3 - Incremental Charge--Manual Svc Order-Disconnect--1st	SOMAN	\$19.03	NA	\$18.03	NA	\$16.77	\$27.08	NA	NA	NA
NRC - DS3 - Incremental Charge--Manual Svc Order-Disconnect--Add'l	SOMAN	\$19.03	NA	\$18.03	NA	\$16.77	\$27.08	NA	NA	NA
Interoffice Transport - Dedicated - OC3										
OC3 -per mile per month	TBD	\$4.98	\$8.38	\$4.37	\$28.56	\$23.89	\$18.35	\$24.69	\$9.75	\$13.45
OC3 -Facility Termination per month	TBD	\$898.15	\$3,043	\$2,187.00	\$1,493	\$2,990.00	\$1,892.00	\$611.36	\$2,802	\$2,124.00
NRC - OC-3 - Facility Termination - 1st	TBD	\$511.77	\$876.46	\$819.29	\$1,543	\$927.35	\$1,283.00	\$1,411	\$915.64	\$950.10
NRC - OC-3 - Facility Termination - Add'l	TBD	\$330.92	\$314.49	\$317.38	\$661.23	\$304.90	\$404.94	\$542.73	\$410.02	\$311.39
NRC - OC-3 - Facility Termination - Disconnect Charge - 1st	TBD	\$121.72	\$112.44	\$122.31	NA	\$102.16	\$134.07	\$131.65	NA	\$103.36
NRC - OC-3 - Facility Termination - Disconnect Charge - Add'l	TBD	\$118.54	\$109.19	\$119.14	NA	\$99.46	\$130.59	\$128.19	NA	\$100.59
NRC - Manual Svc Order, per LSR	SOMAN	NA	\$21.73	NA	\$19.99	NA	NA	NA	NA	\$19.99
NRC - Manual Svc Order, per LSR disconnect	SOMAN	NA	\$3.87	NA	NA	NA	NA	NA	NA	NA
NRC - Electronic Svc Order, per LSR	SOMEK	\$3.50	\$2.77	\$3.50	\$3.50	\$3.50	\$3.50	\$3.50	\$3.50	\$3.50
NRC - Electronic Svc Order, per LSR disconnect	SOMEK	NA	\$0.43	NA	NA	NA	NA	NA	NA	NA

BELLSOUTH/LEVEL 3 RATES
NETWORK ELEMENTS
AND OTHER SERVICES

DESCRIPTION	USOC	AL	FL	GA	KY	LA	MS	NC	SC	TN
NRC - OC3 - Incremental Cost - Manual Svc Order vs. Electronic-1st	SOMAN	\$38.48	NA	\$37.55	NA	\$50.25	\$68.62	\$69.34	\$54.26	NA
NRC - OC3 - Incremental Cost - Manual Svc Order vs. Electronic-Add'l	SOMAN	\$38.48	NA	\$37.55	NA	\$50.25	\$68.62	\$69.34	\$54.26	NA
NRC - OC3 - Incremental Cost - Manual Svc Order vs. Electronic-Disconnect	SOMAN	\$19.03	NA	\$18.03	NA	\$20.94	\$28.59	\$29.76	NA	NA
NRC - OC3 - Incremental Cost - Manual Svc Order vs. Electronic-Disconnect-Add'l	SOMAN	\$19.03	NA	\$18.03	NA	\$20.94	\$28.59	\$29.76	NA	NA
Interoffice Transport - Dedicated - OC12										
OC12 -per mile per month	TBD	\$19.26	\$26.91	\$15.05	\$84.88	\$74.44	\$60.42	\$30.38	\$32.52	\$49.80
OC12 -Facility Termination	TBD	\$9,763	\$11,685	\$8,202.00	\$12,344	\$11,517.00	\$7,182.00	\$2,122	\$11,132	\$8,015.00
NRC - OC12- Facility Termination - 1st	TBD	\$1,036	\$1,095	\$1,034.00	\$1,399	\$1,147.00	\$1,598.00	\$1,722	\$1,131	\$1,176.00
NRC - OC12- Facility Termination - Add'l	TBD	\$317.48	\$314.49	\$317.38	\$516.89	\$304.90	\$404.94	\$542.73	\$410.02	\$311.39
NRC - OC12 - Facility Termination - Disconnect Chg - 1st	TBD	\$121.72	\$112.44	\$122.31	NA	\$102.16	\$134.07	\$131.65	NA	\$103.36
NRC - OC12 - Facility Termination - Disconnect Chg - Add'l	TBD	\$118.54	\$109.19	\$119.14	NA	\$99.46	\$130.59	\$128.19	NA	\$100.59
NRC - Manual Svc Order, per LSR	SOMAN	NA	\$21.73	NA	\$19.99	NA	NA	NA	NA	\$19.99
NRC - Manual Svc Order, per LSR disconnect	SOMAN	NA	\$3.87	NA	NA	NA	NA	NA	NA	NA
NRC - Electronic Svc Order, per LSR	SOMECE	\$3.50	\$2.77	\$3.50	\$3.50	\$3.50	\$3.50	\$3.50	\$3.50	\$3.50
NRC - Electronic Svc Order, per LSR disconnect	SOMECE	NA	\$0.43	NA	NA	NA	NA	NA	NA	NA
NRC - OC12 - Incremental Cost - Manual Svc Order vs. Electronic-1st	SOMAN	\$38.48	NA	\$37.55	NA	\$50.25	\$68.62	\$69.34	\$54.26	NA
NRC - OC12 - Incremental Cost - Manual Svc Order vs. Electronic-Add'l	SOMAN	\$38.48	NA	\$37.55	NA	\$50.25	\$68.62	\$69.34	\$54.26	NA
NRC - OC12 - Incremental Cost - Manual Svc Order vs. Elect-Disconnect-1st	SOMAN	\$19.03	NA	\$18.03	NA	\$20.94	\$28.59	\$29.76	NA	NA
NRC - OC12 - Incremental Cost - Manual Svc Order vs. Elect-Disconnect-Add'l	SOMAN	\$19.03	NA	\$18.03	NA	\$20.94	\$28.59	\$29.76	NA	NA
Interoffice Transport - Dedicated - OC48										
OC48 -per mile per month	TBD	\$30.65	\$34.66	\$25.70	\$138.02	\$128.59	\$102.43	\$120.02	\$45.92	\$106.55
OC48 -Facility Termination per month	TBD	\$11,691	\$12,554	\$11,134.00	\$16,017.00	\$14,950.00	\$11,480.00	\$1,677	\$967.58	\$11,632.00
OC48 -per Interface OC12 on OC48 per month	TBD	\$1,424	\$1,208	\$1,137.00	\$1,497.00	\$1,451.00	\$1,351.00	\$582.66	\$1,561	\$1,170.00
NRC - OC48 - Facility Termination - 1st	TBD	\$1,036	\$1,095	\$1,034.00	\$1,713.00	\$1,147.00	\$1,598.00	\$1,722	\$1,131	\$1,176.00
NRC - OC48 - Facility Termination - Add'l	TBD	\$317.48	\$314.49	\$317.38	\$516.89	\$304.90	\$404.94	\$542.73	\$410.02	\$311.39
NRC - OC48 - Interface OC12 on OC48 - 1st	TBD	\$540.10	\$547.98	\$539.36	\$844.21	\$532.13	\$729.04	\$720.81	\$635.04	\$544.55
NRC - OC48 - Interface OC12 on OC48 - Add'l	TBD	\$317.48	\$314.49	\$317.38	\$516.89	\$304.90	\$404.94	\$400.38	\$410.02	\$311.39
NRC - OC48 - Facility Termination - Disconnect Chg - 1st	TBD	\$121.72	\$112.44	\$122.31	NA	\$102.16	\$134.07	\$131.65	NA	\$103.36
NRC - OC48 - Facility Termination - Disconnect Chg - Add'l	TBD	\$118.54	\$109.19	\$119.14	NA	\$99.46	\$130.59	\$128.19	NA	\$100.59
NRC - OC48 - Interface OC12 on OC48 - Disconnect - 1st	TBD	\$121.72	\$112.44	\$122.31	NA	\$102.16	\$134.07	\$131.65	NA	\$103.36
NRC - OC48 - Interface OC12 on OC48 - Disconnect - Add'l	TBD	\$118.54	\$109.19	\$119.14	NA	\$99.46	\$130.59	\$128.19	NA	\$100.59
NRC - Manual Svc Order, per LSR	SOMAN	NA	\$21.73	NA	\$19.99	NA	NA	NA	NA	\$19.99
NRC - Manual Svc Order, per LSR disconnect	SOMAN	NA	\$3.87	NA	NA	NA	NA	NA	NA	NA
NRC - Electronic Svc Order, per LSR	SOMECE	\$3.50	\$2.77	\$3.50	\$3.50	\$3.50	\$3.50	\$3.50	\$3.50	\$3.50
NRC - Electronic Svc Order, per LSR disconnect	SOMECE	NA	\$0.43	NA	NA	NA	NA	NA	NA	NA
NRC - OC48 - Incremental Cost - Manual Svc. Order vs. Electronic-1st	SOMAN	\$38.48	NA	\$37.55	NA	\$50.25	\$68.62	\$69.34	\$54.26	NA
NRC - OC48 - Incremental Cost - Manual Svc. Order vs. Electronic-Add'l	SOMAN	\$38.48	NA	\$37.55	NA	\$50.25	\$68.62	\$69.34	\$54.26	NA
NRC - OC48 - Interface- Incremental Cost - Manual Svc. Order vs. Electronic-Add'l	SOMAN	\$38.48	NA	\$37.55	NA	\$50.25	\$68.62	\$69.34	\$54.26	NA
NRC - OC48 - Interface- Incremental Cost - Manual Svc. Order vs. Electronic-Disconnect	SOMAN	\$38.48	NA	\$37.55	NA	\$50.25	\$68.62	\$69.34	\$54.26	NA
NRC - OC48 - Interface OC12 on OC48 - Disconnect - 1st	SOMAN	\$121.72	NA	\$18.03	NA	NA	NA	\$131.65	NA	NA
NRC - OC48 - Interface OC12 on OC48 - Disconnect - Add'l	SOMAN	\$118.54	NA	\$18.03	NA	\$99.46	\$130.59	\$128.19	NA	NA
NRC - OC48 - Incremental Cost - Manual Svc. Order vs. Elect-Disconnect-1st	SOMAN	\$19.03	NA	\$18.03	NA	\$20.94	\$28.59	\$29.76	NA	NA
NRC - OC48 - Incremental Cost - Manual Svc. Order vs. Elect-Disconnect-Add'l	SOMAN	\$19.03	NA	\$18.03	NA	\$20.94	\$28.59	\$29.76	NA	NA
NRC - OC48-Interface-Incremental Cost-Manual Svc. Order vs. Elec-Disconnect-1st	SOMAN	\$19.03	NA	\$18.03	NA	\$20.94	\$28.59	\$29.76	NA	NA
NRC - OC48-Interface-Incremental Cost-Manual Svc. Order vs. Elec-Disconnect-Add'l	SOMAN	\$19.03	NA	\$18.03	NA	\$20.94	\$28.59	\$29.76	NA	NA
UNBUNDLED DEDICATED TRANSPORT - Local Channel										
Local Channel - Dedicated - 2-Wire VG										
Monthly Recurring per month	ULDV2	\$14.61	\$26.31	\$13.91	\$22.26	\$14.94	\$17.83	\$14.83	\$16.83	\$19.02
Zone 1	TBD	NA	NA	\$11.91	NA	NA	NA	NA	NA	\$16.42
Zone 2	TBD	NA	NA	\$13.83	NA	NA	NA	NA	NA	\$20.66
Zone 3	TBD	NA	NA	\$21.98	NA	NA	NA	NA	NA	\$29.61
Zone 4	TBD	NA	NA	NA	NA	NA	NA	NA	NA	NA
NRC - 2-wire VG - 1st	ULDV2	\$494.65	\$389.37	\$382.95	\$585.15	\$347.49	\$487.62	\$553.80	\$554.00	\$199.33

BELLSOUTH/LEVEL 3 RATES
NETWORK ELEMENTS
AND OTHER SERVICES

DESCRIPTION	USOC	AL	FL	GA	KY	LA	MS	NC	SC	TN
NRC - 2-wire VG -Add'l	ULDV2	\$88.44	\$66.88	\$62.40	\$98.53	\$59.75	\$84.35	\$89.69	\$88.58	\$24.16
NRC - 2-Wire VG - Disconnect Chg - 1st	ULDV2	\$77.81	\$68.45	NA	\$11.99	\$53.68	\$77.69	NA	NA	\$54.81
NRC - 2-Wire VG - Disconnect Chg - Add'l	ULDV2	\$7.63	\$5.97	NA	NA	\$6.60	\$8.95	NA	NA	\$4.80
NRC - Manual Svc Order, per LSR	SOMAN	NA	\$21.73	NA	\$19.99	NA	NA	NA	NA	\$19.99
NRC - Manual Svc Order, per LSR disconnect	SOMAN	NA	\$3.87	NA	NA	NA	NA	NA	NA	NA
NRC - Electronic Svc Order, per LSR	SOMEK	\$3.50	\$2.77	\$3.50	\$3.50	\$3.50	\$3.50	\$3.50	\$3.50	\$3.50
NRC - Electronic Svc Order, per LSR disconnect	SOMEK	NA	\$0.43	NA	NA	NA	NA	NA	NA	NA
NRC - 2-Wire VG - Incremental Charge--Manual Svc Order - 1st	SOMAN	\$27.37	NA	\$18.94	NA	\$18.14	\$25.52	\$42.17	\$43.75	NA
NRC - 2-Wire VG - Incremental Charge--Manual Svc Order - Add'l	SOMAN	\$18.37	NA	\$8.42	NA	\$8.06	\$11.34	\$12.76	\$13.55	NA
NRC - 2-Wire VG - Incremental Charge--Manual Svc Order-Disconnect	SOMAN	\$17.75	NA	NA	NA	\$11.40	\$16.05	NA	NA	NA
Local Channel - Dedicated - 4-Wire VG										
Monthly Recurring per month	ULDD6	\$15.77	\$27.48	\$14.99	\$23.38	\$16.21	\$19.03	\$15.87	\$18.05	\$20.14
Zone 1	TBD	NA	NA	\$12.90	NA	NA	NA	NA	NA	\$17.38
Zone 2	TBD	NA	NA	\$14.90	NA	NA	NA	NA	NA	\$21.88
Zone 3	TBD	NA	NA	\$23.68	NA	NA	NA	NA	NA	\$31.36
Zone 4	TBD	NA	NA	NA	NA	NA	NA	NA	NA	NA
NRC - 4-Wire VG - 1st	ULDD6	\$502.43	\$390.25	\$368.44	\$585.15	\$352.75	\$495.25	\$562.23	\$562.46	\$201.53
NRC - 4-Wire VG - Add'l	ULDD6	\$86.68	\$67.75	\$64.05	\$98.53	\$61.33	\$86.56	\$92.67	\$91.57	\$24.83
NRC - 4-Wire VG - Disconnect Chg - 1st	ULDD6	\$78.71	\$69.32	NA	NA	\$54.36	\$78.58	NA	NA	\$55.52
NRC - 4-Wire VG - Disconnect Chg - Add'l	ULDD6	\$8.53	\$6.85	NA	NA	\$7.28	\$9.84	NA	NA	\$5.51
NRC - Manual Svc Order, per LSR	SOMAN	NA	\$21.73	NA	\$19.99	NA	NA	NA	NA	\$19.99
NRC - Manual Svc Order, per LSR disconnect	SOMAN	NA	\$3.87	NA	NA	NA	NA	NA	NA	NA
NRC - Electronic Svc Order, per LSR	SOMEK	NA	\$2.77	\$3.50	\$3.50	\$3.50	\$3.50	\$3.50	\$3.50	\$3.50
NRC - Electronic Svc Order, per LSR disconnect	SOMEK	\$3.50	\$0.43	NA	NA	NA	NA	NA	NA	NA
NRC - 4-Wire VG - Incremental Charge--Manual Svc Order - 1st	SOMAN	\$27.37	NA	\$18.94	NA	\$18.14	\$25.52	\$42.17	\$43.64	NA
NRC - 4-Wire VG - Incremental Charge--Manual Svc Order - Add'l	SOMAN	\$18.73	NA	\$8.42	NA	\$8.06	\$11.34	\$12.76	\$13.55	NA
NRC - 4-Wire VG - Incremental Charge--Manual Svc Order-Disconnect	SOMAN	\$17.75	NA	NA	NA	\$11.40	\$16.05	NA	NA	NA
Local Channel - Dedicated - DS1										
DS1 Monthly Recurring per month	ULDF1	\$35.52	\$42.98	\$38.36	\$43.80	\$43.80	\$38.91	\$35.68	\$37.20	\$40.27
DS1 per mile per month	1L5NC	\$0.00	\$0.00	\$0.00	\$0.00	\$0.00	\$0.00	\$0.00	\$0.00	\$0.00
Zone 1	TBD	NA	NA	\$33.02	NA	NA	NA	NA	NA	\$34.76
Zone 2	TBD	NA	NA	\$38.13	NA	NA	NA	NA	NA	\$43.75
Zone 3	TBD	NA	NA	\$60.60	NA	NA	NA	NA	NA	\$62.70
Zone 4	TBD	NA	NA	NA	NA	NA	NA	NA	NA	NA
NRC - DS1 - 1st	ULDF1	\$503.57	\$357.86	\$356.15	\$538.95	\$348.56	\$494.83	\$534.48	\$534.81	\$277.35
NRC - DS1 - Add'l	ULDF1	\$442.84	\$309.95	\$312.89	\$464.94	\$300.30	\$435.28	\$462.69	\$462.81	\$233.26
NRC - DS1 - Disconnect Chg - 1st	ULDF1	\$46.28	\$41.46	NA	NA	\$24.15	\$46.85	NA	NA	\$33.18
NRC - DS1 - Disconnect Chg - Add'l	ULDF1	\$32.18	\$28.51	NA	NA	\$21.31	\$33.02	NA	NA	\$22.30
NRC - Manual Svc Order, per LSR	SOMAN	NA	\$21.73	NA	\$19.99	NA	NA	NA	NA	\$19.99
NRC - Manual Svc Order, per LSR disconnect	SOMAN	NA	\$3.87	NA	NA	NA	NA	NA	NA	NA
NRC - Electronic Svc Order, per LSR	SOMEK	\$3.50	\$2.77	\$3.50	\$3.50	\$3.50	\$3.50	\$3.50	\$3.50	\$3.50
NRC - Electronic Svc Order, per LSR disconnect	SOMEK	NA	\$0.43	NA	NA	NA	NA	NA	NA	NA
NRC - DS1 - Incremental Charge--Manual Svc Order - 1st	SOMAN	\$61.95	NA	\$44.22	NA	\$42.34	\$59.58	\$86.15	\$87.99	NA
NRC - DS1 - Incremental Charge--Manual Svc Order - Add'l	SOMAN	\$0.00	NA	NA	NA	NA	NA	\$1.77	\$3.11	NA
NRC - DS1 - Incremental Charge--Manual Svc Order-Disconnect	SOMAN	\$29.27	NA	NA	NA	\$19.48	\$27.51	NA	NA	NA
Local Channel - Dedicated - DS3										
DS3 - per mile per month	1L5NC	\$8.44	\$9.32	\$6.92	\$34.00	\$8.77	NA	NA	\$12.08	\$23.76
DS3 - Facility Termination per month	ULDF3	\$535.92	\$560.39	\$515.91	\$635.09	\$573.23	\$533.33	\$498.87	\$493.31	\$607.28
NRC - DS3 - Facility Termination - 1st	ULDF3	\$640.54	\$910.45	\$639.50	\$1,091.00	\$594.71	\$526.67	\$562.25	\$735.42	\$726.16
NRC - DS3 - Facility Termination - Add'l	ULDF3	\$426.28	\$532.19	\$426.40	\$661.23	\$396.54	\$493.71	\$527.88	\$519.31	\$411.64
NRC - DS3 - Facility Termination - Disconnect - 1st	ULDF3	\$121.72	\$112.44	\$122.31	NA	\$113.75	\$42.41	NA	NA	\$103.36
NRC - DS3 - Facility Termination - Disconnect - Add'l	ULDF3	\$118.54	\$156.12	\$119.14	NA	\$110.80	\$40.87	NA	NA	\$100.59
NRC - Manual Svc Order, per LSR	SOMAN	NA	\$21.73	NA	\$19.99	NA	NA	NA	NA	\$19.99

BELLSOUTH/LEVEL 3 RATES
NETWORK ELEMENTS
AND OTHER SERVICES

DESCRIPTION	USOC	AL	FL	GA	KY	LA	MS	NC	SC	TN
NRC - Manual Svc Order, per LSR disconnect	SOMAN	NA	\$3.87	NA	NA	NA	NA	NA	NA	NA
NRC - Electronic Svc Order, per LSR	SOMEK	\$3.50	\$2.77	\$3.50	\$3.50	\$3.50	\$3.50	\$3.50	\$3.50	\$3.50
NRC - Electronic Svc Order, per LSR disconnect	SOMEK	NA	\$0.43	NA	NA	NA	NA	NA	NA	NA
NRC - DS3 -Incremental Charge--Manual Svc Order - 1st	SOMAN	\$38.48	NA	\$37.55	NA	\$34.92	\$31.49	\$56.25	\$54.26	NA
NRC - DS3 - Incremental Charge--Manual Svc Order - Add'l	SOMAN	\$38.48	NA	\$37.55	NA	\$34.92	\$31.49	\$56.25	\$54.26	NA
NRC - DS3 - Incremental Charge--Manual Svc Order-Disconnect -1st	SOMAN	\$19.03	NA	\$18.03	NA	\$16.77	\$25.35	NA	NA	NA
NRC - DS3 - Incremental Charge--Manual Svc Order-Disconnect-Add'l	SOMAN	\$19.03	NA	\$18.03	NA	\$16.77	\$25.35	NA	NA	NA
Local Channel - Dedicated - STS-1										
STS-1 - per mile per month	1L5NC	\$8.44	\$9.32	\$6.92	\$30.04	\$8.77	\$38.98	NA	\$12.08	\$25.11
STS-1 - Facility Termination per month	ULDFS	\$525.40	\$569.67	\$517.56	\$610.64	\$558.00	\$531.39	\$512.00	\$481.14	\$615.65
NRC - STS-1 - Facility Termination - 1st	ULDFS	\$640.54	\$910.45	\$639.50	\$1,085.09	\$594.71	\$1,084.33	\$757.25	\$735.42	\$1,085.73
NRC - STS-1 - Facility Termination - Add'l	ULDFS	\$426.82	\$532.19	\$426.40	\$682.61	\$396.54	\$682.13	\$534.95	\$519.31	\$683.01
NRC - STS-1 - Facility Termination - Disconnect - 1st	ULDFS	\$121.72	\$223.20	\$122.31	NA	\$113.75	\$42.41	NA	NA	\$103.36
NRC - STS-1 - Facility Termination - Disconnect - Add'l	ULDFS	\$118.54	\$156.12	\$119.14	NA	\$110.80	\$40.87	NA	NA	\$100.59
NRC - Manual Svc Order, per LSR	SOMAN	NA	\$21.73	NA	\$19.99	NA	NA	NA	NA	\$19.99
NRC - Manual Svc Order, per LSR disconnect	SOMAN	NA	\$3.87	NA	NA	NA	NA	NA	NA	NA
NRC - Electronic Svc Order, per LSR	SOMEK	\$3.50	\$2.77	\$3.50	\$3.50	\$3.50	\$3.50	\$3.50	\$3.50	\$3.50
NRC - Electronic Svc Order, per LSR disconnect	SOMEK	NA	\$0.43	NA	NA	NA	NA	NA	NA	NA
NRC - STS-1 -Incremental Charge--Manual Svc Order - 1st	SOMAN	\$38.48	NA	\$37.55	NA	\$34.92	\$96.10	\$55.00	\$54.26	NA
NRC - STS-1 - Incremental Charge--Manual Svc Order - Add'l	SOMAN	\$38.48	NA	\$37.55	NA	\$34.92	\$96.10	\$55.00	\$54.26	NA
NRC - STS-1 - Incremental Charge--Manual Svc Order-Disconnect -1st	SOMAN	\$19.03	NA	\$18.03	NA	\$16.77	\$25.35	NA	NA	NA
NRC - STS-1 - Incremental Charge--Manual Svc Order-Disconnect-Add'l	SOMAN	\$19.03	NA	\$18.03	NA	\$16.77	\$25.35	NA	NA	NA
Local Channel - Dedicated - OC3										
OC3 per mile per month	TBD	\$7.09	\$9.08	\$5.82	\$28.56	\$25.48	\$35.55	\$24.69	\$10.15	\$19.95
OC3 Facility Termination per month	TBD	\$1,123	\$651.40	\$914.22	\$1,493.00	\$1,179.00	\$873.23	\$611.36	\$493.31	\$1,263.00
NRC - OC3 - Facility Termination - 1st	TBD	\$949.63	\$974.02	\$947.69	\$1,543.00	\$1,025.00	\$1,427.00	\$1,411	\$735.42	\$1,050.00
NRC - OC3 - Facility Termination - Add'l	TBD	\$413.38	\$412.05	\$413.00	\$661.23	\$402.63	\$549.17	\$542.73	\$519.31	\$411.64
NRC - OC3 - Facility Termination - Disconnect Chg - 1st	TBD	\$121.72	\$112.44	\$122.31	NA	\$102.16	\$134.07	\$131.65	NA	\$103.36
NRC - OC3 - Facility Termination - Disconnect Chg - Add'l	TBD	\$118.54	\$109.19	\$119.14	NA	\$99.46	\$130.59	\$128.19	NA	\$100.59
NRC - Manual Svc Order, per LSR	SOMAN	NA	\$21.73	NA	\$19.99	NA	NA	NA	NA	\$19.99
NRC - Manual Svc Order, per LSR disconnect	SOMAN	NA	\$3.87	NA	NA	NA	NA	NA	NA	NA
NRC - Electronic Svc Order, per LSR	SOMEK	\$3.50	\$2.77	\$3.50	\$3.50	\$3.50	\$3.50	\$3.50	\$3.50	\$3.50
NRC - Electronic Svc Order, per LSR disconnect	SOMEK	NA	\$0.43	NA	NA	NA	NA	NA	NA	NA
NRC - OC3 - Incremental Charge--Manual Svc Order - 1st	SOMAN	\$38.48	NA	\$37.55	NA	\$50.25	\$68.62	\$69.34	\$54.26	NA
NRC - OC3 - Incremental Charge--Manual Svc Order - Add'l	SOMAN	\$38.48	NA	\$37.55	NA	\$50.25	\$68.62	\$69.34	\$54.26	NA
NRC - OC3 - Incremental Charge--Manual Svc Order-Disconnect-1st	SOMAN	\$19.03	NA	\$18.03	NA	\$20.94	\$28.59	\$29.76	NA	NA
NRC - OC3 - Incremental Charge--Manual Svc Order-Disconnect-Add'l	SOMAN	\$19.03	NA	\$18.03	NA	\$20.94	\$28.59	\$29.76	NA	NA
Local Channel - Dedicated - OC12										
OC12 per mile per month	TBD	\$10.13	\$11.18	\$8.31	\$40.80	\$36.40	\$50.79	\$30.38	\$14.50	\$28.51
OC12 Facility Termination per month	TBD	\$5,630	\$2,068	\$3,185.00	\$4,492.00	\$3,895.00	\$3,414.00	\$2,122	\$4,414	\$7,158.00
NRC - OC12 - Facility Termination - 1st	TBD	\$1,165	\$1,193	\$1,162.00	\$1,858.00	\$1,245.00	\$1,742.00	\$1,722	\$1,259	\$1,276.00
NRC - OC12 - Facility Termination - Add'l	TBD	\$413.38	\$412.05	\$413.00	\$661.23	\$402.63	\$549.17	\$542.73	\$505.88	\$411.64
NRC - OC12 - Facility Termination -Disconnect Chg - 1st	TBD	\$121.72	\$112.44	\$122.31	NA	\$102.16	\$134.07	\$131.65	NA	\$103.36
NRC - OC12 - Facility Termination - Disconnect Chg - Add'l	TBD	\$118.54	\$109.19	\$119.14	NA	\$99.46	\$130.59	\$128.19	NA	\$100.59
NRC - Manual Svc Order, per LSR	SOMAN	NA	\$21.73	NA	\$19.99	NA	NA	NA	NA	\$19.99
NRC - Manual Svc Order, per LSR disconnect	SOMAN	NA	\$3.87	NA	NA	NA	NA	NA	NA	NA
NRC - Electronic Svc Order, per LSR	SOMEK	\$3.50	\$2.77	\$3.50	\$3.50	\$3.50	\$3.50	\$3.50	\$3.50	\$3.50
NRC - Electronic Svc Order, per LSR disconnect	SOMEK	NA	\$0.43	NA	NA	NA	NA	NA	NA	NA
NRC - OC12 - Incremental Charge--Manual Svc Order - 1st	SOMAN	\$38.48	NA	\$37.55	NA	\$50.25	\$68.62	\$69.34	\$54.26	NA
NRC - OC12 - Incremental Charge--Manual Svc Order - Add'l	SOMAN	\$38.48	NA	\$37.55	NA	\$50.25	\$68.62	\$69.34	\$54.26	NA
NRC - OC12 - Incremental Charge--Manual Svc Order-Disconnect-1st	SOMAN	\$19.03	NA	\$18.03	NA	\$20.94	\$28.59	\$29.76	NA	NA
NRC - OC12 - Incremental Charge--Manual Svc Order-Disconnect-Add'l	SOMAN	\$19.03	NA	\$18.03	NA	\$20.94	\$28.59	\$29.76	NA	NA

BELLSOUTH/LEVEL 3 RATES
NETWORK ELEMENTS
AND OTHER SERVICES

DESCRIPTION	USOC	AL	FL	GA	KY	LA	MS	NC	SC	TN
Local Channel - Dedicated - OC48										
OC48 per mile per month	TBD	\$33.22	\$36.67	\$27.25	\$133.84	\$119.40	\$166.59	\$120.02	\$47.57	\$93.50
OC48 Facility Termination per month	TBD	\$1,947	\$1,699	\$1,671.00	\$2,156.00	\$2,311.00	\$1,768.00	\$1,677	\$1,842	\$1,853.00
OC48 - Interface OC12 on OC48 per month	TBD	\$699.62	\$592.09	\$558.07	\$728.81	\$706.85	\$668.36	\$582.66	\$773.40	\$572.61
NRC - OC48 - Facility Termination - 1st	TBD	\$1,165	\$1,193	\$1,162.00	\$1,858.00	\$1,245.00	\$1,742.00	\$1,722	\$1,259	\$1,276.00
NRC - OC48 - Facility Termination -Add'l	TBD	\$413.38	\$412.05	\$413.00	\$661.23	\$402.63	\$549.17	\$542.73	\$505.88	\$411.64
NRC - OC48 - Interface OC12 on OC48 - 1st	TBD	\$540.10	\$547.98	\$539.36	\$844.21	\$532.13	\$729.04	\$720.81	\$635.04	\$544.55
NRC -OC48 - Interface OC12 on OC48 -Add'l	TBD	\$317.48	\$314.49	\$317.38	\$516.89	\$304.90	\$404.94	\$400.38	\$410.02	\$311.39
NRC - OC48 - Facility Termination - Disconnect Chg - 1st	TBD	\$121.72	\$112.44	\$122.31	NA	\$102.16	\$134.07	\$131.65	NA	\$103.36
NRC - OC48 - Facility Termination - Disconnect Chg - Add'l	TBD	\$118.54	\$109.19	\$119.14	NA	\$99.46	\$130.59	\$128.19	NA	\$100.59
NRC - OC48 - Interface OC12 on OC48 - Disconnect Chg - 1st	TBD	\$121.72	\$112.44	\$122.31	NA	\$102.16	\$134.07	\$131.65	NA	\$103.36
NRC - OC48 - Interface OC12 on OC48 - Disconnect Chg - Add'l	TBD	\$118.54	\$109.19	\$119.14	NA	\$99.46	\$130.59	\$128.19	NA	\$100.59
NRC - Manual Svc Order, per LSR	SOMAN	NA	\$21.73	NA	\$19.99	NA	NA	NA	NA	\$19.99
NRC - Manual Svc Order, per LSR disconnect	SOMAN	NA	\$3.87	NA	NA	NA	NA	NA	NA	NA
NRC - Electronic Svc Order, per LSR	SOMECE	\$3.50	\$2.77	\$3.50	\$3.50	\$3.50	\$3.50	\$3.50	\$3.50	\$3.50
NRC - Electronic Svc Order, per LSR disconnect	SOMECE	NA	\$0.43	NA	NA	NA	NA	NA	NA	NA
NRC - OC48 - Incremental Charge--Manual Svc Order - 1st	SOMAN	\$38.48	NA	\$37.55	NA	\$50.25	\$68.62	\$69.34	\$54.26	NA
NRC - OC48 - Incremental Charge--Manual Svc Order - Add'l	SOMAN	\$38.48	NA	\$37.55	NA	\$50.25	\$68.62	\$69.34	\$54.26	NA
NRC - OC48 -Interface-Incremental Cost-Manual Svc. Order vs. Electronic-I	SOMAN	\$38.48	NA	\$37.55	NA	\$50.25	\$68.62	\$69.34	\$54.26	NA
NRC - OC48 -Interface-Incremental Cost-Manual Svc. Order vs. Electronic-A	SOMAN	\$38.48	NA	\$37.55	NA	\$50.25	\$68.62	\$69.34	\$54.26	NA
NRC - OC48 - Incremental Charge--Manual Svc Order-Disconnect-1st	SOMAN	\$19.03	NA	\$18.03	NA	\$20.94	\$28.59	\$29.76	NA	NA
NRC - OC48 - Incremental Charge--Manual Svc Order-Disconnect-Add'l	SOMAN	\$19.03	NA	\$18.03	NA	\$20.94	\$28.59	\$29.76	NA	NA
NRC - OC48 -Interface-Incremental Cost-Manual Svc. Order vs. Electronic-D	SOMAN	\$19.03	NA	\$18.03	NA	\$20.94	\$28.59	\$29.76	NA	NA
NRC - OC48 -Interface-Incremental Cost-Manual Svc. Order vs. Electronic-D	SOMAN	\$19.03	NA	\$18.03	NA	\$20.94	\$28.59	\$29.76	NA	NA
DS3 Channelization (DS3 to DS1)										
per Channelized System (28 DS1) per month	MQ3	\$225.36	\$222.61	\$182.04	\$236.32	\$244.37	\$229.30	\$236.35	\$200.01	\$225.59
NRC - 1st	MQ3	\$265.87	\$359.20	\$265.91	\$425.41	\$247.30	\$356.80	\$331.54	\$321.54	\$265.08
NRC - Add'l	MQ3	\$188.51	\$299.24	\$188.78	\$303.33	\$175.57	\$247.40	\$241.81	\$234.30	\$185.94
NRC -1st - Disconnect	MQ3	\$11.67	\$189.04	\$72.50	NA	\$67.42	\$79.94	NA	NA	\$61.09
NRC -Add'l - Disconnect	MQ3	\$0.95	\$186.37	\$59.96	NA	\$49.13	\$65.20	NA	NA	\$50.31
per Interface per month (COCI)	UC1D1	\$17.22	\$14.51	\$11.02	\$8.52	\$15.49	\$5.58	\$16.29	\$11.99	\$3.91
NRC - 1st	UC1D1	\$12.05	\$13.26	\$12.02	\$15.86	\$11.18	\$15.85	\$12.39	\$12.05	\$12.61
NRC - Add'l	UC1D1	\$8.69	\$9.50	\$8.66	\$11.36	\$8.06	\$11.35	\$8.93	\$8.68	\$9.03
NRC - Manual Svc Order, per LSR	SOMAN	NA	\$21.73	NA	\$19.99	NA	NA	NA	NA	\$19.99
NRC - Manual Svc Order, per LSR disconnect	SOMAN	NA	\$3.87	NA	NA	NA	NA	NA	NA	NA
NRC - Electronic Svc Order, per LSR	SOMECE	\$3.50	\$2.77	\$3.50	\$3.50	\$3.50	\$3.50	\$3.50	\$3.50	\$3.50
NRC - Electronic Svc Order, per LSR disconnect	SOMECE	NA	\$0.43	NA	NA	NA	NA	NA	NA	NA
Channel System - Incremental Cost - Manual Svc. Order vs. Electronic -1st	SOMAN	\$15.61	NA	\$14.91	NA	\$13.71	\$26.95	\$25.51	\$25.59	NA
Channel System - Incremental Cost - Manual Svc. Order vs. Electronic -Add'l	SOMAN	\$7.39	NA	\$6.63	NA	\$6.09	\$11.98	\$8.37	\$8.92	NA
Incremental Cost-Manual Svc. Order vs. Elect -Disconnect - 1st	SOMAN	\$71.76	NA	\$10.82	NA	\$9.94	\$16.97	NA	NA	NA
Incremental Cost-Manual Svc. Order vs. Elect -Disconnect - Add'l	SOMAN	\$52.03	NA	NA	NA	NA	NA	NA	NA	NA
DS1 Channelization (DS1 to DS0)										
per Channelized System (24 DS0) per month	MQ1	\$136.82	\$154.74	\$126.22	\$200.01	\$126.66	\$146.87	\$158.01	\$147.51	\$165.21
NRC - 1st	MQ1	\$197.98	\$183.57	\$200.39	\$302.82	\$184.35	\$271.52	\$228.01	\$220.89	\$197.21
NRC - Add'l	MQ1	\$123.12	\$126.16	\$124.93	\$184.20	\$114.94	\$164.56	\$141.88	\$137.15	\$119.99
NRC -1sr - Disconnect	MQ1	\$11.67	\$19.68	\$28.95	NA	\$28.86	\$36.38	\$34.55	NA	\$25.66
NRC -Add'l - Disconnect	MQ1	\$0.95	\$18.29	\$18.43	NA	\$18.37	\$22.82	\$21.14	NA	\$15.81
- Interface (COCI)										
per OCU-DP(data) card per month (2.4-64kbs)	1D1DD	\$1.66	\$2.22	\$1.06	\$2.94	\$1.94	\$2.86	\$2.03	\$2.34	\$2.46
NRC - 1st	1D1DD	\$12.05	\$13.26	\$12.15	\$15.86	\$11.18	\$15.85	\$12.39	\$12.05	\$12.61
NRC - Add'l	1D1DD	\$8.69	\$9.50	\$8.76	\$11.36	\$8.06	\$11.35	\$8.93	\$8.68	\$9.03
per BRITE card per month	UC1CA	\$3.41	\$3.86	\$3.41	\$4.04	\$4.18	\$3.88	\$3.76	\$4.21	\$3.33
NRC - 1st	UC1CA	\$12.05	\$13.26	\$12.15	\$15.86	\$12.29	\$15.85	\$15.76	\$12.05	\$12.61
NRC - Add'l	UC1CA	\$8.69	\$9.50	\$8.76	\$11.36	\$8.80	\$11.35	\$11.28	\$8.68	\$9.03

BELLSOUTH/LEVEL 3 RATES
NETWORK ELEMENTS
AND OTHER SERVICES

DESCRIPTION	USOC	AL	FL	GA	KY	LA	MS	NC	SC	TN
per VG card per month (DS0)	1D1VG	\$0.86	\$1.46	\$2.20	\$1.40	\$1.06	\$1.45	\$1.28	\$1.47	\$1.25
NRC - 1st	1D1VG	\$12.05	\$13.26	\$12.15	\$15.86	\$11.18	\$15.85	\$12.39	\$12.05	\$12.61
NRC - Add'l	1D1VG	\$8.69	\$9.50	\$8.76	\$11.36	\$8.06	\$11.35	\$8.93	\$8.68	\$9.03
NRC - Manual Svc Order, per LSR	SOMAN	NA	\$21.73	NA	\$19.99	NA	NA	NA	NA	\$19.99
NRC - Manual Svc Order, per LSR disconnect	SOMAN	NA	\$3.87	NA	NA	NA	NA	NA	NA	NA
NRC - Electronic Svc Order, per LSR	SOMEK	\$3.50	\$2.77	\$3.50	\$3.50	\$3.50	\$3.50	\$3.50	\$3.50	\$3.50
NRC - Electronic Svc Order, per LSR disconnect	SOMAN	NA	\$0.43	NA	NA	NA	NA	NA	NA	NA
Channel System - Incremental Cost - Manual Svc. Order vs. Electronic -1st	SOMAN	\$15.61	NA	\$14.91	NA	\$13.71	\$26.95	\$25.51	\$25.59	NA
Channel System - Incremental Cost - Manual Svc. Order vs. Electronic -Add'l	SOMAN	\$7.39	NA	\$6.63	NA	\$6.09	\$11.98	\$8.37	\$8.92	NA
Incremental Cost-Manual Svc. Order vs. Elect -Disconnect - 1st	SOMAN	\$30.18	NA	\$10.82	NA	\$9.94	\$16.97	NA	NA	NA
Incremental Cost-Manual Svc. Order vs. Elect -Disconnect - Add'l	SOMAN	\$18.86	NA	NA	NA	NA	NA	NA	NA	NA
UNBUNDLED DARK FIBER	USOC	AL	FL	GA	KY	LA	MS	NC	SC	TN
Dark Fiber - Interoffice (four fiber strands) per route mile or fraction thereof, per month	1L5DF	\$25.80	\$29.28	\$24.96	\$31.95	\$32.28	\$33.93	\$29.86	\$36.75	\$28.60
NRC - Per each four-fiber dark fiber arrangement - 1st	UDF14	\$1,739.00	\$1,289	\$1,737.00	\$1,741.00	\$1,746.00	\$1,741.00	\$1,738.00	\$1,747.00	\$1,742.00
NRC - Per each four-fiber dark fiber arrangement - Add'l	UDF14	\$563.09	\$277.98	\$562.39	\$563.75	\$565.20	\$563.79	\$562.82	\$565.53	\$564.08
NRC -Disconnect--1st	UDF14	NA	\$592.25	NA	NA	NA	NA	NA	NA	NA
NRC -Disconnect--Add'l	UDF14	NA	\$369.22	NA	NA	NA	NA	NA	NA	NA
Dark Fiber - Local Channel/Loop (four fiber strands) per route mile or fraction thereof, per month	1L5DC	\$70.82	\$59.03	\$54.63	\$49.07	\$64.72	\$71.55	\$56.47	\$100.37	\$60.06
NRC - Per each four-fiber dark fiber arrangement - 1st	UDFC4	\$1,739.00	\$1,289	\$1,737.00	\$1,741.00	\$1,746.00	\$1,741.00	\$1,738.00	\$1,747.00	\$1,742.00
NRC - Per each four-fiber dark fiber arrangement - Add'l	UDFC4	\$563.09	\$277.98	\$562.39	\$563.75	\$565.20	\$563.79	\$562.82	\$565.53	\$564.08
NRC -Disconnect--1st	UDFC4	NA	\$592.25	NA	NA	NA	NA	NA	NA	NA
NRC -Disconnect--Add'l	UDFC4	NA	\$369.22	NA	NA	NA	NA	NA	NA	NA

BELLSOUTH/LEVEL 3 RATES
NETWORK ELEMENTS
AND OTHER SERVICES

DESCRIPTION	USOC	AL	FL	GA	KY	LA	MS	NC	SC	TN
UNBUNDLED LOOP COMBINATIONS										
Unbundled Loop/Port Combinations (Note 4)										
MARKET RATES (INCLUDING ALL VERTICAL FEATURES) (Note 1)										
Density Zone 1 / Top 8 MSAs in BellSouth Region			Orlando, Ft. Lauderdale, Miami	Atlanta		New Orleans		Greensboro-Winston Salem-Highpoint/Charlotte-Gastonia-Rock Hill		Nashville
Customers with 4 or more DS0 Equivalent										
Currently Combined (Note2)										
2-Wire Voice Grade Loop with 2-Wire Line Port (Res. and Bus.)										
2-Wire Voice Grade Line Port (Res.), per month										
2-wire voice unbundled port - residence	UEPRL	NA	\$14.00	\$14.00	NA	\$14.00	NA	\$14.00	NA	\$14.00
2-wire voice unbundled port with caller ID - residence	UEPRC	NA	\$14.00	\$14.00	NA	\$14.00	NA	\$14.00	NA	\$14.00
2-wire voice unbundled port outgoing only - residence	UEPRO	NA	\$14.00	\$14.00	NA	\$14.00	NA	\$14.00	NA	\$14.00
2-wire voice unbundled area plus port with caller ID - residence	UEPRM	NA	\$14.00	\$14.00	NA	\$14.00	NA	\$14.00	NA	\$14.00
2-wire voice unbundled Florida area calling with caller ID - residence	UEPAF	NA	\$14.00	NA	NA	NA	NA	NA	NA	NA
2-wire voice unbundled Louisiana Area Plus with caller ID - residence (RUL)	UEPAG	NA	NA	NA	NA	\$14.00	NA	NA	NA	NA
2-wire voice unbundled Louisiana Area Plus with caller ID - residence (AC7)	UEPAH	NA	NA	NA	NA	\$14.00	NA	NA	NA	NA
2-wire voice unbundled South Carolina Area Calling port with Caller ID - residence (LW8)	UEPAJ	NA	NA	NA	NA	NA	NA	NA	NA	NA
2-wire voice unbundled Tennessee Area Calling port with Caller ID - residence (F2R)	UEPAK	NA	NA	NA	NA	NA	NA	NA	NA	\$14.00
2-wire voice unbundled Tennessee Area Calling port with Caller ID - residence (TACER)	UEPAL	NA	NA	NA	NA	NA	NA	NA	NA	\$14.00
2-wire voice unbundled Tennessee Area Calling port with Caller ID - residence (TACSR)	UEPAM	NA	NA	NA	NA	NA	NA	NA	NA	\$14.00
2-wire voice unbundled Tennessee Area Calling port with Caller ID - residence (1MF2X)	UEPAN	NA	NA	NA	NA	NA	NA	NA	NA	\$14.00
2-wire voice unbundled Tennessee Area Calling port with Caller ID - residence (2MR)	UEPAO	NA	NA	NA	NA	NA	NA	NA	NA	\$14.00
2-wire voice unbundled res, low usage line port with Caller ID (LUM)	UEPAP	NA	\$14.00	\$14.00	NA	\$14.00	NA	\$14.00	NA	\$14.00
2-Wire Voice Grade Line Port (Bus.), per month										
2-wire voice unbundled port without Caller ID	UEPBL	NA	\$14.00	\$14.00	NA	\$14.00	NA	\$14.00	NA	\$14.00
2-wire voice unbundled port with unbundled port with Caller+E484 ID	UEPBC	NA	\$14.00	\$14.00	NA	\$14.00	NA	\$14.00	NA	\$14.00
2-wire voice unbundled outgoing only port	UEPBO	NA	\$14.00	\$14.00	NA	\$14.00	NA	\$14.00	NA	\$14.00
2-wire voice unbundled area plus port with Caller ID	UEPBM	NA	\$14.00	\$14.00	NA	\$14.00	NA	\$14.00	NA	\$14.00
2-wire voice unbundled incoming only port with Caller ID	UEPB1	NA	\$14.00	\$14.00	NA	\$14.00	NA	\$14.00	NA	\$14.00
2-wire voice unbundled LA Bus Area Calling Port with Caller ID (BUC)	UEPAA	NA	NA	NA	NA	\$14.00	NA	NA	NA	NA
2-wire voice unbundled SC Bus Area Calling Port with Caller ID (LMB)	UEPAB	NA	NA	NA	NA	NA	NA	NA	NA	NA
2-wire voice unbundled TN Bus 2-Way Area Calling Port Economy Option (TACC1)	UEPAC	NA	NA	NA	NA	NA	NA	NA	NA	\$14.00
2-wire voice unbundled TN Bus 2-Way Area Calling Port Standard Option (TACC2)	UEPAD	NA	NA	NA	NA	NA	NA	NA	NA	\$14.00
2-wire voice unbundled TN Bus 2-WAY Collierville and Memphis Local Calling Port (B2F)	UEPAE	NA	NA	NA	NA	NA	NA	NA	NA	\$14.00
2-Wire Voice Grade Loop (SL1) (Res. and Bus.)										
RC - 2-Wire Voice Grade Loop - Statewide	UEPLX	NA	NA	NA	NA	NA	NA	\$14.18	NA	NA
RC - 2-Wire Voice Grade Loop Zone 1	UEPLX	NA	\$13.75	\$10.80	NA	\$14.05	NA	NA	NA	\$15.92
RC - 2-Wire Voice Grade Loop Zone 2	UEPLX	NA	\$20.13	\$12.47	NA	\$24.14	NA	NA	NA	\$20.79
RC - 2-Wire Voice Grade Loop Zone 3	UEPLX	NA	\$44.40	\$19.83	NA	\$49.30	NA	NA	NA	\$27.18
Combination Rates										
RC - 2-Wire Voice Grade Loop with 2-Wire Line Port, Statewide	Note 8	NA	NA	NA	NA	NA	NA	\$28.18	NA	NA
RC - 2-Wire Voice Grade Loop with 2-Wire Line Port, Zone 1 (Note 6)	Note 8	NA	\$27.75	\$24.80	NA	\$28.05	NA	NA	NA	\$29.92
RC - 2-Wire Voice Grade Loop with 2-Wire Line Port, Zone 2 (Note 6)	Note 8	NA	\$34.13	\$26.47	NA	\$38.14	NA	NA	NA	\$34.79
RC - 2-Wire Voice Grade Loop with 2-Wire Line Port, Zone 3 (Note 6)	Note 8	NA	\$58.40	\$33.83	NA	\$63.30	NA	NA	NA	\$41.18

BELLSOUTH/LEVEL 3 RATES
NETWORK ELEMENTS
AND OTHER SERVICES

DESCRIPTION	USOC	AL	FL	GA	KY	LA	MS	NC	SC	TN
NRC - 2-Wire Voice Grade Loop/Line Port Combination - 1st, Switch as is	TBD	NA	\$41.50	\$41.50	NA	\$41.50	NA	\$41.50	NA	\$41.50
NRC - 2-Wire Voice Grade Loop/Line Port Combination - Add'l, Switch as is	TBD	NA	\$41.50	\$41.50	NA	\$41.50	NA	\$41.50	NA	\$41.50
NRC - 2-Wire Voice Grade Loop/Line Port Combination - 1st, Switch with change	TBD	NA	\$41.50	\$41.50	NA	\$41.50	NA	\$41.50	NA	\$41.50
NRC - 2-Wire Voice Grade Loop/Line Port Combination - Add'l, Switch with change	TBD	NA	\$41.50	\$41.50	NA	\$41.50	NA	\$41.50	NA	\$41.50
NRC - 2-Wire Voice Grade Loop/Line Port Combination - Subsequent	TBD	NA	\$10.00	\$10.00	NA	\$10.00	NA	\$10.00	NA	\$10.00
NRC - 2-Wire Voice Grade Loop/Line Port Combination - OSS LSR Charge, Electronic, per LSR received from the CLEC by one of the OSS interactive interfaces	SOME C	NA	\$3.50	\$3.50	NA	\$3.50	NA	\$3.50	NA	\$3.50
NRC - 2-Wire Voice Grade Loop/Line Port Combination - Incremental Cost - Manual Svc.Order vs. Electronic - 1st	SOMAN	NA	\$19.99	\$33.76	NA	\$31.92	NA	\$40.18	NA	\$30.89
NRC - 2-Wire Voice Grade Loop/Line Port Combination - Incremental Cost - Manual Svc.Order vs. Electronic - Add'l	SOMAN	NA	\$19.99	\$7.86	NA	\$7.32	NA	\$9.45	NA	\$7.03
NRC - 2 Wire Voice Grade Loop/Line Port Combination - Subsequent Database Update - Electronic	TBD	NA	TBD	TBD	NA	\$2.11	NA	\$1.42	NA	TBD
NRC - 2 Wire Voice Grade Loop/Line Port Combination - Subsequent Database Update - Manual Service Order	TBD	NA	TBD	TBD	NA	\$5.12	NA	\$10.27	NA	TBD
NRC - Incremental Manual Service Order Disconnect	TBD	NA	\$20.00	\$20.00	NA	\$20.00	NA	\$20.00	NA	\$20.00
2- Wire Voice Grade Loop - Bus Only with 2-Wire DID Trunk Port										
2 - Wire Line Port - DID Trunk Port, per month	UEPD1	NA	TBD	TBD	NA	TBD	NA	TBD	NA	TBD
2-Wire Voice Grade Loop (SL2)										
RC - 2-Wire Voice Grade Loop - Statewide	UECD1	NA	NA	NA	NA	NA	NA	\$11.76	NA	NA
RC - 2-Wire Voice Grade Loop Zone 1	UECD1	NA	\$18.28	\$16.84	NA	\$17.65	NA	NA	NA	\$15.92
RC - 2-Wire Voice Grade Loop Zone 2	UECD1	NA	\$22.34	\$19.45	NA	\$30.32	NA	NA	NA	\$20.79
RC - 2-Wire Voice Grade Loop Zone 3	UECD1	NA	\$27.97	\$30.92	NA	\$61.93	NA	NA	NA	\$27.18
Combination Rates										
RC - 2-Wire Voice Grade Loop with 2-Wire DID Port, Statewide	Note 8	NA	TBD	TBD	NA	TBD	NA	TBD	NA	TBD
RC - 2-Wire Voice Grade Loop with 2-Wire DID Port, Zone 1 (Note 6)	Note 8	NA	TBD	TBD	NA	TBD	NA	NA	NA	TBD
RC - 2-Wire Voice Grade Loop with 2-Wire DID Port, Zone 2 (Note 6)	Note 8	NA	TBD	TBD	NA	TBD	NA	NA	NA	TBD
RC - 2-Wire Voice Grade Loop with 2-Wire DID Port, Zone 3 (Note 6)	Note 8	NA	TBD	TBD	NA	TBD	NA	NA	NA	TBD
NRC - 2- Wire Voice Grade Loop with 2- Wire Line Port - 1st	TBD	NA	TBD	TBD	NA	TBD	NA	TBD	NA	TBD
NRC - 2- Wire Voice Grade Loop with 2- Wire Line Port - Add'l	TBD	NA	TBD	TBD	NA	TBD	NA	TBD	NA	TBD
NRC - 2-Wire Voice Grade Loop/Line Port Combination - OSS LSR Charge, Electronic, per LSR received from the CLEC by one of the OSS interactive interfaces (Note 7)	SOME C	NA	\$3.50	\$3.50	NA	\$3.50	NA	\$3.50	NA	\$3.50
NRC - 2- Wire Voice Grade Loop with 2- Wire Line Port - Incremental Cost- Manual Service Order - 1st	TBD	NA	TBD	TBD	NA	TBD	NA	TBD	NA	TBD
NRC - 2- Wire Voice Grade Loop with 2- Wire Line Port - Incremental Cost- Manual Service Order - Add'l	TBD	NA	TBD	TBD	NA	TBD	NA	TBD	NA	TBD
2-Wire ISDN Digital Grade Loop with 2-wire ISDN Digital Port										
2-wire ISDN Digital Port, per month	UEPPB	NA	TBD	TBD	NA	TBD	NA	TBD	NA	TBD
2-Wire ISDN Digital Grade Loop										
RC - 2-Wire ISDN Digital Grade Loop - Statewide	USL2X	NA	NA	NA	NA	NA	NA	\$19.08	NA	NA
RC - 2-Wire ISDN Digital Grade Loop - Zone 1	USL2X	NA	\$32.34	\$21.89	NA	\$21.15	NA	NA	NA	\$15.92
RC - 2-Wire ISDN Digital Grade Loop - Zone 2	USL2X	NA	\$47.35	\$25.27	NA	\$36.32	NA	NA	NA	\$20.79
RC - 2-Wire ISDN Digital Grade Loop - Zone 3	USL2X	NA	\$104.47	\$40.17	NA	\$74.19	NA	NA	NA	\$27.18
Combination Rates										
RC - 2-Wire ISDN Digital Grade Loop with 2-wire ISDN Digital Port - Statewide	Note 8	NA	NA	NA	NA	NA	NA	NA	NA	NA
RC - 2-Wire ISDN Digital Grade Loop with 2-wire ISDN Digital Port - Zone 1	Note 8	NA	TBD	TBD	NA	TBD	NA	TBD	NA	TBD
RC - 2-Wire ISDN Digital Grade Loop with 2-wire ISDN Digital Port - Zone 2	Note 8	NA	TBD	TBD	NA	TBD	NA	TBD	NA	TBD
RC - 2-Wire ISDN Digital Grade Loop with 2-wire ISDN Digital Port - Zone 3	Note 8	NA	TBD	TBD	NA	TBD	NA	TBD	NA	TBD
NRC - 2-Wire ISDN Digital Grade Loop/2-wire ISDN Digital Port - 1st conversion	USACB	NA	TBD	TBD	NA	TBD	NA	TBD	NA	TBD

BELLSOUTH/LEVEL 3 RATES
NETWORK ELEMENTS
AND OTHER SERVICES

DESCRIPTION	USOC	AL	FL	GA	KY	LA	MS	NC	SC	TN
NRC - 2-Wire ISDN Digital Grade Loop/2-wire ISDN Digital Port - Add'l conversion	USACB	NA	TBD	TBD	NA	TBD	NA	TBD	NA	TBD
NRC - 2-Wire ISDN Digital Grade Loop/2-wire ISDN Digital Port - Non Feature Subsequent Activity	USASB	NA	TBD	TBD	NA	TBD	NA	TBD	NA	TBD
NRC - 2-Wire Voice Grade Loop/Line Port Combination - OSS LSR Charge, Electronic, per LSR received from the CLEC by one of the OSS interactive interfaces (Note 7)	SOME C	NA	\$3.50	\$3.50	NA	\$3.50	NA	\$3.50	NA	\$3.50
4 - Wire DS1 Digital Loop with 4 - Wire ISDN DS1 Digital Trunk Port										
4 - Wire ISDN DS1 Digital Trunk Port	UEPPP	NA	TBD	TBD	NA	TBD	NA	TBD	NA	TBD
4 - Wire DS1 Digital Loop		NA								
RC - 4- Wire DS1 Digital Loop- Statewide	USL4P	NA	NA	NA	NA	NA	NA	\$62.71	NA	NA
RC - 4- Wire DS1 Digital Loop- Zone 1	USL4P	NA	\$64.69	\$55.53	NA	\$56.32	NA	NA	NA	\$57.73
RC - 4- Wire DS1 Digital Loop- Zone 2	USL4P	NA	\$94.71	\$64.13	NA	\$96.73	NA	NA	NA	\$75.40
RC - 4- Wire DS1 Digital Loop- Zone 3	USL4P	NA	\$208.93	\$101.93	NA	\$197.57	NA	NA	NA	\$98.59
Combination Rates										
RC - 4-Wire DS1 Digital Loop with 4-wire ISDN DS1 Digital Port - Statewide	Note 8	NA	NA	NA	NA	NA	NA	TBD	NA	NA
RC - 4-Wire DS1 Digital Loop with 4-wire ISDN DS1 Digital Port - Zone 1	Note 8	NA	TBD	TBD	NA	TBD	NA	NA	NA	TBD
RC - 4-Wire DS1 Digital Loop with 4-wire ISDN DS1 Digital Port - Zone 2	Note 8	NA	TBD	TBD	NA	TBD	NA	NA	NA	TBD
RC - 4-Wire DS1 Digital Loop with 4-wire ISDN DS1 Digital Port - Zone 3	Note 8	NA	TBD	TBD	NA	TBD	NA	NA	NA	TBD
NRC - 4-Wire DS1 Digital Loop with 4-wire ISDN DS1 Digital Port Combination - 1st conversion	TBD	NA	TBD	TBD	NA	TBD	NA	TBD	NA	TBD
NRC - 4-Wire DS1 Digital Loop with 4-wire ISDN DS1 Digital Port Combination - Add'l conversion	TBD	NA	TBD	TBD	NA	TBD	NA	TBD	NA	TBD
NRC -4 - Wire DS1 Digital Loop with 4 - Wire ISDN DS1 Digital Trunk Port - Subsequent Channel Activation - Per Channel	TBD	NA	TBD	TBD	NA	TBD	NA	TBD	NA	TBD
NRC -4 - Wire DS1 Digital Loop with 4 - Wire ISDN DS1 Digital Trunk Port - Subsequent Inward/2way Telephone Numbers	TBD	NA	TBD	TBD	NA	TBD	NA	TBD	NA	TBD
NRC -4 - Wire DS1 Digital Loop with 4 - Wire ISDN DS1 Digital Trunk Port - Subsequent Outward Telephone Numbers	TBD	NA	TBD	TBD	NA	TBD	NA	TBD	NA	TBD
NRC -4 - Wire DS1 Digital Loop with 4 - Wire ISDN DS1 Digital Trunk Port - Subsequent Inward Telephone Numbers	TBD	NA	TBD	TBD	NA	TBD	NA	TBD	NA	TBD
NRC -4 - Wire DS1 Digital Loop with 4 - Wire ISDN DS1 Digital Trunk Port - Subsequent Service Order Per Order	TBD	NA	TBD	TBD	NA	TBD	NA	TBD	NA	TBD
NRC - 2-Wire Voice Grade Loop/Line Port Combination - OSS LSR Charge, Electronic, per LSR received from the CLEC by one of the OSS interactive interfaces (Note 7)	SOME C	NA	\$3.50	\$3.50	\$3.50	\$3.50	\$3.50	\$3.50	\$3.50	\$3.50
4 - Wire DS1 Digital Loop with 4 - Wire DID Trunk Port										
4 - Wire DID Trunk Port	TBD	NA	TBD	TBD	NA	TBD	NA	TBD	NA	TBD
4 - Wire DS1 Digital Loop										
RC - 4- Wire DS1 Digital Loop- Statewide	TBD	NA	NA	NA	NA	NA	NA	\$62.71	NA	NA
RC - 4- Wire DS1 Digital Loop- Zone 1	TBD	NA	\$64.69	\$55.53	NA	\$56.32	NA	NA	NA	\$57.73
RC - 4- Wire DS1 Digital Loop- Zone 2	TBD	NA	\$94.71	\$64.13	NA	\$96.73	NA	NA	NA	\$75.40
RC - 4- Wire DS1 Digital Loop- Zone 3	TBD	NA	\$208.93	\$101.93	NA	\$197.57	NA	NA	NA	\$98.59
RC - 4-Wire DS1 Digital Loop with 4-wire DID Trunk Port - Statewide	Note 8	NA	NA	NA	NA	NA	NA	TBD	NA	NA
RC - 4-Wire DS1 Digital Loop with 4-wire DID Trunk Port - Zone 1	Note 8	NA	TBD	TBD	NA	TBD	NA	NA	NA	TBD
RC - 4-Wire DS1 Digital Loop with 4-wire DID Trunk Port - Zone 2	Note 8	NA	TBD	TBD	NA	TBD	NA	NA	NA	TBD
RC - 4-Wire DS1 Digital Loop with 4-wire DID Trunk Port - Zone 3	Note 8	NA	TBD	TBD	NA	TBD	NA	NA	NA	TBD
NRC -4 - Wire DS1 Digital Loop with 4 - Wire DID Trunk Port - 1st	TBD	NA	TBD	TBD	NA	TBD	NA	TBD	NA	TBD
NRC -4 - Wire DS1 Digital Loop with 4 - Wire ISDN DS1 Digital Trunk Port - Add'l	TBD	NA	TBD	TBD	NA	TBD	NA	TBD	NA	TBD
NRC -4 - Wire DS1 Digital Loop with 4 - Wire DID Trunk Port - Subsequent Channel Activation - Per Channel	TBD	NA	TBD	TBD	NA	TBD	NA	TBD	NA	TBD
NRC -4 - Wire DS1 Digital Loop with 4 - Wire ISDN DS1 Digital Trunk Port - Subsequent Telephone Numbers	TBD	NA	TBD	TBD	NA	TBD	NA	TBD	NA	TBD
NRC -4 - Wire DS1 Digital Loop with 4 - Wire ISDN DS1 Digital Trunk Port - Subsequent Signaling Changes	TBD	NA	TBD	TBD	NA	TBD	NA	TBD	NA	TBD

BELLSOUTH/LEVEL 3 RATES
NETWORK ELEMENTS
AND OTHER SERVICES

DESCRIPTION	USOC	AL	FL	GA	KY	LA	MS	NC	SC	TN
NRC -4 - Wire DS1 Digital Loop with 4 - Wire ISDN DS1 Digital Trunk Port - Subsequent Service Order Per Order	TBD	NA	TBD	TBD	NA	TBD	NA	TBD	NA	TBD
NRC - 2-Wire Voice Grade Loop/Line Port Combination - OSS LSR Charge, Electronic, per LSR received from the CLEC by one of the OSS interactive interfaces (Note 7)	SOME C	NA	\$3.50	\$3.50	\$3.50	\$3.50	\$3.50	\$3.50	\$3.50	\$3.50
2-Wire Voice Grade Loop with 2-Wire Line Port PBX										
2-Wire Analog Line Port (PBX), per month										
2 WIRE VOICE UNBUNDLED COMBINATION 2-WAY PBX TRUNK - Residence	UEPRD	NA	\$14.00	\$14.00	NA	\$14.00	NA	\$14.00	NA	\$14.00
LINE SIDE UNBUNDLED COMBINATION 2-WAY PBX TRUNK - BUSINESS	UEPPC	NA	\$14.00	\$14.00	NA	\$14.00	NA	\$14.00	NA	\$14.00
LINE SIDE UNBUNDLED OUTWARD PBX TRUNK - BUSINESS	UEPPO	NA	\$14.00	\$14.00	NA	\$14.00	NA	\$14.00	NA	\$14.00
LINE SIDE UNBUNDLED INCOMING PBX TRUNK - BUSINESS	UEPP1	NA	\$14.00	\$14.00	NA	\$14.00	NA	\$14.00	NA	\$14.00
2-WIRE VOICE UNBUNDLED 2-WAY COMBINATION PBX ALABAMA CALLING PORT	UEPA2	NA	NA	NA	NA	NA	NA	NA	NA	NA
2-WIRE VOICE UNBUNDLED 2-WAY COMBINATION PBX LOUISIANA CALLING PORT	UEPL2	NA	NA	NA	NA	\$14.00	NA	NA	NA	NA
2-WIRE VOICE UNBUNDLED PBX LD TERMINAL PORTS	UEPLD	NA	\$14.00	\$14.00	NA	\$14.00	NA	\$14.00	NA	\$14.00
2-WIRE VOICE UNBUNDLED 2-WAY COMBINATION PBX TENNESSEE CALLING PORT	UEPT2	NA	NA	NA	NA	NA	NA	NA	NA	\$14.00
2-WIRE VOICE UNBUNDLED 1-WAY OUTGOING PBX TENNESSEE CALLING PORT	UEPTO	NA	NA	NA	NA	NA	NA	NA	NA	\$14.00
2-WIRE VOICE UNBUNDLED 2-WAY COMBINATION PBX USAGE PORT	UEPXA	NA	\$14.00	\$14.00	NA	\$14.00	NA	\$14.00	NA	\$14.00
2-WIRE VOICE UNBUNDLED PBX TOLL TERMINAL HOTEL PORTS	UEPXB	NA	\$14.00	\$14.00	NA	\$14.00	NA	\$14.00	NA	\$14.00
2-WIRE VOICE UNBUNDLED PBX LD DDD TERMINALS PORT	UEPXC	NA	\$14.00	\$14.00	NA	\$14.00	NA	\$14.00	NA	\$14.00
2-WIRE VOICE UNBUNDLED PBX LD TERMINAL SWITCHBOARD PORT	UEPXD	NA	\$14.00	\$14.00	NA	\$14.00	NA	\$14.00	NA	\$14.00
2-WIRE VOICE UNBUNDLED PBX LD TERMINAL SWITCHBOARD IDD CAPABLE PORT	UEPXE	NA	\$14.00	\$14.00	NA	\$14.00	NA	\$14.00	NA	\$14.00
2-WIRE VOICE UNBUNDLED 2-WAY PBX KENTUCKY ROOM AREA CALLING PORT WITHOUT LUD	UEPXF	NA	NA	NA	NA	NA	NA	NA	NA	NA
2-WIRE VOICE UNBUNDLED PBX KENTUCKY LUD AREA CALLING PORT	UEPXG	NA	NA	NA	NA	NA	NA	NA	NA	NA
2-WIRE VOICE UNBUNDLED PBX KENTUCKY PREMIUM CALLING PORT	UEPXH	NA	NA	NA	NA	NA	NA	NA	NA	NA
2-WIRE VOICE UNBUNDLED 2-WAY KENTUCKY AREA CALLING PORT WITHOUT LUD	UEPXJ	NA	NA	NA	NA	NA	NA	NA	NA	NA
2-WIRE VOICE UNBUNDLED 2-WAY PBX LOUISIANA LOCAL OPTIONAL CALLING PORT	UEPXK	NA	NA	NA	NA	\$14.00	NA	NA	NA	NA
2-WIRE VOICE UNBUNDLED 2-WAY PBX HOTEL/HOSPITAL ECONOMY ADMINISTRATIVE CALLING PORT	UEPXL	NA	\$14.00	\$14.00	NA	\$14.00	NA	\$14.00	NA	\$14.00
2-WIRE VOICE UNBUNDLED 2-WAY PBX HOTEL/HOSPITAL ECONOMY ROOM CALLING PORT	UEPXM	NA	\$14.00	\$14.00	NA	\$14.00	NA	\$14.00	NA	\$14.00
2-WIRE VOICE UNBUNDLED 1-WAY OUTGOING PBX HOTEL/HOSPITAL ECONOMY ADMINISTRATIVE CALLING PORT TENNESSEE CALLING PORT	UEPXN	NA	NA	NA	NA	NA	NA	NA	NA	\$14.00
2-WIRE VOICE UNBUNDLED 1-WAY OUTGOING PBX HOTEL/HOSPITAL DISCOUNT ROOM CALLING PORT	UEPXO	NA	\$14.00	\$14.00	NA	\$14.00	NA	\$14.00	NA	\$14.00
2-WIRE VOICE UNBUNDLED 1-WAY OUTGOING PBX LOUISIANA LOCAL DISCOUNT CALLING PORT	UEPXP	NA	NA	NA	NA	\$14.00	NA	NA	NA	NA
2-WIRE VOICE UNBUNDLED 2-WAY PBX MISSISSIPPI LOCAL ECONOMY CALLING PORT	UEPXQ	NA	NA	NA	NA	NA	NA	NA	NA	NA
2-WIRE VOICE UNBUNDLED 2-WAY PBX MISSISSIPPI LOCAL OPTIONAL CALLING PORT	UEPXR	NA	NA	NA	NA	NA	NA	NA	NA	NA
2-WIRE VOICE UNBUNDLED 1-WAY OUTGOING PBX MEASURED PORT	UEPXS	NA	\$14.00	\$14.00	NA	\$14.00	NA	\$14.00	NA	\$14.00
2-WIRE VOICE UNBUNDLED 2-WAY PBX SOUTH CAROLINA AREA PLUS CALLING PORT	UEPXT	NA	NA	NA	NA	NA	NA	NA	NA	NA
2-WIRE VOICE UNBUNDLED PBX COLLIERVILLE & MEMPHIS CALLING PORT	UEPXU	NA	NA	NA	NA	NA	NA	NA	NA	\$14.00
2-WIRE VOICE UNBUNDLED 2-WAY PBX TENNESSEE REGIONSERV CALLING PORT	UEPXV	NA	NA	NA	NA	NA	NA	NA	NA	\$14.00
LOCAL NUMBER PORTABILITY (REQUIRES ONE PER PORT)	LNPCP									

BELLSOUTH/LEVEL 3 RATES
NETWORK ELEMENTS
AND OTHER SERVICES

DESCRIPTION	USOC	AL	FL	GA	KY	LA	MS	NC	SC	TN
2-Wire Voice Grade Loop (SL1)										
RC - 2- Wire Voice Grade Loop - Statewide	UEPLX	NA	NA	NA	NA	NA	NA	\$14.18	NA	NA
RC - 2- Wire Voice Grade Loop - Zone 1	UEPLX	NA	\$13.75	\$10.80	NA	\$14.05	NA	NA	NA	\$15.92
RC - 2- Wire Voice Grade Loop - Zone 2	UEPLX	NA	\$20.13	\$12.47	NA	\$24.14	NA	NA	NA	\$20.79
RC - 2- Wire Voice Grade Loop - Zone 3	UEPLX	NA	\$44.40	\$19.83	NA	\$49.30	NA	NA	NA	\$27.18
RC - 2- Wire Voice Grade Loop - Zone 4	UEPLX	NA	NA	NA	NA	NA	NA	NA	NA	NA
Combination Rates										
RC - 2-Wire Voice Grade Loop with 2-Wire Line Port, Statewide	Note 8	NA	NA	NA	NA	NA	NA	\$28.18	NA	NA
RC - 2-Wire Voice Grade Loop with 2-Wire Line Port, Zone 1 (Note 6)	Note 8	NA	\$27.75	\$24.80	NA	\$28.05	NA	NA	NA	\$29.92
RC - 2-Wire Voice Grade Loop with 2-Wire Line Port, Zone 2 (Note 6)	Note 8	NA	\$34.13	\$26.47	NA	\$38.14	NA	NA	NA	\$34.79
RC - 2-Wire Voice Grade Loop with 2-Wire Line Port, Zone 3 (Note 6)	Note 8	NA	\$58.40	\$33.83	NA	\$63.30	NA	NA	NA	\$41.18
NRC - 2-Wire Voice Grade Loop/Line Port Combination - 1st, Switch as is	TBD	NA	\$41.50	\$41.50	NA	\$41.50	NA	\$41.50	NA	\$41.50
NRC - 2-Wire Voice Grade Loop/Line Port Combination - Add'l, Switch as is	TBD	NA	\$41.50	\$41.50	NA	\$41.50	NA	\$41.50	NA	\$41.50
NRC - 2-Wire Voice Grade Loop/Line Port Combination - 1st, Switch with change	TBD	NA	\$41.50	\$41.50	NA	\$41.50	NA	\$41.50	NA	\$41.50
NRC - 2-Wire Voice Grade Loop/Line Port Combination - Add'l, Switch with change	TBD	NA	\$41.50	\$41.50	NA	\$41.50	NA	\$41.50	NA	\$41.50
NRC - 2-Wire Voice Grade Loop/Line Port Combination - Subsequent	TBD	NA	\$10.00	\$10.00	\$10.00	\$10.00	NA	\$10.00	NA	\$10.00
NRC - 2-Wire Voice Grade Loop/Line Port Combination - OSS LSR Charge, Electronic, per LSR received from the CLEC by one of the OSS interactive interfaces (Note 7)	SOME C	NA	\$3.50	\$3.50	NA	\$3.50	NA	\$3.50	NA	\$3.50
NRC - 2-Wire Voice Grade Loop/Line Port Combination - Incremental Cost - Manual Svc.Order vs. Electronic - 1st	SOMAN	NA	\$19.99	\$33.67	NA	\$31.92	NA	\$40.18	NA	\$30.89
NRC - 2-Wire Voice Grade Loop/Line Port Combination - Incremental Cost - Manual Svc.Order vs. Electronic - Add'l	SOMAN	NA	\$19.99	\$7.88	NA	\$7.32	NA	\$9.45	NA	\$7.03
NRC - 2 Wire Voice Grade Loop/Line Port Combination - Subsequent Database Update - Electronic	TBD	NA	TBD	TBD	NA	\$2.11	NA	\$1.42	NA	TBD
NRC - 2 Wire Voice Grade Loop/Line Port Combination - Subsequent Database Update - Manual Service Order	TBD	NA	TBD	TBD	NA	\$5.12	NA	\$10.27	NA	TBD
NRC - Incremental Manual Service Order Disconnect	TBD	NA	\$20.00	\$20.00	NA	\$20.00	NA	\$20.00	NA	\$20.00
NRCs for New (not Currently Combined) in Georgia:										
NRC - 2-Wire Voice Grade Loop/Line Port Combination - 1st	TBD	NA	NA	\$90.00	NA	NA	NA	NA	NA	NA
NRC - 2-Wire Voice Grade Loop/Line Port Combination - Add'l	TBD	NA	NA	\$90.00	NA	NA	NA	NA	NA	NA
NRC - 2-Wire Voice Grade Loop/Line Port Combination - Subsequent	TBD	NA	NA	\$10.00	NA	NA	NA	NA	NA	NA
NRC - 2-Wire Voice Grade Loop with 2-Wire Line Port - New - Disconnect - 1st	TBD	NA	NA	\$8.45	NA	NA	NA	NA	NA	NA
NRC - 2-Wire Voice Grade Loop with 2-Wire Line Port - New - Disconnect - Add'l	TBD	NA	NA	\$3.91	NA	NA	NA	NA	NA	NA
NRC - 2-Wire Voice Grade Loop/Line Port Combination - OSS LSR Charge, Electronic, per LSR received from the CLEC by one of the OSS interactive interfaces	SOME C	NA	NA	\$3.50	NA	NA	NA	NA	NA	NA
NRC - 2-Wire Voice Grade Loop with 2-Wire Line Port - Incremental Cost Manual vs. Electronic - New - 1st	TBD	NA	NA	\$37.06	NA	NA	NA	NA	NA	NA
NRC - 2-Wire Voice Grade Loop with 2-Wire Line Port - Incremental Cost Manual vs. Electronic - New - Add'l	TBD	NA	NA	\$8.19	NA	NA	NA	NA	NA	NA
NRC - 2 Wire Voice Grade Loop/Line Port Combination - Subsequent Database Update - Electronic	TBD	NA	NA	TBD	NA	NA	NA	NA	NA	NA
NRC - 2 Wire Voice Grade Loop/Line Port Combination - Subsequent Database Update - Manual Service Order	TBD	NA	NA	TBD	NA	NA	NA	NA	NA	NA
NRC - 2-Wire Voice Grade Loop with 2-Wire Line Port - Incremental Cost Manual vs. Electronic - New - Disconnect	TBD	NA	NA	\$11.17	NA	NA	NA	NA	NA	NA
COST BASED RATES (Notes 2 & 3)										
Currently Combined										
2-Wire Voice Grade Loop with 2-Wire Line Port										
2-Wire Voice Grade Line Port (Res.), per month										
2- wire voice unbundled port - residence	UEPRL	\$2.20	\$2.00	\$1.79	\$2.61	\$2.55	\$2.12	\$2.28	\$3.69	\$1.90
2-wire voice unbundled port with caller ID - residence	UEPRC	\$2.20	\$2.00	\$1.79	\$2.61	\$2.55	\$2.12	\$2.28	\$3.69	\$1.90
2-wire voice unbundled port outgoing only - residence	UEPRO	\$2.20	\$2.00	\$1.79	\$2.61	\$2.55	\$2.12	\$2.28	\$3.69	\$1.90

BELLSOUTH/LEVEL 3 RATES
NETWORK ELEMENTS
AND OTHER SERVICES

DESCRIPTION	USOC	AL	FL	GA	KY	LA	MS	NC	SC	TN
2-wire voice unbundled area plus port with caller ID - residence	UEPRM	\$2.20	\$2.00	\$1.79	\$2.61	\$2.55	\$2.12	\$2.28	\$3.69	\$1.90
2-wire voice unbundled Florida area calling with caller ID - residence	UEPAF	NA	\$2.00	NA	NA	NA	NA	NA	NA	NA
2-wire voice unbundled Louisiana Area Plus with caller ID - residence (RUL)	UEPAG	NA	NA	NA	NA	\$2.55	NA	NA	NA	NA
2-wire voice unbundled Louisiana Area Plus with caller ID - residence (AC7)	UEPAH	NA	NA	NA	NA	\$2.55	NA	NA	NA	NA
2-wire voice unbundled South Carolina Area Calling port with Caller ID - residence (LW8)	UEPAJ	NA	NA	NA	NA	NA	NA	NA	\$3.69	NA
2-wire voice unbundled Tennessee Area Calling port with Caller ID - residence (F2R)	UEPAK	NA	NA	NA	NA	NA	NA	NA	NA	\$1.90
2-wire voice unbundled Tennessee Area Calling port with Caller ID - residence (TACER)	UEPAL	NA	NA	NA	NA	NA	NA	NA	NA	\$1.90
2-wire voice unbundled Tennessee Area Calling port with Caller ID - residence (TACSR)	UEPAM	NA	NA	NA	NA	NA	NA	NA	NA	\$1.90
2-wire voice unbundled Tennessee Area Calling port with Caller ID - residence (1MF2X)	UEPAN	NA	NA	NA	NA	NA	NA	NA	NA	\$1.90
2-wire voice unbundled Tennessee Area Calling port with Caller ID - residence (2MR)	UEPAO	NA	NA	NA	NA	NA	NA	NA	NA	\$1.90
2-wire voice unbundled res, low usage line port with Caller ID (LUM)	UEPAP	\$2.20	\$2.00	\$1.79	\$2.61	\$2.55	\$2.12	\$2.28	\$3.69	\$1.90
2-Wire Voice Grade Line Port (Bus.), per month										
2-wire voice unbundled port without Caller ID	UEPBL	\$2.20	\$2.00	\$1.79	\$2.61	\$2.55	\$2.12	\$2.28	\$3.69	\$1.90
2-wire voice unbundled port with unbundled port with Caller+E484 ID	UEPBC	\$2.20	\$2.00	\$1.79	\$2.61	\$2.55	\$2.12	\$2.28	\$3.69	\$1.90
2-wire voice unbundled outgoing only port	UEPBO	\$2.20	\$2.00	\$1.79	\$2.61	\$2.55	\$2.12	\$2.28	\$3.69	\$1.90
2-wire voice unbundled area plus port with Caller ID	UEPBM	\$2.20	\$2.00	\$1.79	\$2.61	\$2.55	\$2.12	\$2.28	\$3.69	\$1.90
2-wire voice unbundled incoming only port with Caller ID	UEPB1	\$2.20	\$2.00	\$1.79	\$2.61	\$2.55	\$2.12	\$2.28	\$3.69	\$1.90
2-wire voice unbundled LA Bus Area Calling Port with Caller ID (BUC)	UEPAA	NA	NA	NA	NA	\$2.55	NA	NA	NA	NA
2-wire voice unbundled SC Bus Area Calling Port with Caller ID (LMB)	UEPAB	NA	NA	NA	NA	NA	NA	NA	\$3.69	NA
2-wire voice unbundled TN Bus 2-Way Area Calling Port Economy Option (TACC1)	UEPAC	NA	NA	NA	NA	NA	NA	NA	NA	\$1.90
2-wire voice unbundled TN Bus 2-Way Area Calling Port Standard Option (TACC2)	UEPAD	NA	NA	NA	NA	NA	NA	NA	NA	\$1.90
2-wire voice unbundled TN Bus 2-WAY Collierville and Memphis Local Calling Port (B2F)	UEPAE	NA	NA	NA	NA	NA	NA	NA	NA	\$1.90
2-Wire Voice Grade Loop (SL1)										
RC - 2- Wire Voice Grade Loop - Statewide	UEPLX	NA	NA	NA	NA	NA	NA	\$14.18	NA	NA
RC - 2- Wire Voice Grade Loop - Zone 1	UEPLX	\$14.35	\$13.75	\$10.80	\$14.79	\$14.05	\$14.59	NA	\$17.02	\$15.92
RC - 2- Wire Voice Grade Loop - Zone 2	UEPLX	\$23.31	\$20.13	\$12.47	\$27.68	\$24.14	\$19.33	NA	\$25.66	\$20.79
RC - 2- Wire Voice Grade Loop - Zone 3	UEPLX	\$42.24	\$44.40	\$19.83	\$47.78	\$49.30	\$27.63	NA	\$33.99	\$27.18
RC - 2- Wire Voice Grade Loop - Zone 4	UEPLX	NA	NA	NA	NA	NA	\$36.47	NA	NA	NA
Combination Rates										
RC - 2-Wire Voice Grade Loop with 2-Wire Line Port, Statewide	Note 8	NA	NA	NA	NA	NA	NA	\$16.46	NA	NA
RC - 2-Wire Voice Grade Loop with 2-Wire Line Port, Zone 1 (Note 6)	Note 8	\$16.55	\$15.75	\$12.59	\$17.40	\$16.60	\$16.71	NA	\$20.71	\$17.84
RC - 2-Wire Voice Grade Loop with 2-Wire Line Port, Zone 2 (Note 6)	Note 8	\$25.51	\$22.13	\$14.26	\$30.29	\$26.69	\$21.45	NA	\$29.35	\$22.69
RC - 2-Wire Voice Grade Loop with 2-Wire Line Port, Zone 3 (Note 6)	Note 8	\$44.44	\$46.40	\$21.62	\$50.39	\$51.85	\$29.75	NA	\$37.68	\$29.08
RC - 2-Wire Voice Grade Loop with 2-Wire Line Port, Zone 4 (Note 6)	Note 8	NA	NA	NA	NA	NA	\$38.59	NA	NA	NA
NRC - 2-Wire Voice Grade Loop/Line Port Combination - 1st, Switch as is	USAC2	\$2.80	\$1.46	\$2.01	\$10.00	\$3.80	\$5.20	\$2.77	\$1.59	\$1.03
NRC - 2-Wire Voice Grade Loop/Line Port Combination - Add'l, Switch as is	USAC2	\$0.41	\$0.93	\$0.3108	\$10.00	\$0.29	\$0.41	\$0.40	\$0.40	\$0.2886
NRC - 2-Wire Voice Grade Loop/Line Port Combination - 1st, Switch with change	USACC	\$2.80	\$1.46	\$2.01	\$10.00	\$3.80	\$5.20	\$2.77	\$1.59	\$1.03
NRC - 2-Wire Voice Grade Loop/Line Port Combination - Add'l, Switch with change	USACC	\$0.41	\$0.93	\$0.3108	\$10.00	\$0.29	\$0.41	\$0.40	\$0.40	\$0.2886
NRC - 2-Wire Voice Grade Loop/Line Port Combination - Subsequent	USAS2	\$10.00	\$10.00	\$10.00	\$10.00	\$10.00	\$10.00	\$10.00	\$10.00	\$10.00
NRC - 2-Wire Voice Grade Loop/Line Port Combination - OSS LSR Charge, Electronic, per LSR received from the CLEC by one of the OSS interactive interfaces (Note 7)	SOMEK	\$3.50	\$3.50	\$3.50	\$3.50	\$3.50	\$3.50	\$3.50	\$3.50	\$3.50
NRC - 2-Wire Voice Grade Loop/Line Port Combination - Incremental Cost - Manual Svc.Order vs. Electronic - 1st	SOMAN	\$40.71	\$19.99	\$33.67	\$19.99	\$31.92	\$43.52	\$40.18	\$43.19	\$30.89
NRC - 2-Wire Voice Grade Loop/Line Port Combination - Incremental Cost - Manual Svc.Order vs. Electronic - Add'l	SOMAN	\$9.58	\$19.99	\$7.88	\$19.99	\$7.32	\$9.99	\$9.45	\$9.91	\$7.03
NRC - 2 Wire Voice Grade Loop/Line Port Combination - Subsequent Database Update - Electronic	TBD	\$1.44	TBD	TBD	TBD	\$2.11	\$2.87	\$1.42	\$0.71	\$0.76

BELLSOUTH/LEVEL 3 RATES
NETWORK ELEMENTS
AND OTHER SERVICES

DESCRIPTION	USOC	AL	FL	GA	KY	LA	MS	NC	SC	TN
NRC- 2 Wire Voice Grade Loop/Line Port Combination - Subsequent Database Update - Manual Service Order	TBD	\$8.25	TBD	TBD	TBD	\$5.12	\$6.88	\$10.27	\$8.91	\$7.97
NRC - Incremental Manual Service Order Disconnect	TBD	\$20.00	\$20.00	\$20.00	\$20.00	\$20.00	\$20.00	\$20.00	\$20.00	\$20.00
NRCs for New (not Currently Combined) as ordered in Georgia:										
NRC - 2-Wire Voice Grade Loop with 2-Wire Line Port - New - 1st	TBD	NA	NA	\$22.14	NA	NA	NA	NA	NA	NA
NRC - 2-Wire Voice Grade Loop with 2-Wire Line Port - New - Add'l	TBD	NA	NA	\$15.25	NA	NA	NA	NA	NA	NA
NRC - 2-Wire Voice Grade Loop/Line Port Combination - Subsequent	USAS2	NA	NA	\$10.00	NA	NA	NA	NA	NA	NA
NRC - 2-Wire Voice Grade Loop with 2-Wire Line Port - New - Disconnect - 1st	TBD	NA	NA	\$8.45	NA	NA	NA	NA	NA	NA
NRC - 2-Wire Voice Grade Loop with 2-Wire Line Port - New - Disconnect - Add'l	TBD	NA	NA	\$3.91	NA	NA	NA	NA	NA	NA
NRC - 2-Wire Voice Grade Loop/Line Port Combination - OSS LSR Charge, Electronic, per LSR received from the CLEC by one of the OSS interactive interfaces (Note 7)	SOME C	NA	NA	\$3.50	NA	NA	NA	NA	NA	NA
NRC - 2-Wire Voice Grade Loop with 2-Wire Line Port - Incremental Cost Manual vs. Electronic - New - 1st	TBD	NA	NA	\$37.06	NA	NA	NA	NA	NA	NA
NRC - 2-Wire Voice Grade Loop with 2-Wire Line Port - Incremental Cost Manual vs. Electronic - New - Add'l	TBD	NA	NA	\$8.19	NA	NA	NA	NA	NA	NA
NRC- 2 Wire Voice Grade Loop/Line Port Combination - Subsequent Database Update - Electronic	TBD	NA	NA	TBD	NA	NA	NA	NA	NA	NA
NRC- 2 Wire Voice Grade Loop/Line Port Combination - Subsequent Database Update - Manual Service Order	TBD	NA	NA	TBD	NA	NA	NA	NA	NA	NA
NRC - 2-Wire Voice Grade Loop with 2-Wire Line Port - Incremental Cost Manual vs. Electronic - New - Disconnect	TBD	NA	NA	\$11.17	NA	NA	NA	NA	NA	NA
2-Wire Voice Grade Loop - Bus Only with 2-Wire DID Trunk Port										
2-Wire Line Port - DID Trunk Port, per month	UEPD1	TBD	\$9.60	\$11.35	TBD	\$13.12	\$14.63	\$12.12	TBD	\$8.78
2-Wire Voice Grade Loop (SL2)										
RC - 2- Wire Voice Grade Loop - Statewide	UECD1	NA	NA	NA	NA	NA	NA	\$11.76	NA	NA
RC - 2- Wire Voice Grade Loop - Zone 1	UECD1	\$17.95	\$18.28	\$16.84	\$17.27	\$17.65	\$18.35	NA	\$21.57	\$15.92
RC - 2- Wire Voice Grade Loop - Zone 2	UECD1	\$29.16	\$22.34	\$19.45	\$32.32	\$30.32	\$24.33	NA	\$32.53	\$20.79
RC - 2- Wire Voice Grade Loop - Zone 3	UECD1	\$52.84	\$27.97	\$30.92	\$55.78	\$61.93	\$34.77	NA	\$43.08	\$27.18
RC - 2- Wire Voice Grade Loop - Zone 4	UECD1	NA	NA	NA	NA	NA	\$45.88	NA	NA	NA
Combination Rates										
RC - 2-Wire Voice Grade Loop with 2-Wire DID Port, Statewide	Note 8	NA	NA	NA	NA	NA	NA	\$23.79	NA	NA
RC - 2-Wire Voice Grade Loop with 2-Wire DID Port, Zone 1 (Note 6)	Note 8	TBD	\$27.88	\$28.19	TBD	\$30.77	TBD	NA	TBD	\$24.70
RC - 2-Wire Voice Grade Loop with 2-Wire DID Port, Zone 2 (Note 6)	Note 8	TBD	\$31.94	\$30.80	TBD	\$43.44	TBD	NA	TBD	\$29.57
RC - 2-Wire Voice Grade Loop with 2-Wire DID Port, Zone 3 (Note 6)	Note 8	TBD	\$37.57	\$42.27	TBD	\$75.05	TBD	NA	TBD	\$35.96
RC - 2-Wire Voice Grade Loop with 2-Wire DID Port, Zone 4 (Note 6)	Note 8	NA	NA	NA	NA	NA	TBD	NA	NA	NA
NRC- 2- Wire Voice Grade Loop with 2- Wire DID Port - 1st	TBD	TBD	\$14.73	\$166.08	TBD	TBD	TBD	\$13.26	TBD	\$8.76
NRC- 2- Wire Voice Grade Loop with 2- Wire DID Port - Add'l	TBD	TBD	\$3.76	\$140.01	TBD	TBD	TBD	\$8.39	TBD	\$5.75
NRC - 2-Wire Voice Grade Loop/Line Port Combination - OSS LSR Charge, Electronic, per LSR received from the CLEC by one of the OSS interactive interfaces (Note 7)	SOME C	\$3.50	\$3.50	\$3.50	\$3.50	\$3.50	\$3.50	\$3.50	\$3.50	\$3.50
NRC- 2- Wire Voice Grade Loop with 2- Wire DID Port - Incremental Cost- Manual Service Order - 1st	TBD	TBD	TBD	\$37.88	TBD	TBD	TBD	\$53.89	TBD	\$41.43
NRC- 2- Wire Voice Grade Loop with 2- Wire DID Port - Incremental Cost- Manual Service Order - Add'l	TBD	TBD	TBD	\$16.84	TBD	TBD	TBD	\$11.34	TBD	\$9.80
2-Wire ISDN Digital Grade Loop with 2-wire ISDN Digital Port										
2-wire ISDN Digital Port per month	UEPPB	\$16.42	\$13.00	\$13.47	\$12.33	\$23.33	\$51.91	\$24.37	\$33.74	\$18.21
2-Wire ISDN Digital Grade Loop										
RC - 2-Wire ISDN Digital Grade Loop - Statewide	USL2X	NA	NA	NA	NA	NA	NA	\$19.08	NA	NA
RC - 2-Wire ISDN Digital Grade Loop - Zone 1	USL2X	\$23.23	\$32.34	\$21.89	\$23.66	\$21.15	\$21.86	NA	\$26.68	\$15.92
RC - 2-Wire ISDN Digital Grade Loop - Zone 2	USL2X	\$37.74	\$47.35	\$25.27	\$44.28	\$36.32	\$28.97	NA	\$40.24	\$20.79
RC - 2-Wire ISDN Digital Grade Loop - Zone 3	USL2X	\$68.38	\$104.47	\$40.17	\$76.42	\$74.19	\$41.40	NA	\$53.29	\$27.18
RC - 2-Wire ISDN Digital Grade Loop - Zone 4	USL2X	NA	NA	NA	NA	NA	\$54.64	NA	NA	NA
Combination Rates										

BELLSOUTH/LEVEL 3 RATES
NETWORK ELEMENTS
AND OTHER SERVICES

DESCRIPTION	USOC	AL	FL	GA	KY	LA	MS	NC	SC	TN
RC - 2-Wire ISDN Digital Grade Loop with 2-wire ISDN Digital Port - Statewide	Note 8	NA	NA	NA	NA	NA	NA	\$43.45	NA	NA
RC - 2-Wire ISDN Digital Grade Loop with 2-wire ISDN Digital Port - Zone 1	Note 8	\$39.65	\$45.34	\$35.36	\$35.99	\$44.48	\$73.77	NA	\$60.42	\$34.13
RC - 2-Wire ISDN Digital Grade Loop with 2-wire ISDN Digital Port - Zone 2	Note 8	\$54.16	\$60.35	\$38.74	\$56.61	\$59.65	\$80.78	NA	\$73.98	\$39.00
RC - 2-Wire ISDN Digital Grade Loop with 2-wire ISDN Digital Port - Zone 3	Note 8	\$84.80	\$117.47	\$53.64	\$88.75	\$97.52	\$93.31	NA	\$87.03	\$45.39
RC - 2-Wire ISDN Digital Grade Loop with 2-wire ISDN Digital Port - Zone 4	Note 8	NA	NA	NA	NA	NA	\$106.55	NA	NA	NA
NRC - 2-Wire ISDN Digital Grade Loop/2-wire ISDN Digital Port - 1st conversion	USACB	TBD	\$3.02	TBD	TBD	TBD	TBD	\$174.35	TBD	\$117.23
NRC - 2-Wire ISDN Digital Grade Loop/2-wire ISDN Digital Port - Add'l conversion	USACB	TBD	\$2.49	TBD	TBD	TBD	TBD	\$174.35	TBD	\$117.23
NRC - 2-Wire ISDN Digital Grade Loop/2-wire ISDN Digital Port - Non Feature Subsequent Activity	USASB	TBD	TBD	TBD	TBD	TBD	TBD	\$286.15	TBD	\$212.88
NRC - 2-Wire Voice Grade Loop/Line Port Combination - OSS LSR Charge, Electronic, per LSR received from the CLEC by one of the OSS interactive interfaces (Note 7)	SOME C	\$3.50	\$3.50	\$3.50	\$3.50	\$3.50	\$3.50	\$3.50	\$3.50	\$3.50
4 - Wire DS1 Digital Loop with 4 - Wire ISDN DS1 Digital Trunk Port										
4 - Wire ISDN DS1 Digital Trunk Port	UEPPP	\$186.02	\$125.00	\$163.16	\$275.48	\$194.72	\$213.21	\$179.01	\$214.79	\$78.40
4 - Wire DS1 Digital Loop										
RC - 4 - Wire DS1 Digital Loop - Statewide	USL4P	NA	NA	NA	NA	NA	NA	\$62.71	NA	NA
RC - 4 - Wire DS1 Digital Loop - Zone 1	USL4P	\$51.74	\$64.69	\$55.53	\$50.26	\$56.32	\$50.99	NA	\$59.61	\$57.73
RC - 4 - Wire DS1 Digital Loop - Zone 2	USL4P	\$84.05	\$94.71	\$64.13	\$94.06	\$96.73	\$67.58	NA	\$89.90	\$75.40
RC - 4 - Wire DS1 Digital Loop - Zone 3	USL4P	\$152.29	\$208.93	\$101.93	\$162.34	\$197.57	\$96.58	NA	\$119.06	\$98.59
RC - 4 - Wire DS1 Digital Loop - Zone 4	USL4P	NA	NA	NA	NA	NA	\$127.47	NA	NA	NA
Combination Rates										
RC - 4 - Wire DS1 Digital Loop with 4-wire ISDN DS1 Digital Port - Statewide	Note 8	NA	NA	NA	NA	NA	NA	\$241.72	NA	NA
RC - 4 - Wire DS1 Digital Loop with 4-wire ISDN DS1 Digital Port - Zone 1	Note 8	\$237.76	\$189.69	\$218.69	\$325.74	\$251.04	\$264.20	NA	\$274.40	\$136.13
RC - 4 - Wire DS1 Digital Loop with 4-wire ISDN DS1 Digital Port - Zone 2	Note 8	\$270.07	\$219.71	\$227.29	\$369.54	\$291.45	\$280.79	NA	\$304.69	\$153.80
RC - 4 - Wire DS1 Digital Loop with 4-wire ISDN DS1 Digital Port - Zone 3	Note 8	\$338.31	\$333.93	\$265.09	\$437.82	\$392.29	\$309.79	NA	\$333.85	\$176.99
RC - 4 - Wire DS1 Digital Loop with 4-wire ISDN DS1 Digital Port - Zone 4	Note 8	NA	NA	NA	NA	NA	\$340.68	NA	NA	NA
NRC - 4 - Wire DS1 Digital Loop with 4-wire ISDN DS1 Digital Port Combination - 1st conversion	USACP	TBD	\$2.00	TBD	TBD	TBD	TBD	\$481.51	TBD	\$328.53
NRC - 4 - Wire DS1 Digital Loop with 4-wire ISDN DS1 Digital Port Combination - Add'l conversion	USACP	TBD	\$1.22	TBD	TBD	TBD	TBD	\$481.51	TBD	\$328.53
NRC - 4 - Wire DS1 Digital Loop with 4 - Wire ISDN DS1 Digital Trunk Port - Subsequent Channel Activation - Per Channel	USASP	TBD	\$29.28	TBD	TBD	TBD	TBD	\$36.92	TBD	\$28.39
NRC - 4 - Wire DS1 Digital Loop with 4-wire ISDN DS1 Digital Port Combination - Subsequent Inward/2-way Telephone Numbers	PR7TG	TBD	\$0.99	TBD	TBD	TBD	TBD	\$1.17	TBD	\$0.9353
NRC - 4 - Wire DS1 Digital Loop with 4-wire ISDN DS1 Digital Port Combination - Subsequent Outward Telephone numbers	PR7TP	TBD	\$23.20	TBD	TBD	TBD	TBD	\$28.17	TBD	\$22.36
NRC - 4 - Wire DS1 Digital Loop with 4-wire ISDN DS1 Digital Port Combination - Subsequent Inward Telephone Numbers	PR7ZT	TBD	\$46.41	TBD	TBD	TBD	TBD	\$56.33	TBD	\$44.71
NRC - 4 - Wire DS1 Digital Loop with 4-wire ISDN DS1 Digital Port Combination - Subsequent Service Order Per Order	USASP	TBD	TBD	TBD	TBD	TBD	TBD	\$255.25	TBD	\$189.76
NRC - 2 - Wire Voice Grade Loop/Line Port Combination - OSS LSR Charge, Electronic, per LSR received from the CLEC by one of the OSS interactive interfaces (Note 7)	SOME C	\$3.50	\$3.50	\$3.50	\$3.50	\$3.50	\$3.50	\$3.50	\$3.50	\$3.50
4 - Wire DS1 Digital Loop with 4 - Wire DID Trunk Port										
4 - Wire DID Trunk Port	TBD	TBD	\$63.85	\$120.80	TBD	\$149.27	\$146.46	\$123.52	TBD	\$35.55
4 - Wire DS1 Digital Loop										
4 - Wire DS1 Digital Loop - Statewide	TBD	NA	NA	NA	NA	NA	NA	\$62.71	NA	NA
4 - Wire DS1 Digital Loop - Zone 1	TBD	\$51.74	\$64.69	\$55.53	\$50.26	\$56.32	\$50.99	NA	\$59.61	\$57.73
4 - Wire DS1 Digital Loop - Zone 2	TBD	\$84.05	\$94.71	\$64.13	\$94.06	\$96.73	\$67.58	NA	\$89.90	\$75.40
4 - Wire DS1 Digital Loop - Zone 3	TBD	\$152.29	\$208.93	\$101.93	\$162.34	\$197.57	\$96.58	NA	\$119.06	\$98.59
4 - Wire DS1 Digital Loop - Zone 4	TBD	NA	NA	NA	NA	NA	\$127.47	NA	NA	NA
Combination Rates										
4 - Wire DS1 Digital Loop with 4 - Wire DID Trunk Port - Statewide	Note 8	NA	NA	NA	NA	NA	NA	\$186.23	NA	NA

BELLSOUTH/LEVEL 3 RATES
NETWORK ELEMENTS
AND OTHER SERVICES

DESCRIPTION	USOC	AL	FL	GA	KY	LA	MS	NC	SC	TN
4 - Wire DS1 Digital Loop with 4 - Wire DID Trunk Port - Zone 1	Note 8	TBD	\$128.54	\$176.33	TBD	\$205.59	\$197.45	NA	TBD	\$93.28
4 - Wire DS1 Digital Loop with 4 - Wire DID Trunk Port - Zone 2	Note 8	TBD	\$158.56	\$184.93	TBD	\$246.00	\$214.04	NA	TBD	\$110.95
4 - Wire DS1 Digital Loop with 4 - Wire DID Trunk Port - Zone 3	Note 8	TBD	\$272.78	\$222.73	TBD	\$346.84	\$243.04	NA	TBD	\$134.14
4 - Wire DS1 Digital Loop with 4 - Wire DID Trunk Port - Zone 4	Note 8	NA	NA	NA	NA	NA	\$273.93	NA	NA	NA
NRC -4 - Wire DS1 Digital Loop with 4 - Wire DID Trunk Port - 1st	TBD	TBD	TBD	\$519.42	TBD	TBD	TBD	\$490.38	TBD	\$312.91
NRC -4 - Wire DS1 Digital Loop with 4 - Wire DID Trunk Port - Addl	TBD	TBD	TBD	\$320.64	TBD	TBD	TBD	\$490.38	TBD	\$312.91
NRC -4 - Wire DS1 Digital Loop with 4 - Wire DID Trunk Port - Subsequent Channel Activation - Per Channel	TBD	TBD	TBD	TBD	TBD	TBD	TBD	\$146.91	TBD	\$108.67
NRC -4 - Wire DS1 Digital Loop with 4 - Wire ISDN DS1 Digital Trunk Port - Subsequent Telephone Numbers	TBD	TBD	TBD	TBD	TBD	TBD	TBD	\$120.96	TBD	\$88.68
NRC -4 - Wire DS1 Digital Loop with 4 - Wire ISDN DS1 Digital Trunk Port - Subsequent Signaling Changes	TBD	TBD	TBD	TBD	TBD	TBD	TBD	\$29.65	TBD	\$22.92
NRC -4 - Wire DS1 Digital Loop with 4 - Wire ISDN DS1 Digital Trunk Port - Subsequent Service Order Per Order	TBD	TBD	TBD	TBD	TBD	TBD	TBD	\$127.63	TBD	\$94.88
NRC -4 - Wire DS1 Digital Loop with 4 - Wire DID Trunk Port Combination - OSS LSR Charge, Electronic, per LSR received from the CLEC by one of the OSS interactive interfaces (Note 7)	SOME C	\$3.50	\$3.50	\$3.50	\$3.50	\$3.50	\$3.50	\$3.50	\$3.50	\$3.50
NRC -4 - Wire DS1 Digital Loop with 4 - Wire DID Trunk Port - Incremental Cost- Manual Service Order - 1st	TBD	TBD	TBD	\$37.88	TBD	TBD	TBD	TBD	TBD	TBD
NRC -4 - Wire DS1 Digital Loop with 4 - Wire DID Trunk Port - Incremental Cost- Manual Service Order - Add'l	TBD	TBD	TBD	\$16.84	TBD	TBD	TBD	TBD	TBD	TBD
2-Wire Voice Grade Loop with 2-Wire Line Port PBX										
2-Wire Analog Line Port (PBX), per month										
2 WIRE VOICE UNBUNDLED COMBINATION 2-WAY PBX TRUNK - Residence	UEPRD	\$2.20	\$2.00	\$1.79	\$2.61	\$2.55	\$2.12	\$2.28	\$3.69	\$1.90
LINE SIDE UNBUNDLED COMBINATION 2-WAY PBX TRUNK - BUSINESS	UEPPC	\$2.20	\$2.00	\$1.79	\$2.61	\$2.55	\$2.12	\$2.28	\$3.69	\$1.90
LINE SIDE UNBUNDLED OUTWARD PBX TRUNK - BUSINESS	UEPPO	\$2.20	\$2.00	\$1.79	\$2.61	\$2.55	\$2.12	\$2.28	\$3.69	\$1.90
LINE SIDE UNBUNDLED INCOMING PBX TRUNK - BUSINESS	UEPP1	\$2.20	\$2.00	\$1.79	\$2.61	\$2.55	\$2.12	\$2.28	\$3.69	\$1.90
2-WIRE VOICE UNBUNDLED 2-WAY COMBINATION PBX ALABAMA CALLING PORT	UEPA2	\$2.20	NA	NA	NA	NA	NA	NA	NA	NA
2-WIRE VOICE UNBUNDLED 2-WAY COMBINATION PBX LOUISIANA CALLING PORT	UEPL2	NA	NA	NA	NA	\$2.55	NA	NA	NA	NA
2-WIRE VOICE UNBUNDLED PBX LD TERMINAL PORTS	UEPLD	\$2.20	\$2.00	\$1.79	\$2.61	\$2.55	\$2.12	\$2.28	\$3.69	\$1.90
2-WIRE VOICE UNBUNDLED 2-WAY COMBINATION PBX TENNESSEE CALLING PORT	UEPT2	NA	NA	NA	NA	NA	NA	NA	NA	\$1.90
2-WIRE VOICE UNBUNDLED 1-WAY OUTGOING PBX TENNESSEE CALLING PORT	UEPTO	NA	NA	NA	NA	NA	NA	NA	NA	\$1.90
2-WIRE VOICE UNBUNDLED 2-WAY COMBINATION PBX USAGE PORT	UEPXA	\$2.20	\$2.00	\$1.79	\$2.61	\$2.55	\$2.12	\$2.28	\$3.69	\$1.90
2-WIRE VOICE UNBUNDLED PBX TOLL TERMINAL HOTEL PORTS	UEPXB	\$2.20	\$2.00	\$1.79	\$2.61	\$2.55	\$2.12	\$2.28	\$3.69	\$1.90
2-WIRE VOICE UNBUNDLED PBX LD DDD TERMINALS PORT	UEPXC	\$2.20	\$2.00	\$1.79	\$2.61	\$2.55	\$2.12	\$2.28	\$3.69	\$1.90
2-WIRE VOICE UNBUNDLED PBX LD TERMINAL SWITCHBOARD PORT	UEPXD	\$2.20	\$2.00	\$1.79	\$2.61	\$2.55	\$2.12	\$2.28	\$3.69	\$1.90
2-WIRE VOICE UNBUNDLED PBX LD TERMINAL SWITCHBOARD IDD CAPABLE PORT	UEPXE	\$2.20	\$2.00	\$1.79	\$2.61	\$2.55	\$2.12	\$2.28	\$3.69	\$1.90
2-WIRE VOICE UNBUNDLED 2-WAY PBX KENTUCKY ROOM AREA CALLING PORT WITHOUT LUD	UEPXF	NA	NA	NA	\$2.61	NA	NA	NA	NA	NA
2-WIRE VOICE UNBUNDLED PBX KENTUCKY LUD AREA CALLING PORT	UEPXG	NA	NA	NA	\$2.61	NA	NA	NA	NA	NA
2-WIRE VOICE UNBUNDLED PBX KENTUCKY PREMIUM CALLING PORT	UEPXH	NA	NA	NA	\$2.61	NA	NA	NA	NA	NA
2-WIRE VOICE UNBUNDLED 2-WAY KENTUCKY AREA CALLING PORT WITHOUT LUD	UEPXJ	NA	NA	NA	\$2.61	NA	NA	NA	NA	NA
2-WIRE VOICE UNBUNDLED 2-WAY PBX LOUISIANA LOCAL OPTIONAL CALLING PORT	UEPXK	NA	NA	NA	NA	\$2.55	NA	NA	NA	NA
2-WIRE VOICE UNBUNDLED 2-WAY PBX HOTEL/HOSPITAL ECONOMY ADMINISTRATIVE CALLING PORT	UEPXL	\$2.20	\$2.00	\$1.79	\$2.61	\$2.55	\$2.12	\$2.28	\$3.69	\$1.90
2-WIRE VOICE UNBUNDLED 2-WAY PBX HOTEL/HOSPITAL ECONOMY ROOM CALLING PORT	UEPXM	\$2.20	\$2.00	\$1.79	\$2.61	\$2.55	\$2.12	\$2.28	\$3.69	\$1.90
2-WIRE VOICE UNBUNDLED 1-WAY OUTGOING PBX HOTEL/HOSPITAL ECONOMY ADMINISTRATIVE CALLING PORT TENNESSEE CALLING PORT	UEPXN	NA	NA	NA	NA	NA	NA	NA	NA	\$1.90

BELLSOUTH/LEVEL 3 RATES
NETWORK ELEMENTS
AND OTHER SERVICES

DESCRIPTION	USOC	AL	FL	GA	KY	LA	MS	NC	SC	TN
2-WIRE VOICE UNBUNDLED 1-WAY OUTGOING PBX HOTEL/HOSPITAL DISCOUNT ROOM CALLING PORT	UEPXO	\$2.20	\$2.00	\$1.79	\$2.61	\$2.55	\$2.12	\$2.28	\$3.69	\$1.90
2-WIRE VOICE UNBUNDLED 1-WAY OUTGOING PBX LOUISIANA LOCAL DISCOUNT CALLING PORT	UEPXP	NA	NA	NA	NA	\$2.55	NA	NA	NA	NA
2-WIRE VOICE UNBUNDLED 2-WAY PBX MISSISSIPPI LOCAL ECONOMY CALLING PORT	UEPXQ	NA	NA	NA	NA	NA	\$2.12	NA	NA	NA
2-WIRE VOICE UNBUNDLED 2-WAY PBX MISSISSIPPI LOCAL OPTIONAL CALLING PORT	UEPXR	NA	NA	NA	NA	NA	\$2.12	NA	NA	NA
2-WIRE VOICE UNBUNDLED 1-WAY OUTGOING PBXMEASURED PORT	UEPXS	\$2.20	\$2.00	\$1.79	\$2.61	\$2.55	\$2.12	\$2.28	\$3.69	\$1.90
2-WIRE VOICE UNBUNDLED 2-WAY PBX SOUTH CAROLINA AREA PLUS CALLING PORT	UEPXT	NA	NA	NA	NA	NA	NA	NA	\$3.69	NA
2-WIRE VOICE UNBUNDLED PBX COLLIERVILLE & MEMPHIS CALLING PORT	UEPXU	NA	NA	NA	NA	NA	NA	NA	NA	\$1.90
2-WIRE VOICE UNBUNDLED 2-WAY PBX TENNESSEE REGIONSERV CALLING PORT	UEPXV	NA	NA	NA	NA	NA	NA	NA	NA	\$1.90
LOCAL NUMBER PORTABILITY (REQUIRES ONE PER PORT)	LNPCP									
2-Wire Voice Grade Loop (SL1)										
RC - 2- Wire Voice Grade Loop - Statewide	UEPLX	NA	NA	NA	NA	NA	NA	\$14.18	NA	NA
RC - 2- Wire Voice Grade Loop - Zone 1	UEPLX	\$14.35	\$13.75	\$10.80	\$14.79	\$14.05	\$14.59	NA	\$17.02	\$15.92
RC - 2- Wire Voice Grade Loop - Zone 2	UEPLX	\$23.31	\$20.13	\$12.47	\$27.68	\$24.14	\$19.33	NA	\$25.66	\$20.79
RC - 2- Wire Voice Grade Loop - Zone 3	UEPLX	\$42.24	\$44.40	\$19.83	\$47.78	\$49.30	\$27.63	NA	\$33.99	\$27.18
RC - 2- Wire Voice Grade Loop - Zone 4	UEPLX	NA	NA	NA	NA	NA	\$36.47	NA	NA	NA
Combination Rates										
RC - 2-Wire Voice Grade Loop with 2-Wire Line Port, Statewide	Note 8	NA	NA	NA	NA	NA	NA	\$16.46	NA	NA
RC - 2-Wire Voice Grade Loop with 2-Wire Line Port, Zone 1 (Note 6)	Note 8	\$16.55	\$15.75	\$12.59	#VALUE!	\$16.60	\$16.71	NA	\$20.71	\$17.84
RC - 2-Wire Voice Grade Loop with 2-Wire Line Port, Zone 2 (Note 6)	Note 8	\$25.51	\$22.13	\$14.26	#VALUE!	\$26.69	\$21.45	NA	\$29.35	\$22.69
RC - 2-Wire Voice Grade Loop with 2-Wire Line Port, Zone 3 (Note 6)	Note 8	\$44.44	\$46.40	\$21.62	#VALUE!	\$51.85	\$29.75	NA	\$37.68	\$29.08
RC - 2-Wire Voice Grade Loop with 2-Wire Line Port, Zone 4 (Note 6)	Note 8	NA	NA	NA	NA	NA	\$38.59	NA	NA	NA
NRC - 2-Wire Voice Grade Loop/Line Port Combination - 1st, Switch as is	USAC2	\$2.80	\$1.46	\$2.01	\$10.00	\$3.80	\$5.20	\$2.77	\$1.59	\$1.03
NRC - 2-Wire Voice Grade Loop/Line Port Combination - Add'l, Switch as is	USAC2	\$0.41	\$0.93	\$0.3108	\$10.00	\$0.29	\$0.41	\$0.40	\$0.40	\$0.2886
NRC - 2-Wire Voice Grade Loop/Line Port Combination - 1st, Switch with change	USACC	\$2.80	\$1.46	\$2.01	\$10.00	\$3.80	\$5.20	\$2.77	\$1.59	\$1.03
NRC - 2-Wire Voice Grade Loop/Line Port Combination - Add'l, Switch with change	USACC	\$0.41	\$0.93	\$0.3108	\$10.00	\$0.29	\$0.41	\$0.40	\$0.40	\$0.2886
NRC - 2-Wire Voice Grade Loop/Line Port Combination - Subsequent	USAS2	\$10.00	\$10.00	\$10.00	\$10.00	\$10.00	\$10.00	\$10.00	\$10.00	\$10.00
NRC - 2-Wire Voice Grade Loop/Line Port Combination - OSS LSR Charge, Electronic, per LSR received from the CLEC by one of the OSS interactive interfaces (Note 7)	SOMEK	\$3.50	\$3.50	\$3.50	\$3.50	\$3.50	\$3.50	\$3.50	\$3.50	\$3.50
NRC - 2-Wire Voice Grade Loop/Line Port Combination - Incremental Cost - Manual Svc.Order vs. Electronic - 1st	SOMAN	\$40.71	\$19.99	\$33.67	\$19.99	\$31.92	\$43.52	\$40.18	\$43.19	\$30.89
NRC - 2-Wire Voice Grade Loop/Line Port Combination - Incremental Cost - Manual Svc.Order vs. Electronic - Add'l	SOMAN	\$9.58	\$19.99	\$7.88	\$19.99	\$7.32	\$0.99	\$9.45	\$9.91	\$7.03
NRC - 2 Wire Voice Grade Loop/Line Port Combination - Subsequent Database Update - Electronic	TBD	\$1.44	TBD	TBD	TBD	\$2.11	\$2.87	\$1.42	\$0.71	\$0.76
NRC - 2 Wire Voice Grade Loop/Line Port Combination - Subsequent Database Update - Manual Service Order	TBD	\$8.25	TBD	TBD	TBD	\$5.12	\$6.88	\$10.27	\$8.91	\$7.97
NRC - Incremental Manual Service Order Disconnect	TBD	\$20.00	\$20.00	\$20.00	\$20.00	\$20.00	\$20.00	\$20.00	\$20.00	\$20.00
NRCs for New (not Currently Combined) as ordered in Georgia:										
NRC - 2-Wire Voice Grade Loop with 2-Wire Line Port - New - 1st	TBD	NA	NA	\$22.14	NA	NA	NA	NA	NA	NA
NRC - 2-Wire Voice Grade Loop with 2-Wire Line Port - New - Add'l	TBD	NA	NA	\$15.25	NA	NA	NA	NA	NA	NA
NRC - 2-Wire Voice Grade Loop/Line Port Combination - Subsequent	USAS2	NA	NA	\$10.00	NA	NA	NA	NA	NA	NA
NRC - 2-Wire Voice Grade Loop with 2-Wire Line Port - New - Disconnect - 1st	TBD	NA	NA	\$8.45	NA	NA	NA	NA	NA	NA
NRC - 2-Wire Voice Grade Loop with 2-Wire Line Port - New - Disconnect - Add'l	TBD	NA	NA	\$3.91	NA	NA	NA	NA	NA	NA

BELLSOUTH/LEVEL 3 RATES
NETWORK ELEMENTS
AND OTHER SERVICES

DESCRIPTION		USOC	AL	FL	GA	KY	LA	MS	NC	SC	TN
	NRC - 2-Wire Voice Grade Loop/Line Port Combination - OSS LSR Charge, Electronic, per LSR received from the CLEC by one of the OSS interactive interfaces (Note 7)	SOME C	NA	NA	\$3.50	NA	NA	NA	NA	NA	NA
	NRC - 2-Wire Voice Grade Loop with 2-Wire Line Port - Incremental Cost Manual vs. Electronic - New - 1st	TBD	NA	NA	\$37.06	NA	NA	NA	NA	NA	NA
	NRC - 2-Wire Voice Grade Loop with 2-Wire Line Port - Incremental Cost Manual vs. Electronic - New - Add'l	TBD	NA	NA	\$8.19	NA	NA	NA	NA	NA	NA
	NRC- 2 Wire Voice Grade Loop/Line Port Combination - Subsequent Database Update - Electronic	TBD	NA	NA	TBD	NA	NA	NA	NA	NA	NA
	NRC- 2 Wire Voice Grade Loop/Line Port Combination - Subsequent Database Update - Manual Service Order	TBD	NA	NA	TBD	NA	NA	NA	NA	NA	NA
	NRC - 2-Wire Voice Grade Loop with 2-Wire Line Port - Incremental Cost Manual vs. Electronic - New - Disconnect	TBD	NA	NA	\$11.17	NA	NA	NA	NA	NA	NA
	All Other Loop/Port Combinations	TBD	TBD	TBD	Note 2	TBD	TBD	TBD	TBD	TBD	TBD
	LOCAL NUMBER PORTABILITY (REQUIRES ONE PER PORT)	LNPCX									
NOTES:											
1	Market Rates will apply in those areas where BellSouth is not required to provide circuit switching pursuant to FCC rules.										
2	In Georgia, rates will apply for Currently Combined as well as not Currently Combined loop/port combinations unless otherwise identified.										
3	In the absence of ordered rates by a State Commission, the recurring rates for Currently Combined combinations of loop/port network elements will be the sum of the recurring rates for the UNEs which make up the combinations, and the nonrecurring rates shall be as set forth in this section.										
4	Usage and Common Transport rates associated with the stand-alone UNE port elements will apply to all combinations of loop/port network elements.										
5	Deleted										
6	Effective May 1, 2000 statewide rates will be replaced by Deaveraged Loop Rates by Zone where available. Until approximately December 31, 2000 or until such time that BellSouth billing systems have been developed to handle the new zone rate structure, BellSouth will bill at the Zone 1 Deaveraged Loop rate level only. After December 31, 2000 or such time that the billing systems have been developed to handle the new zone rate structure, BellSouth will begin billing pursuant to CLEC-1's interconnection agreement.										
7	In the absence of ordered OSS rates by a state commission, BellSouth will offer regionwide rates										
8	There is not a unique combination USOC. CLEC should submit the loop and port USOCs.										

BELLSOUTH/LEVEL 3 RATES
NETWORK ELEMENTS
AND OTHER SERVICES

ENHANCED EXTENDED LINKS (EELs)		USOC	AL	FL	GA	KY	LA	MS	NC	SC	TN
New EEL rates are the sum of the individual UNE network elements (interoffice transport and loop [channelization if applicable].											
DS1 Interoffice Channel and 2-wire VG Local Loop EEL:											
2-wire analog voice grade loop SL2 and DS1 ded interoffice transport with channelization											
Zone 1	TBD	\$196.90	TBD	\$99.22	NA	\$208.13	\$229.90	NA	\$264.80	NA	
Zone 2	TBD	\$208.11	TBD	\$101.60	NA	\$220.80	\$235.88	NA	\$275.76	NA	
Zone 3	TBD	\$231.79	TBD	\$112.08	NA	\$252.41	\$246.32	NA	\$286.31	NA	
Zone 4	TBD	NA	NA	NA	NA	NA	\$257.43	NA	NA	NA	
Recurring Charges											
2-wire VG Loop per month, statewide	UEAL2	NA	NA	NA	NA	NA	NA	\$15.88	NA	\$26.02	
2-wire VG Loop per mile, statewide	1L5ND	NA	\$0.00	\$0.00	NA	\$0.00	NA	\$0.00	NA	\$0.00	
2-wire VG Loop per month, Zone 1 (Note 1)	TBD	\$15.24	\$13.75	\$15.40	\$14.79	\$17.65	\$18.35	NA	\$21.57	NA	
2-wire VG Loop per month, Zone 2 (Note 1)	TBD	\$24.75	\$20.13	\$17.78	\$27.68	\$30.32	\$24.33	NA	\$32.53	NA	
2-wire VG Loop per month, Zone 3 (Note 1)	TBD	\$44.85	\$44.40	\$28.26	\$47.78	\$61.93	\$34.77	NA	\$43.08	NA	
2-wire VG Loop per month, Zone 4 (Note 1)	TBD	NA	NA	NA	NA	NA	\$45.88	NA	NA	NA	
Interoffice Channel - Dedicated - DS1 - per mile per month	1L5XX	NA	\$0.2035	\$0.31	NA	\$0.78	NA	\$0.78	NA	\$0.35	
Interoffice Channel - Dedicated - DS1 - Facility Termination per month	U1TF1	NA	\$93.31	\$63.39	NA	\$93.40	NA	\$93.40	NA	\$75.83	
DS1 Channelized System per month	MQ1	NA	\$154.74	\$126.22	NA	\$126.66	NA	\$126.66	NA	\$165.21	
Per additional circuit in same DS1, Recurring - Zone 1	TBD	\$19.21	NA	\$17.60	NA	\$19.07	\$18.35	NA	\$23.33	NA	
Per additional circuit in same DS1, Recurring - Zone 2	TBD	\$30.42	NA	\$19.98	NA	\$31.74	\$24.33	NA	\$34.29	NA	
Per additional circuit in same DS1, Recurring - Zone 3	TBD	\$54.10	NA	\$30.46	NA	\$63.35	\$34.77	NA	\$44.84	NA	
Per additional circuit in same DS1, Recurring - Zone 4	TBD	NA	NA	NA	NA	NA	\$45.88	NA	NA	NA	
VG (COCI) interface card per month	1D1DD	NA	\$2.22	\$2.20	NA	\$1.06	NA	\$1.06	NA	\$1.25	
Non-Recurring Charges - New EEL (Note 2)(Note 3)											
NRC- DS1 interoffice Facility Termination - 1st	U1TF1	NA	\$370.81	\$162.03	NA	\$160.49	NA	\$217.17	NA	\$165.53	
NRC-DS1 interoffice Facility Termination - Add'l	U1TF1	NA	\$247.73	\$107.76	NA	\$123.03	NA	\$163.75	NA	\$124.84	
NRC-2-wire VG Local Loop - 1st	UEAL2	NA	\$271.29	\$137.81	NA	\$128.42	NA	NA	NA	\$192.97	
NRC-2-wire VG Local Loop - Add'l	UEAL2	NA	\$104.90	\$91.65	NA	\$93.60	NA	NA	NA	\$140.72	
NRC-DS1 Channelization System -1st	MQ1	NA	\$127.67	\$131.09	NA	\$213.21	NA	\$184.35	NA	\$222.87	
NRC-DS1 Channelization System - Add'l	MQ1	NA	\$29.75	\$87.18	NA	\$133.31	NA	\$114.94	NA	\$135.80	
NRC-VG(COCI)interface card -1st	1D1VG	NA	\$12.26	\$12.15	NA	\$11.18	NA	\$12.39	NA	\$12.61	
NRC-VG(COCI)interface card - Add'l	1D1VG	NA	\$8.84	\$8.76	NA	\$8.06	NA	\$8.93	NA	\$9.03	
NRC- 2-wire VG Local Loop and Channelized DS1 Interoffice Combination - Electronic Svc Order, per LSR	SOMEK	NA	\$3.20	\$3.50	NA	\$3.50	NA	\$3.50	NA	\$3.50	
NRC- 2-wire VG Local Loop and Channelized DS1 Interoffice Combination - Manual Svc Order, per LSR	SOMAN	NA	\$25.60	NA	NA	NA	NA	NA	NA	\$19.99	
NRC- 2-wire VG Local Loop and Channelized DS1 Interoffice Combination - Manual Svc Order - 1st	SOMAN	NA	NA	\$34.00	NA	\$59.93	NA	\$38.07	NA	NA	
NRC- 2-wire VG Local Loop and Channelized DS1 Interoffice Combination - Manual Svc Order - Add'l	SOMAN	NA	NA	\$27.79	NA	\$32.29	NA	\$38.07	NA	NA	
NRC- 2-wire VG Local Loop and Channelized DS1 Interoffice Combination - Manual Svc Order - Disconnect - 1st	SOMAN	NA	NA	\$20.10	NA	\$19.47	NA	NA	NA	NA	
NRC- 2-wire VG Local Loop and Channelized DS1 Interoffice Combination - Manual Svc Order - Disconnect - Add'l	SOMAN	NA	NA	\$11.98	NA	\$8.06	NA	NA	NA	NA	
DS1 Interoffice Channel and 4-wire VG Local Loop EEL:											
4-wire analog voice grade loop and DS1 ded interoffice transport with channelization											
Zone 1	TBD	\$204.34	NA	\$101.17	NA	\$216.32	\$235.35	NA	\$274.14	NA	
Zone 2	TBD	\$129.33	NA	\$110.71	NA	\$233.81	\$242.64	NA	\$289.11	NA	
Zone 3	TBD	\$251.00	NA	\$126.28	NA	\$277.43	\$255.37	NA	\$303.52	NA	
Zone 4	TBD	NA	NA	NA	NA	NA	\$268.93	NA	NA	NA	

BELLSOUTH/LEVEL 3 RATES
NETWORK ELEMENTS
AND OTHER SERVICES

		USOC	AL	FL	GA	KY	LA	MS	NC	SC	TN
	Recurring Charges										
	4-wire VG Loop per month, statewide	UEAL4	NA	NA	NA	NA	\$31.52	NA	\$27.20	NA	NA
	4-wire VG Loop per mile, statewide	1L5ND	NA	\$0.00	\$0.00	NA	\$0.00	NA	\$0.00	NA	\$0.00
	4-wire VG Loop, per month, Zone 1 (Note 1)	TBD	\$24.01	\$24.26	\$22.88	\$20.92	\$24.36	\$22.38	NA	\$29.47	\$15.92
	4-wire VG Loop, per month, Zone 2 (Note 1)	TBD	\$39.00	\$35.51	\$26.42	\$39.14	\$41.85	\$29.67	NA	\$44.44	\$20.79
	4-wire VG Loop, per month, Zone 3 (Note 1)	TBD	\$70.67	\$78.35	\$41.99	\$67.56	\$85.47	\$42.40	NA	\$58.85	\$27.18
	4-wire VG Loop, per month, Zone 4 (Note 1)	TBD	NA	NA	NA	NA	NA	\$55.96	NA	NA	NA
	Interoffice Channel - Dedicated - DS1 - per mile per month	1L5XX	NA	\$0.2035	\$0.31	NA	\$0.78	NA	\$0.58	NA	\$0.35
	Interoffice Channel - Dedicated - DS1 - Facility Termination per month	U1TF1	NA	\$93.31	\$63.39	NA	\$93.40	NA	\$71.29	NA	\$75.83
	DS1 Channelized System per month	MQ1	NA	\$154.74	\$18.23	NA	\$126.66	NA	\$158.01	NA	\$165.21
	Per additional circuit in same DS1, Recurring - Zone 1	TBD	26.65	NA	\$24.93	NA	\$27.26	\$22.38	NA	\$32.67	NA
	Per additional circuit in same DS1, Recurring - Zone 2	TBD	41.64	NA	\$28.37	NA	\$44.75	\$29.67	NA	\$47.64	NA
	Per additional circuit in same DS1, Recurring - Zone 3	TBD	54.1	NA	\$43.52	NA	\$88.37	\$42.40	NA	\$62.05	NA
	Per additional circuit in same DS1, Recurring - Zone 4	TBD	NA	NA	NA	NA	\$55.96	NA	NA	NA	NA
	VG (COCL) interface card per month	1D1DD	NA	\$1.46	\$2.67	NA	\$1.06	NA	\$1.28	NA	\$1.25
	Non-Recurring Charges - New EEL (Note 2) (Note 3)										
	NRC- DS1 interoffice Facility Termination - 1st	U1TF1	NA	\$370.81	\$162.03	NA	\$160.49	NA	\$534.48	NA	\$165.53
	NRC-DS1 interoffice Facility Termination - Add'l	U1TF1	NA	\$247.73	\$107.76	NA	\$123.03	NA	\$462.69	NA	\$124.84
	NRC-4-wire VG Local Loop - 1st	UEAL2	NA	\$271.29	\$290.91	NA	\$128.42	NA	\$86.50	NA	\$192.97
	NRC-4-wire VG Local Loop - Add'l	UEAL2	NA	\$104.90	\$235.93	NA	\$93.60	NA	\$27.80	NA	\$140.72
	NRC-DS1 Channelization System -1st	MQ1	NA	\$127.67	\$131.09	NA	\$213.21	NA	\$262.56	NA	\$222.87
	NRC-DS1 Channelization System - Add'l	MQ1	NA	\$29.75	\$87.18	NA	\$133.31	NA	\$163.02	NA	\$135.80
	NRC-VG(COCL)interface card -1st	1D1VG	NA	\$12.26	\$12.15	NA	\$11.18	NA	\$12.39	NA	\$12.61
	NRC-VG(COCL)interface card - Add'l	1D1VG	NA	\$8.84	\$8.78	NA	\$8.06	NA	\$8.93	NA	\$9.03
	NRC-DS1 interoffice channel and 4-wire VG Local Loop Combination - Electronic Svc Order, per LSR	SOMEK	NA	\$3.20	\$3.50	NA	\$3.50	NA	\$3.50	NA	\$3.50
	NRC-DS1 interoffice channel and 4-wire VG Local Loop Combination - Manual Svc Order, per LSR	SOMAN	NA	\$25.60	NA	NA	NA	NA	NA	NA	\$19.99
	NRC-DS1 interoffice channel and 4-wire VG Local Loop Combination - Manual Svc Order - 1st	SOMAN	NA	NA	NA	NA	\$59.93	NA	\$25.51	NA	NA
	NRC-DS1 interoffice channel and 4-wire VG Local Loop Combination - Manual Svc Order - Add'l	SOMAN	NA	NA	NA	NA	\$32.29	NA	\$8.37	NA	NA
	NRC-DS1 interoffice channel and 4-wire VG Local Loop Combination - Manual Svc Order - Disconnect - 1st	SOMAN	NA	NA	NA	NA	\$19.47	NA	NA	NA	NA
	NRC-DS1 interoffice channel and 4-wire VG Local Loop Combination - Manual Svc Order - Disconnect - Add'l	SOMAN	NA	NA	NA	NA	\$8.06	NA	NA	NA	NA
	DS1 Interoffice Channel and 2-wire ISDN Local Loop:	USOC	AL	FL	GA	KY	LA	MS	NC	SC	TN
	Recurring Charges										
	2-wire ISDN Loop per month, statewide	U1L2X	NA	NA	NA	NA	NA	NA	\$27.20	NA	NA
	2-wire ISDN Loop per month, Zone 1 (Note 1)	TBD	\$23.23	\$32.34	\$21.89	\$23.66	\$21.15	\$21.86	TBD	\$26.68	\$15.92
	2-wire ISDN Loop per month, Zone 2 (Note 1)	TBD	\$37.74	\$47.35	\$25.27	\$44.28	\$36.22	\$28.97	TBD	\$40.24	\$20.79
	2-wire ISDN Loop per month, Zone 3 (Note 1)	TBD	\$68.38	\$104.47	\$40.17	\$76.42	\$74.19	\$41.40	TBD	\$53.29	\$27.18
	2-wire ISDN Loop per month, Zone 4 (Note 1)	NA	NA	NA	NA	NA	NA	\$54.64	NA	NA	NA
	Interoffice Channel - Dedicated - DS1 - per mile per month	1L5XX	NA	\$0.2035	\$0.31	NA	\$0.78	NA	\$0.58	NA	\$0.35
	Interoffice Channel - Dedicated - DS1 - Facility Termination per month	U1TF1	NA	\$93.31	\$63.39	NA	\$93.40	NA	\$71.29	NA	\$75.83
	DS1 Channelized System per month	MQ1	NA	\$154.74	\$126.22	NA	\$126.66	NA	\$158.01	NA	\$165.21
	2-wire ISDN(BRITE COCL) per month	UC1CA	NA	\$3.86	\$3.41	NA	\$4.18	NA	\$3.76	NA	\$3.33
	Non-Recurring Charges - New EEL (Note 2)(Note 3)										
	NRC- DS1 interoffice Facility Termination - 1st	U1TF1	NA	\$370.81	\$162.03	NA	\$160.49	NA	\$217.17	NA	\$165.53
	NRC-DS1 interoffice Facility Termination - Add'l	U1TF1	NA	\$247.73	\$107.76	NA	\$123.03	NA	\$163.75	NA	\$124.84
	NRC- 2-wire ISDN Local Loop - 1st	U1L2X	NA	\$271.29	\$137.81	NA	\$223.27	NA	\$276.96	NA	\$58.50
	NRC- 2-wire ISDN Local Loop - Add'l	U1L2X	NA	\$104.90	\$91.65	NA	\$172.63	NA	\$234.99	NA	\$31.00
	NRC-DS1 Channelization System -1st	MQ1	NA	\$127.67	\$131.09	NA	\$213.21	NA	\$262.56	NA	\$222.87
	NRC-DS1 Channelization System - Add'l	MQ1	NA	\$29.75	\$87.18	NA	\$133.31	NA	\$163.02	NA	\$135.80
	NRC-2-wire BRITE(COCL)interface card -1st	1D1VG	NA	\$12.26	\$12.15	NA	\$12.29	NA	\$15.76	NA	\$12.61

BELLSOUTH/LEVEL 3 RATES
NETWORK ELEMENTS
AND OTHER SERVICES

		USOC	AL	FL	GA	KY	LA	MS	NC	SC	TN
	NRC-2-wire BRITE(COCL)interface card -Add'l	1D1VG	NA	\$8.84	\$8.76	NA	\$8.80	NA	\$11.28	NA	\$9.03
	NRC-DS1 interoffice channel and 2-wire ISDN Local Loop Combination - Electronic Svc Order, per LSR	SOMEK	NA	\$3.20	\$3.50	NA	\$3.50	NA	\$3.50	NA	\$3.50
	NRC-DS1 interoffice channel and 2-wire ISDN Local Loop Combination - Manual Svc Order, per LSR	SOMAN	NA	\$25.60	NA	NA	NA	NA	NA	NA	\$19.99
	NRC-DS1 interoffice channel and 2-wire ISDN Local Loop Combination - Manual Svc Order - 1st	SOMAN	NA	NA	\$34.00	NA	\$57.58	NA	\$38.07	NA	NA
	NRC-DS1 interoffice channel and 2-wire ISDN Local Loop Combination - Manual Svc Order - Add'l	SOMAN	NA	NA	\$27.79	NA	\$36.31	NA	\$38.07	NA	NA
	NRC-DS1 interoffice channel and 2-wire ISDN Local Loop Combination - Manual Svc Order - Disconnect - 1st	SOMAN	NA	NA	\$20.10	NA	\$16.12	NA	NA	NA	NA
	NRC-DS1 interoffice channel and 2-wire ISDN Local Loop Combination - Manual Svc Order - Disconnect - Add'l	SOMAN	NA	NA	\$11.98	NA	\$8.06	NA	NA	NA	NA
	DS1 Interoffice Channel and 4-wire 56 kbps Local Loop:										
	56 kbps loop and DS1 ded interoffice transport with channelization										
	Zone 1	TBD	\$207.66	NA	\$109.12	NA	\$219.46	\$238.58	NA	\$278.93	NA
	Zone 2	TBD	\$224.73	NA	\$113.21	NA	\$239.20	\$246.91	NA	\$296.34	NA
	Zone 3	TBD	\$280.78	NA	\$131.21	NA	\$288.44	\$261.48	NA	\$313.10	NA
	Zone 4	TBD	NA	NA	NA	NA	NA	\$276.99	NA	NA	NA
	Recurring Charges										
	4-wire 56kbps Loop per month, statewide	UDL56	NA	\$36.98	\$30.72	NA	\$35.58	NA	\$40.12	NA	NA
	4-wire 56kbps Loop per mile, statewide	1L5ND	NA	\$0.00	\$0.00	NA	\$0.00	NA	\$0.00	NA	\$0.00
	4-wire 56 kbps Loop, per month, Zone 1 (Note 1)	TBD	\$27.33	\$39.08	\$26.44	NA	\$27.50	\$25.61	NA	\$34.26	\$36.45
	4-wire 56 kbps Loop, per month, Zone 2 (Note 1)	TBD	\$44.40	\$57.21	\$30.53	NA	\$47.24	\$33.94	NA	\$51.67	\$45.87
	4-wire 56 kbps Loop, per month, Zone 3 (Note 1)	TBD	\$80.45	\$126.22	\$48.53	NA	\$96.48	\$48.51	NA	\$68.43	\$65.75
	4-wire 56 kbps Loop, per month, Zone 4 (Note 1)	TBD	NA	NA	NA	NA	NA	\$64.02	NA	NA	NA
	Interoffice Channel - Dedicated - DS1 - per mile per month	1L5XX	NA	\$0.2035	\$0.31	NA	\$0.78	NA	\$0.58	NA	\$0.35
	Interoffice Channel - Dedicated - DS1 - Facility Termination per month	U1TF1	NA	\$93.31	\$63.39	NA	\$93.40	NA	\$71.29	NA	\$75.83
	DS1 Channelized System per month	MQ1	NA	\$154.74	\$18.23	NA	\$126.66	NA	\$158.01	NA	\$165.21
	Per additional circuit in same DS1, Recurring - Zone 1	TBD	\$29.97	NA	\$28.42	NA	\$30.40	\$28.48	NA	\$37.46	NA
	Per additional circuit in same DS1, Recurring - Zone 2	TBD	\$47.04	NA	\$32.41	NA	\$50.14	\$36.81	NA	\$54.87	NA
	Per additional circuit in same DS1, Recurring - Zone 3	TBD	\$73.31	NA	\$49.94	NA	\$99.38	\$51.38	NA	\$71.63	NA
	Per additional circuit in same DS1, Recurring - Zone 4	TBD	NA	NA	NA	NA	NA	\$66.89	NA	NA	NA
	4-wire 56kbps card COCL per month	1D1DD	NA	\$2.22	\$1.06	NA	\$1.94	NA	\$2.03	NA	\$2.46
	Non-Recurring Charges - New EEL (Note 2) (Note 3)										
	NRC- DS1 interoffice Facility Termination - 1st	U1TF1	NA	\$370.81	\$162.03	NA	\$160.49	NA	\$217.17	NA	\$165.53
	NRC-DS1 interoffice Facility Termination - Add'l	U1TF1	NA	\$247.73	\$107.76	NA	\$123.03	NA	\$163.75	NA	\$124.84
	NRC-4-wire 56kbps Local Loop - 1st	UDL56	NA	\$271.29	\$458.86	NA	\$333.28	NA	\$642.74	NA	\$643.00
	NRC-4-wire 56kbps Local Loop - Add'l	UDL56	NA	\$104.90	\$279.18	NA	\$230.50	NA	\$421.02	NA	NA
	NRC-DS1 Channelization System -1st	MQ1	NA	\$127.67	\$131.09	NA	\$213.21	NA	\$262.56	NA	\$222.87
	NRC-DS1 Channelization System - Add'l	MQ1	NA	\$29.75	\$87.18	NA	\$133.31	NA	\$163.02	NA	\$135.80
	NRC-4-wire 56kbps(COCL)interface card -1st	1D1DD	NA	\$12.26	\$12.15	NA	\$11.18	NA	\$12.39	NA	\$12.61
	NRC-4-wire 56kbps(COCL)interface card -Add'l	1D1DD	NA	\$8.84	\$8.76	NA	\$8.06	NA	\$8.93	NA	\$9.03
	NRC-DS1 interoffice channel and 4-wire 56kbps Local Loop Combination - Electronic Svc Order, per LSR	SOMEK	NA	\$3.20	\$3.50	NA	\$3.50	NA	\$3.50	NA	\$3.50
	NRC-DS1 interoffice channel and 4-wire 56kbps Local Loop Combination - Manual Svc Order, per LSR	SOMAN	NA	\$25.60	NA	NA	NA	NA	NA	NA	\$19.99
	NRC-DS1 interoffice channel and 4-wire 56kbps Local Loop Combination - Manual Svc Order - 1st	SOMAN	NA	NA	\$34.00	NA	\$59.93	NA	\$38.07	NA	NA
	NRC-DS1 interoffice channel and 4-wire 56kbps Local Loop Combination - Manual Svc Order - Add'l	SOMAN	NA	NA	\$27.79	NA	\$32.29	NA	\$38.07	NA	NA
	NRC-DS1 interoffice channel and 4-wire 56kbps Local Loop Combination - Manual Svc Order - Disconnect - 1st	SOMAN	NA	NA	\$20.10	NA	\$19.47	NA	NA	NA	NA

BELLSOUTH/LEVEL 3 RATES
NETWORK ELEMENTS
AND OTHER SERVICES

		USOC	AL	FL	GA	KY	LA	MS	NC	SC	TN
	NRC-DS1 interoffice channel and 4-wire 56kbps Local Loop Combination - Manual Svc Order - Disconnect - Add'l	SOMAN	NA	NA	\$11.98	NA	\$8.06	NA	NA	NA	NA
	DS1 Interoffice Channel and 4-wire 64 kbps Local Loop:										
	4-wire analog voice grade loop and DS1 ded interoffice transport with channelization										
	Zone 1	TBD	\$204.34	NA	\$109.12	NA	\$219.46	\$238.58	NA	\$278.93	NA
	Zone 2	TBD	\$219.33	NA	\$113.21	NA	\$239.20	\$246.91	NA	\$296.34	NA
	Zone 3	TBD	\$251.00	NA	\$131.21	NA	\$288.44	\$261.48	NA	\$313.10	NA
	Zone 4	TBD	NA	NA	NA	NA	NA	\$276.99	NA	NA	NA
	Recurring Charges										
	4-wire 64kbps Loop per month, statewide	UDL64	NA	\$36.98	\$30.72	NA	\$35.58	NA	\$40.12	NA	\$42.23
	4-wire 64kbps Loop per mile, statewide	1L5ND	NA	\$0.00	\$0.00	NA	\$0.00	NA	\$0.00	NA	\$0.00
	4-wire 64kbps Loop per month, Zone 1 (Note 1)	TBD	\$27.33	\$39.08	\$26.44	NA	\$27.50	\$25.61	NA	\$34.26	\$36.45
	4-wire 64kbps Loop per month, Zone 2 (Note 1)	TBD	\$44.40	\$57.21	\$30.53	NA	\$47.24	\$33.94	NA	\$51.67	\$45.87
	4-wire 64kbps Loop per month, Zone 3 (Note 1)	TBD	\$80.45	\$126.22	\$48.53	NA	\$96.48	\$48.51	NA	\$68.43	\$65.75
	4-wire 64kbps Loop per month, Zone 4 (Note 1)	NA	NA	NA	NA	NA	NA	NA	NA	NA	NA
	Interoffice Channel - Dedicated - DS1 - per mile per month	1L5XX	NA	\$0.2035	\$0.31	NA	\$0.78	NA	\$0.58	NA	\$0.35
	Interoffice Channel - Dedicated - DS1 - Facility Termination per month	U1TF1	NA	\$93.31	\$63.39	NA	\$93.40	NA	\$71.29	NA	\$75.83
	DS1 Channelized System per month	MQ1	NA	\$154.74	\$18.23	NA	\$126.66	NA	\$158.01	NA	\$165.21
	Per additional circuit in same DS1, Recurring - Zone 1	TBD	\$29.97	NA	\$28.42	NA	\$30.40	\$28.48	NA	\$37.46	NA
	Per additional circuit in same DS1, Recurring - Zone 2	TBD	\$47.04	NA	\$32.41	NA	\$50.14	\$36.81	NA	\$54.87	NA
	Per additional circuit in same DS1, Recurring - Zone 3	TBD	\$73.31	NA	\$49.94	NA	\$99.38	\$51.38	NA	\$71.63	NA
	Per additional circuit in same DS1, Recurring - Zone 4	TBD	NA	NA	NA	NA	NA	\$66.89	NA	NA	NA
	4-wire 64kbps card COCI per month	1D1DD	NA	\$1.06	\$1.06	NA	\$1.94	NA	\$2.03	NA	\$2.46
	Non-Recurring Charges - New EEL (Note 2) (Note 3)										
	NRC- DS1 interoffice - 1st	U1TF1	NA	\$370.81	\$162.03	NA	\$160.49	NA	\$217.17	NA	\$165.53
	NRC- DS1 interoffice - Add'l	U1TF1	NA	\$247.73	\$107.76	NA	\$123.03	NA	\$163.75	NA	\$124.84
	NRC-4-wire 64kbps Local Loop - 1st	UDL64	NA	\$271.29	\$458.86	NA	\$333.28	NA	\$642.74	NA	\$192.97
	NRC-4-wire 64kbps Local Loop - Add'l	UDL64	NA	\$104.90	\$279.18	NA	\$230.50	NA	\$421.02	NA	\$140.72
	NRC-DS1 Channelization System -1st	MQ1	NA	\$127.67	\$131.09	NA	\$213.21	NA	\$262.56	NA	\$222.87
	NRC-DS1 Channelization System - Add'l	MQ1	NA	\$29.75	\$87.18	NA	\$133.31	NA	\$249.15	NA	\$135.80
	NRC-4-wire 64kbps(COC)interface card -1st	1D1DD	NA	\$12.26	\$12.15	NA	\$11.18	NA	\$12.39	NA	\$12.61
	NRC-4-wire 64kbps(COC)interface card -Add'l	1D1DD	NA	\$8.84	\$8.76	NA	\$8.06	NA	\$8.93	NA	\$9.03
	NRC-DS1 interoffice channel and 4-wire 64kbps Local Loop Combination - Electronic Svc Order, per LSR	SOMEK	NA	\$3.20	\$3.50	NA	\$3.50	NA	\$3.50	NA	\$3.50
	NRC-DS1 interoffice channel and 4-wire 64kbps Local Loop Combination - Manual Svc Order, per LSR	SOMAN	NA	\$25.60	NA	NA	NA	NA	NA	NA	\$19.99
	NRC-DS1 interoffice channel and 4-wire 64kbps Local Loop Combination - Manual Svc Order - 1st	SOMAN	NA	NA	\$34.00	NA	\$59.93	NA	\$38.07	NA	NA
	NRC-DS1 interoffice channel and 4-wire 64kbps Local Loop Combination - Manual Svc Order - Add'l	SOMAN	NA	NA	\$27.79	NA	\$32.29	NA	\$38.07	NA	NA
	NRC-DS1 interoffice channel and 4-wire 64kbps Local Loop Combination - Manual Svc Order - Disconnect - 1st	SOMAN	NA	NA	\$20.10	NA	\$19.47	NA	NA	NA	NA
	NRC-DS1 interoffice channel and 4-wire 64kbps Local Loop Combination - Manual Svc Order - Disconnect - Add'l	SOMAN	NA	NA	\$11.98	NA	\$8.06	NA	NA	NA	NA
	DS1 Interoffice Channel and DS1 Interoffice Local Loop:										
	DS1 Loop per month, State wide	USLXX	NA	\$96.46	\$60.88	NA	\$35.58	NA	\$151.50	NA	NA
	DS1 Loop per mile, statewide	1L5ND	NA	\$0.00	\$0.00	NA	\$0.00	NA	\$0.00	NA	\$0.00
	DS1 Loop per month, Zone 1 (Note 1)	TBD	NA	TBD	\$22.88	NA	TBD	NA	TBD	NA	TBD
	DS1 Loop per month, Zone 2 (Note 1)	TBD	NA	TBD	\$26.42	NA	TBD	NA	TBD	NA	TBD
	DS1 Loop per month, Zone 3 (Note 1)	TBD	NA	TBD	\$41.99	NA	TBD	NA	TBD	NA	TBD
	DS1 Loop per month, Zone 4 (Note 1)	NA	NA	NA	NA	NA	NA	NA	NA	NA	NA
	Interoffice Channel - Dedicated - DS1 - per mile per month	1L5XX	NA	\$0.2035	\$0.31	NA	\$0.78	NA	\$0.58	NA	NA
	Interoffice Channel - Dedicated - DS1 - Facility Termination per month	U1TF1	NA	\$93.31	\$63.39	NA	\$93.40	NA	\$71.29	NA	NA

BELLSOUTH/LEVEL 3 RATES
NETWORK ELEMENTS
AND OTHER SERVICES

		USOC	AL	FL	GA	KY	LA	MS	NC	SC	TN
Non-Recurring Charges - New EEL (Note 2) (Note 3)											
	NRC- DS1 interoffice - 1st	U1TF1	NA	\$370.81	\$258.46	NA	\$160.49	NA	\$217.17	NA	NA
	NRC- DS1 interoffice - Add'l	U1TF1	NA	\$247.73	\$109.53	NA	\$123.03	NA	\$163.75	NA	NA
	NRC-DS1 Local Loop - 1st	USLXX	NA	\$434.24	\$520.02	NA	\$502.73	NA	\$568.96	NA	NA
	NRC-DS1 Local Loop - Add'l	USLXX	NA	\$235.29	\$220.38	NA	\$293.92	NA	\$335.56	NA	NA
	NRC-DS1 interoffice channel and DS1 Local Loop Combination - Electronic Svc Order, per LSR	SOMEK	NA	\$3.20	\$3.50	NA	\$3.50	NA	\$3.50	NA	\$3.50
	NRC-DS1 interoffice channel and DS1 Local Loop Combination - Manual Svc Order, per LSR	SOMAN	NA	\$25.60	NA	NA	NA	NA	NA	NA	\$19.99
	NRC-DS1 interoffice channel and DS1 Local Loop Combination - Manual Svc Order - 1st	SOMAN	NA	NA	\$34.00	NA	\$59.93	NA	\$38.07	NA	NA
	NRC-DS1 interoffice channel and DS1 Local Loop Combination - Manual Svc Order - Add'l	SOMAN	NA	NA	\$27.79	NA	\$32.29	NA	\$38.07	NA	NA
	NRC-DS1 interoffice channel and DS1 Local Loop Combination - Manual Svc Order - Disconnect - 1st	SOMAN	NA	NA	\$20.10	NA	\$19.47	NA	NA	NA	NA
	NRC-DS1 interoffice channel and DS1 Local Loop Combination - Manual Svc Order - Disconnect - Add'l	SOMAN	NA	NA	\$11.98	NA	\$8.06	NA	NA	NA	NA
DS3 Interoffice Channel and DS3 Local Loop:											
	DS3 Loop per Facility Termination per month	UE3PX	NA	\$407.58	\$390.34	NA	\$573.23	NA	\$413.09	NA	\$607.28
	DS3 Loop per mile	1L5ND	NA	\$11.97	\$8.90	NA	\$8.77	NA	\$11.40	NA	\$23.76
	Interoffice Channel - Dedicated - DS3 - Facility Termination per month	1L5XX	NA	\$1,130	\$717.60	NA	\$1,025.00	NA	\$720.38	NA	\$840.61
	Interoffice Channel - Dedicated - DS3 - per mile per month	U1TF3	NA	\$4.25	\$0.31	NA	\$6.78	NA	\$12.98	NA	\$6.88
Non-Recurring Charges - New EEL (Note 2)(Note 3)											
	NRC- DS3 interoffice - 1st	U1TF3	NA	\$682.89	\$674.50	NA	\$589.06	NA	\$794.94	NA	\$877.70
	NRC- DS3 interoffice - Add'l	U1TF3	NA	\$288.32	\$437.35	NA	\$418.42	NA	\$579.55	NA	\$540.32
	NRC-DS3 Local Loop - 1st	UE3PX	NA	\$502.08	\$761.81	NA	\$696.86	NA	\$757.25	NA	\$829.52
	NRC-DS3 Local Loop - Add'l	UE3PX	NA	\$307.56	\$545.54	NA	\$496.00	NA	\$534.95	NA	\$512.23
	NRC-DS3 interoffice channel and DS3 Local Loop Combination - Electronic Svc Order, per LSR	SOMEK	NA	\$3.20	\$3.50	NA	\$3.50	NA	\$3.50	NA	\$3.50
	NRC-DS3 interoffice channel and DS3 Local Loop Combination - Manual Svc Order, per LSR	SOMAN	NA	\$25.60	NA	NA	NA	NA	NA	NA	\$19.99
	NRC-DS3 interoffice channel and DS3 Local Loop Combination - Manual Svc Order - 1st	SOMAN	NA	NA	\$37.55	NA	\$69.84	NA	\$56.25	NA	NA
	NRC-DS3 interoffice channel and DS3 Local Loop Combination - Manual Svc Order - Add'l	SOMAN	NA	NA	\$37.55	NA	\$69.84	NA	\$56.25	NA	NA
	NRC-DS3 interoffice channel and DS3 Local Loop Combination - Manual Svc Order - Disconnect - 1st	SOMAN	NA	NA	\$18.03	NA	\$37.71	NA	NA	NA	NA
	NRC-DS3 interoffice channel and DS3 Local Loop Combination - Manual Svc Order - Disconnect - Add'l	SOMAN	NA	NA	\$18.03	NA	\$37.71	NA	NA	NA	NA
STS-1 Interoffice Channel and STS-1 Local Loop:											
	STS-1 Loop per Facility Termination per month	UDLS1	NA	\$449.40	\$390.34	NA	\$454.28	NA	\$428.93	NA	\$400.21
	STS-1 Loop per mile	1L5ND	NA	\$11.97	\$8.90	NA	\$11.26	NA	\$11.40	NA	\$30.53
	Interoffice Channel - Dedicated - STS-1 - Facility Termination per month	U1TS1	NA	\$1,114	\$783.63	NA	\$1,000.00	NA	\$800.94	NA	\$838.65
	Interoffice Channel - Dedicated - STS-1 - per mile per month	1L5XX	NA	\$4.25	\$2.75	NA	\$6.78	NA	\$6.29	NA	\$6.88
Non-Recurring Charges - New EEL (Note 2)(Note 3)											
	NRC- STS-1 interoffice - 1st	U1TFS	NA	\$682.89	\$633.41	NA	\$589.06	NA	\$624.86	NA	\$1,012.52
	NRC- STS-1 interoffice - Add'l	U1TFS	NA	\$288.32	\$569.05	NA	\$418.42	NA	\$436.36	NA	\$655.99
	NRC-STS-1 Local Loop - 1st	U1TS1	NA	\$502.08	\$761.81	NA	\$708.46	NA	\$757.25	NA	\$829.52
	NRC-STS-1 Local Loop - Add'l	U1TS1	NA	\$307.56	\$545.54	NA	\$507.34	NA	\$534.95	NA	\$512.23
	NRC-STS-1 interoffice channel and STS-1 Local Loop Combination - Electronic Svc Order, per LSR	SOMEK	NA	\$3.20	\$3.50	NA	\$3.50	NA	\$3.50	NA	\$3.50
	NRC-STS-1 interoffice channel and STS-1 Local Loop Combination - Manual Svc Order, per LSR	SOMAN	NA	\$25.60	NA	NA	NA	NA	NA	NA	\$19.99

BELLSOUTH/LEVEL 3 RATES
NETWORK ELEMENTS
AND OTHER SERVICES

		USOC	AL	FL	GA	KY	LA	MS	NC	SC	TN
	NRC-STS-1 interoffice channel and STS-1 Local Loop Combination - Manual Svc Order - 1st	SOMAN	NA	NA	\$37.55	NA	\$69.84	NA	\$55.00	NA	NA
	NRC-STS-1 interoffice channel and STS-1 Local Loop Combination - Manual Svc Order - Add'l	SOMAN	NA	NA	\$37.55	NA	\$69.84	NA	\$55.00	NA	NA
	NRC-STS-1 interoffice channel and STS-1 Local Loop Combination - Manual Svc Order - Disconnect - 1st	SOMAN	NA	NA	\$18.03	NA	\$37.71	NA	NA	NA	NA
	NRC-STS-1 interoffice channel and STS-1 Local Loop Combination - Manual Svc Order - Disconnect - Add'l	SOMAN	NA	NA	\$18.03	NA	\$37.71	NA	NA	NA	NA
	DS3 Interoffice Channel and DS1 Local Loop:										
	DS1 Loop per month, State wide	USLXX	NA	\$96.46	\$60.88	NA	\$35.58	NA	\$151.50	NA	NA
	DS1 Loop per mile, statewide	1L5ND	NA	\$0.00	\$0.00	NA	\$0.00	NA	\$0.00	NA	\$0.00
	DS1 Loop per month, Zone 1 (Note 1)	TBD	NA	TBD	\$22.88	NA	TBD	NA	TBD	NA	TBD
	DS1 Loop per month, Zone 2 (Note 1)	TBD	NA	TBD	\$26.42	NA	TBD	NA	TBD	NA	TBD
	DS1 Loop per month, Zone 3 (Note 1)	TBD	NA	TBD	\$41.99	NA	TBD	NA	TBD	NA	TBD
	DS1 Loop per month, Zone 4 (Note 1)	NA	NA	NA	NA	NA	NA	NA	NA	NA	NA
	Interoffice Channel - Dedicated - DS3 - Facility Termination per month	1L5XX	NA	\$1,130	\$717.60	NA	\$1,025.00	NA	\$720.38	NA	\$840.61
	Interoffice Channel - Dedicated - DS3 - per mile per month	U1TF3	NA	\$4.25	\$6.46	NA	\$6.78	NA	\$12.98	NA	\$6.88
	DS3 Channelized System per month	MQ3	NA	\$222.61	\$202.91	NA	\$244.37	NA	\$236.35	NA	\$225.59
	DS3 Interface per month (DS1 COCI)	UC1D1	NA	\$14.51	\$0.67	NA	\$15.49	NA	\$16.29	NA	\$3.91
	Non-Recurring Charges - New EEL (Note 2)(Note 3)										
	NRC- DS3 interoffice - 1st	U1TF3	NA	\$682.89	\$458.74	NA	\$589.06	NA	\$794.94	NA	\$877.70
	NRC- DS3 interoffice - Add'l	U1TF3	NA	\$288.32	\$257.24	NA	\$418.42	NA	\$579.55	NA	\$540.32
	NRC-DS1 Local Loop - 1st	USLXX	NA	\$434.24	\$334.23	NA	\$502.73	NA	\$568.96	NA	NA
	NRC-DS1 Local Loop - Add'l	USLXX	NA	\$235.29	\$187.42	NA	\$293.92	NA	\$335.56	NA	NA
	NRC-DS3 Channelization System -1st	MQ3	NA	\$240.04	\$196.71	NA	\$314.72	NA	\$331.54	NA	\$326.17
	NRC-DS3 Channelization System - Add'l	MQ3	NA	\$106.82	\$110.30	NA	\$224.70	NA	\$241.81	NA	\$236.25
	NRC-DS1(COC)interface card -1st	UC1D1	NA	\$12.26	\$12.15	NA	\$11.18	NA	\$12.39	NA	\$12.61
	NRC-DS1(COC)interface card -Add'l	UC1D1	NA	\$8.84	\$8.76	NA	\$8.06	NA	\$8.93	NA	\$9.03
	NRC-DS3 interoffice channel and DS1 Local Loop Combination - Electronic Svc Order, per LSR	SOMEK	NA	\$3.20	\$3.50	NA	\$3.50	NA	\$3.50	NA	\$3.50
	NRC-DS3 interoffice channel and DS1 Local Loop Combination - Manual Svc Order, per LSR	SOMAN	NA	\$25.60	\$34.00	NA	NA	NA	NA	NA	\$19.99
	NRC-DS3 interoffice channel and DS1 Local Loop Combination - Manual Svc Order - 1st	SOMAN	NA	NA	\$27.79	NA	\$36.28	NA	\$91.26	NA	NA
	NRC-DS3 interoffice channel and DS1 Local Loop Combination - Manual Svc Order - Add'l	SOMAN	NA	NA	\$20.10	NA	\$26.20	NA	\$91.26	NA	NA
	NRC-DS3 interoffice channel and DS1 Local Loop Combination - Manual Svc Order - Disconnect - 1st	SOMAN	NA	NA	\$11.98	NA	\$19.47	NA	NA	NA	NA
	NRC-DS3 interoffice channel and DS1 Local Loop Combination - Manual Svc Order - Disconnect - Add'l	SOMAN	NA	NA	GA	NA	\$8.06	NA	NA	NA	NA
	STS-1 Interoffice Channel and DS1 Local Loop:										
	DS1 Loop per month, State wide	USLXX	NA	\$96.46	\$60.88	NA	\$72.86	NA	\$151.50	NA	NA
	DS1 Loop per mile, statewide	1L5ND	NA	\$0.00	\$0.00	NA	\$0.00	NA	\$0.00	NA	\$0.00
	DS1 Loop per month, Zone 1 (Note 1)	TBD	NA	TBD	\$22.88	NA	TBD	NA	TBD	NA	TBD
	DS1 Loop per month, Zone 2 (Note 1)	TBD	NA	TBD	\$26.42	NA	TBD	NA	TBD	NA	TBD
	DS1 Loop per month, Zone 3 (Note 1)	TBD	NA	TBD	\$41.99	NA	TBD	NA	TBD	NA	TBD
	DS1 Loop per month, Zone 4 (Note 1)	NA	NA	NA	NA	NA	NA	NA	NA	NA	NA
	Interoffice Channel - Dedicated - STS-1 - Facility Termination per month	U1TFS	NA	\$449.40	\$966.49	NA	\$1,000.00	NA	\$428.93	NA	\$840.61
	Interoffice Channel - Dedicated - STS-1 - per mile per month	1L5XX	NA	\$11.97	\$10.25	NA	\$6.78	NA	\$11.40	NA	\$6.88
	DS3 Channelized System per month	MQ3	NA	\$222.61	\$202.91	NA	\$244.37	NA	\$236.35	NA	\$225.59
	DS3 Interface per month (DS1 COCI)	UC1D1	NA	\$14.51	\$0.67	NA	\$15.49	NA	\$16.29	NA	\$3.91
	Non-Recurring Charges - New EEL (Note 2)(Note 3)										
	NRC-DS1 Local Loop - 1st	USLXX	NA	\$434.24	\$429.98	NA	\$502.73	NA	\$568.96	NA	TBD

BELLSOUTH/LEVEL 3 RATES
NETWORK ELEMENTS
AND OTHER SERVICES

	USOC	AL	FL	GA	KY	LA	MS	NC	SC	TN
NRC-DS1 Local Loop - Add'l	USLXX	NA	\$235.29	\$268.18	NA	\$293.92	NA	\$335.56	NA	TBD
NRC- STS-1 interoffice - 1st	U1TFS	NA	\$682.89	\$761.81	NA	\$589.06	NA	\$624.86	NA	\$1,012.52
NRC- STS-1 interoffice - Add'l	U1TFS	NA	\$288.32	\$545.54	NA	\$418.42	NA	\$436.36	NA	\$655.99
NRC-DS3 Channelization System -1st	MQ3	NA	\$240.04	\$251.45	NA	\$314.72	NA	\$331.54	NA	\$326.17
NRC-DS3 Channelization System - Add'l	MQ3	NA	\$106.82	\$485.61	NA	\$224.70	NA	\$241.81	NA	\$236.25
NRC-DS1(COCl)interface card -1st	UC1D1	NA	\$12.26	\$12.15	NA	\$11.18	NA	\$12.39	NA	\$12.61
NRC-DS1(COCl)interface card -Add'l	UC1D1	NA	\$8.84	\$8.76	NA	\$8.06	NA	\$8.93	NA	\$9.03
NRC-STS-1 interoffice channel and DS1 Local Loop Combination - Electronic Svc Order, per LSR	SOMEK	NA	\$3.20	\$3.50	NA	\$3.50	NA	\$3.50	NA	\$3.50
NRC-STS-1 interoffice channel and DS1 Local Loop Combination - Manual Svc Order, per LSR	SOMAN	NA	\$25.60	NA	NA	NA	NA	NA	NA	NA
NRC-STS-1 interoffice channel and DS1 Local Loop Combination - Manual Svc Order - 1st	SOMAN	NA	NA	\$56.49	NA	\$53.06	NA	\$55.00	NA	NA
NRC-STS-1 interoffice channel and DS1 Local Loop Combination - Manual Svc Order - Add'l	SOMAN	NA	NA	\$45.97	NA	\$42.98	NA	\$55.00	NA	NA
NRC-STS-1 interoffice channel and DS1 Local Loop Combination - Manual Svc Order - Disconnect - 1st	SOMAN	NA	NA	\$36.97	NA	\$46.32	NA	NA	NA	NA
NRC-STS-1 interoffice channel and DS1 Local Loop Combination - Manual Svc Order - Disconnect - Add'l	SOMAN	NA	NA	\$26.45	NA	\$24.83	NA	NA	NA	NA
2-wire VG Interoffice Channel and 2-wire Local Loop:										
2-wire VG Loop per month, statewide	UEAL2	NA	\$17.88	\$17.89	NA	\$22.84	NA	NA	NA	\$26.02
2-wire VG Loop per mile, statewide	1L5ND	NA	\$0.00	\$0.00	NA	\$0.00	NA	\$0.00	NA	\$0.00
2-wire VG Loop per month, Zone 1 (Note 1)	TBD	NA	TBD	TBD	NA	TBD	NA	TBD	NA	TBD
2-wire VG Loop per month, Zone 2 (Note 1)	TBD	NA	TBD	TBD	NA	TBD	NA	NA	NA	TBD
2-wire VG Loop per month, Zone 3 (Note 1)	TBD	NA	TBD	TBD	NA	TBD	NA	NA	NA	TBD
2-wire VG Loop per month, Zone 4 (Note 1)	NA	NA	NA	NA	NA	NA	NA	NA	NA	NA
Interoffice Channel - Dedicated - 2-wire VG - Facility Termination per month	U1TV2	NA	\$26.72	\$17.07	NA	\$19.10	NA	\$18.01	NA	\$18.33
Interoffice Channel - Dedicated - 2-wire VG - per mile per month	1L5XX	NA	\$0.0100	\$0.02	NA	\$0.04	NA	\$0.03	NA	\$0.02
Non-Recurring Charges - New EEL (Note 2)(Note 3)										
NRC- 2-wire VG interoffice - 1st	U1TV2	NA	\$222.65	\$79.61	NA	\$104.23	NA	\$137.48	NA	\$83.35
NRC- 2-wire VG interoffice - Add'l	U1TV2	NA	\$118.83	\$36.08	NA	\$39.91	NA	\$52.58	NA	\$20.88
NRC-2-wire VG Local Loop - 1st	UEAL2	NA	\$271.29	\$104.17	NA	\$128.42	NA	NA	NA	\$192.97
NRC-2-wire VG Local Loop - Add'l	UEAL2	NA	\$104.90	\$78.10	NA	\$93.60	NA	NA	NA	\$140.72
NRC-2-wire VG interoffice channel and 2-wire VG Local Loop Combination - Electronic Svc Order, per LSR	SOMEK	NA	\$3.20	\$3.50	NA	\$3.50	NA	\$3.50	NA	\$3.50
NRC-2-wire VG interoffice channel and 2-wire VG Local Loop Combination - Manual Svc Order, per LSR	SOMAN	NA	\$25.60	NA	NA	NA	NA	NA	NA	\$19.99
NRC-2-wire VG interoffice channel and 2-wire VG Local Loop Combination - Manual Svc Order - 1st	SOMAN	NA	NA	\$37.88	NA	\$36.28	NA	\$38.07	NA	NA
NRC-2-wire VG interoffice channel and 2-wire VG Local Loop Combination - Manual Svc Order - Add'l	SOMAN	NA	NA	\$27.36	NA	\$26.20	NA	\$38.07	NA	NA
NRC-2-wire VG interoffice channel and 2-wire VG Local Loop Combination - Manual Svc Order - Disconnect - 1st	SOMAN	NA	NA	NA	NA	\$19.47	NA	NA	NA	NA
NRC-2-wire VG interoffice channel and 2-wire VG Local Loop Combination - Manual Svc Order - Disconnect - Add'l	SOMAN	NA	NA	NA	NA	\$8.06	NA	NA	NA	NA
4-wire VG Interoffice Channel and 4-wire Local Loop:										
4-wire VG Loop per month, statewide	UEAL4	NA	\$31.02	NA	NA	NA	NA	\$27.20	NA	NA
4-wire VG Loop per mile, statewide	1L5ND	NA	\$0.00	\$0.00	NA	\$0.00	NA	\$0.00	NA	\$0.00
4-wire VG Loop per month, Zone 1 (Note 1)	TBD	NA	TBD	TBD	NA	TBD	NA	TBD	NA	TBD
4-wire VG Loop per month, Zone 2 (Note 1)	TBD	NA	TBD	TBD	NA	TBD	NA	TBD	NA	TBD
4-wire VG Loop per month, Zone 3 (Note 1)	TBD	NA	TBD	TBD	NA	TBD	NA	TBD	NA	TBD
4-wire VG Loop per month, Zone 4 (Note 1)	NA	NA	NA	NA	NA	NA	NA	NA	NA	NA

BELLSOUTH/LEVEL 3 RATES
NETWORK ELEMENTS
AND OTHER SERVICES

		USOC	AL	FL	GA	KY	LA	MS	NC	SC	TN
	Interoffice Channel - Dedicated - 4-wire VG - FacilityTermination per month	U1TV4	NA	\$23.82	NA	NA	NA	NA	NA	NA	NA
	Interoffice Channel - Dedicated - 4-wire VG - per mile per month	1L5XX	NA	\$0.0100	NA	NA	NA	NA	NA	NA	NA
	Non-Recurring Charges - New EEL (Note 2)(Note 3)										
	NRC- 4-wire VG interoffice - 1st	U1TV4	NA	\$222.65	NA	NA	NA	NA	NA	NA	NA
	NRC- 4-wire VG interoffice - Add'l	U1TV4	NA	\$118.83	NA	NA	NA	NA	NA	NA	NA
	NRC-4-wire VG Local Loop - 1st	UEAL4	NA	\$271.29	NA	NA	NA	NA	\$86.50	NA	NA
	NRC-4-wire VG Local Loop - Add'l	UEAL4	NA	\$104.90	NA	NA	NA	NA	\$27.80	NA	NA
	NRC-4-wire VG interoffice channel and 4-wire VG Local Loop Combination - Electronic Svc Order, per LSR	SOMEK	NA	\$3.20	NA	NA	NA	NA	\$3.50	NA	NA
	NRC-4-wire VG interoffice channel and 4-wire VG Local Loop Combination - Manual Svc Order, per LSR	SOMAN	NA	\$25.60	NA	NA	NA	NA	NA	NA	NA
	NRC-4-wire VG interoffice channel and 4-wire VG Local Loop Combination - Manual Svc Order - 1st	SOMAN	NA	NA	NA	NA	NA	NA	NA	NA	NA
	NRC-4-wire VG interoffice channel and 4-wire VG Local Loop Combination - Manual Svc Order - Add'l	SOMAN	NA	NA	NA	NA	NA	NA	NA	NA	NA
	NRC-4-wire VG interoffice channel and 4-wire VG Local Loop Combination - Manual Svc Order - Disconnect - 1st	SOMAN	NA	NA	NA	NA	NA	NA	NA	NA	NA
	NRC-4-wire VG interoffice channel and 4-wire VG Local Loop Combination - Manual Svc Order - Disconnect - add'l	SOMAN	NA	NA	NA	NA	NA	NA	NA	NA	NA
	4-wire 56 kbps Interoffice Channel and 4-wire 56kbps Local Loop:	USOC	AL	FL	GA	KY	LA	MS	NC	SC	TN
	4-wire 56kbps Loop per month, statewide	UDL56	NA	\$36.98	\$29.92	NA	\$35.58	NA	\$40.12	NA	\$42.23
	4-wire 56kbps Loop per mile, statewide	1L5ND	NA	\$0.00	\$0.00	NA	\$0.00	NA	\$0.00	NA	\$0.00
	4-wire 56kbps Loop per month, Zone 1 (Note 1)	TBD	NA	TBD	TBD	NA	TBD	NA	TBD	NA	TBD
	4-wire 56kbps Loop per month, Zone 2 (Note 1)	TBD	NA	TBD	TBD	NA	TBD	NA	TBD	NA	TBD
	4-wire 56kbps Loop per month, Zone 3 (Note 1)	TBD	NA	TBD	TBD	NA	TBD	NA	TBD	NA	TBD
	4-wire 56kbps Loop per month, Zone 4 (Note 1)	NA	NA	NA	NA	NA	NA	NA	NA	NA	NA
	Interoffice Channel - Dedicated - 4-wire 56kbps - FacilityTermination per month	U1TD6	NA	\$23.82	\$16.45	NA	\$18.37	NA	\$17.40	NA	\$17.74
	Interoffice Channel - Dedicated - 4-wire 56kbps - per mile per month	1L5XX	NA	\$0.0100	\$0.02	NA	\$0.04	NA	\$0.03	NA	\$0.17
	Non-Recurring Charges - New EEL (Note 2)(Note 3)										
	NRC- 4-wire 56kbps interoffice - 1st	U1TD6	NA	\$222.65	\$79.61	NA	\$104.23	NA	\$137.48	NA	\$83.35
	NRC- 4-wire 56kbps interoffice - Add'l	U1TD6	NA	\$118.83	\$36.08	NA	\$39.91	NA	\$52.58	NA	\$20.88
	NRC-4-wire 56kbps Local Loop - 1st	UDL56	NA	\$271.29	\$348.55	NA	\$421.27	NA	\$642.74	NA	\$643.00
	NRC-4-wire 56kbps Local Loop - Add'l	UDL56	NA	\$104.90	\$241.20	NA	\$274.74	NA	\$421.02	NA	\$421.28
	NRC-4-wire 56kbps interoffice channel and 4-wire 56kbps Local Loop Combination - Electronic Svc Order, per LSR	SOMEK	NA	\$3.20	\$3.50	NA	\$3.50	NA	\$3.50	NA	\$3.50
	NRC-4-wire 56kbps interoffice channel and 4-wire 56kbps Local Loop Combination - Manual Svc Order, per LSR	SOMAN	NA	\$25.60	NA	NA	NA	NA	NA	NA	\$19.99
	NRC-4-wire 56kbps interoffice channel and 4-wire 56kbps Local Loop Combination - Manual Svc Order - 1st	SOMAN	NA	NA	\$37.88	NA	\$36.28	NA	\$38.07	NA	NA
	NRC-4-wire 56kbps interoffice channel and 4-wire 56kbps Local Loop Combination - Manual Svc Order - Add'l	SOMAN	NA	NA	\$27.36	NA	\$26.20	NA	\$38.07	NA	NA
	NRC-4-wire 56kbps interoffice channel and 4-wire 56kbps Local Loop Combination - Manual Svc Order - Disconnect - 1st	SOMAN	NA	NA	NA	NA	\$11.41	NA	NA	NA	NA
	NRC-4-wire 56kbps interoffice channel and 4-wire 56kbps Local Loop Combination - Manual Svc Order - Disconnect - Add'l	SOMAN	NA	NA	NA	NA	NA	NA	NA	NA	NA
	4-wire 64 kbps Interoffice Channel and 4-wire 64 kbps Local Loop:	USOC	AL	FL	GA	KY	LA	MS	NC	SC	TN
	4-wire 64kbps Loop per month, statewide	UDL64	NA	\$36.98	\$30.72	NA	\$35.58	NA	\$40.12	NA	\$42.23
	4-wire 64kbps Loop per mile, statewide	1L5ND	NA	\$0.00	\$0.00	NA	\$0.00	NA	\$0.00	NA	\$0.00
	4-wire 64kbps Loop per month, Zone 1 (Note 1)	TBD	NA	TBD	TBD	NA	TBD	NA	TBD	NA	TBD
	4-wire 64kbps Loop per month, Zone 2 (Note 1)	TBD	NA	TBD	TBD	NA	TBD	NA	TBD	NA	TBD
	4-wire 64kbps Loop per month, Zone 3 (Note 1)	TBD	NA	TBD	TBD	NA	TBD	NA	TBD	NA	TBD

BELLSOUTH/LEVEL 3 RATES
NETWORK ELEMENTS
AND OTHER SERVICES

		USOC	AL	FL	GA	KY	LA	MS	NC	SC	TN
	4-wire 64kbps Loop per month, Zone 4 (Note 1)	NA	NA	NA	NA	NA	NA	NA	NA	NA	NA
	Interoffice Channel - Dedicated - 4-wire 64kbps - Facility Termination per month	U1TD6	NA	\$19.46	\$16.45	NA	\$18.37	NA	\$17.40	NA	\$17.74
	Interoffice Channel - Dedicated - 4-wire 64kbps - per mile per month	1L5XX	NA	\$0.0100	\$0.02	NA	\$0.04	NA	\$0.03	NA	\$0.17
	Non-Recurring Charges - New EEL (Note 2)(Note 3)										
	NRC- 4-wire 64kbps interoffice - 1st	U1TD6	NA	\$222.65	\$674.50	NA	\$589.06	NA	\$137.48	NA	\$877.70
	NRC- 4-wire 64kbps interoffice - Add'l	U1TD6	NA	\$118.83	\$437.35	NA	\$418.42	NA	\$52.58	NA	\$540.32
	NRC-4-wire 64kbps Local Loop - 1st	UDL64	NA	\$271.29	\$761.81	NA	\$696.86	NA	\$642.74	NA	\$829.52
	NRC-4-wire 64kbps Local Loop - Add'l	UDL64	NA	\$104.90	\$545.54	NA	\$496.00	NA	\$421.02	NA	\$512.23
	NRC-4-wire 64kbps interoffice channel and 4-wire 64kbps Local Loop Combination - Electronic Svc Order, per LSR	SOMEK	NA	\$3.20	\$3.50	NA	\$3.50	NA	\$3.50	NA	\$3.50
	NRC-4-wire 64kbps interoffice channel and 4-wire 64kbps Local Loop Combination - Manual Svc Order, per LSR	SOMAN	NA	\$25.60	NA	NA	NA	NA	NA	NA	\$19.99
	NRC-4-wire 64kbps interoffice channel and 4-wire 64kbps Local Loop Combination - Manual Svc Order - 1st	SOMAN	NA	NA	\$37.55	NA	\$69.84	NA	\$38.07	NA	NA
	NRC-4-wire 64kbps interoffice channel and 4-wire 64kbps Local Loop Combination - Manual Svc Order - Add'l	SOMAN	NA	NA	\$37.55	NA	\$69.84	NA	\$38.07	NA	NA
	NRC-4-wire 64kbps interoffice channel and 4-wire 64kbps Local Loop Combination - Manual Svc Order - Disconnect - 1st	SOMAN	NA	NA	\$18.03	NA	\$37.71	NA	NA	NA	NA
	NRC-4-wire 64kbps interoffice channel and 4-wire 64kbps Local Loop Combination - Manual Svc Order - Disconnect - Add'l	SOMAN	NA	NA	\$18.03	NA	\$37.71	NA	NA	NA	NA
	Network Elements used in Dedicated Transport Combinations at UNE Rates (Note4)										
	Local Channels:										
	Local Channel - Dedicated - 2-Wire VG										
	Monthly Recurring per month	ULDV2	\$14.61	\$26.31	\$18.28	\$22.26	\$14.94	\$17.83	\$14.83	\$16.83	\$19.02
	per mile per month	1L5NC	\$0.00	\$0.00	\$0.00	\$0.00	\$0.00	\$0.00	\$0.00	\$0.00	\$0.00
	Zone 1	TBD	NA	NA	\$11.91	NA	NA	NA	NA	NA	\$16.42
	Zone 2	TBD	NA	NA	\$13.83	NA	NA	NA	NA	NA	\$20.66
	Zone 3	TBD	NA	NA	\$21.98	NA	NA	NA	NA	NA	\$29.61
	Zone 4	TBD	NA	NA	NA	NA	NA	NA	NA	NA	NA
	NRC - Ordinarily Combined in GA:										
	NRC - 2-wire VG Local Channel - 1st	ULDV2	NA	NA	\$307.54	NA	NA	NA	NA	NA	NA
	NRC - 2-wire VG Local Channel - Add'l	ULDV2	NA	NA	\$73.78	NA	NA	NA	NA	NA	NA
	NRC - Electronic Svc Order, per LSR	SOMEK	NA	NA	\$3.50	NA	NA	NA	NA	NA	NA
	NRC - 2-Wire VG - Incremental Charge--Manual Svc Order - 1st	SOMAN	NA	NA	\$34.00	NA	NA	NA	NA	NA	NA
	NRC - 2-Wire VG - Incremental Charge--Manual Svc Order - Add'l	SOMAN	NA	NA	\$21.58	NA	NA	NA	NA	NA	NA
	NRC - 2-Wire VG - Incremental Charge--Manual Svc Order - Disconnect - 1st	SOMAN	NA	NA	\$22.48	NA	NA	NA	NA	NA	NA
	NRC - 2-Wire VG - Incremental Charge--Manual Svc Order - Disconnect - Add'l	SOMAN	NA	NA	\$8.17	NA	NA	NA	NA	NA	NA
	NRC-All Existing Combination "Switch As Is" Conversion Charge										
	NRC-2/4-WIRE VG COMBINATION - "Switch As Is" Conversion Charge - 1st	UNCCC	\$54.03	\$11.27	\$58.43	\$54.09	\$54.23	\$54.09	\$54.00	\$54.26	\$54.13
	NRC-2/4-WIRE VG COMBINATION - "Switch As Is" Conversion Charge - Add'l	UNCCC	\$32.11	\$11.27	\$26.99	\$32.16	\$32.24	\$32.16	\$32.10	\$32.25	\$32.17
	NRC- 2/4-WIRE VG COMBINATION - "Switch As Is" Conversion Charge - Disconnect - 1st	UNCCC	\$0.00	\$13.03	\$12.61	\$0.00	\$0.00	\$0.00	\$0.00	\$0.00	\$0.00
	NRC- 2/4-WIRE VG COMBINATION - "Switch As Is" Conversion Charge - Disconnect - Add'l	UNCCC	\$0.00	\$13.03	\$12.61	\$0.00	\$0.00	\$0.00	\$0.00	\$0.00	\$0.00
	Local Channel - Dedicated - 4-Wire VG										
	Monthly Recurring per month	ULDV4	\$15.77	\$27.48	\$17.18	\$23.38	\$16.21	\$19.03	\$15.87	\$18.05	\$20.14
	per mile per month	1L5NC	\$0.00	\$0.00	\$0.00	\$0.00	\$0.00	\$0.00	\$0.00	\$0.00	\$0.00

BELLSOUTH/LEVEL 3 RATES
NETWORK ELEMENTS
AND OTHER SERVICES

		USOC	AL	FL	GA	KY	LA	MS	NC	SC	TN
	Zone 1	TBD	NA	NA	\$12.90	NA	NA	NA	NA	NA	\$17.38
	Zone 2	TBD	NA	NA	\$14.90	NA	NA	NA	NA	NA	\$21.88
	Zone 3	TBD	NA	NA	\$23.68	NA	NA	NA	NA	NA	\$31.36
	Zone 4	TBD	NA	NA	NA	NA	NA	NA	NA	NA	NA
	NRC - Ordinarily Combined in GA:										
	NRC-4-wire VG Local Channel - 1st	ULDV4	NA	NA	\$307.54	NA	NA	NA	NA	NA	NA
	NRC-4-wire VG Local Channel - Add'l	ULDV4	NA	NA	\$73.78	NA	NA	NA	NA	NA	NA
	NRC - Electronic Svc Order, per LSR	SOMEK	NA	NA	\$3.50	NA	NA	NA	NA	NA	NA
	NRC - 4-Wire VG Local Channel - Incremental Charge--Manual Svc Order - 1st	SOMAN	NA	NA	\$34.00	NA	NA	NA	NA	NA	NA
	NRC - 4-Wire VG Local Channel - Incremental Charge--Manual Svc Order - Add'l	SOMAN	NA	NA	\$21.58	NA	NA	NA	NA	NA	NA
	NRC - 4-Wire VG Local Channel - Incremental Charge--Manual Svc Order - Disconnect - 1st	SOMAN	NA	NA	\$22.48	NA	NA	NA	NA	NA	NA
	NRC - 4-Wire VG Local Channel - Incremental Charge--Manual Svc Order - Disconnect - Add'l	SOMAN	NA	NA	\$8.17	NA	NA	NA	NA	NA	NA
	NRC-All Existing Combination "Switch As Is" Conversion Charge										
	NRC-2/4-WIRE VG COMBINATION - "Switch As Is" Conversion Charge - 1st	UNCCC	\$54.03	\$11.27	\$58.43	\$54.09	\$54.23	\$54.09	\$54.00	\$54.26	\$54.13
	NRC-2/4-WIRE VG COMBINATION - "Switch As Is" Conversion Charge - Add'l	UNCCC	\$32.11	\$11.27	\$26.99	\$32.16	\$32.24	\$32.16	\$32.10	\$32.25	\$32.17
	NRC- 2/4-WIRE VG COMBINATION - "Switch As Is" Conversion Charge - Disconnect - 1st	UNCCC	\$0.00	\$13.03	\$12.61	\$0.00	\$0.00	\$0.00	\$0.00	\$0.00	\$0.00
	NRC- 2/4-WIRE VG COMBINATION - "Switch As Is" Conversion Charge - Disconnect - Add'l	UNCCC	\$0.00	\$13.03	\$12.61	\$0.00	\$0.00	\$0.00	\$0.00	\$0.00	\$0.00
	Local Channel - Dedicated - DS1										
	DS1 Monthly Recurring per month	ULDF1	\$35.52	\$42.98	\$38.57	\$43.80	\$43.80	\$38.91	\$35.68	\$37.20	\$40.27
	per mile per month	1L5NC	\$0.00	\$0.00	\$0.00	\$0.00	\$0.00	\$0.00	\$0.00	\$0.00	\$0.00
	Zone 1	TBD	NA	NA	\$33.02	NA	NA	NA	NA	NA	\$34.76
	Zone 2	TBD	NA	NA	\$38.13	NA	NA	NA	NA	NA	\$43.75
	Zone 3	TBD	NA	NA	\$60.60	NA	NA	NA	NA	NA	\$62.70
	Zone 4	TBD	NA	NA	NA	NA	NA	NA	NA	NA	NA
	NRC - Ordinarily Combined in GA:										
	NRC - DS1 Local Channel - 1st	ULDF1	NA	NA	\$162.03	NA	NA	NA	NA	NA	NA
	NRC - DS1 Local Channel - Add'l	ULDF1	NA	NA	\$107.76	NA	NA	NA	NA	NA	NA
	NRC - Electronic Svc Order, per LSR	SOMEK	NA	NA	\$3.50	NA	NA	NA	NA	NA	NA
	NRC - DS1 Local Channel - Incremental Charge--Manual Svc Order - 1st	SOMAN	NA	NA	\$34.00	NA	NA	NA	NA	NA	NA
	NRC - DS1 Local Channel - Incremental Charge--Manual Svc Order - Add'l	SOMAN	NA	NA	\$21.58	NA	NA	NA	NA	NA	NA
	NRC - DS1 Local Channel - Incremental Charge--Manual Svc Order - Disconnect - 1st	SOMAN	NA	NA	\$22.48	NA	NA	NA	NA	NA	NA
	NRC - DS1 Local Channel - Incremental Charge--Manual Svc Order - Disconnect - Add'l	SOMAN	NA	NA	\$8.17	NA	NA	NA	NA	NA	NA
	NRC-All Existing Combination "Switch As Is" Conversion Charge										
	NRC-DS1 COMBINATION - "Switch As Is" Conversion Charge - 1st	UNCCC	\$54.03	\$11.27	\$58.43	\$54.09	\$54.23	\$54.09	\$54.00	\$54.26	\$54.13
	NRC-DS1 COMBINATION - "Switch As Is" Conversion Charge - Add'l	UNCCC	\$32.11	\$11.27	\$26.99	\$32.16	\$32.24	\$32.16	\$32.10	\$32.25	\$32.17
	NRC- DS1 COMBINATION - "Switch As Is" Conversion Charge - Disconnect - 1st	UNCCC	\$0.00	\$13.03	\$12.61	\$0.00	\$0.00	\$0.00	\$0.00	\$0.00	\$0.00
	NRC- DS1 COMBINATION - "Switch As Is" Conversion Charge - Disconnect - Add'l	UNCCC	\$0.00	\$13.03	\$12.61	\$0.00	\$0.00	\$0.00	\$0.00	\$0.00	\$0.00
	Local Channel - Dedicated - DS3										

BELLSOUTH/LEVEL 3 RATES
NETWORK ELEMENTS
AND OTHER SERVICES

		USOC	AL	FL	GA	KY	LA	MS	NC	SC	TN
	DS3 Local Channel - per mile per month	1L5NC	\$8.44	\$9.32	\$6.92	\$34.00	\$8.77	NA	NA	\$12.08	\$23.76
	DS3 Local Channel - Facility Termination per month	ULDF3	\$525.40	\$560.39	\$517.56	\$610.64	\$558.00	\$531.39	\$512.00	\$481.14	\$615.65
	NRC - Ordinarily Combined in GA:										
	NRC - DS3 Local Channel Facility Termination - 1st	ULDF3	NA	NA	\$761.81	NA	NA	NA	NA	NA	NA
	NRC - DS3 Local Channel - Facility Termination - Add'l	ULDF3	NA	NA	\$545.54	NA	NA	NA	NA	NA	NA
	NRC - Electronic Svc Order, per LSR	SOMEK	NA	NA	\$3.50	NA	NA	NA	NA	NA	NA
	NRC - DS3 Local Channel - Incremental Charge--Manual Svc Order - 1st	SOMAN	NA	NA	\$66.21	NA	NA	NA	NA	NA	NA
	NRC - DS3 Local Channel - Incremental Charge--Manual Svc Order - Add'l	SOMAN	NA	NA	\$33.90	NA	NA	NA	NA	NA	NA
	NRC - DS3 Local Channel - Incremental Charge--Manual Svc Order - Disconnect - 1st	SOMAN	NA	NA	\$36.15	NA	NA	NA	NA	NA	NA
	NRC - DS3 Local Channel - Incremental Charge--Manual Svc Order - Disconnect - Add'l	SOMAN	NA	NA	\$14.20	NA	NA	NA	NA	NA	NA
	NRC-All Existing Combination "Switch As Is" Conversion Charge										
	NRC-DS3 COMBINATION - "Switch As Is" Conversion Charge - 1st	UNCCC	\$54.03	\$11.27	\$71.04	\$54.09	\$54.23	\$54.09	\$54.00	\$54.26	\$54.13
	NRC-DS3 COMBINATION - "Switch As Is" Conversion Charge - Add'l	UNCCC	\$32.11	\$11.27	\$39.60	\$32.16	\$32.24	\$32.16	\$32.10	\$32.25	\$32.17
	NRC- DS3 COMBINATION - "Switch As Is" Conversion Charge - Disconnect - 1st	UNCCC	\$0.00	\$13.03	\$0.00	\$0.00	\$0.00	\$0.00	\$0.00	\$0.00	\$0.00
	NRC- DS3 COMBINATION - "Switch As Is" Conversion Charge - Disconnect - Add'l	UNCCC	\$0.00	\$13.03	\$0.00	\$0.00	\$0.00	\$0.00	\$0.00	\$0.00	\$0.00
	Local Channel - Dedicated - STS-1										
	STS-1 Local Channel - per mile per month	1L5NC	\$8.44	\$9.32	\$6.92	\$30.04	\$8.77	\$38.98	NA	\$12.08	\$25.11
	STS-1 Local Channel - Facility Termination per month	ULDFS	\$525.40	\$569.67	\$517.56	\$610.64	\$558.00	\$531.39	\$512.00	\$481.14	\$615.65
	NRC - Ordinarily Combined in GA:										
	NRC - STS-1 Local Channel Facility Termination - 1st	ULDFS	NA	NA	\$761.81	NA	NA	NA	NA	NA	NA
	NRC - STS-1 Local Channel - Facility Termination - Add'l	ULDFS	NA	NA	\$545.54	NA	NA	NA	NA	NA	NA
	NRC - Electronic Svc Order, per LSR	SOMEK	NA	NA	\$3.50	NA	NA	NA	NA	NA	NA
	NRC - STS-1 Local Channel - Incremental Charge--Manual Svc Order - 1st	SOMAN	NA	NA	\$37.55	NA	NA	NA	NA	NA	NA
	NRC - STS-1 Local Channel - Incremental Charge--Manual Svc Order - Add'l	SOMAN	NA	NA	\$37.55	NA	NA	NA	NA	NA	NA
	NRC - STS-1 Local Channel - Incremental Charge--Manual Svc Order - Disconnect - 1st	SOMAN	NA	NA	\$18.03	NA	NA	NA	NA	NA	NA
	NRC - STS-1 Local Channel - Incremental Charge--Manual Svc Order - Disconnect - Add'l	SOMAN	NA	NA	\$18.03	NA	NA	NA	NA	NA	NA
	NRC-All Existing Combination "Switch As Is" Conversion Charge										
	NRC-STS-1 COMBINATION - "Switch As Is" Conversion Charge - 1st	UNCCC	\$54.03	\$11.27	\$58.43	\$54.09	\$54.23	\$54.09	\$54.00	\$54.26	\$54.13
	NRC-STS-1 COMBINATION - "Switch As Is" Conversion Charge - Add'l	UNCCC	\$32.11	\$11.27	\$26.99	\$32.16	\$32.24	\$32.16	\$32.10	\$32.25	\$32.17
	NRC- STS-1 COMBINATION - "Switch As Is" Conversion Charge - Disconnect - 1st	UNCCC	\$0.00	\$13.03	\$12.61	\$0.00	\$0.00	\$0.00	\$0.00	\$0.00	\$0.00
	NRC- STS-1 COMBINATION - "Switch As Is" Conversion Charge - Disconnect - Add'l	UNCCC	\$0.00	\$13.03	\$12.61	\$0.00	\$0.00	\$0.00	\$0.00	\$0.00	\$0.00
	Local Channel - OC3										
	Local Channel - OC3 - per Mile	TBA	\$8.23	\$7.83	\$6.75	\$33.15	\$29.58	\$41.27	\$24.69	\$11.78	\$23.16
	Local Channel - OC3 - per Facility Termination	TBA	\$691.33	\$940.35	\$630.21	\$713.29	\$753.65	\$689.68	\$611.36	\$701.71	\$620.20
	NRC - Ordinarily Combined in GA:										
	NRC - OC3 - Facility Termination - 1st	TBA	NA	NA	\$947.69	NA	NA	NA	NA	NA	NA
	NRC - OC3 - Facility Termination - Add'l	TBA	NA	NA	\$413.00	NA	NA	NA	NA	NA	NA
	NRC - OC3 - Facility Termination - Disconnect - 1st	TBA	NA	NA	\$122.31	NA	NA	NA	NA	NA	NA
	NRC - OC3 - Facility Termination - Disconnect - Add'l	TBA	NA	NA	\$119.14	NA	NA	NA	NA	NA	NA

BELLSOUTH/LEVEL 3 RATES
NETWORK ELEMENTS
AND OTHER SERVICES

		USOC	AL	FL	GA	KY	LA	MS	NC	SC	TN
	NRC - Electronic Svc Order, per LSR	SOME C	NA	NA	\$3.50	NA	NA	NA	NA	NA	NA
	NRC - OC3 - Incremental Charge-Manual Svc Order - 1st	SOMAN	NA	NA	\$37.55	NA	NA	NA	NA	NA	NA
	NRC - OC3 - Incremental Charge-Manual Svc Order - Add'l	SOMAN	NA	NA	\$37.55	NA	NA	NA	NA	NA	NA
	NRC - OC3 -Incremental Cost - Manual Svc. Order vs. Elect-Disconnect-1st	SOMAN	NA	NA	\$18.03	NA	NA	NA	NA	NA	NA
	NRC - OC3 -Incremental Cost - Manual Svc. Order vs. Elect-Disconnect-Add'l	SOMAN	NA	NA	\$18.03	NA	NA	NA	NA	NA	NA
	NRC-All Existing Combination "Switch As Is" Conversion Charge										
	NRC-OC-3 COMBINATION - "Switch As Is" Conversion Charge - 1st	UNCCC	\$54.03	\$11.27	\$58.43	\$54.09	\$54.23	\$54.09	\$54.00	\$54.26	\$54.13
	NRC-OC-3 COMBINATION - "Switch As Is" Conversion Charge - Add'l	UNCCC	\$32.11	\$11.27	\$26.99	\$32.16	\$32.24	\$32.16	\$32.10	\$32.25	\$32.17
	NRC - OC-3 COMBINATION - "Switch As Is" Conversion Charge - Disconnect - 1st	UNCCC	\$0.00	\$13.03	\$12.61	\$0.00	\$0.00	\$0.00	\$0.00	\$0.00	\$0.00
	NRC - OC-3 COMBINATION - "Switch As Is" Conversion Charge - Disconnect - Add'l	UNCCC	\$0.00	\$13.03	\$12.61	\$0.00	\$0.00	\$0.00	\$0.00	\$0.00	\$0.00
	Local Channel - OC12										
	Local Channel - OC12 - per Mile	TBA	\$10.13	\$11.18	\$8.31	\$40.80	\$36.40	\$50.79	\$30.38	\$14.50	\$28.51
	Local Channel - OC12 - per Facility Termination	TBA	\$2,557	\$2,753	\$2,109.00	\$2,457	\$2,571	\$2,371	\$2,122	\$2,663	\$2,079
	NRC - Ordinarily Combined in GA:										
	NRC - OC12 - Facility Termination - 1st	TBA	NA	NA	\$1,162.00	NA	NA	NA	NA	NA	NA
	NRC - OC12 - Facility Termination - Add'l	TBA	NA	NA	\$413.00	NA	NA	NA	NA	NA	NA
	NRC - OC12 - Facility Termination - Disconnect - 1st	TBA	NA	NA	\$122.31	NA	NA	NA	NA	NA	NA
	NRC - OC12 - Facility Termination - Disconnect - Add'l	TBA	NA	NA	\$119.14	NA	NA	NA	NA	NA	NA
	NRC - Electronic Svc Order, per LSR	SOME C	NA	NA	\$3.50	NA	NA	NA	NA	NA	NA
	NRC -OC12 - Incremental Charge - Manual Svc Order - 1st	SOMAN	NA	NA	\$37.55	NA	NA	NA	NA	NA	NA
	NRC - OC12 - Incremental Charge - Manual Svc Order - Add'l	SOMAN	NA	NA	\$37.55	NA	NA	NA	NA	NA	NA
	NRC - OC12 - Incremental Cost-Manual Svc. Order vs. Elect-Disconnect-1st	SOMAN	NA	NA	\$18.03	NA	NA	NA	NA	NA	NA
	NRC - OC12 - Incremental Cost-Manual Svc. Order vs. Elect-Disconnect-Add'l	SOMAN	NA	NA	\$18.03	NA	NA	NA	NA	NA	NA
	NRC-All Existing Combination "Switch As Is" Conversion Charge										
	NRC-OC-12 COMBINATION - "Switch As Is" Conversion Charge - 1st	UNCCC	\$54.03	\$11.27	\$58.43	\$54.09	\$54.23	\$54.09	\$54.00	\$54.26	\$54.13
	NRC-OC-12 COMBINATION - "Switch As Is" Conversion Charge - Add'l	UNCCC	\$32.11	\$11.27	\$26.99	\$32.16	\$32.24	\$32.16	\$32.10	\$32.25	\$32.17
	NRC - OC-12 COMBINATION - "Switch As Is" Conversion Charge - Disconnect - 1st	UNCCC	\$0.00	\$13.03	\$12.61	\$0.00	\$0.00	\$0.00	\$0.00	\$0.00	\$0.00
	NRC - OC-12 COMBINATION - "Switch As Is" Conversion Charge - Disconnect - Add'l	UNCCC	\$0.00	\$13.03	\$12.61	\$0.00	\$0.00	\$0.00	\$0.00	\$0.00	\$0.00
	Local Channel - OC48	USOC									
	Local Channel - OC48 - per Mile	TBA	\$33.22	\$36.67	\$27.25	\$133.84	\$119.40	\$166.59	\$120.02	\$47.57	\$93.50
	Local Channel - OC48 - per Facility Termination	TBA	\$1,713	\$1,944	\$1,598.00	\$2,129	\$2,268	\$1,753	\$1,677	\$1,733	\$1,832
	Local Channel - OC12 interface on OC48 Facility	TBA	\$736.71	\$586.28	\$594.80	\$725.77	\$723.29	\$667.00	\$582.66	\$773.40	\$570.54
	NRC - Ordinarily Combined in GA:										
	NRC - OC48 - Facility Termination - 1st	TBA	NA	NA	\$1,162.00	NA	NA	NA	NA	NA	NA
	NRC - OC48 - Facility Termination - Add'l	TBA	NA	NA	\$413.00	NA	NA	NA	NA	NA	NA
	NRC - OC48 - Interface OC12 on OC48 - 1st	TBA	NA	NA	\$539.36	NA	NA	NA	NA	NA	NA
	NRC - OC48 - Interface OC12 on OC48 - Add'l	TBA	NA	NA	\$317.38	NA	NA	NA	NA	NA	NA
	NRC - OC48 - Facility Termination - Disconnect - 1st	TBA	NA	NA	\$122.31	NA	NA	NA	NA	NA	NA
	NRC - OC48 - Facility Termination - Disconnect - Add'l	TBA	NA	NA	\$119.14	NA	NA	NA	NA	NA	NA
	NRC - OC48 - Interface OC12 on OC48 - Disconnect - 1st	TBA	NA	NA	\$122.31	NA	NA	NA	NA	NA	NA
	NRC - OC48 - Interface OC12 on OC48 - Disconnect - Add'l	TBA	NA	NA	\$119.14	NA	NA	NA	NA	NA	NA
	NRC - Electronic Svc Order, per LSR	SOME C	NA	NA	\$3.50	NA	NA	NA	NA	NA	NA

BELLSOUTH/LEVEL 3 RATES
NETWORK ELEMENTS
AND OTHER SERVICES

		USOC	AL	FL	GA	KY	LA	MS	NC	SC	TN
	NRC - OC48 - Facility Termination-Manual Svc Order vs Electronic-Disconnect-1st	SOMAN	NA	NA	\$37.55	NA	NA	NA	NA	NA	NA
	NRC - OC48 - Facility Termination-Manual Svc Order vs Electronic-Disconnect-Add'l	SOMAN	NA	NA	\$37.55	NA	NA	NA	NA	NA	NA
	NRC - OC48 - Interface - Manual Svc Order vs Electronic-Disconnect-1st	SOMAN	NA	NA	\$37.55	NA	NA	NA	NA	NA	NA
	NRC - OC48 - Interface - Manual Svc Order vs Electronic-Disconnect-Add'l	SOMAN	NA	NA	\$37.55	NA	NA	NA	NA	NA	NA
	NRC - OC-48 - Incremental Charge--Manual Svc Order-1st	SOMAN	NA	NA	\$18.03	NA	NA	NA	NA	NA	NA
	NRC - OC-48 - Incremental Charge--Manual Svc Order-Add'l	SOMAN	NA	NA	\$18.03	NA	NA	NA	NA	NA	NA
	NRC - OC48 - Interface OC12 on OC48 - Incremental Charge--Manual Svc Order-1st	SOMAN	NA	NA	\$18.03	NA	NA	NA	NA	NA	NA
	NRC - OC48 - Interface OC12 on OC48 - Incremental Charge--Manual Svc Order-Add'l	SOMAN	NA	NA	\$18.03	NA	NA	NA	NA	NA	NA
	NRC-All Existing Combination "Switch As Is" Conversion Charge										
	NRC-OC-48 COMBINATION - "Switch As Is" Conversion Charge - 1st	UNCCC	\$54.03	\$11.27	\$58.43	\$54.09	\$54.23	\$54.09	\$54.00	\$54.26	\$54.13
	NRC-OC-48 COMBINATION - "Switch As Is" Conversion Charge - Add'l	UNCCC	\$32.11	\$11.27	\$26.99	\$32.16	\$32.24	\$32.16	\$32.10	\$32.25	\$32.17
	NRC - OC-48 COMBINATION - "Switch As Is" Conversion Charge - Disconnect - 1st	UNCCC	\$0.00	\$13.03	\$12.61	\$0.00	\$0.00	\$0.00	\$0.00	\$0.00	\$0.00
	NRC - OC-48 COMBINATION - "Switch As Is" Conversion Charge - Disconnect - Add'l	UNCCC	\$0.00	\$13.03	\$12.61	\$0.00	\$0.00	\$0.00	\$0.00	\$0.00	\$0.00
	High Capacity Loops:										
	Local Loop - Dedicated - DS3										
	DS3 Local Loop- per mile per month	1L5ND	\$10.85	\$11.97	\$8.90	\$43.69	\$11.26	\$11.40	\$11.40	\$15.53	\$30.53
	DS3 Local Loop- per Facility Termination	UE3PX	\$419.65	\$449.40	\$390.34	\$436.95	\$439.59	\$413.09	\$413.09	\$421.60	\$400.21
	NRC - Ordinarily Combined in GA:										
	NRC - DS3 Local Channel - Facility Termination - 1st	UE3PX	NA	NA	\$761.81	NA	NA	NA	NA	NA	NA
	NRC - DS3 Local Channel - Facility Termination - Add'l	UE3PX	NA	NA	\$545.54	NA	NA	NA	NA	NA	NA
	NRC - Electronic Svc Order, per LSR	SOMEK	NA	NA	\$3.50	NA	NA	NA	NA	NA	NA
	NRC - DS3 Local Channel - Incremental Charge--Manual Svc Order - 1st	SOMAN	NA	NA	\$37.55	NA	NA	NA	NA	NA	NA
	NRC - DS3 Local Channel - Incremental Charge--Manual Svc Order - Add'l	SOMAN	NA	NA	\$37.55	NA	NA	NA	NA	NA	NA
	NRC - DS3 Local Channel - Incremental Charge--Manual Svc Order - Disconnect - 1st	SOMAN	NA	NA	\$18.03	NA	NA	NA	NA	NA	NA
	NRC - DS3 Local Channel - Incremental Charge--Manual Svc Order - Disconnect - Add'l	SOMAN	NA	NA	\$18.03	NA	NA	NA	NA	NA	NA
	NRC-All Existing Combination "Switch As Is" Conversion Charge										
	NRC-DS3 COMBINATION - "Switch As Is" Conversion Charge - 1st	UNCCC	\$54.03	\$11.27	\$58.43	\$54.09	\$54.23	\$54.09	\$54.00	\$54.26	\$54.13
	NRC-DS3 COMBINATION - "Switch As Is" Conversion Charge - Add'l	UNCCC	\$32.11	\$11.27	\$26.99	\$32.16	\$32.24	\$32.16	\$32.10	\$32.25	\$32.17
	NRC - DS3 COMBINATION - "Switch As Is" Conversion Charge - Disconnect - 1st	UNCCC	\$0.00	\$13.03	\$12.61	\$0.00	\$0.00	\$0.00	\$0.00	\$0.00	\$0.00
	NRC - DS3 COMBINATION - "Switch As Is" Conversion Charge - Disconnect - Add'l	UNCCC	\$0.00	\$13.03	\$12.61	\$0.00	\$0.00	\$0.00	\$0.00	\$0.00	\$0.00
	Local Loop - Dedicated - STS-1										
	STS-1 Local Loop - per mile	1L5ND	\$10.85	\$11.97	\$8.90	\$43.69	\$11.29	\$54.39	\$11.40	\$15.53	\$30.53
	STS-1 Local Loop- per Facility Termination	UDLS1	\$434.31	\$449.40	\$390.34	\$436.95	\$454.28	\$427.81	\$428.93	\$431.32	\$400.21
	NRC - Ordinarily Combined in GA:										
	NRC - STS-1 Local Loop - Facility Termination - 1st	UDLS1	NA	NA	\$761.81	NA	NA	NA	NA	NA	NA
	NRC - STS-1 Local Loop - Facility Termination - Add'l	UDLS1	NA	NA	\$545.54	NA	NA	NA	NA	NA	NA
	NRC - Electronic Svc Order, per LSR	SOMEK	NA	NA	\$3.50	NA	NA	NA	NA	NA	NA

BELLSOUTH/LEVEL 3 RATES
NETWORK ELEMENTS
AND OTHER SERVICES

		USOC	AL	FL	GA	KY	LA	MS	NC	SC	TN
	NRC - STS-1 Local Loop - Incremental Charge--Manual Svc Order - 1st	SOMAN	NA	NA	\$37.55	NA	NA	NA	NA	NA	NA
	NRC - STS-1 Local Loop - Incremental Charge--Manual Svc Order - Add'l	SOMAN	NA	NA	\$37.55	NA	NA	NA	NA	NA	NA
	NRC - STS-1 Local Loop - Incremental Charge--Manual Svc Order - Disconnect - 1st	SOMAN	NA	NA	\$18.03	NA	NA	NA	NA	NA	NA
	NRC - STS-1 Local Loop - Incremental Charge--Manual Svc Order - Disconnect - Add'l	SOMAN	NA	NA	\$18.03	NA	NA	NA	NA	NA	NA
	NRC-All Existing Combination "Switch As Is" Conversion Charge										
	NRC-ST5-1 COMBINATION - "Switch As Is" Conversion Charge - 1st	UNCCC	\$54.03	\$11.27	\$58.43	\$54.09	\$54.23	\$54.09	\$54.00	\$54.26	\$54.13
	NRC-ST5-1 COMBINATION - "Switch As Is" Conversion Charge - Add'l	UNCCC	\$32.11	\$11.27	\$26.99	\$32.16	\$32.24	\$32.16	\$32.10	\$32.25	\$32.17
	NRC - STS-1 COMBINATION - "Switch As Is" Conversion Charge - Disconnect - 1st	UNCCC	\$0.00	\$13.03	\$12.61	\$0.00	\$0.00	\$0.00	\$0.00	\$0.00	\$0.00
	NRC - STS-1 COMBINATION - "Switch As Is" Conversion Charge - Disconnect - Add'l	UNCCC	\$0.00	\$13.03	\$12.61	\$0.00	\$0.00	\$0.00	\$0.00	\$0.00	\$0.00
	Local Loop - OC3										
	Local Loop - OC3 - per Mile	TBA	\$8.23	\$9.08	\$6.75	\$33.15	\$29.58	\$41.27	\$24.69	\$11.78	\$23.16
	Local Loop - OC3 - per Facility Termination	TBA	\$691.33	\$651.40	\$630.21	\$713.29	\$753.65	\$689.68	\$611.36	\$701.71	\$620.20
	NRC - Ordinarily Combined in GA:										
	NRC - OC3 - Facility Termination - 1st	TBA	NA	NA	\$947.69	NA	NA	NA	NA	NA	NA
	NRC - OC3 - Facility Termination - Add'l	TBA	NA	NA	\$413.00	NA	NA	NA	NA	NA	NA
	NRC - OC3 - Facility Termination - Disconnect - 1st	TBA	NA	NA	\$122.31	NA	NA	NA	NA	NA	NA
	NRC - OC3 - Facility Termination - Disconnect - Add'l	TBA	NA	NA	\$119.14	NA	NA	NA	NA	NA	NA
	NRC - Electronic Svc Order, per LSR	SOMECE	NA	NA	\$3.50	NA	NA	NA	NA	NA	NA
	NRC - OC3 - Incremental Charge--Manual Svc Order - 1st	SOMAN	NA	NA	\$37.55	NA	NA	NA	NA	NA	NA
	NRC - OC3 - Incremental Charge--Manual Svc Order - Add'l	SOMAN	NA	NA	\$37.55	NA	NA	NA	NA	NA	NA
	NRC - OC3 -Incremental Cost - Manual Svc. Order vs. Elect-Disconnect-1st	SOMAN	NA	NA	\$18.03	NA	NA	NA	NA	NA	NA
	NRC - OC3 -Incremental Cost - Manual Svc. Order vs. Elect-Disconnect-Add'l	SOMAN	NA	NA	\$18.03	NA	NA	NA	NA	NA	NA
	NRC-All Existing Combination "Switch As Is" Conversion Charge										
	NRC-OC-3 COMBINATION - "Switch As Is" Conversion Charge - 1st	UNCCC	\$54.03	\$11.27	\$58.43	\$54.09	\$54.23	\$54.09	\$54.00	\$54.26	\$54.13
	NRC-OC-3 COMBINATION - "Switch As Is" Conversion Charge - Add'l	UNCCC	\$32.11	\$11.27	\$26.99	\$32.16	\$32.24	\$32.16	\$32.10	\$32.25	\$32.17
	NRC - OC-3 COMBINATION - "Switch As Is" Conversion Charge - Disconnect - 1st	UNCCC	\$0.00	\$13.03	\$12.61	\$0.00	\$0.00	\$0.00	\$0.00	\$0.00	\$0.00
	NRC - OC-3 COMBINATION - "Switch As Is" Conversion Charge - Disconnect - Add'l	UNCCC	\$0.00	\$13.03	\$12.61	\$0.00	\$0.00	\$0.00	\$0.00	\$0.00	\$0.00
	Local Loop - OC12										
	Local Loop - OC12 - per Mile	TBA	\$10.13	\$11.18	\$8.31	\$40.80	\$36.40	\$50.79	\$30.38	\$14.50	\$28.51
	Local Loop - OC12 - per Facility Termination	TBA	\$2,557	\$2,068	\$2,109.00	\$2,457	\$2,571	\$2,371	\$2,122	\$2,663	\$2,079
	NRC - Ordinarily Combined in GA:										
	NRC - OC12 - Facility Termination - 1st	TBA	NA	NA	\$1,162.00	NA	NA	NA	NA	NA	NA
	NRC - OC12 - Facility Termination - Add'l	TBA	NA	NA	\$413.00	NA	NA	NA	NA	NA	NA
	NRC - OC12 - Facility Termination - Disconnect - 1st	TBA	NA	NA	\$122.31	NA	NA	NA	NA	NA	NA
	NRC - OC12 - Facility Termination - Disconnect - Add'l	TBA	NA	NA	\$119.14	NA	NA	NA	NA	NA	NA
	NRC - Electronic Svc Order, per LSR	SOMECE	NA	NA	\$3.50	NA	NA	NA	NA	NA	NA
	NRC - OC12 - Incremental Charge - Manual Svc Order - 1st	SOMAN	NA	NA	\$37.55	NA	NA	NA	NA	NA	NA
	NRC - OC12 - Incremental Charge - Manual Svc Order - Add'l	SOMAN	NA	NA	\$37.55	NA	NA	NA	NA	NA	NA
	NRC - OC12 - Incremental Cost-Manual Svc. Order vs. Elect-Disconnect-1st	SOMAN	NA	NA	\$18.03	NA	NA	NA	NA	NA	NA
	NRC - OC12 - Incremental Cost-Manual Svc. Order vs. Elect-Disconnect-Add'l	SOMAN	NA	NA	\$18.03	NA	NA	NA	NA	NA	NA

BELLSOUTH/LEVEL 3 RATES
NETWORK ELEMENTS
AND OTHER SERVICES

	USOC	AL	FL	GA	KY	LA	MS	NC	SC	TN
NRC-All Existing Combination "Switch As Is" Conversion Charge										
NRC-OC-12 COMBINATION - "Switch As Is" Conversion Charge - 1st	UNCCC	\$54.03	\$11.27	\$58.43	\$54.09	\$54.23	\$54.09	\$54.00	\$54.26	\$54.13
NRC-OC-12 COMBINATION - "Switch As Is" Conversion Charge - Add'l	UNCCC	\$32.11	\$11.27	\$26.99	\$32.16	\$32.24	\$32.16	\$32.10	\$32.25	\$32.17
NRC- OC-12 COMBINATION - "Switch As Is" Conversion Charge - Disconnect - 1st	UNCCC	\$0.00	\$13.03	\$12.61	\$0.00	\$0.00	\$0.00	\$0.00	\$0.00	\$0.00
NRC- OC-12 COMBINATION - "Switch As Is" Conversion Charge - Disconnect - Add'l	UNCCC	\$0.00	\$13.03	\$12.61	\$0.00	\$0.00	\$0.00	\$0.00	\$0.00	\$0.00
Local Loop - OC48										
Local Loop - OC48 - per Mile	TBA	\$33.22	\$36.67	\$27.25	\$133.84	\$119.40	\$166.59	\$120.02	\$47.57	\$93.50
Local Loop - OC48 - per Facility Termination	TBA	\$1,713	\$1,699	\$1,598.00	\$2,129	\$2,268	\$1,753	\$1,677	\$1,733	\$1,832
Local Loop - OC12 interface on OC48 Facility	TBA	\$736.71	\$592.09	\$594.80	\$725.77	\$723.29	\$667.00	\$582.66	\$773.40	\$570.54
NRC - Ordinarily Combined in GA:										
NRC - OC48 - Facility Termination - 1st	TBA	NA	NA	\$1,162.00	NA	NA	NA	NA	NA	NA
NRC - OC48 - Facility Termination - Add'l	TBA	NA	NA	\$413.00	NA	NA	NA	NA	NA	NA
NRC - OC48 - Interface OC12 on OC48 - 1st	TBA	NA	NA	\$539.36	NA	NA	NA	NA	NA	NA
NRC - OC48 - Interface OC12 on OC48 - Add'l	TBA	NA	NA	\$317.38	NA	NA	NA	NA	NA	NA
NRC - OC48 - Facility Termination - Disconnect - 1st	TBA	NA	NA	\$122.31	NA	NA	NA	NA	NA	NA
NRC - OC48 - Facility Termination - Disconnect - Add'l	TBA	NA	NA	\$119.14	NA	NA	NA	NA	NA	NA
NRC - OC48- Interface OC12 on OC48 - Disconnect - 1st	TBA	NA	NA	\$122.31	NA	NA	NA	NA	NA	NA
NRC - OC48 - Interface OC12 on OC48 - Disconnect - Add'l	TBA	NA	NA	\$119.14	NA	NA	NA	NA	NA	NA
NRC - Electronic Svc Order, per LSR	SOMEK	NA	NA	\$3.50	NA	NA	NA	NA	NA	NA
NRC - OC48 - Facility Termination-Manual Svc Order vs Electronic-Disconnect-1st	SOMAN	NA	NA	\$37.55	NA	NA	NA	NA	NA	NA
NRC - OC48 - Facility Termination-Manual Svc Order vs Electronic-Disconnect-Add'l	SOMAN	NA	NA	\$37.55	NA	NA	NA	NA	NA	NA
NRC - OC48 - Interface - Manual Svc Order vs Electronic-Disconnect-1st	SOMAN	NA	NA	\$37.55	NA	NA	NA	NA	NA	NA
NRC - OC48 - Interface - Manual Svc Order vs Electronic-Disconnect-Add'l	SOMAN	NA	NA	\$37.55	NA	NA	NA	NA	NA	NA
NRC - OC-48 - Incremental Charge--Manual Svc Order-1st	SOMAN	NA	NA	\$18.03	NA	NA	NA	NA	NA	NA
NRC - OC-48 - Incremental Charge--Manual Svc Order-Add'l	SOMAN	NA	NA	\$18.03	NA	NA	NA	NA	NA	NA
NRC - OC48 - Interface OC12 on OC48 - Incremental Charge--Manual Svc Order-1st	SOMAN	NA	NA	\$18.03	NA	NA	NA	NA	NA	NA
NRC - OC48 - Interface OC12 on OC48 - Incremental Charge--Manual Svc Order-Add'l	SOMAN	NA	NA	\$18.03	NA	NA	NA	NA	NA	NA
NRC-All Existing Combination "Switch As Is" Conversion Charge										
NRC-OC-48 COMBINATION - "Switch As Is" Conversion Charge - 1st	UNCCC	\$54.03	\$11.27	\$58.43	\$54.09	\$54.23	\$54.09	\$54.00	\$54.26	\$54.13
NRC-OC-48 COMBINATION - "Switch As Is" Conversion Charge - Add'l	UNCCC	\$32.11	\$11.27	\$26.99	\$32.16	\$32.24	\$32.16	\$32.10	\$32.25	\$32.17
NRC- OC-48 COMBINATION - "Switch As Is" Conversion Charge - Disconnect - 1st	UNCCC	\$0.00	\$13.03	\$12.61	\$0.00	\$0.00	\$0.00	\$0.00	\$0.00	\$0.00
NRC- OC-48 COMBINATION - "Switch As Is" Conversion Charge - Disconnect - Add'l	UNCCC	\$0.00	\$13.03	\$12.61	\$0.00	\$0.00	\$0.00	\$0.00	\$0.00	\$0.00
Interoffice Channels:										
Interoffice Channel - Dedicated - 2-wire VG										
Interoffice Channel - Dedicated 2-wire VG - per mile per month	1L5XX	\$0.03	\$0.0100	\$0.02	\$0.03	\$0.04	\$0.03	\$0.03	\$0.04	\$0.02
Interoffice Channel - Dedicated 2-wire VG - Facility Termination per month	U1TV2	\$18.49	\$26.72	\$17.07	\$27.66	\$19.10	\$21.33	\$18.01	\$21.42	\$18.33
NRC - Ordinarily Combined in GA:										
NRC - 2-wire VG Interoffice Channel - Facility Termination - 1st	U1TV2	NA	NA	\$79.61	NA	NA	NA	NA	NA	NA
NRC - 2-wire VG Interoffice Channel - Facility Termination - Add'l	U1TV2	NA	NA	\$36.08	NA	NA	NA	NA	NA	NA

BELLSOUTH/LEVEL 3 RATES
NETWORK ELEMENTS
AND OTHER SERVICES

		USOC	AL	FL	GA	KY	LA	MS	NC	SC	TN
	NRC - Electronic Svc Order, per LSR	SOMECC	NA	NA	\$3.50	NA	NA	NA	NA	NA	NA
	NRC - 2-wire VG Interoffice Channel - Incremental Charge--Manual Svc Order - 1st	SOMAN	NA	NA	\$18.94	NA	NA	NA	NA	NA	NA
	NRC - 2-wire VG Interoffice Channel - Incremental Charge--Manual Svc Order - Add'l	SOMAN	NA	NA	\$18.94	NA	NA	NA	NA	NA	NA
	NRC - 2-wire VG Interoffice Channel - Incremental Charge--Manual Svc Order - Disconnect - 1st	SOMAN	NA	NA	NA	NA	NA	NA	NA	NA	NA
	NRC - 2-wire VG Interoffice Channel - Incremental Charge--Manual Svc Order - Disconnect - Add'l	SOMAN	NA	NA	NA	NA	NA	NA	NA	NA	NA
	NRC-All Existing Combination "Switch As Is" Conversion Charge										
	NRC-2/4-WIRE VG COMBINATION - "Switch As Is" Conversion Charge - 1st	UNCCC	\$54.03	\$11.27	\$58.43	\$54.09	\$54.23	\$54.09	\$54.00	\$54.26	\$54.13
	NRC-2/4-WIRE VG COMBINATION - "Switch As Is" Conversion Charge - Add'l	UNCCC	\$32.11	\$11.27	\$26.99	\$32.16	\$32.24	\$32.16	\$32.10	\$32.25	\$32.17
	NRC- 2/4-WIRE VG COMBINATION - "Switch As Is" Conversion Charge - Disconnect - 1st	UNCCC	\$0.00	\$13.03	\$12.61	\$0.00	\$0.00	\$0.00	\$0.00	\$0.00	\$0.00
	NRC- 2/4-WIRE VG COMBINATION - "Switch As Is" Conversion Charge - Disconnect - Add'l	UNCCC	\$0.00	\$13.03	\$12.61	\$0.00	\$0.00	\$0.00	\$0.00	\$0.00	\$0.00
	Interoffice Channel - Dedicated - 4-wire VG										
	Interoffice Channel - Dedicated 4-wire VG - per mile per month	1L5XX	NA	\$0.0100	NA	NA	NA	NA	NA	NA	NA
	Interoffice Channel - Dedicated 4-wire VG - Facility Termination per month	U1TV4	NA	\$23.82	NA	NA	NA	NA	NA	NA	NA
	NRC - Ordinarily Combined in GA:										
	NRC - 4-wire VG Interoffice Channel - Facility Termination - 1st	U1TV4	NA	NA	NA	NA	NA	NA	NA	NA	NA
	NRC - 4-wire VG Interoffice Channel - Facility Termination - Add'l	U1TV4	NA	NA	NA	NA	NA	NA	NA	NA	NA
	NRC - Electronic Svc Order, per LSR	SOMECC	NA	NA	NA	NA	NA	NA	NA	NA	NA
	NRC - 4-wire VG Interoffice Channel - Incremental Charge--Manual Svc Order - 1st	SOMAN	NA	NA	NA	NA	NA	NA	NA	NA	NA
	NRC - 4-wire VG Interoffice Channel - Incremental Charge--Manual Svc Order - Add'l	SOMAN	NA	NA	NA	NA	NA	NA	NA	NA	NA
	NRC - 4-wire VG Interoffice Channel - Incremental Charge--Manual Svc Order - Disconnect - 1st	SOMAN	NA	NA	NA	NA	NA	NA	NA	NA	NA
	NRC - 4-wire VG Interoffice Channel - Incremental Charge--Manual Svc Order - Disconnect - Add'l	SOMAN	NA	NA	NA	NA	NA	NA	NA	NA	NA
	NRC-All Existing Combination "Switch As Is" Conversion Charge										
	NRC-2/4-WIRE VG COMBINATION - "Switch As Is" Conversion Charge - 1st	UNCCC	\$54.03	\$11.27	\$58.43	\$54.09	\$54.23	\$54.09	\$54.00	\$54.26	\$54.13
	NRC-2/4-WIRE VG COMBINATION - "Switch As Is" Conversion Charge - Add'l	UNCCC	\$32.11	\$11.27	\$26.99	\$32.16	\$32.24	\$32.16	\$32.10	\$32.25	\$32.17
	NRC- 2/4-WIRE VG COMBINATION - "Switch As Is" Conversion Charge - Disconnect - 1st	UNCCC	\$0.00	\$13.03	\$12.61	\$0.00	\$0.00	\$0.00	\$0.00	\$0.00	\$0.00
	NRC- 2/4-WIRE VG COMBINATION - "Switch As Is" Conversion Charge - Disconnect - Add'l	UNCCC	\$0.00	\$13.03	\$12.61	\$0.00	\$0.00	\$0.00	\$0.00	\$0.00	\$0.00
	Interoffice Channel - Dedicated - DS0 - 56kbps										
	Interoffice Channel - Dedicated - DS0 - 56kbps - per mile per month	1L5XX	\$0.03	\$0.0100	\$0.02	\$0.03	\$0.04	\$0.03	\$0.03	\$0.04	\$0.17
	Interoffice Channel - Dedicated - DS0 - 56 kbps - Facility Termination per month	U1TD5	\$17.81	\$19.46	\$16.45	\$26.95	\$18.37	\$20.64	\$17.40	\$20.71	\$17.74
	NRC - Ordinarily Combined in GA:										
	NRC - 4-wire 56kbps Interoffice Channel - Facility Termination - 1st	U1TD5	NA	NA	\$79.61	NA	NA	NA	NA	NA	NA
	NRC - 4-wire 56 kbps Interoffice Channel - Facility Termination - Add'l	U1TD5	NA	NA	\$36.08	NA	NA	NA	NA	NA	NA
	NRC - Electronic Svc Order, per LSR	SOMECC	NA	NA	\$3.50	NA	NA	NA	NA	NA	NA

BELLSOUTH/LEVEL 3 RATES
NETWORK ELEMENTS
AND OTHER SERVICES

		USOC	AL	FL	GA	KY	LA	MS	NC	SC	TN
	NRC - 4-wire 56 kbps Interoffice Channel - Incremental Charge--Manual Svc Order - 1st	SOMAN	NA	NA	\$18.94	NA	NA	NA	NA	NA	NA
	NRC - 4-wire 56 kbps Interoffice Channel - Incremental Charge--Manual Svc Order - Add'l	SOMAN	NA	NA	\$18.94	NA	NA	NA	NA	NA	NA
	NRC - 4-wire 56 kbps Interoffice Channel - Incremental Charge--Manual Svc Order - Disconnect - 1st	SOMAN	NA	NA	NA	NA	NA	NA	NA	NA	NA
	NRC - 4-wire 56 kbps Interoffice Channel - Incremental Charge--Manual Svc Order - Disconnect - Add'l	SOMAN	NA	NA	NA	NA	NA	NA	NA	NA	NA
	NRC-All Existing Combination "Switch As Is" Conversion Charge										
	NRC-2/4-WIRE VG COMBINATION - "Switch As Is" Conversion Charge - 1st	UNCCC	\$54.03	\$11.27	\$58.43	\$54.09	\$54.23	\$54.09	\$54.00	\$54.26	\$54.13
	NRC-2/4-WIRE VG COMBINATION - "Switch As Is" Conversion Charge - Add'l	UNCCC	\$32.11	\$11.27	\$26.99	\$32.16	\$32.24	\$32.16	\$32.10	\$32.25	\$32.17
	NRC- 2/4-WIRE VG COMBINATION - "Switch As Is" Conversion Charge - Disconnect - 1st	UNCCC	\$0.00	\$13.03	\$12.61	\$0.00	\$0.00	\$0.00	\$0.00	\$0.00	\$0.00
	NRC- 2/4-WIRE VG COMBINATION - "Switch As Is" Conversion Charge - Disconnect - Add'l	UNCCC	\$0.00	\$13.03	\$12.61	\$0.00	\$0.00	\$0.00	\$0.00	\$0.00	\$0.00
	Interoffice Channel - Dedicated - DS0 - 64kbps	USOC	AL	FL	GA	KY	LA	MS	NC	SC	TN
	Interoffice Channel - Dedicated - DS0 - 64kbps - per mile per month	1L5XX	\$0.03	\$0.0100	\$0.02	\$0.03	\$0.04	\$0.03	\$0.03	\$0.04	\$0.17
	Interoffice Channel - Dedicated - DS0 - 64 kbps - Facility Termination per month	U1TD6	\$17.81	\$19.46	\$16.45	\$26.95	\$18.37	\$20.64	\$17.40	\$20.71	\$17.74
	NRC - Ordinarily Combined in GA:										
	NRC - 4-wire 64kbps Interoffice Channel - Facility Termination - 1st	U1TD6	NA	NA	\$79.61	NA	NA	NA	NA	NA	NA
	NRC - 4-wire 64 kbps Interoffice Channel - Facility Termination - Add'l	U1TD6	NA	NA	\$36.08	NA	NA	NA	NA	NA	NA
	NRC - Electronic Svc Order, per LSR	SOMEK	NA	NA	\$3.50	NA	NA	NA	NA	NA	NA
	NRC - 4-wire 64 kbps Interoffice Channel - Incremental Charge--Manual Svc Order - 1st	SOMAN	NA	NA	\$18.94	NA	NA	NA	NA	NA	NA
	NRC - 4-wire 64 kbps Interoffice Channel - Incremental Charge--Manual Svc Order - Add'l	SOMAN	NA	NA	\$18.94	NA	NA	NA	NA	NA	NA
	NRC - 4-wire 64 kbps Interoffice Channel - Incremental Charge--Manual Svc Order - Disconnect - 1st	SOMAN	NA	NA	NA	NA	NA	NA	NA	NA	NA
	NRC - 4-wire 64 kbps Interoffice Channel - Incremental Charge--Manual Svc Order - Disconnect - Add'l	SOMAN	NA	NA	NA	NA	NA	NA	NA	NA	NA
	NRC-All Existing Combination "Switch As Is" Conversion Charge										
	NRC-2/4-WIRE VG COMBINATION - "Switch As Is" Conversion Charge - 1st	UNCCC	\$54.03	\$11.27	\$58.43	\$54.09	\$54.23	\$54.09	\$54.00	\$54.26	\$54.13
	NRC-2/4-WIRE VG COMBINATION - "Switch As Is" Conversion Charge - Add'l	UNCCC	\$32.11	\$11.27	\$26.99	\$32.16	\$32.24	\$32.16	\$32.10	\$32.25	\$32.17
	NRC- 2/4-WIRE VG COMBINATION - "Switch As Is" Conversion Charge - Disconnect - 1st	UNCCC	\$0.00	\$13.03	\$12.61	\$0.00	\$0.00	\$0.00	\$0.00	\$0.00	\$0.00
	NRC- 2/4-WIRE VG COMBINATION - "Switch As Is" Conversion Charge - Disconnect - Add'l	UNCCC	\$0.00	\$13.03	\$12.61	\$0.00	\$0.00	\$0.00	\$0.00	\$0.00	\$0.00
	Interoffice Channel - Dedicated - DS1										
	Interoffice Channel - Dedicated - DS1 - per mile per month	1L5XX	\$0.69	\$0.2035	\$0.31	\$0.45	\$0.78	\$0.66	\$0.58	\$0.76	\$0.35
	Interoffice Channel - Dedicated - DS1 - Facility Termination per month	U1TF1	\$79.69	\$93.31	\$63.39	\$55.05	\$93.40	\$74.40	\$71.29	\$94.98	\$75.83
	NRC - Ordinarily Combined in GA:										
	NRC - DS1 Interoffice Channel - Facility Termination - 1st	U1TF1	NA	NA	\$162.03	NA	NA	NA	NA	NA	NA
	NRC - DS1 Interoffice Channel - Facility Termination - Add'l	U1TF1	NA	NA	\$107.76	NA	NA	NA	NA	NA	NA
	NRC - Electronic Svc Order, per LSR	SOMEK	NA	NA	\$3.50	NA	NA	NA	NA	NA	NA
	NRC - DS1 Interoffice Channel - Incremental Charge--Manual Svc Order - 1st	SOMAN	NA	NA	\$23.98	NA	NA	NA	NA	NA	NA

BELLSOUTH/LEVEL 3 RATES
NETWORK ELEMENTS
AND OTHER SERVICES

		USOC	AL	FL	GA	KY	LA	MS	NC	SC	TN
	NRC - DS1 Interoffice Channel - Incremental Charge--Manual Svc Order - Add'l	SOMAN	NA	NA	\$17.77	NA	NA	NA	NA	NA	NA
	NRC - DS1 Interoffice Channel - Incremental Charge--Manual Svc Order - Disconnect - 1st	SOMAN	NA	NA	\$15.13	NA	NA	NA	NA	NA	NA
	NRC - DS1 Interoffice Channel - Incremental Charge--Manual Svc Order - Disconnect - Add'l	SOMAN	NA	NA	\$7.02	NA	NA	NA	NA	NA	NA
	NRC-All Existing Combination "Switch As Is" Conversion Charge										
	NRC-DS1 COMBINATION - "Switch As Is" Conversion Charge - 1st	UNCCC	\$54.03	\$11.27	\$58.43	\$54.09	\$54.23	\$54.09	\$54.00	\$54.26	\$54.13
	NRC-DS1 COMBINATION - "Switch As Is" Conversion Charge - Add'l	UNCCC	\$32.11	\$11.27	\$26.99	\$32.16	\$32.24	\$32.16	\$32.10	\$32.25	\$32.17
	NRC- DS1 COMBINATION - "Switch As Is" Conversion Charge - Disconnect - 1st	UNCCC	\$0.00	\$13.03	\$12.61	\$0.00	\$0.00	\$0.00	\$0.00	\$0.00	\$0.00
	NRC- DS1 COMBINATION - "Switch As Is" Conversion Charge - Disconnect - Add'l	UNCCC	\$0.00	\$13.03	\$12.61	\$0.00	\$0.00	\$0.00	\$0.00	\$0.00	\$0.00
	Interoffice Channel - Dedicated - DS3 - per mile per month										
	Interoffice Channel - Dedicated - DS3 - per mile per month	1L5XX	\$4.98	\$4.25	\$6.46	\$12.06	\$16.15	\$13.48	\$12.98	\$19.14	\$6.88
	Interoffice Channel - Dedicated - DS3 - Facility Termination per month	U1TF3	\$898.15	\$1,130	\$717.60	\$1,112.02	\$1,131.09	\$686.84	\$720.38	\$904.49	\$840.61
	NRC - Ordinarily Combined in GA:										
	NRC - DS3 Interoffice Channel - Facility Termination - 1st	U1TF3	NA	NA	\$579.26	NA	NA	NA	NA	NA	NA
	NRC - DS3 Interoffice Channel - Facility Termination - Add'l	U1TF3	NA	NA	\$312.99	NA	NA	NA	NA	NA	NA
	NRC - Electronic Svc Order, per LSR	SOMEK	NA	NA	\$3.50	NA	NA	NA	NA	NA	NA
	NRC - DS3 Interoffice Channel - Incremental Charge--Manual Svc Order - 1st	SOMAN	NA	NA	\$51.27	NA	NA	NA	NA	NA	NA
	NRC - DS3 Interoffice Channel - Incremental Charge--Manual Svc Order - Add'l	SOMAN	NA	NA	\$38.87	NA	NA	NA	NA	NA	NA
	NRC - DS3 Interoffice Channel - Incremental Charge--Manual Svc Order - Disconnect - 1st	SOMAN	NA	NA	\$30.42	NA	NA	NA	NA	NA	NA
	NRC - DS3 Interoffice Channel - Incremental Charge--Manual Svc Order - Disconnect - Add'l	SOMAN	NA	NA	\$18.76	NA	NA	NA	NA	NA	NA
	NRC-All Existing Combination "Switch As Is" Conversion Charge										
	NRC-DS3 COMBINATION - "Switch As Is" Conversion Charge - 1st	UNCCC	\$54.03	\$11.27	\$58.43	\$54.09	\$54.23	\$54.09	\$54.00	\$54.26	\$54.13
	NRC-DS3 COMBINATION - "Switch As Is" Conversion Charge - Add'l	UNCCC	\$32.11	\$11.27	\$26.99	\$32.16	\$32.24	\$32.16	\$32.10	\$32.25	\$32.17
	NRC- DS3 COMBINATION - "Switch As Is" Conversion Charge - Disconnect - 1st	UNCCC	\$0.00	\$13.03	\$12.61	\$0.00	\$0.00	\$0.00	\$0.00	\$0.00	\$0.00
	NRC- DS3 COMBINATION - "Switch As Is" Conversion Charge - Disconnect - Add'l	UNCCC	\$0.00	\$13.03	\$12.61	\$0.00	\$0.00	\$0.00	\$0.00	\$0.00	\$0.00
	Interoffice Channel - Dedicated - STS-1										
	Interoffice Channel - Dedicated - STS-1 - per mile per month	1L5XX	\$4.98	\$9.32	\$2.72	\$12.06	\$6.78	\$15.02	\$12.98	\$8.13	\$6.88
	Interoffice Channel - Dedicated - STS-1 - Facility Termination per month	U1TFS	\$898.15	\$569.67	\$788.00	\$1,112.02	\$1,025.00	\$744.38	\$720.38	\$967.70	\$840.61
	NRC - Ordinarily Combined in GA:										
	NRC - STS-1 Interoffice Channel - Facility Termination - 1st	U1TFS	NA	NA	\$633.41	NA	NA	NA	NA	NA	NA
	NRC - STS-1 Interoffice Channel - Facility Termination - Add'l	U1TFS	NA	NA	\$569.05	NA	NA	NA	NA	NA	NA
	NRC - Electronic Svc Order, per LSR	SOMEK	NA	NA	\$3.50	NA	NA	NA	NA	NA	NA
	NRC - STS-1 Interoffice Channel - Incremental Charge--Manual Svc Order - 1st	SOMAN	NA	NA	\$37.55	NA	NA	NA	NA	NA	NA
	NRC - STS-1 Interoffice Channel - Incremental Charge--Manual Svc Order - Add'l	SOMAN	NA	NA	\$37.55	NA	NA	NA	NA	NA	NA
	NRC - STS-1 Interoffice Channel - Incremental Charge--Manual Svc Order - Disconnect - 1st	SOMAN	NA	NA	\$18.03	NA	NA	NA	NA	NA	NA
	NRC - STS-1 Interoffice Channel - Incremental Charge--Manual Svc Order - Disconnect - Add'l	SOMAN	NA	NA	\$18.03	NA	NA	NA	NA	NA	NA

BELLSOUTH/LEVEL 3 RATES
NETWORK ELEMENTS
AND OTHER SERVICES

		USOC	AL	FL	GA	KY	LA	MS	NC	SC	TN
	NRC-All Existing Combination "Switch As Is" Conversion Charge										
	NRC-ST5-1 COMBINATION - "Switch As Is" Conversion Charge - 1st	UNCCC	\$54.03	\$11.27	\$58.43	\$54.09	\$54.23	\$54.09	\$54.00	\$54.26	\$54.13
	NRC-ST5-1 COMBINATION - "Switch As Is" Conversion Charge - Add'l	UNCCC	\$32.11	\$11.27	\$26.99	\$32.16	\$32.24	\$32.16	\$32.10	\$32.25	\$32.17
	NRC - ST5-1 COMBINATION - "Switch As Is" Conversion Charge - Disconnect - 1st	UNCCC	\$0.00	\$13.03	\$12.61	\$0.00	\$0.00	\$0.00	\$0.00	\$0.00	\$0.00
	NRC - ST5-1 COMBINATION - "Switch As Is" Conversion Charge - Disconnect - Add'l	UNCCC	\$0.00	\$13.03	\$12.61	\$0.00	\$0.00	\$0.00	\$0.00	\$0.00	\$0.00
	Interoffice Channel - OC3										
	Interoffice Channel - OC3 - per Mile	TBA	\$4.98	\$8.38	\$4.37	\$28.56	\$23.89	\$18.35	\$24.69	\$9.75	\$13.45
	Interoffice Channel - OC3 - per Facility Termination	TBA	\$898.15	\$3,043	\$2,187.00	\$1,493	\$2,990.00	\$1,892.00	\$611.36	\$2,802	\$2,124.00
	NRC - Ordinarily Combined in GA:										
	NRC - OC3 - Facility Termination - 1st	TBA	NA	NA	\$947.69	NA	NA	NA	NA	NA	NA
	NRC - OC3 - Facility Termination - Add'l	TBA	NA	NA	\$413.00	NA	NA	NA	NA	NA	NA
	NRC - OC3 - Facility Termination - Disconnect - 1st	TBA	NA	NA	\$122.31	NA	NA	NA	NA	NA	NA
	NRC - OC3 - Facility Termination - Disconnect - Add'l	TBA	NA	NA	\$119.14	NA	NA	NA	NA	NA	NA
	NRC - Electronic Svc Order, per LSR	SOMEK	NA	NA	\$3.50	NA	NA	NA	NA	NA	NA
	NRC - OC3 - Incremental Charge--Manual Svc Order - 1st	SOMAN	NA	NA	\$37.55	NA	NA	NA	NA	NA	NA
	NRC - OC3 - Incremental Charge--Manual Svc Order - Add'l	SOMAN	NA	NA	\$37.55	NA	NA	NA	NA	NA	NA
	NRC - OC3 -Incremental Cost - Manual Svc. Order vs. Elect-Disconnect-1st	SOMAN	NA	NA	\$18.03	NA	NA	NA	NA	NA	NA
	NRC - OC3 -Incremental Cost - Manual Svc. Order vs. Elect-Disconnect-Add'l	SOMAN	NA	NA	\$18.03	NA	NA	NA	NA	NA	NA
	NRC-All Existing Combination "Switch As Is" Conversion Charge										
	NRC-OC-3 COMBINATION - "Switch As Is" Conversion Charge - 1st	UNCCC	\$54.03	\$11.27	\$58.43	\$54.09	\$54.23	\$54.09	\$54.00	\$54.26	\$54.13
	NRC-OC-3 COMBINATION - "Switch As Is" Conversion Charge - Add'l	UNCCC	\$32.11	\$11.27	\$26.99	\$32.16	\$32.24	\$32.16	\$32.10	\$32.25	\$32.17
	NRC - OC-3 COMBINATION - "Switch As Is" Conversion Charge - Disconnect - 1st	UNCCC	\$0.00	\$13.03	\$12.61	\$0.00	\$0.00	\$0.00	\$0.00	\$0.00	\$0.00
	NRC - OC-3 COMBINATION - "Switch As Is" Conversion Charge - Disconnect - Add'l	UNCCC	\$0.00	\$13.03	\$12.61	\$0.00	\$0.00	\$0.00	\$0.00	\$0.00	\$0.00
	Interoffice Channel - OC12										
	Interoffice Channel - OC12 - per Mile	TBA	\$19.26	\$26.91	\$15.05	\$84.88	\$74.44	\$60.42	\$30.38	\$32.52	\$49.80
	Interoffice Channel - OC12 - per Facility Termination	TBA	\$9,763	\$11,685	\$8,202.00	\$12,344	\$11,517.00	\$7,182.00	\$2,122	\$11,132	\$8,015.00
	NRC - Ordinarily Combined in GA:										
	NRC - OC12 - Facility Termination - 1st	TBA	NA	NA	\$1,034.00	NA	NA	NA	NA	NA	NA
	NRC - OC12 - Facility Termination - Add'l	TBA	NA	NA	\$317.38	NA	NA	NA	NA	NA	NA
	NRC - OC12 - Facility Termination - Disconnect - 1st	TBA	NA	NA	\$122.31	NA	NA	NA	NA	NA	NA
	NRC - OC12 - Facility Termination - Disconnect - Add'l	TBA	NA	NA	\$119.14	NA	NA	NA	NA	NA	NA
	NRC - Electronic Svc Order, per LSR	SOMEK	NA	NA	\$3.50	NA	NA	NA	NA	NA	NA
	NRC -OC12 - Incremental Charge - Manual Svc Order - 1st	SOMAN	NA	NA	\$37.55	NA	NA	NA	NA	NA	NA
	NRC - OC12 - Incremental Charge - Manual Svc Order - Add'l	SOMAN	NA	NA	\$37.55	NA	NA	NA	NA	NA	NA
	NRC - OC12 - Incremental Cost-Manual Svc. Order vs. Elect-Disconnect-1st	SOMAN	NA	NA	\$18.03	NA	NA	NA	NA	NA	NA
	NRC - OC12 - Incremental Cost-Manual Svc. Order vs. Elect-Disconnect-Add'l	SOMAN	NA	NA	\$18.03	NA	NA	NA	NA	NA	NA
	NRC-All Existing Combination "Switch As Is" Conversion Charge										
	NRC-OC-12 COMBINATION - "Switch As Is" Conversion Charge - 1st	UNCCC	\$54.03	\$11.27	\$58.43	\$54.09	\$54.23	\$54.09	\$54.00	\$54.26	\$54.13
	NRC-OC-12 COMBINATION - "Switch As Is" Conversion Charge - Add'l	UNCCC	\$32.11	\$11.27	\$26.99	\$32.16	\$32.24	\$32.16	\$32.10	\$32.25	\$32.17
	NRC - OC-12 COMBINATION - "Switch As Is" Conversion Charge - Disconnect - 1st	UNCCC	\$0.00	\$13.03	\$12.61	\$0.00	\$0.00	\$0.00	\$0.00	\$0.00	\$0.00

BELLSOUTH/LEVEL 3 RATES
NETWORK ELEMENTS
AND OTHER SERVICES

		USOC	AL	FL	GA	KY	LA	MS	NC	SC	TN
	NRC - OC-12 COMBINATION - "Switch As Is" Conversion Charge - Disconnect - Add'l	UNCCC	\$0.00	\$13.03	\$12.61	\$0.00	\$0.00	\$0.00	\$0.00	\$0.00	\$0.00
	Interoffice Channel - OC48										
	Interoffice Channel - OC48 - per Mile	TBA	\$30.65	\$34.66	\$25.70	\$138.02	\$128.59	\$102.43	\$120.02	\$45.92	\$106.55
	Interoffice Channel - OC48 - per Facility Termination	TBA	\$11,691	\$12,554	\$11,134.00	\$16,017.00	\$14,950.00	\$11,480.00	\$1,677	\$967.58	\$11,632.00
	Interoffice Channel - OC12 interface on OC48 Facility	TBA	\$1,424	\$1,208	\$1,137.00	\$1,497.00	\$1,451.00	\$1,351.00	\$582.66	\$1,561	\$1,170.00
	NRC - Ordinarily Combined in GA:										
	NRC - OC48 - Facility Termination - 1st	TBA	NA	NA	\$1,034.00	NA	NA	NA	NA	NA	NA
	NRC - OC48 - Facility Termination - Add'l	TBA	NA	NA	\$317.38	NA	NA	NA	NA	NA	NA
	NRC - OC48 - Interface OC12 on OC48 - 1st	TBA	NA	NA	\$539.36	NA	NA	NA	NA	NA	NA
	NRC - OC48 - Interface OC12 on OC48 - Add'l	TBA	NA	NA	\$317.38	NA	NA	NA	NA	NA	NA
	NRC - OC48 - Facility Termination - Disconnect - 1st	TBA	NA	NA	\$122.31	NA	NA	NA	NA	NA	NA
	NRC - OC48 - Facility Termination - Disconnect - Add'l	TBA	NA	NA	\$119.14	NA	NA	NA	NA	NA	NA
	NRC - OC48 - Interface OC12 on OC48 - Disconnect - 1st	TBA	NA	NA	\$122.31	NA	NA	NA	NA	NA	NA
	NRC - OC48 - Interface OC12 on OC48 - Disconnect - Add'l	TBA	NA	NA	\$37.55	NA	NA	NA	NA	NA	NA
	NRC - Electronic Svc Order, per LSR	SOMEK	NA	NA	\$3.50	NA	NA	NA	NA	NA	NA
	NRC - OC48 - Facility Termination-Manual Svc Order vs Electronic-Disconnect-1st	SOMAN	NA	NA	\$37.55	NA	NA	NA	NA	NA	NA
	NRC - OC48 - Facility Termination-Manual Svc Order vs Electronic-Disconnect-Add'l	SOMAN	NA	NA	\$37.55	NA	NA	NA	NA	NA	NA
	NRC - OC48 - Interface - Manual Svc Order vs Electronic-Disconnect-1st	SOMAN	NA	NA	\$37.55	NA	NA	NA	NA	NA	NA
	NRC - OC48 - Interface - Manual Svc Order vs Electronic-Disconnect-Add'l	SOMAN	NA	NA	\$18.03	NA	NA	NA	NA	NA	NA
	NRC - OC-48 - Incremental Charge--Manual Svc Order-1st	SOMAN	NA	NA	\$18.03	NA	NA	NA	NA	NA	NA
	NRC - OC-48 - Incremental Charge--Manual Svc Order-Add'l	SOMAN	NA	NA	\$18.03	NA	NA	NA	NA	NA	NA
	NRC - OC48 - Interface OC12 on OC48 - Incremental Charge--Manual Svc Order-1st	SOMAN	NA	NA	\$18.03	NA	NA	NA	NA	NA	NA
	NRC - OC48 - Interface OC12 on OC48 - Incremental Charge--Manual Svc Order-Add'l	SOMAN	NA	NA	\$18.03	NA	NA	NA	NA	NA	NA
	NRC-All Existing Combination "Switch As Is" Conversion Charge										
	NRC-OC-48 COMBINATION - "Switch As Is" Conversion Charge - 1st	UNCCC	\$54.03	\$11.27	\$58.43	\$54.09	\$54.23	\$54.09	\$54.00	\$54.26	\$54.13
	NRC-OC-48 COMBINATION - "Switch As Is" Conversion Charge - Add'l	UNCCC	\$32.11	\$11.27	\$26.99	\$32.16	\$32.24	\$32.16	\$32.10	\$32.25	\$32.17
	NRC - OC-48 COMBINATION - "Switch As Is" Conversion Charge - Disconnect - 1st	UNCCC	\$0.00	\$13.03	\$12.61	\$0.00	\$0.00	\$0.00	\$0.00	\$0.00	\$0.00
	NRC - OC-48 COMBINATION - "Switch As Is" Conversion Charge - Disconnect - Add'l	UNCCC	\$0.00	\$13.03	\$12.61	\$0.00	\$0.00	\$0.00	\$0.00	\$0.00	\$0.00
	Channelization:										
	DS3 Channelization										
	DS3 Channelized System per month	MQ3	\$225.36	\$222.61	\$202.91	\$236.32	\$244.37	\$229.30	\$236.35	\$200.01	\$225.59
	DS3 Interface per month (DS1 COCI)	UC1D1	\$17.22	\$14.51	\$0.67	\$8.52	\$15.49	\$5.58	\$16.29	\$11.99	\$3.91
	NRC - Ordinarily Combined in GA:										
	NRC - DS3 Channelization - 1st	MQ3	NA	NA	\$248.39	NA	NA	NA	NA	NA	NA
	NRC - DS3 Channelization - Add'l	MQ3	NA	NA	\$134.21	NA	NA	NA	NA	NA	NA
	NRC - Channel Activation - 1st	UC1D1	NA	NA	\$12.15	NA	NA	NA	NA	NA	NA
	NRC - Channel Activation - Add'l	UC1D1	NA	NA	\$8.76	NA	NA	NA	NA	NA	NA
	NRC - Electronic Svc Order, per LSR	SOMEK	NA	NA	\$3.50	NA	NA	NA	NA	NA	NA
	NRC - DS3 Channelization - Incremental Charge--Manual Svc Order - 1st	SOMAN	NA	NA	\$14.91	NA	NA	NA	NA	NA	NA
	NRC - DS3 Channelization - Incremental Charge--Manual Svc Order - Add'l	SOMAN	NA	NA	\$6.63	NA	NA	NA	NA	NA	NA

BELLSOUTH/LEVEL 3 RATES
NETWORK ELEMENTS
AND OTHER SERVICES

		USOC	AL	FL	GA	KY	LA	MS	NC	SC	TN
	NRC - DS3 Channelization - Incremental Charge--Manual Svc Order - Disconnect - 1st	SOMAN	NA	NA	\$10.88	NA	NA	NA	NA	NA	NA
	NRC - DS3 Channelization - Incremental Charge--Manual Svc Order - Disconnect - Add'l	SOMAN	NA	NA	\$0.00	NA	NA	NA	NA	NA	NA
	NRC-All Existing Combination "Switch As Is" Conversion Charge										
	NRC-STS-1 COMBINATION - "Switch As Is" Conversion Charge - 1st	UNCCC	\$54.03	\$11.27	\$58.43	\$54.09	\$54.23	\$54.09	\$54.00	\$54.26	\$54.13
	NRC-STS-1 COMBINATION - "Switch As Is" Conversion Charge - Add'l	UNCCC	\$32.11	\$11.27	\$26.99	\$32.16	\$32.24	\$32.16	\$32.10	\$32.25	\$32.17
	NRC- STS-1 COMBINATION - "Switch As Is" Conversion Charge - Disconnect - 1st	UNCCC	\$0.00	\$13.03	\$12.61	\$0.00	\$0.00	\$0.00	\$0.00	\$0.00	\$0.00
	NRC- STS-1 COMBINATION - "Switch As Is" Conversion Charge - Disconnect - Add'l	UNCCC	\$0.00	\$13.03	\$12.61	\$0.00	\$0.00	\$0.00	\$0.00	\$0.00	\$0.00
	OR										
	NRC-DS3 COMBINATION - "Switch As Is" Conversion Charge - 1st	UNCCC	\$54.03	\$11.27	\$58.43	\$54.09	\$54.23	\$54.09	\$54.00	\$54.26	\$54.13
	NRC-DS3 COMBINATION - "Switch As Is" Conversion Charge - Add'l	UNCCC	\$32.11	\$11.27	\$26.99	\$32.16	\$32.24	\$32.16	\$32.10	\$32.25	\$32.17
	NRC- DS3 COMBINATION - "Switch As Is" Conversion Charge - Disconnect - 1st	UNCCC	\$0.00	\$13.03	\$12.61	\$0.00	\$0.00	\$0.00	\$0.00	\$0.00	\$0.00
	NRC- DS3 COMBINATION - "Switch As Is" Conversion Charge - Disconnect - Add'l	UNCCC	\$0.00	\$13.03	\$12.61	\$0.00	\$0.00	\$0.00	\$0.00	\$0.00	\$0.00
	DS1 Channelization										
	DS1 Channelized System per month	MQ1	\$136.82	\$154.74	\$18.23	\$200.01	\$126.66	\$146.87	\$158.01	\$147.51	\$165.21
	OCU-DP(data) interface card per month (2.4-64kbs)	1D1DD	\$1.66	\$2.22	\$1.06	\$2.94	\$1.94	\$2.86	\$2.03	\$2.34	\$2.46
	VG interface card per month	1D1VG	\$0.86	\$1.46	\$2.67	\$1.40	\$1.06	\$1.45	\$1.28	\$1.47	\$1.25
	2-wire ISDN(BRITE card) per month	UC1CA	\$3.41	\$3.86	\$3.41	\$4.04	\$4.18	\$3.88	\$3.76	\$4.21	\$3.33
	NRC - Ordinarily Combined in GA:										
	NRC - DS1 Channelization - 1st	MQ1	NA	NA	\$131.09	NA	NA	NA	NA	NA	NA
	NRC - DS1 Channelization - Add'l	MQ1	NA	NA	\$87.18	NA	NA	NA	NA	NA	NA
	NRC - Channel Activation VG - 1st	1D1VG	NA	NA	\$12.15	NA	NA	NA	NA	NA	NA
	NRC - Channel Activation VG - Add'l	1D1VG	NA	NA	\$8.76	NA	NA	NA	NA	NA	NA
	NRC - Channel Activation OCU-DP- 1st	1D1DD	NA	NA	\$12.15	NA	NA	NA	NA	NA	NA
	NRC - Channel Activation OCU-DP- Add'l	1D1DD	NA	NA	\$8.76	NA	NA	NA	NA	NA	NA
	NRC - Channel Activation BRITE - 1st	UC1CA	NA	NA	\$12.15	NA	NA	NA	NA	NA	NA
	NRC - Channel Activation BRITE - Add'l	UC1CA	NA	NA	\$8.76	NA	NA	NA	NA	NA	NA
	NRC - Electronic Svc Order, per LSR	SOMEK	NA	NA	\$3.50	NA	NA	NA	NA	NA	NA
	NRC - DS1 Channelization - Incremental Charge--Manual Svc Order - 1st	SOMAN	NA	NA	\$34.00	NA	NA	NA	NA	NA	NA
	NRC - DS1 Channelization - Incremental Charge--Manual Svc Order - Add'l	SOMAN	NA	NA	\$27.79	NA	NA	NA	NA	NA	NA
	NRC - DS1 Channelization - Incremental Charge--Manual Svc Order - Disconnect - 1st	SOMAN	NA	NA	\$20.10	NA	NA	NA	NA	NA	NA
	NRC - DS1 Channelization - Incremental Charge--Manual Svc Order - Disconnect - Add'l	SOMAN	NA	NA	\$11.98	NA	NA	NA	NA	NA	NA
	NRC-All Existing Combination "Switch As Is" Conversion Charge										
	NRC-DS1 COMBINATION - "Switch As Is" Conversion Charge - 1st	UNCCC	\$54.03	\$11.27	\$58.43	\$54.09	\$54.23	\$54.09	\$54.00	\$54.26	\$54.13
	NRC-DS1 COMBINATION - "Switch As Is" Conversion Charge - Add'l	UNCCC	\$32.11	\$11.27	\$26.99	\$32.16	\$32.24	\$32.16	\$32.10	\$32.25	\$32.17
	NRC- DS1 COMBINATION - "Switch As Is" Conversion Charge - Disconnect - 1st	UNCCC	\$0.00	\$13.03	\$12.61	\$0.00	\$0.00	\$0.00	\$0.00	\$0.00	\$0.00
	NRC- DS1 COMBINATION - "Switch As Is" Conversion Charge - Disconnect - Add'l	UNCCC	\$0.00	\$13.03	\$12.61	\$0.00	\$0.00	\$0.00	\$0.00	\$0.00	\$0.00
	Access to DCS - Customer Reconfiguration (FlexServ)										
	DS1 DSC Termination with DS0 Switching	TBD	TBD	\$28.72	\$22.86	TBD	TBD	TBD	TBD	TBD	TBD
	DS1 DSC Termination with DS1 Switching	TBD	TBD	\$12.23	\$8.64	TBD	TBD	TBD	TBD	TBD	TBD

BELLSOUTH/LEVEL 3 RATES
NETWORK ELEMENTS
AND OTHER SERVICES

		USOC	AL	FL	GA	KY	LA	MS	NC	SC	TN
	DS3 DSC Termination with DS1 Switching	TBD	TBD	\$154.31	\$151.85	TBD	TBD	TBD	TBD	TBD	TBD
	NRC - Ordinarily Combined in GA:										
	NRC - Customer Configuration Establishment	TBD	TBD	\$2.97	\$2.91	TBD	TBD	TBD	TBD	TBD	TBD
	NRC - Customer Configuration Establishment - Disconnect	TBD	TBD	\$3.44	\$3.36	TBD	TBD	TBD	TBD	TBD	TBD
	NRC- DS1 DSC Termination with DS0 Switching - 1st	TBD	TBD	\$51.50	\$32.07	TBD	TBD	TBD	TBD	TBD	TBD
	NRC- DS1 DSC Termination with DS0 Switching - Add'l	TBD	TBD	\$39.64	\$31.49	TBD	TBD	TBD	TBD	TBD	TBD
	NRC- DS1 DSC Termination with DS0 Switching - Disconnect - 1st	TBD	TBD	\$31.06	\$20.16	TBD	TBD	TBD	TBD	TBD	TBD
	NRC- DS1 DSC Termination with DS0 Switching - Disconnect - Add'l	TBD	TBD	\$24.98	\$20.16	TBD	TBD	TBD	TBD	TBD	TBD
	NRC- DS1 DSC Termination with NRC- DS1 Switching - 1st	TBD	TBD	\$37.23	\$18.07	TBD	TBD	TBD	TBD	TBD	TBD
	NRC- DS1 DSC Termination with NRC- DS1 Switching - Add'l	TBD	TBD	\$25.36	\$17.49	TBD	TBD	TBD	TBD	TBD	TBD
	NRC- DS1 DSC Termination with NRC- DS1 Switching - Disconnect - 1st	TBD	TBD	\$22.81	\$12.10	TBD	TBD	TBD	TBD	TBD	TBD
	NRC- DS1 DSC Termination with NRC- DS1 Switching - Disconnect - Add'l	TBD	TBD	\$16.73	\$12.10	TBD	TBD	TBD	TBD	TBD	TBD
	NRC- DS3 DSC Termination with NRC- DS1 Switching - 1st	TBD	TBD	\$51.50	\$32.07	TBD	TBD	TBD	TBD	TBD	TBD
	NRC- DS3 DSC Termination with NRC- DS1 Switching - Add'l	TBD	TBD	\$39.64	\$31.49	TBD	TBD	TBD	TBD	TBD	TBD
	NRC- DS3 DSC Termination with NRC- DS1 Switching - Disconnect - 1st	TBD	TBD	\$31.06	\$20.16	TBD	TBD	TBD	TBD	TBD	TBD
	NRC- DS3 DSC Termination with NRC- DS1 Switching - Disconnect - Add'l	TBD	TBD	\$24.98	\$20.16	TBD	TBD	TBD	TBD	TBD	TBD
	NRC-All Existing Combination "Switch As Is" Conversion Charge										
	NRC-DS1 COMBINATION - "Switch As Is" Conversion Charge - 1st	UNCCC	\$54.03	\$11.27	\$58.43	\$54.09	\$54.23	\$54.09	\$54.00	\$54.26	\$54.13
	NRC-DS1 COMBINATION - "Switch As Is" Conversion Charge - Add'l	UNCCC	\$32.11	\$11.27	\$26.99	\$32.16	\$32.24	\$32.16	\$32.10	\$32.25	\$32.17
	NRC- DS1 COMBINATION - "Switch As Is" Conversion Charge - Disconnect - 1st	UNCCC	\$0.00	\$13.03	\$12.61	\$0.00	\$0.00	\$0.00	\$0.00	\$0.00	\$0.00
	NRC- DS1 COMBINATION - "Switch As Is" Conversion Charge - Disconnect - Add'l	UNCCC	\$0.00	\$13.03	\$12.61	\$0.00	\$0.00	\$0.00	\$0.00	\$0.00	\$0.00
	Notes :										
	1 Deaveraged Rates will be effective May 1, 2000										
	2 New EELs will only be available in the State of Georgia and in density Zone 1 of the following MSAs in the BellSouth Region:										
	Florida - Miami, Orlando, Ft. Lauderdale										
	Louisiana - New Orleans										
	N. Carolina - Greensboro, Charlotte										
	Tennessee - Nashville										
	3 Unapproved rates are subject to true up.										
	4 Add together the recurring rates of all the applicable network elements in order to obtain total monthly recurring rate.										
	* Examples:										
	- 2-wire VG Loop + Voice Grade Interface Card + DS1 Channelization System + DS1 Interoffice Channel										
	- DS1 Loop + DS1 Interface Card + DS3 Channelization System + DS3 Interoffice Channel										
	- DS3 Local Channel + DS3 Interoffice Channel + DS3 Channelization System + DS1 Interface Card										
	The "Switch As Is" NRC applies to existing network combinations.										
	The Ordinarily Combined in GA NRC applies to new combinations within the State of Georgia.										

BELLSOUTH/LEVEL 3 RATES
NETWORK ELEMENTS
AND OTHER SERVICES

DESCRIPTION	USOC	AL	FL	GA	KY	LA	MS	NC	SC	TN
Operational Support Systems										
Recovery of incremental OSS costs, per CLP, per month	TBD	NA	NA	NA	NA	NA	NA	\$305.00	NA	NA
RC - OSS OLEC Daily Usage File: Recording, Per Message	TBD	\$0.0002	\$0.008	\$0.0001275	\$0.0008611	\$0.00019	\$0.0001179	\$0.0003	\$0.0002862	\$0.008
RC - OSS OLEC Daily Usage File: Message Processing, Per Message	TBD	\$0.0033	\$0.004	\$0.0062548	\$0.0032357	\$0.0024	\$0.0032089	\$0.0032	\$0.0032344	\$0.004
RC - OSS OLEC Daily Usage File: Message Distribution, Per Magnetic Tape	TBD	\$55.19	\$54.95	\$28.25	\$55.68	\$47.3000	\$54.62	\$54.61	\$54.72	\$54.95
RC - OSS OLEC Daily Usage File: Data Transmission (CONNECT:DIRECT), Per	TBD	\$0.00004	\$0.001	\$0.0000434	\$0.0000365	\$0.0000300	\$0.0000354	\$0.00004	\$0.0000357	\$0.001
Access Daily Usage File (ADUF)										
RC - ADUF, Message Processing, per message	TBD	\$0.004	\$0.004	\$0.0136327	\$0.004	\$0.004	\$0.004	\$0.004	\$0.004	\$0.004
RC - ADUF, Message Distribution, per Magnetic Tape provisioned	TBD	\$54.95	\$54.95	\$28.85	\$54.95	\$54.95	\$54.95	\$54.95	\$54.95	\$54.95
RC - ADUF, Data Transmission (CONNECT:DIRECT), per message	TBD	\$0.001	\$0.001	\$0.0000434	\$0.001	\$0.001	\$0.001	\$0.001	\$0.001	\$0.001
Enhanced Optional Daily Usage File (EODUF)										
Enhanced Optional Daily Usage File: Message Processing, Per Message	TBD	\$0.004	\$0.004	\$0.0034555	\$0.004	\$0.004	\$0.004	\$0.004	\$0.004	\$0.004
Enhanced Optional Daily Usage File: Message Processing, per magnetic tape	TBD	\$47.30	\$47.30	\$47.30	\$47.30	\$47.30	\$47.30	\$47.30	\$47.30	\$47.30
Enhanced Optional Daily Usage File: Data Transmission (CONNECT:DIRECT),	TBD	\$0.0000364	\$0.0000364	NA	\$0.0000364	\$0.0000364	\$0.0000364	\$0.0000364	\$0.0000364	\$0.0000364
SWA 8XX Toll Free Dialing Ten Digit Screening Service (Note 1)										
8XX Access Ten Digit Screening (all types), per call (Note 2)	N/A	\$0.0005	NA	\$0.0004868	NA	\$0.0005305	\$0.0005321	\$0.00050	\$0.0005227	NA
8XX Access Ten Digit Screening Svc. W/8XX No. Delivery										
per query	N/A	NA	NA	NA	\$0.0010	NA	NA	\$0.00365	NA	\$0.004
for 8XX Numbers, with Optional Complex Features, per query	N/A	NA	NA	NA	\$0.0011	NA	NA	\$0.00431	NA	\$0.004
8XX Access Ten Digit Screening Svc. W/POTS No. Delivery										
per query	N/A	NA	NA	NA	\$0.0010	NA	NA	\$0.00383	NA	\$0.004
with Optional Complex Features, per query	N/A	NA	NA	NA	\$0.0011	NA	NA	\$0.00431	NA	\$0.004
8XX Access Ten Digit Screening Svc. W/800 No. Delivery										
per message	N/A	NA	NA	NA	NA	NA	NA	NA	NA	NA
for 8XX Numbers, w/Optional Complex Features, per message	N/A	NA	NA	NA	NA	NA	NA	NA	NA	NA
8XX Access Ten Digit Screening Svc. W/POTS No. Delivery										
per message	N/A	NA	NA	NA	NA	NA	NA	NA	NA	NA
with Optional Complex Features, per message	N/A	NA	NA	NA	NA	NA	NA	NA	NA	NA
Reservation Charge per 8XX number reserved										
NRC - 1st	N8R1X	\$7.13	NA	\$6.57	\$10.05	\$6.29	\$8.46	\$7.05	\$6.38	\$30.00
NRC - Add'l	N8R1X	\$0.97	NA	\$0.76	\$1.19	\$0.73	\$0.96	\$0.96	\$0.9583	\$0.50
NRC - Incremental Charge - Manual Service Order - 1st	SOMAN	\$27.37	NA	\$18.94	NA	\$18.14	\$25.52	\$26.94	\$27.84	NA
NRC - Incremental Charge - Manual Service Order - Add'l	SOMAN	NA	NA	NA	NA	NA	NA	NA	NA	NA
Per 8XX # Established w/o POTS (w/8XX No.) Translations										
NRC - 1st	N/A	\$15.88	NA	\$12.81	\$30.59	\$12.27	\$17.04	\$23.82	\$22.63	\$67.50
NRC - Add'l	N/A	\$1.97	NA	\$1.45	\$3.22	\$1.39	\$1.93	\$2.73	\$2.73	\$1.50
NRC - Disconnect Charge - 1st	N/A	\$10.04	NA	NA	NA	\$8.30	\$11.32	NA	\$42.95	NA
NRC - Disconnect Charge - Add'l	N/A	\$0.97	NA	NA	NA	\$0.73	\$0.96	NA	NA	NA
NRC - Incremental Charge - Manual Service Order - 1st	SOMAN	\$27.37	NA	\$18.94	NA	\$18.14	\$25.52	\$41.35	NA	NA
NRC - Incremental Charge - Manual Service Order - Add'l	SOMAN	NA	NA	NA	NA	NA	NA	NA	NA	NA
NRC - Incremental Charge - Manual Service Order - Disconnect	SOMAN	\$17.75	NA	NA	NA	\$11.40	\$16.05	NA	NA	NA
Per 8XX # Established with POTS Translations										
NRC - 1st	N8FTX	\$15.88	NA	\$12.81	\$30.59	\$12.27	\$17.04	\$23.82	\$22.63	\$67.50
NRC - Add'l	N8FTX	\$1.97	NA	\$1.45	\$3.22	\$1.39	\$1.93	\$2.73	\$2.73	\$1.50
NRC - Disconnect Charge - 1st	N8FTX	\$10.04	NA	NA	NA	\$8.30	\$11.32	NA	\$42.95	NA
NRC - Disconnect Charge - Add'l	N8FTX	\$0.97	NA	NA	NA	\$0.73	\$0.96	NA	NA	NA
NRC - Incremental Charge - Manual Service Order - 1st	SOMAN	\$27.37	NA	\$18.94	NA	\$18.14	\$25.52	\$41.35	NA	NA
NRC - Incremental Charge - Manual Service Order - Add'l	SOMAN	NA	NA	NA	NA	NA	NA	NA	NA	NA
NRC - Incremental Charge - Manual Service Order - Disconnect	SOMAN	\$17.75	NA	NA	NA	\$11.40	\$16.05	NA	NA	NA
Customized Area of Service per 8XX Number										
NRC - 1st	N8FCX	\$5.69	NA	\$4.46	\$6.97	\$4.27	\$5.63	\$5.63	\$5.64	\$3.00
NRC - Add'l	N8FCX	\$2.85	NA	\$2.23	\$3.49	\$2.14	\$2.81	\$2.82	\$2.82	\$1.50
NRC - Incremental Charge - Manual Service Order - 1st	SOMAN	NA	NA	NA	NA	NA	NA	NA	NA	NA
NRC - Incremental Charge - Manual Service Order - Add'l	SOMAN	NA	NA	NA	NA	NA	NA	NA	NA	NA

BELLSOUTH/LEVEL 3 RATES
NETWORK ELEMENTS
AND OTHER SERVICES

DESCRIPTION	USOC	AL	FL	GA	KY	LA	MS	NC	SC	TN
Multiple Inter LATA Carrier Routing per Carrier Requested per 8XX #										
NRC - 1st	N8FMX	\$6.66	NA	\$5.22	\$8.16	\$5.00	\$6.59	\$6.59	\$6.60	\$3.50
NRC - Add'l	N8FMX	\$3.81	NA	\$2.99	\$4.67	\$2.86	\$3.77	\$3.77	\$3.78	\$2.00
NRC - Incremental Charge - Manual Service Order - 1st	SOMAN	NA	NA	NA	NA	NA	NA	NA	NA	NA
NRC - Incremental Charge - Manual Service Order - Add'l	SOMAN	NA	NA	NA	NA	NA	NA	NA	NA	NA
Change Charge per request										
NRC - 1st	N8FAX	\$8.10	NA	\$7.33	\$11.24	\$7.01	\$9.42	\$8.01	\$7.34	\$48.50
NRC - Add'l	N8FAX	\$0.97	NA	\$0.76	\$1.19	\$0.73	\$0.96	\$0.96	\$0.9583	\$0.50
NRC - Incremental Charge - Manual Service Order - 1st	SOMAN	\$27.37	NA	\$18.94	NA	\$18.14	\$25.52	\$26.94	\$27.84	NA
NRC - Incremental Charge - Manual Service Order - Add'l	SOMAN	NA	NA	NA	NA	NA	NA	NA	NA	NA
Call Handling and Destination Features										
NRC - 1st	N8FDX	\$5.69	NA	\$4.72	\$6.97	\$4.27	\$5.63	\$5.63	\$5.64	\$3.00
NRC - Add'l	N8FDX	NA	NA	\$4.46	\$6.97	\$4.27	\$5.63	NA	\$5.64	\$3.00
LINE INFORMATION DATABASE ACCESS (LIDB)										
LIDB Common Transport per query	OQT	\$0.00004	\$0.0003	\$0.0000338	\$0.00006	\$0.0000418	\$0.0000446	\$0.0003	\$0.0000442	\$0.0003
LIDB Validation per query	OQU	\$0.041003	\$0.041003	\$0.0105974	\$0.00938	\$0.0103774	\$0.0142132	\$0.013400	\$0.0141003	\$0.041003
LIDB Originating Point Code Establishment or Change - NRC										
NRC - Incremental Charge - Electronic Service Order	TBD	NA	NA	NA	NA	NA	NA	\$62.26	NA	NA
NRC - Incremental Charge - Manual Service Order - 1st	SOMAN	\$25.93	NA	\$18.94	NA	\$18.14	\$25.52	\$26.94	\$27.84	\$91.00
NRC - Incremental Charge - Manual Service Order - Add'l	SOMAN	NA	NA	NA	NA	NA	NA	NA	\$27.84	NA
CCS7 SIGNALING TRANSPORT SERVICE										
CCS7 Signaling Connection, per link (A link) per month										
NRC		\$18.79	\$5.00	\$17.05	\$16.31	\$19.48	\$21.58	\$155.00	\$21.79	\$155.00
NRC - Disconnect		\$171.98	\$400.00	\$131.96	\$354.95	\$126.34	\$169.72	\$510.00	\$277.07	\$510.00
NRC - Incremental Charge - Manual Service Order	SOMAN	\$135.70	NA	NA	NA	\$101.10	\$134.08	NA	\$42.95	NA
NRC - Incremental Charge - Manual Service Order - Disconnect	SOMAN	\$25.93	NA	\$18.94	NA	\$18.14	\$25.52	NA	NA	NA
		\$16.31	NA	NA	NA	\$11.40	\$16.05	NA	NA	NA
CCS7 Signaling Connection, per link (B link) (also known as D link) per month										
NRC		\$18.79	\$5.00	\$17.05	\$16.31	\$19.48	\$21.58	\$155.00	\$21.79	Not available
NRC - Disconnect		\$171.98	\$400.00	\$131.96	\$354.95	\$126.34	\$169.72	\$510.00	\$277.07	\$510.00
NRC - Incremental Charge - Manual Service Order	SOMAN	\$135.70	NA	NA	NA	\$101.10	\$134.08	NA	\$42.95	NA
NRC - Incremental Charge - Manual Service Order - Disconnect	SOMAN	\$25.93	NA	\$18.94	NA	\$18.14	\$25.52	NA	NA	NA
		\$16.31	NA	NA	NA	\$11.40	\$16.05	NA	NA	NA
CCS7 Signaling Termination, per STP port per month										
		\$148.72	\$113.00	\$133.99	\$174.08	\$161.99	\$161.12	\$132.88	\$156.33	\$355.00
CCS7 Signaling Usage, per ISUP message										
		\$0.00004	\$0.00001	\$0.0000354	\$0.000037893	\$0.0000430	\$0.0000456	\$0.00004	\$0.0000452	\$0.000023
(applicable when measurement and billing capability exists.)										
CCS7 Signaling Usage, per TCAP message										
		\$0.0001	\$0.00004	\$0.0000870	\$0.000102042	\$0.0001052	\$0.0001115	\$0.00009	\$0.0001108	\$0.00005
(applicable when measurement and billing capability exists.)										
CCS7 Signaling Usage Surrogate, per link per LATA per mo (9)										
		\$376.12	\$64.00	\$340.67	\$329.98	\$406.71	\$406.53	\$338.98	\$396.55	\$395.00
CCS7 Signaling Point Code, Establishment or Change, per STP affected										
NRC		\$62.00	\$62.00	\$62.00	\$62.00	\$62.00	\$62.00	\$62.00	\$62.00	\$62.00
OPERATOR CALL PROCESSING										
Operator Provided Call Handling per min - Using BST LIDB										
Call Completion Access Termination Charge per call attempt	N/A	\$1.21	\$1.00	\$0.9680296	\$1.6016	\$0.91	\$1.19	\$1.20	\$1.21	NA
Operator Provided Call Handling per min - Using Foreign LIDB	N/A	\$0.08	NA	NA	NA	NA	NA	NA	\$0.08	NA
Call Completion Access Termination Charge per call attempt	N/A	\$1.25	\$1.00	\$1.02	\$1.6249	\$0.96	\$1.24	\$1.24	\$1.25	NA
Operator Provided Call Handling, per call	N/A	\$0.08	NA	NA	NA	NA	NA	NA	\$0.08	NA
Fully Automated Call Handling per call - Using BST LIDB	N/A	NA	NA	NA	NA	NA	NA	NA	NA	\$0.30
Fully Automated Call Handling per call - Using Foreign LIDB	N/A	\$0.11	\$0.10	\$0.0776409	\$0.0856	\$0.10	\$0.1072884	\$0.11	\$0.1115808	\$0.15
Professional recording of name (OCP alone)	USOD1	\$0.13	\$0.10	\$0.0976984	\$0.1071	\$0.12	\$0.1253666	\$0.12	\$0.1293459	\$0.15
Professional recording of name (DA and OCP alone)	USOD1	\$7,000.00	\$7,000.00	\$7,000.00	\$7,000.00	\$7,000.00	\$7,000.00	\$7,000.00	\$7,000.00	\$7,000.00
DRAM or front-end loading, per TOPS switch	USOD2	\$7,000.00	\$7,000.00	\$7,000.00	\$7,000.00	\$7,000.00	\$7,000.00	\$7,000.00	\$7,000.00	\$7,000.00
AABS or back-end loading, per IVS	USOD2	\$250.00	\$250.00	\$250.00	\$250.00	\$250.00	\$250.00	\$250.00	\$250.00	\$250.00
EBAS or 0- automation loading, per NAV shelf	USOD2	\$225.00	\$225.00	\$225.00	\$225.00	\$225.00	\$225.00	\$225.00	\$225.00	\$225.00
Recording Charge per Branded Announcement - Disconnect - Initial	USOD2	\$270.00	\$270.00	\$270.00	\$270.00	\$270.00	\$270.00	\$270.00	\$270.00	\$270.00
	N/A	\$9.61	NA	NA	NA	NA	NA	NA	NA	NA

BELLSOUTH/LEVEL 3 RATES
NETWORK ELEMENTS
AND OTHER SERVICES

DESCRIPTION	USOC	AL	FL	GA	KY	LA	MS	NC	SC	TN
Recording Charge per Branded Announcement – Disconnect – Subsequent	N/A	\$9.61	NA	NA	NA	NA	NA	NA	NA	NA
INWARD OPERATOR SERVICES										
Verification, per minute	N/A	\$1.16	NA	\$0.921083	NA	\$0.86	\$1.14	\$1.15	\$1.15	NA
Verification and Emergency Interrupt, per minute	N/A	\$1.16	NA	\$0.921083	NA	\$0.86	\$1.14	\$1.15	\$1.15	NA
Verification, per call	VIL	NA	\$0.80	NA	\$1.00	NA	NA	\$0.54	NA	\$0.90
Verification and Emergency Interrupt, per call	N/A	NA	\$1.00	NA	\$1.111	NA	NA	\$0.65	NA	\$1.95
DIRECTORY ASSISTANCE SERVICES										
Directory Assist Call Completion Access Svc (DACC), per call attempt	N/A	\$0.10	\$0.10	\$0.10	\$0.10	\$0.10	\$0.10	\$0.062	\$0.10	\$0.10
Call Completion Access Term charge per completed call	N/A	NA	NA	NA	NA	NA	NA	NA	\$0.08	NA
Number Services Intercept per query	N/A	\$0.0235	\$0.01	\$0.0097497	\$0.0086	\$0.02	\$0.0188268	\$0.0110	\$0.0124036	\$0.15
Number Services Intercept per Intercept Query Update	N/A	NA	NA	NA	\$0.0055	NA	NA	NA	NA	NA
Directory Assistance Access Service Calls, per call	N/A	\$0.275	\$0.275	\$0.275	\$0.275	\$0.275	\$0.275	\$0.260000	\$0.275	\$0.275
Professional recording of name (DA alone)	N/A	\$3,000.00	\$3,000.00	\$3,000.00	\$3,000.00	\$3,000.00	\$3,000.00	\$3,000.00	\$3,000.00	\$3,000.00
Professional recording of name (DA and OCP alone)	N/A	\$7,000.00	\$7,000.00	\$7,000.00	\$7,000.00	\$7,000.00	\$7,000.00	\$7,000.00	\$7,000.00	\$7,000.00
DRAM or front-end loading, per TOPS switch	N/A	\$250.00	\$250.00	\$250.00	\$250.00	\$250.00	\$250.00	\$250.00	\$250.00	\$250.00
AABS or back-end loading, per IVS	N/A	\$225.00	\$225.00	\$225.00	\$225.00	\$225.00	\$225.00	\$225.00	\$225.00	\$225.00
EBAS or 0- automation loading, per NAV shelf	N/A	\$270.00	\$270.00	\$270.00	\$270.00	\$270.00	\$270.00	\$270.00	\$270.00	\$270.00
Recording Charge per Branded Announcement – Disconnect – Initial	N/A	\$9.61	NA	NA	NA	NA	NA	NA	NA	NA
Recording Charge per Branded Announcement – Disconnect – Subsequent	N/A	\$9.61	NA	NA	NA	NA	NA	NA	NA	NA
Directory Transport										
Directory Transport - Local Channel DS1, per month	N/A	\$35.52	\$43.64	\$38.36	\$36.32	\$43.83	\$38.91	\$35.68	\$37.20	\$133.81
NRC - 1st	N/A	\$503.57	\$242.45	\$356.15	\$637.46	\$339.69	\$494.83	\$534.48	\$534.81	\$868.97
NRC - Add'l	N/A	\$442.84	\$226.44	\$312.89	\$546.94	\$298.29	\$435.28	\$462.69	\$462.81	\$486.83
NRC - Disconnect Charge - 1st	N/A	\$46.28	NA	NA	NA	\$33.02	\$46.85	NA	NA	NA
NRC - Disconnect Charge - Add'l	N/A	\$32.18	NA	NA	NA	\$23.32	\$33.02	NA	NA	NA
NRC - Incremental Charge-Manual Svc Order - NRC - 1st	SOMAN	\$61.99	NA	\$44.22	NA	\$42.34	\$59.58	\$86.15	\$87.99	NA
NRC - Incremental Charge-Manual Svc Order - NRC -add'l	TBD	NA	NA	NA	NA	NA	NA	\$1.77	NA	NA
NRC - Incremental Charge-Manual Svc Order - NRC-Disconnect	SOMAN	\$29.27	NA	NA	NA	\$19.48	\$27.41	NA	\$3.11	NA
Directory Transport - Dedicated DS1 Level Interoffice per mile per mo	N/A	\$0.6923	\$0.6013	\$0.4523	\$0.45	\$0.78	\$0.6598	\$0.5753	\$0.7598	\$23.00
Directory Transport - Dedicated DS1 Level Interoffice per facility termination per m	N/A	\$79.69	\$99.79	\$78.47	\$55.05	\$93.40	\$74.40	\$71.29	\$94.98	\$90.00
NRC - 1st	N/A	\$198.15	\$45.91	\$147.07	\$298.18	\$140.49	\$196.28	\$217.17	\$216.27	\$100.49
NRC - Add'l	N/A	\$148.18	\$44.18	\$111.75	\$231.18	\$106.69	\$147.31	\$163.75	\$162.70	\$100.49
NRC - Disconnect Charge - 1st	N/A	\$25.44	NA	NA	NA	\$20.00	\$26.56	NA	NA	NA
NRC - Disconnect Charge - Add'l	N/A	\$20.42	NA	NA	NA	\$16.34	\$21.61	NA	NA	NA
NRC - Incremental Charge - Manual Service Order - 1st	SOMAN	\$27.37	NA	\$18.94	NA	\$18.14	\$25.52	\$38.07	\$39.63	NA
NRC - Incremental Charge - Manual Service Order - Add'l	SOMAN	\$27.37	NA	NA	NA	\$18.14	\$25.52	\$38.07	\$39.63	NA
NRC - Incremental Charge - Manual Service Order - Disconnect - 1st	SOMAN	\$12.97	NA	NA	NA	\$8.06	\$11.34	NA	NA	NA
NRC - Incremental Charge - Manual Service Order - Disconnect - Add'l	SOMAN	\$12.97	NA	NA	NA	\$8.06	\$11.34	NA	NA	NA
Switched Common Transport per DA Access Service per call	N/A	\$0.0003	\$0.0003	\$0.0002906	\$0.000175	\$0.0003274	\$0.0002997	\$0.00020	\$0.000327	NA
Switched Common Transport per DA Access Service per call per mile	N/A	\$0.00003	\$0.00001	\$0.0000186	\$0.000004	\$0.0000175	\$0.0000202	\$0.00003	\$0.0000303	NA
Access Tandem Switching per DA Access Service per call	N/A	\$0.0023	\$0.00055	\$0.0019152	\$0.000783	\$0.0025257	\$0.0023713	\$0.0021	\$0.0024809	NA
DA Interconnection, per DA Access Service Call	N/A	\$0.00269	NA	\$0.00269	NA	NA	NA	\$0.00	\$0.000269	NA
Directory Transport-Installation NRC, per trunk or signaling connection										
NRC - 1st	N/A	\$260.69	\$206.06	\$204.23	\$501.98	\$195.54	\$257.73	NA	\$407.81	NA
NRC - Add'l	N/A	\$5.95	\$4.71	\$4.42	\$13.32	\$4.23	\$5.85	NA	\$11.00	NA
NRC - Disconnect Charge - 1st	N/A	\$173.46	NA	NA	NA	NA	NA	NA	NA	NA
NRC - Disconnect Charge - Add'l	N/A	\$5.95	NA	NA	NA	NA	NA	NA	NA	NA
NRC - Incremental Charge - Manual Service Order - 1st	SOMAN	NA	NA	\$44.22	NA	\$130.05	\$171.49	NA	NA	NA
NRC - Incremental Charge - Manual Service Order - Add'l	SOMAN	NA	NA	NA	NA	\$4.23	\$5.85	NA	NA	NA
NRC - Manual Service Order - 1st	TBD	NA	NA	NA	NA	NA	NA	\$407.53	NA	NA
NRC - Manual Service Order - Add'l	TBD	NA	NA	NA	NA	NA	NA	\$10.98	NA	NA
Directory Assistance Database Service (DADS)										
Directory Assistance Database Service charge per listing	N/A	\$0.0446	\$0.001	\$0.0445	\$0.0193	\$0.0443	\$0.0447	\$0.04460	\$0.0444	NA

BELLSOUTH/LEVEL 3 RATES
NETWORK ELEMENTS
AND OTHER SERVICES

DESCRIPTION	USOC	AL	FL	GA	KY	LA	MS	NC	SC	TN
Directory Assistance Database Service, per month	DBSOF	\$128.55	\$100.00	\$95.50	\$120.76	\$90.54	\$126.17	\$126.26	\$127.23	NA
Direct Access to Directory Assistance Service (DADAS)										
Direct Access to Directory Assistance Service, per month	DBSDS	\$7,055.00	\$5,000.00	\$5,254.00	\$7,235.01	\$4,982.00	\$6,926.00	\$6,930.00	\$6,983.00	NA
Direct Access to Directory Assistance Service, per query	DBSDA	\$0.0472685	\$0.01	\$0.0469016	\$0.0052	\$0.0460	\$0.0461336	\$0.0456	\$0.0468212	NA
Direct Access to Directory Assistance Service, svc estab charge	DBSDE									
NRC	DBSDE	\$1,118.00	\$820.00	\$788.24	\$1,186.94	\$786.82	\$1,097.00	\$1,164.00	\$1,173.00	NA
NRC - Disconnect	DBSDE	\$81.83	NA	NA	NA	NA	NA	NA	NA	NA
NRC - Incremental Charge Manual Service Order - 1st	SOMAN	NA	NA	NA	NA	\$57.23	\$80.52	NA	NA	NA
AIN (Note 4)										
AIN, per message	CAM	NA	\$0.00004	NA	NA	NA	NA	NA	NA	TBD
AIN - BellSouth AIN SMS Access Service	CAM								NA	NA
Service Establishment Charge, per state, initial set-up										
NRC	CAMSE	\$197.49	NA	\$90.25	NA	\$153.31	\$174.03	\$294.77	\$296.16	NA
NRC - Disconnect	CAMSE	\$114.22	NA	NA	NA	\$78.06	\$135.96	NA	NA	NA
Port Connection - Dial/Shared Access										
NRC	CAMDP	\$64.05	NA	\$29.66	NA	\$50.07	\$53.47	\$86.94	\$87.29	NA
NRC - Disconnect	CAMDP	\$27.04	NA	NA	NA	\$18.61	\$37.70	NA	NA	NA
Port Connection - ISDN Access										
NRC	CAM1P	\$64.05	NA	\$29.66	NA	\$50.07	\$53.47	\$86.94	\$87.29	NA
NRC - Disconnect	CAM1P	\$27.04	NA	NA	NA	\$18.61	\$37.70	NA	NA	NA
User ID Codes - per User ID Code										
NRC	CAMAU	\$141.84	NA	\$84.43	NA	\$104.95	\$129.83	\$200.83	\$202.08	NA
NRC - Disconnect	CAMAU	\$70.05	NA	NA	NA	\$48.95	\$79.91	NA	NA	NA
Security Card per User ID Code, initial or replacement										
NRC	CAMRC	\$142.13	NA	\$35.44	NA	\$125.33	\$131.54	\$172.05	\$172.26	NA
NRC - Disconnect	CAMRC	\$35.26	NA	NA	NA	\$24.40	\$45.77	NA	NA	NA
Storage, per unit (100Kb)	N/A	\$0.0026	NA	\$0.0023	NA	\$0.0029	\$0.0029	\$0.0023	\$0.0028	NA
Session per minute	N/A	\$0.0892	NA	\$0.0795604	NA	\$0.10	\$0.0975650	\$0.0791	\$0.0942966	NA
C0. Performed Session, per minute					NA	\$1.97	\$2.09	\$2.08	\$2.07	NA
AIN - BellSouth AIN Toolkit Service										
AIN, Service Creation Tools	CAMBP	NA	TBD	NA	NA	NA	NA	NA	NA	NA
Service Establishment Charge, per state, initial set-up										
NRC	BAPSC	\$192.69	NA	\$86.74	NA	\$153.25	\$169.31	\$290.05	\$291.41	NA
NRC - Disconnect	BAPSC	\$114.22	NA	NA	NA	\$78.05	\$135.96	NA	NA	NA
Training Session, per customer										
NRC	BAPVX	\$8,363.00	NA	\$8,348.00	NA	\$8,315.00	\$8,379.00	\$8,363.00	\$8,333.00	NA
NRC - Disconnect	BAPVX	NA	NA	NA	NA	NA	NA	NA	NA	NA
Trigger Access Charge, per trigger, per DN, Term. Attempt										
NRC	BAPTT	\$49.64	NA	\$19.13	NA	\$41.08	\$39.30	\$72.76	\$73.02	NA
NRC - Disconnect	BAPTT	\$27.04	NA	NA	NA	\$18.60	\$37.70	NA	NA	NA
Trigger Access Charge, per trigger per DN, Off-Hook Delay										
NRC	BAPTD	\$49.64	NA	\$114.80	NA	\$41.08	\$39.30	\$72.76	\$73.02	NA
NRC - Disconnect	BAPTD	\$27.04	NA	NA	NA	\$18.60	\$37.70	NA	NA	NA
Trigger Access Charge, per trigger, per DN, Off-Hook Immediate										
NRC	BAPTM	\$49.64	NA	\$19.13	NA	\$41.08	\$39.30	\$72.76	\$73.02	NA
NRC - Disconnect	BAPTM	\$27.04	NA	NA	NA	\$18.60	\$37.70	NA	NA	NA
Trigger Access Charge, per trigger, per DN, 10-Digit PODP										
NRC	BAPTO	\$117.98	NA	\$70.06	NA	\$92.99	\$106.90	\$149.95	\$150.25	NA
NRC - Disconnect	BAPTO	\$37.90	NA	NA	NA	\$26.73	\$48.44	NA	NA	NA
Trigger Access Charge, per trigger, per DN, CDP										
NRC	BAPTC	\$117.98	NA	\$70.06	NA	\$92.99	\$106.90	\$149.95	\$150.25	NA
NRC - Disconnect	BAPTC	\$37.90	NA	NA	NA	\$26.73	\$48.44	NA	NA	NA
Trigger Access Charge, per trigger, per DN, Feature Code										

BELLSOUTH/LEVEL 3 RATES
NETWORK ELEMENTS
AND OTHER SERVICES

DESCRIPTION	USOC	AL	FL	GA	KY	LA	MS	NC	SC	TN
NRC	BAPTF	\$117.98	NA	\$70.06	NA	\$92.99	\$106.90	\$149.95	\$150.25	NA
NRC - Disconnect	BAPTF	\$37.90	NA	NA	NA	\$26.73	\$48.44	NA	NA	NA
Query Charge, per query		\$0.024	NA	\$0.0209223	NA	\$0.03	\$0.0256138	\$0.02	\$0.0250662	NA
Type 1 Node Charge, per AIN Toolkit Subscription, per node, per query		\$0.006	NA	\$0.0053137	NA	\$0.0065	\$0.0065161	\$0.005	\$0.0062979	NA
SCP Storage Charge, per SMS Access Acct, per 100 Kb										
	N/A	\$1.63	NA	\$1.46	NA	\$1.79	\$1.79	\$1.45	\$1.73	NA
Monthly Report - per AIN Toolkit Service Subscription										
	BAPMS	\$16.00	NA	\$15.96	NA	\$15.89	\$16.01	\$15.98	\$15.93	NA
NRC	BAPMS	\$44.56	NA	\$22.64	NA	\$34.61	\$44.02	\$71.80	\$72.15	NA
NRC - Disconnect	BAPMS	\$31.84	NA	NA	NA	\$21.97	\$31.28	NA	NA	NA
Special Study - per AIN Toolkit Service Subscription										
	BAPLS	\$0.10	NA	\$0.0861109	NA	\$0.08	\$0.0810536	\$0.08	\$0.0872769	NA
NRC	BAPLS	\$47.74	NA	\$22.64	NA	\$37.77	\$47.21	\$47.20	\$47.35	NA
NRC - Disconnect	BAPLS	\$15.90	NA	NA	NA	NA	NA	NA	NA	NA
Call Event Report - per AIN Toolkit Service Subscription										
	BAPDS	\$15.90	NA	\$15.87	NA	\$15.81	\$15.93	\$15.90	\$15.84	NA
NRC	BAPDS	\$44.56	NA	\$22.64	NA	\$34.61	\$44.02	\$71.80	\$72.15	NA
NRC - Disconnect	BAPDS	\$31.84	NA	NA	NA	\$21.97	\$31.28	NA	NA	NA
Call Event special Study - per AIN Toolkit Service Subscription										
	BAPES	\$0.003	NA	\$0.0028704	NA	\$0.0026	\$0.0027018	\$0.003	\$0.0029092	NA
NRC	BAPES	\$47.74	NA	\$22.64	NA	\$37.77	\$47.21	\$47.20	\$47.35	NA
NRC - Disconnect	BAPES	\$15.90	NA	NA	NA	\$37.77	NA	NA	NA	NA
CALLING NAME (CNAM) QUERY SERVICE										
CNAM (Database Owner), Per Query										
	N/A	\$0.016	\$0.016	\$0.016	\$0.016	\$0.016	\$0.016	\$0.016	\$0.016	\$0.016
CNAM (Non-Database Owner), Per Query *										
	N/A	\$0.01	\$0.01	\$0.01	\$0.01	\$0.01	\$0.01	\$0.01	\$0.01	\$0.01
NRC, applicable when CLEC-1 uses the Character Based User Interface (CHUI)										
	N/A	\$595.00	\$595.00	\$595.00	\$595.00	\$595.00	\$595.00	\$595.00	\$595.00	\$595.00
* Volume and term arrangements are also available.										
SELECTIVE ROUTING (Note 5)										
Per Line or PBX Trunk, each										
		NA	NA	NA	\$10.00 (Interim)	NA	NA	NA	NA	TBD
NRC		NA	NA	NA	NA	NA	NA	NA	NA	TBD
Customized routing per unique line class code, per request, per switch										
		NA	NA	NA	NA	NA	NA	NA	NA	NA
NRC	USRCR	\$230.60	\$229.65	\$180.62	\$229.65	\$229.65	\$227.99	\$229.65	\$226.22	\$229.65
NRC - Incremental Charge - Manual Service Order		\$25.93	NA	\$18.94	NA	NA	\$253.51	NA	\$27.84	NA
VIRTUAL COLLOCATION										
NRC - Virtual Collocation - Application Cost - Manual										
	TBD	NA	NA	NA	NA	NA	NA	\$3,622.00	NA	NA
NRC - Virtual Collocation - Cable Installation Cost per Cable - Manual										
	TBD	NA	NA	NA	NA	NA	NA	\$2,305.00	NA	NA
RC - Virtual Collocation - Floor space per square feet										
	TBD	NA	NA	NA	NA	NA	NA	\$3.45	NA	NA
RC - Virtual Collocation - Floor space power, per ampere										
	TBD	NA	NA	NA	NA	NA	NA	\$6.65	NA	NA
RC - Virtual Collocation - Cable support structure, per entrance cable										
	TBD	NA	NA	NA	NA	NA	NA	\$18.66	NA	NA
2-wire Cross-Connect										
	UEAC2	\$0.28	\$0.524	\$0.30	\$0.31	\$0.26	\$0.3996	\$0.09	\$0.3648	\$0.30
NRC - 1st	UEAC2	\$30.76	\$11.57	\$12.60	\$54.21	\$23.04	\$30.93	\$41.78	\$41.50	\$19.20
NRC - Add'l	UEAC2	\$29.40	\$11.57	\$12.60	\$51.07	\$22.11	\$29.59	\$39.23	\$38.94	\$19.20
NRC - 1st - Manual Service Order										
	TBD	NA	NA	NA	NA	NA	NA	\$4.75	NA	NA
NRC - Add'l - Manual Service Order										
	TBD	NA	NA	NA	NA	NA	NA	\$4.75	NA	NA
NRC - Disconnect - 1st										
	UEAC2	\$12.75	NA	NA	NA	\$9.48	\$12.76	NA	NA	NA
NRC - Disconnect - Add'l										
	UEAC2	\$11.38	NA	NA	NA	\$8.54	\$11.43	NA	NA	NA
4-wire Cross-Connect										
	UEAC4	\$0.56	\$0.524	\$0.50	\$0.62	\$0.52	\$0.7992	\$0.18	\$0.7297	\$0.50
NRC - 1st	UEAC4	\$66.71	\$11.57	\$12.60	\$54.23	\$23.23	\$31.17	\$41.91	\$41.56	\$19.20
NRC - Add'l	UEAC4	\$50.43	\$11.57	\$12.60	\$50.96	\$22.24	\$29.77	\$39.25	\$38.90	\$19.20
NRC - 1st - Manual Service Order										
	TBD	NA	NA	NA	NA	NA	NA	\$4.73	NA	NA
NRC - Add'l - Manual Service Order										
	TBD	NA	NA	NA	NA	NA	NA	\$4.73	NA	NA
NRC - Disconnect - 1st										
	UEAC4	\$12.82	NA	NA	NA	\$9.53	\$12.83	NA	NA	NA
NRC - Disconnect - Add'l										
	UEAC4	\$11.39	NA	NA	NA	\$8.55	\$11.43	NA	NA	NA
2-fiber Cross-Connect										
	CNC2F	\$12.10	NA	\$15.64	\$15.64	\$19.13	\$15.64	\$15.99	\$15.06	\$15.64

BELLSOUTH/LEVEL 3 RATES
NETWORK ELEMENTS
AND OTHER SERVICES

DESCRIPTION	USOC	AL	FL	GA	KY	LA	MS	NC	SC	TN
NRC - 1st	CNC2F	\$55.46	NA	\$41.56	\$41.56	\$41.07	\$41.56	\$67.34	\$69.28	\$41.56
NRC - Add'l	CNC2F	\$39.18	NA	\$29.82	\$29.82	\$29.63	\$29.82	\$48.55	\$48.89	\$29.82
NRC - Disconnect - 1st	CNC2F	\$16.83	NA	NA	NA	\$12.84	\$12.96	NA	NA	NA
NRC - Disconnect - Add'l	CNC2F	\$13.27	NA	NA	NA	\$10.29	\$10.34	NA	NA	NA
4-fiber Cross-Connect										
RC	CNC4F	\$21.75	NA	\$28.11	\$28.11	\$34.38	\$28.11	\$28.74	\$27.08	\$28.11
NRC - 1st	CNC4F	\$66.71	NA	\$50.53	\$50.53	\$49.81	\$50.53	\$82.35	\$84.07	\$50.53
NRC - Add'l	CNC4F	\$50.43	NA	\$38.78	\$38.78	\$38.37	\$38.78	\$63.56	\$63.68	\$38.78
NRC - Disconnect - 1st	CNC4F	\$21.86	NA	NA	NA	\$16.75	\$16.97	NA	NA	NA
NRC - Disconnect - Add'l	CNC4F	\$18.31	NA	NA	NA	\$14.20	\$14.35	NA	NA	NA
DS1 Cross-Connects										
RC	TBD	NA	NA	NA	NA	NA	NA	\$0.97	NA	NA
NRC - 1st	TBD	NA	NA	NA	NA	NA	NA	\$71.02	NA	NA
NRC - Add'l	TBD	NA	NA	NA	NA	NA	NA	\$51.08	NA	NA
NRC - Manual Service Order - 1st	TBD	NA	NA	NA	NA	NA	NA	\$4.70	NA	NA
NRC - Manual Service Order - Add'l	TBD	NA	NA	NA	NA	NA	NA	\$4.70	NA	NA
DS3 Cross-Connects										
RC	TBD	NA	NA	NA	NA	NA	NA	\$12.33	NA	NA
NRC - 1st	TBD	NA	NA	NA	NA	NA	NA	\$69.84	NA	NA
NRC - Add'l	TBD	NA	NA	NA	NA	NA	NA	\$49.43	NA	NA
NRC - Manual Service Order - 1st	TBD	NA	NA	NA	NA	NA	NA	\$4.70	NA	NA
NRC - Manual Service Order - Add'l	TBD	NA	NA	NA	NA	NA	NA	\$4.70	NA	NA
If no rate is identified in the contract, the rate for the specific service or function will be as set forth in applicable BellSouth tariff or as negotiated by the parties upon request by either party.										
1	BellSouth and CLEC shall negotiate rates for this offering. If agreement is not reached within sixty (60) days of the Effective Date, either party may petition the Florida PSC to settle the disputed charge or charges. (FL)									
2	This rate element is for those states w/o separate rates for 800 calls with 800 No. Delivery vs. POTS No. Delivery and calls with Optional Complex Features vs. w/o Optional Complex Features.									
3	This charge is only applicable where signaling usage measurement or billing capability does not exist.									
4	Prices for AIN to be determined upon development of mediation device. (TN)									
5	Price for Line Class Codes for Selective Routing shall be determined by the TRA. (TN)									

Attachment 3
Network Interconnection

TABLE OF CONTENTS

1. Network Interconnection.....	<u>33</u>
2. Interconnection Trunk Group Architectures	<u>78</u>
3. Network Design And Management For Interconnection	<u>1415</u>
4. Local Dialing Parity.....	<u>1919</u>
5. Interconnection Compensation	<u>1920</u>
6. Frame Relay Service Interconnection	<u>2728</u>
7. Operational Support Systems (OSS).....	31
Rates.....	Exhibit A
Basic Architecture	Exhibit B
One Way Architecture	Exhibit C
Two Way Architecture	Exhibit D
Supergroup Architecture	Exhibit E

The Parties shall provide interconnection with each other's networks for the transmission and routing of telephone exchange service ("Local Traffic," as further defined in Section 5.1.1 of this Attachment), traffic destined for Internet Service Providers ("ISP-bound Traffic") and exchange access (IntraLATA Toll Traffic and Switched Access Traffic) on the following terms:

1. Network Interconnection

All negotiated rates, terms and conditions set forth in this Attachment pertain only to the provision of network interconnection where Level 3 owns and provides its switch(es).

1.1 Network Interconnection for call transport and termination will be provided by BellSouth at any technically feasible point. Requests to BellSouth for interconnection at points other than as set forth in this Attachment may be made through the Bona Fide Request/New Business Request process set out in General Terms and Conditions.

1.1.1 An Interconnection Point (IP) is the physical telecommunications equipment interface that performs the interconnection function for BellSouth and Level 3. Each Party is financially and operationally responsible for providing the network on its side of the IP. Furthermore, the IP must be located within BellSouth's serving territory in the LATA in which Local Traffic is originating. The IP determines the point at which the originating Party shall pay the terminating Party for the call transport and termination of that traffic.

1.1.1.1 Pursuant to the provisions of this Attachment, the location of the initial Interconnection Point in a given LATA shall be established by mutual agreement of the Parties. If the Parties are unable to agree to a mutual initial Interconnection Point, each Party, as originating Party, may establish a single Interconnection Point in the LATA for the delivery of its originated Local Traffic, ISP-bound Traffic, and IntraLATA Toll Traffic to the other Party for call transport and termination by the terminating Party. When the Parties mutually agree to utilize two-way interconnection trunk groups for the exchange of Local Traffic, ISP-bound Traffic and IntraLATA Toll Traffic between each other, the Parties shall mutually agree to the location of Interconnection Point(s). Additional Interconnection Points in a particular LATA may be established by mutual agreement of the Parties. Absent mutual agreement, in order to establish additional Interconnection Points in a LATA, the traffic between Level 3 and BellSouth at the proposed additional Interconnection Point must exceed 8.9 million minutes of Local Traffic or ISP-bound Traffic per month for three consecutive months during the busy hour. Additionally, any end office to be designated as an Interconnection Point must be more than 20 miles from an existing Interconnection Point. BellSouth will not designate an Interconnection

Point at a Central Office where physical or virtual collocation space or BellSouth fiber connectivity is not available, and BellSouth will not designate more than one Interconnection Point per local calling area unless such local calling area exceeds sixty (60) miles in any one direction, in which case additional Interconnection Points may only be established in that local calling area pursuant to the other criteria set forth in this section.

Upon written notification from the Party requesting the establishment of an additional Interconnection Point, the receiving Party has 45 calendar days to analyze, respond to, and negotiate in good faith the establishment of and location of such Interconnection Point. Should the Parties disagree that the traffic volumes justify an additional Interconnection Point or disagree as to the location of an additional Interconnection Point, the Parties shall follow the Dispute Resolution process under this Agreement to determine whether and how the additional Interconnection Point should be established.

- 1.1.1.2 The Parties will convert all existing interconnection arrangements and trunks to the interconnection arrangements described in this Attachment in accordance with the following. Within 60 days of either Party's request, the Parties will mutually develop an operations plan based on sound engineering and operations principles, which will specify the guidelines to convert from the existing interconnection arrangements to the interconnection arrangements described in this Attachment 3. Such guidelines will conform to standard industry practices adopted by and contained in documents published by industry forums, including, but not limited to, the Alliance for Telecommunications Industry Solutions and the Ordering and Billing forum. Each Party shall bear its own costs to convert from the existing interconnection arrangements to the interconnection arrangements described in this Attachment 3. If, following one (1) year after the date of last signature to this Agreement, there exists any interconnection arrangements which have not been converted to the interconnection arrangements described in this Attachment 3, then either Party may invoke the dispute resolution process, pursuant to Section 16 of the General Terms and Conditions of this Agreement, incorporated herein by this reference. Notwithstanding any reconfiguration of existing Interconnection Points required in existing markets, Level 3 shall be permitted to order both new trunk groups and to augment trunk groups at the existing Interconnection Point during the time that any reconfiguration of Interconnection Points is taking place.

1.2 **Interconnection via Leased Dedicated Transport Facilities**

- 1.2.1 The Parties shall institute a "bill and keep" compensation plan under which neither Party will charge the other Party recurring and nonrecurring charges for trunks (one-way or two-way) and associated dedicated facilities for the exchange of Local Traffic (non-transit), ISP-bound Traffic, and IntraLATA Toll Traffic. Each Party has the obligation to install the appropriate trunks and associated facilities on its

respective side of the Interconnection Point and is responsible for bearing its own costs on its side of the Interconnection Point. Both Parties, as appropriate, shall be compensated for the ordering of trunks and facilities used exclusively for transit traffic and for ancillary traffic types including, but not limited to, 911 and OS/DA. The Parties agree that charges for such trunks and facilities are as set forth in Exhibit A to this Attachment. In the event that a Party chooses to lease facilities from the other Party in lieu of installing facilities on its side of the Interconnection Point as required by Section 1.1.1.1 and this Section 1.2.1, such facilities are not subject to “bill and keep,” but shall be purchased in accordance with 1.2.2 and 1.2.3. Nothing in this Section affects either Party’s obligation set forth in Section 5.1.

- 1.2.2 In lieu of providing facilities on its side of Interconnection Point, either Party may purchase Local Channel facilities from the other Party, at the cost-based rates identified in Exhibit A to this Attachment, from the leasing Party’s switch or Point of Presence to that Party’s serving wire center. The portion of Local Channel facilities utilized for Local Traffic and ISP-bound Traffic shall be determined based upon the application of the Percent Local Facility (PLF) Factor as defined in this Attachment. Additionally, the charges applied to the portion of the Local Channel used for Local Traffic and ISP-bound Traffic as determined by the PLF are as set forth in Exhibit A to this Attachment. This factor shall be reported in addition to the switched dedicated transport jurisdictional factors specified in the BellSouth intrastate and interstate switched access tariffs.
- 1.2.3 Additionally, in lieu of providing facilities on its side of the Interconnection Point, either Party may purchase, at the cost-based rates identified in Exhibit A to this Attachment, Dedicated Interoffice Transport facilities from its designated serving wire center to the Interconnection Point. The portion of Dedicated Interoffice Transport facilities utilized for Local Traffic and ISP-bound Traffic shall be determined based upon the application of the Percent Local Facility (PLF) Factor as defined in this Attachment. Additionally, the charges applied to the portion of the Dedicated Interoffice Transport used for Local Traffic and ISP-bound Traffic as determined by the PLF are as set forth in Exhibit A to this Attachment. This factor shall be reported in addition to the switched dedicated transport jurisdictional factors specified in the BellSouth intrastate and interstate switched access tariffs.
- 1.2.4 For the purposes of this Attachment, **Local Channel** is defined as a switch transport facility between the leasing Party’s Point of Presence and that Party’s serving wire center.
- 1.2.5 For the purposes of this Attachment, **Serving Wire Center** is defined as the wire center owned by one Party from which the other Party would normally obtain dial tone for its Interconnection Point.

- 1.2.6 For the purposes of this Attachment, **Dedicated Interoffice Transport** is defined as a switch transport facility between the leasing Party's serving wire center and the Interconnection Point
- 1.3 **Fiber Meet**
- 1.3.1 **Fiber Meet** is an interconnection arrangement whereby the Parties physically interconnect their networks via an optical fiber interface (as opposed to an electrical interface) at which one Party's facilities, provisioning, and maintenance responsibility begins and the other Party's responsibility ends (i.e. Interconnection Point).
- 1.3.2 If Level 3 elects to interconnect with BellSouth pursuant to a Fiber Meet, Level 3 and BellSouth shall jointly engineer and operate a Synchronous Optical Network ("SONET") transmission system by which they shall interconnect their transmission and routing of Local Traffic and ISP-bound Traffic via a Local Channel facility at either the DS0, DS1, or DS3 level. The Parties shall work jointly to determine the specific transmission system. However, Level 3's SONET transmission must be compatible with BellSouth's equipment in the BellSouth Interconnection Wire Center. The same vendor's equipment and software version must be used, and the Data Communications Channel (DCC) must be turned off.
- 1.3.3 BellSouth shall, wholly at its own expense, procure, install and maintain the agreed upon SONET equipment in the BellSouth Interconnection Wire Center ("BIWC").
- 1.3.4 Level 3 shall, wholly at its own expense, procure, install and maintain the agreed upon SONET equipment in the Level 3 Interconnection Wire Center ("Level 3 Wire Center").
- 1.3.5 The Parties shall mutually designate an IP outside the BIWC as a Fiber Meet point and BellSouth shall make all necessary preparations to receive, and to allow and enable Level 3 to deliver, fiber optic facilities into the Interconnection Point with sufficient spare length to reach the fusion splice point at the Interconnection Point. BellSouth shall, wholly at its own expense, procure, install, and maintain the fusion splicing point in the Interconnection Point. A Common Language Location Identification ("CLLI") code will be established for each Interconnection Point. The code established must be a building type code. All orders shall originate from the Interconnection Point (i.e., Interconnection Point to Level 3, Interconnection Point to BellSouth).
- 1.3.6 Level 3 shall deliver and maintain such strands wholly at its own expense. Upon verbal request by Level 3, BellSouth shall allow Level 3 access to the Fiber Meet entry point for maintenance purposes as promptly as possible.

- 1.3.7 The Parties shall jointly coordinate and undertake maintenance of the SONET transmission system. Each Party shall be responsible for maintaining the components of their own SONET transmission system.
- 1.3.8 Each Party will be responsible for (i) providing its own transport facilities to the Fiber Meet, and (ii) the cost to build-out its facilities to such Fiber Meet.
- 1.3.9 Neither Party shall charge the other for its portion of the Fiber Meet facility used exclusively for non-transit Local Traffic and ISP-bound Traffic (i.e. the Local Channel). Charges incurred for other services including dedicated transport facilities will apply. Charges for Switched and Special Access Services shall be billed in accordance with the applicable Access Service tariff (i.e. the BellSouth Interstate or Intrastate Access Services Tariff).

2. **Interconnection Trunk Group Architectures**

- 2.1 BellSouth and Level 3 shall establish interconnecting trunk groups and trunk group configurations between networks including the establishment of one-way or two-way trunks in accordance with the following provisions set forth in this Agreement. For trunking purposes, traffic will be routed based on the digits dialed by the originating end user and in accordance with the Local Exchange Routing Guide (LERG).
- 2.2 Level 3 shall establish an interconnection trunk group(s) to at least one BellSouth access tandem within the LATA for the delivery of Level 3's originated Local Traffic, ISP-bound Traffic, and IntraLATA Toll Traffic and for the receipt and delivery of Transit Traffic. To the extent Level 3 desires to terminate Local Traffic, ISP-bound Traffic and IntraLATA Toll Traffic to BellSouth and Transit Traffic to third parties subtending other BellSouth access tandems within the LATA, other than the one Level 3 has established interconnection trunk groups to, Level 3 shall order Multiple Tandem Access, as described in this Attachment, to such other BellSouth access tandems or order interconnection trunk groups to such other BellSouth access tandems.
- 2.2.1 Notwithstanding the forgoing, Level 3 shall establish an interconnection trunk group(s) to all BellSouth access and local tandems in the LATA where Level 3 has homed (i.e. assigned) its NPA/NXXs. Level 3 shall home its NPA/NXXs on the BellSouth tandems that serve the Exchange Rate Center Areas to which the NPA/NXXs are assigned. The specified association between BellSouth tandems and Exchange Rate Centers is defined in the national Local Exchange Routing Guide (LERG). Level 3 shall enter its NPA/NXX access and/or local tandem homing arrangement into the LERG.
- 2.3 Switched Access traffic will be delivered to and by Interexchange Carriers (IXCs) based on Level 3's NXX Access Tandem homing arrangement as specified by Level 3 in the Local Exchange Routing Guide (LERG).
- 2.4 Any Level 3 interconnection request that deviates from the interconnection trunk group architectures as described in this Agreement that affects traffic delivered to

- Level 3 from a BellSouth switch that requires special BellSouth switch translations and other network modifications will require Level 3 to submit a Bona Fide Request/New Business Request via the Bona Fide Request/New Business Request Process set forth in General Terms and Conditions.
- 2.5 Except as otherwise provided in 1.2.1, charges, both non-recurring and recurring, associated with interconnecting trunk groups between BellSouth and Level 3 are set forth in Exhibit A. To the extent a rate associated with the interconnecting trunk group is not set forth in Exhibit A, the interim rate shall be as set forth in the appropriate BellSouth tariff for Switched Access services. Once a cost based rate is established by BellSouth, the interim tariff rate shall be trued up and the cost based rate will be applied retroactively to the effective date of this agreement.
- 2.6 All trunk groups will be provisioned as Signaling System 7 (SS7) capable where technically feasible. If SS7 is not technically feasible multi-frequency (MF) protocol signaling shall be used.
- 2.7 In cases where Level 3 is also an IXC, the IXC's Feature Group D (FG D) trunk group(s) must remain separate from the local interconnection trunk group(s).
- 2.8 Unless in response to a blocking situation or for a project, when either Party orders interconnection trunk group augmentations, a Firm Order Confirmation (FOC) shall be returned to the ordering Party within four (4) business days from receipt of a valid error free ASR. For local interconnection trunks, the party receiving an ASR will review each ASR for pre-order errors within two (2) business days of receipt. If an ASR contains an error, the Party receiving the ASR will notify the ordering Party of errors within two (2) business days of receipt. In order for the receiving Party to notify the ordering Party within the above specified timeframe, the ASR must be submitted to the correct ordering center. Furthermore, each Party has the obligation to ensure that the ordering system interfaces being used to receive rejected ASRs are functioning. Upon receipt of a request for clarification, each Party will submit a supplemental ASR within 48 hours to correct the specified errors. Each time a request for clarification is sent, the interval stops and does not restart until the specified error is resolved. A project is defined as a new trunk group or the request of 96 or more trunks on a single or multiple trunk group(s) in a given local calling area. Blocking situations and projects shall be managed through the BellSouth Interconnection Trunking Project Management group and Level 3's equivalent trunking group.
- 2.9 BellSouth will turn up orders for augmentation orders of ninety-six trunks or less within forty-five (45) calendar days of receipt of the order. The turn up dates for all other orders must be negotiated with BellSouth's Local Interconnection Switching Center (LISC) Project Management Group.

2.10 **Interconnection Trunk Groups for Exchange of Local, IntraLATA Toll and Transit Traffic**

2.10.1 If the Parties' originated Local Traffic and/or ISP-bound Traffic and/or IntraLATA Toll Traffic is utilizing the same two-way trunk group, the Parties shall mutually agree to use this type of two-way interconnection trunk group with the quantity of trunks being mutually determined and the provisioning being jointly coordinated. Furthermore, the Interconnection Point(s) for two-way interconnection trunk groups transporting both Parties Local Traffic and/or IntraLATA Toll shall be mutually agreed upon. Level 3 shall order such two-way trunks via the Access Service Request (ASR) process in place for Local Interconnection upon determination by the Parties, in a joint planning meeting, that such trunk groups shall be utilized. BellSouth will use the Trunk Group Service Request (TGSR) to request changes in trunking. Both Parties reserve the right to issue ASRs, if so required, in the normal course of business. Furthermore, the Parties shall jointly review such trunk performance and forecasts on a periodic basis. The Parties use of two-way interconnection trunk groups for the transport of Local Traffic and/or IntraLATA Toll traffic between the Parties does not preclude either Party from establishing additional one-way interconnection trunks for the delivery of its originated Local Traffic and/or IntraLATA Toll traffic to the other Party.

2.10.2 **BellSouth Access Tandem Interconnection Architectures**

BellSouth Access Tandem Interconnection provides intratandem access to subtending end offices. BellSouth Multiple Tandem Access (MTA), described later in this Agreement, may be ordered using any of the following access tandem architectures.

2.11.2.1 **Basic Architecture**

2.11.2.1.1 In this architecture, Level 3's originating Local Traffic and IntraLATA Toll Traffic and originating and terminating Transit Traffic is transported on a single two-way trunk group between Level 3 and BellSouth access tandem(s) within a LATA. This group carries intratandem Transit Traffic between Level 3 and Independent Companies, Interexchange Carriers, other CLECs and other network providers with which Level 3 desires interconnection and has the proper contractual arrangements as may be required with the third party. This group also carries Level 3 originated intertandem traffic transiting a single BellSouth access tandem destined to third party tandems such as an Independent Company tandem or other CLEC tandem. BellSouth originated Local Traffic, ISP-bound Traffic and IntraLATA Toll Traffic is transported on a single one-way trunk group terminating to Level 3. Other trunk groups for operator services, directory assistance, emergency services and intercept may be established if required. The LERG should be referenced for current routing and tandem serving arrangements. The Basic Architecture is illustrated in Exhibit B.

2.11.2.1 **One-Way Trunk Group Architecture**

2.11.2.3.1 In this architecture, the Parties interconnect using two one-way trunk groups. One one-way trunk group carries Level 3-originated Local Traffic, ISP-bound Traffic and IntraLATA Toll traffic destined for BellSouth end-users. The other one-way trunk group carries BellSouth-originated Local Traffic, ISP-bound Traffic and IntraLATA Toll traffic destined for Level 3 end-users. A third two-way trunk group is established for Level 3's originating and terminating Transit Traffic. This group carries intratandem Transit Traffic between Level 3 and Independent Companies, Interexchange Carriers, other CLECs and other network providers with which Level 3 desires interconnection and has the proper contractual arrangements as may be required with the third party. This group also carries Level 3 originated intertandem traffic transiting a single BellSouth access tandem destined to third party tandems such as an Independent Company tandem or other CLEC tandem. Other trunk groups for operator services, directory assistance, emergency services and intercept may be established if required. The LERG should be referenced for current routing and tandem serving arrangements. The One-Way Trunk Group Architecture is illustrated in Exhibit C.

2.11.2.2 Two-Way Trunk Group Architecture

2.11.2.2.1 The Two-Way Trunk Group Architecture establishes one two-way trunk group to carry Local Traffic, ISP-bound Traffic, and IntraLATA Toll traffic between Level 3 and BellSouth. In addition, a two-way transit trunk group must be established for Level 3's originating and terminating Transit Traffic. This group carries intratandem Transit Traffic between Level 3 and Independent Companies, Interexchange Carriers, other CLECs and other network providers with which Level 3 desires interconnection and has the proper contractual arrangements as may be required with the third party. This group also carries Level 3 originated intertandem traffic transiting a single BellSouth access tandem destined to third party tandems such as an Independent Company tandem or other CLEC tandem. Other trunk groups for operator services, directory assistance, emergency services and intercept may be established if required. The LERG should be referenced for current routing and tandem serving arrangements. The Two-Way Trunk Group Architecture is illustrated in Exhibit D.

2.11.2.3 Supergroup Architecture

2.11.2.3.1 In the Supergroup Architecture, the Parties Local Traffic, ISP-bound Traffic and IntraLATA Toll and Level 3's Transit Traffic are exchanged on a single two-way trunk group between Level 3 and BellSouth. This group carries intratandem Transit Traffic between Level 3 and Independent Companies, Interexchange Carriers, other CLECs and other network providers with which Level 3 desires interconnection and has the proper contractual arrangements as may be required with the third party. This group also carries Level 3 originated intertandem traffic transiting a single BellSouth access tandem destined to third party tandems such as an Independent Company tandem or other CLEC tandem. Other trunk groups for operator services, directory assistance, emergency services and intercept may be

established if required. The LERG should be referenced for current routing and tandem serving arrangements. The Supergroup Architecture is illustrated in Exhibit E.

2.11.3 Multiple Tandem Access Service

- 2.11.3.1 Upon request, BellSouth will provide Level 3 with **Multiple Tandem Access (MTA)**, which provides for LATA wide BellSouth transport and termination of Level 3-originated IntraLATA Toll, ISP-bound Traffic and Local Traffic, that is transported by BellSouth, by establishing an interconnection trunk group(s) at a BellSouth access tandem with routing through multiple BellSouth access tandems as required. However, Level 3 must still establish an interconnection trunk group(s) at all BellSouth access tandems where Level 3 NXXs are “homed”. If Level 3 does not have NXXs homed at a BellSouth access tandem within a LATA and elects not to establish an interconnection trunk group(s) at such BellSouth access tandem, Level 3 can order MTA in each BellSouth access tandem within the LATA where it does have an interconnection trunk group(s) and BellSouth will terminate traffic to end-users served through those BellSouth access tandems where Level 3 does not have an interconnection trunk group(s). MTA shall be provisioned in accordance with BellSouth’s Ordering Guidelines.
- 2.11.3.2 MTA does not include switched access traffic that transits the BellSouth network to an Interexchange Carrier (IXC). Switched Access traffic will be delivered to and by IXCs based on Level 3’s NXX Access Tandem homing arrangement as specified by Level 3 in the national Local Exchange Routing Guide (LERG).
- 2.11.3.3 For Level 3 originated Local Traffic, ISP-bound Traffic, and IntraLATA Toll traffic that BellSouth transports but is destined for termination by third Party network (Transit Traffic), BellSouth MTA is required if multiple BellSouth access tandems are necessary to deliver the call to the third Party network.
- 2.11.3.4 With MTA, for the delivery of Level 3’s originating Local Traffic, IntraLATA Toll, and ISP-bound Traffic, Level 3 will be assessed charges as specified in the pricing exhibit to this Agreement for the additional transport and tandem switching on an elemental basis in addition to the reciprocal compensation rate to which the parties have agreed in Section 5.1.2. Notwithstanding the foregoing, in the situation of tandem exhaust at any particular tandem, where the parties choose MTA as an alternative routing plan, the Parties will negotiate appropriate rates, terms and conditions for MTA.
- 2.11.3.5 To the extent Level 3 does not purchase MTA in a calling area that has multiple access tandems serving the calling area as defined by BellSouth, Level 3 must establish an interconnection trunk group(s) to every access tandem in the calling area in order to serve the entire calling area. To the extent Level 3 does not purchase MTA and provides IntraLATA Toll service to its customers, it may be necessary for it to establish an interconnection trunk group(s) to additional

BellSouth access tandems that serve end offices outside the local calling area. To the extent Level 3 routes its traffic in such a way that utilizes BellSouth's MTA service without properly ordering MTA service, Level 3 agrees to pay BellSouth the associated transport and termination charges.

- 2.11.3.6 Nothing in this Section 2.11 affects either Party's obligation to deliver its originated traffic to the Interconnection Point(s) established pursuant to Section 1.

2.11.4 Local Tandem Interconnection

- 2.11.4.1** Local Tandem Interconnection arrangement allows Level 3 to establish an interconnection trunk group(s) at BellSouth local tandems for: (1) the delivery of Level 3-originated Local Traffic transported and terminated by BellSouth to BellSouth end offices within the local calling area as defined in BellSouth's General Subscriber Services Tariff (GSST), section A3 served by those BellSouth local tandems, and (2) for Local Transit Traffic transported by BellSouth for third party network providers who have also established an interconnection trunk group(s) at those BellSouth local tandems.

- 2.11.4.2 When a specified local calling area is served by more than one BellSouth local tandem, Level 3 must designate a "home" local tandem for each of its assigned NPA/NXXs and establish trunk connections to such local tandems. Additionally, Level 3 may choose to establish an interconnection trunk group(s) at the BellSouth local tandems where it has no codes homing but is not required to do so. Level 3 may deliver Local Traffic to a "home" BellSouth local tandem that is destined for other BellSouth or third party network provider end offices subtending other BellSouth local tandems in the same local calling area where Level 3 does not choose to establish an interconnection trunk group(s). It is Level 3's responsibility to enter its own NPA/NXX local tandem homing arrangements into the Local Exchange Routing Guide (LERG) either directly or via a vendor in order for other third party network providers to determine appropriate traffic routing to Level 3's codes. Likewise, Level 3 shall obtain its routing information from the LERG.

- 2.11.4.3 Notwithstanding establishing an interconnection trunk group(s) to BellSouth's local tandems, Level 3 must also establish an interconnection trunk group(s) to BellSouth access tandems within the LATA on which Level 3 has NPA/NXXs homed for the delivery of Interexchange Carrier Switched Access (SWA) and toll traffic, and traffic to Type 2A CMRS connections located at the access tandems. BellSouth shall not switch SWA traffic through more than one BellSouth access tandem. SWA, Type 2A CMRS or toll traffic routed to the local tandem in error will not be backhauled to the BellSouth access tandem for completion. (Type 2A CMRS interconnection is defined in BellSouth's A35 General Subscriber Services Tariff).

- 2.11.4.4 BellSouth's provisioning of local tandem interconnection assumes that Level 3 has local interconnection agreements, where they may be required, with the other third party network providers subtending those local tandems.

2.11.5 Direct End Office-to-End Office Interconnection

- 2.11.5.1 Direct End Office-to-End Office one-way or two-way interconnection trunk groups allow for the delivery of a Party's originating local or IntraLATA Toll traffic to the terminating Party on a direct end office-to-end office basis.
- 2.11.5.2 The Parties shall utilize direct end office-to-end office trunk groups under the following conditions:
- 2.11.5.2.1 Tandem Exhaust - If a tandem through which the Parties are interconnected is unable to, or is forecasted to be unable to support additional traffic loads for any period of time, the Parties will mutually agree on an end office trunking plan that will alleviate the tandem capacity shortage and ensure completion of traffic between Level 3 and BellSouth's subscribers.
- 2.11.5.2.2 Traffic Volume –To the extent either Party has the capability to measure the amount of traffic between a Level 3 switching center and a BellSouth end office, either Party shall install and retain direct end office trunking sufficient to handle actual or reasonably forecasted traffic volumes, whichever is greater, between a Level 3 switching center and a BellSouth end office where the traffic exceeds or is forecasted to exceed a single DS1 of Local Traffic during the time consistent busy hour (as measured utilizing the day-to-day variation and peakedness) per month over a period of three (3) consecutive months. Either Party will install additional capacity between such points when overflow traffic between Level 3's switching center and BellSouth's end office exceeds or is forecasted to exceed a single DS1 of Local Traffic during the time consistent busy hour (measured utilizing the day-to-day variation and peakedness) per month. In the case of one way trunking, additional trunking shall only be required by the Party whose trunking has achieved the preceding usage threshold.
- 2.11.5.2.3 Mutual Agreement - The Parties may install direct end office trunking upon mutual agreement in the absence of conditions (1) or (2) above and agreement will not unreasonably be withheld.

2.11.6 Transit Traffic Trunk Group

- 2.11.6.1 Transit Traffic trunks can either be two-way trunks or two one-way trunks ordered by Level 3 to deliver and receive Local Traffic, ISP-bound Traffic, and IntraLATA Toll Transit Traffic from third parties, such as Independent Companies and other CLECs, via BellSouth access tandems (or BellSouth local tandems for Local Traffic), and Switched Access traffic to and from Interexchange Carriers via BellSouth access tandems pursuant to the Transit Traffic section of this

Attachment. Establishing Transit Traffic trunks at BellSouth access and local tandems provides intratandem access to the third parties also interconnected at those tandems.

2.11.7 Toll Free Traffic

- 2.11.7.1 If Level 3 chooses BellSouth to handle Toll Free database queries from its switches, all Level 3 originating Toll Free traffic will be routed over the Transit Traffic Trunk Group.
- 2.11.7.2 All originating Toll Free Service (Toll Free) calls for which Level 3 requests that BellSouth perform the Service Switching Point (“SSP”) function (i.e., perform the database query) shall be delivered using GR-394 format over the Transit Traffic Trunk Group. Carrier Code “0110” and Circuit Code (to be determined for each LATA) shall be used for all such calls.
- 2.11.7.3 Level 3 may handle its own Toll Free database queries from its switch. If so, Level 3 will determine the nature (Local Traffic/IntraLATA/InterLATA Traffic) of the Toll Free call based on the response from the database. If the query determines that the call is a BellSouth local or intraLATA Toll Free number, Level 3 will route the post-query Local Traffic or IntraLATA converted ten-digit local number to BellSouth over the local or intraLATA trunk group. If the query determines that the call is a third party (ICO or other CLEC) local or intraLATA Toll Free number, Level 3 will route the post-query local or intraLATA converted ten-digit local number to BellSouth over the Transit Traffic Trunk Group. In such case, Level 3 is to provide a Toll Free billing record when appropriate. If the query reveals the call is an interLATA Toll Free number, Level 3 will route the post-query interLATA call (Toll Free number) directly from its switch for carriers interconnected with its network or over the Transit Traffic Trunk Group to carriers not directly connected to its network but are connected to BellSouth’s access tandem. Calls will be routed to BellSouth over the Local /IntraLATA Traffic and Transit Traffic Trunk Groups within the LATA in which the calls originate.
- 2.11.7.4 All post-query Toll Free Service (Toll Free) calls for which Level 3 performs the SSP function, if delivered to BellSouth, shall be delivered using GR-394 format for calls destined to IXCs, and GR-317 format for calls destined to end offices that directly subtend the BellSouth access tandem.

3. Network Design And Management For Interconnection

- 3.1 Network Management and Changes. Both Parties will work cooperatively with each other to install and maintain the most effective and reliable interconnected telecommunications networks, including but not limited to, the exchange of toll-free maintenance contact numbers and escalation procedures. Both Parties agree to

- provide public notice of changes in the information necessary for the transmission and routing of services using its local exchange facilities or networks, as well as of any other changes that would affect the interoperability of those facilities and networks. Notice of such changes shall be provided in accordance with FCC or Commission rules or industry standards, as applicable. For changes which impact service to end users, BellSouth will work cooperatively with Level 3 to address such changes.
- 3.2 Interconnection Technical Standards. The interconnection of all networks will be based upon accepted industry/national guidelines for transmission standards and traffic blocking criteria. Interconnecting facilities shall conform, at a minimum, to the telecommunications industry standard of DS-1 pursuant to Bellcore Standard No. TR-NWT-00499. Signal transfer point, Signaling System 7 (“SS7”) connectivity is required at each interconnection point. BellSouth will provide out-of-band signaling using Common Channel Signaling Access Capability where technically and economically feasible, in accordance with the technical specifications set forth in the BellSouth Guidelines to Technical Publication, TR-TSV-000905. Facilities of each Party shall provide the necessary on-hook, off-hook answer and disconnect supervision and shall hand off calling number ID (Calling Party Number) when technically feasible.
- 3.3 Quality of Interconnection. The local interconnection for the transmission and routing of telephone exchange service and exchange access that each Party provides to each other will be at least equal in quality to what it provides to itself and any subsidiary or affiliate, where technically feasible, or to any other Party to which each Party provides local interconnection.
- 3.4 Network Management Controls. Both Parties will work cooperatively with each other to apply sound network management principles by invoking appropriate network management controls (e.g., call gapping) to alleviate or prevent network congestion.
- 3.5 Common Channel Signaling. Both Parties will provide LEC-to-LEC Common Channel Signaling (“CCS”) to each other, where available, in conjunction with all traffic in order to enable full interoperability of CLASS features and functions except for call return. All CCS signaling parameters will be provided, including automatic number identification (“ANI”), originating line information (“OLI”) calling company category, charge number, etc. All privacy indicators will be honored, and each Party will cooperate with each other on the exchange of Transactional Capabilities Application Part (“TCAP”) messages to facilitate full interoperability of CCS-based features between the respective networks. Neither Party shall alter the CCS parameters, or be a party to altering such parameters, or knowingly pass CCS parameters that have been altered in order to circumvent appropriate interconnection charges.
- 3.6 Signaling Call Information. BellSouth and Level 3 will send and receive 10 digits for Local Traffic. Additionally, BellSouth and Level 3 will exchange the proper call

information, i.e. originated call company number and destination call company number, CIC, and OZZ, including all proper translations for routing between networks and any information necessary for billing.

3.7 **Non-binding Forecasting for Trunk Provisioning**

3.7.1 Within six (6) months after execution of this agreement, and each quarter thereafter, Level 3 shall provide an interconnection trunk group forecast for each LATA that it shall provide service within BellSouth's region. Upon receipt of Level 3's forecast, the Parties shall schedule and participate in a joint planning meeting to develop a joint interconnection trunk group forecast. Each forecast provided under this Section shall be deemed "Confidential Information" under the General Terms and Conditions – Part A of this Agreement.

3.7.1.1 At a minimum, the forecast shall include the projected quantity of Transit Trunks, Level 3-to-BellSouth one-way trunks ("Level 3 Trunks"), BellSouth-to-Level 3 one-way trunks ("Reciprocal Trunks") and/or two-way interconnection trunks, if the Parties have agreed to interconnect using two-way trunking to transport the Parties' Local Traffic, ISP-bound Traffic, and IntraLATA Toll. The quantities shall be projected for a minimum of six months in advance and shall include the current year plus next two years total forecasted quantities. Considering Level 3's provided forecast, the Parties shall mutually develop Reciprocal Trunk and/or two-way interconnection trunk forecast quantities for the time periods listed and to be included within the initial forecast.

3.7.1.2 Additionally all forecasts shall include, at a minimum, Access Carrier Terminal Location ("ACTL"), trunk group type (Local Traffic/IntraLATA Toll, Transit, Operator Services, 911, etc.), A location/Z location (CLLI codes for Level 3 location and BellSouth location where the trunks shall terminate), interface type (e.g., DS1), Direction of Signaling, Trunk Group Number, if known, (commonly referred to as the 2-6 code) and forecasted trunks in service each year (cumulative).

3.7.1.3 At Level 3's specific written or electronic mail request to provide the information identified in this section, BellSouth shall provide Level 3 written confirmation that it has received Level 3's forecasts and included such information in its own network planning. As part of this confirmation, BellSouth shall also provide Level 3 with a description of major network projects anticipated within the following six (6) months that could affect its ability to respond to Level 3's forecasts. Major network projects include trunking or network rearrangements, anticipated tandem exhaust, anticipated end office exhaust, or other activities that are reflected by a significant increase or decrease in trunking demand over that six (6) month period. BellSouth will also provide, as part of this confirmation, notice of any network expansions, software and hardware upgrades, and other network changes that are likely to preclude BellSouth from completing trunk orders submitted by Level 3 during that six (6) month period.

- 3.7.2 Each Party shall exercise its best efforts to provide the quantity of interconnection trunks mutually forecasted. However, the provision of the forecasted quantity of interconnection trunks is subject to trunk terminations and facility capacity existing at the time the trunk order is submitted. Furthermore, the receipt and development of trunk forecasts does not imply any liability for failure to perform if capacity (trunk terminations or facilities) is not available for use at the forecasted time.
- 3.7.3 The submitting and development of interconnection trunk forecasts shall not replace the ordering process in place for local interconnection trunks.
- 3.7.4 Once initial interconnection trunk forecasts have been developed, Level 3 shall continue to provide interconnection trunk forecasts on a quarterly basis or at otherwise mutually agreeable intervals. Level 3 shall use its best efforts to make the forecasts as accurate as possible based on reasonable engineering criteria. Interconnection trunk forecasts shall be updated and provided to BellSouth on an as needed basis, but no less frequently than quarterly and no more frequently than monthly. Upon receipt of Level 3's forecast, including forecast updates, the Parties shall confer to mutually develop BellSouth Reciprocal Trunk and/or two-way interconnection trunk forecasted quantities for the listed time periods within such subsequent forecasts.

3.8 Trunk Utilization

- 3.8.1 During the first month of each calendar quarter, Level 3 shall provide a forecast pursuant to Section 3.7 which sets forth in good faith Level 3's trunking requirements for the quarter following the quarter during which the forecast is provided. Each forecast will set forth with specificity, in accordance with the requirements of Section 3.7.1.2, the forecast for each LATA within BellSouth's territory within which Level 3 provides service, or plans to provide service. Subject to Section 3.7.2, where such forecasts are provided as specified in this Section, BellSouth shall use its best efforts to order, or to provide based upon Level 3's orders, the designated number of trunks at locations identified by Level 3 within the time frames specified by Level 3. Nothing in this Section shall be construed as a guarantee on the part of BellSouth that trunks will be made available pursuant to Level 3's forecasts.
- 3.8.2 BellSouth and Level 3 shall monitor traffic on each interconnection trunk group that is installed pursuant to the initial interconnection trunk requirements and subsequent quarterly forecasts. At any time after the end of a calendar quarter, based on a review of the capacity utilization during such quarter for installed Reciprocal Trunk groups and/or two-way interconnection trunk groups, subject to the provisions of this Section 3.8, after fifteen (15) business days advance written notice to Level 3, BellSouth may disconnect any Underutilized Reciprocal Trunk(s) and/or request Level 3 to disconnect any Underutilized two-way interconnection trunk(s) if BellSouth has determined that the trunk group is not being utilized at eighty-five percent (85%) during the time consistent busy hour utilization level over a three (3) month period (utilizing the day-to-day variation and

peakedness), provided that the Parties have not otherwise agreed. Underutilized trunks are defined as the trunks not being utilized as a result of a time consistent busy hour utilization of less than 85% (using the day-to-day variation and peakedness on the given trunk group).

- 3.8.3 To the extent that BellSouth has not ordered or provided, as applicable, trunks in the amount specified by Level 3 in each quarterly forecast within the time frame specified in that forecast within a given LATA, the utilization requirements set forth in Section 3.8.2 for determining whether a trunk group is Underutilized shall not apply to trunks ordered or provided pursuant to that quarterly forecast until such time as all trunks (or equivalent capacity at the tandem subtended by the end office in which the shortfall in trunks has occurred) are ordered or provided by BellSouth, as applicable, pursuant to that quarter's Level 3 forecast. If, however, BellSouth's failure to order or provide, as applicable, the forecasted amount of trunks in a LATA in a given quarter is caused by Level 3's inability to accept such trunks, Level 3 shall be held to the utilization requirements set forth in Section 3.8.2 for the trunk groups in that LATA ordered or provided pursuant to that quarterly forecast. In the event that BellSouth fails to order or provide, as applicable, trunks in the amount specified by Level 3 in its quarterly forecast within the time frames specified in that forecast within a given LATA, and Level 3 is also unable to accept the trunks specified in its quarterly forecast during that quarter, the utilization requirements set forth in Section 3.8.2 for determining whether a trunk group is Underutilized shall not apply to trunk groups in that LATA ordered or provided pursuant to that quarterly forecast until such time as all trunks (or equivalent capacity at the tandem subtended by the end office in which the shortfall in trunks has occurred) are ordered or provided by BellSouth, as applicable, pursuant to that quarter's Level 3 forecast.
- 3.8.4 Each quarter's forecasted amount of trunks shall be measured independently for purposes of identifying Underutilized trunks pursuant to Section 3.8.2. Level 3's ability to forecast and obtain trunks in each quarter shall be independent of any utilization requirements applied to trunks ordered or provided during prior quarters or trunks ordered or provided additional to the quarterly forecasted amounts. To the extent that Level 3 asks BellSouth to order or provide additional trunks (other than those specified in each quarter's forecasts as provided by Level 3), BellSouth shall measure such additional trunks independently of any quarterly forecasts to determine whether such additional trunks are Underutilized pursuant to the terms of Section 3.8.2. The provisions of Section 3.8.3 shall not apply to such additional trunks that are not specified in the Level 3 quarterly forecast.
- 3.8.5 Within ten (10) business days following the disconnection notice prescribed in Section 3.8.2 above, Level 3 may request that BellSouth not disconnect or not request disconnection for some or all of the Underutilized Trunks, in which event BellSouth shall keep the trunks in service and may invoice Level 3 for, and Level 3 shall pay, all applicable recurring and nonrecurring trunk and facility unbundled network element charges for the Underutilized Trunks. The charges shall be applied from the date of the disconnection notice and continue until such trunks are disconnected, or to the extent Level 3 requests that such trunks remain in service, until the trunk group reaches an eighty-five percent

(85%) time-consistent busy hour utilization level (using the day-to-day variation and peakedness on the given trunk group). In addition, Level 3 shall reimburse BellSouth for any nonrecurring and/or recurring charges BellSouth may have paid to Level 3 for the Underutilized Trunks and for any trunk installation expense BellSouth incurred. This expense shall equal the nonrecurring installation charge for trunks in Exhibit A. Furthermore, the Level 3 forecasts for each subsequent forecast period shall be automatically reduced by the number of Reciprocal Trunks and/or two-way interconnection trunks that have been determined to be subject to disconnection pursuant to the foregoing procedures.

4. **Local Dialing Parity**

4.1 BellSouth and Level 3 shall provide local and toll dialing parity to each other with no unreasonable dialing delays. Dialing parity shall be provided for all originating telecommunications services that require dialing to route a call. BellSouth and Level 3 shall permit similarly situated telephone exchange service end users to dial the same number of digits to make a local telephone call notwithstanding the identity of the end user's or the called party's telecommunications service provider.

5. **Interconnection Compensation**

5.1 **Compensation for Call Transportation and Termination for Local Traffic and Inter-Carrier Compensation for ISP-Bound Traffic**

5.1.1 For reciprocal compensation between the Parties pursuant to this Attachment, Local Traffic is defined as any telephone call that is originated by an end user of one Party and terminated to an end user of the other Party within a given LATA on that other Party's network, except for those calls that are originated or terminated through switched access arrangements as established by the ruling regulatory body. Nothing in this Agreement shall be construed to limit either Party's ability to designate the areas within which the Party's customers may make calls which that Party rates as "local" in its customer tariffs.

5.1.2. Subject to the Parties' agreement to the terms of Sections 1.1.1 through 1.1.1.2, 1.2.1, 2.11.3.4, and 5.1 through 5.1.7, the Parties will compensate each other on a mutual and reciprocal basis for the transport and termination of Local Traffic at the following rates:

1/1/01 – 12/31/01	\$.00175 per MOU
1/1/02 – 12/31/02	\$.00150 per MOU
1/1/03 – 12/31/03	\$.00100 per MOU

Notwithstanding anything to the contrary in any prior agreement of the Parties, the compensation set forth in this Section shall not be paid retroactively to the expiration date of the Parties' prior interconnection agreement. The Parties recognize and agree that they negotiated these annual rates together as a complete rate structure to apply over the full term of this Agreement and that the Parties would not have mutually agreed to accept a single annual rate in any single year. Nothing in this Paragraph shall limit Level 3's rights pursuant to Section 5.1.3.3.

5.1.3 The Parties have been unable to agree upon whether dial-up calls to Information Service Providers ("ISPs") should be considered Local Traffic for purposes of this Agreement. ISP-bound Traffic is defined as dial-up calls to an ISP dialed using a local dialing pattern (7 or 10 digits) by the calling party to an ISP server (e.g., a modem bank) located in the LATA. However, without prejudice to either Party's position concerning the application of reciprocal compensation to ISP-bound Traffic, the Parties agree for purposes of this Agreement only to compensate each other for the delivery of ISP-bound Traffic at the same per minute of use rates set forth in Section 5.1.2. No switched access charges will be assessed in connection with ISP-bound Traffic as defined in this Section. It is expressly understood and agreed that this inter-carrier compensation mechanism for ISP-bound Traffic is being established: (1) in consideration for a waiver and release by each party for any and all claims for reciprocal compensation for ISP-bound Traffic exchanged between the parties prior to expiration of their predecessor interconnection agreements, which is hereby given; and (2) subject to the terms and conditions in Sections 1.1.1 through 1.1.1.2, 1.2.1, 2.11.3.4, and 5.1 through 5.1.7.

5.1.3.1 Notwithstanding any change in law provisions to the contrary, the inter-carrier compensation mechanism established in Section 5.1.3 shall continue at the rates set forth in Section 5.1.2 for the full term of this Agreement, except as provided for in this Section 5.1.3.1 and in Section 5.1.3.2. The Parties recognize and agree that the FCC, courts of competent jurisdiction, or state commissions with jurisdiction over the Parties will issue subsequent decisions on inter-carrier compensation mechanisms on a generic basis (i.e., a decision that is expressly applicable to all carriers generally) for ISP-bound Traffic ("Subsequent Decisions"). Once such a Subsequent Decision is effective, either Party may request to renegotiate this Agreement with respect to the payment of compensation for ISP-bound Traffic. The Party receiving the request to renegotiate has thirty business days to choose, at its sole discretion, one of the following options: (1) to accept the compensation mechanism set forth in the Subsequent Decision and apply such mechanism to the remainder of the term of this Agreement, or (2) to choose to amend this Agreement to compensate all Local Traffic and ISP-bound Traffic at the rate of \$.001 per minute of use for the remainder of the term of this Agreement. Understanding that Sections 1.1.1 through 1.1.1.2, 1.2.1, and 2.11.3.4, and 5.1 through 5.1.7 are interrelated, the Parties agree they will renegotiate the terms set forth in all these Sections in the event that the receiving Party chooses option (1). Whichever choice the receiving party makes shall become effective three months after the Subsequent Decision is effective. In the event of such an amendment, there will be no true-up for compensation paid prior to the effective date of the amendment.

- 5.1.3.2 To the extent such Subsequent Decisions render the inter-carrier compensation mechanism for ISP-bound Traffic set forth in Section 5.1.3 in violation of applicable federal or state law (e.g., the mechanism described herein is prohibited by law), the Parties agree to amend this Agreement within thirty (30) days of the effective date of any such Subsequent Decision to conform the inter-carrier compensation mechanism set forth in Section 5.1.3 with such Subsequent Decision. In the event of such an amendment, there will be no true-up for compensation paid prior to the effective date of the amendment. Understanding that Sections 1.1.1 through 1.1.1.2, 1.2.1, and 2.11.3.4, and 5.1 through 5.1.7 are interrelated, the Parties agree they will renegotiate the terms set forth in all these Sections in the event that such Subsequent Decisions render the inter-carrier compensation mechanism for ISP-bound Traffic set forth in Section 5.1.3 in violation of applicable federal or state law.
- 5.1.3.3 Nothing herein shall preclude Level 3 from exercising its rights under this Agreement or Section 252(i) of the 1996 Act and applicable FCC regulations to elect rates, terms, and conditions with respect to the payment of reciprocal compensation or other form of inter-carrier compensation from any other approved interconnection agreement executed by BellSouth under which BellSouth is paying reciprocal compensation or other form of inter-carrier compensation for ISP-bound Traffic other than on an interim basis. The Parties recognize and agree that this provision is intended to ensure that Level 3 is treated in the same manner with respect to the payment of reciprocal compensation or inter-carrier compensation for ISP-bound Traffic as the competing local exchange carrier from whose interconnection agreement Level 3 seeks to elect rates, terms, and conditions. Accordingly, Level 3 agrees that it will not seek to elect reciprocal compensation or inter-carrier compensation rates, terms, or conditions from another interconnection agreement unless those rates, terms, and conditions apply to ISP-bound Traffic (other than on an interim basis), either by the express terms of that agreement, by voluntary action by BellSouth, or pursuant to an effective FCC or state commission or court order.
- 5.1.4 Local Traffic does not include, and the Parties shall not bill or pay reciprocal compensation for, calls where a Party willfully sets up a call, or colludes with a third party to set up a call, to the other Party's network for the primary purpose of receiving reciprocal compensation, and not for the purpose of providing a telecommunications service to an End User in good faith.
- 5.1.5 Neither Party shall represent Switched Access Traffic as Local Traffic for purposes of payment of reciprocal compensation.
- 5.1.6 The Parties have been unable to agree as to the appropriate compensation for calls which originate in a LATA and terminate to a physical location outside of that LATA but to a number assigned to a rate center within that LATA. However, without prejudice to either Party's position concerning the application of reciprocal compensation or access charges to such traffic, the Parties agree for purposes of this Agreement only and subject to the Parties' agreement to the terms of Sections 1.1.1 through 1.1.1.2, 1.2.1, 2.11.3.4, and

Sections 5.1 – 5.7 and on an interim basis until the FCC issues an Order addressing this issue, neither Party shall bill the other reciprocal compensation, inter-carrier compensation or switched access in connection with the exchange of any traffic as described in the first sentence of this paragraph. Once the FCC issues an Effective Order addressing this issue, the Parties agree to amend this Interconnection Agreement to comply with the Order on a prospective basis only within 30 days of either Party's written request. No "true-up" shall be required in connection with such an Effective Order. Nothing in this Section 5.1.6 affects the obligations imposed on the Parties pursuant to Sections 5.1.1, 5.1.2, and 5.1.3 to compensate each other for Local Traffic and ISP-bound Traffic as those terms are defined therein.

- 5.1.7 **Compensation for Trunks and Associated Facilities.** Compensation for trunks and associated facilities will be handled in accordance with Section 1.2.1.
- 5.2 **Percent Local Use.** Each Party shall report to the other a Percent Local Usage ("PLU"). The application of the PLU will determine the amount of Local Traffic and ISP-bound Traffic minutes to be billed to the other Party. For purposes of developing the PLU, each Party shall consider every local call, ISP-bound call, and every long distance call, excluding Transit Traffic. Each Party shall update its PLU on the first of January, April, July and October of the year and shall send it to the other Party to be received no later than 30 calendar days after the first of each such month based on local usage for the past three months ending the last day of December, March, June and September, respectively. Requirements associated with PLU calculation and reporting shall be as set forth in BellSouth's Percent Local Use Reporting Guidebook, as it is amended from time to time. Notwithstanding the foregoing, where the terminating Party has message recording technology that identifies the jurisdiction of traffic terminated as defined in this Agreement, such information, in lieu of the PLU factor, shall at the terminating Party's option be utilized to determine the appropriate local usage compensation to be paid. The Parties recognize that there is a disagreement regarding the nature of ISP-bound traffic as stated in Section 5.1.3. Notwithstanding the foregoing, for purposes of this Agreement only and without prejudice to either Party's position, the Parties agree to include minutes of use for ISP-bound Traffic as defined in Section 5.1.3 in the Percent Local Usage Factor.
- 5.3 **Percent Local Facility.** Each Party shall report to the other a Percent Local Facility ("PLF"). The application of the PLF will determine the portion of switched dedicated transport to be billed per the local jurisdiction rates. The PLF shall be applied to multiplexing, local channel and interoffice channel switched dedicated transport utilized in the provision of local interconnection trunks. Each Party shall update its PLF on the first of January, April, July and October of the year and shall send it to the other Party to be received no later than 30 calendar days after the first of each such month to be effective the first bill period the following month, respectively. Requirements associated with PLU and PLF calculation and reporting shall be as set

forth in BellSouth's Percent Local Use/Percent Local Facility Reporting Guidebook, as it is amended from time to time.

- 5.4 **Percent Interstate Usage.** Each Party shall report to the other the projected Percent Interstate Usage ("PIU"). All jurisdictional report requirements, rules and regulations for Interexchange Carriers specified in BellSouth's Intrastate Access Services Tariff will apply to Level 3. After interstate and intrastate traffic percentages have been determined by use of PIU procedures, the PLU and PLF factors will be used for application and billing of local interconnection. Each Party shall update its PIUs on the first of January, April, July and October of the year and shall send it to the other Party to be received no later than 30 calendar days after the first of each such month, for all services showing the percentages of use (PIUs, PLU, and PLF) for the past three months ending the last day of December, March, June and September.
- 5.5 **Audits.** On thirty (30) days written notice, each Party must provide the other the ability and opportunity to conduct an annual audit to ensure the proper billing of traffic. BellSouth and Level 3 shall retain records of call detail for a minimum of nine months from which a PLU, PLF and/or PIU can be ascertained. The audit shall be accomplished during normal business hours at an office designated by the Party being audited. Audit requests shall not be submitted more frequently than one (1) time per calendar year. Audits shall be performed by a mutually acceptable independent auditor paid for by the Party requesting the audit, and be conducted pursuant to the confidentiality provisions of this Agreement. The PLU, PLF and/or PIU shall be adjusted based upon the audit results and shall apply to the usage for the quarter the audit was completed, to the usage for the quarter prior to the completion of the audit, and to the usage for the two quarters following the completion of the audit. If, as a result of an audit, either Party is found to have overstated the PLU, PLF and/or PIU by twenty percentage points (20%) or more, that Party shall reimburse the auditing Party for the cost of the audit.

5.6 **Rate True-up**

This section applies only to Tennessee and other rates that are interim or expressly subject to true-up under this attachment.

5.6.1 The interim prices for Unbundled Network Elements and Other Services and Local Interconnection shall be subject to true-up according to the following procedures:

5.6.2 The interim prices shall be true-up, either up or down, based on final prices determined either by further agreement between the Parties, or by a final order (including any appeals) of the Commission which final order meets the criteria of Section 5.6.4 below. The Parties shall implement the true-up by comparing the actual volumes and demand for each item, together with interim prices for each item, with the final prices determined for each item. Each Party shall keep its own records upon which the true-up can be based, and any final payment from one Party to the other shall be in an amount agreed upon by the Parties based on such records. In the event of any disagreement as between the records or the Parties regarding the amount of such true-up, the

Parties agree that the body having jurisdiction over the matter shall be called upon to resolve such differences, or the Parties may mutually agree to submit the matter to the Dispute Resolution process in accordance with the provisions of Section 12 of the General Terms and Conditions and Attachment 1 of the Agreement.

5.6.3 The Parties may continue to negotiate toward final prices, but in the event that no such agreement is reached within nine (9) months, either Party may petition the Commission to resolve such disputes and to determine final prices for each item. Alternatively, upon mutual agreement, the Parties may submit the matter to the Dispute Resolution Process set forth in the General Terms and Conditions of the Agreement, so long as they file the resulting Agreement with the Commission as a “negotiated agreement” under Section 252(e) of the Act.

5.6.4 A final order of this Commission that forms the basis of a true-up shall be the final order as to prices based on appropriate cost studies, or potentially may be a final order in any other Commission proceeding which meets the following criteria:

- (a) BellSouth and CLEC are entitled to be full Parties to the proceeding; and
- (b) It shall apply the provisions of the federal Telecommunications Act of 1996, including but not limited to Section 252(d)(1) (which contains pricing standards) and all then-effective implementing rules and regulations.

5.7 **Compensation for IntraLATA Toll and 8XX Traffic**

5.7.1 IntraLATA Toll Traffic. IntraLATA Toll Traffic is defined as any telephone call that is not local, ISP-bound traffic (As defined in Section 5.1.3) or switched access per this Agreement.

5.7.2 Compensation for IntraLATA Toll traffic. For terminating its IntraLATA Toll traffic on the other company’s network, the originating Party will pay the terminating Party that party’s current and effective Commission- or FCC-filed intrastate or interstate, whichever is appropriate, terminating switched access tariff rates as set forth in BellSouth’s or Level 3’s Intrastate or Interstate Access Services Tariff. The appropriate charges will be determined by the routing of the call. If Level 3 is the BellSouth end user’s presubscribed interexchange carrier or if the BellSouth end user uses Level 3 as an interexchange carrier on a 101XXXX basis, BellSouth will charge Level 3 the appropriate BellSouth tariff charges for originating switched access services.

5.7.3 Compensation for 8XX Traffic. Each Party shall compensate the other pursuant to the appropriate switched access charges, including the database query charge as set forth in the BellSouth intrastate or interstate switched access tariffs.

- 5.7.4 Records for 8XX Billing. Each Party will provide to the other the appropriate records necessary for billing intraLATA 8XX customers. The records provided will be in a standard EMI format.
- 5.7.5 8XX Access Screening. BellSouth's provision of 8XX TFD to Level 3 requires interconnection from Level 3 to BellSouth 8XX SCP. Such interconnections shall be established pursuant to BellSouth's Common Channel Signaling Interconnection Guidelines and Bellcore's CCS Network Interface Specification document, TR-TSV-000905. Level 3 shall establish CCS7 interconnection at the BellSouth Local Signal Transfer Points serving the BellSouth 8XX SCPs that Level 3 desires to query. The terms and conditions for 8XX TFD are set out in BellSouth's Intrastate Access Services Tariff as amended.

5.8 Mutual Provision of Switched Access Service

- 5.8.1 Switched Access Traffic. Switched Access Traffic is defined as telephone calls requiring local transmission or switching services for the purpose of the origination or termination of Telephone Toll Service. Switched Access Traffic includes the following types of traffic: Feature Group A, Feature Group B, Feature Group C, Feature Group D, toll free access (e.g., 800/877/888), 900 access, and their successors or similar Switched Exchange Access Services. The Parties have been unable to agree as to whether "Voice-Over-Internet Protocol" transmissions ("VOIP") which cross LATA boundaries constitute Switched Access Traffic. Notwithstanding the foregoing, and without waiving any rights with respect to either Party's position as to the jurisdictional nature of VOIP, the Parties agree to abide by any effective and applicable FCC rules and orders regarding the nature of such traffic and the compensation payable by the Parties for such traffic, if any.
- 5.8.2 When Level 3's end office switch, subtending the BellSouth Access Tandem switch for receipt or delivery of switched access traffic, provides an access service connection to or from an interexchange carrier ("IXC") by either a direct trunk group to the IXC utilizing BellSouth facilities, or via BellSouth's tandem switch, each Party will provide its own access services to the IXC and bill on a multi-bill, multi-tariff meet-point basis. Each Party will bill its own access services rates to the IXC with the exception of the interconnection charge. The interconnection charge, if applicable, will be billed by the Party providing the end office function. Each party will use the Multiple Exchange Carrier Access Billing (MECAB) guidelines to establish meet point billing for all applicable traffic. Thirty (30)-day billing periods will be employed for these arrangements. For tandem routed traffic, the tandem company agrees to provide to the Initial Billing Company as defined in MECAB, at no charge, all the switched access detail usage data, recorded at the access tandem, within no more than sixty (60) days after the recording date. The Initial Billing Company will provide the switched access summary usage data, for all originating and terminating traffic, to all Subsequent Billing Companies as defined in MECAB within 10 days of rendering the initial bill to the IXC. Each Party will notify the other when it is not feasible to meet these requirements so that the customers may be notified for any necessary revenue accrual associated with the significantly delayed recording or billing.

As business requirements change data reporting requirements may be modified as necessary.

- 5.8.3 In the event that either Party fails to provide switched access detailed usage data to the other Party within 90 days after the recording date and the receiving Party is unable to bill and/or collect access revenues due to the sending Party's failure to provide such data within said time period, then the Party failing to send the data as specified herein shall be liable to the other Party in an amount equal to the unbillable or uncollectible revenues. Each company will provide complete documentation to the other to substantiate any claim of unbillable access revenues and a negotiated settlement will be agreed upon between the Parties.
- 5.8.4 Each Party will retain for a minimum period of sixty (60) days, access message detail sufficient to recreate any data which is lost or damaged by their company or any third party involved in processing or transporting data.
- 5.8.5 Each Party agrees to recreate the lost or damaged data within forty-eight (48) hours of notification by the other or by an authorized third party handling the data.
- 5.8.6 Each Party also agrees to process the recreated data within forty-eight (48) hours of receipt at its data processing center.
- 5.8.7 All claims should be filed with the other Party within 120 days of the receipt of the date of the unbillable usage.
- 5.8.8 The Initial Billing Company shall keep records of its billing activities relating to jointly-provided Intrastate and Interstate access services in sufficient detail to permit the Subsequent Billing Party to, by formal or informal review or audit, to verify the accuracy and reasonableness of the jointly-provided access billing data provided by the Initial billing Party. Each Party agrees to cooperate in such formal or informal reviews or audits and further agrees to jointly review the findings of such reviews or audits in order to resolve any differences concerning the findings thereof.
- 5.8.9 Level 3 agrees not to deliver switched access traffic to BellSouth for termination except over Level 3 ordered switched access trunks and facilities.

5.9 **Transit Traffic Service**

- 5.9.1 BellSouth shall provide tandem switching and transport services for Level 3's Transit Traffic. Transit traffic is traffic originating on Level 3's network that is switched and/or transported by BellSouth and delivered to a third party's network, or traffic originating on a third Party's network that is switched and/or transported by BellSouth and delivered to Level 3's network. Rates for Local Transit Traffic shall be the applicable call transport and termination charges as set forth in Exhibit A to this Attachment. Rates for IntraLATA Toll and Switched Access Transit Traffic shall be the applicable call transport and

termination charges as set forth in BellSouth's or Level 3's Commission or FCC-filed and effective Interstate or Intrastate Switched Access tariffs. Switched Access Transit Traffic presumes that Level 3's end office is subtending the BellSouth Access Tandem for switched access traffic to and from Level 3's end users utilizing BellSouth facilities, either by direct trunks with the IXC, or via the BellSouth Access Tandem. Billing associated with all Transit Traffic shall be pursuant to Multiple Exchange Carrier Access Billing (MECAB) guidelines. Pursuant to these guidelines, the Initial Billing Company shall provide summary usage data, for all originating and terminating Transit Traffic, to all Subsequent Billing Companies. Traffic between Level 3 and Wireless Type 1 third parties shall not be treated as Transit Traffic from a routing or billing perspective. Traffic between Level 3 and Wireless Type 2A or UNE-CLEC third parties shall not be treated as Transit Traffic from a routing or billing perspective until BellSouth and the Wireless carrier or UNE-CLEC third party have the capability to properly meet-point-bill in accordance with MECAB guidelines.

- 5.9.2 The delivery of traffic which transits the BellSouth network and is transported to another carrier's network is excluded from any BellSouth billing guarantees and will be delivered at the rates stipulated in this Agreement to a terminating carrier. BellSouth agrees to deliver this traffic to the terminating carrier; provided, however, that Level 3 is solely responsible for negotiating and executing any appropriate contractual agreements, where required with the third party, with the terminating carrier for the receipt of this traffic through the BellSouth network. BellSouth will not be liable for any compensation to the terminating carrier or to Level 3. Level 3 agrees to compensate BellSouth for any charges or costs for the delivery of Transit Traffic to a connecting carrier on behalf of Level 3. Additionally, the Parties agree that any billing to a third party or other telecommunications carrier under this section shall be pursuant to MECAB procedures.

6. **Frame Relay Service Interconnection**

- 6.1 In addition to the Local Interconnection services set forth above, BellSouth will offer a network to network Interconnection arrangement between BellSouth's and Level 3's frame relay switches as set forth below. The following provisions will apply only to Frame Relay Service and Exchange Access Frame Relay Service in those states in which Level 3 is certified and providing Frame Relay Service as a Local Exchange Carrier and where traffic is being exchanged between Level 3 and BellSouth Frame Relay Switches in the same LATA.
- 6.2 The Parties agree to establish two-way Frame Relay facilities between their respective Frame Relay Switches to the mutually agreed upon Frame Relay Service point(s) of interconnection ("POI(s)") within the LATA. All POIs shall be within the same Frame Relay Network Serving Areas as defined in Section A40 of BellSouth's General Subscriber Service Tariff except as set forth in this Attachment.
- 6.3 Upon the request of either Party, such interconnection will be established where BellSouth and Level 3 have Frame Relay Switches in the same LATA. Where there

- are multiple Frame Relay switches in one central office, an interconnection with any one of the switches will be considered an interconnection with all of the switches at that central office for purposes of routing packet traffic.
- 6.4 The Parties agree to provision local and IntraLATA Frame Relay Service and Exchange Access Frame Relay Service (both intrastate and interstate) over Frame Relay interconnection facilities between the respective Frame Relay switches and the POIs.
- 6.5 The Parties agree to assess each other reciprocal charges for the facilities that each provides to the other according to the Percent Local Circuit Use Factor (PLCU), determined as follows:
- 6.5.1 If the data packets originate and terminate in locations in the same LATA, and consistent with the local definitions of the Agreement, the traffic is considered local. Frame Relay framed packet data is transported within Virtual Circuits (VC). For the purposes of this Agreement, if all the data packets transported within a VC remain within the LATA, then consistent with the local definitions in this Agreement, the traffic on that VC is local ("Local VC").
- 6.5.2 If the originating and terminating locations of the two way packet data traffic are not in the same LATA, the traffic on that VC is interLATA ("InterLATA VC").
- 6.5.3 The PLCU is determined by dividing the total number of Local VCs, by the total number of VCs on each Frame Relay facility. To facilitate implementation, Level 3 may determine its PLCU in aggregate, by dividing the total number of Local VCs in a given LATA by the total number VCs in that LATA. The Parties agree to renegotiate the method for determining PLCU, at BellSouth's request, and within 90 days, if BellSouth notifies Level 3 that it has found that this method does not adequately represent the PLCU.
- 6.5.4 If there are no VCs on a facility when it is billed, the PLCU will be zero.
- 6.5.5 BellSouth will provide the circuit between the Parties' respective Frame Relay Switches. The Parties will be compensated as follows: BellSouth will invoice, and Level 3 will pay, the total non-recurring and recurring charges for the circuit based upon the rates set forth in BellSouth's Interstate Access Tariff, FCC No. 1. Level 3 will then invoice, and BellSouth will pay, an amount calculated by multiplying the BellSouth billed charges for the circuit by one-half of Level 3's PLCU.
- 6.6 The Parties agree to compensate each other for Frame Relay network-to-network interface (NNI) ports based upon the NNI rates set forth in BellSouth's Interstate Access Tariff, FCC No. 1. Compensation for each pair of NNI ports will be calculated as follows: BellSouth will invoice, and Level 3 will pay, the total non-recurring and recurring charges for the NNI port. Level 3 will then invoice, and BellSouth will pay,

an amount calculated by multiplying the BellSouth billed non-recurring and recurring charges for the NNI port by Level 3's PLCU.

- 6.7 Each Party agrees that there will be no charges to the other Party for its own subscriber's Permanent Virtual Circuit (PVC) rate elements for the local PVC segment from its Frame Relay switch to its own subscriber's premises. PVC rate elements include the Data Link Connection Identifier (DLCI) and Committed Information Rate (CIR).
- 6.8 For the PVC segment between the Level 3 and BellSouth Frame Relay switches, compensation for the PVC charges is based upon the rates in BellSouth's Interstate Access Tariff, FCC No. 1.
- 6.9 Compensation for PVC rate elements will be calculated as follows:
- 6.9.1 If Level 3 orders a VC connection between a BellSouth subscriber's PVC segment and a PVC segment from the BellSouth Frame Relay switch to the Level 3 Frame Relay switch, BellSouth will invoice, and Level 3 will pay, the total non-recurring and recurring PVC charges for the PVC segment between the BellSouth and Level 3 Frame Relay switches. If the VC is a Local VC, Level 3 will then invoice and BellSouth will pay, the total nonrecurring and recurring PVC charges billed for that segment. If the VC is not local, no compensation will be paid to Level 3 for the PVC segment.
- 6.9.2 If BellSouth orders a Local VC connection between a Level 3 subscriber's PVC segment and a PVC segment from the Level 3 Frame Relay switch to the BellSouth Frame Relay switch, BellSouth will invoice, and Level 3 will pay, the total non-recurring and recurring PVC and CIR charges for the PVC segment between the BellSouth and Level 3 Frame Relay switches. If the VC is a Local VC, Level 3 will then invoice and BellSouth will pay the total non-recurring and recurring PVC and CIR charges billed for that segment. If the VC is not local, no compensation will be paid to Level 3 for the PVC segment.
- 6.9.3 The Parties agree to compensate each other for requests to change a PVC segment or PVC service order record, according to the Feature Change charge as set forth in the BellSouth access tariff BellSouth Tariff FCC No, 1.
- 6.9.4 If Level 3 requests a change, BellSouth will invoice and Level 3 will pay a Feature Change charge for each affected PVC segment.
- 6.9.4.1 If BellSouth requests a change to a Local VC, Level 3 will invoice and BellSouth will pay a Feature Change charge for each affected PVC segment.

- 6.9.5 The Parties agree to limit the sum of the CIR for the VCs on a DS1 NNI port to not more than three times the port speed, or not more than six times the port speed on a DS3 NNI port.
- 6.9.6 Except as expressly provided herein, this Agreement does not address or alter in any way either Party's provision of Exchange Access Frame Relay Service or interLATA Frame Relay Service. All charges by each Party to the other for carriage of Exchange Access Frame Relay Service or interLATA Frame Relay Service are included in the BellSouth access tariff BellSouth Tariff FCC No, 1.
- 6.10 Level 3 will identify and report quarterly to BellSouth the PLCU of the Frame Relay facilities it uses, per section 8.5.3 above.
- 6.11 Either Party may request a review or audit of the various service components, consistent with the provisions of section E2 of the BellSouth State Access Services tariffs or Section 2 of the BellSouth FCC No.1 Tariff.
- 6.12 If during the term of this Agreement, BellSouth obtains authority to provide interLATA Frame Relay in any State, the Parties agree to renegotiate this arrangement for the exchange of Frame Relay Service Traffic within one hundred eighty (180) days of the date BellSouth receives interLATA authority. In the event the Parties fail to renegotiate this Section 8 within the one hundred eighty day period, they will submit this matter to the appropriate State commission(s) for resolution.
7. **Operational Support Systems (OSS)**
The terms, conditions and rates for OSS are as set forth in Section 2.14 of Attachment 2.

Exhibit B

Basic Architecture

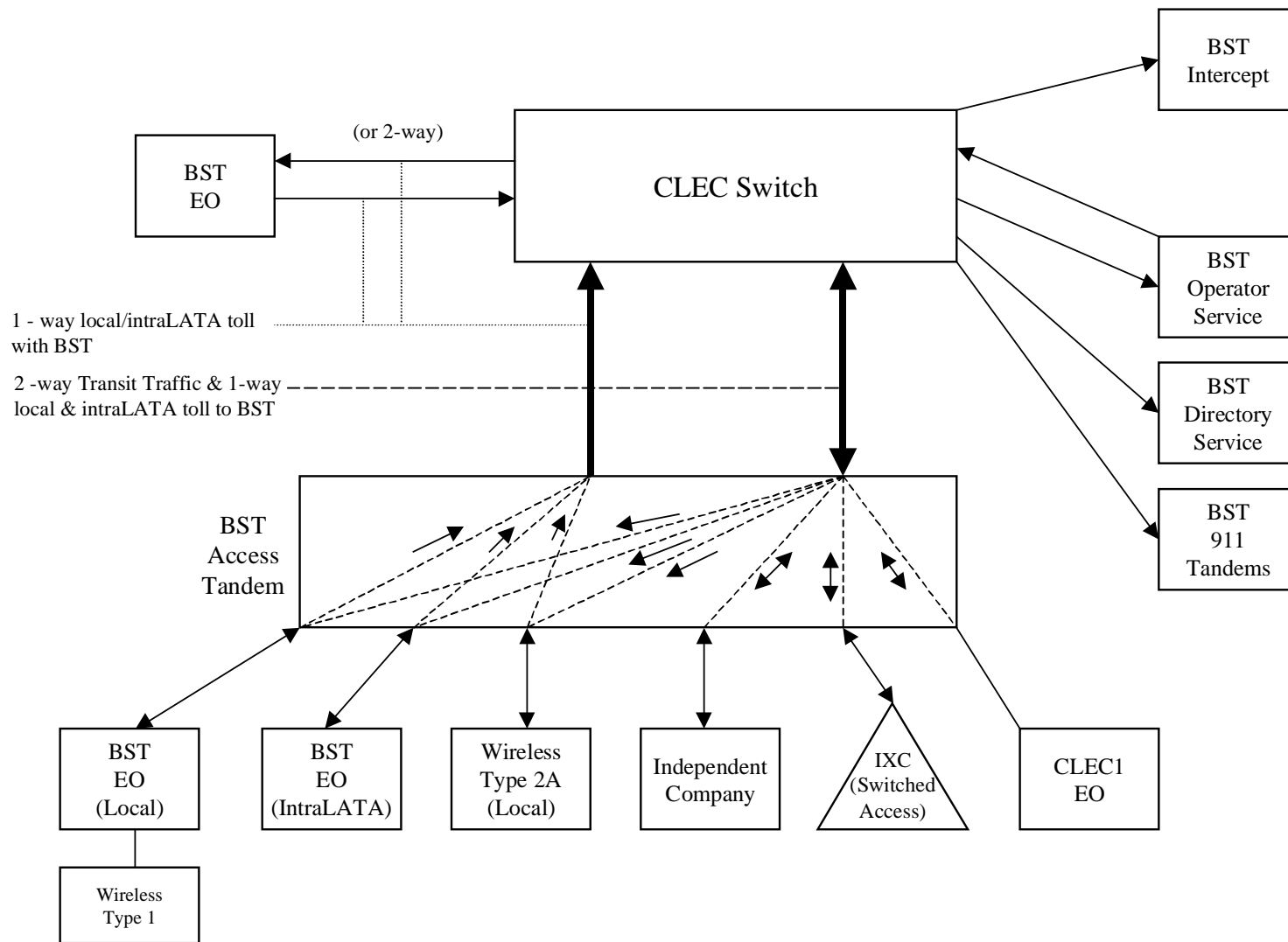

Exhibit C

One-Way Architecture

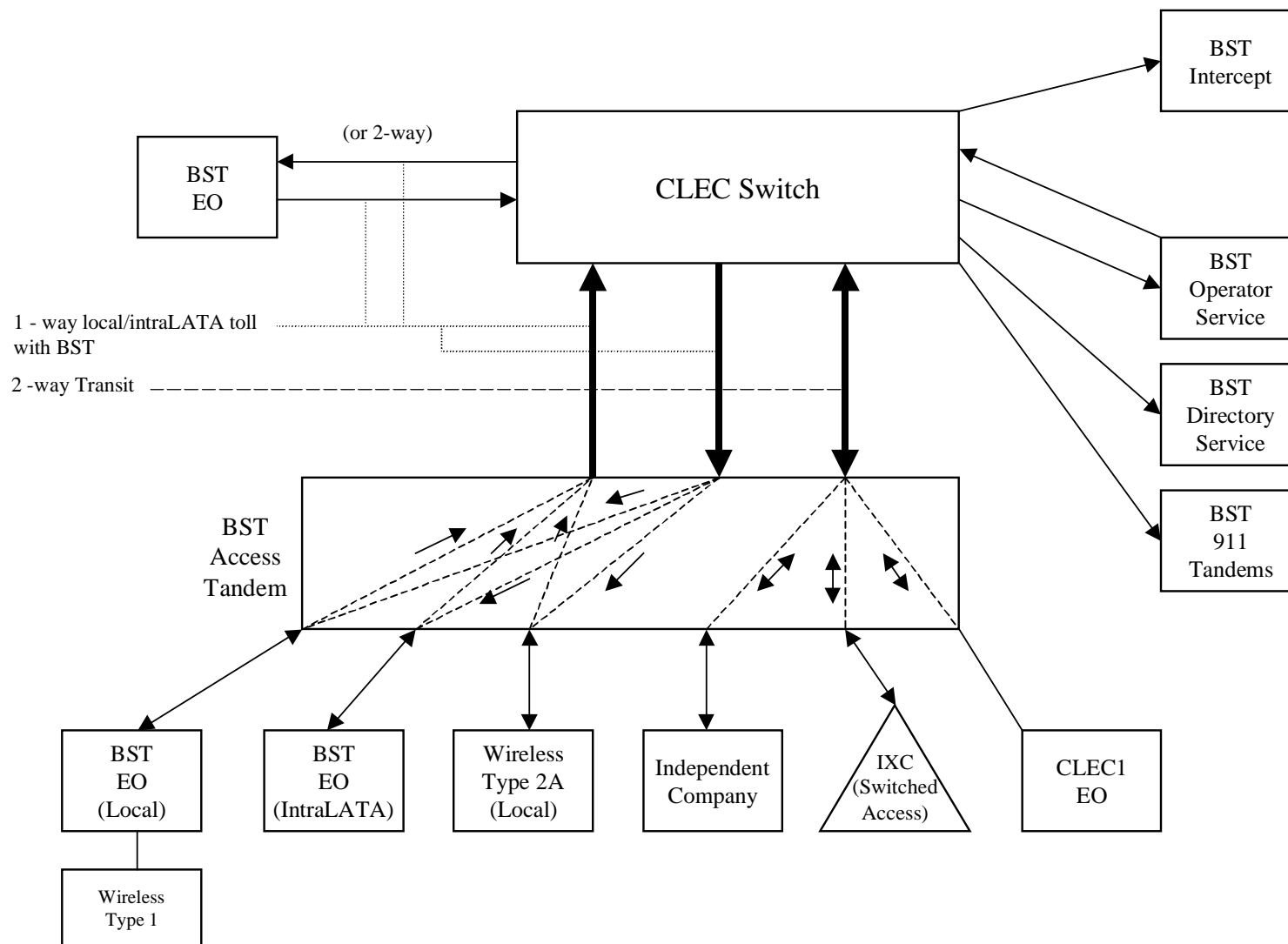

Exhibit D

Two-Way Architecture

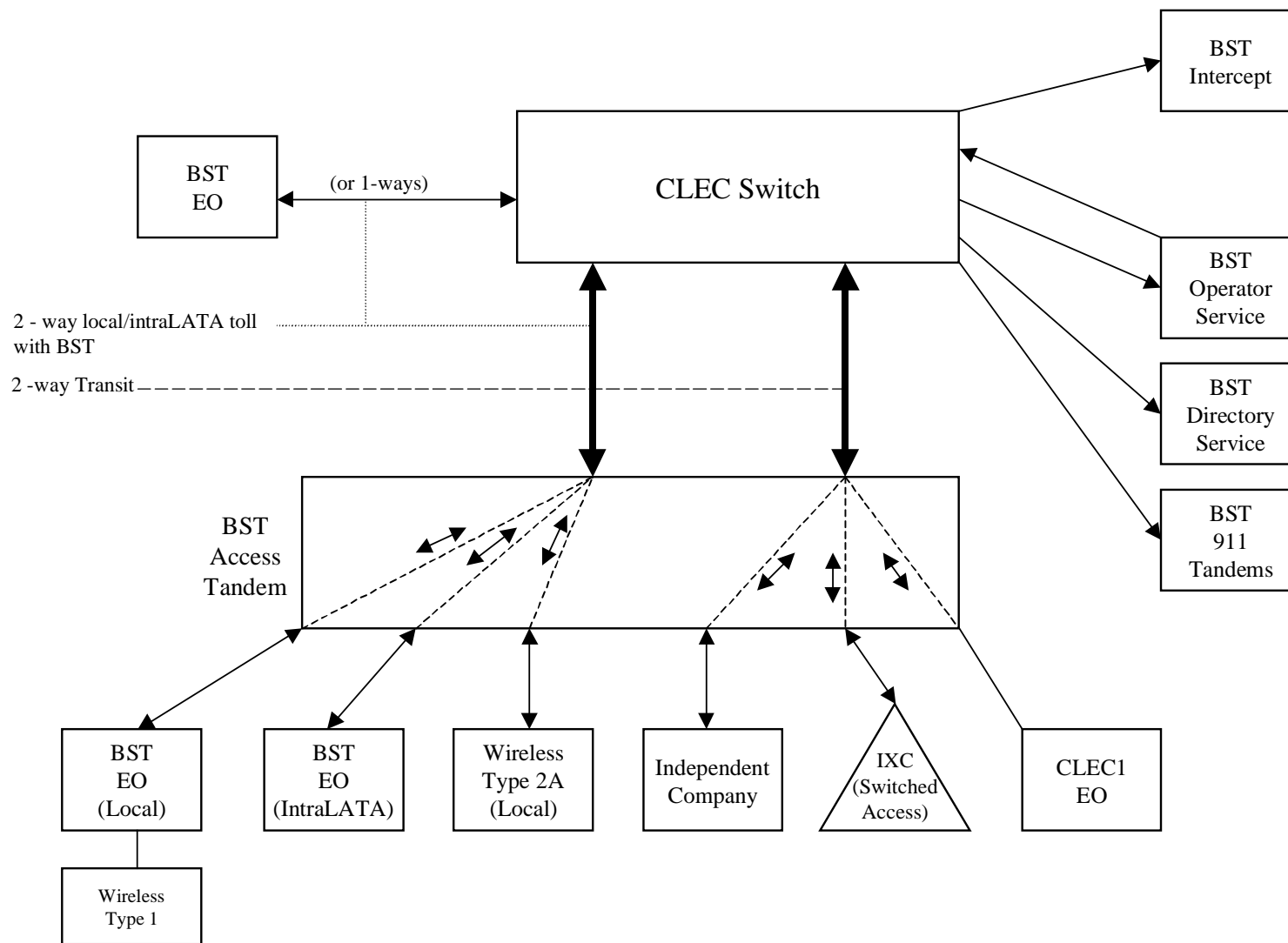
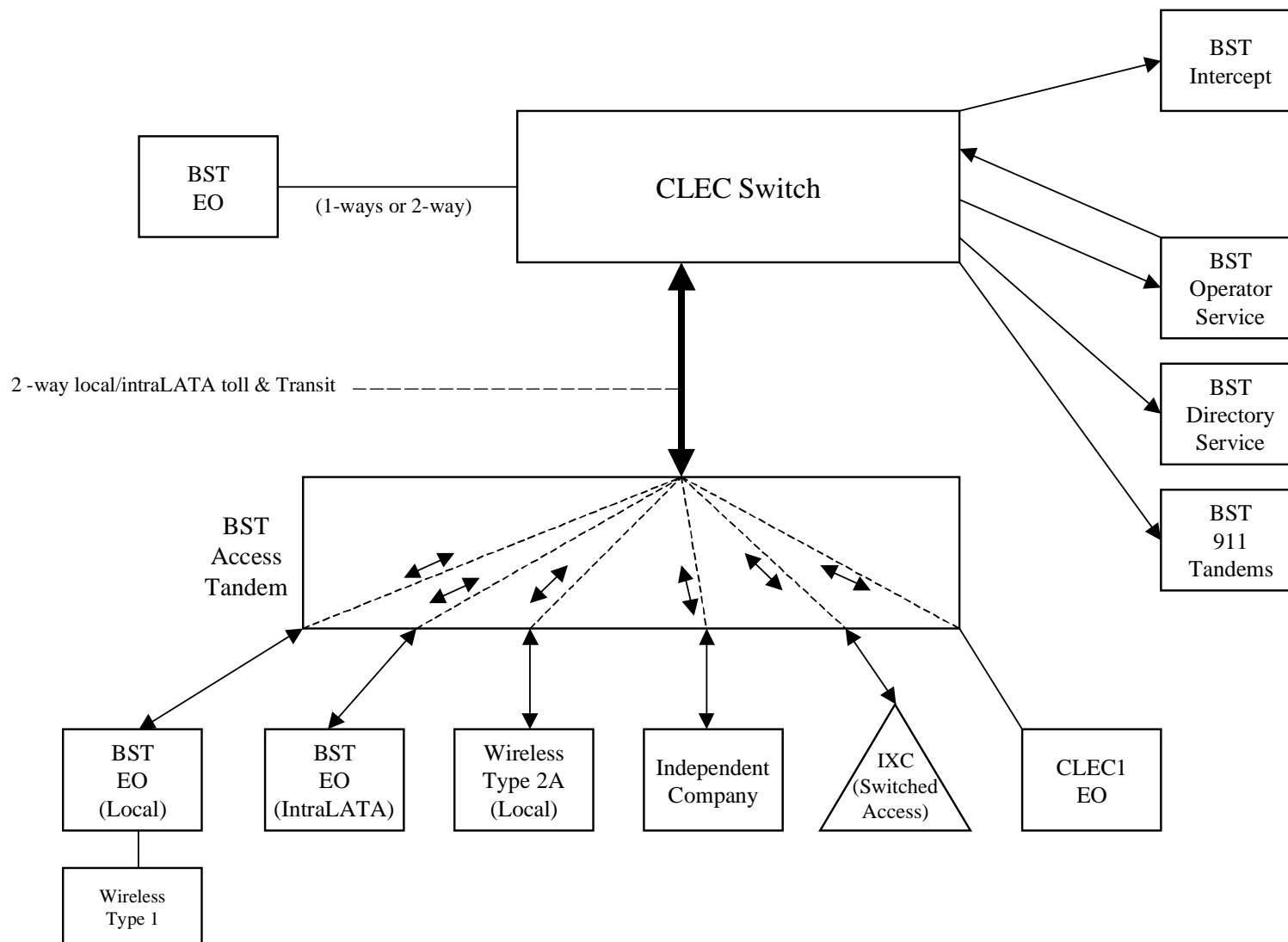

Exhibit E

Supergroup Architecture



BELLSOUTH/LEVEL 3 RATES
LOCAL INTERCONNECTION

		RATES BY STATE									
DESCRIPTION	USOC	AL	FL	GA	KY	LA	MS	NC	SC	TN	
LOCAL INTERCONNECTION (CALL TRANSPORT AND TERMINATION)											
End Office Switching, per mou	N/A	\$0.0018	NA	\$0.0016333	\$0.002562	NA	\$0.0023771	\$0.0017	\$0.0019295	\$0.0019	
Direct Local Interconnection, per mou (same as End Office Switching in FL & LA)		NA	\$0.002	NA	NA	\$0.00209	NA	NA	NA	NA	
Tandem Switching, per mou	N/A	\$0.00063	\$0.00029	\$0.0006757	\$0.001096	NA	\$0.0007834	\$0.0009	\$0.0006843	\$0.000676	
Tandem Switching (assumes 5 miles of transport per mou)	N/A	NA	NA	NA	NA	\$0.00430	NA	NA	NA	NA	
Tandem Local Interconnection, per mou (includes end office switching element)	N/A	NA	\$0.00325	NA	NA	\$0.00639	NA	NA	NA	NA	
Multiple Tandem Switching, per mou (applies to initial tandem only), effective 10/99	N/A	NA	\$0.00125	NA	NA	\$0.00430	NA	NA	NA	NA	
Local Intermediary, per mou (applies to transit traffic only)	N/A	NA	\$0.00125	NA	NA	\$0.00430	NA	NA	NA	NA	
Tandem Intermediary Charge, per mou*	N/A	\$0.0015	NA	NA	\$0.001096	NA	NA	NA	NA	NA	
*(This charge is applicable only to transit traffic and is applied in addition to applicable switching and/or interconnection charges.)											
TRUNK CHARGE											
Interim charges, both non-recurring and recurring, associated with interconnecting trunk groups between BellSouth and CLEC-1 shall be as set forth in this Exhibit. At such time as BellSouth develops a final cost based rate for such interconnecting trunk groups, the Parties shall amend this agreement to include such final cost based rates and shall true up such charges in accordance with this Attachment.											
Installation Trunk Side Service - per DSO											
NRC - 1st	TPP++	\$333.69	\$336.43	\$333.28	\$334.09	\$334.94	\$334.11	\$333.54	\$335.14	\$334.29	
NRC - Add'l	TPP++	\$56.91	\$57.38	\$56.84	\$57.12	\$56.98	\$56.98	\$56.88	\$57.16	\$57.01	
INTEROFFICE TRANSPORT											
Common (Shared) Transport											
Common (Shared) Transport per mile per mou	N/A	\$0.00001	\$0.000012	\$0.000008	\$0.0000049	\$0.0000083	\$0.0000091	\$0.00001	\$0.0000121	\$0.00004	
Common (Shared) Transport Facilities Termination per mou	N/A	\$0.00045	\$0.0005	\$0.0004152	\$0.000426	\$0.00047	\$0.0004281	\$0.00034	\$0.0004672	\$0.00036	
Interoffice Channel Transport - Dedicated - VG											
Interoffice Transport - Dedicated - 2-wire VG											
2-Wire VG - per mile per month	1L5XF	\$0.03	\$0.0100	\$0.02	NA	\$0.04	NA	\$0.03	\$0.04	\$0.02	
2-Wire VG - Facility Termination per month	1L5XF	\$18.49	\$26.72	\$17.07	NA	\$19.10	NA	\$18.01	\$21.42	\$18.33	
NRC - 2-wire VG - Facility Termination -1st	1L5XF	\$107.11	\$81.73	\$79.61	NA	\$76.20	NA	\$137.48	\$136.44	\$55.39	
NRC - 2-wire VG - Facility Termination - Add'l	1L5XF	\$48.27	\$55.26	\$36.08	NA	\$34.54	NA	\$52.58	\$51.37	\$17.37	
NRC - 2-wire VG -Facility Termination - Disconnect Charge -1st	1L5XF	\$37.16	\$31.26	NA	NA	\$28.03	NA	NA	NA	\$27.96	
NRC - 2-wire VG - Facility Termination - Disconnect Charge -Add'l	1L5XF	\$5.88	\$12.88	NA	NA	\$5.37	NA	NA	NA	\$3.51	
NRC - Manual Svc Order, per LSR	SOMAN	NA	\$21.73	NA	NA	NA	NA	NA	NA	\$19.99	
NRC - Manual Svc Order, per LSR disconnect	SOMAN	NA	\$3.87	NA	NA	NA	NA	NA	NA	NA	
NRC - Electronic Svc Order, per LSR	SOMECE	\$3.50	\$2.77	\$3.50	NA	\$3.50	NA	\$3.50	\$3.50	\$3.50	
NRC - Electronic Svc Order, per LSR disconnect	SOMECE	NA	\$0.43	NA	NA	NA	NA	NA	NA	NA	
NRC - 2-wire VG - Incremental Charge--Manual Svc Order - 1st	SOMAN	\$27.37	NA	\$18.94	NA	\$18.14	NA	\$38.07	\$39.63	NA	
NRC - 2-wire VG - Incremental Charge--Manual Svc Order - Add'l	SOMAN	\$27.57	NA	\$18.94	NA	\$18.14	NA	\$38.07	\$39.63	NA	
NRC - 2-wire VG - Incremental Charge--Manual Svc Order-Disconnect--1st	SOMAN	\$12.97	NA	NA	NA	\$8.06	NA	NA	NA	NA	
NRC - 2-wire VG - Incremental Charge--Manual Svc Order-Disconnect--Add'l	SOMAN	\$12.97	NA	NA	NA	\$8.06	NA	NA	NA	NA	
Interoffice Transport - Dedicated - 2 Wire VG - Kentucky & Mississippi											
2-Wire VG - per mile per month	1L5NF	NA	NA	NA	\$0.03	NA	\$0.03	NA	NA	NA	
2-Wire VG - Facility Termination per month	1L5NF	NA	NA	NA	\$27.66	NA	\$21.33	NA	NA	NA	
NRC - 2-wire VG - Facility Termination -1st	1L5NF	NA	NA	NA	\$142.31	NA	\$106.72	NA	NA	NA	
NRC - 2-wire VG - Facility Termination - Add'l	1L5NF	NA	NA	NA	\$56.21	NA	\$48.83	NA	NA	NA	
NRC - 2-wire VG -Facility Termination - Disconnect Charge -1st	1L5NF	NA	NA	NA	NA	NA	\$38.05	NA	NA	NA	
NRC - 2-wire VG - Facility Termination - Disconnect Charge -Add'l	1L5NF	NA	NA	NA	NA	NA	\$7.23	NA	NA	NA	

Version 2000: 7/17/00

BELLSOUTH/LEVEL 3 RATES
LOCAL INTERCONNECTION

			RATES BY STATE									
DESCRIPTION	USOC	AL	FL	GA	KY	LA	MS	NC	SC	TN		
NRC - Manual Svc Order, per LSR	SOMAN	NA	NA	NA	\$19.99	NA	NA	NA	NA	NA		
NRC - Manual Svc Order, per LSR disconnect	SOMAN	NA	NA	NA	NA	NA	NA	NA	NA	NA		
NRC - Electronic Svc Order, per LSR	SOMECE	NA	NA	NA	\$3.50	NA	\$3.50	NA	NA	NA		
NRC - Electronic Svc Order, per LSR disconnect	SOMECE	NA	NA	NA	NA	NA	NA	NA	NA	NA		
NRC - 2-wire VG - Incremental Charge--Manual Svc Order - 1st	SOMAN	NA	NA	NA	NA	NA	\$25.52	NA	NA	NA		
NRC - 2-wire VG - Incremental Charge--Manual Svc Order - Add'l	SOMAN	NA	NA	NA	NA	NA	\$25.52	NA	NA	NA		
NRC - 2-wire VG - Incremental Charge--Manual Svc Order-Disconnect--1st	SOMAN	NA	NA	NA	NA	NA	\$11.34	NA	NA	NA		
NRC - 2-wire VG - Incremental Charge--Manual Svc Order-Disconnect--Add'l	SOMAN	NA	NA	NA	NA	NA	\$11.34	NA	NA	NA		
Interoffice Transport - Dedicated - DS0 - 56/64 KBPS												
DS0 - per mile per month	1L5XK	\$0.69	\$0.2035	\$0.31	NA	\$0.78	NA	\$0.58	\$0.76	\$0.35		
DS0 - Facility Termination per month	1L5XK	\$79.69	\$93.31	\$63.39	NA	\$93.40	NA	\$71.29	\$94.98	\$75.83		
NRC - DS0 - Facility Termination - 1st	1L5XK	\$198.15	\$179.99	\$147.07	NA	\$140.49	NA	\$217.17	\$216.27	\$145.98		
NRC - DS0 - Facility Termination - Add'l	1L5XK	\$148.18	\$164.95	\$111.75	NA	\$106.69	NA	\$163.75	\$162.70	\$109.85		
NRC - DS0 -Facility Termination - Disconnect Charge - 1st	1L5XK	\$25.44	\$30.54	NA	NA	\$20.00	NA	NA	NA	\$19.55		
NRC - DS0 - Facility Termination - Disconnect Charge - Add'l	1L5XK	\$20.42	\$26.97	NA	NA	\$16.34	NA	NA	NA	\$14.99		
NRC - Manual Svc Order, per LSR	SOMAN	NA	\$21.73	NA	NA	NA	NA	NA	NA	\$19.99		
NRC - Manual Svc Order, per LSR disconnect	SOMAN	NA	\$3.87	NA	NA	NA	NA	NA	NA	NA		
NRC - Electronic Svc Order, per LSR	SOMECE	\$3.50	\$2.77	\$3.50	NA	\$3.50	NA	\$3.50	\$3.50	\$3.50		
NRC - Electronic Svc Order, per LSR disconnect	SOMECE	NA	\$0.43	NA	NA	NA	NA	NA	NA	NA		
NRC - DS0 -Incremental Charge--Manual Svc Order - 1st	SOMAN	\$27.37	NA	\$18.94	NA	\$18.14	NA	\$38.07	\$39.63	NA		
NRC -DS0 - Incremental Charge--Manual Svc Order - Add'l	SOMAN	\$27.37	NA	\$18.94	NA	\$18.14	NA	\$38.07	\$39.63	NA		
NRC - DS0 -Incremental Charge--Manual Svc Order-Disconnect--1st	SOMAN	\$12.97	NA	NA	NA	\$8.06	NA	NA	NA	NA		
NRC - DS0 -Incremental Charge--Manual Svc Order-Disconnect--Add'l	SOMAN	\$12.97	NA	NA	NA	\$8.06	NA	NA	NA	NA		
Interoffice Transport - Dedicated - DS0 - 56/64 KBPS - Kentucky & Mississippi												
DS0 - per mile per month	1L5NK	NA	NA	NA	\$0.45	NA	\$0.66	NA	NA	NA		
DS0 - Facility Termination per month	1L5NK	NA	NA	NA	\$55.05	NA	\$74.40	NA	NA	NA		
NRC - DS0 - Facility Termination - 1st	1L5NK	NA	NA	NA	\$298.18	NA	\$196.28	NA	NA	NA		
NRC - DS0 - Facility Termination - Add'l	1L5NK	NA	NA	NA	\$231.23	NA	\$147.31	NA	NA	NA		
NRC - DS0 -Facility Termination - Disconnect Charge - 1st	1L5NK	NA	NA	NA	NA	NA	\$26.56	NA	NA	NA		
NRC - DS0 - Facility Termination - Disconnect Charge - Add'l	1L5NK	NA	NA	NA	NA	NA	\$21.61	NA	NA	NA		
NRC - Manual Svc Order, per LSR	SOMAN	NA	NA	NA	\$19.99	NA	NA	NA	NA	NA		
NRC - Manual Svc Order, per LSR disconnect	SOMAN	NA	NA	NA	NA	NA	NA	NA	NA	NA		
NRC - Electronic Svc Order, per LSR	SOMECE	NA	NA	NA	\$3.50	NA	\$3.50	NA	NA	NA		
NRC - Electronic Svc Order, per LSR disconnect	SOMECE	NA	NA	NA	NA	NA	NA	NA	NA	NA		
NRC - DS0 -Incremental Charge--Manual Svc Order - 1st	SOMAN	NA	NA	NA	NA	NA	\$25.52	NA	NA	NA		
NRC -DS0 - Incremental Charge--Manual Svc Order - Add'l	SOMAN	NA	NA	NA	NA	NA	\$25.52	NA	NA	NA		
NRC - DS0 -Incremental Charge--Manual Svc Order-Disconnect--1st	SOMAN	NA	NA	NA	NA	NA	\$11.31	NA	NA	NA		
NRC - DS0 -Incremental Charge--Manual Svc Order-Disconnect--Add'l	SOMAN	NA	NA	NA	NA	NA	\$11.34	NA	NA	NA		
Interoffice Transport - Dedicated - DS1												
DS3 - per mile per month	1L5XL	\$0.69	\$0.2035	\$0.31	NA	\$0.78	NA	\$0.58	\$0.76	\$0.35		
DS3 -Facility Termination per month	1L5XL	\$79.69	\$93.31	\$63.39	NA	\$93.40	NA	\$71.29	\$94.98	\$75.83		
NRC - DS1-Facility Termination - 1st	1L5XL	\$198.15	\$179.99	\$147.07	NA	\$140.49	NA	\$217.17	\$216.27	\$145.98		
NRC - DS1 - Facility Termination - Add'l	1L5XL	\$148.18	\$164.95	\$111.75	NA	\$106.69	NA	\$163.75	\$162.70	\$109.85		
NRC - DS1 - Facility Termination - Disconnect Charge - 1st	1L5XL	\$25.44	\$30.54	NA	NA	\$20.00	NA	NA	NA	\$19.55		
NRC - DS1 - Facility Termination -Disconnect Charge - Add'l	1L5XL	\$20.42	\$26.97	NA	NA	\$16.34	NA	NA	NA	\$14.99		

BELLSOUTH/LEVEL 3 RATES
LOCAL INTERCONNECTION

			RATES BY STATE								
DESCRIPTION	USOC	AL	FL	GA	KY	LA	MS	NC	SC	TN	
NRC - Manual Svc Order, per LSR	SOMAN	NA	\$21.73	NA	NA	NA	NA	NA	NA	\$19.99	
NRC - Manual Svc Order, per LSR disconnect	SOMAN	NA	\$3.87	NA	NA	NA	NA	NA	NA	NA	
NRC - Electronic Svc Order, per LSR	SOMECE	\$3.50	\$2.77	\$3.50	NA	\$3.50	NA	\$3.50	\$3.50	\$3.50	
NRC - Electronic Svc Order, per LSR disconnect	SOMECE	NA	\$0.43	NA	NA	NA	NA	NA	NA	NA	
NRC - DS1 - Incremental Charge--Manual Svc Order - 1st	SOMAN	\$27.37	NA	\$18.94	NA	\$18.14	NA	\$38.07	\$39.63	NA	
NRC -DS1 - Incremental Charge--Manual Svc Order - Add'l	SOMAN	\$27.37	NA	\$18.94	NA	\$18.14	NA	\$38.07	\$39.63	NA	
NRC - DS1 - Incremental Charge--Manual Svc Order-Disconnect--1st	SOMAN	\$12.97	NA	NA	NA	\$8.06	NA	NA	NA	NA	
NRC - DS1 - Incremental Charge--Manual Svc Order-Disconnect--Add'l	SOMAN	\$12.97	NA	NA	NA	\$8.06	NA	NA	NA	NA	
Interoffice Transport - Dedicated - DS1 - Kentucky & Mississippi											
DS3 - per mile per month	1L5NL	NA	NA	NA	\$0.45	NA	\$0.66	NA	NA	NA	
DS3 -Facility Termination per month	1L5NL	NA	NA	NA	\$55.05	NA	\$74.40	NA	NA	NA	
NRC - DS1-Facility Termination - 1st	1L5NL	NA	NA	NA	\$298.18	NA	\$196.28	NA	NA	NA	
NRC - DS1 - Facility Termination - Add'l	1L5NL	NA	NA	NA	\$231.23	NA	\$147.31	NA	NA	NA	
NRC - DS1 - Facility Termination - Disconnect Charge - 1st	1L5NL	NA	NA	NA	NA	NA	\$26.56	NA	NA	NA	
NRC - DS1 - Facility Termination -Disconnect Charge - Add'l	1L5NL	NA	NA	NA	NA	NA	\$21.61	NA	NA	NA	
NRC - Manual Svc Order, per LSR	SOMAN	NA	NA	NA	\$19.99	NA	NA	NA	NA	NA	
NRC - Manual Svc Order, per LSR disconnect	SOMAN	NA	NA	NA	NA	NA	NA	NA	NA	NA	
NRC - Electronic Svc Order, per LSR	SOMECE	NA	NA	NA	\$3.50	NA	\$3.50	NA	NA	NA	
NRC - Electronic Svc Order, per LSR disconnect	SOMECE	NA	NA	NA	NA	NA	NA	NA	NA	NA	
NRC - DS1 - Incremental Charge--Manual Svc Order - 1st	SOMAN	NA	NA	NA	NA	NA	\$25.52	NA	NA	NA	
NRC -DS1 - Incremental Charge--Manual Svc Order - Add'l	SOMAN	NA	NA	NA	NA	NA	\$25.52	NA	NA	NA	
NRC - DS1 - Incremental Charge--Manual Svc Order-Disconnect--1st	SOMAN	NA	NA	NA	NA	NA	\$11.31	NA	NA	NA	
NRC - DS1 - Incremental Charge--Manual Svc Order-Disconnect--Add'l	SOMAN	NA	NA	NA	NA	NA	\$11.34	NA	NA	NA	
Interoffice Transport - Dedicated - DS3											
DS3 - per mile per month	1L5XM	\$4.98	\$4.25	\$2.72	NA	\$6.78	NA	\$12.98	\$8.13	\$6.88	
DS3 -Facility Termination per month	1L5XM	\$898.15	\$1,130	\$788.00	NA	\$1,025.00	NA	\$720.38	\$967.70	\$840.61	
NRC - DS3 - Facility Termination -1st	1L5XM	\$511.77	\$562.06	\$511.10	NA	\$475.31	NA	\$794.94	\$606.72	\$723.44	
NRC - DS3 - Facility Termination - Add'l	1L5XM	\$330.92	\$328.16	\$330.77	NA	\$307.62	NA	\$579.55	\$423.45	\$409.58	
NRC - DS3 - Facility Termination - Disconnect Charge - 1st	1L5XM	\$121.72	\$112.44	\$122.31	NA	\$113.75	NA	NA	NA	\$154.26	
NRC - DS3 - Facility Termination - Disconnect Charge - Add'l	1L5XM	\$118.54	\$109.19	\$119.14	NA	\$110.80	NA	NA	NA	\$130.74	
NRC - Manual Svc Order, per LSR	SOMAN	NA	\$21.73	NA	NA	NA	NA	NA	NA	\$19.99	
NRC - Manual Svc Order, per LSR disconnect	SOMAN	NA	\$3.87	NA	NA	NA	NA	NA	NA	NA	
NRC - Electronic Svc Order, per LSR	SOMECE	\$3.50	\$2.77	\$3.50	NA	\$3.50	NA	\$3.50	\$3.50	\$3.50	
NRC - Electronic Svc Order, per LSR disconnect	SOMECE	NA	\$0.43	NA	NA	NA	NA	NA	NA	NA	
NRC - DS3 - Incremental Charge--Manual Svc Order - 1st	SOMAN	\$38.48	NA	\$37.55	NA	\$34.92	NA	\$91.26	\$54.26	NA	
NRC - DS3 - Incremental Charge--Manual Svc Order - Add'l	SOMAN	\$38.48	NA	\$37.55	NA	\$34.92	NA	\$91.26	\$54.26	NA	
NRC - DS3 - Incremental Charge--Manual Svc Order-Disconnect--1st	SOMAN	\$19.03	NA	\$18.03	NA	\$16.77	NA	NA	NA	NA	
NRC - DS3 - Incremental Charge--Manual Svc Order-Disconnect--Add'l	SOMAN	\$19.03	NA	\$18.03	NA	\$16.77	NA	NA	NA	NA	
Interoffice Transport - Dedicated - DS3 - Kentucky & Mississippi											
DS3 - per mile per month	1L5NM	NA	NA	NA	\$12.06	NA	\$15.02	NA	NA	NA	
DS3 -Facility Termination per month	1L5NM	NA	NA	NA	\$1,112.02	NA	\$744.38	NA	NA	NA	
NRC - DS3 - Facility Termination -1st	1L5NM	NA	NA	NA	\$858.75	NA	\$686.74	NA	NA	NA	
NRC - DS3 - Facility Termination - Add'l	1L5NM	NA	NA	NA	\$524.95	NA	\$477.76	NA	NA	NA	
NRC - DS3 - Facility Termination - Disconnect Charge - 1st	1L5NM	NA	NA	NA	NA	NA	\$125.56	NA	NA	NA	
NRC - DS3 - Facility Termination - Disconnect Charge - Add'l	1L5NM	NA	NA	NA	NA	NA	\$118.79	NA	NA	NA	
NRC - Manual Svc Order, per LSR	SOMAN	NA	NA	NA	\$19.99	NA	NA	NA	NA	NA	

BELLSOUTH/LEVEL 3 RATES
LOCAL INTERCONNECTION

			RATES BY STATE									
DESCRIPTION	USOC	AL	FL	GA	KY	LA	MS	NC	SC	TN		
NRC - Manual Svc Order, per LSR disconnect	SOMAN	NA	NA	NA	NA	NA	NA	NA	NA	NA		
NRC - Electronic Svc Order, per LSR	SOMECE	NA	NA	NA	\$3.50	NA	\$3.50	NA	NA	NA		
NRC - Electronic Svc Order, per LSR disconnect	SOMECE	NA	NA	NA	NA	NA	NA	NA	NA	NA		
NRC - DS3 - Incremental Charge--Manual Svc Order - 1st	SOMAN	NA	NA	NA	NA	NA	\$64.97	NA	NA	NA		
NRC - DS3 - Incremental Charge--Manual Svc Order - Add'l	SOMAN	NA	NA	NA	NA	NA	\$64.97	NA	NA	NA		
NRC - DS3 - Incremental Charge--Manual Svc Order-Disconnect--1st	SOMAN	NA	NA	NA	NA	NA	\$27.08	NA	NA	NA		
NRC - DS3 - Incremental Charge--Manual Svc Order-Disconnect--Add'l	SOMAN	NA	NA	NA	NA	NA	\$27.08	NA	NA	NA		
Local Channel - Dedicated												
Local Channel - Dedicated - 2-Wire VG												
Monthly Recurring per month	TEFV2	\$14.61	\$26.31	\$13.91	\$22.26	\$14.94	\$17.83	\$14.83	\$16.83	\$19.02		
Zone 1	TBD	NA	NA	\$11.91	NA	NA	NA	NA	NA	\$16.42		
Zone 2	TBD	NA	NA	\$13.83	NA	NA	NA	NA	NA	\$20.66		
Zone 3	TBD	NA	NA	\$21.98	NA	NA	NA	NA	NA	\$29.61		
Zone 4	TBD	NA	NA	NA	NA	NA	NA	NA	NA	NA		
NRC - STS-1 - Facility Termination - 1st	TEFV2	\$494.65	\$389.37	\$382.95	\$585.15	\$347.49	\$487.62	\$553.80	\$554.00	\$199.33		
NRC - STS-1 - Facility Termination - Add'l	TEFV2	\$88.44	\$66.88	\$62.40	\$98.53	\$59.75	\$84.35	\$89.69	\$88.58	\$24.16		
NRC - STS-1 - Facility Termination - Disconnect - 1st	TEFV2	\$77.81	\$68.45	NA	\$11.99	\$53.68	\$77.69	NA	NA	\$54.81		
NRC - STS-1 - Facility Termination - Disconnect - Add'l	TEFV2	\$7.63	\$5.97	NA	NA	\$6.60	\$8.95	NA	NA	\$4.80		
NRC - Manual Svc Order, per LSR	SOMAN	NA	\$21.73	NA	\$19.99	NA	NA	NA	NA	\$19.99		
NRC - Manual Svc Order, per LSR disconnect	SOMAN	NA	\$3.87	NA	NA	NA	NA	NA	NA	NA		
NRC - Electronic Svc Order, per LSR	SOMECE	\$3.50	\$2.77	\$3.50	\$3.50	\$3.50	\$3.50	\$3.50	\$3.50	\$3.50		
NRC - Electronic Svc Order, per LSR disconnect	SOMECE	NA	\$0.43	NA	NA	NA	NA	NA	NA	NA		
NRC - STS-1 - Incremental Charge--Manual Svc Order - 1st	SOMAN	\$27.37	NA	\$18.94	NA	\$18.14	\$25.52	\$42.17	\$43.75	NA		
NRC - STS-1 - Incremental Charge--Manual Svc Order - Add'l	SOMAN	\$18.37	NA	\$8.42	NA	\$8.06	\$11.34	\$12.76	\$13.55	NA		
NRC - STS-1 - Incremental Cost - Manual Svc. Order vs. Elect-Disconnect-1st	SOMAN	\$17.75	NA	NA	NA	\$11.40	\$16.05	NA	NA	NA		
Local Channel - Dedicated - 4-Wire VG												
Monthly Recurring per month	TEFV4	\$15.77	\$27.48	\$14.99	\$23.38	\$16.21	\$19.03	\$15.87	\$18.05	\$20.14		
Zone 1	TBD	NA	NA	\$12.90	NA	NA	NA	NA	NA	\$17.38		
Zone 2	TBD	NA	NA	\$14.90	NA	NA	NA	NA	NA	\$21.88		
Zone 3	TBD	NA	NA	\$23.68	NA	NA	NA	NA	NA	\$31.36		
Zone 4	TBD	NA	NA	NA	NA	NA	NA	NA	NA	NA		
NRC - 4-Wire VG - 1st	TEFV4	\$502.43	\$390.25	\$368.44	\$585.15	\$352.75	\$495.25	\$562.23	\$562.46	\$201.53		
NRC - 4-Wire VG - Add'l	TEFV4	\$86.68	\$67.75	\$64.05	\$98.53	\$61.33	\$86.56	\$92.67	\$91.57	\$24.83		
NRC - 4-Wire VG - Disconnect Chg - 1st	TEFV4	\$78.71	\$69.32	NA	NA	\$54.36	\$78.58	NA	NA	\$55.52		
NRC - 4-Wire VG - Disconnect Chg - Add'l	TEFV4	\$8.53	\$6.85	NA	NA	\$7.28	\$9.84	NA	NA	\$5.51		
NRC - Manual Svc Order, per LSR	SOMAN	NA	\$21.73	NA	\$19.99	NA	NA	NA	NA	\$19.99		
NRC - Manual Svc Order, per LSR disconnect	SOMAN	NA	\$3.87	NA	NA	NA	NA	NA	NA	NA		
NRC - Electronic Svc Order, per LSR	SOMECE	NA	\$2.77	\$3.50	\$3.50	\$3.50	\$3.50	\$3.50	\$3.50	\$3.50		
NRC - Electronic Svc Order, per LSR disconnect	SOMECE	\$3.50	\$0.43	NA	NA	NA	NA	NA	NA	NA		
NRC - 4-Wire VG - Incremental Charge--Manual Svc Order - 1st	SOMAN	\$27.37	NA	\$18.94	NA	\$18.14	\$25.52	\$42.17	\$43.64	NA		
NRC - 4-Wire VG - Incremental Charge--Manual Svc Order - Add'l	SOMAN	\$18.73	NA	\$8.42	NA	\$8.06	\$11.34	\$12.76	\$13.55	NA		
Local Channel - Dedicated - DS1												
DS1 Monthly Recurring per month	TEFHG	\$35.52	\$42.98	\$38.36	\$43.80	\$43.80	\$38.91	\$35.68	\$37.20	\$40.27		
DS1 per mile per month	1L5NC	\$0.00	\$0.00	\$0.00	\$0.00	\$0.00	\$0.00	\$0.00	\$0.00	\$0.00		
Zone 1	TBD	NA	NA	\$33.02	NA	NA	NA	NA	NA	\$34.76		
Zone 2	TBD	NA	NA	\$38.13	NA	NA	NA	NA	NA	\$43.75		

BELLSOUTH/LEVEL 3 RATES
LOCAL INTERCONNECTION

		RATES BY STATE									
DESCRIPTION	USOC	AL	FL	GA	KY	LA	MS	NC	SC	TN	
Zone 3	TBD	NA	NA	\$60.60	NA	NA	NA	NA	NA	\$62.70	
Zone 4	TBD	NA	NA	NA	NA	NA	NA	NA	NA	NA	
NRC - DS1 - 1st	TEFHG	\$503.57	\$357.86	\$356.15	\$538.95	\$348.56	\$494.83	\$534.48	\$534.81	\$277.35	
NRC - DS1 - Add'l	TEFHG	\$442.84	\$309.95	\$312.89	\$464.94	\$300.30	\$435.28	\$462.69	\$462.81	\$233.26	
NRC - DS1 - Disconnect Chg - 1st	TEFHG	\$46.28	\$41.46	NA	NA	\$24.15	\$46.85	NA	NA	\$33.18	
NRC - DS1 - Disconnect Chg - Add'l	TEFHG	\$32.18	\$28.51	NA	NA	\$21.31	\$33.02	NA	NA	\$22.30	
NRC - Manual Svc Order, per LSR	SOMAN	NA	\$21.73	NA	\$19.99	NA	NA	NA	NA	\$19.99	
NRC - Manual Svc Order, per LSR disconnect	SOMAN	NA	\$3.87	NA	NA	NA	NA	NA	NA	NA	
NRC - Electronic Svc Order, per LSR	SOMECS	\$3.50	\$2.77	\$3.50	\$3.50	\$3.50	\$3.50	\$3.50	\$3.50	\$3.50	
NRC - Electronic Svc Order, per LSR disconnect	SOMECS	NA	\$0.43	NA	NA	NA	NA	NA	NA	NA	
NRC - DS1 - Incremental Charge--Manual Svc Order - 1st	SOMAN	\$61.95	NA	\$44.22	NA	\$42.34	\$59.58	\$86.15	\$87.99	NA	
NRC - DS1 - Incremental Charge--Manual Svc Order - Add'l	SOMAN	\$0.00	NA	NA	NA	NA	NA	\$1.77	\$3.11	NA	
Local Channel - Dedicated - DS3											
DS3 - per mile per month	1L5NC	\$8.44	\$9.32	\$6.92	\$34.00	\$8.77	NA	NA	\$12.08	\$23.76	
DS3 - Facility Termination per month	TEFHJ	\$535.92	\$560.39	\$515.91	\$635.09	\$573.23	\$533.33	\$498.87	\$493.31	\$607.28	
NRC - DS3 - Facility Termination - 1st	TEFHJ	\$640.54	\$910.45	\$639.50	\$1,091.00	\$594.71	\$526.67	\$562.25	\$735.42	\$726.16	
NRC - DS3 - Facility Termination - Add'l	TEFHJ	\$426.28	\$532.19	\$426.40	\$661.23	\$396.54	\$493.71	\$527.88	\$519.31	\$411.64	
NRC - DS3 - Facility Termination - Disconnect - 1st	TEFHJ	\$121.72	\$112.44	\$122.31	NA	\$113.75	\$42.41	NA	NA	\$103.36	
NRC - DS3 - Facility Termination - Disconnect - Add'l	TEFHJ	\$118.54	\$156.12	\$119.14	NA	\$110.80	\$40.87	NA	NA	\$100.59	
NRC - Manual Svc Order, per LSR	SOMAN	NA	\$21.73	NA	\$19.99	NA	NA	NA	NA	\$19.99	
NRC - Manual Svc Order, per LSR disconnect	SOMAN	NA	\$3.87	NA	NA	NA	NA	NA	NA	NA	
NRC - Electronic Svc Order, per LSR	SOMECS	\$3.50	\$2.77	\$3.50	\$3.50	\$3.50	\$3.50	\$3.50	\$3.50	\$3.50	
NRC - Electronic Svc Order, per LSR disconnect	SOMECS	NA	\$0.43	NA	NA	NA	NA	NA	NA	NA	
NRC - DS3 -Incremental Charge--Manual Svc Order - 1st	SOMAN	\$38.48	NA	\$37.55	NA	\$34.92	\$31.49	\$56.25	\$54.26	NA	
NRC - DS3 - Incremental Charge--Manual Svc Order - Add'l	SOMAN	\$38.48	NA	\$37.55	NA	\$34.92	\$31.49	\$56.25	\$54.26	NA	
NRC - DS3 - Incremental Charge--Manual Svc Order-Disconnect -1st	SOMAN	\$19.03	NA	\$18.03	NA	\$16.77	\$25.35	NA	NA	NA	
NRC - DS3 - Incremental Charge--Manual Svc Order-Disconnect-Add'l	SOMAN	\$19.03	NA	\$18.03	NA	\$16.77	\$25.35	NA	NA	NA	
CHANNELIZATION											
DS3 Channelization (DS3 to DS1)											
per Channelized System (28 DS1) per month	SATCS	\$188.51	\$299.24	\$190.84	NA	\$175.57	NA	\$241.81	\$234.30	\$185.94	
NRC - 1st	SATCS	\$11.67	\$189.04	\$73.29	NA	\$67.42	NA	NA	NA	\$61.09	
NRC - Add'l	SATCS	\$0.95	\$186.37	\$60.61	NA	\$49.13	NA	NA	NA	\$50.31	
NRC - 1st - Disconnect	SATCS	\$17.22	\$14.51	\$0.67	NA	\$15.49	NA	\$16.29	\$11.99	\$3.91	
NRC - Add'l - Disconnect	SATCS	\$12.05	\$13.26	\$12.15	NA	\$11.18	NA	\$12.39	\$12.05	\$12.61	
per Interface per month (COI)	SATCO	\$8.69	\$9.50	\$8.76	NA	\$8.06	NA	\$8.93	\$8.68	\$9.03	
NRC - 1st	SATCO	NA	\$21.73	NA	NA	NA	NA	NA	NA	\$19.99	
NRC - Add'l	SATCO	NA	\$3.87	NA	NA	NA	NA	NA	NA	NA	
NRC - Manual Svc Order, per LSR	SOMECS	\$3.50	\$2.77	\$3.50	NA	\$3.50	NA	\$3.50	\$3.50	\$3.50	
NRC - Manual Svc Order, per LSR disconnect	SOMAN	NA	\$0.43	NA	NA	NA	NA	NA	NA	NA	
NRC - Electronic Svc Order, per LSR	SOMAN	\$15.61	NA	\$14.91	NA	\$13.71	NA	\$25.51	\$25.59	NA	
NRC - Electronic Svc Order, per LSR disconnect	SOMAN	\$7.39	NA	\$6.63	NA	\$6.09	NA	\$8.37	\$8.92	NA	
Channel System - Incremental Cost - Manual Svc. Order vs. Electronic -1st	SOMAN	\$71.76	NA	\$10.82	NA	\$9.94	NA	NA	NA	NA	
Channel System - Incremental Cost - Manual Svc. Order vs. Electronic -Add'l	SOMAN	\$52.03	NA	NA	NA	NA	NA	NA	NA	NA	
DS3 Channelization (DS3 to DS1) - Kentucky & Mississippi											
per Channelized System (28 DS1) per month	SATNS	NA	NA	NA	\$303.33	NA	\$247.40	NA	NA	NA	

Version 2Q00: 7/17/00

BELLSOUTH/LEVEL 3 RATES
LOCAL INTERCONNECTION

			RATES BY STATE									
DESCRIPTION	USOC	AL	FL	GA	KY	LA	MS	NC	SC	TN		
NRC - 1st	SATNS	NA	NA	NA	NA	NA	\$79.94	NA	NA	NA		
NRC - Add'l	SATNS	NA	NA	NA	NA	NA	\$65.20	NA	NA	NA		
NRC -1st - Disconnect	SATNS	NA	NA	NA	\$8.52	NA	\$5.58	NA	NA	NA		
NRC -Add'l - Disconnect	SATNS	NA	NA	NA	\$15.86	NA	\$15.85	NA	NA	NA		
per Interface per month (COCI)	SATCO	NA	NA	NA	\$11.36	NA	\$11.35	NA	NA	NA		
NRC - 1st	SATCO	NA	NA	NA	\$19.99	NA	NA	NA	NA	NA		
NRC - Add'l	SATCO	NA	NA	NA	NA	NA	NA	NA	NA	NA		
NRC - Manual Svc Order, per LSR	SOMAN	NA	NA	NA	\$3.50	NA	\$3.50	NA	NA	NA		
NRC - Manual Svc Order, per LSR disconnect	SOMAN	NA	NA	NA	NA	NA	NA	NA	NA	NA		
NRC - Electronic Svc Order, per LSR	SOMECS	NA	NA	NA	NA	NA	\$26.95	NA	NA	NA		
NRC - Electronic Svc Order, per LSR disconnect	SOMECS	NA	NA	NA	NA	NA	\$11.98	NA	NA	NA		
Channel System - Incremental Cost - Manual Svc. Order vs. Electronic -1st	SOMAN	NA	NA	NA	NA	NA	\$16.97	NA	NA	NA		
Channel System - Incremental Cost - Manual Svc. Order vs. Electronic -Add'l	SOMAN	NA	NA	NA	NA	NA	NA	NA	NA	NA		
DS1 Channelization (DS1 to DS0)												
per Channelized System (24 DS0) per month	SATC1	\$136.82	\$154.74	\$126.22	NA	\$126.66	NA	\$158.01	\$147.51	\$165.21		
NRC - 1st	SATC1	\$197.98	\$183.57	\$200.39	NA	\$184.35	NA	\$228.01	\$220.89	\$197.21		
NRC - Add'l	SATC1	\$123.12	\$126.16	\$124.93	NA	\$114.94	NA	\$141.88	\$137.15	\$119.99		
NRC -1sr - Disconnect	SATC1	\$11.67	\$19.68	\$28.95	NA	\$28.86	NA	\$34.55	NA	\$25.66		
NRC -Add'l - Disconnect	SATC1	\$0.95	\$18.29	\$18.43	NA	\$18.37	NA	\$21.14	NA	\$15.81		
- Interface (COCI)												
per OCU-DP(data) card per month (2.4-64kbs)	SATSA	\$1.66	\$2.22	\$1.06	NA	\$1.94	NA	\$2.03	\$2.34	\$2.46		
NRC - 1st	SATSA	\$12.05	\$13.26	\$12.15	NA	\$11.18	NA	\$12.39	\$12.05	\$12.61		
NRC - Add'l	SATSA	\$8.69	\$9.50	\$8.76	NA	\$8.06	NA	\$8.93	\$8.68	\$9.03		
per BRITE card per month	SATSA	\$3.41	\$3.86	\$3.41	NA	\$4.18	NA	\$3.76	\$4.21	\$3.33		
NRC - 1st	SATSA	\$12.05	\$13.26	\$12.15	NA	\$12.29	NA	\$15.76	\$12.05	\$12.61		
NRC - Add'l	SATSA	\$8.69	\$9.50	\$8.76	NA	\$8.80	NA	\$11.28	\$8.68	\$9.03		
per VG card per month (DS0)	SATSA	\$0.86	\$1.46	\$2.20	NA	\$1.06	NA	\$1.28	\$1.47	\$1.25		
NRC - 1st	SATSA	\$12.05	\$13.26	\$12.15	NA	\$11.18	NA	\$12.39	\$12.05	\$12.61		
NRC - Add'l	SATSA	\$8.69	\$9.50	\$8.76	NA	\$8.06	NA	\$8.93	\$8.68	\$9.03		
NRC - Manual Svc Order, per LSR	SOMAN	NA	\$21.73	NA	NA	NA	NA	NA	NA	\$19.99		
NRC - Manual Svc Order, per LSR disconnect	SOMAN	NA	\$3.87	NA	NA	NA	NA	NA	NA	NA		
NRC - Electronic Svc Order, per LSR	SOMECS	\$3.50	\$2.77	\$3.50	NA	\$3.50	NA	\$3.50	\$3.50	\$3.50		
NRC - Electronic Svc Order, per LSR disconnect	SOMECS	NA	\$0.43	NA	NA	NA	NA	NA	NA	NA		
Channel System - Incremental Cost - Manual Svc. Order vs. Electronic -1st	SOMAN	\$15.61	NA	\$14.91	NA	\$13.71	NA	\$25.51	\$25.59	NA		
Channel System - Incremental Cost - Manual Svc. Order vs. Electronic -Add'l	SOMAN	\$7.39	NA	\$6.63	NA	\$6.09	NA	\$8.37	\$8.92	NA		
Incremental Cost-Manual Svc. Order vs. Elect -Disconnect - 1st	SOMAN	\$30.18	NA	\$10.82	NA	\$9.94	NA	NA	NA	NA		
Incremental Cost-Manual Svc. Order vs. Elect -Disconnect - Add'l	SOMAN	\$18.86	NA	NA	NA	NA	NA	NA	NA	NA		
DS1 Channelization (DS1 to DS0) - Kentucky & Mississippi												
per Channelized System (24 DS0) per month	SASTN1	NA	NA	NA	\$200.01	NA	\$146.87	NA	NA	NA		
NRC - 1st	SASTN1	NA	NA	NA	\$302.82	NA	\$271.52	NA	NA	NA		
NRC - Add'l	SASTN1	NA	NA	NA	\$184.20	NA	\$164.56	NA	NA	NA		
NRC -1sr - Disconnect	SASTN1	NA	NA	NA	NA	NA	\$36.38	NA	NA	NA		
NRC -Add'l - Disconnect	SASTN1	NA	NA	NA	NA	NA	\$22.82	NA	NA	NA		
- Interface (COCI)												
per OCU-DP(data) card per month (2.4-64kbs)	SATSA	NA	NA	NA	\$2.94	NA	\$2.86	NA	NA	NA		
NRC - 1st	SATSA	NA	NA	NA	\$15.86	NA	\$15.85	NA	NA	NA		
NRC - Add'l	SATSA	NA	NA	NA	\$11.36	NA	\$11.35	NA	NA	NA		
per BRITE card per month	SATSA	NA	NA	NA	\$4.04	NA	\$3.88	NA	NA	NA		
NRC - 1st	SATSA	NA	NA	NA	\$15.86	NA	\$15.85	NA	NA	NA		

Version 2Q00: 7/17/00

BELLSOUTH/LEVEL 3 RATES
LOCAL INTERCONNECTION

		RATES BY STATE									
DESCRIPTION	USOC	AL	FL	GA	KY	LA	MS	NC	SC	TN	
NRC - Add'l	SATSA	NA	NA	NA	\$11.36	NA	\$11.35	NA	NA	NA	
per VG card per month (DS0)	SATSA	NA	NA	NA	\$1.40	NA	\$1.45	NA	NA	NA	
NRC - 1st	SATSA	NA	NA	NA	\$15.86	NA	\$15.85	NA	NA	NA	
NRC - Add'l	SATSA	NA	NA	NA	\$11.36	NA	\$11.35	NA	NA	NA	
NRC - Manual Svc Order, per LSR	SOMAN	NA	NA	NA	\$19.99	NA	NA	NA	NA	NA	
NRC - Manual Svc Order, per LSR disconnect	SOMAN	NA	NA	NA	NA	NA	NA	NA	NA	NA	
NRC - Electronic Svc Order, per LSR	SOMECA	NA	NA	NA	\$3.50	NA	\$3.50	NA	NA	NA	
NRC - Electronic Svc Order, per LSR disconnect	SOMECA	NA	NA	NA	NA	NA	NA	NA	NA	NA	
Channel System - Incremental Cost - Manual Svc. Order vs. Electronic -1st	SOMAN	NA	NA	NA	NA	NA	\$26.95	NA	NA	NA	
Channel System - Incremental Cost - Manual Svc. Order vs. Electronic -Add'l	SOMAN	NA	NA	NA	NA	NA	\$11.98	NA	NA	NA	
Incremental Cost-Manual Svc. Order vs. Elect -Disconnect - 1st	SOMAN	NA	NA	NA	NA	NA	\$16.97	NA	NA	NA	
Incremental Cost-Manual Svc. Order vs. Elect -Disconnect - Add'l	SOMAN	NA	NA	NA	NA	NA	NA	NA	NA	NA	
Local Interconnection Mid-Span Meet											
Local Channel - Dedicated - DS1											
DS1 Monthly Recurring per month	TEFHG	\$17.76	\$22.18	\$19.18	\$21.90	\$21.90	\$19.46	\$17.85	\$18.60	\$20.14	
NRC - DS1 - 1st	TEFHG	\$251.79	\$123.25	\$178.08	\$269.48	\$174.28	\$247.42	\$268.83	\$267.41	\$138.68	
NRC - DS1 - Add'l	TEFHG	\$221.42	\$115.25	\$156.45	\$232.47	\$150.15	\$217.64	\$232.73	\$231.41	\$116.63	
NRC - DS1 - Disconnect Chg - 1st	TEFHG	\$23.14	NA	NA	NA	\$12.08	\$23.43	NA	NA	\$16.59	
NRC - DS1 - Disconnect Chg - Add'l	TEFHG	\$16.09	NA	NA	NA	\$10.66	\$16.51	NA	NA	\$11.15	
NRC - DS1 - Incremental Charge-Manual Svc Order - 1st	SOMAC	\$61.95	NA	\$44.22	\$87.71	\$42.34	\$59.58	\$623.92	\$87.99	\$45.68	
NRC - DS1 - Incremental Charge-Manual Svc Order - Add'l	SOMAC	\$0.00	NA	NA	NA	NA	NA	\$467.22	\$3.11	\$1.76	
NRC - DS1 - Incremental Charge-Manual Svc Order-Disconnect	SOMAC	\$29.27	NA	NA	NA	\$19.48	\$27.51	NA	NA	\$21.75	
NOTES:											
If no rate is identified in the contract, the rate for the specific service or function will be as set forth in applicable BellSouth tariff or as negotiated by the parties upon request by either party.											

Physical Collocation

BELLSOUTH PHYSICAL COLLOCATION

1. SCOPE OF ATTACHMENT

1.1 Scope of Attachment. The rates, terms, and conditions contained within this Attachment shall only apply when Level 3 is occupying the collocation space as a sole occupant or as a Host pursuant to Section 4.

1.2 Right to occupy. Subject to Section 4 of this Attachment, BellSouth hereby grants to Level 3 a right to occupy that certain area designated by BellSouth within a BellSouth central office premises, of a size which is specified by Level 3 and agreed to by BellSouth (hereinafter "Collocation Space"). Notwithstanding the foregoing, BellSouth shall consider in its designation for cageless collocation any unused space within the BellSouth central office premises. The size specified by Level 3 may contemplate a request for space sufficient to accommodate Level 3's growth within a two year period unless otherwise agreed to by the Parties.

1.2.1 Space Reclamation. In the event of space exhaust within a central office premises, Level 3 may be required to release unused space to BellSouth to be allocated to other physical collocation applicants when 100% of the space in Level 3's collocation arrangement is not being utilized by the end of the second year of operation. Level 3 will first have the option of subleasing any amount of space not being utilized pursuant to this sub-Section in lieu of releasing space to BellSouth. Prior to reclaiming any such unused space BellSouth shall notify Level 3 of its intent in writing. Level 3 will respond to BellSouth within fourteen (14) calendar days of receipt of BellSouth's notice. Said response shall detail Level 3's current use or planned use of remaining space within the subsequent three (3) months, either by placing Level 3 equipment in the remaining space or the subleasing of such Collocation Space. If BellSouth disagrees with Level 3's assertions it may avail itself of the Dispute Resolution procedures set forth in the General Terms and Conditions section of this Agreement.

1.3 Use of Space. Level 3 shall use the Collocation Space for the purposes of installing, maintaining and operating Level 3's equipment (to include testing and monitoring equipment) used or useful primarily to interconnect with BellSouth services and facilities, including access to unbundled network elements, for the provision of telecommunications services. Pursuant to Section 5 following, Level 3 may at its option, place Level 3-owned or leased fiber entrance facilities to the Collocation Space. In addition to, and not in lieu of, interconnection to BellSouth services and facilities, Level 3 may connect to other collocators within the designated BellSouth Central Office (including to its other virtual or physical collocated arrangements) through co-carrier cross connect facilities designated by Level 3 pursuant to section 5.6 following. The Collocation Space may be used for no other purposes except as specifically described herein or authorized in writing by BellSouth.

1.4 Rates and charges. Level 3 agrees to pay the rates and charges identified at Exhibit A attached hereto. Rates marked with an asterisk are interim and subject to true-up pursuant to Section 7.7.

2. SPACE NOTIFICATION

2.1 Availability of Space. Upon submission of an application pursuant to Section 6, BellSouth will provide Level 3 physical collocation, pursuant to the terms of this Attachment, at any BellSouth central office premises, unless BellSouth is prepared to demonstrate to the state Public Service Commission that there is no space available due to space limitations or no space available due to technical infeasibility. BellSouth will respond to an application within ten (10) business days as to whether space is available or not available within a BellSouth central office premises.. BellSouth shall, upon request from Level 3, remove obsolete unused equipment from its premises prior to BellSouth's scheduled removal of such equipment, to increase the amount of space available for collocation. Level 3 shall pay a share of equipment removal costs that is proportionate to its share of the space that is made available by the removal of equipment ("proportionate share").

2.2 Reporting. Upon request from Level 3, BellSouth will provide a written report specifying the amount of collocation space available at the central office premises requested, the number of collocators present at the central office premises, any modifications in the use of the space since the last report or the central office premises requested and the measures BellSouth is taking to make additional space available for collocation arrangements.

2.2.1 The request from Level 3 must be written and must include the central office premises and Common Language Location Identification (CLLI) code of the central office premises. Such information regarding central office premises and CLLI code is located in the National Exchange Carriers Association (NECA) Tariff FCC No. 4.

2.2.2 BellSouth will respond to a request for a particular Central Office location within ten (10) business days of receipt of such request. BellSouth will make best efforts to respond in ten (10) business days to such a request when the request includes up to and including five (5) Central Office locations within the same state. The response time for requests of more than five (5) shall be negotiated between the Parties. If BellSouth cannot meet the ten business day response time, for the second through fifth requests, BellSouth shall notify Level 3 and inform Level 3 of the time frame under which it can respond, which shall be as soon as reasonably possible.

2.3 Denial of Application. After notifying Level 3 that BellSouth has no available space in the requested Central Office ("Denial of Application"), BellSouth will allow Level 3, upon request, to tour the entire Central Office within ten (10) business days of such Denial of Application. In order to schedule said tour within ten (10) business days, the request for a tour of the Central Office must be received by BellSouth within five (5) business days of the Denial of Application.

2.4 Filing of Petition for Waiver. Upon Denial of Application BellSouth will timely file a petition with the Commission pursuant to 47 U.S.C. § 251(c)(6).

2.5 Waiting List. On a first come first served basis, BellSouth will maintain a waiting list of requesting carriers who have either received a Denial of Application or, where it is publicly known that the central office premises is out of space, have submitted a Letter of Intent to collocate. BellSouth will notify the telecommunications carriers on the waiting list when space becomes available according to how much space becomes available and the position of telecommunications carrier on said waiting list. Upon request BellSouth will advise Level 3 as to its position on the list.

2.6 Public Notification. BellSouth will maintain on its Interconnection Services website a notification document that will indicate all central office premises that are without available space. BellSouth shall update such document within ten (10) business days of the Denial of Application date. BellSouth will also post a document on its Interconnection Services website that contains a general notice where space has become available in a Central Office previously on the space exhaust list. BellSouth shall allocate said available space pursuant to the waiting list referenced in Section 2.5.

2.7 State Agency Procedures. Notwithstanding the foregoing, should any state regulatory agency impose a procedure different than procedures set forth in this section, that procedure shall supersede the requirements set forth herein.

3. COLLOCATION OPTIONS

3.1 Cageless. Except where local building code does not allow cageless collocation, BellSouth shall provide Level 3 collocation for Level 3's equipment and facilities without requiring the construction of a cage or similar structure and without requiring the creation of a separate entrance to the Collocation Space. BellSouth shall allow Level 3 to have direct access to its equipment and facilities but may require Level 3 to use a central entrance to the BellSouth Central Office. BellSouth shall make cageless collocation available in single bay increments pursuant to Section 7. Except where Level 3's equipment requires special technical considerations (e.g., special cable racking, isolated ground plane), BellSouth shall assign cageless Collocation Space in conventional equipment rack lineups where feasible. For equipment requiring special technical considerations, Level 3 must provide the equipment layout, including spatial dimensions for such equipment pursuant to generic requirements contained in BellCore (Telcordia) GR-63-Core and shall be responsible for constructing all special technical requirements associated with such equipment pursuant to Section 6.5 following.

3.2 Cages and Adjacent Arrangement Enclosures. BellSouth shall authorize the enclosure of Level 3's equipment and facilities at Level 3's option or if required by local building code. Level 3 must arrange with a BellSouth certified contractor to construct a collocation arrangement enclosure in accordance with BellSouth's guidelines and specifications and at its sole expense. BellSouth will provide guidelines and specifications upon request. Where local building codes require enclosure specifications more stringent than BellSouth's standard enclosure specification, Level 3 and Level 3's BellSouth certified contractor must comply with local building code requirements. Level 3's BellSouth certified contractor shall be responsible for filing and receiving any and all necessary permits and/or licenses for such construction. The Certified Vendor shall bill Level 3 directly for all work performed for Level 3 pursuant to

this Attachment and BellSouth shall have no liability for nor responsibility to pay such charges imposed by the Certified Vendor. Level 3 must provide the local BellSouth building_contact with two Access Keys used to enter the locked enclosure. Except in case of emergency, BellSouth will not access Level 3's locked enclosure prior to notifying Level 3.

3.2.1 BellSouth has the right to review Level 3's plans and specifications prior to allowing construction to start. BellSouth has the right to inspect the enclosure after construction to make sure it is designed and constructed according to BellSouth's guidelines and specifications and to require Level 3 to remove or correct at Level 3's cost any structure that does not meet these standards. A copy of BellSouth's guidelines and specifications will be provided to Level 3 upon execution of this Agreement. BellSouth must provide Level 3 prior notice of any changes to such guidelines and specifications. Notwithstanding the foregoing, nothing in BellSouth's guidelines or specifications supercedes Level 3's substantive rights under this Agreement.

3.3 Shared (Subleased) Caged Collocation. Level 3 may allow other telecommunications carriers to share Level 3's caged collocation arrangement pursuant to terms and conditions agreed to by Level 3 ("Host") and other telecommunications carriers ("Guests") and pursuant to this section with the following exceptions: (1) where local building code does not allow Shared (Subleased) Caged Collocation and (2) where the BellSouth central office premises is located within a leased space and BellSouth is not authorized by the lessor to offer such an option. The terms and conditions of the agreement between the Host and its Guests shall be written and a copy provided, on a confidential basis, to the BellSouth contact specified in Section 15 within ten (10) business days of the Guest's application and prior to any Firm Order. Further, said agreement shall incorporate by reference the rates, terms, and conditions of this Attachment between BellSouth and Level 3.

3.3.1 Level 3 shall be the sole interface and responsible party to BellSouth for the purpose of submitting applications for initial and additional equipment placements of Guest; for assessment of rates and charges contained within this Attachment; and for the purposes of ensuring that the safety and security requirements of this Attachment are fully complied with by the Guest, its employees and agents. In the event the Host and Guest jointly submit an initial Application, only one Application Fee will be assessed. A separate initial Guest application shall require the assessment of a Subsequent Application Fee, as set forth in Exhibit A, if this application is not the initial application made for the arrangement. Notwithstanding the foregoing, Guest may arrange directly with BellSouth for the provision of the interconnecting facilities between BellSouth and Guest and for the provisions of the services and access to unbundled network elements.

3.3.2 Level 3 shall indemnify and hold harmless BellSouth from any and all claims, actions, causes of action, of whatever kind or nature arising out of the presence of Level 3's Guests in the Collocation Space, except for claims, action, causes of action, of whatever kind or nature arising out of or related to the interconnection between BellSouth and the Guests or BellSouth's provision of access to Unbundled Network Elements to the Guests directly.

3.4 Adjacent Collocation. BellSouth will provide adjacent collocation arrangements ("Adjacent Arrangement") where space within the Central Office is legitimately exhausted, subject to technical feasibility, where the Adjacent Arrangement does not interfere with access

to existing or planned structures or facilities on the Central Office property and where permitted by zoning and other applicable state and local regulations. The Adjacent Arrangement shall be constructed or procured by Level 3 and in conformance with BellSouth's design and construction specifications. Further, Level 3 shall construct, procure, maintain and operate said Adjacent Arrangement(s) pursuant to all of the terms and conditions set forth in this Attachment. Rates shall be negotiated at the time of the request for Adjacent Collocation.

3.4.1 Should Level 3 elect such option, Level 3 must arrange with a BellSouth certified contractor to construct an Adjacent Arrangement structure in accordance with BellSouth's guidelines and specifications. BellSouth will provide guidelines and specifications upon request. Where local building codes require enclosure specifications more stringent than BellSouth's standard specification, Level 3 and Level 3's contractor must comply with local building code requirements. Level 3's contractor shall be responsible for filing and receiving any and all necessary zoning, permits and/or licenses for such construction. Level 3's BellSouth Certified Vendor shall bill Level 3 directly for all work performed for Level 3 pursuant to this Attachment and BellSouth shall have no liability for nor responsibility to pay such charges imposed by the Certified Vendor. Level 3 must provide the local BellSouth building contact with two cards, keys or other access device used to enter the locked enclosure. Except in cases of emergency, BellSouth shall not access Level 3's locked enclosure prior to notifying Level 3.

3.4.2 BellSouth maintains the right to review Level 3's plans and specifications prior to construction of an Adjacent Arrangement(s). BellSouth may inspect the Adjacent Arrangement(s) following construction and prior to commencement, as defined in Section 4.1 following, to ensure the design and construction comply with BellSouth's guidelines and specifications. BellSouth may require Level 3, at Level 3's sole cost, to correct any deviations from BellSouth's guidelines and specifications found during such inspection(s), up to and including removal of the Adjacent Arrangement, within five (5) business days of BellSouth's inspection, unless the Parties mutually agree to an alternative time frame.

3.4.3 Level 3 shall provide a concrete pad, the structure housing the arrangement, HVAC, lighting, and all facilities that connect the structure (i.e. racking, conduits, etc.) to the BellSouth point of interconnection. At Level 3's option, BellSouth shall provide an AC power source and access to physical collocation services and facilities subject to the same nondiscriminatory requirements as applicable to any other physical collocation arrangement.

3.4.4 BellSouth shall allow Shared (Subleased) Caged Collocation within an Adjacent Arrangement pursuant to the terms and conditions set forth in Section 3.3 proceeding.

3.5 Level 3 may seek a particular physical collocation arrangement, and is entitled to a presumption that such arrangement is technically feasible if any local exchange company has deployed such collocation arrangement in any incumbent local exchange carrier premises.

4. OCCUPANCY

4.1 Commencement Date. The "Commencement Date" shall be the day Level 3's equipment becomes operational as described in Article 4.2, following.

4.2 Occupancy. BellSouth will notify Level 3 in writing that the Collocation Space is ready for occupancy within 10 business days of the date the space is ready for occupancy. Level 3 must place operational telecommunications equipment in the Collocation Space and connect with BellSouth's network within one hundred eighty (180) days after receipt of such notice. Level 3 must notify BellSouth in writing that collocation equipment installation is complete and is operational with BellSouth's network. BellSouth may, at its option, not accept orders for interconnected service until receipt of such notice. If Level 3 fails to place operational telecommunications equipment in the Collocation Space within 180 calendar days and such failure continues for a period of thirty (30) days after receipt of written notice from BellSouth, then and in that event Level 3's right to occupy the Collocation Space terminates and BellSouth shall have no further obligations to Level 3 with respect to said Collocation Space. However, for good cause shown, Level 3 may request and BellSouth will grant, an extension of up to 30 days. Termination of Level 3's rights to the Collocation Space pursuant to this paragraph shall not operate to release Level 3 from its obligation to reimburse BellSouth for all costs reasonably incurred by BellSouth in preparing the Collocation Space, but rather such obligation shall survive this Attachment. To the extent BellSouth places a subsequent collocator in the Collocation Space within one year of the date Level 3's right to occupy said Collocation Space terminates, BellSouth shall reimburse Level 3 an amortized amount of the costs incurred by BellSouth in preparing the Collocation Space based upon the amount of time the Collocation Space was unoccupied pursuant to this paragraph until its occupancy by the subsequent collocator. For purposes of this paragraph, Level 3's telecommunications equipment will be deemed operational when cross-connected to BellSouth's network for the purpose of service provision.

4.3 Termination. Except where otherwise agreed to by the Parties, Level 3 may terminate occupancy in a particular Collocation Space upon thirty (30) days prior written notice to BellSouth. Upon termination of such occupancy, Level 3 at its expense shall remove its equipment and other property from the Collocation Space. Level 3 shall have thirty (30) days from the termination date to complete such removal, including the removal of all equipment and facilities of Level 3's Guests; provided, however, that Level 3 shall continue payment of monthly fees to BellSouth until such date as Level 3 has fully vacated the Collocation Space. Should Level 3 fail to vacate the Collocation Space within thirty (30) days from the termination date, BellSouth shall have the right to remove the equipment and other property of Level 3 at Level 3's expense and with no liability for damage or injury to Level 3's property unless caused by the gross negligence or intentional misconduct of BellSouth. Upon expiration of this Attachment, Level 3 shall surrender the Collocation Space to BellSouth in the same condition as when first occupied by the Level 3 except for ordinary wear and tear. Level 3 shall be responsible for the cost of removing any enclosure, together with all support structures (e.g., racking, conduits), of an Adjacent Collocation arrangement at the termination of occupancy and restoring the grounds to their original condition, except for ordinary wear and tear.

5. USE OF COLLOCATION SPACE

5.1 Equipment Type. BellSouth permits the collocation of any type of equipment used or useful for interconnection to BellSouth's network or for access to unbundled network elements in the provision of telecommunications services. Such equipment used or useful for interconnection and access to unbundled network elements includes, but is not limited to transmission equipment including, but not limited to, optical terminating equipment and

multiplexers, and digital subscriber line access multiplexers, routers, asynchronous transfer mode multiplexers, and remote switching modules. Nothing in this section requires BellSouth to permit collocation of equipment used solely to provide enhanced services; provided, however, that BellSouth may not place any limitations on the ability of requesting carriers to use all the features, functions, and capabilities of equipment collocated pursuant to this section.

5.1.1 Such equipment must at a minimum meet the following BellCore (Telcordia) Network Equipment Building Systems (NEBS) General Equipment Requirements: Criteria Level 1 requirements as outlined in the BellCore (Telcordia) Special Report SR-3580, Issue 1; equipment design spatial requirements per GR-63-CORE, Section 2; thermal heat dissipation per GR-063-CORE, Section 4, Criteria 77-79; acoustic noise per GR-063-CORE, Section 4, Criterion 128, and National Electric Code standards. If BellSouth denies collocation of Level 3's equipment citing safety standards, BellSouth must provide to Level 3 within (5) five business days of the denial a list of all equipment that BellSouth locates within the premises in question together with an affidavit attesting that all of the equipment meets or exceeds the safety standard that BellSouth contends Level 3's equipment fails to meet.

5.1.2 Level 3 shall not use the Collocation Space for marketing purposes nor shall it place any identifying signs or markings in the area surrounding the Collocation Space or on the grounds of the central office premises.

5.1.3 Level 3 shall place a plaque or other identification affixed to Level 3's equipment necessary to identify Level 3's equipment, including a list of emergency contacts with telephone numbers.

5.2 Entrance Facilities. Level 3 may elect to place Level 3-owned or Level 3-leased fiber entrance facilities into the Collocation Space. BellSouth will designate the point of interconnection in close proximity to the Central Office building housing the Collocation Space, such as an entrance manhole or a cable vault which are physically accessible by both parties. Level 3 will provide and place fiber cable at the point of interconnection of sufficient length to be pulled through conduit and into the splice location. Level 3 will provide and install a sufficient length of fire retardant riser cable, to which the entrance cable will be spliced, which will extend from the splice location to the Level 3's equipment in the Collocation Space. In the event Level 3 utilizes a non-metallic, riser-type entrance facility, a splice will not be required. Level 3 must contact BellSouth for instructions prior to placing the entrance facility cable in the manhole. Level 3 is responsible for maintenance of the entrance facilities At Level 3's option BellSouth will accommodate where technically feasible a microwave entrance facility pursuant to separately negotiated terms and conditions.

5.2.1 Dual Entrance. BellSouth will provide at least two interconnection points at each central office premises where there are at least two such interconnection points available and where capacity exists. Upon receipt of a request for physical collocation under this Attachment, BellSouth shall provide Level 3 with information regarding BellSouth's capacity to accommodate dual entrance facilities. If conduit in the serving manhole(s) is available and is not reserved for another purpose for utilization within 12 months of the receipt of an application for collocation, BellSouth will make the requested conduit space available for installing a second entrance facility to Level 3's arrangement. The location of the serving manhole(s) will be determined at the sole discretion of BellSouth. Where dual entrance is not available due to lack of capacity, BellSouth will so state in the Application Response.

5.2.2 Shared Use. Level 3 may utilize spare capacity on an existing Interconnector entrance facility for the purpose of providing an entrance facility to another Level 3 collocation arrangement within the same BellSouth Central Office. Level 3 must arrange with BellSouth for BellSouth to splice the utilized entrance facility capacity to Level 3-provided riser cable.

5.3 Splicing in the Entrance Manhole. Although not generally permitted, should Level 3 request a splice to occur in the entrance manhole(s), BellSouth, at its sole discretion, may grant such a request, provided that BellSouth will not unreasonably withhold approval of requests to make such a splice. When the request for a splice is granted to Level 3 by BellSouth, Level 3 shall ensure its employees or agents entering and/or performing work in the entrance manhole(s) are trained and comply with BellSouth procedures and OSHA requirements regarding access to manholes and that BellSouth personnel are notified and present for all entrances and work performed in the entrance manhole(s). Manhole covers shall be properly closed and secured at the conclusion of entry and/or work. Advance notification to BellSouth shall occur at a minimum of 48 hours prior to desired entry for normal work activities and at a minimum of 2 hours prior to desired entry in an out of service condition.

5.4 Demarcation Point. BellSouth will designate the point(s) of interconnection between Level 3's equipment and/or network and BellSouth's network. Each party will be responsible for maintenance and operation of all equipment/facilities on its side of the demarcation point. For 2-wire and 4-wire connections to BellSouth's network, the demarcation point shall be a common block on the BellSouth designated conventional distributing frame. Level 3 shall be responsible for providing, and Level 3's BellSouth Certified Vendor shall be responsible for installing and properly labeling/stenciling, the common block, and necessary cabling pursuant to Section 6.4. For all other terminations BellSouth shall designate a demarcation point on a per arrangement basis. Level 3 or its agent must perform all required maintenance to equipment/facilities on its side of the demarcation point, pursuant to subsection 5.5, following, and may self-provision cross-connects that may be required within the collocation space to activate service requests. At Level 3's option, a Point of Termination (POT) bay or frame may be placed in the Collocation Space.

5.5 Level 3's Equipment and Facilities. Level 3, or if required by this Attachment, Level 3's BellSouth certified vendor, is solely responsible for the design, engineering, installation, testing, provisioning, performance, monitoring, maintenance and repair of the equipment and facilities used by Level 3. Such equipment and facilities may include but are not limited to cable(s); equipment; and point of termination connections.

5.6 Co-Carrier Cross-connect. In addition to, and not in lieu of, obtaining interconnection with, or access to, BellSouth telecommunications services, unbundled network elements, and facilities, Level 3 may directly connect to other Interconnectors within the designated BellSouth Central Office (including to its other virtual or physical collocated arrangements) through facilities owned by Level 3, or the other Interconnector(s) Level 3 is directly connecting to, or through BellSouth facilities designated by Level 3, at Level 3's option. Such connections to other carriers may be made using either optical or electrical facilities. Level 3 may deploy such optical or electrical connections directly between its own facilities and the facilities of other Interconnector(s) without being routed through BellSouth equipment.

5.6.1 If Level 3 requests a co-Carrier cross-connect after the initial installation, Level 3 must submit an application and the non-recurring charge as specified in Exhibit A shall apply.. Level 3 must use a Certified Vendor to place the co-Carrier cross connect, except in cases where the Level 3 equipment and the equipment of the other Interconnector are located within contiguous collocation spaces. In cases where Level 3's equipment and the equipment of the other Interconnector are located in contiguous collocation spaces, Level 3 will have the option to deploy the co-Carrier cross connects between the sets of equipment.

5.7 Easement Space. From time to time BellSouth may require access to the Collocation Space. BellSouth retains the right to access such space for the purpose of making BellSouth equipment and building modifications (e.g., running, altering or removing racking, ducts, electrical wiring, HVAC, and cables). BellSouth will give reasonable notice to Level 3 when access to the Collocation Space is required. Level 3 may elect to be present whenever BellSouth performs work in the Collocation Space. The Parties agree that Level 3 will not bear any of the expense associated with this work.

5.8 Access. Pursuant to Section 11, Level 3 shall have access to the Collocation Space twenty-four (24) hours a day, seven (7) days a week. Level 3 agrees to provide the name, social security number, and date of birth of each employee, contractor, or agents provided with Access Keys or cards ("Access Keys") prior to the issuance of said Access Keys. Access Keys shall not be duplicated under any circumstances. Level 3 agrees to be responsible for all Access Keys and for the return of all said Access Keys in the possession of Level 3 employees, contractors, Guests, or agents after termination of the employment relationship, contractual obligation with Level 3 or upon the termination of this Attachment or the termination of occupancy of an individual collocation arrangement.

5.8.1 Lost or Stolen Access Keys. Level 3 shall notify BellSouth in writing immediately in the case of lost or stolen Access Keys. Level 3 will pay BellSouth \$250.00 per Access Key(s) lost or stolen. Should it become necessary for BellSouth to re-key buildings as a result of a lost Access Key(s) or for failure to return an Access Key(s), Level 3 shall pay for all reasonable costs associated with the re-keying.

5.9 Interference or Impairment. Notwithstanding any other provisions of this Attachment, equipment and facilities placed in the Collocation Space shall not interfere with or impair service provided by BellSouth or by any other Interconnector located in the Central Office; shall not endanger or damage the facilities of BellSouth or of any other Interconnector, the Collocation Space, or the Central Office; shall not compromise the privacy of any communications carried in, from, or through the Central Office; and shall not create an unreasonable risk of injury or death to any individual or to the public. If BellSouth reasonably determines that any equipment or facilities of Level 3 violates the provisions of this paragraph, BellSouth shall give written notice to Level 3, which notice shall direct Level 3 to cure the violation within forty-eight (48) hours of Level 3's actual receipt of written notice or, at a minimum, to commence curative measures within 24 hours and to exercise reasonable diligence to complete such measures as soon as possible thereafter. After receipt of the notice, the parties agree to consult immediately and, if necessary, to inspect the arrangement. If Level 3 fails to take curative action within 48 hours or if the violation is of a character which poses an immediate and substantial threat of damage to property, injury or death to any person, or interference/impairment of the services provided by BellSouth or any other interconnector, then and only in that event BellSouth may take such action as it deems appropriate to correct the violation, including without limitation the interruption of electrical

power to Level 3's equipment. BellSouth will endeavor, but is not required, to provide notice to Level 3 prior to taking such action and shall have no liability to Level 3 for any damages arising from such action, except to the extent that such action by BellSouth constitutes willful misconduct or gross negligence.

5.10 Personalty and its Removal. Subject to requirements of this Attachment, Level 3 may place or install in or on the Collocation Space such facilities and equipment, including storage for and spare equipment, as it deems desirable for the conduct of business; Provided that such equipment is telecommunications equipment, does not violate floor loading requirements, imposes or could impose or contains or could contain environmental conditions or hazards. Personal property, facilities and equipment placed by Level 3 in the Collocation Space shall not become a part of the Collocation Space, even if nailed, screwed or otherwise fastened to the Collocation Space, but shall retain their status as personalty and may be removed by Level 3 at any time. Any damage caused to the Collocation Space by Level 3's employees, agents or representatives during the removal of such property shall be promptly repaired by Level 3 at its expense.

5.11 Alterations. In no case shall Level 3 or any person acting on behalf of Level 3 make any material rearrangement, modification, improvement, addition, repair, or other alteration to the Collocation Space or the BellSouth Central Office without the written consent of BellSouth, which consent shall not be unreasonably withheld. The cost of any such specialized alterations shall be paid by Level 3. Any material rearrangement, modification, improvement, addition, repair, or other alteration shall require a Subsequent Application and fee, pursuant to sub-section 6.1.2.

5.12 Janitorial Service. Level 3 shall be responsible for the general upkeep and cleaning of the Caged Collocation Space and shall arrange directly with a BellSouth certified contractor for janitorial services. BellSouth shall provide a list of such contractors on a site-specific basis upon request.

6. ORDERING AND PREPARATION OF COLLOCATION SPACE

6.1 Application for Space. Level 3 shall submit an application document when Level 3 or Level 3's Guest(s), as defined in Section 3.3, desires to request or modify the use of the Collocation Space.

6.1.1 Initial Application. For Level 3 or Level 3's Guest(s) initial equipment placement, Level 3 shall submit to BellSouth a complete and accurate Application and Inquiry document (Bona Fide Application), together with payment of the Application Fee as stated in Exhibit A. The Bona Fide Application shall contain a detailed description and schematic drawing of the equipment to be placed in Level 3's Collocation Space(s) and an estimate of the amount of square footage required.

6.1.2 Subsequent Application Fee. In the event Level 3 or Level 3's Guest(s) desire to modify the use of the Collocation Space, Level 3 shall complete an Application document detailing all information regarding the modification to the Collocation Space together with payment of the minimum Subsequent Application Fee as stated in Exhibit A. Said minimum Subsequent Application Fee shall be considered a partial payment of the applicable

Subsequent Application Fee which shall be calculated as set forth below. BellSouth shall determine what modifications, if any, to the Central Office premises are required to accommodate the change requested by Level 3 in the Application. Such necessary modifications to the Central Office premises may include but are not limited to, floor loading changes, changes necessary to meet HVAC requirements, changes to power plant requirements, and equipment additions. The fee paid by Level 3 for its request to modify the use of the Collocation Space shall be dependent upon the modification requested. Where the subsequent application does not require provisioning or construction work by BellSouth, no Subsequent Application Fee will be required and the pre-paid fee shall be refunded to Level 3. The fee for an application where the modification requested has limited effect (e.g., does not require capital expenditure by BellSouth) shall be the Subsequent Application Fee as set forth in Exhibit A. If the modification requires capital expenditure assessment, a fee ranging from the minimum Subsequent Application Fee up to the full Application Fee Charge for the appropriate state shall apply. In the event such modifications require the assessment of a full Application Fee as set forth in Exhibit A, the outstanding balance shall be due by Level 3 within 30 calendar days following Level 3's receipt of a bill or invoice from BellSouth.

6.2 Application Response. In addition to the notice of space availability pursuant to Section 2.1, BellSouth will respond within ten (10) business days of receipt of an Application whether the Application is Bona Fide, and if it is not Bona Fide, the items necessary to cause the Application to become Bona Fide. BellSouth will not classify an Application as not Bona Fide for de minimis or clerical errors which do not affect the ability of Application to be processed. When space has been determined to be available, BellSouth will provide a comprehensive written response within thirty (30) business days of receipt of a complete application. When multiple applications are submitted within a fifteen business day window, BellSouth will respond to the applications as soon as possible, but no later than the following: within thirty (30) business days for applications 1-5; within thirty-six (36) business days for applications 6-10; within forty-two (42) business days for applications 11-15. Response intervals for multiple applications submitted within the same timeframe for the same state in excess of 15 must be negotiated. All negotiations shall consider the total volume from all requests from telecommunications companies for collocation. The Application Response will detail whether the amount of space requested is available or if the amount of space requested is not available, the amount of space that is available. The response will also include the configuration of the space.

6.2.1 If BellSouth knows at the time of providing the Application Response that local building code does not allow the provisioning of the requested form of collocation (e.g. cageless and shared), BellSouth will notify Level 3 of such building code restrictions. If BellSouth determines after the Application Response that local building code does not allow the provisioning of the requested form of collocation, BellSouth will provide Level 3 written notice of such restriction.

6.3 Bona Fide Firm Order. Level 3 shall indicate its intent to proceed with equipment installation in a BellSouth Central Office by submitting a Bona Fide Firm Order to BellSouth. A Bona Fide Firm Order requires Level 3 to complete the Application/Inquiry process described in Subsection 6.1, preceding, and submit the Expanded Interconnection Bona Fide Firm Order document (BSTEI-1P-F) indicating acceptance of the written application response provided by BellSouth ("Bona Fide Firm Order") and all appropriate fees. The Bona Fide Firm Order must be received by BellSouth no later than thirty (30) calendar days after BellSouth's response to Level 3's Application/Inquiry. If Level 3 makes changes to its

application in light of BellSouth's written Application Response, BellSouth will be required to re-evaluate and respond to the change(s). In this event, BellSouth's provisioning interval will not start until the re-evaluation and response to the change(s) is complete and the Bona Fide Firm Order is received by BellSouth and all appropriate fees and duties have been executed. If BellSouth needs to reevaluate Level 3's application as a result of changes requested by Level 3 to Level 3's original application, then BellSouth will charge Level 3 a fee based upon the additional engineering hours required to do the reassessment. Major changes such as requesting additional space or adding additional equipment may require Level 3 to resubmit the application with an application fee.

6.3.1 BellSouth will establish a firm order date, per request, based upon the date BellSouth is in receipt of a Bona Fide Firm Order. BellSouth will acknowledge the receipt of Level 3's Bona Fide Firm Order within five (5) business days of receipt indicating that the Bona Fide Firm Order has been received. A BellSouth response to a Bona Fide Firm Order will include a Firm Order Confirmation containing the firm order date.

6.3.2 BellSouth will permit one accompanied site visit to Level 3's designated collocation arrangement location after receipt of the Bona Fide Firm Order without charge to Level 3.

6.3.3 Space preparation for the Collocation Space will not begin until BellSouth receives the Bona Fide Firm Order and all applicable fees.

6.3.4 Except for a site visit under 6.3.2., Level 3 must submit to BellSouth the completed Access Control Request Form (RF-2906-A) for all employees or agents requiring access to the BellSouth Central Office a minimum of 30 calendar days prior to the date Level 3 desires access to the Collocation Space.

6.4 Construction and Provisioning Interval. BellSouth will negotiate construction and provisioning intervals per request on an individual case basis. Excluding the time interval required to secure the appropriate government licenses and permits, BellSouth will use best efforts to complete construction for collocation arrangements under ordinary conditions as soon as possible and within a maximum of 90 business days from receipt of a complete and accurate Bona Fide Firm Order. Ordinary conditions are defined as space available with only minor changes to support systems required, such as but not limited to, HVAC, cabling and the power plant(s). Excluding the time interval required to secure the appropriate government licenses and permits, BellSouth will use best efforts to complete construction of all other collocation space ("extraordinary conditions") within 130 business days of the receipt of a complete and accurate Bona Fide Firm Order. Extraordinary conditions are defined to include but are not limited to major BellSouth equipment rearrangement or addition; power plant addition or upgrade; major mechanical addition or upgrade; major upgrade for ADA compliance; environmental hazard or hazardous materials abatement.

6.4.1 Joint Planning Meeting. Unless otherwise agreed to by the Parties, a joint planning meeting or other method of joint planning between BellSouth and Level 3 will commence within a maximum of 15 business days from BellSouth's receipt of a Bona Fide Firm Order and the payment of agreed upon fees. At such meeting, the Parties will agree to the preliminary design of the Collocation Space and the equipment configuration requirements as reflected in the Application and affirmed in the Bona Fide Firm Order. The Collocation

Space Completion time period will be provided to Level 3 during the joint planning meeting or as soon as possible thereafter. BellSouth will complete all design work following the joint planning meeting.

6.4.2 Permits. Each Party or its agents will diligently pursue filing for the permits required for the scope of work to be performed by that Party or its agents within 7 business days of the completion of finalized construction designs and specifications.

6.4.3 Acceptance Walk Through. Level 3 and BellSouth will complete an acceptance walk through of each Collocation Space requested from BellSouth by Level 3. BellSouth will correct any deviations to Level 3's original or jointly amended requirements within five (5) business days after the walk through, unless the Parties jointly agree upon a different time frame.

6.5 Use of Certified Vendor. Level 3 shall select a vendor which has been approved as a BellSouth Certified Vendor to perform all engineering and installation work required in the Collocation Space. In some cases, Level 3 must select separate BellSouth Certified Vendors for transmission equipment, switching equipment and power equipment. BellSouth shall provide Level 3 with a list of Certified Vendors upon request. The Certified Vendor(s) shall be responsible for installing Level 3's equipment and components, installing co-carrier cross connects, extending power cabling to the BellSouth power distribution frame, performing operational tests after installation is complete, and notifying BellSouth's equipment engineers and Level 3 upon successful completion of installation. The Certified Vendor shall bill Level 3 directly for all work performed for Level 3 pursuant to this Attachment and BellSouth shall have no liability for nor responsibility to pay such charges imposed by the Certified Vendor. BellSouth shall consider certifying Level 3 or any vendor proposed by Level 3.

6.6 Alarm and Monitoring. BellSouth shall place environmental alarms in the Central Office for the protection of BellSouth equipment and facilities. Level 3 shall be responsible for placement, monitoring and removal of environmental and equipment alarms used to service Level 3's Collocation Space. Upon request, BellSouth will provide Level 3 with applicable tariffed service(s) to facilitate remote monitoring of collocated equipment by Level 3. Both parties shall use best efforts to notify the other of any verified environmental hazard known to that party. The parties agree to utilize and adhere to the Environmental Hazard Guidelines identified as Exhibit B attached hereto.

6.7 Basic Telephone Service. Upon request of Level 3, BellSouth will provide basic telephone service to the Collocation Space under the rates, terms and conditions of the current tariff offering for the service requested.

6.8 Space Preparation. BellSouth shall pro rate the costs of any renovation or upgrade to Central Office space or support mechanisms which is required to accommodate physical collocation. Level 3's pro rated share will be calculated by multiplying such cost by a percentage equal to the amount of square footage occupied by Level 3 divided by the total Central Office square footage receiving renovation or upgrade. For this section, support mechanisms provided by BellSouth may include, but not be limited to heating/ventilation/air conditioning (HVAC) equipment, HVAC duct work, cable support structure, fire wall(s), mechanical upgrade, asbestos abatement, or ground plane addition. Such renovation or

upgrade will be evaluated and the charges assessed on a per Central Office basis. BellSouth will reimburse Level 3 in an amount equal to Level 3 reasonable, demonstrative and mitigated expenditures incurred as a direct result of delays to the completion and turnover dates caused by BellSouth.

6.9 Virtual Collocation Transition. BellSouth offers Virtual Collocation pursuant to the rates, terms and conditions set forth in its F.C.C. Tariff No. 1. For the interconnection to BellSouth's network and access to BellSouth unbundled network elements, Level 3 may purchase 2-wire and 4-wire Cross-Connects as set forth in Exhibit A, and Level 3 may place within its Virtual Collocation arrangements the telecommunications equipment set forth in Section 5.1. In the event physical collocation space was previously denied at a location due to technical reasons or space limitations, and that physical collocation space has subsequently become available, Level 3 may transition its virtual collocation arrangements to physical collocation arrangements and pay the appropriate non-recurring fees for physical collocation and for the rearrangement or reconfiguration of services terminated in the virtual collocation arrangement. In the event that BellSouth knows when additional space for physical collocation may become available at the location requested by Level 3, such information will be provided to Level 3 in BellSouth's written denial of physical collocation. To the extent that (i) physical collocation space becomes available to Level 3 within 180 days of BellSouth's written denial of Level 3's request for physical collocation, and (ii) Level 3 was not informed in the written denial that physical collocation space would become available within such 180 days, then Level 3 may transition its virtual collocation arrangement to a physical collocation arrangement and will receive a credit for any nonrecurring charges previously paid for such virtual collocation. Level 3 must arrange with a BellSouth certified vendor for the relocation of equipment from its virtual collocation space to its physical collocation space and will bear the cost of such relocation.

6.10 Cancellation. If, at anytime, Level 3 cancels its order for the Collocation Space(s), Level 3 will reimburse BellSouth for any reasonable expenses incurred up to the date that written notice of the cancellation is received. In no event will the level of reimbursement under this paragraph exceed the maximum amount Level 3 would have otherwise paid for work undertaken by BellSouth if no cancellation of the order had occurred.

6.11 Licenses. Level 3, at its own expense, will be solely responsible for obtaining from governmental authorities, and any other appropriate agency, entity, or person, all rights, privileges, and licenses necessary or required to operate as a provider of telecommunications services to the public or to occupy the Collocation Space.

7. RATES AND CHARGES

7.1 Non-recurring Fees. In addition to the Application Fee referenced in Section 6, preceding, Level 3 shall remit payment of a Cable Installation Fee and one-half (1/2) of the estimated Space Preparation Fee, as applicable, coincident with submission of a Bona Fide Firm Order. The outstanding balance of the actual Space Preparation Fee shall be due thirty (30) calendar days following Level 3's receipt of a bill or invoice from BellSouth. Once the installation of the initial equipment arrangement is complete, a subsequent application fee may apply (as described in Subsection 7.4), when Level 3 requests a modification to the arrangement.

7.2 Documentation. BellSouth shall provide documentation to establish the actual Space Preparation Fee. The Space Preparation Fee will be pro rated as prescribed in Section 6, preceding.

7.3 Space Preparation Fee in North Carolina. In North Carolina, the Space Preparation Fee is a monthly recurring charge, assessed per arrangement, per location, which is due beginning with the date on which BellSouth releases the Collocation Space for occupancy or on the date Level 3 first occupies the Collocation Space, which include survey, engineering, design and modification costs for network, building and support systems. In the event Level 3 opts for cageless space, the space preparation charge will be assessed based on the total floor space dedicated to Level 3 as described in Section 7.5. The Space Preparation Fee always consists of charges for Central Office Modifications, Power, and Common Systems Modifications. The charge for Common Systems Modification will be on a per square foot basis for cageless and on a per cage basis for caged collocation. The charge for Power will be assessed per the nominal –48V DC ampere requirements specified by Level 3 on the Bona Fide Application.

7.4 Space Preparation Fee in Florida. In Florida, the Space Preparation Fee is a monthly recurring charge, assessed per arrangement, per location, which is due beginning with the date on which BellSouth releases the Collocation Space for occupancy or on the date Level 3 first occupies the Collocation Space, which include survey, engineering, design and modification costs for network, building and support systems. In the event Level 3 opts for cageless space, the space preparation charge will be assessed based on the total floor space dedicated to Level 3 as described in Section 7.5. The Space Preparation Fee always consists of charges for Firm Order Processing, Central Office Modifications, Power, and Common Systems Modifications. The charge for Common Systems Modification will be on a per square foot basis for cageless and on a per cage basis for caged collocation. The charge for Power will be assessed per the nominal –48V DC ampere requirements specified by Level 3 on the Bona Fide Application.

7.5 Cable Installation. Cable Installation Fee(s) are assessed per entrance fiber placed.

7.6 Floor Space. The floor space charge includes reasonable charges for lighting, heat, air conditioning, ventilation and other allocated expenses associated with maintenance of the Central Office but does not include amperage necessary to power Level 3's equipment. When the Collocation Space is enclosed, Level 3 shall pay floor space charges based upon the number of square feet so enclosed. When the Collocation Space is not enclosed, Level 3 shall pay floor space charges based upon the following floor space calculation: [(depth of the equipment lineup in which the rack is placed) + (0.5 x maintenance aisle depth) + (0.5 x wiring aisle depth)] X (width of rack and spacers). For purposes of this calculation, the depth of the equipment lineup shall consider the footprint of equipment racks plus any equipment overhang. BellSouth will assign unenclosed Collocation Space in conventional equipment rack lineups where feasible. In the event Level 3's collocated equipment requires special cable racking, isolated grounding or other treatment which prevents placement within conventional equipment rack lineups, Level 3 shall be required to request an amount of floor space sufficient to accommodate the total equipment arrangement. Floor space charges are due

beginning with the date on which BellSouth releases the Collocation Space for occupancy or on the date Level 3 first occupies the Collocation Space, whichever is sooner.

7.7Power. BellSouth shall supply -48 Volt (-48V) DC power for Level 3's Collocation Space within the central office premises and shall make available AC power at Level 3's option for Adjacent Arrangement collocation.

7.7.1Charges for -48V DC power will be assessed per ampere per month based upon the certified vendor engineered and installed power feed fused ampere capacity. Rates include redundant feeder fuse positions (A&B) and cable rack to Level 3's equipment or space enclosure. When obtaining power from a BellSouth Battery Distribution Fuse Bay, fuses and power cables (A&B) must be engineered (sized), and installed by Level 3's certified vendor. When obtaining power from a BellSouth Power Board, power cables (A&B) must be engineered (sized), and installed by Level 3's certified power vendor. Level 3's certified vendor must also provide a copy of the engineering power specification prior to the Commencement Date. In the event BellSouth shall be required to construct additional DC power plant or upgrade the existing DC power plant in a Central Office as a result of Level 3's request to collocate in that Central Office ("Power Plant Construction"), Level 3 shall pay its pro-rata share of costs associated with the Power Plant Construction. The determination of whether Power Plant Construction is necessary shall be within BellSouth's sole, but reasonable, discretion. BellSouth shall comply with all BellCore (Telcordia) and ANSI Standards regarding power cabling, including BellCore (Telcordia) Network Equipment Building System (NEBS) Standard GR-63-CORE. BellSouth will notify Level 3 of the need for the Power Plant Construction and will estimate the costs associated with the Power Plant Construction if BellSouth were to perform the Power Plant Construction. The costs of power plant construction shall be pro-rated and shared among all who benefit from that construction. Level 3 shall pay BellSouth one-half of its prorata share of the estimated Power Plant Construction costs prior to commencement of the work. Level 3 shall pay BellSouth the balance due (actual cost less one-half of the estimated cost) within thirty (30) days of completion of the Power Plant Construction. Level 3 has the option to perform the Power Plant Construction itself; provided, however, that such work shall be performed by a BellSouth certified contractor and such contractor shall comply with BellSouth's guidelines and specifications. Where the Power Plant Construction results in construction of a new power plant room, upon termination of this Attachment Level 3 shall have the right to remove its equipment from the power plant room, but shall otherwise leave the room intact. Where the Power Plant Construction results in an upgrade to BellSouth's existing power plant, upon termination of this Attachment, such upgrades shall become the property of BellSouth.

7.7.2 Charges for AC power will be assessed per breaker ampere per month based upon the certified vendor engineered and installed power feed fused ampere capacity. Rates include the provision of commercial and standby AC power. When obtaining power from a BellSouth Service Panel, fuses and power cables must be engineered (sized), and installed by Level 3's certified vendor. Level 3's certified vendor must also provide a copy of the engineering power specification prior to the Commencement Date. Charges for AC power shall be assessed pursuant to the rates specified in Exhibit A. AC power voltage and phase ratings shall be determined on a per location basis.

7.8 Security Escort. A security escort will be required whenever Level 3 or its approved agent desires access to the entrance manhole or must have access to the Central Office Premises after the one accompanied site visit allowed pursuant to subsection 6.2.2 prior to completing BellSouth's Security Training requirements and/or prior to Space Acceptance. Rates for a security escort, if applicable, are assessed in one-half (1/2) hour increments according to the schedule appended hereto as Exhibit A.

7.9 Rate "True-Up." The Parties agree that the prices reflected as interim herein shall be "trued-up" (up or down) based on final prices either determined by further agreement or by final order, including any appeals, in a proceeding involving BellSouth before the regulatory authority for the state in which the services are being performed or any other body having jurisdiction over this agreement (hereinafter "Commission"). Under the "true-up" process, the interim price for each service shall be multiplied by the volume of that service purchased to arrive at the total interim amount paid for that service ("Total Interim Price"). The final price for that service shall be multiplied by the volume purchased to arrive at the total final amount due ("Total Final Price"). The Total Interim Price shall be compared with the Total Final Price. If the Total Final Price is more than the Total Interim Price, Level 3 shall pay the difference to BellSouth. If the Total Final Price is less than the Total Interim Price, BellSouth shall pay the difference to Level 3. Each party shall keep its own records upon which a "true-up" can be based and any final payment from one party to the other shall be in an amount agreed upon by the Parties based on such records. In the event of any disagreement as between the records or the Parties regarding the amount of such "true-up," the Parties agree that the Commission shall be called upon to resolve such differences.

7.10 Other. If no rate is identified in the contract, the rate for the specific service or function will be negotiated by the parties upon request by either party. Payment of all other charges under this Attachment shall be due thirty (30) days after receipt of the bill (payment due date). Level 3 will pay a late payment charge of one and one-half percent (1-1/2%) assessed monthly on any balance which remains unpaid after the payment due date.

8. INSURANCE

8.1 Level 3 shall, at its sole cost and expense, procure, maintain, and keep in force insurance as specified in this Article VI and underwritten by insurance companies licensed to do business in the states applicable under this Attachment and having a BEST Insurance Rating of B ++ X (B ++ ten).

8.2 Level 3 shall maintain the following specific coverage:

8.2.1 Commercial General Liability coverage in the amount of ten million dollars (\$10,000,000.00) or a combination of Commercial General Liability and Excess/Umbrella coverage totaling not less than ten million dollars (\$10,000,000.00). BellSouth shall be named as an ADDITIONAL INSURED on ALL Level 3 applicable policies as specified herein.

8.2.2 Statutory Workers Compensation coverage and Employers Liability coverage in the amount of one hundred thousand dollars (\$100,000.00) each accident, one

hundred thousand dollars (\$100,000.00) each employee by disease, and five hundred thousand dollars (\$500,000.00) policy limit by disease.

8.3 The limits set forth in Subsection 6.2 above may be increased by BellSouth from time to time during the term of this Attachment upon thirty (30) days notice to Level 3 to at least such minimum limits as shall then be customary with respect to comparable occupancy of BellSouth structures.

8.4 All policies purchased by Level 3 shall be deemed to be primary and not contributing to or in excess of any similar coverage purchased by BellSouth. All insurance must be in effect on or before the date equipment is delivered to BellSouth's Central Office and shall remain in effect for the term of this Attachment or until all Level 3's property has been removed from BellSouth's Central Office, whichever period is longer. If Level 3 fails to maintain required coverage, BellSouth may pay the premiums thereon and seek reimbursement of same from Level 3.

8.5 Level 3 shall submit certificates of insurance reflecting the coverage required pursuant to this Section a minimum of ten (10) days prior to the commencement of any work in the Collocation Space. Failure to meet this interval may result in construction and equipment installation delays. Level 3 shall arrange for BellSouth to receive thirty (30) days advance notice of cancellation from Level 3's insurance company. Level 3 shall forward a certificate of insurance and notice of cancellation to BellSouth at the following address:

BellSouth Telecommunications, Inc.
Attn.: Risk Management Coordinator
600 N. 19th Street, 18B3
Birmingham, Alabama 35203

8.6 Level 3 must conform to recommendations made by BellSouth's fire insurance company to the extent BellSouth has agreed to, or shall hereafter agree to, such recommendations.

8.7 BellSouth shall procure and maintain insurance coverage, or will maintain a program of self insurance, at equivalent or higher levels as those imposed upon Level 3 under this section.

8.8 Failure to comply with the provisions of this Section will be deemed a material breach of this Attachment.

9. MECHANICS LIENS

9.1 If any mechanics lien or other liens shall be filed against property of either party (BellSouth or Level 3), or any improvement thereon by reason of or arising out of any labor or materials furnished or alleged to have been furnished or to be furnished to or for the other party or by reason of any changes, or additions to said property made at the request or under the direction of the other party, the other party directing or requesting those changes shall, within thirty (30) days after receipt of written notice from the party against whose property said

lien has been filed, either pay such lien or cause the same to be bonded off the affected property in the manner provided by law. The party causing said lien to be placed against the property of the other shall also defend, at its sole cost and expense, on behalf of the other, any action, suit or proceeding which may be brought for the enforcement of such liens and shall pay any damage and discharge any judgment entered thereon.

10. INSPECTIONS

10.1 BellSouth may conduct an inspection of Level 3's equipment and facilities in the Collocation Space(s) prior to the activation of facilities between Level 3's equipment and equipment of BellSouth or if Level 3 later adds equipment, and may otherwise conduct routine inspections at reasonable intervals mutually agreed upon by the Parties. BellSouth shall provide Level 3 with a minimum of forty-eight (48) hours or two (2) business days, whichever is greater, advance notice of all such inspections. All costs of such inspection shall be borne by BellSouth.

11. SECURITY AND SAFETY REQUIREMENTS

11.1 The security and safety requirements set forth in this section are as stringent as the security requirements BellSouth maintains at its own premises either for their own employees or for authorized contractors. Only BellSouth employees, BellSouth certified vendors and authorized employees, authorized Guests, pursuant to Section 3.3, preceding, or authorized agents of Level 3 will be permitted in the BellSouth Central Office. Level 3 shall provide its employees and agents with picture identification which must be worn and visible at all times while in the Collocation Space or other areas in or around the Central Office. The photo identification card shall bear, at a minimum, the employee's name and photo, and the Level 3 name. BellSouth reserves the right to remove from its premises any employee of Level 3 not possessing identification issued by Level 3. Level 3 shall hold BellSouth harmless for any damages resulting from such removal of its personnel from BellSouth premises. Level 3 shall be solely responsible for ensuring that any Guest of Level 3 is in compliance with all subsections of this Section 11.

11.1.1 Level 3 will be required, at its own expense, to conduct a statewide investigation of criminal history records for each Level 3 employee being considered for work on the BellSouth Central Office, for the states/counties where the Level 3 employee has worked and lived for the past five years. Where state law does not permit statewide collection or reporting, an investigation of the applicable counties is acceptable.

11.1.2 Level 3 will be required to administer to their personnel assigned to the BellSouth Central Office security training either provided by BellSouth, or meeting criteria defined by BellSouth.

11.1.3 Level 3 shall not assign to the BellSouth Central Office any personnel with records of felony criminal convictions. Level 3 shall not assign to the BellSouth Central Office any personnel with records of misdemeanor convictions, without advising BellSouth of the nature and gravity of the offense(s). BellSouth reserves the right to refuse building access to any Level 3 personnel who have been identified to have misdemeanor criminal convictions.

11.1.4 For each Level 3 employee requiring access to a BellSouth Central Office pursuant to this agreement, Level 3 shall furnish BellSouth, prior to an employee gaining such access, certification that the aforementioned background check and security training were completed. The certification will contain a statement that no felony convictions were found and certifying that the security training was completed by the employee. If the employee's criminal history includes misdemeanor convictions, Level 3 will disclose the nature of the convictions to BellSouth at that time.

11.1.5 At BellSouth's request, Level 3 shall promptly remove from the BellSouth's premises any employee of Level 3 BellSouth does not wish to grant access to its premises pursuant to any investigation conducted by BellSouth.

11.2 Notification to BellSouth. BST reserves the right to interview Level 3's employees, agents, or contractors. Level 3 and its contractors shall cooperate fully with BellSouth's investigation into allegations of wrongdoing or criminal conduct committed by or involving Level 3's employees, agents, or contractors. Additionally, BellSouth reserves the right to bill Level 3 for all costs associated with investigations involving its employees, agents, or contractors if it can be reasonably established that Level 3's employees, agents, or contractors are responsible for the alleged act. BellSouth shall bill Level 3 for BellSouth property which is stolen or damaged where an investigation determines the culpability of Level 3's employees, agents, or contractors. Level 3 shall notify BellSouth in writing immediately in the event that the CLEC discovers one of its employees already working on the BellSouth premises is a possible security risk. BellSouth reserves the right to permanently remove from its premises any employee of Level 3 identified as posing a security risk to BellSouth or any other CLEC, or having violated BellSouth policies set forth in the BellSouth CLEC Security Training. Level 3 shall hold BellSouth harmless for any damages resulting from such removal of its personnel from BellSouth premises.

11.3 Use of Supplies. Unauthorized use of telecommunications equipment or supplies by either Party whether or not used routinely to provide telephone service (e.g. plug-in cards,) will be strictly prohibited and handled appropriately. Costs associated with such unauthorized use may be charged to the offending party as may be all associated investigative costs. Upon request, either Party shall promptly and permanently remove from BellSouth's Central Office any employee repeatedly found to be in violation of this rule.

11.4 Use of Official Lines Except for non-toll calls necessary in the performance of their work, employees shall not use the telephones of the other Party in the BellSouth Central Office. Charges for unauthorized telephone calls may be charged to the offending party as may be all associated investigative costs. Upon request, either Party shall promptly and permanently remove from BellSouth's premises any employee repeatedly found to be in violation of this rule.

11.5 Accountability. Full compliance with the Security requirements of this section shall in no way limit the accountability of any CLEC for the improper actions of its employees.

12. DESTRUCTION OF COLLOCATION SPACE

12.1 In the event a Collocation Space is wholly or partially damaged by fire, windstorm, tornado, flood or by similar causes to such an extent as to be rendered wholly unsuitable for Level 3's permitted use hereunder, then either party may elect within ten (10) days after such damage, to terminate this Attachment, and if either party shall so elect, by giving the other written notice of termination, both parties shall stand released of and from further liability under the terms hereof. If the Collocation Space shall suffer only minor damage and shall not be rendered wholly unsuitable for Level 3's permitted use, or is damaged and the option to terminate is not exercised by either party, BellSouth covenants and agrees to proceed promptly without expense to Level 3, except for improvements not the property of BellSouth, to repair the damage. BellSouth shall have a reasonable time within which to rebuild or make any repairs, and such rebuilding and repairing shall be subject to delays caused by storms, shortages of labor and materials, government regulations, strikes, walkouts, and causes beyond the control of BellSouth, which causes shall not be construed as limiting factors, but as exemplary only. Level 3 may, at its own expense, accelerate the rebuild of its collocated space and equipment provided however that a certified vendor is used and the necessary space preparation has been completed. Rebuild of equipment must be performed by a BellSouth Certified Vendor. If Level 3's acceleration of the project increases the cost of the project, then those additional charges will be incurred by Level 3. Where allowed and where practical, Level 3 may erect a temporary facility while BellSouth rebuilds or makes repairs. In all cases where the Collocation Space shall be rebuilt or repaired, Level 3 shall be entitled to an equitable abatement of rent and other charges, depending upon the unsuitability of the Collocation Space for Level 3's permitted use, until such Collocation Space is fully repaired and restored and Level 3's equipment installed therein (but in no event later than thirty (30) days after the Collocation Space is fully repaired and restored). Where Level 3 has placed an Adjacent Arrangement pursuant to section 3.4, Level 3 shall have the sole responsibility to repair or replace said Adjacent Arrangement provided herein. Pursuant to this section, BellSouth will restore the associated services to the Adjacent Arrangement.

13. EMINENT DOMAIN

13.1 If the whole of a Collocation Space or Adjacent Arrangement shall be taken by any public authority under the power of eminent domain, then, with respect to such Collocation Space or Adjacent Arrangement this Attachment shall terminate as of the day possession shall be taken by such public authority and rent and other charges for the Collocation Space or Adjacent Arrangement shall be paid up to that day with proportionate refund by BellSouth of such rent and charges as may have been paid in advance for a period subsequent to the date of the taking. If any part of the Collocation Space or Adjacent Arrangement shall be taken under eminent domain, BellSouth and Level 3 shall each have the right to terminate this Attachment with respect to such Collocation Space or Adjacent Arrangement and declare the same null and void, by written notice of such intention to the other party within ten (10) days after such taking.

14. NONEXCLUSIVITY

12.1 Level 3 understands that this Attachment is not exclusive and that BellSouth may enter into similar agreements with other parties. Assignment of space pursuant to all such

agreements shall be determined by space availability and made on a first come, first served basis.

14.1

EXHIBIT A: BELLSOUTH/CLEC-1 RATES – ALABAMA
PHYSICAL COLLOCATION

Rates marked with an asterisk (*) are interim and are subject to true-up

USOC	Rate Element Description	Unit	Recurring Rate (RC)	Non-Recurring Rate (NRC)
PE1BA	Application Fee	Per request	NA	\$7,124.00 Disconnect Charge \$1.73
PE1CA	Subsequent Application Fee (Note 1)	Per request	NA	\$1,600.00 Minimum
PE1BB	Space Preparation Fee (Note 2) Mechanical / HVAC*	Per ton (one ton minimum)		\$2,400.00
PE1SB	Ground Bar*	Per connection		\$720.00
PE1SC	Project Management*	Per arrangement		\$1,675.00
PE1SD	Cable Racking / Fiber Duct	Per arrangement, sq. ft.		ICB
PE1SE	Frame / Aisle Lighting	Per arrangement, sq. ft.		ICB
PE1SG	Framework Ground Conductors	Per arrangement		ICB
PE1SH	Extraordinary Modifications	Per arrangement		ICB
PE1BW	Space Enclosure (Note 3) Welded Wire-mesh	Per first 100 sq. ft.	\$136.64	NA
PE1CW	Welded Wire-mesh	Per add'l 50 sq. ft.	\$15.85	NA
PE1PJ	Floor Space	Per sq. ft.	\$3.85	NA
PE1BD	Cable Installation	Per cable	NA	\$2,335.00
PE1PM	Cable Support Structure	Per entrance cable	\$23.23	NA
PE1PL	Power -48V DC Power	Per amp	\$7.14	ICB
PE1FB	120V AC Power single phase*	Per breaker amp	\$5.50	ICB
PE1FD	240V AC Power single phase*	Per breaker amp	\$11.00	ICB
PE1FE	120V AC Power three phase*	Per breaker amp	\$16.50	ICB
PE1FG	277 AC Power three phase*	Per breaker amp	\$38.20	ICB
PE1P2	Cross Connects (Note 4) 2-wire	Per cross connect	\$0.28	First/Add'l \$30.76/\$29.40
PE1P4	4-wire		\$0.56	\$31.01/\$29.58
PE1P1	DS-1		\$2.14	\$60.81/\$41.71
PE1P3	DS-3		\$38.63	\$57.80/\$39.81

ALABAMA (continued)				
USOC	Rate Element Description	Unit	Recurring Rate (RC)	Non-Recurring Rate (NRC)
PE1F2 PE1F4	Cross Connects (continued) 2-fiber 4-fiber 2-wire 4-wire DS-1 DS-3 2-fiber 4-fiber	Per cross connect	\$12.10 \$21.75	First/Add'l \$55.46/\$39.18 \$66.71/\$50.43 Disconnect Charges First/Add'l \$12.75/\$11.38 \$12.82/\$11.39 \$12.85/\$11.50 \$14.93/\$11.76 \$16.83/\$13.27 \$21.86/\$18.31
PE1ES Fiber PE1DS Copper (TBD)	Co-Carrier Cross-Connect (Note 5) Fiber Cable Support Structure, existing Copper or Coaxial Cable Support Structure, existing Cable Support Structure Construction, new	Per linear ft. Per linear ft. Per new construction	\$0.06 \$0.03 NA	NA NA ICB
PE1AX PE1AA PE1AR	Security Access System Security System* New Access Card Activation* Administrative change, existing card* Replace lost or stolen card*	Per central office Per card Per card Per card	\$52.00	\$55.00 \$35.00 \$250.00
PE1SR	Space Availability Report*	Per premises requested		\$550.00
PE1PE PE1PF PE1PG PE1PH PE1B2 PE1B4	POT Bay Arrangements <i>Prior to 6/1/99</i> 2-Wire Cross-Connect 4-Wire Cross-Connect DS1 Cross-Connect DS3 Cross-Connect 2-Fiber Cross-Connect 4-Fiber Cross-Connect	Per cross connect	\$0.08 \$0.17 \$0.69 \$4.74 \$32.02 \$40.48	NA NA NA NA NA NA

ALABAMA (continued)				
USOC	Rate Element Description	Unit	Recurring Rate (RC)	Non-Recurring Rate (NRC)
AEH	Additional Engineering Fee (Note 6)	Per request, First half hour/add'l half hour		First/Add'l Basic Time \$31.00/\$22.00 Overtime \$37.00/\$26.00
	Security Escort	Per half hr/add'l half hr		
PE1BT	Basic Time		NA	\$43.47/\$25.82
PE1OT	Overtime		NA	\$55.25/\$32.79
PE1PT	Premium Time		NA	\$67.03/\$39.76

Note(s):

N/A refers to rate elements which do not have a negotiated rate.

- (1) **Subsequent Application Fee:** BellSouth requires the submission of an Application Fee for modifications to an existing arrangement. However, when the modifications do not require BellSouth assessment related to expenditure of capital, BellSouth will assess the Subsequent Application Fee in lieu of the Application Fee. Proposed modifications that could result in assessment of a Subsequent Application Fee would cause BellSouth to analyze the following but are not limited to: floor loading changes, changes to HVAC requirements, power requirement changes which may result in a power plant upgrade, environmental or safety requirements, or equipment relocation. Should the Subsequent Application Fee not be included as part of this Attachment, CLEC-1 will be assessed the full Application Fee for all subsequent activity for completed arrangements.
- (2) **Space Preparation Fee:** The Space Preparation Fee is a one-time fee, assessed per arrangement, per location. It recovers the costs associated with the shared physical collocation area within a Premises, which include survey, engineering, design and modification costs for network, building and support systems. In the event CLEC-1 opts for non-enclosed space, the space preparation fee will be assessed based on the total floor space dedicated to CLEC-1 as prescribed in Section 7 of the Collocation Attachment.
- (3) **Space Enclosure:** The Space Enclosure Construction Fee is a monthly recurring fee, assessed per enclosure, per location with a one-hundred (100) square foot minimum enclosure. It recovers costs associated with providing an optional equipment arrangement enclosure, which include architectural and engineering fees, materials, and installation costs. The cost for additional square feet is applicable only when ordered with the first 100 square feet and must be requested in fifty (50) square foot increments. CLEC-1 may, at its option, arrange with a BellSouth Certified Contractor to construct the space enclosure in accordance with BellSouth's guidelines and specifications. In this event, the BellSouth Certified Contractor shall directly bill CLEC-1 for the space enclosure, and this fee shall not be applicable.

EXHIBIT A: BELLSOUTH/CLEC-1 RATES – ALABAMA
PHYSICAL COLLOCATION (continued)

- (4) **Cross Connects:** The charges for cross connects are for orders placed electronically. Cross connect elements may also be ordered manually for which there is an additional charge per element.

	First / Additional	Disconnect Charges First / Additional
2-wire	\$34.03 / \$32.67	\$14.48 / \$13.11
4-wire	\$34.28 / \$32.85	\$14.55 / \$13.12
DS-1	\$64.08 / \$44.98	\$14.58 / \$13.23
DS-3	\$61.07 / \$43.08	\$16.66 / \$13.49

- (5) **Co-Carrier Cross-Connect:** As stated in Section 1.2 of the Collocation Attachment, CLEC-1 may connect to other CLECs within the designated Premises in addition to, and not in lieu of, interconnection to BellSouth services and facilities. Where BellSouth must construct a cable rack structure to house the Co-Carrier cross connection, construction charges will be applied on an individual case basis as described in Section 5.6.1 of the Collocation Attachment. BellSouth shall provide an estimate of these charges in the Application Response. Where an existing cable rack structure is in place and has sufficient capacity to accommodate the Co-Carrier cross connection requested, the recurring charges as stated in this Exhibit A shall apply.
- (6) **Additional Engineering Fee:** BellSouth’s additional engineering, and other labor costs associated with handling CLEC-1-requested modifications to requests in progress or augmentations to existing arrangements shall be recovered as Additional Engineering charges, under provisions in BellSouth’s F.C.C. Number 1 Tariff, Sections 13.1 and 13.2. Should Additional Engineering rates not be included, CLEC-1 agrees not to make changes to collocation arrangement after a Bona Fide Firm Order is submitted.

EXHIBIT A: BELLSOUTH/CLEC-1 RATES – FLORIDA
PHYSICAL COLLOCATION

Rates marked with an asterisk (*) are interim and are subject to true-up

USOC	Rate Element Description	Unit	Recurring Rate (RC)	Non-Recurring Rate (NRC)
PE1BA	Application Fee	Per request	\$15.53	\$3,248.00
PE1CA	Subsequent Application Fee (Note 1)	Per request	NA	\$1,600.00 Minimum
	Space Preparation Fee			
	Firm Order Processing*		NA	\$1,211.00
	Central Office Modification*	Per sq. ft.	\$2.58	NA
	Common Systems Modification – Cageless*	Per sq. ft.	\$2.96	NA
	Common Systems Modification – Caged*	Per cage	\$100.66	NA
	Space Enclosure (Note 2)			
PE1BW	Wire Cage	Per first 100 sq. ft.	\$41.99	NA
PE1BC	Gypsum Board Cage	Per first 100 sq. ft.	\$84.10	NA
PE1BF	Fire Rated Cage	Per first 100 sq. ft.	\$99.73	NA
PE1CW	Wire Cage	Per add'l 50 sq. ft.	\$4.14	NA
PE1CC	Gypsum Board Cage	Per add'l 50 sq. ft.	\$9.35	NA
PE1CF	Fire Rated Cage	Per add'l 50 sq. ft.	\$11.30	NA
PE1PJ	Floor Space	Per sq. ft.	\$4.25	NA
PE1BD	Cable Installation	Per cable	\$2.77	\$1,056.00
PE1PM	Cable Support Structure		\$22.94	NA
	Power			
PE1PL	-48V DC Power	Per amp	\$6.95	ICB
PE1FB	120V AC Power single phase*	Per breaker amp	\$5.50	ICB
PE1FD	240V AC Power single phase*	Per breaker amp	\$11.00	ICB
PE1FE	120V AC Power three phase*	Per breaker amp	\$16.50	ICB
PE1FG	277 AC Power three phase*	Per breaker amp	\$38.20	ICB
	Cross Connects (Note 3)			
PE1P2	2-wire	Per cross connect	\$0.0524	\$11.57
PE1P4	4-wire		\$0.0524	\$11.57

FLORIDA (continued)				
USOC	Rate Element Description	Unit	Recurring Rate (RC)	Non-Recurring Rate (NRC)
	Cross Connects (continued)	Per cross connect		
PE11S	DS-1/DCS		\$8.085	\$69.64
PE1P1	DS-1/DSX		\$4.110	\$69.64
PE13S	DS-3/DCS		\$56.97	\$528.00
PE13X	DS-3/DSX		\$10.06	\$528.00
PE1F2	Optical Cross Connects		\$6.46	\$2,431.00
PE1ES	Co-Carrier Cross-Connect Fiber Cable Support Structure*	Per linear ft., per cable	\$0.003	\$540.00
PE1DS	Copper or Coaxial Cable Support Structure*	Per linear ft., per cable	\$0.004	\$540.00
PE1AX	Security Access System Security System*	Per premises	\$89.48	
	New Access Card Activation*	Per card	\$0.06	\$56.03
PE1AA	Administrative change, existing card*	Per card		\$15.71
PE1AR	Replace lost or stolen card*	Per card		\$45.93
PE1SR	Space Availability Report*	Per premises requested		\$550.00
	POT Bay (Note 4)		NA	NA
AEH	Additional Engineering Fee (Note 5)	Per request, First half hour/add'l half hour		First/Add'l Basic Time \$31.00/\$22.00 Overtime \$37.00/\$26.00
PE1BT	Security Escort Basic Time	Per ¼ hour	NA	\$10.89
PE1OT	Overtime		NA	\$13.64
PE1PT	Premium Time		NA	\$16.40

EXHIBIT A: BELLSOUTH/CLEC-1 RATES – FLORIDA
PHYSICAL COLLOCATION (continued)

Note(s):

N/A refers to rate elements which do not have a negotiated rate.

- (1) **Subsequent Application Fee:** BellSouth requires the submission of an Application Fee for modifications to an existing arrangement. However, when the modifications do not require BellSouth to expend capital, BellSouth will assess the Subsequent Application Fee in lieu of the Application Fee. Proposed modifications that could result in assessment of a Subsequent Application Fee would cause BellSouth to analyze the following but are not limited to: floor loading changes, changes to HVAC requirements, power requirement changes which may result in a power plant upgrade, environmental or safety requirements, or equipment relocation. Should the Subsequent Application Fee not be included as part of this Attachment, CLEC-1 will be assessed the full Application Fee for all subsequent activity for completed arrangements.
- (2) **Space Enclosure Fee:** The Space Enclosure Construction Fee is a monthly recurring fee, assessed per enclosure, per location with a one-hundred (100) square foot minimum enclosure. It recovers costs associated with providing an optional equipment arrangement enclosure, which include architectural and engineering fees, materials, and installation costs. The cost for additional square feet is applicable only when ordered with the first 100 square feet and must be requested in fifty (50) square foot increments. CLEC-1 may, at its option, arrange with a BellSouth Certified Contractor to construct the space enclosure in accordance with BellSouth's guidelines and specifications. In this event, the BellSouth Certified Contractor shall directly bill CLEC-1 for the space enclosure, and this fee shall not be applicable.
- (3) **Cross Connects:** Rates shown are the equivalent per cross connect rates based on the Florida PSC Ordered rates as follows:

<u>Cross Connects</u>	<u>Per Cross Connect</u>	<u>RC</u>	<u>NRC</u>
2-wire	Per 100 X-Connects	\$5.24	\$1,157.00
4-wire	Per 100 X-Connects	\$5.24	\$1,157.00
DS-1/DCS	Per 28 X-Connects	\$226.39	\$1,950.00
DS-1/DSX	Per 28 X-Connects	\$11.51	\$1,950.00
DS-3/DCS	Per Cross Connect	\$56.97	\$ 528.00
DS-3/DSX	Per Cross Connect	\$10.06	\$528.00
Optical Cross Connects	Per Cross Connect	\$6.46	\$2,431.00

EXHIBIT A: BELLSOUTH/CLEC-1 RATES – FLORIDA
PHYSICAL COLLOCATION (continued)

- (4) **POT Bays:** BellSouth's Florida specific rates were established in the Florida Public Service Commission Docket No. 960833. The Commission did not set permanent rates for POT Bays, given the assumption by the Parties to the Proceeding that they will always provide their own POT Bays. It will be necessary for CLEC-1 to provide its own POT Bays per BellSouth specifications and provide the necessary information from which BellSouth can inventory.
- (5) **Additional Engineering Fee:** BellSouth's additional engineering, and other labor costs associated with handling CLEC-1-requested modifications to requests in progress or augmentations to existing arrangements shall be recovered as Additional Engineering charges, under provisions in BellSouth's F.C.C. Number 1 Tariff, Sections 13.1 and 13.2. Should Additional Engineering rates not be included, CLEC-1 agrees not to make changes to collocation arrangement after a Bona Fide Firm Order is submitted.

EXHIBIT A: BELLSOUTH/LEVEL 3 RATES - GEORGIA
PHYSICAL COLLOCATION

Rates marked with an asterisk (*) are interim and subject to true-up

USOC	Rate Element Description	Unit	Recurring Rate (RC)	Non-Recurring Rate (NRC)
PE1BA	Application Fee	Per Request	NA	\$3,850.00
PE1CA	Subsequent Application Fee (Note 1)	Per Request	NA	\$1600.00 Minimum
PE1BB	Space Preparation Fee (Note 2)	Per square foot	NA	\$100.00
PE1BW	Space Enclosure (Note 3) <i>Cages Prior to 6/1/99</i> Welded Wire-mesh	Per first 100 sq. ft.	\$170.64	NA
PE1CW	Welded Wire-mesh	Per add'l 50 sq. ft.	\$17.33	NA
PE1PJ	Floor Space Zone A	Per square foot	\$7.50	NA
PE1PK	Zone B	Per square foot	\$6.75	NA
PE1BD	Cable Installation	Per Cable	NA	\$2,750.00
PE1PM	Cable Support Structure	Per entrance cable	\$13.35	NA
PE1PL	Power			
	-48V DC Power	Per amp	\$7.14	ICB
	120V AC Power single phase*	Per breaker amp	\$5.50	ICB
	240V AC Power single phase*	Per breaker amp	\$11.00	ICB
	120V AC Power three phase*	Per breaker amp	\$16.50	ICB
	277V AC Power three phase*	Per breaker amp	\$38.20	ICB
PE1P2	Cross Connects 2-wire	Per Cross Connect	\$0.30	First / Additional \$12.60 / \$12.60
PE1P4	4-wire		\$0.50	\$12.60 / \$12.60
PE1P1	DS-1		\$8.00	\$155.00 / \$27.00
PE1P3	DS-3		\$72.00	\$155.00 / \$27.00
PE1F2	2-fiber		\$15.64	\$41.56 / \$29.82
PE1F4	4-fiber		\$28.11	\$50.53 / \$38.78

EXHIBIT A: BELLSOUTH/LEVEL 3 RATES - GEORGIA
PHYSICAL COLLOCATION (cont.)

USOC	Rate Element Description	Unit	Recurring Rate (RC)	Non-Recurring Rate (NRC)
PE1ES	Co-Carrier Cross-Connect (Note 4) Fiber Cable Support Structure, existing	Per linear foot	\$0.06	NA
PE1DS	Copper or Coaxial Cable Support Structure, existing	Per linear foot	\$0.03	NA
(TBD)	Cable Support Structure Construction, new	Per new construction	NA	ICB
PE1A1	Security Access System Security system* New Access Card Activation* Administrative change, existing card* Replace lost or stolen card*	Per Premises Per Card Per Card Per Card	\$52.00	\$55.00 \$35.00 \$250.00
	Space Availability Report*	Per Premises Requested		\$550.00
PE1PE	POT Bay Arrangements <i>Prior to 6/1/99</i> 2 Wire Cross-Connect	Per Cross Connect	\$0.40	NA
PE1PF	4 Wire Cross-Connect		\$1.20	NA
PE1PG	DS1 Cross-Connect		\$1.20	NA
PE1PH	DS3 Cross-Connect		\$8.00	NA
PE1B2	2 Fiber Cross-Connect		\$38.79	NA
PE1B4	4 Fiber Cross-Connect		\$52.31	NA
AEH	Additional Engineering Fee (Note 5)	Per request, First half hour/Add'l Half hour		First /Add'l Basic Time - \$31.00/\$22.00 Overtime - \$37.00/\$26.00
PE1BT	Security Escort Basic Time	Per 1/2	NA	\$41.00/\$25.00
PE1OT	Overtime	hour/Additional	NA	\$48.00/\$30.00

PE1PT	Premium Time	Half-hour	NA	\$55.00/\$35.00

EXHIBIT A: BELL SOUTH/LEVEL 3 RATES - GEORGIA
PHYSICAL COLLOCATION (cont.)

Note(s)

N/A refers to rate elements which do not have a negotiated rate.

- (1) **Subsequent Application Fee:** BellSouth requires the submission of an Application Fee for modifications to an existing arrangement. However, when the modifications do not require BellSouth to expend capital, BellSouth will assess the Subsequent Application Fee in lieu of the Application Fee. If the modification requires capital expenditure assessment, a fee ranging from the minimum Subsequent Application Fee up to the full Application Fee Charge for the appropriate state shall apply. Proposed modifications that could result in assessment of a Subsequent Application Fee would cause BellSouth to analyze the following but are not limited to: floor loading changes, changes to HVAC requirements, power requirement changes which may result in a power plant upgrade, environmental or safety requirements, or equipment relocation. Should the Subsequent Application Fee not be included as part of this Attachment, Level 3 will be assessed the full Application Fee for all subsequent activity for completed arrangements.
- (2) **Space Preparation Fee:** The Space Preparation Fee is a one-time fee, assessed per arrangement, per location. It recovers a portion of costs associated with the shared physical collocation area within a Premises, which include survey, engineering, design and modification costs for network, building and support systems. This is a set fee of \$100 per square foot as established by the Georgia Public Service Commission Order in Docket No. 7061-U. In the event Level 3 opts for non-enclosed space, the space preparation fee will be assessed based on the total floor space dedicated to Level 3 as prescribed in Section 7 of the Collocation Attachment.
- (3) **Space Enclosure Fee:** For cages requested prior to June 1, 1999, the Space Enclosure Construction Fee is a one-time fee, assessed per enclosure, per location with a one-hundred (100) square foot minimum enclosure. It recovers costs associated with providing an optional equipment arrangement enclosure, which include architectural and engineering fees, materials, and installation costs. The cost for additional square feet is applicable only when ordered with the first 100 square feet and must be requested in fifty (50) square foot increments. Level 3 may, at its option, arrange with a BellSouth certified contractor to construct the space enclosure in accordance with BellSouth's guidelines and specifications. In this event, the contractor shall directly bill Level 3 for the space enclosure, and this fee shall not be applicable.
- (4) **Co-Carrier Cross-Connect.** As stated in Section 5 of the Collocation Attachment, Level 3 may connect to other CLECs within the designated Premises in addition to, and not in lieu of, interconnection to BellSouth services and facilities. Where BellSouth must construct a cable rack structure to house the Co-Carrier cross connection, construction charges will be applied on an individual case basis as described in Section 5.6.1 of the Collocation Attachment. BellSouth shall provide an estimate of these charges in the Application Response. Where an existing cable rack structure is in place and has sufficient capacity to accommodate the Co-Carrier cross-connection requested, the recurring charges as stated in this Exhibit A shall apply.

- (5) **Additional Engineering Fee:** BellSouth's additional engineering, and other labor costs associated with handling Level 3-requested modifications to requests in progress or augmentations to existing arrangements shall be recovered as Additional Engineering charges, under provisions in BellSouth's F.C.C. Number 1 Tariff, Sections 13.1 and 13.2. Should Additional Engineering rates not be included, Level 3 agrees not to make changes to collocation arrangement after a Bona Fide Firm Order is submitted.

EXHIBIT A: BELLSOUTH/CLEC-1 RATES – KENTUCKY
PHYSICAL COLLOCATION

Rates marked with an asterisk (*) are interim and are subject to true-up.

USOC	Rate Element Description	Unit	Recurring Rate (RC)	Non-Recurring Rate (NRC)
PE1BA	Application Fee	Per request	NA	\$9,926.72
PE1CA	Subsequent Application Fee (Note 1)	Per request	NA	\$1,600.00 Minimum
PE1BB	Space Preparation Fee (Note 2) Mechanical / HVAC*	Per ton (one ton minimum)		\$2,400.00
PE1SB	Ground Bar*	Per connection		\$720.00
PE1SC	Project Management*	Per arrangement		\$1,675.00
PE1SD	Cable Racking / Fiber Duct	Per arrangement, sq. ft.		ICB
PE1SE	Frame / Aisle Lighting	Per arrangement, sq. ft.		ICB
PE1S	Framework Ground Conductors	Per arrangement		ICB
PE1SH	Extraordinary Modifications	Per arrangement		ICB
PE1BW	Space Enclosure (Note 3) Welded Wire-mesh	Per first 100 sq. ft.	\$201.02	NA
PE1CW	Welded Wire-mesh	Per add'l 50 sq. ft.	\$20.42	NA
PE1PJ	Floor Space	Per sq. ft.	\$5.00	NA
PE1BD	Cable Installation	Per cable	NA	\$2,327.08
PE1PM	Cable Support Structure	Per entrance cable	\$24.23	NA
PE1PL	Power -48V DC Power	Per amp	\$7.68	ICB
PE1FB	120V AC Power single phase*	Per breaker amp	\$5.50	ICB
PE1FD	240V AC Power single phase*	Per breaker amp	\$11.00	ICB
PE1FE	120V AC Power three phase*	Per breaker amp	\$16.50	ICB
PE1FG	277 AC Power three phase*	Per breaker amp	\$38.20	ICB
PE1P2	Cross Connects 2-wire	Per cross connect	\$0.31	First/Add'l \$54.21/\$51.07
PE1P4	4-wire		\$0.62	\$54.23/\$50.96
PE1P1	DS-1		\$1.92	\$99.23/\$69.15
PE1P3	DS-3		\$39.94	\$97.48/\$66.90
PE1F2	2-fiber		\$15.64	\$41.56/\$29.82
PE1F4	4-fiber		\$28.11	\$50.53/\$38.78

KENTUCKY (continued)				
USOC	Rate Element Description	Unit	Recurring Rate (RC)	Non-Recurring Rate (NRC)
PE1ES Fiber	Co-Carrier Cross-Connect (Note 4) Fiber Cable Support Structure, existing	Per linear ft.	\$0.06	NA
PE1DS Copper (TBD)	Copper or Coaxial Cable Support Structure, existing Cable Support Structure Construction, new	Per linear ft. Per new construction	\$0.03 NA	NA ICB
PE1AX	Security Access System Security System*	Per premises	\$52.00	
PE1AA	New Access Card Activation Administrative change, existing card	Per card Per card		\$55.00 \$35.00
PE1AR	Replace lost or stolen card	Per card		\$250.00
PE1SR	Space Availability Report	Per premises requested		\$550.00
PE1PE	POT Bay Arrangements <i>Prior to 6/1/99</i> 2-Wire Cross-Connect	Per cross-connect	\$0.06	NA
PE1PF	4-Wire Cross-Connect		\$0.15	NA
PE1PG	DS1 Cross-Connect		\$0.58	NA
PE1PH	DS3 Cross-Connect		\$4.51	NA
PE1B2	2 Fiber Cross-Connect		\$38.79	NA
PE1B4	4 Fiber Cross-Connect		\$52.31	NA
PE1BT	Security Escort Basic Time	Per half hr./Add'l half hr.	NA	\$56.09/\$31.99
PE1OT	Overtime		NA	\$67.75/\$39.00
PE1PT	Premium Time		NA	\$79.41/\$46.01
AEH	Additional Engineering Fee (Note 5)	Per request, first half hr/add'l half hr.		First/Add'l Basic Time \$31.00/\$22.00 Overtime \$37.00/\$26.00

EXHIBIT A: BELLSOUTH/CLEC-1 RATES – KENTUCKY
PHYSICAL COLLOCATION (continued)

Note(s):

N/A refers to rate elements which do not have a negotiated rate.

- (1) **Subsequent Application Fee:** BellSouth requires the submission of an Application Fee for modifications to an existing arrangement. However, when the modifications do not require BellSouth to expend capital, BellSouth will assess the Subsequent Application Fee in lieu of the Application Fee. Proposed modifications that could result in assessment of a Subsequent Application Fee would cause BellSouth to analyze the following but are not limited to: floor loading changes, changes to HVAC requirements, power requirement changes which may result in a power plant upgrade, environmental or safety requirements, or equipment relocation. Should the Subsequent Application Fee not be included as part of this Attachment, CLEC-1 will be assessed the full Application Fee for all subsequent activity for completed arrangements.
- (2) **Space Preparation Fee:** The Space Preparation Fee is a one-time fee, assessed per arrangement, per location. It recovers the costs associated with the shared physical collocation area within a Premises, which include survey, engineering, design and modification costs for network, building and support systems. In the event CLEC-1 opts for non-enclosed space, the space preparation fee will be assessed based on the total floor space dedicated to CLEC-1 as prescribed in Section 7 of the Collocation Attachment.
- (3) **Space Enclosure Fee:** The Space Enclosure Construction Fee is a one-time fee, assessed per enclosure, per location with a one-hundred (100) square foot minimum enclosure. It recovers costs associated with providing an optional equipment arrangement enclosure, which include architectural and engineering fees, materials, and installation costs. The cost for additional square feet is applicable only when ordered with the first 100 square feet and must be requested in fifty (50) square foot increments. CLEC-1 may, at its option, arrange with a BellSouth Certified Contractor to construct the space enclosure in accordance with BellSouth's guidelines and specifications. In this event, the BellSouth Certified Contractor shall directly bill CLEC-1 for the space enclosure, and this fee shall not be applicable.
- (4) **Co-Carrier Cross-Connect.** As stated in Section 5 of the Collocation Attachment, CLEC-1 may connect to other CLECs within the designated Premises in addition to, and not in lieu of, interconnection to BellSouth services and facilities. Where BellSouth must construct a cable rack structure to house the Co-Carrier cross-connection, construction charges will be applied on an individual case basis as described in Section 5.6.1 of the Collocation Attachment. BellSouth shall provide an estimate of these charges in the Application Response. Where an existing cable rack structure is in place and has sufficient capacity to accommodate the Co-Carrier cross-connection requested, the recurring charges as stated in this Exhibit A shall apply.

EXHIBIT A: BELLSOUTH/CLEC-1 RATES – KENTUCKY
PHYSICAL COLLOCATION (continued)

- (5) **Additional Engineering Fee:** BellSouth's additional engineering, and other labor costs associated with handling CLEC-1-requested modifications to requests in progress or augmentations to existing arrangements shall be recovered as Additional Engineering charges, under provisions in BellSouth's F.C.C. Number 1 Tariff, Sections 13.1 and 13.2. Should Additional Engineering rates not be included, CLEC-1 agrees not to make changes to collocation arrangement after a Bona Fide Firm Order is submitted.

EXHIBIT A: BELLSOUTH/CLEC-1 RATES – LOUISIANA
PHYSICAL COLLOCATION

Rates marked with an asterisk (*) are interim and are subject to true-up.

USOC	Rate Element Description	Unit	Recurring Rate (RC)	Non-Recurring Rate (NRC)
PE1BA	Application Fee	Per request	NA	\$4,910.00
PE1CA	Subsequent Application Fee (Note 1)	Per request	NA	\$1,600.00 Minimum
PE1BB	Space Preparation Fee (Note 2) Mechanical / HVAC*	Per ton (one ton minimum)		\$2,400.00
PE1SB	Ground Bar*	Per connection		\$720.00
PE1SC	Project Management*	Per arrangement		\$1,675.00
PE1SD	Cable Racking / Fiber Duct	Per arrangement, sq. ft.		ICB
PE1SE	Frame / Aisle Lighting	Per arrangement, sq. ft.		ICB
PE1S	Framework Ground Conductors	Per arrangement		ICB
PE1SH	Extraordinary Modifications	Per arrangement		ICB
PE1BW	Space Enclosure (Note 3) Welded Wire-mesh	Per first 100 sq. ft.	\$197.55	NA
PE1CW	Welded Wire-mesh	Per add'l 50 sq. ft.	\$20.07	NA
PE1PJ	Floor Space	Per sq. ft.	\$4.01	NA
PE1BD	Cable Installation	Per cable	NA	\$1,706.00 Disconnect charge \$36.00
PE1PM	Cable Support Structure	Per entrance cable	\$24.05	NA
PE1PL	Power -48V DC Power	Per amp	\$7.15	ICB
PE1FB	120V AC Power single phase*	Per breaker amp	\$5.50	ICB
PE1FD	240V AC Power single phase*	Per breaker amp	\$11.00	ICB
PE1FE	120V AC Power three phase*	Per breaker amp	\$16.50	ICB
PE1FG	277 AC Power three phase*	Per breaker amp	\$38.20	ICB
PE1P2	Cross Connects (Note 4) 2-wire	Per cross connect	\$0.26	First/Add'l \$23.04/\$22.11
PE1P4	4-wire		\$0.52	\$23.23/\$22.24
PE1P1	DS-1		\$2.03	\$43.61/\$30.60
PE1P3	DS-3		\$36.27	\$41.46/\$29.20

LOUISIANA (continued)				
USOC	Rate Element Description	Unit	Recurring Rate (RC)	Non-Recurring Rate (NRC)
PE1F2 PE1F4	Cross Connects (continued) 2-fiber 4-fiber	Per cross connect	\$19.13 \$34.38	First/Add'l \$41.07/\$29.63 \$49.81/\$38.37
	2-wire 4-wire DS-1 DS-3 2-fiber 4-fiber			Disconnect Charges First/Add'l \$9.48/\$8.54 \$9.53/\$8.55 \$9.56/\$8.63 \$11.06/\$8.86 \$12.84/\$10.29 \$16.75/\$14.20
PE1ES Fiber PE1DS Copper (TBD)	Co-Carrier Cross-Connect (Note 5) Fiber Cable Support Structure, existing Copper or Coaxial Cable Support Structure, existing Cable Support Structure Construction, new	Per linear ft. Per linear ft. Per new construction	\$0.06 \$0.03 NA	NA NA ICB
PE1AX PE1AA PE1AR	Security Access System Security System* New Access Card Activation* Administrative change, existing card* Replace lost or stolen card	Per premises Per card Per card	\$52.00	\$55.00 \$35.00 \$250.00
PE1SR	Space Availability Report*	Per premises requested		\$550.00
PE1PE PE1PF PE1PG PE1PH PE1B2 PE1B4	POT Bay Arrangements <i>Prior to 6/1/99</i> 2-Wire Cross-Connect 4-Wire Cross-Connect DS1 Cross-Connect DS3 Cross-Connect 2 Fiber Cross-Connect 4 Fiber Cross-Connect	Per cross-connect	\$0.0776 \$0.1552 \$0.6406 \$4.75 \$47.44 \$63.97	NA NA NA NA NA NA

LOUISIANA (continued)				
USOC	Rate Element Description	Unit	Recurring Rate (RC)	Non-Recurring Rate (NRC)
	Security Escort	Per half hr./Add'l half hr.		
PE1BT	Basic Time		NA	\$32.35/\$19.95
PE1OT	Overtime		NA	\$40.50/\$25.00
PE1PT	Premium Time		NA	\$48.66/\$30.05
AEH	Additional Engineering Fee (Note 6)	Per request, first half hr/add'l half hr.		First/Add'l Basic Time \$31.00/\$22.00 Overtime \$37.00/\$26.00

Note(s):

N/A refers to rate elements which do not have a negotiated rate.

- (1) **Subsequent Application Fee:** BellSouth requires the submission of an Application Fee for modifications to an existing arrangement. However, when the modifications do not require BellSouth to expend capital, BellSouth will assess the Subsequent Application Fee in lieu of the Application Fee. Proposed modifications that could result in assessment of a Subsequent Application Fee would cause BellSouth to analyze the following but are not limited to: floor loading changes, changes to HVAC requirements, power requirement changes which may result in a power plant upgrade, environmental or safety requirements, or equipment relocation. Should the Subsequent Application Fee not be included as part of this Attachment, CLEC-1 will be assessed the full Application Fee for all subsequent activity for completed arrangements.
- (2) **Space Preparation Fee:** The Space Preparation Fee is a one-time fee, assessed per arrangement, per location. It recovers the costs associated with the shared physical collocation area within a Premises, which include survey, engineering, design and modification costs for network, building and support systems. In the event CLEC-1 opts for non-enclosed space, the space preparation fee will be assessed based on the total floor space dedicated to CLEC-1 as prescribed in Section 7 of the Collocation Attachment.
- (3) **Space Enclosure Fee:** The Space Enclosure Construction Fee is a monthly recurring fee, assessed per enclosure, per location with a one-hundred (100) square foot minimum enclosure. It recovers costs associated with providing an optional equipment arrangement enclosure, which include architectural and engineering fees, materials, and installation costs. The cost for additional square feet is applicable only when ordered with the first 100 square feet and must be requested in fifty (50) square foot increments. CLEC-1 may, at its option, arrange with a BellSouth Certified Contractor to construct the space enclosure in accordance with BellSouth's guidelines and specifications. In this event, the BellSouth Certified Contractor shall directly bill CLEC-1 for the space enclosure, and this fee shall not be applicable.

EXHIBIT A: BELLSOUTH/CLEC-1 RATES – LOUISIANA
PHYSICAL COLLOCATION (continued)

- (4) **Cross Connects:** The charges for cross connects are for orders placed electronically. Cross connect elements may also be ordered manually for which there is an additional charge per element.

	First / Additional	Disconnect Charges First / Additional
2-wire	\$24.92/\$23.99	\$10.56/\$9.62
4-wire	\$25.11/\$24.12	\$10.61/\$9.63
DS-1	\$45.49/\$32.48	\$10.64/\$9.71
DS-3	\$43.34/\$31.08	\$12.14/\$9.94

- (5) **Co-Carrier Cross-Connect.** As stated in Section 5 of the Collocation Attachment, CLEC-1 may connect to other CLECs within the designated Premises in addition to, and not in lieu of, interconnection to BellSouth services and facilities. Where BellSouth must construct a cable rack structure to house the Co-Carrier cross-connection, construction charges will be applied on an individual case basis as described in Section 5.6.1 of the Collocation Attachment. BellSouth shall provide an estimate of these charges in the Application Response. Where an existing cable rack structure is in place and has sufficient capacity to accommodate the Co-Carrier cross-connection requested, the recurring charges as stated in this Exhibit A shall apply.
- (6) **Additional Engineering Fee:** BellSouth's additional engineering, and other labor costs associated with handling CLEC-1-requested modifications to requests in progress or augmentations to existing arrangements shall be recovered as Additional Engineering charges, under provisions in BellSouth's F.C.C. Number 1 Tariff, Sections 13.1 and 13.2. Should Additional Engineering rates not be included, CLEC-1 agrees not to make changes to collocation arrangement after a Bona Fide Firm Order is submitted.

EXHIBIT A: BELLSOUTH/CLEC-1 RATES – MISSISSIPPI
PHYSICAL COLLOCATION

Rates marked with an asterisk (*) are interim and are subject to true-up.

USOC	Rate Element Description	Unit	Recurring Rate (RC)	Non-Recurring Rate (NRC)
PE1BA	Application Fee	Per request	NA	\$6,993.00 Disconnect Charge \$1.70
PE1CA	Subsequent Application Fee (Note 1)	Per request	NA	\$1,600.00 Minimum
PE1BB	Space Preparation Fee (Note 2) Mechanical / HVAC*	Per ton (one ton minimum)		\$2,400.00
PE1SB	Ground Bar*	Per connection		\$720.00
PE1SC	Project Management*	Per arrangement		\$1,675.00
PE1SD	Cable Racking / Fiber Duct	Per arrangement, sq. ft.		ICB
PE1SE	Frame / Aisle Lighting	Per arrangement, sq. ft.		ICB
PE1S	Framework Ground Conductors	Per arrangement		ICB
PE1SH	Extraordinary Modifications	Per arrangement		ICB
PE1BW	Space Enclosure (Note 3) Welded Wire-mesh	Per first 100 sq. ft.	\$205.08	NA
PE1CW	Welded Wire-mesh	Per add'l 50 sq. ft.	\$20.83	NA
PE1PJ	Floor Space	Per sq. ft.	\$3.45	
PE1BD	Cable Installation	Per cable	NA	\$2,419.00 Disconnection charge \$53.24
PE1PM	Cable Support Structure	Per entrance cable	\$22.90	NA
PE1PL	Power -48V DC Power	Per amp	\$6.93	ICB
PE1FB	120V AC Power single phase*	Per breaker amp	\$5.50	ICB
PE1FD	240V AC Power single phase*	Per breaker amp	\$11.00	ICB
PE1FE	120V AC Power three phase*	Per breaker amp	\$16.50	ICB
PE1FG	277 AC Power three phase*	Per breaker amp	\$38.20	ICB
PE1P2	Cross Connects (Note 4) 2-wire	Per cross connect	\$.3996	First/Add'l \$30.93/\$29.59
PE1P4	4-wire		\$.7992	\$31.17/\$29.77

MISSISSIPPI (continued)				
USOC	Rate Element Description	Unit	Recurring Rate (RC)	Non-Recurring Rate (NRC)
	Cross Connects (continued)	Per cross connect		First/Add'l
PE1P1	DS-1		\$2.90	\$60.42/\$41.68
PE1P3	DS-3		\$53.31	\$57.45/\$39.81
PE1F2	2-fiber		\$15.64	\$41.56/\$29.82
PE1F4	4-fiber		\$28.11	\$50.53/\$38.78
				Disconnect Charges
				First/Add'l
	2-wire			\$12.76/\$11.43
	4-wire			\$12.83/\$11.43
	DS-1			\$12.87/\$11.54
	DS-3			\$14.92/\$11.80
	2-fiber			\$12.96/\$10.34
	4-fiber			\$16.97/\$14.35
PE1ES	Co-Carrier Cross-Connect (Note 5)			
Fiber	Fiber Cable Support Structure, existing	Per linear ft.	\$0.06	NA
PE1DS	Copper or Coaxial Cable Support Structure, existing	Per linear ft.	\$0.03	NA
Copper (TBD)	Cable Support Structure Construction, new	Per new construction	NA	ICB
PE1AX	Security Access System Security System*	Per premises	\$52.00	
	New Access Card Activation*	Per card		\$55.00
PE1AA	Administrative change, existing card*	Per card		\$35.00
PE1AR	Replace lost or stolen card	Per card		\$250.00
PE1SR	Space Availability Report*	Per premises requested		\$550.00
	POT Bay Arrangements <i>Prior to 6/1/99</i>	Per cross-connect		
PE1PE	2-Wire Cross-Connect		\$0.1195	NA
PE1PF	4-Wire Cross-Connect		\$0.2389	NA
PE1PG	DS1 Cross-Connect		\$0.9862	NA
PE1PH	DS3 Cross-Connect		\$5.81	NA
PE1B2	2 Fiber Cross-Connect		\$38.79	NA
PE1B4	4 Fiber Cross-Connect		\$52.31	NA

MISSISSIPPI (continued)				
USOC	Rate Element Description	Unit	Recurring Rate (RC)	Non-Recurring Rate (NRC)
	Security Escort	Per half hr./Add'l half hr.		
PE1BT	Basic Time		NA	\$42.87/\$25.54
PE1OT	Overtime		NA	\$54.43/\$32.41
PE1PT	Premium Time		NA	\$65.99/\$39.28
AEH	Additional Engineering Fee (Note 6)	Per request, first half hr/add'l half hr.		First/Add'l Basic Time \$31.00/\$22.00 Overtime \$37.00/\$26.00

Note(s):

N/A refers to rate elements which do not have a negotiated rate.

- (1) **Subsequent Application Fee:** BellSouth requires the submission of an Application Fee for modifications to an existing arrangement. However, when the modifications do not require BellSouth to expend capital, BellSouth will assess the Subsequent Application Fee in lieu of the Application Fee. Proposed modifications that could result in assessment of a Subsequent Application Fee would cause BellSouth to analyze the following but are not limited to: floor loading changes, changes to HVAC requirements, power requirement changes which may result in a power plant upgrade, environmental or safety requirements, or equipment relocation. Should the Subsequent Application Fee not be included as part of this Attachment, CLEC-1 will be assessed the full Application Fee for all subsequent activity for completed arrangements.
- (2) **Space Preparation Fee:** The Space Preparation Fee is a one-time fee, assessed per arrangement, per location. It recovers the costs associated with the shared physical collocation area within a Premises, which include survey, engineering, design and modification costs for network, building and support systems. In the event CLEC-1 opts for non-enclosed space, the space preparation fee will be assessed based on the total floor space dedicated to CLEC-1 as prescribed in Section 7 of the Collocation Attachment.
- (3) **Space Enclosure Fee:** The Space Enclosure Construction Fee is a monthly recurring fee, assessed per enclosure, per location with a one-hundred (100) square foot minimum enclosure. It recovers costs associated with providing an optional equipment arrangement enclosure, which include architectural and engineering fees, materials, and installation costs. The cost for additional square feet is applicable only when ordered with the first 100 square feet and must be requested in fifty (50) square foot increments. CLEC-1 may, at its option, arrange with a BellSouth Certified Contractor to construct the space enclosure in accordance with BellSouth's guidelines and specifications. In this event, the BellSouth Certified Contractor shall directly bill CLEC-1 for the space enclosure, and this fee shall not be applicable.

EXHIBIT A: BELLSOUTH/CLEC-1 RATES – MISSISSIPPI
PHYSICAL COLLOCATION (continued)

- (4) **Cross Connects:** The charges for cross connects are for orders placed electronically. Cross connect elements may also be ordered manually for which there is an additional charge per element.

	First / Additional	Disconnect Charges First / Additional
2-wire	\$33.58 / \$32.24	\$14.27 / \$12.94
4-wire	\$33.82 / \$32.42	\$14.34 / \$12.94
DS-1	\$63.07 / \$44.33	\$14.38 / \$13.05
DS-3	\$60.10 / \$42.46	\$16.43 / \$13.31

- (5) **Co-Carrier Cross-Connect.** As stated in Section 5 of the Collocation Attachment, CLEC-1 may connect to other CLECs within the designated Premises in addition to, and not in lieu of, interconnection to BellSouth services and facilities. Where BellSouth must construct a cable rack structure to house the Co-Carrier cross-connection, construction charges will be applied on an individual case basis as described in Section 5.6.1 of the Collocation Attachment. BellSouth shall provide an estimate of these charges in the Application Response. Where an existing cable rack structure is in place and has sufficient capacity to accommodate the Co-Carrier cross-connection requested, the recurring charges as stated in this Exhibit A shall apply.
- (6) **Additional Engineering Fee:** BellSouth's additional engineering, and other labor costs associated with handling CLEC-1-requested modifications to requests in progress or augmentations for existing arrangements shall be recovered as Additional Engineering charges, under provisions in BellSouth's F.C.C. Number 1 Tariff, Sections 13.1 and 13.2. Should Additional Engineering rates not be included, CLEC-1 agrees not to make changes to collocation arrangement after a Bona Fide Firm Order is submitted.

EXHIBIT A: BELLSOUTH/CLEC-1 RATES – NORTH CAROLINA
PHYSICAL COLLOCATION

Rates marked with an asterisk (*) are interim and are subject to true-up.

USOC	Rate Element Description	Unit	Recurring Rate (RC)	Non-Recurring Rate (NRC)
PE1BA	Application Fee	Per request	NA	\$3,850.00
PE1CA	Subsequent Application Fee (Note 1)	Per request	NA	\$1,600.00 Minimum
	Space Preparation Fee			
	Central Office Modification	Per sq. ft.	\$1.57	
	Common Systems Modification – Cageless	Per sq. ft.	\$3.26	
	Common Systems Modification – Caged	Per cage	\$110.79	
	Power	Per nominal –48v DC Amp	\$5.76	
PE1BW	Space Enclosure (Note 2) Welded Wire-mesh	Per first 100 sq. ft.	\$102.76	NA
PE1CW	Welded Wire-mesh	Per add'l 50 sq. ft.	\$10.44	NA
PE1PJ	Floor Space	Per sq. ft.	\$3.45	NA
PE1BD	Cable Installation	Per cable	NA	\$2,305.00
PE1PM	Cable Support Structure	Per entrance cable	\$21.33	NA
PE1PL	Power -48V DC Power	Per amp	\$6.65	ICB
PE1FB	120V AC Power single phase*	Per breaker amp	\$5.50	ICB
PE1FD	240V AC Power single phase*	Per breaker amp	\$11.00	ICB
PE1FE	120V AC Power three phase*	Per breaker amp	\$16.50	ICB
PE1FG	277 AC Power three phase*	Per breaker amp	\$38.20	ICB
PE1P2	Cross Connects (Note 3) 2-wire	Per cross connect	\$0.32	First/Add'l \$41.78/\$39.23
PE1P4	4-wire		\$0.64	\$41.91/\$39.25
PE1P1	DS-1		\$2.34	\$71.02/\$51.08
PE1P3	DS-3		\$42.84	\$69.84/\$49.43
PE1F2	2-fiber		\$15.99	\$67.34/\$48.55
PE1F4	4-fiber		\$28.74	\$82.35/\$63.56

NORTH CAROLINA (continued)				
USOC	Rate Element Description	Unit	Recurring Rate (RC)	Non-Recurring Rate (NRC)
PE1ES	Co-Carrier Cross-Connect (Note 4) Fiber Cable Support Structure, existing	Per linear ft.	\$0.06	NA
PE1DS	Copper or Coaxial Cable Support Structure, existing	Per linear ft.	\$0.03	NA
(TBD)	Cable Support Structure Construction, new	Per new construction	NA	ICB
PE1AX	Security Access System Security System*	Per premises	\$52.00	
PE1AA	New Access Card Activation* Administrative change, existing card*	Per card Per card		\$55.00 \$35.00
PE1AR	Replace lost or stolen card	Per card		\$250.00
PE1SR	Space Availability Report*	Per premises requested		\$550.00
PE1PE	POT Bay Arrangements <i>Prior to 6/1/99</i> 2-Wire Cross-Connect	Per cross-connect	\$0.10	NA
PE1PF	4-Wire Cross-Connect		\$0.19	NA
PE1PG	DS1 Cross-Connect		\$0.79	NA
PE1PH	DS3 Cross-Connect		\$4.85	NA
PE1B2	2 Fiber Cross-Connect		\$39.67	NA
PE1B4	4 Fiber Cross-Connect		\$53.49	NA
PE1BT	Security Escort Basic Time	Per half hr./Add'l half hr.	NA	\$42.92/\$25.56
PE1OT	Overtime		NA	\$54.51/\$32.44
PE1PT	Premium Time		NA	\$66.10/\$39.32
AEH	Additional Engineering Fee (Note 5)	Per request, first half hr/add'l half hr.		First/Add'l Basic Time \$31.00/\$22.00 Overtime \$37.00/\$26.00

EXHIBIT A: BELLSOUTH/CLEC-1 RATES – NORTH CAROLINA
PHYSICAL COLLOCATION (continued)

Note(s):

N/A refers to rate elements which do not have a negotiated rate.

- (1) **Subsequent Application Fee:** BellSouth requires the submission of an Application Fee for modifications to an existing arrangement. However, when the modifications do not require BellSouth to expend capital, BellSouth will assess the Subsequent Application Fee in lieu of the Application Fee. Proposed modifications that could result in assessment of a Subsequent Application Fee would cause BellSouth to analyze the following but are not limited to: floor loading changes, changes to HVAC requirements, power requirement changes which may result in a power plant upgrade, environmental or safety requirements, or equipment relocation. Should the Subsequent Application Fee not be included as part of this Attachment, CLEC-1 will be assessed the full Application Fee for all subsequent activity for completed arrangements.
- (2) **Space Enclosure Fee:** The Space Enclosure Construction Fee is a monthly recurring fee, assessed per enclosure, per location with a one-hundred (100) square foot minimum enclosure. It recovers costs associated with providing an optional equipment arrangement enclosure, which include architectural and engineering fees, materials, and installation costs. The cost for additional square feet is applicable only when ordered with the first 100 square feet and must be requested in fifty (50) square foot increments. CLEC-1 may, at its option, arrange with a BellSouth Certified Contractor to construct the space enclosure in accordance with BellSouth's guidelines and specifications. In this event, the BellSouth Certified Contractor shall directly bill CLEC-1 for the space enclosure, and this fee shall not be applicable.
- (3) **Cross Connect:** The charges for cross connects are for orders placed electronically. Cross connect elements may also be ordered manually for which there is an additional charge per element.

	<u>First/Additional</u>
2-wire	\$46.53/\$43.98
4-wire	\$46.64/\$43.98
DS-1	\$75.72/\$55.78
DS-3	\$74.54/\$54.13

- (4) **Co-Carrier Cross-Connect.** As stated in Section 5 of the Collocation Attachment, CLEC-1 may connect to other CLECs within the designated Premises in addition to, and not in lieu of, interconnection to BellSouth services and facilities. Where BellSouth must construct a cable rack structure to house the Co-Carrier cross-connection, construction charges will be applied on an individual case basis as described in Section 5.6.1 of the Collocation Attachment. BellSouth shall provide an estimate of these charges in the Application Response. Where an existing cable rack structure is in place and has sufficient capacity to accommodate the Co-Carrier cross-connection requested, the recurring charges as stated in this Exhibit A shall apply.

EXHIBIT A: BELLSOUTH/CLEC-1 RATES – NORTH CAROLINA
PHYSICAL COLLOCATION (continued)

- (5) **Additional Engineering Fee:** BellSouth's additional engineering, and other labor costs associated with handling CLEC-1-requested modifications to requests in progress or augmentations for existing arrangements shall be recovered as Additional Engineering charges, under provisions in BellSouth's F.C.C. Number 1 Tariff, Sections 13.1 and 13.2. Should Additional Engineering rates not be included, CLEC-1 agrees not to make changes to collocation arrangement after a Bona Fide Firm Order is submitted.

EXHIBIT A: BELLSOUTH/CLEC-1 RATES – SOUTH CAROLINA
PHYSICAL COLLOCATION

Rates marked with an asterisk (*) are interim and are subject to true-up.

USOC	Rate Element Description	Unit	Recurring Rate (RC)	Non-Recurring Rate (NRC)
PE1BA	Application Fee	Per request	NA	\$4,850.00
PE1CA	Subsequent Application Fee (Note 1)	Per request	NA	\$1,600.00 Minimum
PE1BB	Space Preparation Fee (Note 2) Mechanical / HVAC*	Per ton (one ton minimum)		\$2,400.00
PE1SB	Ground Bar*	Per connection		\$720.00
PE1SC	Project Management*	Per arrangement		\$1,675.00
PE1SD	Cable Racking / Fiber Duct	Per arrangement, sq. ft.		ICB
PE1SE	Frame / Aisle Lighting	Per arrangement, sq. ft.		ICB
PE1S	Framework Ground Conductors	Per arrangement		ICB
PE1SH	Extraordinary Modifications	Per arrangement		ICB
PE1BW	Space Enclosure (Note 3) Welded Wire-mesh	Per first 100 sq. ft.	\$224.60	NA
PE1CW	Welded Wire-mesh	Per add'l 50 sq. ft.	\$22.81	NA
PE1PJ	Floor Space	Per sq. ft.	\$3.90	NA
PE1BD	Cable Installation	Per cable	NA	\$2,217.00
PE1PM	Cable Support Structure	Per entrance cable	\$24.55	NA
PE1PL	Power -48V DC Power	Per amp	\$7.09	ICB
PE1FB	120V AC Power single phase*	Per breaker amp	\$5.50	ICB
PE1FD	240V AC Power single phase*	Per breaker amp	\$11.00	ICB
PE1FE	120V AC Power three phase*	Per breaker amp	\$16.50	ICB
PE1FG	277 AC Power three phase*	Per breaker amp	\$38.20	ICB
PE1P2	Cross Connects (Note 4) 2-wire	Per cross connect	\$.3648	First/Add'l \$41.50/\$38.94
PE1P4	4-wire		\$.7297	\$41.56/\$38.90
PE1P1	DS-1		\$2.70	\$70.79/\$50.78
PE1P3	DS-3		\$49.24	\$69.60/\$49.14
PE1F2	2-fiber		\$15.06	\$69.28/\$48.89
PE1F4	4-fiber		\$27.08	\$84.07/\$63.68

SOUTH CAROLINA (continued)				
USOC	Rate Element Description	Unit	Recurring Rate (RC)	Non-Recurring Rate (NRC)
PE1ES	Co-Carrier Cross-Connect (Note 5) Fiber Cable Support Structure, existing	Per linear ft.	\$0.06	NA
PE1DS	Copper or Coaxial Cable Support Structure, existing	Per linear ft.	\$0.03	NA
(TBD)	Cable Support Structure Construction, new	Per new construction	NA	ICB
PE1AX	Security Access System Security System*	Per premises	\$52.00	
PE1AA	New Access Card Activation* Administrative change, existing card*	Per card Per card		\$55.00 \$35.00
PE1AR	Replace lost or stolen card	Per card		\$250.00
PE1SR	Space Availability Report*	Per premises requested		\$550.00
PE1PE	POT Bay Arrangements <i>Prior to 6/1/99</i> 2-Wire Cross-Connect	Per cross-connect	\$0.1091	NA
PE1PF	4-Wire Cross-Connect		\$0.2181	NA
PE1PG	DS1 Cross-Connect		\$0.9004	NA
PE1PH	DS3 Cross-Connect		\$5.64	NA
PE1B2	2 Fiber Cross-Connect		\$37.36	NA
PE1B4	4 Fiber Cross-Connect		\$50.38	NA
PE1BT	Security Escort Basic Time	Per half hr./Add'l half hr.	NA	\$43.00/\$25.57
PE1OT	Overtime		NA	\$54.62/\$32.46
PE1PT	Premium Time		NA	\$66.24/\$39.35
AEH	Additional Engineering Fee (Note 6)	Per request, first half hr/add'l half hr.		First/Add'l Basic Time \$31.00/\$22.00 Overtime \$37.00/\$26.00

EXHIBIT A: BELLSOUTH/CLEC-1 RATES – SOUTH CAROLINA
PHYSICAL COLLOCATION (continued)

Note(s):

N/A refers to rate elements which do not have a negotiated rate.

- (1) **Subsequent Application Fee:** BellSouth requires the submission of an Application Fee for modifications to an existing arrangement. However, when the modifications do not require BellSouth to expend capital, BellSouth will assess the Subsequent Application Fee in lieu of the Application Fee. Proposed modifications that could result in assessment of a Subsequent Application Fee would cause BellSouth to analyze the following but are not limited to: floor loading changes, changes to HVAC requirements, power requirement changes which may result in a power plant upgrade, environmental or safety requirements, or equipment relocation. Should the Subsequent Application Fee not be included as part of this Attachment, CLEC-1 will be assessed the full Application Fee for all subsequent activity for completed arrangements.
- (2) **Space Preparation Fee:** The Space Preparation Fee is a one-time fee, assessed per arrangement, per location. It recovers the costs associated with the shared physical collocation area within a Premises, which include survey, engineering, design and modification costs for network, building and support systems. In the event CLEC-1 opts for non-enclosed space, the space preparation fee will be assessed based on the total floor space dedicated to CLEC-1 as prescribed in Section 7 of the Collocation Attachment.
- (3) **Space Enclosure Fee:** The Space Enclosure Construction Fee is a monthly recurring fee, assessed per enclosure, per location with a one-hundred (100) square foot minimum enclosure. It recovers costs associated with providing an optional equipment arrangement enclosure, which include architectural and engineering fees, materials, and installation costs. The cost for additional square feet is applicable only when ordered with the first 100 square feet and must be requested in fifty (50) square foot increments. CLEC-1 may, at its option, arrange with a BellSouth Certified Contractor to construct the space enclosure in accordance with BellSouth's guidelines and specifications. In this event, the BellSouth Certified Contractor shall directly bill CLEC-1 for the space enclosure, and this fee shall not be applicable.
- (4) **Cross Connects:** The charges for cross connects are for orders placed electronically. Cross connect elements may also be ordered manually for which there is an additional charge per element.

	<u>First / Additional</u>
2-wire	\$46.66 / \$44.10
4-wire	\$46.68 / \$44.02
DS-1	\$75.88 / \$55.87
DS-3	\$74.69 / \$54.23

EXHIBIT A: BELLSOUTH/CLEC-1 RATES – SOUTH CAROLINA
PHYSICAL COLLOCATION (continued)

- (5) **Co-Carrier Cross-Connect.** As stated in Section 5 of the Collocation Attachment, CLEC-1 may connect to other CLECs within the designated Premises in addition to, and not in lieu of, interconnection to BellSouth services and facilities. Where BellSouth must construct a cable rack structure to house the Co-Carrier cross-connection, construction charges will be applied on an individual case basis as described in Section 5.6.1 of the Collocation Attachment. BellSouth shall provide an estimate of these charges in the Application Response. Where an existing cable rack structure is in place and has sufficient capacity to accommodate the Co-Carrier cross-connection requested, the recurring charges as stated in this Exhibit A shall apply.
- (6) **Additional Engineering Fee:** BellSouth's additional engineering, and other labor costs associated with handling CLEC-1-requested modifications to requests in progress or augmentations to existing arrangements shall be recovered as Additional Engineering charges, under provisions in BellSouth's F.C.C. Number 1 Tariff, Sections 13.1 and 13.2. Should Additional Engineering rates not be included, CLEC-1 agrees not to make changes to collocation arrangement after a Bona Fide Firm Order is submitted.

EXHIBIT A: BELLSOUTH/CLEC-1 RATES – TENNESSEE
PHYSICAL COLLOCATION

*** Rates are interim and are subject to true-up.**

USOC	Rate Element Description	Unit	Recurring Rate (RC)	Non-Recurring Rate (NRC)
PE1BA	Application Fee	Per request	NA	\$3,850.00
PE1CA	Subsequent Application Fee (Note 1)	Per request	NA	\$1,600.00 Minimum
PE1BB	Space Preparation Fee (Note 2) Mechanical / HVAC*	Per ton (one ton minimum)		\$2,400.00
PE1SB	Ground Bar*	Per connection		\$720.00
PE1SC	Project Management*	Per arrangement		\$1,675.00
PE1SD	Cable Racking / Fiber Duct	Per arrangement, sq. ft.		ICB
PE1SE	Frame / Aisle Lighting	Per arrangement, sq. ft.		ICB
PE1S	Framework Ground Conductors	Per arrangement		ICB
PE1SH	Extraordinary Modifications	Per arrangement		ICB
PE1BW	Space Enclosure (Note 3) Welded Wire-mesh	Per first 100 sq. ft.	\$190.79	NA
PE1CW	Welded Wire-mesh	Per add'l 50 sq. ft.	\$19.38	NA
PE1PJ	Floor Space	Per sq. ft.	\$7.50	NA
PE1BD	Cable Installation	Per cable	NA	\$2,750.00
PE1PM	Cable Support Structure	Per entrance cable	\$13.35	NA
PE1PL	Power -48V DC Power	Per amp	\$5.00	ICB
PE1FB	120V AC Power single phase*	Per breaker amp	\$5.50	ICB
PE1FD	240V AC Power single phase*	Per breaker amp	\$11.00	ICB
PE1FE	120V AC Power three phase*	Per breaker amp	\$16.50	ICB
PE1FG	277 AC Power three phase*	Per breaker amp	\$38.20	ICB
PE1P2	Cross Connects 2-wire	Per cross connect	\$0.30	First/Add'l \$19.20/\$19.20
PE1P4	4-wire		\$0.50	\$19.20/\$19.20
PE1P1	DS-1		\$8.00	\$155.00/\$27.00
PE1P3	DS-3		\$72.00	\$155.00/\$27.00
PE1F2	2-fiber		\$15.64	\$41.56/\$29.82
PE1F4	4-fiber		\$28.11	\$50.53/\$38.78

TENNESSEE (continued)				
USOC	Rate Element Description	Unit	Recurring Rate (RC)	Non-Recurring Rate (NRC)
PE1ES	Co-Carrier Cross-Connect (Note 4) Fiber Cable Support Structure, existing	Per linear ft.	\$0.06	NA
PE1DS	Copper or Coaxial Cable Support Structure, existing	Per linear ft.	\$0.03	NA
(TBD)	Cable Support Structure Construction, new	Per new construction	NA	ICB
PE1AX	Security Access System Security System	Per premises	\$52.00	
PE1AA	New Access Card Activation Administrative change, existing card	Per card Per card		\$55.00 \$35.00
PE1AR	Replace lost or stolen card	Per card		\$250.00
PE1SR	Space Availability Report*	Per premises requested		\$550.00
PE1PE	POT Bay Arrangements <i>Prior to 6/1/99</i> 2-Wire Cross-Connect	Per cross-connect	\$0.40	NA
PE1PF	4-Wire Cross-Connect		\$1.20	NA
PE1PG	DS1 Cross-Connect		\$1.20	NA
PE1PH	DS3 Cross-Connect		\$8.00	NA
PE1B2	2 Fiber Cross-Connect		\$38.79	NA
PE1B4	4 Fiber Cross-Connect		\$52.31	NA
PE1BT	Security Escort Basic Time	Per half hr./Add'l half hr.	NA	\$41.00/\$25.00
PE1OT	Overtime		NA	\$48.00/\$30.00
PE1PT	Premium Time		NA	\$55.00/\$35.00
AEH	Additional Engineering Fee (Note 5)	Per request, first half hr/add'l half hr.		First/Add'l Basic Time \$31.00/\$22.00 Overtime \$37.00/\$26.00

EXHIBIT A: BELLSOUTH/CLEC-1 RATES – TENNESSEE
PHYSICAL COLLOCATION (continued)

Note(s):

N/A refers to rate elements which do not have a negotiated rate.

- (1) **Subsequent Application Fee:** BellSouth requires the submission of an Application Fee for modifications to an existing arrangement. However, when the modifications do not require BellSouth to expend capital, BellSouth will assess the Subsequent Application Fee in lieu of the Application Fee. Proposed modifications that could result in assessment of a Subsequent Application Fee would cause BellSouth to analyze the following but are not limited to: floor loading changes, changes to HVAC requirements, power requirement changes which may result in a power plant upgrade, environmental or safety requirements, or equipment relocation. Should the Subsequent Application Fee not be included as part of this Attachment, CLEC-1 will be assessed the full Application Fee for all subsequent activity for completed arrangements.
- (2) **Space Preparation Fee:** The Space Preparation Fee is a one-time fee, assessed per arrangement, per location. It recovers the costs associated with the shared physical collocation area within a Premises, which include survey, engineering, design and modification costs for network, building and support systems. In the event CLEC-1 opts for non-enclosed space, the space preparation fee will be assessed based on the total floor space dedicated to CLEC-1 as prescribed in Section 7 of the Collocation Attachment.
- (3) **Space Enclosure Fee:** The Space Enclosure Construction Fee is a monthly recurring fee, assessed per enclosure, per location with a one-hundred (100) square foot minimum enclosure. It recovers costs associated with providing an optional equipment arrangement enclosure, which include architectural and engineering fees, materials, and installation costs. The cost for additional square feet is applicable only when ordered with the first 100 square feet and must be requested in fifty (50) square foot increments. CLEC-1 may, at its option, arrange with a BellSouth Certified Contractor to construct the space enclosure in accordance with BellSouth's guidelines and specifications. In this event, the BellSouth Certified Contractor shall directly bill CLEC-1 for the space enclosure, and this fee shall not be applicable.
- (4) **Co-Carrier Cross-Connect.** As stated in Section 5 of the Collocation Attachment, CLEC-1 may connect to other CLECs within the designated Premises in addition to, and not in lieu of, interconnection to BellSouth services and facilities. Where BellSouth must construct a cable rack structure to house the Co-Carrier cross-connection, construction charges will be applied on an individual case basis as described in Section 5.6.1 of the Collocation Attachment. BellSouth shall provide an estimate of these charges in the Application Response. Where an existing cable rack structure is in place and has sufficient capacity to accommodate the Co-Carrier cross-connection requested, the recurring charges as stated in this Exhibit A shall apply.

EXHIBIT A: BELLSOUTH/CLEC-1 RATES – TENNESSEE
PHYSICAL COLLOCATION (continued)

- (5) **Additional Engineering Fee:** BellSouth's additional engineering, and other labor costs associated with handling CLEC-1-requested modifications to requests in progress or augmentations for existing arrangements shall be recovered as Additional Engineering charges, under provisions in BellSouth's F.C.C. Number 1 Tariff, Sections 13.1 and 13.2. Should Additional Engineering rates not be included, CLEC-1 agrees not to make changes to collocation arrangement after a Bona Fide Firm Order is submitted.

ENVIRONMENTAL AND SAFETY PRINCIPLES

The following principles provide basic guidance on environmental and safety issues when applying for and establishing Physical Collocation arrangements.

1. GENERAL PRINCIPLES

- 1.1 Compliance with Applicable Law. BellSouth and Level 3 agree to comply with applicable federal, state, and local environmental and safety laws and regulations including U.S. Environmental Protection Agency (USEPA) regulations issued under the Clean Air Act (CAA), Clean Water Act (CWA), Resource Conservation and Recovery Act (RCRA), Comprehensive Environmental Response, Compensation and Liability Act (CERCLA), Superfund Amendments and Reauthorization Act (SARA), the Toxic Substances Control Act (TSCA), and OSHA regulations issued under the Occupational Safety and Health Act of 1970, as amended and NFPA and National Electrical Codes (NEC) and the NESC (“Applicable Laws”). Each party shall notify the other if compliance inspections are conducted by regulatory agencies and/or citations are issued that relate to any aspect of this agreement.
- 1.2 Notice. BellSouth and Level 3 shall provide notice to the other, including Material Safety Data Sheets (MSDSs), of known and recognized physical hazards or Hazardous Chemicals existing on site or brought on site. Each party is required to provide specific notice for known potential Imminent Danger conditions. Level 3 should contact 1-800-743-6737 for BellSouth MSDS sheets.
- 1.3 Practices/Procedures. BellSouth may make available additional environmental control procedures for Level 3 to follow when working at a BellSouth Premises (See Section 2, below). These practices/procedures will represent the regular work practices required to be followed by the employees and contractors of BellSouth for environmental protection. Level 3 will require its contractors, agents and others accessing the BellSouth Premises to comply with these practices. Section 2 lists the Environmental categories where BST practices should be followed by CLEC when operating in the BellSouth Premises.
- 1.4 Environmental and Safety Inspections. BellSouth reserves the right to inspect the Level 3 space with proper notification. BellSouth reserves the right to stop any Level 3 work operation that imposes Imminent Danger to the environment, employees or other persons in the area or Facility.
- 1.5 Hazardous Materials Brought On Site. Any hazardous materials brought into, used, stored or abandoned at the BellSouth Premises by Level 3 are owned by Level 3.

Level 3 will indemnify BellSouth for claims, lawsuits or damages to persons or property caused by these materials. Without prior written BellSouth approval, no substantial new safety or environmental hazards can be created by Level 3 or different hazardous materials used by Level 3 at BellSouth Facility. Level 3 must demonstrate adequate emergency response capabilities for its materials used or remaining at the BellSouth Facility.

EXHIBIT B

- 1.6 Spills and Releases. When contamination is discovered at a BellSouth Premises, the party discovering the condition must notify BellSouth. All Spills or Releases of regulated materials will immediately be reported by Level 3 to BellSouth.
- 1.7 Coordinated Environmental Plans and Permits. BellSouth and Level 3 will coordinate plans, permits or information required to be submitted to government agencies, such as emergency response plans, spill prevention control and countermeasures (SPCC) plans and community reporting. If fees are associated with filing, BellSouth and Level 3 will develop a cost sharing procedure. If BellSouth's permit or EPA identification number must be used, Level 3 must comply with all of BellSouth's permit conditions and environmental processes, including environmental "best management practices (BMP)" (see Section 2, below) and/or selection of BST disposition vendors and disposal sites.
- 1.8 Environmental and Safety Indemnification. BellSouth and Level 3 shall indemnify, defend and hold harmless the other party from and against any claims (including, without limitation, third-party claims for personal injury or death or real or personal property damage), judgments, damages, (including direct and indirect damages, and punitive damages), penalties, fines, forfeitures, costs, liabilities, interest and losses arising in connection with the violation or alleged violation of any Applicable Law or contractual obligation or the presence or alleged presence of contamination arising out of the acts or omissions of the indemnifying party, its agents, contractors, or employees concerning its operations at the Facility.

2. **CATEGORIES FOR CONSIDERATION OF ENVIRONMENTAL ISSUES**

When performing functions that fall under the following Environmental categories on BellSouth's Premises, Level 3 agrees to comply with the applicable sections of the current issue of BellSouth's Environmental and Safety Methods and Procedures (M&Ps), incorporated herein by this reference. Level 3 further agrees to cooperate with BellSouth to ensure that Level 3's employees, agents, and/or subcontractors are knowledgeable of and satisfy those provisions of BellSouth's Environmental M&Ps which apply to the specific Environmental function being performed by Level 3, its employees, agents and/or subcontractors.

The most current version of reference documentation must be requested from BellSouth.

EXHIBIT B**2. Categories for Consideration of Environmental Issues (cont.)**

ENVIRONMENTAL CATEGORIES	ENVIRONMENTAL ISSUES	ADDRESSED BY THE FOLLOWING DOCUMENTATION
Disposal of hazardous material or other regulated material (e.g., batteries, fluorescent tubes, solvents & cleaning materials)	Pollution liability insurance EVET approval of contractor	Std T&C 450 GU-BTEN-001BT, Chapter 4 Std T&C 660-3 GU-BTEN-001BT, Chapter 10
Emergency response	Hazmat/waste release/spill firesafety emergency	GU-BTEN-001BT, Chapter Building Emergency Operations Plan (EOP) (specific to Premises)
Contract labor/outsourcing for services with environmental implications to be performed on BellSouth Premises (e.g., disposition of hazardous material/waste; maintenance of storage tanks)	Performance of services in accordance with BST's environmental M&Ps Insurance	Std T&C 450 Std T&C 450-B (Contact E/S or your DEC/LDEC for copy of appropriate E/S M&Ps.) Std T&C 660
Transportation of hazardous material	Pollution liability insurance EVET approval of contractor	Std T&C 450 GU-BTEN-001BT, Chapter 4 Std T&C 660-3 GU-BTEN-001BT, Chapter 10
Maintenance/operations work which may produce a waste Other maintenance work	Protection of BST employees and equipment	Std T&C 450 GU-BTEN-001BT, Chapter 10 29CFR 1910.147 29CFR 1910 Subpart O
Janitorial services	All waste removal and disposal must conform to all applicable federal, state and local	P&SM Manager - Procurement GU-BTEN-001BT, Chapter 4, GU-BTEN-001BT, Chapter 3

	<p>regulations</p> <p>All HazMat & Waste Asbestos notification protection of BST employees and equipment</p>	BSP 010-170-001BS (Hazcom)
Manhole cleaning	<p>Pollution liability insurance</p> <p>Manhole entry requirements</p> <p>EVET approval of contractor</p>	<p>Std T&C 450</p> <p>Std T&C 660-3</p> <p>BSP 620-145-011PR</p> <p>Issue A, August 1996</p> <p>GU-BTEN-001BT, Chapter 10</p> <p>RL9706008BT</p>
Removing or disturbing building materials that may contain asbestos	Asbestos work practices	GU-BTEN-001BT, Chapter 3

3. DEFINITIONS

Generator. Under RCRA, the person whose act produces a Hazardous Waste, as defined in 40 CFR 261, or whose act first causes a Hazardous Waste to become subject to regulation. The Generator is legally responsible for the proper management and disposal of Hazardous Wastes in accordance with regulations.

Hazardous Chemical. As defined in the U.S. Occupational Safety and Health (OSHA) hazard communication standard (29 CFR 1910.1200), any chemical which is a health hazard or physical hazard.

Hazardous Waste. As defined in section 1004 of RCRA.

Imminent Danger. Any conditions or practices at a facility which are such that a danger exists which could reasonably be expected to cause immediate death or serious harm to people or immediate significant damage to the environment or natural resources.

Spill or Release. As defined in Section 101 of CERCLA.

4. ACRONYMS

DEC/LDEC - Department Environmental Coordinator/Local Department Environmental Coordinator

GU-BTEN-001BT - BellSouth Environmental Methods and Procedures

EVET - Environmental Vendor Evaluation Team

P&SM - Property & Services Management

Std. T&C - Standard Terms & Conditions

NESC - National Electrical Safety Codes

Attachment 5
Access to Numbers and Number Portability

TABLE OF CONTENTS

1. Non-Discriminatory Access To Telephone Numbers.....	<u>33</u>
2. Number Portability Permanent Solution	<u>33</u>
3. Service Provider Number Portability.....	<u>44</u>
4. SPNP Implementation	<u>44</u>
5. Transition To Permanent Number Portability	<u>77</u>
6. True-Up.....	<u>77</u>
7. Operational Support System (OSS) Rates.....	<u>88</u>
Rates.....	Exhibit A

ACCESS TO NUMBERS AND NUMBER PORTABILITY

1. Non-Discriminatory Access to Telephone Numbers

All the negotiated rates, terms and conditions set forth in this Attachment pertain to the provisioning of local number portability.

- 1.1 During the term of this Agreement, both Parties shall contact the North American Numbering Plan Administrator for the assignment of numbering resources. In order to be assigned a Central Office Code, each Party will be required to complete the Central Office Code (NXX) Assignment Request and Confirmation Form (Code Request Form) in accordance with Industry Numbering Committee's Central Office Code (NXX) Assignment Guidelines (INC 95-0407-008).
- 1.2 For the purposes of the resale of BellSouth's telecommunications services by Level 3, BellSouth will provide Level 3 with on line access to telephone numbers for reservation on a first come first served basis. Such reservations of telephone numbers, on a pre-ordering basis shall be for a period of ninety (90) days. Where there is a shortage of telephone numbers in a particular Common Language Location Identifier Code (CLLIC) both Parties may be forced to cancel their reservations of numbers. So long as BellSouth applies the shortage policy to itself and other CLECs on a non-discriminatory basis, Level 3 shall comply with BellSouth requests to release telephone number reservations.
- 1.3. Further, upon Level 3 request and for the purposes of the resale of BellSouth's telecommunications services by Level 3, BellSouth will reserve up to 100 telephone numbers per CLLIC for Level 3's sole use. Such telephone number reservations shall be transmitted to Level 3 via electronic file transfer. Such reservations shall be valid for ninety (90) days from the reservation date. Where there is a shortage of telephone numbers in a particular CLLIC, BellSouth shall use its best efforts to reserve for a ninety (90) day period a sufficient quantity for Level 3's reasonable need in that particular CLLIC. BellSouth will apply any policies to address such shortages on a non-discriminatory basis to itself, Level 3 and other CLECs.

2. Number Portability Permanent Solution

- 2.1 The FCC, the Commissions, and industry forums have developed and BellSouth is implementing a permanent approach to providing service provider number portability. Both Parties will implement, in accordance with the Act and applicable rules, a permanent approach as developed and approved by the Commission, the FCC and industry forums. Consistent with the requirements to move to Permanent Number Portability (PNP) as set forth in Section 5 of the Attachment and in FCC rules and orders, Interim Service Provider Number Portability (SPNP) may be available only until such permanent solution is implemented in a switch.

2.2 End User Line Charge. Recovery of charges associated with implementing PNP through a monthly charge assessed to end users has been authorized by the FCC. This end user line charge will be as filed in BellSouth's FCC Tariff No. 1 and will be billed to Level 3 where Level 3 is a subscriber to local switching or where Level 3 is a reseller of BellSouth telecommunications services. This charge will not be discounted.

3. Service Provider Number Portability

3.1 Definition. Until the industry-wide permanent solution is implemented in a switch, BellSouth shall provide Service Provider Number Portability ("SPNP"). SPNP is an interim service arrangement whereby an end user who switches subscription of his local exchange service from BellSouth to a CLEC, or vice versa, is permitted to retain the use of his existing assigned telephone number, provided that the end user remains at the same location for his local exchange service or changes locations and service providers but stays within the same serving wire center of his existing number.

3.2 Methods of Providing Number Portability. SPNP is available through either remote call forwarding or direct inward dialing trunks, at the election of Level 3. Remote call forwarding (SPNP-RCF) is an existing switch-based BellSouth service that redirects calls within the telephone network. Direct inward dialing trunks (SPNP-DID) allow calls to be routed over a dedicated facility to the Level 3 switch that serves the subscriber.

3.3 Signaling Requirements. SS7 Signaling is required for the provision of SPNP services. SPNP-DID is available from BellSouth on a per DS0, DS1, or DS3 basis. Where SPNP-DID is technically feasible and is provided on a DS1 or a DS3 basis, the applicable channelization rates are those specified in Section E6 in BellSouth's Intrastate Access Tariffs, incorporated herein by this reference. SPNP is available only for basic local exchange service.

3.4 Rates

Rates for SPNP are set out in Exhibit A to this Attachment.

4. SPNP Implementation

4.1 SPNP is available only where a CLEC or BellSouth is currently providing, or will begin providing concurrent with provision of SPNP, local exchange service to the affected end user. SPNP for a particular telephone number is available only from the central office originally providing local exchange service to the end user. SPNP for a particular assigned telephone number will be disconnected when any end user, Commission, BellSouth, or CLEC initiated activity (*e.g.*, a change in exchange boundaries) would normally result in a telephone number change had the end user retained his initial local exchange service.

4.2 SPNP-RCF, as contemplated by this Agreement, is a telecommunications service whereby a call dialed to an SPNP-RCF equipped telephone number is automatically

- forwarded to an assigned seven- or ten- digit telephone number within the local calling area as defined in BellSouth's General Subscriber Services Tariff. The forwarded-to number shall be specified by the CLEC or BellSouth, as appropriate. The forwarding Party will provide identification of the originating telephone number, via SS7 signaling, to the receiving Party. Identification of the originating telephone number to the SPNP-RCF end user cannot be guaranteed, however. SPNP-RCF provides a single call path for the forwarding of no more than one simultaneous call to the receiving Party's specified forwarded-to number.
- 4.3 SPNP-DID service, as contemplated by this Agreement, provides trunk side access to end office switches for direct inward dialing to the other Party's premises equipment from the telecommunications network to lines associated with the other Party's switching equipment and must be provided on all trunks in a group arranged for inward service. A SPNP-DID trunk termination charge, provided with SS7 Signaling only, applies for each trunk voice grade equivalent. In addition, direct facilities are required from the end office where a ported number resides to the end office serving the ported end user customer. The rates for a local channel and dedicated transport are as set forth in Exhibit C of Attachment 2. Transport mileage will be calculated as the airline distance between the end office where the number is ported and the Point of Interface ("POI") using the V&H coordinate method. SPNP-DID must be established with a minimum configuration of two channels and one unassigned telephone number per switch, per arrangement for control purposes. Transport facilities arranged for SPNP-DID may not be mixed with any other type of trunk group, with no outgoing calls placed over said facilities. SPNP-DID will be provided only where such facilities are available. Where SPNP-DID service is required from more than one wire center or from separate trunk groups within the same wire center, such service provided from each wire center or each trunk group within the same wire center shall be considered a separate service. Only customer-dialed sent-paid calls will be completed to the first number of a SPNP-DID number group; however, there are no restrictions on calls completed to other numbers of a SPNP-DID number group. Interface group arrangements provided for terminating the switched transport at the Party's terminal location are as set forth in of BellSouth's Intrastate Access Services Tariff, § E6.1.3.A as amended from time to time.
- 4.3.1 SPNP-DID Service requires ordering consecutive telephone numbers in blocks of twenty. To order non-consecutive telephone numbers or telephone numbers in less than blocks of twenty, the NBR process must be used. SS7 Signaling is required for the provision of either of these services.
- 4.4 The calling Party shall be responsible for payment of the applicable charges for sent-paid calls to the SPNP number. For collect, third-party, or other operator-assisted non-sent paid calls to the ported telephone number, BellSouth or the CLEC shall be responsible for the payment of charges under the same terms and conditions for which the end user would have been liable for those charges. Either Party may request that the other block collect and third party non-sent paid calls to the SPNP-assigned telephone number. If a Party does not request blocking, the other Party will provide

- itemized local usage detail for the billing of non-sent paid calls on the monthly bill of usage charges provided at the individual end user account level. The detail will include itemization of all billable usage. Each Party shall have the option of receiving this usage data on a daily basis via a data file transfer arrangement. This arrangement will utilize the existing industry uniform standard, known as EMI standards, for exchange of billing data. Files of usage data will be created daily for the optional service. Usage originated and recorded in the sending BellSouth RAO will be provided in unrated or rated format, depending on processing system. CLEC usage originated elsewhere and delivered via CMDS to the sending BellSouth RAO shall be provided in rated format.
- 4.5 Each Party shall be responsible for obtaining authorization from the end user for the handling of the disconnection of the end user's service, the provision of new local service and the provision of SPNP services. Each Party shall be responsible for coordinating the provision of service with the other to assure that its switch and other equipment and facilities are capable of accepting SPNP ported traffic. Neither Party shall be responsible for its inability to port calls to the other Party when such inability is caused by inadequate or insufficient equipment or facilities of the other Party. In the event that either Party determines in its reasonable judgment that the other Party will likely impair or is impairing, or interfering with any equipment, facility or service or any of its end users, that Party may either refuse to provide SPNP service or may terminate SPNP service to the other Party after providing thirty (30) days' prior written notice.
- 4.6 Each Party shall be responsible for providing an appropriate intercept announcement service for any telephone numbers subscribed to SPNP services for which it is not presently providing local exchange service or terminating to an end user. Where either Party chooses to disconnect or terminate any SPNP service, that Party shall be responsible for designating the preferred standard type of announcement to be provided.
- 4.7 Neither Party shall be responsible for adverse effects on any service, facility or equipment from the use of SPNP services. End-to-end transmission characteristics may vary depending on the distance and routing necessary to complete calls over SPNP facilities and the fact that another carrier is involved in the provisioning of service. Therefore, end-to-end transmission characteristics cannot be specified by either Party for such calls. Neither Party shall be responsible to the other if any necessary change in protection criteria or in any of the facilities, operation, or procedures of either renders any facilities provided by the other Party obsolete or renders necessary modification of the other Party's equipment.
- 4.8 For terminating IXC traffic ported to either Party which requires use of either Party's tandem switching, the tandem provider will bill the IXC tandem switching, the interconnection charge, if any, and a portion of the transport, and the other Party will bill the IXC local switching, the carrier common line and a portion of the transport. If the tandem provider is unable to provide the necessary access records to permit the

other Party to bill the IXC directly for terminating access to ported numbers, then the tandem provider will bill the IXC full terminating switched access charges at the tandem provider's rate and will compensate the other Party at the tandem Party's tariff rates via a process used by BellSouth to estimate the amount of ported switched access revenues due the other Party. If an intraLATA toll call is delivered, the delivering Party will pay terminating access rates to the other Party. This subsection does not apply in cases where SPNP-DID is utilized for number portability.

5. Transition to Permanent Number Portability

- 5.1 Once a PNP is implemented in a switch both Parties must withdraw their SPNP offerings for that switch to the extent required under the Act and effective and applicable FCC rules and orders. The transition from existing SPNP arrangements to PNP shall occur within one hundred twenty (120) days from the date PNP is implemented in the switch. Neither Party shall charge the other Party for conversion from SPNP to PNP. The Parties shall comply with any SPNP/PNP transition processes established by the FCC and State commissions and appropriate industry number portability work groups.
- 5.2 Notwithstanding the foregoing, the Parties acknowledge that the FCC has determined once LNP has been deployed pursuant to the FCC's orders, rules and regulations, that all local exchange carriers (LECs) have the duty to provide LNP consistent with the directives of the FCC in those orders and rules. Therefore, either Party may seek appropriate legal or regulatory relief concerning the transition from INP to LNP or other related issues.

6. True-up

This section applies only to Tennessee.

- 6.1 The interim prices for Network Elements and Other Services and Local Interconnection shall be subject to true-up according to the following procedures:

The interim prices shall be trued-up, either up or down, based on final prices determined either by further agreement between the Parties, or by a final order (including any appeals) of the Commission which final order meets the criteria of Section 6.3 below. The Parties shall implement the true-up by comparing the actual volumes and demand for each item, together with interim prices for each item, with the final prices determined for each item. Each Party shall keep its own records upon which the true-up can be based, and any final payment from one Party to the other shall be in an amount agreed upon by the Parties based on such records. In the event of any disagreement as between the records or the Parties regarding the amount of such true-up, the Parties agree that the body having jurisdiction over the matter shall be called upon to resolve such differences, or the Parties may mutually agree to submit the matter to the Dispute Resolution process in accordance with the provisions in the General Terms and Conditions and Attachment 1 of this Agreement.

- 6.2 The Parties may continue to negotiate toward final prices, but in the event that no such agreement is reached within nine (9) months, either Party may petition the Commission to resolve such disputes and to determine final prices for each item. Alternatively, upon mutual agreement, the Parties may submit the matter to the Dispute Resolution Process set forth in the General Terms and Conditions and Attachment 1 of the Agreement, so long as they file the resulting Agreement with the Commission as a “negotiated Agreement” under Section 252(e) of the Act.
- 6.3 A final order of this Commission that forms the basis of a true-up shall be the final order as to prices based on appropriate cost studies, or potentially may be a final order in any other Commission proceeding which meets the following criteria:
- (a) BellSouth and CLEC is entitled to be a full Party to the proceeding;
 - (b) It shall apply the provisions of the federal Telecommunications Act of 1996, including but not limited to Section 252(d)(1) (which contains pricing standards) and all then-effective implementing rules and regulations; and,
 - (c) (in the case of loops and ports only) It shall include as an issue the geographic deaveraging of network element prices, which deaveraged prices, if any are required by said final order, shall form the basis of any true-up.

7. Operational Support System (OSS) Rates

BellSouth has developed and made available the following mechanized systems by which Level 3 may submit LSRs electronically.

LENS	Local Exchange Navigation System
EDI	Electronic Data Interface
EDI-PC	Electronic Data Interface – Personal Computer
TAG	Telecommunications Access Gateway

LSRs submitted by means of one of these interactive interfaces will incur an OSS electronic ordering charge as specified in the table below. An individual LSR will be identified for billing purposes by its Purchase Order Number (PON). LSRs submitted by means other than one of these interactive interfaces (mail, fax, courier, etc.) will incur a manual order charge as specified in the table below:

OPERATIONAL SUPPORT SYSTEMS	AL, GA, LA, NC, MS, SC	FL, KY, TN
OSS LSR charge, per LSR received from the CLEC by one of the OSS interactive interfaces	\$3.50	\$3.50
	SOME C	SOME C
Incremental charge per LSR received from the CLEC by means other than one of the OSS interactive interfaces	See applicable rate element	\$19.99
		SOMAN

Note: In addition to the OSS charges, applicable discounted service order and related discounted charges apply per the tariff.

Denial/Restoral OSS Charge

In the event Level 3 provides a list of customers to be denied and restored, rather than an LSR, each location on the list will require a separate PON and, therefore will be billed as one LSR per location.

Cancellation OSS Charge

Level 3 will incur an OSS charge for an accepted LSR that is later canceled by Level 3.

Note: Supplements or clarifications to a previously billed LSR will not incur another OSS charge.

Network Elements and Other Services Manual Additive

The Commissions in Alabama, Georgia, Louisiana, Mississippi and South Carolina have ordered incremental manual non-recurring charges (NRC) for network elements and other services ordered by means other than one of the interactive interfaces. These ordered network elements and other services manual additive NRCs will apply in these states, rather than the charge per LSR submitted by means other than the OSS interactive interface, as set forth above.

Threshold Billing Plan

The Parties agree that Level 3 will incur the mechanized rate for all LSRs, both mechanized and manual, if the percentage of mechanized LSRs to total LSRs **meets or** exceeds the threshold percentages shown below:

Year	Ratio: Mechanized/Total LSRs
2000	80%
2001	90%

The threshold plan will be discontinued in 2002.

BellSouth will track the total LSR volume for each CLEC for each quarter. At the end of that time period, a Percent Electronic LSR calculation will be made for that quarter based on the LSR data tracked in the LCSC. If this percentage exceeds the threshold volume, all of that CLECs' future manual LSRs will be billed at the mechanized LSR rate. To allow time for obtaining and analyzing the data and updating the billing system, this billing change will take place on the first day of the second month following the end of the quarter (e.g. May 1 for 1Q, Aug 1 for 2Q, etc.). There will be no adjustments to the amount billed for previously billed LSRs.

BELLSOUTH/LEVEL 3 RATES
SERVICE PROVIDER
NUMBER PORTABILITY

DESCRIPTION	USOC	RATES BY STATE								
		AL	FL	GA	KY	LA	MS	NC	SC	TN
INTERIM SERVICE PROVIDER NUMBER PORTABILITY - RCF (1) (2)										
RCF, per number ported (Business Line), 10 paths	TNPBL	NA	NA	NA	NA	NA	NA	\$2.25	NA	NA
RCF, per number ported (Residence Line), 6 paths	TNPRL	NA	NA	NA	NA	NA	NA	\$1.15	NA	NA
RCF, per number ported (Business Line)	TNPBL	\$2.13	NA	\$2.03	NA	\$2.29	\$2.34	NA	\$2.17	\$1.50
NRC	TNPBL	\$0.65	NA	\$0.51	NA	\$0.49	\$0.6441	NA	\$0.7046	NA
NRC - Disconnect Charge	TNPBL	\$0.07	NA	NA	NA	\$0.05	\$0.0644	\$0.50	NA	NA
RCF, per number ported (Residence Line)	TNPRL	\$2.13	NA	\$2.03	NA	\$2.29	\$2.34	NA	\$2.17	\$1.25
NRC	TNPRL	\$0.65	NA	\$0.51	NA	\$0.49	\$0.6441	NA	\$0.7046	NA
NRC - Disconnect Charge	TNPRL	\$0.07	NA	NA	NA	\$0.05	\$0.0644	\$0.50	NA	NA
RCF, add'l capacity for simultaneous call forwarding, per additional path	N/A	\$0.32	NA	\$0.2836	NA	\$0.38	\$0.3838	NA	\$0.3854	\$0.50
RCF, per service order, per location	(++) Bus = TNPBD Res = TNPRD									
NRC - 1st	TNP++	\$1.44	NA	\$2.10	NA	\$2.02	\$2.84	None	\$1.37	\$25.00
NRC - Add'l	TNP++	\$1.44	NA	\$2.10	NA	\$2.02	\$2.84	None	\$1.37	\$25.00
NRC - Disconnect - 1st	TNP++	\$1.44	NA	NA	NA	\$2.01	\$2.84	NA	NA	NA
NRC - Disconnect - Add'l	TNP++	\$1.44	NA	NA	NA	\$2.01	\$2.84	NA	NA	NA
NRC - Incremental Charge - Manual Service Order - 1st	SOMAN	\$27.37	NA	NA	NA	\$18.14	\$25.52	NA	NA	NA
NRC - Incremental Charge - Manual Service Order - Add'l	SOMAN	\$27.37	NA	NA	NA	\$18.14	\$25.52	NA	NA	NA
NRC - Incremental Charge - Manual Service Order - Disconnect - 1st	SOMAN	\$17.77	NA	NA	NA	\$11.41	\$16.06	NA	\$44.70	NA
NRC - Incremental Charge - Manual Service Order - Disconnect - Add'l	SOMAN	\$17.77	NA	NA	NA	\$11.41	\$16.06	NA	\$44.70	NA
INTERIM SERVICE PROVIDER NUMBER PORTABILITY - DID										
DID per number ported, Residence - NRC	TNPDR	\$1.18	NA	\$0.93	NA	\$0.89	\$1.17	NA	\$2.25	NA
DID per number ported, Residence - NRC - Disconnect	TNPDR	\$1.18	NA	NA	NA	\$0.90	\$1.17	NA	NA	NA
DID per number ported, Business - NRC	TNPDB	\$1.18	NA	\$0.93	NA	\$0.89	\$1.17	NA	\$2.25	NA
DID per number ported, Business - NRC - Disconnect	TNPDB	\$1.18	NA	NA	NA	\$0.90	\$1.17	NA	NA	NA
DID per service order, per location										
NRC - 1st	TNPRD	\$1.44	NA	\$2.10	NA	\$2.02	\$2.84	NA	\$1.37	NA
NRC - Add'l	TNPRD	\$1.44	NA	\$2.10	NA	\$2.02	\$2.84	NA	\$1.37	NA
NRC - Disconnect - 1st	TNPRD	\$1.44	NA	NA	NA	\$2.01	\$2.84	NA	\$44.70	NA
NRC - Disconnect - Add'l	TNPRD	\$1.44	NA	NA	NA	\$2.01	\$2.84	NA	\$44.70	NA
NRC - Incremental Charge - Manual Service Order - 1st	SOMAN	\$27.37	NA	\$18.94	NA	\$18.14	\$25.52	NA	NA	NA
NRC - Incremental Charge - Manual Service Order - Add'l	SOMAN	\$27.37	NA	NA	NA	\$18.14	\$25.52	NA	NA	NA
NRC - Incremental Charge - Manual Service Order - Disconnect - 1st	SOMAN	\$17.77	NA	NA	NA	\$11.41	\$16.06	NA	NA	NA
NRC - Incremental Charge - Manual Service Order - Disconnect - Add'l	SOMAN	\$17.77	NA	NA	NA	\$11.41	\$16.06	NA	NA	NA
DID, per trunk termination, Initial	TNPT2	\$11.84	NA	\$10.73	NA	\$12.46	\$13.78	NA	\$13.16	NA
DID, per trunk termination, Initial - NRC	TNPT2	\$173.73	NA	\$135.47	NA	\$129.69	\$171.68	NA	\$218.03	NA
DID, per trunk termination, Initial - Disconnect	TNPT2	\$50.43	NA	NA	NA	\$37.85	\$49.86	NA	NA	NA
DID, per trunk termination, Subsequent	TNPT2	\$11.84	NA	\$10.73	NA	\$12.46	\$13.78	NA	\$13.16	NA
DID, per trunk termination, Subsequent - NRC	TNPT2	\$51.35	NA	\$39.53	NA	\$37.85	\$50.69	NA	\$73.63	NA
DID, per trunk termination, Subsequent - Disconnect	TNPT2	\$25.00	NA	NA	NA	\$18.75	\$24.71	NA	NA	NA

NOTES:

If no rate is identified in the contract, the rate for the specific service or function will be as set forth in applicable BellSouth tariff or as negotiated by the Parties upon request by either Party.

1 Until the FCC issues its order implementing a cost recovery mechanism for permanent number portability, the Company will track its costs of providing interim SPNP with sufficient detail to verify the costs. This will facilitate the Florida PSC's consideration of the recovery of these costs in Docket 950737-TP. (FL)

2 BellSouth and CLEC will each bear their own costs of providing remote call forwarding as an interim number portability option. (KY)

Attachment 6
Ordering and Provisioning

TABLE OF CONTENTS

1. Quality of Ordering And Provisioning	<u>33</u>
2. Access To Operational Support Systems	<u>33</u>
3. Miscellaneous Ordering And Provisioning Guidelines.....	<u>55</u>

ORDERING AND PROVISIONING

1. Quality of Ordering and Provisioning

All the negotiated terms and conditions set forth in this Attachment pertain to ordering and provisioning.

1.1 BellSouth shall provide ordering and provisioning services to Level 3 that are equal to the ordering and provisioning services BellSouth provides to itself, its affiliates or any other carrier. Detailed guidelines for ordering and provisioning are set forth in BellSouth's Local Interconnection and Facility Based Ordering Guide and Resale Ordering Guide, as appropriate, and as they are amended from time to time during this Agreement.

1.2 BellSouth will perform provisioning services during the following normal hours of operation:

Monday - Friday: 8:00AM - 5:00PM location time (excluding holidays)
(Resale/Network Element non coordinated, coordinated orders and order coordinated - Time Specific)

Saturday: 8:00 AM - 5:00 PM location time (excluding holidays)
(Resale/Network Element non coordinated orders)

Times are either Eastern or Central time based on the location of the work being performed.

1.3 All other Level 3 requests for provisioning and installation services are considered outside of the normal hours of operation and may be performed subject to the application of overtime charges set forth in BellSouth FCC Tariff No. 1.

2. Access to Operational Support Systems

2.1 BellSouth shall provide Level 3 access to several operations support systems. Access to these support systems is available through a variety of means, including electronic interfaces. BellSouth also provides the option of placing orders manually (e.g., via facsimile) through the Local Carrier Service Center. The operations support systems available are:

2.2 Pre-Ordering. BellSouth provides electronic access to the following pre-ordering functions: service address validation, telephone number selection, service and feature availability, due date information, and upon Commission approval of confidentiality protections, to customer record information. Access is provided through the Local

Exchange Navigation System (LENS) and the Telecommunications Access Gateway (TAG). Customer record information includes Customer Record Information but is not limited to, customer specific information in CRIS and RSAG.. In addition, Level 3 shall provide to BellSouth access to customer record information including electronic access where available. Otherwise, Level 3 shall provide paper copies of customer record information within a reasonable period of time upon request by BellSouth. Customer Record Information is equivalent to but not limited to the type of customer specific information contained in CRIS and RSAG. The parties agree not to view, copy, or otherwise obtain access to the customer record information of any customer without that customer's permission and further agrees that Level 3 and BellSouth will obtain access to customer record information only in strict compliance with applicable laws, rules, or regulations of the State in which the service is provided.

- 2.3 Service Ordering and Provisioning. BellSouth provides electronic options for the exchange of ordering and provisioning information. BellSouth provides an Electronic Data Interchange (EDI) arrangement for resale requests and certain network elements and other services. The EDI interface can be integrated with the TAG pre-ordering interface by Level 3. As an alternative to the EDI arrangement, BellSouth also provides ordering and provisioning capability through TAG that can be integrated with the TAG preordering capability by Level 3. Also, as an alternative, BellSouth provides integrated pre-ordering, ordering and provisioning capability through the LENS interface.
- 2.4 Service Trouble Reporting and Repair. Service trouble reporting and repair allows Level 3 to report and monitor service troubles and obtain repair services. BellSouth shall offer Level 3 service trouble reporting in a non-discriminatory manner that provides Level 3 the equivalent ability to report and monitor service troubles that BellSouth provides to itself, its affiliates and any other carrier. BellSouth also provides Level 3 an estimated time to repair, an appointment time or a commitment time, as appropriate, on trouble reports. BellSouth provides two options for electronic trouble reporting. For exchange services, BellSouth offers Level 3 access to the Trouble Analysis Facilitation Interface (TAFI). For individually designed services, BellSouth provides electronic trouble reporting through an electronic communications gateway. If the CLEC requests BellSouth to repair a trouble after normal working hours, the CLEC will be billed the appropriate overtime charges associated with this request at the rates set forth in BellSouth FCC Tariff No. 1.
- 2.5 Migration of Level 3 to New BellSouth Software Releases for National Standard Machine-to-Machine Electronic Interfaces. BellSouth will issue new software releases for new national standards, and machine-to-machine electronic interfaces as needed to improve operations and meet standards and regulatory requirements. When a new release of new national standards is implemented, BellSouth will continue to support both the new release (N) and the prior release (N-1). When BellSouth makes the next release (N+1), BellSouth will eliminate support for the (N-1) release and support the two newest releases (N and N+1). Thus, BellSouth will always support the two most current releases. BellSouth will issue documents to Level 3 advising Level 3 of the

release date of N+1 and the discontinue date of N-1 no less than thirty (30) days prior to the new release to allow Level 3 to make the necessary changes to their systems and operations to migrate to the newest release in a timely fashion.

- 2.6 Rates. Charges for Level 3's use of BellSouth's Operational Support Systems shall be as set forth in this Agreement.

3. Miscellaneous Ordering and Provisioning Guidelines

- 3.1 Pending Orders. To ensure the most efficient use of facilities and resources, orders placed in the hold or pending status by Level 3 will be held for a maximum of thirty (30) days from the date the order is placed on hold. After such time, if Level 3 wishes to reinstate an order, Level 3 may be required to submit a new service order.

- 3.2 Single Point of Contact. Level 3 will be the single point of contact with BellSouth for ordering activity for network elements and other services used by Level 3 to provide services to its end users, except that BellSouth may accept an order directly from another CLEC, or BellSouth, acting with authorization of the affected end user. If they have not already done so, Level 3 and BellSouth shall each execute a blanket letter of authorization with respect to customer orders. The Parties shall each be entitled to adopt their own internal processes for verification of customer authorization for orders, provided, however, that such processes shall comply with applicable state and federal law including, until superseded, the FCC guidelines and orders applicable to Presubscribed Interexchange Carrier (PIC) changes including Un-PIC. Pursuant to such an order, BellSouth may disconnect any network element associated with the service to be disconnected and being used by Level 3 to provide service to that end user and reuse such network elements or facilities to enable such other LEC to provide service to the end user. BellSouth will notify Level 3 that such an order has been processed, but will not be required to notify Level 3 in advance of such processing.

- 3.3 Use of Facilities. When a customer of a CLEC elects to discontinue service and transfer service to another local exchange carrier, including BellSouth, BellSouth shall have the right to reuse the facilities provided to CLEC by BellSouth for retail or resale service, loop and/or port for that customer. In addition, BellSouth may disconnect and reuse facilities when the facility is in a denied state and BellSouth has received an order to establish new service or transfer of service from a customer or a customer's CLEC at the same address served by the denied facility.

- 3.3.1 Upon receipt of a service order that results in a disconnect of a Level 3 customer that was served, in whole or in part, by use of BellSouth facilities or service, BellSouth will do the following:

- 3.3.1.1 Process disconnect and reconnect orders to provision the service which shall be due dated using the interval guidelines set forth in the Guides.

- 3.3.1.2 Reuse the serving facility for the retail, resale service, or network element at the same location.
- 3.3.1.3 Notify Level 3 within five (5) business days after the disconnect order is completed.
- 3.4 Contact Numbers. The Parties agree to provide one another with toll-free contact numbers for the purpose of ordering, provisioning and maintenance of services.
- 3.5 Subscription Functions. In cases where BellSouth performs subscription functions for an inter-exchange carrier (i.e. PIC and LPIC changes via Customer Account Record Exchange (CARE)), BellSouth will provide the affected inter-exchange carriers with the Operating Company Number (OCN) of the local provider for the purpose of obtaining end user billing account and other end user information required under subscription requirements.
- 3.6 Cancellation Charges. If Level 3 cancels an order for network elements or other services, BellSouth may recover, consistent with the methodology set forth in BellSouth FCC Tariff No. 1, any reasonable and demonstrable costs incurred by BellSouth in conjunction with the provisioning of that order prior to cancellation.

Attachment 7
Billing and Billing Accuracy Certification

TABLE OF CONTENTS

1. Payment and Billing Arrangements.....3

2. Billing Accuracy Certification..... 6

3. Billing Disputes 7

4. RAO Hosting..... 8

5. Optional Daily Usage File..... 11

6. Access Daily Usage File..... 14

7. Enhanced Optional Daily Usage File 17

Rates.....Exhibit A

BILLING AND BILLING ACCURACY CERTIFICATION

1. Payment and Billing Arrangements

All negotiated rates, terms and conditions set forth in this Attachment pertain to billing and billing accuracy certifications.

1.1 Billing. BellSouth agrees to provide billing through the Carrier Access Billing System (CABS) and through the Customer Records Information System (CRIS) depending on the particular service(s) that Level 3 requests. BellSouth will bill and record in accordance with this Agreement those charges Level 3 incurs as a result of Level 3 purchasing from BellSouth Network Elements and Other Services as set forth in this Agreement. BellSouth will format all bills in CBOS Standard or CLUB/EDI format, depending on the type of service ordered. For those services where standards have not yet been developed, BellSouth's billing format will change as necessary when standards are finalized by the industry forum. BellSouth will provide Level 3 thirty (30) days' prior notice of billing format changes.

1.1.1 For any service(s) BellSouth orders from Level 3, Level 3 shall bill BellSouth in CABS format.

1.1.2 If either Party requests multiple billing media or additional copies of bills, the Billing Party will provide these at a reasonable cost.

1.2 Master Account. After receiving certification as a local exchange company from the appropriate regulatory agency, where Level 3 has not already done so, it will provide the appropriate BellSouth account manager the necessary documentation to enable BellSouth to establish a master account for Local Interconnection, Network Elements and Other Services, and/or resold services. Such documentation shall include the Application for Master Account, proof of authority to provide telecommunications services, an Operating Company Number ("OCN") assigned by the National Exchange Carriers Association ("NECA"), Carrier Identification Code (CIC), Group Access Code (GAC), Access Customer Name and Address (ACNA) and a tax exemption certificate, if applicable. BellSouth will notify Level 3 within seven (7) business days of its receipt of documentation from Level 3 whether any additional information is required. BellSouth will use best efforts to provide Level 3 written confirmation within three (3) business days of establishing the Master Account that such account has been opened.

1.3 Payment Responsibility. Payment of all undisputed charges will be the responsibility of the billed Party. The billed Party shall make payment to the billing Party for all services billed where the charges for such services are undisputed. The billing Party is not responsible for payments not received by the billed Party from the billed Party's customer. The Billing Party will not become involved in billing disputes that may arise between the billed Party and its customer. Payments made to the billing Party on account will be credited to an accounts receivable master account and not to an end

user's account. For purposes of this Section 1, "undisputed amounts" shall mean amounts charged to the billed Party for which the billed Party has not submitted a good faith billing dispute in writing in accordance with this Attachment 7.

- 1.4 Payment Due. The payment will be due by the next bill date (i.e., same date in the following month as the bill date) and is payable in immediately available funds. Payment is considered to have been made when received.

If the payment due date falls on a Sunday or on a Holiday which is observed on a Monday, the payment due date shall be the first non-Holiday day following such Sunday or Holiday. If the payment due date falls on a Saturday or on a Holiday which is observed on Tuesday, Wednesday, Thursday, or Friday, the payment due date shall be the last non-Holiday day preceding such Saturday or Holiday. If payment is not received by the payment due date, a late payment penalty, as set forth in Section 1.7, below, shall apply.

- 1.5 Tax Exemption. Upon proof of tax exempt certification from a Party, the total amount billed to that Party will not include those taxes or fees for which the Party is exempt. Each Party will be solely responsible for the computation, tracking, reporting and payment of all taxes and like fees associated with the services provided to its end users.

- 1.6 Late Payment. If any portion of the payment is received by the billing Party after the payment due date as set forth preceding, or if any portion of the payment is received by the billing Party in funds that are not immediately available to the billing Party, then a late payment penalty shall be due to the billing Party. The late payment penalty shall be the undisputed portion of the payment not received by the payment due date times a late factor and will be applied on a per bill basis. The late factor for BellSouth shall be as set forth in Section A2 of the General Subscriber Services Tariff, Section B2 of the Private Line Service Tariff or Section E2 of the Intrastate Access Tariff, depending on the service provided. Level 3 will be charged a fee for all returned checks as set forth in Section A2 of the General Subscriber Services Tariff or in applicable state law. The late factor for Level 3 shall be as set forth in Level 3's effective intrastate access tariff as filed with the Commission.

- 1.7 Discontinuing Service to Level 3. The procedures for discontinuing service to Level 3 are as follows:

- 1.7.1 BellSouth reserves the right to suspend or terminate service upon thirty (30) days' prior written notice for nonpayment of undisputed amounts or upon seven (7) days' prior notice in the event of prohibited, unlawful or improper use of BellSouth facilities or service or any other violation or noncompliance by Level 3 of the rules and regulations contained in BellSouth's tariffs. If Level 3 should cure the alleged violation within the applicable notice time frame, BellSouth shall not suspend or terminate service.

- 1.7.2 If payment of undisputed amounts is not received by the bill day in the month after the original bill day, BellSouth may provide thirty (30) days' prior written notice to Level 3 that additional applications for service will be refused and that any pending orders for service will not be completed if payment is not received by the fifteenth day following the date of the notice. In addition, BellSouth may, at the same time, give thirty days notice to Level 3 to discontinue the provision of existing services to Level 3 if Level 3 does not cure within the thirty (30) day timeframe. If Level 3 should cure the alleged violation within the thirty (30) day time frame, BellSouth shall not suspend or terminate service or refuse additional applications for service. For purposes of this Section 1.7, "undisputed amounts" shall have the same meaning as set forth in Section 8.2.2 of Attachment 1.
- 1.7.3 In the case of such discontinuance, all billed charges, as well as applicable termination charges, shall become due.
- 1.7.4 If BellSouth does not discontinue the provision of the services involved on the date specified in the thirty days notice and Level 3's noncompliance continues, nothing contained herein shall preclude BellSouth's right to discontinue the provision of the services to Level 3 without further notice.
- 1.7.5 If payment of undisputed amounts is not received or satisfactory arrangements made for payment by the date given in the written notification, Level 3's services will be discontinued. Upon discontinuance of service on Level 3's account, service to the Level 3's end users will be denied. BellSouth will reestablish service at the request of the end user or Level 3 for BellSouth to reestablish service upon payment of the appropriate connection fee and subject to BellSouth's normal application procedures. Level 3 is solely responsible for notifying the end user of the proposed service disconnection. If within fifteen days after an end user's service has been denied and no arrangements to reestablish service have been made consistent with this subsection, the end user's service will be disconnected.
- 1.8 In order to safeguard its interest, BellSouth reserves the right to secure the account with a suitable form of security deposit, unless satisfactory credit has already been established. A CLEC may be deemed to have satisfactory credit if it rates a 5.0 or better on the Dun & Bradstreet Risk Assessment Monitor. In addition, in determining satisfactory credit, BellSouth evaluates factors such as payment history with suppliers, bank relationships, audited financial statement ratios, years in business, management history, number of liens, suits or judgments and pay history with BellSouth. To the extent not required as of the effective date of this Agreement, Level 3 shall not be required to furnish a security deposit or letter of credit to BellSouth absent an adverse material change in financial circumstances thereafter as determined in accordance with the foregoing factors. Such adverse material changes may be measured based upon changes that alone would not be deemed material but when considered in conjunction

with past adverse trends, including adverse trends occurring prior to the effective date hereof, constitute an adverse material change.

- 1.8.1 Such security deposit shall take the form of an irrevocable Letter of Credit or other forms of security acceptable to BellSouth. Any such security deposit may be held during the continuance of the service as security for the payment of any and all accounts accruing for the service.
- 1.8.2 If a security deposit is required, such security deposit shall be made prior to the inauguration of service.
- 1.8.3. Such security deposit may not exceed two months' estimated billing.
- 1.8.4. The fact that a security deposit has been made in no way relieves Level 3 from complying with BellSouth's regulations as to advance payments and the prompt payment of bills on presentation nor does it constitute a waiver or modification of the regular practices of BellSouth providing for the discontinuance of service for non-payment of any sums due BellSouth.
- 1.8.5. BellSouth reserves the right to increase the security deposit requirements when, in its reasonable judgment, material changes in Level 3's financial circumstances so warrant and/or gross monthly billing has increased significantly beyond the level initially used to determine the security deposit.
- 1.8.6 In the event that Level 3 defaults on its account, service to Level 3 will be terminated in accordance with Section 1.7 of this Attachment and any security deposits held will be applied to its account.
- 1.8.7 Interest on a security deposit shall accrue and be paid in accordance with the terms in the appropriate BellSouth tariff.
- 1.9 Rates. Rates for Optional Daily Usage File (ODUF), Enhanced Optional Daily Usage File (EODUF), Access Daily Usage File (ADUF), and Centralized Message Distribution Service (CMDS) are set out in Exhibit A to this Attachment.

2. Billing Accuracy Certification

- 2.1 Upon request, BellSouth and Level 3 will agree upon a billing quality assurance program for all billing elements covered in this Agreement that will eliminate the need for post-billing reconciliation. Appropriate terms for access to any BellSouth documents, systems, records, and procedures for the recording and billing of charges will be part of that program.

- 2.2 As part of the billing quality assurance program, BellSouth and Level 3 will develop standards, measurements, and performance requirements for a local billing measurements process. On a regular basis BellSouth will provide Level 3 with mutually agreed upon performance measurement data that substantiates the accuracy, reliability, and integrity of the billing process for local billing. In return, Level 3 will pay all undisputed bills received from BellSouth in full by the payment due date.
- 2.3 Local billing discrepancies will be addressed in an orderly manner via a mutually agreed upon billing exemption process.
- 2.3.1 Each Party agrees to notify the other Party upon identifying a billing discrepancy. The Parties shall endeavor to resolve any billing discrepancy within sixty (60) calendar days of the notification date. A mutually agreed upon escalation process will be established for resolving local billing discrepancies as part of the billing quality assurance program.
- 2.3.2 Closure of a specific billing period will occur by joint agreement of the Parties whereby the Parties agree that such billing period is closed to any further analysis and financial transactions except those resulting from regulatory mandates. Closure will take place within a mutually agreed upon time interval from the Bill Date. The month being closed represents those charges that were billed or should have been billed by the designated Bill Date.

3. Billing Disputes

- 3.1 Where the Parties have not agreed upon a billing quality assurance program, billing disputes shall be handled pursuant to the terms of this section.
- 3.1.1 Each Party agrees to notify the other Party in writing upon the discovery of a billing dispute. In the event of a billing dispute, the Parties will endeavor to resolve the dispute within sixty (60) calendar days of the notification date.
- 3.2 If a Party disputes a charge and does not pay such charge by the payment due date, or if a payment or any portion of a payment is received by either Party after the payment due date, or if a payment or any portion of a payment is received in funds which are not immediately available to the other Party, then a late payment penalty shall be assessed. In the event the billing dispute is ultimately resolved in favor of the disputing party, that Party shall not be liable for any of the disputed charges or any of the associated late payments. If the dispute is resolved against the disputing Party, the Party shall pay all disputed charges and all associated late payment charges no later than the second bill date after the resolution of the dispute. For bills rendered by either Party for payment, the late payment charge for both Parties shall be calculated based on the portion of the payment not received by the payment due date times the applicable late factor as identified in Section 1.6 of this Attachment. In no event, however, shall interest be assessed by either Party on any previously assessed late

payment charges. If a Party disputes charges but pays such charges and the dispute is resolved in favor of such Party, the other Party shall credit the bill of the disputing Party for the amount of the disputed charges plus interest at rates set forth in applicable tariffs no later than the second bill date after the resolution of the dispute.

3.3 For billing disputes, the Parties agree to follow the escalation process set forth in Section 12 of the General Terms and Conditions of this Agreement.

4. RAO Hosting

This section shall apply only to the extent that Level 3 selects BellSouth as its RAO host.

- 4.1 RAO Hosting, Calling Card and Third Number Settlement System (CATS) and Non-Intercompany Settlement System (NICS) services provided to Level 3 by BellSouth will be in accordance with the methods and practices regularly adopted and applied by BellSouth to its own operations during the term of this Agreement, including such revisions as may be made from time to time by BellSouth.
- 4.2 Level 3 shall furnish all relevant information required by BellSouth for the provision of RAO Hosting, CATS and NICS.
- 4.3 Compensation amounts, if applicable, will be billed by BellSouth to Level 3 on a monthly basis in arrears. Amounts due from one Party to the other (excluding adjustments) are payable within thirty (30) days of receipt of the billing statement.
- 4.4 Level 3 must have its own unique hosted RAO code. Requests for establishment of RAO status where BellSouth is the selected Centralized Message Distribution System (CMDS) interfacing host, require written notification from Level 3 to the BellSouth RAO Hosting coordinator at least eight (8) weeks prior to the proposed effective date. The proposed effective date will be mutually agreed upon between the Parties with consideration given to time necessary for the completion of required Telcordia (formerly BellCore) functions. BellSouth will request the assignment of an RAO code from its connecting contractor, currently Telcordia (formerly BellCore), on behalf of Level 3 and will coordinate all associated conversion activities.
- 4.5 BellSouth will receive messages from Level 3 that are to be processed by BellSouth, another LEC or CLEC in the BellSouth region or a LEC outside the BellSouth region.
- 4.6 BellSouth will perform invoice sequence checking, standard EMI format editing, and balancing of message data with the EMI trailer record counts on all data received from Level 3.
- 4.7 All data received from Level 3 that is to be processed or billed by another LEC or CLEC within the BellSouth region will be distributed to that LEC or CLEC in

- accordance with the Agreement(s) which may be in effect between BellSouth and the involved LEC or CLEC.
- 4.8 All data received from Level 3 that is to be placed on the CMDS network for distribution outside the BellSouth region will be handled in accordance with the agreement(s) which may be in effect between BellSouth and its connecting contractor (currently Telcordia (formerly BellCore)).
 - 4.9 BellSouth will receive messages from the CMDS network that are destined to be processed by Level 3 and will forward them to Level 3 on a daily basis.
 - 4.10 Transmission of message data between BellSouth and Level 3 will be via CONNECT:Direct.
 - 4.11 All messages and related data exchanged between BellSouth and Level 3 will be formatted in accordance with accepted industry standards for EMI formatted records and packed between appropriate EMI header and trailer records, also in accordance with accepted industry standards.
 - 4.12 Level 3 will ensure that the recorded message detail necessary to recreate files provided to BellSouth will be maintained for back-up purposes for a period of three (3) calendar months beyond the related message dates.
 - 4.13 Should it become necessary for Level 3 to send data to BellSouth more than sixty (60) days past the message date(s), Level 3 will notify BellSouth in advance of the transmission of the data. If there will be impacts outside the BellSouth region, BellSouth will work with its connecting contractor and Level 3 to notify all affected Parties.
 - 4.14 In the event that data to be exchanged between the two Parties should become lost or destroyed, both Parties will work together to determine the source of the problem. Once the cause of the problem has been jointly determined and the responsible Party (BellSouth or Level 3) identified and agreed to, the company responsible for creating the data (BellSouth or Level 3) will make every effort to have the affected data restored and retransmitted. If the data cannot be retrieved, the responsible Party will be liable to the other Party for any resulting lost revenue. Lost revenue may be a combination of revenues that could not be billed to the end users and associated access revenues. Both Parties will work together to estimate the revenue amount based upon historical data through a method mutually agreed upon. The resulting estimated revenue loss will be paid by the responsible Party to the other Party within three (3) calendar months of the date of problem resolution, or as mutually agreed upon by the Parties.
 - 4.15 Should an error be detected by the EMI format edits performed by BellSouth on data received from Level 3, the entire pack containing the affected data will not be

- processed by BellSouth. BellSouth will notify Level 3 of the error condition. Level 3 will correct the error(s) and will resend the entire pack to BellSouth for processing. In the event that an out-of-sequence condition occurs on subsequent packs, Level 3 will resend these packs to BellSouth after the pack containing the error has been successfully reprocessed by BellSouth.
- 4.16 In association with message distribution service, BellSouth will provide Level 3 with associated intercompany settlements reports (CATS and NICS) as appropriate.
- 4.17 In no case shall either Party be liable to the other for any direct or consequential damages incurred as a result of the obligations set out in this Agreement.
- 4.18 RAO Compensation
- 4.18.1 Rates for message distribution service provided by BellSouth for Level 3 are as set forth in Exhibit A to this Attachment.
- 4.18.2 Rates for data transmission associated with message distribution service are as set forth in Exhibit A to this Attachment .
- 4.18.3 Data circuits (private line or dial-up) will be required between BellSouth and Level 3 for the purpose of data transmission. Where a dedicated line is required, Level 3 will be responsible for ordering the circuit, overseeing its installation and coordinating the installation with BellSouth. Level 3 will also be responsible for any charges associated with this line. Equipment required on the BellSouth end to attach the line to the mainframe computer and to transmit successfully ongoing will be negotiated on a case by case basis. Where a dial-up facility is required, dial circuits will be installed in the BellSouth data center by BellSouth and the associated charges assessed to Level 3. Additionally, all message toll charges associated with the use of the dial circuit by Level 3 will be the responsibility of Level 3. Associated equipment on the BellSouth end, including a modem, will be negotiated on a case by case basis between the Parties.
- 4.18.4 All equipment, including modems and software, that is required on the Level 3 end for the purpose of data transmission will be the responsibility of Level 3.
- 4.19 Intercompany Settlements Messages
- 4.19.1 This Section addresses the settlement of revenues associated with traffic originated from or billed by Level 3 as a facilities based provider of local exchange telecommunications services outside the BellSouth region. Only traffic that originates in one Bell operating territory and bills in another Bell operating territory is included. Traffic that originates and bills within the same Bell operating territory will be settled on a local basis between Level 3 and the involved company(ies), unless that company is participating in NICS.

- 4.19.2 Both traffic that originates outside the BellSouth region by Level 3 and is billed within the BellSouth region, and traffic that originates within the BellSouth region and is billed outside the BellSouth region by Level 3, is covered by this Agreement (CATS). Also covered is traffic that either is originated by or billed by Level 3, involves a company other than Level 3, qualifies for inclusion in the CATS settlement, and is not originated or billed within the BellSouth region (NICS).
- 4.19.3 Once Level 3 is operating within the BellSouth territory, revenues associated with calls originated and billed within the BellSouth region will be settled via Telcordia (formerly BellCore)'s, its successor or assign, NICS system.
- 4.19.4 BellSouth will receive the monthly NICS reports from Telcordia (formerly BellCore), its successor or assign, on behalf of Level 3. BellSouth will distribute copies of these reports to Level 3 on a monthly basis.
- 4.19.5 BellSouth will receive the monthly Calling Card and Third Number Settlement System (CATS) reports from Telcordia (formerly BellCore), its successor or assign, on behalf of Level 3. BellSouth will distribute copies of these reports to Level 3 on a monthly basis.
- 4.19.6 BellSouth will collect the revenue earned by Level 3 from the Bell operating company in whose territory the messages are billed (CATS), less a per message billing and collection fee of five cents (\$0.05), on behalf of Level 3. BellSouth will remit the revenue billed by Level 3 to the Bell operating company in whose territory the messages originated, less a per message billing and collection fee of five cents (\$0.05), on behalf on Level 3. These two amounts will be netted together by BellSouth and the resulting charge or credit issued to Level 3 via a monthly Carrier Access Billing System (CABS) miscellaneous bill.
- 4.19.7 BellSouth will collect the revenue earned by Level 3 within the BellSouth territory from another CLEC also within the BellSouth territory (NICS) where the messages are billed, less a per message billing and collection fee of five cents (\$0.05), on behalf of Level 3. BellSouth will remit the revenue billed by Level 3 within the BellSouth region to the CLEC also within the BellSouth region, where the messages originated, less a per message billing and collection fee of five cents (\$0.05). These two amounts will be netted together by BellSouth and the resulting charge or credit issued to Level 3 via a monthly Carrier Access Billing System (CABS) miscellaneous bill.

BellSouth and Level 3 agree that monthly netted amounts of less than fifty dollars (\$50.00) will not be settled.

5. Optional Daily Usage File

- 5.1 Upon written request from Level 3, BellSouth will provide the Optional Daily Usage File (ODUF) service to Level 3 pursuant to the terms and conditions set forth in this section.
- 5.2 Level 3 shall furnish all relevant information required by BellSouth for the provision of the Optional Daily Usage File.
- 5.3 The Optional Daily Usage Feed will contain billable messages that were carried over the BellSouth Network and processed in the BellSouth Billing System, but billed to a Level 3 customer.

Charges for delivery of the Optional Daily Usage File will appear on Level 3's monthly bills. The charges are as set forth in Exhibit A to this Attachment.

- 5.4 The Optional Daily Usage Feed will contain both rated and unrated messages. All messages will be in the standard Alliance for Telecommunications Industry Solutions (ATIS) EMI record format.
- 5.5 Messages that error in the billing system of Level 3 will be the responsibility of Level 3. If, however, Level 3 should encounter significant volumes of errored messages that prevent processing by Level 3 within its systems, BellSouth will work with Level 3 to determine the source of the errors and the appropriate resolution.
- 5.6 The following specifications shall apply to the Optional Daily Usage Feed.
- 5.6.1 Usage To Be Transmitted
- 5.6.1.1 The following messages recorded by BellSouth will be transmitted to Level 3:
- Message recording for per use/per activation type services (examples: Three Way Calling, Verify, Interrupt, Call Return, ETC.)
 - Measured billable Local
 - Directory Assistance messages
 - IntraLATA Toll
 - WATS & 800 Service

 - N11
 - Information Service Provider Messages
 - Operator Services Messages
 - Operator Services Message Attempted Calls (Network Element only)
 - Credit/Cancel Records
 - Usage for Voice Mail Message Service

- 5.6.1.2 Rated Incollects (originated in BellSouth and from other companies) can also be on Optional Daily Usage File. Rated Incollects will be intermingled with BellSouth recorded rated and unrated usage. Rated Incollects will not be packed separately.
- 5.6.1.3 BellSouth will perform duplicate record checks on records processed to Optional Daily Usage File. Any duplicate messages detected will be deleted and not sent to Level 3.
- 5.6.1.4 In the event that Level 3 detects a duplicate on Optional Daily Usage File they receive from BellSouth, Level 3 will drop the duplicate message (Level 3 will not return the duplicate to BellSouth).
- 5.6.2 Physical File Characteristics
 - 5.6.2.1 The Optional Daily Usage File will be distributed to Level 3 via an agreed medium with CONNECT:Direct being the preferred transport method. The Daily Usage Feed will be a variable block format (2476) with an LRECL of 2472. The data on the Daily Usage Feed will be in a non-compacted EMI format (175 byte format plus modules). It will be created on a daily basis (Monday through Friday except holidays). Details such as dataset name and delivery schedule will be addressed during negotiations of the distribution medium. There will be a maximum of one dataset per workday per OCN.
 - 5.6.2.2 Data circuits (private line or dial-up) may be required between BellSouth and Level 3 for the purpose of data transmission. Where a dedicated line is required, Level 3 will be responsible for ordering the circuit, overseeing its installation and coordinating the installation with BellSouth. Level 3 will also be responsible for any charges associated with this line. Equipment required on the BellSouth end to attach the line to the mainframe computer and to transmit successfully ongoing will be negotiated on a case by case basis. Where a dial-up facility is required, dial circuits will be installed in the BellSouth data center by BellSouth and the associated charges assessed to Level 3. Additionally, all message toll charges associated with the use of the dial circuit by Level 3 will be the responsibility of Level 3. Associated equipment on the BellSouth end, including a modem, will be negotiated on a case by case basis between the Parties. All equipment, including modems and software, that is required on Level 3 end for the purpose of data transmission will be the responsibility of Level 3.
- 5.6.3 Packing Specifications
 - 5.6.3.1 A pack will contain a minimum of one message record or a maximum of 99,999 message records plus a pack header record and a pack trailer record. One transmission can contain a maximum of 99 packs and a minimum of one pack.
 - 5.6.3.2 The OCN, From RAO, and Invoice Number will control the invoice sequencing. The From RAO will be used to identify to Level 3 which BellSouth RAO that is sending

the message. BellSouth and Level 3 will use the invoice sequencing to control data exchange. BellSouth will be notified of sequence failures identified by Level 3 and resend the data as appropriate.

The data will be packed using ATIS EMI records.

5.6.4 Pack Rejection

- 5.6.4.1 Level 3 will notify BellSouth within one business day of rejected packs (via the mutually agreed medium). Packs could be rejected because of pack sequencing discrepancies or a critical edit failure on the Pack Header or Pack Trailer records (i.e. out-of-balance condition on grand totals, invalid data populated). Standard ATIS EMI Error Codes will be used. Level 3 will not be required to return the actual rejected data to BellSouth. Rejected packs will be corrected and retransmitted to Level 3 by BellSouth.

5.6.5 Control Data

Level 3 will send one confirmation record per pack that is received from BellSouth. This confirmation record will indicate Level 3 received the pack and the acceptance or rejection of the pack. Pack Status Code(s) will be populated using standard ATIS EMI error codes for packs that were rejected by Level 3 for reasons stated in the above section.

5.6.6 Testing

- 5.6.6.1 Upon request from Level 3, BellSouth shall send test files to Level 3 for the Optional Daily Usage File. The Parties agree to review and discuss the file's content and/or format. For testing of usage results, BellSouth shall request that Level 3 set up a production (LIVE) file. The live test may consist of Level 3's employees making test calls for the types of services Level 3 requests on the Optional Daily Usage File. These test calls are logged by Level 3, and the logs are provided to BellSouth. These logs will be used to verify the files. Testing will be completed within 30 calendar days from the date on which the initial test file was sent.

6. Access Daily Usage File

- 6.1. Upon written request from Level 3, BellSouth will provide the Access Daily Usage File (ADUF) service to Level 3 pursuant to the terms and conditions set forth in this section.
- 6.2. The Level 3 shall furnish all relevant information required by BellSouth for the provision of the Access Daily Usage File.

6.3 The Access Daily Usage Feed will contain access messages associated with a port that Level 3 has purchased from BellSouth

6.4 Charges for delivery of the Access Daily Usage File will appear on the Level 3s' monthly bills. The charges are as set forth in Exhibit A to this Attachment. All messages will be in the standard Alliance for Telecommunications Industry Solutions (ATIS) EMI record format.

6.5 Messages that error in the billing system of the Level 3 will be the responsibility of the Level 3. If, however, the Level 3 should encounter significant volumes of errored messages that prevent processing by the Level 3 within its systems, BellSouth will work with the Level 3 to determine the source of the errors and the appropriate resolution.

6.6 Usage To Be Transmitted

6.6.1 The following messages recorded by BellSouth will be transmitted to Level 3:

Interstate and intrastate access records associated with a port.

Undetermined jurisdiction access records associated with a port.

6.6.2 When Level 3 purchases Network Element ports from BellSouth and calls are made using these ports, BellSouth will handle the calls as follows:

Originating from Network Element and carried by Interexchange Carrier:

BellSouth will bill network element to CLEC and send access record to the CLEC via ADUF

Originating from network element and carried by BellSouth (Level 3 is BellSouth's toll customer):

BellSouth will bill resale toll rates to Level 3 and send toll record for the end user toll billing purposes via ODUF (Optional Daily Usage File). Access record will be sent to Level 3 via ADUF.

Terminating on network element and carried by Interexchange Carrier:

BellSouth will bill network element to Level 3 and send access record to Level 3.

Terminating on network element and carried by BellSouth:

BellSouth will bill network element to Level 3 and send access record to Level 3.

6.6.3 BellSouth will perform duplicate record checks on records processed to the Access Daily Usage File. Any duplicate messages detected will be dropped and not sent to Level 3.

6.6.4 In the event that Level 3 detects a duplicate on the Access Daily Usage File they receive from BellSouth, Level 3 will drop the duplicate message (Level 3 will not return the duplicate to BellSouth.)

6.6.5 Physical File Characteristics

6.6.5.1 The Access Daily Usage File will be distributed to Level 3 via an agreed medium with CONNECT:Direct being the preferred transport method. The Daily Usage Feed will be a fixed block format (2476) with an LRECL of 2472. The data on the Daily Usage Feed will be in a non-compacted EMI format (210 byte format plus modules). It will be created on a daily basis (Monday through Friday except holidays). Details such as dataset name and delivery schedule will be addressed during negotiations of the distribution medium. There will be a maximum of one dataset per workday per OCN.

6.6.5.2 Data circuits (private line or dial-up) may be required between BellSouth and Level 3 for the purpose of data transmission. Where a dedicated line is required, Level 3 will be responsible for ordering the circuit, overseeing its installation and coordinating the installation with BellSouth. Level 3 will also be responsible for any charges associated with this line. Equipment required on the BellSouth end to attach the line to the mainframe computer and to transmit successfully ongoing will be negotiated on a case by case basis. Where a dial-up facility is required, dial circuits will be installed in the BellSouth data center by BellSouth and the associated charges assessed to Level 3. Additionally, all message toll charges associated with the use of the dial circuit by Level 3 will be the responsibility of Level 3. Associated equipment on the BellSouth end, including a modem, will be negotiated on a case by case basis between the Parties. All equipment, including modems and software, that is required on Level 3 end for the purpose of data transmission will be the responsibility of Level 3.

6.6.6 Packing Specifications

6.6.6.1 A pack will contain a minimum of one message record or a maximum of 99,999 message records plus a pack header record and a pack trailer record. One transmission can contain a maximum of 99 packs and a minimum of one pack.

6.6.6.2 The OCN, From RAO, and Invoice Number will control the invoice sequencing. The From RAO will be used to identify to Level 3 which BellSouth RAO that is sending the message. BellSouth and Level 3 will use the invoice sequencing to control data exchange. BellSouth will be notified of sequence failures identified by Level 3 and resend the data as appropriate.

The data will be packed using ATIS EMI records.

6.6.7 Pack Rejection

6.6.7.1 Level 3 will notify BellSouth within one business day of rejected packs (via the mutually agreed medium). Packs could be rejected because of pack sequencing discrepancies or a critical edit failure on the Pack Header or Pack Trailer records (i.e. out-of-balance condition on grand totals, invalid data populated). Standard ATIS EMI Error Codes will be used. Level 3 will not be required to return the actual rejected data to BellSouth. Rejected packs will be corrected and retransmitted to Level 3 by BellSouth.

6.6.8 Control Data

Level 3 will send one confirmation record per pack that is received from BellSouth. This confirmation record will indicate Level 3 received the pack and the acceptance or rejection of the pack. Pack Status Code(s) will be populated using standard ATIS EMI error codes for packs that were rejected by Level 3 for reasons stated in the above section.

6.6.9 Testing

6.6.9.1 Upon request from Level 3, BellSouth shall send test files to Level 3 for the Access Daily Usage File. Testing shall consist of actual calls made from live accounts. A call log shall be supplied along with test request information. The Parties agree to review and discuss the file's content and/or format.

7. Enhanced Optional Daily Usage File

7.1 Upon written request from Level 3, BellSouth will provide the Enhanced Optional Daily Usage File (EODUF) service to Level 3 pursuant to the terms and conditions set forth in this section. EODUF will only be sent to existing ODUF subscribers who request the EODUF option.

7.2 Level 3 shall furnish all relevant information required by BellSouth for the provision of the Enhanced Optional Daily Usage File.

7.3 The Enhanced Optional Daily Usage File (EODUF) will provide usage data for local calls originating from resold Flat Rate Business and Residential Lines.

Charges for delivery of the Enhanced Optional Daily Usage File will appear on Level 3s' monthly bills. The charges are as set forth in Exhibit A to this Attachment.

- 7.4 All messages will be in the standard Alliance for Telecommunications Industry Solutions (ATIS) EMI record format.
- 7.5 Messages that error in the billing system of Level 3 will be the responsibility of Level 3. If, however, Level 3 should encounter significant volumes of errored messages that prevent processing by Level 3 within its systems, BellSouth will work with Level 3 to determine the source of the errors and the appropriate resolution.

7.6 The following specifications shall apply to the Optional Daily Usage Feed.

7.6.1 Usage To Be Transmitted

- 7.6.1.1 The following messages recorded by BellSouth will be transmitted to Level 3:

Customer usage data for flat rated local call originating from CLEC end user lines (1FB or 1FR). The EODUF record for flat rate messages will include:

- Date of Call
- From Number
- To Number
- Connect Time
- Conversation Time
- Method of Recording
- From RAO
- Rate Class
- Message Type
- Billing Indicators
- Bill to Number

- 7.6.1.2 BellSouth will perform duplicate record checks on EODUF records processed to Optional Daily Usage File. Any duplicate messages detected will be deleted and not sent to Level 3.
- 7.6.1.3 In the event that Level 3 detects a duplicate on Enhanced Optional Daily Usage File they receive from BellSouth, Level 3 will drop the duplicate message (Level 3 will not return the duplicate to BellSouth).

7.6.2 Physical File Characteristics

- 7.6.2.1 The Enhanced Optional Daily Usage Feed will be distributed to Level 3 over their existing Optional Daily Usage File (ODUF) feed. The EODUF messages will be intermingled among Level 3's Optional Daily Usage File (ODUF) messages. The EODUF will be a variable block format (2476) with an LRECL of 2472. The data on

the EODUF will be in a non-compacted EMI format (175 byte format plus modules). It will be created on a daily basis (Monday through Friday except holidays).

- 7.6.2.2 Data circuits (private line or dial-up) may be required between BellSouth and Level 3 for the purpose of data transmission. Where a dedicated line is required, Level 3 will be responsible for ordering the circuit, overseeing its installation and coordinating the installation with BellSouth. Level 3 will also be responsible for any charges associated with this line. Equipment required on the BellSouth end to attach the line to the mainframe computer and to transmit successfully ongoing will be negotiated on a case by case basis. Where a dial-up facility is required, dial circuits will be installed in the BellSouth data center by BellSouth and the associated charges assessed to Level 3. Additionally, all message toll charges associated with the use of the dial circuit by Level 3 will be the responsibility of Level 3. Associated equipment on the BellSouth end, including a modem, will be negotiated on a case by case basis between the Parties. All equipment, including modems and software, that is required on Level 3 end for the purpose of data transmission will be the responsibility of Level 3.

7.6.3 Packing Specifications

- 7.6.3.1 A pack will contain a minimum of one message record or a maximum of 99,999 message records plus a pack header record and a pack trailer record. One transmission can contain a maximum of 99 packs and a minimum of one pack.
- 7.6.3.2 The Operating Company Number (OCN), From Revenue Accounting Office (RAO), and Invoice Number will control the invoice sequencing. The From RAO will be used to identify to Level 3 which BellSouth RAO that is sending the message. BellSouth and Level 3 will use the invoice sequencing to control data exchange. BellSouth will be notified of sequence failures identified by Level 3 and resend the data as appropriate.

The data will be packed using ATIS EMI records.

BELLSOUTH/LEVEL 3 RATES
 ODUF/EODUF/ADUF/CMDS

DESCRIPTION	USOC	RATES BY STATE								
		AL	FL	GA	KY	LA	MS	NC	SC	TN
ODUF/EODUF/ADUF/CMDS										
ODUF: Recording, per message	N/A	\$0.0002	\$0.008	\$0.008	\$0.0008611	\$0.00019	\$0.0001179	\$0.008	\$0.0002862	\$0.008
ODUF: Message Processing, per message	N/A	\$0.0033	\$0.004	\$0.004	\$0.0032357	\$0.0024	\$0.0032089	\$0.004	\$0.0032344	\$0.004
EODUF: Message Processing, per message	N/A	\$0.004	\$0.004	\$0.004	\$0.004	\$0.004	\$0.004	\$0.004	\$0.004	\$0.004
ADUF: Message Processing, per message	N/A	\$0.004	\$0.004	\$0.004	\$0.004	\$0.004	\$0.004	\$0.004	\$0.004	\$0.004
CMDS: Message Processing, per message	N/A	\$0.004	\$0.004	\$0.004	\$0.004	\$0.004	\$0.004	\$0.004	\$0.004	\$0.004
ODUF: Message Processing, per magnetic tape provisioned	N/A	\$55.19	\$54.95	\$54.95	\$55.68	\$47.30	\$54.62	\$54.95	\$54.72	\$54.95
EODUF: Message Processing, per magnetic tape provisioned	N/A	\$47.30	\$47.30	\$47.30	\$47.30	\$47.30	\$47.30	\$47.30	\$47.30	\$47.30
ADUF: Message Processing, per magnetic tape provisioned	N/A	\$54.95	\$54.95	\$54.95	\$54.95	\$54.95	\$54.95	\$54.95	\$54.95	\$54.95
ODUF: Data Transmission (CONNECT:DIRECT), per message	N/A	\$0.00004	\$0.001	\$0.001	\$0.0000365	\$0.00003	\$0.0000354	\$0.001	\$0.0000357	\$0.001
EODUF: Data Transmission (CONNECT:DIRECT), per message	N/A	\$0.0000364	\$0.0000364	\$0.0000364	\$0.0000364	\$0.0000364	\$0.0000364	\$0.0000364	\$0.0000364	\$0.0000364
ADUF: Data Transmission (CONNECT:DIRECT), per message	N/A	\$0.001	\$0.001	\$0.001	\$0.001	\$0.001	\$0.001	\$0.001	\$0.001	\$0.001
CMDS: Data Transmission (CONNECT:DIRECT), per message	N/A	\$0.001	\$0.001	\$0.001	\$0.001	\$0.001	\$0.001	\$0.001	\$0.001	\$0.001
NOTES:										
If no rate is identified in the contract, the rate for the specific service or function will be as set forth in applicable BellSouth tariff or as negotiated by the parties upon request by either party.										

Attachment 8

Rights-of-Way, Conduits and Pole Attachments

Rights-of-Way, Conduits and Pole Attachments

BellSouth will provide nondiscriminatory access to any pole, duct, conduit, or right-of-way owned or controlled by BellSouth pursuant to 47 U.S.C. § 224, as amended by the Act, pursuant to terms and conditions of a license agreement subsequently negotiated with BellSouth's Competitive Structure Provisioning Center.

Attachment 9
Performance Measurements

TABLE OF CONTENTS

Service Performance Measurements And Enforcement Mechanisms..... 3

1. Scope 3

2. Reporting 3

3. Modifications to Measurements..... 3

4. Enforcement Mechanisms..... 4

EXHIBIT A 10

EXHIBIT B..... 77

EXHIBIT C 83

EXHIBIT D 99

EXHIBIT E.....105

Service Performance Measurements And Enforcement Mechanisms

1. Scope

This Attachment includes Enforcement Measurements with corresponding Enforcement Mechanisms applicable to this Agreement.

2. Reporting

2.1 In providing services pursuant to this Agreement, BellSouth will report its performance to Level 3 in accordance with BellSouth's Service Quality Measurements, which are contained in this Attachment as Exhibit A and in accordance with BellSouth's Enforcement Measurements, which are contained in this Attachment as Exhibit B.

2.2 BellSouth will make performance reports available to Level 3 on a monthly basis. The reports will contain information collected in each performance category and will be available to Level 3 through some electronic medium to be determined by BellSouth. BellSouth will also provide electronic access to the raw data underlying the performance measurements. Within thirty (30) days of execution of this Agreement, BellSouth will provide a detailed session of instruction to Level 3 regarding access to the reports and to the raw data as well as the nature of the format of the data provided.

3. Modifications to Measurements

3.1 Service Quality Measurements

3.1.1 BellSouth will update the Service Quality Measurements contained in Exhibit A of this Attachment each calendar quarter. BellSouth will not delete any Service Quality Measurement without prior written consent of Level 3. Level 3 may provide input to BellSouth regarding any suggested additions, deletions or other modifications to the Service Quality Measurements. BellSouth will provide notice of all changes to the Service Quality Measurements via BellSouth's internet website.

3.1.2 Notwithstanding the foregoing, BellSouth may, from time to time, be ordered by a regulatory or judicial body to modify or amend the Service Quality Measurements. BellSouth will make all such changes to the Service Quality Measurements pursuant to Section 15 of the General Terms and Conditions of this Agreement, incorporated herein by reference.

3.1.3 Notwithstanding any other provision of this Agreement, in the event

a dispute arises regarding the modification or amendment of the Service Quality Measurements, the parties will refer the dispute to the Commission.

3.2 Enforcement Measurements and Statistical Test

3.2.1 In order for BellSouth to accurately administer the Enforcement Measurements contained in Exhibit B of this Attachment, the Enforcement Measurements shall be modified or amended only if BellSouth determines such modification or amendment is necessary. However, BellSouth will not delete any Enforcement Measurement without prior written consent of Level 3. BellSouth will notify Level 3 of any such modification or amendment to the Enforcement Measurements via BellSouth's internet website.

3.2.2 Notwithstanding the foregoing, BellSouth may, from time to time, be ordered by a regulatory or judicial body to modify or amend the Enforcement Measurements and/or Statistical Test. BellSouth will make all such changes to the Enforcement Measurements and/or Statistical Test pursuant to Section 15 of the General Terms and Conditions of this Agreement, incorporated herein by reference.

3.2.3 Notwithstanding any other provision of this Agreement, in the event a dispute arises regarding the modification or amendment of the Enforcement Measurements and/or Statistical Test, the parties will refer the dispute to the Commission.

4. Enforcement Mechanisms

4.1 Purpose

This section establishes meaningful and significant enforcement mechanisms voluntarily provided by BellSouth to verify and maintain compliance between BellSouth and Level 3's operations as well as to maintain access to Operational Support System (OSS) functions. This section provides the terms and conditions for such self-effectuating enforcement mechanisms.

4.2 Effective Date

The enforcement mechanisms set forth in this section shall only become effective upon the earlier of the following: (i) an effective FCC order, which has not been stayed, authorizing BellSouth to provide interLATA telecommunications services under section 271 of the Act within a particular state and shall only apply to BellSouth's performance in any state in which the FCC has granted BellSouth interLATA authority; or (ii)

an effective Commission order in a generic proceeding or a proceeding specific to Level 3 requiring BellSouth to implement such enforcement mechanisms in that jurisdiction.

4.3 Definitions

4.3.1 Enforcement Measurement Elements means the performance measurements set forth in Exhibit B, attached hereto and incorporated herein by this reference.

4.3.2 Enforcement Measurement Benchmark means a competitive level of performance negotiated by BellSouth used to compare the performance of BellSouth and Level 3 where no analogous process, product or service is feasible. See Exhibit B.

4.3.3 Enforcement Measurement Compliance means comparing performance levels provided to BellSouth retail customers with performance levels provided by BellSouth to the CLEC customer, as set forth in Exhibit C, attached hereto and incorporated herein by this reference.

4.3.4 Test Statistic and Balancing Critical Value is the means by which enforcement will be determine using statistically valid equations. See Exhibit C.

4.3.5 Cell is the point (below the wire center level) at which like-to-like comparisons are made. For example, all BellSouth retail POTS services, for residential customers, requiring a dispatch in a particular wire center, at a particular point in time will be compared directly to Level 3 resold services for residential customers, requiring a dispatch, in the same wire center, at a particular point in time. When determining compliance, these cells can have a positive or negative value. See Exhibit C.

4.3.6 Affected Volume means that proportion of the total Level 3 volume or CLEC Aggregate volume for which remedies will be paid.

4.3.7 Parity Gap refers to the incremental departure from a compliant-level of service. (See Exhibit D). This is also referred to as “diff” in the Statistical paper (See Exhibit C).

4.3.8 Tier-1 Enforcement Mechanisms means self-executing liquidated damages paid directly to Level 3 when BellSouth delivers non-compliant performance of any one of the Enforcement Measurement Elements for any month as calculated by BellSouth.

4.3.9 Tier-2 Enforcement Mechanisms means Assessments paid directly to a state Public Service Commission (“Commission”) or its designee. Tier 2

Enforcement Mechanisms are triggered by three consecutive monthly failures in a quarter in which BellSouth performance is out of compliance or does not meet the benchmarks for the aggregate of all CLEC data as calculated by BellSouth for a particular Enforcement Measurement Element.

- 4.3.10 Tier-3 Enforcement Mechanisms means the voluntary suspension of additional marketing and sales of long distance services triggered by excessive repeat failures of those specific submeasures as defined in Exhibit D attached hereto and incorporated herein by this reference.
- 4.4 Application
 - 4.4.1 The application of the Tier-1, Tier-2, and Tier-3 Enforcement Mechanisms does not foreclose other non-contractual legal and regulatory claims and remedies available to Level 3.
 - 4.4.2 Proof of damages resulting from BellSouth's failure to maintain Enforcement Measurement Compliance would be difficult to ascertain and, therefore, liquidated damages are a reasonable approximation of any contractual damage. Liquidated damages under this provision are not intended to be a penalty.
- 4.5 Methodology
 - 4.5.1 Tier-1 Enforcement Mechanisms will be triggered by BellSouth's failure to achieve Enforcement Measurement Compliance or Enforcement Measurement Benchmarks for the State for a given Enforcement Measurement Element in a given month based upon a test statistic and balancing critical value calculated by BellSouth utilizing BellSouth generated data. The method of calculation is attached hereto as Exhibit D and incorporated herein by this reference.
 - 4.5.1.1 Tier-1 Enforcement Mechanisms apply on a per transaction basis for each negative cell and will escalate based upon the number of consecutive months that BellSouth has reported non-compliance.
 - 4.5.1.2 Fee Schedule for Tier-1 Enforcement Mechanisms is shown in Table-1 attached hereto as Exhibit E and incorporated herein by this reference. Failures beyond Month 6 (as set forth in Table 1) will be subject to Month 6 fees.
 - 4.5.2 Tier-2 Enforcement Mechanisms will be triggered by BellSouth's failure to achieve Enforcement Measurement Compliance or Enforcement Measurement Benchmarks for the State in a given calendar quarter based upon a statistically valid equation calculated by BellSouth utilizing

BellSouth generated data. The method of calculation is attached hereto as Exhibit D and incorporated herein by reference.

- 4.5.2.1 Tier- 2 Enforcement Mechanisms apply, for an aggregate of all CLEC data generated by BellSouth, on a per transaction basis for each negative cell for a particular Enforcement Measurement Element.
- 4.5.2.2 Fee Schedule for Total Quarterly Tier-2 Enforcement Mechanisms is show in Table-2 attached hereto as Exhibit E and incorporated herein by this reference.
- 4.5.3 Tier-3 Enforcement Mechanisms will be triggered by BellSouth's failure to achieve Enforcement Measurement Compliance or Enforcement Measurement Benchmarks for a State in a given calendar quarter. The method of calculation for specified submeasures is identical to the method of calculation for Tier-2 Enforcement Mechanisms as described above. The specific submeasures which are the mechanism for triggering and removing a Tier-3 Enforcement Mechanisms are described in more detail in Exhibit D attached hereto and incorporated herein by this reference.
- 4.6 Payment of Tier-1 and Tier-2 Amounts
- 4.6.1 If BellSouth performance triggers an obligation to pay Tier-1 Enforcement Mechanisms to Level 3 or an obligation to remit Tier-2 Enforcement Mechanisms to the Commission, BellSouth shall make payment in the required amount on or before the thirtieth (30th) day following the due date of the performance measurement report for the month in which the obligation arose.
- 4.6.2 For each day after the due date that BellSouth fails to pay Level 3 the required amount, BellSouth will pay interest to Level 3 at the maximum rate permitted by state law.
- 4.6.3 For each day after the due date that BellSouth fails to pay the Tier-2 Enforcement Mechanisms, BellSouth will pay the Commission an additional \$1,000 per day.
- 4.6.4 If Level 3 disputes the amount paid to Level 3 for Tier-1 Enforcement Mechanisms, Level 3 shall submit a written claim to BellSouth within sixty (60) days after the date of the performance measurement report for which the obligation arose. BellSouth shall investigate all claims and provide Level 3 written findings within thirty (30) days after receipt of the claim. If BellSouth determines Level 3 is owed additional amounts, BellSouth shall pay Level 3 such additional amounts within thirty (30)

days after its findings along with interest paid at the maximum rate permitted by law.

- 4.6.5 At the end of each calendar year, BellSouth will have its independent auditing and accounting firm certify that the results of all Tier-1 and Tier-2 Enforcement Mechanisms were paid and accounted for in accordance with Generally Accepted Account Principles (GAAP).
- 4.7 Limitations of Liability
- 4.7.1 BellSouth will not be responsible for Level 3 acts or omissions that cause performance measures to be missed or fail, including but not limited to accumulation and submission of orders at unreasonable quantities or times or failure to submit accurate orders or inquiries. BellSouth shall provide Level 3 with reasonable notice of such acts or omissions and provide Level 3 any such supporting documentation.
- 4.7.2 BellSouth shall not be obligated for Tier-1, Tier-2 or Tier 3 Enforcement Mechanisms for non-compliance with a performance measure if such non-compliance was the result of an act or omission by Level 3 that is in bad faith.
- 4.7.3 BellSouth shall not be obligated to pay Tier-1 Enforcement Mechanisms or Tier-2 Enforcement Mechanism for non-compliance with a performance measurement if such non-compliance was the result of any of the following: a Force Majeure event as set forth in the General Terms and Conditions of this Agreement; an act or omission by Level 3 that is contrary to any of its obligations under its Interconnection Agreement with BellSouth; an act or omission by Level 3 that is contrary to any of its obligations under the Act, Commission rule, or state law; an act or omission associated with third-party systems or equipment; or any occurrence that results from an incident reasonably related to the Y2K problem.
- 4.7.4 It is not the intent of the Parties that BellSouth be liable for both Tier-2 Enforcement Mechanisms and any other assessments or sanctions imposed by the Commission. Level 3 will not oppose any effort by BellSouth to set off Tier-2 Enforcement Mechanisms from any additional assessment imposed by the Commission.
- 4.7.5 Payment of any Tier-1 or Tier-2 Enforcement Mechanisms shall not be considered as an admission against interest or an admission of liability or culpability in any legal, regulatory or other proceeding relating to BellSouth's performance. The payment of any Tier-1 Enforcement Mechanisms to Level 3 shall release BellSouth for any liability associated

with or related to the service performance measurement for the month for which the Enforcement Mechanisms was paid to Level 3.

4.7.6 Level 3 acknowledges and argues that the Enforcement Mechanisms contained in this attachment have been provided by BellSouth on a completely voluntary basis in order to maintain compliance between BellSouth and Level 3. Therefore, Level 3 may not use the existence of this section or any payments of any Tier-1 or Tier-2 Enforcement Mechanisms under this section as evidence that BellSouth has not complied with or has violated any state or federal law or regulation.

4.8 Enforcement Mechanism Caps

4.8.1 BellSouth's liability for the payment of Tier-1 and Tier-2 Enforcement Mechanisms shall be collectively capped at \$625M per year for the entire BellSouth region as set forth below.

AL - \$54M	MS - \$44M
FL - \$122M	NC - \$77M
GA - \$131M	SC - \$47M
KY - \$34M	TN - \$57M
LA - \$59M	
Regional Total - \$625M	

4.8.2 If BellSouth's liability for the payment of Tier-1 and Tier-2 Enforcement Mechanisms exceed the caps referenced in this attachment, Level 3 may commence a proceeding with the Commission to demonstrate why BellSouth should pay any amount in excess of the cap. Level 3 shall have the burden of proof to demonstrate why, under the circumstances, BellSouth should have additional liability.

4.9 Dispute Resolution

4.9.1 Notwithstanding any other provision of this Agreement, any dispute regarding BellSouth's performance or obligations pursuant to this Attachment shall be resolved by the Commission.

EXHIBIT A

ORDERING

Report/Measurement:	
O-7. Speed of Answer in Ordering Center	
Definition:	
Measures the average time a customer is in queue.	
Exclusions:	
None	
Business Rules:	
The clock starts when the appropriate option is selected (i.e. 1 for Resale Consumer, 2 for Resale Multiline, and 3 for UNE-LNP, etc.) and the call enters the queue for that particular group in the LCSC. The clock stops when a BST service representative in the LCSC answers the call. The speed of answer is determined by measuring and accumulating the elapsed time from the entry of a CLEC call into the BellSouth automatic call distributor (ACD) until the a service representative in BSTs Local Carrier Service Center (LCSC) answers the CLEC call.	
Calculation:	
$(\text{Total time in seconds to reach the LCSC}) / (\text{Total Number of Calls})$ in the Reporting Period.	
Report Structure:	
<ul style="list-style-type: none"> • CLEC Aggregate • BST Aggregate (Combination of Residence Service Center and Business Service Center data under development) 	
Level of Disaggregation:	
<ul style="list-style-type: none"> • CLEC Aggregate • BST Aggregate (Combination of Residence Service Center and Business Service Center data under development) 	
Data Retained Relating to CLEC Experience:	Data Retained Relating to BST Performance:
<ul style="list-style-type: none"> • Mechanized tracking through LCSC Automatic Call Distributor 	<ul style="list-style-type: none"> • Mechanized tracking through BST Retail center support systems
Retail Analog/Benchmark:	
For CLEC, Speed of Answer in Ordering Center (LCSC) is comparable to Speed of Answer in BST Business Offices. See Appendix D	

Revision Date: 02/16/00 (lg)

ORDERING – (LNP)

Report/Measurement:
LNP-8. Percent Rejected Service Requests
Definition:
Percent Rejected Service Request is the percent of total Local Service Requests (LSRs) which are rejected due to error or omission. An LSR is considered valid when it is electronically submitted by the CLEC and passes LNP Gateway edit checks to insure the data received is correctly formatted and complete, i.e., fatal rejects are excluded.
Exclusions:
<ul style="list-style-type: none"> • Service Requests canceled by the CLEC • Fatal Rejects • Order Activities of BST or the CLEC associated with internal or administrative use of local services (Record Orders, Test Orders, etc.) where identifiable.
Business Rules:
<p>An LSR is considered “rejected” when it is submitted electronically but does not pass edit checks in the ordering systems (EDI, TAG, LNP Gateway, LAUTO) and is returned to the CLEC without manual intervention.</p> <p>Fully Mechanized: There are two types of “Rejects” in the Fully Mechanized category:</p> <ul style="list-style-type: none"> • A Fatal Reject occurs when a CLEC attempts to electronically submit an LSR (via EDI or TAG) but required fields are not populated correctly and the request is returned to the CLEC. Fatal rejects are reported in a separate column, and for informational purposes ONLY. They are not considered in the calculation of the percent of total LSRs rejected or the total number of rejected LSRs. • An Auto Clarification is a valid LSR which is electronically submitted (via EDI or TAG), but is rejected from LAUTO because it does not pass further edit checks for order accuracy. Auto Clarifications are returned without manual intervention. <p>Partially Mechanized: A valid LSR which is electronically submitted (via EDI or TAG), but cannot be processed electronically due to a CLEC error and “falls out” for manual handling. It is then put into “clarification”, and sent back to the CLEC.</p> <p>Total Mechanized: Combination of Fully Mechanized and Partially Mechanized rejects.</p>
Calculation
<p>Percent Rejected Service Requests:</p> $\frac{[(\text{Number of Service Requests Rejected in the Reporting Period}) / (\text{Number of Service Requests Received in the Reporting Period})] \times 100}{}$
Report Structure:
<ul style="list-style-type: none"> • Fully Mechanized, Partially Mechanized, Total Mechanized • CLEC Specific • CLEC Aggregate
Level of Disaggregation:
<ul style="list-style-type: none"> • Product Reporting Levels <ul style="list-style-type: none"> ➢ LNP ➢ UNE Loop with LNP • Geographic Scope <ul style="list-style-type: none"> ➢ .State, Region
Retail Analog/Benchmark:
See Appendix D

Revision Date: 02/16/00 (lg)

ORDERING – (LNP)

Report/Measurement:
LNP-9. Reject Interval Distribution & Average Reject Interval
Definition:
Reject Interval is the average reject time from receipt of an LSR to the distribution of a Reject. An LSR is considered valid when it is electronically submitted by the CLEC and passes LNP Gateway edit checks to insure the data received is correctly formatted and complete, i.e., fatal rejects are excluded.
Exclusions:
<ul style="list-style-type: none"> • Service Requests canceled by CLEC • Fatal Rejects • Order Activities of BST or the CLEC associated with internal or administrative use of local services (Record Orders, Test Orders, etc.) where identifiable.
Business Rules:
<p>The Reject interval is determined for each rejected LSR processed during the reporting period. The Reject interval is the elapsed time from when BST receives LSR until that LSR is rejected back to the CLEC. Elapsed time for each LSR is accumulated for each reporting dimension. The accumulated time for each reporting dimension is then divided by the associated total number of rejected LSRs to produce the reject interval distribution.</p> <p>An LSR is considered “rejected” when it is submitted electronically but does not pass edit checks in the ordering systems (EDI, TAG, LNP Gateway, LAUTO) and is returned to the CLEC without manual intervention.</p> <p>Fully Mechanized: There are two types of “Rejects” in the Fully Mechanized category:</p> <ul style="list-style-type: none"> • A Fatal Reject occurs when a CLEC attempts to electronically submit an LSR but required fields are not populated correctly and the request is returned to the CLEC. <i>Fatal rejects are reported in a separate column, and for informational purposes ONLY. They are not considered in the calculation of the percent of total LSRs rejected or the number of rejected LSRs.</i> • An Auto Clarification is a valid LSR which is electronically submitted (via EDI or TAG), but rejected from LAUTO because it does not pass further edit checks for order accuracy. Auto Clarifications are returned without manual intervention. <p>Partially Mechanized: A valid LSR which is electronically submitted (via EDI or TAG), but cannot be processed electronically due to a CLEC error and “falls out” for manual handling. It is then put into “clarification”, and sent back to the CLEC.</p> <p>Total Mechanized: Combination of Fully Mechanized and Partially Mechanized rejects.</p>
Calculation:
<p>Average Reject Interval: $\frac{\Sigma[(\text{Date \& Time of Service Request Rejection}) - (\text{Date \& Time of Service Request Receipt})]}{(\text{Total Number of Service Requests Rejected in Reporting Period})}$</p> <p>Reject Interval Distribution: $[\Sigma(\text{Service Requests Rejected in “X” minutes/hours}) / (\text{Total Number of Service Requests Rejected in Reporting Period})] \times 100$</p>
Report Structure:
<ul style="list-style-type: none"> • Fully Mechanized, Partially Mechanized, Total Mechanized • CLEC Specific • CLEC Aggregate

ORDERING – (LNP) - Reject Interval Distribution & Average Reject Interval – Continued)

Level of Disaggregation: <ul style="list-style-type: none">• Reported in intervals = 0 - 4 minutes, 4 - 8 minutes, 8 - 12 minutes, 12 - 60 minutes, 0 - 1 hours, 1 - 8 hours, 8 - 24 hours, >24 hours• Product Reporting Levels<ul style="list-style-type: none">➢ LNP➢ UNE Loop with LNP• Geographic Scope<ul style="list-style-type: none">➢ .State, Region• Average Interval in Days
Retail Analog/Benchmark:
See Appendix D

Revision Date: 02/16/00 (lg)

ORDERING – (LNP)

Report/Measurement:
LNP-10. Firm Order Confirmation Timeliness Interval Distribution & Firm Order Confirmation Average Interval
Definition:
Interval for Return of a Firm Order Confirmation (FOC Interval) is the average response time from receipt of a valid LSR to distribution of a firm order confirmation.
Exclusions:
<ul style="list-style-type: none"> • Rejected LSRs (Clarifications or Fatal Rejects) • Order Activities of BST or the CLEC associated with internal or administrative use of local services (Record Orders, Test Orders, etc.) where identifiable.
Business Rules:
<p>The Firm Order Confirmation interval is determined for each FOC'd LSR processed during the reporting period. The Firm Order Confirmation interval is the elapsed time from when BST receives an LSR until that LSR is confirmed back to the CLEC. Elapsed time for each LSR is accumulated for each reporting dimension. The accumulated time for each reporting dimension is then divided by the associated total number of orders completed to produce the Firm Order Confirmation timeliness interval distribution.</p> <ul style="list-style-type: none"> • Mechanized - The elapsed time from receipt of a valid LSR until the LSR is processed and appropriate service orders are generated in SOCS without manual intervention. • Partially Mechanized - The elapsed time from receipt of an electronically submitted LSR which falls out for manual handling by the LCSC personnel until appropriate service orders are issued by a BST service representative via Direct Order Entry (DOE) or Service Order Negotiation Generation System (SONGS). • Total Mechanized - Combination of Fully Mechanized and Partially Mechanized FOCs.
Calculation:
<p>Average FOC Interval: $\Sigma [(Date \& Time \text{ of Firm Order Confirmation}) - (Date \& Time \text{ of Service Request Receipt})] / (\text{Total number of Service Requests Confirmed in the Reporting Period})$</p> <p>FOC Interval Distribution: $\Sigma [(\text{Service Requests Confirmed in "X" minutes/hours in the Reporting Period}) / (\text{Total Service Requests Confirmed in the Reporting Period})] \times 100$</p>
Report Structure:
<ul style="list-style-type: none"> • Fully Mechanized, Partially Mechanized, Total Mechanized • CLEC Specific • CLEC Aggregate
Level of Disaggregation:
<ul style="list-style-type: none"> • Reported in intervals = 0 - 15 minutes, 15 - 30 minutes, 30 - 45 minutes, 45 - 60 minutes, 90 - 120 minutes, 120 - 240 minutes, 4 - 8 hours, 8 - 12 hours, 12 - 16 hours, 16 - 20 hours, 20 - 24 hours, 24 - 48 hours, >48 hours • Product Reporting Levels <ul style="list-style-type: none"> ➢ LNP ➢ UNE Loop with LNP • Geographic Scope <ul style="list-style-type: none"> ➢ .State, Region
Retail Analog/Benchmark:
See Appendix D

Revision Date: 02/16/00 (lg)

Provisioning Disaggregation

Product Reporting Levels

- Resale and Retail
 - POTS – Residence
 - POTS – Business
 - Design
 - PBX (Louisiana SQM)
 - CENTREX (Louisiana SQM)
 - ISDN (Louisiana SQM) (**NOTE:** ISDN included in POTS for Georgia Only)
 - ESSX (Louisiana SQM)

- Unbundled Network Elements
 - UNE Design
 - UNE Non – Design
 - UNE 2 Wire Loop (Louisiana SQM)
 - UNE Loop Other (Louisiana SQM)
 - Unbundled Ports (Louisiana SQM)

- Trunks
 - Local Interconnection Trunks

- Geographic Scope
 - State, Region and further geographic disaggregation as required by State Commission Order (e.g. Metropolitan Service Area – MSA)

The following measure is the exception for all states:

Coordinated Customer Conversion

Which is disaggregated as follows:

UNE LOOPS with INP

UNE LOOPS without INP

PROVISIONING

Report/Measurement:
P-1. Mean Held Order Interval & Distribution Intervals
Definition:
When delays occur in completing CLEC orders, the average period that CLEC orders are held for BST reasons, pending a delayed completion, should be no worse for the CLEC when compared to BST delayed orders.
Exclusions:
Order Activities of BST associated with internal or administrative use of local services.
Business Rules:
<p>Mean Held Order Interval: This metric is computed at the close of each report period. The held order interval is established by first identifying all orders, at the close of the reporting interval, that both have not been reported as completed in SOCS and have passed the currently committed due date for the order. For each such order, the number of calendar days between the committed due date and the close of the reporting period is established and represents the held order interval for that particular order. The held order interval is accumulated by the standard groupings, unless otherwise noted, and the reason for the order being held. The total number of days accumulated in a category is then divided by the number of held orders within the same category to produce the mean held order interval. The interval is by calendar days with no exclusions for Holidays or Sundays.</p> <p>CLEC Specific reporting is by type of held order (facilities, equipment, other), total number of orders held, and the total and average days.</p> <p>Held Order Distribution Interval: This measure provides data to report total days held and identifies these in categories of >15 days and > 90 days. (orders counted in >90 days are also included in >15 days).</p>
Calculation:
<p>Mean Held Order Interval: $\frac{\Sigma(\text{Reporting Period Close Date} - \text{Committed Order Due Date})}{(\text{Number of Orders Pending and Past The Committed Due Date})}$ for all orders pending and past the committed due date.</p> <p>Held Order Distribution Interval: $\frac{(\# \text{ of Orders Held for } \geq 90 \text{ days})}{(\text{Total } \# \text{ of Orders Pending But Not Completed})} \times 100$ $\frac{(\# \text{ of Orders Held for } \geq 15 \text{ days})}{(\text{Total } \# \text{ of Orders Pending But Not Completed})} \times 100$</p>
Report Structure:
<ul style="list-style-type: none"> • CLEC Specific • CLEC Aggregate • BST Aggregate
Level of Disaggregation:
Circuit breakout < 10, > = 10

PROVISIONING - Mean Held Order Interval & Distribution Intervals – Continued)

Data Retained Relating to CLEC Experience	Data Retained Relating to BST Experience
<ul style="list-style-type: none"> • Report Month • CLEC Order Number and PON (PON) • Order Submission Date (TICKET_ID) • Committed Due Date (DD) • Service Type(CLASS_SVC_DESC) • Hold Reason • Total line/circuit count • Geographic Scope <p>NOTE: Code in parentheses is the corresponding header found in the raw data file.</p>	<ul style="list-style-type: none"> • Report Month • BST Order Number • Order Submission Date • Committed Due Date • Service Type • Hold Reason • Total line/circuit count • Geographic Scope
<p>Retail Analog/Benchmark: CLEC Residence Resale / BST Residence Retail CLEC Business Resale / BST Business Retail CLEC Non-UNE Design / BST Design Interconnection Trunks-CLEC / Interconnection Trunks –BST UNES-(See Appendix D)</p>	

Revision Date: 02/24/00 (taf)

PROVISIONING

Report/Measurement:	
P-2. Average Jeopardy Notice Interval & Percentage of Orders Given Jeopardy Notices	
Definition:	
When BST can determine in advance that a committed due date is in jeopardy, it will provide advance notice to the CLEC.	
Exclusions:	
<ul style="list-style-type: none"> • Orders held for CLEC end user reasons • Orders submitted to BST through non-mechanized methods 	
Business Rules:	
When BST can determine in advance that a committed due date is in jeopardy it will provide advance notice to the CLEC. The number of committed orders in a report period is the number of orders that have a due date in the reporting period.	
Calculation:	
Average Jeopardy Interval = $\Sigma [(\text{Date and Time of Scheduled Due Date on Service Order}) - (\text{Date and Time of Jeopardy Notice})] / [\text{Number of Orders Notified of Jeopardy in Reporting Period}]$ Percent of Orders Given Jeopardy Notice = $\Sigma [(\text{Number of Orders Given Jeopardy Notices in Reporting Period}) / (\text{Number of Orders Confirmed (due) in Reporting Period})]$	
Report Structure:	
<ul style="list-style-type: none"> • CLEC Specific • CLEC Aggregate • BST Aggregate 	
Data Retained Relating to CLEC Experience	Data Retained Relating to BST Experience
<ul style="list-style-type: none"> • Report Month • CLEC Order Number and PON • Date and Time Jeopardy Notice sent • Committed Due Date • Service Type 	<ul style="list-style-type: none"> • Report Month • BST Order Number • Date and Time Jeopardy Notice sent • Committed Due Date • Service type
NOTE: Code in parentheses is the corresponding header found in the raw data file.	
Retail Analog/Benchmark:	
95% > = 24 hours	

Revision Date: 01/05/00 (taf)

PROVISIONING

Report/Measurement:	
P-3. Percent Missed Installation Appointments	
Definition:	
“Percent missed installation appointments” monitors the reliability of BST commitments with respect to committed due dates to assure that CLECs can reliably quote expected due dates to their retail customer as compared to BST.	
Exclusions:	
<ul style="list-style-type: none"> • Canceled Service Orders • Order Activities of BST or the CLEC associated with internal or administrative use of local services (Record Orders, Test Orders, etc.) • Disconnect (D) & From (F) orders • End User Misses on Interconnection Trunks 	
Business Rules:	
Percent Missed Installation Appointments is the percentage of total orders processed for which BST is unable to complete the service orders on the confirmed due dates. Missed Appointments caused by end-user reasons will be included and reported separately. A business day is any time period within the same date frame, which means there cannot be a cutoff time for commitments as certain types of orders are requested to be worked after standard business hours. Also, during Daylight Savings Time, field technicians are scheduled until 9PM in some areas and the customer is offered a greater range of intervals from which to select.	
Calculation:	
Percent Missed Installation Appointments = Σ (Number of Orders Not Complete by Committed Due Date in Reporting Period) / (Number of Orders Confirmed in Reporting Period) X 100	
Report Structure:	
<ul style="list-style-type: none"> • CLEC Specific • CLEC Aggregate • BST Aggregate <p>Report explanation: The difference between End User MA and Total MA is the result of BST caused misses. Here, Total MA is the total % of orders missed either by BST or CLEC end user. The End User MA represents the percentage of orders missed by the CLEC or their end user.</p>	
Level of Disaggregation:	
<ul style="list-style-type: none"> • Reported in categories of <10 lines/circuits; > = 10 lines/circuits • Dispatch/No Dispatch 	
Data Retained Relating to CLEC Experience	Data Retained Relating to BST Experience
<ul style="list-style-type: none"> • Report Month • CLEC Order Number and PON (PON) • Committed Due Date (DD) • Completion Date (CMPLTN DD) • Status Type • Status Notice Date • Standard Order Activity • Geographic Scope 	<ul style="list-style-type: none"> • Report Month • BST Order Number • Committed Due Date (DD) • Completion Date (CMPLTN DD) • Status Type • Status Notice Date • Standard Order Activity • Geographic Scope
NOTE: Code in parentheses is the corresponding header found in the raw data file.	
Retail Analog/Benchmark:	
CLEC Residence Resale / BST Residence Retail CLEC Business Resale / BST Business Retail CLEC Non-UNE Design / BST Design Interconnection Trunks-CLEC / Interconnection Trunks –BST UNEs-(See Appendix D)	

Revision Date: 02/28/00 (taf)

PROVISIONING

Report/Measurement :
P-4. Average Completion Interval (OCI) & Order Completion Interval Distribution
Definition:
The “average completion interval” measure monitors the interval of time it takes BST to provide service for the CLEC or its’ own customers. The “Order Completion Interval Distribution” provides the percentage of orders completed within certain time periods.
Exclusions:
<ul style="list-style-type: none"> • Canceled Service Orders • Order Activities of BST or the CLEC associated with internal or administrative use of local services (Record Orders, Test Orders, etc.) • D (Disconnect) and F (From) orders. (From is disconnect side of a move order when the customer moves to a new address). • “L” Appointment coded orders (where the customer has requested a later than offered interval)
Business Rules:
The actual completion interval is determined for each order processed during the reporting period. The completion interval is the elapsed time from when BST issues a FOC or SOCS date time stamp receipt of an order from the CLEC to BST’s actual order completion date. The clock starts when a valid order number is assigned by SOCS and stops when the technician or system completes the order in SOCS. Elapsed time for each order is accumulated for each reporting dimension. The accumulated time for each reporting dimension is then divided by the associated total number of orders completed.
The interval breakout for UNE and Design is: 0-5 = 0-4.99, 5-10 = 5-9.99, 10-15 = 10-14.99, 15-20 = 15-19.99 20-25 = 20-24.99, 25-30 = 25-29.99, >=30 = 30 and greater.
Calculation :
Average Completion Interval: $\Sigma [(\text{Completion Date \& Time}) - (\text{Order Issue Date \& Time})] / \Sigma (\text{Count of Orders Completed in Reporting period})$
Order Completion Interval Distribution: $\Sigma (\text{Service Orders Completed in “X” days}) / (\text{Total Service Orders Completed in Reporting Period}) \times 100$
Report Structure:
<ul style="list-style-type: none"> • CLEC Specific • CLEC Aggregate • BST Aggregate
Level of Disaggregation:
<ul style="list-style-type: none"> • ISDN Orders included in Non Design - GA Only • Dispatch/No Dispatch categories applicable to all levels except trunks. • Residence & Business reported in day intervals = 0,1,2,3,4, 5, 5+ • UNE and Design reported in day intervals = 0-5, 5-10, 10-15, 15-20, 20-25, 25-30, >=30 • All Levels are reported <10 line/circuits; >=10 line/circuits

PROVISIONING –
(Average Completion Interval (OCI) & Order Completion Interval Distribution – Continued)

Data Retained Relating to CLEC Experience	Data Retained Relating to BST Experience
<ul style="list-style-type: none"> • Report Month • CLEC Company Name • Order Number (PON) • Submission Date & Time (TICKET_ID) • Completion Date (Cmpltn_DT) • Service Type (CLASS_SVC_DESC) • Geographic Scope <p>NOTE: Code in parentheses is the corresponding header found in the raw data file.</p>	<ul style="list-style-type: none"> • Report Month • BST Order Number • Order Submission Date & Time • Order Completion Date & Time • Service Type • Geographic Scope
<p>Retail Analog/Benchmark</p> <p>CLEC Residence Resale / BST Residence Retail CLEC Business Resale / BST Business Retail CLEC Non-UNE Design / BST Design Interconnection Trunks-CLEC / Interconnection Trunks-BST UNEs-(See Appendix D)</p>	

Revision Date: 02/28/00 (taf)

PROVISIONING

Report/Measurement:	
P-5. Average Completion Notice Interval	
Definition:	
The Completion Notice Interval is the elapsed time between the BST reported completion of work and the issuance of a valid completion notice to the CLEC.	
Exclusions:	
<ul style="list-style-type: none"> • Non-mechanized Orders • Cancelled Service Orders • Order Activities of BST associated with internal or administrative use of local services • D & F orders 	
Business Rules:	
Measurement of interval of completion date and time by a field technician on dispatched orders, and 5PM start time on the due date for non-dispatched orders; to the release of a notice to the CLEC/BST of the completion status. The field technician notifies the CLEC the work was complete and then he enters the completion time stamp information in his computer. This information switches through to the SOCS systems either completing the order or rejecting the order to the Work Management Center (WMC). If the completion is rejected, it is manually corrected and then completed by the WMC. The notice is returned on each individual order submitted and as the notice is sent electronically, it can only be switched to those orders that were submitted by the CLEC electronically. The start time is the completion stamp either by the field technician or the 5PM due date stamp; the end time is the time stamp the notice was submitted to the CLEC/BST system.	
Calculation:	
Σ (Date and Time of Notice of Completion) – (Date and Time of Work Completion) / (Number of Orders Completed in Reporting Period)	
Report Structure:	
<ul style="list-style-type: none"> • CLEC Specific • CLEC Aggregate • BST Aggregate 	
Level of Disaggregation:	
<ul style="list-style-type: none"> • Reporting intervals in Hours: 0-1, 1-2, 2-4, 4-8, 8-12, 12-24, > 24, plus Overall Average Hour Interval • Reported in categories of <10 line/circuits; >= 10 line/circuits 	
Data Retained Relating to CLEC Experience	Data Retained Relating to BST Experience
<ul style="list-style-type: none"> • Report Month • CLEC Order Number • Work Completion Date • Work Completion Time • Completion Notice Availability Date • Completion Notice Availability Time • Service Type • Activity Type • Geographic Scope 	<ul style="list-style-type: none"> • Report Month • BST Order Number • Work Completion Date • Work Completion Time • Completion Notice Availability Date • Completion Notice Availability Time • Service Type • Activity Type • Geographic Scope
NOTE: Code in parentheses is the corresponding header found in the raw data file.	NOTE: Code in parentheses is the corresponding header found in the raw data file.
Retail Analog/Benchmark:	
CLEC Residence Resale / BST Residence Retail CLEC Business Resale / BST Business Retail CLEC Non-UNE Design / BST Design Interconnection Trunks-CLEC / Interconnection Trunks-BST UNEs – (See Appendix D)	

Revision Date 02/24/00 (taf)

PROVISIONING

Report/Measurement:	
P-6. Coordinated Customer Conversions	
Definition:	
This category measures the average time it takes BST to disconnect an unbundled loop from the BST switch and cross connect it to a CLEC's equipment. This measurement applies to service orders with and without INP, and where the CLEC has requested BST to provide a coordinated cutover.	
Exclusions:	
<ul style="list-style-type: none"> • Any order canceled by the CLEC will be excluded from this measurement. • Delays due to CLEC following disconnection of the unbundled loop • Unbundled Loops where there is no existing subscriber loop and loops where coordination is not requested. 	
Business Rules:	
Where the service order includes INP, the interval includes the total time for the cutover including the translation time to place the line back in service on the ported line. The interval is calculated for the entire cutover time for the service order and then divided by items worked in that time to give the average per item interval for each service order.	
Calculation:	
$\frac{\sum [(Completion\ Date\ and\ Time\ for\ Cross\ Connection\ of\ an\ Coordinated\ Unbundled\ Loop) - (Disconnection\ Date\ and\ Time\ of\ an\ Coordinated\ Unbundled\ Loop)]}{Total\ Number\ of\ Unbundled\ Loop\ with\ Coordinated\ Conversions\ (items)\ for\ the\ reporting\ period.}$	
Report Structure:	
<ul style="list-style-type: none"> • CLEC Specific • CLEC Aggregate 	
Level of Disaggregation:	
Reported in intervals <=5 minutes; >5,<=15 minutes; >15 minutes, plus Overall Average interval	
Data Retained Relating to CLEC Experience	Data Retained Relating to BST Experience
<ul style="list-style-type: none"> • Report Month • CLEC Order Number • Committed Due Date (DD) • Service Type (CLASS_SVC_DESC) • Cutover Start Time • Cutover Completion time • Portability start and completion times (INP orders) • Total Conversions (Items) <p>NOTE: Code in parentheses is the corresponding header found in the raw data file.</p>	<ul style="list-style-type: none"> • No BST Analog Exists
Retail Analog/Benchmark:	
There is no retail analog for this measurement because it measures cutting loops to the CLEC. Benchmark – See Appendix D	

Revision Date: 02/28/00 (taf)

PROVISIONING

Report/Measurement:	
P-7. % Provisioning Troubles within 30 days of Service Order Activity	
Definition:	
Percent Provisioning Troubles within 30 days of Installation measures the quality and accuracy of installation activities.	
Exclusions:	
<ul style="list-style-type: none"> • Canceled Service Orders • Order Activities of BST or the CLEC associated with internal or administrative use of local services (R Orders, Test Orders, etc.) • D & F orders 	
Business Rules:	
Measures the quality and accuracy of completed orders. The first trouble report from a service order after completion is counted in this measure. Subsequent trouble reports are measured in Repeat Report Rate. Reports are calculated searching in the prior report period for completed service orders and following 30 days after completion for a trouble report.	
D & F orders are excluded as there is no subsequent activity following a disconnect.	
Calculation:	
$\% \text{ Provisioning Troubles within 30 days of Service Order Activity} = \frac{\sum (\text{Trouble reports on all completed orders} \leq 30 \text{ days following service order(s) completion})}{(\text{All Service Orders completed in the report calendar month})} \times 100$	
Report Structure:	
<ul style="list-style-type: none"> • CLEC Specific • CLEC Aggregate • BST Aggregate 	
Level of Disaggregation:	
<ul style="list-style-type: none"> • Reported in categories of <10 line/circuits; > = 10 line/circuits • Dispatch / No Dispatch 	
Data Retained Relating to CLEC Experience	Data Retained Relating to BST Experience
<ul style="list-style-type: none"> • Report Month • CLEC Order Number and PON • Order Submission Date(TICKET_ID) • Order Submission Time (TICKET_ID) • Status Type • Status Notice Date • Standard Order Activity • Geographic Scope 	<ul style="list-style-type: none"> • Report Month • BST Order Number • Order Submission Date • Order Submission Time • Status Type • Status Notice Date • Standard Order Activity • Geographic Scope
NOTE: Code in parentheses is the corresponding header found in the raw data file.	
Retail Analog/Benchmark:	
CLEC Residence Resale / BST Residence Retail CLEC Business Resale / BST Business Retail CLEC Non-UNE_Design / BST Design Interconnection Trunks-CLEC / Interconnection Trunks –BST UNEs-(See Appendix D)	

Revision Date: 02/28/00 (taf)

PROVISIONING

Report/Measurement :	
P-8. Total Service Order Cycle Time (TSOCT)	
Definition:	
This report measures the total service order cycle time from receipt of a valid service order request to the completion of the service order.	
Exclusions:	
<ul style="list-style-type: none"> • Canceled Service Orders • Order Activities of BST or the CLEC associated with internal or administrative use of local services (Record Orders, Test Orders, etc.) • D (Disconnect) and F (From) orders. (From is disconnect side of a move order when the customer moves to a new address). • “L” Appointment coded orders (where the customer has requested a later than offered interval) • Orders with CLEC/Subscriber caused delays or CLEC/Subscriber requested due date changes. 	
Business Rules:	
<p>The interval is determined for each order processed during the reporting period. This measurement combines two reports: FOC (Firm Order Confirmation) with Average Order Completion Interval.</p> <p>This interval starts with the receipt of a valid service order request and stops when the technician or system completes the order in SOCS. Elapsed time for each order is accumulated for each reporting dimension. The accumulated time for each reporting dimension is then divided by the associated total number of orders completed.</p>	
Calculation :	
<p>Total Service Order Cycle Time $\frac{\Sigma(\text{Date and Time of Service Request Receipt}) - (\text{Completion Date and Time of Service Order}) (\text{SOCS HIST-CD DATE})}{(\text{Count of Orders Completed in Reporting Period})}$ </p>	
Report Structure:	
<ul style="list-style-type: none"> • CLEC Specific • CLEC Aggregate • BST Aggregate 	
Level of Disaggregation:	
<ul style="list-style-type: none"> • Reported in categories of < 10 line/circuits; > = 10 line/circuits • Dispatch/No Dispatch categories applicable to all levels except trunks. • Intervals 0-5, 5-10, 10-15, 15-20, 20-25, 25-30, > = 30 Days 	
Data Retained Relating to CLEC Experience	Data Retained Relating to BST Experience
<ul style="list-style-type: none"> • Report Month • Interval for FOC • CLEC Company Name • Order Number (PON) • Submission Date & Time (TICKET_ID) • Completion Date (CMPLTN_DT) • Service Type (CLASS_SVC_DESC) • Geographic Scope 	<ul style="list-style-type: none"> • Report Month • BST Order Number • Order Submission Date & Time • Order Completion Date & Time • Service Type • Geographic Scope
<p>NOTE: Code in parentheses is the corresponding header found in the raw data file.</p>	
Retail Analog/Benchmark	
See Appendix D	

Revision Date: 02/28/00 (taf)

PROVISIONING

Report/Measurement:	
P-9. Service Order Accuracy GEORGIA ONLY	
Definition:	
The “service order accuracy” measurement measures the accuracy and completeness of BST service orders by comparing what was ordered and what was completed.	
Exclusions:	
<ul style="list-style-type: none"> • Cancelled Service Orders • Order Activities of BST associated with internal or administrative use of local services • & F orders 	
Business Rules:	
A manual sampling of service orders, completed during a monthly reporting period, is compared to the original account profile and the order that the CLEC sent to BST. An order is “completed without error” if all service attributes and account detail changes (as determined by comparing the original order) completely and accurately reflect the activity specified on the original order and any supplemental CLEC order.	
Calculation:	
Percent Service Order Accuracy = Σ (Orders Completed without Error) / Σ (Orders Completed in Reporting Period) x 100	
Report Structure:	
CLEC Aggregate	
Level of Disaggregation:	
<ul style="list-style-type: none"> • Reported in categories of <10 line/circuits; > = 10 line/circuits • Dispatch / No Dispatch 	
Data Retained Relating to CLEC Experience	Data Retained Relating to BST Experience
<ul style="list-style-type: none"> • Report Month • CLEC Order Number and PON • Local Service Request (LSR) • Order Submission Date • Committed Due Date • Service Type • Standard Order Activity 	<ul style="list-style-type: none"> • Being investigated at this time
NOTE: Code in parentheses is the corresponding header found in the raw data file.	
Retail Analog/Benchmark: (Under Investigation)	

Revision Date: 01/05/00 (taf)

PROVISIONING

Report/Measurement:
LNP – 10. Percent Missed Installation Appointments
Definition:
Percent Missed Installation Appointments monitors the reliability of BST commitments with respect to committed due dates to assure that CLECs can reliably quote expected due dates to their retail customer as compared to BST.
Exclusions:
<ul style="list-style-type: none"> • Canceled Service Orders • Order Activities of BST or the CLEC associated with internal or administrative use of local services (Record Orders, Test Orders, etc.) where identifiable.
Business Rules:
Percent Missed Installation Appointments (PMI) is the percentage of total orders processed for which BST is unable to complete the service orders on the committed due dates. Missed Appointments caused by end-user reasons will be included and reported in a separate category. A business day is any time period within the same date frame, which means there cannot be a cutoff time for commitments as certain types of orders are requested to be worked after standard business hours. Also, during Daylight Savings Time, field technicians are scheduled until 9PM in some areas and the customer is offered a greater range of intervals from which to select.
Calculation:
<p>Percent Missed Installation Appointments: $\left[\frac{\text{(Number of Orders Not Completed by Committed Due Date in Reporting Period)}}{\text{(Number of Orders Completed in Reporting Period)}} \right] \times 100$</p>
Report Structure:
<ul style="list-style-type: none"> • Mechanized (service orders generated by LSRs submitted via EDI or TAG) • CLEC Specific • CLEC Aggregate <p>Report explanation: Total Missed Appointments is the total % of orders missed either by BST or the CLEC end user. End User MA represents the percentage of orders missed by the CLEC end user. The difference between End User Missed Appointments and Total Missed Appointments is the result of BST caused misses.</p>
Level of Disaggregation:
<ul style="list-style-type: none"> • Product Reporting Levels <ul style="list-style-type: none"> ➢ LNP ➢ UNE Loop Associated w/LNP • Geographic Scope <ul style="list-style-type: none"> ➢ State, Region
Retail Analog/Benchmark:
See Appendix D

Revision Date: 02/16/00 (taf)

PROVISIONING – (LNP)

Report/Measurement :
LNP-11. Average Disconnect Timeliness Interval & Disconnect Timeliness Interval Distribution
Definition:
Disconnect Timeliness is defined as the interval between the time the LNP Gateway receives the ‘Number Ported’ message from NPAC (signifying the CLEC ‘Activate’) until the time that the Disconnect service order for an LSR is completed in SOCS. This interval effectively measures BST responsiveness by isolating it from impacts that are caused by CLEC related activities.
Exclusions:
<ul style="list-style-type: none"> • Canceled Service Orders • Order Activities of BST or the CLEC associated with internal or administrative use of local services (Record Orders, Test Orders, etc.) where identifiable.
Business Rules:
The Disconnect Timeliness interval is determined for the last Disconnect service order processed on an LSR during the reporting period. The Disconnect Timeliness interval is the elapsed time from when BST receives the last ‘Number Ported’ message for an LSR from NPAC (signifying the CLEC ‘Activate’) until the last Disconnect service order is completed in SOCS. Elapsed time for each order is accumulated for each reporting dimension. The accumulated time for each reporting dimension is then divided by the total number of selected disconnect orders which have been completed.
Calculation :
<p>Average Disconnect Timeliness Interval: $\frac{\sum [(\text{Disconnect Service Order Completion Date \& Time}) - (\text{‘Number Ported’ Message Received Date \& Time})]}{\sum (\text{Total Number of Disconnect Service Orders Completed in Reporting Period})}$</p> <p>Disconnect Timeliness Interval Distribution: $[\frac{\sum (\text{Disconnect Service Orders Completed in “X” days})}{\sum (\text{Total Disconnect Service Orders Completed in Reporting Period})}] \times 100$</p>
Report Structure:
<ul style="list-style-type: none"> • Mechanized (service orders generated by LSRs submitted via EDI or TAG) • CLEC Specific • CLEC Aggregate
Level of Disaggregation:
<ul style="list-style-type: none"> • Reported in day intervals = 0,1,2,3,4, 5, >5 days • Product Reporting Levels <ul style="list-style-type: none"> ➢ LNP • Geographic Scope <ul style="list-style-type: none"> ➢ State, Region
Retail Analog/Benchmark:
See Appendix D

Revision Date: 02/16/00 (taf)

PROVISIONING

Report/Measurement :
LNP-12. Total Service Order Cycle Time
Definition:
Total Service Order Cycle Time measures the interval from receipt of a valid service order request to the completion of the final service order associated with that service request.
Exclusions:
<ul style="list-style-type: none"> • Canceled Service Orders • Order Activities of BST or the CLEC associated with internal or administrative use of local services (Record Orders, Test Orders, etc.) where identifiable • “L” appointment coded orders (indicating the customer has requested a later than offered interval) • ”S” missed appointment coded orders (indicating subscriber missed reasons), except for “SP” codes (indicating subscriber prior due date requested).
Business Rules:
<p>The interval is determined for each service request processed during the reporting period. This measurement combines two reports: FOC (Firm Order Confirmation) with Average Order Completion Interval.</p> <p>This interval starts with the receipt of a valid service request and stops when the technician or system completes all the related service orders for the LSR in SOCS. Elapsed time for each service request is accumulated for each reporting dimension. The accumulated time for each reporting dimension is then divided by the associated total number of service requests completed to produce the total service order cycle time.</p>
Calculation :
<p>Average Total Service Order Cycle Time: $\frac{\sum [(\text{Service Order Completion Date \& Time}) - (\text{Service Request Receipt Date \& Time})]}{\sum (\text{Total Number Service Requests Completed in Reporting Period})}$</p> <p>Total Service Order Cycle Time Interval Distribution: $[\frac{\sum (\text{Total Number of Service Requests Completed in “X” minutes/hours})}{(\text{Total Number of Service Requests Received in Reporting Period})}] \times 100$</p>
Report Structure:
<ul style="list-style-type: none"> • Mechanized (service orders generated by LSRs submitted via EDI or TAG) • CLEC Specific • CLEC Aggregate • “W” Appointment Code Only (Company Offered)
Level of Disaggregation:
<ul style="list-style-type: none"> • Reported in day intervals 0 - 5, 5 - 10, 10 - 15, 15 - 20, 20 - 25, 25 - 30, >30 days • Product Reporting Levels <ul style="list-style-type: none"> ➢ LNP ➢ UNE Loop with LNP • Geographic Scope <ul style="list-style-type: none"> ➢ State, Region
Retail Analog/Benchmark:
See Appendix D

Revision Date: 02/16/00

(taf)

Maintenance and Repair Level of Disaggregation

Product Reporting Levels

- Resale / Retail
 - Pots – Residence
 - Pots – Business
 - PBX (Louisiana SQM)
 - ESSX (Louisiana SQM)
 - CENTREX (Louisiana SQM)
 - ISDN (Louisiana SQM) (NOTE: ISDN Troubles included in Non-Design Georgia Only)
 - Design

- Unbundled Network Elements
 - UNE Design
 - UNE Non – Design
 - UNE 2 Wire Loop (Louisiana SQM)
 - UNE Loop Other (Louisiana SQM)
 - Unbundled Ports (Louisiana SQM)
 - UNE Other Non – Design (Louisiana SQM)

- Trunks
 - Local Interconnection Trunks

- Dispatch/No Dispatch categories applicable to all product levels

- Geographic Scope
 - State, Region and further geographic disaggregation as required by State Commission Order (e.g. Metropolitan Service Area – MSA)

MAINTENANCE & REPAIR

Report/Measurement:	
M&R-1. Missed Repair Appointments	
Definition:	
The percent of trouble reports not cleared by the committed date and time.	
Exclusions:	
<ul style="list-style-type: none"> • Trouble tickets canceled at the CLEC request. • BST trouble reports associated with internal or administrative service. • Customer Provided Equipment (CPE) troubles or CLEC Equipment Trouble. 	
Business Rules:	
The negotiated commitment date and time is established when the repair report is received. The cleared time is the date and time that BST personnel clear the trouble and closes the trouble report in his Computer Access Terminal (CAT) or workstation. If this is after the Commitment time, the report is flagged as a “Missed Commitment” or a missed repair appointment. When the data for this measure is collected for BST and a CLEC, it can be used to compare the percentage of the time repair appointments are missed due to BST reasons. Note: Appointment intervals vary with force availability in the POTS environment. Specials and Trunk intervals are standard interval appointments of no greater than 24 hours.	
Calculation:	
Percentage of Missed Repair Appointments = $\frac{\Sigma (\text{Count of Customer Troubles Not Cleared by the Quoted Commitment Date and Time})}{\Sigma (\text{Total Trouble reports closed in Reporting Period})} \times 100$	
Report Structure:	
<ul style="list-style-type: none"> • CLEC Specific • CLEC Aggregate • BST Aggregate 	
Data Retained Relating to CLEC Experience	Data Retained Relating to BST Experience
<ul style="list-style-type: none"> • Report Month • CLEC Company Name • Submission Date & Time (TICKET_ID) • Completion Date (CMPLTN_DT) • Service Type (CLASS_SVC_DESC) • Disposition and Cause (CAUSE_CD & CAUSE_DESC) • Geographic Scope 	<ul style="list-style-type: none"> • Report Month • BST Company Code • Submission Date & Time • Completion Date • Service Type • Disposition and Cause (Non-Design /Non-Special Only) • Trouble Code (Design and Trunking Services) • Geographic Scope
NOTE: Code in parentheses is the corresponding header found in the raw data file.	
Retail Analog/Benchmark	
CLEC Residence-Resale / BST Residence-Retail CLEC Business-Resale / BST Business-Retail CLEC Design-Resale / BST Design-Retail CLEC PBX, Centrex, and ISDN Resale/ BST PBX, Centrex, and ISDN Retail CLEC Trunking-Resale / BST Trunking-Retail UNEs – (See Appendix D)	

Revision Date: 02/22/00 (see)

MAINTENANCE & REPAIR

Report/Measurement:	
M&R-2. Customer Trouble Report Rate	
Definition:	
Initial and repeated customer direct or referred troubles reported within a calendar month per 100 lines/ circuits in service.	
Exclusions:	
<ul style="list-style-type: none"> • Trouble tickets canceled at the CLEC request. • BST trouble reports associated with administrative service. • Customer provided Equipment (CPE) troubles or CLEC equipment troubles. 	
Business Rules:	
Customer Trouble Report Rate is computed by accumulating the number of maintenance initial and repeated trouble reports during the reporting period. The resulting number of trouble reports are divided by the total “number of service” lines, ports or combination that exist for the CLEC’s and BST respectively at the end of the report month.	
Calculation:	
Customer Trouble Report Rate = (Count of Initial and Repeated Trouble Reports in the Current Period) / (Number of Service Access Lines in service at End of the Report Period) X 100	
Report Structure:	
<ul style="list-style-type: none"> • CLEC Specific • CLEC Aggregate • BST Aggregate 	
Data Retained Relating to CLEC Experience	Data Retained Relating to BST Experience
<ul style="list-style-type: none"> • Report Month • CLEC Company Name • Ticket Submission Date & Time (TICKET_ID) • Ticket Completion Date (CMLPTN_DT) • Service Type (CLASS_SVC_DESC) • Disposition and Cause (CAUSE_CD & CAUSE_DESC) • # Service Access Lines in Service at the end of period • Geographic Scope 	<ul style="list-style-type: none"> • Report Month • BST Company Code • Ticket Submission Date & Time • Ticket Completion Date • Service Type • Disposition and Cause (Non-Design / Non-Special Only) • Trouble Code (Design and Trunking Services) • # Service Access Lines in Service at the end of period • Geographic Scope
NOTE: Code in parentheses is the corresponding header found in the raw data file.	
Retail Analog/Benchmark:	
CLEC Residence-Resale / BST Residence -Retail CLEC Business-Resale / BST Business-Retail CLEC Design-Resale / BST Design-Retail CLEC PBX, Centrex and ISDN Resale/ BST PBX, Centrex, and ISDN Retail CLEC Trunking-Resale / BST Trunking-Retail UNEs – (See Appendix D)	

Revision Date: 02/22/00 (see)

MAINTENANCE & REPAIR

Report/Measurement:	
M&R-3. Maintenance Average Duration	
Definition:	
The Average duration of Customer Trouble Reports from the receipt of the Customer Trouble Report to the time the trouble report is cleared.	
Exclusions:	
<ul style="list-style-type: none"> • Trouble reports canceled at the CLEC request • BST trouble reports associated with administrative service • Customer Provided Equipment (CPE) troubles or CLEC Equipment Troubles. • Trouble reports greater than 10 days 	
Business Rules:	
For Average Duration the clock starts on the date and time of the receipt of a correct repair request. The clock stops on the date and time the service is restored and the customer notified (when the technician completes the trouble ticket on his/her CAT or work system).	
NOTE: Customer can be BST or CLEC	
Calculation:	
Maintenance Average Duration = $\Sigma(\text{Date and Time of Service Restoration}) - (\text{Date and Time Trouble Ticket was Opened}) / \Sigma(\text{Total Closed Troubles in the reporting period})$	
Report Structure:	
<ul style="list-style-type: none"> • CLEC Specific • BST Aggregate • CLEC Aggregate 	
Data Retained Relating to CLEC Experience	Data Retained Relating to BST Experience
<ul style="list-style-type: none"> • Report Month • Total Tickets (LINE_NBR) • CLEC Company Name • Ticket Submission Date & Time (TIME_ID) • Ticket Completion Date (CMPLTN_DT) • Service Type (CLASS_SVC_DESC) • Disposition and Cause (CAUSE_CD & CAUSE_DESC) • Geographic Scope 	<ul style="list-style-type: none"> • Report Month • Total Tickets • BST Company Code • Ticket Submission Date • Ticket submission Time • Ticket completion Date • Ticket Completion Time • Total Duration Time • Service Type • Disposition and Cause (Non – Design /Non-Special Only) • Trouble Code (Design and Trunking Services) • Geographic Scope
NOTE: Code in parentheses is the corresponding header found in the raw data file.	
Retail Analog/Benchmark:	
CLEC Residence-Resale / BST Residence-Resale CLEC Business-Resale / BST Business-Retail CLEC Design-Resale / BST Design-Retail CLEC PBX, Centrex and ISDN Resale / BST PBX, Centrex and ISDN Retail CLEC Trunking-Resale /BST Trunking-Retail UNEs – (See Appendix D)	

Revision Date: 02/22/00 (see)

MAINTENANCE & REPAIR

Report/Measurement:	
M&R-4. Percent Repeat Troubles within 30 Days	
Definition:	
Trouble reports on the same line/circuit as a previous trouble report received within 30 calendar days as a percent of total troubles reported.	
Exclusions:	
<ul style="list-style-type: none"> • Trouble Reports canceled at the CLEC request • BST Trouble Reports associated with administrative service • Customer Provided Equipment (CPE) Troubles or CLEC Equipment Troubles. 	
Business Rules:	
Includes Customer trouble reports received within 30 days of an original Customer trouble report.	
Calculation:	
Percent Repeat Troubles within 30 Days = (Count of Customer Troubles where more than one trouble report was logged for the same service line within a continuous 30 days) / (Total Trouble Reports Closed in Reporting Period) X 100	
Report Structure:	
<ul style="list-style-type: none"> • CLEC Specific • CLEC Aggregate • BST Aggregate 	
Data Retained Relating to CLEC Experience	Data Retained Relating to BST Experience
<ul style="list-style-type: none"> • Report Month • Total Tickets (LINE_NBR) • CLEC Company Name • Ticket Submission Date & Time (TICKET_ID) • Ticket Completion Date (CMPLTN_DT) • Total and Percent Repeat Trouble Reports within 30 Days (TOT_REPEAT) • Service Type • Disposition and Cause (CAUSE_CD & CAUSE_DESC) • Geographic Scope <p>NOTE: Code parentheses is the corresponding header format found in the raw data file.</p>	<ul style="list-style-type: none"> • Report Month • Total Tickets • BST Company Code • Ticket Submission Date • Ticket Submission Time • Ticket Completion Date • Ticket Completion Time • Total and Percent Repeat Trouble Reports within 30 Days • Service Type • Disposition and Cause (Non – Design/Non-Special only) • Trouble Code (Design and Trunking Services) • Geographic Scope
Retail Analog/Benchmark:	
CLEC Residence-Resale / BST Residence-Retail CLEC Business- Resale / BST Business-Retail CLEC Design-Resale / BST Design-Retail CLEC PBX, Centrex and ISDN Resale / BST PBX, Centrex and ISDN Retail CLEC Trunking-Resale / BST Trunking-Retail UNEs – Retail Analog (See Appendix D)	

Revision date: 02/22/00 (see)

MANTENANCE & REPAIR

Report/Measurement:	
M&R-5. Out of Service (OOS) > 24 Hours	
Definition:	
For Out of Service Troubles (no dial tone, cannot be called or cannot call out) the percentage of troubles cleared in excess of 24 hours. (All design services are considered to be out of service).	
Exclusions:	
<ul style="list-style-type: none"> • Trouble Reports canceled at the CLEC request • BST Trouble Reports associated with administrative service • Customer Provided Equipment (CPE) Troubles or CLEC Equipment Troubles. 	
Business Rules:	
Customer Trouble reports that are out of service and cleared in excess of 24 hours. The clock begins when the trouble report is created in LMOS and the trouble is counted if the time exceeds 24 hours.	
Calculation:	
Out of Service (OOS) > 24 hours = (Total Troubles OOS > 24 Hours) / Total OOS Troubles in Reporting Period) X 100	
Report Structure:	
<ul style="list-style-type: none"> • CLEC Specific • BST Aggregate • CLEC Aggregate 	
Data Retained Relating to CLEC Experience	Data Retained Relating to BST Experience
<ul style="list-style-type: none"> • Report Month • Total Tickets • CLEC Company Name • Ticket Submission Date & Time (TICKET_ID) • Ticket Completion Date (CMPLTN_DT) • Percentage of Customer Troubles out of Service > 24 Hours (OOS>24_FLAG) • Service type (CLASS_SVC_DESC) • Disposition and Cause (CAUSE_CD & CAUSE-DESC) • Geographic Scope <p>NOTE: Code in parentheses is the corresponding header found in the raw data file.</p>	<ul style="list-style-type: none"> • Report Month • Total Tickets • BST Company Code • Ticket Submission Date • Ticket Submission time • Ticket Completion Date • Ticket Completion Time • Percent of Customer Troubles out of Service > 24 Hours • Service type • Disposition and Cause (Non – Design/Non-Special only) • Trouble Code (Design and Trunking Services) • Geographic Scope
Retail Analog/Benchmark:	
CLEC Residence-Resale / BST Residence- Retail CLEC Business- Resale / BST Business-Retail CLEC Design-Resale / BST Design-Retail CLEC PBX, Centrex and ISDN Resale / BST PBX, Centrex and ISDN Retail CLEC Trunking-Resale /BST Trunking- Retail UNEs Retail Analog – (See Appendix D)	

Revision Date: 02/22/00 (see)

MAINTENANCE & REPAIR

Report/Measurement:	
M&R-6. Average Answer Time – Repair Centers	
Definition:	
This measures the average time a customers is in Que.	
Exclusions:	
None	
Business Rules:	
This measure is designed to measure the time required for CLEC & BST from the time of the ACD choice to the time of being answered. The clock starts when the CLEC Rep makes a choice to be put in queue for the next repair attendant and the clock stops when the repair attendant answers the call.	
(NOTE: The Column is a combined BST Residence and Business number)	
Level of Disaggregation:	
Region. CLEC/BST Service Centers and BST Repair Centers are regional.	
Calculation:	
Average Answer Time for BST’s Repair Centers = (Time BST Repair Attendant Answers Call) – (Time of entry into queue until ACD Selection) / (Total number of calls by reporting period)	
Report Structure:	
<ul style="list-style-type: none"> • CLEC Aggregate • BST Aggregate 	
Data Retained Relating to CLEC Experience	Data Retained Relating to BST Experience
<ul style="list-style-type: none"> • CLEC Average Answer Time 	<ul style="list-style-type: none"> • BST Average Answer Time
Retail Analog/Benchmark:	
For CLEC, Average Answer Times in UNE Center and BRMC are comparable to the Average Answer Times in the BST Repair Centers. See Appendix D	

Revision Date: 02/22/00 (see)

BILLING

Report/Measurement:	
B-1. Invoice Accuracy	
Definition:	
This measure provides the percentage of accuracy of the billing invoices rendered to CLECs during the current month.	
Exclusions:	
<ul style="list-style-type: none"> Adjustments not related to billing errors (e.g., credits for service outage, special promotion credits, adjustments to satisfy the customer) 	
Business Rules:	
The accuracy of billing invoices delivered by BST to the CLEC must enable them to provide a degree of billing accuracy comparative to BST bills rendered to retail customers BST. CLECs request adjustments on bills determined to be incorrect. The BellSouth Billing verification process includes manually analyzing a sample of local bills from each bill period. The bill verification process draws from a mix of different customer billing options and types of service. An end-to-end auditing process is performed for new products and services. Internal measurements and controls are maintained on all billing processes.	
Calculation:	
$\text{Invoice Accuracy} = \frac{(\text{Total Billed Revenues during current month}) - (\text{Billing Related Adjustments during current month})}{\text{Total Billed Revenues during current month}} \times 100$	
Report Structure:	
<ul style="list-style-type: none"> CLEC Specific CLEC Aggregate BST Aggregate 	
Level of Disaggregation :	
<ul style="list-style-type: none"> Product / Invoice Type <ul style="list-style-type: none"> ➢ Resale ➢ UNE ➢ Interconnection Geographic Scope <ul style="list-style-type: none"> ➢ Region 	
Data Retained Relating to CLEC Experience:	Data Retained Relating to BST Performance:
<ul style="list-style-type: none"> Report Month Invoice Type Total Billed Revenue Billing Related Adjustments 	<ul style="list-style-type: none"> Report Month Retail Type <ul style="list-style-type: none"> ➢ CRIS ➢ CABS Total Billed Revenue Billing Related Adjustments
Retail Analog/Benchmark	
CLEC Invoice Accuracy is comparable to BST Invoice Accuracy See Appendix D	

Revision Date: 02/28/00 (dg)

BILLING

Report/Measurement:	
B-2. Mean Time to Deliver Invoices	
Definition:	
This measure provides the mean interval for billing invoices	
Exclusions:	
Any invoices rejected due to formatting or content errors.	
Business Rules:	
Measures the mean interval for timeliness of billing records delivered to CLECs in an agreed upon format. CRIS-based invoices are measured in business days, and CABS-based invoices in calendar days.	
Calculation:	
Mean Time To Deliver Invoices = $\Sigma_{[(Invoice\ Transmission\ Date) - (Close\ Date\ of\ Scheduled\ Bill\ Cycle)]} / (\text{Count of Invoices Transmitted in Reporting Period})$	
Report Structure:	
<ul style="list-style-type: none"> • CLEC Specific • CLEC Aggregate • BST Aggregate 	
Level of Disaggregation:	
<ul style="list-style-type: none"> • Product / Invoice Type <ul style="list-style-type: none"> ➢ Resale ➢ UNE ➢ Interconnection • Geographic Scope <ul style="list-style-type: none"> ➢ Region 	
Data Retained Relating to CLEC Experience:	Data Retained Relating to BST Performance:
<ul style="list-style-type: none"> • Report Month • Invoice Type • Invoice Transmission Count • Date of Scheduled Bill Close 	<ul style="list-style-type: none"> • Report Month • Retail Type <ul style="list-style-type: none"> ➢ CRIS ➢ CABS • Invoice Transmission Count • Date of Scheduled Bill Close
Retail Analog/Benchmark:	
<p>CRIS-based invoices will be released for delivery within six (6) business days CABS-based invoices will be released for delivery within eight (8) calendar days. CLEC Average Delivery Intervals for both CRIS and CABS Invoices are comparable to BST Average delivery for both systems. See Appendix D</p>	

Revision Date: 02/28/00 (dg)

BILLING

Report/Measurement:	
B-3. Usage Data Delivery Accuracy	
Definition:	
This measurement captures the percentage of recorded usage that is delivered error free and in an acceptable format to the appropriate Competitive Local Exchange Carrier (CLEC). These percentages will provide the necessary data for use as a comparative measurement for BellSouth performance. This measurement captures Data Delivery Accuracy rather than the accuracy of the individual usage recording.	
Exclusions:	
None	
Business Rules:	
The accuracy of the data delivery of usage records delivered by BST to the CLEC must enable them to provide a degree of accuracy comparative to BST bills rendered to their retail customers. If errors are detected in the delivery process, they are investigated, evaluated and documented. Errors are corrected and the data retransmitted to the CLEC.	
Calculations:	
Usage Data Delivery Accuracy = $\Sigma[(\text{Total number of usage data packs sent during current month}) - (\text{Total number of usage data packs requiring retransmission during current month})] / (\text{Total number of usage data packs sent during current month}) \times 100$	
Report Structure:	
<ul style="list-style-type: none"> • CLEC Specific • CLEC Aggregate • BST Aggregate 	
Level of Disaggregation:	
<ul style="list-style-type: none"> • Geographic Scope <ul style="list-style-type: none"> ➢ Region 	
Data Retained Relating to CLEC Experience:	Data Retained Relating to BST Performance:
<ul style="list-style-type: none"> • Report Month • Record Type <ul style="list-style-type: none"> ➢ BellSouth Recorded ➢ Non BellSouth Recorded 	<ul style="list-style-type: none"> • Report Month • Record Type
Retail Analog/Benchmark:	
CLEC Usage Data Delivery Accuracy is comparable to BST Usage Data Delivery Accuracy See Appendix D	

Revision Date: 02/28/00 (dg)

BILLING

Report/Measurement:	
B-4. Usage Data Delivery Completeness	
Definition:	
This measurement provides percentage of complete and accurately recorded usage data (usage recorded by BellSouth and usage recorded by other companies and sent to BST for billing) that is processed and transmitted to the CLEC within thirty (30) days of the message recording date. A parity measure is also provided showing completeness of BST messages processed and transmitted via CMDS. BellSouth delivers its own retail usage from recording location to billing location via CMDS as well as delivering billing data to other companies. Timeliness, Completeness and Mean Time to Deliver Usage measures are reported on the same report.	
Exclusions:	
None	
Business Rules:	
The purpose of these measurements is to demonstrate the level of quality of usage data delivered to the appropriate CLEC. Method of delivery is at the option of the CLEC.	
Calculation:	
Usage Data Delivery Completeness = $\frac{\Sigma(\text{Total number of Recorded usage records delivered during the current month that are within thirty (30) days of the message recording date})}{\Sigma(\text{Total number of Recorded usage records delivered during the current month})} \times 100$	
Report Structure	
<ul style="list-style-type: none"> • CLEC Specific • CLEC Aggregate • BST Aggregate 	
Level of Disaggregation:	
<ul style="list-style-type: none"> • Geographic Scope <ul style="list-style-type: none"> ➢ Region 	
Data Retained Relating to CLEC Experience:	Data Retained Relating to BST Performance:
<ul style="list-style-type: none"> • Report Month • Record Type <ul style="list-style-type: none"> ➢ BellSouth Recorded ➢ Non BellSouth Recorded 	<ul style="list-style-type: none"> • Report Monthly • Record Type
Retail Analog/Benchmark:	
CLEC Usage Delivery Completeness is comparable to BST Usage Delivery Completeness See Appendix D	

Revision Date: 02/28/00 (dg)

BILLING

Report/Measurement:	
B-5. Usage Data Delivery Timeliness	
Definition:	
This measurement provides a percentage of recorded usage data (usage recorded by BST and usage recorded by other companies and sent to BST for billing) that is delivered to the appropriate CLEC within six (6) calendar days from the receipt of the initial recording. A parity measure is also provided showing timeliness of BST messages processed and transmitted via CMDS. Timeliness, Completeness and Mean Time to Deliver Usage measures are reported on the same report.	
Exclusions:	
None	
Business Rules:	
The purpose of this measurement is to demonstrate the level of timeliness for processing and transmission of usage data delivered to the appropriate CLEC. The usage data will be mechanically transmitted or mailed to the CLEC data processing center once daily. The Timeliness interval of usage recorded by other companies is measured from the date BST receives the records to the date BST distributes to the CLEC. Method of delivery is at the option of the CLEC.	
Calculation:	
Usage Data Delivery Timeliness = $\Sigma(\text{Total number of usage records sent within six (6) calendar days from initial recording/receipt}) / \Sigma(\text{Total number of usage records sent}) \times 100$	
Report Structure:	
<ul style="list-style-type: none"> • CLEC Aggregate • CLEC Specific • BST Aggregate 	
Level of Disaggregation:	
<ul style="list-style-type: none"> • Geographic Scope <ul style="list-style-type: none"> ➢ Region 	
Data Retained Relating to CLEC Experience:	Data Retained Relating to BST Performance:
<ul style="list-style-type: none"> • Report Month • Record Type <ul style="list-style-type: none"> ➢ BellSouth Recorded ➢ Non-BellSouth Recorded 	<ul style="list-style-type: none"> • Report Monthly • Record Type
Retail Analog/Benchmark:	
CLEC Usage Data Delivery Timeliness is comparable to BST Usage Data Delivery Timeliness See Appendix D	

Revision date: 02/28/00 (dg)

BILLING

Report/Measurement:	
B-6. Mean Time to Deliver Usage	
Definition:	
This measurement provides the average time it takes to deliver Usage Records to a CLEC. A parity measure is also provided showing timeliness of BST messages processed and transmitted via CMDS. Timeliness, Completeness and Mean Time to Deliver Usage measures are reported on the same report.	
Exclusions:	
None	
Business Rules:	
The purpose of this measurement is to demonstrate the average number of days it takes BST to deliver Usage data to the appropriate CLEC. Usage data is mechanically transmitted or mailed to the CLEC data processing center once daily. Method of delivery is at the option of the CLEC.	
Calculation:	
Mean Time to Deliver Usage = Σ _(Record volume X estimated number of days to deliver the Usage Record) / total record volume	
Report Structure:	
<ul style="list-style-type: none"> • CLEC Aggregate • CLEC Specific • BST Aggregate 	
Level of Disaggregation:	
<ul style="list-style-type: none"> • Geographic Scope <ul style="list-style-type: none"> ➢ Region 	
Data Retained Relating to CLEC Experience:	Data Retained Relating to BST Performance:
<ul style="list-style-type: none"> • Report Month • Record Type <ul style="list-style-type: none"> ➢ BellSouth Recorded ➢ Non-BellSouth Recorded 	<ul style="list-style-type: none"> • Report Monthly • Record Type
Retail Analog/Benchmark:	
Mean Time to Deliver Usage to CLEC is comparable to Mean Time to Deliver Usage to BST See Appendix D	

Revision Date: 02/28/00 (dg)

OPERATOR SERVICES

Report/Measurement:
OS-1. Speed to Answer Performance/Average Speed to Answer – Toll
Definition:
Measurement of the average time in seconds calls wait before answered by a toll operator.
Exclusions:
Calls abandoned by customers are not reflected in the average speed to answer but are reflected in the conversion tables where the percent answered within “X” seconds is determined.
Business Rules:
The call waiting measurement scan starts when the customer enters the queue and ends when a BST representative answers the call. The average speed to answer is determined by measuring and accumulating the seconds of wait time from the entry of a customer into the BST call management system queue until the customer is transferred to a BST representative. No distinction is made between CLEC customers and BST customers.
Calculation:
The Average Speed to Answer for toll is calculated by using data from monthly system measurement reports taken from the centralized call routing switches. The “total call waiting seconds” is a sub-component of this measure which BST systems calculate by monitoring the number of calls in queue throughout the day multiplied by the time (in seconds) between monitoring events. The “total calls served” is the other sub-component of this measure, which BST systems record as the total number of calls handled by Operator Services toll centers. Since calls abandoned are not reflected in the calculation, the percent answered within the required timeframe is determined by using conversion tables with input for the abandonment rate.
Report Structure:
<ul style="list-style-type: none"> • Reported for the aggregate of BST and CLECs <ul style="list-style-type: none"> ➤ State
Level of Disaggregation:
None
Data Retained (on Aggregate Basis)
For the items below, BST’s Performance Measurement Analysis Platform (PMAP) receives a final computation; therefore, no raw data file is available in PMAP. <ul style="list-style-type: none"> • Month • Call Type (Toll) • Average Speed of Answer
Retail Analog/Benchmark
Parity by Design See Appendix D

Revision Date:02/28/00 (tg)

OPERATOR SERVICES

Report/Measurement:
OS-2. Speed to Answer Performance/Percent Answered within “X” Seconds – Toll
Definition:
Measurement of the percent of toll calls that are answered in less than “X” seconds. The number of seconds represented by “X” is thirty, except where a different regulatory benchmark has been set against the Average Speed to Answer by a State Commission.
Exclusions:
Calls abandoned by customers are not reflected in the average speed to answer but are reflected in the conversion tables where the percent answered within “X” seconds is determined.
Business Rules:
The call waiting measurement scan starts when the customer enters the queue and ends when a BST representative answers the call. The average speed to answer is determined by measuring and accumulating the seconds of wait time from the entry of a customer into the BST call management system queue until the customer is transferred to a BST representative. No distinction is made between CLEC customers and BST customers.
Calculation:
The Percent Answered within “X” Seconds measurement for toll is derived by using the BellCore Statistical Answer Conversion Tables, to convert the Average Speed to Answer measure into a percent of calls answered within “X” seconds. The BellCore Conversion Tables are specific to the defined parameters of work time, number of operators, max queue size and call abandonment rates.
Report Structure:
<ul style="list-style-type: none"> • Reported for the aggregate of BST and CLECs <ul style="list-style-type: none"> ➤ State
Level of Disaggregation:
None
Data Retained (on Aggregate Basis)
For the items below, BST’s Performance Measurement Analysis Platform (PMAP) receives a final computation; therefore, no raw data file is available in PMAP. <ul style="list-style-type: none"> • Month • Call Type (Toll) • Average Speed of Answer
Retail Analog/Benchmark
Parity by Design See Appendix D

Revision Date:02/28/00 (tg)

OPERATOR SERVICES

Report/Measurement:
OS-3. Speed to Answer Performance/Average Speed to Answer – Directory Assistance (DA)
Definition:
Measurement of the average time in seconds calls wait before answer by a DA operator.
Exclusions:
Calls abandoned by customers are not reflected in the average speed to answer but are reflected in the conversion tables where the percent answered within “X” seconds is determined.
Business Rules:
The call waiting measurement scan starts when the customer enters the queue and ends when a BST representative answers the call. The average speed to answer is determined by measuring and accumulating the seconds of wait time from the entry of a customer into the BST call management system queue until the customer is transferred to a BST representative. No distinction is made between CLEC customers and BST customers.
Calculation:
The Average Speed to Answer for DA is calculated by using data from monthly system measurement reports taken from the centralized call routing switches. The “total call waiting seconds” is a sub-component of this measure which BST systems calculate by monitoring the number of calls in queue throughout the day multiplied by the time (in seconds) between monitoring events. The “total calls served” is the other sub-component of this measure, which BST systems record as the total number of calls handled by Operator Services DA centers. Since calls abandoned are not reflected in the calculation, the percent answered within the required timeframe is determined by using conversion tables with input for the abandonment rate.
Report Structure:
<ul style="list-style-type: none"> • Reported for the aggregate of BST and CLECs <ul style="list-style-type: none"> ➤ State
Level of Disaggregation:
None
Data Retained (on Aggregate Basis)
For the items below, BST’s Performance Measurement Analysis Platform (PMAP) receives a final computation; therefore, no raw data file is available in PMAP. <ul style="list-style-type: none"> • Month • Call Type (DA) • Average Speed of Answer
Retail Analog/Benchmark
Parity by Design See Appendix D

Revision Date:02/28/00 (tg)

OPERATOR SERVICES

Report/Measurement:
OS-4. Speed to Answer Performance/Percent Answered within “X” Seconds – Directory Assistance (DA)
Definition:
Measurement of the percent of DA calls that are answered in less than “X” seconds. The number of seconds represented by “X” is twenty, except where a different regulatory benchmark has been set against the Average Speed to Answer by a State Commission.
Exclusions:
Calls abandoned by customers are not reflected in the average speed to answer but are reflected in the conversion tables where the percent answered within “X” seconds is determined.
Business Rules:
The call waiting measurement scan starts when the customer enters the queue and ends when a BST representative answers the call. The average speed to answer is determined by measuring and accumulating the seconds of wait time from the entry of a customer into the BST call management system queue until the customer is transferred to a BST representative. No distinction is made between CLEC customers and BST customers.
Calculation:
The Percent Answered within “X” Seconds measurement for DA is derived by using the BellCore Statistical Answer Conversion Tables, to convert the Average Speed to Answer measure into a percent of calls answered within “X” seconds. The BellCore Conversion Tables are specific to the defined parameters of work time, number of operators, max queue size and call abandonment rates.
Report Structure:
<ul style="list-style-type: none"> • Reported for the aggregate of BST and CLECs <ul style="list-style-type: none"> ➤ State
Level of Disaggregation:
None
Data Retained (on Aggregate Basis)
For the items below, BST’s Performance Measurement Analysis Platform (PMAP) receives a final computation; therefore, no raw data file is available in PMAP. <ul style="list-style-type: none"> • Month • Call Type (DA) • Average Speed of Answer
Retail Analog/Benchmark
Parity by Design See Appendix D

Revision Date:02/28/00 (tg)

E911

Report/Measurement:
E-1. Timeliness
Definition:
Measures the percentage of batch orders for E911 database updates (to CLEC resale and BST retail records) processed successfully within a 24-hour period.
Exclusions:
<ul style="list-style-type: none"> • Any resale order canceled by a CLEC • Facilities-based CLEC orders
Business Rules:
The 24-hour processing period is calculated based on the date and time processing starts on the batch orders and the date and time processing stops on the batch orders. Mechanical processing starts when SCC (BST's E911 vendor) receives E911 files containing batch orders extracted from BST's Service Order Communication System (SOCS). Processing stops when SCC loads the individual records to the E911 database. No distinctions are made between CLEC resale records and BST retail records.
Calculation:
$E911 \text{ Timeliness} = \Sigma (\text{Number of batch orders processed within 24 hours} \div \text{Total number of batch orders submitted}) \times 100$
Report Structure:
<ul style="list-style-type: none"> • Reported for the aggregate of CLEC resale updates and BST retail updates <ul style="list-style-type: none"> ➢ State ➢ Region
Levels of Disaggregation:
None
Data Retained
<ul style="list-style-type: none"> • Report month • Aggregate data
Retail Analog/Benchmark
Parity by Design See Appendix D

Revision Date:02/28/00 (tg)

E911

Report/Measurement:
E-2. Accuracy
Definition:
Measures the individual E911 telephone number (TN) record updates (to CLEC resale and BST retail records) processed successfully for E911 with no errors.
Exclusions:
<ul style="list-style-type: none"> • Any resale order canceled by a CLEC • Facilities-based CLEC orders
Business Rules:
Accuracy is based on the number of records processed without error at the conclusion of the processing cycle. Mechanical processing starts when SCC (BST's E911 vendor) receives E911 files containing telephone number (TN) records extracted from BST's Service Order Communication System (SOCS). No distinctions are made between CLEC resale records and BST retail records.
Calculation:
$E911 \text{ Accuracy} = \frac{\Sigma(\text{Number of record individual updates processed with no errors}}{\text{Total number of individual record updates}} \times 100$
Report Structure:
<ul style="list-style-type: none"> • Reported for the aggregate of CLEC resale updates and BST retail updates <ul style="list-style-type: none"> ➢ State ➢ Region
Level of Disaggregation:
None
Data Retained
<ul style="list-style-type: none"> • Report month • Aggregate data
Retail Analog/Benchmark
Parity by Design See Appendix D

Revision Date:02/28/00 (tg)

E911

Report/Measurement:
E-3. Mean Interval
Definition:
Measures the mean interval processing of E911 batch orders (to update CLEC resale and BST retail records).
Exclusions:
<ul style="list-style-type: none"> • Any resale order canceled by a CLEC • Facilities-based CLEC orders
Business Rules:
The processing period is calculated based on the date and time processing starts on the batch orders and the date and time processing stops on the batch orders. Data is posted in 4-hour increments up to and beyond 24 hours. No distinctions are made between CLEC resale records and BST retail records.
Calculation:
$\text{E911 Mean Interval} = \frac{\sum (\text{Date and time of batch order completion} - \text{Date and time of batch order submission})}{\text{Number of batch orders completed}}$
Report Structure:
<ul style="list-style-type: none"> • Reported for the aggregate of CLEC resale updates and BST retail updates <ul style="list-style-type: none"> ➢ State ➢ Region
Level of Disaggregation:
None
Data Retained (on Aggregate Basis)
<ul style="list-style-type: none"> • Report month • Aggregate data
Retail Analog/Benchmark
Parity by Design See Appendix D

Revision Date:02/28/00 (tg)

TRUNK GROUP PERFORMANCE

Report/Measurement:	
TGP-1. Trunk Group Performance-Aggregate	
Definition:	
A report of aggregate blocking information for CLEC trunk groups and BellSouth trunk groups.	
Exclusions:	
<ul style="list-style-type: none"> • Trunk Groups for which valid data is not available for an entire study period • Duplicate trunk group information 	
Business Rules:	
<ul style="list-style-type: none"> • Aggregate blocking results are created using the statistical analysis package and are output into Excel with separate table for each geographic area. • For each geographic area, plots are generated for: a) the monthly blocking by hour for each affecting group (BellSouth or CLEC), and b) the difference between BellSouth blocking data and CLEC blocking data is calculated and plotted. • The TCBH blocking is calculated by determining the monthly averaging blocking for each hour for each trunk. The hour with the highest usage is selected as the TCBH and the blocking for that hour is reported. • Trunk Categorization: This report displays, over a reporting cycle, aggregate, weighted average blocking data for each hour of a day. Therefore, for each reporting cycle, 24 blocking data points are generated for two aggregate groups of selected trunk groups. These groups are CLEC affecting and BellSouth affecting trunk groups. In order to assign trunk groups to each aggregate group, all trunk groups are first assigned to a category. A trunk group's end points and the type of traffic that is transmitted on it define a category. Selected categories of trunk groups are assigned to the aggregate groups to that trunk reports can be generated. The categories to which trunk groups have been assigned for this report are as follows: 	
CLEC Affecting Categories:	
	<u>Point A</u>
Category 1:	BellSouth End Office
Category 3:	BellSouth End Office
Category 4:	BellSouth Local Tandem
Category 5:	BellSouth Access Tandem
Category 10:	BellSouth End Office
Category 16:	BellSouth Tandem
	<u>Point B</u>
	BellSouth Access Tandem
	CLEC Switch
	CLEC Switch
	CLEC Switch
	BellSouth Local Tandem
	BellSouth Tandem
BellSouth Affecting Category:	
	<u>Point A</u>
Category 9:	BellSouth End Office
	<u>Point B</u>
	BellSouth End Office

TRUNK GROUP PERFORMANCE - (Trunk Group Performance-Aggregate – Continued)

Calculation:

Monthly Weighted Average Blocking:

(Blocking data for each hour X number of valid measurement days within each week) / Σ (Total number of valid measurement days within each week)

Example:		<u>Week 1</u>	<u>Week 2</u>	<u>Week 3</u>	<u>Week 4</u>	<u>Monthly</u>
Hour						
1	Blocking	1%	0.5%	2%	1.5%	1.8%
	# Days	7	7	5	6	
2	Blocking	0%	0%	0.2%	0.3%	.1%
	# Days	7	5	5	7	
3	Blocking	1%	1%	0.5%	2%	1.1%
	# Days	7	7	7	7	
24	Blocking	1%	0.5%	2%	1.5%	1.2%
	# Days	7	7	5	6	

The monthly weighted average blocking for hour 1 for a particular trunk group is calculated as follows:

$$\frac{(1 \times 5) + (0.5 \times 5) + (2 \times 4) + (1.5 \times 4)}{(5 + 5 + 4 + 4)} = 1.2\%$$

Aggregate Monthly Blocking:

(Monthly weighted average blocking value for each trunk group) X (number of trunks within each trunk group) / Σ (number of trunks in the aggregate group)

Example:	Trunk Group	Trunks in Service	Blocking Hour 1	Blocking Hour 2	Blocking Hour 3	Blocking Hour 4	Blocking Hour 24
	A	24	3%	0%	1%	0%		0%
	B	144	2%	0%	1%	0.5%		0.5%
	C	528	0%	0.5%	1%	1%		1%
	D	316	1%	0%	1%	0.1%		0%
	E	940	1%	1%	4%	0%		0%
	Aggregate		0.8%	0.6%	2.4%	0.3%		0.3%

The aggregate weighted monthly blocking for hour 1 is calculated as follows:

$$\frac{(3 \times 24) + (2 \times 144) + (0 \times 528) + (1 \times 316) + (1 \times 940)}{(24 + 144 + 528 + 316 + 940)} = 0.8\%$$

The purpose of the Trunk Group Performance Report is to provide trunk blocking measurements on CLEC and BST trunk groups for comparison only. It is not the intent of the report that it be used for network management and/or engineering.

Report Structure:

- CLEC Aggregate
 - State

Level of Disaggregation:

Trunk Group

Data Retained Relating to CLEC Experience

- Report Month
- Total Trunk Groups
- Number of Trunk Groups by CLEC
- Hourly average blocking per trunk group

Data Retained Relating to BST Experience

- Report Month
- Total Trunk Groups
- Aggregate Hourly average blocking

Retail Analog/Benchmark:

Any 2 hour period in 24 hours where CLEC blockage exceeds BST blockage by more than 0.5% = a miss using trunk groups 1, 3, 4, 5, 10, 16 for CLECs and 9 for BST.

Revision Date: 02/28/00 (tm)

TRUNK GROUP PERFORMANCE

Report/Measurement:		
TGP-2. Trunk Group Performance-CLEC Specific		
Definition:		
A report of blocking information for CLEC trunk groups.		
Exclusions:		
<ul style="list-style-type: none"> • Trunk Groups for which valid data is not available for an entire study period • Duplicate trunk group information 		
Business Rules:		
<ul style="list-style-type: none"> • Aggregate blocking results are created using the statistical analysis package and are output into Excel with separate table for each geographic area. • For each geographic area, plots are generated for the monthly blocking by hour • The TCBH blocking is calculated by determining the monthly averaging blocking for each hour for each trunk. The hour with the highest usage is selected as the TCBH and the blocking for that hour is reported. • Trunk Categorization: This report displays, over a reporting cycle, aggregate, weighted average blocking data for each hour of a day. Therefore, for each reporting cycle, 24 blocking data points are generated for CLEC trunk groups. In order to assign trunk groups to the CLEC group, all trunk groups are first assigned to a category. A trunk group's end points and the type of traffic that is transmitted on it define a category. Selected categories of trunk groups are assigned to the aggregate groups to that trunk reports can be generated. The categories to which trunk groups have been assigned for this report are as follows: 		
CLEC Affecting Categories:		
	<u>Point A</u>	
<u>Point B</u>		
Category 1:	BellSouth End Office	BellSouth Access Tandem
Category 3:	BellSouth End Office	CLEC Switch
Category 4:	BellSouth Local Tandem	CLEC Switch
Category 5:	BellSouth Access Tandem	CLEC Switch
Category 10:	BellSouth End Office	BellSouth Local Tandem
Category 16:	BellSouth Tandem	BellSouth Tandem

TRUNK GROUP PERFORMANCE - (Trunk Group Performance-CLEC Specific – Continued)

Calculation:

Monthly Weighted Average Blocking:

(Blocking data for each hour X number of valid measurement days within each week) / Σ (Total number of valid measurement days within each week)

Example:		<u>Week 1</u>	<u>Week 2</u>	<u>Week 3</u>	<u>Week 4</u>	<u>Monthly</u>
Hour						
1	Blocking	1%	0.5%	2%	1.5%	1.8%
	# Days	7	7	5	6	
2	Blocking	0%	0%	0.2%	0.3%	.1%
	# Days	7	5	5	7	
3	Blocking	1%	1%	0.5%	2%	1.1%
	# Days	7	7	7	7	5
24	Blocking	1%	0.5%	2%	1.5%	1.2%
	# Days	7	7	5	6	

The monthly weighted average blocking for hour 1 for a particular trunk group is calculated as follows:

$$\frac{(1 \times 5) + (0.5 \times 5) + (2 \times 4) + (1.5 \times 4)}{(5 + 5 + 4 + 4)} = 1.2\%$$

Aggregate Monthly Blocking:

(Monthly weighted average blocking value for each trunk group) X (number of trunks within each trunk group) / Σ (number of trunks in the aggregate group)

Example:	Trunk Group	Trunks in Service	Blocking Hour 1	Blocking Hour 2	Blocking Hour 3	Blocking Hour 4	Blocking Hour 24
	A	24	3%	0%	1%	0%		0%
	B	144	2%	0%	1%	0.5%		0.5%
	C	528	0%	0.5%	1%	1%		1%
	D	316	1%	0%	1%	0.1%		0%
	E	940	1%	1%	4%	0%		0%
	Aggregate		0.8%	0.6%	2.4%	0.3%		0.3%

The aggregate weighted monthly blocking for hour 1 is calculated as follows:

$$\frac{(3 \times 24) + (2 \times 144) + (0 \times 528) + (1 \times 316) + (1 \times 940)}{(24 + 144 + 528 + 316 + 940)} = 0.8\%$$

The purpose of the Trunk Group Performance Report is to provide trunk blocking measurements on CLEC and BST trunk groups for comparison only. It is not the intent of the report that it be used for network management and/or engineering.

Report Structure:

- CLEC Specific
- Trunk Group

Level of Disaggregation:

Trunk Group

Data Retained Relating to CLEC Experience

- Report Month
- Total Trunk Groups
- Number of Trunk Groups by CLEC
- Hourly average blocking per trunk group

Data Retained Relating to BST Experience

- Report Month
- Total Trunk Groups
- Aggregate Hourly average blocking

Retail Analog/Benchmark:

Any 2 hour period in 24 hours where CLEC blockage exceeds BST blockage by more than 0.5% = a miss using trunk groups 1, 3, 4, 5, 10, 16 for CLECs and 9 for BST.

Revision Date: 02/28/00 (tm)

TRUNK GROUP PERFORMANCE

Report/Measurement:	
TGP-3. Trunk Group Service Report	
Definition:	
A report of the percent blocking above the Measured Blocking Threshold (MBT) on all final trunk groups between CLEC Points of Termination and BST end offices or tandems.	
Exclusions:	
<ul style="list-style-type: none"> • Trunk groups for which valid traffic data is not available • High use trunk groups 	
Business Rules:	
Traffic trunking data measurements are validated and processed by the Total Network Data System/Trunking (TNDS/TK), a Telcordia (BellCore) supported application, on an hourly basis for Average Business Days (Monday through Friday). The traffic load sets, including offered load and observed blocking ratio (calls blocked divided by calls attempted), are averaged for a 20 day period, and the busy hour is selected. The busy hour average data for each trunk group is captured for reporting purposes. Although all trunk groups are available for reporting, the report highlight those trunk groups with blocking greater than the Measured Blocking Threshold (MBT) and the number of consecutive monthly reports that the trunk group blocking has exceeded the MBT. The MBT for CTTG is 2% and the MBT for all other trunk groups is 3%.	
Calculation:	
Measured blocking = (Total number of blocked calls) / (Total number of attempted calls) X 100	
Report Structure:	
<ul style="list-style-type: none"> • BST Aggregate <ul style="list-style-type: none"> ➢ CTTG ➢ Local • CLEC Aggregate <ul style="list-style-type: none"> ➢ BST Administered CLEC Trunk ➢ CLEC Administered CLEC Trunk • CLEC Specific <ul style="list-style-type: none"> ➢ BST Administered CLEC Trunk ➢ CLEC Administered CLEC Trunk 	
Level of Disaggregation:	
State	
Data Retained Relating to CLEC Experience	Data Retained Relating to BST Experience
<ul style="list-style-type: none"> • Report month • Total trunk groups • Total trunk groups for which data is available • Trunk groups with blocking greater than the MBT • Percent of trunk groups with blocking greater than the MBT 	<ul style="list-style-type: none"> • Report month • Total trunk groups • Total trunk groups for which data is available • Trunk groups with blocking greater than the MBT • Percent of trunk groups with blocking greater than the MBT
Retail Analog/Benchmark:	
CLEC Trunk Blockage/BST Trunk Blockage See Appendix D	

Revision Date: 02/28/00 (tm)

TRUNK GROUP PERFORMANCE

Report/Measurement:	
TGP-4. Trunk Group Service Detail	
Definition:	
A detailed list of all final trunk groups between CLEC Points of Presence and BST end offices or tandems, and the actual blocking performance when the blocking exceeds the Measured Blocking Threshold (MBT) for the trunk groups.	
Exclusions:	
<ul style="list-style-type: none"> • Trunk groups for which valid traffic data is not available • High use trunk groups 	
Business Rules:	
Traffic trunking data measurements are validated and processed by the Total Network Data System/Trunking (TNDS/TK), a Telcordia (Bellcore) supported application, on an hourly basis for Average Business Days (Monday through Friday). The traffic load sets, including offered load and observed blocking ratio (calls blocked divided by calls attempted), are averaged for a 20 day period, and the busy hour is selected. The busy hour average data for each trunk group is captured for reporting purposes. Although all trunk groups are available for reporting, the report highlight those trunk groups with blocking greater than the Measured Blocking Threshold (MBT) and the number of consecutive monthly reports that the trunk group blocking has exceeded the MBT. The MBT for CTTG is 2% and the MBT for all other trunk groups is 3%.	
Calculation:	
Measured Blocking = (Total number of blocked calls) / (Total number of attempted calls) X 100	
Report Structure:	
<ul style="list-style-type: none"> • . BST Specific <ul style="list-style-type: none"> ➢ .Traffic Identity ➢ TGSN ➢ Tandem ➢ End Office ➢ Description ➢ Observed Blocking ➢ Busy Hour ➢ Number Trunks ➢ Valid study days ➢ Number reports ➢ Remarks 	<ul style="list-style-type: none"> • CLEC Specific <ul style="list-style-type: none"> ➢ Traffic Identity ➢ TGSN ➢ Tandem ➢ CLEC POT ➢ Description ➢ Observed Blocking ➢ Busy Hour ➢ Number Trunks ➢ Valid study days ➢ Number reports ➢ Remarks
Level of Disaggregation:	
State	
Data Retained Relating to CLEC Experience	Data Retained Relating to BST Experience
<ul style="list-style-type: none"> • Report month • Total trunk groups • Total trunk groups for which data is available • Trunk groups with blocking greater than the MBT • Percent of trunk groups with blocking greater than the MBT • Traffic identity, TGSN, end points, description, busy hour, valid study days, number reports 	<ul style="list-style-type: none"> • Report month • Total trunk groups • Total trunk groups for which data is available • Trunk groups with blocking greater than the MBT • Percent of trunk groups with blocking greater than the MBT • Traffic identity, TGSN, end points, description, busy hour, valid study days, number reports
Retail Analog/Benchmark:	
CLEC Trunk Blockage/BST Blockage See Appendix D	

Revision Date: 02/28/00 (tm)

COLLOCATION

Report/Measurement:
C-1. Average Response Time
Definition:
Measures the average time (counted in business days) from the receipt of a complete and accurate collocation application (including receipt of application fees) to the date BellSouth responds in writing.
Exclusions:
<ul style="list-style-type: none"> • Requests to augment previously completed arrangements • Any application cancelled by the CLEC
Business Rules:
The clock starts on the date that BST receives a complete and accurate collocation application accompanied by the appropriate application fee. The clock stops on the date that BST returns a response. The clock will restart upon receipt of changes to the original application request.
Calculation:
Average Response Time = $\Sigma(\text{Request Response Date}) - (\text{Request Submission Date}) / \text{Count of Responses Returned within Reporting Period.}$
Report Structure:
<ul style="list-style-type: none"> • Individual CLEC (alias) aggregate • Aggregate of all CLECs
Level of Disaggregation:
<ul style="list-style-type: none"> • State, Region and further geographic disaggregation as required by State Commission Order (e.g. Metropolitan Service Area – MSA) • Virtual • Physical
Data Retained:
<ul style="list-style-type: none"> • Report period • Aggregate data
Retail Analog/Benchmark:
See Appendix D

Revision Date: 01/27/00 (tg)

COLLOCATION

Report/Measurement:
C-2. Average Arrangement Time
Definition:
Measures the average time from the receipt of a complete and accurate Bona Fide firm order (including receipt of appropriate fee) to the date BST completes the collocation arrangement.
Exclusions:
<ul style="list-style-type: none"> • Any Bona Fide firm order cancelled by the CLEC • Bona Fide firm orders to augment previously completed arrangements • Time for BST to obtain permits • Time during which the collocation contract is being negotiated
Business Rules:
The clock starts on the date that BST receives a complete and accurate Bona Fide firm order accompanied by the appropriate fee. The clock stops upon submission of the permit request and restarts upon receipt of the approved permit. Changes (affecting the provisioning interval or capital expenditures) that are submitted while provisioning is in progress may alter the completion date. The clock stops on the date that BST completes the collocation arrangement.
Calculation:
Average Arrangement Time = $\Sigma(\text{Date Collocation Arrangement is Complete}) - (\text{Date Order for Collocation Arrangement Submitted}) / \text{Total Number of Collocation Arrangements Completed during Reporting Period}$.
Report Structure:
<ul style="list-style-type: none"> • Individual CLEC (alias) aggregate • Aggregate of all CLECs
Level of Disaggregation:
<ul style="list-style-type: none"> • State, Region and further geographic disaggregation as required by State Commission Order (e.g. Metropolitan Service Area – MSA) • Virtual • Physical
Data Retained:
<ul style="list-style-type: none"> • Report period • Aggregate data
Retail Analog/Benchmark:
See Appendix D

Revision Date: 01/27/00 (tg)

COLLOCATION

Report/Measurement:
C-3. Percent of Due Dates Missed
Definition:
Measures the percent of missed due dates for collocation arrangements.
Exclusions:
<ul style="list-style-type: none"> • Any Bona Fide firm order cancelled by the CLEC • Bona Fide firm orders to augment previously completed arrangements • Time for BST to obtain permits • Time during which the collocation contract is being negotiated
Business Rules:
The clock starts on the date that BST receives a complete and accurate Bona Fide firm order accompanied by the appropriate fee. The clock stops on the date that BST completes the collocation arrangement.
Calculation:
$\% \text{ of Due Dates Missed} = \frac{\Sigma (\text{Number of Orders not completed w/i ILEC Committed Due Date during Reporting Period})}{\text{Number of Orders Completed in Reporting Period}} \times 100$
Report Structure:
<ul style="list-style-type: none"> • Individual CLEC (alias) aggregate • Aggregate of all CLECs
Level of Disaggregation:
<ul style="list-style-type: none"> • State, Region and further geographic disaggregation as required by State Commission Order (e.g. Metropolitan Service Area-MSA) • Virtual • Physical
Data Retained:
<ul style="list-style-type: none"> • Report period • Aggregate data
Retail Analog/Benchmark:
90% ≤ Commit Date

Revision Date: 01/27/00 (tg)

Appendix A: Reporting Scope*

Standard Service Groupings	
Standard Service Groupings	<p><u>Pre-Order, Ordering</u></p> <ul style="list-style-type: none"> ➤ Resale Residence ➤ Resale Business ➤ Resale Special ➤ Local Interconnection Trunks ➤ UNE ➤ UNE - Loops w/LNP <p><u>Provisioning</u></p> <ul style="list-style-type: none"> ➤ UNE Non-Design ➤ UNE Design ➤ Local Interconnection Trunks ➤ Resale Residence ➤ Resale Business ➤ Resale Design ➤ BST Trunks ➤ BST Residence Retail ➤ BST Business Retail ➤ BST Design Retail <p><u>Maintenance and Repair</u></p> <ul style="list-style-type: none"> ➤ Local Interconnection Trunks ➤ UNE Non-Design ➤ UNE Design ➤ Resale Residence ➤ Resale Business ➤ Resale Design ➤ BST Interconnection Trunks ➤ BST Residence Retail ➤ BST Business Retail ➤ BST Design Retail <p><u>Local Interconnection Trunk Group Blockage</u></p> <ul style="list-style-type: none"> ➤ BST CTTG Trunk Groups ➤ CLEC Trunk Groups

Appendix A: Reporting Scope*

<p>Standard Service Order Activities</p> <p><i>These are the generic BST/CLEC service order activities which are included in the Pre-Ordering, Ordering, and Provisioning sections of this document. It is not meant to indicate specific reporting categories.</i></p>	<ul style="list-style-type: none"> ➤ New Service Installations ➤ Service Migrations Without Changes ➤ Service Migrations With Changes ➤ Move and Change Activities ➤ Service Disconnects (Unless noted otherwise)
<p>Pre-Ordering Query Types:</p> <p>Maintenance Query Types:</p>	<ul style="list-style-type: none"> ➤ Address ➤ Telephone Number ➤ Appointment Scheduling ➤ Customer Service Record ➤ Feature Availability
<p>Report Levels</p>	<ul style="list-style-type: none"> ➤ CLEC RESH ➤ CLEC MSA ➤ CLEC State ➤ CLEC Region ➤ Aggregate CLEC State ➤ Aggregate CLEC Region ➤ BST State ➤ BST Region

* Scope is report, data source and system dependent, and, therefore, will differ with each report.

Appendix B: Glossary of Acronyms and Terms

A	<p>ACD</p> <p>AGGREGATE</p> <p>ASR</p> <p>ATLAS</p> <p>ATLASTN</p> <p>AUTO CLARIFICATION</p>	<p>Automatic Call Distributor - A service that provides status monitoring of agents in a call center and routes high volume incoming telephone calls to available agents while collecting management information on both callers and attendants.</p> <p>Sum total of all items in like category, e.g. CLEC aggregate equals the sum total of all CLECs' data for a given reporting level.</p> <p>Access Service Request - A request for access service terminating delivery of carrier traffic into a Local Exchange Carrier's network.</p> <p>Application for Telephone Number Load Administration System - The BellSouth Operations System used to administer the pool of available telephone numbers and to reserve selected numbers from the pool for use on pending service requests/service orders.</p> <p>ATLAS software contract for Telephone Number</p> <p>The number of LSRs that were electronically rejected from LESOG and electronically returned to the CLEC for correction.</p>
B	<p>BILLING</p> <p>BOCRIS</p> <p>BRC</p> <p>BST</p>	<p>The process and functions by which billing data is collected and by which account information is processed in order to render accurate and timely billing.</p> <p>Business Office Customer Record Information System - A front-end presentation manager used by BellSouth organizations to access the CRIS database.</p> <p>Business Repair Center – The BellSouth Business Systems trouble receipt center which serves large business and CLEC customers.</p> <p>BellSouth Telecommunications, Inc.</p>
C	<p>CKTID</p> <p>CLEC</p> <p>CMDS</p> <p>COFFI</p>	<p>A unique identifier for elements combined in a service configuration</p> <p>Competitive Local Exchange Carrier</p> <p>Centralized Message Distribution System - BellCore administered national system used to transfer specially formatted messages among companies.</p> <p>Central Office Feature File Interface - A BellSouth Operations System database which maintains Universal Service Order Code (USOC) information based on current tariffs.</p>

Appendix B: Glossary of Acronyms and Terms – Continued

C	COFIUSOC	COFFI software contract for feature/service information
	CRIS	Customer Record Information System - The BellSouth proprietary corporate database and billing system for non-access customers and services.
	CRSACCTS	CRIS software contract for CSR information
	CSR	Customer Service Record
	CTTG	Common Transport Trunk Group - Final trunk groups between BST & Independent end offices and the BST access tandems.
D	DESIGN	Design Service is defined as any Special or Plain Old Telephone Service Order which requires BellSouth Design Engineering Activities
	DISPOSITION & CAUSE	Types of trouble conditions, e.g. No Trouble Found, Central Office Equipment, Customer Premises Equipment, etc.
	DLETH	Display Lengthy Trouble History - A history report that gives all activity on a line record for trouble reports in LMOS
	DLR	Detail Line Record - All the basic information maintained on a line record in LMOS, e.g. name, address, facilities, features etc.
	DOE	Direct Order Entry System - An internal BellSouth service order entry system used by BellSouth Service Representatives to input business service orders in BellSouth format.
	DSAP	DOE (Direct Order Entry) Support Application - The BellSouth Operations System which assists a Service Representative or similar carrier agent in negotiating service provisioning commitments for non-designed services and UNEs.
	DSAPDDI	DSAP software contract for schedule information
E	E911	Provides callers access to the applicable emergency services bureau by dialing a 3-digit universal telephone number.
	EDI	Electronic Data Interchange - The computer-to-computer exchange of inter and/or intra company business documents in a public standard format.
F	FATAL REJECT	The number of LSRs that were electronically rejected from LEO, which checks to see if the LSR has all the required fields correctly populated
	FLOW-THROUGH	In the context of this document, LSRs submitted electronically via the CLEC mechanized ordering process that flow through to the BST OSS without manual or human intervention.
	FOC	Firm Order Confirmation - A notification returned to the CLEC confirming that the LSR has been received and accepted, including the specified commitment date.

Appendix B: Glossary of Acronyms and Terms - Continued

G		
H	HAL	“Hands Off” Assignment Logic - Front end access and error resolution logic used in interfacing BellSouth Operations Systems such as ATLAS, BOCRIS, LMOS, PSIMS, RSAG and SOCS.
	HALCRIS	HAL software contract for CSR information
I	ISDN	Integrated Services Digital Network
K		
L	LCSC	Local Carrier Service Center - The BellSouth center which is dedicated to handling CLEC LSRs, ASRs, and Preordering transactions along with associated expedite requests and escalations.
	LEGACY SYSTEM	Term used to refer to BellSouth Operations Support Systems (see OSS)
	LENS	Local Exchange Negotiation System - The BellSouth LAN/web server/OS application developed to provide both preordering and ordering electronic interface functions for CLECs.
	LEO	Local Exchange Ordering - A BellSouth system which accepts the output of EDI, applies edit and formatting checks, and reformats the Local Service Requests in BellSouth Service Order format.
	LESOG	Local Exchange Service Order Generator - A BellSouth system which accepts the service order output of LEO and enters the Service Order into the Service Order Control System using terminal emulation technology.
	LMOS	Loop Maintenance Operations System - A BellSouth Operations System that stores the assignment and selected account information for use by downstream OSS and BellSouth personnel during provisioning and maintenance activities.
	LMOS HOST	LMOS host computer
	LMOSupd	LMOS updates
	LNP	Local Number Portability - In the context of this document, the capability for a subscriber to retain his current telephone number as he transfers to a different local service provider.
	LOOPS	Transmission paths from the central office to the customer premises.
M	MAINTENANCE & REPAIR	The process and function by which trouble reports are passed to BellSouth and by which the related service problems are resolved.
	MARCH	A BellSouth Operations System which accepts service orders, interprets the coding contained in the service order image, and constructs the specific switching system Recent Change command messages for input into end office switches.

Appendix B: Glossary of Acronyms and Terms – Continued

N	NC	“No Circuits” - All circuits busy announcement
O	OASIS	Obtain Availability Services Information System - A BellSouth front-end processor, which acts as an interface between COFFI and RNS. This system takes the USOCs in COFFI and translates them to English for display in RNS.
	OASISBSN	OASIS software contract for feature/service
	OASISCAR	OASIS software contract for feature/service
	OASISLPC	OASIS software contract for feature/service
	OASISMTN	OASIS software contract for feature/service
	OASISNET	OASIS software contract for feature/service
	OASISOCP	OASIS software contract for feature/service
	ORDERING	The process and functions by which resale services or unbundled network elements are ordered from BellSouth as well as the process by which an LSR or ASR is placed with BellSouth.
	OSPCM	Outside Plant Contract Management System - Provides Scheduling Information.
	OSS	Operations Support System - A support system or database which is used to mechanize the flow or performance of work. The term is used to refer to the overall system consisting of hardware complex, computer operating system(s), and application which is used to provide the support functions.
	OUT OF SERVICE	Customer has no dial tone and cannot call out.
P	POTS	Plain Old Telephone Service
	PREDICTOR	The BellSouth Operations system which is used to administer proactive maintenance and rehabilitation activities on outside plant facilities, provide access to selected work groups (e.g. RRC & BRC) to Mechanized Loop Testing and switching system I/O ports, and provide certain information regarding the attributes and capabilities of outside plant facilities.
	PREORDERING	The process and functions by which vital information is obtained, verified, or validated prior to placing a service request.
	PROVISIONING	The process and functions by which necessary work is performed to activate a service requested via an LSR or ASR and to initiate the proper billing and accounting functions.
	PSIMS	Product/Service Inventory Management System - A BellSouth database Operations System which contains availability information on switching system features and capabilities and on BellSouth service availability. This database is used to verify the availability of a feature or service in an NXX prior to making a commitment to the customer.
	PSIMSORB	PSIMS software contract for feature/service

Appendix B: Glossary of Acronyms and Terms – Continued

Q		
R	RNS	Regional Negotiation System - An internal BellSouth service order entry system used by BellSouth Consumer Services to input service orders in BellSouth format.
	RRC	Residence Repair Center - The BellSouth Consumer Services trouble receipt center which serves residential customers.
	RSAG	Regional Street Address Guide - The BellSouth database, which contains street addresses validated to be accurate with state and local governments. RSAG software contract for address search
	RSAGADDR	RSAG software contract for telephone number search
	RSAGTN	
S	SOCS	Service Order Control System - The BellSouth Operations System which routes service order images among BellSouth drop points and BellSouth Operations Systems during the service provisioning process.
	SOIR	Service Order Interface Record - any change effecting activity to a customer account by service order that impacts 911/E911.
T	TAFI	Trouble Analysis Facilitation Interface - The BellSouth Operations System that supports trouble receipt center personnel in taking and handling customer trouble reports.
	TAG	Telecommunications Access Gateway – TAG was designed to provide an electronic interface, or machine-to-machine interface for the bi-directional flow of information between BellSouth’s OSSs and participating CLECs.
	TN	Telephone Number
	TOTAL MANUAL FALLOUT	The number of LSRs which are entered electronically but require manual entering into a service order generator.
U	UNE	Unbundled Network Element
V		
W	WTN	A unique identifier for elements combined in a service configuration
X		
Y		
Z		
Σ		Sum of:

Appendix C

BELLSOUTH'S AUDIT POLICY:

BellSouth currently provides many CLECs with certain audit rights as a part of their individual interconnection agreements. However, it is not reasonable for BellSouth to undergo an audit of the SQM for every CLEC with which it has a contract. BellSouth has developed a proposed Audit Plan for use by the parties to an audit. If requested by a Public Service Commission or by a CLEC exercising contractual audit rights, BellSouth will agree to undergo a comprehensive audit of the aggregate level reports for both BellSouth and the CLEC(s) for each of the next five (5) years (2000 – 2005), to be conducted by an independent third party. The results of that audit will be made available to all the parties subject to proper safeguards to protect proprietary information. This aggregate level audit includes the following specifications:

1. The cost shall be borne 50% by BellSouth and 50% by the CLEC or CLECs.
2. The independent third party auditor shall be selected with input from BellSouth, the PSC, if applicable, and the CLEC(s).
3. BellSouth, the PSC and the CLEC(s) shall jointly determine the scope of the audit.

BellSouth reserves the right to make changes to this audit policy as growth and changes in the industry dictate.

APPENDIX D				
Analogs and Benchmarks				
BST SQM Category	MEASURES AND SUB-METRICS	RESALE Retail Analogue	UNES Retail Analogue	Benchmark*
Pre-Ordering	<u>Percent Response Received within "X" seconds</u>		Parity w/ retail where applicable.	
	<u>OSS Interface Availability</u>			99.5%
Ordering	<u>Percent Flow-Through Service Request</u> <ul style="list-style-type: none"> • Residence • Business • UNE 			90% 80% 80%
	<u>Percent Rejected Service Request</u>	Diagnostic		Diagnostic.
	Reject Interval (Mechanized)	UD	UD	95% within 1 hrs
	• Reject Interval (Non-Mechanized and Partially Mechanized)	UD	UD	85% < 24 hrs
	Firm Order Confirmation Timeliness (Mechanized) (Non-Mechanized and Partially Mechanized)	UD	UD	95% within 4 hrs 85% <48 Hrs
	<u>Speed of Answer in Ordering Center</u>	X	X	
Provisioning	<u>Mean Held Order Interval</u>			
	• Resale Residence	X		
	• Resale Business	X		
	• Resale Design	X		
	• Resale PBX	X		
	• Resale Centrex	X		
	• Resale IDSN	X		
	• UNE Loop and Port Combos		Retail Residence and Business	
	• UNE 2w Loop with NP – Non-Design		Retail Residence and Business	
	• UNE 2w Loop without NP – Non-Design		Retail Residence and Business	
	• UNE Loop Other with NP Non-Design		Retail Residence and Business	
	• UNE Loop Other without NP Non-Design		Retail Residence and Business	
	• UNE Other Non Design		Retail Residence and Business	
	• UNE 2w Loop with NP – Design		Retail Residence and Business	
	• UNE 2w Loop without NP – Design		Retail Residence and Business	
	• UNE Loop Other with NP – Design		Retail Design	

APPENDIX D Analog and Benchmarks				
BST SQM Category	MEASURES AND SUB-METRICS	RESALE Retail Analogue	UNES Retail Analogue	Benchmark*
	• UNE Loop Other without NP - Design		Retail Design	
	• UNE Other Design		Retail Design	
	• Local Interconnection Trunks	X		
	Average Jeopardy Notice Interval (Mechanized)			
	• Resale Residence			95% >=24 Hrs.
	• Resale Business			95% >=24 Hrs.
	• Resale Design			95% >=24 Hrs.
	• Resale PBX			95% >=24 Hrs.
	• Resale Centrex			95% >=24 Hrs.
	• Resale IDSN			95% >=24 Hrs.
	• UNE Loop and Port Combos			95% >=24 Hrs.
	• UNE 2w Loop with NP – Non-Design			95% >=24 Hrs.
	• UNE 2w Loop without NP – Non-Design			95% >=24 Hrs.
	• UNE Loop Other with NP Non-Design			95% >=24 Hrs.
	• UNE Loop Other without NP Non-Design			95% >=24 Hrs.
	• UNE Other Non Design			95% >=24 Hrs.
	• UNE 2w Loop with NP – Design			95% >=24 Hrs.
	• UNE 2w Loop without NP – Design			95% >=24 Hrs.
	• UNE Loop Other with NP – Design			95% >=24 Hrs.
	• UNE Loop Other without NP - Design			95% >=24 Hrs.
	• UNE Other Design			95% >=24 Hrs.
	• Local Interconnection Trunks			95% >=24 Hrs.
	% of Orders given jeopardy notice (Mechanized)			
	• Resale Residence	X		
	• Resale Business	X		
	• Resale Design	X		
	• Resale PBX	X		
	• Resale Centrex	X		
	• Resale IDSN	X		
	• UNE Loop and Port Combos		Retail Residence and Business	
	• UNE 2w Loop with NP – Non-Design		Retail Residence and Business	
	• UNE 2w Loop without NP – Non-Design		Retail Residence and Business	
	• UNE Loop Other with NP Non-Design		Retail Residence and Business	

APPENDIX D				
Analogs and Benchmarks				
BST SQM Category	MEASURES AND SUB-METRICS	RESALE Retail Analogue	UNES Retail Analogue	Benchmark*
	• UNE Loop Other without NP Non-Design		Retail Residence and Business	
	• UNE Other Non Design		Retail Residence and Business	
	• UNE 2w Loop with NP – Design		Retail Residence and Business	
	• UNE 2w Loop without NP – Design		Retail Residence and Business	
	• UNE Loop Other with NP – Design		Retail Design	
	• UNE Loop Other without NP - Design		Retail Design	
	• UNE Other Design		Retail Design	
	• Local Interconnection Trunks	X		
	<u>Percent Missed Installation Appointments</u>			
	• Resale Residence	X		
	• Resale Business	X		
	• Resale Design	X		
	• Resale PBX	X		
	• Resale Centrex	X		
	• Resale IDSN	X		
	• UNE Loop and Port Combos		Retail Residence and Business	
	• UNE 2w Loop with NP – Non-Design		Retail Residence and Business	
	• UNE 2w Loop without NP – Non-Design		Retail Residence and Business	
	• UNE Loop Other with NP Non-Design		Retail Residence and Business	
	• UNE Loop Other without NP Non-Design		Retail Residence and Business	
	• UNE Other Non Design		Retail Residence and Business	
	• UNE 2w Loop with NP – Design		Retail Residence and Business	
	• UNE 2w Loop without NP – Design		Retail Residence and Business	
	• UNE Loop Other with NP – Design		Retail Design	
	• UNE Loop Other without NP – Design		Retail Design	
	• UNE Other Design		Retail Design	
	• Local Interconnection Trunks	X		
	<u>Order Completion Interval</u>			
	• Resale Residence	X		
	• Resale Business	X		
	• Resale Design	X		
	• Resale PBX	X		
	• Resale Centrex	X		

APPENDIX D				
Analogs and Benchmarks				
BST SQM Category	MEASURES AND SUB-METRICS	RESALE Retail Analogue	UNES Retail Analogue	Benchmark*
	• Resale IDSN	X		
	• UNE Loop and Port Combos		Retail Residence and Business	
	• UNE 2w Loop with NP – Non-Design		Retail Residence and Business	
	• UNE 2w Loop without NP – Non-Design		Retail Residence and Business	
	• UNE Loop Other with NP Non-Design		Retail Residence and Business	
	• UNE Loop Other without NP Non-Design		Retail Residence and Business	
	• UNE Other Non Design		Retail Residence and Business	
	• UNE 2w Loop with NP – Design		Retail Residence and Business	
	• UNE 2w Loop without NP – Design		Retail Residence and Business	
	• UNE Loop Other with NP – Design		Retail Design	
	• UNE Loop Other without NP - Design		Retail Design	
	• UNE Other Design		Retail Design	
	• Local Interconnection Trunks	X		
	<u>Average Completion Notice Interval – Resale POTS (Mech)</u>			
	• Resale Residence	X		
	• Resale Business	X		
	• Resale Design	X		
	• Resale PBX	X		
	• Resale Centrex	X		
	• Resale IDSN	X		
	• UNE Loop and Port Combos		Retail Residence and Business	
	• UNE 2w Loop with NP – Non-Design		Retail Residence and Business	
	• UNE 2w Loop without NP – Non-Design		Retail Residence and Business	
	• UNE Loop Other with NP Non-Design		Retail Residence and Business	
	• UNE Loop Other without NP Non-Design		Retail Residence and Business	
	• UNE Other Non Design		Retail Residence and Business	
	• UNE 2w Loop with NP – Design		Retail Residence and Business	
	• UNE 2w Loop without NP – Design		Retail Residence and Business	
	• UNE Loop Other with NP – Design		Retail Design	
	• UNE Loop Other without NP - Design		Retail Design	
	• UNE Other Design		Retail Design	
	• Local Interconnection Trunks	X		
	<u>Percent Provisioning Troubles within 30 Days</u>			

APPENDIX D Analog and Benchmarks				
BST SQM Category	MEASURES AND SUB-METRICS	RESALE Retail Analogue	UNES Retail Analogue	Benchmark*
	• Resale Residence	X		
	• Resale Business	X		
	• Resale Design	X		
	• Resale PBX	X		
	• Resale Centrex	X		
	• Resale IDSN	X		
	• UNE Loop and Port Combos		Retail Residence and Business	
	• UNE 2w Loop with NP – Non-Design		Retail Residence and Business	
	• UNE 2w Loop without NP – Non-Design		Retail Residence and Business	
	• UNE Loop Other with NP Non-Design		Retail Residence and Business	
	• UNE Loop Other without NP Non-Design		Retail Residence and Business	
	• UNE Other Non Design		Retail Residence and Business	
	• UNE 2w Loop with NP – Design		Retail Residence and Business	
	• UNE 2w Loop without NP – Design		Retail Residence and Business	
	• UNE Loop Other with NP – Design		Retail Design	
	• UNE Loop Other without NP - Design		Retail Design	
	• UNE Other Design		Retail Design	
	• Local Interconnection Trunks	X		
	<u>Total Service Order Cycle Time</u>	Diag.	Diagnostic	Diagnostic
Maintenance	<u>Customer Trouble Report Rate</u>			
	• Resale Residence	X		
	• Resale Business	X		
	• Resale Design	X		
	• Resale PBX	X		
	• Resale Centrex	X		
	• Resale IDSN	X		
	• UNE Loop and Port Combos		Retail Residence and Business	
	• UNE 2w Loop – Non-Design		Retail Residence and Business	
	• UNE Loop Other - Non-Design		Retail Residence and Business	
	• UNE Other Non Design		Retail Residence and Business	
	• UNE 2w Loop – Design		Retail Residence and Business	
	• UNE Loop Other – Design		Retail Design	
	• UNE Other Design		Retail Design	

APPENDIX D Analog and Benchmarks				
BST SQM Category	MEASURES AND SUB-METRICS	RESALE Retail Analogue	UNES Retail Analogue	Benchmark*
	• Local Interconnection Trunks	X		
	<u>Percent Missed Repair Appointments</u>			
	• Resale Residence	X		
	• Resale Business	X		
	• Resale Design	X		
	• Resale PBX	X		
	• Resale Centrex	X		
	• Resale IDSN	X		
	• UNE Loop and Port Combos		Retail Residence and Business	
	• UNE 2w Loop – Non-Design		Retail Residence and Business	
	• UNE Loop Other - Non-Design		Retail Residence and Business	
	• UNE Other Non Design		Retail Residence and Business	
	• UNE 2w Loop – Design		Retail Residence and Business	
	• UNE Loop Other – Design		Retail Design	
	• UNE Other Design		Retail Design	
	• Local Interconnection Trunks	X		
	<u>Maintenance Average Duration</u>			
	• Resale Residence	X		
	• Resale Business	X		
	• Resale Design	X		
	• Resale PBX	X		
	• Resale Centrex	X		
	• Resale IDSN	X		
	• UNE Loop and Port Combos		Retail Residence and Business	
	• UNE 2w Loop – Non-Design		Retail Residence and Business	
	• UNE Loop Other - Non-Design		Retail Residence and Business	
	• UNE Other Non Design		Retail Residence and Business	
	• UNE 2w Loop – Design		Retail Residence and Business	
	• UNE Loop Other – Design		Retail Design	
	• UNE Other Design		Retail Design	
	• Local Interconnection Trunks	X		
	<u>Percent Repeat Troubles within 30 Days</u>			
	• Resale Residence	X		

APPENDIX D				
Analogs and Benchmarks				
BST SQM Category	MEASURES AND SUB-METRICS	RESALE Retail Analogue	UNES Retail Analogue	Benchmark*
	• Resale Business	X		
	• Resale Design	X		
	• Resale PBX	X		
	• Resale Centrex	X		
	• Resale IDSN	X		
	• UNE Loop and Port Combos		Retail Residence and Business	
	• UNE 2w Loop – Non-Design		Retail Residence and Business	
	• UNE Loop Other - Non-Design		Retail Residence and Business	
	• UNE Other Non Design		Retail Residence and Business	
	• UNE 2w Loop – Design		Retail Residence and Business	
	• UNE Loop Other – Design		Retail Design	
	• UNE Other Design		Retail Design	
	• Local Interconnection Trunks	X		
	<u>Out of Service > 24hrs</u>			
	• Resale Residence	X		
	• Resale Business	X		
	• Resale Design	X		
	• Resale PBX	X		
	• Resale Centrex	X		
	• Resale IDSN	X		
	• UNE Loop and Port Combos		Retail Residence and Business	
	• UNE 2w Loop – Non-Design		Retail Residence and Business	
	• UNE Loop Other - Non-Design		Retail Residence and Business	
	• UNE Other Non Design		Retail Residence and Business	
	• UNE 2w Loop – Design		Retail Residence and Business	
	• UNE Loop Other – Design		Retail Design	
	• UNE Other Design		Retail Design	
	• Local Interconnection Trunks	X		
	<u>OSS Interface Availability</u>			
	• All systems except ECTA	X		
	• <u>ECTA</u>			99.5%
	<u>OSS Response Interval and %</u>			
	• TAFI (Front End)	X		

APPENDIX D Analog and Benchmarks				
BST SQM Category	MEASURES AND SUB-METRICS	RESALE Retail Analogue	UNES Retail Analogue	Benchmark*
	<ul style="list-style-type: none"> CRIS, DLETH, DLR, OSPCM, LMOS, LMOSUP, MARCH, Predictor, SOCS, LNP (Parity by Design) 	PBD		
	<u>Average Answer Time – Repair Center</u>	X		
Billing	<u>Invoice Accuracy</u>	X		
	Mean Time To Deliver Invoices	X		
	Usage Data Delivery Accuracy	X		
	Usage Data Delivery Timeliness	X		
	Usage Data Delivery Completeness	X		
	Mean Time to Deliver Usage	X		
Operator Services (Toll)	Average Speed to Answer	PBD		
	% Answered in “X” Seconds	PBD		
Directory Assistance	Average Speed to Answer	PBD		
	% Answered in “X” Seconds	PBD		
E911	Timeliness	PBD		
	<u>Accuracy</u>	PBD		
	Mean Interval	PBD		
Trunk Group Performance (Blockage)	Trunk Group Service Report (Percent Trunk Blockage) Any 2 hour period in 24 hours where CLEC blockage exceeds BST blockage by more than 0.5% = a miss using trunk groups 1, 3, 4, 5, 10, 16 for CLECs and 9 for BST.	X		
	Trunk Group Service Report (Percent Trunk Blockage)	X		
LNP	<u>Average Disconnect Timeliness Interval</u>			
	Percent Missed Installation Appointments		Retail Residence and Business	
	FOC Mechanized			95% ≤4 hours
	% Reject Service Request		Diagnostic	
	Average Reject Interval Mechanized			95% ≤1 hour
	TSOC		Diagnostic	
	% Flow Through			80%

APPENDIX D Analog and Benchmarks				
BST SQM Category	MEASURES AND SUB-METRICS	RESALE Retail Analogue	UNES Retail Analogue	Benchmark*
Customer Coordinated Conversions	<u>Coordinated Customer Conversions – UNE Loop</u>			95% ≤ 15min
	<u>Coordinated Customer Conversions – LNP</u>			95% ≤ 15 min
Collocation +	% of Due Dates Missed			90% ≤ Commit Date
	Average Response Time		FL PSC is addressing this in generic docket	
+A contract with each CLEC required.	<u>Average Arrangement Time</u>		FL PSC is addressing this in generic docket	

Note 1: PBD = Parity by Design. UD = Under Development – Benchmarks will be replaced when Analogs are complete.

Note2: The retail analog for UNE Non-Design and UNE 2w Loops – Design is the average of Retail Residence Dispatch and Retail Business Dispatch transactions for the particular month. The retail analog for other UNE Design is Retail Design Dispatch.

Note3: Analogs and Benchmarks will be re-evaluated periodically, at least once a year, to validate applicability.

EXHIBIT B

VSEEMIII TIER-1 SUBMETRICS

- ❑ FOC Timeliness (Mechanized only)
- ❑ Reject Interval (Mechanized only)
- ❑ Order Completion Interval (Dispatch only) – Resale POTS
- ❑ Order Completion Interval (Dispatch only) – Resale Design
- ❑ Order Completion Interval (No Dispatch only) – UNE Loop and Port Combos
- ❑ Order Completion Interval ('w' code orders, Dispatch only) – UNE Loops
- ❑ Order Completion Interval (Dispatch only) – IC Trunks
- ❑ Percent Missed Installation Appointments – Resale POTS
- ❑ Percent Missed Installation Appointments – Resale Design
- ❑ Percent Missed Installation Appointments – UNE Loop and Port Combos
- ❑ Percent Missed Installation Appointments – UNE Loops
- ❑ Percent Provisioning Troubles within 4 Days - Resale POTS
- ❑ Percent Provisioning Troubles within 4 Days - Resale Design
- ❑ Percent Provisioning Troubles within 4 Days - UNE Loop and Port Combos
- ❑ Percent Provisioning Troubles within 4 Days - UNE Loops
- ❑ Customer Trouble Report Rate – Resale POTS
- ❑ Customer Trouble Report Rate – Resale Design
- ❑ Customer Trouble Report Rate - UNE Loop and Port Combos
- ❑ Customer Trouble Report Rate - UNE Loops
- ❑ Percent Missed Repair Appointments – Resale POTS
- ❑ Percent Missed Repair Appointments - Resale Design
- ❑ Percent Missed Repair Appointments - UNE Loop and Port Combos
- ❑ Percent Missed Repair Appointments - UNE Loops
- ❑ Maintenance Average Duration – Resale POTS
- ❑ Maintenance Average Duration – Resale Design
- ❑ Maintenance Average Duration - UNE Loop and Port Combos
- ❑ Maintenance Average Duration - UNE Loops
- ❑ Maintenance Average Duration – IC Trunks
- ❑ Percent Repeat Troubles within 30 Days – Resale POTS
- ❑ Percent Repeat Troubles within 30 Days – Resale Design
- ❑ Percent Repeat Troubles within 30 Days - UNE Loop and Port Combos
- ❑ Percent Repeat Troubles within 30 Days - UNE Loops
- ❑ Percent Trunk Blockage
- ❑ LNP Disconnect Timeliness
- ❑ LNP Percent Missed Installation Appointment
- ❑ Coordinated Customer Conversions for UNE Loops
- ❑ Coordinated Customer Conversions for LNP
- ❑ Percent Missed Collocation Due Dates

VSEEMIII TIER-2 SUBMETRICS

- ❑ Percent Response Received within “X” seconds – Pre-Order OSS
- ❑ OSS Interface Availability
- ❑ Order Process Percent Flow-Through (Mechanized only)
- ❑ Order Completion Interval (Dispatch only) – Resale POTS
- ❑ Order Completion Interval (Dispatch only) – Resale Design
- ❑ Order Completion Interval (No Dispatch only) – UNE Loop and Port Combos
- ❑ Order Completion Interval (‘w’ code orders, Dispatch only) – UNE Loops
- ❑ Order Completion Interval (Dispatch only) – IC Trunks
- ❑ Percent Missed Installation Appointments – Resale POTS
- ❑ Percent Missed Installation Appointments – Resale Design
- ❑ Percent Missed Installation Appointments – UNE Loop and Port Combos
- ❑ Percent Missed Installation Appointments – UNE Loops
- ❑ Percent Provisioning Troubles within 4 Days - Resale POTS
- ❑ Percent Provisioning Troubles within 4 Days - Resale Design
- ❑ Percent Provisioning Troubles within 4 Days - UNE Loop and Port Combos
- ❑ Percent Provisioning Troubles within 4 Days - UNE Loops
- ❑ Customer Trouble Report Rate – Resale POTS
- ❑ Customer Trouble Report Rate – Resale Design
- ❑ Customer Trouble Report Rate - UNE Loop and Port Combos
- ❑ Customer Trouble Report Rate - UNE Loops
- ❑ Percent Missed Repair Appointments – Resale POTS
- ❑ Percent Missed Repair Appointments - Resale Design
- ❑ Percent Missed Repair Appointments - UNE Loop and Port Combos
- ❑ Percent Missed Repair Appointments - UNE Loops
- ❑ Maintenance Average Duration – Resale POTS
- ❑ Maintenance Average Duration – Resale Design
- ❑ Maintenance Average Duration - UNE Loop and Port Combos
- ❑ Maintenance Average Duration - UNE Loops
- ❑ Maintenance Average Duration – IC Trunks
- ❑ Percent Repeat Troubles within 30 Days – Resale POTS
- ❑ Percent Repeat Troubles within 30 Days – Resale Design
- ❑ Percent Repeat Troubles within 30 Days - UNE Loop and Port Combos
- ❑ Percent Repeat Troubles within 30 Days - UNE Loops
- ❑ Billing Timeliness
- ❑ Billing Accuracy
- ❑ Usage Data Delivery Timeliness
- ❑ Usage Data Delivery Accuracy
- ❑ Percent Trunk Blockage
- ❑ LNP Disconnect Timeliness
- ❑ LNP Percent Missed Installation Appointment
- ❑ Coordinated Customer Conversions for UNE Loops
- ❑ Coordinated Customer Conversions for LNP
- ❑ Percent Missed Collocation Due Dates

VSEEMIII TIER-3 SUBMETRICS

- ❑ Percent Missed Installation Appointments – Resale POTS
- ❑ Percent Missed Installation Appointments – Resale Design
- ❑ Percent Missed Installation Appointments – UNE Loop and Port Combos
- ❑ Percent Missed Installation Appointments – UNE Loops
- ❑ Percent Missed Repair Appointments – Resale POTS
- ❑ Percent Missed Repair Appointments - Resale Design
- ❑ Percent Missed Repair Appointments - UNE Loop and Port Combos
- ❑ Percent Missed Repair Appointments - UNE Loops
- ❑ Billing Timeliness
- ❑ Billing Accuracy
- ❑ Percent Trunk Blockage
- ❑ Percent Missed Collocation Due Dates

VSEEM III	MEASURES AND SUB-METRICS	RETAIL ANALOGUE Resale (x) and UNEs	BENCH MARK
Pre-Ordering	Percent Response Received within "X" seconds	Retail Analogue + 4 sec	
	OSS Interface Availability	x	
Ordering	Percent Flow-Through Service Request (Fully Mechanized only)		90%
	Firm Order Confirmation Timeliness (Mechanized only)		95% ≤ 4 hrs
	Reject Interval (Mechanized only)		95% ≤ 1 hrs
Provisioning	Order Completion Interval (Dispatch only) – Resale POTS	x	
	Order Completion Interval (Dispatch only) – Resale Design	x	
	Order Completion Interval (No Dispatch only) – UNE Loop & Port Combos	Retail Residence and Business	
	Order Completion Interval (Dispatch only) – UNE Loops	Design: Retail Design Dispatch 'w' Orders Non-Design: Retail Res, Bus Dispatch 'w' Orders	
	Order Completion Interval (Dispatch only) – IC Trunks	x	
	Percent Missed Installation Appointments – Resale POTS	x	
	Percent Missed Installation Appointments – Resale Design	x	
	Percent Missed Installation Appointments – UNE Loop and Port Combos	Retail Residence and Business	
	Percent Missed Installation Appointments – UNE Loops	Design: Retail Design ¹ Non-Design: Retail Res, Bus ¹	
	Percent Provisioning Troubles within 4 Days - Resale POTS	x	
	Percent Provisioning Troubles within 4 Days - Resale Design	x	
	Percent Provisioning Troubles within 4 Days - UNE Loop and Port Combos	Retail Residence and Business	
	Percent Provisioning Troubles within 4 Days - UNE Loops	Design: Retail Design ¹ Non-Design: Retail Res, Bus ¹	
Maintenance	Customer Trouble Report Rate – Resale POTS	x	
	Customer Trouble Report Rate – Resale Design	x	
	Customer Trouble Report Rate - UNE Loop and Port Combos	Retail Residence and Business	
	Customer Trouble Report Rate - UNE Loops	Design: Retail Design ¹ Non-Design: Retail Res, Bus ¹	
	Percent Missed Repair Appointments – Resale POTS	x	
	Percent Missed Repair Appointments - Resale Design	x	
	Percent Missed Repair Appointments - UNE Loop and Port Combos	Retail Residence and Business	
	Percent Missed Repair Appointments - UNE Loops	Design: Retail Design ¹ Non-Design: Retail Res, Bus ¹	

NOTES: ¹ The retail analog for UNE Non-Design is the average of all retail residence and retail business transactions for the particular month.
 The retail analog for UNE Design is calculated similarly using retail residence, business and design results.
² UD = Under Development

Maintenance Continued	Maintenance Average Duration – Resale POTS	x	
	Maintenance Average Duration – Resale Design	x	
	Maintenance Average Duration - UNE Loop and Port Combos	Retail Residence and Business	
	Maintenance Average Duration - UNE Loops	Design: Retail Design ¹ Non-Design: Retail Res, Bus ¹	
	Maintenance Average Duration – IC Trunks	x	
	Percent Repeat Troubles within 30 Days – Resale POTS	x	
	Percent Repeat Troubles within 30 Days – Resale Design	x	
	Percent Repeat Troubles within 30 Days - UNE Loop and Port Combos	Retail Residence and Business	
	Percent Repeat Troubles within 30 Days - UNE Loops	Design: Retail Design ¹ Non-Design: Retail Res, Bus ¹	
Billing	Invoice Accuracy	x	
	Mean Time To Deliver Invoices	x	
	Usage Data Delivery Accuracy	x	
	Usage Data Delivery Timeliness	x	
Trunk Blockage	Trunk Group Service Report (Percent Trunk Blockage)	x	
LNP	Average Disconnect Timeliness Interval		UD ²
	Percent Missed Installation Appointments		UD ²
CC	Coordinated Customer Conversions – UNE Loop		95% ≤ 15min
Conversions	Coordinated Customer Conversions – LNP		95% ≤ 15 min
Collocation	% of Due Dates Missed		≤ 10%

NOTES: ¹ The retail analog for UNE Non-Design is the average of all retail residence and retail business transactions for the particular month.
 The retail analog for UNE Design is calculated similarly using retail residence, business and design results.
² UD = Under Development

EXHIBIT C

Statistical Methods for BellSouth Performance Measure Analysis

I. Necessary Properties for a Test Methodology

The statistical process for testing if competing local exchange carriers (CLECs) customers are being treated equally with BellSouth (BST) customers involves more than just a mathematical formula. Three key elements need to be considered before an appropriate decision process can be developed. These are

- the type of data,
- the type of comparison, and
- the type of performance measure.

Once these elements are determined a test methodology should be developed that complies with the following properties.

- Like-to-Like Comparisons. When possible, data should be compared at appropriate levels, e.g. wire center, time of month, dispatched, residential, new orders. The testing process should:
 - Identify variables that may affect the performance measure.
 - Record these important confounding covariates.
 - Adjust for the observed covariates in order to remove potential biases and to make the CLEC and the ILEC units as comparable as possible.
- Aggregate Level Test Statistic. Each performance measure of interest should be summarized by one overall test statistic giving the decision maker a rule that determines whether a statistically significant difference exists. The test statistic should have the following properties.
 - The method should provide a single overall index, on a standard scale.
 - If entries in comparison cells are exactly proportional over a covariate, the aggregated index should be very nearly the same as if comparisons on the covariate had not been done.
 - The contribution of each comparison cell should depend on the number of observations in the cell.
 - Cancellation between comparison cells should be limited.
 - The index should be a continuous function of the observations.
- Production Mode Process. The decision system must be developed so that it does not require intermediate manual intervention, i.e. the process must be a “black box.”
 - Calculations are well defined for possible eventualities.
 - The decision process is an algorithm that needs no manual intervention.
 - Results should be arrived at in a timely manner.
 - The system must recognize that resources are needed for other performance measure-related processes that also must be run in a timely manner.
 - The system should be auditable, and adjustable over time.
- Balancing. The testing methodology should balance Type I and Type II Error probabilities.
 - $P(\text{Type I Error}) = P(\text{Type II Error})$ for well defined null and alternative hypotheses.
 - The formula for a test’s balancing critical value should be simple enough to calculate using standard mathematical functions, i.e. one should avoid methods that require computationally intensive techniques.

- Little to no information beyond the null hypothesis, the alternative hypothesis, and the number of observations should be required for calculating the balancing critical value.

In the following sections we describe appropriate testing processes that adhere as much as possible to the testing principles.

Measurement Types

The performance measures that will undergo testing are of three types:

- 1) means
- 2) proportions, and
- 3) rates

While all three have similar characteristics (a proportion is the average of a measure that takes on only the values of 0 or 1), a proportion or rate is derived from count data while a mean is generally an average of interval measurements.

II. Testing Methodology – The Truncated Z

Many covariates are chosen in order to provide deep comparison levels. In each comparison cell, a Z statistic is calculated. The form of the Z statistic may vary depending on the performance measure, but it should be distributed approximately as a standard normal, with mean zero and variance equal to one. Assuming that the test statistic is derived so that it is negative when the performance for the CLEC is worse than for the ILEC, a positive truncation is done – i.e. if the result is negative it is left alone, if the result is positive it is changed to zero. A weighted average of the truncated statistics is calculated where a cell weight depends on the volume of BST and CLEC orders in the cell. The weighted average is re-centered by the theoretical mean of a truncated distribution, and this is divided by the standard error of the weighted average. The standard error is computed assuming a fixed effects model.

Proportion Measures

For performance measures that are calculated as a proportion, in each adjustment cell, the truncated Z and the moments for the truncated Z can be calculated in a direct manner. In adjustment cells where proportions are not close to zero or one, and where the sample sizes are reasonably large, a normal approximation can be used. In this case, the moments for the truncated Z come directly from properties of the standard normal distribution. If the normal approximation is not appropriate, then the Z statistic is calculated from the hypergeometric distribution. In this case, the moments of the truncated Z are calculated exactly using the hypergeometric probabilities.

Rate Measures

The truncated Z methodology for rate measures has the same general structure for calculating the Z in each cell as proportion measures. For a rate measure, there are a fixed number of circuits or units for the CLEC, n_{2j} and a fixed number of units for BST, n_{1j} . Suppose that the performance measure is a “trouble rate.” The modeling assumption is that the occurrence of a trouble is independent between units and the number of troubles in n circuits follows a Poisson distribution with mean λn where λ is the probability of a trouble in 1 circuit and n is the number of circuits.

In an adjustment cell, if the number of CLEC troubles is greater than 15 and the number of BST troubles is greater than 15, then the Z test is calculated using the normal approximation to the Poisson. In this case, the moments of the truncated Z come directly from properties of the standard normal distribution. Otherwise, if there are very few troubles, the number of CLEC troubles can be modeled using a binomial distribution with n equal to the total number of troubles (CLEC plus BST troubles.) In this case, the moments for the truncated Z are calculated explicitly using the binomial distribution.

Mean Measures

For mean measures, an adjusted t statistic is calculated for each like-to-like cell which has at least 7 BST and 7 CLEC transactions. A permutation test is used when one or both of the BST and CLEC sample sizes is less than 6. Both the adjusted t statistic and the permutation calculation are described in the technical appendix.

APPENDIX TECHNICAL DESCRIPTION

We start by assuming that any necessary trimming of the data is complete, and that the data are disaggregated so that comparisons are made within appropriate classes or adjustment cells that define “like” observations.

NOTATION AND EXACT TESTING DISTRIBUTIONS

Below, we have detailed the basic notation for the construction of the truncated z statistic. In what follows the word “cell” should be taken to mean a like-to-like comparison cell that has both one (or more) ILEC observation and one (or more) CLEC observation.

- L = the total number of occupied cells
 - j = 1, ..., L; an index for the cells
 - n_{1j} = the number of ILEC transactions in cell j
 - n_{2j} = the number of CLEC transactions in cell j
 - n_j = the total number transactions in cell j; $n_{1j} + n_{2j}$
 - X_{1jk} = individual ILEC transactions in cell j; $k = 1, \dots, n_{1j}$
 - X_{2jk} = individual CLEC transactions in cell j; $k = 1, \dots, n_{2j}$
 - Y_{jk} = individual transaction (both ILEC and CLEC) in cell j
- $$= \begin{cases} X_{1jk} & k = 1, \dots, n_{1j} \\ X_{2jk} & k = n_{1j} + 1, \dots, n_j \end{cases}$$

$\Phi^{-1}(\cdot)$ = the inverse of the cumulative standard normal distribution function

For Mean Performance Measures the following additional notation is needed.

- \bar{X}_{1j} = the ILEC sample mean of cell j
 - \bar{X}_{2j} = the CLEC sample mean of cell j
 - S_{1j}^2 = the ILEC sample variance in cell j
 - S_{2j}^2 = the CLEC sample variance in cell j
 - y_{jk} = a random sample of size n_{2j} from the set of Y_{j1}, \dots, Y_{jn_j} ; $k = 1, \dots, n_{2j}$
 - M_j = the total number of distinct pairs of samples of size n_{1j} and n_{2j} ;
- $$= \binom{n_j}{n_{1j}}$$

The exact parity test is the permutation test based on the “modified Z” statistic. For large samples, we can avoid permutation calculations since this statistic will be normal (or Student’s t) to a good approximation. For small samples, where we cannot avoid permutation calculations, we have found that the difference between “modified Z” and the textbook “pooled Z” is negligible. We therefore propose to use the permutation test based on pooled Z for small samples. This decision speeds up the permutation computations considerably, because for each permutation we need only compute the sum of the CLEC sample values, and not the pooled statistic itself.

A permutation probability mass function distribution for cell j, based on the “pooled Z” can be written as

$$PM(t) = P\left(\sum_k y_{jk} = t\right) = \frac{\text{the number of samples that sum to } t}{M_j},$$

and the corresponding cumulative permutation distribution is

$$CPM(t) = P\left(\sum_k y_{jk} \leq t\right) = \frac{\text{the number of samples with sum } \leq t}{M_j}.$$

For Proportion Performance Measures the following notation is defined

- a_{1j} = the number of ILEC cases possessing an attribute of interest in cell j
- a_{2j} = the number of CLEC cases possessing an attribute of interest in cell j
- a_j = the number of cases possessing an attribute of interest in cell j ; $a_{1j} + a_{2j}$

The exact distribution for a parity test is the hypergeometric distribution. The hypergeometric probability mass function distribution for cell j is

$$HG(h) = P(H = h) = \begin{cases} \frac{\binom{n_{1j}}{h} \binom{n_{2j}}{a_j - h}}{\binom{n_j}{a_j}}, & \max(0, a_j - n_{2j}) \leq h \leq \min(a_j, n_{1j}) \\ 0 & \text{otherwise} \end{cases},$$

and the cumulative hypergeometric distribution is

$$CHG(x) = P(H \leq x) = \begin{cases} 0 & x < \max(0, a_j - n_{1j}) \\ \sum_{h=\max(0, a_j - n_{1j})}^x HG(h), & \max(0, a_j - n_{1j}) \leq x \leq \min(a_j, n_{2j}) \\ 1 & x > \min(a_j, n_{2j}) \end{cases}.$$

For Rate Measures, the notation needed is defined as

- b_{1j} = the number of ILEC base elements in cell j
- b_{2j} = the number of CLEC base elements in cell j
- b_j = the total number of base elements in cell j ; $b_{1j} + b_{2j}$
- \bar{p}_{1j} = the ILEC sample rate of cell j ; n_{1j}/b_{1j}
- \bar{p}_{2j} = the CLEC sample rate of cell j ; n_{2j}/b_{2j}
- q_j = the relative proportion of CLEC elements for cell j ; b_{2j}/b_j

The exact distribution for a parity test is the binomial distribution. The binomial probability mass function distribution for cell j is

$$BN(k) = P(B = k) = \begin{cases} \binom{n_j}{k} q_j^k (1-q_j)^{n_j-k}, & 0 \leq k \leq n_j \\ 0 & \text{otherwise} \end{cases}$$

and the cumulative binomial distribution is

$$CBN(x) = P(B \leq x) = \begin{cases} 0 & x < 0 \\ \sum_{k=0}^x BN(k), & 0 \leq x \leq n_j \\ 1 & x > n_j \end{cases}$$

CALCULATING THE TRUNCATED Z

The general methodology for calculating an aggregate level test statistic is outlined below.

1. **Calculate cell weights, W_j .** A weight based on the number of transactions is used so that a cell which has a larger number of transactions has a larger weight. The actual weight formulae will depend on the type of measure.

Mean Measure

$$W_j = \sqrt{\frac{n_{1j}n_{2j}}{n_j}}$$

Proportion Measure

$$W_j = \sqrt{\frac{n_{2j}n_{1j}}{n_j} \cdot \frac{a_j}{n_j} \cdot \left(1 - \frac{a_j}{n_j}\right)}$$

Rate Measure

$$W_j = \sqrt{\frac{b_{1j}b_{2j}}{b_j} \cdot \frac{n_j}{b_j}}$$

2. **In each cell, calculate a Z value, Z_j .** A Z statistic with mean 0 and variance 1 is needed for each cell.

- If $W_j = 0$, set $Z_j = 0$.
- Otherwise, the actual Z statistic calculation depends on the type of performance measure.

Mean Measure

$$Z_j = \Phi^{-1}(\alpha)$$

where α is determine by the following algorithm.

If $\min(n_{1j}, n_{2j}) > 6$, then determine α as

$$\alpha = P(t_{n_j-1} \leq T_j),$$

that is, α is the probability that a t random variable with $n_{1j} - 1$ degrees of freedom, is less than

$$T_j = t_j + \frac{g}{6} \left(\frac{n_{1j} + 2n_{2j}}{\sqrt{n_{1j} n_{2j} (n_{1j} + n_{2j})}} \right) \left(t^2 + \frac{n_{2j} - n_{1j}}{2n_{1j} + n_{2j}} \right),$$

where

$$t_j = \frac{\bar{X}_{1j} - \bar{X}_{2j}}{s_{1j} \sqrt{\frac{1}{n_{1j}} + \frac{1}{n_{2j}}}}$$

and the coefficient g is an estimate of the skewness of the parent population, which we assume is the same in all cells. It can be estimated from the ILEC values in the largest cells. This needs to be done only once for each measure. We have found that attempting to estimate this skewness parameter for each cell separately leads to excessive variability in the "adjusted" t . We therefore use a single compromise value in all cells.

Note, that t_j is the "modified Z" statistic. The statistic T_j is a "modified Z" corrected for the skewness of the ILEC data.

If $\min(n_{1j}, n_{2j}) \leq 6$, and

a) $M_j \leq 1,000$ (the total number of distinct pairs of samples of size n_{1j} and n_{2j} is 1,000 or less).

- Calculate the sample sum for all possible samples of size n_{2j} .
- Rank the sample sums from smallest to largest. Ties are dealt by using average ranks.
- Let R_0 be the rank of the observed sample sum with respect all the sample sums.

$$\alpha = 1 - \frac{R_0 - 0.5}{M_j}$$

b) $M_j > 1,000$

- Draw a random sample of 1,000 sample sums from the permutation distribution.
- Add the observed sample sum to the list. There is a total of 1001 sample sums. Rank the sample sums from smallest to largest. Ties are dealt by using average ranks.
- Let R_0 be the rank of the observed sample sum with respect all the sample sums.

$$\alpha = 1 - \frac{R_0 - 0.5}{1001}.$$

Proportion Measure

$$Z_j = \frac{n_j a_{1j} - n_{1j} a_j}{\sqrt{\frac{n_{1j} n_{2j} a_j (n_j - a_j)}{n_j - 1}}}.$$

Rate Measure

$$Z_j = \frac{n_{1j} - n_j q_j}{\sqrt{n_j q_j (1 - q_j)}}.$$

3. **Obtain a truncated Z value for each cell, Z_j^* .** To limit the amount of cancellation that takes place between cell results during aggregation, cells whose results suggest possible favoritism are left alone. Otherwise the cell statistic is set to zero. This means that positive equivalent Z values are set to 0, and negative values are left alone. Mathematically, this is written as

$$Z_j^* = \min(0, Z_j).$$

4. **Calculate the theoretical mean and variance of the truncated statistic under the null hypothesis of parity, $E(Z_j^* | H_0)$ and $\text{Var}(Z_j^* | H_0)$.** In order to compensate for the truncation in step 3, an aggregated, weighted sum of the Z_j^* will need to be centered and scaled properly so that the final aggregate statistic follows a standard normal distribution.

- If $W_j = 0$, then no evidence of favoritism is contained in the cell. The formulae for calculating $E(Z_j^* | H_0)$ and $\text{Var}(Z_j^* | H_0)$ cannot be used. Set both equal to 0.
- If $\min(n_{1j}, n_{2j}) > 6$ for a mean measure, $\min\left\{a_{1j}\left(1 - \frac{a_{1j}}{n_{1j}}\right), a_{2j}\left(1 - \frac{a_{2j}}{n_{2j}}\right)\right\} > 9$ for a proportion measure, or $\min(n_{1j}, n_{2j}) > 15$ and $n_j q_j (1 - q_j) > 9$ for a rate measure then

$$E(Z_j^* | H_0) = -\frac{1}{\sqrt{2\pi}}, \text{ and}$$

$$\text{Var}(Z_j^* | H_0) = \frac{1}{2} - \frac{1}{2\pi}.$$

- Otherwise, determine the total number of values for Z_j^* . Let z_{ji} and θ_{ji} , denote the values of Z_j^* and the probabilities of observing each value, respectively.

$$E(Z_j^* | H_0) = \sum_i \theta_{ji} z_{ji}, \text{ and}$$

$$\text{Var}(Z_j^* | H_0) = \sum_i \theta_{ji} z_{ji}^2 - [E(Z_j^* | H_0)]^2.$$

The actual values of the z's and θ 's depends on the type of measure, and the sums in the equations are over all possible values of the index i.

Mean Measure

$$N_j = \min(M_j, 1,000), \quad i = 1, K, N_j$$

$$z_{ji} = \min \left\{ 0, 1 - \Phi^{-1} \left(\frac{R_i - 0.5}{N_j} \right) \right\} \quad \text{where } R_i \text{ is the rank of sample sum } i$$

$$\theta_j = \frac{1}{N_j}$$

Proportion Measure

$$z_{ji} = \min \left\{ 0, \frac{n_j i - n_{1j} a_j}{\sqrt{\frac{n_{1j} n_{2j} a_j (n_j - a_j)}{n_j - 1}}} \right\}, \quad i = \min(a_j, n_{2j}), K, \max(0, a_j - n_{1j})$$

$$\theta_{ji} = \text{HG}(i)$$

Rate Measure

$$z_{ji} = \min \left\{ 0, \frac{i - n_j q_j}{\sqrt{n_j q_j (1 - q_j)}} \right\}, \quad i = 0, K, n_j$$

$$\theta_{ji} = \text{BN}(i)$$

5. Calculate the aggregate test statistic, Z^T .

$$Z^T = \frac{\sum_j W_j Z_j^* - \sum_j W_j E(Z_j^* | H_0)}{\sqrt{\sum_j W_j^2 \text{Var}(Z_j^* | H_0)}}$$

The Balancing Critical Value

There are four key elements of the statistical testing process:

1. the null hypothesis, H_0 , that parity exists between ILEC and CLEC services
2. the alternative hypothesis, H_a , that the ILEC is giving better service to its own customers
3. the Truncated Z test statistic, Z^T , and
4. a critical value, c

The decision rule¹ is

- If $Z^T < c$ then accept H_a .
- If $Z^T \geq c$ then accept H_0 .

There are two types of error possible when using such a decision rule:

¹ This decision rule assumes that a negative test statistic indicates poor service for the CLEC customer. If the opposite is true, then reverse the decision rule.

Type I Error: Deciding favoritism exists when there is, in fact, no favoritism.
Type II Error: Deciding parity exists when there is, in fact, favoritism.

The probabilities of each type of each are:

Type I Error: $\alpha = P(Z^T < c | H_0)$.
Type II Error: $\beta = P(Z^T \geq c | H_a)$.

We want a balancing critical value, c_B , so that $\alpha = \beta$.

It can be shown that.

$$c_B = \frac{\sum_j W_j M(m_j, se_j) - \sum_j W_j \frac{-1}{\sqrt{2\pi}}}{\sqrt{\sum_j W_j^2 V(m_j, se_j) + \sum_j W_j^2 \left(\frac{1}{2} - \frac{1}{2\pi}\right)}}$$

where

$$M(\mu, \sigma) = \mu \Phi\left(\frac{-\mu}{\sigma}\right) - \sigma \phi\left(\frac{-\mu}{\sigma}\right)$$

$$V(\mu, \sigma) = (\mu^2 + \sigma^2) \Phi\left(\frac{-\mu}{\sigma}\right) - \mu \sigma \phi\left(\frac{-\mu}{\sigma}\right) - M(\mu, \sigma)^2$$

$\Phi(\cdot)$ is the cumulative standard normal distribution function, and $\phi(\cdot)$ is the standard normal density function.

This formula assumes that Z_j is approximately normally distributed within cell j . When the cell sample sizes, n_{1j} and n_{2j} , are small this may not be true. It is possible to determine the cell mean and variance under the null hypothesis when the cell sample sizes are small. It is much more difficult to determine these values under the alternative hypothesis. Since the cell weight, W_j will also be small (see calculate weights section above) for a cell with small volume, the cell mean and variance will not contribute much to the weighted sum. Therefore, the above formula provides a reasonable approximation to the balancing critical value.

The values of m_j and se_j will depend on the type of performance measure.

Mean Measure

For mean measures, one is concerned with two parameters in each cell, namely, the mean and variance. A possible lack of parity may be due to a difference in cell means, and/or a difference in cell variances. One possible set of hypotheses that capture this notion, and take into account the assumption that transaction are identically distributed within cells is:

$$H_0: \mu_{1j} = \mu_{2j}, \sigma_{1j}^2 = \sigma_{2j}^2$$

$$H_a: \mu_{2j} = \mu_{1j} + \delta_j \cdot \sigma_{1j}, \sigma_{2j}^2 = \lambda_j \cdot \sigma_{1j}^2 \quad \delta_j > 0, \lambda_j \geq 1 \text{ and } j = 1, \dots, L.$$

Under this form of alternative hypothesis, the cell test statistic Z_j has mean and standard error given by

$$m_j = \frac{-\delta_j}{\sqrt{\frac{1}{n_{1j}} + \frac{1}{n_{2j}}}}, \text{ and}$$

$$se_j = \sqrt{\frac{\lambda_j n_{1j} + n_{2j}}{n_{1j} + n_{2j}}}$$

Proportion Measure

For a proportion measure there is only one parameter of interest in each cell, the proportion of transaction possessing an attribute of interest. A possible lack of parity may be due to a difference in cell proportions. A set of hypotheses that take into account the assumption that transaction are identically distributed within cells while allowing for an analytically tractable solution is:

$$H_0: \frac{p_{2j}(1-p_{1j})}{(1-p_{2j})p_{1j}} = 1$$

$$H_a: \frac{p_{2j}(1-p_{1j})}{(1-p_{2j})p_{1j}} = \psi_j \quad \psi_j > 1 \text{ and } j = 1, \dots, L.$$

These hypotheses are based on the “odds ratio.” If the transaction attribute of interest is a missed trouble repair, then an interpretation of the alternative hypothesis is that a CLEC trouble repair appointment is ψ_j times more likely to be missed than an ILEC trouble.

Under this form of alternative hypothesis, the within cell asymptotic mean and variance of a_{1j} are given by²

$$E(a_{1j}) = n_j \pi_j^{(1)}$$

$$\text{var}(a_{1j}) = \frac{n_j}{\frac{1}{\pi_j^{(1)}} + \frac{1}{\pi_j^{(2)}} + \frac{1}{\pi_j^{(3)}} + \frac{1}{\pi_j^{(4)}}}$$

where

² Stevens, W. L. (1951) Mean and Variance of an entry in a Contingency Table. *Biometrika*, **38**, 468-470.

$$\begin{aligned}\pi_j^{(1)} &= f_j^{(1)} \left(n_j^2 + f_j^{(2)} + f_j^{(3)} - f_j^{(4)} \right) \\ \pi_j^{(2)} &= f_j^{(1)} \left(-n_j^2 - f_j^{(2)} + f_j^{(3)} + f_j^{(4)} \right) \\ \pi_j^{(3)} &= f_j^{(1)} \left(-n_j^2 + f_j^{(2)} - f_j^{(3)} + f_j^{(4)} \right) \\ \pi_j^{(4)} &= f_j^{(1)} \left(n_j^2 \left(\frac{2}{\psi_j} - 1 \right) - f_j^{(2)} - f_j^{(3)} - f_j^{(4)} \right) \\ f_j^{(1)} &= \frac{1}{2n_j^2 \left(\frac{1}{\psi_j} - 1 \right)} \\ f_j^{(2)} &= n_j n_{1j} \left(\frac{1}{\psi_j} - 1 \right) \\ f_j^{(3)} &= n_j a_j \left(\frac{1}{\psi_j} - 1 \right) \\ f_j^{(4)} &= \sqrt{n_j^2 \left[4n_{1j} (n_j - a_j) \left(\frac{1}{\psi_j} - 1 \right) + \left(n_j + (a_j - n_{1j}) \left(\frac{1}{\psi_j} - 1 \right) \right)^2 \right]}\end{aligned}$$

Recall that the cell test statistic is given by

$$Z_j = \frac{n_j a_{1j} - n_{1j} a_j}{\sqrt{\frac{n_{1j} n_{2j} a_j (n_j - a_j)}{n_j - 1}}}$$

Using the equations above, we see that Z_j has mean and standard error given by

$$\begin{aligned}m_j &= \frac{n_j^2 \pi_j^{(1)} - n_{1j} a_j}{\sqrt{\frac{n_{1j} n_{2j} a_j (n_j - a_j)}{n_j - 1}}}, \text{ and} \\ se_j &= \sqrt{\frac{n_j^3 (n_j - 1)}{n_{1j} n_{2j} a_j (n_j - a_j) \left(\frac{1}{\pi_j^{(1)}} + \frac{1}{\pi_j^{(2)}} + \frac{1}{\pi_j^{(3)}} + \frac{1}{\pi_j^{(4)}} \right)}}.\end{aligned}$$

Rate Measure

A rate measure also has only one parameter of interest in each cell, the rate at which a phenomenon is observed relative to a base unit, e.g. the number of troubles per available line. A possible lack of parity may be due to a difference in cell rates. A set of hypotheses that take into account the assumption that transaction are identically distributed within cells is:

$$H_0: r_{1j} = r_{2j}$$

$$H_a: r_{2j} = \epsilon_j r_{1j} \quad \epsilon_j > 1 \text{ and } j = 1, \dots, L.$$

Given the total number of ILEC and CLEC transactions in a cell, n_j , and the number of base elements, b_{1j} and b_{2j} , the number of ILEC transaction, n_{1j} , has a binomial distribution from n_j trials and a probability of

$$q_j^* = \frac{r_{1j} b_{1j}}{r_{1j} b_{1j} + r_{2j} b_{2j}}.$$

Therefore, the mean and variance of n_{1j} , are given by

$$\begin{aligned} E(n_{1j}) &= n_j q_j^* \\ \text{var}(n_{1j}) &= n_j q_j^* (1 - q_j^*) \end{aligned}$$

Under the null hypothesis

$$q_j^* = q_j = \frac{b_{1j}}{b_j},$$

but under the alternative hypothesis

$$q_j^* = q_j^a = \frac{b_{1j}}{b_{1j} + \varepsilon_j b_{2j}}.$$

Recall that the cell test statistic is given by

$$Z_j = \frac{n_{1j} - n_j q_j}{\sqrt{n_j q_j (1 - q_j)}}.$$

Using the relationships above, we see that Z_j has mean and standard error given by

$$\begin{aligned} m_j &= \frac{n_j (q_j^a - q_j)}{\sqrt{n_j q_j (1 - q_j)}} = (1 - \varepsilon_j) \sqrt{\frac{n_j b_{1j} b_{2j}}{b_{1j} + \varepsilon_j b_{2j}}}, \text{ and} \\ \text{se}_j &= \sqrt{\frac{q_j^a (1 - q_j^a)}{q_j (1 - q_j)}} = \sqrt{\varepsilon_j} \frac{b_j}{b_{1j} + \varepsilon_j b_{2j}}. \end{aligned}$$

Determining the Parameters of the Alternative Hypothesis

In this appendix we have indexed the alternative hypothesis of mean measures by two sets of parameters, λ_j and δ_j . Proportion and rate measures have been indexed by one set of parameters each, ψ_j and ε_j respectively. While statistical science can be used to evaluate the impact of different choices of these parameters, there is not much that an appeal to statistical principles can offer in directing specific choices. Specific choices are best left to telephony experts. Still, it is possible to comment on some aspects of these choices:

- Parameter Choices for λ_j . The set of parameters λ_j index alternatives to the null hypothesis that arise because there might be greater unpredictability or variability in the delivery of service to a CLEC customer over that which would be achieved for an otherwise comparable ILEC customer. While concerns about differences in the variability of service are important, it turns out that the truncated Z testing which is being recommended here is relatively insensitive to all but very large values of the λ_j . Put another way, reasonable differences in the values chosen here could make very little difference in the balancing points chosen.

- Parameter Choices for δ_j . The set of parameters δ_j are much more important in the choice of the balancing point than was true for the λ_j . The reason for this is that they directly index differences in average service. The truncated Z test is very sensitive to any such differences; hence, even small disagreements among experts in the choice of the δ_j could be very important. Sample size matters here too. For example, setting all the δ_j to a single value – $\delta_j = \delta$ – might be fine for tests across individual CLECs where currently in Louisiana the CLEC customer bases are not too different. Using the same value of δ for the overall state testing does not seem sensible, however, since the state sample would be so much larger.
- Parameter Choices for ψ_j or ϵ_j . The set of parameters ψ_j or ϵ_j are also important in the choice of the balancing point for tests of their respective measures. The reason for this is that they directly index increases in the proportion or rate of service performance. The truncated Z test is sensitive to such increases; but not as sensitive as the case of δ_j for mean measures. Sample size matters here as well. As with mean measures, using the same value of ψ or ϵ for the overall state testing does not seem sensible since the state sample would be so much larger.

The bottom line here is that beyond a few general considerations, like those given above, a principled approach to the choice of the alternative hypotheses to guard against, must come from elsewhere.

DECISION PROCESS

Once Z^T has been calculated, it is compared to the balancing critical value to determine if the ILEC is favoring its own customers over a CLEC's customers.

This critical value changes as the ILEC and CLEC transaction volume change. One way to make this transparent to the decision maker, is to report the difference between the test statistic and the critical value, $diff = Z^T - c_B$. If favoritism is concluded when $Z^T < c_B$, then the $diff < 0$ indicates favoritism.

This make it very easy to determine favoritism: a positive $diff$ suggests no favoritism, and a negative $diff$ suggests favoritism.

EXHIBIT D

BST VSEEM REMEDY PROCEDURE

TIER-1 CALCULATION FOR RETAIL ANALOGUES:

1. Calculate the overall test statistic for each CLEC; z^T_{CLEC1} (See Exhibit C)
2. Calculate the balancing critical value ($C_{B_{CLEC1}}$) that is associated with the alternative hypothesis (for fixed parameters δ, ψ or ϵ). (See Exhibit C)
3. If the overall test statistic is equal to or above the balancing critical value, stop here. Otherwise, go to step 4.
4. Calculate the Parity Gap by subtracting the value of step 2. from that of step 1.;
 $z^T_{CLEC1} - C_{B_{CLEC1}}$
5. Calculate the Volume Proportion using a linear distribution with slope of $\frac{1}{4}$. This can be accomplished by taking the absolute value of the Parity Gap from step 4. divided by 4;
 $ABS((z^T_{CLEC1} - C_{B_{CLEC1}}) / 4)$. All parity gaps equal or greater to 4 will result in a volume proportion of 100%.
6. Calculate the Affected Volume by multiplying the Volume Proportion from step 5. by the Total CLEC₁ Volume in the negatively affected cell; where the cell value is negative. (See Exhibit C)
7. Calculate the payment to Level 3 by multiplying the result of step 6. by the appropriate dollar amount from the fee schedule.

So, Level 3 payment = Affected Volume_{CLEC1} * \$\$ from Fee Schedule

Example: Level 3 Missed Installation Appointments (MIA) for Resale POTS

	n_i	n_c	MIA_i	MIA_c	z^T_{CLEC1}	C_B	Parity Gap	Volume Proportion	Affected Volume
State	50000	600	9%	16%	-1.92	-0.21	1.71	0.4275	
Cell					<u>z_{CLEC1}</u>				
1		150	0.091	0.112	-1.994				64
2		75	0.176	0.098	0.734				
3		10	0.128	0.333	-2.619				4
4		50	0.158	0.242	-2.878				21
5		15	0.245	0.075	1.345				
6		200	0.156	0.130	0.021				
7		30	0.166	0.233	-0.600				13
8		20	0.106	0.127	-0.065				9
9		40	0.193	0.218	-0.918				17
10		10	0.160	0.235	-0.660				4
									133

where n_i = ILEC observations and n_c = Level 3 observations

Payout for Level 3 is (133 units) * (\$100/unit) = \$13,300

TIER-2 CALCULATION for RETAIL ANALOGUES:

1. Tier-2 is triggered by three monthly failures of any VSEEM submetric in the same quarter.
2. Calculate the overall test statistic for the CLEC Aggregate using all transactions from the calendar quarter; z_{CLECA}^T
3. Calculate the balancing critical value ($C_{B_{CLECA}}$) that is associated with the alternative hypothesis (for fixed parameters δ , ψ or ϵ). (See Exhibit C)
4. If the overall test statistic is equal to or above the balancing critical value for the calendar quarter, stop here. Otherwise, go to step 5.
5. Calculate the Parity Gap by subtracting the value of step 3. from that of step 2.;
 $z_{CLECA}^T - C_{B_{CLECA}}$
6. Calculate the Volume Proportion using a linear distribution with slope of $\frac{1}{4}$. This can be accomplished by dividing the Parity Gap from step 5. by 4; $ABS((z_{CLECA}^T - C_{B_{CLECA}}) / 4)$. All parity gaps equal or greater to 4 will result in a volume proportion of 100%.
7. Calculate the Affected Volume by multiplying the Volume Proportion from step 6. by the Total $CLECA_A$ Volume (CLEC Aggregate) in the negatively affected cell; where the cell value is negative (See Exhibit C).
8. Calculate the payment to State Designated Agency by multiplying the result of step 7. by the appropriate dollar amount from the fee schedule.

So, State Designated Agency payment = Affected Volume_{CLECA} * \$\$ from Fee Schedule

Example: CLEC-A Missed Installation Appointments (MIA) for Resale POTS

State Quarter	n_I	n_C	MIA_I	MIA_C	z_{CLECA}^T	C_B	Parity Gap	Volume Proportion	Affected Volume
1	180000	2100	9%	16%	-1.92	-0.21	1.71	0.4275	
Cell					<u>z_{CLECA}</u>				
1		500	0.091	0.112	-1.994				214
2		300	0.176	0.098	0.734				
3		80	0.128	0.333	-2.619				34
4		205	0.158	0.242	-2.878				88
5		45	0.245	0.075	1.345				
6		605	0.156	0.130	0.021				
7		80	0.166	0.233	-0.600				34
8		40	0.106	0.127	-0.065				17

9	165	0.193	0.218	-0.918
10	80	0.160	0.235	-0.660

71
34
<hr/> 492

where n_i = ILEC observations and n_c = CLEC-A observations

Payout for CLEC-A is (492 units) * (\$300/unit) = \$147,600

Tier-3

Tier-3 uses the monthly CLEC Aggregate results in a given State. Tier-3 is triggered when five of the twelve Tier-3 sub-metrics experience consecutive failures in a given calendar quarter. The table below displays a situation that would trigger a Tier-3 failure, and one that would not.

Process	Measures	TIER-3 FAILURE X = Miss			NOT A TIER-3 FAILURE X = Miss		
		Jan	Feb	Mar	Jan	Feb	Mar
Percent Missed Installation Appointments	Resale POTS	X	X	X	X		
	Resale Design	X			X	X	X
	UNE Loop & Port Combo		X				
	UNE Loops	X	X	X			
Percent Missed Repair Appointments	Resale POTS	X	X	X	X		X
	Resale Design		X	X		X	
	UNE Loop & Port Combo					X	X
	UNE Loops				X		
Billing	Billing Accuracy	X	X	X			
	Billing Timeliness				X	X	X
Trunk Blockage	Percent Trunk Blockage	X	X	X			
Collocation	Percent Missed Collocation Due Dates						

Tier-3 is effective immediately after quarter results, and can only be lifted when two of the five failed sub-metrics show compliance for two consecutive months in the following quarter.

All tiers standalone, such that triggering Tier-3 will not cease payout of any Tier-1 or Tier-2 failures.

TIER-1 CALCULATION FOR BENCHMARKS:

1. For each CLEC, with five or more observations, calculate monthly performance results for the State.
2. CLECs having observations (sample sizes) between 5 and 30 will use Table I below:

TABLE I SMALL SAMPLE SIZE TABLE
(95% Confidence)

Sample Size	Equivalent 90% Benchmark	Equivalent 95% Benchmark	Sample Size	Equivalent 90% Benchmark	Equivalent 95% Benchmark
5	60.00%	80.00%	16	75.00%	87.50%
6	66.67%	83.33%	17	76.47%	82.35%
7	71.43%	85.71%	18	77.78%	83.33%
8	75.00%	75.00%	19	78.95%	84.21%
9	66.67%	77.78%	20	80.00%	85.00%
10	70.00%	80.00%	21	76.19%	85.71%
11	72.73%	81.82%	22	77.27%	86.36%
12	75.00%	83.33%	23	78.26%	86.96%
13	76.92%	84.62%	24	79.17%	87.50%
14	78.57%	85.71%	25	80.00%	88.00%
15	73.33%	86.67%	26	80.77%	88.46%
			27	81.48%	88.89%
			28	78.57%	89.29%
			29	79.31%	86.21%
			30	80.00%	86.67%

3. If the percentage (or equivalent percentage for small samples) is equal to or below the benchmark standard, stop here. Otherwise, go to step 4.
4. Determine the Volume Proportion by taking the difference between the benchmark and the actual performance result.
5. Calculate the Affected Volume by multiplying the Volume Proportion from step 4. by the Total CLEC₁ Volume.
6. Calculate the payment to Level 3 by multiplying the result of step 5. by the appropriate dollar amount from the fee schedule.

So, Level 3 payment = Affected Volume_{CLEC1} * \$\$ from Fee Schedule

Example: Level 3 Missed Installation Appointments (MIA) for UNE Loops

	n_c	Benchmark	MIA_c	Volume Proportion	Affected Volume
State	600	9%	12%	.03	18

Payout for Level 3 is (18 units) * (\$400/unit) = \$7,200

TIER-1 CALCULATION FOR BENCHMARKS (IN THE FORM OF A TARGET):

1. For each, with five or more observations, CLEC calculate monthly performance results for the State.
2. CLECs having observations (sample sizes) between 5 and 30 will use Table I above.
3. Calculate the interval distribution based on the same data set used in step 1.
4. If the 'percent within' is equal to or exceeds the benchmark standard, stop here. Otherwise, go to step 5.
5. Determine the Volume Proportion by taking the difference between 100% and the actual performance result.
6. Calculate the Affected Volume by multiplying the Volume Proportion from step 5. by the Total CLEC₁ Volume.
7. Calculate the payment to Level 3 by multiplying the result of step 6. by the appropriate dollar amount from the fee schedule.

So, Level 3 payment = Affected Volume_{CLEC1} * \$\$ from Fee Schedule

Example: Level 3 Reject Timeliness

	n_c	Benchmark	Reject Timeliness _c	Volume Proportion	Affected Volume
State	600	95% within 1 hour	93% within 1 hour	.07	42

Payout for Level 3 is (42 units) * (\$100/unit) = \$4,200

TIER-2 CALCULATIONS for BENCHMARKS:

Tier-2 calculations for benchmark measures are the same as the Tier-1 benchmark calculations except the CLEC Aggregate data having failed for three months in a given calendar quarter is being assessed.

EXHIBIT E

Table-1

LIQUIDATED DAMAGES TABLE FOR TIER-1 MEASURES

PER AFFECTED ITEM						
	Month 1	Month 2	Month3	Month4	Month 5	Month 6
Ordering	\$40	\$50	\$60	\$70	\$80	\$90
Provisioning	\$100	\$125	\$175	\$250	\$325	\$500
Provisioning UNE (Coordinated Customer Conversions)	\$400	\$450	\$500	\$550	\$650	\$800
Maintenance and Repair	\$100	\$125	\$175	\$250	\$325	\$500
Maintenance and Repair UNE	\$400	\$450	\$500	\$550	\$650	\$800
LNP	\$150	\$250	\$500	\$600	\$700	\$800
IC Trunks	\$100	\$125	\$175	\$250	\$325	\$500
Collocation	\$5,000	\$5,000	\$5,000	\$5,000	\$5,000	\$5,000

Table-2

VOLUNTARY PAYMENTS FOR TIER-2 MEASURES

	Per Affected Item
OSS Pre-Ordering	\$20
Ordering	\$60
Provisioning	\$300
UNE Provisioning (Coordinated Customer Conversions)	\$875
Maintenance and Repair	\$300
UNE Maintenance and Repair	\$875
Billing	\$1.00
LNP	\$500
IC Trunks	\$500
Collocation	\$15,000

**AGREEMENT IMPLEMENTATION TEMPLATE (Residence)
for
Level3
BellSouth Standard Interconnection Agreement**

Agreement Effective Date:	Agreement Expiration Date:
Account Manager:	Account Manager Tel No:

Attachment Name/Number	Section Number	Version Date	Planned Activities
Terms/Conditions PartA	1		
	2		
	3		
	4		
	5		
	6		
	7		
	8		
	9		
	10		
	11		
	12		
	13		
	14		
	15		
	16		
	17		
	18		
	19		
	20		
	21		
	22		
	23		
	24		
	25		
	26		
Terms/Conditions Part B			

**AGREEMENT IMPLEMENTATION TEMPLATE (Residence)
for
Level3
BellSouth Standard Interconnection Agreement**

Attachment Name/Number	Section Number	Version Date	Planned Activities
1-Resale	1		
	2		
	3		
	4		
	5		
	6		
	7		
	8		
	9		
	10		
	11		
	12		
	13		
	Exhibit A		
	Exhibit B		
	Exhibit C		
	Exhibit D		
	Exhibit E		
	Exhibit F		
	Exhibit G		
	Exhibit H		
2-Network Elements & Other Services	1		
	2		
	3		
	4		
	5		
	6		
	7		
	8		
	9		

**AGREEMENT IMPLEMENTATION TEMPLATE (Residence)
for
Level3
BellSouth Standard Interconnection Agreement**

Attachment Name/Number	Section Number	Version Date	Planned Activities
	10		
	11		
	12		
	13		
	14		
	15		
	16		
	17		
	Exhibit A		
	Exhibit B		
	Exhibit C		
3-Local Interconnection	1		
	2		
	3		
	4		
	5		
	6		
	7		
	8		
	Exhibit A		
4-Physical Collocation	1		
	2		
	3		
	4		
	5		
	6		
	7		
	8		
	9		
	10		

**AGREEMENT IMPLEMENTATION TEMPLATE (Residence)
for
Level3
BellSouth Standard Interconnection Agreement**

Attachment Name/Number	Section Number	Version Date	Planned Activities
	11		
	12		
	13		
	14		
	Exhibit A		
	Exhibit B		
5-Access to Numbers & Number Portability	1		
	2		
	3		
	4		
	5		
	6		
	7		
	8		
	Exhibit A		
6-Ordering/Provisioning	1		
	2		
	3		
7-Billing & Billing Accuracy Certification	1		
	2		
	3		
	4		
	5		
	6		
	7		
	Exhibit A		
8-ROW/Conduits/PoleAtt	1		
9-Perf Measurement	Pre-Ordering		
	Ordering		

**AGREEMENT IMPLEMENTATION TEMPLATE (Residence)
for
Level3
BellSouth Standard Interconnection Agreement**

Attachment Name/Number	Section Number	Version Date	Planned Activities
	Provisioning		
	Maint/Repair		
	Billing		
	Opr Svcs/DA		
	E911		
	Trunk Grp Perf		
	Collocation		
	Appendix A		
	Appendix B		
	Appendix C		

**AGREEMENT IMPLEMENTATION TEMPLATE (Business)
for
Level3
BellSouth Standard Interconnection Agreement**

Agreement Effective Date:	Agreement Expiration Date:
Account Manager:	Account Manager Tel No:

Attachment Name	Section No.	Version Date	Planned Activities
Terms/Conditions PartA	1		
	2		
	3		
	4		
	5		
	6		
	7		
	8		
	9		
	10		
	11		
	12		
	13		
	14		
	15		
	16		
	17		
	18		
	19		
	20		
	21		
	22		
	23		
	24		
	25		
	26		
Terms/Conditions Part B			

AGREEMENT IMPLEMENTATION TEMPLATE (Business)
for
Level3
BellSouth Standard Interconnection Agreement

Attachment Name	Section No.	Version Date	Planned Activities
1-Resale	1		
	2		
	3		
	4		
	5		
	6		
	7		
	8		
	9		
	10		
	11		
	12		
	13		
	Exhibit A		
	Exhibit B		
	Exhibit C		
	Exhibit D		
	Exhibit E		
	Exhibit F		
	Exhibit G		
	Exhibit H		
2-Network Elements & Other Services	1		
	2		
	3		
	4		
	5		
	6		
	7		
	8		
	9		

AGREEMENT IMPLEMENTATION TEMPLATE (Business)
for
Level3
BellSouth Standard Interconnection Agreement

Attachment Name	Section No.	Version Date	Planned Activities
	10		
	11		
	12		
	13		
	14		
	15		
	16		
	17		
	Exhibit A		
	Exhibit B		
	Exhibit C		
3-Local Interconnection	1		
	2		
	3		
	4		
	5		
	6		
	7		
	8		
	Exhibit A		
4-Physical Collocation	1		
	2		
	3		
	4		
	5		
	6		
	7		
	8		
	9		
	10		

AGREEMENT IMPLEMENTATION TEMPLATE (Business)
for
Level3
BellSouth Standard Interconnection Agreement

Attachment Name	Section No.	Version Date	Planned Activities
	11		
	12		
	13		
	14		
	Exhibit A		
	Exhibit B		
5-Access to Numbers & Number Portability	1		
	2		
	3		
	4		
	5		
	6		
	7		
	8		
	Exhibit A		
6-Ordering/Provisioning	1		
	2		
	3		
7-Billing & Billing Accuracy Certification	1		
	2		
	3		
	4		
	5		
	6		
	7		
	Exhibit A		
8-ROW/Conduits/PoleAtt	1		
9-Perf Measurement	Pre-Ordering		
	Ordering		

AGREEMENT IMPLEMENTATION TEMPLATE (Business)
for
Level3
BellSouth Standard Interconnection Agreement

Attachment Name	Section No.	Version Date	Planned Activities
	Provisioning		
	Maint/Repair		
	Billing		
	Opr Svcs/DA		
	E911		
	Trunk Grp Perf		
	Collocation		
	Appendix A		
	Appendix B		
	Appendix C		

Attachment 11 BellSouth Disaster Recovery Plan

The attached BellSouth Disaster Recovery Plan is for the state of Tennessee. The BellSouth Disaster Recovery Plan for the remaining states can be accessed via the internet @ <http://www.interconnection.bellsouth.com>.

***2000
BELLSOUTH
TENNESSEE
DISASTER RECOVERY PLANNING***

For

CLECS

CONTENTS

	<u>PAGE</u>
1.0 Purpose	4
2.0 Single Point of Contact	4
3.0 Identifying the Problem	4
3.1 Site Control	5
3.2 Environmental Concerns	6
4.0 The Emergency Control Center (ECC)	6
5.0 Recovery Procedures	7
5.1 CLEC Outage	7
5.2 BellSouth Outage	7
5.2.1 Loss of Central Office	8
5.2.2 Loss of a Central Office with Serving Wire Center Functions	8
5.2.3 Loss of a Central Office with Tandem Functions	8
5.2.4 Loss of a Facility Hub	9
5.3 Combined Outage (CLEC and BellSouth Equipment)	9
6.0 T1 Identification Procedures	9
7.0 Acronyms	10

1.0 PURPOSE

In the unlikely event of a disaster occurring that affects BellSouth's long-term ability to deliver traffic to a Competitive Local Exchange Carrier (CLEC), general procedures have been developed to hasten the recovery process. Since each location is different and could be affected by an assortment of potential problems, a detailed recovery plan is impractical. However, in the process of reviewing recovery activities for specific locations, some basic procedures emerge that appear to be common in most cases.

These general procedures should apply to any disaster that affects the delivery of traffic for an extended time period. Each CLEC will be given the same consideration during an outage and service will be restored as quickly as possible.

This document will cover the basic recovery procedures that would apply to every CLEC.

2.0 SINGLE POINT OF CONTACT

When a problem is experienced, regardless of the severity, the BellSouth Network Management Center (NMC) will observe traffic anomalies and begin monitoring the situation. Controls will be appropriately applied to insure the sanity of BellSouth's network; and, in the event that a switch or facility node is lost, the NMC will attempt to circumvent the failure using available reroutes.

BellSouth's NMC will remain in control of the restoration efforts until the problem has been identified as being a long-term outage. At that time, the NMC will contact BellSouth's Emergency Control Center (ECC) and relinquish control of the recovery efforts. Even though the ECC may take charge of the situation, the NMC will continue to monitor the circumstances and restore traffic as soon as damaged network elements are revitalized.

The telephone number for the BellSouth Network Management Center in Atlanta, as published in Telcordia's National Network Management Directory, is 404-321-2516.

3.0 IDENTIFYING THE PROBLEM

During the early stages of problem detection, the NMC will be able to tell which CLECs are affected by the catastrophe. Further analysis and/or first hand observation will determine if the disaster has affected CLEC equipment only; BellSouth equipment only or a combination. The initial restoration activity will be largely determined by the equipment that is affected.

Once the nature of the disaster is determined and after verifying the cause of the problem, the NMC will initiate reroutes and/or transfers that are jointly agreed upon by the affected CLECs' Network Management Center and the BellSouth NMC. The type and percentage of controls used will depend upon available network capacity. Controls necessary to stabilize the situation will be invoked and the NMC will attempt to re-establish as much traffic as possible.

For long term outages, recovery efforts will be coordinated by the Emergency Control Center (ECC). Traffic controls will continue to be applied by the NMC until facilities are re-established. As equipment is made available for service, the ECC will instruct the NMC to begin removing the controls and allow traffic to resume.

3.1 SITE CONTROL

In the total loss of building use scenario, what likely exists will be a smoking pile of rubble. This rubble will contain many components that could be dangerous. It could also contain any personnel on the premises at the time of the disaster. For these reasons, the local fire marshal with the assistance of the police will control the site until the building is no longer a threat to surrounding properties and the companies have secured the site from the general public.

During this time, the majority owner of the building should be arranging for a demolition contractor to mobilize to the site with the primary objective of reaching the cable entrance facility for a damage assessment. The results of this assessment would then dictate immediate plans for restoration, both short term and permanent.

In a less catastrophic event, i.e., the building is still standing and the cable entrance facility is usable, the situation is more complex. The site will initially be controlled by local authorities until the threat to adjacent property has diminished. Once the site is returned to the control of the companies, the following events should occur.

An initial assessment of the main building infrastructure systems (mechanical, electrical, fire and life safety, elevators, and others) will establish building needs. Once these needs are determined, the majority owner should lead the building restoration efforts. There may be situations where the site will not be totally restored within the confines of the building. The companies must individually determine their needs and jointly assess the cost of permanent restoration to determine the overall plan of action.

Multiple restoration trailers from each company will result in the need for designated space and installation order. This layout and control is required to maximize the amount of restoration equipment that can be placed at the site, and the priority of placements.

Care must be taken in this planning to insure other restoration efforts have logistical access to the building. Major components of telephone and building equipment will need to be removed and replaced. A priority for this equipment must also be jointly established to facilitate overall site restoration. (Example: If the AC switchgear has sustained damage, this would be of the highest priority in order to regain power, lighting, and HVAC throughout the building.)

If the site will not accommodate the required restoration equipment, the companies would then need to quickly arrange with local authorities for street closures, rights of way or other possible options available.

3.2 ENVIRONMENTAL CONCERNS

In the worse case scenario, many environmental concerns must be addressed. Along with the police and fire marshal, the state environmental protection department will be on site to monitor the situation.

Items to be concerned with in a large central office building could include:

1. Emergency engine fuel supply. Damage to the standby equipment and the fuel handling equipment could have created "spill" conditions that have to be handled within state and federal regulations.
2. Asbestos containing materials that may be spread throughout the wreckage. Asbestos could be in many components of building, electrical, mechanical, outside plant distribution, and telephone systems.
3. Lead and acid. These materials could be present in potentially large quantities depending upon the extent of damage to the power room.
4. Mercury and other regulated compounds resident in telephone equipment.
5. Other compounds produced by the fire or heat.

Once a total loss event occurs at a large site, local authorities will control immediate clean up (water placed on the wreckage by the fire department) and site access.

At some point, the companies will become involved with local authorities in the overall planning associated with site clean up and restoration. Depending on the clean up approach taken, delays in the restoration of several hours to several days may occur.

In a less severe disaster, items listed above are more defined and can be addressed individually depending on the damage.

In each case, the majority owner should coordinate building and environmental restoration as well as maintain proper planning and site control.

4.0 THE EMERGENCY CONTROL CENTER (ECC)

The ECC is located in the Colonnade Building in Birmingham, Alabama. During an emergency, the ECC staff will convene a group of pre-selected experts to inventory the damage and initiate corrective actions. These experts have regional access to BellSouth's personnel and equipment and will assume control of the restoration activity anywhere in the nine-state area.

In the past, the ECC has been involve with restoration activities resulting from hurricanes, ice storms and floods. They have demonstrated their capabilities during these calamities as well as

during outages caused by human error or equipment failures. This group has an excellent record of restoring service as quickly as possible.

During a major disaster, the ECC may move emergency equipment to the affected location, direct recovery efforts of local personnel and coordinate service restoration activities with the CLECs. The ECC will attempt to restore service as quickly as possible using whatever means is available; leaving permanent solutions, such as the replacement of damaged buildings or equipment, for local personnel to administer.

Part of the ECC's responsibility, after temporary equipment is in place, is to support the NMC efforts to return service to the CLECs. Once service has been restored, the ECC will return control of the network to normal operational organizations. Any long-term changes required after service is restored will be made in an orderly fashion and will be conducted as normal activity.

5.0 RECOVERY PROCEDURES

The nature and severity of any disaster will influence the recovery procedures. One crucial factor in determining how BellSouth will proceed with restoration is whether or not BellSouth's equipment is incapacitated. Regardless of who's equipment is out of service, BellSouth will move as quickly as possible to aid with service recovery; however, the approach that will be taken may differ depending upon the location of the problem.

5.1 CLEC OUTAGE

For a problem limited to one CLEC (or a building with multiple CLECs), BellSouth has several options available for restoring service quickly. For those CLECs that have agreements with other CLECs, BellSouth can immediately start directing traffic to a provisional CLEC for completion. This alternative is dependent upon BellSouth having concurrence from the affected CLECs.

Whether or not the affected CLECs have requested a traffic transfer to another CLEC will not impact BellSouth's resolve to re-establish traffic to the original destination as quickly as possible.

5.2 BELLSOUTH OUTAGE

Because BellSouth's equipment has varying degrees of impact on the service provided to the CLECs, restoring service from damaged BellSouth equipment is different. The outage will probably impact a number of Carriers simultaneously. However, the ECC will be able to initiate immediate actions to correct the problem.

A disaster involving any of BellSouth's equipment locations could impact the CLECs, some more than others. A disaster at a Central Office (CO) would only impact the delivery of traffic to and from that one location, but the incident could affect many Carriers. If the Central Office is a Serving Wire Center (SWC), then traffic from the entire area to those Carriers served from that switch would also be impacted. If the switch functions as an Access Tandem, or there is a tandem in the building, traffic from every CO to every CLEC could be interrupted. A disaster that destroys a facility hub could disrupt various traffic flows, even though the switching equipment may be unaffected.

The NMC would be the first group to observe a problem involving BellSouth's equipment. Shortly after a disaster, the NMC will begin applying controls and finding re-routes for the

completion of as much traffic as possible. These reroutes may involve delivering traffic to alternate Carriers upon receiving approval from the CLECs involved. In some cases, changes in translations will be required. If the outage is caused by the destruction of equipment, then the ECC will assume control of the restoration.

5.2.1 Loss of a Central Office

When BellSouth loses a Central Office, the ECC will

- a) Place specialists and emergency equipment on notice;
- b) Inventory the damage to determine what equipment and/or functions are lost;
- c) Move containerized emergency equipment and facility equipment to the stricken area, if necessary;
- d) Begin reconnecting service for Hospitals, Police and other emergency agencies; and
- e) Begin restoring service to CLECs and other customers.

5.2.2 Loss of a Central Office with Serving Wire Center Functions

The loss of a Central Office that also serves as a Serving Wire Center (SWC) will be restored as described in section 5.2.1.

5.2.3 Loss of a Central Office with Tandem Functions

When BellSouth loses a Central Office building that serves as an Access Tandem and as a SWC, the ECC will

- a) Place specialists and emergency equipment on notice;
- b) Inventory the damage to determine what equipment and/or functions are lost;
- c) Move containerized emergency equipment and facility equipment to the stricken area, if necessary;
- d) Begin reconnecting service for Hospitals, Police and other emergency agencies;
- e) Re-direct as much traffic as possible to the alternate access tandem (if available) for delivery to those CLECs utilizing a different location as a SWC;
- f) Begin aggregating traffic to a location near the damaged building. From this location, begin re-establishing trunk groups to the CLECs for the delivery of traffic normally found on the direct trunk groups. (This aggregation point may be the alternate access tandem location or another CO on a primary facility route.)
- g) Begin restoring service to CLECs and other customers.

5.2.4 Loss of a Facility Hub

In the event that BellSouth loses a facility hub, the recovery process is much the same as above. Once the NMC has observed the problem and administered the appropriate controls, the ECC will assume authority for the repairs. The recovery effort will include

- a) Placing specialists and emergency equipment on notice;
- b) Inventorying the damage to determine what equipment and/or functions are lost;
- c) Moving containerized emergency equipment to the stricken area, if necessary;
- d) Reconnecting service for Hospitals, Police and other emergency agencies; and
- e) Restoring service to CLECs and other customers. If necessary, BellSouth will aggregate the traffic at another location and build temporary facilities. This alternative would be viable for a location that is destroyed and building repairs are required.

5.3 COMBINED OUTAGE (CLEC AND BELLSOUTH EQUIPMENT)

In some instances, a disaster may impact BellSouth's equipment as well as the CLECs'. This situation will be handled in much the same way as described in section 5.2.3. Since BellSouth and the CLECs will be utilizing temporary equipment, close coordination will be required.

6.0 T1 IDENTIFICATION PROCEDURES

During the restoration of service after a disaster, BellSouth may be forced to aggregate traffic for delivery to a CLEC. During this process, T1 traffic may be consolidated onto DS3s and may become unidentifiable to the Carrier. Because resources will be limited, BellSouth may be forced to "package" this traffic entirely differently than normally received by the CLECs. Therefore, a method for identifying the T1 traffic on the DS3s and providing the information to the Carriers is required.

7.0 ACRONYMS

- CO - Central Office (BellSouth)
- DS3 - Facility that carries 28 T1s (672 circuits)
- ECC - Emergency Control Center (BellSouth)
- CLEC - Competitive Local Exchange Carrier
- NMC - Network Management Center
- SWC - Serving Wire Center (BellSouth switch)
- T1 - Facility that carries 24 circuits

Hurricane Information

During a hurricane, BellSouth will make every effort to keep CLECs updated on the status of our network. Information centers will be set up throughout BellSouth Telecommunications. These centers are not intended to be used for escalations, but rather to keep the CLEC informed of network related issues, area damages and dispatch conditions, etc.

Hurricane-related information can also be found on line at http://www.interconnection.bellsouth.com/network/disaster/dis_resp.htm. Information concerning Mechanized Disaster Reports can also be found at this website by clicking on CURRENT MDR REPORTS or by going directly to <http://www.interconnection.bellsouth.com/network/disaster/mdrs.htm>.

BST Disaster Management Plan

BellSouth maintenance centers have geographical and redundant communication capabilities. In the event of a disaster removing any maintenance center from service another geographical center would assume maintenance responsibilities. The contact numbers will not change and the transfer will be transparent to the CLEC.

**FIRST AMENDMENT TO
INTERCONNECTION AGREEMENT BETWEEN
BELLSOUTH TELECOMMUNICATIONS, INC.
AND LEVEL 3 COMMUNICATIONS, LLC
DATED JANUARY 1, 2001**

This Agreement (the "Amendment") is made and entered into between BellSouth Telecommunications, Inc. ("BellSouth") a Georgia corporation, and Level 3 Communications, LLC ("Level 3") a Delaware limited liability company.

WHEREAS, The Parties desire to amend that certain Interconnection Agreement between BellSouth and Level 3 dated January 1, 2001 (the "Interconnection Agreement") in order to include the Certification Identification Number for the state of Louisiana to the Agreement;

NOW THEREFORE, in consideration of the mutual provisions contained herein and other good and valuable consideration, the receipt and sufficiency of which are hereby acknowledged, BellSouth and Level 3 hereby covenant and agree as follows:

1. Section 25, Filing of Agreement, of General Terms and Conditions - Part A is being amended to include the following paragraph:

For electronic filing purposes in the State of Louisiana, the CLEC Louisiana Certification Number is required and must be provided by Level 3 prior to filing of the Agreement. The CLEC Louisiana Certification Number for Level 3 is TSP00282.

2. The Parties agree that all of the other provisions of the Interconnection Agreement, dated January 1, 2001, shall remain in full force and effect.

3. The Parties further agree that either or both of the Parties is authorized to submit this Amendment to the Louisiana Public Service Commission or other regulatory body having jurisdiction over the subject matter of this Amendment, for approval subject to Section 252(e) of the federal Telecommunications Act of 1996.

This Amendment is made effective upon the date that it is signed by both Parties.

IN WITNESS WHEREOF, the parties hereto have caused this Amendment to be executed by their respective duly authorized representatives on the data indicated below.

Signature on File
BellSouth Telecommunications, Inc.

By: Greg Follensbee

Title: Senior Director

Date: 5/24/01

Signature on File
Level 3 Communications, LLC

By: Kevin Paul

Title: VP Softswitch Deployment

Date: 5/22/01

249606

**AMENDMENT
TO THE
AGREEMENT BETWEEN
LEVEL 3 COMMUNICATIONS, LLC
AND
BELLSOUTH TELECOMMUNICATIONS, INC.
EFFECTIVE JANUARY 1, 2001**

Pursuant to this Amendment, (the "Amendment") Level 3 Communications, LLC ("Level 3") and BellSouth Telecommunications, Inc. ("BellSouth"), hereinafter referred to collectively as the "Parties", hereby agree to amend that certain Interconnection Agreement with an effective date of January 1, 2001 ("Agreement").

WHEREAS, BellSouth and Level 3 entered into the Agreement with an effective date January 1, 2001, and;

NOW THEREFORE, in consideration of the mutual provisions contained herein and other good and valuable consideration, the receipt and sufficiency of which are hereby acknowledged, the Parties hereby covenant and agree as follows:

1. Attachment 3, Exhibit A, Rates, is hereby deleted in its entirety and replaced with a new Attachment 3, Exhibit A, Rates, as set forth in Exhibit 1 attached hereto and incorporated herein by this reference.
2. All of the other provisions of the Agreement, effective January 1, 2001, shall remain in full force and effect.
3. Either or both of the Parties are authorized to submit this Amendment to the respective state regulatory authorities for approval subject to Section 252(e) of the Communications Act of 1934 as amended by the Federal Telecommunications Act of 1996.

IN WITNESS WHEREOF, the Parties hereto have caused this Amendment to be executed by their respective duly authorized representatives and shall be deemed effective thirty (30) calendar days following the date of the last signature of both Parties.

BellSouth Telecommunications, Inc.

Level 3 Communications, LLC

By: _____

By: _____

Name: Greg Follensbee

Name: _____

Title: Senior Director

Title: _____

Date: _____

Date: _____

LOCAL INTERCONNECTION - Alabama										Attachment: 3		Exhibit: A				
CATEGORY	NOTES	RATE ELEMENTS	Interim	Zone	BCS	USOC	RATES(\$)				Svc Order Submitted Elec per LSR	Svc Order Submitted Manually per LSR	Incremental Charge - Manual Svc Order vs. Electronic-1st	Incremental Charge - Manual Svc Order vs. Electronic-Add'l	Incremental Charge - Manual Svc Order vs. Electronic-Disc 1st	Incremental Charge - Manual Svc Order vs. Electronic-Disc Add'l
							Rec	Nonrecurring		Nonrecurring Disconnect						
							First	Add'l	First	Add'l	SOMEK	SOMAN	SOMAN	SOMAN	SOMAN	SOMAN
LOCAL INTERCONNECTION (CALL TRANSPORT AND TERMINATION)																
NOTE: "bk" beside a rate indicates that the Parties have agreed to bill and keep for that element under certain circumstances pursuant to the terms and conditions in Attachment 3.																
NOTE: The Parties will report a Percent Local Facility ("PLF") factor to one another to represent the percentage of switched dedicated facilities utilized for local traffic																
COMPENSATION																
		Single Rate for Local and ISP-bound Traffic (1/1/02 - 12/31/02)			OHD		.0015									
		Single Rate for Local and ISP-bound Traffic (1/1/03 - 12/31/03)			OHD		.001									
COMPENSATION FOR TRANSIT AND MTA TRAFFIC																
		Tandem Switching Function Per MOU			OHD		0.0005692									
		Multiple Tandem Switching, per MOU (applies to intial tandem only)			OHD		0.0005692									
		Tandem Intermediary Charge, per MOU*			OHD		0.0015									
* This charge is applicable only to transit traffic and is applied in addition to applicable switching and/or interconnection charges.																
TRUNK CHARGE																
		Installation Trunk Side Service - per DS0			OHD	TPP++		333.69bk	56.91bk							
		Dedicated End Office Trunk Port Service-per DS0**			OHD	TDE0P	0.00									
		Dedicated End Office Trunk Port Service-per DS1**			OH1	OH1MS	TDE1P	0.00								
		Dedicated Tandem Trunk Port Service-per DS0**			OHD	TDW0P	0.00									
		Dedicated Tandem Trunk Port Service-per DS1**			OH1	OH1MS	TDW1P	0.00								
** This rate element is recovered on a per MOU basis and is included in the End Office Switching and Tandem Switching, per MOU rate elements																
COMMON TRANSPORT (Shared)																
		Common Transport - Per Mile, Per MOU			OHD		0.0000026									
		Common Transport - Facilities Termination Per MOU			OHD		0.0003685									
LOCAL INTERCONNECTION (TRANSPORT)																
INTEROFFICE CHANNEL - DEDICATED TRANSPORT - VOICE GRADE																
		Interoffice Channel - Dedicated Transport - 2-Wire Voice Grade - Per Mile per month			OHL, OHM	1L5NF	0.0101bk									
		Interoffice Channel - Dedicated Transport- 2- Wire Voice Grade - Facility Termination per month			OHL, OHM	1L5NF	24.15bk	54.82bk					13.79bk			
INTEROFFICE CHANNEL - DEDICATED TRANSPORT - 56/64 KBPS																
		Interoffice Channel - Dedicated Transport - 56 kbps - per mile per month			OHL, OHM	1L5NK	0.0101bk									
		Interoffice Channel - Dedicated Transport - 56 kbps - Facility Termination per month			OHL, OHM	1L5NK	17.28bk	54.82bk					13.79bk			
		Interoffice Channel - Dedicated Transport - 64 kbps - per mile per month			OHL, OHM	1L5NK	0.0101bk									
		Interoffice Channel - Dedicated Transport - 64 kbps - Facility Termination per month			OHL, OHM	1L5NK	17.28bk	54.82bk					13.79bk			
INTEROFFICE CHANNEL - DEDICATED TRANSPORT - DS1																
		Interoffice Channel - Dedicated Channel - DS1 - Per Mile per month			OH1, OH1MS	1L5NL	0.2067bk									
		Interoffice Channel - Dedicated Tranport - DS1 - Facility Termination per month			OH1, OH1MS	1L5NL	68.75bk	163.61bk					28.88bk			
INTEROFFICE CHANNEL - DEDICATED TRANSPORT- DS3																
		Interoffice Channel - Dedicated Transport - DS3 - Per Mile per month			OH3, OH3MS	1L5NM	4.67bk									
		Interoffice Channel - Dedicated Transport - DS3 - Facility Termination per month			OH3, OH3MS	1L5NM	804.02bk	325.51bk					116.91bk			
LOCAL CHANNEL - DEDICATED TRANSPORT																
		Local Channel - Dedicated - 2-Wire Voice Grade per month			OHL, OHM	TEFV2	15.96bk	386.19bk	66.33bk	73.28bk		6.39bk				
		Local Channel - Dedicated - 4-Wire Voice Grade per month			OHL, OHM	TEFV4	17.06bk	387.06bk	67.20bk	74.22bk		7.33bk				
		Local Channel - Dedicated - DS1 per month			OH1	TEFHG	41.52bk	354.94bk	307.43bk	44.38bk		30.52bk				
		Local Channel - Dedicated - DS3 Facility Termination per month			OH3	TEFHJ	476.04bk	903.03bk	527.87bk	238.97bk		167.16bk				
LOCAL INTERCONNECTION MID-SPAN MEET																
NOTE: If Access service ride Mid-Span Meet, one-half the tariffed service Local Channel rate is applicable.																
		Local Channel - Dedicated - DS1 per month			OH1MS	TEFHG	0.00	0.00								
		Local Channel - Dedicated - DS3 per month			OH3MS	TEFHJ	0.00	0.00								
MULTIPLEXERS																

LOCAL INTERCONNECTION - Alabama										Attachment: 3		Exhibit: A				
CATEGORY	NOTES	RATE ELEMENTS	Interim	Zone	BCS	USOC	RATES(\$)				Svc Order Submitted Elec per LSR	Svc Order Submitted Manually per LSR	Incremental Charge - Manual Svc Order vs. Electronic-1st	Incremental Charge - Manual Svc Order vs. Electronic-Add'l	Incremental Charge - Manual Svc Order vs. Electronic-Disc 1st	Incremental Charge - Manual Svc Order vs. Electronic-Disc Add'l
							Rec	Nonrecurring		Nonrecurring Disconnect						
							First	Add'l	First	Add'l	SOMEK	SOMAN	SOMAN	SOMAN	SOMAN	SOMAN
		Channelization - DS1 to DS0 Channel System			OH1, OH1MS	SATN1	122.50bk	182.08bk	125.14bk	21.07bk	19.58bk					
		DS3 to DS1 Channel System per month			OH3, OH3MS	SATNS	201.37bk	356.28bk	187.94bk	66.51bk	63.65bk					
		DS3 Interface Unit (DS1 COC) per month			OH1, OH1MS	SATCO	15.39bk	13.15bk	9.43bk							
Notes: If no rate is identified in the contract, the rates, terms, and conditions for the specific service or function will be as set forth in applicable BellSouth tariff.																

LOCAL INTERCONNECTION - Florida										Attachment: 3		Exhibit: A				
CATEGORY	NOTES	RATE ELEMENTS	Interim	Zone	BCS	USOC	RATES(\$)				Svc Order Submitted Elec per LSR	Svc Order Submitted Manually per LSR	Incremental Charge - Manual Svc Order vs. Electronic-1st	Incremental Charge - Manual Svc Order vs. Electronic-Add'l	Incremental Charge - Manual Svc Order vs. Electronic-Disc 1st	Incremental Charge - Manual Svc Order vs. Electronic-Disc Add'l
							Rec	Nonrecurring		Nonrecurring Disconnect						
							First	Add'l	First	Add'l	SOMEc	SOMAN	SOMAN	SOMAN	SOMAN	SOMAN
LOCAL INTERCONNECTION (CALL TRANSPORT AND TERMINATION)																
NOTE: "bk" beside a rate indicates that the Parties have agreed to bill and keep for that element under certain circumstances pursuant to the terms and conditions in Attachment 3.																
NOTE: The Parties will report a Percent Local Facility ("PLF") factor to one another to represent the percentage of switched dedicated facilities utilized for local traffic.																
COMPENSATION																
		Single Rate for Local and ISP-bound Traffic (1/1/02 - 12/31/02)			OHD		.0015									
		Single Rate for Local and ISP-bound Traffic (1/1/03 - 12/31/03)			OHD		.001									
COMPENSATION FOR TRANSIT AND MTA TRAFFIC																
		Tandem Switching Function Per MOU			OHD		0.0006019									
		Multiple Tandem Switching, per MOU (applies to initial tandem only)			OHD		0.0006019									
TRUNK CHARGE																
		Installation Trunk Side Service - per DS0			OHD	TPP++		336.43bk	57.38bk							
		Dedicated End Office Trunk Port Service-per DS0**			OHD	TDE0P	0.00									
		Dedicated End Office Trunk Port Service-per DS1**			OH1	OH1MS	TDE1P	0.00								
		Dedicated Tandem Trunk Port Service-per DS0**			OHD		TDW0P	0.00								
		Dedicated Tandem Trunk Port Service-per DS1**			OH1	OH1MS	TDW1P	0.00								
** This rate element is recovered on a per MOU basis and is included in the End Office Switching and Tandem Switching, per MOU rate elements																
COMMON TRANSPORT (Shared)																
		Common Transport - Per Mile, Per MOU			OHD		0.0000035									
		Common Transport - Facilities Termination Per MOU			OHD		0.0004372									
LOCAL INTERCONNECTION (TRANSPORT)																
INTEROFFICE CHANNEL - DEDICATED TRANSPORT - VOICE GRADE																
		Interoffice Channel - Dedicated Transport - 2-Wire Voice Grade - Per Mile per month			OHL, OHM	1L5NF	0.0091bk									
		Interoffice Channel - Dedicated Transport - 2-Wire Voice Grade - Facility Termination per month			OHL, OHM	1L5NF	25.32bk	31.78bk	7.03bk							
INTEROFFICE CHANNEL - DEDICATED TRANSPORT - 56/64 KBPS																
		Interoffice Channel - Dedicated Transport - 56 kbps - per mile per month			OHL, OHM	1L5NK	0.0091bk									
		Interoffice Channel - Dedicated Transport - 56 kbps - Facility Termination per month			OHL, OHM	1L5NK	18.44bk	31.78bk	7.03bk							
		Interoffice Channel - Dedicated Transport - 64 kbps - per mile per month			OHL, OHM	1L5NK	0.0091bk									
		Interoffice Channel - Dedicated Transport - 64 kbps - Facility Termination per month			OHL, OHM	1L5NK	18.44bk	31.78bk	7.03bk							
INTEROFFICE CHANNEL - DEDICATED TRANSPORT - DS1																
		Interoffice Channel - Dedicated Channel - DS1 - Per Mile per month			OH1, OH1MS	1L5NL	0.1856bk									
		Interoffice Channel - Dedicated Transport - DS1 - Facility Termination per month			OH1, OH1MS	1L5NL	88.44bk	98.47bk	19.05bk							
INTEROFFICE CHANNEL - DEDICATED TRANSPORT - DS3																
		Interoffice Channel - Dedicated Transport - DS3 - Per Mile per month			OH3, OH3MS	1L5NM	3.87bk									
		Interoffice Channel - Dedicated Transport - DS3 - Facility Termination per month			OH3, OH3MS	1L5NM	1071.00bk	219.28bk	70.56bk							
LOCAL CHANNEL - DEDICATED TRANSPORT																
		Local Channel - Dedicated - 2-Wire Voice Grade per month			OHL, OHM	TEFV2	21.94bk	265.84bk	46.97bk	37.63bk	4.00bk					
		Local Channel - Dedicated - 4-Wire Voice Grade per month			OHL, OHM	TEFV4	22.81bk	266.54bk	47.67bk	44.22bk	5.33bk					
		Local Channel - Dedicated - DS1 per month			OH1	TEFHG	35.28bk	216.65bk	183.54bk	24.30bk	16.95bk					
		Local Channel - Dedicated - DS3 Facility Termination per month			OH3	TEFHJ	531.91bk	556.37bk	343.01bk	139.13bk	96.84bk					
LOCAL INTERCONNECTION MID-SPAN MEET																
NOTE: If Access service ride Mid-Span Meet, one-half the tariffed service Local Channel rate is applicable.																
		Local Channel - Dedicated - DS1 per month			OH1MS	TEFHG	0.00	0.00								
		Local Channel - Dedicated - DS3 per month			OH3MS	TEFHJ	0.00	0.00								
MULTIPLXERS																
		Channelization - DS1 to DS0 Channel System			OH1, OH1MS	SATN1	146.77bk	101.42bk	71.62bk	11.09bk	10.49bk					
		DS3 to DS1 Channel System per month			OH3, OH3MS	SATNS	211.19bk	199.28bk	118.64bk	40.34bk	39.07bk					
		DS3 Interface Unit (DS1 COCI) per month			OH1, OH1MS	SATCO	13.76bk	10.07bk	7.08bk							
Notes: If no rate is identified in the contract, the rates, terms, and conditions for the specific service or function will be as set forth in applicable BellSouth tariff.																

LOCAL INTERCONNECTION - Georgia										Attachment: 3		Exhibit: A				
CATEGORY	NOTES	RATE ELEMENTS	Interim	Zone	BCS	USOC	RATES(\$)				Svc Order Submitted Elec per LSR	Svc Order Submitted Manually per LSR	Incremental Charge - Manual Svc Order vs. Electronic-1st	Incremental Charge - Manual Svc Order vs. Electronic-Add'l	Incremental Charge - Manual Svc Order vs. Electronic-Disc 1st	Incremental Charge - Manual Svc Order vs. Electronic-Disc Add'l
							Rec	Nonrecurring		Nonrecurring Disconnect						
							First	Add'l	First	Add'l	SOMEK	SOMAN	SOMAN	SOMAN	SOMAN	SOMAN
LOCAL INTERCONNECTION (CALL TRANSPORT AND TERMINATION)																
NOTE: "bk" beside a rate indicates that the Parties have agreed to bill and keep for that element under certain circumstances pursuant to the terms and conditions in Attachment 3.																
NOTE: The Parties will report a Percent Local Facility ("PLF") factor to one another to represent the percentage of switched dedicated facilities utilized for local traffic.																
COMPENSATION																
		Single Rate for Local and ISP-bound Traffic (1/1/02 - 12/31/02)			OHD					.0015						
		Single Rate for Local and ISP-bound Traffic (1/1/03 - 12/31/03)			OHD					.001						
COMPENSATION FOR TRANSIT AND MTA TRAFFIC																
		Tandem Switching Function Per MOU			OHD					0.0011009						
		Multiple Tandem Switching, per MOU (applies to intial tandem only)			OHD					0.0011009						
TRUNK CHARGE																
		Installation Trunk Side Service - per DS0			OHD	TPP++				333.28bk	56.84bk					
		Dedicated End Office Trunk Port Service-per DS0**			OHD	TDE0P				0.00						
		Dedicated End Office Trunk Port Service-per DS1**			OH1 OH1MS	TDE1P				0.00						
		Dedicated Tandem Trunk Port Service-per DS0**			OHD	TDW0P				0.00						
		Dedicated Tandem Trunk Port Service-per DS1**			OH1 OH1MS	TDW1P				0.00						
** This rate element is recovered on a per MOU basis and is included in the End Office Switching and Tandem Switching, per MOU rate elements																
COMMON TRANSPORT (Shared)																
		Common Transport - Per Mile, Per MOU			OHD					0.000008						
		Common Transport - Facilities Termination Per MOU			OHD					0.0004152						
LOCAL INTERCONNECTION (TRANSPORT)																
INTEROFFICE CHANNEL - DEDICATED TRANSPORT - VOICE GRADE																
		Interoffice Channel - Dedicated Transport - 2-Wire Voice Grade - Per Mile per month			OHL, OHM	1L5NF				0.0222bk						
		Interoffice Channel - Dedicated Transport - 2- Wire Voice Grade - Facility Termination per month			OHL, OHM	1L5NF				17.07bk	36.08bk					
INTEROFFICE CHANNEL - DEDICATED TRANSPORT - 56/64 KBPS																
		Interoffice Channel - Dedicated Transport - 56 kbps - per mile per month			OHL, OHM	1L5NK				0.0222bk						
		Interoffice Channel - Dedicated Transport - 56 kbps - Facility Termination per month			OHL, OHM	1L5NK				16.45bk	36.08bk					
		Interoffice Channel - Dedicated Transport - 64 kbps - per mile per month			OHL, OHM	1L5NK				0.0222bk						
		Interoffice Channel - Dedicated Transport - 64 kbps - Facility Termination per month			OHL, OHM	1L5NK				16.45bk	36.08bk					
INTEROFFICE CHANNEL - DEDICATED TRANSPORT - DS1																
		Interoffice Channel - Dedicated Channel - DS1 - Per Mile per month			OH1, OH1MS	1L5NL				0.4523bk						
		Interoffice Channel - Dedicated Tranport - DS1 - Facility Termination per month			OH1, OH1MS	1L5NL				78.47bk	111.75bk					
INTEROFFICE CHANNEL - DEDICATED TRANSPORT- DS3																
		Interoffice Channel - Dedicated Transport - DS3 - Per Mile per month			OH3, OH3MS	1L5NM				2.72bk						
		Interoffice Channel - Dedicated Transport - DS3 - Facility Termination per month			OH3, OH3MS	1L5NM				788.00bk	330.77bk					
LOCAL CHANNEL - DEDICATED TRANSPORT																
		Local Channel - Dedicated - 2-Wire Voice Grade per month			OHL, OHM	TEFV2				13.91bk	382.95bk	62.40bk				
		Local Channel - Dedicated - 4-Wire Voice Grade per month			OHL, OHM	TEFV4				14.99bk	368.44bk	64.05bk				
		Local Channel - Dedicated - DS1 per month			OH1	TEFHG				38.36bk	356.15bk	312.89bk				
		Local Channel - Dedicated - DS3 Facility Termination per month			OH3	TEFHJ				515.91bk	639.50bk	426.31bk				
LOCAL INTERCONNECTION MID-SPAN MEET																
NOTE: If Access service ride Mid-Span Meet, one-half the tariffed service Local Channel rate is applicable.																
		Local Channel - Dedicated - DS1 per month			OH1MS	TEFHG				0.00	0.00					
		Local Channel - Dedicated - DS3 per month			OH3MS	TEFHJ				0.00	0.00					
MULTIPLEXERS																
		Channelization - DS1 to DS0 Channel System			OH1, OH1MS	SATN1				126.22bk	198.22bk	123.59bk				
		DS3 to DS1 Channel System per month			OH3, OH3MS	SATNS				182.04bk	280.66bk	195.33bk				

LOCAL INTERCONNECTION - Georgia										Attachment: 3				Exhibit: A			
CATEGORY	NOTES	RATE ELEMENTS	Interim	Zone	BCS	USOC	RATES(\$)				Svc Order Submitted Elec per LSR	Svc Order Submitted Manually per LSR	Incremental Charge - Manual Svc Order vs. Electronic-1st	Incremental Charge - Manual Svc Order vs. Electronic-Add'l	Incremental Charge - Manual Svc Order vs. Electronic-Disc 1st	Incremental Charge - Manual Svc Order vs. Electronic-Disc Add'l	
							Rec	Nonrecurring		Nonrecurring Disconnect							OSS RATES (\$)
							First	Add'l	First	Add'l	SOMEK	SOMAN	SOMAN	SOMAN	SOMAN	SOMAN	
		DS3 Interface Unit (DS1 COCI) per month			OH1, OH1MS	SATCO	11.02bk	12.02bk	8.66bk								
Notes: If no rate is identified in the contract, the rates, terms, and conditions for the specific service or function will be as set forth in applicable BellSouth tariff.																	

LOCAL INTERCONNECTION - Kentucky										Attachment: 3		Exhibit: A				
CATEGORY	NOTES	RATE ELEMENTS	Interim	Zone	BCS	USOC	RATES(\$)				Svc Order Submitted Elec per LSR	Svc Order Submitted Manually per LSR	Incremental Charge - Manual Svc Order vs. Electronic-1st	Incremental Charge - Manual Svc Order vs. Electronic-Add'l	Incremental Charge - Manual Svc Order vs. Electronic-Disc 1st	Incremental Charge - Manual Svc Order vs. Electronic-Disc Add'l
							Rec	Nonrecurring		Nonrecurring Disconnect						
							First	Add'l	First	Add'l	SOMEC	SOMAN	SOMAN	SOMAN	SOMAN	SOMAN
LOCAL INTERCONNECTION (CALL TRANSPORT AND TERMINATION)																
NOTE: "bk" beside a rate indicates that the Parties have agreed to bill and keep for that element under certain circumstances pursuant to the terms and conditions in Attachment 3.																
NOTE: The Parties will report a Percent Local Facility ("PLF") factor to one another to represent the percentage of switched dedicated facilities utilized for local traffic.																
		Single Rate for Local and ISP-bound Traffic (1/1/02 - 12/31/02)			OHD		.0015									
		Single Rate for Local and ISP-bound Traffic (1/1/03 - 12/31/03)			OHD		.001									
COMPENSATION FOR TRANSIT AND MTA TRAFFIC																
		Tandem Switching Function Per MOU			OHD		0.0006772									
		Multiple Tandem Switching, per MOU (applies to initial tandem only)			OHD		0.0006772									
		Tandem Intermediary Charge, per MOU*			OHD		0.001096									
* This charge is applicable only to transit traffic and is applied in addition to applicable switching and/or interconnection charges.																
TRUNK CHARGE																
		Installation Trunk Side Service - per DS0			OHD	TPP++		334.09bk	57.12bk							
		Dedicated End Office Trunk Port Service-per DS0**			OHD	TDE0P	0.00									
		Dedicated End Office Trunk Port Service-per DS1**			OH1 OH1MS	TDE1P	0.00									
		Dedicated Tandem Trunk Port Service-per DS0**			OHD	TDW0P	0.00									
		Dedicated Tandem Trunk Port Service-per DS1**			OH1 OH1MS	TDW1P	0.00									
** This rate element is recovered on a per MOU basis and is included in the End Office Switching and Tandem Switching, per MOU rate elements																
COMMON TRANSPORT (Shared)																
		Common Transport - Per Mile, Per MOU			OHD		0.000003									
		Common Transport - Facilities Termination Per MOU			OHD		0.0007466									
LOCAL INTERCONNECTION (TRANSPORT)																
INTEROFFICE CHANNEL - DEDICATED TRANSPORT - VOICE GRADE																
		Interoffice Channel - Dedicated Transport - 2-Wire Voice Grade - Per Mile per month			OHL, OHM	1L5NF	0.01bk									
		Interoffice Channel - Dedicated Transport - 2- Wire Voice Grade - Facility Termination per month			OHL, OHM	1L5NF	29.11bk	47.34bk		22.77bk						
INTEROFFICE CHANNEL - DEDICATED TRANSPORT - 56/64 KBPS																
		Interoffice Channel - Dedicated Transport - 56 kbps - per mile per month			OHL, OHM	1L5NK	0.0115bk									
		Interoffice Channel - Dedicated Transport - 56 kbps - Facility Termination per month			OHL, OHM	1L5NK	20.97bk	47.35bk		22.77bk						
		Interoffice Channel - Dedicated Transport - 64 kbps - per mile per month			OHL, OHM	1L5NK	0.0115bk									
		Interoffice Channel - Dedicated Transport - 64 kbps - Facility Termination per month			OHL, OHM	1L5NK	20.97bk	47.35bk		22.77bk						
INTEROFFICE CHANNEL - DEDICATED TRANSPORT - DS1																
		Interoffice Channel - Dedicated Channel - DS1 - Per Mile per month			OH1, OH1MS	1L5NL	0.23bk									
		Interoffice Channel - Dedicated Transport - DS1 - Facility Termination per month			OH1, OH1MS	1L5NL	96.04bk	105.52bk		23.09bk						
INTEROFFICE CHANNEL - DEDICATED TRANSPORT - DS3																
		Interoffice Channel - Dedicated Transport - DS3 - Per Mile per month			OH3, OH3MS	1L5NM	4.97bk									
		Interoffice Channel - Dedicated Transport - DS3 - Facility Termination per month			OH3, OH3MS	1L5NM	1175.15bk	335.40bk		89.57bk						
LOCAL CHANNEL - DEDICATED TRANSPORT																
		Local Channel - Dedicated - 2-Wire Voice Grade per month			OHL, OHM	TEFV2	18.57bk	265.78bk	46.96bk	46.79bk	4.98bk					
		Local Channel - Dedicated - 4-Wire Voice Grade per month			OHL, OHM	TEFV4	19.86bk	266.48bk	47.65bk	47.54bk	5.73bk					
		Local Channel - Dedicated - DS1 per month			OH1	TEFHG	40.46bk	209.60bk	176.51bk	30.21bk	21.07bk					
		Local Channel - Dedicated - DS3 Facility Termination per month			OH3	TEFHJ	576.05bk	551.38bk	338.08bk	173.00bk	120.42bk					
LOCAL INTERCONNECTION MID-SPAN MEET																
NOTE: If Access service ride Mid-Span Meet, one-half the tariffed service Local Channel rate is applicable.																
		Local Channel - Dedicated - DS1 per month			OH1MS	TEFHG	0.00	0.00								
		Local Channel - Dedicated - DS3 per month			OH3MS	TEFHJ	0.00	0.00								
MULTIPLEXERS																
		Channelization - DS1 to DS0 Channel System			OH1, OH1MS	SATN1	113.33bk	101.40bk	71.60bk	13.79bk	13.04bk					
		DS3 to DS1 Channel System per month			OH3, OH3MS	SATNS	158.20bk	199.23bk	118.62bk	50.16bk	48.59bk					
		DS3 Interface Unit (DS1 COCI) per month			OH1, OH1MS	SATCO	11.80bk	10.07bk	7.08bk							
Notes: If no rate is identified in the contract, the rates, terms, and conditions for the specific service or function will be as set forth in applicable BellSouth tariff.																

LOCAL INTERCONNECTION - Louisiana										Attachment: 3				Exhibit: A		
CATEGORY	NOTES	RATE ELEMENTS	Interim	Zone	BCS	USOC	RATES(\$)				Svc Order Submitted Elec per LSR	Svc Order Submitted Manually per LSR	Incremental Charge - Manual Svc Order vs. Electronic-1st	Incremental Charge - Manual Svc Order vs. Electronic-Add'l	Incremental Charge - Manual Svc Order vs. Electronic-Disc 1st	Incremental Charge - Manual Svc Order vs. Electronic-Disc Add'l
							Rec	Nonrecurring		Nonrecurring Disconnect						
							First	Add'l	First	Add'l	SOMEK	SOMAN	SOMAN	SOMAN	SOMAN	SOMAN
LOCAL INTERCONNECTION (CALL TRANSPORT AND TERMINATION)																
NOTE: "bk" beside a rate indicates that the Parties have agreed to bill and keep for that element under certain circumstances pursuant to the terms and conditions in Attachment 3.																
NOTE: The Parties will report a Percent Local Facility ("PLF") factor to one another to represent the percentage of switched dedicated facilities utilized for local traffic.																
		Single Rate for Local and ISP-bound Traffic (1/1/02 - 12/31/02)			OHD			.0015								
		Single Rate for Local and ISP-bound Traffic (1/1/03 - 12/31/03)			OHD			.001								
TANDEM SWITCHING																
		Tandem Switching Function Per MOU			OHD			0.0005507								
		Multiple Tandem Switching, per MOU (applies to intial tandem only)			OHD			0.0005507								
TRUNK CHARGE																
		Installation Trunk Side Service - per DS0			OHD	TPP++			334.94bk	56.98bk						
		Dedicated End Office Trunk Port Service-per DS0**			OHD	TDE0P		0.00								
		Dedicated End Office Trunk Port Service-per DS1**			OH1 OH1MS	TDE1P		0.00								
		Dedicated Tandem Trunk Port Service-per DS0**			OHD	TDW0P		0.00								
		Dedicated Tandem Trunk Port Service-per DS1**			OH1 OH1MS	TDW1P		0.00								
** This rate element is recovered on a per MOU basis and is included in the End Office Switching and Tandem Switching, per MOU rate elements																
COMMON TRANSPORT (Shared)																
		Common Transport - Per Mile, Per MOU			OHD			0.0000032								
		Common Transport - Facilities Termination Per MOU			OHD			0.0003748								
LOCAL INTERCONNECTION (TRANSPORT)																
INTEROFFICE CHANNEL - DEDICATED TRANSPORT - VOICE GRADE																
		Interoffice Channel - Dedicated Transport - 2-Wire Voice Grade - Per Mile per month			OHL, OHM	1L5NF		0.013bk								
		Interoffice Channel - Dedicated Transport- 2- Wire Voice Grade - Facility Termination per month			OHL, OHM	1L5NF		22.60bk	26.62bk							
INTEROFFICE CHANNEL - DEDICATED TRANSPORT - 56/64 KBPS																
		Interoffice Channel - Dedicated Transport - 56 kbps - per mile per month			OHL, OHM	1L5NK		0.013bk								
		Interoffice Channel - Dedicated Transport - 56 kbps - Facility Termination per month			OHL, OHM	1L5NK		15.61bk	26.62bk							
		Interoffice Channel - Dedicated Transport - 64 kbps - per mile per month			OHL, OHM	1L5NK		0.013bk								
		Interoffice Channel - Dedicated Transport - 64 kbps - Facility Termination per month			OHL, OHM	1L5NK		15.61bk	26.62bk							
INTEROFFICE CHANNEL - DEDICATED TRANSPORT - DS1																
		Interoffice Channel - Dedicated Channel - DS1 - Per Mile per month			OH1, OH1MS	1L5NL		0.2652bk								
		Interoffice Channel - Dedicated Tranport - DS1 - Facility Termination per month			OH1, OH1MS	1L5NL		70.47bk	79.44bk							
INTEROFFICE CHANNEL - DEDICATED TRANSPORT- DS3																
		Interoffice Channel - Dedicated Transport - DS3 - Facility Termination per month			OH3, OH3MS	1L5NM		6.04bk								
		Interoffice Channel - Dedicated Transport - DS3 - Facility Termination per month			OH3, OH3MS	1L5NM		850.45bk	158.05bk							
LOCAL CHANNEL - DEDICATED TRANSPORT																
		Local Channel - Dedicated - 2-Wire Voice Grade per month			OHL, OHM	TEFV2		18.32bk	187.51bk	32.21bk						
		Local Channel - Dedicated - 4-Wire Voice Grade per month			OHL, OHM	TEFV4		19.41bk	187.94bk	32.63bk						
		Local Channel - Dedicated - DS1 per month			OH1	TEFHG		39.18bk	172.34bk	149.27bk						
		Local Channel - Dedicated - DS3 Facility Termination per month			OH3	TEFHJ		469.44bk	438.46bk	256.30bk						
LOCAL INTERCONNECTION MID-SPAN MEET																
NOTE: If Access service ride Mid-Span Meet, one-half the tariffed service Local Channel rate is applicable.																
		Local Channel - Dedicated - DS1 per month			OH1MS	TEFHG		0.00	0.00							
		Local Channel - Dedicated - DS3 per month			OH3MS	TEFHJ		0.00	0.00							
MULTIPLEXERS																
		Channelization - DS1 to DS0 Channel System			OH1, OH1MS	SATN1		105.09bk	88.41bk	60.76bk						
		DS3 to DS1 Channel System per month			OH3, OH3MS	SATNS		201.48bk	172.99bk	91.25bk						

LOCAL INTERCONNECTION - Louisiana										Attachment: 3				Exhibit: A			
CATEGORY	NOTES	RATE ELEMENTS	Interim	Zone	BCS	USOC	RATES(\$)				Svc Order Submitted Elec per LSR	Svc Order Submitted Manually per LSR	Incremental Charge - Manual Svc Order vs. Electronic-1st	Incremental Charge - Manual Svc Order vs. Electronic-Add'l	Incremental Charge - Manual Svc Order vs. Electronic-Disc 1st	Incremental Charge - Manual Svc Order vs. Electronic-Disc Add'l	
							Rec	Nonrecurring		Nonrecurring Disconnect							OSS RATES (\$)
							First	Add'l	First	Add'l	SOME C	SOMAN	SOMAN	SOMAN	SOMAN	SOMAN	
		DS3 Interface Unit (DS1 COCI) per month			OH1, OH1MS	SATCO	11.78bk	6.39bk	4.58bk								
Notes: If no rate is identified in the contract, the rates, terms, and conditions for the specific service or function will be as set forth in applicable BellSouth tariff.																	

LOCAL INTERCONNECTION - Mississippi										Attachment: 3		Exhibit: A				
CATEGORY	NOTES	RATE ELEMENTS	Interim	Zone	BCS	USOC	RATES(\$)				Svc Order Submitted Elec per LSR	Svc Order Submitted Manually per LSR	Incremental Charge - Manual Svc Order vs. 1st	Incremental Charge - Manual Svc Order vs. Electronic-Add'l	Incremental Charge - Manual Svc Order vs. Electronic-Disc 1st	Incremental Charge - Manual Svc Order vs. Electronic-Disc Add'l
							Rec	Nonrecurring		Nonrecurring Disconnect						
							First	Add'l	First	Add'l	SOMEK	SOMAN	SOMAN	SOMAN	SOMAN	SOMAN
LOCAL INTERCONNECTION (CALL TRANSPORT AND TERMINATION)																
NOTE: "bk" beside a rate indicates that the Parties have agreed to bill and keep for that element under certain circumstances pursuant to the terms and conditions in Attachment 3.																
NOTE: The Parties will report a Percent Local Facility ("PLF") factor to one another to represent the percentage of switched dedicated facilities utilized for local traffic.																
COMPENSATION																
		Single Rate for Local and ISP-bound Traffic (1/1/02 - 12/31/02)			OHD		.0015									
		Single Rate for Local and ISP-bound Traffic (1/1/03 - 12/31/03)			OHD		.001									
COMPENSATION FOR TRANSIT AND MTA TRAFFIC																
		Tandem Switching Function Per MOU			OHD		0.0005379									
		Multiple Tandem Switching, per MOU (applies to intial tandem only)			OHD		0.0005379									
TRUNK CHARGE																
		Installation Trunk Side Service - per DS0			OHD	TPP++		334.11bk	56.98bk							
		Dedicated End Office Trunk Port Service-per DS0**			OHD	TDE0P	0.00									
		Dedicated End Office Trunk Port Service-per DS1**			OH1	OH1MS	TDE1P	0.00								
		Dedicated Tandem Trunk Port Service-per DS0**			OHD	TDW0P	0.00									
		Dedicated Tandem Trunk Port Service-per DS1**			OH1	OH1MS	TDW1P	0.00								
** This rate element is recovered on a per MOU basis and is included in the End Office Switching and Tandem Switching, per MOU rate elements																
COMMON TRANSPORT (Shared)																
		Common Transport - Per Mile, Per MOU			OHD		0.0000026									
		Common Transport - Facilities Termination Per MOU			OHD		0.0004541									
LOCAL INTERCONNECTION (TRANSPORT)																
INTEROFFICE CHANNEL - DEDICATED TRANSPORT - VOICE GRADE																
		Interoffice Channel - Dedicated Transport - 2-Wire Voice Grade - Per Mile per month			OHL, OHM	1L5NF	0.0098bk									
		Interoffice Channel - Dedicated Transport- 2- Wire Voice Grade - Facility Termination per month			OHL, OHM	1L5NF	22.52bk	27.57bk				7.11bk				
INTEROFFICE CHANNEL - DEDICATED TRANSPORT - 56/64 KBPS																
		Interoffice Channel - Dedicated Transport - 56 kbps - per mile per month			OHL, OHM	1L5NK	0.0098bk									
		Interoffice Channel - Dedicated Transport - 56 kbps - Facility Termination per month			OHL, OHM	1L5NK	15.68bk	27.57bk				7.11bk				
		Interoffice Channel - Dedicated Transport - 64 kbps - per mile per month			OHL, OHM	1L5NK	0.0098bk									
		Interoffice Channel - Dedicated Transport - 64 kbps - Facility Termination per month			OHL, OHM	1L5NK	15.68bk	27.57bk				7.11bk				
INTEROFFICE CHANNEL - DEDICATED TRANSPORT - DS1																
		Interoffice Channel - Dedicated Channel - DS1 - Per Mile per month			OH1, OH1MS	1L5NL	0.201bk									
		Interoffice Channel - Dedicated Tranport - DS1 - Facility Termination per month			OH1, OH1MS	1L5NL	57.33bk	82.28bk				14.90bk				
INTEROFFICE CHANNEL - DEDICATED TRANSPORT- DS3																
		Interoffice Channel - Dedicated Transport - DS3 - Per Mile per month			OH3, OH3MS	1L5NM	4.76bk									
		Interoffice Channel - Dedicated Transport - DS3 - Facility Termination per month			OH3, OH3MS	1L5NM	641.90bk	163.70bk				60.29bk				
LOCAL CHANNEL - DEDICATED TRANSPORT																
		Local Channel - Dedicated - 2-Wire Voice Grade per month			OHL, OHM	TEFV2	14.91bk	194.22bk	33.36bk	37.79bk		3.30bk				
		Local Channel - Dedicated - 4-Wire Voice Grade per month			OHL, OHM	TEFV4	15.99bk	194.66bk	33.80bk	38.27bk		3.78bk				
		Local Channel - Dedicated - DS1 per month			OH1	TEFHG	36.83bk	178.50bk	154.61bk	22.89bk		15.74bk				
		Local Channel - Dedicated - DS3 Facility Termination per month			OH3	TEFHJ	413.87bk	454.13bk	264.47bk	123.23bk		86.19bk				
LOCAL INTERCONNECTION MID-SPAN MEET																
NOTE: If Access service ride Mid-Span Meet, one-half the tariffed service Local Channel rate is applicable.																
		Local Channel - Dedicated - DS1 per month			OH1MS	TEFHG	0.00	0.00								
		Local Channel - Dedicated - DS3 per month			OH3MS	TEFHJ	0.00	0.00								
MULTIPLEXERS																
		Channelization - DS1 to DS0 Channel System			OH1, OH1MS	SATN1	102.85bk	91.57bk	62.94bk	10.87bk		10.10bk				
		DS3 to DS1 Channel System per month			OH3, OH3MS	SATNS	170.63bk	179.17bk	94.52bk	34.30bk		32.82bk				

LOCAL INTERCONNECTION - Mississippi										Attachment: 3				Exhibit: A		
CATEGORY	NOTES	RATE ELEMENTS	Interim	Zone	BCS	USOC	RATES(\$)				Svc Order Submitted Elec per LSR	Svc Order Submitted Manually per LSR	Incremental Charge - Manual Svc Order vs. Electronic-1st	Incremental Charge - Manual Svc Order vs. Electronic-Add'l	Incremental Charge - Manual Svc Order vs. Electronic-Disc 1st	Incremental Charge - Manual Svc Order vs. Electronic-Disc Add'l
							Rec	Nonrecurring		Nonrecurring Disconnect						
							First	Add'l	First	Add'l	SOMEK	SOMAN	SOMAN	SOMAN	SOMAN	SOMAN
		DS3 Interface Unit (DS1 COCI) per month			OH1, OH1MS	SATCO	12.96bk	6.62bk	4.74bk							
Notes: If no rate is identified in the contract, the rates, terms, and conditions for the specific service or function will be as set forth in applicable BellSouth tariff.																

LOCAL INTERCONNECTION - North Carolina										Attachment: 3		Exhibit: A				
CATEGORY	NOTES	RATE ELEMENTS	Interim	Zone	BCS	USOC	RATES(\$)				Svc Order Submitted Elec per LSR	Svc Order Submitted Manually per LSR	Incremental Charge - Manual Svc Order vs. Electronic-1st	Incremental Charge - Manual Svc Order vs. Electronic-Add'l	Incremental Charge - Manual Svc Order vs. Electronic-Disc 1st	Incremental Charge - Manual Svc Order vs. Electronic-Disc Add'l
							Rec	Nonrecurring		Nonrecurring Disconnect						
							First	Add'l	First	Add'l	SOMEK	SOMAN	SOMAN	SOMAN	SOMAN	SOMAN
LOCAL INTERCONNECTION (CALL TRANSPORT AND TERMINATION)																
NOTE: "bk" beside a rate indicates that the Parties have agreed to bill and keep for that element under certain circumstances pursuant to the terms and conditions in Attachment 3.																
NOTE: The Parties will report a Percent Local Facility ("PLF") factor to one another to represent the percentage of switched dedicated facilities utilized for local traffic.																
COMPENSATION																
		Single Rate for Local and ISP-bound Traffic (1/1/02 - 12/31/02)			OHD			.0015								
		Single Rate for Local and ISP-bound Traffic (1/1/03 - 12/31/03)			OHD			.001								
COMPENSATION FOR TRANSIT AND MTA TRAFFIC																
		Tandem Switching Function Per MOU			OHD			0.0012								
		Multiple Tandem Switching, per MOU (applies to intial tandem only)			OHD			0.0012								
TRUNK CHARGE																
		Installation Trunk Side Service - per DS0			OHD	TPP++			333.54bk	56.88bk						
		Dedicated End Office Trunk Port Service-per DS0**			OHD	TDE0P		0.00								
		Dedicated End Office Trunk Port Service-per DS1**			OH1 OH1MS	TDE1P		0.00								
		Dedicated Tandem Trunk Port Service-per DS0**			OHD	TDW0P		0.00								
		Dedicated Tandem Trunk Port Service-per DS1**			OH1 OH1MS	TDW1P		0.00								
** This rate element is recovered on a per MOU basis and is included in the End Office Switching and Tandem Switching, per MOU rate elements																
COMMON TRANSPORT (Shared)																
		Common Transport - Per Mile, Per MOU			OHD			0.00001								
		Common Transport - Facilities Termination Per MOU			OHD			0.00034								
LOCAL INTERCONNECTION (TRANSPORT)																
INTEROFFICE CHANNEL - DEDICATED TRANSPORT - VOICE GRADE																
		Interoffice Channel - Dedicated Transport - 2-Wire Voice Grade - Per Mile per month			OHL, OHM	1L5NF		0.0282bk								
		Interoffice Channel - Dedicated Transport- 2- Wire Voice Grade- Facility Termination per month			OHL, OHM	1L5NF		18.00bk	52.58bk							
INTEROFFICE CHANNEL - DEDICATED TRANSPORT - 56/64 KBPS																
		Interoffice Channel - Dedicated Transport - 56 kbps - per mile per month			OHL, OHM	1L5NK		0.0282bk								
		Interoffice Channel - Dedicated Transport - 56 kbps - Facility Termination per month			OHL, OHM	1L5NK		17.40bk	52.58bk							
		Interoffice Channel - Dedicated Transport - 64 kbps - per mile per month			OHL, OHM	1L5NK		0.0282bk								
		Interoffice Channel - Dedicated Transport - 64 kbps - Facility Termination per month			OHL, OHM	1L5NK		17.40bk	52.58bk							
INTEROFFICE CHANNEL - DEDICATED TRANSPORT - DS1																
		Interoffice Channel - Dedicated Channel - DS1 - Per Mile per month			OH1, OH1MS	1L5NL		0.5753bk								
		Interoffice Channel - Dedicated Tranport - DS1 - Facility Termination per month			OH1, OH1MS	1L5NL		71.29bk	163.75bk							
INTEROFFICE CHANNEL - DEDICATED TRANSPORT- DS3																
		Interoffice Channel - Dedicated Transport - DS3 - Per Mile per month			OH3, OH3MS	1L5NM		12.98bk								
		Interoffice Channel - Dedicated Transport - DS3 - Facility Termination per month			OH3, OH3MS	1L5NM		720.38bk	579.55bk							
LOCAL CHANNEL - DEDICATED TRANSPORT																
		Local Channel - Dedicated - 2-Wire Voice Grade per month			OHL, OHM	TEFV2		14.82bk	553.80bk	89.69bk						
		Local Channel - Dedicated - 4-Wire Voice Grade per month			OHL, OHM	TEFV4		15.87bk	562.23bk	92.67bk						
		Local Channel - Dedicated - DS1 per month			OH1	TEFHG		35.68bk	534.48bk	462.69bk						
		Local Channel - Dedicated - DS3 Facility Termination per month			OH3	TEFHJ		498.87bk	562.25bk	527.88bk						
LOCAL INTERCONNECTION MID-SPAN MEET																
NOTE: If Access service ride Mid-Span Meet, one-half the tariffed service Local Channel rate is applicable.																
		Local Channel - Dedicated - DS1 per month			OH1MS	TEFHG		0.00	0.00							
		Local Channel - Dedicated - DS3 per month			OH3MS	TEFHJ		0.00	0.00							
MULTIPLEXERS																
		Channelization - DS1 to DS0 Channel System			OH1, OH1MS	SATN1		146.69bk	197.78bk	140.06bk						

LOCAL INTERCONNECTION - North Carolina										Attachment: 3				Exhibit: A		
CATEGORY	NOTES	RATE ELEMENTS	Interim	Zone	BCS	USOC	RATES(\$)				Svc Order Submitted Elec per LSR	Svc Order Submitted Manually per LSR	Incremental Charge - Manual Svc Order vs. Electronic-1st	Incremental Charge - Manual Svc Order vs. Electronic-Add'l	Incremental Charge - Manual Svc Order vs. Electronic-Disc 1st	Incremental Charge - Manual Svc Order vs. Electronic-Disc Add'l
							Rec	Nonrecurring		Nonrecurring Disconnect						
							First	Add'l	First	Add'l	SOME C	SOMAN	SOMAN	SOMAN	SOMAN	SOMAN
		DS3 to DS1 Channel System per month			OH3, OH3MS	SATNS	233.10bk	403.97bk	234.40bk							
		DS3 Interface Unit (DS1 COC) per month			OH1, OH1MS	SATCO	16.07bk	13.09bk	9.38bk							
Notes: If no rate is identified in the contract, the rates, terms, and conditions for the specific service or function will be as set forth in applicable BellSouth tariff.																

LOCAL INTERCONNECTION - South Carolina										Attachment: 3		Exhibit: A							
CATEGORY	NOTES	RATE ELEMENTS	Interim	Zone	BCS	USOC	RATES(\$)				Svc Order Submitted Elec per LSR	Svc Order Submitted Manually per LSR	Incremental Charge - Manual Svc Order vs. Electronic-1st	Incremental Charge - Manual Svc Order vs. Electronic-Add'l	Incremental Charge - Manual Svc Order vs. Electronic-Disc 1st	Incremental Charge - Manual Svc Order vs. Electronic-Disc Add'l			
							Rec	Nonrecurring		Nonrecurring Disconnect							OSS RATES (\$)		
										First	Add'l	First	Add'l	SOMEC	SOMAN	SOMAN	SOMAN	SOMAN	SOMAN
LOCAL INTERCONNECTION (CALL TRANSPORT AND TERMINATION)																			
NOTE: "bk" beside a rate indicates that the Parties have agreed to bill and keep for that element under certain circumstances pursuant to the terms and conditions in Attachment 3.																			
NOTE: The Parties will report a Percent Local Facility ("PLF") factor to one another to represent the percentage of switched dedicated facilities utilized for local traffic																			
COMPENSATION																			
		Single Rate for Local and ISP-bound Traffic (1/1/02 - 12/31/02)			OHD			.0015											
		Single Rate for Local and ISP-bound Traffic (1/1/03 - 12/31/03)			OHD			.001											
COMPENSATION FOR TRANSIT AND MTA TRAFFIC																			
		Tandem Switching Function Per MOU			OHD			0.000736											
		Multiple Tandem Switching, per MOU (applies to initial tandem only)			OHD			0.000736											
TRUNK CHARGE																			
		Installation Trunk Side Service - per DS0			OHD	TPP++		335.14bk	57.16bk										
		Dedicated End Office Trunk Port Service-per DS0**			OHD	TDE0P		0.00											
		Dedicated End Office Trunk Port Service-per DS1**			OH1	OH1MS		0.00											
		Dedicated Tandem Trunk Port Service-per DS0**			OHD	TDW0P		0.00											
		Dedicated Tandem Trunk Port Service-per DS1**			OH1	OH1MS		0.00											
** This rate element is recovered on a per MOU basis and is included in the End Office Switching and Tandem Switching, per MOU rate elements																			
COMMON TRANSPORT (Shared)																			
		Common Transport - Per Mile, Per MOU			OHD			0.0000045											
		Common Transport - Facilities Termination Per MOU			OHD			0.0004095											
LOCAL INTERCONNECTION (TRANSPORT)																			
INTEROFFICE CHANNEL - DEDICATED TRANSPORT - VOICE GRADE																			
		Interoffice Channel - Dedicated Transport - 2-Wire Voice Grade - Per Mile per month			OHL, OHM	1L5NF		0.0167bk											
		Interoffice Channel - Dedicated Transport- 2- Wire Voice Grade - Facility Termination per month			OHL, OHM	1L5NF		24.30bk	40.63bk					16.77bk					
INTEROFFICE CHANNEL - DEDICATED TRANSPORT - 56/64 KBPS																			
		Interoffice Channel - Dedicated Transport - 56 kbps - per mile per month			OHL, OHM	1L5NK		0.0167bk											
		Interoffice Channel - Dedicated Transport - 56 kbps - Facility Termination per month			OHL, OHM	1L5NK		16.76bk	40.63bk					16.77bk					
		Interoffice Channel - Dedicated Transport - 64 kbps - per mile per month			OHL, OHM	1L5NK		0.0167bk											
		Interoffice Channel - Dedicated Transport - 64 kbps - Facility Termination per month			OHL, OHM	1L5NK		16.76bk	40.63bk					16.77bk					
INTEROFFICE CHANNEL - DEDICATED TRANSPORT - DS1																			
		Interoffice Channel - Dedicated Channel - DS1 - Per Mile per month			OH1, OH1MS	1L5NL		0.3415bk											
		Interoffice Channel - Dedicated Transport - DS1 - Facility Termination per month			OH1, OH1MS	1L5NL		77.14bk	89.47bk					16.39bk					
INTEROFFICE CHANNEL - DEDICATED TRANSPORT- DS3																			
		Interoffice Channel - Dedicated Transport - DS3 - Per Mile per month			OH3, OH3MS	1L5NM		8.02bk											
		Interoffice Channel - Dedicated Transport - DS3 - Facility Termination per month			OH3, OH3MS	1L5NM		880.65bk	279.37bk					60.33bk					
LOCAL CHANNEL - DEDICATED TRANSPORT																			
		Local Channel - Dedicated - 2-Wire Voice Grade per month			OHL, OHM	TEFV2		15.33bk	193.53bk	33.24bk			36.72bk		3.21bk				
		Local Channel - Dedicated - 4-Wire Voice Grade per month			OHL, OHM	TEFV4		16.54bk	193.97bk	33.68bk			37.19bk		3.68bk				
		Local Channel - Dedicated - DS1 per month			OH1	TEFHG		42.62bk	177.87bk	154.06bk			22.24bk		15.30bk				
		Local Channel - Dedicated - DS3 Facility Termination per month			OH3	TEFHJ		446.00bk	452.52bk	264.53bk			119.75bk		83.77bk				
LOCAL INTERCONNECTION MID-SPAN MEET																			
NOTE: If Access service ride Mid-Span Meet, one-half the tariffed service Local Channel rate is applicable.																			
		Local Channel - Dedicated - DS1 per month			OH1MS	TEFHG		0.00	0.00										
		Local Channel - Dedicated - DS3 per month			OH3MS	TEFHJ		0.00	0.00										
MULTIPLXERS																			
		Channelization - DS1 to DS0 Channel System			OH1, OH1MS	SATN1		107.57bk	91.24bk	62.71bk			10.56bk		9.81bk				
		DS3 to DS1 Channel System per month			OH3, OH3MS	SATNS		144.02bk	178.54bk	94.18bk			33.33bk		31.90bk				
		DS3 Interface Unit (DS1 COCI) per month			OH1, OH1MS	SATCO		8.64bk	6.59bk	4.73bk									
Notes: If no rate is identified in the contract, the rates, terms, and conditions for the specific service or function will be as set forth in applicable BellSouth tariff.																			

LOCAL INTERCONNECTION - Tennessee										Attachment: 3		Exhibit: A														
CATEGORY	NOTES	RATE ELEMENTS	Interim	Zone	BCS	USOC	RATES(\$)				Svc Order Submitted Elec per LSR	Svc Order Submitted Manually per LSR	Incremental Charge - Manual Svc Order vs. Electronic-1st	Incremental Charge - Manual Svc Order vs. Electronic-Add'l	Incremental Charge - Manual Svc Order vs. Electronic-Disc 1st	Incremental Charge - Manual Svc Order vs. Electronic-Disc Add'l										
							Rec	Nonrecurring First	Add'l	Nonrecurring Disconnect First							Add'l	OSS RATES (\$)								
																SOMEC	SOMAN	SOMAN	SOMAN	SOMAN	SOMAN					
LOCAL INTERCONNECTION (CALL TRANSPORT AND TERMINATION)																										
NOTE: "bk" beside a rate indicates that the Parties have agreed to bill and keep for that element under certain circumstances pursuant to the terms and conditions in Attachment 3.																										
NOTE: The Parties will report a Percent Local Facility ("PLF") factor to one another to represent the percentage of switched dedicated facilities utilized for local traffic.																										
COMPENSATION																										
		Single Rate for Local and ISP-bound Traffic (1/1/02 - 12/31/02)			OHD			.0015																		
		Single Rate for Local and ISP-bound Traffic (1/1/03 - 12/31/03)			OHD			.001																		
COMPENSATION FOR TRANSIT AND MTA TRAFFIC																										
		Tandem Switching Function Per MOU			OHD			0.0009778																		
		Multiple Tandem Switching, per MOU (applies to initial tandem only)			OHD			0.0009778																		
TRUNK CHARGE																										
		Installation Trunk Side Service - per DS0			OHD	TPP++			334.29bk	57.01bk																
		Dedicated End Office Trunk Port Service-per DS0**			OHD	TDE0P		0.00																		
		Dedicated End Office Trunk Port Service-per DS1**			OH1	OH1MS		0.00																		
		Dedicated Tandem Trunk Port Service-per DS0**			OHD	TDW0P		0.00																		
		Dedicated Tandem Trunk Port Service-per DS1**			OH1	OH1MS		0.00																		
** This rate element is recovered on a per MOU basis and is included in the End Office Switching and Tandem Switching, per MOU rate elements																										
COMMON TRANSPORT (Shared)																										
		Common Transport - Per Mile, Per MOU			OHD			0.0000064																		
		Common Transport - Facilities Termination Per MOU			OHD			0.0003871																		
LOCAL INTERCONNECTION (TRANSPORT)																										
INTEROFFICE CHANNEL - DEDICATED TRANSPORT - VOICE GRADE																										
		Interoffice Channel - Dedicated Transport - 2-Wire Voice Grade - Per Mile per month			OHL, OHM	1L5NF		0.0174bk																		
		Interoffice Channel - Dedicated Transport- 2- Wire Voice Grade - Facility Termination per month			OHL, OHM	1L5NF		18.58bk	17.37bk		3.51bk															
INTEROFFICE CHANNEL - DEDICATED TRANSPORT - 56/64 KBPS																										
		Interoffice Channel - Dedicated Transport - 56 kbps - per mile per month			OHL, OHM	1L5NK		0.0174bk																		
		Interoffice Channel - Dedicated Transport - 56 kbps - Facility Termination per month			OHL, OHM	1L5NK		17.98bk	17.37bk		3.51bk															
		Interoffice Channel - Dedicated Transport - 64 kbps - per mile per month			OHL, OHM	1L5NK		0.0174bk																		
		Interoffice Channel - Dedicated Transport - 64 kbps - Facility Termination per month			OHL, OHM	1L5NK		17.98bk	17.37bk		3.51bk															
INTEROFFICE CHANNEL - DEDICATED TRANSPORT - DS1																										
		Interoffice Channel - Dedicated Channel - DS1 - Per Mile per month			OH1, OH1MS	1L5NL		0.3562bk																		
		Interoffice Channel - Dedicated Transport - DS1 - Facility Termination per month			OH1, OH1MS	1L5NL		77.86bk	76.27bk		14.99bk															
INTEROFFICE CHANNEL - DEDICATED TRANSPORT- DS3																										
		Interoffice Channel - Dedicated Transport - DS3 - Per Mile per month			OH3, OH3MS	1L5NM		2.34bk																		
		Interoffice Channel - Dedicated Transport - DS3 - Facility Termination per month			OH3, OH3MS	1L5NM		848.99bk	176.56bk		105.91bk															
LOCAL CHANNEL - DEDICATED TRANSPORT																										
		Local Channel - Dedicated - 2-Wire Voice Grade per month			OHL, OHM	TEFV2		19.43bk	199.33bk	24.16bk	54.81bk	4.80bk														
		Local Channel - Dedicated - 4-Wire Voice Grade per month			OHL, OHM	TEFV4		20.56bk	201.53bk	24.83bk	55.52bk	5.51bk														
		Local Channel - Dedicated - DS1 per month			OH1	TEFHG		40.99bk	277.35bk	233.26bk	33.18bk	22.30bk														
		Local Channel - Dedicated - DS3 Facility Termination per month			OH3	TEFHJ		611.30bk	595.37bk	304.50bk	215.82bk	151.15bk														
LOCAL INTERCONNECTION MID-SPAN MEET																										
NOTE: If Access service ride Mid-Span Meet, one-half the tariffed service Local Channel rate is applicable.																										
		Local Channel - Dedicated - DS1 per month			OH1MS	TEFHG		0.00	0.00																	
		Local Channel - Dedicated - DS3 per month			OH3MS	TEFHJ		0.00	0.00																	
MULTIPLXERS																										
		Channelization - DS1 to DS0 Channel System			OH1, OH1MS	SATN1		80.77bk	141.87bk	77.11bk	44.47bk	42.62bk														
		DS3 to DS1 Channel System per month			OH3, OH3MS	SATNS		222.98bk	308.03bk	108.47bk	6.34bk	4.23bk														
		DS3 Interface Unit (DS1 COCJ) per month			OH1, OH1MS	SATCO		17.58bk	6.07bk	4.66bk																
Notes: If no rate is identified in the contract, the rates, terms, and conditions for the specific service or function will be as set forth in applicable BellSouth tariff.																										