

BELLSOUTH® / CLEC Agreement

Customer Name: Adelphia Business Solutions of Kentucky, Inc.

| | |
|--|-----|
| Adelphia Kentucky Renegotiation | 2 |
| Table of Contents | 3 |
| General Terms and Conditions | 5 |
| ATT01Resale | 29 |
| ATT01Rates | 69 |
| ATT02UNEDocument | 70 |
| ATT02Rates | 175 |
| ATT03Local Interconnection | 254 |
| ATT03Rates | 287 |
| ATT04Collocation | 294 |
| ATT05Number Portability | 353 |
| ATT05Rates | 362 |
| ATT06Ordering,Provisioning | 363 |
| ATT07Billing | 369 |
| ATT07Rates | 389 |
| ATT08ROW | 390 |
| ATT09Performance Measurements | 392 |
| ATT10Implementation | 499 |
| ATT11DisasterRecoveryPlan | 509 |
| ATT12BFR | 520 |
| Adelphia Kentucky Amendment | 526 |
| Adelphia Business Solutions- Ky Ordinarily Comb & Expedite | 534 |
| Adelphia - Amend KY Term, EELs, ISP, etc | 538 |

**INTERCONNECTION
AGREEMENT
BETWEEN
BELLSOUTH TELECOMMUNICATIONS INC.
AND
Adelphia Business Solutions of Kentucky, Inc.**

**AGREEMENT
BETWEEN
BELLSOUTH TELECOMMUNICATIONS, INC.**

AND

ADELPHIA BUSINESS SOLUTIONS OF KENTUCKY, INC.

TABLE OF CONTENTS

General Terms and Conditions

Part A

1. Purpose
2. Term of the Agreement
3. Ordering Procedures
4. Parity
5. White Pages Listings
6. Bona Fide Request/New Business Request Process for Further Unbundling
7. Court Ordered Requests for Call Detail Records and Other Subscriber Information
8. Liability and Indemnification
9. Intellectual Property Rights and Indemnification
10. Proprietary and Confidential Information
11. Assignments
12. Resolution of Disputes
13. Taxes
14. Force Majeure
15. Modification of Agreement
15. Waivers
17. Governing Law
18. Arm's Length Negotiations
19. Notices
20. Rule of Construction
21. Headings of No Force or Effect
22. Multiple Counterparts
23. Implementation of Agreement
24. Interference or Impairment
25. Filing of Agreement
26. Guides
27. Entire Agreement

Part B - Definitions

Attachment 1 - Resale

Attachment 2 - Network Elements and Other Services

Attachment 3 - Network Interconnection

Attachment 4 - Physical Collocation

Attachment 5 - Access to Numbers and Number Portability

Attachment 6 - Ordering and Provisioning

Attachment 7 - Billing and Billing Accuracy Certification

Attachment 8 - Rights-of-Way, Conduits and Pole Attachments

Attachment 9 - Performance Measurements

Attachment 10- Agreement Implementation Template

Attachment 11 – BellSouth Disaster Recovery Plan

Attachment 12 – Bona Fide Request/New Business Request

AGREEMENT

THIS AGREEMENT is made by and between BellSouth Telecommunications, Inc., (“BellSouth”), a Georgia corporation, and Adelphia Business Solutions of Kentucky, Inc. (“Adelphia”), a Delaware corporation, and shall be deemed effective as of August 21, 2000. This Agreement may refer to either BellSouth or Adelphia or both as a “Party” or “Parties.”

WITNESSETH

WHEREAS, BellSouth is a local exchange telecommunications company authorized to provide telecommunications services in the states of Alabama, Florida, Georgia, Kentucky, Louisiana, Mississippi, North Carolina, South Carolina; and

WHEREAS, Adelphia is or seeks to become a competitive local exchange telecommunications company (“CLEC”) authorized to provide telecommunications services in the state of Kentucky; and

WHEREAS, the Parties wish to resell BellSouth’s telecommunications services and/or interconnect their facilities, purchase network elements and other services, and exchange traffic pursuant to sections 251 and 252 of the Telecommunications Act of 1996 (“the Act”).

NOW THEREFORE, in consideration of the mutual agreements contained herein, BellSouth and Adelphia agree as follows:

1. Purpose

The resale, access and interconnection obligations contained herein are intended to be performed in accordance with Sections 251 and 252 of the Act, and designed to enable Adelphia to provide competing telephone exchange and exchange access service to subscribers within the territory of BellSouth.

2. Term of the Agreement

2.1 This Agreement shall be effective upon execution by both Parties, shall expire December 31, 2002, and shall apply to the state of Kentucky. Upon mutual written agreement of the Parties, this Agreement may be renewed for such additional period of time as the Parties may agree.

2.2 The Parties agree that if either Party provides notice of intent to renegotiate no later than one hundred and eighty (180) days prior, and no sooner than two hundred and seventy (270) days prior, to the expiration of this Agreement, they shall negotiate as soon as practicable with regard to the terms, conditions and prices of resale and/or local interconnection to be effective beginning on the expiration date of this Agreement (“Subsequent Agreement”). If as of the expiration of this Agreement a Subsequent Agreement has not been executed by

both of the Parties, this Agreement shall continue on a month-to-month basis until a Subsequent Agreement is negotiated or arbitrated. The Parties' rights and obligations with respect to this Agreement after expiration shall be as set forth in Section 2.4 below.

2.3 If, within one hundred and thirty-five (135) to one hundred and sixty (160) days of commencing the negotiation referred to in Section 2.2 above, the Parties are unable to satisfactorily negotiate new resale and/or local interconnection terms, conditions and prices, either Party may petition the Commission to establish appropriate local interconnection and/or resale arrangements pursuant to 47 U.S.C. 252. The Parties agree that, in such event, they shall encourage the Commission to issue its order regarding the appropriate local interconnection and/or resale arrangements no later than the expiration date of this Agreement. The Parties further agree that in the event the Commission does not issue its order prior to the expiration date of this Agreement, or if the Parties continue beyond the expiration date of this Agreement to negotiate the local interconnection and/or resale arrangements without Commission intervention, the terms, conditions and prices ultimately ordered by the Commission, or negotiated by the Parties, will be effective retroactive to the day following the expiration date of this Agreement.

2.4 In the event that as of the date of expiration of this Agreement and conversion of this Agreement to a month-to-month term, the Parties have not entered into a Subsequent Agreement and (i) the Parties are not involved in active good faith negotiations or mediation for a Subsequent Agreement and (ii) no arbitration proceeding has been filed in accordance with Section 2.3 above, then either Party may terminate this Agreement upon sixty (60) days written notice to the other Party. In the event that BellSouth terminates this Agreement as provided above, BellSouth shall continue to offer services to Adelphia pursuant to the terms, conditions and rates set forth in BellSouth's Statement of Generally Available Terms (SGAT) to the extent an SGAT has been approved by the applicable Commission(s). If any state Commission has not approved a BellSouth SGAT, then upon BellSouth's termination of this Agreement as provided herein, BellSouth will continue to provide services to Adelphia pursuant to BellSouth's then current standard interconnection agreement. In the event that the SGAT or BellSouth's standard interconnection agreement becomes effective as between the Parties, the Parties may continue to negotiate a Subsequent Agreement, and the terms of such Subsequent Agreement shall be effective retroactive to the day following expiration of this Agreement.

3. Ordering Procedures

3.1 The Parties agree to adhere to the BellSouth Local Interconnection and Facility Based Ordering Guide, Products and Services Interval Guide, Resale Ordering Guide, Work Center Operational Understanding Agreement, and such other BellSouth Guides referenced herein (together, "Guides") as appropriate for the services ordered.

3.2 Adelphia shall pay charges for Operational Support Systems (OSS) as set forth in this Agreement in Attachment 1 and/or in Attachment 2, 3, 5 and 7 as applicable.

4. Parity

When Adelphia purchases, pursuant to Attachment 1 of this Agreement, telecommunications services from BellSouth for the purposes of resale to end users, BellSouth shall provide said services so that the services are equal in quality, subject to the same conditions, and provided within the same provisioning time intervals that BellSouth provides to its affiliates, subsidiaries, end users or any other third-party carrier. To the extent technically feasible, the quality of a Network Element, as well as the quality of the access to such Network Element provided by BellSouth to Adelphia shall be at least equal in quality to that which BellSouth provides to itself. The quality of the interconnection between the networks of BellSouth and the network of Adelphia shall be at a level that is equal to that which BellSouth provides itself, a subsidiary, an Affiliate, or any other party. The interconnection facilities shall be designed to meet the same technical criteria and service standards that are used within BellSouth's network and shall extend to a consideration of service quality as perceived by end users and service quality as perceived by Adelphia.

5. White Pages Listings

BellSouth shall provide Adelphia and their customers access to white pages directory listings under the following terms:

5.1 Listings. Adelphia shall provide all new, changed and deleted listings on a timely basis and BellSouth or its agent will include Adelphia residential and business customer listings in the appropriate White Pages (residential and business) or alphabetical directories. Directory listings will make no distinction between Adelphia and BellSouth subscribers. BellSouth shall use commercially reasonable efforts at parity to ensure the accurate listing of Adelphia customers.

5.2 Rates. Subscriber primary listing information in the White Pages shall be provided at no charge to Adelphia or its subscribers and Adelphia will provide subscriber listing information to BellSouth at no charge; provided however, that orders regarding directory listings submitted separately from service orders will incur charges as stated in BellSouth's General Subscriber Services Tariff A.4.

5.3 Procedures for Submitting Adelphia Subscriber Listing Information are found in BellSouth's Ordering Guide for manually processed listings and in the Local Exchange Ordering Guide for mechanically submitted listings.

5.3.1 Notwithstanding any provision(s) to the contrary, Adelphia agrees to provide to BellSouth, and BellSouth agrees to accept, Adelphia's Subscriber Listing

Information (SLI) relating to Adelphia's customers in the geographic area(s) covered by this Interconnection Agreement. Adelphia authorizes BellSouth to release all such Adelphia SLI provided to BellSouth by Adelphia to qualifying third parties via either license agreement or BellSouth's Directory Publishers Database Service (DPDS), General Subscriber Services Tariff, Section A38.2, as the same may be amended from time to time. Such CLEC SLI shall be intermingled with BellSouth's own customer listings of any other CLEC that has authorized a similar release of SLI. Where necessary, BellSouth will use good faith efforts to obtain state commission approval of any necessary modifications to Section A38.2 of its tariff to provide for release of third party directory listings, including modifications regarding listings to be released pursuant to such tariff and BellSouth's liability thereunder. BellSouth's obligation pursuant to this Section shall not arise in any particular state until the commission of such state has approved modifications to such tariff.

- 5.3.2 No compensation shall be paid to Adelphia for BellSouth's receipt of Adelphia SLI, or for the subsequent release to third parties of such SLI. Adelphia agrees that, to the extent BellSouth incurs costs to modify its systems to enable the release of Adelphia's SLI, or costs on an ongoing basis to administer the release of Adelphia SLI, Adelphia shall pay to BellSouth its proportionate share of the reasonable costs associated therewith. Before BellSouth incurs any costs under this Section, it shall inform Adelphia of its good faith estimate of Adelphia's share of such costs, and Adelphia shall have the option of agreeing in writing to the costs, or of discontinuing BellSouth's release of Adelphia's SLI.
- 5.3.3 BellSouth shall not be liable for the content or accuracy of any SLI provided by Adelphia under this Agreement. Adelphia shall indemnify, hold harmless and defend BellSouth from and against any damages, losses, liabilities, demands claims, suits, judgments, costs and expenses (including but not limited to reasonable attorneys' fees and expenses) arising from BellSouth's tariff obligations or otherwise and resulting from or arising out of any third party's claim of inaccurate Adelphia listings or use of the SLI provided pursuant to this Agreement. BellSouth shall forward to Adelphia any complaints received by BellSouth relating to the accuracy or quality of Adelphia listings.
- 5.3.4 Listings and subsequent updates will be released consistent with BellSouth system changes and/or update scheduling requirements.
- 5.3.5 If at any time during the term of this Agreement Adelphia elects to discontinue BellSouth's release of Adelphia SLI to third parties, Adelphia shall provide BellSouth 60 days prior written notice of such election and the Parties shall amend this agreement to effect such election.
- 5.4 Unlisted/Non-Published Subscribers. Adelphia will be required to provide to BellSouth the names, addresses and telephone numbers of all Adelphia customers that wish to be omitted from directories.

- 5.5 Inclusion of Adelphia Customers in Directory Assistance Database. BellSouth will include and maintain Adelphia subscriber listings in BellSouth's Directory Assistance databases at no recurring charge and Adelphia shall provide such Directory Assistance listings at no recurring charge. BellSouth and Adelphia will formulate appropriate procedures regarding lead-time, timeliness, format, content, and correction of listing information.
- 5.6 Listing Information Confidentiality. BellSouth will accord Adelphia's SLI the same level of confidentiality that BellSouth accords its own SLI, and BellSouth shall limit access to Adelphia's SLI to those BellSouth employees who are involved in the preparation of listings.
- 5.7 Optional Listings. Additional listings and optional listings will be offered by BellSouth at tariffed rates as set forth in the General Subscriber Services Tariff.
- 5.8 Delivery. BellSouth or its agent shall deliver White Pages directories to Adelphia subscribers at no charge and in the same manner, time and quantity as it provides its own customers.

6. Bona Fide Request/New Business Request Process for Further Unbundling

- 6.1 BellSouth shall, upon request of Adelphia, provide to Adelphia access to its network elements at any technically feasible point for the provision of Adelphia's telecommunications service in accordance with applicable law and Commission and FCC rules and orders. Any request by Adelphia for access to a network element, interconnection option, or for the provisioning of any service or product that is not already available shall be treated as a Bona Fide Request/New Business Request, and shall be submitted to BellSouth pursuant to the Bona Fide Request/New Business Request process set forth in Attachment 12.

7. Court Ordered Requests for Call Detail Records and Other Subscriber Information

To the extent technically feasible, where BellSouth provides resale or local switching to Adelphia, BellSouth maintains call detail records for Adelphia end users for limited time periods and can respond to subpoenas and court ordered requests for this information. BellSouth shall maintain such information for Adelphia end users for the same length of time it maintains such information for its own end users.

- 7.1 BellSouth will respond to subpoenas and court ordered requests delivered directly to BellSouth for the purpose of providing call detail records when the targeted telephone numbers belong to Adelphia end users and where BellSouth maintains call detail records responsive to the law enforcement agency subpoena or court ordered request. Billing for such requests will be generated by BellSouth and

directed to the law enforcement agency initiating the request. If BellSouth does not maintain the call detail records, BellSouth will direct the law enforcement agency initiating the request to Adelphia.

- 7.2 Adelphia agrees that in cases where Adelphia receives subpoenas or court ordered requests for call detail records for targeted telephone numbers belonging to Adelphia end users, if Adelphia does not maintain the call detail records responsive to such requests, Adelphia will advise the law enforcement agency initiating the request to redirect the subpoena or court ordered request to BellSouth. Billing for call detail information will be generated by BellSouth and directed to the law enforcement agency initiating the request.
- 7.3 Adelphia will provide Adelphia end user and/or other customer information that is available to Adelphia in response to subpoenas and court orders for their own customer records. BellSouth will redirect subpoenas and court ordered requests for Adelphia end user and/or other customer information to Adelphia for the purpose of providing this information to the law enforcement agency.

8. Liability and Indemnification

- 8.1 BellSouth shall take financial responsibility for its own actions in causing, or its lack of action in preventing, unbillable or uncollectible Adelphia revenues. Adelphia shall take financial responsibility for its own actions in causing, or its lack of action in preventing, unbillable or uncollectible BellSouth revenues.
- 8.2 In the event that Adelphia consists of two (2) or more separate entities as set forth in the preamble to this Agreement, all such entities shall be jointly and severally liable for the obligations of Adelphia under this Agreement.
- 8.3 Liability for Acts or Omissions of Third Parties. Neither BellSouth nor Adelphia shall be liable for any act or omission of another telecommunications company providing a portion of the services provided under this Agreement.
- 8.4 Limitation of Liability.
- 8.4.1 Except in the event of the gross negligence or willful misconduct of the Party seeking to rely on the limitation of liability in this Section, each Party's liability to the other for any loss, cost, claim, injury or liability or expense, including reasonable attorneys' fees, relating to or arising out of any negligent act or omission in its performance of this Agreement, whether in contract or in tort, shall be limited to a credit for the actual cost of the services or functions not performed or performed improperly. To the extent that any other specific provision or provisions of this Agreement include a limitation of liability that is inconsistent with this Section, the limitation of liability associated with such specific provision or provisions shall apply, rather than this Section, in the event of any claim arising

under the specific provision or provisions. In addition, this limitation of liability shall not apply to a Party's indemnification obligations under this Agreement.

- 8.4.2 Limitations in Tariffs and Contracts. A Party may, in its sole discretion, provide in its tariffs and contracts with its Customer and third parties that relate to any service, product or function provided or contemplated under this Agreement, that to the maximum extent permitted by Applicable Law, such Party shall not be liable to Customer or third Party for (i) any Loss relating to or arising out of this Agreement, whether in contract, tort or otherwise, that exceeds the amount such Party would have charged that applicable person for the service, product or function that gave rise to such Loss and (ii) Consequential Damages. To the extent that a Party elects not to place in its tariffs or contracts such limitations of liability, and the other Party incurs a Loss as a result thereof, such Party shall indemnify and reimburse the other Party for that portion of the Loss that would have been limited had the first Party included in its tariffs and contracts the limitations of liability that such other Party included in its own tariffs at the time of such Loss. Any such tariff term or condition shall not modify the obligations of the Parties to each other under this Agreement and in the event of a conflict, this Agreement shall control.
- 8.4.3 Neither BellSouth nor Adelphia shall be liable for damages to the other's terminal location, POI or other Party's customers' premises resulting from the furnishing of a service, including, but not limited to, the installation and removal of equipment or associated wiring, except to the extent caused by a Party's negligence or willful misconduct or by a Party's failure to properly ground a local loop after disconnection.
- 8.4.4 Except in the case of willful misconduct or gross negligence, a Party shall not be responsible or liable for indirect, incidental, or consequential damages, including, but not limited to, economic loss or lost business or profits, damages arising from the use or performance of equipment or software, or the loss of use of software or equipment, or accessories attached thereto, delay, error, or loss of data. In connection with this limitation of liability, each Party recognizes that the other Party may, from time to time, provide advice, make recommendations, or supply other analyses related to the Services, or facilities described in this Agreement, and, while each Party shall use diligent efforts in this regard, the Parties acknowledge and agree that this limitation of liability shall apply to provision of such advice, recommendations, and analyses.
- 8.5 Indemnification for Certain Claims. The Party providing services hereunder, its affiliates and its parent company, shall be indemnified, defended and held harmless by the Party receiving services hereunder against any claim, loss or damage arising from the receiving Party's use of the services provided under this Agreement pertaining to claims for libel, slander or invasion of privacy arising from the content of the receiving Party's own communications.

8.6 Nothing in this Agreement shall be construed to require indemnification in excess of that permitted by law and, to the extent any part of this Agreement is found to be invalid or unenforceable, the Parties agree that the obligation to indemnify under this Agreement shall be enforced to the fullest extent permitted in the relevant jurisdiction, excluding only such claims as are prohibited therein.

8.7 Disclaimer. EXCEPT AS SPECIFICALLY PROVIDED TO THE CONTRARY IN THIS AGREEMENT, NEITHER PARTY MAKES ANY REPRESENTATIONS OR WARRANTIES TO THE OTHER PARTY CONCERNING THE SPECIFIC QUALITY OF ANY SERVICES, OR FACILITIES PROVIDED UNDER THIS AGREEMENT. THE PARTIES DISCLAIM, WITHOUT LIMITATION, ANY WARRANTY OR GUARANTEE OF MERCHANTABILITY OR FITNESS FOR A PARTICULAR PURPOSE, ARISING FROM COURSE OF PERFORMANCE, COURSE OF DEALING, OR FROM USAGES OF TRADE.

9. **Intellectual Property Rights and Indemnification**

9.1 No License. No patent, copyright, trademark or other proprietary right is licensed, granted or otherwise transferred by this Agreement. Adelpia is strictly prohibited from any use, including but not limited to in sales, in marketing or advertising of telecommunications services, of any BellSouth name, service mark or trademark. BellSouth is strictly prohibited from any use, including but not limited to in sales, in marketing or advertising of telecommunications services, of any Adelpia name, service mark or trade mark.

9.2 Ownership of Intellectual Property. Any intellectual property which originates from or is developed by a Party shall remain in the exclusive ownership of that Party. Except for a limited license to use patents or copyrights to the extent necessary for the Parties to use any facilities or equipment (including software) or to receive any service solely as provided under this Agreement, no license in patent, copyright, trademark or trade secret, or other proprietary or intellectual property right now or hereafter owned, controlled or licensable by a Party, is granted to the other Party or shall be implied or arise by estoppel. It is the responsibility of each Party to ensure at no additional cost to the other Party that it has obtained any necessary licenses in relation to intellectual property of third Parties used in its network that may be required to enable the other Party to use any facilities or equipment (including software), to receive any service, or to perform its respective obligations under this Agreement.

9.3 Indemnification. The Party providing a service pursuant to this Agreement will defend the Party receiving such service or data provided as a result of such service against claims of infringement arising solely from the use by the receiving Party of such service and will indemnify the receiving Party for any damages awarded based solely on such claims in accordance with Section 8 of this Agreement.

9.4 Claim of Infringement. In the event that use of any facilities or equipment (including software), becomes, or in reasonable judgment of the Party who owns the affected network is likely to become, the subject of a claim, action, suit, or proceeding based on intellectual property infringement, then said Party shall promptly and at its sole expense, but subject to the limitations of liability set forth below:

9.4.1 modify or replace the applicable facilities or equipment (including software) while maintaining form and function, or

9.4.2 obtain a license sufficient to allow such use to continue.

9.4.3 In the event 9.4.1 or 9.4.2 are commercially unreasonable, then said Party may, terminate, upon reasonable notice, this contract with respect to use of, or services provided through use of, the affected facilities or equipment (including software), but solely to the extent required to avoid the infringement claim.

9.5 Exception to Obligations. Neither Party's obligations under this Section shall apply to the extent the infringement is caused by: (i) modification of the facilities or equipment (including software) by the indemnitee; (ii) use by the indemnitee of the facilities or equipment (including software) in combination with equipment or facilities (including software) not provided or authorized by the indemnitor provided the facilities or equipment (including software) would not be infringing if used alone; (iii) conformance to specifications of the indemnitee which would necessarily result in infringement; or (iv) continued use by the indemnitee of the affected facilities or equipment (including software) after being placed on notice to discontinue use as set forth herein.

9.6 Exclusive Remedy. The foregoing shall constitute the Parties' sole and exclusive remedies and obligations with respect to a third party claim of intellectual property infringement arising out of the conduct of business under this Agreement.

10. Proprietary and Confidential Information

10.1 Proprietary and Confidential Information: Defined. It may be necessary for BellSouth and Adelphia, each as the “Discloser,” to provide to the other party, as “Recipient,” certain proprietary and confidential information(including trade secret information) including but not limited to technical, financial, marketing, staffing and business plans and information, strategic information, , proposals, request for proposals, specifications, drawings, prices, costs, procedures, processes, business systems, software programs, techniques, customer account data, call detail records and like information (collectively the Discloser’s “Information”). All Information shall be provided to Recipient in written or other tangible or electronic form, clearly marked with a confidential and, proprietary notice . Information orally or visually provided to Recipient must be designated by Discloser as confidential and proprietary at the time of such disclosure and must be reduced to writing marked

with a confidential and proprietary notice and provided to Recipient within thirty (30) calendar days after such oral or visual disclosure.

- 10.2 Use and Protection of Information. Recipient shall use the Information solely for the purpose(s) of performing this Agreement, and Recipient shall protect Information from any use, distribution or disclosure except as permitted hereunder. Recipient will use the same standard of care to protect Information as Recipient uses to protect its own similar confidential and proprietary information, but not less than a reasonable standard of care. Recipient may disclose Information solely to the Authorized Representatives of the Recipient who (a) have a substantive need to know such Information in connection with performance of the Agreement; (b) have been advised of the confidential and proprietary nature of the Information; and (c) have personally agreed in writing to protect from unauthorized disclosure all confidential and proprietary information, of whatever source, to which they have access in the course of their employment. “Authorized Representatives” are the officers, directors and employees of Recipient and its Affiliates, as well as Recipient’s and its Affiliates’ consultants, contractors, counsel and agents. “Affiliates” means any company that is owned in whole or in part, now or in the future, directly or indirectly through a subsidiary, by a party hereto.
- 10.3 Ownership, Copying & Return of Information. Information remains at all times the property of Discloser. Recipient may make tangible or electronic copies, notes, summaries or extracts of Information only as necessary for use as authorized herein. All such tangible or electronic copies, notes, summaries or extracts must be marked with the same confidential and proprietary notice as appears on the original. Upon Discloser’s request, all or any requested portion of the Information (including, but not limited to, tangible and electronic copies, notes, summaries or extracts of any information) will be promptly returned to Discloser or destroyed, and Recipient will provide Discloser with written certification stating that such Information has been returned or destroyed.
- 10.4 Exceptions. Discloser’s Information does not include: (a) any information publicly disclosed by Discloser; (b) any information Discloser in writing authorizes Recipient to disclose without restriction; (c) any information already lawfully known to Recipient at the time it is disclosed by the Discloser, without an obligation to keep confidential; or (d) any information Recipient lawfully obtains from any source other than Discloser, provided that such source lawfully disclosed and/or independently developed such information. If Recipient is required to provide Information to any court or government agency pursuant to written court order, subpoena, regulation or process of law, Recipient must first provide Discloser with prompt written notice of such requirement and cooperate with Discloser to appropriately protect against or limit the scope of such disclosure. To the fullest extent permitted by law, Recipient will continue to protect as confidential and proprietary all Information disclosed in response to a written court order, subpoena, regulation or process of law.

- 10.5 Equitable Relief. Recipient acknowledges and agrees that any breach or threatened breach of this Agreement is likely to cause Discloser irreparable harm for which money damages may not be an appropriate or sufficient remedy. Recipient therefore agrees that Discloser or its Affiliates, as the case may be, are entitled to receive injunctive or other equitable relief to remedy or prevent any breach or threatened breach of this Agreement. Such remedy is not the exclusive remedy for any breach or threatened breach of this Agreement, but is in addition to all other rights and remedies available at law or in equity.
- 10.6 Survival of Confidentiality Obligations. The parties' rights and obligations under this Section 10 shall survive and continue in effect until two (2) years after the expiration or termination date of this Agreement with regard to all Information exchanged during the term of this Agreement. Thereafter, the parties' rights and obligations hereunder survive and continue in effect with respect to any Information that is a trade secret under applicable law.

11. Assignments

- 11.1 Any assignment by either Party to any non-affiliated entity of any right, obligation or duty, or of any other interest hereunder, in whole or in part, without the prior written consent of the other Party shall be void. A Party may assign this Agreement or any right, obligation, duty or other interest hereunder to an Affiliate company of the Party without the consent of the other Party. All obligations and duties of any Party under this Agreement shall be binding on all successors in interest and assigns of such Party. No assignment or delegation hereof shall relieve the assignor of its obligations under this Agreement in the event that the assignee fails to perform such obligations.

12. Resolution of Disputes

- 12.1 Each Party agrees to notify the other Party in writing of a dispute concerning this Agreement.
- 12.2 Procedures for resolution of billing disputes are set forth in Section 3 of Attachment 7 of this Agreement.
- 12.3 Procedures for resolution of all disputes other than billing disputes are set forth below.
- 12.3.1 If the Parties are unable to resolve the issues relating to the dispute in the normal course of business within 60 days after delivery of notice of the dispute, each of the Parties shall appoint a designated representative who has authority to settle the dispute and who is at a higher level of management than the persons with direct responsibility for administration of this Agreement. The designated representatives shall meet as often as they reasonably deem necessary in order to discuss the dispute and negotiate in good faith in an effort to resolve such dispute.

- 12.3.2 If the Parties are unable to resolve issues related to the dispute within thirty (30) days after the Parties' appointment of designated representatives pursuant to Section 12.3.1, then either Party may file a complaint with the Commission to resolve such issues or proceed with any other remedy pursuant to law or equity.
- 12.3.3 Nothing in this Section shall be construed to preclude or limit either Party from seeking immediate injunctive relief from a court or agency with competent jurisdiction to the extent it deems necessary. Each Party reserves any rights it may have to seek judicial review of any ruling by the Commission concerning this Agreement.

13. Taxes

- 13.1 Definition. For purposes of this Section, the terms "taxes" and "fees" shall include but not limited to federal, state or local sales, use, excise, gross receipts or other taxes or tax-like fees of whatever nature and however designated (including tariff surcharges and any fees, charges or other payments, contractual or otherwise, for the use of public streets or rights of way, whether designated as franchise fees or otherwise) imposed, or sought to be imposed, on or with respect to the services furnished hereunder or measured by the charges or payments therefore, excluding any taxes levied on income, real, or personal property.
- 13.2 Taxes and Fees Imposed Directly On Either Providing Party or Purchasing Party.
- 13.2.1 Taxes and fees imposed on the providing Party, which are not permitted or required to be passed on by the providing Party to its customer, shall be borne and paid by the providing Party.
- 13.2.2 Taxes and fees imposed on the purchasing Party, which are not required to be collected and/or remitted by the providing Party, shall be borne and paid by the purchasing Party.
- 13.3 Taxes and Fees Imposed on Purchasing Party But Collected And Remitted By Providing Party.
- 13.3.1 Taxes and fees imposed on the purchasing Party shall be borne by the purchasing Party, even if the obligation to collect and/or remit such taxes or fees is placed on the providing Party.
- 13.3.2 To the extent permitted by applicable law, any such taxes and/or fees shall be shown as separate items on applicable billing documents between the Parties. Each Party will use its best efforts to ensure that any such taxes or fees are billed or presented in a timely manner. Notwithstanding the foregoing, the purchasing Party shall remain liable for any such taxes and fees regardless of whether they are

actually billed by the providing Party at the time that the respective service is billed.

- 13.3.3 If the purchasing Party determines that in its opinion any such taxes or fees are not payable, the providing Party shall not bill such taxes or fees to the purchasing Party if the purchasing Party provides written certification, reasonably satisfactory to the providing Party, stating that it is exempt or otherwise not subject to the tax or fee, setting forth the basis therefor, and satisfying any other requirements under applicable law. If any authority seeks to collect any such tax or fee that the purchasing Party has determined and certified not to be payable, or any such tax or fee that was not billed by the providing Party, the purchasing Party may contest the same in good faith, at its own expense. In any such contest, the purchasing Party shall promptly furnish the providing Party with copies of all filings in any proceeding, protest, or legal challenge, all rulings issued in connection therewith, and all correspondence between the purchasing Party and the taxing authority.
- 13.3.4 In the event that all or any portion of an amount sought to be collected must be paid in order to contest the imposition of any such tax or fee, or to avoid the existence of a lien on the assets of the providing Party during the pendency of such contest, the purchasing Party shall be responsible for such payment and shall be entitled to the benefit of any refund or recovery.
- 13.3.5 If it is ultimately determined that any additional amount of such a tax or fee is due to the imposing authority, the purchasing Party shall pay such additional amount, including any interest and penalties thereon.
- 13.3.6 Notwithstanding any provision to the contrary, the purchasing Party shall protect, indemnify and hold harmless (and defend at the purchasing Party's expense) the providing Party from and against any such tax or fee, interest or penalties thereon, or other charges or payable expenses (including reasonable attorney fees) with respect thereto, which are incurred by the providing Party in connection with any claim for or contest of any such tax or fee.
- 13.3.7 Each Party shall notify the other Party in writing of any assessment, proposed assessment or other claim for any additional amount of such a tax or fee by a taxing authority; such notice to be provided, if possible, at least ten (10) days prior to the date by which a response, protest or other appeal must be filed, but in no event later than thirty (30) days after receipt of such assessment, proposed assessment or claim.
- 13.4 Taxes and Fees Imposed on Providing Party But Passed On To Purchasing Party.
- 13.4.1 Taxes and fees imposed on the providing Party, which are permitted or required to be passed on by the providing Party to its customer, shall be borne by the purchasing Party.

- 13.4.2 To the extent permitted by applicable law, any such taxes and/or fees shall be shown as separate items on applicable billing documents between the Parties. Each Party will use its best efforts to ensure that any such taxes or fees are billed or presented in a timely manner. Notwithstanding the foregoing, the purchasing Party shall remain liable for any such taxes and fees regardless of whether they are actually billed by the providing Party at the time that the respective service is billed.
- 13.4.3 If the purchasing Party disagrees with the providing Party's determination as to the application or basis for any such tax or fee, the Parties shall consult with respect to the imposition and billing of such tax or fee. If, after consultation in accordance with the preceding sentence, the purchasing Party does not agree with the providing Party's final determination as to the application or basis of a particular tax or fee, and if the providing Party, after receipt of a written request by the purchasing Party to contest the imposition of such tax or fee with the imposing authority, fails or refuses to pursue such contest or to allow such contest by the purchasing Party, the purchasing Party may utilize the dispute resolution process outlined in this Agreement and Attachment 1. Utilization of the dispute resolution process shall not relieve the purchasing Party from liability for any tax or fee billed by the providing Party pursuant to this subsection during the pendency of such dispute resolution proceeding. In the event that the purchasing Party prevails in such dispute resolution proceeding, it shall be entitled to a refund in accordance with the final decision therein. Notwithstanding the foregoing, if at any time prior to a final decision in such dispute resolution proceeding the providing Party initiates a contest with the imposing authority with respect to any of the issues involved in such dispute resolution proceeding, the dispute resolution proceeding shall be dismissed as to such common issues and the final decision rendered in the contest with the imposing authority shall control as to such issues.
- 13.4.4 In the event that all or any portion of an amount sought to be collected must be paid in order to contest the imposition of any such tax or fee, or to avoid the existence of a lien on the assets of the providing Party during the pendency of such contest, the purchasing Party shall be responsible for such payment and shall be entitled to the benefit of any refund or recovery.
- 13.4.5 If it is ultimately determined that any additional amount of such a tax or fee is due to the imposing authority, the purchasing Party shall pay such additional amount, including any interest and penalties thereon.
- 13.4.6 Notwithstanding any provision to the contrary, the purchasing Party shall protect indemnify and hold harmless (and defend at the purchasing Party's expense) the providing Party from and against any such tax or fee, interest or penalties thereon, or other reasonable charges or payable expenses (including reasonable attorney fees) with respect thereto, which are incurred by the providing Party in connection with any claim for or contest of any such tax or fee.

- 13.4.7 Each Party shall notify the other Party in writing of any assessment, proposed assessment or other claim for any additional amount of such a tax or fee by a taxing authority; such notice to be provided, if possible, at least ten (10) days prior to the date by which a response, protest or other appeal must be filed, but in no event later than thirty (30) days after receipt of such assessment, proposed assessment or claim.
- 13.5 Mutual Cooperation. In any contest of a tax or fee by one Party, the other Party shall cooperate fully by providing records, testimony and such additional information or assistance as may reasonably be necessary to pursue the contest. Further, the other Party shall be reimbursed for any reasonable and necessary out-of-pocket copying and travel expenses incurred in assisting in such contest.

14. Force Majeure

In the event performance of this Agreement, or any obligation hereunder, is either directly or indirectly prevented, restricted, or interfered with by reason of fire, flood, earthquake or like acts of God, wars, revolution, civil commotion, explosion, acts of public enemy, embargo, acts of the government in its sovereign capacity, strikes, boycotts, or any other circumstances beyond the reasonable control and without the fault or negligence of the Party affected, the Party affected, upon giving prompt notice to the other Party, shall be excused from such performance on a day-to-day basis to the extent of such prevention, restriction, or interference (and the other Party shall likewise be excused from performance of its obligations on a day-to-day basis until the delay, restriction or interference has ceased); provided however, that the Party so affected shall use diligent efforts to avoid or remove such causes of non-performance and both Parties shall proceed whenever such causes are removed or cease. Each Party agrees to treat the other Party in parity with the manner in which it treats itself and any other entities with regard to a Force Majeure event.

15 Modification of Agreement

- 15.1 Upon written request, BellSouth shall make available, pursuant to 47 USC § 252 and the FCC rules and regulations regarding such availability, to Adelphia any interconnection, service, or network element provided under any other agreement filed and approved pursuant to 47 USC § 252. The adopted interconnection, service, or network element and agreement shall apply to the same states as such other agreement and for the identical term of such other agreement. The Parties shall adopt all rates, terms and conditions that are legitimately related to the individual interconnection, service, or network element being adopted.
- 15.2 If either Party changes its name or makes changes to its company structure or identity due to a merger, acquisition, transfer or any other reason, it is the responsibility of that Party to notify the other Party of said change and request that an amendment to this Agreement, if necessary, be executed to reflect said change.

- 15.3 No modification, amendment, supplement to, or waiver of the Agreement or any of its provisions shall be effective and binding upon the Parties unless it is made in writing and duly signed by the Parties.
- 15.4 Execution of this Agreement by either Party does not confirm or imply that the executing Party agrees with any decision(s) issued pursuant to the Telecommunications Act of 1996 and the consequences of those decisions on specific language in this Agreement. Neither Party waives its rights to appeal or otherwise challenge any such decision(s) and each Party reserves all of its rights to pursue any and all legal and/or equitable remedies, including appeals of any such decision(s).
- 15.5 In the event that any effective legislative, regulatory, judicial or other legal action materially affects any material terms of this Agreement, or the ability of Adelfhia or BellSouth to perform any material terms of this Agreement, Adelfhia or BellSouth may, on thirty (30) days' written notice require that such terms be renegotiated, and the Parties shall renegotiate in good faith such mutually acceptable new terms as may be required. In the event that such new terms are not renegotiated within ninety (90) days after such notice, the Dispute shall be referred to the Dispute Resolution procedure set forth in Section 12.
- 15.6 If any provision of this Agreement, or the application of such provision to either Party or circumstance, shall be held invalid, the remainder of the Agreement, or the application of any such provision to the Parties or circumstances other than those to which it is held invalid, shall not be affected thereby, provided that the Parties shall attempt to reformulate such invalid provision to give effect to such portions thereof as may be valid without defeating the intent of such provision.

16. **Waivers**

A failure or delay of either Party to enforce any of the provisions hereof, to exercise any option which is herein provided, or to require performance of any of the provisions hereof shall in no way be construed to be a waiver of such provisions or options, and each Party, notwithstanding such failure, shall have the right thereafter to insist upon the specific performance of any and all of the provisions of this Agreement.

17. **Governing Law**

This Agreement shall be governed by, and construed and enforced in accordance with, the laws of the State in which the services described herein have been provided or in which the dispute arose.

18. **Arm's Length Negotiations**

This Agreement was executed after arm's length negotiations between the undersigned Parties and reflects the conclusion of the undersigned that this Agreement is in the best interests of all Parties.

19. **Notices**

19.1 Every notice, consent, approval, or other communications required or contemplated by this Agreement shall be in writing and shall be delivered in person or given by postage prepaid mail, addressed to:

BellSouth Telecommunications, Inc.

CLEC Account Team
9th Floor
600 North 19th Street
Birmingham, Alabama 35203

and

General Attorney - COU
Suite 4300
675 W. Peachtree St.
Atlanta, GA 30375

Adelphia Business Solutions

Terry J. Romine
Director, Legal and Regulatory Affairs
One North Main Street
Coudersport, PA 16915

and

Tamar E. Finn
Swidler Berlin Shereff Friedman
3000 K Street, N.W.
Suite 300
Washington, DC 20007

or at such other address as the intended recipient previously shall have designated by written notice to the other Party.

19.2 Where specifically required, notices shall be by certified or registered mail. Unless otherwise provided in this Agreement, notice by mail shall be effective on the date it is officially recorded as delivered by return receipt or equivalent, and in the absence of such record of delivery, it shall be presumed to have been delivered the fifth day, or next business day after the fifth day, after it was deposited in the mails.

19.3 BellSouth shall provide Adelphia notice via Internet posting of retail price changes and of changes to the terms and conditions of retail services available for resale.

20. **Rule of Construction**

20.1.1 No rule of construction requiring interpretation against the drafting Party hereof shall apply in the interpretation of this Agreement.

21. **Headings of No Force or Effect**

The headings of Articles and Sections of this Agreement are for convenience of reference only, and shall in no way define, modify or restrict the meaning or interpretation of the terms or provisions of this Agreement.

22. **Multiple Counterparts**

This Agreement may be executed multiple counterparts, each of which shall be deemed an original, but all of which shall together constitute but one and the same document.

23. **Implementation of Agreement**

Where the Parties have not already established a prior course of dealing, within 60 days of the execution of this Agreement, the Parties will adopt a schedule for the implementation of the Agreement. The schedule shall state with specificity time frames for submission of including but not limited to, network design, interconnection points, collocation arrangement requests, pre-sales testing and full operational time frames for interconnection of the Parties' networks. The implementation template in Attachment 10 of this Agreement may be used by the Parties during the implementation process.

24. **Interference or Impairment.**

24.1 Notwithstanding any other provisions of this Attachment, neither Party shall use any product or service provided under this Agreement, any other service related thereto or used in combination therewith, or place or use any equipment or facilities in any manner that: 1) significantly degrades, interferes with or impairs service provided by the other Party or by any other entity or any person's use of its telecommunications service; 2) endangers or damages the equipment, facilities or other property of the other Party or of any other entity or person; 3) compromises

the privacy of any communications; or 4) creates an unreasonable risk of injury or death to any individual or to the public. If either Party reasonably determines that any equipment or facilities of the other Party violates the provisions of this paragraph, the complaining Party shall give written notice to the violating Party, which notice shall direct the violating Party to cure the violation within forty-eight (48) hours of receipt of such written notice or, at a minimum, to commence curative measures within 24 hours and to exercise reasonable diligence to complete such measures as soon as possible thereafter. Upon the violating Party's receipt of the notice, the Parties agree to consult immediately and, if necessary, to inspect the arrangement.

24.2 Except in the case of the deployment of an advanced service which significantly degrades the performance of other advanced services or traditional voice band services as described in Section 24.3 below, if the violating Party fails to take curative action within 48 hours, or if the violation is of a character which poses an immediate and substantial threat of damage to property, injury or death to any person, or in the event of any other impairment or interference with the complaining Party's service or network or the service or network of any other entity, then the complaining Party may take such reasonable action as it deems appropriate to correct the violation, including without limitation discontinuance of services to the violating Party and/or requesting expedited Commission resolution of the matter; provided, however, that neither Party shall have the right to interrupt electrical power to the other Party's equipment. The complaining Party will endeavor but is not required, to provide notice to the violating Party prior to taking such action. Upon the violating Party's correction of the interference or impairment, the complaining Party will promptly restore any discontinued services. During such period of suspension or interruption, there will be no compensation or credit allowance by the complaining Party to the violating Party, unless it is shown that the suspension or interruption in service by the complaining Party was unreasonable or unwarranted. The complaining Party shall not be liable to the violating Party for any damages arising from action taken under this Section 24, except to the extent that such action by the complaining Party constitutes gross negligence or willful misconduct.

24.3 For purposes of this Section 24, the term "significantly degrade" shall mean an action that noticeably impairs a service from a user's perspective. Notwithstanding anything to the contrary in Section 24.2 above, in the case of the deployment of an advanced service which significantly degrades the performance of other advanced services or traditional voice band services and where the violating Party fails to take curative action within 48 hours, the complaining Party will establish before the relevant state commission that the technology deployment is causing the significant degradation. Any claims of network harm presented to the violating Party or, if subsequently necessary, the relevant state Commission, must be supported with specific and verifiable information. Where the complaining Party demonstrates that a deployed technology is significantly degrading the performance of other advanced services or traditional voice band services, the

violating Party shall discontinue deployment of that technology and migrate its customers to technologies that will not significantly degrade the performance of other such services. Where the only degraded service itself is a known disturber, and the newly deployed technology satisfies at least one of the criteria for a presumption that is acceptable for deployment under section 47 C.F.R. 51.230, the degraded service shall not prevail against the newly-deployed technology.

25. Filing of Agreement

25.1 Upon execution of this Agreement it shall be filed with the appropriate state regulatory agency pursuant to the requirements of Section 252 of the Act. If the regulatory agency imposes any filing or public interest notice fees regarding the filing or approval of the Agreement, Adelphia shall be responsible for publishing the required notice and the publication and/or notice costs shall be split equally between BellSouth and Adelphia.

26. Guides

This Agreement contains reference to numerous Guides maintained by BellSouth, including, but not limited to, the BellSouth Local Interconnection and Facility Based Ordering Guide, BellSouth Resale Ordering Guide, BellSouth Products and Services Interval Guide, and the BellSouth Facility Based CLEC Activation Requirements Customer Guide (together, “Guides”). Where this Agreement references any BellSouth Guides, the Parties agree to adhere to such Guides, provided that these Guides do not affect the substantive rights and obligations of the Parties under this Agreement. In the event of a conflict between this Agreement and any Guides, this Agreement controls.

27. Entire Agreement

This Agreement and its Attachments, incorporated herein by this reference, sets forth the entire understanding and supersedes prior Agreements between the Parties relating to the subject matter contained herein and merges all prior discussions between them, and neither Party shall be bound by any definition, condition, provision, representation, warranty, covenant or promise other than as expressly stated in this Agreement or as is contemporaneously or subsequently set forth in writing and executed by a duly authorized officer or representative of the Party to be bound thereby.

This Agreement may include attachments with provisions for the following services:

Network Elements and Other Services
Local Interconnection
Resale
Collocation

If Adelphia has not already done so, Adelphia shall elect the following services by written request to its Account Manager.

The terms and conditions governing these services are set forth in Attachments 1 & 2.

- Optional Daily Usage File (ODUF)
- Line Information Database (LIDB) Storage
- Calling Name (CNAM)
- Enhanced Optional Daily Usage File (EODUF)
- Access Daily Usage File (ADUF)
- Centralized Message Distribution Service (CMDS)

IN WITNESS WHEREOF, the Parties have executed this Agreement the day and year above first written.

BellSouth Telecommunications, Inc.

Adelphia Business Solutions of Kentucky, Inc.

Signature

Signature

Name

Name

Title

Title

Date

Date

Definitions

Terms not defined herein shall have the meaning as set forth in the Act.

Affiliate is defined as a person that (directly or indirectly) owns or controls, is owned or controlled by, or is under common ownership or control with, another person. For purposes of this paragraph, the term “own” means to own an equity interest (or equivalent thereof) of more than 10 percent.

Centralized Message Distribution System is the Telcordia (formerly BellCore) administered national system, based in Kansas City, Missouri, used to exchange Exchange Message Interface (EMI) formatted data among host companies.

Commission is defined as the appropriate regulatory agency in each of BellSouth’s nine state region, Alabama, Florida, Georgia, Kentucky, Louisiana, Mississippi, North Carolina, South Carolina, and Tennessee.

Daily Usage File is the compilation of messages or copies of messages in standard Exchange Message Interface (EMI) format exchanged from BellSouth to a CLEC.

Exchange Message Interface is the nationally administered standard format for the exchange of data among the Exchange Carriers within the telecommunications industry.

Information Service means the offering of a capability for generating, acquiring, storing, transforming, processing, retrieving, utilizing, or making available information via telecommunications, and includes electronic publishing, but does not include any use of any such capability for the management, control, or operation of a telecommunications system or the management of a telecommunications service.

Intercompany Settlements (ICS) is the revenue associated with charges billed by a company other than the company in whose service area such charges were incurred. ICS on a national level includes third number and credit card calls and is administered by Telcordia (formerly BellCore)’s Calling Card and Third Number Settlement System (CATS). Included is traffic that originates in one Regional Bell Operating Company’s (RBOC) territory and bills in another RBOC’s territory.

Local Interconnection is defined as the delivery of local traffic to be terminated on each Party’s local network so that end users of either Party have the ability to reach end users of the other Party without the use of any access code or substantial delay in the processing of the call.

Local Traffic is defined as in Attachment 3.

Message Distribution is routing determination and subsequent delivery of message data from one company to another. Also included is the interface function with CMDS, where appropriate.

Multiple Exchange Carrier Access Billing (“MECAB”) means the document prepared by the Billing Committee of the Ordering and Billing Forum (“OBF”), which functions under the auspices of the Carrier Liaison Committee of the Alliance for Telecommunications Industry Solutions (“ATIS”) and by Telcordia (formerly BellCore) as Special Report SR-BDS-000983, containing the recommended guidelines for the billing of Exchange Service access provided by two or more LECs and/or CLECs or by one LEC in two or more states within a single LATA.

Network Element is defined to mean a facility or equipment used in the provision of a telecommunications service. Such term may include, but is not limited to, features, functions, and capabilities that are provided by means of such facility or equipment, including but not limited to, subscriber numbers, databases, signaling systems, and information sufficient for billing and collection or used in the transmission, routing, or other provision of a telecommunications service. BellSouth offers access to the Network Elements, unbundled loops; network interface device; sub-loop elements; local switching; transport; tandem switching; operator systems; signaling; access to call-related databases; dark fiber as set forth in Attachment 2 of this Agreement.

Non-Intercompany Settlement System (NICS) is the Telcordia (formerly BellCore) system that calculates non-intercompany settlements amounts due from one company to another within the same RBOC region. It includes credit card, third number and collect messages.

Percent of Interstate Usage (PIU) is defined as a factor to be applied to terminating access services minutes of use to obtain those minutes that should be rated as interstate access services minutes of use. The numerator includes all interstate “non-intermediary” minutes of use, including interstate minutes of use that are forwarded due to service provider number portability less any interstate minutes of use for Terminating Party Pays services, such as 800 Services. The denominator includes all “non-intermediary”, local, interstate, intrastate, toll and access minutes of use adjusted for service provider number portability less all minutes attributable to terminating Party pays services.

Percent Local Usage (PLU) is defined as a factor to be applied to intrastate terminating minutes of use. The numerator shall include all “non-intermediary” local minutes of use adjusted for those minutes of use that only apply local due to Service Provider Number Portability. The denominator is the total intrastate minutes of use including local, intrastate toll, and access, adjusted for Service Provider Number Portability less intrastate terminating Party pays minutes of use.

Revenue Accounting Office (RAO) Status Company is a local exchange company/alternate local exchange company that has been assigned a unique RAO code. Message data exchanged among RAO status companies is grouped (i.e. packed) according to From/To/Bill RAO combinations.

Service Control Points (“SCPs”) are databases that store information and have the ability to manipulate data required to offer particular services.

Signal Transfer Points (“STPs”) are signaling message switches that interconnect Signaling Links to route signaling messages between switches and databases. STPs enable the exchange of

Signaling System 7 (“SS7”) messages between switching elements, database elements and STPs. STPs provide access to various BellSouth and third party network elements such as local switching and databases.

Signaling links are dedicated transmission paths carrying signaling messages between carrier switches and signaling networks. Signal Link Transport is a set of two or four dedicated 56 kbps transmission paths between Adelphia designated Signaling Points of Interconnection that provide a diverse transmission path and cross connect to a BellSouth Signal Transfer Point.

Telecommunications means the transmission, between or among points specified by the user, of information of the user’s choosing, without change in the form or content of the information as sent and received.

Telecommunications Service means the offering of telecommunications for a fee directly to the public, or to such classes of users as to be effectively available directly to the public, regardless of the facilities used.

Telecommunications Act of 1996 (“Act”) means Public Law 104-104 of the United States Congress effective February 8, 1996. The Act amended the Communications Act of 1934 (47, U.S.C. Section 1 et. seq.).

Attachment 1

Resale

TABLE OF CONTENTS

1. Discount Rates.....3

2. Definition of Terms.....3

3. General Provisions.....4

4. Bellsouth’s Provision of Services To Adelphia8

5. Maintenance of Services.....9

6. Establishment of Service 10

7. Payment and Billing Arrangements..... 12

8. Discontinuance of Service 14

9. Line Information Database (LIDB) 15

10. RAO Hosting..... 15

11. Optional Daily Usage File (ODUF) 17

12. Enhanced Optional Daily Usage File (EODUF) 17

Exhibit A – Applicable Discounts/OSS Rates.....17

Exhibit B – Resale Restrictions.....20

Exhibit C – Line Information Database (LIDB) Storage Agreement.....22

Exhibit D – CMDS/ROA Hosting.....28

Exhibit E – Optional Daily Usage File ODUF).....33

Exhibit F – Enhanced Option Daily Usage File (EODUF).....37

Exhibit G – ODUF/EODUF/CMDS Rates.....Rate Table

RESALE

1. Discount Rates

The discount rates applied to Adelphia purchases of BellSouth Telecommunications Services for the purpose of resale shall be as set forth in Exhibit A. Such discount shall reflect the costs avoided by BellSouth when selling a service for wholesale purposes.

2. Definition of Terms

- 2.1 **COMPETITIVE LOCAL EXCHANGE COMPANY (CLEC)** means a telephone company certificated by the public service commissions of BellSouth's franchised area to provide local exchange service within BellSouth's franchised area.
- 2.2 **CUSTOMER OF RECORD** means the entity responsible for placing application for service; requesting additions, rearrangements, maintenance or discontinuance of service; payment in full of charges incurred such as non-recurring, monthly recurring, toll, directory assistance, etc.
- 2.3 **DEPOSIT** means assurance provided by a customer in the form of cash, surety bond or bank letter of credit to be held by BellSouth.
- 2.4 **END USER** means the ultimate user of the Telecommunications Services.
- 2.5 **END USER CUSTOMER LOCATION** means the physical location of the premises where an end user makes use of the Telecommunications Services.
- 2.6 **NEW SERVICES** means functions, features or capabilities that are not currently offered by BellSouth. This includes packaging of existing services or combining a new function, feature or capability with an existing service.
- 2.7 **RESALE** means an activity wherein a certificated CLEC, such as Adelphia subscribes to the Telecommunications Services of BellSouth and then reoffers those Telecommunications Services as set forth in this Agreement.

2.8 RESALE SERVICE AREA means the area, as defined in a public service commission approved certificate of operation, within which a CLEC, such as Adelphia, may offer resold local exchange Telecommunications Service.

3. General Provisions

3.1 Pursuant to the terms of this Attachment, Adelphia may resell any Telecommunications Service that BellSouth makes available at retail to customers who are not telecommunications carriers. Such services are available as set forth in BellSouth's General Subscriber Service Tariff and Private Line Service Tariff or as otherwise required by the Act and applicable FCC rules and orders. Such services are subject to the terms, and conditions specifically set forth herein.

3.2 All of the negotiated rates, terms and conditions set forth in this Attachment pertain to the resale of BellSouth's retail Telecommunications Services and other services specified in this Attachment. BellSouth shall make available Telecommunications Services for resale at the discount rates set forth in Exhibit A to this Agreement and subject to the exclusions and limitations set forth in Exhibit B to this Agreement. BellSouth does not however waive its rights to appeal or otherwise challenge any decision regarding resale that resulted in the discount rates contained in Exhibit A or the exclusions and limitations contained in Exhibit B. BellSouth reserves the right to pursue any and all legal and/or equitable remedies, including appeals of any decisions. If such appeals or challenges result in changes in the discount rates or exclusions and limitations, the parties agree that appropriate modifications to this Agreement will be made promptly to make its terms consistent with the outcome of the appeal.

3.3 Adelphia may purchase resale services from BellSouth for its own use in operating its business. The resale discount will apply to those services under the following conditions:

3.3.1 Adelphia must resell services to other end users.

3.3.2 Adelphia must order services through resale interfaces, i.e., the Local Carrier Service Center (LCSC) and/or appropriate Resale Account Teams pursuant to Section 3 of the General Terms and Conditions.

3.3.3 Adelphia cannot be a competitive local exchange telecommunications company for the single purpose of selling to itself.

3.4 The provision of services by BellSouth to Adelphia does not constitute a joint undertaking for the furnishing of any service.

- 3.5 Adelphia will be the customer of record for all services purchased from BellSouth. Except as specified herein, BellSouth will take orders from, bill and expect payment from Adelphia for all services.
- 3.6 Adelphia will be BellSouth's single point of contact for all services purchased pursuant to this Agreement. BellSouth shall have no contact with the end user except to the extent provided for herein. If an end user customer of Adelphia contacts BellSouth for customer care, BellSouth shall refer the customer directly to Adelphia's customer care personnel without making any effort to market to the customer in the context of that contact and without making any remarks as to the services provided by Adelphia. The Parties agree to provide one another with toll-free nationwide contact numbers for such purposes.
- 3.7 BellSouth will continue to bill the end user for any services that the end user specifies it wishes to receive directly from BellSouth.
- 3.8 BellSouth maintains the right to serve directly any end user within the service area of Adelphia. BellSouth will continue to directly market its own telecommunications products and services and in doing so may establish independent relationships with end users of Adelphia. Each Party shall comply with rules regarding the use of Customer Proprietary Network Information (as that term is described in the Act) as set forth in Section 222 of the Act and in effective and applicable FCC rules and orders.
- 3.9 Neither Party shall interfere with the right of any person or entity to obtain service directly from the other Party.
- 3.10 Current telephone numbers may normally be retained by the end user. However, telephone numbers are the property of BellSouth and are assigned to the service furnished. Adelphia has no property right to the telephone number or any other call number designation associated with services furnished by BellSouth, and no right to the continuance of service through any particular central office. BellSouth reserves the right to change such numbers, or the central office designation associated with such numbers, or both, whenever BellSouth deems it necessary to do so in the conduct of its business and in accordance with BellSouth practices and procedures on a nondiscriminatory basis.
- 3.11 For the purpose of the resale of BellSouth's Telecommunications Services by Adelphia, BellSouth will provide Adelphia with an on line access to telephone numbers for reservation on a first come first serve basis. Such reservations of telephone numbers, on a pre-ordering basis shall be for a period of ninety (90) days. Adelphia acknowledges that there may be instances where there is a shortage of telephone numbers in a particular Common Language Location Identifier Code (CLLIC) and in

such instances BellSouth may request that Adelphia cancel its reservations of numbers. Adelphia shall comply with such request, provided that BellSouth is subject to the same practices administered in a nondiscriminatory manner where such shortages of telephone numbers exist.

- 3.12 Further, upon Adelphia's request, and for the purpose of the resale of BellSouth's Telecommunications Services by Adelphia, BellSouth will reserve up to 100 telephone numbers per CLLIC, for Adelphia's sole use. Such telephone number reservations shall be valid for ninety (90) days from the reservation date. Adelphia acknowledges that there may be instances where there is a shortage of telephone numbers in a particular CLLIC and in such instances BellSouth shall use its best efforts to reserve for a ninety (90) day period a sufficient quantity of Adelphia's reasonable need in that particular CLLIC. BellSouth will apply any policies to address such shortages on a nondiscriminatory basis to itself, Adelphia, and other carriers (including, but not limited to, its own affiliates and subsidiaries).
- 3.13 Service is furnished subject to the condition that it will not be used for any unlawful purpose.
- 3.14 Service will be discontinued if any law enforcement agency advises that the service being used is in violation of the law.
- 3.15 BellSouth can refuse service when it has grounds to believe that service will be used in violation of the law.
- 3.16 BellSouth accepts no responsibility to any person for any unlawful act committed by Adelphia or its end users as part of providing service to Adelphia for purposes of resale or otherwise.
- 3.17 BellSouth will cooperate fully with law enforcement agencies with subpoenas and court orders for assistance with BellSouth's end users, pursuant to Section 7 of the General Terms and Conditions.
- 3.18 The characteristics and methods of operation of any circuits, facilities or equipment provided by any person or entity other than BellSouth shall not:
- 3.18.1 Interfere with or impair service over any facilities of BellSouth, its affiliates, or its connecting and concurring carriers involved in its service;
- 3.18.2 Cause damage to BellSouth's plant;
- 3.18.3 Impair the privacy of any communications; or

- 3.18.4 Create hazards to any BellSouth employees or the public.
- 3.19 BellSouth will only provision and maintain Telecommunications Services consistent with the terms and conditions of the tariff describing Telecommunications Services.
- 3.20 Facilities and/or equipment utilized by BellSouth to provide service to Adelphia remain the property of BellSouth.
- 3.21 White page directory listings will be provided in accordance with Section 5 of the General Terms and Conditions.
- 3.22 BellSouth provides electronic access to customer record information. Access is provided through the Local Exchange Navigation System (LENS) and the Telecommunications Access Gateway (TAG). Customer Record Information includes but is not limited to, customer specific information in CRIS and RSAG. In addition, Adelphia shall provide to BellSouth access to customer record information including electronic access where available. Otherwise, upon request by BellSouth Adelphia shall provide paper copies of customer record information within a reasonable period of time by BellSouth. Customer Record Information is equivalent to but not limited to the type of customer specific information contained in CRIS and RSAG. The Parties agree not to view, copy, or otherwise obtain access to the customer record information of any customer without that customer's permission, and further agrees that Adelphia and BellSouth will obtain access to customer record information only in strict compliance with applicable laws, rules, or regulations of the State in which the service is provided.
- 3.23 All costs incurred by BellSouth to develop and implement operational interfaces shall be recovered from Resellers who utilize the services. Charges for use of Operational Support Systems (OSS) shall be as set forth in Exhibit A of this Attachment.
- 3.24 Where available to BellSouth's end users, BellSouth shall provide the following Telecommunications Services at a discount to allow for voice mail services:
- Message Waiting Indicator ("MWI") stutter dialtone and message waiting light feature capabilities
 - Call Forward on Busy ("CF/B")
 - Call Forward Don't Answer ("CF/DA")

Further, BellSouth messaging services set forth in BellSouth's Messaging Service Information Package shall be made available for resale without the wholesale discount.

- 3.24.1 BellSouth shall provide branding for, or shall unbrand, voice mail services to Adelphia per the Bona Fide Request/New Business Request process as set forth in Section 6 of the General Terms and Conditions.
- 3.25 BellSouth's Inside Wire Maintenance Service Plans may be made available for resale at rates, terms and conditions as set forth by BellSouth and without the wholesale discount.
- 3.26 If Adelphia requires a special assembly Adelphia agrees to pay the reasonable and demonstrable costs incurred by BellSouth for providing the requested special assembly. A written statement summarizing the costs will be provided to Adelphia prior to providing the service and BellSouth will not provision the service until Adelphia has agreed to the costs. Such costs could include both recurring and non-recurring charges and the costs shall not exceed the costs that would be charged to an end user less any cost attributable to marketing, billing, collection or other costs that will be avoided by BellSouth in providing service to Adelphia. In the event Adelphia elects to resell an existing special assembly that BellSouth provides to an end user, BellSouth shall make available such special assembly at the rate charged to the end user less the applicable resale discount.
- 3.27 Recovery of charges associated with implementing Number Portability through monthly charges assessed to end users has been authorized by the FCC. This end user line charge will be billed to Resellers of BellSouth's Telecommunications Services and will be as filed in FCC No. 1. This charge is not discounted.
- 3.28 BellSouth shall provide 911/E911 for Adelphia customers in the same manner that it is provided to BellSouth customers. BellSouth shall provide and validate Adelphia customer information to the PSAP. BellSouth shall use its service order process to update and maintain, on the same schedule that it uses for its customers, the Adelphia customer service information in the ALI/DMS (Automatic Location Identification/Location Information) databases used to support 911/E911 services.
- 3.29 Pursuant to 47 CFR Section 51.617, BellSouth will bill Adelphia end users common line charges identical to the end user common line charges BellSouth bills its end users.
- 4. BellSouth's Provision of Services to Adelphia**
- 4.1 Adelphia agrees that its resale of BellSouth services shall be as follows:
- 4.1.1 The resale of Telecommunications Services shall be limited to users and uses conforming to the class of service restrictions.

- 4.1.2 Hotel and Hospital PBX services are the only Telecommunications Services available for resale to Hotel/Motel and Hospital end users, respectively. Similarly, Access Line Service for Customer Provided Coin Telephones is the only local service available for resale to Independent Payphone Provider (IPP) customers. Shared Tenant Service customers can only be sold those local exchange access services available in BellSouth's A23 Shared Tenant Service Tariff in the states of Florida, Georgia, North Carolina and South Carolina, and in A27 in the states of Alabama, Kentucky, Louisiana, Mississippi and Tennessee.
- 4.1.3 BellSouth reserves the right to periodically audit services purchased by Adelphia to establish authenticity of use. Such audit shall not occur more than once in a calendar year, during Adelphia's standard business hours and subject to confidentiality protection. Adelphia shall make any and all records and data available to BellSouth or BellSouth's auditors on a reasonable basis. BellSouth shall not make use of any of the information obtained during an audit pursuant to this section for any purposes other than to establish authenticity of use. BellSouth shall bear the cost of said audit.
- 4.2 Resold services can only be used in the same manner as specified in BellSouth's Tariffs. Resold services are subject to the same terms and conditions as are specified for such services when furnished to an individual end user of BellSouth in the appropriate section of BellSouth's Tariffs. Specific tariff features (e.g. a usage allowance per month), shall not be aggregated across multiple resold services.
- 4.3 Adelphia may resell services only within the specific resale service area as defined in its certificate.
- 4.4 Telephone numbers transmitted via any resold service feature are intended solely for the use of the end user of the feature. Resale of this information is prohibited.
- 5. Maintenance of Services**
- 5.1 Adelphia will adopt and adhere to the standards contained in the applicable CLEC Work Center Operational Understanding Agreement regarding maintenance and installation of service.
- 5.2 Services resold pursuant to this Attachment and BellSouth's General Subscriber Service Tariff and Private Line Service Tariff and facilities and equipment provided by BellSouth shall be maintained by BellSouth.
- 5.3 Adelphia or its end users may not rearrange, move, disconnect, remove or attempt to repair any facilities owned by BellSouth, other than by connection or disconnection to any interface means used, except with the written consent of BellSouth.

- 5.4 Adelphia accepts responsibility to notify BellSouth of situations that arise that may result in a service problem.
- 5.5 Adelphia will be BellSouth's single point of contact for all repair calls on behalf of Adelphia's end users. The parties agree to provide one another with toll-free contact numbers for such purposes.
- 5.6 Adelphia will contact the appropriate repair centers in accordance with procedures established by BellSouth.
- 5.7 For all repair requests, Adelphia accepts responsibility for adhering to BellSouth's prescreening guidelines prior to referring the trouble to BellSouth.
- 5.8 BellSouth will bill Adelphia for handling troubles that are found not to be in BellSouth's network pursuant to its standard time and material charges. The standard time and material charges will be no more than what BellSouth charges to its retail customers for the same services.
- 5.9 BellSouth reserves the right to contact Adelphia's end users, if deemed necessary, for maintenance purposes. In no event shall BellSouth make any effort to market to the customer in the context of that contact or make any remarks as to the services provided by Adelphia.

6. Establishment of Service

- 6.1 After receiving certification as a local exchange company from the appropriate regulatory agency, Adelphia will provide the appropriate BellSouth service center the necessary documentation to enable BellSouth to establish a master account for Adelphia's resold services. Such documentation shall include the Application for Master Account, proof of authority to provide Telecommunications Services, an Operating Company Number ("OCN") assigned by the National Exchange Carriers Association ("NECA") and a tax exemption certificate, if applicable. When necessary deposit requirements are met pursuant to Section 6.7, if applicable, BellSouth will begin taking orders for the resale of service.
- 6.2 Service orders will be in a standard format designated by BellSouth.
- 6.3 When notification is received from Adelphia that a current end user of BellSouth will subscribe to Adelphia's service, standard service order intervals for the appropriate class of service will apply.

- 6.4 BellSouth will not require end user confirmation prior to establishing service for Adelphia's end user customer. Adelphia must, however, be able to demonstrate end user authorization upon request.
- 6.5 Adelphia will be the single point of contact with BellSouth for all subsequent ordering activity resulting in additions or changes to resold services except that BellSouth will accept a request directly from the end user for conversion of the end user's service from Adelphia to BellSouth or will accept a request from another CLEC for conversion of the end user's service from Adelphia to the other LEC. BellSouth will notify Adelphia that such a request has been processed.
- 6.6 If BellSouth determines that an unauthorized change in local service to Adelphia has occurred, BellSouth will reestablish service with the appropriate local service provider and will assess Adelphia as the CLEC initiating the unauthorized change, the unauthorized change charge described in F.C.C. Tariff No. 1, Section 13 or applicable state tariff. Appropriate nonrecurring charges, as set forth in Section A4 of the General Subscriber Service Tariff, will also be assessed to Adelphia. These charges can be adjusted if Adelphia provides satisfactory proof of authorization.
- 6.7 In order to safeguard its interest, BellSouth reserves the right to secure the account with a suitable form of security deposit, unless satisfactory credit has already been established.
- 6.7.1 Such security deposit shall take the form of an irrevocable Letter of Credit or other forms of security acceptable to BellSouth. Any such security deposit may be held during the continuance of the service as security for the payment of any and all amounts accruing for the service.
- 6.7.2 If a security deposit is required, such security deposit shall be made prior to the inauguration of service.
- 6.7.3 Such security deposit may not exceed two months' estimated billing.
- 6.7.4 The fact that a security deposit has been made in no way relieves Adelphia from complying with BellSouth's regulations as to advance payments and the prompt payment of bills on presentation nor does it constitute a waiver or modification of the regular practices of BellSouth providing for the discontinuance of service for non-payment of any sums due BellSouth.
- 6.7.5 BellSouth reserves the right to increase the security deposit requirements when, in its reasonable judgment, material changes in Adelphia's financial circumstances so

warrant and/or gross monthly billing has increased significantly beyond the level initially used to determine the security deposit.

- 6.7.6 In the event that Adelphia defaults on its account, service to Adelphia will be terminated in accordance with Section 8 of this Attachment and any security deposits held will be applied to its account.
- 6.7.7 Interest on a security deposit shall accrue and be paid in accordance with the terms in the appropriate BellSouth tariff.

7. Payment And Billing Arrangements

- 7.1 Prior to submitting orders to BellSouth for local service, a master account must be established for Adelphia. Adelphia is required to provide the following before a master account is established: proof of PSC/PUC certification, the Application for Master Account, an Operating Company Number (“OCN”) assigned by the National Exchange Carriers Association (“NECA”) and a tax exemption certificate, if applicable.
- 7.2 BellSouth shall bill Adelphia on a current basis all applicable charges and credits.
- 7.3 Payment of all charges will be the responsibility of Adelphia. Adelphia shall make payment to BellSouth for all services billed. BellSouth is not responsible for payments not received by Adelphia from Adelphia's end user. BellSouth will not become involved in billing disputes that may arise between Adelphia and its end user. Payments made to BellSouth as payment on account will be credited to an accounts receivable master account and not to an end user's account.
- 7.4 BellSouth will render bills each month on established bill days for each of Adelphia's accounts.
- 7.5 BellSouth will bill Adelphia in advance charges for all services to be provided during the ensuing billing period except charges associated with service usage, which will be billed in arrears. Charges will be calculated on an individual end user account level, including, if applicable, any charge for usage or usage allowances. BellSouth will also bill Adelphia, and Adelphia will be responsible for and remit to BellSouth, all appropriate end user charges applicable to resold services including but not limited to 911 and E911 charges, telecommunications relay charges (TRS), and franchise fees.
- 7.6 The payment will be due by the next bill date (i.e., same date in the following month as the bill date) and is payable in immediately available funds. Payment is considered to have been made when received by BellSouth.

- 7.6.1 If the payment due date falls on a Sunday or on a Holiday which is observed on a Monday, the payment due date shall be the first non-Holiday day following such Sunday or Holiday. If the payment due date falls on a Saturday or on a Holiday which is observed on Tuesday, Wednesday, Thursday, or Friday, the payment due date shall be the last non-Holiday day preceding such Saturday or Holiday. If payment is not received by the payment due date, a late payment penalty, as set forth in section 7.8 following, shall apply.
- 7.6.2 If Adelphia requests multiple billing media or additional copies of bills, BellSouth will provide these at an appropriate charge to Adelphia.
- 7.6.3 Billing Disputes
- 7.6.3.1 Each Party agrees to notify the other Party upon the discovery of a billing dispute. In the event of a billing dispute, the Parties will endeavor to resolve the dispute within sixty (60) calendar days of the Bill Date on which such disputed charges appear. Resolution of the dispute is expected to occur at the first level of management resulting in a recommendation for settlement of the dispute and closure of a specific billing period. If the issues are not resolved within the allotted time frame, the following resolution procedure will begin:
- 7.6.3.2 If the dispute is not resolved within sixty (60) days of the Bill Date, the dispute will be escalated to the second level of management for each of the respective Parties for resolution. If the dispute is not resolved within ninety (90) days of the Bill Date, the dispute will be escalated to the third level of management for each of the respective Parties for resolution
- 7.6.3.3 If the dispute is not resolved within one hundred and twenty (120) days of the Bill Date, the dispute will be escalated to the fourth level of management for each of the respective Parties for resolution.
- 7.6.3.4 If a Party disputes a charge and does not pay such charge by the payment due date, such charges shall be subject to late payment charges as set forth in the Late Payment Charges provision of this Attachment. If a Party disputes charges and the dispute is resolved in favor of such Party, the other Party shall credit the bill of the disputing Party for the amount of the disputed charges along with any late payment charges assessed no later than the second Bill Date after the resolution of the dispute. Accordingly, if a Party disputes charges and the dispute is resolved in favor of the other Party, the disputing Party shall pay the other Party the amount of the disputed charges and any associated late payment charges assessed no later than the second bill payment due date after the resolution of the dispute. BellSouth shall only assess

interest on previously assessed late payment charges in a state where it has authority pursuant to its tariffs.

- 7.7 Upon proof of tax exempt certification from Adelphia, the total amount billed to Adelphia will not include any taxes due from the end user to reflect the tax exempt certification and local tax laws. Adelphia will be solely responsible for the computation, tracking, reporting, and payment of taxes applicable to Adelphia's end user.
- 7.8 If any portion of the payment is received by BellSouth after the payment due date as set forth preceding, or if any portion of the payment is received by BellSouth in funds that are not immediately available to BellSouth, then a late payment penalty shall be due to BellSouth. The late payment penalty shall be the portion of the payment not received by the payment due date times a late factor and will be applied on a per bill basis. The late factor shall be as set forth in Section A2 of the General Subscriber Services Tariff and Section B2 of the Private Line Service Tariff. Adelphia will be charged a fee for all returned checks as set forth in Section to A2 of the General Subscriber Services Tariff or in applicable state law.
- 7.9 Any switched access charges associated with interexchange carrier access to the resold local exchange lines will be billed by, and due to, BellSouth. No additional charges are to be assessed to Adelphia
- 7.10 BellSouth will not perform billing and collection services for Adelphia as a result of the execution of this Agreement. All requests for billing services should be referred to the appropriate entity or operational group within BellSouth.
- 7.11 In general, BellSouth will not become involved in disputes between Adelphia and Adelphia's end user customers over resold services. If a dispute does arise that cannot be settled without the involvement of BellSouth, Adelphia shall contact the designated Service Center for resolution. BellSouth will make every effort to assist in the resolution of the dispute and will work with Adelphia to resolve the matter in as timely a manner as possible. Adelphia may be required to submit documentation to substantiate the claim.
- 8. Discontinuance of Service**
- 8.1 The procedures for discontinuing service to an end user are as follows:
- 8.1.1 Where possible, BellSouth will deny service to Adelphia's end user on behalf of, and at the request of, Adelphia, putting Adelphia's end user in a "denied state." Upon

- restoration of the end user's service, restoral charges will apply and will be the responsibility of Adelphia.
- 8.1.2 At the request of Adelphia, BellSouth will disconnect a Adelphia end user customer.
 - 8.1.3 All requests by Adelphia for denial or disconnection of an end user for nonpayment must be in writing.
 - 8.1.4 Adelphia will be made solely responsible for notifying the end user of the proposed disconnection of the service.
 - 8.1.5 BellSouth will continue to process calls made to the Annoyance Call Center and will advise Adelphia when it is determined that annoyance calls are originated from one of their end user's locations. BellSouth shall be indemnified, defended and held harmless by Adelphia and/or the end user against any claim, loss or damage arising from providing this information to Adelphia. It is the responsibility of Adelphia to take the corrective action necessary with its end users who make annoying calls. Failure to do so will result in BellSouth's disconnecting the end user's service.
 - 8.1.5.1 BellSouth will process calls made by Adelphia, on behalf of Adelphia's end users, to the Annoyance Call Center. If an Adelphia end user contacts the Annoyance Call Center directly, BellSouth will refer the Adelphia end user to Adelphia. BellSouth will process Adelphia's calls in a non-discriminatory manner equal to the treatment afforded BellSouth end users and other CLECs.
 - 8.1.6 BellSouth may disconnect and reuse facilities when the facility is in a denied state and BellSouth has received an order to establish new service or transfer of service from an end user or an end user's CLEC at the same address served by the denied facility.
 - 8.2 The procedures for discontinuing service to Adelphia are as follows:
 - 8.2.1 BellSouth reserves the right to suspend or terminate service upon seven (7) days written notice in the event of prohibited, unlawful or improper use of the facilities or service, abuse of the facilities, or any other violation or noncompliance by Adelphia of the rules and regulations of BellSouth's Tariffs. If Adelphia should cure the alleged violation within the applicable notice time frame, BellSouth shall not suspend or terminate service.
 - 8.2.2 BellSouth reserves the right to refuse additional applications for service or to suspend or terminate service if payment of undisputed amounts is not received by the bill day in the month after the original bill day. If BellSouth exercises its right to refuse additional applications pursuant to this Section, BellSouth will provide prior written

notice to Adelphia that additional applications for service will be refused and that any pending orders for service will not be completed if payment of undisputed amounts is not received by the fifteenth day following the date of the notice. If BellSouth exercises its right to suspend or terminate service, BellSouth will give thirty days prior written notice to the person designated by Adelphia to receive notices of noncompliance, and discontinue the provision of existing services to Adelphia if Adelphia does not cure within the thirty (30) day timeframe. BellSouth may exercise its rights under this Section separately or simultaneously. For purposes of this Section 8, "undisputed amounts" shall mean amounts charged to Adelphia for which Adelphia has not submitted a good faith billing dispute in writing in accordance with Attachment 7 of this Agreement.

- 8.2.3 In the case of such discontinuance, all billed charges, as well as applicable termination charges shall become due.
- 8.2.4 If BellSouth does not discontinue the provision of the services involved on the date specified in the thirty days notice and Adelphia's noncompliance continues, nothing contained herein shall preclude BellSouth's right to discontinue the provision of the services to Adelphia without further notice.
- 8.2.5 If payment is not received or arrangements made for payment by the date given in the written notification, Adelphia's services will be discontinued. Upon discontinuance of service on a Adelphia's account, service to Adelphia's end users will be denied. BellSouth will also reestablish service at the request of the end user or Adelphia upon payment of the appropriate connection fee and subject to BellSouth's normal application procedures. Adelphia is solely responsible for notifying the end user of the proposed disconnection of the service.
- 8.2.6 If within fifteen days after an end user's service has been denied no contact has been made in reference to restoring service, the end user's service will be disconnected.

9. Line Information Database (LIDB)

- 9.1 BellSouth will store in its Line Information Database (LIDB) records relating to service only in the BellSouth region. The LIDB Storage Agreement is included in this Attachment as Exhibit C.
- 9.2 BellSouth will provide LIDB Storage upon written request to Adelphia Account Manager stating requested activation date.

10. RAO Hosting

10.1 The RAO Hosting Agreement is included in this Attachment as Exhibit D. Rates for BellSouth's Centralized Message Distribution System (CMDS) are as set forth in Exhibit H of this Attachment.

10.2 BellSouth will provide RAO Hosting upon written request to its Account Manager stating requested activation date.

11. Optional Daily Usage File (ODUF)

11.1 The Optional Daily Usage File (ODUF) Agreement with terms and conditions is included in this Attachment as Exhibit E. Rates for ODUF are as set forth in Exhibit H of this Attachment.

11.2 BellSouth will provide Optional Daily Usage File (ODUF) service upon written request to its Account Manager stating requested activation date.

12. Enhanced Optional Daily Usage File (EODUF)

12.1 The Enhanced Optional Daily Usage File (EODUF) service Agreement with terms and conditions is included in this Attachment as Exhibit F. Rates for EODUF are as set forth in Exhibit H of this Attachment.

12.2 BellSouth will provide Enhanced Optional Daily Usage File (EODUF) service upon written request to its Account Manager stating requested activation date.

EXHIBIT A
Page 1

APPLICABLE DISCOUNTS

The Telecommunications Services available for purchase by Adelphia for the purposes of resale to Adelphia end users shall be available at the following discount off of the retail rate. If Adelphia cancels an order for Telecommunications Services for the purpose of resale, BellSouth may charge Adelphia for cancellation costs in conjunction with the provisioning of that order in accordance with the applicable sections of the GSST and the PLST that set forth such cancellation charges.

| DISCOUNT* | | | |
|------------------|------------------|-----------------|----------------|
| STATE | RESIDENCE | BUSINESS | CSAs*** |
| ALABAMA | 16.3% | 16.3% | |
| FLORIDA | 21.83% | 16.81% | |
| GEORGIA | 20.3% | 17.3% | |
| KENTUCKY | 16.79% | 15.54% | |
| LOUISIANA | 20.72% | 20.72% | 9.05% |
| MISSISSIPPI | 15.75% | 15.75% | |
| NORTH CAROLINA | 21.5% | 17.6% | |
| SOUTH CAROLINA | 14.8% | 14.8% | 8.98% |
| TENNESSEE** | 16% | 16% | |

* When a CLEC provides Resale service in a cross boundary area (areas that are part of the local serving area of another state's exchange) the rates, regulations and discounts for the tariffing state will apply. Billing will be from the serving state.

** In Tennessee, if a CLEC provides its own operator services and directory services, the discount shall be 21.56%. CLEC must provide written notification to BellSouth within 30 days prior to providing its own operator services and directory services to qualify for the higher discount rate of 21.56%.

*** Unless noted in this column, the discount for Business will be the applicable discount rate for CSAs.

EXHIBIT A
Page 2

OPERATIONAL SUPPORT SYSTEMS (OSS) RATES

BellSouth has developed and made available the following mechanized systems by which Adelphia may submit LSRs electronically.

| | |
|------|-----------------------------------|
| LENS | Local Exchange Navigation System |
| EDI | Electronic Data Interchange |
| TAG | Telecommunications Access Gateway |

LSRs submitted by means of one of these interactive interfaces will incur an OSS electronic ordering charge as specified in the Table below. An individual LSR will be identified for billing purposes by its Purchase Order Number (PON). LSRs submitted by means other than one of these interactive interfaces (mail, fax, courier, etc.) will incur a manual order charge as specified in the table below:

| OPERATIONAL SUPPORT SYSTEMS (OSS) RATES | <u>Electronic</u> Per LSR received from the CLEC by one of the OSS interactive interfaces | <u>Manual</u> Per LSR received from the CLEC by means other than one of the OSS interactive interfaces |
|--|--|---|
| OSS LSR Charge | \$3.50 | \$19.99 |
| USOC | SOMEK | SOMAN |

Note: In addition to the OSS charges, applicable discounted service order and related discounted charges apply per the tariff.

Denial/Restoral OSS Charge

In the event Adelphia provides a list of customers to be denied and restored, rather than an LSR, each location on the list will require a separate PON and, therefore will be billed as one LSR per location.

Cancellation OSS Charge

Adelphia will incur an OSS charge for an accepted LSR that is later canceled by Adelphia.

Note: Supplements or clarifications to a previously billed LSR will not incur another OSS charge.

Threshold Billing Plan

EXHIBIT A

The Parties agree that Adelphia will incur the mechanized rate for all LSRs, both mechanized and manual, if the percentage of mechanized LSRs to total LSRs meets or exceeds the threshold percentages shown below:

| Year | Ratio: Mechanized/Total LSRs |
|------|------------------------------|
| 2000 | 80% |
| 2001 | 90% |

The threshold plan will be discontinued in 2002.

BellSouth will track the total LSR volume for each CLEC for each quarter. At the end of that time period, a Percent Electronic LSR calculation will be made for that quarter based on the LSR data tracked in the LCSC. If this percentage exceeds the threshold volume, all of that CLECs' future manual LSRs will be billed at the mechanized LSR rate. To allow time for obtaining and analyzing the data and updating the billing system, this billing change will take place on the first day of the second month following the end of the quarter (e.g. May 1 for 1Q, Aug 1 for 2Q, etc.). There will be no adjustments to the amount billed for previously billed LSRs.

**Exclusions and Limitations
On Services Available for Resale**

| Type of Service | AL | | FL | | GA | | KY | | LA | | MS | | NC | | SC | | TN | |
|--|--------|----------|--------|----------|--------|----------|--------|----------|--------|----------|--------|----------|--------|----------|--------|----------|--------|----------|
| | Resale | Discount | Resale | Discount | Resale | Discount | Resale | Discount | Resale | Discount | Resale | Discount | Resale | Discount | Resale | Discount | Resale | Discount |
| 1 Grandfathered Services (Note 1) | Yes | Yes | Yes | Yes | Yes | Yes | Yes | Yes | Yes | Yes | Yes | Yes | Yes | Yes | Yes | Yes | Yes | Yes |
| 2 Contract Service Arrangements | Yes | Yes | Yes | Yes | Yes | Yes | Yes | Yes | Yes | Yes | Yes | Yes | Yes | Yes | Yes | Yes | Yes | Yes |
| 3 Promotions - > 90 Days (Note 2) | Yes | Yes | Yes | Yes | Yes | Yes | Yes | Yes | Yes | Yes | Yes | Yes | Yes | Yes | Yes | Yes | Yes | Note 3 |
| 4 Promotions - < 90 Days (Note 2) | Yes | No | Yes | No | Yes | No | Yes | No | Yes | No | Yes | No | Yes | No | Yes | No | Yes | No |
| 5 Lifeline/Link Up Services | Yes | Yes | Yes | Yes | Yes | Yes | Note 4 | Note 4 | Yes | Yes | Yes | Yes | Yes | Yes | Yes | Yes | Yes | Yes |
| 6 911/E911 Services | Yes | Yes | Yes | Yes | Yes | Yes | Yes | Yes | No | No | Yes | Yes | Yes | Yes | Yes | Yes | Yes | Yes |
| 7 N11 Services | Yes | Yes | Yes | Yes | Yes | Yes | No | No | No | No | Yes | Yes | Yes | Yes | No | No | Yes | Yes |
| 8 AdWatch SM Svc (See Note 6) | Yes | Yes | Yes | Yes | Yes | Yes | Yes | Yes | Yes | Yes | Yes | Yes | Yes | Yes | Yes | Yes | Yes | Yes |
| 9 MemoryCall [®] Service | Yes | No | Yes | No | Yes | No | Yes | No | Yes | No | Yes | No | Yes | No | Yes | No | Yes | No |
| 10 Mobile Services | Yes | No | Yes | No | Yes | No | Yes | No | Yes | No | Yes | No | Yes | No | Yes | No | Yes | No |
| 11 Federal Subscriber Line Charges | Yes | No | Yes | No | Yes | No | Yes | No | Yes | No | Yes | No | Yes | No | Yes | No | Yes | No |

**Exclusions and Limitations
On Services Available for Resale**

| | | | | | | | | | | | | | | | | | | | |
|--------|---|-----|-----|-----|-----|-----|-----|-----|-----|-----|-----|-----|-----|-----|-----|-----|-----|-----|-----|
| 1 2 | Non-Recurring Charges | Yes | Yes | Yes | Yes | Yes | Yes | Yes | Yes | Yes | Yes | Yes | Yes | Yes | Yes | Yes | Yes | Yes | No |
| 1 3 | End User Line Charge – Number Portability | Yes | No | Yes | No | Yes | No | Yes | No | Yes | No | Yes | No | Yes | No | Yes | No | Yes | No |
| 1 4 | Public Telephone Access Service (PTAS) | Yes | Yes | Yes | Yes | Yes | Yes | Yes | Yes | Yes | Yes | Yes | Yes | Yes | Yes | Yes | No | Yes | Yes |

**Applicable
Notes:**

1. **Grandfathered services** can be resold only to existing subscribers of the grandfathered service.
2. Where available for resale, **promotions** will be made available only to end users who would have qualified for the promotion had it been provided by B
3. In Tennessee, long-term **promotions** (offered for more than ninety (90) days) may be obtained at one of the following rates:
 - (a) the stated tariff rate, less the wholesale discount;
 - (b) the promotional rate (the promotional rate offered by BellSouth will not be discounted further by the wholesale discount rate)
4. **Lifeline/Link Up** services may be offered only to those subscribers who meet the criteria that BellSouth currently applies to subscribers of these services as set forth in Sections A3 and A4 of the BellSouth General Subscriber Services Tariff.
5. Some of BellSouth's local exchange and toll Telecommunications Services are not available in certain central offices and areas.
6. AdWatchSM Service is tariffed as BellSouth[®] AIN Virtual Number Call Detail Service.

**LINE INFORMATION DATA BASE (LIDB)
STORAGE AGREEMENT**

I. SCOPE

- A. This Agreement sets forth the terms and conditions pursuant to which BellSouth agrees to store in its LIDB certain information at the request of Adelphia and pursuant to which BellSouth, its LIDB customers and Adelphia shall have access to such information. Adelphia understands that BellSouth provides access to information in its LIDB to various telecommunications service providers pursuant to applicable tariffs and agrees that information stored at the request of Adelphia, pursuant to this Agreement, shall be available to those telecommunications service providers. The terms and conditions contained in the attached Addendum(s) are hereby made a part of this Agreement as if fully incorporated herein.
- B. LIDB is accessed for the following purposes:
1. Billed Number Screening
 2. Calling Card Validation
 3. Fraud Control
- C. BellSouth will provide seven days per week, 24-hours per day, fraud monitoring on Calling Cards, bill-to-third and collect calls made to numbers in BellSouth's LIDB, provided that such information is included in the LIDB query. BellSouth will establish fraud alert thresholds and will notify Adelphia of fraud alerts so that Adelphia may take action it deems appropriate. Adelphia understands and agrees BellSouth will administer all data stored in the LIDB, including the data provided by Adelphia pursuant to this Agreement, in the same manner as BellSouth's data for BellSouth's end user customers. BellSouth shall not be responsible to Adelphia for any lost revenue which may result from BellSouth's administration of the LIDB pursuant to its established practices and procedures as they exist and as they may be changed by BellSouth in its sole discretion from time to time.

Adelphia understands that BellSouth currently has in effect numerous billing and collection agreements with various interexchange carriers and billing clearing houses. Adelphia further understands that these billing and collection customers of BellSouth query BellSouth's LIDB to determine whether to accept various billing options from end users. Additionally, Adelphia understands that presently BellSouth has no method to differentiate between BellSouth's own billing and line data in the LIDB and such

data which it includes in the LIDB on Adelphia's behalf pursuant to this Agreement. Therefore, until such time as BellSouth can and does implement in its LIDB and its supporting systems the means to differentiate Adelphia's data from BellSouth's data and the Parties to this Agreement execute appropriate amendments hereto, the following terms and conditions shall apply:

- (a) Adelphia agrees that it will accept responsibility for Telecommunications Services billed by BellSouth for its billing and collection customers for Adelphia's end user accounts which are resident in LIDB pursuant to this Agreement. Adelphia authorizes BellSouth to place such charges on Adelphia's bill from BellSouth and agrees that it shall pay all such charges. Charges for which Adelphia hereby takes responsibility include, but are not limited to, collect and third number calls.
- (b) Charges for such services shall appear on a separate BellSouth bill page identified with the name of the entity for which BellSouth is billing the charge.
- (c) Adelphia shall have the responsibility to render a billing statement to its end users for these charges, but Adelphia's obligation to pay BellSouth for the charges billed shall be independent of whether Adelphia is able or not to collect from Adelphia's end users.
- (d) BellSouth shall not become involved in any disputes between Adelphia and the entities for which BellSouth performs billing and collection. BellSouth will not issue adjustments for charges billed on behalf of an entity to Adelphia. It shall be the responsibility of Adelphia and the other entity to negotiate and arrange for any appropriate adjustments.

II. TERM

This Agreement will be effective as of _____, and will continue in effect for one year, and thereafter may be continued until terminated by either Party upon thirty (30) days written notice to the other Party.

III. FEES FOR SERVICE AND TAXES

- A. Adelphia will not be charged a fee for storage services provided by BellSouth to Adelphia, as described in Section I of this Agreement.
- B. Sales, use and all other taxes (excluding taxes on BellSouth's income) determined by BellSouth or any taxing authority to be due to any federal, state or local taxing

jurisdiction with respect to the provision of the service set forth herein will be paid by Adelphia. Adelphia shall have the right to have BellSouth contest with the imposing jurisdiction, at Adelphia's expense, any such taxes that Adelphia deems are improperly levied.

IV. INDEMNIFICATION

To the extent not prohibited by law, each Party will indemnify the other and hold the other harmless against any loss, cost, claim, injury, or liability relating to or arising out of negligence or willful misconduct by the indemnifying Party or its agents or contractors in connection with the indemnifying Party's provision of services, provided, however, that any indemnity for any loss, cost, claim, injury or liability arising out of or relating to errors or omissions in the provision of services under this Agreement shall be limited as otherwise specified in this Agreement. The indemnifying Party under this Section agrees to defend any suit brought against the other Party for any such loss, cost, claim, injury or liability. The indemnified Party agrees to notify the other Party promptly, in writing, of any written claims, lawsuits, or demands for which the other Party is responsible under this Section and to cooperate in every reasonable way to facilitate defense or settlement of claims. The indemnifying Party shall not be liable under this Section for settlement by the indemnified Party of any claim, lawsuit, or demand unless the defense of the claim, lawsuit, or demand has been tendered to it in writing and the indemnifying Party has unreasonably failed to assume such defense.

V. LIMITATION OF LIABILITY

Neither Party shall be liable to the other Party for any lost profits or revenues or for any indirect, incidental or consequential damages incurred by the other Party arising from this Agreement or the services performed or not performed hereunder, regardless of the cause of such loss or damage.

VI. MISCELLANEOUS

- A. It is understood and agreed to by the Parties that BellSouth may provide similar services to other companies.
- B. All terms, conditions and operations under this Agreement shall be performed in accordance with, and subject to, all applicable local, state or federal legal and regulatory tariffs, rulings, and other requirements of the federal courts, the U. S. Department of Justice and state and federal regulatory agencies. Nothing in this Agreement shall be construed to cause either Party to violate any such legal or

regulatory requirement and either Party's obligation to perform shall be subject to all such requirements.

- C. Adelphia agrees to submit to BellSouth all advertising, sales promotion, press releases, and other publicity matters relating to this Agreement wherein BellSouth's corporate or trade names, logos, trademarks or service marks or those of BellSouth's affiliated companies are mentioned or language from which the connection of said names or trademarks therewith may be inferred or implied; and Adelphia further agrees not to publish or use advertising, sales promotions, press releases, or publicity matters without BellSouth's prior written approval.
- D. This Agreement constitutes the entire Agreement between Adelphia and BellSouth which supersedes all prior Agreements or contracts, oral or written representations, statements, negotiations, understandings, proposals and undertakings with respect to the subject matter hereof.
- E. Except as expressly provided in this Agreement, if any part of this Agreement is held or construed to be invalid or unenforceable, the validity of any other Section of this Agreement shall remain in full force and effect to the extent permissible or appropriate in furtherance of the intent of this Agreement.
- F. Neither Party shall be held liable for any delay or failure in performance of any part of this Agreement for any cause beyond its control and without its fault or negligence, such as acts of God, acts of civil or military authority, government regulations, embargoes, epidemics, war, terrorist acts, riots, insurrections, fires, explosions, earthquakes, nuclear accidents, floods, strikes, power blackouts, volcanic action, other major environmental disturbances, unusually severe weather conditions, inability to secure products or services of other persons or transportation facilities, or acts or omissions of transportation common carriers.
- G. This Agreement shall be deemed to be a contract made under the laws of the State of Georgia, and the construction, interpretation and performance of this Agreement and all transactions hereunder shall be governed by the domestic law of such State.

**RESALE ADDENDUM
TO LINE INFORMATION DATA BASE (LIDB)
STORAGE AGREEMENT**

This is a Resale Addendum to the Line Information Data Base Storage Agreement dated _____, 2000, between BellSouth Telecommunications, Inc. (“BellSouth”), and Adelphia (“Adelphia”), effective the _____ day of _____, 2000.

I. GENERAL

This Addendum sets forth the terms and conditions for Adelphia’s provision of billing number information to BellSouth for inclusion in BellSouth’s LIDB. BellSouth will store in its LIDB the billing number information provided by Adelphia, and BellSouth will provide responses to on-line, call-by-call queries to this information for purposes specified in Section I.B. of the Agreement.

II. DEFINITIONS

- A. Billing number - a number used by BellSouth for the purpose of identifying an account liable for charges. This number may be a line or a special billing number.
- B. Line number - a ten-digit number assigned by BellSouth that identifies a telephone line associated with a resold local exchange service, or with a SPNP arrangement.
- C. Special billing number - a ten-digit number that identifies a billing account established by BellSouth in connection with a resold local exchange service or with a SPNP arrangement.
- D. Calling Card number - a billing number plus PIN number assigned by BellSouth.
- E. PIN number - a four digit security code assigned by BellSouth which is added to a billing number to compose a fourteen digit calling card number.
- F. Toll billing exception indicator - associated with a billing number to indicate that it is considered invalid for billing of collect calls or third number calls or both, by the Adelphia.
- G. Billed Number Screening - refers to the activity of determining whether a toll billing exception indicator is present for a particular billing number.

- H. Calling Card Validation - refers to the activity of determining whether a particular calling card number exists as stated or otherwise provided by a caller.
- I. Billing number information - information about billing number or Calling Card number as assigned by BellSouth and toll billing exception indicator provided to BellSouth by the Adelphia.

III. RESPONSIBILITIES OF PARTIES

- A. BellSouth will include billing number information associated with resold exchange lines or SPNP arrangements in its LIDB. The Adelphia will request any toll billing exceptions via the Local Service Request (LSR) form used to order resold exchange lines, or the SPNP service request form used to order SPNP arrangements.
- B. Under normal operating conditions, BellSouth shall include the billing number information in its LIDB upon completion of the service order establishing either the resold local exchange service or the SPNP arrangement, provided that BellSouth shall not be held responsible for any delay or failure in performance to the extent such delay or failure is caused by circumstances or conditions beyond BellSouth's reasonable control. BellSouth will store in its LIDB an unlimited volume of the working telephone numbers associated with either the resold local exchange lines or the SPNP arrangements. For resold local exchange lines or for SPNP arrangements, BellSouth will issue line-based calling cards only in the name of Adelphia. BellSouth will not issue line-based calling cards in the name of Adelphia's individual end users. In the event that Adelphia wants to include calling card numbers assigned by the Adelphia in the BellSouth LIDB, a separate agreement is required.
- C. BellSouth will provide responses to on-line, call-by-call queries to the stored information for the specific purposes listed in the next paragraph.
- D. BellSouth is authorized to use the billing number information to perform the following functions for authorized users on an on-line basis:
 - 1. Validate a 14 digit Calling Card number where the first 10 digits are a line number or special billing number assigned by BellSouth, and where the last four digits (PIN) are a security code assigned by BellSouth.
 - 2. Determine whether the Adelphia has identified the billing number as one which should not be billed for collect or third number calls, or both.

RAO Hosting

1. RAO Hosting, Calling Card and Third Number Settlement System (CATS) and Non-Intercompany Settlement System (NICS) services provided to Adelphia by BellSouth will be in accordance with the methods and practices regularly adopted and applied by BellSouth to its own operations during the term of this Agreement, including such revisions as may be made from time to time by BellSouth.
2. Adelphia shall furnish all relevant information required by BellSouth for the provision of RAO Hosting, CATS and NICS.
3. Applicable compensation amounts will be billed by BellSouth to Adelphia on a monthly basis in arrears. Amounts due from one Party to the other (excluding adjustments) are payable within thirty (30) days of receipt of the billing statement.
4. Adelphia must have its own unique RAO code. Requests for establishment of RAO status where BellSouth is the selected Centralized Message Distribution System (CMDS) interfacing host, require written notification from Adelphia to the BellSouth RAO Hosting coordinator at least eight (8) weeks prior to the proposed effective date. The proposed effective date will be mutually agreed upon between the Parties with consideration given to time necessary for the completion of required Telcordia (formerly BellCore) functions. BellSouth will request the assignment of an RAO code from its connecting contractor, currently Telcordia (formerly BellCore), on behalf of Adelphia and will coordinate all associated conversion activities.
5. BellSouth will receive messages from Adelphia that are to be processed by BellSouth, another LEC or CLEC in the BellSouth region or a LEC outside the BellSouth region.
6. BellSouth will perform invoice sequence checking, standard EMI format editing, and balancing of message data with the EMI trailer record counts on all data received from Adelphia.
7. All data received from Adelphia that is to be processed or billed by another LEC or CLEC within the BellSouth region will be distributed to that LEC or CLEC in accordance with the agreement(s) which may be in effect between BellSouth and the involved LEC or CLEC.
8. All data received from Adelphia that is to be placed on the CMDS network for distribution outside the BellSouth region will be handled in accordance with the agreement(s) which may be in effect between BellSouth and its connecting contractor (currently Telcordia (formerly BellCore)).

9. BellSouth will receive messages from the CMDS network that are destined to be processed by Adelphia and will forward them to Adelphia on a daily basis.
10. Transmission of message data between BellSouth and Adelphia will be via CONNECT:Direct.
11. All messages and related data exchanged between BellSouth and Adelphia will be formatted in accordance with accepted industry standards for EMI formatted records and packed between appropriate EMI header and trailer records, also in accordance with accepted industry standards.
12. Adelphia will ensure that the recorded message detail necessary to recreate files provided to BellSouth will be maintained for back-up purposes for a period of three (3) calendar months beyond the related message dates.
13. Should it become necessary for Adelphia to send data to BellSouth more than sixty (60) days past the message date(s), Adelphia will notify BellSouth in advance of the transmission of the data. If there will be impacts outside the BellSouth region, BellSouth will work with its connecting contractor and Adelphia to notify all affected Parties.
14. In the event that data to be exchanged between the two Parties should become lost or destroyed, both Parties will work together to determine the source of the problem. Once the cause of the problem has been jointly determined and the responsible Party (BellSouth or Adelphia) identified and agreed to, the company responsible for creating the data (BellSouth or Adelphia) will make every effort to have the affected data restored and retransmitted. If the data cannot be retrieved, the responsible Party will be liable to the other Party for any resulting lost revenue. Lost revenue may be a combination of revenues that could not be billed to the end users and associated access revenues. Both Parties will work together to estimate the revenue amount based upon historical data through a method mutually agreed upon. The resulting estimated revenue loss will be paid by the responsible Party to the other Party within three (3) calendar months of the date of problem resolution, or as mutually agreed upon by the Parties.
15. Should an error be detected by the EMI format edits performed by BellSouth on data received from Adelphia, the entire pack containing the affected data will not be processed by BellSouth. BellSouth will notify Adelphia of the error condition. Adelphia will correct the error(s) and will resend the entire pack to BellSouth for processing. In the event that an out-of-sequence condition occurs on subsequent

- packs, Adelphia will resend these packs to BellSouth after the pack containing the error has been successfully reprocessed by BellSouth.
16. In association with message distribution service, BellSouth will provide Adelphia with associated intercompany settlements reports (CATS and NICS) as appropriate.
17. In no case shall either Party be liable to the other for any direct or consequential damages incurred as a result of the obligations set out in this agreement.
18. RAO Compensation
- 18.1 Rates for message distribution service provided by BellSouth for Adelphia are as set forth in Exhibit A to this Attachment.
- 18.2 Rates for data transmission associated with message distribution service are as set forth in Exhibit A to this Attachment .
- 18.3 Data circuits (private line or dial-up) will be required between BellSouth and Adelphia for the purpose of data transmission. Where a dedicated line is required, Adelphia will be responsible for ordering the circuit, overseeing its installation and coordinating the installation with BellSouth. Adelphia will also be responsible for any charges associated with this line. Equipment required on the BellSouth end to attach the line to the mainframe computer and to transmit successfully ongoing will be negotiated on a case by case basis. Where a dial-up facility is required, dial circuits will be installed in the BellSouth data center by BellSouth and the associated charges assessed to Adelphia. Additionally, all message toll charges associated with the use of the dial circuit by Adelphia will be the responsibility of Adelphia. Associated equipment on the BellSouth end, including a modem, will be negotiated on a case by case basis between the Parties.
- 18.4 All equipment, including modems and software, that is required on the Adelphia end for the purpose of data transmission will be the responsibility of Adelphia.
19. Intercompany Settlements Messages
- 19.1 This Section addresses the settlement of revenues associated with traffic originated from or billed by Adelphia as a facilities based provider of local exchange Telecommunications Services outside the BellSouth region. Only traffic that originates in one Bell operating territory and bills in another Bell operating territory is included. Traffic that originates and bills within the same Bell operating territory will be settled on a local basis between Adelphia and the involved company(ies), unless

- that company is participating in NICS.
- 19.2 Both traffic that originates outside the BellSouth region by Adelphia and is billed within the BellSouth region, and traffic that originates within the BellSouth region and is billed outside the BellSouth region by Adelphia, is covered by this Agreement (CATS). Also covered is traffic that either is originated by or billed by Adelphia, involves a company other than Adelphia, qualifies for inclusion in the CATS settlement, and is not originated or billed within the BellSouth region (NICS).
- 19.3 Once Adelphia is operating within the BellSouth territory, revenues associated with calls originated and billed within the BellSouth region will be settled via Telcordia (formerly BellCore)'s, its successor or assign, NICS system.
- 19.4 BellSouth will receive the monthly NICS reports from Telcordia (formerly BellCore), its successor or assign, on behalf of Adelphia. BellSouth will distribute copies of these reports to Adelphia on a monthly basis.
- 19.5 BellSouth will receive the monthly Calling Card and Third Number Settlement System (CATS) reports from Telcordia (formerly BellCore), its successor or assign, on behalf of Adelphia. BellSouth will distribute copies of these reports to Adelphia on a monthly basis.
- 19.6 BellSouth will collect the revenue earned by Adelphia from the Bell operating company in whose territory the messages are billed (CATS), less a per message billing and collection fee of five cents (\$0.05), on behalf of Adelphia. BellSouth will remit the revenue billed by Adelphia to the Bell operating company in whose territory the messages originated, less a per message billing and collection fee of five cents (\$0.05), on behalf of Adelphia. These two amounts will be netted together by BellSouth and the resulting charge or credit issued to Adelphia via a monthly Carrier Access Billing System (CABS) miscellaneous bill.
- 19.7 BellSouth will collect the revenue earned by Adelphia within the BellSouth territory from another CLEC also within the BellSouth territory (NICS) where the messages are billed, less a per message billing and collection fee of five cents (\$0.05), on behalf of Adelphia. BellSouth will remit the revenue billed by Adelphia within the BellSouth region to the CLEC also within the BellSouth region, where the messages originated, less a per message billing and collection fee of five cents (\$0.05). These two amounts will be netted together by BellSouth and the resulting charge or credit issued to Adelphia via a monthly Carrier Access Billing System (CABS) miscellaneous bill.

BellSouth and Adelphia agree that monthly netted amounts of less than fifty dollars

(\$50.00) will not be settled.

Optional Daily Usage File

1. Upon written request from Adelphia, BellSouth will provide the Optional Daily Usage File (ODUF) service to Adelphia pursuant to the terms and conditions set forth in this section.
2. Adelphia shall furnish all relevant information required by BellSouth for the provision of the Optional Daily Usage File.
3. The Optional Daily Usage Feed will contain billable messages that were carried over the BellSouth Network and processed in the BellSouth Billing System, but billed to a Adelphia customer.

Charges for delivery of the Optional Daily Usage File will appear on Adelphia's monthly bills. The charges are as set forth in Exhibit A to this Attachment.

4. The Optional Daily Usage Feed will contain both rated and unrated messages. All messages will be in the standard Alliance for Telecommunications Industry Solutions (ATIS) EMI record format.
5. Messages that error in Adelphia's billing system will be the responsibility of Adelphia. If, however, Adelphia should encounter significant volumes of errored messages that prevent processing by Adelphia within its systems, BellSouth will work with the to determine the source of the errors and the appropriate resolution.
6. The following specifications shall apply to the Optional Daily Usage Feed.

6.1 **Usage To Be Transmitted**

6.1.1 The following messages recorded by BellSouth will be transmitted to Adelphia:

- Message recording for per use/per activation type services (examples: Three Way Calling, Verify, Interrupt, Call Return, ETC.)
- Measured billable Local
- Directory Assistance messages
- IntraLATA Toll
- WATS & 800 Service

- N11
- Information Service Provider Messages
- Operator Services Messages
- Operator Services Message Attempted Calls (UNE only)
- Credit/Cancel Records
- Usage for Voice Mail Message Service

6.1.2 Rated Incollects (originated in BellSouth and from other companies) can also be on Optional Daily Usage File. Rated Incollects will be intermingled with BellSouth recorded rated and unrated usage. Rated Incollects will not be packed separately.

6.1.3 BellSouth will perform duplicate record checks on records processed to Optional Daily Usage File. Any duplicate messages detected will be deleted and not sent to Adelphia.

6.1.4 In the event that Adelphia detects a duplicate on Optional Daily Usage File they receive from BellSouth, Adelphia will drop the duplicate message (Adelphia will not return the duplicate to BellSouth).

6.2 Physical File Characteristics

6.2.1 The Optional Daily Usage File will be distributed to Adelphia via an agreed medium with CONNECT:Direct being the preferred transport method. The Daily Usage Feed will be a variable block format (2476) with an LRECL of 2472. The data on the Daily Usage Feed will be in a non-compacted EMI format (175 byte format plus modules). It will be created on a daily basis (Monday through Friday except holidays). Details such as dataset name and delivery schedule will be addressed during negotiations of the distribution medium. There will be a maximum of one dataset per workday per OCN.

6.2.2 Data circuits (private line or dial-up) may be required between BellSouth and Adelphia for the purpose of data transmission. Where a dedicated line is required, Adelphia will be responsible for ordering the circuit, overseeing its installation and coordinating the installation with BellSouth. Adelphia will also be responsible for any charges associated with this line. Equipment required on the BellSouth end to attach the line

to the mainframe computer and to transmit successfully ongoing will be negotiated on a case by case basis. Where a dial-up facility is required, dial circuits will be installed in the BellSouth data center by BellSouth and the associated charges assessed to Adelphia. Additionally, all message toll charges associated with the use of the dial circuit by Adelphia will be the responsibility of Adelphia. Associated equipment on the BellSouth end, including a modem, will be negotiated on a case by case basis between the parties. All equipment, including modems and software, that is required on Adelphia end for the purpose of data transmission will be the responsibility of Adelphia.

6.3 Packing Specifications

6.3.1 A pack will contain a minimum of one message record or a maximum of 99,999 message records plus a pack header record and a pack trailer record. One transmission can contain a maximum of 99 packs and a minimum of one pack.

6.3.2 The OCN, From RAO, and Invoice Number will control the invoice sequencing. The From RAO will be used to identify to Adelphia which BellSouth RAO that is sending the message. BellSouth and Adelphia will use the invoice sequencing to control data exchange. BellSouth will be notified of sequence failures identified by Adelphia and resend the data as appropriate.

THE DATA WILL BE PACKED USING ATIS EMI RECORDS.

6.4 Pack Rejection

6.4.1 Adelphia will notify BellSouth within one business day of rejected packs (via the mutually agreed medium). Packs could be rejected because of pack sequencing discrepancies or a critical edit failure on the Pack Header or Pack Trailer records (i.e. out-of-balance condition on grand totals, invalid data populated). Standard ATIS EMI Error Codes will be used. Adelphia will not be required to return the actual rejected data to BellSouth. Rejected packs will be corrected and retransmitted to Adelphia by BellSouth.

6.5 Control Data

Adelphia will send one confirmation record per pack that is received from BellSouth. This confirmation record will indicate Adelphia received the pack and the acceptance or rejection of the pack. Pack Status Code(s) will be populated using standard ATIS EMI error codes for packs that were rejected by Adelphia for reasons stated in the above section.

6.6 Testing

- 6.6.1 Upon request from Adelphia, BellSouth shall send test files to Adelphia for the Optional Daily Usage File. The parties agree to review and discuss the file's content and/or format. For testing of usage results, BellSouth shall request that Adelphia set up a production (LIVE) file. The live test may consist of Adelphia's employees making test calls for the types of services Adelphia requests on the Optional Daily Usage File. These test calls are logged by Adelphia, and the logs are provided to BellSouth. These logs will be used to verify the files. Testing will be completed within 30 calendar days from the date on which the initial test file was sent.

Enhanced Optional Daily Usage File

1. Upon written request from Adelphia, BellSouth will provide the Enhanced Optional Daily Usage File (EODUF) service to Adelphia pursuant to the terms and conditions set forth in this section. EODUF will only be sent to existing ODUF subscribers who request the EODUF option.
2. The Adelphia shall furnish all relevant information required by BellSouth for the provision of the Enhanced Optional Daily Usage File.
3. The Enhanced Optional Daily Usage File (EODUF) will provide usage data for local calls originating from resold Flat Rate Business and Residential Lines.
4. Charges for delivery of the Enhanced Optional Daily Usage File will appear on Adelphia's monthly bills. The charges are as set forth in Exhibit A to this Attachment.
5. All messages will be in the standard Alliance for Telecommunications Industry Solutions (ATIS) EMI record format.
6. Messages that error in the billing system of Adelphia will be the responsibility of Adelphia. If, however, Adelphia should encounter significant volumes of errored messages that prevent processing by Adelphia within its systems, BellSouth will work with Adelphia to determine the source of the errors and the appropriate resolution.
7. The following specifications shall apply to the Optional Daily Usage Feed.
 - 7.1 **Usage To Be Transmitted**
 - 7.1.1 The following messages recorded by BellSouth will be transmitted to Adelphia:

Customer usage data for flat rated local call originating from Adelphia's end user lines (1FB or 1FR). The EODUF record for flat rate messages will include:

- Date of Call
- From Number
- To Number
- Connect Time
- Conversation Time
- Method of Recording
- From RAO
- Rate Class
- Message Type
- Billing Indicators
- Bill to Number

7.1.2 BellSouth will perform duplicate record checks on EODUF records processed to Optional Daily Usage File. Any duplicate messages detected will be deleted and not sent to Adelphia.

7.1.3 In the event that Adelphia detects a duplicate on Enhanced Optional Daily Usage File they receive from BellSouth, Adelphia will drop the duplicate message (Adelphia will not return the duplicate to BellSouth).

7.2 Physical File Characteristics

7.2.1 The Enhanced Optional Daily Usage Feed will be distributed to Adelphia over their existing Optional Daily Usage File (ODUF) feed. The EODUF messages will be intermingled among Adelphia's Optional Daily Usage File (ODUF) messages. The EODUF will be a variable block format (2476) with an LRECL of 2472. The data on the EODUF will be in a non-compacted EMI format (175 byte format plus modules). It will be created on a daily basis (Monday through Friday except holidays).

7.2.2 Data circuits (private line or dial-up) may be required between BellSouth and Adelphia for the purpose of data transmission. Where a dedicated line is required, Adelphia will be responsible for ordering the circuit, overseeing its installation and coordinating the installation with BellSouth. Adelphia will also be responsible for any charges associated with this line. Equipment required on the BellSouth end to attach the line to the mainframe computer and to transmit successfully ongoing will be negotiated on a case by case basis. Where a dial-up facility is required, dial circuits will be installed in the BellSouth data center by BellSouth and the associated charges assessed to Adelphia. Additionally, all message toll charges associated with the use of the dial circuit by Adelphia will be the responsibility of Adelphia. Associated equipment on the BellSouth end, including a modem, will be negotiated on a case by case basis between the parties. All equipment, including modems and software, that is required on Adelphia's end for the purpose of data transmission will be the responsibility of Adelphia.

7.3 Packing Specifications

7.3.1 A pack will contain a minimum of one message record or a maximum of 99,999 message records plus a pack header record and a pack trailer record. One transmission can contain a maximum of 99 packs and a minimum of one pack.

7.3.2 The Operating Company Number (OCN), From Revenue Accounting Office (RAO), and Invoice Number will control the invoice sequencing. The From RAO will be used to identify to Adelphia which BellSouth RAO that is sending the message. BellSouth and Adelphia will use the invoice sequencing to control data exchange. BellSouth will

be notified of sequence failures identified by Adelphia and resend the data as appropriate.

THE DATA WILL BE PACKED USING ATIS EMI RECORDS.

BELLSOUTH/ADELPHIA RATES
 ODUF/EODUF/CMDS

| DESCRIPTION | USOC | KY |
|--|------|-------------|
| ODUF/EODUF/CMDS | | |
| ODUF: Recording, per message | N/A | \$0.0008611 |
| ODUF: Message Processing, per message | N/A | \$0.0032357 |
| EODUF: Message Processing, per message | N/A | \$0.004 |
| CMDS: Message Processing, per message | N/A | \$0.004 |
| ODUF: Message Processing, per magnetic tape provisioned | N/A | \$55.68 |
| EODUF: Message Processing, per magnetic tape provisioned | N/A | \$47.30 |
| ODUF: Data Transmission (CONNECT:DIRECT), per message | N/A | \$0.0000365 |
| EODUF: Data Transmission (CONNECT:DIRECT), per message | N/A | \$0.0000364 |
| CMDS: Data Transmission (CONNECT:DIRECT), per message | N/A | \$0.001 |
| * Volume and term arrangements are also available. | | |

NOTES:

If no rate is identified in the contract, the rate for the specific service or function will be as set forth in applicable BellSouth tariff or as negotiated by the parties upon request by either party.

Attachment 2
Network Elements and Other Services

TABLE OF CONTENTS

1. INTRODUCTION..... 3

3. HIGH FREQUENCY SPECTRUM NETWORK ELEMENT..... 22

3. SWITCHING 28

5. UNBUNDLED NETWORK ELEMENT COMBINATIONS..... 39

5.6 PORT/LOOP COMBINATIONS..... 44

6. TRANSPORT AND DARK FIBER..... 46

7. BELLSOUTH SWA 8XX TOLL FREE DIALING TEN DIGIT SCREENING SERVICE..... 55

8. LINE INFORMATION DATABASE (LIDB)..... 57

9. SIGNALING 60

10. OPERATOR CALL PROCESSING, INWARD OPERATOR SERVICES AND DIRECTORY ASSISTANCE SERVICES 69

11. CALLING NAME (CNAM) DATABASE SERVICE..... 75

12. BASIC 911 AND E911 78

13. TRUE-UP 79

EXHIBIT C 90

LIDB Storage Agreement.....Exhibit

A

CNAM Database Services.....Exhibit

B

Rates.....Exhibit

D

ACCESS TO NETWORK ELEMENTS AND OTHER SERVICES

1. Introduction

- 1.1. This Attachment sets forth the unbundled network elements and combinations of unbundled network elements that BellSouth agrees to offer to Adelphia in accordance with its obligations under Section 251(c)(3) of the Act. The specific terms and conditions that apply to the unbundled network elements are described below in this Attachment 2. The price for each unbundled network element and combination of unbundled Network Elements is set forth in Exhibit A of this Agreement.
- 1.2. For purposes of this Agreement, “Network Element” is defined to mean a facility or equipment provided by BellSouth on an unbundled basis as is used by the CLEC in the provision of a telecommunications service. These unbundled network elements will be consistent with the requirements of 47 C.F.R. § 51.319. For purposes of this Agreement, combinations of Network Elements shall be referred to as “Combinations.”
 - 1.2.1. Except as otherwise required by law, BellSouth shall not impose limitation restrictions or requirements or request for the use of the network elements or combinations that would impair the ability of Adelphia to offer telecommunications service in the manner Adelphia intends.
 - 1.2.2. Except upon request by Adelphia, BellSouth shall not separate requested network elements that BellSouth currently combines.
 - 1.2.2.1. Unless otherwise ordered by an appropriate state or federal regulatory agency, currently combined Network Elements are defined as elements that are already combined within BellSouth's network to a given location.
- 1.3. BellSouth shall, upon request of Adelphia, and to the extent technically feasible, provide to Adelphia access to its network elements for the provision of Adelphia’s telecommunications service. If no rate is identified in the contract for a specific service or function that is identified in the Agreement, the rate for the specific service or function will be as negotiated by the Parties upon request by either Party.
- 1.4. Adelphia may purchase network elements and other services from BellSouth for the purpose of combining such network elements in any manner Adelphia chooses to provide telecommunication services to its intended users, including recreating existing BellSouth services. With the exception of the sub-loop elements which are located outside of the central office, BellSouth shall deliver the individual network elements

- purchased by Adelphia for combining to the designated Adelphia collocation space. The network elements shall be provided as set forth in this Attachment.
- 1.5. In addition to the combinations of Network Elements set forth in this Attachment, BellSouth will provide the following combined network components or elements for purchase by Adelphia. The rate of the following combined network components or elements is the sum of the individual element prices as set forth in this Attachment. Order Coordination as defined in Section 2 of Attachment 2 of this Agreement is available for each of these combinations, except as otherwise specified:
- SL2 loop and cross connect
 - Port and cross connect
 - Port and cross connect and common (shared) transport
 - Port and vertical features
 - SL2 Loop with loop concentration
 - Port and common (shared) transport
 - SL2 Loop and LNP
 - SL1 loop and cross connect (OC not available)
- 1.6. BellSouth shall comply with the requirements as set forth in the technical references within Attachment 2 to the extent that they are consistent with the greater of BellSouth's actual performance or applicable industry standards.
- 1.7. In the event that any effective legislative, regulatory, judicial or other legal action modifies or redefines the "Network Elements" in a manner which materially affects the terms of this Attachment or the Network Elements and/or prices set forth herein, either Party may, on thirty (30) days written notice, require renegotiation of such terms, and the Parties shall renegotiate in good faith such new terms in accordance with such legislative, regulatory, judicial or other legal action. In the event such new terms are not renegotiated within ninety (90) days after the notice for renegotiation, either Party may petition the Commission for resolution of the dispute between the Parties. Each Party reserves the right to seek judicial review of any Commission ruling concerning this Attachment.
- 1.8. Adelphia will adopt and adhere to the standards contained in the applicable CLEC Work Center Operational Understanding Agreement regarding maintenance and installation of service.
- 1.9. Standards for Network Elements
- 1.9.1 BellSouth shall comply with the requirements set forth in the technical references, as well as any performance or other requirements identified in this Agreement, to the extent that they are consistent with the greater of BellSouth's actual performance or applicable industry standards.

1.9.2 If one or more of the requirements set forth in this Agreement are in conflict, the parties shall mutually agree on which requirement shall apply. If the parties cannot reach agreement, the dispute resolution process set forth in Section 12 of the General Terms and Conditions of this Agreement, incorporated herein by this reference, shall apply.

2. Unbundled Loops, Integrated Digital Loop Carriers, Network Interfaces Device, Unbundled Loop Concentration (ULC) System, Sub loops and Dark Fiber

All of the negotiated rates, terms and conditions set forth in this Section pertain to the provision of unbundled loops.

2.1 Unbundled Loops

2.1.1 Definition

2.1.2 The local loop network element (“Loop(s)”) is defined as a transmission facility between a distribution frame (or its equivalent) in BellSouth’s central office and the loop demarcation point at an end-user customer premises, including inside wire owned by BellSouth. The local loop network element includes all features, functions, and capabilities of the transmission facilities, including dark fiber and attached electronics (except those used for the provision of advanced services, such as Digital Subscriber Line Access Multiplexers) and line conditioning. The loop shall include the use of all test access functionality, including without limitation, smart jacks, for both voice and data.

2.1.3 The provisioning of service to a CLEC will require cross-office cabling and cross-connections within the central office to connect the loop to a local switch or to other transmission equipment in collocation space. These cross-connects are a separate network component and are not considered a part of the loop.

2.1.4 BellSouth Order Coordination referenced in Attachment 2 includes two types: “Order Coordination” and “Order Coordination - Time Specific.”

2.1.5 “Order Coordination” (“OC”) refers to standard BellSouth service order coordination involving SL2 voice loops and all digital loops. Order coordination for physical conversions will be scheduled at BellSouth’s discretion during normal working hours (location time) on the committed due date, where BellSouth provides Adelphia prior notice of the due date.

2.1.6 “Order Coordination – Time Specific” (“OC-TS”) refers to service order coordination in which Adelphia requests a specific time for a service order conversion to take place. Loops on a single service order of 14 or more loops will be provisioned on a project basis. This is a chargeable option for any coordinated order and is billed in addition to the OC charge. Adelphia may specify a time between 9:00 a.m. and 4:00 p.m.

- (location time) Monday through Friday (excluding holidays). If Adelphia specifies a time outside this window, or selects a time or quantity of loops that requires BellSouth technicians to work outside normal work hours, overtime charges will apply in addition to the OC and OC-TS charges. Overtime charges will be applied according to actual costs based on type of force group required to perform the work, overtime hours worked and any special circumstances
- 2.1.7 Where facilities are available, as determined on a nondiscriminatory basis, BellSouth will install loops within a 5-7 business days interval beginning on the date BellSouth receives the order. For orders of 14 or more loops, the installation will be handled on a project basis and the intervals will be set by the BellSouth project manager for that order; provided that intervals set on a project basis shall be nondiscriminatory and BellSouth shall set such intervals at parity with the intervals BellSouth sets for itself, its affiliates, and other CLECs. Some loops require a Service Inquiry (SI) to determine if facilities are available prior to issuing the order. The interval for the SI process is separate from the installation interval. For expedite requests by Adelphia, expedite charges will apply for intervals less than 5 days. Charges associated with expedite requests are set forth in BellSouth's FCC #1 Tariff, Section 5.1.1 (such charges are currently \$295, subject to change upon modification of BellSouth's tariff). If Adelphia cancels an order for loops or any other Network Element, BellSouth shall be entitled to recover its reasonable and demonstrable costs incurred in providing that element or service up to the time of cancellation as set forth in BellSouth's FCC No. 1 Tariff, Section 5.4.
- 2.1.8 If Adelphia modifies an order after being sent a Firm Order Confirmation (FOC) from BellSouth, any reasonable and demonstrable costs incurred by BellSouth to accommodate the modification will be reimbursed by Adelphia.
- 2.1.9 BellSouth will offer Unbundled Voice Loops (UVL) on a nondiscriminatory basis in two different service levels - Service Level One (SL1) and Service Level Two (SL2).
- 2.1.10 SL1 loops will be non-designed, will not have test points, and will not come with any Order Coordination (OC) or engineering information/circuit make-up data. Upon issuance of an order in the service order system, SL1 loops will be activated on the due date in the same manner and time frames that BellSouth normally activates POTS-type loops for its customers. If Adelphia requests work to be done for SL1s that requires BellSouth technicians to work outside normal work hours (location time), overtime charges will be applied according to actual costs based on type of force group required to perform the work, overtime hours worked and any special circumstances.
- 2.1.11 SL2 loops shall have test points, with or without conditioning, will be designed with a design layout record provided to Adelphia, and will be provided with OC. The OC feature will allow Adelphia to coordinate the installation of the loop with the

- disconnect of an existing customer's service and/or number portability service. In these cases, BellSouth will perform the order conversion with standard order coordination at its discretion during normal work hours.
- 2.1.12 BellSouth will also offer Unbundled Digital Loops (UDL), such as DS1s and DS3s, on a nondiscriminatory basis. They will be designed, will be provisioned with test points (where appropriate), and will come standard with Order Coordination and a Design Layout Record (DLR).
- 2.1.13 As a chargeable option on all loops except UVL-SL1 and Unbundled Copper Loop (UCL), BellSouth will offer Order Coordination - Time Specific (OC-TS). This will allow Adelphia the ability to specify the time that the coordinated conversion takes place. The OC-TS charge for orders due on the same day at the same location will be applied on a per Local Service Request (LSR) basis.
- 2.1.14 Adelphia will be responsible for testing and isolating troubles on the loops. Once Adelphia has isolated a trouble to the BellSouth provided loop, Adelphia will issue a trouble report to BellSouth on the loop. BellSouth will take the actions necessary to repair the loop if a trouble actually exists. BellSouth will repair these loops in the same time frames that BellSouth repairs similarly situated loops to its customers.
- 2.1.15 If Adelphia reports a trouble on SL1 loops and no trouble actually exists, BellSouth will charge Adelphia as specified in BellSouth's FCC No. 1 Tariff, Section 13, for any dispatching and testing (both inside and outside the CO) required by BellSouth in order to confirm the loop's working status.
- 2.1.16 If Adelphia reports a trouble on SL2 loops and no trouble actually exists, BellSouth will charge Adelphia as specified in BellSouth's FCC No. 1 Tariff, Section 13, for any dispatching and testing, (outside the CO) required by BellSouth in order to confirm the loop's working status.
- 2.1.17 In addition to the UVLs and UDLs, BellSouth shall make available an UCL on a nondiscriminatory basis. The UCL will be a copper twisted pair loop that is unencumbered by any intervening equipment (e.g., filters, load coils, range extenders, digital loop carrier, or repeaters). The UCL will be offered in two versions - Short and Long. A short UCL (18 kft or less) will be provisioned according to Resistance Design parameters. The long UCL (beyond 18kft) will be used when a CLEC wants to condition copper loops longer than 18kft by removing load coils and other intervening equipment. BST will only ensure electrical continuity and balance relative to tip and ring on UCLs.
- 2.1.18 The UCL will be a designed circuit, with or without conditioning, provisioned with a test point and come standard with a DLR. OC will be offered as a chargeable option

on all UCL loops. Order Coordination – Time Specific (OC-TS) will not be offered on UCLs.

- 2.1.19 The UCL is a dry cooper loop and is not intended to support any particular telecommunications service. Adelphia may use the UCL loop for a variety of services, including xDSL (e.g., ADSL and HDSL) services, by attaching appropriate terminal equipment of Adelphia's choosing. Adelphia will determine the type of service that will be provided over the loop.
- 2.1.20 Because the UCL loop shall be an unbundled loop offering that is separate and distinct from BellSouth's ADSL and HDSL capable loop offerings, CLEC agrees that BellSouth's UCL loop will not be held to the service level and performance expectations that apply to its ADSL and HDSL unbundled loop offerings. BellSouth shall only be obligated to maintain copper continuity and provide balance relative to tip and ring on UCL loops.
- 2.1.21 The UCL loop shall be provided to CLEC in accordance with BellSouth's Technical Reference 73600.
- 2.1.22 Technical Requirements
- 2.1.22.1 To the extent available within BellSouth's Network at a particular location, BellSouth will offer loops capable of supporting telecommunications services such as: POTS, Centrex, basic rate ISDN, analog PBX, voice grade private line, ADSL, HDSL, and digital data (up to 64 kb/s). If a requested loop type is not available, then the CLEC can use the Special Construction process to request that BellSouth place facilities or otherwise modify facilities in order to meet Adelphia's request.
- 2.1.22.2 Adelphia will be responsible for providing BellSouth with a Service Profile Identifier (SPID) associated with a particular ISDN-capable loop and end user. With the SPID, BellSouth will be able to adequately test the circuit and ensure that it properly supports ISDN service.
- 2.1.22.3 The loop will support the transmission, signaling, performance and interface requirements of the services described in 2.1.3 above. It is recognized that the requirements of different services are different, and that a number of types or grades of loops are required to support these services. Services provided over the loop by Adelphia will be consistent with industry standards and BellSouth's TR73600.
- 2.1.22.4 Adelphia may utilize the unbundled loops to provide any telecommunication service it wishes. However, BellSouth will only provision, maintain and repair the loops to the standards that are consistent with the type of loop ordered. For example, if Adelphia orders an ISDN-capable loop but wants to use the loop for a service other than ISDN, BellSouth will only support that the loop is capable of providing ISDN service. For non-service specific loops (e.g. UCL, loops modified by Adelphia using the Special

- Construction process), BellSouth will only support that the loop has copper continuity and balanced tip-and-ring.
- 2.1.22.5 In some instances, Adelphia will require access to a copper twisted pair loop unfettered by any intervening equipment (e.g., filters, load coils, range extenders, etc.), so that Adelphia can use the loop for a variety of services by attaching appropriate terminal equipment at the ends. Adelphia will determine the type of service that will be provided over the loop. In some cases, Adelphia may be required to pay additional charges for the removal of certain types of equipment. If conditioning is required to make these loops available, BellSouth's Unbundled Loop Modification ("ULM") process will be utilized at the rates set forth in Exhibit D
- 2.1.22.6 In cases in which Adelphia has requested that BellSouth remove equipment from the BellSouth loop, and that loop no longer meets the appropriate technical specifications for the original loop type, BellSouth will no longer be expected to maintain and repair the loop to the standards specified for that loop type in the TR73600 and other standards referenced in this Agreement. Any loop modified beyond the appropriate technical specifications must be ordered as a UCL, and BellSouth will only support that these loops provide electrical continuity and balance relative to tip-and-ring.
- 2.1.22.7 The loop shall be provided to Adelphia in accordance with BellSouth's TR73600 Unbundled Local Loop Technical Specification and applicable industry standard technical references.

2.2 Unbundled Loop Modifications (Loop Conditioning)

- 2.2.1 Subject to applicable and effective FCC rules and orders, BellSouth shall condition loops, pursuant to the ULM process described in this Section 2.2 on a nondiscriminatory basis, as requested by Adelphia, whether or not BellSouth offers advanced services to the End User on that loop.
- 2.2.2 Loop conditioning is defined as the removal from the loop of any devices that may diminish the capability of the loop to deliver high-speed switched wireline telecommunications capability, including xDSL service. Such devices include, but are not limited to, bridge taps, low pass filters, and range extenders.
- 2.2.3 The Unbundled Loop Modifications (ULM) offering provides the following elements: (1) removal of equipment on loops less than 18kft, (2) removal of equipment of loops longer than 18 kft, (3) removal of bridged-taps on loops of any length.
- 2.2.4 BellSouth shall recover the cost of line conditioning requested by Adelphia through a recurring charge and/or nonrecurring charge(s) in accordance with the FCC's forward-looking pricing principles promulgated pursuant to section 252 (d) (1) of the Act and

in compliance with FCC Rule 52.507 (e). The prices for Loop Conditioning shall be as set forth in Exhibit D. The prices identified are interim in nature and shall apply only until such time as the Commission establishes prices for Loop Conditioning in any final order. At such time as a final order is issued, the Parties shall “true up” any amounts paid for Loop Conditioning back to the Effective Date of this Agreement, or such other date as ordered by the Commission, as if Adelphia had purchased all Loop Conditioning at the Commission-established rates starting on that Effective Date.

2.3. Integrated Digital Loop Carriers

2.3.1 Where BellSouth uses Integrated Digital Loop Carrier (IDLC) systems to provide the local loop and BellSouth has a suitable alternate facility available, BellSouth will make arrangements to permit Adelphia to order a contiguous local loop. To the extent it is technically feasible, these arrangements will provide Adelphia with the capability to serve end users at a level that is at parity with the level of service BellSouth provides its customers. If no alternate facility is available or if a subloop cannot be made available in the context of that order, BellSouth will utilize its Special Construction (SC) process to determine the additional costs required to provision the loop facilities. Adelphia will then have the option of paying the one-time SC rates to place the loop facilities or Adelphia may choose some other method of providing service to the end-user (e.g., Resale, private facilities, etc.); provided that the one-time SC rate shall not exceed the costs that a similarly situated BellSouth retail end user customer would pay when requesting a new line to that location.

2.4 Network Interface Device

2.4.1 Definition

The NID is defined as any means of interconnection of end-user customer premises wiring to BellSouth’s distribution plant, such as a cross-connect device used for that purpose. The NID is a single-line termination device or that portion of a multiple-line termination device required to terminate a single line or circuit at the premises. The NID features two independent chambers or divisions that separate the service provider’s network from the End User’s on-premises wiring. Each chamber or division contains the appropriate connection points or posts to which the service provider and the End User each make their connections. The NID provides a protective ground connection and is capable of terminating cables such as twisted pair cable.

2.4.2. BellSouth shall permit Adelphia to connect Adelphia’s loop facilities to on-premises wiring through the BellSouth NID or at any other technically feasible point.

2.4.3 Access to Network Interface Device (NID)

- 2.4.3.1. Due to the wide variety of NIDs utilized by BellSouth (based on subscriber size and environmental considerations), Adelphia may access the on-premises wiring by any of the following means: BellSouth shall allow Adelphia to connect its loops directly to BellSouth's multi-line residential NID enclosures that have additional space and are not used by BellSouth or any other telecommunications carriers to provide service to the premise. Adelphia agrees to install compatible protectors and test jacks and to maintain the protection system and equipment and to indemnify BellSouth pursuant to Section 8 of the General Terms and Conditions of this Agreement.
- 2.4.3.2. Where an adequate length of on-premises wiring is present and environmental conditions permit, either Party may remove the on-premises wiring from the other Party's NID and connect that wire to that Party's own NID; or
- 2.4.3.3. Enter the subscriber access chamber or "side" of "dual chamber" NID enclosures for the purpose of extending a connecterized or spliced jumper wire from the on-premises wiring through a suitable "punch-out" hole of such NID enclosures; or
- 2.4.3.4. Request BellSouth to make other rearrangements to the on-premises wiring terminations or terminal enclosure on a time and materials cost basis to be charged to the requesting Party (i.e., Adelphia, its agent, the building owner or the subscriber). Such charges will be billed to the requesting Party.
- 2.4.3.5. In no case shall either Party remove or disconnect the other Party's loop facilities from either Party's NIDs, enclosures or protectors unless: (1) the Commission has expressly permitted a LEC to remove or disconnect BellSouth's loop facilities from BellSouth's NID, and (2) the removing Party provides prior notice to the other Party. In such cases, it shall be the responsibility of the Party disconnecting loop facilities to leave undisturbed the existing form of electrical protection (if applicable), to maintain the physical integrity of the NID. The Party disconnecting the loop will hold the other Party harmless for any liability associated with removal of the loop from the other Party's NID and the disconnecting Party will assume full liability for its actions and for any adverse consequences that may result solely from its actions. Furthermore, it shall be the responsibility of the disconnecting Party to reconnect the disconnected loop to a nationally-recognized-testing-laboratory-listed station protector which has been grounded as per Article 800 of the National Electrical Code within the NID. If no spare station protector exists in the NID, the disconnected loop must be appropriately cleared, capped and stored. If the disconnecting Party does not wish to accept those responsibilities, other options exist in which BellSouth installs a NID as a chargeable option.
- 2.4.3.6. In no case shall either Party remove or disconnect ground wires from BellSouth's NIDs, enclosures, or protectors.
- 2.4.3.7. In no case shall either Party remove or disconnect NID modules, protectors, or terminals from BellSouth's NID enclosures.

2.4.3.8. Due to the wide variety of NID enclosures and outside plant environments BellSouth will work with Adelphia to develop specific procedures to establish the most effective means of implementing this Section, 2.4.3.

2.4.4 Technical Requirements

2.4.4.1 The NID shall provide an accessible point of interconnection and shall maintain a connection to ground.

2.4.4.2 The NID shall be capable of transferring electrical analog or digital signals between the subscriber's inside wiring and the Distribution Media and/or cross connect to Adelphia's NID, consistent with the NID's then-current function.

2.4.4.3 Where a BellSouth NID exists, it is provided in its "as is" condition. Adelphia may request BellSouth do additional work to the NID in accordance with Section 2.4.3.8.

2.4.4.4 When Adelphia deploys its own local loops with respect to multiple-line termination devices, Adelphia shall specify the quantity of NIDs connections that it requires within such device.

2.4.5 Interface Requirements

2.4.5.1 The NID shall be equal to or better than all of the requirements for NIDs set forth in the applicable industry standard technical references.

2.5 Unbundled Loop Concentration (ULC) System

2.5.1 BellSouth will provide to Adelphia Unbundled Loop Concentration (ULC) on a nondiscriminatory basis. Loop concentration systems in the central office concentrate the signals transmitted over local loops onto a digital loop carrier system. The concentration device is placed inside a BellSouth central office. BellSouth will offer ULC with a TR008 interface or a TR303 interface.

2.5.2 ULC will be offered in two sizes. System A will allow up to 96 BellSouth loops to be concentrated onto multiple DS1s. The high-speed connection from the concentrator will be at the electrical DS1 level and may connect to Adelphia at Adelphia's collocation site. System B will allow up to 192 BellSouth loops to be concentrated onto multiple DS1s. System A may be upgraded to a System B. A minimum of two DS1s is required for each system (i.e., System A requires two DS1s and System B would require an additional two DS1s or four in total). All DS1 interfaces will terminate to the CLEC's collocation space. ULC service is offered with or without concentration and with or without protection. A Line Interface element will be

required for each loop that is terminated onto the ULC system. Rates for ULC are as set forth in this Attachment.

2.6 Sub-loop Elements

2.6.1 Where facilities permit, as determined on a nondiscriminatory basis, and subject to applicable and effective FCC rules and orders, BellSouth shall offer nondiscriminatory access to its Unbundled Sub Loop (USL), Unbundled Subloop Concentration (USLC) System and Unbundled Network Terminating Wire (UNTW) elements. BellSouth shall provide non-discriminatory access, in accordance with 47 C.F.R. § 51.311 and section 251(c) (3) of the Act, to the subloop. On an unbundled basis and pursuant to the following terms and conditions and the rates approved by the Commission and set forth in this Attachment.

2.6.2 Subloop components include but are not limited to the following:

2.6.2.1 Unbundled Sub-Loop Distribution;

2.6.2.2 Unbundled Sub-Loop Concentration/Multiplexing Functionality; and

2.6.2.3 Unbundled Network Terminating Wire; and

2.6.2.4 Unbundled Sub-Loop Feeder.

2.6.3 Unbundled Sub-Loop (distribution facilities)

2.6.3.1 Definition

2.6.3.2 Subject to applicable and effective FCC rules and orders, the unbundled sub-loop distribution facility is dedicated transmission facility that BellSouth provides from a customer's point of demarcation to a BellSouth cross-connect device. The BellSouth cross-connect device may be located within a remote terminal (RT) or a stand-alone cross-box in the field or in the equipment room of a building. There are two offerings available for Unbundled Sub-Loops (USL):

2.6.3.3 Unbundled Sub-Loop Distribution (USL-D) will include the sub-loop facility from the cross-box in the field up to and including the point of demarcation.

2.6.3.4 BellSouth will also provide sub-loop interconnection to the intrabuilding network cable (INC) (riser cable). INC is the distribution facility inside a subscriber's building or between buildings on one customer's same premises (continuous property not separated by a public street or road). USL-INC (riser cable) will include the facility

from the cross-connect device in the building equipment room up to and including the point of demarcation.

2.6.4. Requirements for Unbundled Sub-Loop Distribution Facilities

2.6.4.1 Unbundled Sub-Loop distribution facilities were originally built as part of the entire voice grade loop from the BellSouth central office to the customer network interface. Therefore, the Unbundled Sub-Loop distribution facilities may have load coils, which are necessary for transmission of voice grade services. The Unbundled Sub-Loops will be provided in accordance with technical reference TR73600.

2.6.4.2 Unbundled Sub-Loop distribution facilities shall support functions associated with provisioning, maintenance and testing of the Unbundled Sub-Loop. In a scenario that involves connection at a BellSouth cross-box located in the field, Adelphia would be required to deliver a cable to the BellSouth remote terminal or cross-box to provide continuity to Adelphia's feeder facilities. This cable would be connected, by a BellSouth technician, to a cross-connect panel within the BellSouth RT/cross-box. Adelphia's cable pairs can then be connected to BellSouth's USL within the BellSouth cross-box by the BellSouth technician. In a scenario that requires connection in a building equipment room, BellSouth will install a cross connect panel on which access to the requested sub-loops will be connected. The CLEC's cable pairs can then be connected to the Unbundled Sub-Loop pairs on this cross-connect panel by the BellSouth technician.

2.6.4.3 BellSouth will provide Unbundled Sub-Loops where available and technically feasible. Through the firm order Service Inquiry (SI) process, BellSouth will determine if it is technically feasible to place the required facilities where Adelphia has requested access to Unbundled Sub-Loops. If existing capacity is sufficient to meet the CLEC demand (as capacity shall be determined on a nondiscriminatory, first-come, first-served basis), then BellSouth will perform the set-up work as described in the next section 2.6.4.4 . If any work must be done to modify existing BellSouth facilities or add new facilities (other than adding the cross-connect panel in a building equipment room as noted in 2.6.4.4) to accommodate Adelphia's request for Unbundled Sub-Loops, BellSouth will use its ULM or Special Construction (SC) process to determine the additional costs required to provision the Unbundled Sub-Loops; provided that the one-time SC rate shall not exceed the costs that a similarly situated BellSouth retail end user customer would pay when requesting a new sub-loop to that location. Adelphia will then have the option of paying the one-time SC charge to modify the facilities to meet Adelphia's request.

2.6.4.4 During the initial set-up in a BellSouth cross-connect box in the field, the BellSouth technician will perform the necessary work to splice the CLEC's cable into the cross-connect box. For the set-up inside a building equipment room, BellSouth will perform

the necessary work to install the cross-connect panel that will be used to provide access to the requested USLs. Once the set-up is complete, the CLEC requested sub-loop pairs would be provisioned through the service order process based on the submission of a LSR to the LCSC.

2.6.5 Interface Requirements

2.6.5.1 Unbundled Sub-Loop shall be equal to or better than each of the applicable requirements set forth in the applicable industry standard technical references.

2.6.6 **Unbundled Sub-Loop Concentration System (USLC)**

2.6.6.1 Where facilities permit (as determined on a nondiscriminatory basis) and where necessary to comply with an effective Commission order, BellSouth will provide Adelphia with the ability to concentrate its sub-loops onto multiple DS1s back to the BellSouth Central Office. The DS1s will then be terminated into Adelphia's collocation space. TR-008 and TR303 interface standards are available.

2.6.6.2 USLC, using the Lucent Series 5 equipment, will be offered in two different systems. System A will allow up to 96 of Adelphia's sub-loops to be concentrated onto multiple DS1s. System B will allow an additional 96 of Adelphia's sub-loops to be concentrated onto multiple DS1s. One System A may be supplemented with one System B and they both must be physically located in a single Series 5 dual channel bank. A minimum of two DS1s is required for each system (i.e., System A requires two DS1s and System B would require an additional two DS1s or four in total). The DS1 level facility that connects the remote terminal (RT) site with the serving wire center is known as a Feeder Interface. All DS1 Feeder Interfaces will terminate to the CLEC's collocation space within the SWC that serves the RT where the CLEC's sub-loops are connected. USLC service is offered with or without concentration and with or without a protection DS1.

2.6.6.3 In these scenarios Adelphia would be required to place a cross-box, RT, or other similar device and deliver a cable to the BellSouth remote terminal. This cable would be connected, by a BellSouth technician, to a cross-connect panel within the BellSouth RT/cross-box and would allow Adelphia's sub-loops to then be placed on the ULSC and transported to its collocation space at a DS1 level.

2.6.7 **Unbundled Network Terminating Wire (UNTW)**

2.6.7.1 BellSouth agrees to offer its Unbundled Network Terminating Wire (UNTW) to Adelphia on a nondiscriminatory basis and pursuant to the following terms and conditions at rates as set forth in this Attachment.

2.6.7.2 Definition

2.6.7.2.1 Subject to applicable and effective FCC rules and orders, UNTW is a dedicated transmission facility that BellSouth provides from the Wiring Closet /Garden Terminal (or other type of cross-connect point) at the point of termination of BellSouth's loop distribution facilities to the end user's point of demarcation.

2.6.7.3 Requirements

2.6.7.3.1 BellSouth will offer spare pairs that are available to an end user's premises to Adelphia. Available spare pairs are defined as pairs that are not being utilized by BellSouth or by a third party to provide an end user with working service at the time of Adelphia's request for UNTW. If no spare pairs are available and the end user is no longer using BellSouth's local service, BellSouth will relinquish the first pair to Adelphia. If after BellSouth has relinquished the first pair to Adelphia and the end user decides to change local service providers to BellSouth, Adelphia will relinquish the first pair back to BellSouth.

2.6.7.3.2 Notwithstanding the foregoing, should BellSouth subsequently require the use of additional pair(s) to provide for the activation of additional lines in an end users premises in response to a request from such end user, Adelphia agrees to surrender their spare pair(s) upon request by BellSouth.

2.6.7.3.3 If an end user of Adelphia desires to receive local exchange service from a service provider who is not a Party to this Agreement, and such third party service provider needs access to the BellSouth UNTW to provide local exchange service to the end user, then Adelphia agrees to surrender the requisite number of its inactive spare pair(s) of BellSouth's UNTW if no other spare pair is available and upon request by BellSouth.

2.6.7.3.4 If Adelphia has placed NTW at a location and an end user desires to receive local exchange service from BellSouth and BellSouth needs access to Adelphia's NTW to provide local exchange service to the end user, then upon request by BellSouth, Adelphia may, at its sole discretion, offer to lease the requisite number of its spare pair(s) to BellSouth at rates and terms to be negotiated by the Parties.

2.6.7.3.5 In new construction, where possible, both Parties may at their option and with the property owner's agreement install their own NTW. In existing construction, BellSouth shall not be required to install new or additional NTW beyond existing NTW to provision the services to the CLEC.

2.6.8 Technical Requirements

2.6.8.1 In these scenarios, BellSouth will connect the requested UNTW pairs to a single point of interconnection (SPOI) designed for CLEC access to BellSouth's NTW. The

SPOI will be installed either near BellSouth's garden terminal or wiring closet. Adelphia will be required to place a cross-box, terminal or other similar device and deliver a cable to this SPOI. Adelphia will then connect their cable to the cross-connect panel to access the requested UNTW pairs.

2.7 Dark Fiber Loops

2.7.1 Definition

Dark Fiber is an optical transmission facility without attached multiplexing, aggregation or other electronics that connects two points within BellSouth's network. Dark Fiber is unused strands of optical fiber. It may be strands of optical fiber existing in aerial or underground structure. No line terminating elements terminated to such strands to operationalize its transmission capabilities will be available. No regeneration or optical amplification will be included with this element.

2.7.2 Requirements

- 2.7.2.1 BellSouth shall make available Dark Fiber on a nondiscriminatory basis where it exists in BellSouth's network and where, as a result of future building or deployment, it becomes available. If BellSouth has pre-existing plans to make specific use of the fiber within a two –year planning period, there is no requirement to provide said fiber to Adelphia, provided that upon Adelphia's request, BellSouth shall provide written certification to Adelphia that BellSouth has plans to use such fiber and shall describe generally its plans to make such use, subject to Adelphia's representative signing a separate confidentiality agreement with respect to the disclosure of such plans.
- 2.7.2.2 If the requested dark fiber has any lightwave repeater equipment interspliced to it, BellSouth will remove such equipment at Adelphia's request subject to time and materials charges.
- 2.7.2.3 Adelphia may test the quality of the Dark Fiber to confirm its usability and performance specifications.
- 2.7.2.4 BellSouth shall use its best efforts to provide to Adelphia information regarding the location, availability and performance of Dark Fiber within ten (10) business days for a records based answer and twenty (20) business days for a field based answer, after receiving a request from Adelphia ("Request"). Within such time period, BellSouth shall send written confirmation of availability of the Dark Fiber ("Confirmation"). From the time of the Request to forty-five (45) days after Confirmation, BellSouth shall hold such requested Dark Fiber for Adelphia's use and may not allow any other party to use such media, including BellSouth.
- 2.7.2.5 BellSouth shall use its best efforts to make Dark Fiber available to Adelphia within thirty (30) business days after it receives written confirmation from Adelphia that the Dark Fiber previously deemed available by BellSouth is wanted for use by Adelphia.

This includes identification of appropriate connection points (e.g., Light Guide Interconnection (LGX) or splice points) to enable Adelphia to connect or splice Adelphia provided transmission media (e.g., optical fiber) or equipment to the Dark Fiber.

2.7.2.6 Dark Fiber shall meet the manufacturer's design specifications.

2.7.2.7 Adelphia may splice and test Dark Fiber obtained from BellSouth using Adelphia or Adelphia designated personnel. BellSouth shall provide appropriate interfaces to allow splicing and testing of Dark Fiber. BellSouth shall provide an excess cable length of 25 feet minimum (for fiber in underground conduit) to allow the uncoiled fiber to reach from the manhole to a splicing van.

2.8 Rates

The prices that Adelphia shall pay to BellSouth for Network Elements and Other Services are set forth in Exhibit D to this Attachment.

2.9 Operational Support Systems (OSS)

BellSouth has developed and made available the following mechanized systems by which Adelphia may submit LSRs electronically.

| | |
|------|-----------------------------------|
| LENS | Local Exchange Navigation System |
| EDI | Electronic Data Interchange |
| TAG | Telecommunications Access Gateway |

2.9.1 LSRs submitted by means of one of these interactive interfaces will incur an OSS electronic ordering charge as specified in the table below. An individual LSR will be identified for billing purposes by its Purchase Order Number (PON). LSRs submitted by means other than one of these interactive interfaces (mail, fax, courier, etc.) will incur a manual order charge as specified in the table below:

| OPERATIONAL SUPPORT SYSTEMS | AL, GA, LA, MS, NC, SC | FL, KY, TN |
|---|-------------------------------|-------------------|
| OSS LSR charge, per LSR received from the CLEC by one of the OSS interactive interfaces | \$3.50 | \$3.50 |
| | SOMECH | SOMECH |
| Incremental charge per LSR received from the CLEC by means other than one of the OSS interactive interfaces | See applicable rate element | \$19.99 |
| | | SOMAN |

2.9.2 Denial/Restoral OSS Charge

In the event Adelphia provides a list of customers to be denied and restored, rather than an LSR, each location on the list will require a separate PON and, therefore will be billed as one LSR per location.

2.9.3 Cancellation OSS Charge

Adelphia will incur an OSS charge for an accepted LSR that is later canceled by Adelphia.

Note: Supplements or clarifications to a previously billed LSR will not incur another OSS charge.

2.9.4 Network Elements and Other Services Manual Additive

2.9.4.1 The Commissions in some states have ordered per-element manual additive non-recurring charges (NRC) for Network Elements and Other Services ordered by means other than one of the interactive interfaces. These ordered Network Elements and Other Services manual additive NRCs will apply in these states, rather than the charge per LSR. The per-element charges are listed on the Rate Tables in Exhibit D.

2.10 **Preordering Loop Makeup (LMU)**

2.10.1 Description of Service

2.10.1.1 BellSouth shall make available to Adelphia with loop makeup (LMU) data for BellSouth's network facilities. This section addresses LMU as a preordering transaction, distinct from Adelphia ordering any other service(s). Loop Makeup Service Inquiries (LMUSI) for preordering loop makeup are likewise unique from other preordering functions with associated service inquiries (SI) as described in this Agreement.

2.10.1.2 BellSouth will provide Adelphia with loop makeup information consisting of the composition of the loop material (copper/fiber); the existence, location and type of equipment on the loop, including but not limited to digital loop carrier or other remote concentration devices, feeder/distribution interfaces, bridge taps, load coils, pair-gain devices; the loop length; and the wire gauge. The LMUSI may be utilized by Adelphia for the purpose of determining whether the loop requested is capable of supporting DSL service or other advanced data services. The determination shall be made solely by Adelphia and BellSouth shall not be liable in any way for the performance of the advanced data services provisioned over said loop.

2.10.1.3 BellSouth's LMU information is provided to Adelphia as it exists either in BellSouth's databases or in its hard copy facility records. BellSouth does not guarantee accuracy or reliability of the LMU information provided.

2.10.1.4 Targeted deployment of this service commences in the month of July, 2000.

2.10.2 Submitting Loop Makeup Service Inquiries

Adelphia will be able to obtain LMU information by submitting a LMUSI mechanically or manually. Mechanized LMUSIs should be submitted through BellSouth's Operational Support Systems interfaces. After obtaining the resulting loop data from the mechanized LMUSI process, if Adelphia determines that it needs further loop data information in order to make a determination of loop service capability, Adelphia may initiate a separate manual SI for a separate nonrecurring charge as set forth in Attachment 2, Section 1.3.

2.10.2.1 Manual LMUSIs shall be submitted on the preordering manual LMUSI form by means of fax or electronic-mail to BellSouth's Complex Resale Support Group (CRSG)/Account Team utilizing the Preordering Loop Makeup Service Inquiry form. The standard service interval for the return of a Loop Makeup Manual Service Inquiry is seven business days. This service interval is distinct from the interval applied to the subsequent service order. Manual LMUSIs are not subject to expedite requests.

2.10.3 LMUSI Types & Associated Charges

Adelphia may request LMU information by submitting LMUSIs in accordance with the rate elements listed below.

| LOOP MAKEUP SERVICE INQUIRIES | USOC | NRC - All States |
|---|-------------|-------------------------|
| MANUAL | | |
| Loop Makeup - Preordering Without Reservation, per working facility queried (Manual) | UMKLW | \$134 |
| Loop Makeup - Preordering Without Reservation, per spare facility queried (Manual) <i>Maximum number of spare facilities per manual LMUSI is (3).]</i> | UMKLW | \$134 |
| Loop Makeup - Preordering With Reservation, per spare facility queried (Manual) <i>Maximum number of spare facilities per manual LMUSI is (3).]</i> | UMKLP | \$140 |
| MECHANIZED | | |
| Loop Makeup - Preordering Without Reservation, per working facility queried (Mechanized) | TBD | \$1.08 |
| Loop Makeup - Preordering Without Reservation, per spare facility queried (Mechanized) <i>Maximum number of spare facilities per mechanized LMUSI is (10).]</i> | TBD | \$1.08 |
| Loop Makeup - Preordering With Reservation, per spare facility queried (Mechanized) <i>Maximum number of spare facilities per mechanized LMUSI is (10).]</i> | TBD | \$1.08 |

2.10.3.1 Adelphia will be assessed a nonrecurring charge for each facility queried as specified in the table above. Rates for all states are interim and subject to true-up pending

- approval of final rates by the respective State Commissions. True-ups will be retroactive to the effective date of this Agreement .
- 2.10.3.2 Adelphia may reserve facilities for up to four (4) days in connection with a LMUSI. Reserved facilities for which Adelphia does not plan to place a UNE local service request (LSR) should be cancelled by Adelphia. Should Adelphia wish to cancel a reservation on a spare facility, the cancellation will require a facility reservation number (RESID/FRN).
- 2.10.3.3 The reservation holding timeframe is a maximum of four days from the time that ellSouth's LMU information is returned to Adelphia for the facility queried. During this holding time and prior to Adelphia's placement of an LSR, the reserved facilities are rendered unavailable to other customers, whether for CLEC(s) or for BellSouth. Notwithstanding the foregoing, BellSouth does not guarantee that a reservation will result in the assurance of Adelphia's ability to order the exact facility reserved.
- 2.10.3.4 If Adelphia does not submit an LSR for a UNE service order on a reserved facility within the four-day reservation timeframe, the reservation of that spare facility will become invalid and the facility will be released.
- 2.10.3.5 Charges for preordering LMUSI are separate from any charges associated with ordering other services from BellSouth.
- 2.10.4 Ordering of Other UNE Services
- 2.10.4.1 Whenever Adelphia has reserved a facility through BellSouth's preordering LMU service, should Adelphia seek to place a subsequent UNE LSR on a reserved facility, Adelphia shall provide BellSouth the RESID/FRN of the single spare facility on the appropriate UNE LSR, Adelphia will be billed the appropriate rate element for the specific type UNE loop ordered by Adelphia as set forth in this Attachment. Adelphia will not be billed any additional Loop Makeup charges for the loop so ordered.
- 2.10.4.2 Should Adelphia choose to place a UNE LSR having previously submitted a request for preordering LMU *without a reservation*, Adelphia will be billed the appropriate rate element for the specific UNE loop ordered as well as additional Loop Makeup charges as set forth in this Attachment. Rates are provided in the UNE Rate Exhibits for Attachment 2.
- 2.10.4.3 Where Adelphia submits an LSR to order facilities reserved during the LMUSI process, BellSouth will use its best efforts to assign to Adelphia the facility reserved as indicated on the return of the LMU. Multi-facility reservations per single RESID/FRN as provided with the mechanized LMUSI process are less likely to result in the specific

- assignment requested by Adelphia. For those occasions when BellSouth's assignment system cannot assign the specific facility reserved by Adelphia during the LMU pre-ordering transaction, BellSouth will assign to Adelphia, subject to availability, a facility that meets the BellSouth technical standards of the BellSouth type loop as ordered by Adelphia. If the ordered loop type is not available, Adelphia may utilize the Unbundled Loop Modification process or the Special Construction process, as applicable, to obtain the loop type ordered.
- 2.10.4.4 BellSouth offers LMU information for the sole purpose of allowing Adelphia to determine whether, in Adelphia's judgment, BellSouth's loops will support the specific services that Adelphia wishes to provide over those loops. Adelphia may choose to use equipment that it deems will enable it to provide a certain type and level of service over a particular BellSouth loop; however, such configurations may not match BellSouth's or the industry's standards and specifications for the intended type and level of service. Accordingly, Adelphia shall be responsible for insuring that the specific loop type (ADSL, HDSL, or otherwise) ordered on the LSR matches the LMU of the facility requested. Adelphia bears full responsibility for being knowledgeable of BellSouth's technical standards and the specifications of BellSouth's loops. Adelphia bears full responsibility for making the appropriate ordering decisions of matching BellSouth loops with Adelphia's equipment for accomplishing Adelphia's end goal for the intended service it wishes to provide its end-user(s). Adelphia is fully responsible for any of its service configurations that may differ from BellSouth's technical standard for the loop type ordered.
- 3. High Frequency Spectrum Network Element**
- 3.1 General
- 3.1.1 BellSouth shall provide Adelphia access to the high frequency portion of the local loop as an unbundled network element ("High Frequency Spectrum") at the rates set forth in Section 4 herein. BellSouth shall provide Adelphia with the High Frequency Spectrum irrespective of whether BellSouth chooses to offer xDSL services on the loop.
- 3.1.2 The High Frequency Spectrum is defined as the frequency range above the voiceband on a copper loop facility carrying analog circuit-switched voiceband transmissions. Access to the High Frequency Spectrum is intended to allow Adelphia the ability to provide Digital Subscriber Line ("xDSL") data services to the end user on the same loop over which BellSouth provides voice services. The High Frequency Spectrum shall be available for any version of xDSL presumed acceptable for deployment pursuant to 47 C.F.R. Section 51.230, including, but not limited to, ADSL, RADSL, and any other xDSL technology that is presumed to be acceptable for deployment pursuant to FCC and Commission rules. BellSouth will continue to have access to the

- low frequency portion of the loop spectrum (from 300 Hertz to at least 3000 Hertz, and potentially up to 3400 Hertz, depending on equipment and facilities) for the purposes of providing voice service. Adelphia shall only use xDSL technology that is within the PSD mask parameters set forth in T1.413 or other applicable industry standards. Adelphia shall provision xDSL service on the High Frequency Spectrum in accordance with the applicable Technical Specifications and Standards.
- 3.1.3 The following loop requirements are necessary for Adelphia to be able to access the High Frequency Spectrum: an unconditioned, 2-wire copper loop. An unconditioned loop is a copper loop with no load coils, low-pass filters, range extenders, DAMLs, or similar devices and minimal bridged taps consistent with ANSI T1.413 and T1.601. The process of removing such devices is called “conditioning.” BellSouth shall charge and Adelphia shall pay as interim rates, the same rates that BellSouth charges for conditioning stand-alone loops (e.g., unbundled copper loops, ADSL loops, and HDSL loops) until permanent pricing for loop conditioning is established either by mutual agreement or by a state public utility commission. The interim costs for conditioning are subject to true up as provided in paragraph 4.0. BellSouth will condition loops to enable Adelphia to provide xDSL-based services on the same loops the incumbent is providing analog voice service, regardless of loop length. BellSouth is not required to condition a loop for shared-line xDSL if conditioning of that loop significantly degrades, from the perspective of an end user, BellSouth’s voice service. BellSouth shall charge, and Adelphia shall pay, for such conditioning the same rates BellSouth charges for conditioning stand-alone loops (e.g., unbundled copper loops, ADSL loops, and HDSL loops.) If Adelphia requests that BellSouth condition a loop longer than 18,000 ft. and such conditioning significantly degrades, from the perspective of an end user, the voice services on the loop, Adelphia shall pay for the loop to be restored to its original state.
- 3.1.4 Adelphia’s termination point is the point of termination for Adelphia on the toll main distributing frame in the central office (“Termination Point”). BellSouth will use jumpers to connect the Adelphia’s connecting block to the splitter. The splitter will route the High Frequency Spectrum on the circuit to the Adelphia’s xDSL equipment in the Adelphia’s collocation space.
- 3.1.5 Adelphia shall have access to the splitter for test purposes, irrespective of where the splitter is placed in the BellSouth premises. Should Adelphia desire to collocate its own splitter, the Parties will negotiate the terms and conditions associated with Adelphia’s provision of its own splitter.
- 3.2 Provisioning of High Frequency Spectrum and Splitter Space
- 3.2.1 BellSouth will provide Adelphia with access to the High Frequency Spectrum as follows:

- 3.2.1.1 BellSouth is unable to obtain a sufficient number of splitters for placement in all central offices requested by competitive local exchange carriers (“CLECs”) by June 6, 2000. Therefore, BellSouth, Adelphia and other CLECs have developed a process for allocating the initial orders of splitters. BellSouth will install all splitters ordered on or before April 26, 2000, in accordance with the schedule set forth in Attachment 1 of this Agreement. Once all splitters ordered by all CLECs on or before April 26, 2000, have been installed, BellSouth will install splitters within forty-two (42) calendar days of Adelphia’s submission of such order to the BellSouth Complex Resale Support Group; provided, however, that in the event BellSouth did not have reasonable notice that a particular central office was to have a splitter installed therein, the forty-two (42) day interval shall not apply. Collocation itself or an application for collocation will serve as reasonable notice. BellSouth and Adelphia will reevaluate this forty-two (42) day interval on or before August 1, 2000.
- 3.2.1.2 After June 6, 2000, once a splitter is installed on behalf of Adelphia in a central office, Adelphia shall be entitled to order the High Frequency Spectrum on lines served out of that central office.
- 3.2.1.3 BellSouth will select, purchase, install, and maintain a central office POTS splitter and provide Adelphia access to data ports on the splitter. In the event that BellSouth elects to use a brand of splitter other than Siecor, the Parties shall renegotiate the recurring and non-recurring rates associated with the splitter. In the event the Parties cannot agree upon such rates, the then current rates (final or interim) for the Siecor splitter shall be the interim rates for the new splitter. BellSouth will provide Adelphia with a carrier notification letter at least 30 days before such change and shall work collaboratively with Adelphia to select a mutually agreeable brand of splitter for use by BellSouth. Adelphia shall thereafter purchase ports on the splitter as set forth more fully below.
- 3.2.1.4 BellSouth will install the splitter in (i) a common area close to the Adelphia collocation area, if possible; or (ii) in a BellSouth relay rack as close to the Adelphia DS0 termination point as possible. For purposes of this section, a common area is defined as an area in the central office in which both Parties have access to a common test access point. BellSouth will cross-connect the splitter data ports to a specified Adelphia DS0 at such time that a Adelphia end user’s service is established.
- 3.2.1.5 The High Frequency Spectrum shall only be available on loops on which BellSouth is also providing, and continues to provide, analog voice service. In the event the end-user terminates its BellSouth provided voice service for any reason, and Adelphia desires to continue providing xDSL service on such loop, Adelphia shall be required to purchase the full stand-alone loop unbundled network element. In the event BellSouth disconnects the end-user’s voice service pursuant to its tariffs or applicable law, and

- Adelphia desires to continue providing xDSL service on such loop, Adelphia shall be permitted to continue using the line by purchasing the full stand-alone loop unbundled network element. BellSouth shall give Adelphia notice in a reasonable time prior to disconnect, which notice shall give Adelphia an adequate opportunity to notify BellSouth of its intent to purchase such loop. The Parties shall work collaboratively towards the mode of notification and the time periods for notice. In those cases in which BellSouth no longer provides voice service to the end user and Adelphia purchases the full stand-alone loop, Adelphia may elect the type of loop it will purchase. Adelphia will pay the appropriate recurring and non-recurring rates for such loop as set for in Attachment 2 of the Agreement. Adelphia acknowledges that a UVL loop may not remain xDSL compatible and Adelphia must purchase a UCL or UDL to ensure continued xDSL compatibility.
- 3.2.1.6 Adelphia and BellSouth shall continue to work together collaboratively to develop systems and processes for provisioning the High Frequency Spectrum in various real life scenarios. BellSouth and Adelphia agree that Adelphia is entitled to purchase the High Frequency Spectrum on a loop that is provisioned over fiber fed digital loop carrier. BellSouth will provide Adelphia with access to feeder subloops at rates and terms to be negotiated by the parties. BellSouth and Adelphia will work together to establish methods and procedures for providing Adelphia access to the High Frequency Spectrum over fiber fed digital loop carriers.
- 3.3 Only one competitive local exchange carrier shall be permitted access to the High Frequency Spectrum of any particular loop.
- 3.3.1 To order High Frequency Spectrum on a particular loop, Adelphia must have a DSLAM collocated in the central office that serves the end-user of such loop. BellSouth will work collaboratively with Adelphia to create a concurrent process that allows Adelphia to order splitters in central offices where Adelphia is in the process of obtaining collocation space and install such splitters before the end of Adelphia's collocation provisioning interval, provided that the interval is no less than the interval provided in paragraph 3.2.1.1.
- 3.3.2 BellSouth will devise a splitter order form that allows Adelphia to order splitter ports in increments of 24 or 96 ports.
- 3.3.2.1 BellSouth will provide Adelphia the Local Service Request ("LSR") format to be used when ordering the High Frequency Spectrum.
- 3.3.3 BellSouth will initially provide access to the High Frequency Spectrum within the following intervals: Beginning on June 6, 2000, BellSouth will return a Firm Order Confirmation ("FOC") in no more than two (2) business days after receipt of a valid,

error free LSR. BellSouth will provide Adelphia with access to the High Frequency Spectrum as follows:

- 3.3.3.1 For 1-5 lines at the same address within three (3) business days from the date BellSouth issues the FOC; 6-10 lines at same address within 5 business days from the date BellSouth issues the FOC; and more than 10 lines at the same address is to be negotiated, provided that intervals set on a project basis shall be nondiscriminatory and BellSouth shall set such intervals at parity with the intervals BellSouth sets for itself, its affiliates, and other CLECs. BellSouth and Adelphia will re-evaluate these intervals on or before August 1, 2000.
- 3.3.4 Adelphia will initially use BellSouth's existing pre-qualification functionality and order processes to pre-qualify line and order the High Frequency Spectrum. Adelphia and BellSouth will continue to work together to modify these functionalities and processes to better support provisioning the High Frequency Spectrum. BellSouth will use its best efforts to make available to Adelphia, by the fourth quarter of 2000, an electronic pre-ordering, ordering, provisioning, repair and maintenance and billing functionalities for the High Frequency Spectrum.
- 3.4 Maintenance and Repair
 - 3.4.1 Adelphia shall have access, for test, repair, and maintenance purposes, to any loop as to which it has access to the High Frequency Spectrum. Adelphia may access the loop at the point where the voice and data signals exit the central office splitter.
 - 3.4.2 BellSouth will be responsible for repairing voice services and the physical line between the network interface device at the customer premise and the Termination Point of demarcation in the central office. Adelphia will be responsible for repairing data services. Each Party will be responsible for maintaining its own equipment.
 - 3.4.3 If the problem encountered appears to impact primarily the xDSL service, the end user should call Adelphia. If the problem impacts primarily the voice service, the end user should call BellSouth. If both services are impaired, the recipient of the call should coordinate with the other service provider(s). Neither Party will initiate any marketing efforts with respect to the other Party's service nor make any remarks as to the services provided by the other Party.
 - 3.4.4 BellSouth and Adelphia will work together to diagnose and resolve any troubles reported by the end-user and to develop a process for repair of lines as to which Adelphia has access to the High Frequency Spectrum. The Parties will continue to work together to address customer initiated repair requests and other customer impacting maintenance issues to better support unbundling of High Frequency Spectrum.

- 3.4.5 The Parties will be responsible for testing and isolating troubles on its respective portion of the loop. Once a Party (“Reporting Party”) has isolated a trouble to the other Party’s (“Repairing Party”) portion of the loop, the Reporting Party will notify the Repairing Party that the trouble is on the Repairing Party’s portion of the loop. The Repairing Party will take the actions necessary to repair the loop if it determines a trouble exists in its portion of the loop.
- 3.4.6 If a trouble is reported on either Party’s portion of the loop and no trouble actually exists, the Repairing Party may charge the Reporting Party for any dispatching and testing (both inside and outside the central office) required by the Repairing Party in order to confirm the loop’s working status.
- 3.4.7 In the event Adelphia’s deployment of xDSL on the High Frequency Spectrum significantly degrades, from the perspective of the end user, the performance of other advanced services or of BellSouth’s voice service on the same loop, BellSouth shall notify Adelphia and allow twenty-four (24) hours to cure the trouble. If Adelphia fails to resolve the trouble, BellSouth may discontinue Adelphia’s access to the High Frequency Spectrum on such loop.
- 3.5 Pricing
- 3.5.1 BellSouth and Adelphia agree to the negotiated, interim rates for the High Frequency Spectrum set forth in Appendix D. All interim prices will be subject to true up based on either mutually agreed to permanent pricing or permanent pricing established in a line sharing cost proceeding conducted by the Commission. In the event interim prices are established by the Commission before permanent prices are established, either through arbitration or some other mechanism, the interim prices established in this Agreement will be changed to reflect the interim prices mandated by the Commission; however, no true up will be performed until mutually agreed to permanent prices are established or permanent prices are established by the Commission. Once a docket in a particular state in BellSouth’s region has been opened to determine permanent prices for the High Frequency Spectrum, BellSouth will provide cost studies for that state for the High Frequency Spectrum upon Adelphia’s written request, within 30 days or such other date as may be ordered by the Commission. All cost related information shall be provided pursuant to a proprietary, non-disclosure agreement.
- 3.5.2 BellSouth and Adelphia enter into this Agreement without waiving current or future relevant legal rights and without prejudicing any position BellSouth or Adelphia may take on relevant issues before state or federal regulatory or legislative bodies or courts of competent jurisdiction. This clause specifically contemplates but is not limited to: (a) the positions BellSouth or Adelphia may take in any cost docket related to the terms and conditions associated with access to the High Frequency Spectrum; and (b)

the positions that BellSouth or Adelphia might take before the FCC or any state public utility commission related to the terms and conditions under which BellSouth must provide Adelphia with access to the High Frequency Spectrum. The interim rates set forth herein were adopted as a result of a compromise between the parties and do not reflect either party's position as to final rates for access to the High Frequency Spectrum.

4. Switching

All of the negotiated rates, terms and conditions set forth in this Section pertain to the provision of local and tandem switching.

4.1 Local Switching

BellSouth shall provide non-discriminatory access to local circuit switching capability, and local tandem switching capability, on an unbundled basis, except as set forth below in Section 3.1.3 to Adelphia for the provision of a telecommunications service.

BellSouth shall provide non-discriminatory access to packet switching capability on an unbundled basis to Adelphia for the provision of a telecommunications service only in the limited circumstance described below in Section 3.5.

4.1.1 Except as otherwise provided herein, BellSouth shall not impose any restrictions on Adelphia regarding the use of Switching Capabilities purchased from BellSouth provided such use does not result in demonstrable harm to either the BellSouth network or personnel or the use of the BellSouth network by BellSouth or any other telecommunication carrier.

4.1.2 Local Circuit Switching Capability, including Tandem Switching Capability

4.1.2.1 Definition

Local Circuit Switching Capability is defined as: (A) line-side facilities, which include, but are not limited to, the connection between a loop termination at a main distribution frame and a switch line card; (B) trunk-side facilities, which include, but are not limited to, the connection between trunk termination at a trunk-side cross-connect panel and a switch trunk card; and (C) All features, functions, and capabilities of the switch, which include, but are not limited to: (1) the basic switching function of connecting lines to lines, line to trunks, trunks to lines, and trunks to trunks, as well as the same basic capabilities made available to BellSouth's customers, such as a telephone number, white page listings, and dial tone; and (2) all other features that the switch is capable of providing, including but not limited to customer calling, customer local area signaling service features, and Centrex, as well as any technically feasible customized routing functions provided by the switch; (D) switching provided by remote switching modules.

- 4.1.2.2 When utilizing BellSouth's local circuit switching capability, local traffic shall be defined as set forth in Part B of the General Terms and Conditions.
- 4.1.3 Notwithstanding BellSouth's general duty to unbundle local circuit switching, BellSouth shall not be required to unbundle local circuit switching for Adelphia when Adelphia serves end-users with four (4) or more voice-grade (DS-0) equivalents or lines in locations served by BellSouth's local circuit switches, which are in the following MSAs: Atlanta, GA; Miami, FL; Orlando, FL; Ft. Lauderdale, FL; Charlotte-Gastonia-Rock Hill, NC; Greensboro-Winston Salem-High Point, NC; Nashville, TN; and New Orleans, LA, and BellSouth has provided non-discriminatory cost based access to the Enhanced Extended Link (EEL) throughout Density Zone 1 as determined by NECA Tariff No. 4 as in effect on January 1, 1999.
- 4.1.4 In the event that Adelphia orders local circuit switching for a single end user account name at a single physical end user location with four (4) or more two (2) wire voice-grade loops from a BellSouth central office located in those MSAs listed in Section 3.1.3 above, BellSouth shall charge Adelphia a rate to be negotiated for use of the local circuit switching functionality for the affected facilities, or in the alternative, to charge Adelphia the local services resale rate for use of all Combinations used to provide the affected facilities to Adelphia.
- 4.1.5 A featureless port is one that has a line port, switching facilities, and an interoffice port. A featured port is a port that includes all features then capable or a number of then capable features specifically requested by Adelphia. Any features that are not currently then capable but are technically feasible through the switch can be requested through the BFR process.
- 4.1.6 BellSouth will provide to Adelphia customized routing of calls: (i) to a requested directory assistance services platform; (ii) to an operator services platform pursuant to Section 10 of Attachment 2; (iii) for Adelphia's PIC'ed toll traffic in a two (2) PIC environment to an alternative OS/DA platform designated by Adelphia. Adelphia customers may use the same dialing arrangements as BellSouth customers.
- 4.1.7 Remote Switching Module functionality is included in Switching Capability. The switching capabilities used will be based on the line side features they support.
- 4.1.8 Switching Capability will also be capable of routing local, intraLATA, interLATA, and calls to international customer's preferred carrier; call features (e.g. call forwarding) and Centrex capabilities.
- 4.1.9 Where required to do so in order to comply with an effective Commission order, BellSouth will provide to Adelphia purchasing local BellSouth switching or reselling BellSouth local exchange service under Attachment 1, selective routing of calls to a

requested directory assistance services platform or operator services platform. Adelphia customers may use the same dialing arrangements as BellSouth customers, but obtain a Adelphia branded service.

4.2 Technical Requirements

- 4.2.1 The requirements set forth in this Section apply to Local Switching, but not to the Data Switching function of Local Switching.
 - 4.2.1.1 Local Switching shall be equal to or better than the requirements for Local Switching set forth in the applicable industry standard technical references.
 - 4.2.1.2 When applicable, BellSouth shall route calls to the appropriate trunk or lines for call origination or termination.
 - 4.2.1.3 Subject to this section, BellSouth shall route calls on a per line or per screening class basis to (1) BellSouth platforms providing Network Elements or additional requirements (2) Operator Services platforms, (3) Directory Assistance platforms, and (4) Repair Centers. Any other routing requests by Adelphia will be made pursuant to the Bona Fide Request/ New Business Request Process as set forth in General Terms and Conditions.
 - 4.2.1.4 BellSouth shall provide unbranded recorded announcements and call progress tones to alert callers of call progress and disposition.
 - 4.2.1.5 BellSouth shall activate service for an Adelphia customer or network interconnection on any of the Local Switching interfaces. This includes provisioning changes to change a customer from BellSouth's services to Adelphia's services without loss of switch feature functionality as defined in this Agreement.
 - 4.2.1.6 BellSouth shall perform routine testing (e.g., Mechanized Loop Tests (MLT) and test calls such as 105, 107 and 108 type calls) and fault isolation on a mutually agreed upon schedule.
 - 4.2.1.7 BellSouth shall repair and restore any equipment or any other maintainable component that may adversely impact Local Switching.
 - 4.2.1.8 BellSouth shall control congestion points such as those caused by radio station call-ins, and network routing abnormalities. All traffic shall be restricted in a non-discriminatory manner.
 - 4.2.1.9 BellSouth shall perform manual call trace and permit customer originated call trace.
 - 4.2.1.10 Special Services provided by BellSouth will include the following:

- 4.2.1.10.1 Telephone Service Prioritization;
- 4.2.1.10.2 Related services for handicapped;
- 4.2.1.10.3 Soft dial tone where required by law; and
- 4.2.1.10.4 Any other service required by law.
- 4.2.1.11 BellSouth shall provide Switching Service Point (SSP) capabilities and signaling software to interconnect the signaling links destined to the Signaling Transfer Point Switch (STPS). These capabilities shall adhere to the technical specifications set forth in the applicable industry standard technical references.
- 4.2.1.12 BellSouth shall provide interfaces to adjuncts through Telcordia (formerly BellCore) standard interfaces. These adjuncts can include, but are not limited to, the Service Circuit Node and Automatic Call Distributors.
- 4.2.1.13 BellSouth shall provide performance data regarding a customer line, traffic characteristics or other measurable elements to Adelphia, upon a reasonable request from Adelphia. CLEC will pay BellSouth for all costs incurred to provide such performance data through the New Business Request process described in Attachment 12.
- 4.2.1.14 BellSouth shall offer Local Switching that provides feature offerings at parity to those provided by BellSouth to itself or any other Party. Such feature offerings shall include but are not limited to:
 - 4.2.1.14.1 Basic and primary rate ISDN;
 - 4.2.1.14.2 Residential features;
 - 4.2.1.14.3 Customer Local Area Signaling Services (CLASS/LASS);
 - 4.2.1.14.4 CENTREX (including equivalent administrative capabilities, such as customer accessible reconfiguration and detailed message recording); and
 - 4.2.1.14.5 Advanced intelligent network triggers supporting Adelphia and BellSouth service applications.
- 4.2.2 BellSouth shall offer to Adelphia all available AIN triggers in connection with its SMS/SCE offering which are supported by BellSouth for offering AIN-based services. These currently include, but may not be limited to:
 - 4.2.2.1 Off-Hook Immediate

- 4.2.2.2 Off-Hook Delay
- 4.2.2.3 Termination Attempt
- 4.2.2.4 6/10 Public Office Dialing Plan
- 4.2.2.5 Feature Code Dialing
- 4.2.2.6 Customer Dialing Plan
- 4.2.3 When the following triggers are supported by BellSouth, BellSouth will make these triggers available to Adelphia:
 - 4.2.3.1 Private EAMF Trunk
 - 4.2.3.2 Shared Interoffice Trunk (EAMF, SS7)
 - 4.2.3.3 N11
 - 4.2.3.4 Automatic Route Selection
- 4.2.4 Where capacity exists, BellSouth shall assign each Adelphia customer line the class of service designated by Adelphia (e.g., using line class codes or other switch specific provisioning methods), and shall route directory assistance calls from Adelphia customers to Adelphia directory assistance operators at Adelphia's option.
- 4.2.5 Where capacity exists, BellSouth shall assign each Adelphia customer line the class of services designated by Adelphia (e.g., using line class codes or other switch specific provisioning methods) and shall route operator calls from Adelphia customers to Adelphia operators at Adelphia's option. For example, BellSouth may translate 0- and 0+ intraLATA traffic, and route the call through appropriate trunks to an Adelphia Operator Services Position System (OSPS). Calls from Local Switching must pass the ANI-II digits unchanged.
- 4.2.6 Local Switching shall be offered in accordance with the technical specifications set forth in the applicable industry standard references.
- 4.2.7 Interface Requirements
 - 4.2.7.1 BellSouth shall provide all technically feasible and available interfaces to loops, including the following interfaces to loops:
 - 4.2.7.1.1 Standard Tip/Ring interface including loopstart or groundstart, on-hook signaling (e.g., for calling number, calling name and message waiting lamp);

- 4.2.7.1.2 Coin phone signaling;
- 4.2.7.1.3 Basic Rate Interface ISDN adhering to appropriate Telcordia (formerly BellCore) Technical Requirements;
- 4.2.7.1.4 Two-wire analog interface to PBX;
- 4.2.7.1.5 Four-wire analog interface to PBX;
- 4.2.7.1.6 Four-wire DS1 interface to PBX or customer provided equipment (e.g. computers and voice response systems);
- 4.2.7.1.7 Primary Rate ISDN to PBX adhering to ANSI standards Q.931, Q.932 and appropriate Telcordia (formerly BellCore) Technical Requirements;
- 4.2.7.1.8 Switched Fractional DS1 with capabilities to configure Nx64 channels (where N = 1 to 24); and
- 4.2.7.1.9 Loops adhering to Telcordia (formerly BellCore) TR-NWT-08 and TR-NWT-303 specifications to interconnect Digital Loop Carriers.
- 4.2.7.2 BellSouth shall provide access to the following but not limited to:
 - 4.2.7.2.1 SS7 Signaling Network or Multi-Frequency trunking if requested by Adelphia;
 - 4.2.7.2.2 Interface to Adelphia operator services systems or Operator Services through appropriate trunk interconnections for the system; and
 - 4.2.7.2.3 Interface to Adelphia Directory Assistance Services through the Adelphia switched network or to Directory Assistance Services through the appropriate trunk interconnections for the system; and 950 access or other Adelphia required access to interexchange carriers as requested through appropriate trunk interfaces.

4.3 Tandem Switching

4.3.1 Definition

Tandem Switching is the function that establishes a communications path between two switching offices through a third switching office (the Tandem switch).

4.3.2 Technical Requirements

- 4.3.2.1 Tandem Switching shall have the same capabilities or equivalent capabilities as those described in Bell Communications Research TR-TSY-000540 Issue 2R2, Tandem Supplement, 6/1/90. The requirements for Tandem Switching include, but are not limited to the following:

- 4.3.2.1.1 Tandem Switching shall provide signaling to establish a tandem connection;
- 4.3.2.1.2 Tandem Switching will provide screening as jointly agreed to by Adelphia and BellSouth;
- 4.3.2.1.3 Tandem Switching shall provide Advanced Intelligent Network triggers supporting AIN features where such routing is not available from the originating end office switch, to the extent such Tandem switch has such capability;
- 4.3.2.1.4 Tandem Switching shall provide access to Toll Free number portability database as designated by Adelphia;
- 4.3.2.1.5 Tandem Switching shall provide all trunk interconnections discussed under the “Network Interconnection” section (e.g., SS7, MF, DTMF, DialPulse, PRI-ISDN, DID, and CAMA-ANI (if appropriate for 911));
 - 4.3.2.1.5.1 Tandem Switching shall provide connectivity to PSAPs where 911 solutions are deployed and the tandem is used for 911; and
 - 4.3.2.1.5.2 Where appropriate, Tandem Switching shall provide connectivity to transit traffic to and from other carriers.
- 4.3.2.1.6 Tandem Switching shall accept connections (including the necessary signaling and trunking interconnections) between end offices, other tandems, IXCs, ICOs, CAPs and CLEC switches.
- 4.3.2.1.7 Tandem Switching shall provide local tandeming functionality between two end offices including two offices belonging to different CLEC's (e.g., between a CLEC end office and the end office of another CLEC).
- 4.3.2.1.8 Tandem Switching shall preserve CLASS/LASS features and Caller ID as traffic is processed.
- 4.3.2.1.9 Tandem Switching shall record billable events and send them to the area billing centers designated by Adelphia. Tandem Switching will provide recording of all billable events as jointly agreed to by Adelphia and BellSouth.
- 4.3.2.1.10 Upon a reasonable request from Adelphia, BellSouth shall perform routine testing and fault isolation on the underlying switch that is providing Tandem Switching and all its interconnections. The results and reports of the testing shall be made immediately available to Adelphia.
- 4.3.2.1.11 BellSouth shall maintain Adelphia's trunks and interconnections associated with Tandem Switching at least at parity to its own trunks and interconnections.

- 4.3.2.1.12 BellSouth shall control congestion points and network abnormalities. All traffic will be restricted in a non-discriminatory manner.
- 4.3.2.1.13 Selective Call Routing through the use of line class codes is not available through the use of tandem switching. Selective Call Routing through the use of line class codes is an end office capability only. Detailed primary and overflow routing plans for all interfaces available within BellSouth's switching network shall be mutually agreed to by Adelphia and BellSouth.
- 4.3.2.1.14 Tandem Switching shall process originating toll-free traffic received from Adelphia's local switch.
- 4.3.2.1.15 In support of AIN triggers and features, Tandem Switching shall provide SSP capabilities when these capabilities are not available from the Local Switching Network Element, to the extent such Tandem Switch has such capability.
- 4.3.2.2 Interface Requirements
- 4.3.2.2.1 Tandem Switching shall provide interconnection to the E911 PSAP where the underlying Tandem is acting as the E911 Tandem.
- 4.3.2.2.2 Tandem Switching shall interconnect, with direct trunks, to all carriers with which BellSouth interconnects.
- 4.3.2.2.3 BellSouth shall provide all signaling necessary to provide Tandem Switching with no loss of feature functionality.
- 4.3.2.2.4 Tandem Switching shall interconnect with Adelphia's switch, using two-way trunks, for traffic that is transiting via BellSouth's network to interLATA or intraLATA carriers. At Adelphia's request, Tandem Switching shall record and keep records of traffic for billing.
- 4.3.2.2.5 Tandem Switching shall provide an alternate final routing pattern for Adelphia's traffic overflowing from direct end office high usage trunk groups.
- 4.3.2.2.6 Tandem Switching shall be equal or better than the requirements for Tandem Switching set forth in the applicable technical references.
- 4.4 **AIN Selective Carrier Routing for Operator Services, Directory Assistance and Repair Centers**
- 4.4.1 BellSouth will provide AIN Selective Carrier Routing at the request of Adelphia. AIN Selective Carrier Routing will provide Adelphia with the capability of routing operator

- calls, 0+ and 0- and 0+ NPA (LNPA) 555-1212 directory assistance, 1+411 directory assistance and 611 repair center calls to pre-selected destinations.
- 4.4.2 Adelphia shall order AIN Selective Carrier Routing through its Account Team. AIN Selective Carrier Routing must first be established regionally and then on a per central office, per state basis.
- 4.4.3 AIN Selective Carrier Routing is not available in DMS 10 switches.
- 4.4.4 Where AIN Selective Carrier Routing is utilized by Adelphia, the routing of Adelphia's end user calls shall be pursuant to information provided by Adelphia and stored in BellSouth's AIN Selective Carrier Routing Service Control Point database. AIN Selective Carrier Routing shall utilize a set of Line Class Codes (LCCs) unique to a basic class of service assigned on an 'as needed basis. The same LCCs will be assigned in each central office where AIN Selective Carrier Routing is established.
- 4.4.5 Upon ordering of AIN Selective Carrier Routing Regional Service, Adelphia shall remit to BellSouth the Regional Service Order non-recurring charges set forth in Exhibit A of this Attachment. There shall be a non-recurring End Office Establishment Charge per office due at the addition of each central office where AIN Selective Carrier Routing will be utilized. Said non-recurring charge shall be as set forth in Exhibit A of this Attachment. For each Adelphia end user activated, there shall be a non-recurring End User Establishment charge as set forth in Exhibit A of this Attachment, payable to BellSouth pursuant to the terms of the General Terms and Conditions, incorporated herein by this reference. Adelphia shall pay the AIN Selective Carrier Routing Per Query Charge set forth in Exhibit A of this Attachment.
- 4.4.6 This Regional Service Order non-recurring charge will be non-refundable and will be paid with 1/2 coming up-front with the submission of all fully completed required forms, including: Regional Selective Carrier Routing (SCR) Order Request-Form A, Central Office AIN Selective Carrier Routing (SCR) Order Request - Form B, AIN_SCR Central Office Identification Form - Form C, AIN_SCR Routing Options Selection Form - Form D, and Routing Combinations Table - Form E. BellSouth has 30 days to respond to the client's fully completed firm order as a Regional Service Order. With the delivery of this firm order response to the client, BellSouth considers that the delivery schedule of this service commences. The remaining 1/2 of the Regional Service Order payment must be paid when at least 100% of the Central Offices listed on the original order have been turned up for the service.
- 4.4.7 The non-recurring End Office Establishment Charge will be billed to the client following BellSouth's normal monthly billing cycle for this type of order.

- 4.4.8 End-User Establishment Orders will not be turned-up until the 2nd payment is received for the Regional Service Order. The non-recurring End-User Establishment Charges will be billed to the client following BellSouth's normal monthly billing cycle for this type of order.
- 4.4.9 Additionally, the AIN Selective Carrier Routing Per Query Charge will be billed to the client following the normal billing cycle for per query charges.
- 4.4.10 All other network components needed, for example, unbundled switching and unbundled local transport, etc, will be billed according per contracted rates.

4.5 Packet Switching Capability

4.5.1 Definition

Packet Switching Capability. The packet switching capability network element is defined as the basic packet switching function of routing or forwarding packets, frames, cells or other data units based on address or other routing information contained in the packets, frames, cells or other data units, and the functions that are performed by Digital Subscriber Line Access Multiplexers, including but not limited to:

- 4.5.2 The ability to terminate copper customer loops (which includes both a low band voice channel and a high-band data channel, or solely a data channel);
- 4.5.3 The ability to forward the voice channels, if present, to a circuit switch or multiple circuit switches;
- 4.5.4 The ability to extract data units from the data channels on the loops, and
- 4.5.5 The ability to combine data units from multiple loops onto one or more trunks connecting to a packet switch or packet switches.
- 4.5.6 BellSouth shall be required to provide non-discriminatory access to unbundled packet switching capability only where each of the following conditions are satisfied:
 - 4.5.6.1 BellSouth has deployed digital loop carrier systems, including but not limited to, integrated digital loop carrier or universal digital loop carrier systems; or has deployed any other system in which fiber optic facilities replace copper facilities in the distribution section (e.g., end office to remote terminal, pedestal or environmentally controlled vault);
 - 4.5.6.2 There are no spare copper loops capable of supporting the xDSL services Adelphia seeks to offer;

4.5.6.3 BellSouth has not permitted any requesting carrier to deploy a Digital Subscriber Line Access Multiplexer at the remote terminal, pedestal or environmentally controlled vault or other interconnection point, nor has Adelphia obtained a virtual collocation arrangement at these subloop interconnection points as defined by 47 C.F.R. § 51.319 (b); and

4.5.6.4 BellSouth has deployed packet switching capability for its own use.

4.5.7 If there is a dispute as to whether BellSouth must provide Packet Switching, such dispute will be resolved according to the dispute resolution process set forth in Section of the General Terms and Conditions of this Agreement, incorporated herein by this reference.

4.6 Rates

The prices that Adelphia shall pay to BellSouth for Network Elements and Other Services are set forth in Exhibit D to this Attachment.

4.7 Operational Support Systems (OSS)

BellSouth has developed and made available the following mechanized systems by which Adelphia may submit LSRs electronically.

| | |
|------|-----------------------------------|
| LENS | Local Exchange Navigation System |
| EDI | Electronic Data Interchange |
| TAG | Telecommunications Access Gateway |

4.7.1 LSRs submitted by means of one of these interactive interfaces will incur an OSS electronic ordering charge as specified in the table below. An individual LSR will be identified for billing purposes by its Purchase Order Number (PON). LSRs submitted by means other than one of these interactive interfaces (mail, fax, courier, etc.) will incur a manual order charge as specified in the table below:

| OPERATIONAL SUPPORT SYSTEMS | AL, GA, LA, MS, NC, SC | FL, KY, TN |
|---|-----------------------------|------------|
| OSS LSR charge, per LSR received from the CLEC by one of the OSS interactive interfaces | \$3.50 | \$3.50 |
| | SOMECH | SOMECH |
| Incremental charge per LSR received from the CLEC by means other than one of the OSS interactive interfaces | See applicable rate element | \$19.99 |
| | | SOMAN |

4.7.2 Denial/Restoral OSS Charge

In the event Adelphia provides a list of customers to be denied and restored, rather than an LSR, each location on the list will require a separate PON and, therefore will be billed as one LSR per location.

4.7.3 Cancellation OSS Charge

Adelphia will incur an OSS charge for an accepted LSR that is later canceled by Adelphia.

Note: Supplements or clarifications to a previously billed LSR will not incur another OSS charge.

4.7.4 Network Elements and Other Services Manual Additive

- 4.7.4.1 The Commissions in some states have ordered per-element manual additive non-recurring charges (NRC) for Network Elements and Other Services ordered by means other than one of the interactive interfaces. These ordered Network Elements and Other Services manual additive NRCs will apply in these states, rather than the charge per LSR. The per-element charges are listed on the Rate Tables in Exhibit D.

5. Unbundled Network Element Combinations

- 5.1. Unbundled Network Element Combinations shall include: 1) Enhanced Extended Links (EELs) 2) UNE Loops/Special Access Combinations 3) Loop/Port Combinations and 4) Transport Combinations.

- 5.2 For purposes of this Section, references to “Currently Combined” network elements shall mean that such network elements are in fact already combined by BellSouth in the BellSouth network to provide service to a particular end user at a particular location.

5.3 EELs

- 5.3.1 Where facilities permit and where necessary to comply with an effective FCC and/or State Commission order, or as otherwise mutually agreed by the Parties, BellSouth shall offer access to loop and transport combinations, also known as the Enhanced Extended Link (“EEL”) as defined in Section 5.3.2 below.

- 5.3.2 Subject to Section 5.3.3 below, BellSouth will provide access to the EEL in the combinations set forth in 5.3.4 following. This offering is intended to provide connectivity from an end user’s location through that end user’s SWC to Adelphia’s POP serving wire center. The circuit must be connected to Adelphia’s switch for the purpose of provisioning telephone exchange service to Adelphia’s end-user customers. Except as set forth in Section 5.3.1.3, the EEL will be connected to Adelphia’s

facilities in Adelphia's collocation space at the POP SWC. Adelphia may purchase either BellSouth's access facilities or Dedicated Transport pursuant to this Agreement between Adelphia's POP and Adelphia's collocation space at the POP SWC.

- 5.3.3 BellSouth shall provide EEL combinations to Adelphia in Georgia regardless of whether or not such EELs are Currently Combined. In all other states, BellSouth shall make available to Adelphia those EEL combinations described in Section 5.3.4 below only to the extent such combinations are Currently Combined. Furthermore, BellSouth will make available EEL combinations to Adelphia in density Zone 1, as defined in 47 C.F.R. 69.123 as of January 1, 1999, in the Atlanta, GA; Miami, FL; Orlando, FL; Ft. Lauderdale, FL; Charlotte-Gastonia-Rock Hill, NC; Greensboro-Winston Salem-High Point, NC; Nashville, TN; and New Orleans, LA, MSAs regardless of whether or not such EELs are Currently Combined. Except as stated above, EELs will be provided to Adelphia only to the extent such network elements are Currently Combined.
- 5.3.4 EEL Combinations
 - 5.3.4.1 DS1 Interoffice Channel + DS1 Channelization + 2-wire VG Local Loop
 - 5.3.4.2 DS1 Interoffice Channel + DS1 Channelization + 4-wire VG Local Loop
 - 5.3.4.3 DS1 Interoffice Channel + DS1 Channelization + 2-wire ISDN Local Loop
 - 5.3.4.4 DS1 Interoffice Channel + DS1 Channelization + 4-wire 56 kbps Local Loop
 - 5.3.4.5 DS1 Interoffice Channel + DS1 Channelization + 4-wire 64 kbps Local Loop
 - 5.3.4.6 DS1 Interoffice Channel + DS1 Local Loop
 - 5.3.4.7 DS3 Interoffice Channel + DS3 Local Loop
 - 5.3.4.8 STS-1 Interoffice Channel + STS-1 Local Loop
 - 5.3.4.9 DS3 Interoffice Channel + DS3 Channelization + DS1 Local Loop
 - 5.3.4.10 STS-1 Interoffice Channel + DS3 Channelization + DS1 Local Loop
 - 5.3.4.11 2-wire VG Interoffice Channel + 2-wire VG Local Loop
 - 5.3.4.12 4wire VG Interoffice Channel + 4-wire VG Local Loop
 - 5.3.4.13 4-wire 56 kbps Interoffice Channel + 4-wire 56 kbps Local Loop

5.3.4.14 4-wire 64 kbps Interoffice Channel + 4-wire 64 kbps Local Loop

5.3.5 Special Access Service Conversions

5.3.5.1 Adelphia may not convert special access services to combinations of loop and transport network elements, whether or not Adelphia self-provides its entrance facilities (or obtains entrance facilities from a third party), unless Adelphia uses the combination to provide a significant amount of local exchange service, in addition to exchange access service, to a particular customer. To the extent Adelphia requests to convert any special access services to combinations of loop and transport network elements at UNE prices, Adelphia shall provide to BellSouth a letter certifying that Adelphia is providing a significant amount of local exchange service (as described in this Section) over such combinations. The certification letter shall also indicate under what local usage option Adelphia seeks to qualify for conversion of special access circuits. Adelphia shall be deemed to be providing a significant amount of local exchange service over such combinations if one of the following options is met:

5.3.5.1.1 Adelphia certifies that it is the exclusive provider of an end user's local exchange service. The loop-transport combinations must terminate at Adelphia's collocation arrangement in at least one BellSouth central office. This option does not allow loop-transport combinations to be connected to BellSouth's tariffed services. Under this option, Adelphia is the end user's only local service provider, and thus, is providing more than a significant amount of local exchange service. Adelphia can then use the loop-transport combinations that serve the end user to carry any type of traffic, including using them to carry 100 percent interstate access traffic; or

5.3.5.1.2 Adelphia certifies that it provides local exchange and exchange access service to the end user customer's premises and handles at least one third of the end user customer's local traffic measured as a percent of total end user customer local dialtone lines; and for DS1 circuits and above, at least 50 percent of the activated channels on the loop portion of the loop-transport combination have at least 5 percent local voice traffic individually, and the entire loop facility has at least 10 percent local voice traffic. When a loop-transport combination includes multiplexing, each of the individual DS1 circuits must meet this criteria. The loop-transport combination must terminate at Adelphia's collocation arrangement in at least one BellSouth central office. This option does not allow loop-transport combinations to be connected to BellSouth tariffed services; or

5.3.5.1.3 The requesting carrier certifies that at least 50 percent of the activated channels on a circuit are used to provide originating and terminating local dialtone service and at least 50 percent of the traffic on each of these local dialtone channels is local voice traffic, and that the entire loop facility has at least 33 percent local voice traffic.

- When a loop-transport combination includes multiplexing, each of the individual DS1 circuits must meet this criteria. This option does not allow loop-transport combinations to be connected to BellSouth's tariffed services. Under this option, collocation is not required. Adelphia does not need to provide a defined portion of the end user's local service, but the active channels on any loop-transport combination, and the entire facility, must carry the amount of local exchange traffic specified in this option.
- 5.3.5.2 After BellSouth has provisioned the loop-transport combination to Adelphia, or converted a special access arrangement to a loop-transport combination, BellSouth may at its sole discretion audit Adelphia records in order to verify the type of traffic being transmitted over combinations of loop and transport network elements. The audit shall be conducted by a third party independent auditor, and Adelphia shall be given thirty days written notice of scheduled audit. Such audit shall occur no more than one time in a calendar year, unless results of an audit find noncompliance with the significant amount of local exchange service requirement. In the event of noncompliance, Adelphia shall reimburse BellSouth for the cost of the audit. If, based on its audits, BellSouth concludes that Adelphia is not providing a significant amount of local exchange traffic over the combinations of loop and transport network elements as defined in Sections 5.3.5.1.1-5.3.5.1.3 above, BellSouth may file a complaint with the appropriate Commission, pursuant to the dispute resolution process as set forth in Section 12 of the General Terms and Conditions of this Agreement seeking a determination that BellSouth may convert such combinations of loop and transport network elements to special access services and obtain appropriate retroactive reimbursement from Adelphia.
- 5.3.5.3 For purposes of this Section 5.3.5, traffic is local if it is defined as such in Adelphia's state-approved local exchange tariff and/or it is subject to a reciprocal compensation arrangement between Adelphia and BellSouth.
- 5.3.6 Rates
- 5.3.6.1 Georgia
- 5.3.6.2 The non-recurring and recurring rates for the EEL Combinations of network elements set forth in Section 5.3.4, whether Currently Combined or new, are as set forth in Exhibit D of this Amendment.
- 5.3.6.3 On an interim basis, for combinations of loop and transport network elements not set forth in Section 5.3, where the elements are not Currently Combined but are ordinarily combined in BellSouth's network, the non-recurring and recurring charges for such UNE combinations shall be the sum of the stand-alone non-recurring and recurring charges of the network elements which make up the combination. These interim rates shall be subject to true-up based on the Commission's review of BellSouth's cost studies.

5.3.6.4 To the extent that Adelphia seeks to obtain other combinations of network elements that BellSouth ordinarily combines in its network which have not been specifically priced by the Commission when purchased in combined form, Adelphia, at its option, can request that such rates be determined pursuant to the Bona Fide Request/New Business Request (NBR) process set forth in this Agreement.

5.3.6.5 All Other States

5.3.6.5.1 Subject to Section 5.3.2 and 5.3.3 preceding, for all other states, the non-recurring and recurring rates for the Currently Combined EEL combinations set forth in Section 5.3.4 and other Currently Combined network elements will be the sum of the recurring rates for the individual network elements plus a non recurring charge set forth in Exhibit D of this Attachment.

5.3.6.6 Multiplexing

Where multiplexing functionality is required in connection with loop and transport combinations, such multiplexing will be provided at the rates and on the terms set forth in this Agreement.

5.4 Other Network Element Combinations

5.4.1 In the state of Georgia, BellSouth shall make available to Adelphia, in accordance with Section 5.4.2.1 below: (1) combinations of network elements other than EELs that are Currently Combined; and (2) combinations of network elements other than EELs that are not Currently Combined but that BellSouth ordinarily combines in its network. In all other states, BellSouth shall make available to Adelphia, in accordance with Section 5.4.2.2 below, combinations of network elements other than EELs only to the extent such combinations are Currently Combined.

5.4.2 Rates

5.4.2.1 Georgia

5.4.2.1.1 The non-recurring and recurring rates for Other Network Element combinations, whether Currently Combined or new, are as set forth in Exhibit D of this Attachment.

5.4.2.1.2 On an interim basis, for Other Network Element combinations where the elements are not Currently Combined but are ordinarily combined in BellSouth's network, the non-recurring and recurring charges for such UNE combinations shall be the sum of the stand-alone non-recurring and recurring charges of the network elements which make up the combination. These interim rates shall be subject to true-up based on the Commission's review of BellSouth's cost studies.

5.4.2.1.3 To the extent that Adelphia seeks to obtain other combinations of network elements that BellSouth ordinarily combines in its network which have not been specifically

priced by the Commission when purchased in combined form, Adelphia, at its option, can request that such rates be determined pursuant to the Bona Fide Request/New Business Request (NBR) process set forth in this Agreement.

5.4.2.2 All Other States

5.4.2.2.1 For all other states, the non-recurring and recurring rates for the Other Network Element Combinations that are Currently Combined will be the sum of the recurring rates for the individual network elements plus a non recurring charge set forth in Exhibit D of this Attachment.

5.5 UNE/Special Access Combinations

5.5.1 Additionally, BellSouth shall make available to Adelphia a combination of an unbundled loop and tariffed special access interoffice facilities. To the extent Adelphia will require multiplexing functionality in connection with such combination, BellSouth will provide access to multiplexing within the central office pursuant to the terms, conditions and rates set forth in its Access Services Tariffs. The tariffed special access interoffice facilities and any associated tariffed services, including but not limited to multiplexing, shall not be eligible for conversion to UNEs as described in Section 5.3.5 above.

5.5.2 Rates

5.5.2.1 The non-recurring and recurring rates for UNE/Special Access Combinations, which are Currently Combined, will be the sum of the recurring rates for the individual network elements plus a non recurring charge as set forth in Exhibit D of this Attachment.

5.6 Port/Loop Combinations

5.6.1 At Adelphia's request, BellSouth shall provide access to combinations of port and loop network elements, as set forth in Section 5.6.4 below, that are Currently Combined in BellSouth's network except as specified in Sections 5.6.1.1 and 5.6.1.2 below.

5.6.1.1 BellSouth shall not provide access to combinations of port and loop network elements in locations where, pursuant to FCC rules, BellSouth is not required to provide circuit switching as an unbundled network element.

5.6.1.2 In accordance with effective and applicable FCC rules, BellSouth shall not be required to provide circuit switching as an unbundled network element in density Zone 1, as defined in 47 C.F.R. 69.123 as of January 1, 1999 of the Atlanta, GA; Miami, FL;

Orlando, FL; Ft. Lauderdale, FL; Charlotte-Gastonia-Rock Hill, NC; Greensboro-Winston Salem-High Point, NC; Nashville, TN; and New Orleans, LA, MSAs to Adelphia if Adelphia's customer has 4 or more DS0 equivalent lines.

5.6.2 Definition

5.6.2.1 Combinations of port and loop network elements provide local exchange service for the origination or termination of calls. Section 5.6.4 following provides the combinations of port and loop network elements that may be ordered by Adelphia when Currently Combined except in those locations where BellSouth is not required to provide circuit switching, as set forth in Section 5.6.1.2 above.

5.6.2.2 In Georgia, BellSouth shall provide combinations of port and loop network elements to Adelphia regardless of whether or not such combinations are Currently Combined except in those locations where BellSouth is not required to provide circuit switching, as set forth in Section 5.6.1.2 above. In all other states, and subject to Sections 5.6.1.1 and 5.6.1.2 above, BellSouth shall provide combinations of port and loop network elements to Adelphia only to the extent such elements are Currently Combined.

5.6.3 Rates for Combinations of Loop and Port Network Elements

5.6.3.1 Rates for combinations of loop and port network elements, as set forth in Section 5.6.4, are provided in Exhibit D of this Attachment

5.6.3.2 Rates for Circuit Switching

5.6.3.2.1 Rates for circuit switching, where BellSouth is not required, pursuant to Sections 5.6.1.1 and 5.6.1.2, to provide circuit switching are as set forth in Exhibit D of this Attachment.

5.6.4 Combination Offerings

5.6.4.1 2-wire voice grade port, voice grade loop, unbundled end office switching, unbundled end office trunk port, common transport per mile per MOU, common transport facilities termination, tandem switching, and tandem trunk port.

5.6.4.2 2-wire voice grade DID port, voice grade loop, unbundled end office switching, unbundled end office trunk port, common transport per mile per MOU, common transport facilities termination, tandem switching, and tandem trunk port.

5.6.4.3 2-wire CENTREX port, voice grade loop, unbundled end office switching, unbundled end office trunk port, common transport per mile per MOU, common transport facilities termination, tandem switching, and tandem trunk port.

- 5.6.4.5. 2-wire ISDN Basic Rate Interface, voice grade loop, unbundled end office switching, unbundled end office trunk port, common transport per mile per MOU, common transport facilities termination, tandem switching, and tandem trunk port.
- 5.6.4.5 2-wire ISDN Primary Rate Interface, DS1 loop, unbundled end office switching, unbundled end office trunk port, common transport per mile per MOU, common transport facilities termination, tandem switching, and tandem trunk port.
- 5.6.4.6 4-wire DS1 Trunk port, DS1 Loop, unbundled end office switching, unbundled end office trunk port, common transport per mile per MOU, common transport facilities termination, tandem switching, and tandem trunk port.

6. Transport and Dark Fiber

BellSouth shall provide nondiscriminatory access, in accordance with 47 C.F.R. § 51.311 and Section 251(c)(3) of the Act, to interoffice transmission facilities on an unbundled basis to Adelphia for the provision of a telecommunications service. All of the negotiated rates, terms and conditions set forth in this Section pertain to the provision of unbundled transport and dark fiber.

6.1. Transport

6.1.1 Definition of Common (Shared) Transport

Common (Shared) Transport is an interoffice transmission path between two BellSouth end-offices, BellSouth end-office and a local tandem, or between two local tandems. Where BellSouth Network Elements are connected by intra-office wiring, such wiring is provided as a part of the Network Elements and is not Common (Shared) Transport. Common (Shared) Transport consists of BellSouth inter-office transport facilities and is unbundled from local switching.

6.1.2 Technical Requirements of Common (Shared) Transport

- 6.1.2.1 Common (Shared) Transport provided on DS1 or VT1.5 circuits, shall, at a minimum, meet the performance, availability, jitter, and delay requirements specified for Central Office to Central Office (“CO to CO”) connections in the appropriate industry standards.
- 6.1.2.2 Common (Shared) Transport provided on DS3 circuits, STS-1 circuits, and higher transmission bit rate circuits, shall, at a minimum, meet the performance, availability, jitter, and delay requirements specified for CO to CO connections in the appropriate industry standards.

- 6.1.2.3 BellSouth shall be responsible for the engineering, provisioning, and maintenance of the underlying equipment and facilities that are used to provide Common (Shared) Transport.
- 6.1.2.4 At a minimum, Common (Shared) Transport shall meet all of the requirements set forth in the applicable industry standard technical references.
- 6.2 Interoffice transmission facility network elements include:
 - 6.2.1 Dedicated transport, defined as BellSouth's transmission facilities, including all technically feasible capacity-related services including, but not limited to, DS1, DS3 and OCn levels, dedicated to a particular customer or carrier, that provide telecommunications between wire centers or switches owned by BellSouth, or between wire centers and switches owned by BellSouth and Adelphia.
 - 6.2.2 Dark Fiber transport, defined as BellSouth's optical transmission facilities without attached multiplexing, aggregation or other electronics;
 - 6.2.3 Shared transport, defined as transmission facilities shared by more than one carrier, including BellSouth, between end office switches, between end office switches and tandem switches, and between tandem switches, in BellSouth's network.
 - 6.2.4 BellSouth shall:
 - 6.2.4.1 Provide Adelphia exclusive use of interoffice transmission facilities dedicated to a particular customer or carrier, or shared use of the features, functions, and capabilities of interoffice transmission facilities shared by more than one customer or carrier;
 - 6.2.4.2 Provide all technically feasible transmission facilities, features, functions, and capabilities that Adelphia could use to provide telecommunications services;
 - 6.2.4.3 Permit, to the extent technically feasible, Adelphia to connect such interoffice facilities to equipment designated by Adelphia, including but not limited to, Adelphia's collocated facilities; and
 - 6.2.4.4 Permit, to the extent technically feasible, Adelphia to obtain the functionality provided by BellSouth's digital cross-connect systems in the same manner that BellSouth provides such functionality to interexchange carriers.
 - 6.2.5 Provided that the facility is used to transport a significant amount of local exchange services Adelphia shall be entitled to convert existing interoffice transmission facilities (i.e., special access) to the corresponding interoffice transport network element option.

6.3 Dedicated Transport

6.3.1 Definitions

- 6.3.2 Dedicated Transport is defined as BellSouth transmission facilities dedicated to a particular customer or carrier that provide telecommunications between wire centers owned by BellSouth or requesting telecommunications carriers, or between switches owned by BellSouth or requesting telecommunications carriers.
- 6.3.3 Unbundled Local Channel
- 6.3.4 Unbundled Local Channel as an individual UNE is the dedicated transmission path between Adelphia's Point of Presence and Adelphia's collocation arrangement at the BellSouth Serving Wire Center.
- 6.3.5 Unbundled Interoffice Channel.
- 6.3.6 Unbundled Interoffice Channel is the dedicated transmission path between BellSouth's Wire Centers. Except in the case of a loop and transport combination, Adelphia must be collocated at each end point of the Unbundled Interoffice Channel.
- 6.3.7 BellSouth shall offer Dedicated Transport on a nondiscriminatory basis in each of the following ways:
- 6.3.7.1 As capacity on a shared UNE facility.
- 6.3.7.2 As a circuit (e.g., DS0, DS1, DS3, OCn) dedicated to Adelphia. This circuit shall consist of an Unbundled Local Channel or an Unbundled Interoffice Channel or both.
- 6.3.8 When Dedicated Transport is provided it shall include:
- 6.3.8.1 Transmission equipment such as, line terminating equipment, amplifiers, and regenerators;
- 6.3.8.2 Inter-office transmission facilities such as optical fiber, copper twisted pair, and coaxial cable.
- 6.3.9 Rates for Dedicated Transport are listed in Exhibit D to this Attachment. If a rate is not included in this Attachment for a particular type of Dedicated Transport, such as rates for OCn transport, the Parties will negotiate the rates.
- 6.3.10 Technical Requirements
- 6.3.10.1 This Section sets forth technical requirements for all Dedicated Transport.
- 6.3.10.2 When BellSouth provides Dedicated Transport, the entire designated transmission service (e.g., DS0, DS1, DS3, OCn) shall be dedicated to Adelphia designated traffic.

- 6.3.10.3 BellSouth shall offer Dedicated Transport in all technologies that become available including, but not limited to, (1) DS0, DS1 and DS3 transport services and if and when available, OC3, OC12, OC48, and OC192 transport services, and (2) SONET at available transmission bit rates.
- 6.3.10.4 For DS1 or VT1.5 circuits, Dedicated Transport shall, at a minimum, meet the performance, availability, jitter, and delay requirements specified for Customer Interface to Central Office (“CI to CO”) connections in the appropriate industry standards.
- 6.3.10.5 Where applicable, for DS3, Dedicated Transport shall, at a minimum, meet the performance, availability, jitter, and delay requirements specified for CI to CO connections in the appropriate industry standards.
- 6.3.10.6 BellSouth shall offer the following interface transmission rates for Dedicated Transport:
- 6.3.10.6.1 DS0 Equivalent;
- 6.3.10.6.2 DS1 (Extended SuperFrame - ESF);
- 6.3.10.6.3 DS3 (signal must be framed);
- 6.3.10.6.4 OCn (OC3, OC12, OC48, or OC192) (if and when available);
- 6.3.10.6.5 SDH (Synchronous Digital Hierarchy) Standard interface rates in accordance with International Telecommunications Union (ITU) Recommendation G.707 and Plesiochronous Digital Hierarchy (PDH) rates per ITU Recommendation G.704.
- 6.3.10.6.6 When Dedicated Transport is provided, BellSouth shall design it according to BellSouth’s network infrastructure to allow for the termination points specified by Adelphia.
- 6.3.11 At a minimum, Dedicated Transport shall meet each of the requirements set forth in the applicable industry technical references.
- 6.3.11.1 BellSouth Technical References:
- 6.3.11.2 TR-TSY-000191 Alarm Indication Signals Requirements and Objectives, Issue 1, May 1986.
- 6.3.11.3 TR 73501 LightGate[®] Service Interface and Performance Specifications, Issue D, June 1995.

6.3.11.4 TR 73525 MegaLink[®] Service, MegaLink Channel Service & MegaLink Plus Service Interface and Performance Specifications, Issue C, May 1996.

6.4 Unbundled Channelization

6.4.1 BellSouth agrees to offer nondiscriminatory access to Unbundled Channelization when available pursuant to following terms and conditions and at the rates set forth in the Attachment.

6.4.2 Definition

6.4.2.1 Unbundled Channelization (UC) provides the multiplexing capability that will allow a DS1 (1.544 Mbps) or DS3 (44.736 Mbps) or STS-1 Unbundled Network Element (UNE) or collocation cross-connect to be multiplexed or channelized at a BellSouth central office. This can be accomplished through the use of a stand-alone multiplexer or a digital cross-connect system at the discretion of BellSouth. Once UC has been installed, Adelphia can have channels activated on an as-needed basis by having BellSouth connect lower level UNEs via Central Office Channel Interfaces (COCI).

6.4.3 Channelization capabilities will be as follows:

6.4.3.1 DS3 Channelization System: An element that channelizes a DS3 signal into 28 DS1s/STS-1s.

6.4.3.2 DS1 Channelization System: An element that channelizes a DS1 signal into 24 DS0s.

6.4.3.3 Central Office Channel Interfaces (COCI): Elements that can be activated on a channelization system.

6.4.4 DS1 Central Office Channel Interface elements can be activated on a DS3 Channelization System.

6.4.5 Voice Grade and Digital Data Central Office Channel Interfaces can be activated on a DS1 Channelization System.

6.4.6 AMI and B8ZS line coding with either Super Frame (SF) and Extended Super Frame (ESF) framing formats will be supported as options.

6.4.7 COCI will be billed on the lower level UNE order that is interfacing with the UC arrangement and will have to be compatible with those UNEs.

6.4.8 Channelization may be incorporated within dedicated transport or ordered as a stand-alone capability, which requires either the high or low speed side to be connected to collocation.

6.4.9 Technical Requirements

6.4.9.1 In order to assure proper operation with BST provided central office multiplexing functionality, the customer's channelization equipment must adhere strictly to form and protocol standards. Separate standards exist for the multiplex channel bank, for voice frequency encoding, for various signaling schemes, and for subrate digital access.

6.4.9.2 DS0 to DS1 Channelization

6.4.9.2.1 The DS1 signal must be framed utilizing the framing structure defined in ANSI T1.107, *Digital Hierarchy Formats Specifications* and ANSI T1.403.02, *DS1 Robbed-bit Signaling State Definitions*. DS0 to DS1 Channelization requirements are essentially the same as defined in BellSouth Technical Reference 73525, *MegaLink[®] Service, MegaLink[®] Channel Service, MegaLink[®] Plus Service, and MegaLink[®] Light Service Interface and Performance Specification*.

6.4.9.3 DS1 to DS3 Channelization

6.4.9.3.1 The DS3 signal must be framed utilizing the framing structure define in ANSI T1.107, *Digital Hierarchy Formats Specifications*. DS1 to DS3 Channelization requirements are essentially the same as defined in BellSouth Technical Reference 73501, *LightGate[®] Service Interface and Performance Specifications*. The asynchronous M13 multiplex format (combination of M12 and M23 formats) is specified for terminal equipment that multiplexes 28 DS1s into a DS3.

6.4.9.4 DS1 to STS Channelization

6.4.9.4.1 The STS-1 signal must be framed utilizing the framing structure define in ANSI T1.105, *Synchronous Optical Network (SONET) – Basic Description Including Multiplex Structure, Rates and Formats* and T1.105.02, *Synchronous Optical Network (SONET) – Payload Mappings*. DS1 to STS Channelization requirements are essentially the same as defined in BellSouth Technical Reference TR 73501, *LightGate[®] Service Interface and Performance Specifications*

6.5 Dark Fiber Transport

6.5.1 Definition

6.5.2 Dark Fiber is an optical transmission facility without attached multiplexing, aggregation or other electronics that connects two points within BellSouth's network. Dark Fiber is unused strands of optical fiber. It may be strands of optical fiber existing

in aerial or underground structure. No line terminating elements terminated to such strands to operationalize its transmission capabilities will be available. No regeneration or optical amplification will be included with this element.

6.5.3 Requirements

- 6.5.3.1 BellSouth shall make available Dark Fiber on a nondiscriminatory basis where it exists in BellSouth's network and where, as a result of future building or deployment, it becomes available. If BellSouth has pre-existing plans to make specific use of the fiber within a two year planning period, there is no requirement to provide said fiber to Adelphia, provided that upon Adelphia's request, BellSouth shall provide written certification to Adelphia that BellSouth has plans to use such fiber and shall describe generally its plan to make such use, subject to Adelphia's representative signing a separate confidentiality agreement with respect to the disclosure of such plans.
- 6.5.3.2 If the requested dark fiber has any lightwave repeater equipment interspliced to it, BellSouth will remove such equipment at Adelphia's request subject to time and materials charges.
- 6.5.3.3 Adelphia may test the quality of the Dark Fiber to confirm its usability and performance specifications.
- 6.5.3.4 BellSouth shall use its best efforts to provide to Adelphia information regarding the location, availability and performance of Dark Fiber within ten (10) business days for a records based answer and twenty (20) business days for a field based answer, after receiving a request from Adelphia ("Request"). Within such time period, BellSouth shall send written confirmation of availability of the Dark Fiber ("Confirmation"). From the time of the Request to forty-five (45) days after Confirmation, BellSouth shall hold such requested Dark Fiber for Adelphia's use and may not allow any other party to use such media, including BellSouth.
- 6.5.3.5 BellSouth shall use its best efforts to make Dark Fiber available to Adelphia within thirty (30) business days after it receives written confirmation from Adelphia that the Dark Fiber previously deemed available by BellSouth is wanted for use by Adelphia. This includes identification of appropriate connection points (e.g., Light Guide Interconnection (LGX) or splice points) to enable Adelphia to connect or splice Adelphia provided transmission media (e.g., optical fiber) or equipment to the Dark Fiber.
- 6.5.3.6 Dark Fiber shall meet the manufacturer's design specifications.
- 6.5.3.7 Adelphia may splice and test Dark Fiber obtained from BellSouth using Adelphia or Adelphia designated personnel. BellSouth shall provide appropriate interfaces to allow splicing and testing of Dark Fiber. BellSouth shall provide an excess cable

length of 25 feet minimum (for fiber in underground conduit) to allow the uncoiled fiber to reach from the manhole to a splicing van.

6.6 Rates

6.6.1 The prices that Adelphia shall pay to BellSouth for Network Elements and Other Services are set forth in Exhibit D to this Attachment.

6.7 Operational Support Systems (OSS)

6.7.1 BellSouth has developed and made available the following mechanized systems by which Adelphia may submit LSRs electronically.

| | |
|------|-----------------------------------|
| LENS | Local Exchange Navigation System |
| EDI | Electronic Data Interchange |
| TAG | Telecommunications Access Gateway |

6.7.2 LSRs submitted by means of one of these interactive interfaces will incur an OSS electronic ordering charge as specified in the table below. An individual LSR will be identified for billing purposes by its Purchase Order Number (PON). LSRs submitted by means other than one of these interactive interfaces (mail, fax, courier, etc.) will incur a manual order charge as specified in the table below:

| OPERATIONAL SUPPORT SYSTEMS | AL, GA, LA, MS, NC, SC | FL, KY, TN |
|---|-----------------------------|------------|
| OSS LSR charge, per LSR received from the CLEC by one of the OSS interactive interfaces | \$3.50 | \$3.50 |
| | SOMECH | SOMECH |
| Incremental charge per LSR received from the CLEC by means other than one of the OSS interactive interfaces | See applicable rate element | \$19.99 |
| | | SOMAN |

6.7.3 Denial/Restoral OSS Charge

6.7.3.1 In the event Adelphia provides a list of customers to be denied and restored, rather than an LSR, each location on the list will require a separate PON and, therefore will be billed as one LSR per location.

6.7.4 Cancellation OSS Charge

6.7.4.1 Adelphia will incur an OSS charge for an accepted LSR that is later canceled by Adelphia.

Note: Supplements or clarifications to a previously billed LSR will not incur another OSS charge.

6.7.5 Network Elements and Other Services Manual Additive

- 6.7.5.1 The Commissions in some states have ordered per-element manual additive non-recurring charges (NRC) for Network Elements and Other Services ordered by means other than one of the interactive interfaces. These ordered Network Elements and Other Services manual additive NRCs will apply in these states, rather than the charge per LSR. The per-element charges are listed on the Rate Tables in Exhibit D.

7. BellSouth SWA 8XX Toll Free Dialing Ten Digit Screening Service

All of the negotiated rates, terms and conditions set forth in this Section pertain to the provision of 8XX Access Ten Digit Screening Services.

7.1 BellSouth SWA 8XX Toll Free Dialing Ten Digit Screening Service database

7.1.1 The BellSouth SWA 8XX Toll Free Dialing Ten Digit Screening Service database (herein known as 8XX SCP) is a SCP that contains customer record information and functionality to provide call-handling instructions for 8XX calls. The 8XX SCP IN software stores data downloaded from the national SMS and provides the routing instructions in response to queries from the SSP or tandem. The BellSouth SWA 8XX Toll Free Dialing Ten Digit Screening Service (herein know as 8XX TFD), utilizes the 8XX SCP to provide identification and routing of the 8XX calls, based on the ten digits dialed. 8XX TFD is provided with or without POTS number delivery, dialing number delivery, and other optional complex features as selected by Adelphia. BellSouth shall provide 8XX TFD in accordance with the following:

7.1.2 Technical Requirements

7.1.2.1 BellSouth shall provide Adelphia with nondiscriminatory access to the 8XX record information located in the 8XX SCP. The 8XX SCP contains current records as received from the national SMS and will provide for routing 8XX originating calls based on the dialed ten digit 8XX number.

7.1.2.2 The 8XX SCP is designated to receive and respond to queries using the American National Standard Specification of Signaling System Seven (SS7) protocol. The 8XX SCP shall determine the carrier identification based on all ten digits of the dialed number and route calls to the carrier, POTS number, dialing number and/or other optional feature selected by Adelphia.

7.1.2.3 The SCP shall also provide, at Adelphia's option, such additional feature as described in SR-TSV-002275 (BOC Notes on BellSouth Networks, SR-TSV-002275, Issue 2, (Telcordia (formerly BellCore), April 1994)) as are available to BellSouth. These may include but are not limited to:

7.1.2.3.1 Network Management;

7.1.2.3.2 Customer Sample Collection; and

7.1.2.3.3 Service Maintenance.

7.2 Automatic Location Identification/Data Management System (ALI/DMS)

7.2.1 The ALI/DMS Database contains end user information (including name, address, telephone information, and sometimes special information from the local service provider or end user) used to determine to which Public Safety Answering Point (PSAP) to route the call. The ALI/DMS database is used to provide more routing flexibility for E911 calls than Basic 911. BellSouth shall provide the Emergency Services Database in accordance with the following:

7.3 Rates

The prices that Adelphia shall pay to BellSouth for Services rendered pursuant to Section 7 are set forth in Exhibit D to this Attachment.

8 Line Information Database (LIDB)

8.1 All of the negotiated rates, terms and conditions set forth in this Section pertain to the provision of LIDB.

8.2 BellSouth will store in its LIDB only records relating to service in the BellSouth region. The LIDB Storage Agreement is included in this Attachment.

8.2.1 Definition

8.2.2 The Line Information Database (LIDB) is a transaction-oriented database accessible through Common Channel Signaling (CCS) networks. It contains records associated with end user Line Numbers and Special Billing Numbers. LIDB accepts queries from other Network Elements and provides appropriate responses. The query originator need not be the owner of LIDB data. LIDB queries include functions such as screening billed numbers that provides the ability to accept Collect or Third Number Billing calls and validation of Telephone Line Number based non-proprietary calling cards. The interface for the LIDB functionality is the interface between BellSouth's CCS network and other CCS networks. LIDB also interfaces to administrative systems.

8.2.3 Technical Requirements

8.2.4 BellSouth will offer to Adelphia any additional capabilities that are developed for LIDB during the life of this Agreement.

8.2.4.1 BellSouth shall process Adelphia's Customer records in LIDB at least at parity with BellSouth customer records, with respect to other LIDB functions. BellSouth shall indicate to Adelphia what additional functions (if any) are performed by LIDB in the BellSouth network.

8.2.4.2 Within two (2) weeks after a request by Adelphia, BellSouth shall provide Adelphia with a list of the customer data items, which Adelphia would have to provide in order to support each required LIDB function. The list shall indicate which data items are essential to LIDB function, and which are required only to support certain services. For each data item, the list shall show the data formats, the acceptable values of the data item and the meaning of those values.

8.2.4.3 BellSouth shall provide LIDB systems for which operating deficiencies that would result in calls being blocked shall not exceed 30 minutes per year.

8.2.4.4 BellSouth shall provide LIDB systems for which operating deficiencies that would not result in calls being blocked shall not exceed 12 hours per year.

- 8.2.4.5 BellSouth shall provide LIDB systems for which the LIDB function shall be in overload no more than 12 hours per year.
- 8.2.4.6 All additions, updates and deletions of Adelphia data to the LIDB shall be solely at the direction of Adelphia. Such direction from Adelphia will not be required where the addition, update or deletion is necessary to perform standard fraud control measures (e.g., calling card auto-deactivation).
- 8.2.4.7 BellSouth shall provide priority updates to LIDB for Adelphia data upon Adelphia's request (e.g., to support fraud detection), via password-protected telephone card, facsimile, or electronic mail within one hour of notice from the established BellSouth contact.
- 8.2.4.8 BellSouth shall provide LIDB systems such that no more than 0.01% of Adelphia customer records will be missing from LIDB, as measured by Adelphia audits. BellSouth will audit Adelphia records in LIDB against DBAS to identify record mismatches and provide this data to a designated Adelphia contact person to resolve the status of the records and BellSouth will update system appropriately. BellSouth will refer record of mis-matches to Adelphia within one business day of audit. Once reconciled records are received back from Adelphia, BellSouth will update LIDB the same business day if less than 500 records are received before 1:00PM Central Time. If more than 500 records are received, BellSouth will contact Adelphia to negotiate a time frame for the updates, not to exceed three business days.
- 8.2.4.9 BellSouth shall perform backup and recovery of all of Adelphia's data in LIDB including sending to LIDB all changes made since the date of the most recent backup copy, in at least the same time frame BellSouth performs backup and recovery of BellSouth data in LIDB for itself. Currently, BellSouth performs backups of the LIDB for itself on a weekly basis and when a new software release is scheduled, a backup is performed prior to loading the new release.
- 8.2.4.10 BellSouth shall provide Adelphia with LIDB reports of data, which are missing or contain errors, as well as any misrouted errors, within a reasonable time period as negotiated between Adelphia and BellSouth.
- 8.2.4.11 BellSouth shall prevent any access to or use of Adelphia data in LIDB by BellSouth personnel that are outside of established administrative and fraud control personnel, or by any other Party that is not authorized by Adelphia in writing.
- 8.2.4.12 BellSouth shall provide Adelphia performance of the LIDB Data Screening function, which allows a LIDB to completely or partially deny specific query originators access to LIDB data owned by specific data owners, for Customer Data that is part of an NPA-NXX or RAO-0/1XX wholly or partially owned by Adelphia at least at parity with BellSouth Customer Data. BellSouth shall obtain from Adelphia the screening

- information associated with LIDB Data Screening of Adelphia data in accordance with this requirement. BellSouth currently does not have LIDB Data Screening capabilities. When such capability is available, BellSouth shall offer it to Adelphia under the Bona Fide Request/New Business Process as set forth in General Terms and Conditions.
- 8.2.4.13 BellSouth shall accept queries to LIDB associated with Adelphia customer records, and shall return responses in accordance with industry standards.
- 8.2.4.14 BellSouth shall provide mean processing time at the LIDB within 0.50 seconds under normal conditions as defined in industry standards.
- 8.2.4.15 BellSouth shall provide processing time at the LIDB within 1 second for 99% of all messages under normal conditions as defined in industry standards.
- 8.2.5 Interface Requirements
- 8.2.6 BellSouth shall offer LIDB in accordance with the requirements of this subsection.
- 8.2.6.1 The interface to LIDB shall be in accordance with the technical references contained within.
- 8.2.6.2 The CCS interface to LIDB shall be the standard interface described herein.
- 8.2.6.3 The LIDB Data Base interpretation of the ANSI-TCAP messages shall comply with the technical reference herein. Global Title Translation shall be maintained in the signaling network in order to support signaling network routing to the LIDB.
- 8.3 Rates**
- The prices that Adelphia shall pay to BellSouth for Services rendered pursuant to Section 8 are set forth in Exhibit D to this Attachment.

9 Signaling

9.1 All of the negotiated rates, terms and conditions set forth in this Section pertain to the provision of Signaling Transport Services.

9.2 BellSouth shall offer nondiscriminatory access to signaling and access to BellSouth's signaling systems and databases subject to compatibility testing and at the rates set forth in this Attachment. Available signaling elements include signaling links, signal transfer points and service control points. Signaling functionality will be available with both A-link and B-link connectivity.

9.3 Signaling Link Transport

9.3.1 Definition Signaling Link Transport is a set of two or four dedicated 56 Kbps. transmission paths between CLEC-designated Signaling Points of Interconnection (SPOI) that provides appropriate physical diversity.

9.3.2 Technical Requirements

9.3.2.1 Signaling Link Transport shall consist of full duplex mode 56 kbps transmission paths.

9.3.3 Of the various options available, Signaling Link Transport shall perform in the following two ways:

9.3.3.1 As an "A-link" which is a connection between a switch or SCP and a home Signaling Transfer Point Switch (STP) pair; and

9.3.3.2 As a "B-link" which is a connection between two STP pairs in different company networks (e.g., between two STP pairs for two Competitive Local Exchange Carriers (CLECs)).

9.3.4 Signaling Link Transport shall consist of two or more signaling link layers as follows:

9.3.4.1 An A-link layer shall consist of two links.

9.3.4.2 A B-link layer shall consist of four links.

9.3.5 A signaling link layer shall satisfy a performance objective such that:

9.3.5.1 There shall be no more than two minutes down time per year for an A-link layer; and

9.3.5.2 There shall be negligible (less than 2 seconds) down time per year for a B-link layer.

- 9.3.5.3 A signaling link layer shall satisfy interoffice and intraoffice diversity of facilities and equipment, such that:
- 9.3.5.3.1 No single failure of facilities or equipment causes the failure of both links in an A-link layer (i.e., the links should be provided on a minimum of two separate physical paths end-to-end); and
- 9.3.5.3.2 No two concurrent failures of facilities or equipment shall cause the failure of all four links in a B-link layer (i.e., the links should be provided on a minimum of three separate physical paths end-to-end).

9.3.5.4 Interface Requirements

- 9.3.5.4.1 There shall be a DS1 (1.544 Mbps) interface at the Adelphia designated SPOIs. Each 56 kbps transmission path shall appear as a DS0 channel within the DS1 interface.

9.4 Signaling Transfer Points (STPs)

- 9.4.1 Definition - Signaling Transfer Points is a signaling network function that includes all of the capabilities provided by the signaling transfer point switches (STPs) and their associated signaling links which enable the exchange of SS7 messages among and between switching elements, database elements and signaling transfer point switches.

9.4.2 Technical Requirements

- 9.4.2.1 STPs shall provide access to Network Elements connected to BellSouth SS7 network. These include:
- 9.4.2.1.1 BellSouth Local Switching or Tandem Switching;
- 9.4.2.1.2 BellSouth Service Control Points/DataBases;
- 9.4.2.1.3 Third-party local or tandem switching;
- 9.4.2.1.4 Third-party-provided STPs.
- 9.4.2.2 The connectivity provided by STPs shall fully support the functions of all other Network Elements connected to the BellSouth SS7 network. This explicitly includes the use of the BellSouth SS7 network to convey messages which neither originate nor terminate at a signaling end point directly connected to the BellSouth SS7 network (i.e., transient messages). When the BellSouth SS7 network is used to convey transient messages, there shall be no alteration of the Integrated Services Digital Network User Part (ISDNUP) or Transaction Capabilities Application Part (TCAP) user data that constitutes the content of the message.

- 9.4.2.3 If a BellSouth tandem switch routes calling traffic, based on dialed or translated digits, on SS7 trunks between an Adelphia local switch and third party local switch, the BellSouth SS7 network shall convey the TCAP messages that are necessary to provide Call Management features (Automatic Callback, Automatic Recall, and Screening List Editing) between Adelphia local STPs and the STPs that provide connectivity with the third party local switch, even if the third party local switch is not directly connected to BellSouth STPs.
- 9.4.2.4 STPs shall provide all functions of the MTP as defined in the applicable industry standard technical references.
- 9.4.2.5 STPs shall provide all functions of the SCCP necessary for Class 0 (basic connectionless) service, as defined in Telcordia (formerly BellCore) ANSI Interconnection Requirements. In particular, this includes Global Title Translation (GTT) and SCCP Management procedures, as specified in T1.112.4. In cases where the destination signaling point is a Adelphia or third party local or tandem switching system directly connected to BellSouth SS7 network, BellSouth shall perform final GTT of messages to the destination and SCCP Subsystem Management of the destination. In all other cases, BellSouth shall perform intermediate GTT of messages to a gateway pair of STPs in an SS7 network connected with BellSouth SS7 network, and shall not perform SCCP Subsystem Management of the destination. If BellSouth performs final GTT to a Adelphia database, then Adelphia agrees to provide BellSouth with the Destination Point Code for the Adelphia database.
- 9.4.2.6 STPs shall provide on a non-discriminatory basis all functions of the OMAP commonly provided by STPs, as specified in ANSI T1.116-1990 American National Standard for Telecommunications - Signaling System Number 7 (SS7) - Operations, Maintenance and Administration Part (OMAP). All OMAP functions will be on a "where available" basis and can include:
- 9.4.2.6.1 MTP Routing Verification Test (MRVT); and
- 9.4.2.6.2 SCCP Routing Verification Test (SRVT).
- 9.4.2.7 In cases where the destination signaling point is a BellSouth local or tandem switching system or database, or is an Adelphia or third party local or tandem switching system directly connected to the BellSouth SS7 network, STPs shall perform MRVT and SRVT to the destination signaling point. In all other cases, STPs shall perform MRVT and SRVT to a gateway pair of STPs in an SS7 network connected with the BellSouth SS7 network. This requirement shall be superseded by the specifications for Internetwork MRVT and SRVT if and when these become approved ANSI standards and available capabilities of BellSouth STPs, and if mutually agreed upon by Adelphia and BellSouth.

9.4.2.8 STPs shall be on parity with BellSouth.

9.4.2.9 SS7 Advanced Intelligent Network (AIN) Access

9.4.2.9.1 When technically feasible and upon request by Adelphia, SS7 Access shall be made available in association with switching. SS7 AIN Access is the provisioning of AIN 0.1 triggers in an equipped BellSouth local switch and interconnection of the BellSouth SS7 network with the Adelphia SS7 network to exchange TCAP queries and responses with an Adelphia SCP.

9.4.2.9.2 SS7 AIN Access shall provide Adelphia SCP access to BellSouth local switch in association with switching via interconnection of BellSouth SS7 and Adelphia SS7 Networks. BellSouth shall offer SS7 access through its STPs. If BellSouth requires a mediation device on any part of its network specific to this form of access, BellSouth must route its messages in the same manner. The interconnection arrangement shall result in the BellSouth local switch recognizing the Adelphia SCP as at least at parity with BellSouth's SCP's in terms of interfaces, performance and capabilities.

9.4.3 Interface Requirements

9.4.3.1 BellSouth shall provide the following STPs options to connect Adelphia or Adelphia-designated local switching systems or STPs to the BellSouth SS7 network:

9.4.3.1.1 An A-link interface from Adelphia local switching systems; and,

9.4.3.1.2 A B-link interface from Adelphia local STPs.

9.4.3.2 Each type of interface shall be provided by one or more sets (layers) of signaling links.

9.4.3.3 The Signaling Point of Interconnection (SPOI) for each link shall be located at a cross-connect element, such as a DSX-1, in the Central Office (CO) where BellSouth STP is located. There shall be a DS1 or higher rate transport interface at each of the SPOIs. Each signaling link shall appear as a DS0 channel within the DS1 or higher rate interface. BellSouth shall offer higher rate DS1 signaling for interconnecting Adelphia local switching systems or STPs with BellSouth STPs as soon as these become approved ANSI standards and available capabilities of BellSouth STPs. BellSouth and Adelphia will work jointly to establish mutually acceptable SPOIs.

9.4.3.4 BellSouth CO shall provide intraoffice diversity between the SPOIs and BellSouth STPs, so that no single failure of intraoffice facilities or equipment shall cause the failure of both B-links in a layer connecting to a BellSouth STP. BellSouth and Adelphia will work jointly to establish mutually acceptable SPOIs.

- 9.4.3.5 STPs shall provide all functions of the MTP as defined in the applicable industry standard technical references.
- 9.4.3.6 Message Screening
- 9.4.3.6.1 BellSouth shall set message screening parameters so as to accept valid messages from Adelphia local or tandem switching systems destined to any signaling point within BellSouth's SS7 network where the Adelphia switching system has a legitimate signaling relation.
- 9.4.3.6.2 BellSouth shall set message screening parameters so as to pass valid messages from Adelphia local or tandem switching systems destined to any signaling point or network accessed through BellSouth's SS7 network where the Adelphia switching system has a legitimate signaling relation.
- 9.4.3.6.3 BellSouth shall set message screening parameters so as to accept and pass/send valid messages destined to and from Adelphia from any signaling point or network interconnected through BellSouth's SS7 network where the Adelphia SCP has a legitimate signaling relation.
- 9.4.4 STPs shall be equal to or better than all of the requirements for STPs set forth in the applicable industry standard technical references.

9.5 Service Control Points/Databases

9.5.1 Definition

- 9.5.1.1 Databases are the Network Elements that provide the functionality for storage of, access to, and manipulation of information required to offer a particular service and/or capability. Databases include, but are not limited to: Local Number Portability, LIDB, Toll Free Number Database, Automatic Location Identification/Data Management System, Calling Name Database, access to Service Creation Environment and Service Management System (SCE/SMS) application databases and Directory Assistance.
- 9.5.2 A Service Control Point (SCP) is a specific type of Database functionality deployed in a Signaling System 7 (SS7) network that executes service application logic in response to SS7 queries sent to it by a switching system also connected to the SS7 network. Service Management Systems provide operational interfaces to allow for provisioning, administration and maintenance of subscriber data and service application data stored in SCPs.

9.5.3 Technical Requirements for SCPs/Databases

- 9.5.3.1 Requirements for SCPs/Databases within this section address storage of information, access to information (e.g. signaling protocols, response times), and administration of information (e.g., provisioning, administration, and maintenance). All SCPs/Databases shall be provided to Adelphia in accordance with the following requirements.
- 9.5.3.2 BellSouth shall provide physical access to SCPs through the SS7 network and protocols with TCAP as the application layer protocol.
- 9.5.3.3 BellSouth shall provide physical interconnection to databases via industry standard interfaces and protocols (e.g. SS7, ISDN and X.25).
- 9.5.3.4 The reliability of interconnection options shall be consistent with requirements for diversity and survivability.
- 9.5.4 Database Availability
- 9.5.4.1 Call processing databases shall have a maximum unscheduled availability of 30 minutes per year. Unavailability due to software and hardware upgrades shall be scheduled during minimal usage periods and only be undertaken upon proper notification to providers, which might be impacted. Any downtime associated with the provision of call processing related databases will impact all service providers, including BellSouth, equally.
- 9.5.4.2 The operational interface provided by BellSouth shall complete Database transactions (i.e., add, modify, delete) for Adelphia customer records stored in BellSouth databases within 3 days, or sooner where BellSouth provisions its own customer records within a shorter interval.

9.6 Local Number Portability Database

9.6.1 Definition

- 9.6.2 The Permanent Number Portability (PNP) database supplies routing numbers for calls involving numbers that have been ported from one local service provider to another. PNP is currently being worked in industry forums. The results of these forums will dictate the industry direction of PNP. BellSouth agrees to provide access to the PNP database at rates, terms and conditions as set forth by BellSouth and in accordance with an effective FCC or Commission directive.

9.7 SS7 Network Interconnection

9.7.1 Definition.

- 9.7.2 SS7 Network Interconnection is the interconnection of Adelphia local Signaling Transfer Point Switches (STP) and Adelphia local or tandem switching systems with

- BellSouth STPs. This interconnection provides connectivity that enables the exchange of SS7 messages among BellSouth switching systems and databases (DBs), Adelphia local or tandem switching systems, and other third-party switching systems directly connected to the BellSouth SS7 network.
- 9.7.3 Technical Requirements
- 9.7.3.1 SS7 Network Interconnection shall provide connectivity to all components of the BellSouth SS7 network. These include:
- 9.7.3.1.1 BellSouth local or tandem switching systems;
- 9.7.3.1.2 BellSouth DBs; and
- 9.7.3.1.3 Other third-party local or tandem switching systems.
- 9.7.4 The connectivity provided by SS7 Network Interconnection shall fully support the functions of BellSouth switching systems and DBs and Adelphia or other third-party switching systems with A-link access to the BellSouth SS7 network.
- 9.7.5 If traffic is routed based on dialed or translated digits between an Adelphia local switching system and a BellSouth or other third-party local switching system, either directly or via a BellSouth tandem switching system, then it is a requirement that the BellSouth SS7 network convey via SS7 Network Interconnection the TCAP messages that are necessary to provide Call Management services (Automatic Callback, Automatic Recall, and Screening List Editing) between the Adelphia local STPs and BellSouth or other third-party local switch.
- 9.7.6 When the capability to route messages based on Intermediate Signaling Network Identifier (ISNI) is generally available on BellSouth STPs, the BellSouth SS7 Network shall also convey TCAP messages using SS7 Network Interconnection in similar circumstances where the BellSouth switch routes traffic based on a Carrier Identification Code (CIC).
- 9.7.7 SS7 Network Interconnection shall provide all functions of the MTP as specified in ANSI T1.111. This includes:
- 9.7.7.1 Signaling Data Link functions, as specified in ANSI T1.111.2;
- 9.7.7.2 Signaling Link functions, as specified in ANSI T1.111.3; and
- 9.7.7.3 Signaling Network Management functions, as specified in ANSI T1.111.4.
- 9.7.8 SS7 Network Interconnection shall provide all functions of the SCCP necessary for Class 0 (basic connectionless) service, as specified in ANSI T1.112. In particular, this includes Global Title Translation (GTT) and SCCP Management procedures, as

- specified in T1.112.4. Where the destination signaling point is a BellSouth switching system or DB, or is another third-party local or tandem switching system directly connected to the BellSouth SS7 network, SS7 Network Interconnection shall include final GTT of messages to the destination and SCCP Subsystem Management of the destination. Where the destination signaling point is an Adelphia local or tandem switching system, SS7 Network Interconnection shall include intermediate GTT of messages to a gateway pair of Adelphia local STPs, and shall not include SCCP Subsystem Management of the destination.
- 9.7.9 SS7 Network Interconnection shall provide all functions of the Integrated Services Digital Network User Part (ISDNUP), as specified in ANSI T1.113.
- 9.7.10 SS7 Network Interconnection shall provide all functions of the TCAP, as specified in ANSI T1.114.
- 9.7.11 If and when Internetwork MTP Routing Verification Test (MRVT) and SCCP Routing Verification Test (SRVT) become approved ANSI standards and available capabilities of BellSouth STPs, SS7 Network Interconnection shall provide these functions of the OMAP.
- 9.7.12 SS7 Network Interconnection shall be equal to or better than the following performance requirements:
- 9.7.12.1 MTP Performance, as specified in ANSI T1.111.6;
- 9.7.12.2 SCCP Performance, as specified in ANSI T1.112.5; and
- 9.7.12.3 ISDNUP Performance, as specified in ANSI T1.113.5.
- 9.7.13 Interface Requirements
- 9.7.13.1 BellSouth shall offer the following SS7 Network Interconnection options to connect Adelphia or Adelphia-designated local or tandem switching systems or STPs to the BellSouth SS7 network:
- 9.7.13.1.1 A-link interface from Adelphia local or tandem switching systems; and
- 9.7.13.1.2 B-link interface from Adelphia STPs.
- 9.7.13.2 The Signaling Point of Interconnection (SPOI) for each link shall be located at a cross-connect element, such as a DSX-1, in the Central Office (CO) where the BellSouth STP is located. There shall be a DS1 or higher rate transport interface at each of the SPOIs. Each signaling link shall appear as a DS0 channel within the DS1 or higher rate interface. BellSouth shall offer higher rate DS1 signaling links for interconnecting Adelphia local switching systems or STPs with BellSouth STPs as soon as these

- become approved ANSI standards and available capabilities of BellSouth STPs. BellSouth and Adelphia will work jointly to establish mutually acceptable SPOI.
- 9.7.13.3 BellSouth CO shall provide intraoffice diversity between the SPOIs and the BellSouth STP, so that no single failure of intraoffice facilities or equipment shall cause the failure of both B-links in a layer connecting to a BellSouth STP. BellSouth and Adelphia will work jointly to establish mutually acceptable SPOI.
- 9.7.13.4 The protocol interface requirements for SS7 Network Interconnection include the MTP, ISDNUP, SCCP, and TCAP. These protocol interfaces shall conform to the applicable industry standard technical references.
- 9.7.13.5 BellSouth shall set message screening parameters to accept messages from Adelphia local or tandem switching systems destined to any signaling point in the BellSouth SS7 network with which the Adelphia switching system has a legitimate signaling relation.
- 9.7.13.6 SS7 Network Interconnection shall be equal to or better than all of the requirements for SS7 Network Interconnection set forth in the applicable industry standard technical references.

9.8 Rates

The prices that Adelphia shall pay to BellSouth for Services rendered pursuant to Section 9 are set forth in Exhibit D to this Attachment.

10. Operator Call Processing, Inward Operator Services and Directory Assistance Services

10.1 All of the negotiated rates, terms and conditions set forth in this Section pertain to the provision of Operator Call Processing, Inward Operator Services and Directory Assistance Services.

10.2 Operator Systems

10.2.1 Definition. Operator Systems is the Network Element that provides operator and automated call handling and billing, special services, end user telephone listings and optional call completion services. The Operator Systems, Network Element provides two types of functions: Operator Service functions and Directory Assistance Service functions, each of which are described in detail below.

10.3 Operator Service

10.3.1 Definition. Operator Service provides: (1) operator handling for call completion (for example, collect, third number billing, and manual credit card calls), (2) operator or automated assistance for billing after the end user has dialed the called number (for example, credit card calls); and (3) special services including but not limited to Busy Line Verification and Emergency Line Interrupt (ELI), Emergency Agency Call, Operator-assisted Directory Assistance, and Rate Quotes.

10.3.2 Requirements

10.3.2.1 When Adelphia requests BellSouth to provide Operator Services, the following requirements apply:

10.3.2.1.1 BellSouth shall complete 0+ and 0- dialed local calls.

10.3.2.1.2 BellSouth shall complete 0+ intraLATA toll calls.

10.3.2.1.3 BellSouth shall process calls that are billed to Adelphia end user's calling card that can be validated by BellSouth.

10.3.2.1.4 BellSouth shall complete person-to-person calls.

10.3.2.1.5 BellSouth shall complete collect calls.

10.3.2.1.6 BellSouth shall provide the capability for callers to bill to a third party and complete such calls.

10.3.2.1.7 BellSouth shall complete station-to-station calls.

- 10.3.2.1.8 BellSouth shall process emergency calls.
- 10.3.2.1.9 BellSouth shall process Busy Line Verify and Emergency Line Interrupt requests.
- 10.3.2.1.10 BellSouth shall process emergency call trace, as they do for their End users prior to the Effective Date. Call must originate from a 911 provider.
- 10.3.2.1.11 BellSouth shall process operator-assisted directory assistance calls.
- 10.3.2.1.12 BellSouth shall adhere to equal access requirements, providing Adelphia local end users the same IXC access as provided to BellSouth end users.
- 10.3.2.1.13 BellSouth shall exercise at least the same level of fraud control in providing Operator Service to Adelphia that BellSouth provides for its own operator service.
- 10.3.2.1.14 BellSouth shall perform Billed Number Screening when handling Collect, Person-to-Person, and Billed-to-Third-Party calls.
- 10.3.2.1.15 BellSouth shall direct customer account and other similar inquiries to the customer service center designated by Adelphia.
- 10.3.2.1.16 BellSouth shall provide a feed of customer call records in "EMI" format to Adelphia in accordance with CLEC ODUF standards specified in Attachment 7.

10.3.3 Interface Requirements

- 10.3.3.1 With respect to Operator Services for calls that originate on local switching capability provided by or on behalf of Adelphia, the interface requirements shall conform to the then current established system interface specifications for the platform used to provide Operator Service and the interface shall conform to industry standards.

10.4 **Directory Assistance Service**

- 10.4.1 Definition. Directory Assistance Service provides local end user telephone number listings with the option to complete the call at the callers direction separate and distinct from local switching.
- 10.4.2 Requirements
- 10.4.3 Directory Assistance Service shall provide up to two listing requests per call. If available and if requested by Adelphia's end user, BellSouth shall provide caller-optional directory assistance call completion service at rates contained in this Attachment to one of the provided listings, equal to that which BellSouth provides its end users. If not available, Adelphia may request such requirement pursuant to the Bona Fide Request/New Business Process as set forth in General Terms and Conditions.

10.4.4 Directory Assistance Service Updates

10.4.4.1 BellSouth shall update end user listings changes daily. These changes include:

10.4.4.1.1 New end user connections: BellSouth will provide service to Adelphia that is equal to the service it provides to itself and its end users;

10.4.4.1.2 End user disconnections: BellSouth will provide service to Adelphia that is equal to the service it provides to itself and its end users; and

10.4.4.1.3 End user address changes: BellSouth will provide service to Adelphia that is equal to the service it provides to itself and its end users;

10.4.4.1.4 These updates shall also be provided for non-listed and non-published numbers for use in emergencies.

10.4.5 Branding for Operator Call Processing and Directory Assistance

10.4.5.1 The BellSouth Operator Systems Branding Feature provides a definable announcement to Adelphia end users using Directory Assistance (DA)/Operator Call Processing (OCP) prior to placing them in queue or connecting them to an available operator or automated operator system. This feature allows Adelphia to have its calls custom branded with Adelphia's name on whose behalf BellSouth is providing Directory Assistance and/or Operator Call Processing. Rates for Custom Branding, Operator Call Process and Directory Assistance are set forth in this Attachment.

10.4.5.2 BellSouth offers four service levels of branding to Adelphia when ordering Directory Assistance and/or Operator Call Processing.

10.4.5.2.1 Service Level 1 - BellSouth Branding

10.4.5.2.2 Service Level 2 - Unbranded

10.4.5.2.3 Service Level 3 - Custom Branding

10.4.5.2.4 Service Level 4 - Self Branding (applicable only to Adelphia for Resale or use with an Unbundled Port when routing to an operator service provider other than BellSouth).

10.4.6 For Resellers and Use with an Unbundled Port

10.4.6.1 BellSouth Branding is the Default Service Level.

10.4.6.2 Unbranding, Custom Branding, and Self Branding require Adelphia to order selective routing for each originating BellSouth end office identified by Adelphia. Rates for Selective Routing are set forth in this Attachment.

- 10.4.6.3 Custom Branding and Self Branding require Adelphia to order dedicated trunking from each BellSouth end office identified by Adelphia, to either the BellSouth Traffic Operator Position System (TOPS) or Adelphia Operator Service Provider. Rates for trunks are set forth in Section 6 of BellSouth's intrastate access tariff.
- 10.4.6.4 Unbranding - Unbranded Directory Assistance and/or Operator Call Processing calls ride common trunk groups provisioned by BellSouth from those end offices identified by Adelphia to the BellSouth TOPS. These calls are routed to "No Announcement."
- 10.4.7 For Facilities Based Carriers
 - 10.4.7.1 All Service Levels require Adelphia to order dedicated trunking from their end office(s) point of interface to the BellSouth TOPS Switches. Rates for trunks are set forth in Section 6 of BellSouth's intrastate access tariffs.
 - 10.4.7.2 Customized Branding includes charges for the recording of the branding announcement and the loading of the audio units in each TOPS Switch, IVS and NAV equipment for which Adelphia requires service.
- 10.4.8 Directory Assistance customized branding uses:
 - 10.4.8.1 the recording of the name;
 - 10.4.8.2 the front-end loading of the Digital Recorded Announcement Machine (DRAM) in each TOPS switch.
- 10.4.9 Operator Call Processing customized branding uses:
 - 10.4.9.1 the recording of the name;
 - 10.4.9.2 the front-end loading of the DRAM in the TOPS Switch;
 - 10.4.9.3 the back-end loading in the audio units in the Automated Alternate Billing System (AABS) in the Interactive Voice Subsystem (IVS);
 - 10.4.9.4 the 0- automation loading for the audio units in the Enhanced Billing and Access Service (EBAS) in the Network Applications Vehicle (NAV).
 - 10.4.9.5 BellSouth will provide to Adelphia purchasing local BellSouth switching and reselling BellSouth local exchange service, selective routing of calls to a requested directory assistance services platform or operator services platform. Adelphia end users may use the same dialing arrangements as BellSouth end users, but obtain a Adelphia branded service.

10.5 Directory Assistance Database Service (DADS)

- 10.5.1 BellSouth shall make its Directory Assistance Database Service (DADS) available solely for the expressed purpose of providing Directory Assistance type services to Adelphia end users. The term “end user” denotes any entity which obtains Directory Assistance type services for its own use from a DADS customer. Directory Assistance type service is defined as Voice Directory Assistance (DA Operator assisted and Electronic Directory Assistance (Data System assisted)). Adelphia agrees that Directory Assistance Database Service (DADS) will not be used for any purpose which violates federal or state laws, statutes, regulatory orders or tariffs. Except for the permitted users, Adelphia agrees not to disclose DADS to others and shall provide due care in providing for the security and confidentiality of DADS. Further, Adelphia authorizes the inclusion of Adelphia Directory Assistance listings in the BellSouth Directory Assistance products.
- 10.5.2 BellSouth shall provide Adelphia initially with a base file of subscriber listings which reflect all listing change activity occurring since Adelphia’s most recent update via magnetic tape, and subsequently using electronic connectivity such as Network Data Mover to be developed mutually by Adelphia and BellSouth. Adelphia agrees to assume the costs associated with CONNECT: Direct™ connectivity, which will vary depending upon volume and mileage.
- 10.5.3 BellSouth will require approximately one month after receiving an order to prepare the Base File. BellSouth will provide daily updates which will reflect all listing change activity occurring since CLEC’s most recent update. BellSouth shall provide updates to Adelphia on a Business, Residence, or combined Business and Residence basis. Adelphia agrees that the updates shall be used solely to keep the information current. Delivery of Daily Updates will commence the day after Adelphia receives the Base File.
- 10.5.4 BellSouth is authorized to include Adelphia Directory Assistance Listing Information in its Directory Assistance Database Service (DADS). Any other use by BellSouth of Adelphia Directory Assistance Listing Information is not authorized and with the exception of a request for DADS, BellSouth shall refer any request for such information to Adelphia.
- 10.5.5 Rates for DADS are as set forth in this Attachment.

10.6 Direct Access to Directory Assistance Service

- 10.6.1 Direct Access to Directory Assistance Service (DADAS) will provide Adelphia’s directory assistance operators with the ability to search all available BellSouth’s subscriber listings using the Directory Assistance search format. Subscription to

- DADAS will allow Adelphia to utilize its own switch, operator workstations and optional audio subsystems.
- 10.6.2 BellSouth will provide DADAS from its DA location. Adelphia will access the DADAS system via a telephone company provided point of availability. Adelphia has the responsibility of providing the physical links required to connect to the point of availability. These facilities may be purchased from the telephone company as rates and charges billed separately from the charges associated with this offering.
- 10.6.3 A specified interface to each Adelphia subsystem will be provided by BellSouth. Interconnection between Adelphia's system and a specified BellSouth location will be pursuant to the use of Adelphia owned or Adelphia leased facilities and shall be appropriate sized based upon the volume of queries being generated by Adelphia.
- 10.6.4 The specifications for the three interfaces necessary for interconnection are available in the following documents:
- 10.6.4.1 DADAS to Subscriber Operator Position System—Northern Telecom Document CSI-2300-07; Universal Gateway/ Position Message Interface Format Specification;
- 10.6.4.2 DADAS to Subscriber Switch—Northern Telecom Document Q210-1 Version A107; NTDMS/CCIDAS System Application Protocol; and AT&T Document 250-900-535 Operator Services Position System Listing Service and Application Call Processing Data Link Interface Specification;
- 10.6.4.3 DADAS to Audio Subsystem (Optional)—Directory One Call Control to Audio Response Unit system interface specifications are available through Northern Telecom as a licensed access protocol—Northern Telecom Document 355-004424 and Gateway/Interactive Voice subsystem Protocol Specification.
- 10.6.5 Rates for DADAS are as set forth in this Attachment.
- 10.7 **Automatic Location Identification/Data Management System (ALI/DMS)**
- 10.7.1 The ALI/DMS Database contains end user information (including name, address, telephone information, and sometimes special information from the local service provider or end user) used to determine to which Public Safety Answering Point (PSAP) to route the call. The ALI/DMS database is used to provide more routing flexibility for E911 calls than Basic 911. BellSouth shall provide the Emergency Services Database in accordance with the following:
- 10.7.2 Technical Requirements
- 10.7.2.1 BellSouth shall offer Adelphia a data link to the ALI/DMS database or permit Adelphia to provide its own data link to the ALI/DMS database. BellSouth shall

provide error reports from the ALI/DMS database to Adelphia immediately after Adelphia inputs information into the ALI/DMS database. Alternately, Adelphia may utilize BellSouth, to enter end user information into the data base on a demand basis, and validate end user information on a demand basis.

10.7.2.2 The ALI/DMS database shall contain the following end user information:

10.7.2.2.1 Name;

10.7.2.2.2 Address;

10.7.2.2.3 Telephone number; and

10.7.2.2.4 Other information as appropriate (e.g., whether a end user is blind or deaf or has another disability).

10.7.2.3 When BellSouth is responsible for administering the ALI/DMS database in its entirety, ported number NXXs entries for the ported numbers should be maintained unless Adelphia requests otherwise and shall be updated if Adelphia requests, provided Adelphia supplies BellSouth with the updates.

10.7.2.4 When Remote Call Forwarding (RCF) is used to provide number portability to the local end user and a remark or other appropriate field information is available in the database, the shadow or "forwarded-to" number and an indication that the number is ported shall be added to the customer record.

10.7.2.5 If BellSouth is responsible for configuring PSAP features (for cases when the PSAP or BellSouth supports an ISDN interface) it shall ensure that CLASS Automatic Recall (Call Return) is not used to call back to the ported number. Although BellSouth currently does not have ISDN interface, BellSouth agrees to comply with this requirement once ISDN interfaces are in place.

10.7.3 Interface Requirements

The interface between the E911 Switch or Tandem and the ALI/DMS database for Adelphia end users shall meet industry standards.

10.8 Rates

The prices that Adelphia shall pay to BellSouth for Services rendered pursuant to Section 10 are set forth in Exhibit D to this Attachment.

11. Calling Name (CNAM) Database Service

11.1 All of the negotiated rates, terms and conditions set forth in this Section pertain to the provision of CNAM.

- 11.2 The Agreement for Calling Name (CNAM) with standard pricing is included as Exhibit B to this Attachment. Adelphia must provide to its account manager a written request with a requested activation date to activate this service. If Adelphia is interested in requesting CNAM with volume and term pricing, Adelphia must contact its account manager to request a separate CNAM volume and term Agreement.
- 11.3 SCPs/Databases shall be equal to or better than all of the requirements for SCPs/Databases set forth in the applicable industry standard technical references.
- 11.4 Service Creation Environment and Service Management System (SCE/SMS) Advanced Intelligent Network (AIN) Access**
- 11.4.1 BellSouth's Service Creation Environment and Service Management System (SCE/SMS) Advanced Intelligent Network (AIN) Access shall provide Adelphia the capability that will allow Adelphia and other third parties to create service applications in a BellSouth Service Creation Environment and deploy those applications in a BellSouth SMS to a BellSouth SCP. The third party service applications interact with AIN triggers provisioned on a BellSouth SSP.
- 11.4.2 BellSouth's SCE/SMS AIN Access shall provide access to SCE hardware, software, testing and technical support (e.g., help desk, system administrator) resources available to Adelphia. Scheduling procedures shall provide Adelphia equivalent priority to these resources.
- 11.4.2 BellSouth SCP shall partition and protect Adelphia service logic and data from unauthorized access, execution or other types of compromise.
- 11.4.3 When Adelphia selects SCE/SMS AIN Access, BellSouth shall provide training, documentation, and technical support to enable Adelphia to use BellSouth's SCE/SMS AIN Access to create and administer applications. Training, documentation, and technical support will address use of SCE and SMS access and administrative functions, but will not include support for the creation of a specific service application.
- 11.4.4 When Adelphia selects SCE/SMS AIN Access, BellSouth shall provide for a secure, controlled access environment in association with its internal use of AIN components. Adelphia access will be provided via remote data connection (e.g., dial-in, ISDN).
- 11.4.5 When Adelphia selects SCE/SMS AIN Access, BellSouth shall allow Adelphia to download data forms and/or tables to BellSouth SCP via BellSouth SMS without intervention from BellSouth (e.g., service customization and end user subscription).

11.5 Rates

The prices that Adelphia shall pay to BellSouth for Services rendered pursuant to Section 11 are set forth in Exhibit D to this Attachment.

12. Basic 911 and E911

12.1 All of the negotiated terms and conditions set forth in this Section pertain to the provision of Basic 911 and E911.

12.2 If Adelphia orders network elements and other services, then Adelphia is also responsible for providing E911 to its end users. BellSouth agrees to offer access to the 911/E911 network pursuant to the following terms and conditions set forth in this Attachment.

12.3 Definition

12.4 Basic 911 and E911 is an additional requirement that provides a caller access to the applicable emergency service bureau by dialing a 3-digit universal telephone number (911).

12.5 Requirements

12.5.1 Basic 911 Service Provisioning. For Basic 911 service, BellSouth will provide to Adelphia a list consisting of each municipality that subscribes to Basic 911 service. The list will also provide, if known, the E911 conversion date for each municipality and, for network routing purposes, a ten-digit directory number representing the appropriate emergency answering position for each municipality subscribing to 911. Adelphia will be required to arrange to accept 911 calls from its end users in municipalities that subscribe to Basic 911 service and translate the 911 call to the appropriate 10-digit directory number as stated on the list provided by BellSouth. Adelphia will be required to route that call to BellSouth at the appropriate tandem or end office. When a municipality converts to E911 service, Adelphia will be required to discontinue the Basic 911 procedures and being using E911 procedures.

12.5.2 E911 Service Provisioning. For E911 service, Adelphia will be required to install a minimum of two dedicated trunks originating from the Adelphia serving wire center and terminating to the appropriate E911 tandem. The dedicated trunks shall be, at a minimum, DS-0 level trunks configured either as a 2-wire analog interface or as part of a digital (1.544 Mb/s) interface. Either configuration shall use CAMA-type signaling with multifrequency (“MF”) pulsing that will deliver automatic number identification (“ANI”) with the voice portion of the call. If the user interface is digital, MF pulses, as well as other AC signals, shall be encoded per the u-255 Law convention. Adelphia will be required to provide BellSouth daily updates to the E911 database. Adelphia will be required to forward 911 calls to the appropriate E911 tandem, along with ANI, based upon the current E911 end office to tandem homing arrangement as provided by BellSouth. If the E911 tandem trunks are not available, Adelphia will be required to route the call to a designated 7-digit local number residing in the appropriate Public

- Service Answering Point (“PSAP”). This call will be transported over BellSouth’s interoffice network and will not carry the ANI of the calling party. Adelphia shall be responsible for providing BellSouth with complete and accurate data for submission to the 911/E911 database for the purpose of providing 911/E911 to its end users.
- 12.5.3 Rates. Charges for 911/E911 service are borne by the municipality purchasing the service. BellSouth will impose no charge on Adelphia beyond applicable charges for BellSouth trunking arrangements.
- 12.5.4 Basic 911 and E911 functions provided to Adelphia shall be at least at parity with the support and services that BellSouth provides to its end users for such similar functionality.
- 12.5.5 Detailed Practices and Procedures. The detailed practices and procedures contained in the E911 Local Exchange Carrier Guide For Facility-Based Providers as amended from time to time during the term of this Agreement will determine the appropriate practices and procedures for BellSouth and Adelphia to follow in providing 911/E911 services.

13. True-Up

This section applies only to Tennessee and other rates that are interim or expressly subject to true-up under this attachment.

- 13.1 The interim prices for Network Elements and Other Services and Local Interconnection shall be subject to true-up according to the following procedures:
- 13.2 The interim prices shall be trued-up, either up or down, based on final prices determined either by further agreement between the Parties, or by a final order (including any appeals) of the Commission which final order meets the criteria of (3) below. The Parties shall implement the true-up by comparing the actual volumes and demand for each item, together with interim prices for each item, with the final prices determined for each item. Each Party shall keep its own records upon which the true-up can be based, and any final payment from one Party to the other shall be in an amount agreed upon by the Parties based on such records. In the event of any disagreement as between the records or the Parties regarding the amount of such true-up, the Parties agree that the body having jurisdiction over the matter shall be called upon to resolve such differences, or the Parties may mutually agree to submit the matter to the Dispute Resolution process in accordance with the provisions of Section 16 of the General Terms and Conditions and Attachment 1 of the Agreement.

- 13.3 The Parties may continue to negotiate toward final prices, but in the event that no such Agreement is reached within nine (9) months, either Party may petition the Commission to resolve such disputes and to determine final prices for each item. Alternatively, upon mutual agreement, the Parties may submit the matter to the Dispute Resolution Process set forth in Section 16 of the General Terms and Conditions and Attachment 1 of the Agreement, so long as they file the resulting Agreement with the Commission as a “negotiated Agreement” under Section 252(e) of the Act.
- 13.4 A final order of the Commission that forms the basis of a true-up shall be the final order as to prices based on appropriate cost studies, or potentially may be a final order in any other Commission proceeding which meets the following criteria:
- (a) BellSouth and Adelphia are entitled to be a full Party to the proceeding;
 - (b) It shall apply the provisions of the federal Telecommunications Act of 1996, including but not limited to Section 252(d)(1) (which contains pricing standards) and all then-effective implementing rules and regulations; and,
 - (c) In the case of loops only it shall include as an issue the geographic deaveraging of network element and other services prices, which deaveraged prices, if any are required by said final order, shall form the basis of any true-up.

EXHIBIT A**LINE INFORMATION DATA BASE (LIDB)
STORAGE AGREEMENT****I. SCOPE**

- A. This Agreement sets forth the terms and conditions pursuant to which BellSouth agrees to store in its LIDB certain information at the request of Adelphia and pursuant to which BellSouth, its LIDB customers and Adelphia shall have access to such information. Adelphia understands that BellSouth provides access to information in its LIDB to various telecommunications service providers pursuant to applicable tariffs and agrees that information stored at the request of Adelphia, pursuant to this Agreement, shall be available to those telecommunications service providers. The terms and conditions contained in the attached Addendum(s) are hereby made a part of this Agreement as if fully incorporated herein.
- B. LIDB is accessed for the following purposes:
1. Billed Number Screening
 2. Calling Card Validation
 3. Fraud Control
- C. BellSouth will provide seven days per week, 24-hours per day, fraud monitoring on Calling Cards, bill-to-third and collect calls made to numbers in BellSouth's LIDB, provided that such information is included in the LIDB query. BellSouth will establish fraud alert thresholds and will notify Adelphia of fraud alerts so that Adelphia may take action it deems appropriate. Adelphia understands and agrees BellSouth will administer all data stored in the LIDB, including the data provided by Adelphia pursuant to this Agreement, in the same manner as BellSouth's data for BellSouth's end user customers. BellSouth shall not be responsible to Adelphia for any lost revenue which may result from BellSouth's administration of the LIDB pursuant to its established practices and procedures as they exist and as they may be changed by BellSouth in its sole discretion from time to time.

Adelphia understands that BellSouth currently has in effect numerous billing and collection agreements with various interexchange carriers and billing clearing houses. Adelphia further understands that these billing and collection customers of BellSouth query BellSouth's LIDB to determine whether to accept various billing options from end users. Additionally, Adelphia understands that presently BellSouth has no method to differentiate between BellSouth's own billing and line data in the LIDB and such data which it includes in the LIDB on Adelphia's behalf pursuant to this Agreement. Therefore, until such time as BellSouth can and does implement in its LIDB and its supporting systems the means to differentiate Adelphia's data from BellSouth's data

and the Parties to this Agreement execute appropriate amendments hereto, the following terms and conditions shall apply:

- (a) Adelphia agrees that it will accept responsibility for telecommunications services billed by BellSouth for its billing and collection customers for Adelphia's end user accounts which are resident in LIDB pursuant to this Agreement. Adelphia authorizes BellSouth to place such charges on Adelphia's bill from BellSouth and agrees that it shall pay all such charges. Charges for which Adelphia hereby takes responsibility include, but are not limited to, collect and third number calls.
- (b) Charges for such services shall appear on a separate BellSouth bill page identified with the name of the entity for which BellSouth is billing the charge.
- (c) Adelphia shall have the responsibility to render a billing statement to its end users for these charges, but Adelphia's obligation to pay BellSouth for the charges billed shall be independent of whether Adelphia is able or not to collect from Adelphia's end users.
- (d) BellSouth shall not become involved in any disputes between Adelphia and the entities for which BellSouth performs billing and collection. BellSouth will not issue adjustments for charges billed on behalf of an entity to Adelphia. It shall be the responsibility of Adelphia and the other entity to negotiate and arrange for any appropriate adjustments.

II. TERM

This Agreement will be effective as of _____, and will continue in effect for one year, and thereafter may be continued until terminated by either Party upon thirty (30) days written notice to the other Party.

III. FEES FOR SERVICE AND TAXES

- A. Adelphia will not be charged a fee for storage services provided by BellSouth to Adelphia, as described in Section I of this Agreement.
- B. Sales, use and all other taxes (excluding taxes on BellSouth's income) determined by BellSouth or any taxing authority to be due to any federal, state or local taxing jurisdiction with respect to the provision of the service set forth herein will be paid by Adelphia. Adelphia shall have the right to have BellSouth contest with the imposing jurisdiction, at Adelphia's expense, any such taxes that Adelphia deems are improperly levied.

IV. INDEMNIFICATION

To the extent not prohibited by law, each Party will indemnify the other and hold the other harmless against any loss, cost, claim, injury, or liability relating to or arising out of negligence or willful misconduct by the indemnifying Party or its agents or contractors in connection with the indemnifying Party's provision of services, provided, however, that any indemnity for any loss, cost, claim, injury or liability arising out of or relating to errors or omissions in the provision of services under this Agreement shall be limited as otherwise specified in this Agreement. The indemnifying Party under this Section agrees to defend any suit brought against the other Party for any such loss, cost, claim, injury or liability. The indemnified Party agrees to notify the other Party promptly, in writing, of any written claims, lawsuits, or demands for which the other Party is responsible under this Section and to cooperate in every reasonable way to facilitate defense or settlement of claims. The indemnifying Party shall not be liable under this Section for settlement by the indemnified Party of any claim, lawsuit, or demand unless the defense of the claim, lawsuit, or demand has been tendered to it in writing and the indemnifying Party has unreasonably failed to assume such defense.

V. LIMITATION OF LIABILITY

Neither Party shall be liable to the other Party for any lost profits or revenues or for any indirect, incidental or consequential damages incurred by the other Party arising from this Agreement or the services performed or not performed hereunder, regardless of the cause of such loss or damage.

VI. MISCELLANEOUS

A. It is understood and agreed to by the Parties that BellSouth may provide similar services to other companies.

All terms, conditions and operations under this Agreement shall be performed in accordance with, and subject to, all applicable local, state or federal legal and regulatory tariffs, rulings, and other requirements of the federal courts, the U. S. Department of Justice and state and federal regulatory agencies. Nothing in this Agreement shall be construed to cause either Party to violate any such legal or regulatory requirement and either Party's obligation to perform shall be subject to all such requirements.

C. Adelphia agrees to submit to BellSouth all advertising, sales promotion, press releases, and other publicity matters relating to this Agreement wherein BellSouth's corporate or trade names, logos, trademarks or service marks or those of BellSouth's affiliated companies are mentioned or language from which the connection of said names or trademarks therewith may be inferred or implied; and Adelphia further agrees not to publish or use advertising, sales promotions, press releases, or publicity matters without BellSouth's prior written approval.

- D. This Agreement constitutes the entire Agreement between Adelphia and BellSouth which supersedes all prior Agreements or contracts, oral or written representations, statements, negotiations, understandings, proposals and undertakings with respect to the subject matter hereof.
- E. Except as expressly provided in this Agreement, if any part of this Agreement is held or construed to be invalid or unenforceable, the validity of any other Section of this Agreement shall remain in full force and effect to the extent permissible or appropriate in furtherance of the intent of this Agreement.
- F. Neither Party shall be held liable for any delay or failure in performance of any part of this Agreement for any cause beyond its control and without its fault or negligence, such as acts of God, acts of civil or military authority, government regulations, embargoes, epidemics, war, terrorist acts, riots, insurrections, fires, explosions, earthquakes, nuclear accidents, floods, strikes, power blackouts, volcanic action, other major environmental disturbances, unusually severe weather conditions, inability to secure products or services of other persons or transportation facilities, or acts or omissions of transportation common carriers.
- G. This Agreement shall be deemed to be a contract made under the laws of the State of Georgia, and the construction, interpretation and performance of this Agreement and all transactions hereunder shall be governed by the domestic law of such State.

**FACILITIES BASED ADDENDUM
TO LINE INFORMATION DATA BASE (LIDB)
STORAGE AGREEMENT**

This is a Facilities Based Addendum to the Line Information Data Base Storage Agreement dated _____, between BellSouth Telecommunications, Inc. (“BellSouth”), and _____ (“Adelphia”), effective the ____ day of _____, _____.

I. GENERAL

This Addendum sets forth the terms and conditions for Adelphia’s provision of billing number information to BellSouth for inclusion in BellSouth’s LIDB. BellSouth will store in its LIDB the billing number information provided by Adelphia, and BellSouth will provide responses to on-line, call-by-call queries to this information for purposes specified in Section I.B. of the Agreement.

II. DEFINITIONS

- A. Billing number - a number that Adelphia creates for the purpose of identifying an account liable for charges. This number may be a line or a special billing number.
- B. Line number - a ten digit number that identifies a telephone line administered by Adelphia.
- C. Special billing number - a ten digit number that identifies a billing account established by Adelphia.
- D. Calling Card number - a billing number plus PIN number.
- E. PIN number - a four digit security code assigned by Adelphia which is added to a billing number to compose a fourteen digit calling card number.
- F. Toll billing exception indicator - associated with a billing number to indicate that it is considered invalid for billing of collect calls or third number calls or both, by Adelphia.
- G. Billed Number Screening - refers to the activity of determining whether a toll billing exception indicator is present for a particular billing number.

- H. Calling Card Validation - refers to the activity of determining whether a particular calling card number exists as stated or otherwise provided by a caller.
- I. Billing number information - information about billing number, Calling Card number and toll billing exception indicator provided to BellSouth by Adelphia.

III. RESPONSIBILITIES OF PARTIES

- A. Adelphia will provide its billing number information to BellSouth's LIDB each business day by a method that has been mutually agreed upon by both Parties.
- B. BellSouth will store in its LIDB the billing number information provided by Adelphia. Under normal operating conditions, BellSouth shall include Adelphia's billing number information in its LIDB no later than two business days following BellSouth's receipt of such billing number information, provided that BellSouth shall not be held responsible for any delay or failure in performance to the extent such delay or failure is caused by circumstances or conditions beyond BellSouth's reasonable control. BellSouth will store in its LIDB an unlimited volume of Adelphia's working telephone numbers.
- C. BellSouth will provide responses to on-line, call-by-call queries to the stored information for the specific purposes listed in the next paragraph.
- D. BellSouth is authorized to use the billing number information provided by Adelphia to perform the following functions for authorized users on an on-line basis:
 - 1. Validate a 14 digit Calling Card number where the first 10 digits are a line number or special billing number assigned by Adelphia, and where the last four digits (PIN) are a security code assigned by Adelphia.
 - 2. Determine whether Adelphia or the subscriber has identified the billing number as one which should not be billed for collect or third number calls, or both.
- E. Adelphia will provide its own billing number information to BellSouth for storage and to be used for Billed Number Screening and Calling Card Validation. Adelphia will arrange and pay for transport of updates to BellSouth.

IV. COMPLIANCE

Unless expressly authorized in writing by Adelphia, all billing number information provided pursuant to this Addendum shall be used for no purposes other than those set forth in this Addendum.

EXHIBIT B

CALLING NAME DELIVERY (CNAM) DATABASE SERVICES

1. Definitions

For the purpose of this Attachment, the following terms shall be defined as:

CALLING NAME DELIVERY DATABASE SERVICE (CNAM) - The ability to associate a name with the calling party number, allowing the end user subscriber (to which a call is being terminated) to view the calling party's name before the call is answered. This service also provides Adelphia the opportunity to load and store its subscriber names in the BellSouth CNAM SCPs.

CALLING PARTY NUMBER (CPN) - The number of the calling party that is delivered to the terminating switch using common channel signaling system 7 (CCS7) technology, and that is contained in the Initial Address Message (IAM) portion of the CCS7 call setup.

COMMON CHANNEL SIGNALING SYSTEM 7 (CCS7) - A network signaling technology in which all signaling information between two or more nodes is transmitted over high-speed data links, rather than over voice circuits.

SERVICE CONTROL POINTs (SCPs) - The real-time data base systems that contain the names to be provided in response to queries received from CNAM SSPs.

SERVICE MANAGEMENT SYSTEM (SMS) - The main operations support system of CNAM DATABASE SERVICE. CNAM records are loaded into the SMS, which in turn downloads into the CNAM SCP.

SERVICE SWITCHING POINTs (SSPs) - Features of computerized switches in the telephone network that determine that a terminating line has subscribed to CNAM service, and then communicate with CNAM SCPs in order to provide the name associated with the calling party number.

SUBSYSTEM NUMBER (SSN) - The address used in the Signaling Connection Control Part (SCCP) layer of the SS7 protocol to designate an application at an end signaling point. A SSN for CNAM at the end office designates the CNAM application within the end office. BellSouth uses the CNAM SSN of 232.

2. Attachment

2.1 This Attachment contains the terms and conditions where BellSouth will provide to the Adelphia access to the BellSouth CNAM SCP for query or record storage purposes.

Adelphia shall submit to BellSouth a notice of its intent to access and utilize BellSouth CNAM Database Services pursuant to the terms and conditions of this Attachment. Said notice shall be in writing, no less than 60 days prior to Adelphia's access to BellSouth's CNAM Database Services and shall be addressed to Adelphia's Account Manager.

3. Physical Connection and Compensation

3.1 BellSouth's provision of CNAM Database Services to Adelphia requires interconnection from Adelphia to BellSouth CNAM Service Control Points (SCPs). Such interconnections shall be established pursuant to Attachment 3 of this Agreement. The appropriate charge for access to and use of the BellSouth CNAM Database service shall be as set forth in this Attachment.

3.2 In order to formulate a CNAM query to be sent to the BellSouth CNAM SCP, Adelphia shall provide its own CNAM SSP. Adelphia's CNAM SSPs must be compliant with TR-NWT-001188, "CLASS Calling Name Delivery Generic Requirements".

3.3 If Adelphia elects to access the BellSouth CNAM SCP via a third party CCS7 transport provider, the third party CCS7 provider shall interconnect with the BellSouth CCS7 network according to BellSouth's Common Channel Signaling Interconnection Guidelines and Telcordia (formerly BellCore)'s CCS Network Interface Specification document, TR-TSV-000905. In addition, the third party provider shall establish CCS7 interconnection at the BellSouth Local Signal Transfer Points (LSTPs) serving the BellSouth CNAM SCPs that Adelphia desires to query.

3.4 Out-Of-Region Customers

If the customer queries the BellSouth CNAM SCP via a third party national SS7 transport provider, the third party SS7 provider shall interconnect with the BellSouth CCS7 network according to BellSouth's Common Channel Signaling Interconnection Guidelines and Telcordia's (formerly BellCore's) CCS Network Interface Specification document, TR-TSV-000905. In addition, the third party provider shall establish SS7 interconnection at one or more of the BellSouth Gateway Signal Transfer Points (STPs). The payment of all costs associated with the transport of SS7 signals via a third party will be established by mutual agreement of the Parties in writing and shall, by this reference become an integral part of this Agreement.

4. CNAM Record Initial Load and Updates

4.1 The mechanism to be used by Adelphia for initial CNAM record load and/or updates shall be determined by mutual agreement. The initial load and all updates shall be provided by Adelphia in the BellSouth specified format and shall contain records for every working telephone number that can originate phone calls. It is

the responsibility of Adelphia to provide accurate information to BellSouth on a current basis.

- 4.2 Updates to the SMS shall occur no less than once a week, reflect service order activity affecting either name or telephone number, and involve only record additions, deletions or changes.
- 4.3 Adelphia CNAM records provided for storage in the BellSouth CNAM SCP shall be available, on a SCP query basis only, to all Parties querying the BellSouth CNAM SCP. Further, CNAM service shall be provided by each Party consistent with state and/or federal regulation.

EXHIBIT C

CLEC/BellSouth Line Sharing Jointly Developed

Rules for Splitter Allocation

BellSouth is unable to obtain a sufficient number of splitters for placement in all central offices requested by competitive local exchange carriers (“CLECs”) by June 6, 2000. As a result of the current shortage of splitters, CLECs and BellSouth developed the following rules for splitter allocation. These rules shall apply until such time as those CLECs participating in the creation of the rules agree that the regular splitter installation rules should apply.

1. There shall be a single CLEC priority list of central offices that shall consist of the Georgia CLEC priority list combined with the priority list from the other states in BellSouth’s nine-state region (the “Priority List”). This priority list shall be used for filling orders; it shall determine the order in which splitters will be deployed in those central offices for which splitters have been ordered. Georgia central offices (CO) will have priority over other state’s COs.
2. During the allocation period, a CLEC may order 24 ports or 96 ports. In either event, BellSouth shall install a 96 port splitter in accordance with the Priority List. However, during the allocation period, in the event a CLEC orders 96 ports, BellSouth will only allocate 24 ports of the 96 port splitter to the first CLEC that orders a splitter for that central office, thus creating a backlog of 72 ports that have already been ordered by that CLEC (“Backlog”). In the event of a Backlog, BellSouth will charge CLEC a monthly recurring charge appropriate for the number of ports allocated to CLEC. In addition, if CLEC requested a 96 port splitter, it shall pay a non-recurring charge for a 96 port splitter, but shall pay no non-recurring charges when additional ports are added to alleviate the Backlog.
3. BellSouth will allocate, on a first-come/first-served basis, the remaining 72 ports of the splitter (in blocks of 24 ports) to the other CLECs that place an order for a splitter at that same central office.

Orders Submitted by April 26, 2000 with Due Date of June 6, 2000 or Sooner

4. A firm order for a splitter issued to the BellSouth Complex Resale Support Group (CRSG) on or by April 26, 2000, with due date of June 6, 2000, or sooner, will be given priority over orders received after April 26, 2000. Orders for the first 200 splitters received prior to April 26, 2000, will be installed on or before June 5, 2000, and shall be

installed in accordance with the priority list. The first 25 splitter orders shall be installed no later than May 22, 2000.

5. In the event CLECs submit to BellSouth more than 200 splitter orders on or before April 26, 2000, BellSouth shall install fifty (50) splitters a week each week after June 5, 2000.
6. In the event there are more than four (4) orders submitted on or before April 26, 2000, for a splitter at a particular central office, a second splitter will be installed at that central office in accordance with the Priority List.
7. Backlogs associated with orders submitted on or before April 26, 2000 will be fulfilled in their entirety before any orders received after April 26, 2000 are worked. In fulfilling a Backlog, the CLEC's additional ports may not be on the same shelf as the initial 24 ports.

Orders Received after April 26, 2000

8. Irrespective of the Priority List, no orders received after April 26, 2000, will be worked until after all orders received on or before April 26, 2000 have been completed.
9. Once all orders received on or before April 26, 2000, have been worked in their entirety, orders received after April 26, 2000, will have a minimum interval of forty-two (42) calendar days from date of receipt.

Orders Submitted with Due Dates After June 6, 2000

10. Any order submitted on or before April 26, 2000, with a due date of after June 6, 2000, will be completed according to the due date provided there is available inventory and all orders with a due date of June 6, 2000 or earlier have been completed.

Georgia Rating/Ranking of Central Offices for Linesharing**March 9, 2000****Covad, Rhythms, NorthPoint, New
Edge****CLLI****Combined Ranking**

| | |
|----------|----|
| MRTTGAMA | 1 |
| RSWLGAMA | 2 |
| ATLNGABU | 3 |
| ATLNGAPP | 4 |
| DLTHGAHS | 5 |
| ATLNGASS | 6 |
| CHMBGAMA | 7 |
| AGSTGAAU | 8 |
| LRVLGAOS | 9 |
| MRTTGAEA | 10 |
| SMYRGAMA | 11 |
| LLBNGAMA | 12 |
| WDSTGACR | 13 |
| ATHNGAMA | 14 |
| AGSTGAFL | 15 |
| AGSTGATH | 16 |
| JNBOGAMA | 17 |
| NRCRGAMA | 18 |
| ATLNGATH | 19 |
| ALPRGAMA | 20 |
| DNWDGAMA | 21 |
| CMNGGAMA | 22 |
| AGSTGAMT | 23 |
| ALBYGAMA | 24 |
| GSVLGAMA | 25 |
| SNLVGAMA | 26 |
| ATLNGAIC | 27 |
| ATLNGAEP | 28 |
| TUKRGAMA | 29 |
| ROMEGATL | 30 |
| VLDSGAMA | 31 |
| MACNGAMT | 32 |
| ASTLGAMA | 33 |
| SMYRGAPF | 34 |

| | |
|-----------|----|
| DGVLGAMA | 35 |
| ATLNGAEL | 36 |
| SNMTGALR | 37 |
| CNYRGAMA | 38 |
| MACNGAVN | 39 |
| WRRBGAMA | 40 |
| NWNINGAMA | 41 |
| ATLNGAWD | 42 |
| GRFNGAMA | 43 |
| PANLGAMA | 44 |
| BUFRGABH | 45 |
| ATLNGACD | 46 |
| MACNGAGP | 47 |
| SVNHGABS | 48 |
| ATLNGACS | 49 |
| PTCYGAMA | 50 |
| RVDLGAMA | 51 |
| STBRGANH | 52 |
| MCDNGAGS | 53 |
| ATLNGAWE | 54 |
| SVNHGADE | 55 |
| SVNHGAWB | 56 |
| ATLNGAGR | 57 |
| ATLNGAAD | 58 |
| CRVLGAMA | 59 |
| ACWOGAMA | 60 |
| ATLNGABH | 61 |
| FYVLGASG | 62 |
| SVNHGAGC | 63 |
| SVNHGAWI | 64 |
| ATLNGAFP | 65 |
| ATLNGAHR | 66 |
| PWSPGAAS | 67 |
| CRTNGAMA | 68 |
| ATLNGALA | 69 |
| MRRWGAMA | 70 |
| CLMBGAMT | 71 |
| CLMBGAMW | 72 |
| LTHNGAJS | 73 |
| CVTNGAMT | 74 |
| DLLSGAES | 75 |
| FRBNGAEB | 76 |

| | |
|----------|----|
| CLMBGABV | 77 |
| BRWKGAMA | 78 |
| ATLNGAQS | 79 |
| CNTNGAXB | 80 |
| LGVLGACS | 81 |
| SSISGAES | 81 |

BellSouth Central Offices (All states excluding GA)

| Ref. # | CLLI | State | Combined CLEC Rank |
|---------------|-------------|--------------|---------------------------|
| 312 | PRRNFLMA | FL | 1 |
| 1330 | MMPHTNBA | TN | 2 |
| 1362 | NSVLTNMT | TN | 3 |
| 202 | GSVLFLNW | FL | 4 |
| 1 | ALBSALMA | AL | 5 |
| 13 | BRHMALCH | AL | 6 |
| 268 | MLBRFLMA | FL | 7 |
| 1337 | MMPHTNMA | TN | 8 |
| 285 | ORLDFLAP | FL | 9 |
| 1335 | MMPHTNGT | TN | 10 |
| 208 | HLWDFLPE | FL | 11 |
| 289 | ORLDFLPH | FL | 12 |
| 1333 | MMPHTNEL | TN | 13 |
| 324 | STRTFLMA | FL | 14 |
| 14 | BRHMALCP | AL | 15 |
| 15 | BRHMALEL | AL | 16 |
| 1141 | CLMASCSN | SC | 17 |
| 1240 | CHTGTNNS | TN | 18 |
| 1339 | MMPHTNOA | TN | 19 |
| 1073 | RLGHNCSE | NC | 20 |
| 299 | PMBHFLCS | FL | 21 |
| 698 | NWORLASW | LA | 22 |
| 1354 | NSVLTNBW | TN | 23 |
| 1309 | KNVLTNMA | TN | 24 |
| 16 | BRHMALEN | AL | 25 |
| 17 | BRHMALEW | AL | 26 |
| 1345 | MRBOTNMA | TN | 27 |
| 1364 | NSVLTNUN | TN | 28 |
| 623 | KNNRLABR | LA | 29 |
| 984 | CARYNCCE | NC | 30 |
| 333 | WPBHFLGA | FL | 31 |
| 1356 | NSVLTNCH | TN | 32 |
| 1363 | NSVLTNST | TN | 33 |
| 429 | LSVLKYAP | KY | 34 |
| 20 | BRHMALHW | AL | 35 |
| 21 | BRHMALMT | AL | 36 |

BellSouth Central Offices (All states excluding GA)

| Ref. # | CLLI | State | Combined CLEC Rank |
|---------------|-------------|--------------|---------------------------|
| 638 | LFYTLAMA | LA | 37 |
| 1306 | KNTNTNMA | TN | 38 |
| 693 | NWORLAMT | LA | 39 |
| 149 | BCRTFLMA | FL | 40 |
| 150 | BCRTFLSA | FL | 41 |
| 1340 | MMPHTNSL | TN | 42 |
| 1338 | MMPHTNMT | TN | 43 |
| 307 | PNSCFLFP | FL | 44 |
| 22 | BRHMALOM | AL | 45 |
| 23 | BRHMALOX | AL | 46 |
| 176 | DYBHFLMA | FL | 47 |
| 1352 | NSVLTNAP | TN | 48 |
| 1332 | MMPHTNCT | TN | 49 |
| 334 | WPBHFLGR | FL | 50 |
| 249 | MIAMFLCA | FL | 51 |
| 732 | SLIDLAMA | LA | 52 |
| 1307 | KNVLTNBE | TN | 53 |
| 64 | MTGMALDA | AL | 54 |
| 24 | BRHMALRC | AL | 55 |
| 26 | BRHMALVA | AL | 56 |
| 196 | FTPRFLMA | FL | 57 |
| 1272 | FKLNTNMA | TN | 58 |
| 695 | NWORLARV | LA | 59 |
| 1019 | GNBONCAS | NC | 60 |
| 1068 | RLGHNCGL | NC | 61 |
| 692 | NWORLAMR | LA | 62 |
| 1310 | KNVLTNWH | TN | 63 |
| 179 | DYBHFLPO | FL | 64 |
| 34 | BSMRALMA | AL | 65 |
| 148 | BCRTFLBT | FL | 66 |
| 233 | JPTRFLMA | FL | 67 |
| 1357 | NSVLTNDO | TN | 68 |
| 697 | NWORLASK | LA | 69 |
| 189 | FTLDFLJA | FL | 70 |
| 262 | MIAMFLRR | FL | 71 |
| 288 | ORLDFLPC | FL | 72 |
| 1361 | NSVLTNMC | TN | 73 |

BellSouth Central Offices (All states excluding GA)

| Ref. # | CLLI | State | Combined CLEC Rank |
|---------------|-------------|--------------|---------------------------|
| 667 | MONRLAMA | LA | 74 |
| 664 | MNFDLAMA | LA | 75 |
| 157 | BYBHFLMA | FL | 76 |
| 170 | DLBHFLKP | FL | 77 |
| 554 | BTRGLAGW | LA | 78 |
| 1237 | CHTGTNDT | TN | 79 |
| 232 | JCVLFLWC | FL | 80 |
| 253 | MIAMFLHL | FL | 81 |
| 988 | CHRLNCCE | NC | 82 |
| 431 | LSVLKYBR | KY | 83 |
| 1353 | NSVLTNBV | TN | 84 |
| 1158 | FLRNSCMA | SC | 85 |
| 171 | DLBHFLMA | FL | 86 |
| 174 | DRBHFLMA | FL | 87 |
| 1323 | MAVLTNMA | TN | 88 |
| 1358 | NSVLTNGH | TN | 89 |
| 230 | JCVLFLSJ | FL | 90 |
| 301 | PMBHFLMA | FL | 91 |
| 265 | MIAMFLWD | FL | 92 |
| 287 | ORLDFLMA | FL | 93 |
| 1366 | NSVLTNWM | TN | 94 |
| 164 | COCOFLMA | FL | 95 |
| 187 | FTLDFLCR | FL | 96 |
| 188 | FTLDFLCY | FL | 97 |
| 330 | VRBHFLMA | FL | 98 |
| 1280 | GDVLTNMA | TN | 99 |
| 696 | NWORLASC | LA | 100 |
| 264 | MIAMFLSO | FL | 101 |
| 989 | CHRLNCCR | NC | 102 |
| 683 | NWORLAAR | LA | 103 |
| 1311 | KNVLTNYH | TN | 104 |
| 557 | BTRGLAMA | LA | 105 |
| 190 | FTLDFLMR | FL | 106 |
| 191 | FTLDFOA | FL | 107 |
| 1250 | CLVLTNMA | TN | 108 |
| 987 | CHRLNCCA | NC | 109 |
| 430 | LSVLKYBE | KY | 110 |

BellSouth Central Offices (All states excluding GA)

| Ref. # | CLLI | State | Combined CLEC Rank |
|---------------|-------------|--------------|---------------------------|
| 338 | WPBHFLRP | FL | 111 |
| 271 | MNDRFLLO | FL | 112 |
| 229 | JCVLFLRV | FL | 113 |
| 1020 | GNBONCEU | NC | 114 |
| 306 | PNSCFLBL | FL | 115 |
| 192 | FTLDFLPL | FL | 116 |
| 194 | FTLDFLSU | FL | 117 |
| 1236 | CHTGTNBR | TN | 118 |
| 986 | CHRLNCBO | NC | 119 |
| 687 | NWORLACM | LA | 120 |
| 1004 | CPHLNCRO | NC | 121 |
| 209 | HLWDFLWH | FL | 122 |
| 1341 | MMPHTNST | TN | 123 |
| 996 | CHRLNCSH | NC | 124 |
| 848 | JCSNMSCP | MS | 125 |
| 195 | FTLDFLWN | FL | 126 |
| 206 | HLWDFLHA | FL | 127 |
| 969 | AHVLNCOH | NC | 128 |
| 995 | CHRLNCRE | NC | 129 |
| 227 | JCVLFLNO | FL | 130 |
| 442 | LSVLKYWE | KY | 131 |
| 1069 | RLGHNCHO | NC | 132 |
| 436 | LSVLKYOA | KY | 133 |
| 992 | CHRLNCLP | NC | 134 |
| 356 | BWLGKYMA | KY | 135 |
| 207 | HLWDFLMA | FL | 136 |
| 218 | JCBHFLMA | FL | 137 |
| 305 | PNCYFLMA | FL | 138 |
| 1022 | GNBONCLA | NC | 139 |
| 220 | JCVLFLAR | FL | 140 |
| 335 | WPBHFLHH | FL | 141 |
| 319 | SNFRFLMA | FL | 142 |
| 439 | LSVLKYSM | KY | 143 |
| 222 | JCVLFLCL | FL | 144 |
| 90 | TSCLALMT | AL | 145 |
| 221 | JCVLFLBW | FL | 146 |
| 223 | JCVLFLFC | FL | 147 |

BellSouth Central Offices (All states excluding GA)

| Ref. # | CLLI | State | Combined CLEC Rank |
|---------------|-------------|--------------|---------------------------|
| 1247 | CLEVTNMA | TN | 148 |
| 201 | GSVLFLMA | FL | 149 |
| 691 | NWORLAMC | LA | 150 |
| 300 | PMBHFLFE | FL | 151 |
| 293 | OVIDFLCA | FL | 152 |
| 594 | FKTNLAMA | LA | 153 |
| 231 | JCVLFLSM | FL | 154 |
| 66 | MTGMALMT | AL | 155 |
| 243 | MIAMFLAE | FL | 156 |
| 245 | MIAMFLAP | FL | 157 |
| 99 | DCTRALMT | AL | 158 |
| 217 | JCBHFLAB | FL | 159 |
| 286 | ORLDFLCL | FL | 160 |
| 1102 | WNSLNCVI | NC | 161 |
| 428 | LSVLKYAN | KY | 162 |
| 981 | BURLNCDA | NC | 163 |
| 59 | MOBLALSH | AL | 164 |
| 314 | PTSLFLMA | FL | 165 |
| 246 | MIAMFLBA | FL | 166 |
| 248 | MIAMFLBR | FL | 167 |
| 123 | HNVIALMT | AL | 168 |
| 19 | BRHMALFS | AL | 169 |
| 690 | NWORLAMA | LA | 170 |
| 1287 | HDVLTNMA | TN | 171 |
| 290 | ORLDFLSA | FL | 172 |
| 1028 | GSTANCSO | NC | 173 |
| 52 | MOBLALAZ | AL | 174 |
| 1211 | SUVLSCMA | SC | 175 |
| 251 | MIAMFLFL | FL | 176 |
| 252 | MIAMFLGR | FL | 177 |
| 1131 | CHTNSCWA | SC | 178 |
| 54 | MOBLALOS | AL | 179 |
| 75 | PNSNALMA | AL | 180 |
| 1058 | MTOLNCCE | NC | 181 |
| 1070 | RLGHNCJO | NC | 182 |
| 1099 | WNSLNCFI | NC | 183 |
| 124 | HNVIALPW | AL | 184 |

BellSouth Central Offices (All states excluding GA)

| Ref. # | CLLI | State | Combined CLEC Rank |
|---------------|-------------|--------------|-------------------------------|
| 472 | OWBOKYMA | KY | 185 |
| 254 | MIAMFLIC | FL | 186 |
| 1125 | CHTNSCDP | SC | 187 |
| 255 | MIAMFLKE | FL | 188 |
| 1140 | CLMASCSSH | SC | 189 |
| 441 | LSVLKYVS | KY | 190 |
| 311 | PNVDFLMA | FL | 191 |
| 277 | NDADFLBR | FL | 192 |
| 1312 | LBNNTNMA | TN | 193 |
| 1166 | GNVLSCDT | SC | 194 |
| 281 | NSBHFLMA | FL | 195 |
| 256 | MIAMFLME | FL | 196 |
| 257 | MIAMFLNM | FL | 197 |
| 558 | BTRGLAOH | LA | 198 |
| 1126 | CHTNSCDT | SC | 199 |
| 33 | BSMRALHT | AL | 200 |
| 337 | WPBHFLRB | FL | 201 |
| 291 | ORPKFLMA | FL | 202 |
| 997 | CHRLNCTH | NC | 203 |
| 1169 | GNVLSCLR | SC | 204 |
| 327 | TTVLFLMA | FL | 205 |
| 260 | MIAMFLPB | FL | 206 |
| 261 | MIAMFLPL | FL | 207 |
| 849 | JCSNMSMB | MS | 208 |
| 1188 | MNPLSCES | SC | 209 |
| 577 | CVTNLAMA | LA | 210 |
| 279 | NDADFLLOL | FL | 211 |
| 998 | CHRLNCUN | NC | 212 |
| 1071 | RLGHNCMO | NC | 213 |
| 1130 | CHTNSCNO | SC | 214 |
| 310 | PNSCFLWA | FL | 215 |
| 276 | NDADFLAC | FL | 216 |
| 266 | MIAMFLWM | FL | 217 |
| 177 | DYBHFLOB | FL | 218 |
| 1138 | CLMASCSSA | SC | 219 |
| 686 | NWORLACA | LA | 220 |
| 1067 | RLGHNCGA | NC | 221 |

BellSouth Central Offices (All states excluding GA)

| Ref. # | CLLI | State | Combined CLEC Rank |
|---------------|-------------|--------------|-------------------------------|
| 336 | WPBHFLLE | FL | 222 |
| 624 | KNNRLAHN | LA | 223 |
| 1207 | SPBGSCMA | SC | 224 |
| 1080 | SLBRNCMA | NC | 225 |
| 278 | NDADFLGG | FL | 226 |
| 302 | PMBHFLTA | FL | 227 |
| 1143 | CLMASCSW | SC | 228 |
| 440 | LSVLKYTS | KY | 229 |
| 1257 | CRHTNMA | TN | 230 |
| 28 | BRHMALWL | AL | 231 |
| 435 | LSVLKYJT | KY | 232 |
| 639 | LFYTLAVM | LA | 233 |
| 332 | WPBHFLAN | FL | 234 |
| 1369 | OKRGTNMT | TN | 235 |
| 126 | HNVIALUN | AL | 236 |
| 438 | LSVLKYSL | KY | 237 |
| 483 | PMBRKYMA | KY | 238 |
| 292 | ORPKFLRW | FL | 239 |
| 559 | BTRGLASB | LA | 240 |
| 729 | SHPTLAMA | LA | 241 |
| 433 | LSVLKYFC | KY | 242 |
| 432 | LSVLKYCW | KY | 243 |
| 1300 | JCSNTNMA | TN | 244 |
| 561 | BTRGLAWN | LA | 245 |
| 1101 | WNSLNCLE | NC | 246 |
| 1277 | GALLTNMA | TN | 247 |
| 556 | BTRGLAIS | LA | 248 |
| 726 | SHPTLABS | LA | 249 |
| 689 | NWORLALK | LA | 250 |
| 1254 | CNVLTNMA | TN | 251 |
| 642 | LKCHLADT | LA | 252 |
| 727 | SHPTLACL | LA | 253 |
| 1388 | SMYRTNMA | TN | 254 |
| 1262 | DKSNTNMT | TN | 255 |
| 728 | SHPTLAHD | LA | 256 |
| 1031 | HNVLNCCH | NC | 257 |
| 971 | APEXNCCE | NC | 258 |

BellSouth Central Offices (All states excluding GA)

| Ref. # | CLLI | State | Combined CLEC Rank |
|---------------|-------------|--------------|---------------------------|
| 990 | CHRLNCDE | NC | 259 |
| 1346 | MRTWTNMA | TN | 260 |
| 852 | JCSNMSRW | MS | 261 |
| 1394 | SPFDTNMA | TN | 262 |
| 665 | MNVLLAMA | LA | 263 |
| 1023 | GNBONCMC | NC | 264 |
| 1106 | AIKNSCMA | SC | 265 |
| 991 | CHRLNCER | NC | 266 |
| 1072 | RLGHNCSE | NC | 267 |
| 645 | LKCHLAUN | LA | 268 |
| 1045 | LNTNNCMA | NC | 269 |
| 263 | MIAMFLSH | FL | 270 |
| 1017 | GLBONCMA | NC | 271 |
| 1308 | KNVLTNFC | TN | 272 |
| 1135 | CLMASCCH | SC | 273 |
| 1100 | WNSLNCGL | NC | 274 |
| 824 | GLPTMSTS | MS | 275 |
| 258 | MIAMFLNS | FL | 276 |
| 67 | MTGMALNO | AL | 277 |
| 259 | MIAMFLOL | FL | 278 |
| 1398 | SVVLTNMT | TN | 279 |
| 993 | CHRLNCMI | NC | 280 |
| 1085 | SSVLNCMA | NC | 281 |
| 982 | BURLNCEL | NC | 282 |
| 731 | SHPTLASG | LA | 283 |
| 1024 | GNBONCPG | NC | 284 |
| 74 | PHCYALMA | AL | 285 |
| 244 | MIAMFLAL | FL | 286 |
| 296 | PCBHFLNT | FL | 287 |
| 1037 | KNDLNCCE | NC | 288 |
| 165 | COCOFLME | FL | 289 |
| 434 | LSVLKYHA | KY | 290 |
| 838 | HTBGMSMA | MS | 291 |
| 1078 | SELMNCMA | NC | 292 |
| 60 | MOBLALSK | AL | 293 |
| 1009 | DVSNNCPO | NC | 294 |
| 582 | DNSPLAMA | LA | 295 |

BellSouth Central Offices (All states excluding GA)

| Ref. # | CLLI | State | Combined CLEC Rank |
|---------------|-------------|--------------|-------------------------------|
| 1098 | WNSLNCCL | NC | 296 |
| 10 | AUBNALMA | AL | 297 |
| 1083 | SRFDNCCE | NC | 298 |
| 399 | FRFTKYMA | KY | 299 |
| 247 | MIAMFLBC | FL | 300 |
| 1248 | CLMATNMA | TN | 301 |
| 1018 | GNBONCAP | NC | 302 |
| 1136 | CLMASCDF | SC | 303 |
| 1105 | ZBLNNCCE | NC | 304 |
| 321 | STAGFLMA | FL | 305 |
| 1096 | WNDLNCPI | NC | 306 |
| 846 | JCSNMSBL | MS | 307 |
| 11 | BLFNALMA | AL | 308 |
| 427 | LSVLKY26 | KY | 309 |
| 193 | FTLDFLSG | FL | 310 |
| 1242 | CHTGTNRO | TN | 311 |
| 212 | HMSTFLNA | FL | 312 |
| 159 | CCBHFLMA | FL | 313 |
| 985 | CARYNCWS | NC | 314 |
| 560 | BTRGLASW | LA | 315 |
| 295 | PAHKFLMA | FL | 316 |
| 1133 | CLMASCAR | SC | 317 |
| 250 | MIAMFLDB | FL | 318 |
| 122 | HNVIALW | AL | 319 |
| 1066 | RLGHNCDU | NC | 320 |
| 1142 | CLMASCSU | SC | 321 |
| 210 | HMSTFLEA | FL | 322 |
| 154 | BLGLFLMA | FL | 323 |
| 1258 | CRVLTNMA | TN | 324 |
| 851 | JCSNMSPC | MS | 325 |
| 1241 | CHTGTNRB | TN | 326 |
| 1053 | MGTNNCGR | NC | 327 |
| 89 | TSCLALDH | AL | 328 |
| ADD | HNVIALRA | AL | 329 |
| 730 | SHPTLAQB | LA | 330 |
| 978 | BOONNCKI | NC | 331 |
| 839 | HTBGMSWE | MS | 332 |

BellSouth Central Offices (All states excluding GA)

| Ref. # | CLLI | State | Combined CLEC Rank |
|---------------|-------------|--------------|---------------------------|
| 8 | ATHNALMA | AL | 333 |
| 610 | HMNDLAMA | LA | 334 |
| 874 | MDSNMSES | MS | 335 |
| 71 | OPLKALMT | AL | 336 |
| 769 | BILXMSED | MS | 337 |
| 269 | MLTNFLRA | FL | 338 |
| 1301 | JCSNTNNS | TN | 339 |
| 55 | MOBLALPR | AL | 340 |
| 552 | BTRGLABK | LA | 341 |
| 847 | JCSNMSCB | MS | 342 |
| 437 | LSVLKYSH | KY | 343 |
| 1129 | CHTNSCLB | SC | 344 |
| 492 | RCMDKYMA | KY | 345 |
| 411 | HNSNKYMA | KY | 346 |
| 1040 | LENRNCHA | NC | 347 |
| 1190 | NAGSSCMA | SC | 348 |
| 77 | PRVLALMA | AL | 349 |
| 213 | HTISFLMA | FL | 350 |
| 972 | ARDNNCCE | NC | 351 |
| 200 | GLBRFLMC | FL | 352 |
| 823 | GLPTMSLY | MS | 353 |
| 315 | PTSLFLSO | FL | 354 |
| 51 | MOBLALAP | AL | 355 |
| 1127 | CHTNSCJM | SC | 356 |
| 893 | OCSPMSGO | MS | 357 |
| 91 | TSCLALNO | AL | 358 |
| 317 | SBSTFLMA | FL | 359 |
| 527 | WNCHKYMA | KY | 360 |
| 58 | MOBLALSF | AL | 361 |
| 1239 | CHTGTNMV | TN | 362 |
| 1016 | GLBONCAD | NC | 363 |
| 770 | BILXMSMA | MS | 364 |
| 1400 | TLLHTNMA | TN | 365 |
| 109 | FRHPALMA | AL | 366 |
| 1368 | NWPTTNMT | TN | 367 |
| 56 | MOBLALSA | AL | 368 |
| 666 | MONRLADS | LA | 369 |

BellSouth Central Offices (All states excluding GA)

| Ref. # | CLLI | State | Combined CLEC Rank |
|---------------|-------------|--------------|---------------------------|
| 668 | MONRLAWM | LA | 370 |
| 57 | MOBLALSE | AL | 371 |
| 404 | GRTWKYMA | KY | 372 |
| 970 | AHVLNCOT | NC | 373 |
| 1385 | SHVLTNMA | TN | 374 |
| 780 | BRNDMSES | MS | 375 |
| 1414 | WNCHTNMA | TN | 376 |
| 1347 | MSCTTNMT | TN | 377 |
| 1315 | LNCYTNMA | TN | 378 |
| 240 | LYHNFLOH | FL | 379 |
| 1374 | PLSKTNMA | TN | 380 |
| 1317 | LRBGTNMA | TN | 381 |
| 555 | BTRGLAHR | LA | 382 |
| 294 | PACEFLPV | FL | 383 |
| 850 | JCSNMSNR | MS | 384 |
| 1243 | CHTGTNSE | TN | 385 |
| 204 | HBSDFLMA | FL | 386 |
| 1319 | LXTNTNMA | TN | 387 |
| 1343 | MNCHTNMA | TN | 388 |
| 1249 | CLTNTNMA | TN | 389 |
| 322 | STAGFLSH | FL | 390 |
| 1041 | LENRNCHU | NC | 391 |
| 308 | PNSCFLHC | FL | 392 |
| 1285 | GTBGTNMT | TN | 393 |
| 968 | AHVLNCBI | NC | 394 |
| 1238 | CHTGTNHT | TN | 395 |
| 304 | PNCYFLCA | FL | 396 |

BELLSOUTH/ADELPHIA RATES
NETWORK ELEMENTS
AND OTHER SERVICES

| DESCRIPTION | USOC | KY |
|--|-------|----------|
| NIDs | | |
| NID to NID Cross Connect, 2-Wire or 4-Wire, NRC | UNDC2 | NA |
| NID to NID Cross Connect, 2-Wire or 4-Wire, NRC | UNDC4 | NA |
| NID, 1-2 lines | UND12 | NA |
| NRC - 1st | UND12 | TBD |
| NRC - Add'l | UND12 | TBD |
| NRC - Disconnect Charge - 1st | UND12 | TBD |
| NRC - Disconnect Charge - Add'l | UND12 | TBD |
| NRC - Incremental Charge - Manual Service Order - 1st | SOMAN | TBD |
| NRC - Incremental Charge - Manual Service Order - Add'l | SOMAN | TBD |
| NRC - Incremental Charge - Manual Service Order - Disconnect | SOMAN | TBD |
| NID, 1-6 lines | UND16 | TBD |
| NRC - 1st | UND16 | TBN |
| NRC - Add'l | UND16 | TBN |
| NRC - Disconnect Charge - 1st | UND16 | TBN |
| NRC - Disconnect Charge - Add'l | UND16 | TBN |
| NRC - Incremental Charge - Manual Service Order - 1st | SOMAN | TBN |
| NRC - Incremental Charge - Manual Service Order - Add'l | SOMAN | TBN |
| NRC - Incremental Charge - Manual Service Order - Disconnect | SOMAN | TBN |
| Nonrecurring Charge - customer transfer, feature additions, changes (1) | | NA |
| LOOP, EXCLUDING NID | | |
| 2-Wire Analog VG Loop (Standard), per month | TBD | \$18.20 |
| NRC - 1st | | \$86.08 |
| NRC - Add'l | | \$58.57 |
| 2-Wire Analog VG Loop (Customized), per month | TBD | \$21.41 |
| NRC - 1st | | \$236.75 |
| NRC - Add'l | | \$177.10 |
| 4-Wire Analog VG Loop (Standard), per month | TBD | \$26.38 |
| NRC - 1st | | \$457.14 |
| NRC - Add'l | | \$348.83 |
| 2-Wire ISDN Digital Grade Loop (Standard), per month | TBD | \$29.65 |
| NRC - 1st | | \$541.28 |
| NRC - Add'l | | \$431.61 |
| 2-Wire ADSL Loop (Standard), per month | TBD | \$10.63 |
| NRC - 1st | | \$713.50 |
| NRC - Add'l | | \$609.44 |
| 2-Wire HDSL Loop (Standard), per month | TBD | \$7.40 |
| NRC - 1st | | \$713.50 |
| NRC - Add'l | | \$609.44 |
| 4-Wire HDSL Loop (Standard), per month | TBD | \$9.70 |
| NRC - 1st | | \$748.93 |
| NRC - Add'l | | \$646.17 |
| LOOP, INCLUDING NID | | |
| 2-Wire Analog VG Loop-SL1, per month | | |
| RC - Statewide, per month | UEAL2 | NA |
| RC - Zone 1, per month (Note 2) | UEAL2 | \$14.79 |
| RC - Zone 2, per month (Note 2) | UEAL2 | \$27.68 |
| RC - Zone 3, per month (Note 2) | UEAL2 | \$47.78 |
| RC - Zone 4, per month (Note 2) | UEAL2 | NA |
| NRC - 1st | UEAL2 | NA |
| NRC - Add'l | UEAL2 | NA |
| NRC - Disconnect Charge - 1st | UEAL2 | NA |

BELLSOUTH/ADELPHIA RATES
NETWORK ELEMENTS
AND OTHER SERVICES

| DESCRIPTION | USOC | KY |
|--|-------|---------|
| NRC - Disconnect Charge - Add'l | UEAL2 | NA |
| NRC - Incremental Charge - Manual Service Order - 1st | SOMAN | NA |
| NRC - Incremental Charge - Manual Service Order - Add'l | SOMAN | NA |
| NRC - Incremental Charge - Manual Service Order - Disconnect | SOMAN | NA |
| 2-Wire Analog VG Loop-SL2 w/loop or ground start signaling, per month | | |
| RC - Statewide, per month | UEAL2 | NA |
| RC - Zone 1, per month (Note 2) | UEAL2 | \$17.27 |
| RC - Zone 2, per month (Note 2) | UEAL2 | \$32.32 |
| RC - Zone 3, per month (Note 2) | UEAL2 | \$55.78 |
| RC - Zone 4, per month (Note 2) | UEAL2 | NA |
| NRC - 1st | UEAL2 | NA |
| NRC - Add'l | UEAL2 | NA |
| NRC - Disconnect Charge - 1st | UEAL2 | NA |
| NRC - Disconnect Charge - Add'l | UEAL2 | NA |
| NRC - Incremental Charge - Manual Service Order - 1st | SOMAN | NA |
| NRC - Incremental Charge - Manual Service Order - Add'l | SOMAN | NA |
| NRC - Incremental Charge - Manual Service Order - Disconnect | SOMAN | NA |
| NRC - Incremental Charge - Order Coordination - Time Specific (per LSR) | OCOSL | NA |
| 2-Wire Analog VG Loop-SL2 w/ reverse battery signaling, per month | | |
| RC - Statewide, per month | UEAR2 | NA |
| RC - Zone 1, per month (Note 2) | UEAR2 | \$17.27 |
| RC - Zone 2, per month (Note 2) | UEAR2 | \$32.32 |
| RC - Zone 3, per month (Note 2) | UEAR2 | \$55.78 |
| RC - Zone 4, per month (Note 2) | UEAR2 | NA |
| NRC - 1st | UEAR2 | NA |
| NRC - Add'l | UEAR2 | NA |
| NRC - Disconnect Charge - 1st | UEAR2 | NA |
| NRC - Disconnect Charge - Add'l | UEAR2 | NA |
| NRC - Incremental Charge - Manual Service Order - 1st | SOMAN | NA |
| NRC - Incremental Charge - Manual Service Order - Add'l | SOMAN | NA |
| NRC - Incremental Charge - Manual Service Order - Disconnect | SOMAN | NA |
| NRC - Incremental Charge - Order Coordination - Time Specific (per LSR) | OCOCL | NA |
| 4-Wire Analog VG Loop, per month | | |
| RC - Statewide, per month | UEAL4 | NA |
| RC - Zone 1, per month (Note 2) | UEAL4 | NA |
| RC - Zone 2, per month (Note 2) | UEAL4 | NA |
| RC - Zone 3, per month (Note 2) | UEAL4 | NA |
| RC - Zone 4, per month (Note 2) | UEAL4 | NA |
| NRC - 1st | UEAL4 | NA |
| NRC - Add'l | UEAL4 | NA |
| NRC - Disconnect Charge - 1st | UEAL4 | NA |
| NRC - Disconnect Charge - Add'l | UEAL4 | NA |
| NRC - Incremental Charge - Manual Service Order - 1st | SOMAN | NA |
| NRC - Incremental Charge - Manual Service Order - Add'l | SOMAN | NA |
| NRC - Incremental Charge - Manual Service Order - Disconnect | SOMAN | NA |
| NRC - Incremental Charge - Order Coordination - Time Specific (per LSR) | OCOSL | NA |
| 2-Wire ISDN Digital Grade Loop, per month | | |
| RC - Statewide, per month | U1L2X | NA |
| RC - Zone 1, per month (Note 2) | U1L2X | \$23.66 |
| RC - Zone 2, per month (Note 2) | U1L2X | \$44.28 |
| RC - Zone 3, per month (Note 2) | U1L2X | \$76.42 |
| RC - Zone 4, per month (Note 2) | U1L2X | NA |
| NRC - 1st | U1L2X | NA |

BELLSOUTH/ADELPHIA RATES
NETWORK ELEMENTS
AND OTHER SERVICES

| DESCRIPTION | USOC | KY |
|--|-------|----------|
| NRC - Add'l | U1L2X | NA |
| NRC - Disconnect Charge - 1st | U1L2X | NA |
| NRC - Disconnect Charge - Add'l | U1L2X | NA |
| NRC - Incremental Charge - Manual Service Order - 1st | SOMAN | NA |
| NRC - Incremental Charge - Manual Service Order - Add'l | SOMAN | NA |
| NRC - Incremental Charge - Manual Service Order - Disconnect | SOMAN | NA |
| NRC - Incremental Charge - Order Coordination - Time Specific (per LSR) | OCOSL | \$55.00 |
| 2-Wire Universal Digital Carrier (UDC), statewide, per month | UDC2X | NA |
| Zone 1, per month | UDC2X | \$23.66 |
| Zone 2, per month | UDC2X | \$44.28 |
| Zone 3, per month | UDC2X | \$76.42 |
| Zone 4, per month | UDC2X | NA |
| NRC - 1st | UDC2X | NA |
| NRC - Add'l | UDC2X | NA |
| NRC - Disconnect Charge - 1st | UDC2X | NA |
| NRC - Disconnect Charge - Add'l | UDC2X | NA |
| NRC - Incremental Charge - Manual Service Order - 1st | SOMAN | NA |
| NRC - Incremental Charge - Manual Service Order - Add'l | SOMAN | NA |
| NRC - Incremental Charge - Manual Service Order - Disconnect | SOMAN | NA |
| NRC - Incremental Charge - Order Coordination - Time Specific (per LSR) | OCOSL | \$55.00 |
| 2-Wire Asymmetrical Dig Subscriber Line (ADSL) Compatible Loop, <u>includes</u> manual service inquiry and facility reservation, statewide, per month | | |
| RC - Statewide, per month | UAL2X | NA |
| RC - Zone 1, per month (Note 2) | UAL2X | \$8.79 |
| RC - Zone 2, per month (Note 2) | UAL2X | \$16.46 |
| RC - Zone 3, per month (Note 2) | UAL2X | \$28.40 |
| RC - Zone 4, per month (Note 2) | UAL2X | NA |
| NRC - 1st | UAL2X | NA |
| NRC - Add'l | UAL2X | NA |
| NRC - Disconnect Charge - 1st | UAL2X | NA |
| NRC - Disconnect Charge - Add'l | SOMAN | NA |
| NRC - Incremental Charge - Manual Service Order - 1st | SOMAN | NA |
| NRC - Incremental Charge - Manual Service Order - Add'l | SOMAN | NA |
| NRC - Incremental Charge - Manual Service Order - Disconnect | SOMAN | NA |
| NRC - Incremental Charge - Order Coordination - Time Specific (per LSR) | OCOSL | NA |
| 2-Wire Asymmetrical Dig Subscriber Line (ADSL) Compatible Loop, <u>without</u> manual service inquiry and facility reservation, statewide, per month | UAL2W | NA |
| Zone 1, per month | UAL2W | \$8.79 |
| Zone 2, per month | UAL2W | \$16.46 |
| Zone 3, per month | UAL2W | \$28.40 |
| Zone 4, per month | UAL2W | NA |
| NRC - 1st | UAL2W | \$574.50 |
| NRC - Add'l | UAL2W | \$470.44 |
| NRC - Disconnect Charge - 1st | UAL2W | NA |
| NRC - Disconnect Charge - Add'l | UAL2W | NA |
| NRC - Incremental Charge - Manual Service Order - 1st | SOMAN | NA |
| NRC - Incremental Charge - Manual Service Order - Add'l | SOMAN | NA |
| NRC - Incremental Charge - Manual Service Order - Disconnect | SOMAN | NA |
| NRC - Incremental Charge - Order Coordination - Time Specific (per LSR) | OCOSL | \$55.00 |

BELLSOUTH/ADELPHIA RATES
NETWORK ELEMENTS
AND OTHER SERVICES

| DESCRIPTION | USOC | KY |
|--|-------|----------|
| 2-Wire High Bit Rate Dig Subscriber Line (HDSL) Compatible Loop, includes manual service inquiry and facility reservation, statewide, per month | | |
| RC - Statewide, per month | UHL2X | NA |
| RC - Zone 1, per month (Note 2) | UHL2X | \$6.29 |
| RC - Zone 2, per month (Note 2) | UHL2X | \$11.78 |
| RC - Zone 3, per month (Note 2) | UHL2X | \$20.33 |
| RC - Zone 4, per month (Note 2) | UHL2X | NA |
| NRC - 1st | UHL2X | NA |
| NRC - Add'l | UHL2X | NA |
| NRC - Disconnect Charge - 1st | UHL2X | NA |
| NRC - Disconnect Charge - Add'l | UHL2X | NA |
| NRC - Incremental Charge - Manual Service Order - 1st | SOMAN | NA |
| NRC - Incremental Charge - Manual Service Order - Add'l | SOMAN | NA |
| NRC - Incremental Charge - Manual Service Order - Disconnect | SOMAN | NA |
| NRC - Incremental Charge - Order Coordination - Time Specific (per LSR) | OCOSL | \$55.00 |
| 2-Wire High Bit Rate Dig Subscriber Line (HDSL) Compatible Loop, without manual service inquiry and facility reservation, statewide, per month | | |
| Zone 1, per month | UHL2W | NA |
| Zone 2, per month | UHL2W | \$6.29 |
| Zone 3, per month | UHL2W | \$11.78 |
| Zone 4, per month | UHL2W | \$20.33 |
| NRC - 1st | UHL2W | NA |
| NRC - Add'l | UHL2W | \$574.50 |
| NRC - Disconnect Charge - 1st | UHL2W | \$470.44 |
| NRC - Disconnect Charge - Add'l | UHL2W | NA |
| NRC - Incremental Charge - Manual Service Order - 1st | SOMAN | NA |
| NRC - Incremental Charge - Manual Service Order - Add'l | SOMAN | NA |
| NRC - Incremental Charge - Manual Service Order - Disconnect | SOMAN | NA |
| NRC - Incremental Charge - Order Coordination - Time Specific (per LSR) | OCOSL | NA |
| 4-Wire High Bit Rate Dig Subscriber Line (HDSL) Compatible Loop, includes manual service inquiry and facility reservation, per month, statewide | | |
| RC - Statewide, per month | UHL4X | NA |
| RC - Zone 1, per month (Note 2) | UHL4X | \$7.68 |
| RC - Zone 2, per month (Note 2) | UHL4X | \$14.38 |
| RC - Zone 3, per month (Note 2) | UHL4X | \$24.82 |
| RC - Zone 4, per month (Note 2) | UHL4X | NA |
| NRC - 1st | UHL4X | NA |
| NRC - Add'l | UHL4X | NA |
| NRC - Disconnect Charge - 1st | UHL4X | NA |
| NRC - Disconnect Charge - Add'l | UHL4X | NA |
| NRC - Incremental Charge - Manual Service Order - 1st | SOMAN | NA |
| NRC - Incremental Charge - Manual Service Order - Add'l | SOMAN | NA |
| NRC - Incremental Charge - Manual Service Order - Disconnect | SOMAN | NA |
| NRC - Incremental Charge - Order Coordination - Time Specific (per LSR) | OCOSL | NA |
| 4-Wire High Bit Rate Dig Subscriber Line (HDSL) Compatible Loop, without manual service inquiry and facility reservation, per month, statewide | | |
| Zone 1, per month | UHL4W | NA |
| Zone 2, per month | UHL4W | \$7.68 |
| Zone 3, per month | UHL4W | \$14.38 |
| Zone 4, per month | UHL4W | \$24.82 |

BELLSOUTH/ADELPHIA RATES
NETWORK ELEMENTS
AND OTHER SERVICES

| DESCRIPTION | USOC | KY |
|---|-------|----------|
| Zone 4, per month | UHL4W | NA |
| NRC - 1st | UHL4W | \$609.93 |
| NRC - Add'l | UHL4W | \$507.17 |
| NRC - Disconnect Charge - 1st | UHL4W | NA |
| NRC - Disconnect Charge - Add'l | UHL4W | NA |
| NRC - Incremental Charge - Manual Service Order - 1st | SOMAN | NA |
| NRC - Incremental Charge - Manual Service Order - Add'l | SOMAN | NA |
| NRC - Incremental Charge - Manual Service Order - Disconnect | SOMAN | NA |
| NRC - Incremental Charge - Order Coordination - Time Specific (per LSR) | OCOSL | \$55.00 |
| 4-Wire DS1 Digital Loop, per month | | |
| RC - Statewide, per month | USLXX | NA |
| RC - Zone 1, per month (Note 2) | USLXX | \$50.26 |
| RC - Zone 2, per month (Note 2) | USLXX | \$94.06 |
| RC - Zone 3, per month (Note 2) | USLXX | \$162.34 |
| RC - Zone 4, per month (Note 2) | USLXX | NA |
| NRC - 1st | USLXX | \$849.80 |
| NRC - Add'l | USLXX | \$523.27 |
| NRC - Disconnect Charge - 1st | USLXX | NA |
| NRC - Disconnect Charge - Add'l | USLXX | NA |
| NRC - Incremental Charge - Manual Service Order - 1st | SOMAN | NA |
| NRC - Incremental Charge - Manual Service Order - Add'l | SOMAN | NA |
| NRC - Incremental Charge - Manual Service Order - Disconnect | SOMAN | NA |
| NRC - Incremental Charge - Order Coordination - Time Specific (per LSR) | OCOSL | \$55.00 |
| 4-Wire 56 Kbps Dig Grade Loop, per month | | |
| RC - Statewide, per month | UDL56 | NA |
| RC - Zone 1, per month (Note 2) | UDL56 | NA |
| RC - Zone 2, per month (Note 2) | UDL56 | NA |
| RC - Zone 3, per month (Note 2) | UDL56 | NA |
| RC - Zone 4, per month (Note 2) | UDL56 | NA |
| NRC - 1st | UDL56 | NA |
| NRC - Add'l | UDL56 | NA |
| NRC - Disconnect Charge - 1st | UDL56 | NA |
| NRC - Disconnect Charge - Add'l | UDL56 | NA |
| NRC - Incremental Charge - Manual Service Order - 1st | SOMAN | NA |
| NRC - Incremental Charge - Manual Service Order - Add'l | SOMAN | NA |
| NRC - Incremental Charge - Manual Service Order - Disconnect | SOMAN | NA |
| NRC - Incremental Charge - Order Coordination - Time Specific (per LSR) | OCOSL | NA |
| 4-Wire 64 Kbps Dig Grade Loop, per month | | |
| RC - Statewide, per month | UDL64 | NA |
| RC - Zone 1, per month (Note 2) | UDL64 | NA |
| RC - Zone 2, per month (Note 2) | UDL64 | NA |
| RC - Zone 3, per month (Note 2) | UDL64 | NA |
| RC - Zone 4, per month (Note 2) | UDL64 | NA |
| NRC - 1st | UDL64 | NA |
| NRC - Add'l | UDL64 | NA |
| NRC - Disconnect Charge - 1st | UDL64 | NA |
| NRC - Disconnect Charge - Add'l | UDL64 | NA |
| NRC - Incremental Charge - Manual Service Order - 1st | SOMAN | NA |
| NRC - Incremental Charge - Manual Service Order - Add'l | SOMAN | NA |
| NRC - Incremental Charge - Manual Service Order - Disconnect | SOMAN | NA |
| NRC - Incremental Charge - Order Coordination - Time Specific (per LSR) | OCOSL | NA |

BELLSOUTH/ADELPHIA RATES
NETWORK ELEMENTS
AND OTHER SERVICES

| DESCRIPTION | USOC | KY |
|---|-------|----------|
| 2-Wire Unbundled Copper Loop/Short (less than or equal to 18kft), includes manual service inquiry and facility reservation, per month, statewide * | | |
| RC - Statewide, per month | UCLPB | \$11.89 |
| RC - Zone 1, per month (Note 2) | UCLPB | TBD |
| RC - Zone 2, per month (Note 2) | UCLPB | TBD |
| RC - Zone 3, per month (Note 2) | UCLPB | TBD |
| RC - Zone 4, per month (Note 2) | UCLPB | NA |
| NRC - 1st | UCLPB | \$713.50 |
| NRC - Add'l | UCLPB | \$609.44 |
| NRC - Disconnect Charge - 1st | UCLPB | NA |
| NRC - Disconnect Charge - Add'l | UCLPB | NA |
| NRC - Incremental Charge - Manual Service Order - 1st | SOMAN | \$47.00 |
| NRC - Incremental Charge - Manual Service Order - Add'l | SOMAN | \$21.00 |
| NRC - Incremental Charge - Manual Service Order - Disconnect - 1st | SOMAN | \$17.77 |
| NRC - Incremental Charge - Manual Service Order - Disconnect - Add'l | SOMAN | \$17.77 |
| NRC - Incremental Charge - Manual Order Coordination - per loop | UCLMC | \$16.00 |
| 2-Wire Unbundled Copper Loop/Short (less than or equal to 18kft), without manual service inquiry and facility reservation, per month, statewide | | |
| Zone 1, per month | UCLPW | NA |
| Zone 2, per month | UCLPW | TBD |
| Zone 3, per month | UCLPW | TBD |
| Zone 4, per month | UCLPW | NA |
| NRC - 1st | UCLPW | \$574.50 |
| NRC - Add'l | UCLPW | \$470.44 |
| NRC - Disconnect Charge - 1st | UCLPW | NA |
| NRC - Disconnect Charge - Add'l | UCLPW | NA |
| NRC - Incremental Charge - Manual Service Order - 1st | SOMAN | \$47.00 |
| NRC - Incremental Charge - Manual Service Order - Add'l | SOMAN | \$21.00 |
| NRC - Incremental Charge - Manual Service Order - Disconnect - 1st | SOMAN | \$17.77 |
| NRC - Incremental Charge - Manual Service Order - Disconnect - Add'l | SOMAN | \$17.77 |
| NRC - Incremental Charge - Manual Order Coordination - per loop | UCLMC | NA |
| 2-Wire Unbundled Copper Loop/Long (greater than 18kft), includes manual service inquiry and facility reservation, per month, statewide | | |
| RC - Statewide, per month | UCL2L | \$40.00 |
| RC - Zone 1, per month (Note 2) | UCL2L | TBD |
| RC - Zone 2, per month (Note 2) | UCL2L | TBD |
| RC - Zone 3, per month (Note 2) | UCL2L | TBD |
| RC - Zone 4, per month (Note 2) | UCL2L | NA |
| NRC - 1st | UCL2L | \$713.50 |
| NRC - Add'l | UCL2L | \$609.44 |
| NRC - Disconnect Charge - 1st | UCL2L | NA |
| NRC - Disconnect Charge - Add'l | UCL2L | NA |
| NRC - Incremental Charge - Manual Service Order - 1st | SOMAN | \$47.00 |
| NRC - Incremental Charge - Manual Service Order - Add'l | SOMAN | \$21.00 |
| NRC - Incremental Charge - Manual Service Order - Disconnect - 1st | SOMAN | \$17.77 |
| NRC - Incremental Charge - Manual Service Order - Disconnect - Add'l | SOMAN | \$17.77 |
| NRC - Incremental Charge - Manual Order Coordination - per loop | UCLMC | \$16.00 |

BELLSOUTH/ADELPHIA RATES
NETWORK ELEMENTS
AND OTHER SERVICES

| DESCRIPTION | USOC | KY |
|--|-------|----------|
| 2-Wire Unbundled Copper Loop/Long (greater than 18kft), <u>without</u> manual service inquiry and facility reservation, per month, statewide | UCL2W | \$40.00 |
| Zone 1, per month | UCL2W | TBD |
| Zone 2, per month | UCL2W | TBD |
| Zone 3, per month | UCL2W | TBD |
| Zone 4, per month | UCL2W | NA |
| NRC - 1st | UCL2W | \$574.50 |
| NRC - Add'l | UCL2W | \$470.44 |
| NRC - Disconnect Charge - 1st | UCL2W | NA |
| NRC - Disconnect Charge - Add'l | UCL2W | NA |
| NRC - Incremental Charge - Manual Service Order - 1st | SOMAN | \$47.00 |
| NRC - Incremental Charge - Manual Service Order - Add'l | SOMAN | \$21.00 |
| NRC - Incremental Charge - Manual Service Order - Disconnect - 1st | SOMAN | \$17.77 |
| NRC - Incremental Charge - Manual Service Order - Disconnect - Add'L | SOMAN | \$17.77 |
| NRC - Incremental Charge - Manual Order Coordination - per loop | UCLMC | \$16.00 |
| 4-Wire Unbundled Copper Loop/Short (less than or equal to 18kft), <u>includes</u> manual service inquiry and facility reservation, per month, statewide * | UCL4S | TBD |
| Zone 1, per month | UCL4S | TBD |
| Zone 2, per month | UCL4S | TBD |
| Zone 3, per month | UCL4S | TBD |
| Zone 4, per month | UCL4S | NA |
| NRC - 1st | UCL4S | TBD |
| NRC - Add'l | UCL4S | TBD |
| NRC - Disconnect Charge - 1st | UCL4S | TBD |
| NRC - Disconnect Charge - Add'l | UCL4S | TBD |
| NRC - Incremental Charge - Manual Service Order - 1st | SOMAN | TBD |
| NRC - Incremental Charge - Manual Service Order - Add'l | SOMAN | TBD |
| NRC - Incremental Charge - Manual Service Order - Disconnect | SOMAN | TBD |
| NRC - Incremental Charge - Manual Order Coordination - per loop | UCLMC | TBD |
| 4-Wire Unbundled Copper Loop/Short (less than or equal to 18kft), <u>without</u> manual service inquiry and facility reservation, per month, statewide | UCL4W | TBD |
| Zone 1, per month | UCL4W | TBD |
| Zone 2, per month | UCL4W | TBD |
| Zone 3, per month | UCL4W | TBD |
| Zone 4, per month | UCL4W | NA |
| NRC - 1st | UCL4W | TBD |
| NRC - Add'l | UCL4W | TBD |
| NRC - Disconnect Charge - 1st | UCL4W | TBD |
| NRC - Disconnect Charge - Add'l | UCL4W | TBD |
| NRC - Incremental Charge - Manual Service Order - 1st | SOMAN | TBD |
| NRC - Incremental Charge - Manual Service Order - Add'l | SOMAN | TBD |
| NRC - Incremental Charge - Manual Service Order - Disconnect | SOMAN | TBD |
| NRC - Incremental Charge - Manual Order Coordination - per loop | UCLMC | TBD |
| 4-Wire Unbundled Copper Loop/Long (greater than 18kft), <u>includes</u> manual service inquiry and reservation, per month, statewide | UCL4L | TBD |
| Zone 1, per month | UCL4L | TBD |
| Zone 2, per month | UCL4L | TBD |
| Zone 3, per month | UCL4L | TBD |
| Zone 4, per month | UCL4L | NA |

BELLSOUTH/ADELPHIA RATES
NETWORK ELEMENTS
AND OTHER SERVICES

| DESCRIPTION | USOC | KY |
|--|-------|------------|
| NRC - 1st | UCL4L | TBD |
| NRC - Add'l | UCL4L | TBD |
| NRC - Disconnect Charge - 1st | UCL4L | TBD |
| NRC - Disconnect Charge - Add'l | UCL4L | TBD |
| NRC - Incremental Charge - Manual Service Order - 1st | SOMAN | TBD |
| NRC - Incremental Charge - Manual Service Order - Add'l | SOMAN | TBD |
| NRC - Incremental Charge - Manual Service Order - Disconnect | SOMAN | TBD |
| NRC - Incremental Charge - Manual Order Coordination - per loop | UCLMC | TBD |
| 4-Wire Unbundled Copper Loop/Long (greater than 18kft), without manual service inquiry and facility reservation, per month, statewide | UCL4O | TBD |
| Zone 1, per month | UCL4O | TBD |
| Zone 2, per month | UCL4O | TBD |
| Zone 3, per month | UCL4O | TBD |
| Zone 4, per month | UCL4O | NA |
| NRC - 1st | UCL4O | TBD |
| NRC - Add'l | UCL4O | TBD |
| NRC - Disconnect Charge - 1st | UCL4O | TBD |
| NRC - Disconnect Charge - Add'l | UCL4O | TBD |
| NRC - Incremental Charge - Manual Service Order - 1st | SOMAN | TBD |
| NRC - Incremental Charge - Manual Service Order - Add'l | SOMAN | TBD |
| NRC - Incremental Charge - Manual Service Order - Disconnect | SOMAN | TBD |
| NRC - Incremental Charge - Manual Order Coordination - per loop | UCLMC | TBD |
| DS3 Local Loop | | |
| DS3 Unbundled Local Loop - per mile | 1L5ND | \$43.69 |
| DS3 Unbundled Local Loop- per Facility Termination | UE3PX | \$436.95 |
| NRC - Facility Termination - 1st | UE3PX | \$1,091.00 |
| NRC - Facility Termination - Add'l | UE3PX | \$661.23 |
| NRC - Facility Termination - Disconnect - 1st | UE3PX | NA |
| NRC - Facility Termination - Disconnect - Add'l | UE3PX | NA |
| NRC - Manual Svc Order, per LSR | SOMAN | \$19.99 |
| NRC - Manual Svc Order, per LSR disconnect | SOMAN | NA |
| NRC - Electronic Svc Order, per LSR | SOMEK | \$3.50 |
| NRC - Electronic Svc Order, per LSR disconnect | SOMEK | NA |
| NRC - Incremental Charge-Manual Svc Order - 1st | SOMAN | NA |
| NRC - Incremental Charge-Manual Svc Order - Add'l | SOMAN | NA |
| NRC - Incremental Cost - Manual Svc. Order vs. Elect-Disconnect-1st | SOMAN | NA |
| NRC - Incremental Cost - Manual Svc. Order vs. Elect-Disconnect-Add'l | SOMAN | NA |
| STS-1 Local Loop | | |
| STS-1 Unbundled Local Loop - per mile | 1L5ND | \$43.69 |
| STS-1 Unbundled Local Loop- per Facility Termination | UDLS1 | \$436.95 |
| NRC - STS-1 - Facility Termination - 1st | UDLS1 | \$1,091 |
| NRC - STS-1 - Facility Termination - Add'l | UDLS1 | \$661.23 |
| NRC - STS-1 - Facility Termination - Disconnect - 1st | UDLS1 | NA |
| NRC - STS-1 - Facility Termination - Disconnect - Add'l | UDLS1 | NA |
| NRC - Manual Svc Order, per LSR | SOMAN | \$19.99 |
| NRC - Manual Svc Order, per LSR disconnect | SOMAN | NA |
| NRC - Electronic Svc Order, per LSR | SOMEK | \$3.50 |
| NRC - Electronic Svc Order, per LSR disconnect | SOMEK | NA |
| NRC - STS-1 - Incremental Charge-Manual Svc Order - 1st | SOMAN | NA |
| NRC - STS-1 - Incremental Charge-Manual Svc Order - Add'l | SOMAN | NA |
| NRC - STS-1 - Incremental Cost - Manual Svc. Order vs. Elect-Disconnect-1st | SOMAN | NA |
| NRC - STS-1 - Incremental Cost - Manual Svc. Order vs. Elect-Disconnect-Add'l | SOMAN | NA |
| OC3- Local Loop | | |

BELLSOUTH/ADELPHIA RATES
NETWORK ELEMENTS
AND OTHER SERVICES

| DESCRIPTION | USOC | KY |
|---|-------|----------|
| Local Loop - OC3 - per Mile | TBD | \$33.15 |
| Local Loop - OC3 - per Facility Termination | TBD | \$713.29 |
| NRC - OC3 - Facility Termination - 1st | TBD | \$1,543 |
| NRC - OC3 - Facility Termination - Add'l | TBD | \$661.23 |
| NRC - OC3 - Facility Termination - Disconnect - 1st | TBD | NA |
| NRC - OC3 - Facility Termination - Disconnect - Add'l | TBD | NA |
| NRC - Manual Svc Order, per LSR | SOMAN | \$19.99 |
| NRC - Manual Svc Order, per LSR disconnect | SOMAN | NA |
| NRC - Electronic Svc Order, per LSR | SOMEK | \$3.50 |
| NRC - Electronic Svc Order, per LSR disconnect | SOMEK | NA |
| NRC - OC3 - Incremental Charge--Manual Svc Order - 1st | SOMAN | \$93.12 |
| NRC - OC3 - Incremental Charge--Manual Svc Order - Add'l | SOMAN | \$93.12 |
| NRC - OC3 -Incremental Cost - Manual Svc. Order vs. Elect-Disconnect-1st | SOMAN | NA |
| NRC - OC3 -Incremental Cost - Manual Svc. Order vs. Elect-Disconnect-Add'l | SOMAN | NA |
| OC -12 Local Loop | | |
| Local Loop - OC12 - per Mile | TBD | \$40.80 |
| Local Loop - OC12 - per Facility Termination | TBD | \$2,457 |
| NRC - OC12 - Facility Termination - 1st | TBD | \$1,858 |
| NRC - OC12 - Facility Termination - Add'l | TBD | \$661.23 |
| NRC - OC12 - Facility Termination - Disconnect - 1st | TBD | NA |
| NRC - OC12 - Facility Termination - Disconnect - Add'l | TBD | NA |
| NRC - Manual Svc Order, per LSR | SOMAN | \$19.99 |
| NRC - Manual Svc Order, per LSR disconnect | SOMAN | NA |
| NRC - Electronic Svc Order, per LSR | SOMEK | \$3.50 |
| NRC - Electronic Svc Order, per LSR disconnect | SOMEK | NA |
| NRC -OC12 - Incremental Charge - Manual Svc Order - 1st | SOMAN | \$93.12 |
| NRC - OC12 - Incremental Charge - Manual Svc Order - Add'l | SOMAN | \$93.12 |
| NRC - OC12 - Incremental Cost-Manual Svc. Order vs. Elect-Disconnect-1st | SOMAN | NA |
| NRC - OC12 - Incremental Cost-Manual Svc. Order vs. Elect-Disconnect-Add'l | SOMAN | NA |
| OC - 48 Local Loop | | |
| Local Loop - OC48 - per Mile | TBD | \$133.84 |
| Local Loop - OC48 - per Facility Termination | TBD | \$2,129 |
| Local Loop - OC12 interface on OC48 Facility | TBD | \$725.77 |
| NRC - OC48 - Facility Termination - 1st | TBD | \$1,858 |
| NRC - OC48 - Facility Termination - Add'l | TBD | \$661.23 |
| NRC - OC48 - Interface OC12 on OC48 - 1st | TBD | \$844.21 |
| NRC - OC48 - Interface OC12 on OC48 - Add'l | TBD | \$516.89 |
| NRC - OC48 - Facility Termination - Disconnect - 1st | TBD | NA |
| NRC - OC48 - Facility Termination - Disconnect - Add'l | TBD | NA |
| NRC - OC48- Interface OC12 on OC48 - Disconnect - 1st | TBD | NA |
| NRC - OC48 - Interface OC12 on OC48 - Disconnect - Add'l | TBD | NA |
| NRC - Manual Svc Order, per LSR | SOMAN | \$19.99 |
| NRC - Manual Svc Order, per LSR disconnect | SOMAN | NA |
| NRC - Electronic Svc Order, per LSR | SOMEK | \$3.50 |
| NRC - Electronic Svc Order, per LSR disconnect | SOMEK | NA |
| NRC - OC48 - Facility Termination-Manual Svc Order vs Electronic-Disconnect-1st | SOMAN | NA |
| NRC - OC48 - Facility Termination-Manual Svc Order vs Electronic-Disconnect-Add'l | SOMAN | NA |
| NRC - OC48 - Interface - Manual Svc Order vs Electronic-Disconnect-1st | SOMAN | NA |
| NRC - OC48 - Interface - Manual Svc Order vs Electronic-Disconnect-Add'l | SOMAN | NA |
| NRC - OC-48 - Incremental Charge--Manual Svc Order-1st | SOMAN | \$93.12 |
| NRC - OC-48 - Incremental Charge--Manual Svc Order-Add'l | SOMAN | \$93.12 |
| NRC - OC48 - Interface OC12 on OC48 - Incremental Charge--Manual Svc Order | SOMAN | \$93.12 |
| NRC - OC48 - Interface OC12 on OC48 - Incremental Charge--Manual Svc Order | SOMAN | \$93.12 |

BELLSOUTH/ADELPHIA RATES
NETWORK ELEMENTS
AND OTHER SERVICES

| DESCRIPTION | USOC | KY |
|---|-------|----------|
| Unbundled Loop Modification | | |
| NRC - Load Coil/Equipment Removal per 2 Wire pair - Loops less than or equal to 18kft | ULM2L | \$80.55 |
| NRC - Load Coil/Equipment Removal per 2 Wire pair - Loops greater than 18kft 1st | ULM2G | \$880.00 |
| NRC - Load Coil/Equipment Removal per 2 Wire pair - Loops greater than 18kft Add'l | ULM2G | \$27.30 |
| NRC - Load Coil/Equipment Removal per 4 Wire pair - Loops less than or equal to 18kft | ULM4G | TBN |
| NRC - Load Coil/Equipment Removal per 4 Wire pair - Loops greater than 18kft 1st | ULM4L | TBN |
| NRC - Load Coil/Equipment Removal per 4 Wire pair - Loops greater than 18kft Add'l | ULM4L | TBN |
| NRC - Bridge Tap Removal per pair unloaded | ULMBT | \$121.14 |
| UNBUNDLED SUB-LOOPS | | |
| SUB-LOOP DISTRIBUTION | | |
| Cross-Box Set-Up | | |
| NRC - Set-Up per Cross Box location in the field - CLEC Feeder Facility set-up | USBSA | TBN |
| NRC - Set-Up per Cross Box location in the field - per 25 pair panel set-up | USBSB | TBN |
| NRC - Set-Up per Building Equipment Room - CLEC Feeder Facility set-up | USBSC | TBN |
| NRC - Set-Up per Building Equipment Room - per 25 pair panel set-up | USBSD | TBN |
| Loop Distribution per 2-Wire Analog VG Sub-Loop, per month | | |
| NRC - 1st | USBN2 | \$10.83 |
| NRC - Add'l | USBN2 | \$459.85 |
| NRC - Disconnect Charge - 1st | USBN2 | \$352.89 |
| NRC - Disconnect Charge - Add'l | USBN2 | TBN |
| NRC - Incremental Charge - Manual Service Order - 1st | SOMAN | TBN |
| NRC - Incremental Charge - Manual Service Order - Add'l | SOMAN | TBN |
| NRC - Incremental Charge - Manual Service Order - Disconnect | SOMAN | TBN |
| NRC - Incremental Charge - Manual Order Coordination - per loop | USBMC | TBN |
| Loop Distribution per 4-Wire Analog VG Sub-Loop, per month | | |
| NRC - 1st | USBN4 | TBN |
| NRC - Add'l | USBN4 | TBN |
| NRC - Disconnect Charge - 1st | USBN4 | TBN |
| NRC - Disconnect Charge - Add'l | USBN4 | TBN |
| NRC - Incremental Charge - Manual Service Order - 1st | SOMAN | TBN |
| NRC - Incremental Charge - Manual Service Order - Add'l | SOMAN | TBN |
| NRC - Incremental Charge - Manual Service Order - Disconnect | SOMAN | TBN |
| NRC - Incremental Charge - Manual Order Coordination - per loop | USBMC | TBN |
| Loop Distribution per 2 Wire Unbundled Copper Sub-Loop, per month | | |
| NRC - 1st | UCS2X | TBN |
| NRC - Add'l | UCS2X | TBN |
| NRC - Disconnect Charge - 1st | UCS2X | TBN |
| NRC - Disconnect Charge - Add'l | UCS2X | TBN |
| NRC - Incremental Charge - Manual Service Order - 1st | SOMAN | TBN |
| NRC - Incremental Charge - Manual Service Order - Add'l | SOMAN | TBN |
| NRC - Incremental Charge - Manual Service Order - Disconnect | SOMAN | TBN |
| NRC - Incremental Charge - Manual Order Coordination - per loop | USBMC | TBN |
| Loop Distribution per 4 Wire Unbundled Copper Sub-Loop, per month | | |
| NRC - 1st | UCS4X | TBN |

BELLSOUTH/ADELPHIA RATES
NETWORK ELEMENTS
AND OTHER SERVICES

| DESCRIPTION | USOC | KY |
|---|-------|-----|
| NRC - 1st | UCS4X | TBN |
| NRC - Add'l | UCS4X | TBN |
| NRC - Disconnect Charge - 1st | UCS4X | TBN |
| NRC - Disconnect Charge - Add'l | UCS4X | TBN |
| NRC - Incremental Charge - Manual Service Order - 1st | SOMAN | TBN |
| NRC - Incremental Charge - Manual Service Order - Add'l | SOMAN | TBN |
| NRC - Incremental Charge - Manual Service Order - Disconnect | SOMAN | TBN |
| NRC - Incremental Charge - Manual Order Coordination - per loop | USBMC | TBN |
| Sub-Loop-Intrabuilding Network Cable (INC) (a.k.a., riser cable), 2W analog, per m | USBR2 | TBN |
| NRC - 1st | USBR2 | TBN |
| NRC - Add'l | USBR2 | TBN |
| NRC - Disconnect Charge - 1st | USBR2 | TBN |
| NRC - Disconnect Charge - Add'l | USBR2 | TBN |
| NRC - Incremental Charge - Manual Service Order - 1st | SOMAN | TBN |
| NRC - Incremental Charge - Manual Service Order - Add'l | SOMAN | TBN |
| NRC - Incremental Charge - Manual Service Order - Disconnect | SOMAN | TBN |
| NRC - Incremental Charge - Manual Order Coordination - per loop | USBMC | TBN |
| Sub-Loop-Intrabuilding Network Cable (a.k.a.,riser cable), 4W analog, per month | USBR4 | TBN |
| NRC - 1st | USBR4 | TBN |
| NRC - Add'l | USBR4 | TBN |
| NRC - Disconnect Charge - 1st | USBR4 | TBN |
| NRC - Disconnect Charge - Add'l | USBR4 | TBN |
| NRC - Incremental Charge - Manual Service Order - 1st | SOMAN | TBN |
| NRC - Incremental Charge - Manual Service Order - Add'l | SOMAN | TBN |
| NRC - Incremental Charge - Manual Service Order - Disconnect | SOMAN | TBN |
| NRC - Incremental Charge - Manual Order Coordination - per loop | USBMC | TBN |
| SUB-LOOP FEEDER | | |
| Cross-Box Set-Up | | |
| NRC - DS0 Set-Up per Cross Box location - CLEC Distribution Facility set-up | USBFW | TBN |
| NRC - DS0 Set-Up per Cross Box location - per 25 pair panel set-up | USBFX | TBN |
| NRC - DS1 Set-Up per Cross Box location - CLEC Distribution Facility set-up | USBFY | TBN |
| NRC - DS1 Set-Up per Cross Box location - per pair panel set-up | USBFZ | TBN |
| 2-Wire Analog VG Ground-Start Unbundled Sub-Loop Feeder, per month | USBFA | TBN |
| NRC - 1st | USBFA | TBN |
| NRC - Add'l | USBFA | TBN |
| NRC - Disconnect Charge - 1st | USBFA | TBN |
| NRC - Disconnect Charge - Add'l | USBFA | TBN |
| NRC - Incremental Charge - Manual Service Order - 1st | SOMAN | TBN |
| NRC - Incremental Charge - Manual Service Order - Add'l | SOMAN | TBN |
| NRC - Incremental Charge - Manual Service Order - Disconnect | SOMAN | TBN |
| NRC - Incremental Charge - Manual Order Coordination - per loop | TBD | TBN |
| 2-Wire Analog VG Loop-Start Unbundled Sub-Loop Feeder, per month | USBFB | TBN |
| NRC - 1st | USBFB | TBN |
| NRC - Add'l | USBFB | TBN |
| NRC - Disconnect Charge - 1st | USBFB | TBN |
| NRC - Disconnect Charge - Add'l | USBFB | TBN |
| NRC - Incremental Charge - Manual Service Order - 1st | SOMAN | TBN |
| NRC - Incremental Charge - Manual Service Order - Add'l | SOMAN | TBN |

BELLSOUTH/ADELPHIA RATES
NETWORK ELEMENTS
AND OTHER SERVICES

| DESCRIPTION | USOC | KY |
|--|-------|-----|
| NRC - Incremental Charge - Manual Service Order - Disconnect | SOMAN | TBN |
| NRC - Incremental Charge - Manual Order Coordination - per loop | TBD | TBN |
| 2-Wire Analog VG Reverse Battery Unbundled Sub-Loop Feeder, per month | USBFC | TBN |
| NRC - 1st | USBFC | TBN |
| NRC - Add'l | USBFC | TBN |
| NRC - Disconnect Charge - 1st | USBFC | TBN |
| NRC - Disconnect Charge - Add'l | USBFC | TBN |
| NRC - Incremental Charge - Manual Service Order - 1st | SOMAN | TBN |
| NRC - Incremental Charge - Manual Service Order - Add'l | SOMAN | TBN |
| NRC - Incremental Charge - Manual Service Order - Disconnect | SOMAN | TBN |
| NRC - Incremental Charge - Manual Order Coordination - per loop | TBD | TBN |
| 4-Wire Analog VG Ground-Start Unbundled Sub-Loop Feeder, per month | USBFD | TBN |
| NRC - 1st | USBFD | TBN |
| NRC - Add'l | USBFD | TBN |
| NRC - Disconnect Charge - 1st | USBFD | TBN |
| NRC - Disconnect Charge - Add'l | USBFD | TBN |
| NRC - Incremental Charge - Manual Service Order - 1st | SOMAN | TBN |
| NRC - Incremental Charge - Manual Service Order - Add'l | SOMAN | TBN |
| NRC - Incremental Charge - Manual Service Order - Disconnect | SOMAN | TBN |
| NRC - Incremental Charge - Manual Order Coordination - per loop | TBD | TBN |
| 4-Wire Analog VG Loop-Start Unbundled Sub-Loop Feeder, per month | USBFE | TBN |
| NRC - 1st | USBFE | TBN |
| NRC - Add'l | USBFE | TBN |
| NRC - Disconnect Charge - 1st | USBFE | TBN |
| NRC - Disconnect Charge - Add'l | USBFE | TBN |
| NRC - Incremental Charge - Manual Service Order - 1st | SOMAN | TBN |
| NRC - Incremental Charge - Manual Service Order - Add'l | SOMAN | TBN |
| NRC - Incremental Charge - Manual Service Order - Disconnect | SOMAN | TBN |
| NRC - Incremental Charge - Manual Order Coordination - per loop | TBD | TBN |
| 2-Wire ISDN Unbundled Sub-Loop Feeder, per month | USBFF | TBN |
| NRC - 1st | USBFF | TBN |
| NRC - Add'l | USBFF | TBN |
| NRC - Disconnect Charge - 1st | USBFF | TBN |
| NRC - Disconnect Charge - Add'l | USBFF | TBN |
| NRC - Incremental Charge - Manual Service Order - 1st | SOMAN | TBN |
| NRC - Incremental Charge - Manual Service Order - Add'l | SOMAN | TBN |
| NRC - Incremental Charge - Manual Service Order - Disconnect | SOMAN | TBN |
| NRC - Incremental Charge - Manual Order Coordination - per loop | TBD | TBN |
| 4-Wire DSI Unbundled Sub-Loop Feeder, per month | USBFG | TBN |
| NRC - 1st | USBFG | TBN |
| NRC - Add'l | USBFG | TBN |
| NRC - Disconnect Charge - 1st | USBFG | TBN |
| NRC - Disconnect Charge - Add'l | USBFG | TBN |
| NRC - Incremental Charge - Manual Service Order - 1st | SOMAN | TBN |
| NRC - Incremental Charge - Manual Service Order - Add'l | SOMAN | TBN |
| NRC - Incremental Charge - Manual Service Order - Disconnect | SOMAN | TBN |
| NRC - Incremental Charge - Manual Order Coordination - per loop | TBD | TBN |

BELLSOUTH/ADELPHIA RATES
NETWORK ELEMENTS
AND OTHER SERVICES

| DESCRIPTION | USOC | KY |
|--|-------|-----|
| 2-Wire Copper Unbundled Sub-Loop Feeder, per month | USBFH | TBN |
| NRC - 1st | USBFH | TBN |
| NRC - Add'l | USBFH | TBN |
| NRC - Disconnect Charge - 1st | USBFH | TBN |
| NRC - Disconnect Charge - Add'l | USBFH | TBN |
| NRC - Incremental Charge - Manual Service Order - 1st | SOMAN | TBN |
| NRC - Incremental Charge - Manual Service Order - Add'l | SOMAN | TBN |
| NRC - Incremental Charge - Manual Service Order - Disconnect | SOMAN | TBN |
| NRC - Incremental Charge - Manual Order Coordination - per loop | TBD | TBN |
| 4-Wire Copper Unbundled Sub-Loop Feeder, per month | USBFJ | TBN |
| NRC - 1st | USBFJ | TBN |
| NRC - Add'l | USBFJ | TBN |
| NRC - Disconnect Charge - 1st | USBFJ | TBN |
| NRC - Disconnect Charge - Add'l | USBFJ | TBN |
| NRC - Incremental Charge - Manual Service Order - 1st | SOMAN | TBN |
| NRC - Incremental Charge - Manual Service Order - Add'l | SOMAN | TBN |
| NRC - Incremental Charge - Manual Service Order - Disconnect | SOMAN | TBN |
| NRC - Incremental Charge - Manual Order Coordination - per loop | TBD | TBN |
| 4-Wire 2.4 KBPS Digital Unbundled Sub-Loop Feeder, per month | USBFK | TBN |
| NRC - 1st | USBFK | TBN |
| NRC - Add'l | USBFK | TBN |
| NRC - Disconnect Charge - 1st | USBFK | TBN |
| NRC - Disconnect Charge - Add'l | USBFK | TBN |
| NRC - Incremental Charge - Manual Service Order - 1st | SOMAN | TBN |
| NRC - Incremental Charge - Manual Service Order - Add'l | SOMAN | TBN |
| NRC - Incremental Charge - Manual Service Order - Disconnect | SOMAN | TBN |
| NRC - Incremental Charge - Manual Order Coordination - per loop | TBD | TBN |
| 4-Wire 4.8 KBPS Digital Unbundled Sub-Loop Feeder, per month | USBFL | TBN |
| NRC - 1st | USBFL | TBN |
| NRC - Add'l | USBFL | TBN |
| NRC - Disconnect Charge - 1st | USBFL | TBN |
| NRC - Disconnect Charge - Add'l | USBFL | TBN |
| NRC - Incremental Charge - Manual Service Order - 1st | SOMAN | TBN |
| NRC - Incremental Charge - Manual Service Order - Add'l | SOMAN | TBN |
| NRC - Incremental Charge - Manual Service Order - Disconnect | SOMAN | TBN |
| NRC - Incremental Charge - Manual Order Coordination - per loop | TBD | TBN |
| 4-Wire 9.6 KBPS Digital Unbundled Sub-Loop Feeder, per month | USBFM | TBN |
| NRC - 1st | USBFM | TBN |
| NRC - Add'l | USBFM | TBN |
| NRC - Disconnect Charge - 1st | USBFM | TBN |
| NRC - Disconnect Charge - Add'l | USBFM | TBN |
| NRC - Incremental Charge - Manual Service Order - 1st | SOMAN | TBN |
| NRC - Incremental Charge - Manual Service Order - Add'l | SOMAN | TBN |
| NRC - Incremental Charge - Manual Service Order - Disconnect | SOMAN | TBN |
| NRC - Incremental Charge - Manual Order Coordination - per loop | TBD | TBN |
| 4-Wire 19.2 KBPS Digital Unbundled Sub-Loop Feeder, per month | USBFN | TBN |
| NRC - 1st | USBFN | TBN |
| NRC - Add'l | USBFN | TBN |

BELLSOUTH/ADELPHIA RATES
NETWORK ELEMENTS
AND OTHER SERVICES

| DESCRIPTION | USOC | KY |
|--|-------|----------|
| NRC - Disconnect Charge - 1st | USBFN | TBN |
| NRC - Disconnect Charge - Add'l | USBFN | TBN |
| NRC - Incremental Charge - Manual Service Order - 1st | SOMAN | TBN |
| NRC - Incremental Charge - Manual Service Order - Add'l | SOMAN | TBN |
| NRC - Incremental Charge - Manual Service Order - Disconnect | SOMAN | TBN |
| NRC - Incremental Charge - Manual Order Coordination - per loop | TBD | TBN |
| 4-Wire 56 KBPS Digital Unbundled Sub-Loop Feeder, per month | USBFO | TBN |
| NRC - 1st | USBFO | TBN |
| NRC - Add'l | USBFO | TBN |
| NRC - Disconnect Charge - 1st | USBFO | TBN |
| NRC - Disconnect Charge - Add'l | USBFO | TBN |
| NRC - Incremental Charge - Manual Service Order - 1st | SOMAN | TBN |
| NRC - Incremental Charge - Manual Service Order - Add'l | SOMAN | TBN |
| NRC - Incremental Charge - Manual Service Order - Disconnect | SOMAN | TBN |
| NRC - Incremental Charge - Manual Order Coordination - per loop | TBD | TBN |
| 4-Wire 64 KBPS Digital Unbundled Sub-Loop Feeder, per month | USBFP | TBN |
| NRC - 1st | USBFP | TBN |
| NRC - Add'l | USBFP | TBN |
| NRC - Disconnect Charge - 1st | USBFP | TBN |
| NRC - Disconnect Charge - Add'l | USBFP | TBN |
| NRC - Incremental Charge - Manual Service Order - 1st | SOMAN | TBN |
| NRC - Incremental Charge - Manual Service Order - Add'l | SOMAN | TBN |
| NRC - Incremental Charge - Manual Service Order - Disconnect | SOMAN | TBN |
| NRC - Incremental Charge - Manual Order Coordination - per loop | TBD | TBN |
| Unbundled Sub-Loop Modification | | |
| NRC - Load Coil/Equipment Removal per 2 Wire pair | ULM2X | TBN |
| NRC - Load Coil/Equipment Removal per 4 Wire pair | ULM4X | TBN |
| NRC - Bridge Tap Removal per pair unloaded | ULMBT | TBN |
| Loop Make Up | | |
| NRC - Loop Makeup - Preordering Without Reservation, per working facility queried (Manual) | UMKLW | \$134.00 |
| Loop Makeup - Preordering Without Reservation, per spare facility queried (Manual) Maximum number of spare facilities per manual LMUSI is (3).] | UMKLW | \$134.00 |
| NRC - Loop Makeup - Preordering With Reservation, per spare facility queried (Manual) Maximum number of spare facilities per manual LMUSI is (3).] | UMKLP | \$140.00 |
| NRC - Loop Makeup - Preordering Without Reservation, per working facility queried (Mechanized) | TBD | \$1.08 |
| Loop Makeup - Preordering Without Reservation, per spare facility queried (Mechanized) Maximum number of spare facilities per mechanized LMUSI is (10).] | TBD | \$1.08 |
| Loop Makeup - Preordering With Reservation, per spare facility queried (Mechanized) Maximum number of spare facilities per mechanized LMUSI is (10).] | TBD | \$1.08 |
| Unbundled Network Terminating Wire, per pair, per month | UENPP | TBN |
| NRC - UNTW Pair, per pair | UENPP | TBN |
| NRC - Disconnect Charge, per pair | UENPP | TBN |
| NRC - Incremental Charge - Manual Service Order | SOMAN | TBN |

BELLSOUTH/ADELPHIA RATES
NETWORK ELEMENTS
AND OTHER SERVICES

| DESCRIPTION | USOC | KY |
|--|-------|------------|
| NRC - Incremental Charge - Manual Service Order - Disconnect | SOMAN | TBN |
| Sub-Loop Concentration - Channelization Sys (Outside CO) | | |
| NRC - Incremental Charge - Manual Service Order - 1st | SOMAN | TBD |
| NRC - Incremental Charge - Manual Service Order - Add'l | SOMAN | TBD |
| TR008 - System A (96 channel capacity - channels 1-96), per month | UCT8A | \$757.00 |
| NRC - 1st | UCT8A | \$633.94 |
| NRC - Add'l | UCT8A | \$311.60 |
| TR008 - System B (96 channel capacity - channels 97-192), per month | UCT8B | \$95.60 |
| NRC - 1st | UCT8B | \$633.94 |
| NRC - Add'l | UCT8B | \$311.60 |
| TR303 - System A (96 channel capacity - channels 1-96), per month | UCT3A | \$799.95 |
| NRC - 1st | UCT3A | \$633.94 |
| NRC - Add'l | UCT3A | \$311.60 |
| TR303 - System B (96 channel capacity - channels 97-192), per month | UCT3B | \$138.55 |
| NRC - 1st | UCT3B | \$633.94 |
| NRC - Add'l | UCT3B | \$311.60 |
| DS1 Feeder Interface, per month | UCTFS | \$77.02 |
| NRC 1st | UCTFS | \$418.13 |
| NRC Add'l | UCTFS | \$198.56 |
| Channel Interface - 2 Wire Voice - Loop Start , per month | TBD | \$2.68 |
| NRC 1st | TBD | \$41.92 |
| NRC Add'l | TBD | \$41.69 |
| Channel Interface - 2 Wire ISDN, per month | ULCC1 | \$10.72 |
| NRC 1st | ULCC1 | \$41.92 |
| NRC Add'l | ULCC1 | \$41.69 |
| Channel Interface - 2 Wire Voice - Ground Start or Reverse Battery, per month | TBD | \$15.94 |
| NRC 1st | TBD | \$41.92 |
| NRC Add'l | TBD | \$41.69 |
| Channel Interface - 4 Wire Voice, per month | ULCC4 | \$9.50 |
| NRC 1st | ULCC4 | \$41.92 |
| NRC Add'l | ULCC4 | \$41.69 |
| Test Circuit, per month | UCTTC | \$46.44 |
| NRC 1st | UCTTC | \$41.92 |
| NRC Add'l | UCTTC | \$41.69 |
| Channel Interface - Digital 56Kbps, per month | ULCC5 | \$14.08 |
| NRC 1st | ULCC5 | \$41.92 |
| NRC Add'l | ULCC5 | \$41.69 |
| Channel Interface - Digital 64Kbps, per month | ULCC6 | \$14.08 |
| NRC 1st | ULCC6 | \$41.92 |
| NRC Add'l | ULCC6 | \$41.69 |
| Loop Concentration System (Inside C.O.) | | |
| NRC - Incremental Charge - Manual Service Order - 1st | SOMAN | TBD |
| NRC - Incremental Charge - Manual Service Order - Add'l | SOMAN | TBD |
| TR008 - System A (96 channel capacity - channels 1-96), per month | UCT8A | \$394.00 |
| NRC - 1st | UCT8A | \$1,116.15 |
| NRC - Add'l | UCT8A | NA |
| TR008 - System B (96 channel capacity - channels 97-192), per month | UCT8B | \$72.21 |
| NRC - 1st | UCT8B | \$465.11 |
| NRC - Add'l | UCT8B | NA |
| TR303 - System A (96 channel capacity - channels 1-96), per month | UCT3A | \$445.14 |
| NRC - 1st | UCT3A | \$1,116.15 |
| NRC - Add'l | UCT3A | NA |

BELLSOUTH/ADELPHIA RATES
NETWORK ELEMENTS
AND OTHER SERVICES

| DESCRIPTION | USOC | KY |
|--|-------|----------|
| TR303 - System B (96 channel capacity - channels 97-192), per month | UCT3B | \$121.45 |
| NRC - 1st | UCT3B | \$465.11 |
| NRC - Add'l | UCT3B | NA |
| DS1 Interface, per month | UCTCO | \$403.20 |
| NRC 1st | UCTCO | \$132.18 |
| NRC Add'l | UCTCO | \$132.18 |
| Channel Interface - 2 Wire Voice - Loop Start , per month | TBD | \$2.79 |
| NRC 1st | TBD | \$35.82 |
| NRC Add'l | TBD | \$35.62 |
| Channel Interface - 2 Wire ISDN, per month | ULCC1 | \$11.18 |
| NRC 1st | ULCC1 | \$35.82 |
| NRC Add'l | ULCC1 | \$35.62 |
| Channel Interface - 2 Wire Voice - Ground Start or Reverse Battery, per month | TBD | \$16.62 |
| NRC 1st | TBD | \$35.82 |
| NRC Add'l | TBD | \$35.62 |
| Channel Interface - 4 Wire Voice, per month | ULCC4 | \$9.91 |
| NRC 1st | ULCC4 | \$35.82 |
| NRC Add'l | ULCC4 | \$35.62 |
| Test Circuit, per month | UCTTC | \$48.43 |
| NRC 1st | UCTTC | \$35.82 |
| NRC Add'l | UCTTC | \$35.62 |
| Channel Interface - Digital 56Kbps, per month | ULCC5 | TBN |
| NRC 1st | ULCC5 | TBN |
| NRC Add'l | ULCC5 | TBN |
| Channel Interface - Digital 64Kbps, per month | ULCC6 | TBN |
| NRC 1st | ULCC6 | TBN |
| NRC Add'l | ULCC6 | TBN |
| LINE SHARING | | |
| System Splitter - 96 Line Capacity | | |
| RC - Per month | ULSDA | \$100.00 |
| NRC - 1st | ULSDA | \$300.00 |
| NRC - Add'l | ULSDA | \$0.00 |
| NRC - Disconnect | ULSDA | NA |
| System Splitter - 24 Line Capacity | | |
| RC - Per month | ULSDB | \$25.00 |
| NRC - 1st | ULSDB | \$300.00 |
| NRC - Add'l | ULSDB | \$0.00 |
| NRC - Disconnect | ULSDB | NA |
| Loop Capacity, Line Activation Per Occurrence | | |
| RC - Per Month | ULSDC | \$6.00 |
| NRC - 1st | ULSDC | \$40.00 |
| NRC - Add'l | ULSDC | \$22.00 |
| Subsequent Activity - Per Occurrence | | |
| NRC - 1st | ULSDS | \$30.00 |
| NRC - Add'l | ULSDS | \$15.00 |
| NRC - Incremental Charge - Manual Service Order - 1st | | |
| | SOMAN | \$47.00 |
| NRC - Incremental Charge - Manual Service Order - Add'l | | |
| | SOMAN | \$21.00 |
| NRC - Incremental Charge - Manual Service Order - Disconnect - 1st | | |
| | SOMAN | \$17.77 |

BELLSOUTH/ADELPHIA RATES
 NETWORK ELEMENTS
 AND OTHER SERVICES

| DESCRIPTION | | | | USOC | KY |
|-------------|--|--|--|-------|---------|
| | | | NRC - Incremental Charge - Manual Service Order - Disconnect - Add'l | SOMAN | \$17.77 |
| | | | NRC - Electronic Svc Order, per LSR | SOMEK | \$3.50 |
| | | | NRC - Electronic Svc Order, per LSR disconnect | SOMEK | NA |
| | | | | | |
| | | | * Rates subject to true-up | | |
| | | | | | |
| | | | | | |

BELLSOUTH/ADELPHIA RATES
NETWORK ELEMENTS
AND OTHER SERVICES

| DESCRIPTION | | KY |
|--|---|---------------------|
| LOCAL EXCHANGE SWITCHING (PORTS) | | |
| 2-Wire Analog Line Port (Res., Bus.), per month | | |
| | | |
| 2-Wire Voice Grade Line Port (Residence), per month | | |
| | | |
| | 2-wire voice unbundled port - residence | UEPRL 2.61 - Note 1 |
| | 2-wire voice unbundled port with caller ID - residence | UEPRC \$2.61 |
| | 2-wire voice unbundled port outgoing only - residence | UEPRO \$2.61 |
| | 2-wire voice grade unbundled Alabama extended local dialing parity port with caller ID | UEPAR NA |
| | 2-wire voice grade unbundled Kentucky extended local dialing parity port with caller ID | UEPRM \$2.61 |
| | 2-wire voice grade unbundled Louisiana extended local dialing parity port with caller ID | UEPAS NA |
| | 2-wire voice grade unbundled Mississippi extended local dialing parity port with caller ID | UEPAT NA |
| | 2-wire voice grade unbundled South Carolina extended local dialing parity port with caller ID | UEPAU NA |
| | 2-wire voice grade unbundled Tennessee extended local dialing parity port with caller ID | UEPAQ NA |
| | 2-wire voice unbundled Florida area calling with caller ID - residence | UEPAF NA |
| | 2-wire voice unbundled Louisiana Area Plus with caller ID - residence (RUL) | UEPAG NA |
| | 2-wire voice unbundled Louisiana Area Plus with caller ID - residence (AC7) | UEPAH NA |
| | 2-wire voice unbundled South Carolina Area Calling port with Caller ID - residence (LW8) | UEPAJ NA |
| | 2-wire voice unbundled Tennessee Area Calling port with Caller ID - residence (F2R) | UEPAK NA |
| | 2-wire voice unbundled Tennessee Area Calling port with Caller ID - residence (TACER) | UEPAL NA |
| | 2-wire voice unbundled Tennessee Area Calling port with Caller ID - residence (TACSR) | UEPAM NA |
| | 2-wire voice unbundled Tennessee Area Calling port with Caller ID - residence (1MF2X) | UEPAN NA |
| | 2-wire voice unbundled Tennessee Area Calling port with Caller ID - residence (2MR) | UEPAO NA |
| | 2-wire voice unbundled res, low usage line port with Caller ID (LUM) | UEPAP \$2.61 |
| | | |
| | LOCAL NUMBER PORTABILITY (REQUIRES ONE PER PORT) | LNPCX |
| | | |
| 2-Wire Voice Grade Line Port(Business), per month | | |
| | | |
| | 2-wire voice unbundled port without Caller ID | UEPBL \$2.61 |
| | 2-wire voice unbundled port with unbundled port with Caller+E484 ID | UEPBC \$2.61 |
| | 2-wire voice unbundled outgoing only port | UEPBO \$2.61 |
| | 2-wire voice grade unbundled Alabama extended local dialing parity port with caller ID | UEPAW NA |
| | 2-wire voice grade unbundled Kentucky extended local dialing parity port with caller ID | UEPBM \$2.61 |
| | 2-wire voice grade unbundled Louisiana extended local dialing parity port with caller ID | UEPAX NA |
| | 2-wire voice grade unbundled Mississippi extended local dialing parity port with caller ID | UEPAY NA |
| | 2-wire voice grade unbundled South Carolina extended local dialing parity port with caller ID | UEPAZ NA |
| | 2-wire voice grade unbundled Tennessee extended local dialing parity port with caller ID | UEPAV NA |
| | 2-wire voice unbundled incoming only port with Caller ID | UEPB1 \$2.61 |
| | 2-wire voice unbundled LA Bus Area Calling Port with Caller ID (BUC) | UEPAA NA |

BELLSOUTH/ADELPHIA RATES
NETWORK ELEMENTS
AND OTHER SERVICES

| DESCRIPTION | | KY |
|--|-------|---------|
| 2-wire voice unbundled SC Bus Area Calling Port with Caller ID (LMB) | UEPAB | NA |
| 2-wire voice unbundled TN Bus 2-Way Area Calling Port Economy Option (TACC1) | UEPAC | NA |
| 2-wire voice unbundled TN Bus 2-Way Area Calling Port Standard Option (TACC2) | UEPAD | NA |
| 2-wire voice unbundled TN Bus 2-WAY Collierville and Memphis Local Calling Port (B2F) | UEPAE | NA |
| LOCAL NUMBER PORTABILITY (REQUIRES ONE PER PORT) | LNPCX | |
| Non-Recurring Charges (NRC) - 1st (Residence) | | |
| 2- wire voice unbundled port - residence | UEPRL | \$37.78 |
| 2-wire voice unbundled port with caller ID - residence | UEPRC | \$37.78 |
| 2-wire voice unbundled port outgoing only - residence | UEPRO | \$37.78 |
| 2-wire voice unbundled area plus port with caller ID - residence | UEPRM | \$37.78 |
| 2-wire voice unbundled Florida area calling with caller ID - residence | UEPAF | NA |
| 2-wire voice unbundled Louisiana Area Plus with caller ID - residence (RUL) | UEPAG | NA |
| 2-wire voice unbundled Louisiana Area Plus with caller ID - residence (AC7) | UEPAH | NA |
| 2-wire voice unbundled South Carolina Area Calling port with Caller ID - residence (LW8) | UEPAJ | NA |
| 2-wire voice unbundled Tennessee Area Calling port with Caller ID - residence (F2R) | UEPAK | NA |
| 2-wire voice unbundled Tennessee Area Calling port with Caller ID - residence (TACER) | UEPAL | NA |
| 2-wire voice unbundled Tennessee Area Calling port with Caller ID - residence (TACSR) | UEPAM | NA |
| 2-wire voice unbundled Tennessee Area Calling port with Caller ID - residence (1MF2X) | UEPAN | NA |
| 2-wire voice unbundled Tennessee Area Calling port with Caller ID - residence (2MR) | UEPAO | NA |
| 2-wire voice unbundled Res Low Usage Line Port with Caller+E563 ID (LUM) | UEPAP | \$37.78 |
| NRC - Add'l (Residence) | | |
| 2- wire voice unbundled port - residence - | UEPRL | \$37.78 |
| 2-wire voice unbundled port with caller ID - residence | UEPRC | \$37.78 |
| 2-wire voice unbundled port outgoing only - residence | UEPRO | \$37.78 |
| 2-wire voice unbundled area plus port with caller ID - residence | UEPRM | \$37.78 |
| 2-wire voice unbundled Florida area calling with caller ID - residence | UEPAF | NA |
| 2-wire voice unbundled Louisiana Area Plus with caller ID - residence (RUL) | UEPAG | NA |
| 2-wire voice unbundled Louisiana Area Plus with caller ID - residence (AC7) | UEPAH | NA |
| 2-wire voice unbundled South Carolina Area Calling port with Caller ID - residence (LW8) | UEPAJ | NA |
| 2-wire voice unbundled Tennessee Area Calling port with Caller ID - residence (F2R) | UEPAK | NA |
| 2-wire voice unbundled Tennessee Area Calling port with Caller ID - residence (TACER) | UEPAL | NA |

BELLSOUTH/ADELPHIA RATES
NETWORK ELEMENTS
AND OTHER SERVICES

| DESCRIPTION | | | KY |
|-------------|---|-------|---------|
| | 2-wire voice unbundled Tennessee Area Calling port with Caller ID - residence (TACSR) | UEPAM | NA |
| | 2-wire voice unbundled Tennessee Area Calling port with Caller ID - residence (1MF2X) | UEPAN | NA |
| | 2-wire voice unbundled Tennessee Area Calling port with Caller ID - residence (2MR) | UEPAO | NA |
| | 2-wire voice unbundled Res Low Usage Line Port with Caller ID (LUM) | UEPAP | \$37.78 |
| | NRC - Subsequent Activity | USASC | \$10.00 |
| | NRC - 1st (Business) | | |
| | 2-wire Voice Unbundled Port without Caller ID | UEPBL | \$37.55 |
| | 2-wire voice unbundled port with Caller ID | UEPBC | \$37.55 |
| | 2-wire voice unbundled outgoing only port | UEPBO | \$37.55 |
| | 2-wire voice unbundled Area Plus Port with Caller ID | UEPBM | \$37.55 |
| | 2-wire voice unbundled Incoming only Port with Caller ID | UEPB1 | \$37.55 |
| | 2-wire voice unbundled LA Bus Area Calling Port with Caller ID (BUC) | UEPAA | NA |
| | 2-wire voice unbundled SC Bus Area Calling Port with Caller ID+E587 (LMB) | UEPAB | NA |
| | 2-wire voice unbundled TN Bus 2-way Area Calling Port Economy Option (TACC1) | UEPAC | NA |
| | 2-wire voice unbundled TN Bus 2-way Area Calling Port Standard Option (TACC2) | UEPAD | NA |
| | 2-wire voice unbundled TN Bus 2-way Collierville and Memphis Local Calling Port (B2F) | UEPAE | NA |
| | NRC - Add'l (Business) | UEPBL | \$37.55 |
| | 2-wire voice unbundled port without Caller ID | UEPBL | \$37.55 |
| | 2-wire voice unbundled port with Caller ID | UEPBC | \$37.55 |
| | 2-wire voice unbundled outgoing only port | UEPBO | \$37.55 |
| | 2-wire voice unbundled Area Plus Port with Caller ID | UEPBM | \$37.55 |
| | 2-wire voice unbundled incoming only port with Caller ID | UEPB1 | \$37.55 |
| | 2-wire voice unbundled LA Bus Area Calling Port with Caller ID (BUC) | UEPAA | NA |
| | 2-wire voice unbundled SC Bus Area Calling Port with Caller ID (LMB) | UEPAB | NA |
| | 2-wire voice unbundled TN Bus 2-way Area Calling Port Economy Option (TACC1) | UEPAC | NA |
| | 2-wire voice unbundled TN Bus 2-way Area Calling Port Standard Option (TACC2) | UEPAD | NA |
| | 2-wire voice unbundled TN Bus 2-way Collierville and Memphis Local Calling Port (B2F) | UEPAE | NA |
| | NRC - Subsequent Activity | USASC | \$10.00 |

BELLSOUTH/ADELPHIA RATES
 NETWORK ELEMENTS
 AND OTHER SERVICES

| DESCRIPTION | KY |
|--|----|
| NRC - Disconnect Charge - 1st | |
| 2- wire voice unbundled port - residence | NA |
| 2-wire voice unbundled port with caller ID - residence | NA |
| 2-wire voice unbundled port outgoing only - residence | NA |
| 2-wire voice unbundled area plus port with caller ID - residence | NA |
| 2-wire voice unbundled Florida area calling with caller ID - residence | NA |
| 2-wire voice unbundled Louisiana Area Plus with caller ID - residence (RUL) | NA |
| 2-wire voice unbundled Louisiana Area Plus with caller ID - residence (AC7) | NA |
| 2-wire voice unbundled South Carolina Area Calling port with Caller ID - residence (LW8) | NA |
| 2-wire voice unbundled Tennessee Area Calling port with Caller ID - residence (F2R) | NA |
| 2-wire voice unbundled Tennessee Area Calling port with Caller ID - residence (TACER) | NA |
| 2-wire voice unbundled Tennessee Area Calling port with Caller ID - residence (TACSR) | NA |
| 2-wire voice unbundled Tennessee Area Calling port with Caller ID - residence (1MF2X) | NA |
| 2-wire voice unbundled Tennessee Area Calling port with Caller ID - residence (2MR) | NA |
| 2-wire voice unbundled Res Low Usage Line Port with Caller ID (LUM) | NA |
| 2-wire voice unbundled port without Caller ID | NA |
| 2-wire voice unbundled port with Caller ID | NA |
| 2-wire voice unbundled outgoing only Port | NA |
| 2-wire voice unbundled Area Plus Port with Caller ID | NA |
| 2-wire voice unbundled Incoming only Port with Caller ID | NA |
| 2-wire voice unbundled LA Bus Area Calling Port with Caller ID (BUC) | NA |
| 2-wire voice unbundles SC Bus Area Calling Port with Caller ID (LMB) | NA |
| 2-wire voice unbundled TN Bus 2-way Area Calling Port Economy Option (TACC1) | NA |
| 2-wire voice unbundled TN Bus 2-way Area Calling Port Standard Option (TACC2) | NA |
| 2-wire voice unbundled TN Bus 2-Way Collierville and Memphis Local Calling Port (B2F) | NA |
| NRC - Disconnect Charge - Add'l | |
| 2- wire voice unbundled port - residence | NA |
| 2-wire voice unbundled port with caller ID - residence | NA |
| 2-wire voice unbundled port outgoing only - residence | NA |
| 2-wire voice unbundled area plus port with caller ID - residence | NA |
| 2-wire voice unbundled Florida area calling with caller ID - residence | NA |
| 2-wire voice unbundled Louisiana Area Plus with caller ID - residence (RUL) | NA |
| 2-wire voice unbundled Louisiana Area Plus with caller ID - residence (AC7) | NA |
| 2-wire voice unbundled South Carolina Area Calling port with Caller ID - residence (LW8) | NA |
| 2-wire voice unbundled Tennessee Area Calling port with Caller ID - residence (F2R) | NA |
| 2-wire voice unbundled Tennessee Area Calling port with Caller ID - residence (TACER) | NA |
| 2-wire voice unbundled Tennessee Area Calling port with Caller ID - residence (TACSR) | NA |
| 2-wire voice unbundled Tennessee Area Calling port with Caller ID - residence (1MF2X) | NA |

BELLSOUTH/ADELPHIA RATES
NETWORK ELEMENTS
AND OTHER SERVICES

| DESCRIPTION | | | KEY |
|-------------|--|---|--------------|
| | | 2-wire voice unbundled Tennessee Area Calling port with Caller ID - residence (2MR) | NA |
| | | 2-wire voice unbundled Res Low Usage Line Port with Caller ID (LUM) | NA |
| | | 2-wire voice unbundled port without Caller ID | NA |
| | | 2-wire voice unbundled port with Caller ID | NA |
| | | 2-wire voice unbundled outgoing only port | NA |
| | | 2-wire voice unbundled Area Plus Port with Caller ID | NA |
| | | 2-wire voice unbundled incoming only port with Caller ID | NA |
| | | 2-wire voice unbundled LA Bus Area Calling Port with Caller ID (BUC) | NA |
| | | 2-wire voice unbundled SC Bus Area Calling Port with Caller ID (LMB) | NA |
| | | 2-wire voice unbundled TN Bus 2-way Area Calling Port Economy Option (TACC1) | NA |
| | | 2-wire voice unbundled TN Bus 2-way Area Calling Port Standard Option (TACC2) | NA |
| | | 2-wire voice unbundled TN Bus 2-way Collierville and Memphis Local Calling Port (B2F) | NA |
| | | NRC - OSS LSR Charge, Electronic, per LSR received from the CLEC by one of the OSS interactive interfaces | SOMEK \$3.50 |
| | | NRC - Incremental Charge - Manual Service Order - 1st | SOMAN NA |
| | | NRC - Incremental Charge - Manual Service Order - Add'l | SOMAN NA |
| | | NRC - Incremental Charge - Manual Service Order - Disconnect - 1st | SOMAN NA |
| | | NRC - Incremental Charge - Manual Service Order - Disconnect - Add'l | SOMAN NA |
| | | All available features, per month | UEPVF NA |
| | | NRC - 1st (all types) | NA |
| | | NRC - Add'l (all types) | NA |
| | | NRC - Disconnect Charge - 1st | NA |
| | | NRC - Disconnect Charge - Add'l | NA |
| | | NRC - Incremental Charge - Manual Service Order - 1st | SOMAN NA |
| | | NRC - Incremental Charge - Manual Service Order - Add'l | SOMAN NA |
| | | NRC - Incremental Charge - Manual Service Order - Disconnect - 1st | SOMAN NA |
| | | NRC - Incremental Charge - Manual Service Order - Disconnect - Add'l | SOMAN NA |
| | | Three available feature, per month | UEPVF NA |
| | | NRC - 1st (all types) | NA |
| | | NRC - Add'l (all types) | NA |
| | | NRC - Disconnect Charge - 1st | NA |
| | | NRC - Disconnect Charge - Add'l | NA |
| | | NRC - Incremental Charge - Manual Service Order - 1st | SOMAN NA |
| | | NRC - Incremental Charge - Manual Service Order - Add'l | SOMAN NA |
| | | NRC - Incremental Charge - Manual Service Order - Disconnect - 1st | SOMAN NA |
| | | NRC - Incremental Charge - Manual Service Order - Disconnect - Add'l | SOMAN NA |
| | | 4-Wire Analog VG Port, per month | UEP4A NA |
| | | NRC - 1st | UEP4A NA |
| | | NRC - Add'l | UEP4A NA |
| | | NRC - Disconnect Charge - 1st | BFR NA |
| | | NRC - Disconnect Charge - Add'l | BFR NA |
| | | NRC - Incremental Charge - Manual Service Order - 1st | SOMAN NA |
| | | NRC - Incremental Charge - Manual Service Order - Add'l | SOMAN NA |
| | | NRC - Incremental Charge - Manual Service Order - Disconnect - 1st | SOMAN NA |
| | | 2-Wire DID Port, per month | UEPP2 NA |
| | | NRC - 1st | UEPP2 NA |

BELLSOUTH/ADELPHIA RATES
NETWORK ELEMENTS
AND OTHER SERVICES

| DESCRIPTION | | | UE | KY |
|--|--|--|-------|----------|
| | | NRC - Add'l | UEPP2 | NA |
| | | NRC - Disconnect Charge - 1st | UEPP2 | NA |
| | | NRC - Disconnect Charge - Add'l | UEPP2 | NA |
| | | NRC - Incremental Charge - Manual Service Order - 1st | SOMAN | NA |
| | | NRC - Incremental Charge - Manual Service Order - Add'l | SOMAN | NA |
| | | NRC - Incremental Charge - Manual Service Order - Disconnect - 1st | SOMAN | NA |
| 4-Wire DS1 Port w/DID capability, per month | | | UEPDD | NA |
| | | NRC - 1st | UEPDD | NA |
| | | NRC - Add'l | UEPDD | NA |
| | | NRC - Disconnect Charge - 1st | UEPDD | NA |
| | | NRC - Disconnect Charge - Add'l | UEPDD | NA |
| | | NRC - Incremental Charge - Manual Service Order - 1st | SOMAN | NA |
| | | NRC - Incremental Charge - Manual Service Order - Add'l | SOMAN | NA |
| | | NRC - Incremental Charge - Manual Service Order - Disconnect - 1st | SOMAN | NA |
| 2-Wire ISDN Port(2) (3), per month | | | U1PMA | \$12.33 |
| | | NRC - 1st | U1PMA | \$90.48 |
| | | NRC - Add'l | U1PMA | \$84.53 |
| | | NRC - Disconnect Charge - 1st | U1PMA | NA |
| | | NRC - Disconnect Charge - Add'l | U1PMA | NA |
| | | NRC - Incremental Charge - Manual Service Order - 1st | SOMAN | NA |
| | | NRC - Incremental Charge - Manual Service Order - Add'l | SOMAN | NA |
| | | NRC - Incremental Charge - Manual Service Order - Disconnect - 1st | SOMAN | NA |
| | | NRC - Incremental Charge - Manual Service Order - Disconnect - Add'l | SOMAN | NA |
| | | NRC - User Profile per B Channel (4) | U1UMA | \$5.61 |
| 2-Wire ISDN Port(2) (3) including all available features, per month | | | U1PMA | NA |
| | | NRC - 1st | U1PMA | NA |
| | | NRC - Add'l | U1PMA | NA |
| | | NRC - Incremental Charge - Manual Service Order - 1st | SOMAN | NA |
| | | NRC - Incremental Charge - Manual Service Order - Add'l | SOMAN | NA |
| 2-Wire ISDN Port(2) (3) including three available features, per month | | | U1PMA | NA |
| | | NRC - 1st | U1PMA | NA |
| | | NRC - Add'l | U1PMA | NA |
| | | NRC - Incremental Charge - Manual Service Order - 1st | SOMAN | NA |
| | | NRC - Incremental Charge - Manual Service Order - Add'l | SOMAN | NA |
| 4-Wire ISDN DS1 Port, per month | | | UEPEX | NA |
| | | NRC - 1st | UEPEX | NA |
| | | NRC - Add'l | UEPEX | NA |
| | | NRC - Disconnect Charge - 1st | UEPEX | NA |
| | | NRC - Disconnect Charge - Add'l | UEPEX | NA |
| | | NRC - Incremental Charge - Manual Service Order - 1st | SOMAN | NA |
| | | NRC - Incremental Charge - Manual Service Order - Add'l | SOMAN | NA |
| | | NRC - Incremental Charge - Manual Service Order - Disconnect - 1st | SOMAN | NA |
| | | NRC - Incremental Charge - Manual Service Order - Disconnect - Add'l | SOMAN | NA |
| 4-Wire ISDN DS1 Port including all available features, per month | | | UEPEX | \$275.48 |
| | | NRC - 1st | UEPEX | \$181.27 |
| | | NRC - Add'l | UEPEX | \$116.42 |
| | | NRC - Incremental Charge - Manual Service Order - 1st | SOMAN | NA |
| | | NRC - Incremental Charge - Manual Service Order - Add'l | SOMAN | NA |

BELLSOUTH/ADELPHIA RATES
NETWORK ELEMENTS
AND OTHER SERVICES

| DESCRIPTION | | KY |
|--|--------|--------|
| 2-Wire Analog Line Port (PBX), per month | | |
| 2 WIRE VOICE UNBUNDLED COMBINATION 2-WAY PBX TRUNK - Residence | UEPRD | \$2.61 |
| LINE SIDE UNBUNDLED COMBINATION 2-WAY PBX TRUNK - BUSINESS | UEPPC | \$2.61 |
| LINE SIDE UNBUNDLED OUTWARD PBX TRUNK - BUSINESS | UEPPO | \$2.61 |
| LINE SIDE UNBUNDLED INCOMING PBX TRUNK - BUSINESS | UEPP1 | \$2.61 |
| LONG DISTANCE TERMINAL PBX TRUNK-BUSINESS | UEPLD | \$2.61 |
| TN 2-WAY CALLING PLAN PBX TRUNK - BUSINESS | UEPT2 | \$2.61 |
| TN OUTWARD CALLING PLAN PBX TRUNK - BUSINESS | UEPTO | \$2.61 |
| 2-WIRE VOICE UNBUNDLED 2-WAY COMBINATION PBX ALABAMA CALLING PORT | UEPA2 | NA |
| 2-WIRE VOICE UNBUNDLED 2-WAY COMBINATION PBX LOUISIANA CALLING PORT | UEPL2 | NA |
| 2-WIRE VOICE UNBUNDLED PBX LD TERMINAL PORTS | UEPLD | \$2.61 |
| 2-WIRE VOICE UNBUNDLED 2-WAY COMBINATION PBX TENNESSEE CALLING PORT | UEPT2 | NA |
| 2-WIRE VOICE UNBUNDLED 1-WAY OUTGOING PBX TENNESSEE CALLING PORT | UEPTO | NA |
| 2-WIRE VOICE UNBUNDLED 2-WAY COMBINATION PBX USAGE PORT | UEPXA | \$2.61 |
| 2-WIRE VOICE UNBUNDLED PBX TOLL TERMINAL HOTEL PORTS | UEPXB | \$2.61 |
| 2-WIRE VOICE UNBUNDLED PBX LD DDD TERMINALS PORT | UEPXC | \$2.61 |
| 2-WIRE VOICE UNBUNDLED PBX LD TERMINAL SWITCHBOARD PORT | UEPXD | \$2.61 |
| 2-WIRE VOICE UNBUNDLED PBX LD TERMINAL SWITCHBOARD IDD CAPABLE PORT | UEPXE | \$2.61 |
| 2-WIRE VOICE UNBUNDLED 2-WAY PBX KENTUCKY ROOM AREA CALLING PORT WITHOUT LUD | UEPXF | \$2.61 |
| 2-WIRE VOICE UNBUNDLED PBX KENTUCKY LUD AREA CALLING PORT | UEPXG | \$2.61 |
| 2-WIRE VOICE UNBUNDLED PBX KENTUCKY PREMIUM CALLING PORT | UEPXH | \$2.61 |
| 2-WIRE VOICE UNBUNDLED 2-WAY KENTUCKY AREA CALLING PORT WITHOUT LUD | UEPXJ | \$2.61 |
| 2-WIRE VOICE UNBUNDLED 2-WAY PBX LOUISIANA LOCAL OPTIONAL CALLING PORT | UEP XK | NA |
| 2-WIRE VOICE UNBUNDLED 2-WAY PBX HOTEL/HOSPITAL ECONOMY ADMINISTRATIVE CALLING PORT | UEPXL | \$2.61 |
| 2-WIRE VOICE UNBUNDLED 2-WAY PBX HOTEL/HOSPITAL ECONOMY ROOM CALLING PORT | UEPXM | \$2.61 |
| 2-WIRE VOICE UNBUNDLED 1-WAY OUTGOING PBX HOTEL/HOSPITAL ECONOMY ADMINIATRATIVE CALLING PORTTENNESSEE CALLING PORT | UEPXN | NA |
| 2-WIRE VOICE UNBUNDLED 1-WAY OUTGOING PBX HOTEL/HOSPITAL DIACOUNT ROOM CALLING PORT | UEPXO | \$2.61 |
| 2-WIRE VOICE UNBUNDLED 1-WAY OUTGOING PBX LOUISIANA LOCAL DISCOUNT CALLING PORT | UEPXP | NA |
| 2-WIRE VOICE UNBUNDLED 2-WAY PBX MISSISSIPPI LOCAL ECONOMY CALLING PORT | UEPXQ | NA |
| 2-WIRE VOICE UNBUNDLED 2-WAY PBX MISSISSIPPI LOCAL OPTIONAL CALLING PORT | UEPXR | NA |
| 2-WIRE VOICE UNBUNDLED 1-WAY OUTGOING PBXMEASURED PORT | UEPXS | \$2.61 |
| 2-WIRE VOICE UNBUNDLED 2-WAY PBX SOUTH CAROLINA AREA PLUS CALLING PORT | UEPXT | NA |
| 2-WIRE VOICE UNBUNDLED PBX COLLIERVILLE & MEMPHIS CALLING PORT | UEPXU | NA |

BELLSOUTH/ADELPHIA RATES
NETWORK ELEMENTS
AND OTHER SERVICES

| DESCRIPTION | | | KEY |
|-------------|--|--|---------------|
| | | 2-WIRE VOICE UNBUNDLED 2-WAY PBX TENNESSEE REGIONSERV CALLING PORT | UEPXV NA |
| | | UNBUNDLED LOOP BILLING USOC (REQUIRES ONE PER PORT) | UEPLX |
| | | LOCAL NUMBER PORTABILITY (REQUIRES ONE PER PORT) | LNPCP |
| | | NRC - 1st | UEPPC \$36.47 |
| | | 2 WIRE VOICE UNBUNDLED COMBINATION 2-WAY PBX TRUNK - Residence | UEPRD \$36.47 |
| | | LINE SIDE UNBUNDLED COMBINATION 2-WAY PBX TRUNK - BUSINESS | UEPPC \$36.47 |
| | | LINE SIDE UNBUNDLED OUTWARD PBX TRUNK - BUSINESS | UEPPO \$36.47 |
| | | LINE SIDE UNBUNDLED INCOMING PBX TRUNK - BUSINESS | UEPP1 \$36.47 |
| | | LONG DISTANCE TERMINAL PBX TRUNK-BUSINESS | UEPLD \$36.47 |
| | | TN 2-WAY CALLING PLAN PBX TRUNK - BUSINESS | UEPT2 \$36.47 |
| | | TN OUTWARD CALLING PLAN PBX TRUNK - BUSINESS | UEPTO \$36.47 |
| | | 2-WIRE VOICE UNBUNDLED 2-WAY COMBINATION PBX ALABAMA CALLING PORT | UEPA2 NA |
| | | 2-WIRE VOICE UNBUNDLED 2-WAY COMBINATION PBX LOUISIANA CALLING PORT | UEPL2 NA |
| | | 2-WIRE VOICE UNBUNDLED PBX LD TERMINAL PORTS | UEPLD \$36.47 |
| | | 2-WIRE VOICE UNBUNDLED 2-WAY COMBINATION PBX TENNESSEE CALLING PORT | UEPT2 NA |
| | | 2-WIRE VOICE UNBUNDLED 1-WAY OUTGOING PBX TENNESSEE CALLING PORT | UEPTO NA |
| | | 2-WIRE VOICE UNBUNDLED 2-WAY COMBINATION PBX USAGE PORT | UEPXA \$36.47 |
| | | 2-WIRE VOICE UNBUNDLED PBX TOLL TERMINAL HOTEL PORTS | UEPXB \$36.47 |
| | | 2-WIRE VOICE UNBUNDLED PBX LD DDD TERMINALS PORT | UEPXC \$36.47 |
| | | 2-WIRE VOICE UNBUNDLED PBX LD TERMINAL SWITCHBOARD PORT | UEPXD \$36.47 |
| | | 2-WIRE VOICE UNBUNDLED PBX LD TERMINAL SWITCHBOARD IDD CAPABLE PORT | UEPXE \$36.47 |
| | | 2-WIRE VOICE UNBUNDLED 2-WAY PBX KENTUCKY ROOM AREA CALLING PORT WITHOUT LUD | UEPXF \$36.47 |
| | | 2-WIRE VOICE UNBUNDLED PBX KENTUCKY LUD AREA CALLING PORT | UEPXG \$36.47 |
| | | 2-WIRE VOICE UNBUNDLED PBX KENTUCKY PREMIUM CALLING PORT | UEPXH \$36.47 |
| | | 2-WIRE VOICE UNBUNDLED 2-WAY KENTUCKY AREA CALLING PORT WITHOUT LUD | UEPXJ \$36.47 |
| | | 2-WIRE VOICE UNBUNDLED 2-WAY PBX LOUISIANA LOCAL OPTIONAL CALLING PORT | UEPXK NA |
| | | 2-WIRE VOICE UNBUNDLED 2-WAY PBX HOTEL/HOSPITAL ECONOMY ADMINISTRATIVE CALLING PORT | UEPXL \$36.47 |
| | | 2-WIRE VOICE UNBUNDLED 2-WAY PBX HOTEL/HOSPITAL ECONOMY ROOM CALLING PORT | UEPXM \$36.47 |
| | | 2-WIRE VOICE UNBUNDLED 1-WAY OUTGOING PBX HOTEL/HOSPITAL ECONOMY ADMINIATRATIVE CALLING PORTTENNESSEE CALLING PORT | UEPXN NA |
| | | 2-WIRE VOICE UNBUNDLED 1-WAY OUTGOING PBX HOTEL/HOSPITAL DIACOUNT ROOM CALLING PORT | UEPXO \$36.47 |
| | | 2-WIRE VOICE UNBUNDLED 1-WAY OUTGOING PBX LOUISIANA LOCAL DISCOUNT CALLING PORT | UEPXP NA |
| | | 2-WIRE VOICE UNBUNDLED 2-WAY PBX MISSISSIPPI LOCAL ECONOMY CALLING PORT | UEPXQ NA |

BELLSOUTH/ADELPHIA RATES
NETWORK ELEMENTS
AND OTHER SERVICES

| DESCRIPTION | | | KY |
|-------------|--|-------|---------|
| | 2-WIRE VOICE UNBUNDLED 2-WAY PBX MISSISSIPPI LOCAL OPTIONAL CALLING PORT | UEPXR | NA |
| | 2-WIRE VOICE UNBUNDLED 1-WAY OUTGOING PBXMEASURED PORT | UEPXS | \$36.47 |
| | 2-WIRE VOICE UNBUNDLED 2-WAY PBX SOUTH CAROLINA AREA PLUS CALLING PORT | UEPXT | NA |
| | 2-WIRE VOICE UNBUNDLED PBX COLLIERVILLE & MEMPHIS CALLING PORT | UEPXU | NA |
| | 2-WIRE VOICE UNBUNDLED 2-WAY PBX TENNESSEE REGIONSERV CALLING PORT | UEPXV | NA |
| | Subsequent Activity | USASC | \$10.00 |
| | NRC - Add'l | | |
| | 2 WIRE VOICE UNBUNDLED COMBINATION 2-WAY PBX TRUNK - Residence | UEPRD | \$36.47 |
| | LINE SIDE UNBUNDLED COMBINATION 2-WAY PBX TRUNK - BUSINESS | UEPPC | \$36.47 |
| | LINE SIDE UNBUNDLED OUTWARD PBX TRUNK - BUSINESS | UEPPO | \$36.47 |
| | LINE SIDE UNBUNDLED INCOMING PBX TRUNK - BUSINESS | UEPP1 | \$36.47 |
| | LONG DISTANCE TERMINAL PBX TRUNK-BUSINESS | UEPLD | \$36.47 |
| | TN 2-WAY CALLING PLAN PBX TRUNK - BUSINESS | UEPT2 | \$36.47 |
| | TN OUTWARD CALLING PLAN PBX TRUNK - BUSINESS | UEPTO | \$36.47 |
| | 2-WIRE VOICE UNBUNDLED 2-WAY COMBINATION PBX ALABAMA CALLING PORT | UEPA2 | NA |
| | 2-WIRE VOICE UNBUNDLED 2-WAY COMBINATION PBX LOUISIANA CALLING PORT | UEPL2 | NA |
| | 2-WIRE VOICE UNBUNDLED PBX LD TERMINAL PORTS | UEPLD | \$36.47 |
| | 2-WIRE VOICE UNBUNDLED 2-WAY COMBINATION PBX TENNESSEE CALLING PORT | UEPT2 | NA |
| | 2-WIRE VOICE UNBUNDLED 1-WAY OUTGOING PBX TENNESSEE CALLING PORT | UEPTO | NA |
| | 2-WIRE VOICE UNBUNDLED 2-WAY COMBINATION PBX USAGE PORT | UEPXA | \$36.47 |
| | 2-WIRE VOICE UNBUNDLED PBX TOLL TERMINAL HOTEL PORTS | UEPXB | \$36.47 |
| | 2-WIRE VOICE UNBUNDLED PBX LD DDD TERMINALS PORT | UEPXC | \$36.47 |
| | 2-WIRE VOICE UNBUNDLED PBX LD TERMINAL SWITCHBOARD PORT | UEPXD | \$36.47 |
| | 2-WIRE VOICE UNBUNDLED PBX LD TERMINAL SWITCHBOARD IDD CAPABLE PORT | UEPXE | \$36.47 |
| | 2-WIRE VOICE UNBUNDLED 2-WAY PBX KENTUCKY ROOM AREA CALLING PORT WITHOUT LUD | UEPXF | \$36.47 |
| | 2-WIRE VOICE UNBUNDLED PBX KENTUCKY LUD AREA CALLING PORT | UEPXG | \$37.47 |
| | 2-WIRE VOICE UNBUNDLED PBX KENTUCKY PREMIUM CALLING PORT | UEPXH | \$38.47 |
| | 2-WIRE VOICE UNBUNDLED 2-WAY KENTUCKY AREA CALLING PORT WITHOUT LUD | UEPXJ | \$39.47 |
| | 2-WIRE VOICE UNBUNDLED 2-WAY PBX LOUISIANA LOCAL OPTIONAL CALLING PORT | UEPXK | NA |
| | 2-WIRE VOICE UNBUNDLED 2-WAY PBX HOTEL/HOSPITAL ECONOMY ADMINISTRATIVE CALLING PORT | UEPXL | \$36.47 |
| | 2-WIRE VOICE UNBUNDLED 2-WAY PBX HOTEL/HOSPITAL ECONOMY ROOM CALLING PORT | UEPXM | \$36.47 |
| | 2-WIRE VOICE UNBUNDLED 1-WAY OUTGOING PBX HOTEL/HOSPITAL ECONOMY ADMINIATRATIVE CALLING PORTTENNESSEE CALLING PORT | UEPXN | NA |

BELLSOUTH/ADELPHIA RATES
NETWORK ELEMENTS
AND OTHER SERVICES

| DESCRIPTION | | | KY |
|-------------|---|-------|---------|
| | 2-WIRE VOICE UNBUNDLED 1-WAY OUTGOING PBX HOTEL/HOSPITAL DISCOUNT ROOM CALLING PORT | UEPXO | \$36.47 |
| | 2-WIRE VOICE UNBUNDLED 1-WAY OUTGOING PBX LOUISIANA LOCAL DISCOUNT CALLING PORT | UEPXP | NA |
| | 2-WIRE VOICE UNBUNDLED 2-WAY PBX MISSISSIPPI LOCAL ECONOMY CALLING PORT | UEPXQ | NA |
| | 2-WIRE VOICE UNBUNDLED 2-WAY PBX MISSISSIPPI LOCAL OPTIONAL CALLING PORT | UEPXR | NA |
| | 2-WIRE VOICE UNBUNDLED 1-WAY OUTGOING PBXMEASURED PORT | UEPXS | \$36.47 |
| | 2-WIRE VOICE UNBUNDLED 2-WAY PBX SOUTH CAROLINA AREA PLUS CALLING PORT | UEPXT | NA |
| | 2-WIRE VOICE UNBUNDLED PBX COLLIERVILLE & MEMPHIS CALLING PORT | UEPXU | NA |
| | 2-WIRE VOICE UNBUNDLED 2-WAY PBX TENNESSEE REGIONSERV CALLING PORT | UEPXV | NA |
| | | | |
| | NRC - Disconnect Charge - 1st | | |
| | 2 WIRE VOICE UNBUNDLED COMBINATION 2-WAY PBX TRUNK - Residence | | NA |
| | LINE SIDE UNBUNDLED COMBINATION 2-WAY PBX TRUNK - BUSINESS | | NA |
| | LINE SIDE UNBUNDLED OUTWARD PBX TRUNK - BUSINESS | | NA |
| | LINE SIDE UNBUNDLED INCOMING PBX TRUNK - BUSINESS | | NA |
| | LONG DISTANCE TERMINAL PBX TRUNK-BUSINESS | | NA |
| | TN 2-WAY CALLING PLAN PBX TRUNK - BUSINESS | | NA |
| | TN OUTWARD CALLING PLAN PBX TRUNK - BUSINESS | | NA |
| | 2-WIRE VOICE UNBUNDLED 2-WAY COMBINATION PBX ALABAMA CALLING PORT | | NA |
| | 2-WIRE VOICE UNBUNDLED 2-WAY COMBINATION PBX LOUISIANA CALLING PORT | | NA |
| | 2-WIRE VOICE UNBUNDLED PBX LD TERMINAL PORTS | | NA |
| | 2-WIRE VOICE UNBUNDLED 2-WAY COMBINATION PBX TENNESSEE CALLING PORT | | NA |
| | 2-WIRE VOICE UNBUNDLED 1-WAY OUTGOING PBX TENNESSEE CALLING PORT | | NA |
| | 2-WIRE VOICE UNBUNDLED 2-WAY COMBINATION PBX USAGE PORT | | NA |
| | 2-WIRE VOICE UNBUNDLED PBX TOLL TERMINAL HOTEL PORTS | | NA |
| | 2-WIRE VOICE UNBUNDLED PBX LD DDD TERMINALS PORT | | NA |
| | | | |
| | 2-WIRE VOICE UNBUNDLED PBX LD TERMINAL SWITCHBOARD PORT | | NA |
| | 2-WIRE VOICE UNBUNDLED PBX LD TERMINAL SWITCHBOARD IDD CAPABLE PORT | | NA |
| | 2-WIRE VOICE UNBUNDLED 2-WAY PBX KENTUCKY ROOM AREA CALLING PORT WITHOUT LUD | | NA |
| | 2-WIRE VOICE UNBUNDLED PBX KENTUCKY LUD AREA CALLING PORT | | NA |
| | | | |
| | 2-WIRE VOICE UNBUNDLED PBX KENTUCKY PREMIUM CALLING PORT | | NA |
| | 2-WIRE VOICE UNBUNDLED 2-WAY KENTUCKY AREA CALLING PORT WITHOUT LUD | | NA |
| | 2-WIRE VOICE UNBUNDLED 2-WAY PBX LOUISIANA LOCAL OPTIONAL CALLING PORT | | NA |
| | 2-WIRE VOICE UNBUNDLED 2-WAY PBX HOTEL/HOSPITAL ECONOMY ADMINISTRATIVE CALLING PORT | | NA |
| | 2-WIRE VOICE UNBUNDLED 2-WAY PBX HOTEL/HOSPITAL ECONOMY ROOM CALLING PORT | | NA |

BELLSOUTH/ADELPHIA RATES
 NETWORK ELEMENTS
 AND OTHER SERVICES

| DESCRIPTION | | KY |
|-------------|--|----|
| | 2-WIRE VOICE UNBUNDLED 1-WAY OUTGOING PBX HOTEL/HOSPITAL ECONOMY ADMINIATRATIVE CALLING PORTTENNESSEE CALLING PORT | NA |
| | 2-WIRE VOICE UNBUNDLED 1-WAY OUTGOING PBX HOTEL/HOSPITAL DIACOUNT ROOM CALLING PORT | NA |
| | 2-WIRE VOICE UNBUNDLED 1-WAY OUTGOING PBX LOUISIANA LOCAL DISCOUNT CALLING PORT | NA |
| | 2-WIRE VOICE UNBUNDLED 2-WAY PBX MISSISSIPPI LOCAL ECONOMY CALLING PORT | NA |
| | 2-WIRE VOICE UNBUNDLED 2-WAY PBX MISSISSIPPI LOCAL OPTIONAL CALLING PORT | NA |
| | 2-WIRE VOICE UNBUNDLED 1-WAY OUTGOING PBXMEASURED PORT | NA |
| | 2-WIRE VOICE UNBUNDLED 2-WAY PBX SOUTH CAROLINA AREA PLUS CALLING PORT | NA |
| | 2-WIRE VOICE UNBUNDLED PBX COLLIERVILLE & MEMPHIS CALLING PORT | NA |
| | 2-WIRE VOICE UNBUNDLED 2-WAY PBX TENNESSEE REGIONSERV CALLING PORT | NA |
| | | |
| | NRC - Disconnect Charge - Add'l | |
| | 2 WIRE VOICE UNBUNDLED COMBINATION 2-WAY PBX TRUNK - Residence | NA |
| | LINE SIDE UNBUNDLED COMBINATION 2-WAY PBX TRUNK - BUSINESS | NA |
| | LINE SIDE UNBUNDLED OUTWARD PBX TRUNK - BUSINESS | NA |
| | LINE SIDE UNBUNDLED INCOMING PBX TRUNK - BUSINESS | NA |
| | LONG DISTANCE TERMINAL PBX TRUNK-BUSINESS | NA |
| | TN 2-WAY CALLING PLAN PBX TRUNK - BUSINESS | NA |
| | TN OUTWARD CALLING PLAN PBX TRUNK - BUSINESS | NA |
| | 2-WIRE VOICE UNBUNDLED 2-WAY COMBINATION PBX ALABAMA CALLING PORT | NA |
| | 2-WIRE VOICE UNBUNDLED 2-WAY COMBINATION PBX LOUISIANA CALLING PORT | NA |
| | 2-WIRE VOICE UNBUNDLED PBX LD TERMINAL PORTS | NA |
| | 2-WIRE VOICE UNBUNDLED 2-WAY COMBINATION PBX TENNESSEE CALLING PORT | NA |
| | 2-WIRE VOICE UNBUNDLED 1-WAY OUTGOING PBX TENNESSEE CALLING PORT | NA |
| | 2-WIRE VOICE UNBUNDLED 2-WAY COMBINATION PBX USAGE PORT | NA |
| | 2-WIRE VOICE UNBUNDLED PBX TOLL TERMINAL HOTEL PORTS | NA |
| | 2-WIRE VOICE UNBUNDLED PBX LD DDD TERMINALS PORT | NA |
| | | |
| | 2-WIRE VOICE UNBUNDLED PBX LD TERMINAL SWITCHBOARD PORT | NA |
| | 2-WIRE VOICE UNBUNDLED PBX LD TERMINAL SWITCHBOARD IDD CAPABLE PORT | NA |
| | 2-WIRE VOICE UNBUNDLED 2-WAY PBX KENTUCKY ROOM AREA CALLING PORT WITHOUT LUD | NA |
| | 2-WIRE VOICE UNBUNDLED PBX KENTUCKY LUD AREA CALLING PORT | NA |
| | | |
| | 2-WIRE VOICE UNBUNDLED PBX KENTUCKY PREMIUM CALLING PORT | NA |
| | 2-WIRE VOICE UNBUNDLED 2-WAY KENTUCKY AREA CALLING PORT WITHOUT LUD | NA |
| | 2-WIRE VOICE UNBUNDLED 2-WAY PBX LOUISIANA LOCAL OPTIONAL CALLING PORT | NA |

BELLSOUTH/ADELPHIA RATES
NETWORK ELEMENTS
AND OTHER SERVICES

| DESCRIPTION | | | KY |
|-------------|--|--|--------------|
| | | 2-WIRE VOICE UNBUNDLED 2-WAY PBX HOTEL/HOSPITAL ECONOMY ADMINISTRATIVE CALLING PORT | NA |
| | | 2-WIRE VOICE UNBUNDLED 2-WAY PBX HOTEL/HOSPITAL ECONOMY ROOM CALLING PORT | NA |
| | | 2-WIRE VOICE UNBUNDLED 1-WAY OUTGOING PBX HOTEL/HOSPITAL ECONOMY ADMINIATRATIVE CALLING PORTTENNESSEE CALLING PORT | NA |
| | | 2-WIRE VOICE UNBUNDLED 1-WAY OUTGOING PBX HOTEL/HOSPITAL DIACOUNT ROOM CALLING PORT | NA |
| | | 2-WIRE VOICE UNBUNDLED 1-WAY OUTGOING PBX LOUISIANA LOCAL DISCOUNT CALLING PORT | NA |
| | | 2-WIRE VOICE UNBUNDLED 2-WAY PBX MISSISSIPPI LOCAL ECONOMY CALLING PORT | NA |
| | | 2-WIRE VOICE UNBUNDLED 2-WAY PBX MISSISSIPPI LOCAL OPTIONAL CALLING PORT | NA |
| | | 2-WIRE VOICE UNBUNDLED 1-WAY OUTGOING PBXMEASURED PORT | NA |
| | | 2-WIRE VOICE UNBUNDLED 2-WAY PBX SOUTH CAROLINA AREA PLUS CALLING PORT | NA |
| | | 2-WIRE VOICE UNBUNDLED PBX COLLIERVILLE & MEMPHIS CALLING PORT | NA |
| | | 2-WIRE VOICE UNBUNDLED 2-WAY PBX TENNESSEE REGIONSERV CALLING PORT | NA |
| | | | |
| | | NRC - OSS LSR Charge, Electronic, per LSR received from the CLEC by one of the OSS interactive interfaces | SOMEK \$3.50 |
| | | NRC - Incremental Charge - Manual Service Order - 1st | SOMAN NA |
| | | NRC - Incremental Charge - Manual Service Order - Add'l | SOMAN NA |
| | | NRC - Incremental Charge - Manual Service Order - Disconnect - 1st | SOMAN NA |
| | | NRC - Incremental Charge - Manual Service Order - Disconnect - Add'l | SOMAN NA |
| | | | |
| | | 2-Wire Analog Hunting, per line per month | HTGUX \$0.29 |
| | | NRC - 1st | HTGUX \$2.14 |
| | | NRC - Add'l | HTGUX \$2.14 |
| | | Coin Port, per month | \$3.04 |
| | | NRC - 1st | \$40.71 |
| | | NRC - Add'l | \$40.71 |
| | | NRC - Disconnect Charge - 1st | NA |
| | | NRC - Disconnect Charge - Add'l | NA |
| | | NRC - Incremental Charge - Manual Service Order - 1st | SOMAN NA |
| | | NRC - Incremental Charge - Manual Service Order - Add'l | SOMAN NA |
| | | NRC - Incremental Charge - Manual Service Order - Disconnect - 1st | SOMAN NA |
| | | NRC - Incremental Charge - Manual Service Order - Disconnect - Add'l | SOMAN NA |
| | | | |
| | | 4- Wire Coin Port, per month | NA |
| | | NRC - 1st | NA |
| | | NRC - Add'l | NA |
| | | NRC - Disconnect Charge - 1st | NA |
| | | NRC - Disconnect Charge - Add'l | NA |
| | | NRC - Incremental Charge - Manual Service Order - 1st | NA |
| | | NRC - Incremental Charge - Manual Service Order - Add'l | NA |
| | | NRC - Incremental Charge - Manual Service Order - Disconnect - 1st | NA |
| | | NRC - Incremental Charge - Manual Service Order - Disconnect - Add'l | NA |

BELLSOUTH/ADELPHIA RATES
 NETWORK ELEMENTS
 AND OTHER SERVICES

| DESCRIPTION | | KY |
|--|-----|-----------------|
| VERTICAL FEATURES | | |
| Local Switching Features offered with Port, Per month | N/A | No add'l charge |
| Three-Way Calling, per month | | NA |
| NRC | | NA |
| NRC - Disconnect | | NA |
| Customer Changeable Speed Calling, per month | | NA |
| NRC | | NA |
| NRC - Disconnect | | NA |
| Call Waiting | | NA |
| NRC | | NA |
| NRC - Disconnect | | NA |
| Remote Activation of Call Forwarding, per month | | NA |
| NRC | | NA |
| NRC - Disconnect | | NA |
| Cancel Call Waiting, per month | | NA |
| NRC | | NA |
| NRC - Disconnect | | NA |
| Automatic Callback, per month | | NA |
| NRC | | NA |
| NRC - Disconnect | | NA |
| Automatic Recall, per month | | NA |
| NRC | | NA |
| NRC - Disconnect | | NA |
| Calling Number Delivery, per month | | NA |
| NRC | | NA |
| NRC - Disconnect | | NA |
| Calling Number Delivery Blocking, per month | | NA |
| NRC | | NA |
| NRC - Disconnect | | NA |
| Customer Originated Trace, per month | | NA |
| NRC | | NA |
| NRC - Disconnect | | NA |
| Selective Call Rejection, per month | | NA |
| NRC | | NA |
| NRC - Disconnect | | NA |
| Selective Call Forwarding, per month | | NA |
| NRC | | NA |
| NRC - Disconnect | | NA |
| Selective Call Acceptance, per month | | NA |
| NRC | | NA |
| NRC - Disconnect | | NA |
| Multiline Hunt Service (Rotary) | | |
| Service per line, (in addition to port) , per month | | NA |
| NRC | | NA |
| NRC - Disconnect | | NA |
| Call Forwarding Variable, per month | | NA |
| NRC | | NA |
| NRC - Disconnect | | NA |
| Call Forwarding Busy Line, per month | | NA |
| NRC | | NA |
| NRC - Disconnect | | NA |
| Call Forwarding Don't Answer All Calls, per month | | NA |
| NRC | | NA |

BELLSOUTH/ADELPHIA RATES
NETWORK ELEMENTS
AND OTHER SERVICES

| DESCRIPTION | | KY |
|---|-------|-----|
| NRC - Disconnect | | NA |
| Remote Call Forwarding, per month | | NA |
| NRC | | NA |
| NRC - Disconnect | | NA |
| Call Transfer, per month | | NA |
| NRC | | NA |
| NRC - Disconnect | | NA |
| Call Hold, per month | | NA |
| NRC | | NA |
| NRC - Disconnect | | NA |
| Toll Restricted Service, per month | | NA |
| NRC | | NA |
| NRC - Disconnect | | NA |
| Message Waiting Indicator - Stutter Dial Tone, per month | | NA |
| NRC | | NA |
| NRC - Disconnect | | NA |
| Anonymous Call Rejection, per month | | NA |
| NRC | | NA |
| NRC - Disconnect | | NA |
| Shared Call Appearances of a DN, per month | | NA |
| NRC | | NA |
| NRC - Disconnect | | NA |
| Multiple Call Appearances, per month | | NA |
| NRC | | NA |
| NRC - Disconnect | | NA |
| ISDN Bridged Call Exclusion, per month | | NA |
| NRC | | NA |
| NRC - Disconnect | | NA |
| Call by Call Access, per month | | NA |
| NRC | | NA |
| NRC - Disconnect | | NA |
| Privacy Release, per month | | NA |
| NRC | | NA |
| NRC - Disconnect | | NA |
| Multi Appearance Directory Number Calls, per month | | NA |
| NRC | | NA |
| NRC - Disconnect | | NA |
| Make Set Busy, per month | | NA |
| NRC | | NA |
| NRC - Disconnect | | NA |
| Teen Service (Res. Dist. Alerting Service), per month | | NA |
| NRC | | NA |
| NRC - Disconnect | | NA |
| Code Restriction and Diversion, per month | | NA |
| NRC | | NA |
| NRC - Disconnect | | NA |
| Call Park, per month | | NA |
| NRC | | NA |
| NRC - Disconnect | | NA |
| Automatic Line, per month | | NA |
| NRC | | NA |
| NRC - Disconnect | | NA |
| 2-WIRE ISDN BRI FEATURES | | |
| Shared Primary Number-First Appr On Each Add'l Terminal | DS1FJ | TBD |

BELLSOUTH/ADELPHIA RATES
NETWORK ELEMENTS
AND OTHER SERVICES

| DESCRIPTION | | KY |
|---|-------|-----|
| Secondary Only Dn (Shared/Non-Shared) First Appearance | LLDSF | TBD |
| Shared Secondary Only Dn-First Appr On Each Add'l Term | DS1F1 | TBD |
| Shared Non-ISDN DN | DOE | TBD |
| Privacy Release | DS1FU | TBD |
| Manual Exclusion | DS1FM | TBD |
| Call Forwarding Variable-Voice Or Voice/Data | LLNCV | TBD |
| Call Forwarding Variable - Data | LLOCD | TBD |
| Call Forwarding Variable - Feature Button - Voice | GJXCF | TBD |
| Call Forwarding Variable - Feature Button - Data | LLPCD | TBD |
| Call Forwarding Busy Line - Voice Or Voice/Data | LLQCV | TBD |
| Call Forwarding Busy Line - Data | LLRCD | TBD |
| Call Frwdng Busy Line-Prgmmbl-Voice Or Voice/Data | M6AVA | TBD |
| Call Forwarding Busy Line - Programmable - Data | M6ADF | TBD |
| Call Forwarding Don't Answer - Voice Or Voice/Data | LLSCV | TBD |
| Call Forwarding Don't Answer - Data | LLUCD | TBD |
| Call Frwdng Don't Answer-Prgmmble Voice Or Voice/Data | M6BVA | TBD |
| Call Forwarding Don't Answer - Programmable - Data | M6BDF | TBD |
| Call Frwdng Multiple Simultaneous - Voice Or Voice/Data | M6CV5 | TBD |
| Call Forwarding Multiple Simultaneous - Data | M6CD5 | TBD |
| Conference, Drop, Hold And Transfer | DS1FN | TBD |
| Six-Way Conference, Drop, Hold And Transfer | LLY6P | TBD |
| Multi-Line Hunt Group - Voice Or Voice/Data | HTG | TBD |
| Multi-Line Hunt Group - Data | HTGSD | TBD |
| Speed Calling | LLZSU | TBD |
| Visual Message Waiting Indicator | LLAVP | TBD |
| Audible Message Waiting Indicator | MWW | TBD |
| Additional Call Appearance, PDN Or DN | DS1FG | TBD |
| Call Tracing | NST | TBD |
| Call Return | NSS | TBD |
| Preferred Call Forwarding | NCE | TBD |
| Call Block | NSY | TBD |
| Repeat Dialing | NSQ | TBD |
| Per Line Blocking For Agencies/Law Enforcement | NOB | TBD |
| Per Line Blocking For Non-Pub Customers | NOBNN | TBD |
| Per Line Blocking For General Public | NOBPC | TBD |
| Per Line Blocking For Non-Pub, And Non-Listed Customer | NOBPP | TBD |
| Per Line Blocking For Non-Pub Customers | NOBNP | TBD |
| Per Line Blocking For Non-Pub Customers | NOBNR | TBD |
| Call Return Denial Of, Per Activation | BCR | TBD |
| Repeat Dialing, Denial Of, Per Activation | BRD | TBD |
| Automatic Line/Direct Connect | M6GN9 | TBD |
| Make Set Busy | M6MPD | TBD |
| Selective Call Acceptance | M6K16 | TBD |
| Call Park/Call Retrieve | M6HP6 | TBD |
| Call Transfer System Exception | M6QTD | TBD |
| Make Set Busy - Intragroup | M6MGD | TBD |
| All Customized Code Restrictions | CREX+ | TBD |
| Additional Listings | CLT | TBD |
| Additional Listing No Rate | FLT | TBD |
| Cross Reference Listing | LLT | TBD |
| Non-Pub Listing No Rate | NP3 | TBD |
| Non-List Listing | NLT | TBD |
| Non-List Listing No Rate | NLE | TBD |
| Alternate Call Listing | FNA | TBD |
| Manual Service Order Charge | SOMAN | TBD |
| All Selective Class Of Call Screening | SRG++ | TBD |

BELLSOUTH/ADELPHIA RATES
 NETWORK ELEMENTS
 AND OTHER SERVICES

| DESCRIPTION | | | KY |
|-------------|---|--|----------------|
| | | ISDN Message Waiting Indication-Lamp, per month | NA |
| | | NRC | NA |
| | | NRC - Disconnect | NA |
| | | ISDN Feature Function Buttons | NA |
| | | NRC | NA |
| | | NRC - Disconnect | NA |
| | | Subsequent Ordering Charge – (per order, per line) | NA |
| | | NRC - Electronic - 1st | NA |
| | | NRC - Electronic - Add'l | NA |
| | | NRC - Manual - 1st | NA |
| | | NRC - Manual - Add'l | NA |
| | | NRC - Disconnect | NA |
| | | | |
| | | Unbundled Port Usage Charges | |
| | | End Office Switching (Port Usage) | |
| | | End Office Switching Function, per mou | N/A \$0.002562 |
| | | End Office Switching Function, add'l mou (5) | N/A NA |
| | | End Office Interoffice Trunk Port—Shared, per mou | N/A NA |
| | | | |
| | | Tandem Switching (Port Usage) (Local or Access Tandem) | |
| | | Tandem Switching Function per mou | N/A \$0.001096 |
| | | Tandem Interoffice Trunk Port - Shared per mou | NA |
| | | | |
| | | Common (Shared) Transport | |
| | | Common (Shared) Transport per mile per mou | N/A \$0.000049 |
| | | Common (Shared) Transport Facilities Termination per mou | N/A \$0.000426 |
| | | | |
| | | NOTES: | |
| | 1 | Port rate includes all available features. | |
| | 2 | Transmission/usage charges associated with POTS circuit switched usage will also apply to circuit switched voice and/or circuit switched data transmission by B-Channels associated with 2-wire ISDN ports. | |
| | 3 | Access to B Channel or D Channel Packet capabilities will be available only through BFR/New Business Request Process. Rates for the packet capabilities will be determined via the Bona Fide Request/New Business Request Process. | |
| | 4 | This rate element is for those states which have a specific rate for User Profile per B Channel. | |
| | 5 | This rate element is for use in those states with a different rate for additional minutes of use. | |

BELLSOUTH/ADELPHIA RATES
NETWORK ELEMENTS
AND OTHER SERVICES

| UNBUNDLED DEDICATED TRANSPORT - Local Channel | | | KY |
|---|--------|--|----------|
| Local Channel - Dedicated - 2-Wire VG | | | |
| Monthly Recurring per month | ULDV2 | | \$22.26 |
| NRC - 2-wire VG - 1st | ULDV2 | | \$585.15 |
| NRC - 2-wire VG -Add'l | ULDV2 | | \$98.53 |
| NRC - 2-Wire VG - Disconnect Chg - 1st | ULDV2 | | NA |
| NRC - 2-Wire VG - Disconnect Chg - Add'l | ULDV2 | | NA |
| NRC - Manual Svc Order, per LSR | SOMAN | | \$19.99 |
| NRC - Manual Svc Order, per LSR disconnect | SOMAN | | NA |
| NRC - Electronic Svc Order, per LSR | SOMECE | | \$3.50 |
| NRC - Electronic Svc Order, per LSR disconnect | SOMECE | | NA |
| NRC - 2-Wire VG - Incremental Charge--Manual Svc Order - 1st | SOMAN | | \$41.46 |
| NRC - 2-Wire VG - Incremental Charge--Manual Svc Order - Add'l | SOMAN | | \$11.99 |
| NRC - 2-Wire VG - Incremental Charge--Manual Svc Order-Disconnect | SOMAN | | NA |
| Local Channel - Dedicated - 4-Wire VG | | | |
| Monthly Recurring per month | ULDV4 | | \$23.38 |
| NRC - 4-Wire VG - 1st | ULDV4 | | \$585.15 |
| NRC - 4-Wire VG - Add'l | ULDV4 | | \$98.53 |
| NRC - 4-Wire VG - Disconnect Chg - 1st | ULDV4 | | NA |
| NRC - 4-Wire VG - Disconnect Chg - Add'l | ULDV4 | | NA |
| NRC - Manual Svc Order, per LSR | SOMAN | | \$19.99 |
| NRC - Manual Svc Order, per LSR disconnect | SOMAN | | NA |
| NRC - Electronic Svc Order, per LSR | SOMECE | | \$3.50 |
| NRC - Electronic Svc Order, per LSR disconnect | SOMECE | | NA |
| NRC - 4-Wire VG - Incremental Charge--Manual Svc Order - 1st | SOMAN | | \$41.46 |
| NRC - 4-Wire VG - Incremental Charge--Manual Svc Order - Add'l | SOMAN | | \$11.99 |
| NRC - 4-Wire VG - Incremental Charge--Manual Svc Order-Disconnect | SOMAN | | NA |
| Local Channel - Dedicated - DS1 | | | |
| DS1 per month | ULDF1 | | \$43.80 |
| NRC - DS1 - 1st | ULDF1 | | \$538.95 |
| NRC - DS1 - Add'l | ULDF1 | | \$464.94 |
| NRC - DS1 - Disconnect Chg - 1st | ULDF1 | | NA |
| NRC - DS1 - Disconnect Chg - Add'l | ULDF1 | | NA |
| NRC - Manual Svc Order, per LSR | SOMAN | | \$19.99 |
| NRC - Manual Svc Order, per LSR disconnect | SOMAN | | NA |
| NRC - Electronic Svc Order, per LSR | SOMECE | | \$3.50 |
| NRC - Electronic Svc Order, per LSR disconnect | SOMECE | | NA |
| NRC - DS1 - Incremental Charge--Manual Svc Order - 1st | SOMAN | | \$87.71 |
| NRC - DS1 - Incremental Charge--Manual Svc Order - Add'l | SOMAN | | NA |
| NRC - DS1 - Incremental Charge--Manual Svc Order-Disconnect | SOMAN | | NA |
| Local Channel - Dedicated - DS3 | | | |
| DS3 - per mile per month | 1L5NC | | \$34.00 |
| DS3 - Facility Termination per month | ULDF3 | | \$635.09 |
| NRC - DS3 - Facility Termination - 1st | ULDF3 | | \$1,091 |
| NRC - DS3 - Facility Termination - Add'l | ULDF3 | | \$661.23 |
| NRC - DS3 - Facility Termination - Disconnect - 1st | ULDF3 | | NA |
| NRC - DS3 - Facility Termination - Disconnect - Add'l | ULDF3 | | NA |
| NRC - Manual Svc Order, per LSR | SOMAN | | \$19.99 |
| NRC - Manual Svc Order, per LSR disconnect | SOMAN | | NA |
| NRC - Electronic Svc Order, per LSR | SOMECE | | \$3.50 |
| NRC - Electronic Svc Order, per LSR disconnect | SOMECE | | NA |
| NRC - DS3 -Incremental Charge--Manual Svc Order - 1st | SOMAN | | \$93.12 |
| NRC - DS3 - Incremental Charge--Manual Svc Order - Add'l | SOMAN | | \$93.12 |
| NRC - DS3 - Incremental Charge--Manual Svc Order-Disconnect -1st | SOMAN | | NA |

BELLSOUTH/ADELPHIA RATES
NETWORK ELEMENTS
AND OTHER SERVICES

| UNBUNDLED DEDICATED TRANSPORT - Local Channel | | | KY |
|---|---|-------|----------|
| | NRC - DS3 - Incremental Charge--Manual Svc Order-Disconnect-Add'l | SOMAN | NA |
| Local Channel - Dedicated - STS-1 | | | |
| | STS-1 - per mile per month | 1L5NC | \$34.00 |
| | STS-1 - Facility Termination per month | ULDFS | \$635.09 |
| | NRC - STS-1 - Facility Termination - 1st | ULDFS | \$1,091 |
| | NRC - STS-1 - Facility Termination - Add'l | ULDFS | \$661.23 |
| | NRC - STS-1 - Facility Termination - Disconnect - 1st | ULDFS | NA |
| | NRC - STS-1 - Facility Termination - Disconnect - Add'l | ULDFS | NA |
| | NRC - Manual Svc Order, per LSR | SOMAN | \$19.99 |
| | NRC - Manual Svc Order, per LSR disconnect | SOMAN | NA |
| | NRC - Electronic Svc Order, per LSR | SOMEK | \$3.50 |
| | NRC - Electronic Svc Order, per LSR disconnect | SOMEK | NA |
| | NRC - STS-1 -Incremental Charge--Manual Svc Order - 1st | SOMAN | \$93.12 |
| | NRC - STS-1 - Incremental Charge--Manual Svc Order - Add'l | SOMAN | \$93.12 |
| | NRC - STS-1 - Incremental Charge--Manual Svc Order-Disconnect -1st | SOMAN | NA |
| | NRC - STS-1 - Incremental Charge--Manual Svc Order-Disconnect-Add'l | SOMAN | NA |
| Local Channel - Dedicated - OC3 | | | |
| | OC3 per mile per month | TBD | \$28.56 |
| | OC3 Facility Termination per month | TBD | \$1,493 |
| | NRC - OC3 - Facility Termination - 1st | TBD | \$1,543 |
| | NRC - OC3 - Facility Termination - Add'l | TBD | \$661.23 |
| | NRC - OC3 - Facility Termination - Disconnect Chg - 1st | TBD | NA |
| | NRC - OC3 - Facility Termination - Disconnect Chg - Add'l | TBD | NA |
| | NRC - Manual Svc Order, per LSR | SOMAN | \$19.99 |
| | NRC - Manual Svc Order, per LSR disconnect | SOMAN | NA |
| | NRC - Electronic Svc Order, per LSR | SOMEK | \$3.50 |
| | NRC - Electronic Svc Order, per LSR disconnect | SOMEK | NA |
| | NRC - OC3 - Incremental Charge--Manual Svc Order - 1st | SOMAN | \$93.12 |
| | NRC - OC3 - Incremental Charge--Manual Svc Order - Add'l | SOMAN | \$93.12 |
| | NRC - OC3 - Incremental Charge--Manual Svc Order-Disconnect-1st | SOMAN | NA |
| | NRC - OC3 - Incremental Charge--Manual Svc Order-Disconnect-Add'l | SOMAN | NA |
| Local Channel - Dedicated - OC12 | | | |
| | OC12 per mile per month | TBD | \$40.80 |
| | OC12 Facility Termination per month | TBD | \$4,492 |
| | NRC - OC12 - Facility Termination - 1st | TBD | \$1,858 |
| | NRC - OC12 - Facility Termination - Add'l | TBD | \$661.23 |
| | NRC - OC12 - Facility Termination -Disconnect Chg - 1st | TBD | NA |
| | NRC - OC12 - Facility Termination - Disconnect Chg - Add'l | TBD | NA |
| | NRC - Manual Svc Order, per LSR | SOMAN | \$19.99 |
| | NRC - Manual Svc Order, per LSR disconnect | SOMAN | NA |
| | NRC - Electronic Svc Order, per LSR | SOMEK | \$3.50 |
| | NRC - Electronic Svc Order, per LSR disconnect | SOMEK | NA |
| | NRC - OC12 - Incremental Charge--Manual Svc Order - 1st | SOMAN | \$93.12 |
| | NRC - OC12 - Incremental Charge--Manual Svc Order - Add'l | SOMAN | \$93.12 |
| | NRC - OC12 - Incremental Charge--Manual Svc Order-Disconnect-1st | SOMAN | NA |
| | NRC - OC12 - Incremental Charge--Manual Svc Order-Disconnect-Add'l | SOMAN | NA |
| Local Channel - Dedicated - OC48 | | | |
| | OC48 per mile per month | TBD | \$133.84 |
| | OC48 Facility Termination per month | TBD | \$2,156 |
| | OC48 - Interface OC12 on OC48 per month | TBD | \$728.81 |
| | NRC - OC48 - Facility Termination - 1st | TBD | \$1,858 |
| | NRC - OC48 - Facility Termination -Add'l | TBD | \$661.23 |

BELLSOUTH/ADELPHIA RATES
NETWORK ELEMENTS
AND OTHER SERVICES

| UNBUNDLED DEDICATED TRANSPORT - Local Channel | | | KY |
|--|--|-------|-------------|
| | NRC - OC48 - Interface OC12 on OC48 - 1st | TBD | \$844.21 |
| | NRC -OC48 - Interface OC12 on OC48 -Add'l | TBD | \$516.89 |
| | NRC - OC48 - Facility Termination - Disconnect Chg - 1st | TBD | NA |
| | NRC - OC48 - Facility Termination - Disconnect Chg - Add'l | TBD | NA |
| | NRC - OC48 - Interface OC12 on OC48 - Disconnect Chg - 1st | TBD | NA |
| | NRC - OC48 - Interface OC12 on OC48 - Disconnect Chg - Add'l | TBD | NA |
| | NRC - Manual Svc Order, per LSR | SOMAN | \$19.99 |
| | NRC - Manual Svc Order, per LSR disconnect | SOMAN | NA |
| | NRC - Electronic Svc Order, per LSR | SOMEK | \$3.50 |
| | NRC - Electronic Svc Order, per LSR disconnect | SOMEK | NA |
| | NRC - OC48 - Incremental Charge--Manual Svc Order - 1st | SOMAN | \$93.12 |
| | NRC - OC48 - Incremental Charge--Manual Svc Order - Add'l | SOMAN | \$93.12 |
| | NRC - OC48 -Interface-Incremental Cost-Manual Svc. Order vs. Electronic- | SOMAN | \$93.12 |
| | NRC - OC48 -Interface-Incremental Cost-Manual Svc. Order vs. Electronic- | SOMAN | \$93.12 |
| | NRC - OC48 - Incremental Charge--Manual Svc Order-Disconnect-1st | SOMAN | NA |
| | NRC - OC48 - Incremental Charge--Manual Svc Order-Disconnect-Add'l | SOMAN | NA |
| | NRC - OC48 -Interface-Incremental Cost-Manual Svc. Order vs. Electronic- | SOMAN | NA |
| | NRC - OC48 -Interface-Incremental Cost-Manual Svc. Order vs. Electronic- | SOMAN | NA |
| UNBUNDLED DEDICATED TRANSPORT - Interoffice Channel | | | |
| | Interoffice Transport - Dedicated - 2-wire VG | | |
| | 2-Wire VG - per mile per month | 1L5XX | \$0.0301 |
| | 2-Wire VG - Facility Termination per month | U1TV2 | \$27.66 |
| | NRC - 2-wire VG - Facility Termination -1st | U1TV2 | \$142.31 |
| | NRC - 2-wire VG - Facility Termination - Add'l | U1TV2 | \$56.21 |
| | NRC - 2-wire VG -Facility Termination - Disconnect Charge -1st | U1TV2 | NA |
| | NRC - 2-wire VG - Facility Termination - Disconnect Charge -Add'l | U1TV2 | NA |
| | NRC - Manual Svc Order, per LSR | SOMAN | \$19.99 |
| | NRC - Manual Svc Order, per LSR disconnect | SOMAN | NA |
| | NRC - Electronic Svc Order, per LSR | SOMEK | \$3.50 |
| | NRC - Electronic Svc Order, per LSR disconnect | SOMEK | NA |
| | NRC - 2-wire VG - Incremental Charge--Manual Svc Order - 1st | SOMAN | \$37.21 |
| | NRC - 2-wire VG - Incremental Charge--Manual Svc Order - Add'l | SOMAN | \$37.21 |
| | NRC - 2-wire VG - Incremental Charge--Manual Svc Order-Disconnect--1st | SOMAN | NA |
| | NRC - 2-wire VG - Incremental Charge--Manual Svc Order-Disconnect--Add'l | SOMAN | NA |
| Common (Shared) Transport | | | |
| | Common (Shared) Transport per mile per mou | NA | \$0.0000049 |
| | Common (Shared) Transport Facilities Termination per mou | NA | \$0.000426 |
| Interoffice Transport - Dedicated - 4-wire VG | | | |
| | 4-Wire VG - per mile per month | 1L5XX | NA |
| | 4-Wire VG - Facility Termination per month | U1TV4 | NA |
| | NRC - 4-wire VG - Facility Termination -1st | U1TV4 | NA |
| | NRC - 4-wire VG - Facility Termination - Add'l | U1TV4 | NA |
| | NRC - 4-wire VG -Facility Termination - Disconnect Charge -1st | U1TV4 | NA |
| | NRC - 4-wire VG - Facility Termination - Disconnect Charge -Add'l | U1TV4 | NA |
| | NRC - Manual Svc Order, per LSR | SOMAN | NA |
| | NRC - Manual Svc Order, per LSR disconnect | SOMAN | NA |
| | NRC - Electronic Svc Order, per LSR | SOMEK | NA |
| | NRC - Electronic Svc Order, per LSR disconnect | SOMEK | NA |
| | NRC - 4-wire VG - Incremental Charge--Manual Svc Order - 1st | SOMAN | NA |
| | NRC - 4-wire VG - Incremental Charge--Manual Svc Order - Add'l | SOMAN | NA |
| | NRC - 4-wire VG - Incremental Charge--Manual Svc Order-Disconnect--1st | SOMAN | NA |
| | NRC - 4-wire VG - Incremental Charge--Manual Svc Order-Disconnect--Add'l | SOMAN | NA |

BELLSOUTH/ADELPHIA RATES
NETWORK ELEMENTS
AND OTHER SERVICES

| UNBUNDLED DEDICATED TRANSPORT - Local Channel | | | KY |
|--|-------|--|----------|
| Interoffice Transport - Dedicated - DS0 - 56 | | | |
| DS0 - per mile per month | 1L5XX | | \$0.0301 |
| DS0 - Facility Termination per month | U1TD5 | | \$26.95 |
| NRC - DS0 - Facility Termination - 1st | U1TD5 | | \$142.31 |
| NRC - DS0 - Facility Termination - Add'l | U1TD5 | | \$56.21 |
| NRC - DS0 -Facility Termination - Disconnect Charge - 1st | U1TD5 | | NA |
| NRC - DS0 - Facility Termination - Disconnect Charge - Add'l | U1TD5 | | NA |
| NRC - Manual Svc Order, per LSR | SOMAN | | \$19.99 |
| NRC - Manual Svc Order, per LSR disconnect | SOMAN | | NA |
| NRC - Electronic Svc Order, per LSR | SOMEK | | \$3.50 |
| NRC - Electronic Svc Order, per LSR disconnect | SOMEK | | NA |
| NRC - DS0 -Incremental Charge--Manual Svc Order - 1st | SOMAN | | \$37.21 |
| NRC -DS0 - Incremental Charge--Manual Svc Order - Add'l | SOMAN | | \$37.21 |
| NRC - DS0 -Incremental Charge--Manual Svc Order-Disconnect--1st | SOMAN | | NA |
| NRC - DS0 -Incremental Charge--Manual Svc Order-Disconnect--Add'l | SOMAN | | NA |
| Interoffice Transport - Dedicated -64 KBPS | | | |
| DS0 - per mile per month | 1L5XX | | \$0.0301 |
| DS0 - Facility Termination per month | U1TD6 | | \$26.95 |
| NRC - DS0 - Facility Termination - 1st | U1TD6 | | \$142.31 |
| NRC - DS0 - Facility Termination - Add'l | U1TD6 | | \$56.21 |
| NRC - DS0 -Facility Termination - Disconnect Charge - 1st | U1TD6 | | NA |
| NRC - DS0 - Facility Termination - Disconnect Charge - Add'l | U1TD6 | | NA |
| NRC - Manual Svc Order, per LSR | SOMAN | | \$19.99 |
| NRC - Manual Svc Order, per LSR disconnect | SOMAN | | NA |
| NRC - Electronic Svc Order, per LSR | SOMEK | | \$3.50 |
| NRC - Electronic Svc Order, per LSR disconnect | SOMEK | | NA |
| NRC - DS0 -Incremental Charge--Manual Svc Order - 1st | SOMAN | | \$37.21 |
| NRC -DS0 - Incremental Charge--Manual Svc Order - Add'l | SOMAN | | \$37.21 |
| NRC - DS0 -Incremental Charge--Manual Svc Order-Disconnect--1st | SOMAN | | NA |
| NRC - DS0 -Incremental Charge--Manual Svc Order-Disconnect--Add'l | SOMAN | | NA |
| Interoffice Transport - Dedicated - DS1 | | | |
| DS1 - per mile per month | 1L5XX | | \$0.4500 |
| DS1 - Facility Termination per month | U1TF1 | | \$55.05 |
| NRC - DS1-Facility Termination - 1st | U1TF1 | | \$298.18 |
| NRC - DS1 - Facility Termination - Add'l | U1TF1 | | \$231.23 |
| NRC - DS1 - Facility Termination - Disconnect Charge - 1st | U1TF1 | | NA |
| NRC - DS1 - Facility Termination -Disconnect Charge - Add'l | U1TF1 | | NA |
| NRC - Manual Svc Order, per LSR | SOMAN | | \$19.99 |
| NRC - Manual Svc Order, per LSR disconnect | SOMAN | | NA |
| NRC - Electronic Svc Order, per LSR | SOMEK | | \$3.50 |
| NRC - Electronic Svc Order, per LSR disconnect | SOMEK | | NA |
| NRC - DS1 - Incremental Charge--Manual Svc Order - 1st | SOMAN | | NA |
| NRC -DS1 - Incremental Charge--Manual Svc Order - Add'l | SOMAN | | NA |
| NRC - DS1 - Incremental Charge--Manual Svc Order-Disconnect--1st | SOMAN | | NA |
| NRC - DS1 - Incremental Charge--Manual Svc Order-Disconnect--Add'l | SOMAN | | NA |
| Interoffice Transport - Dedicated - DS3 | | | |
| DS3 - per mile per month | 1L5XX | | \$12.62 |
| DS3 -Facility Termination per month | U1TF3 | | \$1,204 |
| NRC - DS3 - Facility Termination -1st | U1TF3 | | \$946.23 |
| NRC - DS3 - Facility Termination - Add'l | U1TF3 | | \$516.89 |
| NRC - DS3 - Facility Termination - Disconnect Charge - 1st | U1TF3 | | NA |
| NRC - DS3 - Facility Termination - Disconnect Charge - Add'l | U1TF3 | | NA |
| NRC - Manual Svc Order, per LSR | SOMAN | | \$19.99 |

BELLSOUTH/ADELPHIA RATES
NETWORK ELEMENTS
AND OTHER SERVICES

| UNBUNDLED DEDICATED TRANSPORT - Local Channel | | | KY |
|--|---|-------|----------|
| | NRC - Manual Svc Order, per LSR disconnect | SOMAN | NA |
| | NRC - Electronic Svc Order, per LSR | SOMEK | \$3.50 |
| | NRC - Electronic Svc Order, per LSR disconnect | SOMEK | NA |
| | NRC - DS3 - Incremental Charge--Manual Svc Order - 1st | SOMAN | \$93.12 |
| | NRC - DS3 - Incremental Charge--Manual Svc Order - Add'l | SOMAN | \$93.12 |
| | NRC - DS3 - Incremental Charge--Manual Svc Order-Disconnect--1st | SOMAN | NA |
| | NRC - DS3 - Incremental Charge--Manual Svc Order-Disconnect--Add'l | SOMAN | NA |
| Interoffice Transport - Dedicated - STS-1 | | | |
| | STS-1 - per mile per month | 1L5XX | \$12.62 |
| | STS-1 -Facility Termination per month | U1TFS | \$1,204 |
| | NRC - STS-1 - Facility Termination -1st | U1TFS | \$946.23 |
| | NRC - STS-1 - Facility Termination - Add'l | U1TFS | \$516.89 |
| | NRC - STS-1 - Facility Termination - Disconnect Charge - 1st | U1TFS | NA |
| | NRC - STS-1 - Facility Termination - Disconnect Charge - Add'l | U1TFS | NA |
| | NRC - Manual Svc Order, per LSR | SOMAN | \$19.99 |
| | NRC - Manual Svc Order, per LSR disconnect | SOMAN | NA |
| | NRC - Electronic Svc Order, per LSR | SOMEK | \$3.50 |
| | NRC - Electronic Svc Order, per LSR disconnect | SOMEK | NA |
| | NRC - STS-1 - Incremental Charge--Manual Svc Order - 1st | SOMAN | \$93.12 |
| | NRC - STS-1 - Incremental Charge--Manual Svc Order - Add'l | SOMAN | \$93.12 |
| | NRC - DS3 - Incremental Charge--Manual Svc Order-Disconnect--1st | SOMAN | NA |
| | NRC - DS3 - Incremental Charge--Manual Svc Order-Disconnect--Add'l | SOMAN | NA |
| Interoffice Transport - Dedicated - OC3 | | | |
| | OC3 -per mile per month | 1L5XX | \$27.97 |
| | OC3 -Facility Termination per month | TBD | \$3,390 |
| | NRC - OC-3 - Facility Termination - 1st | TBD | \$1,399 |
| | NRC - OC-3 - Facility Termination - Add'l | TBD | \$516.89 |
| | NRC - OC-3 - Facility Termination - Disconnect Charge - 1st | TBD | NA |
| | NRC - OC-3 - Facility Termination - Disconnect Charge - Add'l | TBD | NA |
| | NRC - Manual Svc Order, per LSR | SOMAN | \$19.99 |
| | NRC - Manual Svc Order, per LSR disconnect | SOMAN | NA |
| | NRC - Electronic Svc Order, per LSR | SOMEK | \$3.50 |
| | NRC - Electronic Svc Order, per LSR disconnect | SOMEK | NA |
| | NRC - OC3 - Incremental Cost - Manual Svc Order vs. Electronic-1st | SOMAN | \$93.12 |
| | NRC - OC3 - Incremental Cost - Manual Svc Order vs. Electronic-Add'l | SOMAN | \$93.12 |
| | NRC - OC3 - Incremental Cost - Manual Svc Order vs. Electronic-Disconnect | SOMAN | NA |
| | NRC - OC3 - Incremental Cost - Manual Svc Order vs. Electronic-Disconnect | SOMAN | NA |
| Interoffice Transport - Dedicated - OC12 | | | |
| | OC12 -per mile per month | 1L5XX | \$84.88 |
| | OC12 -Facility Termination | TBD | \$12,344 |
| | NRC - OC12- Facility Termination - 1st | TBD | \$1,713 |
| | NRC - OC12- Facility Termination - Add'l | TBD | \$516.89 |
| | NRC - OC12 - Facility Termination - Disconnect Chg - 1st | TBD | NA |
| | NRC - OC12 - Facility Termination - Disconnect Chg - Add'l | TBD | NA |
| | NRC - Manual Svc Order, per LSR | SOMAN | \$19.99 |
| | NRC - Manual Svc Order, per LSR disconnect | SOMAN | NA |
| | NRC - Electronic Svc Order, per LSR | SOMEK | \$3.50 |
| | NRC - Electronic Svc Order, per LSR disconnect | SOMEK | NA |
| | NRC - OC12 - Incremental Cost - Manual Svc Order vs. Electronic-1st | SOMAN | \$93.12 |
| | NRC - OC12 - Incremental Cost - Manual Svc Order vs. Electronic-Add'l | SOMAN | \$93.12 |
| | NRC - OC12 - Incremental Cost - Manual Svc Order vs. Elect-Disconnect-1st | SOMAN | NA |
| | NRC - OC12 - Incremental Cost - Manual Svc Order vs. Elect-Disconnect-Add'l | SOMAN | NA |

BELLSOUTH/ADELPHIA RATES
NETWORK ELEMENTS
AND OTHER SERVICES

| UNBUNDLED DEDICATED TRANSPORT - Local Channel | | | KY |
|---|-------|--|----------|
| Interoffice Transport - Dedicated - OC48 | | | |
| OC48 -per mile per month | 1L5XX | | \$138.02 |
| OC48 -Facility Termination per month | TBD | | \$16,017 |
| OC48 -per Interface OC12 on OC48 per month | TBD | | \$1,497 |
| NRC - OC48 - Facility Termination - 1st | TBD | | \$1,713 |
| NRC - OC48 - Facility Termination - Add'l | TBD | | \$516.89 |
| NRC - OC48 - Interface OC12 on OC48 - 1st | TBD | | \$844.21 |
| NRC - OC48 - Interface OC12 on OC48 - Add'l | TBD | | \$516.89 |
| NRC - OC48 - Facility Termination - Disconnect Chg - 1st | TBD | | NA |
| NRC - OC48 - Facility Termination - Disconnect Chg - Add'l | TBD | | NA |
| NRC - OC48 - Interface OC12 on OC48 - Disconnect - 1st | TBD | | NA |
| NRC - OC48 - Interface OC12 on OC48 - Disconnect - Add'l | TBD | | NA |
| NRC - Manual Svc Order, per LSR | SOMAN | | \$19.99 |
| NRC - Manual Svc Order, per LSR disconnect | SOMAN | | NA |
| NRC - Electronic Svc Order, per LSR | SOMEK | | \$3.50 |
| NRC - Electronic Svc Order, per LSR disconnect | SOMEK | | NA |
| NRC - OC48 - Incremental Cost - Manual Svc. Order vs. Electronic-1st | SOMAN | | \$93.12 |
| NRC - OC48 - Incremental Cost - Manual Svc. Order vs. Electronic-Add'l | SOMAN | | \$93.12 |
| NRC - OC48 - Interface- Incremental Cost - Manual Svc. Order vs. Electronic | SOMAN | | \$93.12 |
| NRC - OC48 - Interface- Incremental Cost - Manual Svc. Order vs. Electronic-Add'l | SOMAN | | \$93.12 |
| NRC - OC48 - Incremental Cost - Manual Svc. Order vs. Elect-Disconnect-1st | SOMAN | | NA |
| NRC - OC48 - Incremental Cost - Manual Svc. Order vs. Elect-Disconnect-Add'l | SOMAN | | NA |
| NRC - OC48-Interface-Incremental Cost-Manual Svc. Order vs. Elec-Disconnect-Add'l | SOMAN | | NA |
| NRC - OC48-Interface-Incremental Cost-Manual Svc. Order vs. Elec-Disconnect-Add'l | SOMAN | | NA |
| UNBUNDLED CHANNELIZATION | | | |
| DS3 Channelization (DS3 to DS1) | | | |
| per Channelized System (28 DS1) per month | MQ3 | | \$236.32 |
| NRC - 1st | MQ3 | | \$425.41 |
| NRC - Add'l | MQ3 | | \$303.33 |
| NRC -1st - Disconnect | MQ3 | | NA |
| NRC -Add'l - Disconnect | MQ3 | | NA |
| per Interface per month (COCI) | UC1D1 | | \$8.52 |
| NRC - 1st | UC1D1 | | \$15.86 |
| NRC - Add'l | UC1D1 | | \$11.36 |
| NRC - Manual Svc Order, per LSR | SOMAN | | \$19.99 |
| NRC - Manual Svc Order, per LSR disconnect | SOMAN | | NA |
| NRC - Electronic Svc Order, per LSR | SOMEK | | \$3.50 |
| NRC - Electronic Svc Order, per LSR disconnect | SOMEK | | NA |
| Channel System - Incremental Cost - Manual Svc. Order vs. Electronic -1st | SOMAN | | \$41.47 |
| Channel System - Incremental Cost - Manual Svc. Order vs. Electronic -Add'l | SOMAN | | \$11.99 |
| Incremental Cost-Manual Svc. Order vs. Elect -Disconnect - 1st | SOMAN | | NA |
| Incremental Cost-Manual Svc. Order vs. Elect -Disconnect - Add'l | SOMAN | | NA |
| DS1 Channelization (DS1 to DS0) | | | |
| per Channelized System (24 DS0) per month | MQ1 | | \$200.01 |
| NRC - 1st | MQ1 | | \$302.82 |
| NRC - Add'l | MQ1 | | \$184.20 |
| NRC -1sr - Disconnect | MQ1 | | NA |
| NRC -Add'l - Disconnect | MQ1 | | NA |
| - Interface (COCI) | | | |
| per OCU-DP(data) card per month (2.4-64kbs) | 1D1DD | | \$2.94 |
| NRC - 1st | 1D1DD | | \$15.86 |
| NRC - Add'l | 1D1DD | | \$11.36 |
| per BRITE card per month | UC1CA | | \$4.04 |
| NRC - 1st | UC1CA | | \$15.86 |

BELLSOUTH/ADELPHIA RATES
 NETWORK ELEMENTS
 AND OTHER SERVICES

| UNBUNDLED DEDICATED TRANSPORT - Local Channel | | | KY |
|---|--|-------|------------|
| | NRC - Add'l | UC1CA | \$11.36 |
| | per VG card per month (DS0) | 1D1VG | \$1.40 |
| | NRC - 1st | 1D1VG | \$15.86 |
| | NRC - Add'l | 1D1VG | \$11.36 |
| | NRC - Manual Svc Order, per LSR | SOMAN | \$19.99 |
| | NRC - Manual Svc Order, per LSR disconnect | SOMAN | NA |
| | NRC - Electronic Svc Order, per LSR | SOMEK | \$3.50 |
| | NRC - Electronic Svc Order, per LSR disconnect | SOMAN | NA |
| | Channel System - Incremental Cost - Manual Svc. Order vs. Electronic -1st | SOMAN | \$41.47 |
| | Channel System - Incremental Cost - Manual Svc. Order vs. Electronic -Add'l | SOMAN | \$11.99 |
| | Incremental Cost-Manual Svc. Order vs. Elect -Disconnect - 1st | SOMAN | NA |
| | Incremental Cost-Manual Svc. Order vs. Elect -Disconnect - Add'l | SOMAN | NA |
| UNBUNDLED DARK FIBER | | | |
| | Dark Fiber - Interoffice (four fiber strands) per route mile or fraction thereof, per month | 1L5DF | \$31.95 |
| | NRC - Per each four-fiber dark fiber arrangement - 1st | UDF14 | \$1,741.00 |
| | NRC - Per each four-fiber dark fiber arrangement - Add'l | UDF14 | \$563.75 |
| | NRC -Disconnect--1st | UDF14 | NA |
| | NRC -Disconnect--Add'l | UDF14 | NA |
| | Dark Fiber - Local Channel(four fiber strands) per route mile or fraction thereof, per month | 1L5DC | \$49.07 |
| | NRC - Per each four-fiber dark fiber arrangement - 1st | UDFC4 | \$1,741.00 |
| | NRC - Per each four-fiber dark fiber arrangement - Add'l | UDFC4 | \$563.75 |
| | NRC -Disconnect--1st | UDFC4 | NA |
| | NRC -Disconnect--Add'l | UDFC4 | NA |
| | Dark Fiber - Local Loop (four fiber strands) per route mile or fraction thereof, per month | 1L5DL | \$49.07 |
| | NRC - Per each four-fiber dark fiber arrangement - 1st | UDFL4 | \$1,741.00 |
| | NRC - Per each four-fiber dark fiber arrangement - Add'l | UDFL4 | \$563.75 |
| | NRC -Disconnect--1st | UDFL4 | NA |
| | NRC -Disconnect--Add'l | UDFL4 | NA |

BELLSOUTH/ADELPHIA RATES
NETWORK ELEMENTS
AND OTHER SERVICES

| DESCRIPTION | | | KY |
|---|-------|--|----|
| UNBUNDLED LOOP COMBINATIONS | | | |
| Unbundled Loop/Port Combinations (Note 4) | | | |
| MARKET RATES (INCLUDING ALL VERTICAL FEATURES) (Note 1) | | | |
| Density Zone 1 / Top 8 MSAs in BellSouth Region | | | |
| Customers with 4 or more DS0 Equivalent | | | |
| Currently Combined (Note2) | | | |
| 2-Wire Voice Grade Loop with 2-Wire Line Port (Res. and Bus.) | | | |
| 2-Wire Voice Grade Line Port (Res.), per month | | | |
| 2-wire voice unbundled port - residence | UEPRL | | NA |
| 2-wire voice unbundled port with caller ID - residence | UEPRC | | NA |
| 2-wire voice unbundled port outgoing only - residence | UEPRO | | NA |
| 2-wire voice grade unbundled Alabama extended local dialing parity port with caller ID | UEPAR | | NA |
| 2-wire voice grade unbundled Kentucky extended local dialing parity port with caller ID | UEPRM | | NA |
| 2-wire voice grade unbundled Louisiana extended local dialing parity port with caller ID | UEPAS | | NA |
| 2-wire voice grade unbundled Mississippi extended local dialing parity port with caller ID | UEPAT | | NA |
| 2-wire voice grade unbundled South Carolina extended local dialing parity port with caller ID | UEPAU | | NA |
| 2-wire voice grade unbundled Tennessee extended local dialing parity port with caller ID | UEPAQ | | NA |
| 2-wire voice unbundled Florida area calling with caller ID - residence | UEPAF | | NA |
| 2-wire voice unbundled Louisiana Area Plus with caller ID - residence (RUL) | UEPAG | | NA |
| 2-wire voice unbundled Louisiana Area Plus with caller ID - residence (AC7) | UEPAH | | NA |
| 2-wire voice unbundled South Carolina Area Calling port with Caller ID - residence (LW8) | UEPAJ | | NA |
| 2-wire voice unbundled Tennessee Area Calling port with Caller ID - residence (F2R) | UEPAK | | NA |
| 2-wire voice unbundled Tennessee Area Calling port with Caller ID - residence (TACER) | UEPAL | | NA |
| 2-wire voice unbundled Tennessee Area Calling port with Caller ID - residence (TACSR) | UEPAM | | NA |
| 2-wire voice unbundled Tennessee Area Calling port with Caller ID - residence (1MF2X) | UEPAN | | NA |
| 2-wire voice unbundled Tennessee Area Calling port with Caller ID - residence (2MR) | UEPAO | | NA |
| 2-wire voice unbundled res. low usage line port with Caller ID (LUM) | UEPAP | | NA |
| 2-Wire Voice Grade Line Port (Bus.), per month | | | |
| 2-wire voice unbundled port without Caller ID | UEPBL | | NA |
| 2-wire voice unbundled port with unbundled port with Caller+E484 ID | UEPBC | | NA |
| 2-wire voice unbundled outgoing only port | UEPBO | | NA |
| 2-wire voice grade unbundled Alabama extended local dialing parity port with caller ID | UEPAW | | NA |
| 2-wire voice grade unbundled Kentucky extended local dialing parity port with caller ID | UEPBM | | NA |
| 2-wire voice grade unbundled Louisiana extended local dialing parity port with caller ID | UEPAX | | NA |

BELLSOUTH/ADELPHIA RATES
NETWORK ELEMENTS
AND OTHER SERVICES

| DESCRIPTION | | KY |
|---|--------|----|
| 2-wire voice grade unbundled Mississippi extended local dialing parity port with caller ID | UEPAY | NA |
| 2-wire voice grade unbundled South Carolina extended local dialing parity port with caller ID | UEPAZ | NA |
| 2-wire voice grade unbundled Tennessee extended local dialing parity port with caller ID | UEPAV | NA |
| 2-wire voice unbundled incoming only port with Caller ID | UEPB1 | NA |
| 2-wire voice unbundled LA Bus Area Calling Port with Caller ID (BUC) | UEPAA | NA |
| 2-wire voice unbundled SC Bus Area Calling Port with Caller ID (LMB) | UEPAB | NA |
| 2-wire voice unbundled TN Bus 2-Way Area Calling Port Economy Option (TACC1) | UEPAC | NA |
| 2-wire voice unbundled TN Bus 2-Way Area Calling Port Standard Option (TACC2) | UEPAD | NA |
| 2-wire voice unbundled TN Bus 2-WAY Collierville and Memphis Local Calling Port (B2F) | UEPAE | NA |
| 2-Wire Voice Grade Loop (SL1) (Res. and Bus.) | | |
| RC - 2-Wire Voice Grade Loop - Statewide | UEPLX | NA |
| RC - 2-Wire Voice Grade Loop Zone 1 | UEPLX | NA |
| RC - 2-Wire Voice Grade Loop Zone 2 | UEPLX | NA |
| RC - 2-Wire Voice Grade Loop Zone 3 | UEPLX | NA |
| Combination Rates | | |
| RC - 2-Wire Voice Grade Loop with 2-Wire Line Port, Statewide | Note 8 | NA |
| RC - 2-Wire Voice Grade Loop with 2-Wire Line Port, Zone 1 (Note 6) | Note 8 | NA |
| RC - 2-Wire Voice Grade Loop with 2-Wire Line Port, Zone 2 (Note 6) | Note 8 | NA |
| RC - 2-Wire Voice Grade Loop with 2-Wire Line Port, Zone 3 (Note 6) | Note 8 | NA |
| Nonrecurring Charges | | |
| 2-Wire Voice Grade Line Port (Res. And Bus.) | | |
| NRC - 2- wire voice grade unbundled port/loop combination - 1st, with change | TBD | NA |
| NRC - 2- wire voice grade unbundled port/loop combination - Add'l, with change | TBD | NA |
| NRC - 2- wire voice grade unbundled port/loop combination - 1st, no change | TBD | NA |
| NRC - 2- wire voice grade unbundled port/loop combination - Add'l, no change | TBD | NA |
| NRC - 2-Wire Voice Grade Loop/Line Port Combination - Subsequent | TBD | NA |
| NRC - 2-Wire Voice Grade Loop/Line Port Combination - OSS LSR Charge, Electronic, per LSR received from the CLEC by one of the OSS interactive interfaces | SOMEK | NA |
| NRC - 2-Wire Voice Grade Loop/Line Port Combination - Incremental Cost - Manual Svc.Order vs. Electronic - 1st | SOMAN | NA |
| NRC - 2-Wire Voice Grade Loop/Line Port Combination - Incremental Cost - Manual Svc.Order vs. Electronic - Add'l | SOMAN | NA |
| NRC - 2 Wire Voice Grade Loop/Line Port Combination - Subsequent Database Update - Electronic | TBD | NA |
| NRC - 2 Wire Voice Grade Loop/Line Port Combination - Subsequent Database Update - Manual Service Order | TBD | NA |
| NRC - Incremental Manual Service Order Disconnect | TBD | NA |
| 2-Wire Voice Grade Loop with 2-Wire Line Port PBX | | |
| 2-Wire Analog Line Port (PBX), per month | | |
| 2 WIRE VOICE UNBUNDLED COMBINATION 2-WAY PBX TRUNK - Residence | UEPRD | NA |

BELLSOUTH/ADELPHIA RATES
NETWORK ELEMENTS
AND OTHER SERVICES

| DESCRIPTION | | KY |
|--|-------|----|
| LINE SIDE UNBUNDLED COMBINATION 2-WAY PBX TRUNK - BUSINESS | UEPPC | NA |
| LINE SIDE UNBUNDLED OUTWARD PBX TRUNK - BUSINESS | UEPPO | NA |
| LINE SIDE UNBUNDLED INCOMING PBX TRUNK - BUSINESS | UEPP1 | NA |
| 2-WIRE VOICE UNBUNDLED 2-WAY COMBINATION PBX ALABAMA CALLING PORT | UEPA2 | NA |
| 2-WIRE VOICE UNBUNDLED 2-WAY COMBINATION PBX LOUISIANA CALLING PORT | UEPL2 | NA |
| 2-WIRE VOICE UNBUNDLED PBX LD TERMINAL PORTS | UEPLD | NA |
| 2-WIRE VOICE UNBUNDLED 2-WAY COMBINATION PBX TENNESSEE CALLING PORT | UEPT2 | NA |
| 2-WIRE VOICE UNBUNDLED 1-WAY OUTGOING PBX TENNESSEE CALLING PORT | UEPTO | NA |
| 2-WIRE VOICE UNBUNDLED 2-WAY COMBINATION PBX USAGE PORT | UEPXA | NA |
| 2-WIRE VOICE UNBUNDLED PBX TOLL TERMINAL HOTEL PORTS | UEPXB | NA |
| 2-WIRE VOICE UNBUNDLED PBX LD DDD TERMINALS PORT | UEPXC | NA |
| 2-WIRE VOICE UNBUNDLED PBX LD TERMINAL SWITCHBOARD PORT | UEPXD | NA |
| 2-WIRE VOICE UNBUNDLED PBX LD TERMINAL SWITCHBOARD IDD CAPABLE PORT | UEPXE | NA |
| 2-WIRE VOICE UNBUNDLED 2-WAY PBX KENTUCKY ROOM AREA CALLING PORT WITHOUT LUD | UEPXF | NA |
| 2-WIRE VOICE UNBUNDLED PBX KENTUCKY LUD AREA CALLING PORT | UEPXG | NA |
| 2-WIRE VOICE UNBUNDLED PBX KENTUCKY PREMIUM CALLING PORT | UEPXH | NA |
| 2-WIRE VOICE UNBUNDLED 2-WAY KENTUCKY AREA CALLING PORT WITHOUT LUD | UEPXJ | NA |
| 2-WIRE VOICE UNBUNDLED 2-WAY PBX LOUISIANA LOCAL OPTIONAL CALLING PORT | UEPXK | NA |
| 2-WIRE VOICE UNBUNDLED 2-WAY PBX HOTEL/HOSPITAL ECONOMY ADMINISTRATIVE CALLING PORT | UEPXL | NA |
| 2-WIRE VOICE UNBUNDLED 2-WAY PBX HOTEL/HOSPITAL ECONOMY ROOM CALLING PORT | UEPXM | NA |
| 2-WIRE VOICE UNBUNDLED 1-WAY OUTGOING PBX HOTEL/HOSPITAL ECONOMY ADMINIATRATIVE CALLING PORTTENNESSEE CALLING PORT | UEPXN | NA |
| 2-WIRE VOICE UNBUNDLED 1-WAY OUTGOING PBX HOTEL/HOSPITAL DIACOUNT ROOM CALLING PORT | UEPXO | NA |
| 2-WIRE VOICE UNBUNDLED 1-WAY OUTGOING PBX LOUISIANA LOCAL DISCOUNT CALLING PORT | UEPXP | NA |
| 2-WIRE VOICE UNBUNDLED 2-WAY PBX MISSISSIPPI LOCAL ECONOMY CALLING PORT | UEPXQ | NA |
| 2-WIRE VOICE UNBUNDLED 2-WAY PBX MISSISSIPPI LOCAL OPTIONAL CALLING PORT | UEPXR | NA |
| 2-WIRE VOICE UNBUNDLED 1-WAY OUTGOING PBXMEASURED PORT | UEPXS | NA |
| 2-WIRE VOICE UNBUNDLED 2-WAY PBX SOUTH CAROLINA AREA PLUS CALLING PORT | UEPXT | NA |
| 2-WIRE VOICE UNBUNDLED PBX COLLIERVILLE & MEMPHIS CALLING PORT | UEPXU | NA |
| 2-WIRE VOICE UNBUNDLED 2-WAY PBX TENNESSEE REGIONSERV CALLING PORT | UEPXV | NA |
| LOCAL NUMBER PORTABILITY (REQUIRES ONE PER PORT) | LNPCP | |
| 2-Wire Voice Grade Loop (SL1) | | |

BELLSOUTH/ADELPHIA RATES
NETWORK ELEMENTS
AND OTHER SERVICES

| DESCRIPTION | | KY |
|--|--------|---------|
| RC - 2- Wire Voice Grade Loop - Statewide | UEPLX | NA |
| RC - 2- Wire Voice Grade Loop - Zone 1 | UEPLX | NA |
| RC - 2- Wire Voice Grade Loop - Zone 2 | UEPLX | NA |
| RC - 2- Wire Voice Grade Loop - Zone 3 | UEPLX | NA |
| RC - 2- Wire Voice Grade Loop - Zone 4 | UEPLX | NA |
| Combination Rates | | |
| RC - 2-Wire Voice Grade Loop with 2-Wire Line Port, Statewide | Note 8 | NA |
| RC - 2-Wire Voice Grade Loop with 2-Wire Line Port, Zone 1 (Note 6) | Note 8 | NA |
| RC - 2-Wire Voice Grade Loop with 2-Wire Line Port, Zone 2 (Note 6) | Note 8 | NA |
| RC - 2-Wire Voice Grade Loop with 2-Wire Line Port, Zone 3 (Note 6) | Note 8 | NA |
| Nonrecurring Charges | | |
| NRC - 2- wire voice grade unbundled port/loop combination - 1st, with change | TBD | NA |
| NRC - 2- wire voice grade unbundled port/loop combination - Add'l, with change | TBD | NA |
| NRC - 2- wire voice grade unbundled port/loop combination - 1st, no change | TBD | NA |
| NRC - 2- wire voice grade unbundled port/loop combination - Add'l, no change | TBD | NA |
| NRC - 2-Wire Voice Grade Loop/Line Port Combination - Subsequent | TBD | \$10.00 |
| NRC - 2-Wire Voice Grade Loop/Line Port Combination - OSS LSR Charge, Electronic, per LSR received from the CLEC by one of the OSS interactive interfaces (Note 7) | SOMEK | NA |
| NRC - 2-Wire Voice Grade Loop/Line Port Combination - Incremental Cost - Manual Svc.Order vs. Electronic - 1st | SOMAN | NA |
| NRC - 2-Wire Voice Grade Loop/Line Port Combination - Incremental Cost - Manual Svc.Order vs. Electronic - Add'l | SOMAN | NA |
| NRC- 2 Wire Voice Grade Loop/Line Port Combination - Subsequent Database Update - Electronic | TBD | NA |
| NRC- 2 Wire Voice Grade Loop/Line Port Combination - Subsequent Database Update - Manual Service Order | TBD | NA |
| NRC - Incremental Manual Service Order Disconnect | TBD | NA |
| COST BASED RATES (Notes 2 & 3) | | |
| Currently Combined | | |
| 2-Wire Voice Grade Loop with 2-Wire Line Port | | |
| 2-Wire Voice Grade Line Port (Res.), per month | | |
| 2- wire voice unbundled port - residence | UEPRL | \$2.61 |
| 2-wire voice unbundled port with caller ID - residence | UEPRC | \$2.61 |
| 2-wire voice unbundled port outgoing only - residence | UEPRO | \$2.61 |
| 2-wire voice grade unbundled Alabama extended local dialing parity port with caller ID | UEPAR | NA |
| 2-wire voice grade unbundled Kentucky extended local dialing parity port with caller ID | UEPRM | \$2.61 |
| 2-wire voice grade unbundled Louisiana extended local dialing parity port with caller ID | UEPAS | NA |
| 2-wire voice grade unbundled Mississippi extended local dialing parity port with caller ID | UEPAT | NA |
| 2-wire voice grade unbundled South Carolina extended local dialing parity port with caller ID | UEPAU | NA |

BELLSOUTH/ADELPHIA RATES
NETWORK ELEMENTS
AND OTHER SERVICES

| DESCRIPTION | | KY |
|---|--------|---------|
| 2-wire voice grade unbundled Tennessee extended local dialing parity port with caller ID | UEPAQ | NA |
| 2-wire voice unbundled area plus port with caller ID - residence | UEPRM | \$2.61 |
| 2-wire voice unbundled Florida area calling with caller ID - residence | UEPAF | NA |
| 2-wire voice unbundled Louisiana Area Plus with caller ID - residence (RUL) | UEPAG | NA |
| 2-wire voice unbundled Louisiana Area Plus with caller ID - residence (AC7) | UEPAH | NA |
| 2-wire voice unbundled South Carolina Area Calling port with Caller ID - residence (LW8) | UEPAJ | NA |
| 2-wire voice unbundled Tennessee Area Calling port with Caller ID - residence (F2R) | UEPAK | NA |
| 2-wire voice unbundled Tennessee Area Calling port with Caller ID - residence (TACER) | UEPAL | NA |
| 2-wire voice unbundled Tennessee Area Calling port with Caller ID - residence (TACSR) | UEPAM | NA |
| 2-wire voice unbundled Tennessee Area Calling port with Caller ID - residence (1MF2X) | UEPAN | NA |
| 2-wire voice unbundled Tennessee Area Calling port with Caller ID - residence (2MR) | UEPAO | NA |
| 2-wire voice unbundled res, low usage line port with Caller ID (LUM) | UEPAP | \$2.61 |
| 2-Wire Voice Grade Line Port (Bus.), per month | | |
| 2-wire voice unbundled port without Caller ID | UEPBL | \$2.61 |
| 2-wire voice unbundled port with unbundled port with Caller+E484 ID | UEPBC | \$2.61 |
| 2-wire voice unbundled outgoing only port | UEPBO | \$2.61 |
| 2-wire voice grade unbundled Alabama extended local dialing parity port with caller ID | UEPAW | NA |
| 2-wire voice grade unbundled Kentucky extended local dialing parity port with caller ID | UEPBM | \$2.61 |
| 2-wire voice grade unbundled Louisiana extended local dialing parity port with caller ID | UEPAX | NA |
| 2-wire voice grade unbundled Mississippi extended local dialing parity port with caller ID | UEPAY | NA |
| 2-wire voice grade unbundled South Carolina extended local dialing parity port with caller ID | UEPAZ | NA |
| 2-wire voice grade unbundled Tennessee extended local dialing parity port with caller ID | UEPAV | NA |
| 2-wire voice unbundled incoming only port with Caller ID | UEPB1 | \$2.61 |
| 2-wire voice unbundled LA Bus Area Calling Port with Caller ID (BUC) | UEPAA | NA |
| 2-wire voice unbundled SC Bus Area Calling Port with Caller ID (LMB) | UEPAB | NA |
| 2-wire voice unbundled TN Bus 2-Way Area Calling Port Economy Option (TACC1) | UEPAC | NA |
| 2-wire voice unbundled TN Bus 2-Way Area Calling Port Standard Option (TACC2) | UEPAD | NA |
| 2-wire voice unbundled TN Bus 2-WAY Collierville and Memphis Local Calling Port (B2F) | UEPAE | NA |
| 2-Wire Voice Grade Loop (SL1) | | |
| RC - 2- Wire Voice Grade Loop - Statewide | UEPLX | NA |
| RC - 2- Wire Voice Grade Loop - Zone 1 | UEPLX | \$14.79 |
| RC - 2- Wire Voice Grade Loop - Zone 2 | UEPLX | \$27.68 |
| RC - 2- Wire Voice Grade Loop - Zone 3 | UEPLX | \$47.78 |
| RC - 2- Wire Voice Grade Loop - Zone 4 | UEPLX | NA |
| Combination Rates | | |
| RC - 2-Wire Voice Grade Loop with 2-Wire Line Port, Statewide | Note 8 | NA |
| RC - 2-Wire Voice Grade Loop with 2-Wire Line Port, Zone 1 (Note 6) | Note 8 | \$17.40 |
| RC - 2-Wire Voice Grade Loop with 2-Wire Line Port, Zone 2 (Note 6) | Note 8 | \$30.29 |
| RC - 2-Wire Voice Grade Loop with 2-Wire Line Port, Zone 3 (Note 6) | Note 8 | \$50.39 |

BELLSOUTH/ADELPHIA RATES
NETWORK ELEMENTS
AND OTHER SERVICES

| DESCRIPTION | | KY |
|--|--------|---------|
| RC - 2-Wire Voice Grade Loop with 2-Wire Line Port, Zone 4 (Note 6) | Note 8 | NA |
| Nonrecurring Charges | | |
| NRC - 2-Wire Voice Grade Loop/Line Port Combination - 1st, Switch as is | USAC2 | \$10.00 |
| NRC - 2-Wire Voice Grade Loop/Line Port Combination - Add'l, Switch as is | USAC2 | \$10.00 |
| NRC - 2-Wire Voice Grade Loop/Line Port Combination - 1st, Switch with change | USACC | \$10.00 |
| NRC - 2-Wire Voice Grade Loop/Line Port Combination - Add'l, Switch with change | USACC | \$10.00 |
| NRC - 2-Wire Voice Grade Loop/Line Port Combination - Subsequent | USAS2 | \$10.00 |
| NRC - 2-Wire Voice Grade Loop/Line Port Combination - OSS LSR Charge, Electronic, per LSR received from the CLEC by one of the OSS interactive interfaces (Note 7) | SOMEK | \$3.50 |
| NRC - 2-Wire Voice Grade Loop/Line Port Combination - Incremental Cost - Manual Svc.Order vs. Electronic - 1st | SOMAN | \$19.99 |
| NRC - 2-Wire Voice Grade Loop/Line Port Combination - Incremental Cost - Manual Svc.Order vs. Electronic - Add'l | SOMAN | \$19.99 |
| NRC - 2 Wire Voice Grade Loop/Line Port Combination - Subsequent Database Update - Electronic | TBD | TBD |
| NRC - 2 Wire Voice Grade Loop/Line Port Combination - Subsequent Database Update - Manual Service Order | TBD | TBD |
| NRC - Incremental Manual Service Order Disconnect | TBD | \$20.00 |
| NRCs for New (not Currently Combined) as ordered in Georgia: | | |
| NRC - 2-Wire Voice Grade Loop with 2-Wire Line Port - New - 1st | UEPRL | NA |
| NRC - 2-Wire Voice Grade Loop with 2-Wire Line Port - New - Add'l | UEPRL | NA |
| NRC - 2-Wire Voice Grade Loop with 2-Wire Line Port - New - 1st | UEPRC | NA |
| NRC - 2-Wire Voice Grade Loop with 2-Wire Line Port - New - Add'l | UEPRC | NA |
| NRC - 2-Wire Voice Grade Loop with 2-Wire Line Port - New - 1st | UEPRO | NA |
| NRC - 2-Wire Voice Grade Loop with 2-Wire Line Port - New - Add'l | UEPRO | NA |
| NRC - 2-Wire Voice Grade Loop with 2-Wire Line Port - New - 1st | UEPAP | NA |
| NRC - 2-Wire Voice Grade Loop with 2-Wire Line Port - New - Add'l | UEPAP | NA |
| NRC - 2-Wire Voice Grade Loop with 2-Wire Line Port - New - 1st | UEPBL | NA |
| NRC - 2-Wire Voice Grade Loop with 2-Wire Line Port - New - Add'l | UEPBL | NA |
| NRC - 2-Wire Voice Grade Loop with 2-Wire Line Port - New - 1st | UEPBC | NA |
| NRC - 2-Wire Voice Grade Loop with 2-Wire Line Port - New - Add'l | UEPBC | NA |
| NRC - 2-Wire Voice Grade Loop with 2-Wire Line Port - New - 1st | UEPBO | NA |
| NRC - 2-Wire Voice Grade Loop with 2-Wire Line Port - New - Add'l | UEPBO | NA |
| NRC - 2-Wire Voice Grade Loop with 2-Wire Line Port - New - 1st | UEPB1 | NA |
| NRC - 2-Wire Voice Grade Loop with 2-Wire Line Port - New - Add'l | UEPB1 | NA |
| NRC - 2-Wire Voice Grade Loop/Line Port Combination - Subsequent | USAS2 | NA |
| NRC - 2-Wire Voice Grade Loop with 2-Wire Line Port - New - Disconnect - 1st | TBD | NA |
| NRC - 2-Wire Voice Grade Loop with 2-Wire Line Port - New - Disconnect - Add'l | TBD | NA |
| NRC - 2-Wire Voice Grade Loop/Line Port Combination - OSS LSR Charge, Electronic, per LSR received from the CLEC by one of the OSS interactive interfaces (Note 7) | SOMEK | NA |
| NRC - 2-Wire Voice Grade Loop with 2-Wire Line Port - Incremental Cost Manual vs. Electronic - New - 1st | TBD | NA |
| NRC - 2-Wire Voice Grade Loop with 2-Wire Line Port - Incremental Cost Manual vs. Electronic - New - Add'l | TBD | NA |

BELLSOUTH/ADELPHIA RATES
NETWORK ELEMENTS
AND OTHER SERVICES

| DESCRIPTION | | KY |
|--|--------|---------|
| NRC- 2 Wire Voice Grade Loop/Line Port Combination - Subsequent Database Update - Electronic | TBD | NA |
| NRC- 2 Wire Voice Grade Loop/Line Port Combination - Subsequent Database Update - Manual Service Order | TBD | NA |
| NRC - 2-Wire Voice Grade Loop with 2-Wire Line Port - Incremental Cost Manual vs. Electronic - New - Disconnect | TBD | NA |
| 2- Wire Voice Grade Loop - Bus Only with 2 -Wire DID Trunk Port | | |
| 2 - Wire Line Port - DID Trunk Port, per month | UEPD1 | TBD |
| 2-Wire Voice Grade Loop (SL2) | | |
| RC - 2- Wire Voice Grade Loop - Statewide | UECD1 | NA |
| RC - 2- Wire Voice Grade Loop - Zone 1 | UECD1 | \$17.27 |
| RC - 2- Wire Voice Grade Loop - Zone 2 | UECD1 | \$32.32 |
| RC - 2- Wire Voice Grade Loop - Zone 3 | UECD1 | \$55.78 |
| RC - 2- Wire Voice Grade Loop - Zone 4 | UECD1 | NA |
| Combination Rates | | |
| RC - 2-Wire Voice Grade Loop with 2-Wire DID Port, Statewide | Note 8 | NA |
| RC - 2-Wire Voice Grade Loop with 2-Wire DID Port, Zone 1 (Note 6) | Note 8 | TBD |
| RC - 2-Wire Voice Grade Loop with 2-Wire DID Port, Zone 2 (Note 6) | Note 8 | TBD |
| RC - 2-Wire Voice Grade Loop with 2-Wire DID Port, Zone 3 (Note 6) | Note 8 | TBD |
| RC - 2-Wire Voice Grade Loop with 2-Wire DID Port, Zone 4 (Note 6) | Note 8 | NA |
| NRC- 2- Wire Voice Grade Loop with 2- Wire DID Port - 1st | TBD | TBD |
| NRC- 2- Wire Voice Grade Loop with 2- Wire DID Port - Addl | TBD | TBD |
| NRC - 2-Wire Voice Grade Loop/Line Port Combination - OSS LSR Charge, Electronic, per LSR received from the CLEC by one of the OSS interactive interfaces (Note 7) | SOMEK | \$3.50 |
| NRC- 2- Wire Voice Grade Loop with 2- Wire DID Port - Incremental Cost- Manual Service Order - 1st | TBD | TBD |
| NRC- 2- Wire Voice Grade Loop with 2- Wire DID Port - Incremental Cost- Manual Service Order - Addl | TBD | TBD |
| 2-Wire ISDN Digital Grade Loop with 2-wire ISDN Digital Port | | |
| 2-wire ISDN Digital Port per month | UEPPB | \$12.33 |
| 2-Wire ISDN Digital Grade Loop | | |
| RC - 2-Wire ISDN Digital Grade Loop - Statewide | USL2X | NA |
| RC - 2-Wire ISDN Digital Grade Loop - Zone 1 | USL2X | \$23.66 |
| RC - 2-Wire ISDN Digital Grade Loop - Zone 2 | USL2X | \$44.28 |
| RC - 2-Wire ISDN Digital Grade Loop - Zone 3 | USL2X | \$76.42 |
| RC - 2-Wire ISDN Digital Grade Loop - Zone 4 | USL2X | NA |
| Combination Rates | | |
| RC - 2-Wire ISDN Digital Grade Loop with 2-wire ISDN Digital Port - Statewide | Note 8 | NA |
| RC - 2-Wire ISDN Digital Grade Loop with 2-wire ISDN Digital Port - Zone 1 | Note 8 | \$35.99 |
| RC - 2-Wire ISDN Digital Grade Loop with 2-wire ISDN Digital Port - Zone 2 | Note 8 | \$56.61 |
| RC - 2-Wire ISDN Digital Grade Loop with 2-wire ISDN Digital Port - Zone 3 | Note 8 | \$88.75 |
| RC - 2-Wire ISDN Digital Grade Loop with 2-wire ISDN Digital Port - Zone 4 | Note 8 | NA |
| NRC - 2-Wire ISDN Digital Grade Loop/2-wire ISDN Digital Port - 1st conversion | USACB | TBD |
| NRC - 2-Wire ISDN Digital Grade Loop/2-wire ISDN Digital Port - Add'l conversion | USACB | TBD |

BELLSOUTH/ADELPHIA RATES
NETWORK ELEMENTS
AND OTHER SERVICES

| DESCRIPTION | | | KY |
|--|--|--|--------------------|
| | | NRC - 2-Wire ISDN Digital Grade Loop/2-wire ISDN Digital Port - Non Feature Subsequent Activity | USASB TBD |
| | | NRC - 2-Wire Voice Grade Loop/Line Port Combination - OSS LSR Charge, Electronic, per LSR received from the CLEC by one of the OSS interactive interfaces (Note 7) | SOMEK \$3.50 |
| 4 - Wire DS1 Digital Loop with 4 - Wire ISDN DS1 Digital Trunk Port | | | |
| | | 4 - Wire ISDN DS1 Digital Trunk Port | UEPPP \$275.48 |
| | | 4 - Wire DS1 Digital Loop | |
| | | RC - 4 - Wire DS1 Digital Loop- Statewide | USL4P NA |
| | | RC - 4 - Wire DS1 Digital Loop- Zone 1 | USL4P \$50.26 |
| | | RC - 4 - Wire DS1 Digital Loop- Zone 2 | USL4P \$94.06 |
| | | RC - 4 - Wire DS1 Digital Loop- Zone 3 | USL4P \$162.34 |
| | | RC - 4-Wire DS1 Digital Loop - Zone 4 | USL4P NA |
| Combination Rates | | | |
| | | RC - 4-Wire DS1 Digital Loop with 4-wire ISDN DS1 Digital Port - Statewide | Note 8 NA |
| | | RC - 4-Wire DS1 Digital Loop with 4-wire ISDN DS1 Digital Port - Zone 1 | Note 8 \$325.74 |
| | | RC - 4-Wire DS1 Digital Loop with 4-wire ISDN DS1 Digital Port - Zone 2 | Note 8 \$369.54 |
| | | RC - 4-Wire DS1 Digital Loop with 4-wire ISDN DS1 Digital Port - Zone 3 | Note 8 \$437.82 |
| | | RC - 4-Wire DS1 Digital Loop with 4-wire ISDN DS1 Digital Port - Zone 4 | Note 8 NA |
| | | NRC - 4-Wire DS1 Digital Loop with 4-wire ISDN DS1 Digital Port Combination - 1st conversion | USACP TBD |
| | | NRC - 4-Wire DS1 Digital Loop with 4-wire ISDN DS1 Digital Port Combination - Add'l conversion | USACP TBD |
| | | NRC - 4 - Wire DS1 Digital Loop with 4 - Wire ISDN DS1 Digital Trunk Port - Subsequent Channel Activation - Per Channel | USASP TBD |
| | | NRC - 4-Wire DS1 Digital Loop with 4-wire ISDN DS1 Digital Port Combination - Subsequent Inward/2-way Telephone Numbers | PR7TG TBD |
| | | NRC - 4-Wire DS1 Digital Loop with 4-wire ISDN DS1 Digital Port Combination - Subsequent Outward Telephone numbers | PR7TP TBD |
| | | NRC - 4-Wire DS1 Digital Loop with 4-wire ISDN DS1 Digital Port Combination - Subsequent Inward Telephone Numbers | PR7ZT TBD |
| | | NRC - 4-Wire DS1 Digital Loop with 4-wire ISDN DS1 Digital Port Combination - Subsequent Service Order Per Order | USASP TBD |
| | | NRC - 2-Wire Voice Grade Loop/Line Port Combination - OSS LSR Charge, Electronic, per LSR received from the CLEC by one of the OSS interactive interfaces (Note 7) | SOMEK \$3.50 |
| 4 - Wire DS1 Digital Loop with 4 - Wire DID Trunk Port | | | |
| | | 4 - Wire DID Trunk Port | TBD TBD |
| | | 4 - Wire DS1 Digital Loop | |
| | | 4 - Wire DS1 Digital Loop - Statewide | TBD NA |
| | | 4 - Wire DS1 Digital Loop - Zone 1 | TBD \$50.26 |
| | | 4 - Wire DS1 Digital Loop - Zone 2 | TBD \$94.06 |
| | | 4 - Wire DS1 Digital Loop - Zone 3 | TBD \$162.34 |
| | | 4 - Wire DS1 Digital Loop - Zone 4 | TBD NA |
| Combination Rates | | | |
| | | 4 - Wire DS1 Digital Loop with 4 - Wire DID Trunk Port - Statewide | Note 8 NA |
| | | 4 - Wire DS1 Digital Loop with 4 - Wire DID Trunk Port - Zone 1 | Note 8 TBD |
| | | 4 - Wire DS1 Digital Loop with 4 - Wire DID Trunk Port - Zone 2 | Note 8 TBD |
| | | 4 - Wire DS1 Digital Loop with 4 - Wire DID Trunk Port - Zone 3 | Note 8 TBD |
| | | 4 - Wire DS1 Digital Loop with 4 - Wire DID Trunk Port - Zone 4 | Note 8 NA |

BELLSOUTH/ADELPHIA RATES
NETWORK ELEMENTS
AND OTHER SERVICES

| DESCRIPTION | | KY |
|--|--------|--------|
| NRC -4 - Wire DS1 Digital Loop with 4 - Wire DID Trunk Port - 1st | TBD | TBD |
| NRC -4 - Wire DS1 Digital Loop with 4 - Wire DID Trunk Port - Addl | TBD | TBD |
| NRC -4 - Wire DS1 Digital Loop with 4 - Wire DIDTrunk Port - Subsequent Channel Activation - Per Channel | TBD | TBD |
| NRC -4 - Wire DS1 Digital Loop with 4 - Wire ISDN DS1 Digital Trunk Port - Subsequent Telephone Numbers | TBD | TBD |
| NRC -4 - Wire DS1 Digital Loop with 4 - Wire ISDN DS1 Digital Trunk Port - Subsequent Signaling Changes | TBD | TBD |
| NRC -4 - Wire DS1 Digital Loop with 4 - Wire ISDN DS1 Digital Trunk Port - Subsequent Service Order Per Order | TBD | TBD |
| NRC -4-Wire DS1 Digital Loop with 4-Wire DID Trunk Port Combination - OSS LSR Charge, Electronic, per LSR received from the CLEC by one of the OSS interactive interfaces (Note 7) | SOMEK | \$3.50 |
| NRC- 4-Wire DS1 Digital Loop with 4-Wire DID Trunk Port - Incremental Cost-Manual Service Order - 1st | TBD | TBD |
| NRC- 4-Wire DS1 Digital Loop with 4-Wire DID Trunk Port - Incremental Cost-Manual Service Order - Add'l | TBD | TBD |
| 2-Wire Voice Grade Loop with 2-Wire Line Port PBX | | |
| 2-Wire Analog Line Port (PBX), per month | | |
| 2 WIRE VOICE UNBUNDLED COMBINATION 2-WAY PBX TRUNK - Residence | UEPRD | \$2.61 |
| LINE SIDE UNBUNDLED COMBINATION 2-WAY PBX TRUNK - BUSINESS | UEPPC | \$2.61 |
| LINE SIDE UNBUNDLED OUTWARD PBX TRUNK - BUSINESS | UEPPO | \$2.61 |
| LINE SIDE UNBUNDLED INCOMING PBX TRUNK - BUSINESS | UEPP1 | \$2.61 |
| 2-WIRE VOICE UNBUNDLED 2-WAY COMBINATION PBX ALABAMA CALLING PORT | UEPA2 | NA |
| 2-WIRE VOICE UNBUNDLED 2-WAY COMBINATION PBX LOUISIANA CALLING PORT | UEPL2 | NA |
| 2-WIRE VOICE UNBUNDLED PBX LD TERMINAL PORTS | UEPLD | \$2.61 |
| 2-WIRE VOICE UNBUNDLED 2-WAY COMBINATION PBX TENNESSEE CALLING PORT | UEPT2 | NA |
| 2-WIRE VOICE UNBUNDLED 1-WAY OUTGOING PBX TENNESSEE CALLING PORT | UEPTO | NA |
| 2-WIRE VOICE UNBUNDLED 2-WAY COMBINATION PBX USAGE PORT | UEPXA | \$2.61 |
| 2-WIRE VOICE UNBUNDLED PBX TOLL TERMINAL HOTEL PORTS | UEPXB | \$2.61 |
| 2-WIRE VOICE UNBUNDLED PBX LD DDD TERMINALS PORT | UEPXC | \$2.61 |
| 2-WIRE VOICE UNBUNDLED PBX LD TERMINAL SWITCHBOARD PORT | UEPXD | \$2.61 |
| 2-WIRE VOICE UNBUNDLED PBX LD TERMINAL SWITCHBOARD IDD CAPABLE PORT | UEPXE | \$2.61 |
| 2-WIRE VOICE UNBUNDLED 2-WAY PBX KENTUCKY ROOM AREA CALLING PORT WITHOUT LUD | UEPXF | \$2.61 |
| 2-WIRE VOICE UNBUNDLED PBX KENTUCKY LUD AREA CALLING PORT | UEPXG | \$2.61 |
| 2-WIRE VOICE UNBUNDLED PBX KENTUCKY PREMIUM CALLING PORT | UEPXH | \$2.61 |
| 2-WIRE VOICE UNBUNDLED 2-WAY KENTUCKY AREA CALLING PORT WITHOUT LUD | UEPXJ | \$2.61 |
| 2-WIRE VOICE UNBUNDLED 2-WAY PBX LOUISIANA LOCAL OPTIONAL CALLING PORT | UEP XK | NA |
| 2-WIRE VOICE UNBUNDLED 2-WAY PBX HOTEL/HOSPITAL ECONOMY ADMINISTRATIVE CALLING PORT | UEPXL | \$2.61 |
| 2-WIRE VOICE UNBUNDLED 2-WAY PBX HOTEL/HOSPITAL ECONOMY ROOM CALLING PORT | UEPXM | \$2.61 |

BELLSOUTH/ADELPHIA RATES
NETWORK ELEMENTS
AND OTHER SERVICES

| DESCRIPTION | | KEY |
|--|--------|---------|
| 2-WIRE VOICE UNBUNDLED 1-WAY OUTGOING PBX HOTEL/HOSPITAL ECONOMY ADMINIATRATIVE CALLING PORTTENNESSEE CALLING PORT | UEPXN | NA |
| 2-WIRE VOICE UNBUNDLED 1-WAY OUTGOING PBX HOTEL/HOSPITAL DIACOUNT ROOM CALLING PORT | UEPXO | \$2.61 |
| 2-WIRE VOICE UNBUNDLED 1-WAY OUTGOING PBX LOUISIANA LOCAL DISCOUNT CALLING PORT | UEXP | NA |
| 2-WIRE VOICE UNBUNDLED 2-WAY PBX MISSISSIPPI LOCAL ECONOMY CALLING PORT | UEPXQ | NA |
| 2-WIRE VOICE UNBUNDLED 2-WAY PBX MISSISSIPPI LOCAL OPTIONAL CALLING PORT | UEPXR | NA |
| 2-WIRE VOICE UNBUNDLED 1-WAY OUTGOING PBXMEASURED PORT | UEPXS | \$2.61 |
| 2-WIRE VOICE UNBUNDLED 2-WAY PBX SOUTH CAROLINA AREA PLUS CALLING PORT | UEPXT | NA |
| 2-WIRE VOICE UNBUNDLED PBX COLLIERVILLE & MEMPHIS CALLING PORT | UEPXU | NA |
| 2-WIRE VOICE UNBUNDLED 2-WAY PBX TENNESSEE REGIONSERV CALLING PORT | UEPXV | NA |
| | | |
| LOCAL NUMBER PORTABILITY (REQUIRES ONE PER PORT) | LNPCP | |
| | | |
| 2-Wire Voice Grade Loop (SL1) | | |
| RC - 2- Wire Voice Grade Loop - Statewide | UEPLX | NA |
| RC - 2- Wire Voice Grade Loop - Zone 1 | UEPLX | \$14.79 |
| RC - 2- Wire Voice Grade Loop - Zone 2 | UEPLX | \$27.68 |
| RC - 2- Wire Voice Grade Loop - Zone 3 | UEPLX | \$47.78 |
| RC - 2- Wire Voice Grade Loop - Zone 4 | UEPLX | NA |
| Combination Rates | | |
| RC - 2-Wire Voice Grade Loop with 2-Wire Line Port, Statewide | Note 8 | NA |
| RC - 2-Wire Voice Grade Loop with 2-Wire Line Port, Zone 1 (Note 6) | Note 8 | #VALUE! |
| RC - 2-Wire Voice Grade Loop with 2-Wire Line Port, Zone 2 (Note 6) | Note 8 | #VALUE! |
| RC - 2-Wire Voice Grade Loop with 2-Wire Line Port, Zone 3 (Note 6) | Note 8 | #VALUE! |
| RC - 2-Wire Voice Grade Loop with 2-Wire Line Port, Zone 4 (Note 6) | Note 8 | NA |
| Nonrecurring Charges | | |
| NRC - 2-Wire Voice Grade Loop/Line Port Combination - 1st, Switch as is | USAC2 | \$10.00 |
| NRC - 2-Wire Voice Grade Loop/Line Port Combination - Add'l, Switch as is | USAC2 | \$10.00 |
| | | |
| NRC - 2-Wire Voice Grade Loop/Line Port Combination - 1st, Switch with change | USACC | \$10.00 |
| | | |
| NRC - 2-Wire Voice Grade Loop/Line Port Combination - Add'l, Switch with change | USACC | \$10.00 |
| NRC - 2-Wire Voice Grade Loop/Line Port Combination - Subsequent | USAS2 | \$10.00 |
| NRC - 2-Wire Voice Grade Loop/Line Port Combination - OSS LSR Charge, Electronic, per LSR received from the CLEC by one of the OSS interactive interfaces (Note 7) | SOME | \$3.50 |
| NRC - 2-Wire Voice Grade Loop/Line Port Combination - Incremental Cost - Manual Svc.Order vs. Electronic - 1st | SOMAN | \$19.99 |
| NRC - 2-Wire Voice Grade Loop/Line Port Combination - Incremental Cost - Manual Svc.Order vs. Electronic - Add'l | SOMAN | \$19.99 |
| | | |
| NRC- 2 Wire Voice Grade Loop/Line Port Combination - Subsequent Database Update - Electronic | TBD | TBD |
| NRC- 2 Wire Voice Grade Loop/Line Port Combination - Subsequent Database Update - Manual Service Order | TBD | TBD |
| NRC - Incremental Manual Service Order Disconnect | TBD | \$20.00 |

BELLSOUTH/ADELPHIA RATES
NETWORK ELEMENTS
AND OTHER SERVICES

| DESCRIPTION | | | KY |
|-------------|--|-------|-----|
| | NRCs for New (not Currently Combined) as ordered in Georgia: | | |
| | NRC - 2-Wire Voice Grade Loop with 2-Wire Line Port - New - 1st | UEPRD | NA |
| | NRC - 2-Wire Voice Grade Loop with 2-Wire Line Port - New - Add'l | UEPRD | NA |
| | NRC - 2-Wire Voice Grade Loop with 2-Wire Line Port - New - 1st | UEPPC | NA |
| | NRC - 2-Wire Voice Grade Loop with 2-Wire Line Port - New - Add'l | UEPPC | NA |
| | NRC - 2-Wire Voice Grade Loop with 2-Wire Line Port - New - 1st | UEPPO | NA |
| | NRC - 2-Wire Voice Grade Loop with 2-Wire Line Port - New - Add'l | UEPPO | NA |
| | NRC - 2-Wire Voice Grade Loop with 2-Wire Line Port - New - 1st | UEPP1 | NA |
| | NRC - 2-Wire Voice Grade Loop with 2-Wire Line Port - New - Add'l | UEPP1 | NA |
| | NRC - 2-Wire Voice Grade Loop with 2-Wire Line Port - New - 1st | UEPLD | NA |
| | NRC - 2-Wire Voice Grade Loop with 2-Wire Line Port - New - Add'l | UEPLD | NA |
| | NRC - 2-Wire Voice Grade Loop with 2-Wire Line Port - New - 1st | UEPXA | NA |
| | NRC - 2-Wire Voice Grade Loop with 2-Wire Line Port - New - Add'l | UEPXA | NA |
| | NRC - 2-Wire Voice Grade Loop with 2-Wire Line Port - New - 1st | UEPXB | NA |
| | NRC - 2-Wire Voice Grade Loop with 2-Wire Line Port - New - Add'l | UEPXB | NA |
| | NRC - 2-Wire Voice Grade Loop with 2-Wire Line Port - New - 1st | UEPXC | NA |
| | NRC - 2-Wire Voice Grade Loop with 2-Wire Line Port - New - Add'l | UEPXC | NA |
| | NRC - 2-Wire Voice Grade Loop with 2-Wire Line Port - New - 1st | UEPXD | NA |
| | NRC - 2-Wire Voice Grade Loop with 2-Wire Line Port - New - Add'l | UEPXD | NA |
| | NRC - 2-Wire Voice Grade Loop with 2-Wire Line Port - New - 1st | UEPXE | NA |
| | NRC - 2-Wire Voice Grade Loop with 2-Wire Line Port - New - Add'l | UEPXE | NA |
| | NRC - 2-Wire Voice Grade Loop with 2-Wire Line Port - New - 1st | UEPXL | NA |
| | NRC - 2-Wire Voice Grade Loop with 2-Wire Line Port - New - Add'l | UEPXL | NA |
| | NRC - 2-Wire Voice Grade Loop with 2-Wire Line Port - New - 1st | UEPXM | NA |
| | NRC - 2-Wire Voice Grade Loop with 2-Wire Line Port - New - Add'l | UEPXM | NA |
| | NRC - 2-Wire Voice Grade Loop with 2-Wire Line Port - New - 1st | UEPXO | NA |
| | NRC - 2-Wire Voice Grade Loop with 2-Wire Line Port - New - Add'l | UEPXO | NA |
| | NRC - 2-Wire Voice Grade Loop with 2-Wire Line Port - New - 1st | UEPXS | NA |
| | NRC - 2-Wire Voice Grade Loop with 2-Wire Line Port - New - Add'l | UEPXS | NA |
| | NRC - 2-Wire Voice Grade Loop/Line Port Combination - Subsequent | USAS2 | NA |
| | NRC - 2-Wire Voice Grade Loop with 2-Wire Line Port - New - Disconnect - 1st | TBD | NA |
| | NRC - 2-Wire Voice Grade Loop with 2-Wire Line Port - New - Disconnect - Add'l | TBD | NA |
| | NRC - 2-Wire Voice Grade Loop/Line Port Combination - OSS LSR Charge, Electronic, per LSR received from the CLEC by one of the OSS interactive interfaces (Note 7) | SOMEK | NA |
| | NRC - 2-Wire Voice Grade Loop with 2-Wire Line Port - Incremental Cost Manual vs. Electronic - New - 1st | TBD | NA |
| | NRC - 2-Wire Voice Grade Loop with 2-Wire Line Port - Incremental Cost Manual vs. Electronic - New - Add'l | TBD | NA |
| | NRC- 2 Wire Voice Grade Loop/Line Port Combination - Subsequent Database Update - Electronic | TBD | NA |
| | NRC- 2 Wire Voice Grade Loop/Line Port Combination - Subsequent Database Update - Manual Service Order | TBD | NA |
| | NRC - 2-Wire Voice Grade Loop with 2-Wire Line Port - Incremental Cost Manual vs. Electronic - New - Disconnect | TBD | NA |
| | All Other Loop/Port Combinations | TBD | TBD |

BELLSOUTH/ADELPHIA RATES
 NETWORK ELEMENTS
 AND OTHER SERVICES

| DESCRIPTION | | | KY |
|---------------|--|-------|----|
| | LOCAL NUMBER PORTABILITY (REQUIRES ONE PER PORT) | LNPCX | |
| NOTES: | | | |
| 1 | Market Rates will apply in those areas where BellSouth is not required to provide circuit switching pursuant to FCC rules. | | |
| 2 | In Georgia, rates will apply for Currently Combined as well as not Currently Combined loop/port combinations unless otherwise identified. | | |
| 3 | In the absence of ordered rates by a State Commission, the recurring rates for Currently Combined combinations of loop/port network elements will be the sum of the recurring rates for the UNEs which make up the combinations, and the nonrecurring rates shall be as set forth in this section. | | |
| 4 | End Office and Tandem Switching Usage and Common Transport Usage rates in the Port section of this rate exhibit shall apply to all combinations of loop/port network elements. | | |
| 5 | Deleted | | |
| 6 | Effective May 1, 2000 statewide rates will be replaced by Deaveraged Loop Rates by Zone where available. Until approximately December 31, 2000 or until such time that BellSouth billing systems have been developed to handle the new zone rate structure, BellSouth will bill at the Zone 1 Deaveraged Loop rate level only. After December 31, 2000 or such time that the billing systems have been developed to handle the new zone rate structure, BellSouth will begin billing pursuant to CLEC-1's interconnection agreement. | | |
| 7 | In the absence of ordered OSS rates by a state commission, BellSouth will offer nationwide rates | | |
| 8 | There is not a unique combination USOC. CLEC should submit the loop and port USOCs. | | |

BELLSOUTH/ADELPHIA RATES
NETWORK ELEMENTS
AND OTHER SERVICES

| ENHANCED EXTENDED LINKS (EELs) | | | |
|--------------------------------|--|-------|----|
| | New EEL rates are the sum of the individual UNE network elements (interoffice transport and loop [channelization if applicable]. | | |
| | | USOC | KY |
| | DS1 Interoffice Channel and 2-wire VG Local Loop EEL: | | |
| | Recurring Charges | | |
| | 2-wire VG Loop per month, statewide | UEAL2 | NA |
| | 2-wire VG Loop per month, Zone 1 (Note 1) | TBD | NA |
| | 2-wire VG Loop per month, Zone 2 (Note 1) | TBD | NA |
| | 2-wire VG Loop per month, Zone 3 (Note 1) | NA | NA |
| | 2-wire VG Loop per month, Zone 4 (Note 1) | NA | NA |
| | Interoffice Channel - Dedicated - DS1 - per mile per month | 1L5XX | NA |
| | Interoffice Channel - Dedicated - DS1 - Facility Termination per month | U1TF1 | NA |
| | DS1 Channelized System per month | MQ1 | NA |
| | VG (COCI) interface card per month | 1D1VG | NA |
| | Non-Recurring Charges - New EEL (Note 2)(Note 3) | | |
| | NRC- DS1 interoffice Facility Termination - 1st | U1TF1 | NA |
| | NRC-DS1 interoffice Facility Termination - Add'l | U1TF1 | NA |
| | NRC-2-wire VG Local Loop - 1st | UEAL2 | NA |
| | NRC-2-wire VG Local Loop - Add'l | UEAL2 | NA |
| | NRC-DS1 Channelization System -1st | MQ1 | NA |
| | NRC-DS1 Channelization System - Add'l | MQ1 | NA |
| | NRC-VG(COCI)interface card -1st | 1D1VG | NA |
| | NRC-VG(COCI)interface card - Add'l | 1D1VG | NA |
| | NRC- 2-wire VG Local Loop and Channelized DS1 Interoffice Combination - E | SOMEc | NA |
| | NRC- 2-wire VG Local Loop and Channelized DS1 Interoffice Combination - M | SOMAN | NA |
| | NRC- 2-wire VG Local Loop and Channelized DS1 Interoffice Combination - M | SOMAN | NA |
| | NRC- 2-wire VG Local Loop and Channelized DS1 Interoffice Combination - M | SOMAN | NA |
| | NRC- 2-wire VG Local Loop and Channelized DS1 Interoffice Combination - M | SOMAN | NA |
| | NRC- 2-wire VG Local Loop and Channelized DS1 Interoffice Combination - M | SOMAN | NA |
| | DS1 Interoffice Channel and 4-wire VG Local Loop EEL: | | |
| | Recurring Charges | | |
| | 4-wire VG Loop per month, statewide | UEAL4 | NA |
| | 4-wire VG Loop per month, Zone 1 (Note 1) | TBD | NA |
| | 4-wire VG Loop per month, Zone 2 (Note 1) | TBD | NA |
| | 4-wire VG Loop per month, Zone 3 (Note 1) | TBD | NA |
| | 4-wire VG Loop per month, Zone 4 (Note 1) | NA | NA |
| | Interoffice Channel - Dedicated - DS1 - per mile per month | 1L5XX | NA |
| | Interoffice Channel - Dedicated - DS1 - Facility Termination per month | U1TF1 | NA |
| | DS1 Channelized System per month | MQ1 | NA |
| | VG (COCI) interface card per month | 1D1VG | NA |
| | Non-Recurring Charges - New EEL (Note 2) (Note 3) | | |
| | NRC- DS1 interoffice Facility Termination - 1st | U1TF1 | NA |
| | NRC-DS1 interoffice Facility Termination - Add'l | U1TF1 | NA |
| | NRC-4-wire VG Local Loop - 1st | UEAL4 | NA |
| | NRC-4-wire VG Local Loop - Add'l | UEAL4 | NA |
| | NRC-DS1 Channelization System -1st | MQ1 | NA |
| | NRC-DS1 Channelization System - Add'l | MQ1 | NA |
| | NRC-VG(COCI)interface card -1st | 1D1VG | NA |
| | NRC-VG(COCI)interface card - Add'l | 1D1VG | NA |
| | NRC-DS1 interoffice channel and 4-wire VG Local Loop Combination - Electro | SOMEc | NA |
| | NRC-DS1 interoffice channel and 4-wire VG Local Loop Combination - Manua | SOMAN | NA |
| | NRC-DS1 interoffice channel and 4-wire VG Local Loop Combination - Manua | SOMAN | NA |
| | NRC-DS1 interoffice channel and 4-wire VG Local Loop Combination - Manua | SOMAN | NA |
| | NRC-DS1 interoffice channel and 4-wire VG Local Loop Combination - Manua | SOMAN | NA |

BELLSOUTH/ADELPHIA RATES
NETWORK ELEMENTS
AND OTHER SERVICES

| ENHANCED EXTENDED LINKS (EELs) | | | |
|--------------------------------|--|-------|----|
| | New EEL rates are the sum of the individual UNE network elements (interoffice transport and loop [channelization if applicable]. | | |
| | | USOC | KY |
| | NRC-DS1 interoffice channel and 4-wire VG Local Loop Combination - Manua | SOMAN | NA |
| | DS1 Interoffice Channel and 2-wire ISDN Local Loop: | | |
| | Recurring Charges | | |
| | 2-wire ISDN Loop per month, statewide | U1L2X | NA |
| | 2-wire ISDN Loop per month, Zone 1 (Note 1) | TBD | NA |
| | 2-wire ISDN Loop per month, Zone 2 (Note 1) | TBD | NA |
| | 2-wire ISDN Loop per month, Zone 3 (Note 1) | TBD | NA |
| | 2-wire ISDN Loop per month, Zone 4 (Note 1) | NA | NA |
| | Interoffice Channel - Dedicated - DS1 - per mile per month | 1L5XX | NA |
| | Interoffice Channel - Dedicated - DS1 - Facility Termination per month | U1TF1 | NA |
| | DS1 Channelized System per month | MQ1 | NA |
| | 2-wire ISDN(BRITE COCI) per month | UC1CA | NA |
| | Non-Recurring Charges - New EEL (Note 2)(Note 3) | | |
| | NRC- DS1 interoffice Facility Termination - 1st | U1TF1 | NA |
| | NRC-DS1 interoffice Facility Termination - Add'l | U1TF1 | NA |
| | NRC- 2-wire ISDN Local Loop - 1st | U1L2X | NA |
| | NRC- 2-wire ISDN Local Loop - Add'l | U1L2X | NA |
| | NRC-DS1 Channelization System -1st | MQ1 | NA |
| | NRC-DS1 Channelization System - Add'l | MQ1 | NA |
| | NRC-2-wire BRITE(COCI)interface card -1st | UC1CA | NA |
| | NRC-2-wire BRITE(COCI)interface card -Add'l | UC1CA | NA |
| | NRC-DS1 interoffice channel and 2-wire ISDN Local Loop Combination - Elec | SOMEK | NA |
| | NRC-DS1 interoffice channel and 2-wire ISDN Local Loop Combination - Mar | SOMAN | NA |
| | NRC-DS1 interoffice channel and 2-wire ISDN Local Loop Combination - Mar | SOMAN | NA |
| | NRC-DS1 interoffice channel and 2-wire ISDN Local Loop Combination - Mar | SOMAN | NA |
| | NRC-DS1 interoffice channel and 2-wire ISDN Local Loop Combination - Mar | SOMAN | NA |
| | NRC-DS1 interoffice channel and 2-wire ISDN Local Loop Combination - Mar | SOMAN | NA |
| | DS1 Interoffice Channel and 4-wire 56 kbps Local Loop: | | |
| | Recurring Charges | | |
| | 4-wire 56kbps Loop per month, statewide | UDL56 | NA |
| | 4-wire 56kbps Loop per month, Zone 1 (Note 1) | TBD | NA |
| | 4-wire 56kbps Loop per month, Zone 2 (Note 1) | TBD | NA |
| | 4-wire 56kbps Loop per month, Zone 3 (Note 1) | TBD | NA |
| | 4-wire 56kbps Loop per month, Zone 4 (Note 1) | NA | NA |
| | Interoffice Channel - Dedicated - DS1 - per mile per month | 1L5XX | NA |
| | Interoffice Channel - Dedicated - DS1 - Facility Termination per month | U1TF1 | NA |
| | DS1 Channelized System per month | MQ1 | NA |
| | 4-wire 56kbps card COCI per month | 1D1DD | NA |
| | Non-Recurring Charges - New EEL (Note 2) (Note 3) | | |
| | NRC- DS1 interoffice Facility Termination - 1st | U1TF1 | NA |
| | NRC-DS1 interoffice Facility Termination - Add'l | U1TF1 | NA |
| | NRC-4-wire 56kbps Local Loop - 1st | UDL56 | NA |
| | NRC-4-wire 56kbps Local Loop - Add'l | UDL56 | NA |
| | NRC-DS1 Channelization System -1st | MQ1 | NA |
| | NRC-DS1 Channelization System - Add'l | MQ1 | NA |
| | NRC-4-wire 56kbps(COCI)interface card -1st | 1D1DD | NA |
| | NRC-4-wire 56kbps(COCI)interface card -Add'l | 1D1DD | NA |
| | NRC-DS1 interoffice channel and 4-wire 56kbps Local Loop Combination - E | SOMEK | NA |
| | NRC-DS1 interoffice channel and 4-wire 56kbps Local Loop Combination - M | SOMAN | NA |
| | NRC-DS1 interoffice channel and 4-wire 56kbps Local Loop Combination - M | SOMAN | NA |

BELLSOUTH/ADELPHIA RATES
NETWORK ELEMENTS
AND OTHER SERVICES

| ENHANCED EXTENDED LINKS (EELs) | | | |
|--|---|-------|----|
| New EEL rates are the sum of the individual UNE network elements (interoffice transport and loop [channelization if applicable]. | | | |
| | | USOC | KY |
| | NRC-DS1 interoffice channel and 4-wire 56kbps Local Loop Combination - M | SOMAN | NA |
| | NRC-DS1 interoffice channel and 4-wire 56kbps Local Loop Combination - M | SOMAN | NA |
| | NRC-DS1 interoffice channel and 4-wire 56kbps Local Loop Combination - M | SOMAN | NA |
| DS1 Interoffice Channel and 4-wire 64 kbps Local Loop: | | | |
| Recurring Charges | | | |
| | 4-wire 64kbps Loop per month, statewide | UDL64 | NA |
| | 4-wire 64kbps Loop per month, Zone 1 (Note 1) | TBD | NA |
| | 4-wire 64kbps Loop per month, Zone 2 (Note 1) | TBD | NA |
| | 4-wire 64kbps Loop per month, Zone 3 (Note 1) | TBD | NA |
| | 4-wire 64kbps Loop per month, Zone 4 (Note 1) | NA | NA |
| | Interoffice Channel - Dedicated - DS1 - per mile per month | 1L5XX | NA |
| | Interoffice Channel - Dedicated - DS1 - Facility Termination per month | U1TF1 | NA |
| | DS1 Channelized System per month | MQ1 | NA |
| | 4-wire 64kbps card COCI per month | 1D1DD | NA |
| Non-Recurring Charges - New EEL (Note 2) (Note 3) | | | |
| | NRC- DS1 interoffice - 1st | U1TF1 | NA |
| | NRC- DS1 interoffice - Add'l | U1TF1 | NA |
| | NRC-4-wire 64kbps Local Loop - 1st | UDL64 | NA |
| | NRC-4-wire 64kbps Local Loop - Add'l | UDL64 | NA |
| | NRC-DS1 Channelization System -1st | MQ1 | NA |
| | NRC-DS1 Channelization System - Add'l | MQ1 | NA |
| | NRC-4-wire 64kbps(COC)interface card -1st | 1D1DD | NA |
| | NRC-4-wire 64kbps(COC)interface card -Add'l | 1D1DD | NA |
| | NRC-DS1 interoffice channel and 4-wire 64kbps Local Loop Combination - E | SOMEK | NA |
| | NRC-DS1 interoffice channel and 4-wire 64kbps Local Loop Combination - M | SOMAN | NA |
| | NRC-DS1 interoffice channel and 4-wire 64kbps Local Loop Combination - M | SOMAN | NA |
| | NRC-DS1 interoffice channel and 4-wire 64kbps Local Loop Combination - M | SOMAN | NA |
| | NRC-DS1 interoffice channel and 4-wire 64kbps Local Loop Combination - M | SOMAN | NA |
| | NRC-DS1 interoffice channel and 4-wire 64kbps Local Loop Combination - M | SOMAN | NA |
| DS1 Interoffice Channel and DS1 Interoffice Local Loop: | | | |
| Recurring Charges | | | |
| | DS1 Loop per month, State wide | USLXX | NA |
| | DS1 Loop per month, Zone 1 (Note 1) | TBD | NA |
| | DS1 Loop per month, Zone 2 (Note 1) | TBD | NA |
| | DS1 Loop per month, Zone 3 (Note 1) | TBD | NA |
| | DS1 Loop per month, Zone 4 (Note 1) | NA | NA |
| | Interoffice Channel - Dedicated - DS1 - per mile per month | 1L5XX | NA |
| | Interoffice Channel - Dedicated - DS1 - Facility Termination per month | U1TF1 | NA |
| Non-Recurring Charges - New EEL (Note 2) (Note 3) | | | |
| | NRC- DS1 interoffice - 1st | U1TF1 | NA |
| | NRC- DS1 interoffice - Add'l | U1TF1 | NA |
| | NRC-DS1 Local Loop - 1st | USLXX | NA |
| | NRC-DS1 Local Loop - Add'l | USLXX | NA |
| | NRC-DS1 interoffice channel and DS1 Local Loop Combination - Electronic Svc | SOMEK | NA |
| | NRC-DS1 interoffice channel and DS1 Local Loop Combination - Manual Svc | SOMAN | NA |
| | NRC-DS1 interoffice channel and DS1 Local Loop Combination - Manual Svc | SOMAN | NA |
| | NRC-DS1 interoffice channel and DS1 Local Loop Combination - Manual Svc | SOMAN | NA |
| | NRC-DS1 interoffice channel and DS1 Local Loop Combination - Manual Svc | SOMAN | NA |
| | NRC-DS1 interoffice channel and DS1 Local Loop Combination - Manual Svc | SOMAN | NA |

BELLSOUTH/ADELPHIA RATES
NETWORK ELEMENTS
AND OTHER SERVICES

| ENHANCED EXTENDED LINKS (EELs) | | | |
|--------------------------------|--|--------|----|
| | New EEL rates are the sum of the individual UNE network elements (interoffice transport and loop [channelization if applicable]. | | |
| | | USOC | KY |
| | DS3 Interoffice Channel and DS3 Local Loop: | | |
| | Recurring Charges | | |
| | DS3 Loop per Facility Termination per month | UE3PX | NA |
| | DS3 Loop per mile | 1L5ND | NA |
| | Interoffice Channel - Dedicated - DS3 - Facility Termination per month | 1L5XX | NA |
| | Interoffice Channel - Dedicated - DS3 - per mile per month | U1TF3 | NA |
| | Non-Recurring Charges - New EEL (Note 2)(Note 3) | | |
| | NRC- DS3 interoffice - 1st | U1TF3 | NA |
| | NRC- DS3 interoffice - Add'l | U1TF3 | NA |
| | NRC-DS3 Local Loop - 1st | UE3PX | NA |
| | NRC-DS3 Local Loop - Add'l | UE3PX | NA |
| | NRC-DS3 interoffice channel and DS3 Local Loop Combination - Electronic Svc | SOMECS | NA |
| | NRC-DS3 interoffice channel and DS3 Local Loop Combination - Manual Svc | SOMAN | NA |
| | NRC-DS3 interoffice channel and DS3 Local Loop Combination - Manual Svc | SOMAN | NA |
| | NRC-DS3 interoffice channel and DS3 Local Loop Combination - Manual Svc | SOMAN | NA |
| | NRC-DS3 interoffice channel and DS3 Local Loop Combination - Manual Svc | SOMAN | NA |
| | NRC-DS3 interoffice channel and DS3 Local Loop Combination - Manual Svc | SOMAN | NA |
| | STS-1 Interoffice Channel and STS-1 Local Loop: | | |
| | Recurring Charges | | |
| | STS-1 Loop per Facility Termination per month | UDLS1 | NA |
| | STS-1 Loop per mile | 1L5ND | NA |
| | Interoffice Channel - Dedicated - STS-1 - Facility Termination per month | U1TFS | NA |
| | Interoffice Channel - Dedicated - STS-1 - per mile per month | 1L5XX | NA |
| | Non-Recurring Charges - New EEL (Note 2)(Note 3) | | |
| | NRC- STS-1 interoffice - 1st | U1TFS | NA |
| | NRC- STS-1 interoffice - Add'l | U1TFS | NA |
| | NRC-STS-1 Local Loop - 1st | UDLS1 | NA |
| | NRC-STS-1 Local Loop - Add'l | UDLS1 | NA |
| | NRC-STS-1 interoffice channel and STS-1 Local Loop Combination - Electronic Svc | SOMECS | NA |
| | NRC-STS-1 interoffice channel and STS-1 Local Loop Combination - Manual Svc | SOMAN | NA |
| | NRC-STS-1 interoffice channel and STS-1 Local Loop Combination - Manual Svc | SOMAN | NA |
| | NRC-STS-1 interoffice channel and STS-1 Local Loop Combination - Manual Svc | SOMAN | NA |
| | NRC-STS-1 interoffice channel and STS-1 Local Loop Combination - Manual Svc | SOMAN | NA |
| | NRC-STS-1 interoffice channel and STS-1 Local Loop Combination - Manual Svc | SOMAN | NA |
| | DS3 Interoffice Channel and DS1 Local Loop: | | |
| | Recurring Charges | | |
| | DS1 Loop per month, State wide | USLXX | NA |
| | DS1 Loop per month, Zone 1 (Note 1) | TBD | NA |
| | DS1 Loop per month, Zone 2 (Note 1) | TBD | NA |
| | DS1 Loop per month, Zone 3 (Note 1) | TBD | NA |
| | DS1 Loop per month, Zone 4 (Note 1) | NA | NA |
| | Interoffice Channel - Dedicated - DS3 - Facility Termination per month | U1TF3 | NA |
| | Interoffice Channel - Dedicated - DS3 - per mile per month | 1L5XX | NA |
| | DS3 Channelized System per month | MQ3 | NA |
| | DS3 Interface per month (DS1 COCI) | UC1D1 | NA |
| | Non-Recurring Charges - New EEL (Note 2)(Note 3) | | |
| | NRC- DS3 interoffice - 1st | U1TF3 | NA |
| | NRC- DS3 interoffice - Add'l | U1TF3 | NA |
| | NRC-DS1 Local Loop - 1st | USLXX | NA |
| | NRC-DS1 Local Loop - Add'l | USLXX | NA |

BELLSOUTH/ADELPHIA RATES
NETWORK ELEMENTS
AND OTHER SERVICES

| ENHANCED EXTENDED LINKS (EELs) | | | |
|---------------------------------------|---|-------------|-----------|
| | New EEL rates are the sum of the individual UNE network elements (interoffice transport and loop [channelization if applicable]. | | |
| | | USOC | KY |
| | NRC-DS3 Channelization System -1st | MQ3 | NA |
| | NRC-DS3 Channelization System - Add'l | MQ3 | NA |
| | NRC-DS1(COCL)interface card -1st | UC1D1 | NA |
| | NRC-DS1(COCL)interface card -Add'l | UC1D1 | NA |
| | NRC-DS3 interoffice channel and DS1 Local Loop Combination - Electronic S | SOMEK | NA |
| | NRC-DS3 interoffice channel and DS1 Local Loop Combination - Manual Svc | SOMAN | NA |
| | NRC-DS3 interoffice channel and DS1 Local Loop Combination - Manual Svc | SOMAN | NA |
| | NRC-DS3 interoffice channel and DS1 Local Loop Combination - Manual Svc | SOMAN | NA |
| | NRC-DS3 interoffice channel and DS1 Local Loop Combination - Manual Svc | SOMAN | NA |
| | NRC-DS3 interoffice channel and DS1 Local Loop Combination - Manual Svc | SOMAN | NA |
| | STS-1 Interoffice Channel and DS1 Local Loop: | | |
| | Recurring Charges | | |
| | DS1 Loop per month, State wide | USLXX | NA |
| | DS1 Loop per month, Zone 1 (Note 1) | TBD | NA |
| | DS1 Loop per month, Zone 2 (Note 1) | TBD | NA |
| | DS1 Loop per month, Zone 3 (Note 1) | TBD | NA |
| | DS1 Loop per month, Zone 4 (Note 1) | NA | NA |
| | Interoffice Channel - Dedicated - STS-1 - Facility Termination per month | U1TFS | NA |
| | Interoffice Channel - Dedicated - STS-1 - per mile per month | 1L5XX | NA |
| | DS3 Channelized System per month | MQ3 | NA |
| | DS3 Interface per month (DS1 COCL) | UC1D1 | NA |
| | Non-Recurring Charges - New EEL (Note 2)(Note 3) | | |
| | NRC-DS1 Local Loop - 1st | USLXX | NA |
| | NRC-DS1 Local Loop - Add'l | USLXX | NA |
| | NRC- STS-1 interoffice - 1st | U1TFS | NA |
| | NRC- STS-1 interoffice - Add'l | U1TFS | NA |
| | NRC-DS3 Channelization System -1st | MQ3 | NA |
| | NRC-DS3 Channelization System - Add'l | MQ3 | NA |
| | NRC-DS1(COCL)interface card -1st | UC1D1 | NA |
| | NRC-DS1(COCL)interface card -Add'l | UC1D1 | NA |
| | NRC-STS-1 interoffice channel and DS1 Local Loop Combination - Electronic S | SOMEK | NA |
| | NRC-STS-1 interoffice channel and DS1 Local Loop Combination - Manual S | SOMAN | NA |
| | NRC-STS-1 interoffice channel and DS1 Local Loop Combination - Manual S | SOMAN | NA |
| | NRC-STS-1 interoffice channel and DS1 Local Loop Combination - Manual S | SOMAN | NA |
| | NRC-STS-1 interoffice channel and DS1 Local Loop Combination - Manual S | SOMAN | NA |
| | NRC-STS-1 interoffice channel and DS1 Local Loop Combination - Manual S | SOMAN | NA |
| | 2-wire VG Interoffice Channel and 2-wire VG Local Loop: | | |
| | Recurring Charges | | |
| | 2-wire VG Loop per month, statewide | UEAL2 | NA |
| | 2-wire VG Loop per month, Zone 1 (Note 1) | TBD | NA |
| | 2-wire VG Loop per month, Zone 2 (Note 1) | TBD | NA |
| | 2-wire VG Loop per month, Zone 3 (Note 1) | TBD | NA |
| | 2-wire VG Loop per month, Zone 4 (Note 1) | NA | NA |
| | Interoffice Channel - Dedicated - 2-wire VG - Facility Termination per month | U1TV2 | NA |
| | Interoffice Channel - Dedicated - 2-wire VG - per mile per month | 1L5XX | NA |
| | Non-Recurring Charges - New EEL (Note 2)(Note 3) | | |
| | NRC- 2-wire VG interoffice - 1st | U1TV2 | NA |
| | NRC- 2-wire VG interoffice - Add'l | U1TV2 | NA |
| | NRC-2-wire VG Local Loop - 1st | UEAL2 | NA |
| | NRC-2-wire VG Local Loop - Add'l | UEAL2 | NA |

BELLSOUTH/ADELPHIA RATES
NETWORK ELEMENTS
AND OTHER SERVICES

| ENHANCED EXTENDED LINKS (EELs) | | | |
|--------------------------------|--|-------|----|
| | New EEL rates are the sum of the individual UNE network elements (interoffice transport and loop [channelization if applicable]. | | |
| | | USOC | KY |
| | NRC-2-wire VG interoffice channel and 2-wire VG Local Loop Combination - E | SOMEK | NA |
| | NRC-2-wire VG interoffice channel and 2-wire VG Local Loop Combination - M | SOMAN | NA |
| | NRC-2-wire VG interoffice channel and 2-wire VG Local Loop Combination - M | SOMAN | NA |
| | NRC-2-wire VG interoffice channel and 2-wire VG Local Loop Combination - M | SOMAN | NA |
| | NRC-2-wire VG interoffice channel and 2-wire VG Local Loop Combination - M | SOMAN | NA |
| | NRC-2-wire VG interoffice channel and 2-wire VG Local Loop Combination - M | SOMAN | NA |
| | 4-wire VG Interoffice Channel and 4-wire VG Local Loop: | | |
| | Recurring Charges | | |
| | 4-wire VG Loop per month, statewide | UEAL4 | NA |
| | 4-wire VG Loop per month, Zone 1 (Note 1) | TBD | NA |
| | 4-wire VG Loop per month, Zone 2 (Note 1) | TBD | NA |
| | 4-wire VG Loop per month, Zone 3 (Note 1) | TBD | NA |
| | 4-wire VG Loop per month, Zone 4 (Note 1) | NA | NA |
| | Interoffice Channel - Dedicated - 4-wire VG - FacilityTermination per month | U1TV4 | NA |
| | Interoffice Channel - Dedicated - 4-wire VG - per mile per month | 1L5XX | NA |
| | Non-Recurring Charges - New EEL (Note 2)(Note 3) | | |
| | NRC- 4-wire VG interoffice - 1st | U1TV4 | NA |
| | NRC- 4-wire VG interoffice - Add'l | U1TV4 | NA |
| | NRC-4-wire VG Local Loop - 1st | UEAL4 | NA |
| | NRC-4-wire VG Local Loop - Add'l | UEAL4 | NA |
| | NRC-4-wire VG interoffice channel and 4-wire VG Local Loop Combination - E | SOMEK | NA |
| | NRC-4-wire VG interoffice channel and 4-wire VG Local Loop Combination - M | SOMAN | NA |
| | NRC-4-wire VG interoffice channel and 4-wire VG Local Loop Combination - M | SOMAN | NA |
| | NRC-4-wire VG interoffice channel and 4-wire VG Local Loop Combination - M | SOMAN | NA |
| | NRC-4-wire VG interoffice channel and 4-wire VG Local Loop Combination - M | SOMAN | NA |
| | NRC-4-wire VG interoffice channel and 4-wire VG Local Loop Combination - M | SOMAN | NA |
| | 4-wire 56 kbps Interoffice Channel and 4-wire 56kbps Local Loop: | | |
| | Recurring Charges | | |
| | 4-wire 56kbps Loop per month, statewide | UDL56 | NA |
| | 4-wire 56kbps Loop per month, Zone 1 (Note 1) | TBD | NA |
| | 4-wire 56kbps Loop per month, Zone 2 (Note 1) | TBD | NA |
| | 4-wire 56kbps Loop per month, Zone 3 (Note 1) | TBD | NA |
| | 4-wire 56kbps Loop per month, Zone 4 (Note 1) | NA | NA |
| | Interoffice Channel - Dedicated - 4-wire 56kbps - FacilityTermination per month | U1TD5 | NA |
| | Interoffice Channel - Dedicated - 4-wire 56kbps - per mile per month | 1L5XX | NA |
| | Non-Recurring Charges - New EEL (Note 2)(Note 3) | | |
| | NRC- 4-wire 56kbps interoffice - 1st | U1TD6 | NA |
| | NRC- 4-wire 56kbps interoffice - Add'l | U1TD6 | NA |
| | NRC-4-wire 56kbps Local Loop - 1st | U1TD5 | NA |
| | NRC-4-wire 56kbps Local Loop - Add'l | U1TD5 | NA |
| | NRC-4-wire 56kbps interoffice channel and 4-wire 56kbps Local Loop Comb | SOMEK | NA |
| | NRC-4-wire 56kbps interoffice channel and 4-wire 56kbps Local Loop Comb | SOMAN | NA |
| | NRC-4-wire 56kbps interoffice channel and 4-wire 56kbps Local Loop Comb | SOMAN | NA |
| | NRC-4-wire 56kbps interoffice channel and 4-wire 56kbps Local Loop Comb | SOMAN | NA |
| | NRC-4-wire 56kbps interoffice channel and 4-wire 56kbps Local Loop Comb | SOMAN | NA |
| | NRC-4-wire 56kbps interoffice channel and 4-wire 56kbps Local Loop Comb | SOMAN | NA |
| | 4-wire 64 kbps Interoffice Channel and 4-wire 64 kbps Local Loop: | | |
| | Recurring Charges | | |
| | 4-wire 64kbps Loop per month, statewide | UDL64 | NA |

BELLSOUTH/ADELPHIA RATES
NETWORK ELEMENTS
AND OTHER SERVICES

| ENHANCED EXTENDED LINKS (EELs) | | | |
|--------------------------------|--|-------|---------|
| | New EEL rates are the sum of the individual UNE network elements (interoffice transport and loop [channelization if applicable]. | | |
| | | USOC | KY |
| | 4-wire 64kbps Loop per month, Zone 1 (Note 1) | TBD | NA |
| | 4-wire 64kbps Loop per month, Zone 2 (Note 1) | TBD | NA |
| | 4-wire 64kbps Loop per month, Zone 3 (Note 1) | TBD | NA |
| | 4-wire 64kbps Loop per month, Zone 4 (Note 1) | NA | NA |
| | Interoffice Channel - Dedicated - 4-wire 64kbps - Facility Termination per month | U1TD6 | NA |
| | Interoffice Channel - Dedicated - 4-wire 64kbps - per mile per month | 1L5XX | NA |
| | Non-Recurring Charges - New EEL (Note 2)(Note 3) | | |
| | NRC- 4-wire 64kbps interoffice - 1st | U1TD6 | NA |
| | NRC- 4-wire 64kbps interoffice - Add'l | U1TD6 | NA |
| | NRC-4-wire 64kbps Local Loop - 1st | UDL64 | NA |
| | NRC-4-wire 64kbps Local Loop - Add'l | UDL64 | NA |
| | NRC-4-wire 64kbps interoffice channel and 4-wire 64kbps Local Loop Combination | SOMEK | NA |
| | NRC-4-wire 64kbps interoffice channel and 4-wire 64kbps Local Loop Combination | SOMAN | NA |
| | NRC-4-wire 64kbps interoffice channel and 4-wire 64kbps Local Loop Combination | SOMAN | NA |
| | NRC-4-wire 64kbps interoffice channel and 4-wire 64kbps Local Loop Combination | SOMAN | NA |
| | NRC-4-wire 64kbps interoffice channel and 4-wire 64kbps Local Loop Combination | SOMAN | NA |
| | NRC-4-wire 64kbps interoffice channel and 4-wire 64kbps Local Loop Combination | SOMAN | NA |
| | | USOC | KY |
| | Local Loop: | | |
| | 2-Wire Analog Voice Grade Loop - Service Level 1 | UEAL2 | \$20.00 |
| | Zone 1 | TBD | \$14.79 |
| | Zone 2 | TBD | \$27.68 |
| | Zone 3 | TBD | \$47.78 |
| | Zone 4 | TBD | NA |
| | NRC - Ordinarily Combined in GA (Note 5) | | |
| | NRC - 1st | UEAL2 | NA |
| | NRC - Add'l | UEAL2 | NA |
| | NRC - Disconnect Charge - 1st | UEAL2 | NA |
| | NRC - Disconnect Charge - Add'l | UEAL2 | NA |
| | NRC - Electronic Svc Order, per LSR | SOMEK | NA |
| | NRC - Incremental Charge - Manual Service Order - 1st | SOMAN | NA |
| | NRC - Incremental Charge - Manual Service Order - Add'l | SOMAN | NA |
| | NRC - Incremental Charge - Manual Service Order - Disconnect | SOMAN | NA |
| | NRC-All Existing Combination "Switch As Is" Conversion Charge (Note 6) | | |
| | NRC-2/4-WIRE VG COMBINATION - "Switch As Is" Conversion Charge - 1st | UNCCC | \$54.09 |
| | NRC-2/4-WIRE VG COMBINATION - "Switch As Is" Conversion Charge - Add'l | UNCCC | \$32.16 |
| | NRC- 2/4-WIRE VG COMBINATION - "Switch As Is" Conversion Charge - Disconnect | UNCCC | \$0.00 |
| | NRC- 2/4-WIRE VG COMBINATION - "Switch As Is" Conversion Charge - Disconnect | UNCCC | \$0.00 |
| | | | |
| | 4-Wire Analog Voice Grade Loop | | |
| | Zone 1 | UEAL4 | \$28.28 |
| | Zone 2 | TBD | \$20.92 |
| | Zone 3 | TBD | \$39.14 |
| | Zone 4 | TBD | \$67.56 |
| | Zone 4 | TBD | NA |
| | NRC - Ordinarily Combined in GA (Note 5) | | |
| | NRC - 1st | UEAL4 | NA |
| | NRC - Add'l | UEAL4 | NA |
| | NRC - Disconnect Charge - 1st | UEAL4 | NA |
| | NRC - Disconnect Charge - Add'l | UEAL4 | NA |
| | NRC - Electronic Svc Order, per LSR | SOMEK | NA |
| | NRC - Incremental Charge - Manual Service Order - 1st | SOMAN | NA |

BELLSOUTH/ADELPHIA RATES
NETWORK ELEMENTS
AND OTHER SERVICES

| ENHANCED EXTENDED LINKS (EELs) | | | |
|--------------------------------|---|-------|---------|
| | New EEL rates are the sum of the individual UNE network elements (interoffice transport and loop [channelization if applicable]). | | |
| | | USOC | KY |
| | NRC - Incremental Charge - Manual Service Order - Add'l | SOMAN | NA |
| | NRC - Incremental Charge - Manual Service Order - Disconnect | SOMAN | NA |
| | NRC-All Existing Combination "Switch As Is" Conversion Charge (Note 6) | | |
| | NRC-2/4-WIRE VG COMBINATION - "Switch As Is" Conversion Charge - 1st | UNCCC | \$54.09 |
| | NRC-2/4-WIRE VG COMBINATION - "Switch As Is" Conversion Charge - Ad | UNCCC | \$32.16 |
| | NRC- 2/4-WIRE VG COMBINATION - "Switch As Is" Conversion Charge - Di | UNCCC | \$0.00 |
| | NRC- 2/4-WIRE VG COMBINATION - "Switch As Is" Conversion Charge - Di | UNCCC | \$0.00 |
| | 2-Wire ISDN Digital Grade Loop | | |
| | Zone 1 | U1L2X | \$31.99 |
| | Zone 2 | TBD | \$23.66 |
| | Zone 3 | TBD | \$44.28 |
| | Zone 4 | TBD | \$76.42 |
| | NRC - Ordinarily Combined in GA (Note 5) | | |
| | NRC - 1st | U1L2X | NA |
| | NRC - Add'l | U1L2X | NA |
| | NRC - Disconnect Dcharge - 1st | U1L2X | NA |
| | NRC - Disconnect Charge - Add'l | U1L2X | NA |
| | NRC - Electronic Svc Order, per LSR | SOMEK | NA |
| | NRC - Incremental Charge - Manual Service Order - 1st | SOMAN | NA |
| | NRC - Incremental Charge - Manual Service Order - Add'l | SOMAN | NA |
| | NRC - Incremental Charge - Manual Service Order - Disconnect | SOMAN | NA |
| | NRC-All Existing Combination "Switch As Is" Conversion Charge (Note 6) | | |
| | NRC-2/4-WIRE VG COMBINATION - "Switch As Is" Conversion Charge - 1st | UNCCC | \$54.09 |
| | NRC-2/4-WIRE VG COMBINATION - "Switch As Is" Conversion Charge - Ad | UNCCC | \$32.16 |
| | NRC- 2/4-WIRE VG COMBINATION - "Switch As Is" Conversion Charge - Di | UNCCC | \$0.00 |
| | NRC- 2/4-WIRE VG COMBINATION - "Switch As Is" Conversion Charge - Di | UNCCC | \$0.00 |
| | 4-Wire 56 kbps Digital Grade Loop | | |
| | Zone 1 | UDL56 | NA |
| | Zone 2 | TBD | NA |
| | Zone 3 | TBD | NA |
| | Zone 4 | TBD | NA |
| | NRC - Ordinarily Combined in GA (Note 5) | | |
| | NRC - 1st | UDL56 | NA |
| | NRC - Add'l | UDL56 | NA |
| | NRC - Disconnect Dcharge - 1st | UDL56 | NA |
| | NRC - Disconnect Charge - Add'l | UDL56 | NA |
| | NRC - Electronic Svc Order, per LSR | SOMEK | NA |
| | NRC - Incremental Charge - Manual Service Order - 1st | SOMAN | NA |
| | NRC - Incremental Charge - Manual Service Order - Add'l | SOMAN | NA |
| | NRC - Incremental Charge - Manual Service Order - Disconnect | SOMAN | NA |
| | NRC-All Existing Combination "Switch As Is" Conversion Charge (Note 6) | | |
| | NRC-2/4-WIRE VG COMBINATION - "Switch As Is" Conversion Charge - 1st | UNCCC | \$54.09 |
| | NRC-2/4-WIRE VG COMBINATION - "Switch As Is" Conversion Charge - Ad | UNCCC | \$32.16 |
| | NRC- 2/4-WIRE VG COMBINATION - "Switch As Is" Conversion Charge - Di | UNCCC | \$0.00 |
| | NRC- 2/4-WIRE VG COMBINATION - "Switch As Is" Conversion Charge - Di | UNCCC | \$0.00 |
| | 4-Wire 64 kbps Digital Grade Loop | | |
| | Zone 1 | UDL64 | NA |
| | Zone 2 | TBD | NA |
| | Zone 3 | TBD | NA |

BELLSOUTH/ADELPHIA RATES
NETWORK ELEMENTS
AND OTHER SERVICES

| ENHANCED EXTENDED LINKS (EELs) | | | |
|---------------------------------------|--|-------------|-----------|
| | New EEL rates are the sum of the individual UNE network elements (interoffice transport and loop [channelization if applicable]. | | |
| | | USOC | KY |
| | Zone 4 | TBD | NA |
| | NRC - Ordinarily Combined in GA (Note 5) | | |
| | NRC - 1st | UDL64 | NA |
| | NRC - Add'l | UDL64 | NA |
| | NRC - Disconnect Dcharge - 1st | UDL64 | NA |
| | NRC - Disconnect Charge - Add'l | UDL64 | NA |
| | NRC - Electronic Svc Order, per LSR | SOMEK | NA |
| | NRC - Incremental Charge - Manual Service Order - 1st | SOMAN | NA |
| | NRC - Incremental Charge - Manual Service Order - Add'l | SOMAN | NA |
| | NRC - Incremental Charge - Manual Service Order - Disconnect | SOMAN | NA |
| | NRC-All Existing Combination "Switch As Is" Conversion Charge (Note 6) | | |
| | NRC-2/4-WIRE VG COMBINATION - "Switch As Is" Conversion Charge - 1st | UNCCC | \$54.09 |
| | NRC-2/4-WIRE VG COMBINATION - "Switch As Is" Conversion Charge - Add'l | UNCCC | \$32.16 |
| | NRC- 2/4-WIRE VG COMBINATION - "Switch As Is" Conversion Charge - Disconnect | UNCCC | \$0.00 |
| | NRC- 2/4-WIRE VG COMBINATION - "Switch As Is" Conversion Charge - Disconnect | UNCCC | \$0.00 |
| | 4-Wire DS1 Digital Loop | | |
| | | USLXX | \$67.96 |
| | Zone 1 | TBD | \$50.28 |
| | Zone 2 | TBD | \$94.06 |
| | Zone 3 | TBD | \$162.34 |
| | Zone 4 | TBD | NA |
| | NRC - Ordinarily Combined in GA (Note 5) | | |
| | NRC - 1st | USLXX | NA |
| | NRC - Add'l | USLXX | NA |
| | NRC - Disconnect Charge - 1st | USLXX | NA |
| | NRC - Disconnect Charge - Add'l | USLXX | NA |
| | NRC - Electronic Svc Order, per LSR | SOMEK | NA |
| | NRC - Incremental Charge - Manual Service Order - 1st | SOMAN | NA |
| | NRC - Incremental Charge - Manual Service Order - Add'l | SOMAN | NA |
| | NRC - Incremental Charge - Manual Service Order - Disconnect | SOMAN | NA |
| | NRC-All Existing Combination "Switch As Is" Conversion Charge (Note 6) | | |
| | NRC-2/4-WIRE VG COMBINATION - "Switch As Is" Conversion Charge - 1st | UNCCC | \$54.09 |
| | NRC-2/4-WIRE VG COMBINATION - "Switch As Is" Conversion Charge - Add'l | UNCCC | \$32.16 |
| | NRC- 2/4-WIRE VG COMBINATION - "Switch As Is" Conversion Charge - Disconnect | UNCCC | \$0.00 |
| | NRC- 2/4-WIRE VG COMBINATION - "Switch As Is" Conversion Charge - Disconnect | UNCCC | \$0.00 |
| | DS3 Loop | | |
| | per mile per month | 1L5ND | \$43.69 |
| | facility termination per month | UE3PX | \$436.95 |
| | NRC - Ordinarily Combined in GA (Note 5) | | |
| | NRC - Facility Termination - 1st | UE3PX | NA |
| | NRC - Facility Termination - Add'l | UE3PX | NA |
| | NRC - Facility Termination - Disconnect - 1st | UE3PX | NA |
| | NRC - Facility Termination - Disconnect - Add'l | UE3PX | NA |
| | NRC - Manual Svc Order, per LSR | SOMAN | NA |
| | NRC - Manual Svc Order, per LSR disconnect | SOMAN | NA |
| | NRC - Electronic Svc Order, per LSR | SOMEK | NA |
| | NRC - Electronic Svc Order, per LSR disconnect | SOMEK | NA |
| | NRC - Incremental Charge-Manual Svc Order - 1st | SOMAN | NA |
| | NRC - Incremental Charge-Manual Svc Order - Add'l | SOMAN | NA |
| | NRC - Incremental Cost - Manual Svc. Order vs. Elect-Disconnect-1st | SOMAN | NA |
| | NRC - Incremental Cost - Manual Svc. Order vs. Elect-Disconnect-Add'l | SOMAN | NA |

BELLSOUTH/ADELPHIA RATES
NETWORK ELEMENTS
AND OTHER SERVICES

| ENHANCED EXTENDED LINKS (EELs) | | | |
|--------------------------------|--|-------|----------|
| | New EEL rates are the sum of the individual UNE network elements (interoffice transport and loop [channelization if applicable]. | | |
| | | USOC | KY |
| | NRC-All Existing Combination "Switch As Is" Conversion Charge (Note 6) | | |
| | NRC-2/4-WIRE VG COMBINATION - "Switch As Is" Conversion Charge - 1st | UNCCC | \$54.09 |
| | NRC-2/4-WIRE VG COMBINATION - "Switch As Is" Conversion Charge - Ad | UNCCC | \$32.16 |
| | NRC- 2/4-WIRE VG COMBINATION - "Switch As Is" Conversion Charge - Di | UNCCC | \$0.00 |
| | NRC- 2/4-WIRE VG COMBINATION - "Switch As Is" Conversion Charge - Di | UNCCC | \$0.00 |
| | STS-1 Loop | | |
| | per mile per month | 1L5ND | \$43.69 |
| | facility termination per month | UDLS1 | \$436.95 |
| | NRC - Ordinarily Combined in GA (Note 5) | | |
| | NRC - STS-1 - Facility Termination - 1st | UDLS1 | NA |
| | NRC - STS-1 - Facility Termination - Add'l | UDLS1 | NA |
| | NRC - STS-1 - Facility Termination - Disconnect - 1st | UDLS1 | NA |
| | NRC - STS-1 - Facility Termination - Disconnect - Add'l | UDLS1 | NA |
| | NRC - Manual Svc Order, per LSR | SOMAN | NA |
| | NRC - Manual Svc Order, per LSR disconnect | SOMAN | NA |
| | NRC - Electronic Svc Order, per LSR | SOMEK | NA |
| | NRC - Electronic Svc Order, per LSR disconnect | SOMEK | NA |
| | NRC - STS-1 - Incremental Charge--Manual Svc Order - 1st | SOMAN | NA |
| | NRC - STS-1 - Incremental Charge--Manual Svc Order - Add'l | SOMAN | NA |
| | NRC - STS-1 - Incremental Cost - Manual Svc. Order vs. Elect-Discon | SOMAN | NA |
| | NRC - STS-1 - Incremental Cost - Manual Svc. Order vs. Elect-Discon | SOMAN | NA |
| | NRC-All Existing Combination "Switch As Is" Conversion Charge (Note 6) | | |
| | NRC-2/4-WIRE VG COMBINATION - "Switch As Is" Conversion Charge - 1st | UNCCC | \$54.09 |
| | NRC-2/4-WIRE VG COMBINATION - "Switch As Is" Conversion Charge - Ad | UNCCC | \$32.16 |
| | NRC- 2/4-WIRE VG COMBINATION - "Switch As Is" Conversion Charge - Di | UNCCC | \$0.00 |
| | NRC- 2/4-WIRE VG COMBINATION - "Switch As Is" Conversion Charge - Di | UNCCC | \$0.00 |
| | OC-3 Loop | | |
| | per mile per month | 1L5ND | \$33.15 |
| | facility termination per month | TBD | \$436.95 |
| | NRC - Ordinarily Combined in GA (Note 5) | | |
| | NRC - OC3 - Facility Termination - 1st | TBD | NA |
| | NRC - OC3 - Facility Termination - Add'l | TBD | NA |
| | NRC - OC3 - Facility Termination - Disconnect - 1st | TBD | NA |
| | NRC - OC3 - Facility Termination - Disconnect - Add'l | TBD | NA |
| | NRC - Electronic Svc Order, per LSR | SOMEK | NA |
| | NRC - OC3 - Incremental Charge--Manual Svc Order - 1st | SOMAN | NA |
| | NRC - OC3 - Incremental Charge--Manual Svc Order - Add'l | SOMAN | NA |
| | NRC - OC3 -Incremental Cost - Manual Svc. Order vs. Elect-Discon | SOMAN | NA |
| | NRC - OC3 -Incremental Cost - Manual Svc. Order vs. Elect-Discon | SOMAN | NA |
| | NRC-All Existing Combination "Switch As Is" Conversion Charge (Note 6) | | |
| | NRC-2/4-WIRE VG COMBINATION - "Switch As Is" Conversion Charge - 1st | UNCCC | \$54.09 |
| | NRC-2/4-WIRE VG COMBINATION - "Switch As Is" Conversion Charge - Ad | UNCCC | \$32.16 |
| | NRC- 2/4-WIRE VG COMBINATION - "Switch As Is" Conversion Charge - Di | UNCCC | \$0.00 |
| | NRC- 2/4-WIRE VG COMBINATION - "Switch As Is" Conversion Charge - Di | UNCCC | \$0.00 |
| | OC-12 Loop | | |
| | per mile per month | 1L5ND | \$40.80 |
| | facility termination per month | TBD | \$2,457 |
| | NRC - Ordinarily Combined in GA (Note 5) | | |
| | NRC - OC12 - Facility Termination - 1st | TBD | NA |

BELLSOUTH/ADELPHIA RATES
NETWORK ELEMENTS
AND OTHER SERVICES

| ENHANCED EXTENDED LINKS (EELs) | | | |
|--------------------------------|--|-------|----------|
| | New EEL rates are the sum of the individual UNE network elements (interoffice transport and loop [channelization if applicable]. | | |
| | | USOC | KY |
| | NRC - OC12 - Facility Termination - Add'l | TBD | NA |
| | NRC - OC12 - Facility Termination - Disconnect - 1st | TBD | NA |
| | NRC - OC12 - Facility Termination - Disconnect - Add'l | TBD | NA |
| | NRC - Electronic Svc Order, per LSR | SOMEK | NA |
| | NRC -OC12 - Incremental Charge - Manual Svc Order - 1st | SOMAN | NA |
| | NRC - OC12 - Incremental Charge - Manual Svc Order - Add'l | SOMAN | NA |
| | NRC - OC12 - Incremental Cost-Manual Svc. Order vs. Elect-Disconnec | SOMAN | NA |
| | NRC - OC12 - Incremental Cost-Manual Svc. Order vs. Elect-Disconnec | SOMAN | NA |
| | NRC-All Existing Combination "Switch As Is" Conversion Charge (Note 6) | | |
| | NRC-2/4-WIRE VG COMBINATION - "Switch As Is" Conversion Charge - 1st | UNCCC | \$54.09 |
| | NRC-2/4-WIRE VG COMBINATION - "Switch As Is" Conversion Charge - Ad | UNCCC | \$32.16 |
| | NRC- 2/4-WIRE VG COMBINATION - "Switch As Is" Conversion Charge - Di | UNCCC | \$0.00 |
| | NRC- 2/4-WIRE VG COMBINATION - "Switch As Is" Conversion Charge - Di | UNCCC | \$0.00 |
| | OC-48 Loop | | |
| | per mile per month | 1L5ND | \$166.59 |
| | facility termination per month | TBD | \$2,129 |
| | OC-12 Interface on OC-48 Loop per month | TBD | \$725.77 |
| | NRC - Ordinarily Combined in GA (Note 5) | | |
| | NRC - OC48 - Facility Termination - 1st | TBD | NA |
| | NRC - OC48 - Facility Termination - Add'l | TBD | NA |
| | NRC - OC48 - Interface OC12 on OC48 - 1st | TBD | NA |
| | NRC - OC48 - Interface OC12 on OC48 - Add'l | TBD | NA |
| | NRC - OC48 - Facility Termination - Disconnect - 1st | TBD | NA |
| | NRC - OC48 - Facility Termination - Disconnect - Add'l | TBD | NA |
| | NRC - OC48 - Interface OC12 on OC48 - Disconnect - 1st | TBD | NA |
| | NRC - OC48 - Interface OC12 on OC48 - Disconnect - Add'l | TBD | NA |
| | NRC - Electronic Svc Order, per LSR | SOMEK | NA |
| | NRC - OC48 - Facility Termination-Manual Svc Order vs Electronic-Disc | SOMAN | NA |
| | NRC - OC48 - Facility Termination-Manual Svc Order vs Electronic-Disc | SOMAN | NA |
| | NRC - OC48 - Interface - Manual Svc Order vs Electronic-Disconnect-1 | SOMAN | NA |
| | NRC - OC48 - Interface - Manual Svc Order vs Electronic-Disconnect-A | SOMAN | NA |
| | NRC - OC-48 - Incremental Charge--Manual Svc Order-1st | SOMAN | NA |
| | NRC - OC-48 - Incremental Charge--Manual Svc Order-Add'l | SOMAN | NA |
| | NRC - OC48 - Interface OC12 on OC48 - Incremental Charge--Manual | SOMAN | NA |
| | NRC - OC48 - Interface OC12 on OC48 - Incremental Charge--Manual | SOMAN | NA |
| | NRC-All Existing Combination "Switch As Is" Conversion Charge (Note 6) | | |
| | NRC-2/4-WIRE VG COMBINATION - "Switch As Is" Conversion Charge - 1st | UNCCC | \$54.09 |
| | NRC-2/4-WIRE VG COMBINATION - "Switch As Is" Conversion Charge - Ad | UNCCC | \$32.16 |
| | NRC- 2/4-WIRE VG COMBINATION - "Switch As Is" Conversion Charge - Di | UNCCC | \$0.00 |
| | NRC- 2/4-WIRE VG COMBINATION - "Switch As Is" Conversion Charge - Di | UNCCC | \$0.00 |
| | Local Channels: | | |
| | Local Channel - Dedicated - 2-Wire VG | | |
| | Monthly Recurring per month | ULDV2 | \$22.26 |
| | NRC - Ordinarily Combined in GA (Note 5) | | |
| | NRC - 2-wire VG Local Channel - 1st | ULDV2 | NA |
| | NRC - 2-wire VG Local Channel -Add'l | ULDV2 | NA |
| | NRC - Electronic Svc Order, per LSR | SOMEK | NA |
| | NRC - 2-Wire VG - Incremental Charge--Manual Svc Order - 1st | SOMAN | NA |
| | NRC - 2-Wire VG - Incremental Charge--Manual Svc Order - Add'l | SOMAN | NA |
| | NRC - 2-Wire VG - Incremental Charge--Manual Svc Order - Disconnect - 1st | SOMAN | NA |

BELLSOUTH/ADELPHIA RATES
NETWORK ELEMENTS
AND OTHER SERVICES

| ENHANCED EXTENDED LINKS (EELs) | | | |
|--------------------------------|--|-------|----------|
| | New EEL rates are the sum of the individual UNE network elements (interoffice transport and loop [channelization if applicable]. | | |
| | | USOC | KY |
| | NRC - 2-Wire VG - Incremental Charge--Manual Svc Order - Disconnect - Ad | SOMAN | NA |
| | NRC-All Existing Combination "Switch As Is" Conversion Charge (Note 6) | | |
| | NRC-2/4-WIRE VG COMBINATION - "Switch As Is" Conversion Charge - 1st | UNCCC | \$54.09 |
| | NRC-2/4-WIRE VG COMBINATION - "Switch As Is" Conversion Charge - Ad | UNCCC | \$32.16 |
| | NRC- 2/4-WIRE VG COMBINATION - "Switch As Is" Conversion Charge - Di | UNCCC | \$0.00 |
| | NRC- 2/4-WIRE VG COMBINATION - "Switch As Is" Conversion Charge - Di | UNCCC | \$0.00 |
| | Local Channel - Dedicated - 4-Wire VG | | |
| | Monthly Recurring per month | ULDV4 | \$23.38 |
| | NRC - Ordinarily Combined in GA (Note 5) | | |
| | NRC-4-wire VG Local Channel - 1st | ULDV4 | NA |
| | NRC-4-wire VG Local Channel - Add'l | ULDV4 | NA |
| | NRC - Electronic Svc Order, per LSR | SOMEK | NA |
| | NRC - 4-Wire VG Local Channel - Incremental Charge--Manual Svc Order - 1 | SOMAN | NA |
| | NRC - 4-Wire VG Local Channel - Incremental Charge--Manual Svc Order - A | SOMAN | NA |
| | NRC - 4-Wire VG Local Channel - Incremental Charge--Manual Svc Order - D | SOMAN | NA |
| | NRC - 4-Wire VG Local Channel - Incremental Charge--Manual Svc Order - D | SOMAN | NA |
| | NRC-All Existing Combination "Switch As Is" Conversion Charge (Note 6) | | |
| | NRC-2/4-WIRE VG COMBINATION - "Switch As Is" Conversion Charge - 1st | UNCCC | \$54.09 |
| | NRC-2/4-WIRE VG COMBINATION - "Switch As Is" Conversion Charge - Ad | UNCCC | \$32.16 |
| | NRC- 2/4-WIRE VG COMBINATION - "Switch As Is" Conversion Charge - Di | UNCCC | \$0.00 |
| | NRC- 2/4-WIRE VG COMBINATION - "Switch As Is" Conversion Charge - Di | UNCCC | \$0.00 |
| | Local Channel - Dedicated - DS1 | | |
| | DS1 Monthly Recurring per month | ULDF1 | \$43.80 |
| | NRC - Ordinarily Combined in GA (Note 5) | | |
| | NRC - DS1 Local Channel - 1st | ULDF1 | NA |
| | NRC - DS1 Local Channel - Add'l | ULDF1 | NA |
| | NRC - Electronic Svc Order, per LSR | SOMEK | NA |
| | NRC - DS1 Local Channel - Incremental Charge--Manual Svc Order - 1st | SOMAN | NA |
| | NRC - DS1 Local Channel - Incremental Charge--Manual Svc Order - Add'l | SOMAN | NA |
| | NRC - DS1 Local Channel - Incremental Charge--Manual Svc Order - Disconn | SOMAN | NA |
| | NRC - DS1 Local Channel - Incremental Charge--Manual Svc Order - Disconn | SOMAN | NA |
| | NRC-All Existing Combination "Switch As Is" Conversion Charge (Note 6) | | |
| | NRC-DS1 COMBINATION - "Switch As Is" Conversion Charge - 1st | UNCCC | \$54.09 |
| | NRC-DS1 COMBINATION - "Switch As Is" Conversion Charge - Add'l | UNCCC | \$32.16 |
| | NRC- DS1 COMBINATION - "Switch As Is" Conversion Charge - Disconnect | UNCCC | \$0.00 |
| | NRC- DS1 COMBINATION - "Switch As Is" Conversion Charge - Disconnect | UNCCC | \$0.00 |
| | Local Channel - Dedicated - DS3 | | |
| | DS3 Local Channel - per mile per month | 1L5NC | \$34.00 |
| | DS3 Local Channel - Facility Termination per month | ULDF3 | \$635.09 |
| | NRC - Ordinarily Combined in GA (Note 5) | | |
| | NRC - DS3 Local Channel Facility Termination - 1st | ULDF3 | NA |
| | NRC - DS3 Local Channel - Facility Termination - Add'l | ULDF3 | NA |
| | NRC - Electronic Svc Order, per LSR | SOMEK | NA |
| | NRC - DS3 Local Channel - Incremental Charge--Manual Svc Order - 1st | SOMAN | NA |
| | NRC - DS3 Local Channel - Incremental Charge--Manual Svc Order - Add'l | SOMAN | NA |
| | NRC - DS3 Local Channel - Incremental Charge--Manual Svc Order - Disconn | SOMAN | NA |
| | NRC - DS3 Local Channel - Incremental Charge--Manual Svc Order - Disconn | SOMAN | NA |
| | NRC-All Existing Combination "Switch As Is" Conversion Charge (Note 6) | | |
| | NRC-DS3 COMBINATION - "Switch As Is" Conversion Charge - 1st | UNCCC | \$54.09 |

BELLSOUTH/ADELPHIA RATES
NETWORK ELEMENTS
AND OTHER SERVICES

| ENHANCED EXTENDED LINKS (EELs) | | | |
|---------------------------------------|---|-------------|-----------|
| | New EEL rates are the sum of the individual UNE network elements (interoffice transport and loop [channelization if applicable]. | | |
| | | USOC | KY |
| | NRC-DS3 COMBINATION - "Switch As Is" Conversion Charge - Add'l | UNCCC | \$32.16 |
| | NRC- DS3 COMBINATION - "Switch As Is" Conversion Charge - Disconnect | UNCCC | \$0.00 |
| | NRC- DS3 COMBINATION - "Switch As Is" Conversion Charge - Disconnect | UNCCC | \$0.00 |
| | Local Channel - Dedicated - STS-1 | | |
| | STS-1 Local Channel - per mile per month | 1L5NC | \$34.00 |
| | STS-1 Local Channel - Facility Termination per month | ULDFS | \$635.09 |
| | NRC - Ordinarily Combined in GA (Note 5) | | |
| | NRC - STS-1 Local Channel Facility Termination - 1st | ULDFS | NA |
| | NRC - STS-1 Local Channel - Facility Termination - Add'l | ULDFS | NA |
| | NRC - Electronic Svc Order, per LSR | SOMEK | NA |
| | NRC - STS-1 Local Channel - Incremental Charge--Manual Svc Order - 1st | SOMAN | NA |
| | NRC - STS-1 Local Channel - Incremental Charge--Manual Svc Order - Add'l | SOMAN | NA |
| | NRC - STS-1 Local Channel - Incremental Charge--Manual Svc Order - Disc | SOMAN | NA |
| | NRC - STS-1 Local Channel - Incremental Charge--Manual Svc Order - Disc | SOMAN | NA |
| | NRC-All Existing Combination "Switch As Is" Conversion Charge (Note 6) | | |
| | NRC-STS-1 COMBINATION - "Switch As Is" Conversion Charge - 1st | UNCCC | \$54.09 |
| | NRC-STS-1 COMBINATION - "Switch As Is" Conversion Charge - Add'l | UNCCC | \$32.16 |
| | NRC- STS-1 COMBINATION - "Switch As Is" Conversion Charge - Disconnect | UNCCC | \$0.00 |
| | NRC- STS-1 COMBINATION - "Switch As Is" Conversion Charge - Disconnect | UNCCC | \$0.00 |
| | Local Channel - OC3 | | |
| | Local Channel - OC3 - per Mile | TBA | \$33.15 |
| | Local Channel - OC3 - per Facility Termination | TBA | \$713.29 |
| | NRC - Ordinarily Combined in GA (Note 5) | | |
| | NRC - OC3 - Facility Termination - 1st | TBA | NA |
| | NRC - OC3 - Facility Termination - Add'l | TBA | NA |
| | NRC - OC3 - Facility Termination - Disconnect - 1st | TBA | NA |
| | NRC - OC3 - Facility Termination - Disconnect - Add'l | TBA | NA |
| | NRC - Electronic Svc Order, per LSR | SOMEK | NA |
| | NRC - OC3 - Incremental Charge--Manual Svc Order - 1st | SOMAN | NA |
| | NRC - OC3 - Incremental Charge--Manual Svc Order - Add'l | SOMAN | NA |
| | NRC - OC3 -Incremental Cost - Manual Svc. Order vs. Elect-Disconnect-1st | SOMAN | NA |
| | NRC - OC3 -Incremental Cost - Manual Svc. Order vs. Elect-Disconnect-Add | SOMAN | NA |
| | NRC-All Existing Combination "Switch As Is" Conversion Charge (Note 6) | | |
| | NRC-OC-3 COMBINATION - "Switch As Is" Conversion Charge - 1st | UNCCC | \$54.09 |
| | NRC-OC-3 COMBINATION - "Switch As Is" Conversion Charge - Add'l | UNCCC | \$32.16 |
| | NRC- OC-3 COMBINATION - "Switch As Is" Conversion Charge - Disconnect | UNCCC | \$0.00 |
| | NRC- OC-3 COMBINATION - "Switch As Is" Conversion Charge - Disconnect | UNCCC | \$0.00 |
| | Local Channel - OC12 | USOC | KY |
| | Local Channel - OC12 - per Mile | TBA | \$40.80 |
| | Local Channel - OC12 - per Facility Termination | TBA | \$2,457 |
| | NRC - Ordinarily Combined in GA (Note 5) | | |
| | NRC - OC12 - Facility Termination - 1st | TBA | NA |
| | NRC - OC12 - Facility Termination - Add'l | TBA | NA |
| | NRC - OC12 - Facility Termination - Disconnect - 1st | TBA | NA |
| | NRC - OC12 - Facility Termination - Disconnect - Add'l | TBA | NA |
| | NRC - Electronic Svc Order, per LSR | SOMEK | NA |
| | NRC -OC12 - Incremental Charge - Manual Svc Order - 1st | SOMAN | NA |
| | NRC - OC12 - Incremental Charge - Manual Svc Order - Add'l | SOMAN | NA |
| | NRC - OC12 - Incremental Cost-Manual Svc. Order vs. Elect-Disconnect-1st | SOMAN | NA |

BELLSOUTH/ADELPHIA RATES
NETWORK ELEMENTS
AND OTHER SERVICES

| ENHANCED EXTENDED LINKS (EELs) | | | |
|---------------------------------------|---|-------------|-----------|
| | New EEL rates are the sum of the individual UNE network elements (interoffice transport and loop [channelization if applicable]. | | |
| | | USOC | KY |
| | NRC - OC12 - Incremental Cost-Manual Svc. Order vs. Elect-Disconnect-Add'l | SOMAN | NA |
| | NRC-All Existing Combination "Switch As Is" Conversion Charge (Note 6) | | |
| | NRC-OC-12 COMBINATION - "Switch As Is" Conversion Charge - 1st | UNCCC | \$54.09 |
| | NRC-OC-12 COMBINATION - "Switch As Is" Conversion Charge - Add'l | UNCCC | \$32.16 |
| | NRC- OC-12 COMBINATION - "Switch As Is" Conversion Charge - Disconnect | UNCCC | \$0.00 |
| | NRC- OC-12 COMBINATION - "Switch As Is" Conversion Charge - Disconnect | UNCCC | \$0.00 |
| | Local Channel - OC48 | USOC | KY |
| | Local Channel - OC48 - per Mile | TBA | \$133.84 |
| | Local Channel - OC48 - per Facility Termination | TBA | \$2,129 |
| | Local Channel - OC12 interface on OC48 Facility | TBA | \$725.77 |
| | NRC - Ordinarily Combined in GA (Note 5) | | |
| | NRC - OC48 - Facility Termination - 1st | TBA | NA |
| | NRC - OC48 - Facility Termination - Add'l | TBA | NA |
| | NRC - OC48 - Interface OC12 on OC48 - 1st | TBA | NA |
| | NRC - OC48 - Interface OC12 on OC48 - Add'l | TBA | NA |
| | NRC - OC48 - Facility Termination - Disconnect - 1st | TBA | NA |
| | NRC - OC48 - Facility Termination - Disconnect - Add'l | TBA | NA |
| | NRC - OC48- Interface OC12 on OC48 - Disconnect - 1st | TBA | NA |
| | NRC - OC48 - Interface OC12 on OC48 - Disconnect - Add'l | TBA | NA |
| | NRC - Electronic Svc Order, per LSR | SOMEK | NA |
| | NRC - OC48 - Facility Termination-Manual Svc Order vs Electronic-Disconnect | SOMAN | NA |
| | NRC - OC48 - Facility Termination-Manual Svc Order vs Electronic-Disconnect | SOMAN | NA |
| | NRC - OC48 - Interface - Manual Svc Order vs Electronic-Disconnect-1st | SOMAN | NA |
| | NRC - OC48 - Interface - Manual Svc Order vs Electronic-Disconnect-Add'l | SOMAN | NA |
| | NRC - OC-48 - Incremental Charge--Manual Svc Order-1st | SOMAN | NA |
| | NRC - OC-48 - Incremental Charge--Manual Svc Order-Add'l | SOMAN | NA |
| | NRC - OC48 - Interface OC12 on OC48 - Incremental Charge--Manual Svc Order | SOMAN | NA |
| | NRC - OC48 - Interface OC12 on OC48 - Incremental Charge--Manual Svc Order | SOMAN | NA |
| | NRC-All Existing Combination "Switch As Is" Conversion Charge (Note 6) | | |
| | NRC-OC-48 COMBINATION - "Switch As Is" Conversion Charge - 1st | UNCCC | \$54.09 |
| | NRC-OC-48 COMBINATION - "Switch As Is" Conversion Charge - Add'l | UNCCC | \$32.16 |
| | NRC- OC-48 COMBINATION - "Switch As Is" Conversion Charge - Disconnect | UNCCC | \$0.00 |
| | NRC- OC-48 COMBINATION - "Switch As Is" Conversion Charge - Disconnect | UNCCC | \$0.00 |
| | High Capacity Loops: | | |
| | Local Loop - Dedicated - DS3 | | |
| | DS3 Local Loop- per mile per month | 1L5ND | \$43.69 |
| | DS3 Local Loop- per Facility Termination | UE3PX | \$436.95 |
| | NRC - Ordinarily Combined in GA (Note 5) | | |
| | NRC - DS3 Local Channel - Facility Termination - 1st | UE3PX | NA |
| | NRC - DS3 Local Channel - Facility Termination - Add'l | UE3PX | NA |
| | NRC - Electronic Svc Order, per LSR | SOMEK | NA |
| | NRC - DS3 Local Channel - Incremental Charge--Manual Svc Order - 1st | SOMAN | NA |
| | NRC - DS3 Local Channel - Incremental Charge--Manual Svc Order - Add'l | SOMAN | NA |
| | NRC - DS3 Local Channel - Incremental Charge--Manual Svc Order - Disconnect | SOMAN | NA |
| | NRC - DS3 Local Channel - Incremental Charge--Manual Svc Order - Disconnect | SOMAN | NA |
| | NRC-All Existing Combination "Switch As Is" Conversion Charge (Note 6) | | |
| | NRC-DS3 COMBINATION - "Switch As Is" Conversion Charge - 1st | UNCCC | \$54.09 |
| | NRC-DS3 COMBINATION - "Switch As Is" Conversion Charge - Add'l | UNCCC | \$32.16 |
| | NRC- DS3 COMBINATION - "Switch As Is" Conversion Charge - Disconnect | UNCCC | \$0.00 |
| | NRC- DS3 COMBINATION - "Switch As Is" Conversion Charge - Disconnect | UNCCC | \$0.00 |

BELLSOUTH/ADELPHIA RATES
NETWORK ELEMENTS
AND OTHER SERVICES

| ENHANCED EXTENDED LINKS (EELs) | | | |
|---------------------------------------|--|-------------|-----------|
| | New EEL rates are the sum of the individual UNE network elements (interoffice transport and loop [channelization if applicable]. | | |
| | | USOC | KY |
| | Local Loop - Dedicated - STS-1 | | |
| | STS-1 Local Loop - per mile | 1L5ND | \$43.69 |
| | STS-1 Local Loop - per Facility Termination | UDLS1 | \$436.95 |
| | NRC - Ordinarily Combined in GA (Note 5) | | |
| | NRC - STS-1 Local Loop - Facility Termination - 1st | UDLS1 | NA |
| | NRC - STS-1 Local Loop - Facility Termination - Add'l | UDLS1 | NA |
| | NRC - Electronic Svc Order, per LSR | SOMEK | NA |
| | NRC - STS-1 Local Loop - Incremental Charge--Manual Svc Order - 1st | SOMAN | NA |
| | NRC - STS-1 Local Loop - Incremental Charge--Manual Svc Order - Add'l | SOMAN | NA |
| | NRC - STS-1 Local Loop - Incremental Charge--Manual Svc Order - Disconnect | SOMAN | NA |
| | NRC - STS-1 Local Loop - Incremental Charge--Manual Svc Order - Disconnect | SOMAN | NA |
| | NRC-All Existing Combination "Switch As Is" Conversion Charge (Note 6) | | |
| | NRC-ST-1 COMBINATION - "Switch As Is" Conversion Charge - 1st | UNCCC | \$54.09 |
| | NRC-ST-1 COMBINATION - "Switch As Is" Conversion Charge - Add'l | UNCCC | \$32.16 |
| | NRC - STS-1 COMBINATION - "Switch As Is" Conversion Charge - Disconnect | UNCCC | \$0.00 |
| | NRC - STS-1 COMBINATION - "Switch As Is" Conversion Charge - Disconnect | UNCCC | \$0.00 |
| | Local Loop - OC3 | | |
| | Local Loop - OC3 - per Mile | TBA | \$33.15 |
| | Local Loop - OC3 - per Facility Termination | TBA | \$713.29 |
| | NRC - Ordinarily Combined in GA (Note 5) | | |
| | NRC - OC3 - Facility Termination - 1st | TBA | NA |
| | NRC - OC3 - Facility Termination - Add'l | TBA | NA |
| | NRC - OC3 - Facility Termination - Disconnect - 1st | TBA | NA |
| | NRC - OC3 - Facility Termination - Disconnect - Add'l | TBA | NA |
| | NRC - Electronic Svc Order, per LSR | SOMEK | NA |
| | NRC - OC3 - Incremental Charge--Manual Svc Order - 1st | SOMAN | NA |
| | NRC - OC3 - Incremental Charge--Manual Svc Order - Add'l | SOMAN | NA |
| | NRC - OC3 -Incremental Cost - Manual Svc. Order vs. Elect-Disconnect-1st | SOMAN | NA |
| | NRC - OC3 -Incremental Cost - Manual Svc. Order vs. Elect-Disconnect-Add'l | SOMAN | NA |
| | NRC-All Existing Combination "Switch As Is" Conversion Charge (Note 6) | | |
| | NRC-OC-3 COMBINATION - "Switch As Is" Conversion Charge - 1st | UNCCC | \$54.09 |
| | NRC-OC-3 COMBINATION - "Switch As Is" Conversion Charge - Add'l | UNCCC | \$32.16 |
| | NRC - OC-3 COMBINATION - "Switch As Is" Conversion Charge - Disconnect | UNCCC | \$0.00 |
| | NRC - OC-3 COMBINATION - "Switch As Is" Conversion Charge - Disconnect | UNCCC | \$0.00 |
| | Local Loop - OC12 | | |
| | Local Loop - OC12 - per Mile | TBA | \$40.80 |
| | Local Loop - OC12 - per Facility Termination | TBA | \$2,457 |
| | NRC - Ordinarily Combined in GA (Note 5) | | |
| | NRC - OC12 - Facility Termination - 1st | TBA | NA |
| | NRC - OC12 - Facility Termination - Add'l | TBA | NA |
| | NRC - OC12 - Facility Termination - Disconnect - 1st | TBA | NA |
| | NRC - OC12 - Facility Termination - Disconnect - Add'l | TBA | NA |
| | NRC - Electronic Svc Order, per LSR | SOMEK | NA |
| | NRC -OC12 - Incremental Charge - Manual Svc Order - 1st | SOMAN | NA |
| | NRC - OC12 - Incremental Charge - Manual Svc Order - Add'l | SOMAN | NA |
| | NRC - OC12 - Incremental Cost-Manual Svc. Order vs. Elect-Disconnect-1st | SOMAN | NA |
| | NRC - OC12 - Incremental Cost-Manual Svc. Order vs. Elect-Disconnect-Add'l | SOMAN | NA |
| | NRC-All Existing Combination "Switch As Is" Conversion Charge (Note 6) | | |
| | NRC-OC-12 COMBINATION - "Switch As Is" Conversion Charge - 1st | UNCCC | \$54.09 |

BELLSOUTH/ADELPHIA RATES
NETWORK ELEMENTS
AND OTHER SERVICES

| ENHANCED EXTENDED LINKS (EELs) | | | |
|---------------------------------------|---|-------------|-----------|
| | New EEL rates are the sum of the individual UNE network elements (interoffice transport and loop [channelization if applicable]. | | |
| | | USOC | KY |
| | NRC-OC-12 COMBINATION - "Switch As Is" Conversion Charge - Add'l | UNCCC | \$32.16 |
| | NRC- OC-12 COMBINATION - "Switch As Is" Conversion Charge - Disconne | UNCCC | \$0.00 |
| | NRC- OC-12 COMBINATION - "Switch As Is" Conversion Charge - Disconne | UNCCC | \$0.00 |
| | Local Loop - OC48 | | |
| | Local Loop - OC48 - per Mile | TBA | \$133.84 |
| | Local Loop - OC48 - per Facility Termination | TBA | \$2,129 |
| | Local Loop - OC12 interface on OC48 Facility | TBA | \$725.77 |
| | NRC - Ordinarily Combined in GA (Note 5) | | |
| | NRC - OC48 - Facility Termination - 1st | TBA | NA |
| | NRC - OC48 - Facility Termination - Add'l | TBA | NA |
| | NRC - OC48 - Interface OC12 on OC48 - 1st | TBA | NA |
| | NRC - OC48 - Interface OC12 on OC48 - Add'l | TBA | NA |
| | NRC - OC48 - Facility Termination - Disconnect - 1st | TBA | NA |
| | NRC - OC48 - Facility Termination - Disconnect - Add'l | TBA | NA |
| | NRC - OC48- Interface OC12 on OC48 - Disconnect - 1st | TBA | NA |
| | NRC - OC48 - Interface OC12 on OC48 - Disconnect - Add'l | TBA | NA |
| | NRC - Electronic Svc Order, per LSR | SOMEK | NA |
| | NRC - OC48 - Facility Termination-Manual Svc Order vs Electronic-Disconne | SOMAN | NA |
| | NRC - OC48 - Facility Termination-Manual Svc Order vs Electronic-Disconne | SOMAN | NA |
| | NRC - OC48 - Interface - Manual Svc Order vs Electronic-Disconnect-1st | SOMAN | NA |
| | NRC - OC48 - Interface - Manual Svc Order vs Electronic-Disconnect-Add'l | SOMAN | NA |
| | NRC - OC-48 - Incremental Charge--Manual Svc Order-1st | SOMAN | NA |
| | NRC - OC-48 - Incremental Charge--Manual Svc Order-Add'l | SOMAN | NA |
| | NRC - OC48 - Interface OC12 on OC48 - Incremental Charge--Manual Svc O | SOMAN | NA |
| | NRC - OC48 - Interface OC12 on OC48 - Incremental Charge--Manual Svc O | SOMAN | NA |
| | NRC-All Existing Combination "Switch As Is" Conversion Charge (Note 6) | | |
| | NRC-OC-48 COMBINATION - "Switch As Is" Conversion Charge - 1st | UNCCC | \$54.09 |
| | NRC-OC-48 COMBINATION - "Switch As Is" Conversion Charge - Add'l | UNCCC | \$32.16 |
| | NRC- OC-48 COMBINATION - "Switch As Is" Conversion Charge - Disconne | UNCCC | \$0.00 |
| | NRC- OC-48 COMBINATION - "Switch As Is" Conversion Charge - Disconne | UNCCC | \$0.00 |
| | Interoffice Channels: | | |
| | Interoffice Channel - Dedicated - 2-wire VG | | |
| | Interoffice Channel - Dedicated 2-wire VG - per mile per month | 1L5XX | \$0.03 |
| | Interoffice Channel - Dedicated 2-wire VG - Facility Termination per month | U1TV2 | \$27.66 |
| | NRC - Ordinarily Combined in GA (Note 5) | | |
| | NRC - 2-wire VG Interoffice Channel - Facility Termination - 1st | U1TV2 | NA |
| | NRC - 2-wire VG Interoffice Channel - Facility Termination - Add'l | U1TV2 | NA |
| | NRC - Electronic Svc Order, per LSR | SOMEK | NA |
| | NRC - 2-wire VG Interoffice Channel - Incremental Charge--Manual Svc Orde | SOMAN | NA |
| | NRC - 2-wire VG Interoffice Channel - Incremental Charge--Manual Svc Orde | SOMAN | NA |
| | NRC - 2-wire VG Interoffice Channel - Incremental Charge--Manual Svc Orde | SOMAN | NA |
| | NRC - 2-wire VG Interoffice Channel - Incremental Charge--Manual Svc Orde | SOMAN | NA |
| | NRC-All Existing Combination "Switch As Is" Conversion Charge (Note 6) | | |
| | NRC-2/4-WIRE VG COMBINATION - "Switch As Is" Conversion Charge - 1st | UNCCC | \$54.09 |
| | NRC-2/4-WIRE VG COMBINATION - "Switch As Is" Conversion Charge - Ad | UNCCC | \$32.16 |
| | NRC- 2/4-WIRE VG COMBINATION - "Switch As Is" Conversion Charge - Di | UNCCC | \$0.00 |
| | NRC- 2/4-WIRE VG COMBINATION - "Switch As Is" Conversion Charge - Di | UNCCC | \$0.00 |
| | Interoffice Channel - Dedicated - 4-wire VG | | |
| | Interoffice Channel - Dedicated 4-wire VG - per mile per month | 1L5XX | NA |

BELLSOUTH/ADELPHIA RATES
NETWORK ELEMENTS
AND OTHER SERVICES

| ENHANCED EXTENDED LINKS (EELs) | | | |
|--|--|-------|----------|
| New EEL rates are the sum of the individual UNE network elements (interoffice transport and loop [channelization if applicable]. | | | |
| | | USOC | KY |
| | Interoffice Channel - Dedicated 4-wire VG - Facility Termination per month | U1TV4 | NA |
| | NRC - Ordinarily Combined in GA (Note 5) | | |
| | NRC - 4-wire VG Interoffice Channel - Facility Termination - 1st | U1TV4 | NA |
| | NRC - 4-wire VG Interoffice Channel - Facility Termination - Add'l | U1TV4 | NA |
| | NRC - Electronic Svc Order, per LSR | SOMEK | NA |
| | NRC - 4-wire VG Interoffice Channel - Incremental Charge--Manual Svc Order | SOMAN | NA |
| | NRC - 4-wire VG Interoffice Channel - Incremental Charge--Manual Svc Order | SOMAN | NA |
| | NRC - 4-wire VG Interoffice Channel - Incremental Charge--Manual Svc Order | SOMAN | NA |
| | NRC - 4-wire VG Interoffice Channel - Incremental Charge--Manual Svc Order | SOMAN | NA |
| | NRC-All Existing Combination "Switch As Is" Conversion Charge (Note 6) | | |
| | NRC-2/4-WIRE VG COMBINATION - "Switch As Is" Conversion Charge - 1st | UNCCC | \$54.09 |
| | NRC-2/4-WIRE VG COMBINATION - "Switch As Is" Conversion Charge - Ad | UNCCC | \$32.16 |
| | NRC- 2/4-WIRE VG COMBINATION - "Switch As Is" Conversion Charge - Di | UNCCC | \$0.00 |
| | NRC- 2/4-WIRE VG COMBINATION - "Switch As Is" Conversion Charge - Di | UNCCC | \$0.00 |
| | Interoffice Channel - Dedicated - DS0 - 56kbps | | |
| | Interoffice Channel - Dedicated - DS0 - 56kbps - per mile per month | 1L5XX | \$0.0301 |
| | Interoffice Channel - Dedicated - DS0 - 56 kbps - Facility Termination per month | U1TD5 | \$26.95 |
| | NRC - Ordinarily Combined in GA (Note 5) | | |
| | NRC - 4-wire 56kbps Interoffice Channel - Facility Termination - 1st | U1TD5 | NA |
| | NRC - 4-wire 56 kbps Interoffice Channel - Facility Termination - Add'l | U1TD5 | NA |
| | NRC - Electronic Svc Order, per LSR | SOMEK | NA |
| | NRC - 4-wire 56 kbps Interoffice Channel - Incremental Charge--Manual Svc Order | SOMAN | NA |
| | NRC - 4-wire 56 kbps Interoffice Channel - Incremental Charge--Manual Svc Order | SOMAN | NA |
| | NRC - 4-wire 56 kbps Interoffice Channel - Incremental Charge--Manual Svc Order | SOMAN | NA |
| | NRC - 4-wire 56 kbps Interoffice Channel - Incremental Charge--Manual Svc Order | SOMAN | NA |
| | NRC-All Existing Combination "Switch As Is" Conversion Charge (Note 6) | | |
| | NRC-2/4-WIRE VG COMBINATION - "Switch As Is" Conversion Charge - 1st | UNCCC | \$54.09 |
| | NRC-2/4-WIRE VG COMBINATION - "Switch As Is" Conversion Charge - Ad | UNCCC | \$32.16 |
| | NRC- 2/4-WIRE VG COMBINATION - "Switch As Is" Conversion Charge - Di | UNCCC | \$0.00 |
| | NRC- 2/4-WIRE VG COMBINATION - "Switch As Is" Conversion Charge - Di | UNCCC | \$0.00 |
| | Interoffice Channel - Dedicated - DS0 - 64kbps | | |
| | Interoffice Channel - Dedicated - DS0 - 64kbps - per mile per month | 1L5XX | \$0.0301 |
| | Interoffice Channel - Dedicated - DS0 - 64 kbps - Facility Termination per month | U1TD6 | \$26.95 |
| | NRC - Ordinarily Combined in GA (Note 5) | | |
| | NRC - 4-wire 64kbps Interoffice Channel - Facility Termination - 1st | U1TD6 | NA |
| | NRC - 4-wire 64 kbps Interoffice Channel - Facility Termination - Add'l | U1TD6 | NA |
| | NRC - Electronic Svc Order, per LSR | SOMEK | NA |
| | NRC - 4-wire 64 kbps Interoffice Channel - Incremental Charge--Manual Svc Order | SOMAN | NA |
| | NRC - 4-wire 64 kbps Interoffice Channel - Incremental Charge--Manual Svc Order | SOMAN | NA |
| | NRC - 4-wire 64 kbps Interoffice Channel - Incremental Charge--Manual Svc Order | SOMAN | NA |
| | NRC - 4-wire 64 kbps Interoffice Channel - Incremental Charge--Manual Svc Order | SOMAN | NA |
| | NRC-All Existing Combination "Switch As Is" Conversion Charge (Note 6) | | |
| | NRC-2/4-WIRE VG COMBINATION - "Switch As Is" Conversion Charge - 1st | UNCCC | \$54.09 |
| | NRC-2/4-WIRE VG COMBINATION - "Switch As Is" Conversion Charge - Ad | UNCCC | \$32.16 |
| | NRC- 2/4-WIRE VG COMBINATION - "Switch As Is" Conversion Charge - Di | UNCCC | \$0.00 |
| | NRC- 2/4-WIRE VG COMBINATION - "Switch As Is" Conversion Charge - Di | UNCCC | \$0.00 |
| | Interoffice Channel - Dedicated - DS1 | | |
| | Interoffice Channel - Dedicated - DS1 - per mile per month | 1L5XX | \$0.45 |
| | Interoffice Channel - Dedicated - DS1 - Facility Termination per month | U1TF1 | \$55.05 |

BELLSOUTH/ADELPHIA RATES
NETWORK ELEMENTS
AND OTHER SERVICES

| ENHANCED EXTENDED LINKS (EELs) | | | |
|---------------------------------------|--|-------------|------------|
| | New EEL rates are the sum of the individual UNE network elements (interoffice transport and loop [channelization if applicable]. | | |
| | | USOC | KY |
| | NRC - Ordinarily Combined in GA (Note 5) | | |
| | NRC - DS1 Interoffice Channel - Facility Termination - 1st | U1TF1 | NA |
| | NRC - DS1 Interoffice Channel - Facility Termination - Add'l | U1TF1 | NA |
| | NRC - Electronic Svc Order, per LSR | SOMEK | NA |
| | NRC - DS1 Interoffice Channel - Incremental Charge--Manual Svc Order - 1st | SOMAN | NA |
| | NRC - DS1 Interoffice Channel - Incremental Charge--Manual Svc Order - Ad | SOMAN | NA |
| | NRC - DS1 Interoffice Channel - Incremental Charge--Manual Svc Order - Dis | SOMAN | NA |
| | NRC - DS1 Interoffice Channel - Incremental Charge--Manual Svc Order - Dis | SOMAN | NA |
| | NRC-All Existing Combination "Switch As Is" Conversion Charge (Note 6) | | |
| | NRC-DS1 COMBINATION - "Switch As Is" Conversion Charge - 1st | UNCCC | \$54.09 |
| | NRC-DS1 COMBINATION - "Switch As Is" Conversion Charge - Add'l | UNCCC | \$32.16 |
| | NRC - DS1 COMBINATION - "Switch As Is" Conversion Charge - Disconnect | UNCCC | \$0.00 |
| | NRC - DS1 COMBINATION - "Switch As Is" Conversion Charge - Disconnect | UNCCC | \$0.00 |
| | Interoffice Channel - Dedicated - DS3 - per mile per month | | |
| | Interoffice Channel - Dedicated - DS3 - per mile per month | 1L5XX | \$12.06 |
| | Interoffice Channel - Dedicated - DS3 - Facility Termination per month | U1TF3 | \$1,112.02 |
| | NRC - Ordinarily Combined in GA (Note 5) | | |
| | NRC - DS3 Interoffice Channel - Facility Termination - 1st | U1TF3 | NA |
| | NRC - DS3 Interoffice Channel - Facility Termination - Add'l | U1TF3 | NA |
| | NRC - Electronic Svc Order, per LSR | SOMEK | NA |
| | NRC - DS3 Interoffice Channel - Incremental Charge--Manual Svc Order - 1st | SOMAN | NA |
| | NRC - DS3 Interoffice Channel - Incremental Charge--Manual Svc Order - Ad | SOMAN | NA |
| | NRC - DS3 Interoffice Channel - Incremental Charge--Manual Svc Order - Dis | SOMAN | NA |
| | NRC - DS3 Interoffice Channel - Incremental Charge--Manual Svc Order - Dis | SOMAN | NA |
| | NRC-All Existing Combination "Switch As Is" Conversion Charge (Note 6) | | |
| | NRC-DS3 COMBINATION - "Switch As Is" Conversion Charge - 1st | UNCCC | \$54.09 |
| | NRC-DS3 COMBINATION - "Switch As Is" Conversion Charge - Add'l | UNCCC | \$32.16 |
| | NRC - DS3 COMBINATION - "Switch As Is" Conversion Charge - Disconnect | UNCCC | \$0.00 |
| | NRC - DS3 COMBINATION - "Switch As Is" Conversion Charge - Disconnect | UNCCC | \$0.00 |
| | Interoffice Channel - Dedicated - STS-1 | | |
| | Interoffice Channel - Dedicated - STS-1 - per mile per month | 1L5XX | \$12.62 |
| | Interoffice Channel - Dedicated - STS-1 - Facility Termination per month | U1TFS | \$1,204 |
| | NRC - Ordinarily Combined in GA (Note 5) | | |
| | NRC - STS-1 Interoffice Channel - Facility Termination - 1st | U1TFS | NA |
| | NRC - STS-1 Interoffice Channel - Facility Termination - Add'l | U1TFS | NA |
| | NRC - Electronic Svc Order, per LSR | SOMEK | NA |
| | NRC - STS-1 Interoffice Channel - Incremental Charge--Manual Svc Order - 1st | SOMAN | NA |
| | NRC - STS-1 Interoffice Channel - Incremental Charge--Manual Svc Order - Ad | SOMAN | NA |
| | NRC - STS-1 Interoffice Channel - Incremental Charge--Manual Svc Order - Dis | SOMAN | NA |
| | NRC - STS-1 Interoffice Channel - Incremental Charge--Manual Svc Order - Dis | SOMAN | NA |
| | NRC-All Existing Combination "Switch As Is" Conversion Charge (Note 6) | | |
| | NRC-STs-1 COMBINATION - "Switch As Is" Conversion Charge - 1st | UNCCC | \$54.09 |
| | NRC-STs-1 COMBINATION - "Switch As Is" Conversion Charge - Add'l | UNCCC | \$32.16 |
| | NRC - STS-1 COMBINATION - "Switch As Is" Conversion Charge - Disconnect | UNCCC | \$0.00 |
| | NRC - STS-1 COMBINATION - "Switch As Is" Conversion Charge - Disconnect | UNCCC | \$0.00 |
| | Interoffice Channel - OC3 | | |
| | Interoffice Channel - OC3 - per Mile | 1L5XX | \$27.97 |
| | Interoffice Channel - OC3 - per Facility Termination | TBA | \$3,390 |
| | NRC - Ordinarily Combined in GA (Note 5) | | |

BELLSOUTH/ADELPHIA RATES
NETWORK ELEMENTS
AND OTHER SERVICES

| ENHANCED EXTENDED LINKS (EELs) | | | |
|--------------------------------|--|-------|----------|
| | New EEL rates are the sum of the individual UNE network elements (interoffice transport and loop [channelization if applicable]. | | |
| | | USOC | KY |
| | NRC - OC3 - Facility Termination - 1st | TBA | NA |
| | NRC - OC3 - Facility Termination - Add'l | TBA | NA |
| | NRC - OC3 - Facility Termination - Disconnect - 1st | TBA | NA |
| | NRC - OC3 - Facility Termination - Disconnect - Add'l | TBA | NA |
| | NRC - Electronic Svc Order, per LSR | SOMEK | NA |
| | NRC - OC3 - Incremental Charge--Manual Svc Order - 1st | SOMAN | NA |
| | NRC - OC3 - Incremental Charge--Manual Svc Order - Add'l | SOMAN | NA |
| | NRC - OC3 -Incremental Cost - Manual Svc. Order vs. Elect-Disconnect-1st | SOMAN | NA |
| | NRC - OC3 -Incremental Cost - Manual Svc. Order vs. Elect-Disconnect-Add'l | SOMAN | NA |
| | NRC-All Existing Combination "Switch As Is" Conversion Charge (Note 6) | | |
| | NRC-OC-3 COMBINATION - "Switch As Is" Conversion Charge - 1st | UNCCC | \$54.09 |
| | NRC-OC-3 COMBINATION - "Switch As Is" Conversion Charge - Add'l | UNCCC | \$32.16 |
| | NRC - OC-3 COMBINATION - "Switch As Is" Conversion Charge - Disconnect | UNCCC | \$0.00 |
| | NRC - OC-3 COMBINATION - "Switch As Is" Conversion Charge - Disconnect | UNCCC | \$0.00 |
| | Interoffice Channel - OC12 | | |
| | Interoffice Channel - OC12 - per Mile | TBA | \$84.88 |
| | Interoffice Channel - OC12 - per Facility Termination | TBA | \$12,344 |
| | NRC - Ordinarily Combined in GA (Note 5) | | |
| | NRC - OC12 - Facility Termination - 1st | TBA | NA |
| | NRC - OC12 - Facility Termination - Add'l | TBA | NA |
| | NRC - OC12 - Facility Termination - Disconnect - 1st | TBA | NA |
| | NRC - OC12 - Facility Termination - Disconnect - Add'l | TBA | NA |
| | NRC - Electronic Svc Order, per LSR | SOMEK | NA |
| | NRC -OC12 - Incremental Charge - Manual Svc Order - 1st | SOMAN | NA |
| | NRC - OC12 - Incremental Charge - Manual Svc Order - Add'l | SOMAN | NA |
| | NRC - OC12 - Incremental Cost-Manual Svc. Order vs. Elect-Disconnect-1st | SOMAN | NA |
| | NRC - OC12 - Incremental Cost-Manual Svc. Order vs. Elect-Disconnect-Add'l | SOMAN | NA |
| | NRC-All Existing Combination "Switch As Is" Conversion Charge (Note 6) | | |
| | NRC-OC-12 COMBINATION - "Switch As Is" Conversion Charge - 1st | UNCCC | \$54.09 |
| | NRC-OC-12 COMBINATION - "Switch As Is" Conversion Charge - Add'l | UNCCC | \$32.16 |
| | NRC - OC-12 COMBINATION - "Switch As Is" Conversion Charge - Disconnect | UNCCC | \$0.00 |
| | NRC - OC-12 COMBINATION - "Switch As Is" Conversion Charge - Disconnect | UNCCC | \$0.00 |
| | Interoffice Channel - OC48 | | |
| | Interoffice Channel - OC48 - per Mile | TBA | \$138.02 |
| | Interoffice Channel - OC48 - per Facility Termination | TBA | \$16,017 |
| | Interoffice Channel - OC12 interface on OC48 Facility | TBA | \$1,497 |
| | NRC - Ordinarily Combined in GA (Note 5) | | |
| | NRC - OC48 - Facility Termination - 1st | TBA | NA |
| | NRC - OC48 - Facility Termination - Add'l | TBA | NA |
| | NRC - OC48 - Interface OC12 on OC48 - 1st | TBA | NA |
| | NRC - OC48 - Interface OC12 on OC48 - Add'l | TBA | NA |
| | NRC - OC48 - Facility Termination - Disconnect - 1st | TBA | NA |
| | NRC - OC48 - Facility Termination - Disconnect - Add'l | TBA | NA |
| | NRC - OC48- Interface OC12 on OC48 - Disconnect - 1st | TBA | NA |
| | NRC - OC48 - Interface OC12 on OC48 - Disconnect - Add'l | TBA | NA |
| | NRC - Electronic Svc Order, per LSR | SOMEK | NA |
| | NRC - OC48 - Facility Termination-Manual Svc Order vs Electronic-Disconnect | SOMAN | NA |
| | NRC - OC48 - Facility Termination-Manual Svc Order vs Electronic-Disconnect | SOMAN | NA |
| | NRC - OC48 - Interface - Manual Svc Order vs Electronic-Disconnect-1st | SOMAN | NA |
| | NRC - OC48 - Interface - Manual Svc Order vs Electronic-Disconnect-Add'l | SOMAN | NA |

BELLSOUTH/ADELPHIA RATES
NETWORK ELEMENTS
AND OTHER SERVICES

| ENHANCED EXTENDED LINKS (EELs) | | | |
|--|--|-------|----------|
| New EEL rates are the sum of the individual UNE network elements (interoffice transport and loop [channelization if applicable]. | | | |
| | | USOC | KY |
| | NRC - OC-48 - Incremental Charge--Manual Svc Order-1st | SOMAN | NA |
| | NRC - OC-48 - Incremental Charge--Manual Svc Order-Add'l | SOMAN | NA |
| | NRC - OC48 - Interface OC12 on OC48 - Incremental Charge--Manual Svc O | SOMAN | NA |
| | NRC - OC48 - Interface OC12 on OC48 - Incremental Charge--Manual Svc O | SOMAN | NA |
| NRC-All Existing Combination "Switch As Is" Conversion Charge (Note 6) | | | |
| | NRC-OC-48 COMBINATION - "Switch As Is" Conversion Charge - 1st | UNCCC | \$54.09 |
| | NRC-OC-48 COMBINATION - "Switch As Is" Conversion Charge - Add'l | UNCCC | \$32.16 |
| | NRC- OC-48 COMBINATION - "Switch As Is" Conversion Charge - Disconne | UNCCC | \$0.00 |
| | NRC- OC-48 COMBINATION - "Switch As Is" Conversion Charge - Disconne | UNCCC | \$0.00 |
| Channelization: | | | |
| DS3 Channelization | | | |
| | DS3 Channelized System per month | MQ3 | \$236.32 |
| | DS3 Interface per month (DS1 COCI) | UC1D1 | \$8.52 |
| NRC - Ordinarily Combined in GA (Note 5) | | | |
| | NRC - DS3 Channelization - 1st | MQ3 | NA |
| | NRC - DS3 Channelization - Add'l | MQ3 | NA |
| | NRC - Channel Activation - 1st | UC1D1 | NA |
| | NRC - Channel Activation - Add'l | UC1D1 | NA |
| | NRC - Electronic Svc Order, per LSR | SOMEK | NA |
| | NRC - DS3 Channelization - Incremental Charge--Manual Svc Order - 1st | SOMAN | NA |
| | NRC - DS3 Channelization - Incremental Charge--Manual Svc Order - Add'l | SOMAN | NA |
| | NRC - DS3 Channelization - Incremental Charge--Manual Svc Order - Discor | SOMAN | NA |
| | NRC - DS3 Channelization - Incremental Charge--Manual Svc Order - Discor | SOMAN | NA |
| NRC-All Existing Combination "Switch As Is" Conversion Charge (Note 6) | | | |
| | NRC-ST3-1 COMBINATION - "Switch As Is" Conversion Charge - 1st | UNCCC | \$54.09 |
| | NRC-ST3-1 COMBINATION - "Switch As Is" Conversion Charge - Add'l | UNCCC | \$32.16 |
| | NRC- ST3-1 COMBINATION - "Switch As Is" Conversion Charge - Disconne | UNCCC | \$0.00 |
| | NRC- ST3-1 COMBINATION - "Switch As Is" Conversion Charge - Disconne | UNCCC | \$0.00 |
| OR | | | |
| | NRC-DS3 COMBINATION - "Switch As Is" Conversion Charge - 1st | UNCCC | \$54.09 |
| | NRC-DS3 COMBINATION - "Switch As Is" Conversion Charge - Add'l | UNCCC | \$32.16 |
| | NRC- DS3 COMBINATION - "Switch As Is" Conversion Charge - Disconnect | UNCCC | \$0.00 |
| | NRC- DS3 COMBINATION - "Switch As Is" Conversion Charge - Disconnect | UNCCC | \$0.00 |
| DS1 Channelization | | | |
| | DS1 Channelized System per month | MQ1 | \$200.01 |
| | OCU-DP(data) interface card per month (2.4-64kbs) | 1D1DD | \$2.94 |
| | VG interface card per month | 1D1VG | \$1.40 |
| | 2-wire ISDN(BRITE card) per month | UC1CA | \$4.04 |
| NRC - Ordinarily Combined in GA (Note 5) | | | |
| | NRC - DS1 Channelization - 1st | MQ1 | NA |
| | NRC - DS1 Channelization - Add'l | MQ1 | NA |
| | NRC - Channel Activation VG - 1st | 1D1VG | NA |
| | NRC - Channel Activation VG - Add'l | 1D1VG | NA |
| | NRC - Channel Activation OCU-DP- 1st | 1D1DD | NA |
| | NRC - Channel Activation OCU-DP- Add'l | 1D1DD | NA |
| | NRC - Channel Activation BRITE - 1st | UC1CA | NA |
| | NRC - Channel Activation BRITE - Add'l | UC1CA | NA |
| | NRC - Electronic Svc Order, per LSR | SOMEK | NA |
| | NRC - DS1 Channelization - Incremental Charge--Manual Svc Order - 1st | SOMAN | NA |
| | NRC - DS1 Channelization - Incremental Charge--Manual Svc Order - Add'l | SOMAN | NA |

BELLSOUTH/ADELPHIA RATES
NETWORK ELEMENTS
AND OTHER SERVICES

| ENHANCED EXTENDED LINKS (EELs) | | | |
|--|--|-------|---------|
| New EEL rates are the sum of the individual UNE network elements (interoffice transport and loop [channelization if applicable]. | | | |
| | | USOC | KY |
| | NRC - DS1 Channelization - Incremental Charge--Manual Svc Order - Discor | SOMAN | NA |
| | NRC - DS1 Channelization - Incremental Charge--Manual Svc Order - Discor | SOMAN | NA |
| NRC-All Existing Combination "Switch As Is" Conversion Charge (Note 6) | | | |
| | NRC-DS1 COMBINATION - "Switch As Is" Conversion Charge - 1st | UNCCC | \$54.09 |
| | NRC-DS1 COMBINATION - "Switch As Is" Conversion Charge - Add'l | UNCCC | \$32.16 |
| | NRC- DS1 COMBINATION - "Switch As Is" Conversion Charge - Disconnect | UNCCC | \$0.00 |
| | NRC- DS1 COMBINATION - "Switch As Is" Conversion Charge - Disconnect | UNCCC | \$0.00 |
| Access to DCS - Customer Reconfiguration (FlexServ) | | | |
| | DS1 DSC Termination with DS0 Switching | TBD | TBD |
| | DS1 DSC Termination with DS1 Switching | TBD | TBD |
| | DS3 DSC Termination with DS1 Switching | TBD | TBD |
| NRC - Ordinarily Combined in GA: | | | |
| | NRC - Customer Configuration Establishment | TBD | TBD |
| | NRC - Customer Configuration Establishment - Disconnect | TBD | TBD |
| | NRC- DS1 DSC Termination with DS0 Switching - 1st | TBD | TBD |
| | NRC- DS1 DSC Termination with DS0 Switching - Add'l | TBD | TBD |
| | NRC- DS1 DSC Termination with DS0 Switching - Disconnect - 1st | TBD | TBD |
| | NRC- DS1 DSC Termination with DS0 Switching - Disconnect - Add'l | TBD | TBD |
| | NRC- DS1 DSC Termination with NRC- DS1 Switching - 1st | TBD | TBD |
| | NRC- DS1 DSC Termination with NRC- DS1 Switching - Add'l | TBD | TBD |
| | NRC- DS1 DSC Termination with NRC- DS1 Switching - Disconnect - 1st | TBD | TBD |
| | NRC- DS1 DSC Termination with NRC- DS1 Switching - Disconnect - Add'l | TBD | TBD |
| | NRC- DS3 DSC Termination with DS1 Switching - 1st | TBD | TBD |
| | NRC- DS3 DSC Termination with DS1 Switching - Add'l | TBD | TBD |
| | NRC- DS3 DSC Termination with DS1 Switching - Disconnect - 1st | TBD | TBD |
| | NRC- DS3 DSC Termination with DS1 Switching - Disconnect - Add'l | TBD | TBD |
| NRC-All Existing Combination "Switch As Is" Conversion Charge (Note 6) | | | |
| | NRC-DS1 COMBINATION - "Switch As Is" Conversion Charge - 1st | UNCCC | \$54.09 |
| | NRC-DS1 COMBINATION - "Switch As Is" Conversion Charge - Add'l | UNCCC | \$32.16 |
| | NRC- DS1 COMBINATION - "Switch As Is" Conversion Charge - Disconnect | UNCCC | \$0.00 |
| | NRC- DS1 COMBINATION - "Switch As Is" Conversion Charge - Disconnect | UNCCC | \$0.00 |
| Notes : | | | |
| | 1 Deaveraged Rates will be effective May 1, 2000 | | |
| | 2 New EELs will only be available in the State of Georgia and in density Zone 1 of the following MSAs in the | | |
| | Florida - Miami, Orlando, Ft. Lauderdale | | |
| | Louisiana - New Orleans | | |
| | N. Carolina - Greensboro, Charlotte | | |
| | Tennessee - Nashville | | |
| | 3 Unapproved rates are subject to true up. | | |
| | 4 Add together the recurring rates of all the applicable network elements in order to obtain total monthly rec | | |
| | * Examples: | | |
| | - 2-wire VG Loop + Voice Grade Interface Card + DS1 Channelization System + DS1 Interoffice Channe | | |
| | - DS1 Loop + DS1 Interface Card + DS3 Channelization System + DS3 Interoffice Channel | | |
| | - DS3 Local Channel + DS3 Interoffice Channel + DS3 Channelization System + DS1 Interface Card | | |
| | 5 The Ordinarily Combined in GA NRC applies to new combinations within the State of Georgia. | | |
| | 6 The "Switch As Is" NRC is a conversion charge. One SAI charge is applicable per circuit. | | |

BELLSOUTH/ADELPHIA RATES
NETWORK ELEMENTS
AND OTHER SERVICES

| DESCRIPTION | | KY |
|---|-------|-------------|
| Operational Support Systems | | |
| Recovery of incremental OSS costs, per CLP, per month | TBD | NA |
| RC - OSS OLEC Daily Usage File: Recording, Per Message | TBD | \$0.0008611 |
| RC- OSS OLEC Daily Usage File: Message Processing, Per Message | TBD | \$0.0032357 |
| RC - OSS OLEC Daily Usage File: Message Distribution, Per Magnetic Tape | TBD | \$55.68 |
| RC - OSS OLEC Daily Usage File: Data Transmission (CONNECT:DIRECT), Per | TBD | \$0.0000365 |
| Access Daily Usage File (ADUF) | | |
| RC - ADUF, Message Processing, per message | TBD | \$0.004 |
| RC - ADUF, Message Distribution, per Magnetic Tape provisioned | TBD | NA |
| RC - ADUF, Data Transmission (CONNECT:DIRECT), per message | TBD | \$0.001 |
| Enhanced Optional Daily Usage File (EODUF) | | |
| Enhanced Optional Daily Usage File: Message Processing , Per Message | TBD | \$0.004 |
| Enhanced Optional Daily Usage File: Message Processing, per magnetic tape | TBD | NA |
| Enhanced Optional Daily Usage File: Data Transmission (CONNECT:DIRECT), | TBD | NA |
| SWA 8XX Toll Free Dialing Ten Digit Screening Service (Note 1) | | |
| 8XX Access Ten Digit Screening (all types), per call (Note 2) | | |
| 8XX Access Ten Digit Screening Svc. W/8XX No. Delivery | N/A | NA |
| per query | N/A | \$0.0010 |
| for 8XX Numbers, with Optional Complex Features, per query | N/A | \$0.0011 |
| 8XX Access Ten Digit Screening Svc. W/POTS No. Delivery | | |
| per query | N/A | \$0.0010 |
| with Optional Complex Features, per query | N/A | \$0.0011 |
| 8XX Access Ten Digit Screening Svc. W/800 No. Delivery | | |
| per message | N/A | NA |
| for 8XX Numbers, w/Optional Complex Features, per message | N/A | NA |
| 8XX Access Ten Digit Screening Svc. W/POTS No. Delivery | | |
| per message | N/A | NA |
| with Optional Complex Features, per message | N/A | NA |
| Reservation Charge per 8XX number reserved | | |
| NRC - 1st | N8R1X | \$10.05 |
| NRC - Add'l | N8R1X | \$1.19 |
| NRC - Incremental Charge - Manual Service Order - 1st | SOMAN | NA |
| NRC - Incremental Charge - Manual Service Order - Add'l | SOMAN | NA |
| Per 8XX # Established w/o POTS (w/8XX No.) Translations | | |
| NRC - 1st | N/A | \$30.59 |
| NRC - Add'l | N/A | \$3.22 |
| NRC - Disconnect Charge - 1st | N/A | NA |
| NRC - Disconnect Charge - Add'l | N/A | NA |
| NRC - Incremental Charge - Manual Service Order - 1st | SOMAN | NA |
| NRC - Incremental Charge - Manual Service Order - Add'l | SOMAN | NA |
| NRC - Incremental Charge - Manual Service Order - Disconnect | SOMAN | NA |
| Per 8XX # Established with POTS Translations | | |
| NRC - 1st | N8FTX | \$30.59 |
| NRC - Add'l | N8FTX | \$3.22 |
| NRC - Disconnect Charge - 1st | N8FTX | NA |
| NRC - Disconnect Charge - Add'l | N8FTX | NA |
| NRC - Incremental Charge - Manual Service Order - 1st | SOMAN | NA |
| NRC - Incremental Charge - Manual Service Order - Add'l | SOMAN | NA |
| NRC - Incremental Charge - Manual Service Order - Disconnect | SOMAN | NA |
| Customized Area of Service per 8XX Number | | |
| NRC - 1st | N8FCX | \$6.97 |
| NRC - Add'l | N8FCX | \$3.49 |
| NRC - Incremental Charge - Manual Service Order - 1st | SOMAN | NA |
| NRC - Incremental Charge - Manual Service Order - Add'l | SOMAN | NA |

BELLSOUTH/ADELPHIA RATES
NETWORK ELEMENTS
AND OTHER SERVICES

| DESCRIPTION | | KY |
|--|-------|------------------|
| Multiple Inter LATA Carrier Routing per Carrier Requested per 8XX # | | |
| NRC - 1st | N8FMX | \$8.16 |
| NRC - Add'l | N8FMX | \$4.67 |
| NRC - Incremental Charge - Manual Service Order - 1st | SOMAN | NA |
| NRC - Incremental Charge - Manual Service Order - Add'l | SOMAN | NA |
| Change Charge per request | | |
| NRC - 1st | N8FAX | \$11.24 |
| NRC - Add'l | N8FAX | \$1.19 |
| NRC - Incremental Charge - Manual Service Order - 1st | SOMAN | NA |
| NRC - Incremental Charge - Manual Service Order - Add'l | SOMAN | NA |
| Call Handling and Destination Features | | |
| NRC - 1st | N8FDX | \$6.97 |
| NRC - Add'l | N8FDX | \$6.97 |
| LINE INFORMATION DATABASE ACCESS (LIDB) | | |
| LIDB Common Transport per query | OQT | \$0.00006 |
| LIDB Validation per query | OQU | \$0.00938 |
| LIDB Originating Point Code Establishment or Change - NRC | N/A | \$107.60 |
| NRC - Incremental Charge - Electronic Service Order | TBD | NA |
| NRC - Incremental Charge - Manual Service Order - 1st | SOMAN | NA |
| NRC - Incremental Charge - Manual Service Order - Add'l | SOMAN | NA |
| CCS7 SIGNALING TRANSPORT SERVICE | | |
| CCS7 Signaling Connection, per link (A link) per month | | \$16.31 |
| NRC | | \$354.95 |
| NRC - Disconnect | | NA |
| NRC - Incremental Charge - Manual Service Order | SOMAN | NA |
| NRC - Incremental Charge - Manual Service Order - Disconnect | SOMAN | NA |
| CCS7 Signaling Connection, per link (B link) (also known as D link) per month | | \$16.31 |
| NRC | | \$354.95 |
| NRC - Disconnect | | NA |
| NRC - Incremental Charge - Manual Service Order | SOMAN | NA |
| NRC - Incremental Charge - Manual Service Order - Disconnect | SOMAN | NA |
| CCS7 Signaling Termination, per STP port per month | | \$174.08 |
| CCS7 Signaling Usage, per ISUP message | | \$0.000037893 |
| (applicable when measurement and billing capability exists.) | | |
| CCS7 Signaling Usage, per TCAP message | | \$0.000102042 |
| (applicable when measurement and billing capability exists.) | | |
| CCS7 Signaling Usage Surrogate, per link per LATA per mo (9) | | \$329.98 |
| CCS7 Signaling Point Code, Establishment or Change, per STP affected | | |
| NRC | | \$62.00 |
| OPERATOR CALL PROCESSING | | |
| Operator Provided Call Handling per min - Using BST LIDB | | \$1.6016 |
| Call Completion Access Termination Charge per call attempt | N/A | NA |
| Operator Provided Call Handling per min - Using Foreign LIDB | | \$1.6249 |
| Call Completion Access Termination Charge per call attempt | N/A | NA |
| Operator Provided Call Handling, per call | | NA |
| Fully Automated Call Handling per call - Using BST LIDB | | \$0.0856 |
| Fully Automated Call Handling per call - Using Foreign LIDB | | \$0.1071 |
| Professional recording of name (OCP alone) | | USOD1 \$7,000.00 |
| Professional recording of name (DA and OCP alone) | | USOD1 \$7,000.00 |
| DRAM or front-end loading, per TOPS switch | | USOD2 \$250.00 |
| AABS or back-end loading, per IVS | | USOD2 \$225.00 |
| EBAS or 0- automation loading, per NAV shelf | | USOD2 \$270.00 |
| Recording Charge per Branded Announcement - Disconnect - Initial | | N/A NA |

BELLSOUTH/ADELPHIA RATES
NETWORK ELEMENTS
AND OTHER SERVICES

| DESCRIPTION | | KY |
|--|-------|------------|
| Recording Charge per Branded Announcement – Disconnect – Subsequent | N/A | NA |
| INWARD OPERATOR SERVICES | | |
| Verification, per minute | N/A | NA |
| Verification and Emergency Interrupt, per minute | N/A | NA |
| Verification, per call | VIL | \$1.00 |
| Verification and Emergency Interrupt, per call | N/A | \$1.111 |
| DIRECTORY ASSISTANCE SERVICES | | |
| Directory Assist Call Completion Access Svc (DACC), per call attempt | N/A | \$0.10 |
| Call Completion Access Term charge per completed call | N/A | NA |
| Number Services Intercept per query | N/A | \$0.0086 |
| Number Services Intercept per Intercept Query Update | N/A | \$0.0055 |
| Directory Assistance Access Service Calls, per call | N/A | \$0.275 |
| Professional recording of name (DA alone) | N/A | \$3,000.00 |
| Professional recording of name (DA and OCP alone) | N/A | \$7,000.00 |
| DRAM or front-end loading, per TOPS switch | N/A | \$250.00 |
| AABS or back-end loading, per IVS | N/A | \$225.00 |
| EBAS or 0- automation loading, per NAV shelf | N/A | \$270.00 |
| Recording Charge per Branded Announcement – Disconnect – Initial | N/A | NA |
| Recording Charge per Branded Announcement – Disconnect – Subsequent | N/A | NA |
| Directory Transport | | |
| Directory Transport - Local Channel DS1, per month | N/A | \$36.32 |
| NRC - 1st | N/A | \$637.46 |
| NRC - Add'l | N/A | \$546.94 |
| NRC - Disconnect Charge - 1st | N/A | NA |
| NRC - Disconnect Charge - Add'l | N/A | NA |
| NRC - Incremental Charge-Manual Svc Order - NRC - 1st | SOMAN | NA |
| NRC - Incremental Charge-Manual Svc Order - NRC -add'l | TBD | NA |
| NRC - Incremental Charge-Manual Svc Order - NRC-Disconnect | SOMAN | NA |
| Directory Transport - Dedicated DS1 Level Interoffice per mile per mo | N/A | \$0.45 |
| Directory Transport - Dedicated DS1 Level Interoffice per facility termination per m | N/A | \$55.05 |
| NRC - 1st | N/A | \$298.18 |
| NRC - Add'l | N/A | \$231.18 |
| NRC - Disconnect Charge - 1st | N/A | NA |
| NRC - Disconnect Charge - Add'l | N/A | NA |
| NRC - Incremental Charge - Manual Service Order - 1st | SOMAN | NA |
| NRC - Incremental Charge - Manual Service Order - Add'l | SOMAN | NA |
| NRC - Incremental Charge - Manual Service Order - Disconnect - 1st | SOMAN | NA |
| NRC - Incremental Charge - Manual Service Order - Disconnect - Add'l | SOMAN | NA |
| Switched Common Transport per DA Access Service per call | N/A | \$0.000175 |
| Switched Common Transport per DA Access Service per call per mile | N/A | \$0.000004 |
| Access Tandem Switching per DA Access Service per call | N/A | \$0.000783 |
| DA Interconnection, per DA Access Service Call | N/A | NA |
| Directory Transport-Installation NRC, per trunk or signaling connection | N/A | |
| NRC - 1st | N/A | \$501.98 |
| NRC - Add'l | N/A | \$13.32 |
| NRC - Disconnect Charge - 1st | N/A | NA |
| NRC - Disconnect Charge - Add'l | N/A | NA |
| NRC - Incremental Charge - Manual Service Order - 1st | SOMAN | NA |
| NRC - Incremental Charge - Manual Service Order - Add'l | SOMAN | NA |
| NRC - Manual Service Order - 1st | TBD | NA |
| NRC - Manual Service Order - Add'l | TBD | NA |
| Directory Assistance Database Service (DADS) | | |
| Directory Assistance Database Service charge per listing | N/A | \$0.0193 |

BELLSOUTH/ADELPHIA RATES
NETWORK ELEMENTS
AND OTHER SERVICES

| DESCRIPTION | | KY |
|---|-------|------------|
| Directory Assistance Database Service, per month | DBSOF | \$120.76 |
| | | |
| Direct Access to Directory Assistance Service (DADAS) | | |
| Direct Access to Directory Assistance Service, per month | DBSDS | \$7,235.01 |
| Direct Access to Directory Assistance Service, per query | DBSDA | \$0.0052 |
| Direct Access to Directory Assistance Service, svc estab charge | DBSDE | |
| NRC | DBSDE | \$1,186.94 |
| NRC - Disconnect | DBSDE | NA |
| NRC - Incremental Charge Manual Service Order - 1st | SOMAN | NA |
| | | |
| AIN (Note 4) | | |
| AIN, per message | CAM | NA |
| AIN - BellSouth AIN SMS Access Service | CAM | |
| Service Establishment Charge, per state, initial set-up | | |
| NRC | CAMSE | NA |
| NRC - Disconnect | CAMSE | NA |
| Port Connection - Dial/Shared Access | | |
| NRC | CAMDP | NA |
| NRC - Disconnect | CAMDP | NA |
| Port Connection - ISDN Access | | |
| NRC | CAM1P | NA |
| NRC - Disconnect | CAM1P | NA |
| User ID Codes - per User ID Code | | |
| NRC | CAMAU | NA |
| NRC - Disconnect | CAMAU | NA |
| Security Card per User ID Code, initial or replacement | | |
| NRC | CAMRC | NA |
| NRC - Disconnect | CAMRC | NA |
| Storage, per unit (100Kb) | N/A | NA |
| Session per minute | N/A | NA |
| C0. Performed Session, per minute | | NA |
| AIN - BellSouth AIN Toolkit Service | | |
| AIN, Service Creation Tools | CAMBP | NA |
| Service Establishment Charge, per state, initial set-up | | |
| NRC | BAPSC | NA |
| NRC - Disconnect | BAPSC | NA |
| Training Session, per customer | | |
| NRC | BAPVX | NA |
| NRC - Disconnect | BAPVX | NA |
| Trigger Access Charge, per trigger, per DN, Term. Attempt | | |
| NRC | BAPTT | NA |
| NRC - Disconnect | BAPTT | NA |
| Trigger Access Charge, per trigger per DN, Off-Hook Delay | | |
| NRC | BAPTD | NA |
| NRC - Disconnect | BAPTD | NA |
| Trigger Access Charge, per trigger, per DN, Off-Hook Immediate | | |
| NRC | BAPTM | NA |
| NRC - Disconnect | BAPTM | NA |
| Trigger Access Charge, per trigger, per DN, 10-Digit PODP | | |
| NRC | BAPTO | NA |
| NRC - Disconnect | BAPTO | NA |
| Trigger Access Charge, per trigger, per DN, CDP | | |
| NRC | BAPTC | NA |
| NRC - Disconnect | BAPTC | NA |
| Trigger Access Charge, per trigger, per DN, Feature Code | | |

BELLSOUTH/ADELPHIA RATES
NETWORK ELEMENTS
AND OTHER SERVICES

| DESCRIPTION | | KY |
|---|-------|-------------------|
| NRC | BAPTF | NA |
| NRC - Disconnect | BAPTF | NA |
| Query Charge, per query | | NA |
| Type 1 Node Charge, per AIN Toolkit Subscription, per node, per query | | NA |
| SCP Storage Charge, per SMS Access Acct, per 100 Kb | | |
| | N/A | NA |
| Monthly Report - per AIN Toolkit Service Subscription | | |
| | BAPMS | NA |
| NRC | BAPMS | NA |
| NRC - Disconnect | BAPMS | NA |
| Special Study - per AIN Toolkit Service Subscription | | |
| | BAPLS | NA |
| NRC | BAPLS | NA |
| NRC - Disconnect | BAPLS | NA |
| Call Event Report - per AIN Toolkit Service Subscription | | |
| | BAPDS | NA |
| NRC | BAPDS | NA |
| NRC - Disconnect | BAPDS | NA |
| Call Event special Study - per AIN Toolkit Service Subscription | | |
| | BAPES | NA |
| NRC | BAPES | NA |
| NRC - Disconnect | BAPES | NA |
| CALLING NAME (CNAM) QUERY SERVICE | | |
| CNAM (Database Owner), Per Query | | |
| | N/A | \$0.016 |
| CNAM (Non-Database Owner), Per Query * | | |
| | N/A | \$0.01 |
| NRC, applicable when CLEC-1 uses the Character Based User Interface (CHUI) | N/A | \$595.00 |
| * Volume and term arrangements are also available. | | |
| SELECTIVE ROUTING (Note 5) | | |
| Per Line or PBX Trunk, each | | |
| | | \$10.00 (Interim) |
| NRC | | NA |
| Customized routing per unique line class code, per request, per switch | | |
| NRC | USRCR | \$229.65 |
| NRC - Incremental Charge - Manual Service Order | | NA |
| VIRTUAL COLLOCATION | | |
| NRC - Virtual Collocation - Application Cost - Manual | TBD | NA |
| NRC - Virtual Collocation - Cable Installation Cost per Cable - Manual | TBD | NA |
| RC - Virtual Collocation - Floor space per square feet | TBD | NA |
| RC - Virtual Collocation - Floor space power, per ampere | TBD | NA |
| RC - Virtual Collocation - Cable support structure, per entrance cable | TBD | NA |
| 2-wire Cross-Connect | | |
| RC | UEAC2 | \$0.31 |
| NRC - 1st | UEAC2 | \$54.21 |
| NRC - Add'l | UEAC2 | \$51.07 |
| NRC - 1st - Manual Service Order | TBD | NA |
| NRC - Add'l - Manual Service Order | TBD | NA |
| NRC - Disconnect - 1st | UEAC2 | NA |
| NRC - Disconnect - Add'l | UEAC2 | NA |
| 4-wire Cross-Connect | | |
| RC | UEAC4 | \$0.62 |
| NRC - 1st | UEAC4 | \$54.23 |
| NRC - Add'l | UEAC4 | \$50.96 |
| NRC - 1st - Manual Service Order | TBD | NA |
| NRC - Add'l - Manual Service Order | TBD | NA |
| NRC - Disconnect - 1st | UEAC4 | NA |
| NRC - Disconnect - Add'l | UEAC4 | NA |
| 2-fiber Cross-Connect | | |
| RC | CNC2F | \$15.64 |

BELLSOUTH/ADELPHIA RATES
NETWORK ELEMENTS
AND OTHER SERVICES

| DESCRIPTION | | | KY |
|------------------------------|--|-------|---------------|
| | NRC - 1st | CNC2F | \$41.56 |
| | NRC - Add'l | CNC2F | \$29.82 |
| | NRC - Disconnect - 1st | CNC2F | NA |
| | NRC - Disconnect - Add'l | CNC2F | NA |
| 4-fiber Cross-Connect | | | |
| | RC | CNC4F | \$28.11 |
| | NRC - 1st | CNC4F | \$50.53 |
| | NRC - Add'l | CNC4F | \$38.78 |
| | NRC - Disconnect - 1st | CNC4F | NA |
| | NRC - Disconnect - Add'l | CNC4F | NA |
| DS1 Cross-Connects | | | |
| | RC | TBD | NA |
| | NRC - 1st | TBD | NA |
| | NRC - Add'l | TBD | NA |
| | NRC - Manual Service Order - 1st | TBD | NA |
| | NRC - Manual Service Order - Add'l | TBD | NA |
| DS3 Cross-Connects | | | |
| | RC | TBD | NA |
| | NRC - 1st | TBD | NA |
| | NRC - Add'l | TBD | NA |
| | NRC - Manual Service Order - 1st | TBD | NA |
| | NRC - Manual Service Order - Add'l | TBD | NA |
| E&M Signaling | | | |
| | DID Trunk Termination for Combination Trunks with Call Transfer, via BellSouth MegaLink Service into a Digital Central Office | | |
| | Trunk Side Termination for Dedicated Group of 24 circuits - each - Recurring | WWWDO | \$360.00 |
| | Non-Recurring - 1st and Add'l | WWWDO | \$325.00 |
| | DID Trunk Termination, each Combination Trunk with Call Transfer - Per Trunk Termination, per Channel - Recurring | | WOODH \$24.00 |
| | Non-Recurring - 1st and Add'l | WOODH | \$7.00 |
| | Service Establishment Charge - NRC | WGGVF | \$225.00 |
| | If no rate is identified in the contract, the rate for the specific service or function will be as set forth in applicable BellSouth tariff or as negotiated by the parties upon request by either party. | | |
| EXPEDITE CHARGES | | | |
| | Expedite Charge, per service order | SOCSW | \$295.00 |
| | If no rate is identified in the contract, the rate for the specific service or function will be as set forth in applicable BellSouth tariff or as negotiated by the parties upon request by either party. | | |
| | 1 BellSouth and CLEC shall negotiate rates for this offering. If agreement is not reached within sixty (60) days of the Effective Date, either party may petition the Florida PSC to settle the disputed charge or charges. (FL) | | |
| | 2 This rate element is for those states w/o separate rates for 800 calls with 800 No. Delivery vs. POTS No. Delivery and calls with Optional Complex Features vs. w/o Optional Complex Features. | | |
| | 3 This charge is only applicable where signaling usage measurement or billing capability does not exist. | | |
| | 4 Prices for AIN to be determined upon development of mediation device. (TN) | | |
| | 5 Price for Line Class Codes for Selective Routing shall be determined by the TRA. (TN) | | |

Attachment 3
Network Interconnection

TABLE OF CONTENTS

1. Network Interconnection..... 3

2. Interconnection Trunking Architectures..... 7

3. Network Design And Management For Interconnection 14

4. Local Dialing Parity..... 16

5. Interconnection Compensation 17

6. Frame Relay Service 25

7. Operational Support Systems (OSS) Rates 28

Rates.....Exhibit A

Basic Architecture.....Exhibit B

One-Way Trunking Architecture.....Exhibit C

Two-Way Trunking Architecture.....Exhibit D

Supergroup Architecture.....Exhibit E

Network Interconnection

The Parties shall provide interconnection with each other's networks for the transmission and routing of telephone exchange service ("Local Traffic," as further defined in Section 6.1.1 of this Attachment, traffic destined to Internet Service Providers "ISP-bound Traffic," as further defined in Section 6.1.3 of this Attachment), and exchange access (IntraLATA Toll Traffic and Switched Access Traffic) on the following terms:

1. Network Interconnection

All negotiated rates, terms and conditions set forth in this Attachment pertain to the provision of network interconnection.

- 1.1 Interconnection is available to both Parties through: (1) delivery of a Party's facilities to a collocation arrangement or Fiber Meet arrangement as defined in this Agreement; or (2) interconnection via purchase of facilities from the other Party or third parties. Interconnection may be provided by the Parties at any technically feasible point. Requests to BellSouth for interconnection at points not specified herein may be made through the Bona Fide Request/New Business Request process set out in General Terms and Conditions.
- 1.2 Adelphia must establish, at a minimum, a single Point of Presence, Interface, and Interconnection with BellSouth within the LATA for the delivery of Adelphia's originated Local Traffic, ISP-bound Traffic, IntraLATA Toll Traffic and Adelphia Transit Traffic as defined in 6.9 and for Adelphia's receipt of Third Party Transit Traffic as defined in 6.9. If Adelphia chooses to interconnect at a single Point of Interconnection within a LATA, the interconnection must be at a BellSouth Access Tandem. Furthermore, Adelphia must establish Points of Interconnection at all BellSouth access and local tandems where Adelphia NXXs are "homed." A "Homing" arrangement is defined by a "Final" Trunk Group between the BellSouth Tandem and Adelphia Switch. A "Final" Trunk Group is the last choice telecommunications path between the Tandem and End Office switch. It is Adelphia's responsibility to enter its own NPA/NXX access and/or local tandem "homing" arrangements into the national Local Exchange Routing Guide (LERG) either directly or via a vendor.
- 1.2.1 In order for Adelphia to home its NPA/NXX(s) on a BellSouth Tandem, Adelphia's NPA/NXX(s) must be assigned to an Exchange Rate Center Area served by that BellSouth Tandem and as specified by BellSouth. The specified association between BellSouth Tandems and Exchange Rate Center Areas is defined in the Local Exchange Routing Guide (LERG) as it is revised from time to time.

- 1.3 A **Point of Presence (POP)** is the physical location (a structure where the environmental, power, air conditioning, etc. specifications for a Party's terminating equipment can be met) at which a Party establishes itself for obtaining access to the other Party's network. The POP is the physical location within which the Point of Interfaces occur.
- 1.4 A **Point of Interface** is the physical telecommunications interface between BellSouth and Adelphia's interconnection functions. It establishes the technical interface and point of operational responsibility. The primary function of the Point of Interface is to serve as the terminus for the interconnection service. The Point of Interface has the following main characteristics:
1. It is a cross-connect point to allow connection, disconnection, transfer or restoration of service.
 2. It is a point where BellSouth and Adelphia can verify and maintain specific performance objectives.
 3. It is specified according to the interface offered in the local interconnection agreement.
 4. The Parties provide their own equipment (CPE) to interface with the DS0, DS1, DS3, STS1 and/or OCn circuits on the customer premises.
- 1.5 The **Point of Interconnection** is the point at which the originating Party delivers its originated traffic to the terminating Party's first point of switching on the terminating Party's common (shared) network for call transport and termination. Points of Interconnection are available at either Access Tandems, Local Tandems, or End Offices as described in this Agreement. Adelphia's requested Point of Interconnection will also be used for the receipt and delivery of Transit Traffic at BellSouth Access and Local Tandems. Points of Interconnection established at the BellSouth Local Tandem apply only to Adelphia-originated Local Traffic, ISP-bound Traffic, and local originating and terminating Transit Traffic.
- 1.6 A minimum of one Point of Interface shall be established in each LATA in which Adelphia originates, terminates, or exchanges Local Traffic or ISP-bound Traffic and interconnects with BellSouth. The location of the initial Point of Interface shall be established by mutual agreement of the Parties. In selecting the initial Point of Interface, both Parties will act in good faith and select the point which is most efficient for both Parties. Each Party shall be responsible for engineering and maintaining the network on its side of the Point of Interface. Establishment of an initial Point of Interface will be initiated by written request and will be based on traffic volumes and patterns, facilities available, and other factors unique to the area. If the Parties are not able to reach mutual agreement on an initial Point of Interface within 30 calendar days of the date of the written request, the dispute will be escalated to the next level of management. The next level of management will meet as often as necessary to resolve the dispute. If, 30 calendar days after the

dispute has been escalated, the Parties are still unable to agree to an initial mutual Point of Interface, each Party will designate the initial Point of Interface for its originated traffic.

- 1.6.1 Additional Points of Interface in a particular LATA may be established by mutual agreement of the Parties. Absent mutual agreement, in order to establish additional Points of Interface in a LATA, the traffic between Adelphia and BellSouth at the proposed additional Point of Interface must exceed 8.9 million minutes of Local Traffic or ISP-bound Traffic per month for three consecutive months during the busy hour. Additionally, any end office to be designated as a Point of Interface must be more than 20 miles from an existing Point of Interface. BellSouth will not designate a Point of Interface at a Central Office where physical or virtual collocation space or BellSouth fiber connectivity is not available.

Upon written notification from the Party requesting the establishment of an additional Point of Interface, the receiving Party has 45 calendar days to analyze, respond to, and negotiate in good faith the establishment of and location of such Point of Interface. If the receiving Party disagrees that the traffic and mileage thresholds set forth herein have been met, then such Party may utilize the dispute resolution procedures set forth in Section 12 of the General Terms and Conditions of this Agreement.

- 1.6.2 Unless mutually agreed to, or unless the dispute resolution procedures set forth in 1.6.1 above are invoked, a Point of Interface will be operational within nine months of the written request as described in 1.6 or 1.6.1. If more than two requests for Points of Interface are received within a three month time frame for one LATA, the nine month interval will apply to the first two requests. For a third and fourth request in a given three month period for one LATA, such third and fourth Points of Interface will be operational within twelve months of the written request as described in 1.6 or 1.6.1. For a fifth or sixth request in a given three month period for one LATA, such fifth and sixth Points of Interface will be operational within eighteen months of the written request as described in 1.6 or 1.6.1. To the extent either Party requests more than six Points of Interface within a three month time frame for one LATA, the Parties will mutually agree to the interval that will apply to the seventh and subsequent requests. To the extent any additional Point of Interface is established, each Party will work cooperatively to transition to such additional Point of Interface without unnecessarily disrupting service to either Party.

- 1.7 The Parties shall make available to each other one-way and two-way trunks for the reciprocal exchange of combined Local Traffic, ISP-bound Traffic and IntraLATA Toll Traffic. Effective nine months after the date of last signature of this agreement, the Parties shall institute a bill and keep compensation plan under

which neither Party will charge the other Party recurring and nonrecurring charges associated with trunks and associated facilities for the exchange of traffic other than Transit Traffic. From the effective date of this agreement until the bill and keep arrangement for trunks and facilities described above is enacted, both Parties shall charge each other the trunk installation charges and facility charges set forth in Exhibit A to this Attachment. Each Party has the obligation to install the appropriate trunks and associated facilities on its respective side of the Point of Interface. Notwithstanding the foregoing, reciprocal compensation will be paid for the delivery of Local Traffic and ISP-bound Traffic in accordance with the terms of Section 6.1. Nothing in this Section 1.7 shall be deemed to eliminate or affect any lease-back arrangement where a Party, at its option and in lieu of installing facilities or trunks on its side of the Point of Interface, chooses to lease such facilities or trunks from the other Party for its originating traffic.

- 1.8 Both Parties, as appropriate, shall be compensated for the ordering of trunks and facilities for the exchange of Transit Traffic. The Parties agree that charges for such trunks and facilities are as set forth in Exhibit A to this Attachment.
- 1.9 Fiber Meet
- 1.9.1 **Fiber Meet** is an interconnection arrangement whereby the Parties physically interconnect their networks via an optical fiber interface (as opposed to an electrical interface) at which one Party's facilities, provisioning, and maintenance responsibility begins and the other Party's responsibility ends (i.e. Point of Interface).
- 1.9.2 If Adelphia elects to interconnect with BellSouth pursuant to a Fiber Meet, Adelphia and BellSouth shall jointly engineer and operate a Synchronous Optical Network ("SONET") transmission system by which they shall interconnect their transmission and routing of Local Traffic via a Local Channel facility at either the DS0, DS1, or DS3 level. The Parties shall work jointly to determine the specific transmission system. However, Adelphia's SONET transmission must be compatible with BellSouth's equipment in the BellSouth Interconnection Wire Center. The same vendor's equipment and software version must be used, and the Data Communications Channel (DCC) must be turned off.
- 1.9.3 BellSouth shall, wholly at its own expense, procure, install and maintain the agreed upon SONET equipment in the BellSouth Interconnection Wire Center ("BIWC").
- 1.9.4 Adelphia shall, wholly at its own expense, procure, install and maintain the agreed upon SONET equipment in the Adelphia Interconnection Wire Center ("Adelphia Wire Center").
- 1.9.5 BellSouth and Adelphia shall jointly designate a Point of Interface outside the BIWC as a Fiber Meet point, and shall make all necessary preparations to receive,

and to allow and enable Adelphia to deliver, fiber optic facilities into the Point of Interface with sufficient spare length to reach the fusion splice point at the Point of Interface. BellSouth shall, wholly at its own expense, procure, install, and maintain the fusion splicing point in the Point of Interface. A Common Language Location Identification ("CLLI") code will be established for each Point of Interface. The code established must be a building type code. All orders shall originate from the Point of Interface (i.e., Point of Interface to Adelphia, Point of Interface to BellSouth).

- 1.9.6 Adelphia shall deliver and maintain such fiber optic facilities wholly at its own expense. Upon verbal request by Adelphia, BellSouth shall allow Adelphia access to the Fiber Meet entry point for maintenance purposes as promptly as possible.
- 1.9.7 The Parties shall jointly coordinate and undertake maintenance of the SONET transmission system. Each Party shall be responsible for maintaining the components of their own SONET transmission system.
- 1.9.8 Each Party will be responsible for (i) providing its own transport facilities to the Fiber Meet, and (ii) the cost to build-out its facilities to such Fiber Meet.
- 1.9.9 Neither Party shall charge the other for its portion of the Fiber Meet facility used exclusively for non-transit Local Traffic (i.e. the Local Channel). Charges incurred for other services including dedicated transport facilities to the Point of Interconnection if applicable will apply. Charges for Switched and Special Access Services shall be billed in accordance with the applicable Access Service tariff (i.e. each Party's FCC or Commission filed and effective Interstate or Intrastate Access Services Tariff).

2. Interconnection Trunking Architectures

- 2.1 BellSouth and Adelphia shall establish interconnecting trunk groups and trunking configurations between networks including the establishment of one-way or two-way trunks in accordance with the following provisions set forth in this Agreement.
- 2.2 Any Adelphia interconnection request that (1) deviates from the standard trunking architectures as described in this Agreement, (2) affects traffic delivered to Adelphia from a BellSouth switch, and (3) requires special BellSouth switch translations and other network modifications will require Adelphia to submit a Bona Fide Request/New Business Request via the Bona Fide Request/New Business Request Process set forth in General Terms and Conditions.
- 2.3 Pursuant to Section 1.7 of this Attachment and until bill and keep on trunks and facilities is enacted:

(1) All terms and conditions, as well as charges, both non-recurring and recurring, associated with interconnecting trunk groups and facilities between BellSouth and Adelphia are set forth in Exhibit A. In the event there is not an applicable rate element in Exhibit A, the Parties shall be compensated at the provisioning Party's tariff rate for such element on an interim basis subject to true-up as set forth in Section 6.6.

(2) For two-way trunking that carries the Parties' Local Traffic, ISP-bound Traffic, and IntraLATA Toll Traffic only, excluding trunking that carries Transit Traffic, the Parties shall be compensated for the nonrecurring and recurring charges for trunks and DS1 facilities at 50% of the applicable rates as set forth in Exhibit A to this Attachment 3 for the services provided by each Party.

(3) Adelphia shall be responsible for ordering and paying for any two-way trunking for its Local Traffic, ISP-bound Traffic and IntraLATA Toll Traffic if it utilizes such trunks unidirectionally

2.3.1 Throughout the term of this Agreement, Adelphia shall be responsible for ordering and paying for any two-way trunks carrying Transit Traffic.

2.4 Switched Access Traffic will be delivered to and by IXCs based on Adelphia's NXX Access Tandem homing arrangement as specified by Adelphia in the national Local Exchange Routing Guide (LERG).

2.5 All trunk groups will be provisioned as Signaling System 7 (SS7) capable where technically feasible. If SS7 is not technically feasible multi-frequency (MF) protocol signaling shall be used.

2.6 In cases where Adelphia is also an IXC, the IXC's Feature Group D (FG D) trunking must remain separate from the local interconnection trunking.

2.7 Two-Way Trunking Requirements:

The following requirements apply to two-way trunking that carries the Parties Local Traffic and IntraLATA Toll Traffic.

1. Adelphia will initiate two-way trunk request. The use of and quantity of two way trunking shall be mutually agreed upon and shall be jointly provisioned.
2. The Point of Interface will be located at a mutually agreed location or point. If the Parties cannot mutually agree to a Point of Interface, BellSouth shall designate the Point of Interface. If Adelphia disagrees with BellSouth's designation, Adelphia may elect to have each Party establish its own Point of Interface in accordance with Section 1.6 and 1.6.1 and order one-way trunks.

3. BellSouth and Adelphia will jointly review the trunk forecast, as needed, on a periodic basis, or at least every six (6) months.
4. Adelphia will order trunks using access service request (ASR) process in place for Local Interconnection at any time for augments to existing trunk groups and for new trunk groups, after the joint planning meeting takes place between the Parties.
5. BellSouth and Adelphia must agree on traffic engineering parameters that will be used in the engineering of the trunk groups.
6. BellSouth and Adelphia must agree to meet and resolve service-affecting situations in a timely manner. This contact will normally be made through the Account Team.
7. Establishing a two-way trunk group does not preclude BellSouth or Adelphia from adding one-way trunk groups within the same Local Calling Area.
8. For technical reasons, two-way trunk groups may not be ordered to a BellSouth DMS100 Local Tandem or DMS100 End Office.
9. BellSouth will be responsible for the installation and maintenance of its trunks and facilities to the mutually agreed Point of Interface, and Adelphia will be responsible for the installation and maintenance of its trunks and facilities to the mutually agreed to Point of Interface.

2.8 BellSouth Access Tandem Interconnection Architectures

2.8.1 BellSouth Access Tandem Interconnection provides intratandem access to subtending end offices. BellSouth Multiple Tandem Access (MTA), described later in this Agreement, may be ordered using any of the following access tandem architectures.

2.8.2 Basic Architecture

2.8.2.1 In this architecture, Adelphia's originating Local Traffic and IntraLATA Toll Traffic and originating and terminating Transit Traffic is transported on a single two-way trunk group between Adelphia and BellSouth access tandem(s) within a LATA. This group carries intratandem Transit Traffic between Adelphia and Independent Companies, Interexchange Carriers, other CLECs and other network providers with which Adelphia desires interconnection and has the proper contractual arrangements, where required. This group also carries Adelphia originated intertandem traffic transiting a single BellSouth access tandem destined to third party tandems such as an Independent Company tandem or other CLEC tandem. BellSouth originated Local Traffic and IntraLATA Toll Traffic is transported on a single one-way trunk group terminating to the Point of Interface for BellSouth originated traffic. The Two-way Trunking Requirements described

in this Attachment do not apply to this architecture. Other trunk groups for operator services, directory assistance, emergency services and intercept may be established if required. The LERG should be referenced for current routing and tandem serving arrangements. The Basic Architecture is illustrated in Exhibit B.

2.8.3 One-Way Trunking Architecture

2.8.3.1 In this architecture, the Parties interconnect using two one-way trunk groups. One one-way trunk group carries Adelphia-originated Local Traffic and IntraLATA Toll Traffic destined for BellSouth end-users. The other one-way trunk group carries BellSouth-originated Local Traffic and IntraLATA Toll Traffic destined for Adelphia end-users. A third two-way trunk group is established for Adelphia's originating and terminating Transit Traffic. This two-way trunk group carries intratandem Transit Traffic between Adelphia and Independent Companies, Interexchange Carriers, other CLECs and other network providers with which Adelphia desires interconnection and has the proper contractual arrangements, where required. This group also carries Adelphia originated intertandem traffic transiting a single BellSouth access tandem destined to third party tandems such as an Independent Company tandem or other CLEC tandem. Other trunk groups for operator services, directory assistance, emergency services and intercept may be established if required. The LERG should be referenced for current routing and tandem serving arrangements. The One-Way Trunking Architecture is illustrated in Exhibit C.

2.8.4 Two-Way Trunking Architecture

2.8.4.1 The Two-Way Trunking Architecture establishes one two-way trunk group to carry Local Traffic and IntraLATA Toll Traffic between Adelphia and BellSouth. To establish this architecture, Adelphia and BellSouth must meet the Two-way Trunking Requirements described in this Attachment. In addition, a two-way transit trunk group must be established for Adelphia's originating and terminating Transit Traffic. This group carries intratandem Transit Traffic between Adelphia and Independent Companies, Interexchange Carriers, other CLECs and other network providers with which Adelphia desires interconnection and has the proper contractual arrangements, where required. This group also carries Adelphia originated intertandem traffic transiting a single BellSouth access tandem destined to third party tandems such as an Independent Company tandem or other CLEC tandem. Other trunk groups for operator services, directory assistance, emergency services and intercept may be established if required. The LERG should be referenced for current routing and tandem serving arrangements. The Two-Way Trunking Architecture is illustrated in Exhibit D.

2.8.5 Supergroup Architecture

- 2.8.5.1 In the Supergroup Architecture, the Parties Local Traffic and IntraLATA Toll Traffic and Adelphia's Transit Traffic is exchanged on a single two-way trunk group between Adelphia and BellSouth. To establish this architecture, Adelphia and BellSouth must meet the Two-way Trunking Requirements described in this Attachment. This group carries intratandem Transit Traffic between Adelphia and Independent Companies, Interexchange Carriers, other CLECs and other network providers with which Adelphia desires interconnection and has the proper contractual arrangements, where required. This group also carries Adelphia originated intertandem traffic transiting a single BellSouth access tandem destined to third party tandems such as an Independent Company tandem or other CLEC tandem. Other trunk groups for operator services, directory assistance, emergency services and intercept may be established if required. The LERG should be referenced for current routing and tandem serving arrangements. The Supergroup Architecture is illustrated in Exhibit E.
- 2.9 BellSouth Multiple Tandem Access (MTA)
- 2.9.1 BellSouth **Multiple Tandem Access (MTA)** provides for LATA wide BellSouth transport and termination of Adelphia-originated Local Traffic, ISP-bound Traffic, and IntraLATA Toll Traffic, that is transported by BellSouth, by establishing a Point of Interconnection at a BellSouth access tandem with routing through multiple BellSouth access tandems as required. However, Adelphia must still establish Points of Interconnection at all BellSouth access tandems where Adelphia NXXs are "homed". If Adelphia does not have NXXs homed at a BellSouth access tandem within a LATA and elects not to establish Points of Interconnection at such BellSouth access tandem, Adelphia can order MTA in each BellSouth access tandem within the LATA where it does have a Point of Interconnection and BellSouth will terminate traffic to end-users served through those BellSouth access tandems where Adelphia does not have a Point of Interconnection. MTA shall be provisioned in accordance with BellSouth's Ordering Guidelines.
- 2.9.2 MTA does not include Switched Access Traffic that transits the BellSouth network to an Interexchange Carrier (IXC). Switched Access Traffic will be delivered to and by IXCs based on Adelphia's NXX Access Tandem homing arrangement as specified by Adelphia in the national Local Exchange Routing Guide (LERG).
- 2.9.3 For Adelphia-originated Local Traffic, ISP-bound Traffic and IntraLATA Toll Traffic that BellSouth transports but is destined for termination by a third Party network (Transit Traffic), BellSouth MTA is required if multiple BellSouth access tandems are necessary to deliver the call to the third Party network.
- 2.9.4 With MTA, for the delivery of Adelphia-originated Local Traffic, ISP-bound Traffic, and IntraLATA Toll Traffic, Adelphia will be assessed charges as specified in the pricing exhibit to this Agreement for the additional transport and tandem

switching on an elemental basis in addition to the reciprocal compensation rate to which the parties have agreed in Section 6.1.2. Notwithstanding the foregoing, in the situation of tandem exhaust at any particular tandem, where the parties choose MTA as an alternative routing plan, the Parties will negotiate appropriate rates, terms and conditions for MTA.

- 2.9.5 To the extent Adelphia does not purchase MTA in a calling area that has multiple access tandems serving the calling area as defined by BellSouth, Adelphia must establish Points of Interconnection to every access tandem in the calling area in order to serve the entire calling area. To the extent Adelphia does not purchase MTA and provides intraLATA toll service to its customers, it may be necessary for it to establish a Point of Interconnection to additional BellSouth access tandems that serve end offices outside the local calling area. To the extent Adelphia routes its traffic in such a way that utilizes BellSouth's MTA service without properly ordering MTA service, Adelphia agrees to pay BellSouth the associated transport and termination charges.
- 2.9.6 Nothing in this Section 2.9 affects the obligation of BellSouth to deliver BellSouth-originated Local Traffic, ISP-bound Traffic, and IntraLATA Toll Traffic to the Point(s) of Interconnection established pursuant to Section 1.5.
- 2.10 BellSouth End Office Interconnection
- 2.10.1 Adelphia may establish Points of Interconnection at BellSouth end offices for the delivery of Adelphia originated Local Traffic, ISP-bound Traffic and IntraLATA Toll Traffic destined for BellSouth end-users served by that end-office.
- 2.10.2 When end office trunking is ordered by BellSouth to deliver BellSouth originated traffic to Adelphia, BellSouth will provide overflow routing through BellSouth tandems consistent with how BellSouth overflows its traffic. The overflow will be based on the homing arrangements Adelphia displays in the LERG. Likewise, if Adelphia interconnects to a BellSouth end office for delivery of Adelphia originated traffic, Adelphia will overflow the traffic through the BellSouth tandems based on the BellSouth homing arrangements shown in the LERG.
- 2.10.3 The Parties shall utilize direct end office trunking under the following conditions:
- (1) Tandem Exhaust - If a tandem through which the Parties are interconnected is unable to, or is forecasted to be unable to support additional traffic loads for any period of time, the Parties will mutually agree on an end office trunking plan that will alleviate the tandem capacity shortage and ensure completion of traffic between Adelphia and BellSouth's subscribers.
 - (2) Traffic Volume -To the extent either Party has the capability to measure the amount of traffic between a Adelphia switching center and a BellSouth end

office, either Party shall install and retain direct end office trunking sufficient to handle actual or reasonably forecasted traffic volumes, whichever is greater, between a Adelphia switching center and a BellSouth end office where the traffic exceeds or is forecasted to exceed two DS1s of Local Traffic per month. Either Party will install additional capacity between such points when overflow traffic between Adelphia's switching center and BellSouth's end office exceeds or is forecasted to exceed a single DS1 of Local Traffic per month. In the case of one way trunking, additional trunking shall only be required by the Party whose trunking has achieved the preceding usage threshold.

- (3) Mutual Agreement - The Parties may install direct end office trunking upon mutual agreement in the absence of conditions (1) or (2) above and agreement will not unreasonably be withheld.

2.11 Local Tandem Interconnection.

2.11.1 This interconnection arrangement allows Adelphia to establish a Point of Interconnection at BellSouth local tandems for: (1) the delivery of Adelphia-originated Local Traffic and ISP-bound Traffic transported and terminated by BellSouth to BellSouth end offices within the local calling area as defined in BellSouth's General Subscriber Services Tariff (GSST), section A3 served by those BellSouth local tandems, and (2) for local Transit Traffic transported by BellSouth for third party network providers who have also established Points of Interconnection at those BellSouth local tandems.

2.11.2 When a specified local calling area is served by more than one BellSouth local tandem, Adelphia must designate a "home" local tandem for each of its assigned NPA/NXXs and establish trunk connections to such local tandems. Additionally, Adelphia may choose to establish a Point of Interconnection at the BellSouth local tandems where it has no codes homing but is not required to do so. Adelphia may deliver Local Traffic to a "home" BellSouth local tandem that is destined for other BellSouth or third party network provider end offices subtending other BellSouth local tandems in the same local calling area where Adelphia does not choose to establish a Point of Interconnection. It is Adelphia's responsibility to enter its own NPA/NXX local tandem homing arrangements into the Local Exchange Routing Guide (LERG) either directly or via a vendor in order for other third party network providers to determine appropriate traffic routing to Adelphia's codes. Likewise, Adelphia shall obtain its routing information from the LERG.

2.11.3 Notwithstanding establishing Points of Interconnection to BellSouth's local tandems, Adelphia must also establish Points of Interconnection to BellSouth access tandems within the LATA on which Adelphia has NPA/NXXs homed for the delivery of Interexchange Carrier Switched Access Traffic (SWA) and IntraLATA Toll Traffic, and traffic to Type 2A CMRS connections located at the access tandems. BellSouth shall not switch SWA traffic through more than one

BellSouth access tandem. SWA, Type 2A CMRS or toll traffic routed to the local tandem in error will not be backhauled to the BellSouth access tandem for completion. (Type 2A CMRS interconnection is defined in BellSouth's A35 General Subscriber Services Tariff.)

- 2.11.4 BellSouth's provisioning of local tandem interconnection assumes that Adelphia has executed, where required, the necessary local interconnection agreements with the other third party network providers subtending those local tandems.

3. Network Design And Management For Interconnection

- 3.1 Network Management and Changes. Both Parties will work cooperatively with each other to install and maintain the most effective and reliable interconnected telecommunications networks, including but not limited to, the exchange of toll-free maintenance contact numbers and escalation procedures. Both Parties agree to provide public notice of changes in the information necessary for the transmission and routing of services using its local exchange facilities or networks, as well as of any other changes that would affect the interoperability of those facilities and networks.
- 3.2 Interconnection Technical Standards. The interconnection of all networks will be based upon accepted industry/national guidelines for transmission standards and traffic blocking criteria. Interconnecting facilities shall conform, at a minimum, to the telecommunications industry standard of DS-1 pursuant to Bellcore Standard No. TR-NWT-00499. Signal transfer point, Signaling System 7 ("SS7") connectivity is required at each interconnection point. BellSouth will provide out-of-band signaling using Common Channel Signaling Access Capability where technically and economically feasible, in accordance with the technical specifications set forth in the BellSouth Guidelines to Technical Publication, TR-TSV-000905. Facilities of each Party shall provide the necessary on-hook, off-hook answer and disconnect supervision and shall hand off calling number ID (Calling Party Number) when technically feasible.
- 3.3 Quality of Interconnection. The local interconnection for the transmission and routing of telephone exchange service and exchange access that each Party provides to each other will be at least equal in quality to what it provides to itself and any subsidiary or affiliate or to any other Party to which each Party provides local interconnection.
- 3.4 Network Management Controls. Both Parties will work cooperatively with each other to apply sound network management principles by invoking appropriate network management controls (e.g., call gapping) to alleviate or prevent network congestion.

- 3.5 Common Channel Signaling. Both Parties will provide LEC-to-LEC Common Channel Signaling (“CCS”) to each other, where available, in conjunction with all traffic in order to enable full interoperability of CLASS features and functions except for call return. All CCS signaling parameters will be provided, including automatic number identification (“ANI”), originating line information (“OLI”) calling company category, charge number, etc. All privacy indicators will be honored, and each Party will cooperate with each other on the exchange of Transactional Capabilities Application Part (“TCAP”) messages to facilitate full interoperability of CCS-based features between the respective networks. Neither Party shall alter the CCS parameters, or be a party to altering such parameters, or knowingly pass CCS parameters that have been altered in order to circumvent appropriate interconnection charges.
- 3.6 Signaling Call Information. BellSouth and Adelphia will send and receive 10 digits for Local Traffic. Additionally, BellSouth and Adelphia will exchange the proper call information, i.e. originated call company number and destination call company number, CIC, and OZZ, including all proper translations for routing between networks and any information necessary for billing.
- 3.7 Forecasting Requirements. The Parties shall exchange technical descriptions and forecasts of their interconnection and traffic requirements in sufficient detail necessary to establish the interconnections required to assure traffic completion to and from all customers in their respective designated service areas. In order for the Parties to provide as accurate reciprocal trunking forecasts as possible to each other, each Party must timely inform the other Party of any known or anticipated events that may affect reciprocal trunking requirements. If either Party is unable to provide such information, The Parties shall provide reciprocal trunking forecasts based only on existing trunk group growth and annual estimated percentage of subscriber line growth.
- 3.7.1 Both Parties shall meet every six months or at otherwise mutually agreeable intervals for the purpose of exchanging non-binding forecasts of its traffic and volume requirements for the interconnection and network elements provided under this Agreement, in the form and in such detail as agreed by the Parties. The Parties agree that each forecast provided under this Section shall be deemed “Confidential Information” in the General Terms and Conditions – Part A of this Agreement.
- 3.7.2 The trunk forecast should include trunk requirements for all of the interconnecting trunk groups for the current year plus the next future year. The forecast meeting between the two companies may be a face-to-face meeting, video conference or audio conference. It may be held regionally or geographically. Ideally, these forecast meetings should be held at least semi-annually, or more often if the forecast is no longer usable. Updates to a forecast or portions thereof should be made whenever the Party providing the forecast deems that the latest trunk requirements exceed the original quantities by 24 trunks or 10%, whichever is

greater. Either Party should notify the other Party if they have measurements indicating that a trunk group is exceeding its designed call carrying capacity and is impacting other trunk groups in the network. Also, either Party should notify the other Party if they know of situations in which the traffic load is expected to increase significantly and thus affect the interconnecting trunk requirements as well as the trunk requirements within the other Party's network. The Parties agree that the forecast information provided under this Section shall be deemed "Confidential Information" as set forth in the General Terms and Conditions of this Agreement.

3.7.3 For a non-binding trunk forecast, agreement between the two Parties on the trunk quantities and the timeframe of those trunks does not imply any liability for failure to perform if the trunks are not available for use at the required time.

3.7.4 Upon written request from Adelphia, BellSouth shall provide Adelphia written confirmation that it has received Adelphia's forecasts and considered such information in BellSouth's network planning. Trunking forecasts shall include:

- (i) the use of Common Language Locator Identifier (LLI-MSG), which is described in BellCore documents BR 795-100-100 and BIR 795-400-100; and
- (ii) a description of major network projects anticipated for the following six (6) months that could affect the other Party. Major network projects including trunking or network rearrangements; anticipated tandem exhaust; anticipated office exhaust. This planning will include the issues of network capacity, forecasting, and compensation calculation, where appropriate.

If the forecasts vary significantly, the Parties shall meet to review and reconcile such forecasts.

3.7.5 BellSouth shall provide notice to Adelphia of any network changes pursuant to FCC Rules 51.325-51.335.

4. Parity in Ordering And Provisioning

Each Party shall provide interconnection ordering and provisioning services to the other Party that are equal to the ordering and provisioning services the Parties provide themselves, their affiliates and third parties. Detailed procedures for ordering and provisioning BellSouth interconnection services are set forth in the *BellSouth Call Transport & Termination Service For Facility Based CLECs section of the Facility Based CLEC Activation Requirements Customer Guide*.

5. Local Dialing Parity

- 5.1 BellSouth and Adelphia shall provide local and toll dialing parity to each other with no unreasonable dialing delays. Dialing parity shall be provided for all originating telecommunications services that require dialing to route a call. BellSouth and Adelphia shall permit similarly situated telephone exchange service end users to dial the same number of digits to make a local telephone call notwithstanding the identity of the end user's or the called party's telecommunications service provider.

6. Interconnection Compensation

- 6.1 Compensation for Call Transportation and Termination for Local Traffic and Inter-Carrier Compensation for ISP-Bound Traffic.

- 6.1.1 Local Traffic is defined as any telephone call that originates in one exchange and terminates in either the same exchange, or other local calling area associated with the originating exchange as defined and specified in Section A3 of BellSouth's General Subscriber Service Tariff, except for those calls that are originated or terminated through switched access arrangements as established by the ruling regulatory body. Local Traffic does not include, and the Parties shall not pay reciprocal compensation for, calls where a Party willfully sets up a call, or colludes with a third party to set up a call, to the other Party's network for the primary purpose of receiving reciprocal compensation, and not for the purpose of providing a Telecommunications Service to an End User in good faith.

- 6.1.2 Nothing in this Agreement shall be construed to limit each Party's ability to designate the areas within which the Party's Customers may make calls which that Party rates as "local" in its Customer Tariffs.

Subject to the Parties agreement to the terms of Sections 1.5 through 1.8, and Sections 2.9 through 2.9.6, the Parties will compensate each other on a mutual and reciprocal basis for the transport and termination of Local Traffic at the following rates:

| | |
|---------------------------|------------------|
| Effective Date – 12/31/00 | \$.00200 per MOU |
| 1/1/01 – 12/31/01 | \$.00175 per MOU |
| 1/1/02 – 12/31/02 | \$.00150 per MOU |

The Parties recognize and agree that they negotiated these annual rates together as a complete rate structure to apply over the full term of this Agreement and that the Parties would not have mutually agreed to accept a single annual rate in any single year. Nothing in this Paragraph shall limit Adelphia's rights pursuant to Paragraph 6.1.3.3.

- 6.1.3 The Parties have been unable to agree upon whether dial up calls to Information Service Providers ("ISPs") should be considered Local Traffic for purposes of this

Agreement. Dial-up Calls are defined as calls to an ISP that are dialed by using a local dialing pattern (7 or 10 digits) by the calling party to an ISP server physically located in the local calling area (referred to as “ISP-bound Traffic”). However, without prejudice to either Party’s position concerning the application of reciprocal compensation to ISP-bound Traffic, the Parties agree for purposes of this Agreement only to compensate each other for the delivery of ISP-bound Traffic at the same per minute of use rates set forth in Paragraph 6.1.2. It is expressly understood and agreed that this inter-carrier compensation mechanism for ISP-bound Traffic is being established: (1) in consideration for a waiver and release by each party for any and all claims for reciprocal compensation for ISP-bound Traffic exchanged between the parties prior to expiration of their predecessor interconnection agreements, which is hereby given; and (2) subject to the terms and conditions in section 6.1.4.

- 6.1.3.1 The Parties recognize and agree that the FCC, courts of competent jurisdiction, or state commissions with jurisdiction over the Parties will issue subsequent decisions on ISP-bound Traffic (“Subsequent Decisions”). Notwithstanding any provision in this Agreement to the contrary, the inter-carrier compensation mechanism established in Section 6.1.3 shall continue at the rates set forth in Section 6.1.2 for the full term of this Agreement without regard to such Subsequent Decisions, except as provided for in Sections 6.1.3.2 and 6.1.3.3.
- 6.1.3.2 To the extent such Subsequent Decisions render the inter-carrier compensation mechanism for ISP-bound Traffic set forth in Section 6.1.3 in violation of applicable federal or state law, the Parties agree to amend this Agreement within thirty (30) days of the effective date of any such Subsequent Decision to conform the inter-carrier compensation mechanism set forth in Section 6.1.3 with such Subsequent Decision. In the event of such an amendment, there will be no true-up for compensation paid prior to the amendment.
- 6.1.3.3 Nothing herein shall preclude Adelphia from exercising its rights under this Agreement or Section 252(i) of the 1996 Act and applicable FCC regulations to elect rates, terms, and conditions with respect to the payment of reciprocal compensation from any other approved interconnection agreement executed by BellSouth under which BellSouth is paying reciprocal compensation or other form of intercarrier compensation for ISP-bound Traffic other than on an interim basis. The Parties recognize and agree that this provision is intended to ensure that Adelphia is treated in the same manner with respect to the payment of compensation for ISP-bound Traffic as the competing local exchange carrier from whose interconnection agreement Adelphia seeks to elect rates, terms, and conditions. Accordingly, Adelphia agrees that it will not seek to elect compensation rates, terms, or conditions from another interconnection agreement unless those rates, terms, and conditions apply to ISP-bound Traffic (other than on an interim basis), either by the express terms of that agreement, by voluntary action by BellSouth, or pursuant to an effective state commission or court order.

- 6.1.4 The Parties recognize and agree that the compensation for the transport and termination of Local Traffic set forth in Section 6.1.2 and the inter-carrier compensation mechanism for ISP-bound Traffic set forth in Section 6.1.3 are intended to allow each Party to recover costs associated with such traffic.
- 6.1.5 Neither Party shall represent Switched Access Traffic as Local Traffic for purposes of payment of reciprocal compensation.
- 6.1.6 The Parties have been unable to agree as to the appropriate compensation for calls which originate in a Local Calling Area and terminate to a physical location outside of that Local Calling Area but to a number assigned to a rate center within that Local Calling Area (hereafter, Virtual NXX traffic). However, without prejudice to either Party's position concerning the application of reciprocal compensation or access charges to Virtual NXX traffic, the Parties agree for purposes of this Agreement only, and as an integral portion of the consideration for the Parties' resolution of the terms and conditions in Sections 1.5 through 1.8, 2.9 through 2.9.6, 6.1 through 6.1.5, and 6.8.1 and on an interim basis until the FCC issues an Order addressing the issue of Virtual NXX traffic, neither Party shall bill the other reciprocal compensation, intercarrier compensation or switched access in connection with the exchange of any virtual NXX traffic as described in the first sentence of this paragraph. Once there is an Effective FCC Order addressing the issue of Virtual NXX traffic, the Parties agree to amend this Interconnection Agreement to comply with the Order on a prospective basis only within 30 days of either Party's written request. No "true-up" shall be required in connection with such an Effective Order.
- 6.1.6.1. At the time of entering into this agreement, BellSouth and Adelphia recognize that changes are necessary to Adelphia's billing system to allow it to bill in accordance with the provisions stated above. Adelphia agrees to implement the systems changes necessary on or before November 19, 2001 ("Implementation Period") or to notify BellSouth, on or before such date, that Adelphia is no longer terminating Virtual NXX traffic. During the Implementation Period, the bill and keep arrangement set forth herein shall apply to all Virtual NXX traffic as described in Section 6.1.6 above in every state covered by this agreement. However, to the extent Adelphia is unable to identify Virtual NXX traffic to BellSouth for Adelphia's operations in Kentucky, Louisiana, Tennessee and the Jacksonville, Florida LATA (the "Transition Areas"), and where BellSouth can determine with specificity that certain individual telephone numbers in an Adelphia NPA/NXX in the Transition Areas are terminating Virtual NXX traffic, then BellSouth may adjust the compensation paid to Adelphia in accordance with the compensation arrangement stated above, but only with respect to compensation due for traffic terminated to those identified numbers. BellSouth shall make appropriate adjustments once Adelphia provides sufficient information for the Parties to

determine whether the traffic terminated to those specific numbers within an NPA/NXX is Local Traffic, ISP-bound Traffic, IntraLATA Toll Traffic, Transit Traffic or Virtual NXX traffic. Any Virtual NXX billing disputes will be resolved through billing dispute procedures as set forth in the Agreement.

- 6.2 Percent Local Use. Each Party will report to the other a Percentage Local Usage (“PLU”) factor for the reporting Party’s originating traffic. The PLU will be utilized by the terminating Party to determine the amount of Local Traffic and ISP-bound Traffic minutes to be billed to the originating Party. For purposes of developing the PLU, the originating Party shall consider all Local Traffic, ISP-bound Traffic, IntraLATA Toll Traffic and Switched Access Traffic, excluding Transit Traffic. By the first of January, April, July and October of each year, each Party shall provide a positive report updating the PLU. Requirements associated with PLU calculation and reporting shall be as set forth in BellSouth’s Percent Local Use Reporting Guidebook, as it is amended from time to time. Notwithstanding the foregoing, where the terminating Party has message recording technology that identifies the jurisdiction of traffic terminated as defined in this Agreement, such information, in lieu of the PLU factor, shall at the terminating Party’s sole discretion be utilized to determine the appropriate Local Traffic and ISP-bound Traffic usage compensation to be paid. Use of such messaging recording technology shall not relieve either Party of its obligation to provide a PLU factor as set forth in this Section. The audit provisions of Section 6.5 apply whether Local Traffic and ISP-bound Traffic minutes billed to the originating Party are determined through use of the PLU or message recording technology. The Parties recognize that there is a disagreement regarding the nature of ISP-bound traffic as stated in Section 6.1.3. Notwithstanding the foregoing, for purposes of this Agreement only and without prejudice to either Party’s position, the Parties agree to include minutes of use for ISP-bound Traffic as defined in Section 6.1.3 in the Percent Local Usage Factor.

The addresses for the receipt of PLU reports are:

Adelphia
CABS Manager
Main at Water Street
Coudersport, PA 16915

BellSouth
BellSouth Billing Manager
2300 North Lake Centre
Suite 415
Tucker, Georgia 30084

- 6.4 Percentage Interstate Usage. For Adelpia's combined Local Traffic, ISP-bound Traffic, IntraLATA Toll Traffic, and Switched Access Traffic terminated by BellSouth over the same facilities, Adelpia will be required to provide a projected Percentage Interstate Usage ("PIU") to BellSouth. All jurisdictional report requirements, rules and regulations for Interexchange Carriers specified in BellSouth's Intrastate Access Services Tariff will apply to Adelpia. After interstate and intrastate traffic percentages have been determined by use of PIU procedures, the PLU factor will be used for application and billing of local interconnection. Notwithstanding the foregoing, where the terminating Party has message recording technology that identifies the jurisdiction of traffic terminated as defined in this Agreement, such information, in lieu of the PIU and PLU factor, shall at the terminating Party's option be utilized to determine the appropriate Local Traffic and ISP-bound Traffic usage compensation to be paid.
- 6.5 Audits. On thirty (30) days written notice, each Party must provide the other the ability and opportunity to conduct an annual audit to ensure the proper billing of traffic. BellSouth and Adelpia shall retain records of call detail for a minimum of nine months from which a PLU and/or PIU can be ascertained. The audit shall be accomplished during normal business hours at an office designated by the Party being audited. Audit requests shall not be submitted more frequently than one (1) time per calendar year. Audits shall be performed by a mutually acceptable independent auditor paid for by the Party requesting the audit. The PLU and/or PIU shall be adjusted based upon the audit results and shall apply to the usage for the quarter the audit was completed, to the usage for the quarter prior to the completion of the audit, and to the usage for the two quarters following the completion of the audit. If, as a result of an audit, either Party is found to have overstated the PLU and/or PIU by twenty percentage points (20%) or more, that Party shall reimburse the auditing Party for the cost of the audit.
- 6.6 **Rate True-up**
- This section applies only to Tennessee and other rates that are interim or expressly subject to true-up under this attachment.
- 6.6.1 The interim prices for Unbundled Network Elements and Other Services and Local Interconnection shall be subject to true-up according to the following procedures:
- 6.6.2 The interim prices shall be trued-up, either up or down, based on final prices determined either by further agreement between the Parties, or by a final order (including any appeals) of the Commission which final order meets the criteria of Section 6.6.4 below. The Parties shall implement the true-up by comparing the actual volumes and demand for each item, together with interim prices for each item, with the final prices determined for each item. Each Party shall keep its own records upon which the true-up can be based, and any final payment from one

Party to the other shall be in an amount agreed upon by the Parties based on such records. In the event of any disagreement as between the records or the Parties regarding the amount of such true-up, the Parties agree that the body having jurisdiction over the matter shall be called upon to resolve such differences, or the Parties may mutually agree to submit the matter to the Dispute Resolution process in accordance with the provisions of Section 12 of the General Terms and Conditions and Attachment 1 of the Agreement.

6.6.3 The Parties may continue to negotiate toward final prices, but in the event that no such agreement is reached within nine (9) months, either Party may petition the Commission to resolve such disputes and to determine final prices for each item. Alternatively, upon mutual agreement, the Parties may submit the matter to the Dispute Resolution Process set forth in the General Terms and Conditions of the Agreement, so long as they file the resulting Agreement with the Commission as a “negotiated agreement” under Section 252(e) of the Act.

6.6.4 A final order of this Commission that forms the basis of a true-up shall be the final order as to prices based on appropriate cost studies, or potentially may be a final order in any other Commission proceeding which meets the following criteria:

- (a) BellSouth and CLEC is entitled to be a full Party to the proceeding; and
- (b) It shall apply the provisions of the federal Telecommunications Act of 1996, including but not limited to Section 252(d)(1) (which contains pricing standards) and all then-effective implementing rules and regulations.

6.7 Compensation for 8XX and IntraLATA Toll Traffic

6.7.1 IntraLATA Toll Traffic. IntraLATA Toll Traffic is defined as any telephone call that is not Local Traffic, ISP-bound Traffic as defined in Section 6.1.3, or Switched Access Traffic per this Agreement.

6.7.2 Compensation for IntraLATA Toll Traffic. For terminating its IntraLATA Toll Traffic on the other company’s network, the originating Party will pay the terminating Party the terminating Party’s current intrastate or interstate, whichever is appropriate, terminating switched access tariff rates as set forth in BellSouth’s or Adelphia’s Commission or FCC filed and effective Intrastate or Interstate Access Services Tariff. The appropriate charges will be determined by the routing of the call. If Adelphia is the BellSouth end user’s presubscribed interexchange carrier or if the BellSouth end user uses Adelphia as an interexchange carrier on a 101XXXX basis, BellSouth will charge Adelphia the appropriate BellSouth tariff charges for originating switched access services. Notwithstanding the foregoing, Virtual NXX traffic shall be compensated in accordance with the provisions of 6.1.6 above.

- 6.7.3 Compensation for 8XX Traffic. Each Party shall compensate the other pursuant to the appropriate switched access charges, including the database query charge as set forth in BellSouth's or Adelphia's Commission or FCC filed and effective intrastate or interstate switched access tariffs.
- 6.7.4 Records for 8XX Billing. Each Party will provide to the other the appropriate records necessary for billing intraLATA 8XX customers. The records provided will be in a standard EMI format for a fee of \$0.013 per record.
- 6.7.5 8XX Access Screening. BellSouth's provision of 8XX TFD to Adelphia requires interconnection from Adelphia to BellSouth 8XX SCP. Such interconnections shall be established pursuant to BellSouth's Common Channel Signaling Interconnection Guidelines and Bellcore's CCS Network Interface Specification document, TR-TSV-000905. Adelphia shall establish CCS7 interconnection at the BellSouth Local Signal Transfer Points serving the BellSouth 8XX SCPs that Adelphia desires to query. The terms and conditions for 8XX TFD are set out in BellSouth's Intrastate Access Services Tariff as amended.
- 6.8 Mutual Provision of Switched Access Service
- 6.8.1 Switched Access Traffic. Switched Access Traffic is defined as telephone calls requiring local transmission or switching services for the purpose of the origination or termination of Telephone Toll Service. Switched Access Traffic includes, but is not limited to, the following types of traffic: Feature Group A, Feature Group B, Feature Group C, Feature Group D, toll free access (e.g., 800/877/888), 900 access, and their successors. The Parties have been unable to agree as to whether Voice over Internet Protocol (VOIP) transmissions which cross local calling area boundaries constitute Switched Access Traffic. Notwithstanding the foregoing, and without waiving any rights with respect to either Party's position as to the jurisdictional nature of VOIP, the Parties agree to abide by any effective and applicable FCC rules and orders regarding the nature of such traffic and the compensation payable by the Parties for such traffic, if any; provided however, that any VOIP transmission which originates in one local calling area and terminates in another local calling area (i.e., the end-to-end points of the call), shall not be compensated as Local Traffic.
- 6.8.2 When Adelphia is subtending a BellSouth Access Tandem for receipt and delivery of Switched Access Traffic, BellSouth will provide an access service connection to or from an IXC. Each Party will provide its own access services to the IXC on a multi-bill, multi-tariff meet-point basis. Each Party will bill its own access services rates to the IXC with the exception of the interconnection charge. The interconnection charge, if applicable, will be billed by the Party providing the end office function. Each party will use the Multiple Exchange Carrier Access Billing (MECAB) system to establish meet point billing for all applicable traffic. Thirty (30)-day billing periods will be employed for these arrangements. The recording

Party agrees to provide to the initial billing Party, at no charge, the switched access detailed usage data within no more than sixty (60) days after the recording date. The initial billing Party will provide the switched access summary usage data to all subsequent billing Parties within 10 days of rendering the initial bill to the IXC. Each Party will notify the other when it is not feasible to meet these requirements so that the customers may be notified for any necessary revenue accrual associated with the significantly delayed recording or billing. As business requirements change data reporting requirements may be modified as necessary.

- 6.8.3 In the event that either Party fails to provide switched access detailed usage data to the other Party within ninety (90) days after the recording date and the receiving Party is unable to bill and/or collect access revenues due to the sending Party's failure to provide such data within said time period, then the Party failing to send the data as specified herein shall be liable to the other Party in an amount equal to the unbillable or uncollectible revenues. Each Party will provide complete documentation to the other to substantiate any claim of unbillable access revenues. In cases of documented unbillable access revenues, the Parties will reach a negotiated settlement regarding such lost revenues pursuant to the Dispute Resolution process set forth in Section 12 of the General Terms and Conditions.
- 6.8.4 Each Party will retain for a minimum period of sixty (60) days, access message detail sufficient to recreate any data which is lost or damaged by their company or any third party involved in processing or transporting data.
- 6.8.5 Each Party agrees to recreate the lost or damaged data within forty-eight (48) hours of notification by the other or by an authorized third party handling the data.
- 6.8.6 Each Party also agrees to process the recreated data within forty-eight (48) hours of receipt at its data processing center.
- 6.8.7 All claims should be filed with the other Party within 120 days of the receipt of the date of the unbillable usage.
- 6.8.8 The Initial Billing Party shall keep records of its billing activities relating to jointly-provided Intrastate and Interstate access services in sufficient detail to permit the Subsequent Billing Party to, by formal or informal review or audit, verify the accuracy and reasonableness of the jointly-provided access billing data provided by the Initial billing Party. Each Party agrees to cooperate in such formal or informal reviews or audits and further agrees to jointly review the findings of such reviews or audits in order to resolve any differences concerning the findings thereof.
- 6.8.9 Adelphia agrees not to deliver Switched Access Traffic to BellSouth for termination except over Adelphia ordered switched access trunks and facilities.

6.9 Transit Traffic Service. For purposes of this paragraph, “Transit Traffic” includes Adelphia Transit Traffic and Third-party Transit Traffic. “Adelphia Transit Traffic” is traffic originating on Adelphia’s network that is switched and/or transported by BellSouth and delivered to a third party’s network. “Third-party Transit Traffic” is traffic that originates on the network of a third party, is switched and/or transported by BellSouth, and is delivered to Adelphia for termination. BellSouth shall provide tandem switching and transport services for Adelphia Transit Traffic. Rates for Adelphia Transit Traffic shall be the call transport and termination charges set forth in Exhibit A to this Attachment for the functions BellSouth performs in switching and/or transporting Adelphia Transit Traffic. BellSouth shall not charge Adelphia for the transport and/or switching of Third-party Transit Traffic and Adelphia shall not charge BellSouth transport and termination for Third-party Transit Traffic. Transit Traffic that is Switched Access Traffic shall be subject to the applicable call transport and termination charges set forth in BellSouth’s or Adelphia’s FCC or Commission filed and effective Interstate or Intrastate Switched Access Tariffs and shall be billed in accordance with Section 6.8.2 of this Attachment. Wireless Type 1 traffic shall not be treated as Transit Traffic from a routing or billing perspective. Wireless Type 2A traffic shall not be treated as Transit Traffic from a routing or billing perspective until BellSouth and the wireless carrier have the capability to properly meet-point-bill in accordance with MECAB guidelines.

6.9.1 The delivery of traffic which transits the BellSouth network and is transported to another carrier’s network is excluded from any BellSouth billing guarantees and will be delivered at the rates stipulated in this Agreement to a terminating carrier. BellSouth agrees to deliver this traffic to Adelphia or the third-party carrier; provided, however, that Adelphia is solely responsible for negotiating and executing any appropriate contractual agreements with the third-party carrier for the receipt of this traffic through the BellSouth network. BellSouth will not be liable for any compensation to the terminating carrier or to Adelphia. Adelphia agrees to compensate BellSouth for any charges or costs for the delivery of Adelphia Transit Traffic to a connecting carrier on behalf of Adelphia. Additionally, the Parties agree that any billing to a third party or other telecommunications carrier under this section shall be pursuant to MECAB procedures.

7. Frame Relay Service

7.1 In addition to the Local Interconnection services set forth above, BellSouth will offer a network to network Interconnection arrangement between BellSouth’s and Adelphia’s frame relay switches as set forth below. The following provisions will apply only to Frame Relay Service and Exchange Access Frame Relay Service in those states in which Adelphia is certified and providing Frame Relay Service as a

Local Exchange Carrier and where traffic is being exchanged between Adelphia and BellSouth Frame Relay Switches in the same LATA.

- 7.2 The Parties agree to establish two-way Frame Relay facilities between their respective Frame Relay Switches to the mutually agreed upon Frame Relay Service point(s) of interconnection within the LATA. All point(s) of interconnection shall be within the same Frame Relay Network Serving Areas as defined in Section A40 of BellSouth's General Subscriber Service Tariff except as set forth in this Attachment.
- 7.3 Upon the request of either Party, such interconnection will be established where BellSouth and Adelphia have Frame Relay Switches in the same LATA. Where there are multiple Frame Relay switches in one central office, an interconnection with any one of the switches will be considered an interconnection with all of the switches at that central office for purposes of routing packet traffic.
- 7.4 The Parties agree to provision local and IntraLATA Frame Relay Service and Exchange Access Frame Relay Service (both intrastate and interstate) over Frame Relay interconnection facilities between the respective Frame Relay switches and the Frame Relay Service Point of Interconnection.
- 7.5 The Parties agree to assess each other reciprocal charges for the facilities that each provides to the other according to the Percent Local Circuit Use Factor (PLCU), determined as follows:
- 7.5.1 If the data packets originate and terminate in locations in the same LATA, the traffic is considered local. Frame Relay framed packet data is transported within Virtual Circuits (VC). For the purposes of this Agreement, if all the data packets transported within a VC remain within the LATA, then the traffic on that VC is local ("Local VC").
- 7.5.2 If the originating and terminating locations of the two way packet data traffic are not in the same LATA, the traffic on that VC is interLATA ("InterLATA VC").
- 7.5.3 The PLCU is determined by dividing the total number of Local VCs, by the total number of VCs on each Frame Relay facility. To facilitate implementation, Adelphia may determine its PLCU in aggregate, by dividing the total number of Local VCs in a given LATA by the total number VCs in that LATA. The Parties agree to renegotiate the method for determining PLCU, at BellSouth's request, and within 90 days, if BellSouth notifies Adelphia that it has found that this method does not adequately represent the PLCU.
- 7.5.4 If there are no VCs on a facility when it is billed, the PLCU will be zero.

- 7.5.5 BellSouth will provide the circuit between the Parties' respective Frame Relay Switches. The Parties will be compensated as follows: BellSouth will invoice, and Adelphia will pay, the total non-recurring and recurring charges for the circuit based upon the rates set forth in BellSouth's Interstate Access Tariff, FCC No. 1. Adelphia will then invoice, and BellSouth will pay, an amount calculated by multiplying the BellSouth billed charges for the circuit by one-half of Adelphia's PLCU.
- 7.6 The Parties agree to compensate each other for Frame Relay network-to-network interface (NNI) ports based upon the NNI rates set forth in BellSouth's Interstate Access Tariff, FCC No. 1. Compensation for each pair of NNI ports will be calculated as follows: BellSouth will invoice, and Adelphia will pay, the total non-recurring and recurring charges for the NNI port. Adelphia will then invoice, and BellSouth will pay, an amount calculated by multiplying the BellSouth billed non-recurring and recurring charges for the NNI port by Adelphia's PLCU.
- 7.7 Each Party agrees that there will be no charges to the other Party for its own subscriber's Permanent Virtual Circuit (PVC) rate elements for the local PVC segment from its Frame Relay switch to its own subscriber's premises. PVC rate elements include the Data Link Connection Identifier (DLCI) and Committed Information Rate (CIR).
- 7.8 For the PVC segment between the Adelphia and BellSouth Frame Relay switches, compensation for the PVC charges is based upon the rates in BellSouth's Interstate Access Tariff, FCC No. 1.
- 7.9 Compensation for PVC rate elements will be calculated as follows:
- 7.9.1 If Adelphia orders a VC connection between a BellSouth subscriber's PVC segment and a PVC segment from the BellSouth Frame Relay switch to the Adelphia Frame Relay switch, BellSouth will invoice, and Adelphia will pay, the total non-recurring and recurring PVC charges for the PVC segment between the BellSouth and Adelphia Frame Relay switches. If the VC is a Local VC, Adelphia will then invoice and BellSouth will pay, the total nonrecurring and recurring PVC charges billed for that segment. If the VC is not local, no compensation will be paid to Adelphia for the PVC segment.
- 7.9.2 If BellSouth orders a Local VC connection between a Adelphia subscriber's PVC segment and a PVC segment from the Adelphia Frame Relay switch to the BellSouth Frame Relay switch, BellSouth will invoice, and Adelphia will pay, the total non-recurring and recurring PVC and CIR charges for the PVC segment between the BellSouth and Adelphia Frame Relay switches. If the VC is a Local VC, Adelphia will then invoice and BellSouth will pay the total non-recurring and recurring PVC and CIR charges billed for that segment. If the VC is not local, no compensation will be paid to Adelphia for the PVC segment.

- 7.9.3 The Parties agree to compensate each other for requests to change a PVC segment or PVC service order record, according to the Feature Change charge as set forth in the BellSouth access tariff BellSouth Tariff FCC No, 1.
- 7.9.4 If Adelphia requests a change to a VC, BellSouth will invoice and Adelphia will pay a Feature Change charge for each affected PVC segment.
- 7.9.4.1 If BellSouth requests a change to a Local VC, Adelphia will invoice and BellSouth will pay a Feature Change charge for each affected PVC segment.
- 7.9.5 The Parties agree to limit the sum of the CIR for the VCs on a DS1 NNI port to not more than three times the port speed, or not more than six times the port speed on a DS3 NNI port.
- 7.9.6 Except as expressly provided herein, this Agreement does not address or alter in any way either Party's provision of Exchange Access Frame Relay Service or interLATA Frame Relay Service. All charges by each Party to the other for carriage of Exchange Access Frame Relay Service or interLATA Frame Relay Service are included in the BellSouth access tariff BellSouth Tariff FCC No, 1.
- 7.10 Adelphia will identify and report quarterly to BellSouth the PLCU of the Frame Relay facilities it uses, per Section 7.5.3 above.
- 7.11 Either Party may request a review or audit of the various service components, consistent with the provisions of Section 6.5 of this Attachment.
- 7.12 If during the term of this Agreement, BellSouth obtains authority to provide interLATA Frame Relay in any State, the Parties agree to renegotiate this arrangement for the exchange of Frame Relay Service Traffic within one hundred eighty (180) days of the date BellSouth receives interLATA authority. In the event the Parties fail to renegotiate this Section 8 within the one hundred eighty day period, they will submit this matter to the appropriate State commission(s) for resolution.

8. Operational Support Systems (OSS) Rates

- 8.1 BellSouth has developed and made available the following mechanized systems by which Adelphia may submit LSRs electronically.

| | |
|------|-----------------------------------|
| LENS | Local Exchange Navigation System |
| EDI | Electronic Data Interface |
| TAG | Telecommunications Access Gateway |

8.2 LSRs submitted by means of one of these interactive interfaces will incur an OSS electronic ordering charge as specified in the table below. An individual LSR will be identified for billing purposes by its Purchase Order Number (PON). LSRs submitted by means other than one of these interactive interfaces (mail, fax, courier, etc.) will incur a manual order charge as specified in the table below:

| OPERATIONAL SUPPORT SYSTEMS | AL, GA, LA, MS, NC, SC | FL, KY, TN |
|---|-----------------------------------|-------------------|
| OSS LSR charge, per LSR received from the CLEC by one of the OSS interactive interfaces | \$3.50 SOMECH | \$3.50 SOMECH |
| Incremental charge per LSR received from the CLEC by means other than one of the OSS interactive interfaces | See applicable rate element | \$19.99 SOMAN |

Note: In addition to the OSS charges, applicable discounted service order and related discounted charges apply per the tariff.

8.3 Denial/Restoral OSS Charge

In the event Adelphia provides a list of customers to be denied and restored, rather than an LSR, each location on the list will require a separate PON and, therefore will be billed as one LSR per location.

8.4 Cancellation OSS Charge

Adelphia will incur an OSS charge for an accepted LSR that is later canceled by Adelphia.

Note: Supplements or clarifications to a previously billed LSR will not incur another OSS charge.

8.5 Network Elements and Other Services Manual Additive

The Commissions in Alabama, Georgia, Louisiana, Mississippi and South Carolina have ordered incremental manual non-recurring charges (NRC) for Network Elements and Other Services ordered by means other than one of the interactive interfaces. These ordered Network Elements and Other Services manual additive NRCs will apply in these states, rather than the charge per LSR.

Basic Architecture

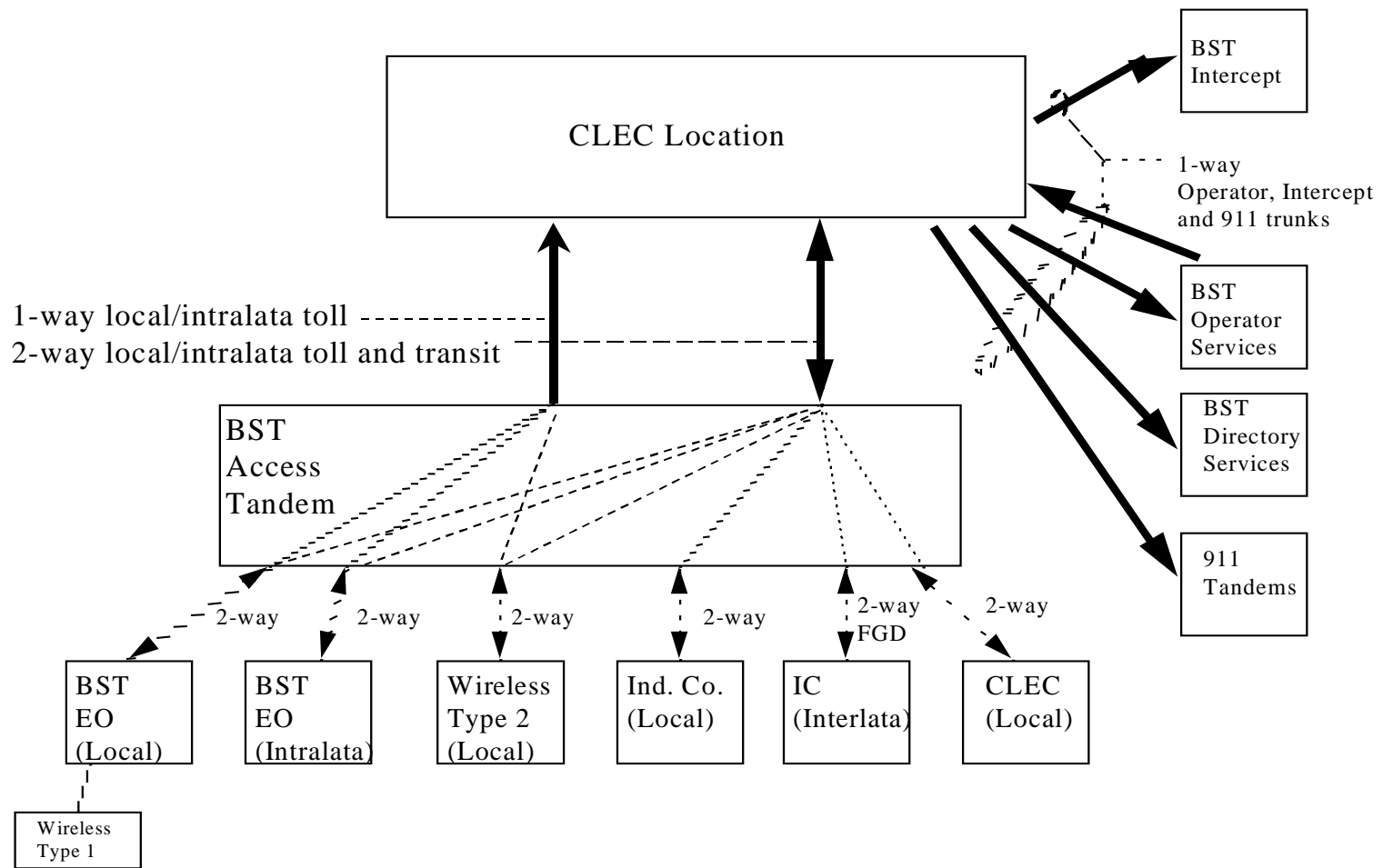

Exhibit B

One-Way Trunking Architecture

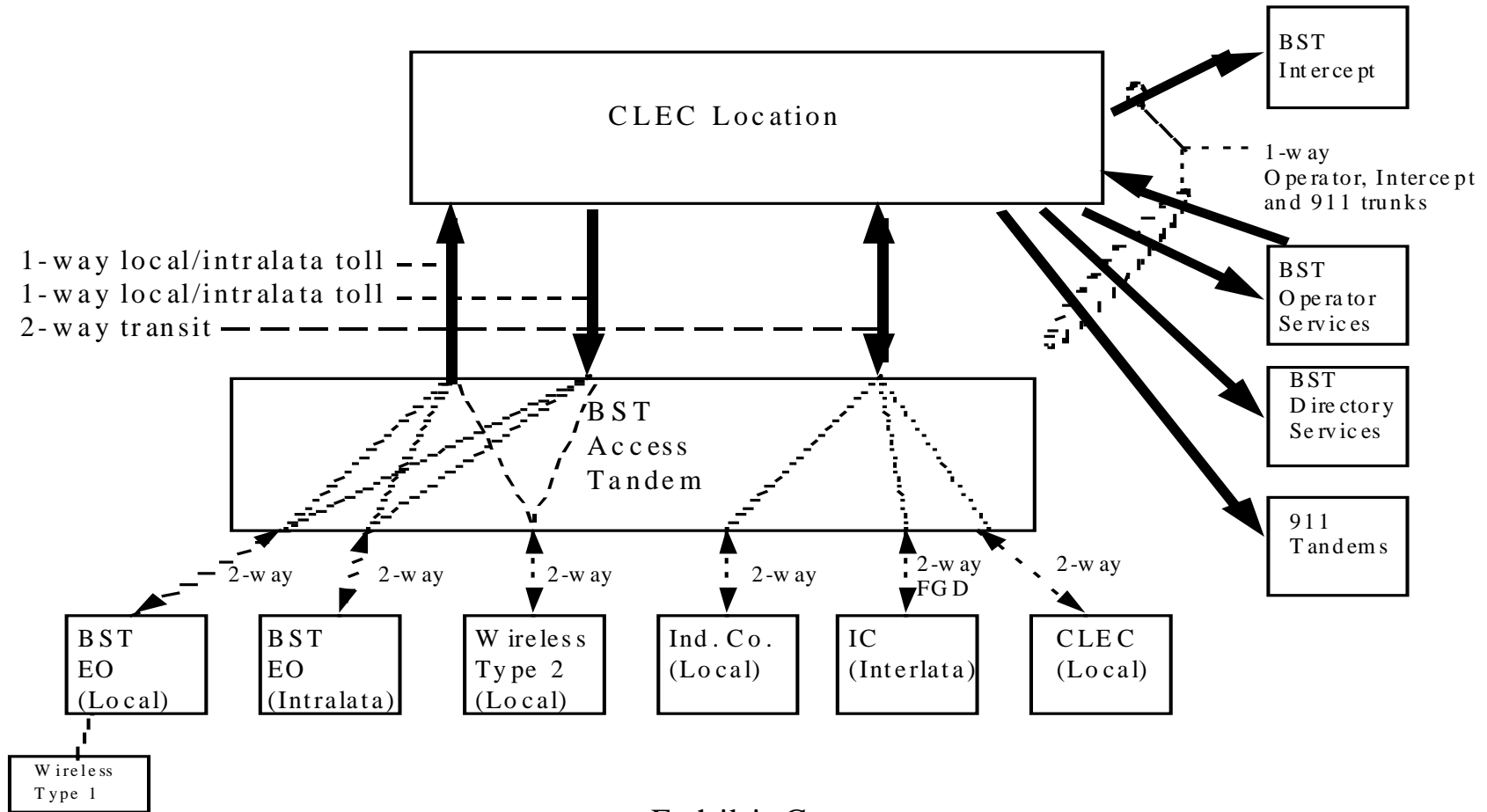

Exhibit C

Two-Way Trunking Architecture

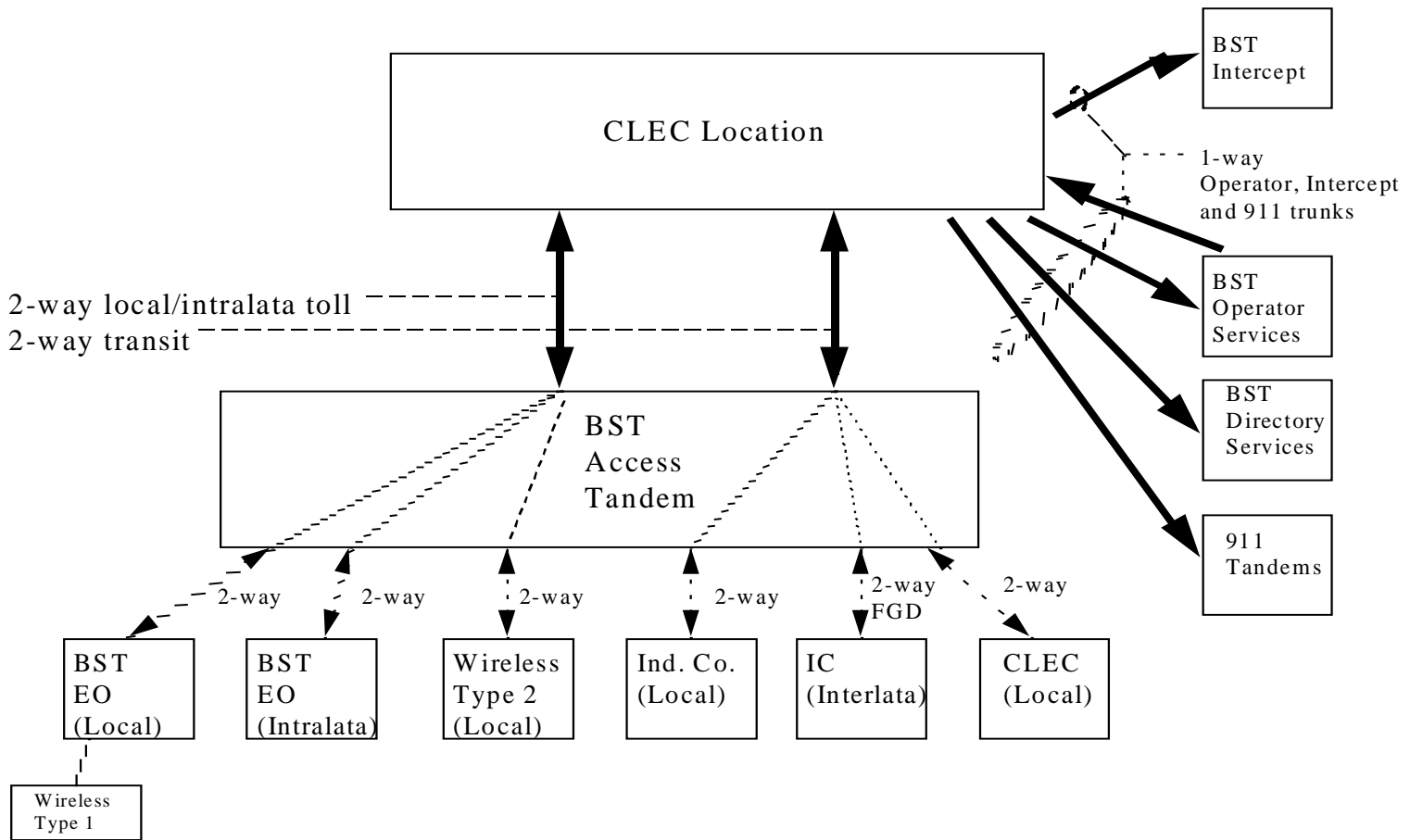

Exhibit D

SuperGroup Architecture

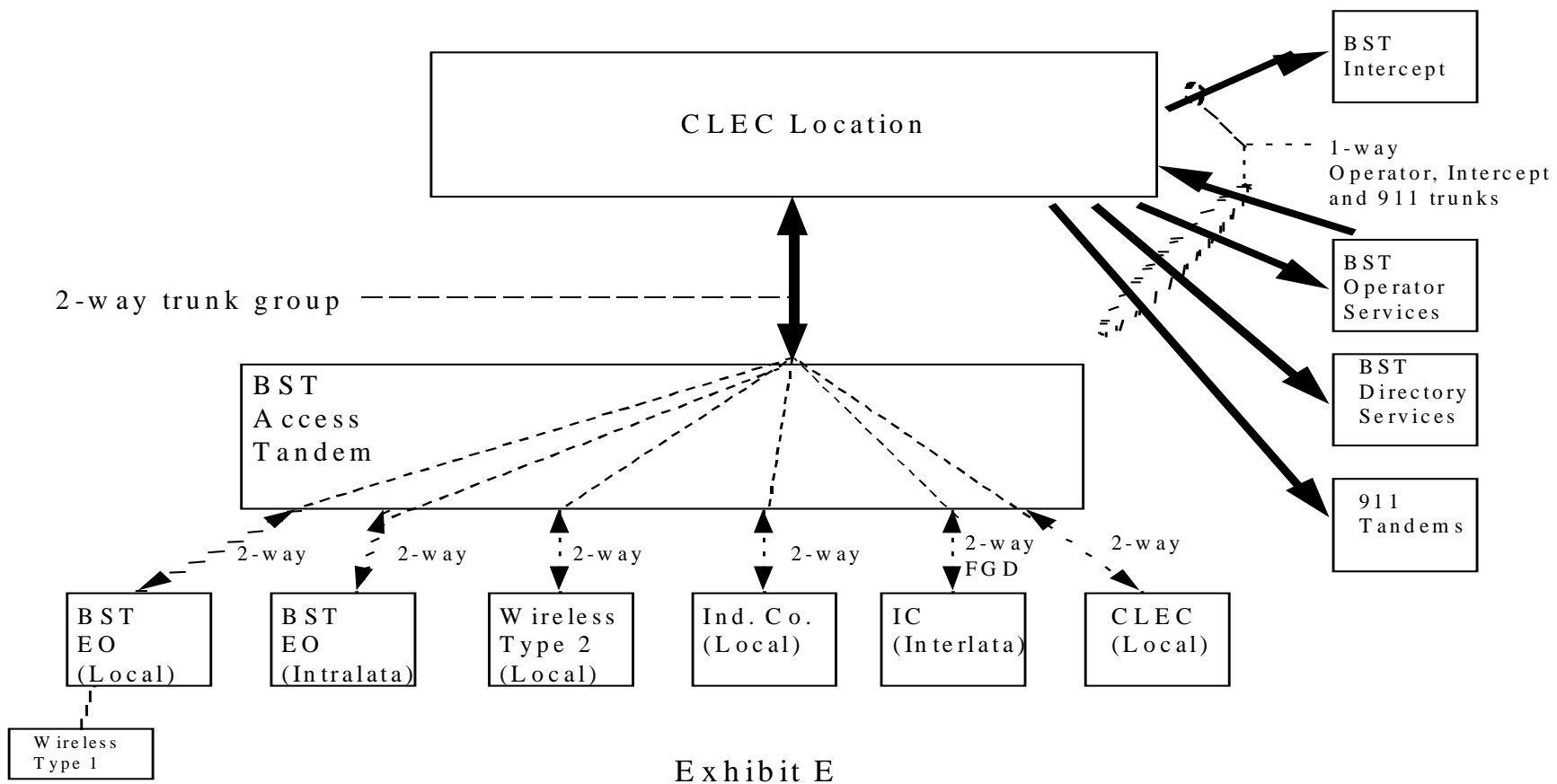

Exhibit E

BELLSOUTH/ADELPHIA RATES
LOCAL INTERCONNECTION

| DESCRIPTION | USOC | KY |
|--|-------|------------|
| LOCAL INTERCONNECTION (CALL TRANSPORT AND TERMINATION) | | |
| End Office Switching, per mou | N/A | \$0.002562 |
| Direct Local Interconnection, per mou (same as End Office Switching in FL & LA) | | NA |
| Tandem Switching, per mou | N/A | \$0.001096 |
| Tandem Local Interconnection, per mou (includes end office switching element) | N/A | NA |
| Multiple Tandem Switching, per mou (applies to initial tandem only), effective 10/99 | N/A | NA |
| Local Intermediary, per mou (applies to transit traffic only) | N/A | NA |
| Tandem Intermediary Charge, per mou* | N/A | \$0.001096 |
| *(This charge is applicable only to transit traffic and is applied in addition to applicable switching and/or interconnection charges.) | | |
| TRUNK CHARGE | | |
| Interim charges, both non-recurring and recurring, associated with interconnecting trunk groups between BellSouth and Adelphia shall be as set forth in this Exhibit. At such time as BellSouth develops a final cost based rate for such interconnecting trunk groups, the Parties shall amend this agreement to include such final cost based rates and shall true up such charges in accordance with this Attachment. | | |
| Installation Trunk Side Service - per DSO | | |
| NRC - 1st | TPP++ | \$334.09 |
| NRC - Add'l | TPP++ | \$57.12 |
| INTEROFFICE TRANSPORT | | |
| Common (Shared) Transport | | |
| Common (Shared) Transport per mile per mou | N/A | \$0.000049 |
| Common (Shared) Transport Facilities Termination per mou | N/A | \$0.000426 |
| Interoffice Channel Transport - Dedicated - VG | | |
| Interoffice Transport - Dedicated - 2-wire VG | | |
| 2-Wire VG - per mile per month | 1L5XF | NA |
| 2-Wire VG - Facility Termination per month | 1L5XF | NA |
| NRC - 2-wire VG - Facility Termination -1st | 1L5XF | NA |
| NRC - 2-wire VG - Facility Termination - Add'l | 1L5XF | NA |
| NRC - 2-wire VG -Facility Termination - Disconnect Charge -1st | 1L5XF | NA |
| NRC - 2-wire VG - Facility Termination - Disconnect Charge -Add'l | 1L5XF | NA |
| NRC - Manual Svc Order, per LSR | SOMAN | NA |
| NRC - Manual Svc Order, per LSR disconnect | SOMAN | NA |
| NRC - Electronic Svc Order, per LSR | SOMEK | NA |
| NRC - Electronic Svc Order, per LSR disconnect | SOMEK | NA |
| NRC - 2-wire VG - Incremental Charge--Manual Svc Order - 1st | SOMAN | NA |
| NRC - 2-wire VG - Incremental Charge--Manual Svc Order - Add'l | SOMAN | NA |
| NRC - 2-wire VG - Incremental Charge--Manual Svc Order-Disconnect--1st | SOMAN | NA |
| NRC - 2-wire VG - Incremental Charge--Manual Svc Order-Disconnect--Add'l | SOMAN | NA |
| Interoffice Transport - Dedicated - 2 Wire VG - Kentucky & Mississippi | | |
| 2-Wire VG - per mile per month | 1L5NF | \$0.03 |
| 2-Wire VG - Facility Termination per month | 1L5NF | \$27.66 |
| NRC - 2-wire VG - Facility Termination -1st | 1L5NF | \$142.31 |
| NRC - 2-wire VG - Facility Termination - Add'l | 1L5NF | \$56.21 |
| NRC - 2-wire VG -Facility Termination - Disconnect Charge -1st | 1L5NF | NA |
| NRC - 2-wire VG - Facility Termination - Disconnect Charge -Add'l | 1L5NF | NA |
| NRC - Manual Svc Order, per LSR | SOMAN | \$19.99 |

Version 2000:7/24/00

BELLSOUTH/ADELPHIA RATES
LOCAL INTERCONNECTION

| DESCRIPTION | USOC | KY |
|--|--------|----------|
| NRC - Manual Svc Order, per LSR disconnect | SOMAN | NA |
| NRC - Electronic Svc Order, per LSR | SOMECE | \$3.50 |
| NRC - Electronic Svc Order, per LSR disconnect | SOMECE | NA |
| NRC - 2-wire VG - Incremental Charge--Manual Svc Order - 1st | SOMAN | NA |
| NRC - 2-wire VG - Incremental Charge--Manual Svc Order - Add'l | SOMAN | NA |
| NRC - 2-wire VG - Incremental Charge--Manual Svc Order-Disconnect--1st | SOMAN | NA |
| NRC - 2-wire VG - Incremental Charge--Manual Svc Order-Disconnect--Add'l | SOMAN | NA |
| Interoffice Transport - Dedicated - DS0 - 56/64 KBPS | | |
| DS0 - per mile per month | 1L5XK | NA |
| DS0 - Facility Termination per month | 1L5XK | NA |
| NRC - DS0 - Facility Termination - 1st | 1L5XK | NA |
| NRC - DS0 - Facility Termination - Add'l | 1L5XK | NA |
| NRC - DS0 -Facility Termination - Disconnect Charge - 1st | 1L5XK | NA |
| NRC - DS0 - Facility Termination - Disconnect Charge - Add'l | 1L5XK | NA |
| NRC - Manual Svc Order, per LSR | SOMAN | NA |
| NRC - Manual Svc Order, per LSR disconnect | SOMAN | NA |
| NRC - Electronic Svc Order, per LSR | SOMECE | NA |
| NRC - Electronic Svc Order, per LSR disconnect | SOMECE | NA |
| NRC - DS0 -Incremental Charge--Manual Svc Order - 1st | SOMAN | NA |
| NRC -DS0 - Incremental Charge--Manual Svc Order - Add'l | SOMAN | NA |
| NRC - DS0 -Incremental Charge--Manual Svc Order-Disconnect--1st | SOMAN | NA |
| NRC - DS0 -Incremental Charge--Manual Svc Order-Disconnect--Add'l | SOMAN | NA |
| Interoffice Transport - Dedicated - DS0 - 56/64 KBPS - Kentucky & Mississippi | | |
| DS0 - per mile per month | 1L5NK | \$0.45 |
| DS0 - Facility Termination per month | 1L5NK | \$55.05 |
| NRC - DS0 - Facility Termination - 1st | 1L5NK | \$298.18 |
| NRC - DS0 - Facility Termination - Add'l | 1L5NK | \$231.23 |
| NRC - DS0 -Facility Termination - Disconnect Charge - 1st | 1L5NK | NA |
| NRC - DS0 - Facility Termination - Disconnect Charge - Add'l | 1L5NK | NA |
| NRC - Manual Svc Order, per LSR | SOMAN | \$19.99 |
| NRC - Manual Svc Order, per LSR disconnect | SOMAN | NA |
| NRC - Electronic Svc Order, per LSR | SOMECE | \$3.50 |
| NRC - Electronic Svc Order, per LSR disconnect | SOMECE | NA |
| NRC - DS0 -Incremental Charge--Manual Svc Order - 1st | SOMAN | NA |
| NRC -DS0 - Incremental Charge--Manual Svc Order - Add'l | SOMAN | NA |
| NRC - DS0 -Incremental Charge--Manual Svc Order-Disconnect--1st | SOMAN | NA |
| NRC - DS0 -Incremental Charge--Manual Svc Order-Disconnect--Add'l | SOMAN | NA |
| Interoffice Transport - Dedicated - DS1 | | |
| DS1 - per mile per month | 1L5XL | NA |
| DS1 -Facility Termination per month | 1L5XL | NA |
| NRC - DS1-Facility Termination - 1st | 1L5XL | NA |
| NRC - DS1 - Facility Termination - Add'l | 1L5XL | NA |
| NRC - DS1 - Facility Termination - Disconnect Charge - 1st | 1L5XL | NA |
| NRC - DS1 - Facility Termination -Disconnect Charge - Add'l | 1L5XL | NA |
| NRC - Manual Svc Order, per LSR | SOMAN | NA |

BELLSOUTH/ADELPHIA RATES
 LOCAL INTERCONNECTION

| DESCRIPTION | USOC | KY |
|---|--------|------------|
| NRC - Manual Svc Order, per LSR disconnect | SOMAN | NA |
| NRC - Electronic Svc Order, per LSR | SOMECE | NA |
| NRC - Electronic Svc Order, per LSR disconnect | SOMECE | NA |
| NRC - DS1 - Incremental Charge--Manual Svc Order - 1st | SOMAN | NA |
| NRC -DS1 - Incremental Charge--Manual Svc Order - Add'l | SOMAN | NA |
| NRC - DS1 - Incremental Charge--Manual Svc Order-Disconnect--1st | SOMAN | NA |
| NRC - DS1 - Incremental Charge--Manual Svc Order-Disconnect--Add'l | SOMAN | NA |
| Interoffice Transport - Dedicated - DS1 - Kentucky & Mississippi | | |
| DS1 - per mile per month | 1L5NL | \$0.45 |
| DS1 -Facility Termination per month | 1L5NL | \$55.05 |
| NRC - DS1-Facility Termination - 1st | 1L5NL | \$298.18 |
| NRC - DS1 - Facility Termination - Add'l | 1L5NL | \$231.23 |
| NRC - DS1 - Facility Termination - Disconnect Charge - 1st | 1L5NL | NA |
| NRC - DS1 - Facility Termination -Disconnect Charge - Add'l | 1L5NL | NA |
| NRC - Manual Svc Order, per LSR | SOMAN | \$19.99 |
| NRC - Manual Svc Order, per LSR disconnect | SOMAN | NA |
| NRC - Electronic Svc Order, per LSR | SOMECE | \$3.50 |
| NRC - Electronic Svc Order, per LSR disconnect | SOMECE | NA |
| NRC - DS1 - Incremental Charge--Manual Svc Order - 1st | SOMAN | NA |
| NRC -DS1 - Incremental Charge--Manual Svc Order - Add'l | SOMAN | NA |
| NRC - DS1 - Incremental Charge--Manual Svc Order-Disconnect--1st | SOMAN | NA |
| NRC - DS1 - Incremental Charge--Manual Svc Order-Disconnect--Add'l | SOMAN | NA |
| Interoffice Transport - Dedicated - DS3 | | |
| DS3 - per mile per month | 1L5XM | NA |
| DS3 -Facility Termination per month | 1L5XM | NA |
| NRC - DS3 - Facility Termination -1st | 1L5XM | NA |
| NRC - DS3 - Facility Termination - Add'l | 1L5XM | NA |
| NRC - DS3 - Facility Termination - Disconnect Charge - 1st | 1L5XM | NA |
| NRC - DS3 - Facility Termination - Disconnect Charge - Add'l | 1L5XM | NA |
| NRC - Manual Svc Order, per LSR | SOMAN | NA |
| NRC - Manual Svc Order, per LSR disconnect | SOMAN | NA |
| NRC - Electronic Svc Order, per LSR | SOMECE | NA |
| NRC - Electronic Svc Order, per LSR disconnect | SOMECE | NA |
| NRC - DS3 - Incremental Charge--Manual Svc Order - 1st | SOMAN | NA |
| NRC - DS3 - Incremental Charge--Manual Svc Order - Add'l | SOMAN | NA |
| NRC - DS3 - Incremental Charge--Manual Svc Order-Disconnect--1st | SOMAN | NA |
| NRC - DS3 - Incremental Charge--Manual Svc Order-Disconnect--Add'l | SOMAN | NA |
| Interoffice Transport - Dedicated - DS3 - Kentucky & Mississippi | | |
| DS3 - per mile per month | 1L5NM | \$12.06 |
| DS3 -Facility Termination per month | 1L5NM | \$1,112.02 |
| NRC - DS3 - Facility Termination -1st | 1L5NM | \$858.75 |
| NRC - DS3 - Facility Termination - Add'l | 1L5NM | \$524.95 |
| NRC - DS3 - Facility Termination - Disconnect Charge - 1st | 1L5NM | NA |
| NRC - DS3 - Facility Termination - Disconnect Charge - Add'l | 1L5NM | NA |
| NRC - Manual Svc Order, per LSR | SOMAN | \$19.99 |
| NRC - Manual Svc Order, per LSR disconnect | SOMAN | NA |

BELLSOUTH/ADELPHIA RATES
 LOCAL INTERCONNECTION

| DESCRIPTION | USOC | KY |
|---|-------|----------|
| NRC - Electronic Svc Order, per LSR | SOMEK | \$3.50 |
| NRC - Electronic Svc Order, per LSR disconnect | SOMEK | NA |
| NRC - DS3 - Incremental Charge--Manual Svc Order - 1st | SOMAN | NA |
| NRC - DS3 - Incremental Charge--Manual Svc Order - Add'l | SOMAN | NA |
| NRC - DS3 - Incremental Charge--Manual Svc Order-Disconnect--1st | SOMAN | NA |
| NRC - DS3 - Incremental Charge--Manual Svc Order-Disconnect--Add'l | SOMAN | NA |
| Local Channel - Dedicated | | |
| Local Channel - Dedicated - 2-Wire VG | | |
| Monthly Recurring per month | TEFV2 | \$22.26 |
| Zone 1 | TBD | NA |
| Zone 2 | TBD | NA |
| Zone 3 | TBD | NA |
| Zone 4 | TBD | NA |
| NRC - STS-1 - Facility Termination - 1st | TEFV2 | \$585.15 |
| NRC - STS-1 - Facility Termination - Add'l | TEFV2 | \$98.53 |
| NRC - STS-1 - Facility Termination - Disconnect - 1st | TEFV2 | \$11.99 |
| NRC - STS-1 - Facility Termination - Disconnect - Add'l | TEFV2 | NA |
| NRC - Manual Svc Order, per LSR | SOMAN | \$19.99 |
| NRC - Manual Svc Order, per LSR disconnect | SOMAN | NA |
| NRC - Electronic Svc Order, per LSR | SOMEK | \$3.50 |
| NRC - Electronic Svc Order, per LSR disconnect | SOMEK | NA |
| NRC - STS-1 - Incremental Charge--Manual Svc Order - 1st | SOMAN | NA |
| NRC - STS-1 - Incremental Charge--Manual Svc Order - Add'l | SOMAN | NA |
| NRC - STS-1 - Incremental Cost - Manual Svc. Order vs. Elect-Disconnect-1st | SOMAN | NA |
| Local Channel - Dedicated - 4-Wire VG | | |
| Monthly Recurring per month | TEFV4 | \$23.38 |
| Zone 1 | TBD | NA |
| Zone 2 | TBD | NA |
| Zone 3 | TBD | NA |
| Zone 4 | TBD | NA |
| NRC - 4-Wire VG - 1st | TEFV4 | \$585.15 |
| NRC - 4-Wire VG - Add'l | TEFV4 | \$98.53 |
| NRC - 4-Wire VG - Disconnect Chg - 1st | TEFV4 | NA |
| NRC - 4-Wire VG - Disconnect Chg - Add'l | TEFV4 | NA |
| NRC - Manual Svc Order, per LSR | SOMAN | \$19.99 |
| NRC - Manual Svc Order, per LSR disconnect | SOMAN | NA |
| NRC - Electronic Svc Order, per LSR | SOMEK | \$3.50 |
| NRC - Electronic Svc Order, per LSR disconnect | SOMEK | NA |
| NRC - 4-Wire VG - Incremental Charge--Manual Svc Order - 1st | SOMAN | NA |
| NRC - 4-Wire VG - Incremental Charge--Manual Svc Order - Add'l | SOMAN | NA |
| Local Channel - Dedicated - DS1 | | |
| DS1 Monthly Recurring per month | TEFHG | \$43.80 |
| DS1 per mile per month | 1L5NC | \$0.00 |
| Zone 1 | TBD | NA |
| Zone 2 | TBD | NA |
| Zone 3 | TBD | NA |

BELLSOUTH/ADELPHIA RATES
 LOCAL INTERCONNECTION

| DESCRIPTION | USOC | KY |
|---|-------|------------|
| Zone 4 | TBD | NA |
| NRC - DS1 - 1st | TEFHG | \$538.95 |
| NRC - DS1 - Add'l | TEFHG | \$464.94 |
| NRC - DS1 - Disconnect Chg - 1st | TEFHG | NA |
| NRC - DS1 - Disconnect Chg - Add'l | TEFHG | NA |
| NRC - Manual Svc Order, per LSR | SOMAN | \$19.99 |
| NRC - Manual Svc Order, per LSR disconnect | SOMAN | NA |
| NRC - Electronic Svc Order, per LSR | SOMEK | \$3.50 |
| NRC - Electronic Svc Order, per LSR disconnect | SOMEK | NA |
| NRC - DS1 - Incremental Charge--Manual Svc Order - 1st | SOMAN | NA |
| NRC - DS1 - Incremental Charge--Manual Svc Order - Add'l | SOMAN | NA |
| Local Channel - Dedicated - DS3 | | |
| DS3 - per mile per month | 1L5NC | \$34.00 |
| DS3 - Facility Termination per month | TEFHJ | \$635.09 |
| NRC - DS3 - Facility Termination - 1st | TEFHJ | \$1,091.00 |
| NRC - DS3 - Facility Termination - Add'l | TEFHJ | \$661.23 |
| NRC - DS3 - Facility Termination - Disconnect - 1st | TEFHJ | NA |
| NRC - DS3 - Facility Termination - Disconnect - Add'l | TEFHJ | NA |
| NRC - Manual Svc Order, per LSR | SOMAN | \$19.99 |
| NRC - Manual Svc Order, per LSR disconnect | SOMAN | NA |
| NRC - Electronic Svc Order, per LSR | SOMEK | \$3.50 |
| NRC - Electronic Svc Order, per LSR disconnect | SOMEK | NA |
| NRC - DS3 -Incremental Charge--Manual Svc Order - 1st | SOMAN | NA |
| NRC - DS3 - Incremental Charge--Manual Svc Order - Add'l | SOMAN | NA |
| NRC - DS3 - Incremental Charge--Manual Svc Order-Disconnect -1st | SOMAN | NA |
| NRC - DS3 - Incremental Charge--Manual Svc Order-Disconnect-Add'l | SOMAN | NA |
| CHANNELIZATION | | |
| DS3 Channelization (DS3 to DS1) | | |
| per Channelized System (28 DS1) per month | SATCS | NA |
| NRC - 1st | SATCS | NA |
| NRC - Add'l | SATCS | NA |
| NRC -1st - Disconnect | SATCS | NA |
| NRC -Add'l - Disconnect | SATCS | NA |
| per Interface per month (COC) | SATCO | NA |
| NRC - 1st | SATCO | NA |
| NRC - Add'l | SATCO | NA |
| NRC - Manual Svc Order, per LSR | SOMEK | NA |
| NRC - Manual Svc Order, per LSR disconnect | SOMAN | NA |
| NRC - Electronic Svc Order, per LSR | SOMAN | NA |
| NRC - Electronic Svc Order, per LSR disconnect | SOMAN | NA |
| Channel System - Incremental Cost - Manual Svc. Order vs. Electronic -1st | SOMAN | NA |
| Channel System - Incremental Cost - Manual Svc. Order vs. Electronic -Add'l | SOMAN | NA |
| DS3 Channelization (DS3 to DS1) - Kentucky & Mississippi | | |
| per Channelized System (28 DS1) per month | SATNS | \$303.33 |
| NRC - 1st | SATNS | NA |

Version 2Q00: 7/24/00

BELLSOUTH/ADELPHIA RATES
LOCAL INTERCONNECTION

| DESCRIPTION | USOC | KY |
|---|--------|----------|
| NRC - Add'l | SATNS | NA |
| NRC -1st - Disconnect | SATNS | \$8.52 |
| NRC -Add'l - Disconnect | SATNS | \$15.86 |
| per Interface per month (COCI) | SATCO | \$11.36 |
| NRC - 1st | SATCO | \$19.99 |
| NRC - Add'l | SATCO | NA |
| NRC - Manual Svc Order, per LSR | SOMAN | \$3.50 |
| NRC - Manual Svc Order, per LSR disconnect | SOMAN | NA |
| NRC - Electronic Svc Order, per LSR | SOMEK | NA |
| NRC - Electronic Svc Order, per LSR disconnect | SOMEK | NA |
| Channel System - Incremental Cost - Manual Svc. Order vs. Electronic -1st | SOMAN | NA |
| Channel System - Incremental Cost - Manual Svc. Order vs. Electronic -Add'l | SOMAN | NA |
| DS1 Channelization (DS1 to DS0) | | |
| per Channelized System (24 DS0) per month | SATC1 | NA |
| NRC - 1st | SATC1 | NA |
| NRC - Add'l | SATC1 | NA |
| NRC -1sr - Disconnect | SATC1 | NA |
| NRC -Add'l - Disconnect | SATC1 | NA |
| - Interface (COCI) | | |
| per OCU-DP(data) card per month (2.4-64kbs) | SATSA | NA |
| NRC - 1st | SATSA | NA |
| NRC - Add'l | SATSA | NA |
| per BRITE card per month | SATSA | NA |
| NRC - 1st | SATSA | NA |
| NRC - Add'l | SATSA | NA |
| per VG card per month (DS0) | SATSA | NA |
| NRC - 1st | SATSA | NA |
| NRC - Add'l | SATSA | NA |
| NRC - Manual Svc Order, per LSR | SOMAN | NA |
| NRC - Manual Svc Order, per LSR disconnect | SOMAN | NA |
| NRC - Electronic Svc Order, per LSR | SOMEK | NA |
| NRC - Electronic Svc Order, per LSR disconnect | SOMEK | NA |
| Channel System - Incremental Cost - Manual Svc. Order vs. Electronic -1st | SOMAN | NA |
| Channel System - Incremental Cost - Manual Svc. Order vs. Electronic -Add'l | SOMAN | NA |
| Incremental Cost-Manual Svc. Order vs. Elect -Disconnect - 1st | SOMAN | NA |
| Incremental Cost-Manual Svc. Order vs. Elect -Disconnect - Add'l | SOMAN | NA |
| DS1 Channelization (DS1 to DS0) - Kentucky & Mississippi | | |
| per Channelized System (24 DS0) per month | SASTN1 | \$200.01 |
| NRC - 1st | SASTN1 | \$302.82 |
| NRC - Add'l | SASTN1 | \$184.20 |
| NRC -1sr - Disconnect | SASTN1 | NA |
| NRC -Add'l - Disconnect | SASTN1 | NA |
| - Interface (COCI) | | |
| per OCU-DP(data) card per month (2.4-64kbs) | SATSA | \$2.94 |
| NRC - 1st | SATSA | \$15.86 |
| NRC - Add'l | SATSA | \$11.36 |
| per BRITE card per month | SATSA | \$4.04 |
| NRC - 1st | SATSA | \$15.86 |
| NRC - Add'l | SATSA | \$11.36 |

Version 2Q00: 7/24/00

BELLSOUTH/ADELPHIA RATES
 LOCAL INTERCONNECTION

| DESCRIPTION | USOC | KY |
|---|-------|----------|
| per VG card per month (DS0) | SATSA | \$1.40 |
| NRC - 1st | SATSA | \$15.86 |
| NRC - Add'l | SATSA | \$11.36 |
| NRC - Manual Svc Order, per LSR | SOMAN | \$19.99 |
| NRC - Manual Svc Order, per LSR disconnect | SOMAN | NA |
| NRC - Electronic Svc Order, per LSR | SOMEK | \$3.50 |
| NRC - Electronic Svc Order, per LSR disconnect | SOMEK | NA |
| Channel System - Incremental Cost - Manual Svc. Order vs. Electronic -1st | SOMAN | NA |
| Channel System - Incremental Cost - Manual Svc. Order vs. Electronic -Add'l | SOMAN | NA |
| Incremental Cost-Manual Svc. Order vs. Elect -Disconnect - 1st | SOMAN | NA |
| Incremental Cost-Manual Svc. Order vs. Elect -Disconnect - Add'l | SOMAN | NA |
| Local Interconnection Mid-Span Meet | | |
| Local Channel - Dedicated - DS1 | | |
| DS1 Monthly Recurring per month | TEFHG | \$21.90 |
| NRC - DS1 - 1st | TEFHG | \$269.48 |
| NRC - DS1 - Add'l | TEFHG | \$232.47 |
| NRC - DS1 - Disconnect Chg - 1st | TEFHG | NA |
| NRC - DS1 - Disconnect Chg - Add'l | TEFHG | NA |
| NRC - DS1 - Incremental Charge-Manual Svc Order - 1st | SOMAC | \$87.71 |
| NRC - DS1 - Incremental Charge-Manual Svc Order - Add'l | SOMAC | NA |
| NRC - DS1 - Incremental Charge-Manual Svc Order-Disconnect | SOMAC | NA |
| NOTES: | | |
| If no rate is identified in the contract, the rate for the specific service or function will be as set forth in applicable BellSouth tari | | |

Attachment 4
Physical Collocation

BELLSOUTH PHYSICAL COLLOCATION

1. SCOPE OF ATTACHMENT

1.1 Scope of Attachment. The rates, terms, and conditions contained within this Attachment shall only apply when Adelphia is occupying the collocation space as a sole occupant or as a Host pursuant to Section 4.

Negotiated rates, terms and conditions set forth in this Attachment pertain to collocation and the provisioning of collocation space.

1.2 Right to occupy. Subject to Section 4 of this Attachment, BellSouth hereby grants to Adelphia a right to occupy that certain area designated by BellSouth within a BellSouth central office premises, of a size which is specified by Adelphia and agreed to by BellSouth (hereinafter "Collocation Space"). The size specified by Adelphia may contemplate a request for space sufficient to accommodate Adelphia's growth within a two year period unless otherwise agreed to by the Parties.

1.2.1 Space Reclamation. In the event of space exhaust within a central office premises, Adelphia may be required to release space to BellSouth to be allocated to other physical collocation applicants when a minimum of fifty percent of the total amount of space in Adelphia's collocation arrangement is not being utilized within the first year of operation, or 100% of the total amount of space by the end of the second year of operation.

1.3 Use of Space. Adelphia shall use the Collocation Space for the purposes of installing, maintaining and operating Adelphia's equipment (to include testing and monitoring equipment) that is necessary to interconnect with BellSouth services and facilities, including access to unbundled network elements, for the provision of telecommunications services. Pursuant to Section 5 following, Adelphia may at its option, place Adelphia-owned or leased fiber entrance facilities to the Collocation Space. In addition to, and not in lieu of, interconnection to BellSouth services and facilities, Adelphia may connect to other interconnectors within the designated BellSouth Central Office (including to its other virtual or physical collocated arrangements) through co-carrier cross connect facilities designated by Adelphia pursuant to section 5.6 following. The Collocation Space may be used for no other purposes except as specifically described herein or authorized in writing by BellSouth.

1.4 Rates and charges. Adelphia agrees to pay the rates and charges identified at Exhibit A attached hereto. Rates marked with an asterisk are interim and subject to true-up pursuant to Section 7.7.

2. SPACE NOTIFICATION

2.1 Availability of Space. Upon submission of an application pursuant to Section 6, BellSouth will provide Adelphia physical collocation, pursuant to the terms of this Attachment, at any BellSouth central office premises, unless BellSouth is prepared to demonstrate to the Public Service Commission that there is no space available due to space limitations or no space available due to technical infeasibility. BellSouth will respond to an application within ten (10) business days as to whether space is available or not available within a BellSouth central office

premises. BellSouth shall, upon request from Adelphia, remove obsolete unused equipment from its premises prior to BellSouth's scheduled removal of such equipment, to increase the amount of space available for collocation. Adelphia shall pay a pro rata share of equipment removal costs that is proportionate to its share of the space that is made available by the removal of equipment.

2.2 Reporting. Upon request from Adelphia, BellSouth will provide a written report specifying the amount of collocation space available at the central office premises requested, the number of collocators present at the central office premises, any modifications in the use of the space since the last report or the central office premises requested and the measures BellSouth is taking to make additional space available for collocation arrangements.

2.2.1 The request from Adelphia must be written and must include the central office premises and Common Language Location Identification (CLLI) code of the central office premises. Such information regarding central office premises and CLLI code is located in the National Exchange Carriers Association (NECA) Tariff FCC No. 4.

2.2.2 BellSouth will respond to a request for a particular Central Office location within ten (10) business days of receipt of such request. BellSouth will make best efforts to respond in ten (10) business days to such a request when the request includes up to and including five (5) Central Office locations within the same state. The response time for requests of more than five (5) shall be negotiated between the Parties. If BellSouth cannot meet the ten business day response time, for the second through fifth requests, BellSouth shall notify Adelphia and inform Adelphia of the time frame under which it can respond, which shall be as soon as reasonably possible.

2.3 Denial of Application. After notifying Adelphia that BellSouth has no available space in the requested Central Office ("Denial of Application"), BellSouth will allow Adelphia, upon request, to tour the entire Central Office within ten (10) business days of such Denial of Application. In order to schedule said tour within ten (10) business days, the request for a tour of the Central Office must be received by BellSouth within five (5) business days of the Denial of Application.

2.4 Filing of Petition for Waiver. Upon Denial of Application BellSouth will timely file a petition with the Commission pursuant to 47 U.S.C. § 251(c)(6).

2.5 Waiting List. On a first come first served basis, BellSouth will maintain a waiting list of requesting carriers who have either received a Denial of Application or, where it is publicly known that the central office premises is out of space, have submitted a Letter of Intent to collocate. BellSouth will notify the telecommunications carriers on the waiting list when space becomes available according to how much space becomes available and the position of telecommunications carrier on said waiting list. Upon request BellSouth will advise Adelphia as to its position on the list.

2.6 Public Notification. BellSouth will maintain on its Interconnection Services website a notification document that will indicate all central office premises that are without available space. BellSouth shall update such document within ten (10) business days of the Denial of Application date. BellSouth will also post a document on its Interconnection Services website that contains a general notice where space has become available in a Central Office previously on the space exhaust list. BellSouth shall allocate said available space pursuant to the waiting list referenced in Section 2.5.

2.7 State Agency Procedures. Notwithstanding the foregoing, should any regulatory agency with jurisdiction over the procedures set forth in this section impose a procedure different than procedures set forth in this section, such procedure shall supersede the requirements set forth herein.

3. COLLOCATION OPTIONS

3.1 Cageless. Except where local building code does not allow cageless collocation, BellSouth shall provide Adelphia collocation for Adelphia's equipment and facilities without requiring the construction of a cage or similar structure. BellSouth shall allow Adelphia to have direct access to its equipment and facilities but may require Adelphia to use a central entrance to the BellSouth Central Office. BellSouth shall make cageless collocation available in single bay increments pursuant to Section 7. Except where Adelphia's equipment requires special technical considerations (e.g., special cable racking, isolated ground plane), BellSouth shall assign cageless Collocation Space in conventional equipment rack lineups where feasible. For equipment requiring special technical considerations, Adelphia must provide the equipment layout, including spatial dimensions for such equipment pursuant to generic requirements contained in BellCore (Telcordia) GR-63-Core and shall be responsible for constructing all special technical requirements associated with such equipment pursuant to Section 6.5 following.

3.2 Cages and Adjacent Arrangement Enclosures. BellSouth shall authorize the enclosure of Adelphia's equipment and facilities at Adelphia's option or if required by local building code. Adelphia must arrange with a BellSouth certified contractor to construct a collocation arrangement enclosure in accordance with BellSouth's guidelines and specifications and at its sole expense. BellSouth will provide guidelines and specifications upon request. Where local building codes require enclosure specifications more stringent than BellSouth's standard enclosure specification, Adelphia and Adelphia's BellSouth certified contractor must comply with local building code requirements. Adelphia's BellSouth certified contractor shall be responsible for filing and receiving any and all necessary permits and/or licenses for such construction. The Certified Vendor shall bill Adelphia directly for all work performed for Adelphia pursuant to this Attachment and BellSouth shall have no liability for nor responsibility to pay such charges imposed by the Certified Vendor. Adelphia must provide the local BellSouth building_contact with two Access Keys used to enter the locked enclosure. Except in case of emergency, BellSouth will not access Adelphia's locked enclosure prior to notifying Adelphia.

3.2.1 BellSouth has the right to review Adelphia's plans and specifications prior to allowing construction to start. BellSouth has the right to inspect the enclosure after construction to make sure it is designed and constructed according to BellSouth's guidelines and specifications and to require Adelphia to remove or correct at Adelphia's cost any structure that does not meet these standards.

3.3 Shared (Subleased) Caged Collocation. Adelphia may allow other telecommunications carriers to share Adelphia's caged collocation arrangement

pursuant to terms and conditions agreed to by Adelphia ("Host") and other telecommunications carriers ("Guests") and pursuant to this section with the following exceptions: (1) where local building code does not allow Shared (Subleased) Caged Collocation and (2) where the BellSouth central office premises is located within a leased space and BellSouth is not authorized by the lessor to offer such an option. The terms and conditions of the agreement between the Host and its Guests shall be written and a copy provided, on a confidential basis, to the BellSouth contact specified in Section 15 within ten (10) business days of the Guest's application and prior to any Firm Order. Further, said agreement shall incorporate by reference the rates, terms, and conditions of this Attachment between BellSouth and Adelphia.

3.3.1 Adelphia shall be the sole interface and responsible party to BellSouth for the purpose of submitting applications for initial and additional equipment placements of Guest; for assessment of rates and charges contained within this Attachment; and for the purposes of ensuring that the safety and security requirements of this Attachment are fully complied with by the Guest, its employees and agents. In the event the Host and Guest jointly submit an initial Application, only one Application Fee will be assessed. A separate initial Guest application shall require the assessment of a Subsequent Application Fee, as set forth in Exhibit A, if this application is not the initial application made for the arrangement. Notwithstanding the foregoing, Guest may arrange directly with BellSouth for the provision of the interconnecting facilities between BellSouth and Guest and for the provisions of the services and access to unbundled network elements.

3.3.2 Adelphia shall indemnify and hold harmless BellSouth from any and all claims, actions, causes of action, of whatever kind or nature arising out of the presence of Adelphia's Guests in the Collocation Space except for claims, actions, causes of action, of whatever kind or nature arising out of the interconnection between BellSouth and the Guest(s) or BellSouth's provision of access to unbundled network elements to the Guest(s) directly, or arising from the negligence, gross negligence, or willful misconduct of BellSouth.

3.4 Adjacent Collocation. BellSouth will provide adjacent collocation arrangements ("Adjacent Arrangement") where space within the Central Office is legitimately exhausted, subject to technical feasibility, where the Adjacent Arrangement does not interfere with access to existing or planned structures or facilities on the Central Office property and where permitted by zoning and other applicable state and local regulations. The Adjacent Arrangement shall be constructed or procured by Adelphia and in conformance with BellSouth's design and construction specifications. Further, Adelphia shall construct, procure, maintain and operate said Adjacent Arrangement(s) pursuant to all of the terms and conditions set forth in this Attachment. Rates shall be negotiated at the time of the request for Adjacent Collocation.

3.4.1 Should Adelphia elect such option, Adelphia must arrange with a BellSouth certified contractor to construct an Adjacent Arrangement structure in accordance with BellSouth's guidelines and specifications. BellSouth will provide guidelines and specifications upon request. Where local building codes require enclosure specifications more stringent than BellSouth's standard specification, Adelphia and Adelphia's contractor must comply with local building code requirements. Adelphia's contractor shall be responsible for filing and receiving any and all necessary zoning, permits and/or licenses for such construction. Adelphia's BellSouth Certified Vendor shall bill Adelphia directly for all work performed for

Adelphia pursuant to this Attachment and BellSouth shall have no liability for nor responsibility to pay such charges imposed by the Certified Vendor. Adelphia must provide the local BellSouth building contact with two cards, keys or other access device used to enter the locked enclosure. Except in cases of emergency, BellSouth shall not access Adelphia's locked enclosure prior to notifying Adelphia.

3.4.2 BellSouth maintains the right to review Adelphia's plans and specifications prior to construction of an Adjacent Arrangement(s). BellSouth may inspect the Adjacent Arrangement(s) following construction and prior to commencement, as defined in Section 4.1 following, to ensure the design and construction comply with BellSouth's guidelines and specifications. BellSouth may require Adelphia, at Adelphia's sole cost, to correct any deviations from BellSouth's guidelines and specifications found during such inspection(s), up to and including removal of the Adjacent Arrangement, within five (5) business days of BellSouth's inspection, unless the Parties mutually agree to an alternative time frame.

3.4.3 Adelphia shall provide a concrete pad, the structure housing the arrangement, HVAC, lighting, and all facilities that connect the structure (i.e. racking, conduits, etc.) to the BellSouth point of interconnection. At Adelphia's option, BellSouth shall provide an AC power source and access to physical collocation services and facilities subject to the same nondiscriminatory requirements as applicable to any other physical collocation arrangement.

3.4.4 BellSouth shall allow Shared (Subleased) Caged Collocation within an Adjacent Arrangement pursuant to the terms and conditions set forth in Section 3.3 proceeding.

3.5 Adelphia may seek a particular physical collocation arrangement, and is entitled to a presumption that such arrangement is technically feasible, if any local exchange company has deployed such collocation arrangement in any incumbent local exchange carrier premises.

4. OCCUPANCY

4.1 Commencement Date. The "Commencement Date" shall be the day Adelphia's equipment becomes operational as described in Article 4.2, following.

4.2 Occupancy. BellSouth will notify Adelphia in writing that the Collocation Space is ready for occupancy within 10 business days of the date the space is ready for occupancy. Adelphia must place operational telecommunications equipment in the Collocation Space and connect with BellSouth's network within one hundred eighty (180) days after receipt of such notice. Adelphia must notify BellSouth in writing that collocation equipment installation is complete and is operational with BellSouth's network. BellSouth may, at its option, not accept orders for interconnected service until receipt of such notice. If Adelphia fails to place operational telecommunications equipment in the Collocation Space within 180 calendar days and such failure continues for a period of thirty (30) days after receipt of written notice from BellSouth, then and in that event Adelphia's right to occupy the Collocation Space terminates and BellSouth shall have no further obligations to Adelphia with respect to said Collocation Space. However, for good cause shown, Adelphia may request and BellSouth will grant an extension of up to 30 days. Termination of Adelphia's rights to the Collocation Space pursuant to this paragraph shall not operate to release Adelphia from its obligation to reimburse BellSouth for all costs reasonably incurred by BellSouth in preparing the Collocation Space, but rather such obligation shall survive this Attachment. To the extent BellSouth places a subsequent

collocator in the Collocation Space within one year of the date Adelphia's right to occupy said Collocation Space terminates, BellSouth shall reimburse Adelphia an amortized amount of the costs incurred by BellSouth in preparing the Collocation Space based upon the amount of time the Collocation Space was unoccupied pursuant to this paragraph until its occupancy by the subsequent collocator. For purposes of this paragraph, Adelphia's telecommunications equipment will be deemed operational when cross-connected to BellSouth's network for the purpose of service provision.

4.3 Termination. Except where otherwise agreed to by the Parties, Adelphia may terminate occupancy in a particular Collocation Space upon thirty (30) days prior written notice to BellSouth. Upon termination of such occupancy, Adelphia at its expense shall remove its equipment and other property from the Collocation Space. Adelphia shall have thirty (30) days from the termination date to complete such removal, including the removal of all equipment and facilities of Adelphia's Guests; provided, however, that Adelphia shall continue payment of monthly fees to BellSouth until such date as Adelphia has fully vacated the Collocation Space. Should Adelphia fail to vacate the Collocation Space within thirty (30) days from the termination date, BellSouth shall have the right to remove the equipment and other property of Adelphia at Adelphia's expense and with no liability for damage or injury to Adelphia's property unless caused by the gross negligence or intentional misconduct of BellSouth. Upon expiration of this Attachment, Adelphia shall surrender the Collocation Space to BellSouth in the same condition as when first occupied by the Adelphia except for ordinary wear and tear. Adelphia shall be responsible for the cost of removing any enclosure, together with all support structures (e.g., racking, conduits), of an Adjacent Collocation arrangement at the termination of occupancy and restoring the grounds to their original condition, except for ordinary wear and tear.

5. USE OF COLLOCATION SPACE

5.1 Equipment Type. BellSouth permits the collocation of any type of equipment that is necessary for interconnection to BellSouth's network or for access to unbundled network elements in the provision of telecommunications services. Such equipment that is necessary for interconnection and access to unbundled network elements includes, but is not limited to transmission equipment including, but not limited to, optical terminating equipment and multiplexers, and digital subscriber line access multiplexers, routers, asynchronous transfer mode multiplexers, and remote switching modules. Nothing in this section requires BellSouth to permit collocation of equipment used solely to provide enhanced services.

5.1.1 Such equipment must at a minimum meet the following BellCore (Telcordia) Network Equipment Building Systems (NEBS) General Equipment Requirements: Criteria Level 1 requirements as outlined in the BellCore (Telcordia) Special Report SR-3580, Issue 1; equipment design spatial requirements per GR-63-CORE, Section 2; thermal heat dissipation per GR-063-CORE, Section 4, Criteria 77-79; acoustic noise per GR-063-CORE, Section 4, Criterion 128, and National Electric Code standards. If BellSouth denies collocation of Adelphia's equipment citing safety standards, BellSouth must provide to Adelphia within (5) five business days of the denial a list of all equipment that BellSouth locates within the premises in question together with an affidavit attesting that all of the equipment meets or exceeds the safety standard that BellSouth contends Adelphia's equipment fails to meet.

5.1.2 Adelphia shall not use the Collocation Space for marketing purposes nor shall it place any identifying signs or markings in the area surrounding the Collocation Space or on the grounds of the central office premises.

5.1.3 Adelphia shall place a plaque or other identification affixed to Adelphia's equipment necessary to identify Adelphia's equipment, including a list of emergency contacts with telephone numbers.

5.2 Entrance Facilities. Adelphia may elect to place Adelphia-owned or Adelphia-leased fiber entrance facilities into the Collocation Space. BellSouth will designate the point of interconnection in close proximity to the Central Office building housing the Collocation Space, such as an entrance manhole or a cable vault which are physically accessible by both parties. Adelphia will provide and place fiber cable at the point of interconnection of sufficient length to be pulled through conduit and into the splice location. Adelphia will provide and install a sufficient length of fire retardant riser cable, to which the entrance cable will be spliced, which will extend from the splice location to the Adelphia's equipment in the Collocation Space. In the event Adelphia utilizes a non-metallic, riser-type entrance facility, a splice will not be required. Adelphia must contact BellSouth for instructions prior to placing the entrance facility cable in the manhole. Adelphia is responsible for maintenance of the entrance facilities At Adelphia's option BellSouth will accommodate where technically feasible a microwave entrance facility pursuant to separately negotiated terms and conditions.

5.2.1 Dual Entrance. BellSouth will provide at least two interconnection points at each central office premises where there are at least two such interconnection points available and where capacity exists. Upon receipt of a request for physical collocation under this Attachment, BellSouth shall provide Adelphia with information regarding BellSouth's capacity to accommodate dual entrance facilities. If conduit in the serving manhole(s) is available and is not reserved for another purpose for utilization within 12 months of the receipt of an application for collocation, BellSouth will make the requested conduit space available for installing a second entrance facility to Adelphia's arrangement. The location of the serving manhole(s) will be determined at the sole discretion of BellSouth. Where dual entrance is not available due to lack of capacity, BellSouth will so state in the Application Response.

5.2.2 Shared Use. Adelphia may utilize spare capacity on an existing Interconnector entrance facility for the purpose of providing an entrance facility to another Adelphia collocation arrangement within the same BellSouth Central Office. Adelphia must arrange with BellSouth for BellSouth to splice the utilized entrance facility capacity to Adelphia-provided riser cable.

5.3 Splicing in the Entrance Manhole. Although not generally permitted, should Adelphia request a splice to occur in the entrance manhole(s), BellSouth, at its sole discretion, may grant such a request, provided that BellSouth will not unreasonably withhold approval of requests to make such a splice. When the request for a splice is granted to Adelphia by BellSouth, Adelphia shall ensure its employees or agents entering and/or performing work in the entrance manhole(s) are trained and comply with BellSouth procedures and OSHA requirements regarding access to manholes and that BellSouth personnel are notified and present for all entrances and work performed in the entrance manhole(s). Manhole covers shall be properly closed and secured at the conclusion of entry and/or work. Advance notification to BellSouth shall occur at a minimum of 48 hours prior to desired entry for normal work activities and at a minimum of 2 hours prior to desired entry in an out of service condition.

5.4 Demarcation Point. BellSouth will designate the point(s) of demarcation between Adelphia's equipment and/or network and BellSouth's network. Each party will be responsible for maintenance and operation of all equipment/facilities on its side of the demarcation point. For 2-wire and 4-wire connections to BellSouth's network, the demarcation point shall be a common block on the BellSouth designated conventional distributing frame. Adelphia shall be responsible for providing, and Adelphia's BellSouth Certified Vendor shall be responsible for installing and properly labelling/stenciling, the common block, and necessary cabling pursuant to Section 6.4. For all other terminations BellSouth shall designate a demarcation point on a per arrangement basis. Adelphia or its agent must perform all required maintenance to equipment/facilities on its side of the demarcation point, pursuant to subsection 5.5, following, and may self-provision cross-connects that may be required within the collocation space to activate service requests. At Adelphia's option, a Point of Termination (POT) bay or frame may be placed in the Collocation Space.

5.5 Adelphia's Equipment and Facilities. Adelphia, or if required by this Attachment, Adelphia's BellSouth certified vendor, is solely responsible for the design, engineering, installation, testing, provisioning, performance, monitoring, maintenance and repair of the equipment and facilities used by Adelphia. Such equipment and facilities may include but are not limited to cable(s); equipment; and point of termination connections.

5.6 Co-Carrier Cross-connect. In addition to, and not in lieu of, obtaining interconnection with, or access to, BellSouth telecommunications services, unbundled network elements, and facilities, Adelphia may directly connect to other Interconnectors within the designated BellSouth Central Office (including to its other virtual or physical collocated arrangements) through facilities owned by Adelphia, or the other Interconnector(s) Adelphia is directly connecting to, or through BellSouth facilities designated by Adelphia, at Adelphia's option. Such connections to other carriers may be made using either optical or electrical facilities. Adelphia may deploy such optical or electrical connections directly between its own facilities and the facilities of other Interconnector(s) without being routed through BellSouth equipment.

5.6.1 If Adelphia requests a co-Carrier cross-connect after the initial installation, Adelphia must submit an application with a Subsequent Application Fee. Adelphia must use a Certified Vendor to place the co-Carrier cross connect, except in cases where the Adelphia equipment and the equipment of the other Interconnector are located within contiguous collocation spaces. In cases where Adelphia's equipment and the equipment of the other Interconnector are located in contiguous collocation spaces, Adelphia will have the option to deploy the co-Carrier cross connects between the sets of equipment. Where cable support structure exists for such connection there will be a recurring charge per linear foot of support structure used. When cable support structures do not exist and must be constructed a non-recurring charge for the individual case will be assessed. If Adelphia requests a co-carrier cross-connect after the initial installation, Adelphia must submit an application. The applicable nonrecurring fee in Exhibit A for co-carrier cross connections shall apply and an application fee shall not apply. Adelphia must use a BellSouth Certified Supplier to place the co-carrier cross-connect, except in cases where Adelphia's equipment and the equipment of the other interconnector are located within contiguous Collocation Spaces and the co-carrier cross-connect is not routed over or through BellSouth space or the space of other collocators. In cases where Adelphia's equipment and the equipment of the other interconnector are located in contiguous Collocation Spaces, Adelphia will have the option to deploy the co-carrier cross connects between the sets of equipment. Cable support charges shall be assessed per linear foot of support structure used

5.7 Easement Space. From time to time BellSouth may require access to the Collocation Space. BellSouth retains the right to access such space for the purpose of making BellSouth equipment and building modifications (e.g., running, altering or removing racking, ducts, electrical wiring, HVAC, and cables). BellSouth will give reasonable notice to Adelphia when access to the Collocation Space is required. Adelphia may elect to be present whenever BellSouth performs work in the Collocation Space. The Parties agree that Adelphia will not bear any of the expense associated with this work.

5.8 Access. Pursuant to Section 11, Adelphia shall have access to the Collocation Space twenty-four (24) hours a day, seven (7) days a week. Adelphia agrees to provide the name, social security number, and date of birth of each employee, contractor, or agents provided with Access Keys or cards ("Access Keys") prior to the issuance of said Access Keys. Access Keys shall not be duplicated under any circumstances. Adelphia agrees to be responsible for all Access Keys and for the return of all said Access Keys in the possession of Adelphia employees, contractors, Guests, or agents after termination of the employment relationship, contractual obligation with Adelphia or upon the termination of this Attachment or the termination of occupancy of an individual collocation arrangement.

5.8.1 Lost or Stolen Access Keys. Adelphia shall notify BellSouth in writing immediately in the case of lost or stolen Access Keys. Adelphia will pay BellSouth \$250.00 per Access Key(s) lost or stolen. Should it become necessary for BellSouth to re-key buildings as a result of a lost Access Key(s) or for failure to return an Access Key(s), Adelphia shall pay for all reasonable costs associated with the re-keying.

5.9 Interference or Impairment. Notwithstanding any other provisions of this Attachment, equipment and facilities placed in the Collocation Space shall not interfere with or impair service provided by BellSouth or by any other Interconnector located in the Central Office; shall not endanger or damage the facilities of BellSouth or of any other Interconnector, the Collocation Space, or the Central Office; shall not compromise the privacy of any communications carried in, from, or through the Central Office; and shall not create an unreasonable risk of injury or death to any individual or to the public. If BellSouth reasonably determines that any equipment or facilities of Adelphia violates the provisions of this paragraph, BellSouth shall give written notice to Adelphia, which notice shall direct Adelphia to cure the violation within forty-eight (48) hours of Adelphia's actual receipt of written notice or, at a minimum, to commence curative measures within 24 hours and to exercise reasonable diligence to complete such measures as soon as possible thereafter. After receipt of the notice, the parties agree to consult immediately and, if necessary, to inspect the arrangement. If Adelphia fails to take curative action within 48 hours or if the violation is of a character which poses an immediate and substantial threat of damage to property, injury or death to any person, or interference/impairment of the services provided by BellSouth or any other interconnector, then and only in that event BellSouth may take such action as it deems appropriate to correct the violation, including without limitation the interruption of electrical power to Adelphia's equipment. BellSouth will endeavor, but is not required, to provide notice to Adelphia prior to taking such action and shall have no liability to Adelphia for any damages arising from such action, except to the extent that such action by BellSouth constitutes willful misconduct or gross negligence.

5.10 Personalty and its Removal. Subject to requirements of this Attachment, Adelphia may place or install in or on the Collocation Space such facilities and equipment, including storage for and spare equipment, as it deems desirable for the conduct of business;

Provided that such equipment is telecommunications equipment, does not violate floor loading requirements, imposes or could impose or contains or could contain environmental conditions or hazards. Personal property, facilities and equipment placed by Adelphia in the Collocation Space shall not become a part of the Collocation Space, even if nailed, screwed or otherwise fastened to the Collocation Space, but shall retain their status as personalty and may be removed by Adelphia at any time. Any damage caused to the Collocation Space by Adelphia's employees, agents or representatives during the removal of such property shall be promptly repaired by Adelphia at its expense.

5.11 Alterations. In no case shall Adelphia or any person acting on behalf of Adelphia make any rearrangement, modification, improvement, addition, repair, or other alteration which could affect in any way space, power, HVAC and/or safety considerations to the Collocation Space or the BellSouth Central Office without the written consent of BellSouth, which consent shall not be unreasonably withheld. The cost of any such specialized alterations shall be paid by Adelphia. Any material rearrangement, modification, improvement, addition, repair, or other alteration shall require a Subsequent Application and fee, pursuant to sub-section 6.1.2.

5.12 Janitorial Service. Adelphia shall be responsible for the general upkeep and cleaning of the Caged Collocation Space and shall arrange directly with a BellSouth certified contractor for janitorial services. BellSouth shall provide a list of such contractors on a site-specific basis upon request.

6. ORDERING AND PREPARATION OF COLLOCATION SPACE

6.1 Application for Space. Adelphia shall submit an application document when Adelphia or Adelphia's Guest(s), as defined in Section 3.3, desires to request or modify the use of the Collocation Space.

6.1.1 Initial Application. For Adelphia or Adelphia's Guest(s) initial equipment placement, Adelphia shall submit to BellSouth a complete and accurate Application and Inquiry document (Bona Fide Application), together with payment of the Application Fee as stated in Exhibit A. The Bona Fide Application shall contain a detailed description and schematic drawing of the equipment to be placed in Adelphia's Collocation Space(s) and an estimate of the amount of square footage required.

6.1.2 Subsequent Application Fee. In the event Adelphia or Adelphia's Guest(s) desire to modify the use of the Collocation Space, Adelphia shall complete an Application document detailing all information regarding the modification to the Collocation Space together with payment of the minimum Subsequent Application Fee as stated in Exhibit A. Said minimum Subsequent Application Fee shall be considered a partial payment of the applicable Subsequent Application Fee which shall be calculated as set forth below. BellSouth shall determine what modifications, if any, to the Central Office premises are required to accommodate the change requested by Adelphia in the Application. Such necessary modifications to the Central Office premises may include but are not limited to, floor loading changes, changes necessary to meet HVAC requirements, changes to power plant requirements, and equipment additions. The fee paid by Adelphia for its request to modify the use of the Collocation Space shall be dependent upon the modification requested. Where the subsequent application does not require provisioning or construction work by BellSouth, no Subsequent Application Fee will be required and the pre-paid fee shall be refunded to Adelphia. The fee for an application where the modification requested has limited effect (e.g., does not

require capital expenditure by BellSouth) shall be the Subsequent Application Fee as set forth in Exhibit A. All other modifications shall require a Subsequent Application Fee assessed at the applicable application fee. In the event such modifications require the assessment of a full Application Fee as set forth in Exhibit A, the outstanding balance shall be due by Adelphia within 30 calendar days following Adelphia's receipt of a bill or invoice from BellSouth.

6.2 Application Response. In addition to the notice of space availability pursuant to Section 2.1, BellSouth will respond within ten (10) business days of receipt of an Application whether the Application is Bona Fide, and if it is not Bona Fide, the items necessary to cause the Application to become Bona Fide. BellSouth will not classify an Application as not Bona Fide for de minimis or clerical errors which do not affect the ability of Application to be processed. When space has been determined to be available, BellSouth will provide a comprehensive written response within thirty (30) business days of receipt of a complete application. When multiple applications are submitted within a fifteen business day window, BellSouth will respond to the applications as soon as possible, but no later than the following: within thirty (30) business days for applications 1-5; within thirty-six (36) business days for applications 6-10; within forty-two (42) business days for applications 11-15. Response intervals for multiple applications submitted within the same timeframe for the same state in excess of 15 must be negotiated. All negotiations shall consider the total volume from all requests from telecommunications companies for collocation. The Application Response will detail whether the amount of space requested is available or if the amount of space requested is not available, the amount of space that is available. The response will also include the configuration of the space. When BellSouth's response includes an amount of space less than that requested by Adelphia or differently configured, Adelphia must amend its application to reflect the actual space available prior to submitting a Bona Fide Firm Order.

6.2.1 If BellSouth knows at the time of providing the Application Response that local building code does not allow the provisioning of the requested form of collocation (e.g. cageless and shared), BellSouth will notify Adelphia of such building code restrictions. If BellSouth determines after the Application Response that local building code does not allow the provisioning of the requested form of collocation, BellSouth will provide Adelphia written notice of such restriction.

6.3 Bona Fide Firm Order. Adelphia shall indicate its intent to proceed with equipment installation in a BellSouth Central Office by submitting a Bona Fide Firm Order to BellSouth. A Bona Fide Firm Order requires Adelphia to complete the Application/Inquiry process described in Subsection 6.1, preceding, and submit the Expanded Interconnection Bona Fide Firm Order document (BSTEI-1P-F) indicating acceptance of the written application response provided by BellSouth ("Bona Fide Firm Order") and all appropriate fees. The Bona Fide Firm Order must be received by BellSouth no later than thirty (30) calendar days after BellSouth's response to Adelphia's Application/Inquiry. If Adelphia makes changes to its application in light of BellSouth's written Application Response, BellSouth will be required to re-evaluate and respond to the change(s). In this event, BellSouth's provisioning interval will not start until the re-evaluation and response to the change(s) is complete and the Bona Fide Firm Order is received by BellSouth and all appropriate fees and duties have been executed. If BellSouth needs to reevaluate Adelphia's application as a result of changes requested by Adelphia to Adelphia's original application, then BellSouth will charge Adelphia a fee based upon the additional engineering hours required to do the reassessment. Major changes such as requesting additional space or adding additional equipment may require Adelphia to resubmit the application with an application fee.

6.3.1 BellSouth will establish a firm order date, per request, based upon the date BellSouth is in receipt of a Bona Fide Firm Order. BellSouth will acknowledge the receipt of Adelphia's Bona Fide Firm Order within five (5) business days of receipt indicating that the Bona Fide Firm Order has been received. A BellSouth response to a Bona Fide Firm Order will include a Firm Order Confirmation containing the firm order date.

6.3.2 BellSouth will permit one accompanied site visit to Adelphia's designated collocation arrangement location after receipt of the Bona Fide Firm Order without charge to Adelphia.

6.3.3 Space preparation for the Collocation Space will not begin until BellSouth receives the Bona Fide Firm Order and all applicable fees.

6.3.4 Except for a site visit under 6.3.2., Adelphia must submit to BellSouth the completed Access Control Request Form (RF-2906-A) for all employees or agents requiring access to the BellSouth Central Office a minimum of 30 calendar days prior to the date Adelphia desires access to the Collocation Space.

6.4 Construction and Provisioning Interval. BellSouth will negotiate construction and provisioning intervals per request on an individual case basis. Excluding the time interval required to secure the appropriate government licenses and permits, BellSouth will use best efforts to complete construction for collocation arrangements under ordinary conditions as soon as possible and within a maximum of 90 business days from receipt of a complete and accurate Bona Fide Firm Order. Ordinary conditions are defined as space available with only minor changes to support systems required, such as but not limited to, HVAC, cabling and the power plant(s). Excluding the time interval required to secure the appropriate government licenses and permits, BellSouth will use best efforts to complete construction of all other collocation space ("extraordinary conditions") within 130 business days of the receipt of a complete and accurate Bona Fide Firm Order. Extraordinary conditions are defined to include but are not limited to major BellSouth equipment rearrangement or addition; power plant addition or upgrade; major mechanical addition or upgrade; major upgrade for ADA compliance; environmental hazard or hazardous materials abatement.

6.4.1 Joint Planning Meeting. Unless otherwise agreed to by the Parties, a joint planning meeting or other method of joint planning between BellSouth and Adelphia will commence within a maximum of 15 business days from BellSouth's receipt of a Bona Fide Firm Order and the payment of agreed upon fees. At such meeting, the Parties will agree to the preliminary design of the Collocation Space and the equipment configuration requirements as reflected in the Application and affirmed in the Bona Fide Firm Order. The Collocation Space Completion time period will be provided to Adelphia during the joint planning meeting or as soon as possible thereafter. BellSouth will complete all design work following the joint planning meeting.

6.4.2 Permits. Each Party or its agents will diligently pursue filing for the permits required for the scope of work to be performed by that Party or its agents within 7 business days of the completion of finalized construction designs and specifications.

6.4.3 Acceptance Walk Through. Adelphia and BellSouth will complete an acceptance walk through of each Collocation Space requested from BellSouth by Adelphia. BellSouth will correct at no cost to Adelphia any deviations to Adelphia's original or jointly

amended requirements within five (5) business days after the walk through, unless the Parties jointly agree upon a different time frame.

6.5 Use of Certified Vendor. Adelphia shall select a vendor which has been approved as a BellSouth Certified Vendor to perform all engineering and installation work required in the Collocation Space. In some cases, Adelphia must select separate BellSouth Certified Vendors for transmission equipment, switching equipment and power equipment. BellSouth shall provide Adelphia with a list of Certified Vendors upon request. The Certified Vendor(s) shall be responsible for installing Adelphia's equipment and components, installing co-carrier cross connects, extending power cabling to the BellSouth power distribution frame, performing operational tests after installation is complete, and notifying BellSouth's equipment engineers and Adelphia upon successful completion of installation. The Certified Vendor shall bill Adelphia directly for all work performed for Adelphia pursuant to this Attachment and BellSouth shall have no liability for nor responsibility to pay such charges imposed by the Certified Vendor. BellSouth shall consider certifying Adelphia or any vendor proposed by Adelphia.

6.6 Alarm and Monitoring. BellSouth shall place environmental alarms in the Central Office for the protection of BellSouth equipment and facilities. Adelphia shall be responsible for placement, monitoring and removal of environmental and equipment alarms used to service Adelphia's Collocation Space. Upon request, BellSouth will provide Adelphia with applicable tariffed service(s) to facilitate remote monitoring of collocated equipment by Adelphia. Both parties shall use best efforts to notify the other of any verified environmental hazard known to that party. The parties agree to utilize and adhere to the Environmental Hazard Guidelines identified as Exhibit B attached hereto.

6.7 Basic Telephone Service. Upon request of Adelphia, BellSouth will provide basic telephone service to the Collocation Space under the rates, terms and conditions of the current tariff offering for the service requested.

6.8 Space Preparation. Space preparation fees consist of a nonrecurring charge for Firm Order Processing and monthly recurring charges for Central Office Modifications, assessed per arrangement, per square foot, and Common Systems Modifications, assessed per arrangement, per square foot for cageless and per cage for caged collocation. Adelphia shall remit payment of the nonrecurring Firm Order Processing Fee coincident with submission of a Bona Fide Firm Order. The recurring charges for space preparation apply beginning on the date on which BellSouth releases the Collocation Space for occupancy or on the date Adelphia first occupies the Collocation Space, whichever is sooner. The charges recover the costs associated with preparing the Collocation Space, which includes survey, engineering of the Collocation Space, design and modification costs for network, building and support systems. Additional engineering charges may apply as described in Section 6.3. In the event Adelphia opts for cageless space, the space preparation fees will be assessed based on the total floor space dedicated to Adelphia as prescribed in Section 7.5.

6.9 Space Preparation Fee in Georgia. In Georgia, the Space Preparation Fee is a one-time fee, assessed per arrangement, per location. It recovers a portion of costs associated with preparing the Collocation Space, which includes survey, engineering of the Collocation Space, design and modification costs for network, power, building and support systems. This is a set fee of \$100 per square foot as established by the Georgia Public Service Commission Order in Docket No. 7061-U. Additional engineering charges may apply as described in Section

6.3. In the event Adelphia opts for non-enclosed space, the space preparation fee will be assessed based on the total floor space dedicated to Adelphia as prescribed in Section 7.

6.10 Space Preparation Fee in North Carolina. In North Carolina, space preparation fees consist of monthly recurring charges for Central Office Modifications, assessed per arrangement, per square foot; Common Systems Modifications, assessed per arrangement, per square foot for cageless and per cage for caged collocation; and Power, assessed per the nominal -48V DC ampere requirements specified by Adelphia on the Bona Fide Application. These fees were established by the North Carolina Utilities Commission in Docket No. P100-Sub 133d. The space preparation charges apply beginning on the date on which BellSouth releases the Collocation Space for occupancy or on the date Adelphia first occupies the Collocation Space, whichever is sooner. The charges recover the costs associated with preparing the Collocation Space, which includes survey, engineering of the Collocation Space, design and modification costs for network, building and support systems. Additional engineering charges may apply as described in Exhibit A. In the event Adelphia opts for cageless space, the space preparation fees will be assessed based on the total floor space dedicated to Adelphia as described in Section 7.4.

6.11 The nonrecurring charge for Firm Order Processing and monthly recurring charges for Central Office Modifications set forth in Sections 6.8, 6.9, and 6.10 apply only to collocation arrangements ordered by Adelphia on or after the effective date of this agreement. In no instance shall the monthly recurring charges for Central Office Modifications set forth in Sections 6.8, 6.9, and 6.10 apply to collocation arrangements ordered by Adelphia prior to the effective date of this Agreement.

6.12 Virtual Collocation Transition. BellSouth offers Virtual Collocation pursuant to the rates, terms and conditions set forth in its F.C.C. Tariff No. 1. For the interconnection to BellSouth's network and access to BellSouth unbundled network elements, Adelphia may purchase 2-wire and 4-wire Cross-Connects as set forth in Exhibit A, and Adelphia may place within its Virtual Collocation arrangements the telecommunications equipment set forth in Section 5.1. In the event physical collocation space was previously denied at a location due to technical reasons or space limitations, and that physical collocation space has subsequently become available, Adelphia may transition its virtual collocation arrangements to physical collocation arrangements and pay the appropriate non-recurring fees for physical collocation and for the rearrangement or reconfiguration of services terminated in the virtual collocation arrangement. BellSouth will authorize the conversion of virtual collocation arrangements to physical collocation arrangements without requiring the relocation of the virtual arrangement where there are no extenuating circumstances or technical reasons that would prevent the arrangement from becoming a safety hazard within the Premises or otherwise being in conformance with the terms and conditions of this Attachment and where (1) there is no change to the arrangement; and (2) the conversion of the virtual arrangement would not cause the arrangement to be located in the area of the Premises reserved for BellSouth's forecast of future growth; and (3) due to the location of the virtual collocation arrangement, the conversion of said arrangement to a physical arrangement would not impact BellSouth's ability to secure its own facilities. Notwithstanding the foregoing, if the BellSouth Premises is at or nearing space exhaust, BellSouth may authorize the conversion of the virtual arrangement to a physical arrangement even though BellSouth could no longer secure its own facilities.

In the event that BellSouth knows when additional space for physical collocation may become available at the location requested by Adelphia, such information will be provided to Adelphia in BellSouth's written denial of physical collocation. To the extent that (i) physical collocation

space becomes available to Adelphia within 180 days of BellSouth's written denial of Adelphia's request for physical collocation, and (ii) Adelphia was not informed in the written denial that physical collocation space would become available within such 180 days, then Adelphia may transition its virtual collocation arrangement to a physical collocation arrangement and will receive a credit for any nonrecurring charges previously paid for such virtual collocation. Adelphia must arrange with a BellSouth certified vendor for the relocation of equipment from its virtual collocation space to its physical collocation space and will bear the cost of such relocation.

6.13 Cancellation. If, at anytime, Adelphia cancels its order for the Collocation Space(s), Adelphia will reimburse BellSouth for any reasonable expenses incurred up to the date that written notice of the cancellation is received. In no event will the level of reimbursement under this paragraph exceed the maximum amount Adelphia would have otherwise paid for work undertaken by BellSouth if no cancellation of the order had occurred.

6.14 Licenses. Adelphia, at its own expense, will be solely responsible for obtaining from governmental authorities, and any other appropriate agency, entity, or person, all rights, privileges, and licenses necessary or required to operate as a provider of telecommunications services to the public or to occupy the Collocation Space.

7. RATES AND CHARGES

7.1 Non-recurring Fees. In addition to the Application Fee referenced in Section 6, preceding, Adelphia shall remit payment of a Cable Installation Fee and one-half (1/2) of the estimated Space Preparation Fee, as applicable, coincident with submission of a Bona Fide Firm Order. The outstanding balance of the actual Space Preparation Fee shall be due thirty (30) calendar days following Adelphia's receipt of a bill or invoice from BellSouth. Once the installation of the initial equipment arrangement is complete, a subsequent application fee may apply (as described in Subsection 7.4, when Adelphia requests a modification to the arrangement.

7.2 Documentation. BellSouth shall provide documentation to establish the actual Space Preparation Fee. The Space Preparation Fee will be pro rated as prescribed in Section 6, preceding.

7.3 Cable Installation. Cable Installation Fee(s) are assessed per entrance fiber placed.

7.4 Floor Space. The floor space charge includes reasonable charges for lighting, heat, air conditioning, ventilation and other allocated expenses associated with maintenance of the Central Office but does not include amperage necessary to power Adelphia's equipment. When the Collocation Space is enclosed, Adelphia shall pay floor space charges based upon the number of square feet so enclosed. When the Collocation Space is not enclosed, Adelphia shall pay floor space charges based upon the following floor space calculation: [(depth of the equipment lineup in which the rack is placed) + (0.5 x maintenance aisle depth) + (0.5 x wiring aisle depth)] X (width of rack and spacers). For purposes of this calculation, the depth of the equipment lineup shall consider the footprint of equipment racks plus any equipment overhang. BellSouth will assign unenclosed Collocation Space in conventional equipment rack lineups where feasible. In the event Adelphia's collocated equipment requires special cable racking, isolated grounding or other treatment which prevents placement within conventional equipment

rack lineups, Adelphia shall be required to request an amount of floor space sufficient to accommodate the total equipment arrangement. Floor space charges are due beginning with the date on which BellSouth releases the Collocation Space for occupancy or on the date Adelphia first occupies the Collocation Space, whichever is sooner.

7.5 Power. BellSouth shall supply -48 Volt (-48V) DC power for Adelphia's Collocation Space within the central office premises and shall make available AC power at Adelphia's option for Adjacent Arrangement collocation.

7.5.1 Recurring charges for -48V DC power will be assessed per ampere per month based upon the BellSouth Certified Supplier engineered and installed power feed fused ampere capacity. Rates include redundant feeder fuse positions (A&B) and common cable rack to Adelphia's equipment or space enclosure. When obtaining power from a BDFB, fuses and power cables (A&B) must be engineered (sized), and installed by Adelphia's BellSouth Certified Supplier. When obtaining power from a BellSouth power board, power cables (A&B) must be engineered (sized), and installed by Adelphia's BellSouth Certified power Supplier. Adelphia is responsible for contracting with a BellSouth Certified Supplier for power distribution feeder cable runs from a BellSouth BDFB or power board to Adelphia's equipment. Determination of the BellSouth BDFB or BellSouth power board as the power source will be made at BellSouth's sole, but reasonable, discretion. The BellSouth Certified Supplier contracted by Adelphia must provide BellSouth a copy of the engineering power specification prior to the day on which Adelphia's equipment becomes operational ("Commencement Date"). BellSouth will provide the common power feeder cable support structure between the BellSouth BDFB or power board and Adelphia's arrangement area. Adelphia shall contract with a BellSouth Certified Supplier who will be responsible for the following: dedicated power cable support structure within Adelphia's arrangement; power cable feeds; terminations of cable. Any terminations at a BellSouth power board must be performed by a BellSouth Certified power Supplier. Adelphia shall comply with all applicable National Electric Code (NEC), BellSouth TR73503, Telcordia (BellCore) and ANSI Standards regarding power cabling.

7.5.2 If BellSouth has not previously invested in power plant capacity for collocation at a specific site, Adelphia has the option to add its own dedicated power plant; provided, however, that such work shall be performed by a BellSouth Certified Supplier who shall comply with BellSouth's guidelines and specifications. Where the addition of Adelphia's dedicated power plant results in construction of a new power plant room, upon termination of Adelphia's right to occupy collocation space at such site, Adelphia shall have the right to remove its equipment from the power plant room, but shall otherwise leave the room intact.

7.6 Security Escort. A security escort will be required whenever Adelphia or its approved agent desires access to the entrance manhole or must have access to the Central Office Premises after the one accompanied site visit allowed pursuant to subsection 6.2.2 prior to completing BellSouth's Security Training requirements and/or prior to Space Acceptance. Rates for a security escort are assessed in one-half (1/2) hour increments according to the schedule appended hereto as Exhibit A.

7.7 Rate "True-Up." The Parties agree that the prices reflected as interim herein shall be "trued-up" (up or down) based on final prices either determined by further agreement or by final order, including any appeals, in a proceeding involving BellSouth before the regulatory authority for the state in which the services are being performed or any other body having jurisdiction over this agreement (hereinafter "Commission"). Under the "true-up" process, the interim price for each service shall be multiplied by the volume of that service purchased to

arrive at the total interim amount paid for that service ("Total Interim Price"). The final price for that service shall be multiplied by the volume purchased to arrive at the total final amount due ("Total Final Price"). The Total Interim Price shall be compared with the Total Final Price. If the Total Final Price is more than the Total Interim Price, Adelphia shall pay the difference to BellSouth. If the Total Final Price is less than the Total Interim Price, BellSouth shall pay the difference to Adelphia. Each party shall keep its own records upon which a "true-up" can be based and any final payment from one party to the other shall be in an amount agreed upon by the Parties based on such records. In the event of any disagreement as between the records or the Parties regarding the amount of such "true-up," the Parties agree that the Commission shall be called upon to resolve such differences.

7.8 Other. If no rate is identified in the contract, the rate for the specific service or function will be negotiated by the parties upon request by either party. Payment of all other charges under this Attachment shall be due thirty (30) days after receipt of the bill (payment due date). Adelphia will pay a late payment charge of one and one-half percent (1-1/2%) assessed monthly on any balance which remains unpaid after the payment due date.

8. INSURANCE

8.1 Adelphia shall, at its sole cost and expense, procure, maintain, and keep in force insurance as specified in this Section and underwritten by insurance companies licensed to do business in the states applicable under this Attachment and having a BEST Insurance Rating of B ++ X (B ++ ten).

8.2 Adelphia shall maintain the following specific coverage:

8.2.1 Commercial General Liability coverage in the amount of ten million dollars (\$10,000,000.00) or a combination of Commercial General Liability and Excess/Umbrella coverage totaling not less than ten million dollars (\$10,000,000.00). BellSouth shall be named as an ADDITIONAL INSURED on ALL Adelphia applicable policies as specified herein.

8.2.2 Statutory Workers Compensation coverage and Employers Liability coverage in the amount of one hundred thousand dollars (\$100,000.00) each accident, one hundred thousand dollars (\$100,000.00) each employee by disease, and five hundred thousand dollars (\$500,000.00) policy limit by disease.

8.3 The limits set forth in Subsection 6.2 above may be increased by BellSouth from time to time during the term of this Attachment upon thirty (30) days notice to Adelphia to at least such minimum limits as shall then be customary with respect to comparable occupancy of BellSouth structures.

8.4 All policies purchased by Adelphia shall be deemed to be primary and not contributing to or in excess of any similar coverage purchased by BellSouth. All insurance must be in effect on or before the date equipment is delivered to BellSouth's Central Office and shall remain in effect for the term of this Attachment or until all Adelphia's property has been removed from BellSouth's Central Office, whichever period is longer. If Adelphia fails to maintain required coverage, BellSouth may pay the premiums thereon and seek reimbursement of same from Adelphia.

8.5 Adelphia shall submit certificates of insurance reflecting the coverage required pursuant to this Section a minimum of ten (10) days prior to the commencement of any work in the Collocation Space. Failure to meet this interval may result in construction and equipment installation delays. Adelphia shall arrange for BellSouth to receive thirty (30) days advance notice of cancellation from Adelphia's insurance company. Adelphia shall forward a certificate of insurance and notice of cancellation to BellSouth at the following address:

BellSouth Telecommunications, Inc.
Attn.: Risk Management Coordinator
600 N. 19th Street, 18B3
Birmingham, Alabama 35203

8.6 Adelphia must conform to recommendations made by BellSouth's fire insurance company to the extent BellSouth has agreed to, or shall hereafter agree to, such recommendations.

8.7 BellSouth shall procure and maintain insurance coverage, or will maintain a program of self insurance, at equivalent or higher levels as those imposed upon Adelphia under this section.

8.8 Failure to comply with the provisions of this Section will be deemed a material breach of this Attachment.

9. MECHANICS LIENS

9.1 If any mechanics lien or other liens shall be filed against property of either party (BellSouth or Adelphia), or any improvement thereon by reason of or arising out of any labor or materials furnished or alleged to have been furnished or to be furnished to or for the other party or by reason of any changes, or additions to said property made at the request or under the direction of the other party, the other party directing or requesting those changes shall, within thirty (30) days after receipt of written notice from the party against whose property said lien has been filed, either pay such lien or cause the same to be bonded off the affected property in the manner provided by law. The party causing said lien to be placed against the property of the other shall also defend, at its sole cost and expense, on behalf of the other, any action, suit or proceeding which may be brought for the enforcement of such liens and shall pay any damage and discharge any judgment entered thereon.

10. INSPECTIONS

10.1 BellSouth may conduct an inspection of Adelphia's equipment and facilities in the Collocation Space(s) prior to the activation of facilities between Adelphia's equipment and equipment of BellSouth. If Adelphia later adds equipment, BellSouth may conduct routine inspections at reasonable intervals mutually agreed upon by the Parties. BellSouth shall provide Adelphia with a minimum of forty-eight (48) hours or two (2) business days, whichever is greater, advance notice of all such inspections. All costs of such inspection shall be borne by BellSouth.

11. SECURITY AND SAFETY REQUIREMENTS

11.1 The security and safety requirements set forth in this section are as stringent as the security requirements BellSouth maintains at its own premises either for their own employees or for authorized contractors. Only BellSouth employees, BellSouth certified vendors and authorized employees, authorized Guests, pursuant to Section 3.3, preceding, or authorized agents of Adelphia will be permitted in the BellSouth Central Office. Adelphia shall provide its employees and agents with picture identification which must be worn and visible at all times while in the Collocation Space or other areas in or around the Central Office. The photo Identification card shall bear, at a minimum, the employee's name and photo, and the Adelphia name. BellSouth reserves the right to remove from its premises any employee of Adelphia not possessing identification issued by Adelphia. Adelphia shall hold BellSouth harmless for any damages resulting from such removal of its personnel from BellSouth premises. Adelphia shall be solely responsible for ensuring that any Guest of Adelphia is in compliance with all subsections of this Section 11.

11.1.1 Adelphia will be required, at its own expense, to conduct a statewide investigation of criminal history records for each Adelphia employee being considered for work on the BellSouth Central Office, for the states/counties where the Adelphia employee has worked and lived for the past five years. Where state law does not permit statewide collection or reporting, an investigation of the applicable counties is acceptable.

11.1.2 Adelphia will be required to administer to their personnel assigned to the BellSouth Central Office security training either provided by BellSouth, or meeting criteria defined by BellSouth.

11.1.3 Adelphia shall not assign to the BellSouth Central Office any personnel with records of felony criminal convictions. Adelphia shall not assign to the BellSouth Central Office any personnel with records of misdemeanor convictions, without advising BellSouth of the nature and gravity of the offense(s). BellSouth reserves the right to refuse building access to any Adelphia personnel who have been identified to have misdemeanor criminal convictions.

11.1.4 For each Adelphia employee requiring access to a BellSouth Central Office pursuant to this agreement, Adelphia shall furnish BellSouth, prior to an employee gaining such access, a notarized affidavit certifying that the aforementioned background check and security training were completed. The affidavit will contain a statement certifying no felony convictions were found and certifying that the security training was completed by the employee. If the employee's criminal history includes misdemeanor convictions, Adelphia will disclose the nature of the convictions to BellSouth at that time.

11.1.5 At BellSouth's request, Adelphia shall promptly remove from the BellSouth's premises any employee of Adelphia BellSouth does not wish to grant access to its premises pursuant to any investigation conducted by BellSouth.

11.2 Notification to BellSouth. BST reserves the right to interview Adelphia's employees, agents, or contractors. Adelphia and its contractors shall cooperate fully with BellSouth's investigation into allegations of wrongdoing or criminal conduct committed by or involving Adelphia's employees, agents, or contractors. Additionally, BellSouth reserves the right to bill Adelphia for all costs associated with investigations involving its employees, agents, or contractors if it can be reasonably established that Adelphia's employees, agents, or contractors are responsible for the alleged act. BellSouth shall bill Adelphia for BellSouth property which is stolen or damaged where an investigation determines the culpability of

Adelphia's employees, agents, or contractors. Adelphia shall notify BellSouth in writing immediately in the event that the CLEC discovers one of its employees already working on the BellSouth premises is a possible security risk. BellSouth reserves the right to permanently remove from its premises any employee of Adelphia identified as posing a security risk to BellSouth or any other CLEC, or having violated BellSouth policies set forth in the BellSouth CLEC Security Training. Adelphia shall hold BellSouth harmless for any damages resulting from such removal of its personnel from BellSouth premises.

11.3 Use of BellSouth Supplies by Adelphia Employees. Use of any BellSouth supplies by a Adelphia employee, whether or not used routinely to provide telephone service (e.g. plug-in cards,) will be considered theft and will be handled accordingly. Costs associated with such unauthorized use of BellSouth property may be charged to Adelphia as may be all associated investigative costs. At BellSouth's request, Adelphia shall promptly and permanently remove from BellSouth's Central Office any employee of Adelphia found to be in violation of this rule.

11.4 Use of Official Lines by Adelphia Employees. Except for local calls necessary in the performance of their work, Adelphia employees shall not use the telephones on BellSouth Central Office. Charges for unauthorized telephone calls made by a Adelphia's employees may be charged to Adelphia as may be all associated investigative costs. At BellSouth's request, Adelphia shall promptly and permanently remove from BellSouth's premises any employee of Adelphia found to be in violation of this rule.

11.5 Accountability. Full compliance with the Security requirements of this section shall in no way limit the accountability of any CLEC for the improper actions of its employees.

12. DESTRUCTION OF COLLOCATION SPACE

12.1 In the event a Collocation Space is wholly or partially damaged by fire, windstorm, tornado, flood or by similar causes to such an extent as to be rendered wholly unsuitable for Adelphia's permitted use hereunder, then either party may elect within ten (10) days after such damage, to terminate this Attachment, and if either party shall so elect, by giving the other written notice of termination, both parties shall stand released of and from further liability under the terms hereof. If the Collocation Space shall suffer only minor damage and shall not be rendered wholly unsuitable for Adelphia's permitted use, or is damaged and the option to terminate is not exercised by either party, BellSouth covenants and agrees to proceed promptly without expense to Adelphia, except for improvements not the property of BellSouth, to repair the damage. BellSouth shall have a reasonable time within which to rebuild or make any repairs, and such rebuilding and repairing shall be subject to delays caused by storms, shortages of labor and materials, government regulations, strikes, walkouts, and causes beyond the control of BellSouth, which causes shall not be construed as limiting factors, but as exemplary only. Adelphia may, at its own expense, accelerate the rebuild of its collocated space and equipment provided however that a certified vendor is used and the necessary space preparation has been completed. Rebuild of equipment must be performed by a BellSouth Certified Vendor. If Adelphia's acceleration of the project increases the cost of the project, then those additional charges will be incurred by Adelphia. Where allowed and where practical, Adelphia may erect a temporary facility while BellSouth rebuilds or makes repairs. In all cases where the Collocation Space shall be rebuilt or repaired, Adelphia shall be entitled to an equitable abatement of rent and other charges, depending upon the unsuitability of the Collocation Space for Adelphia's permitted use, until such Collocation Space is fully repaired and restored and Adelphia's equipment installed therein (but in no event later than thirty (30)

days after the Collocation Space is fully repaired and restored). Where Adelphia has placed an Adjacent Arrangement pursuant to section 3.4, Adelphia shall have the sole responsibility to repair or replace said Adjacent Arrangement provided herein. Pursuant to this section, BellSouth will restore the associated services to the Adjacent Arrangement.

13. EMINENT DOMAIN

13.1 If the whole of a Collocation Space or Adjacent Arrangement shall be taken by any public authority under the power of eminent domain, then, with respect to such Collocation Space or Adjacent Arrangement, this Attachment shall terminate as of the day possession shall be taken by such public authority and rent and other charges for the Collocation Space or Adjacent Arrangement shall be paid up to that day with proportionate refund by BellSouth of such rent and charges as may have been paid in advance for a period subsequent to the date of the taking. If any part of the Collocation Space or Adjacent Arrangement shall be taken under eminent domain, BellSouth and Adelphia shall each have the right to terminate this Attachment with respect to such Collocation Space or Adjacent Arrangement and declare the same null and void, by written notice of such intention to the other party within ten (10) days after such taking.

14. NONEXCLUSIVITY

12.1 Adelphia understands that this Attachment is not exclusive and that BellSouth may enter into similar agreements with other parties. Assignment of space pursuant to all such agreements shall be determined by space availability and made on a first come, first served basis.

**EXHIBIT A: BELLSOUTH/Adelphia RATES – ALABAMA
PHYSICAL COLLOCATION**

Rates marked with an asterisk (*) are interim and are subject to true-up

| USOC | Rate Element Description | Unit | Recurring Rate (RC) | Non-Recurring Rate (NRC) |
|-------|---|-----------------------|---------------------|--|
| PE1BA | Application Fee | Per request | NA | \$7,124.00 Disconnect Charge \$1.73 |
| PE1CA | Subsequent Application Fee (Note 1) | Per request | NA | \$1,600.00 Minimum |
| | Space Preparation | | | |
| | Firm Order Processing, NRC | | NA | \$1,211.00* |
| | Central Office Modifications, Per sq. ft., per mo. | | \$2.58* | NA |
| | Common Systems Modifications – Cageless, per sq. ft., per mo. | | \$2.96* | NA |
| | Common Systems Modifications – Cages, per cage., per mo. | | \$100.66* | NA |
| PE1BW | Space Enclosure (Note 2) Welded Wire-mesh | Per first 100 sq. ft. | \$136.64 | NA |
| PE1CW | Welded Wire-mesh | Per add'l 50 sq. ft. | \$15.85 | NA |
| PE1PJ | Floor Space | Per sq. ft. | \$3.85 | NA |
| PE1BD | Cable Installation | Per cable | NA | \$2,335.00 |
| PE1PM | Cable Support Structure | Per entrance cable | \$23.23 | NA |
| | Power | | | |
| | Power, per fused amp, per mo. | | \$8.86* | |
| | 120V AC Single Phase Standby, per breaker amp, per mo. | | \$5.62* | |
| | 240V AC Single Phase Standby, per breaker amp, per mo. | | \$11.26* | |
| | 120V AC Three Phase Standby, per breaker amp, per mo. | | \$16.88* | |
| | 277V AC Three Phase Standby, per breaker amp, per mo. | | \$38.98* | |
| PE1P2 | Cross Connects (Note 3) 2-wire | Per cross connect | \$0.28 | First/Add'l \$30.76/\$29.40 |
| PE1P4 | 4-wire | | \$0.56 | \$31.01/\$29.58 |
| PE1P1 | DS-1 | | \$2.14 | \$60.81/\$41.71 |
| PE1P3 | DS-3 | | \$38.63 | \$57.80/\$39.81 |

| ALABAMA (continued) | | | | |
|--|---|--|--|---|
| USOC | Rate Element Description | Unit | Recurring Rate (RC) | Non-Recurring Rate (NRC) |
| PE1F2 PE1F4 | Cross Connects (continued) 2-fiber 4-fiber 2-wire 4-wire DS-1 DS-3 2-fiber 4-fiber | Per cross connect | \$12.10 \$21.75 | First/Add'l \$55.46/\$39.18 \$66.71/\$50.43 Disconnect Charges First/Add'l \$12.75/\$11.38 \$12.82/\$11.39 \$12.85/\$11.50 \$14.93/\$11.76 \$16.83/\$13.27 \$21.86/\$18.31 |
| | Co-Carrier Cross-Connect (Note 4) Fiber Cable Support Structure, per linear ft., per cable, per mo. Copper or Coaxial Cable Support Structure, per liner ft., per cable, per mo. | | \$\$.003* \$.004* | \$540.00* \$540.00* |
| PE1AX PE1AA PE1AR | Security Access System Security System* New Access Card Activation* Administrative change, existing card* Replace lost or stolen card* | Per central office Per card Per card Per card | \$52.00 | \$55.00 \$35.00 \$250.00 |
| PE1SR | Space Availability Report* | Per premises requested | | \$550.00 |
| PE1PE PE1PF PE1PG PE1PH PE1B2 PE1B4 | POT Bay Arrangements <i>Prior to 6/1/99</i> 2-Wire Cross-Connect 4-Wire Cross-Connect DS1 Cross-Connect DS3 Cross-Connect 2-Fiber Cross-Connect 4-Fiber Cross-Connect | Per cross connect | \$0.08 \$0.17 \$0.69 \$4.74 \$32.02 \$40.48 | NA NA NA NA NA NA |

| ALABAMA (continued) | | | | |
|---------------------|-------------------------------------|--|---------------------|--|
| USOC | Rate Element Description | Unit | Recurring Rate (RC) | Non-Recurring Rate (NRC) |
| AEH | Additional Engineering Fee (Note 5) | Per request, First half hour/add'l half hour | | First/Add'l Basic Time \$31.00/\$22.00 Overtime \$37.00/\$26.00 |
| | | | | |
| | Security Escort | Per half hr/add'l half hr | | |
| PE1BT | Basic Time | | NA | \$43.47/\$25.82 |
| PE1OT | Overtime | | NA | \$55.25/\$32.79 |
| PE1PT | Premium Time | | NA | \$67.03/\$39.76 |

Note(s):

N/A refers to rate elements which do not have a negotiated rate.

- (1) **Subsequent Application Fee:** BellSouth requires the submission of an Application Fee for modifications to an existing arrangement. However, when the modifications do not require BellSouth assessment related to expenditure of capital, BellSouth will assess the Subsequent Application Fee in lieu of the Application Fee. Proposed modifications that could result in assessment of a Subsequent Application Fee would cause BellSouth to analyze the following but are not limited to: floor loading changes, changes to HVAC requirements, power requirement changes which may result in a power plant upgrade, environmental or safety requirements, or equipment relocation. Should the Subsequent Application Fee not be included as part of this Attachment, Adelphia will be assessed the full Application Fee for all subsequent activity for completed arrangements.
- (2) **Space Enclosure:** The Space Enclosure Construction Fee is a monthly recurring fee, assessed per enclosure, per location with a one-hundred (100) square foot minimum enclosure. It recovers costs associated with providing an optional equipment arrangement enclosure, which include architectural and engineering fees, materials, and installation costs. The cost for additional square feet is applicable only when ordered with the first 100 square feet and must be requested in fifty (50) square foot increments. Adelphia may, at its option, arrange with a BellSouth Certified Contractor to construct the space enclosure in accordance with BellSouth's guidelines and specifications. In this event, the BellSouth Certified Contractor shall directly bill Adelphia for the space enclosure, and this fee shall not be applicable.
- (3) **Cross Connects:** The charges for cross connects are for orders placed electronically. Cross connect elements may also be ordered manually for which there is an additional charge per element.

| | First / Additional | Disconnect Charges First / Additional |
|--------|--------------------|--|
| 2-wire | \$34.03 / \$32.67 | \$14.48 / \$13.11 |
| 4-wire | \$34.28 / \$32.85 | \$14.55 / \$13.12 |
| DS-1 | \$64.08 / \$44.98 | \$14.58 / \$13.23 |
| DS-3 | \$61.07 / \$43.08 | \$16.66 / \$13.49 |

EXHIBIT A: BELLSOUTH/Adelphia RATES – ALABAMA
PHYSICAL COLLOCATION (continued)

- (4) **Co-Carrier Cross-Connect:** As stated in Section 1.2 of the Collocation Attachment, Adelphia may connect to other CLECs within the designated Premises in addition to, and not in lieu of, interconnection to BellSouth services and facilities. Where BellSouth must construct a cable rack structure to house the co-Carrier cross connection, construction charges will be applied on an individual case basis as described in Section 5.6.1 of the Collocation Attachment. BellSouth shall provide an estimate of these charges in the Application Response. Where an existing cable rack structure is in place and has sufficient capacity to accommodate the co-Carrier cross connection requested, the recurring charges as stated in this Exhibit A shall apply.
- (5) **Additional Engineering Fee:** BellSouth's additional engineering, and other labor costs associated with handling Adelphia-requested modifications to requests in progress or augmentations to existing arrangements shall be recovered as Additional Engineering charges, under provisions in BellSouth's F.C.C. Number 1 Tariff, Sections 13.1 and 13.2.

**EXHIBIT A: BELLSOUTH/Adelphia RATES – FLORIDA
PHYSICAL COLLOCATION**

Rates marked with an asterisk (*) are interim and are subject to true-up

| USOC | Rate Element Description | Unit | Recurring Rate (RC) | Non-Recurring Rate (NRC) |
|-------|---|-----------------------|---------------------|--------------------------|
| PE1BA | Application Fee | Per request | \$15.53 | \$3,248.00 |
| PE1CA | Subsequent Application Fee (Note 1) | Per request | NA | \$1,600.00 Minimum |
| | Space Preparation | | | |
| | Firm Order Processing, NRC | | NA | \$1,211.00* |
| | Central Office Modifications, Per sq. ft., per mo. | | \$2.58* | NA |
| | Common Systems Modifications – Cageless, per sq. ft., per mo. | | \$2.96* | NA |
| | Common Systems Modifications – Cages, per cage., per mo. | | \$100.66* | NA |
| PE1BW | Space Enclosure (Note 2) Wire Cage | Per first 100 sq. ft. | \$41.99 | NA |
| PE1BC | Gypsum Board Cage | Per first 100 sq. ft. | \$84.10 | NA |
| PE1BF | Fire Rated Cage | Per first 100 sq. ft. | \$99.73 | NA |
| PE1CW | Wire Cage | Per add'l 50 sq. ft. | \$4.14 | NA |
| PE1CC | Gypsum Board Cage | Per add'l 50 sq. ft. | \$9.35 | NA |
| PE1CF | Fire Rated Cage | Per add'l 50 sq. ft. | \$11.30 | NA |
| PE1PJ | Floor Space | Per sq. ft. | \$4.25 | NA |
| PE1BD | Cable Installation | Per cable | \$2.77 | \$1,056.00 |
| PE1PM | Cable Support Structure | | \$22.94 | NA |
| | Power | | | |
| | Power, per fused amp, per mo. | | \$8.86 | |
| | 120V AC Single Phase Standby, per breaker amp, per mo. | | \$5.62 | |
| | 240V AC Single Phase Standby, per breaker amp, per mo. | | \$11.26 | |
| | 120V AC Three Phase Standby, per breaker amp, per mo. | | \$16.88 | |
| | 277V AC Three Phase Standby, per breaker amp, per mo. | | \$38.98 | |
| PE1P2 | Cross Connects (Note 3) 2-wire | Per cross connect | \$0.0524 | \$11.57 |
| PE1P4 | 4-wire | | \$0.0524 | \$11.57 |

| FLORIDA (continued) | | | | |
|---------------------|--|--|---------------------|--|
| USOC | Rate Element Description | Unit | Recurring Rate (RC) | Non-Recurring Rate (NRC) |
| | Cross Connects (continued) | Per cross connect | | |
| PE11S | DS-1/DCS | | \$8.085 | \$69.64 |
| PE1P1 | DS-1/DSX | | \$4.110 | \$69.64 |
| PE13S | DS-3/DCS | | \$56.97 | \$528.00 |
| PE13X | DS-3/DSX | | \$10.06 | \$528.00 |
| PE1F2 | Optical Cross Connects | | \$6.46 | \$2,431.00 |
| | | | | |
| | Co-Carrier Cross-Connect (Note 4) | | | |
| | Fiber Cable Support Structure, per linear ft., per cable, per mo. | | \$0.003* | \$540.00* |
| | Copper or Coaxial Cable Support Structure, per liner ft., per cable, per mo. | | \$0.004* | \$540.00* |
| PE1AX | Security Access System Security System* | Per premises | \$52.00 | |
| PE1AA | New Access Card Activation* Administrative change, existing card* | Per request 5 cards Per card | NA | \$85.12 \$35.00 |
| PE1AR | Replace lost or stolen card* | Per card | | \$250.00 |
| | | | | |
| PE1SR | Space Availability Report* | Per premises requested | | \$550.00 |
| | | | | |
| | POT Bay (Note 5) | | NA | NA |
| | | | | |
| AEH | Additional Engineering Fee (Note 6) | Per request, First half hour/add'l half hour | | First/Add'l Basic Time \$31.00/\$22.00 Overtime \$37.00/\$26.00 |
| | | | | |
| PE1BT | Security Escort Basic Time | Per ¼ hour | NA | \$10.89 |
| PE1OT | Overtime | | NA | \$13.64 |
| PE1PT | Premium Time | | NA | \$16.40 |

EXHIBIT A: BELLSOUTH/Adelphia RATES – FLORIDA
PHYSICAL COLLOCATION (continued)

Note(s):

N/A refers to rate elements which do not have a negotiated rate.

(1) **Subsequent Application Fee:** BellSouth requires the submission of an Application Fee for modifications to an existing arrangement. However, when the modifications do not require BellSouth to expend capital, BellSouth will assess the Subsequent Application Fee in lieu of the Application Fee. Proposed modifications that could result in assessment of a Subsequent Application Fee would cause BellSouth to analyze the following but are not limited to: floor loading changes, changes to HVAC requirements, power requirement changes which may result in a power plant upgrade, environmental or safety requirements, or equipment relocation. Should the Subsequent Application Fee not be included as part of this Attachment, Adelphia will be assessed the full Application Fee for all subsequent activity for completed arrangements.

(2) **Space Enclosure Fee:** The Space Enclosure Construction Fee is a monthly recurring fee, assessed per enclosure, per location with a one-hundred (100) square foot minimum enclosure. It recovers costs associated with providing an optional equipment arrangement enclosure, which include architectural and engineering fees, materials, and installation costs. The cost for additional square feet is applicable only when ordered with the first 100 square feet and must be requested in fifty (50) square foot increments. Adelphia may, at its option, arrange with a BellSouth Certified Contractor to construct the space enclosure in accordance with BellSouth’s guidelines and specifications. In this event, the BellSouth Certified Contractor shall directly bill Adelphia for the space enclosure, and this fee shall not be applicable.

(3) **Cross Connects:** Rates shown are the equivalent per cross connect rates based on the Florida PSC Ordered rates as follows:

| <u>Cross Connects</u> | <u>Per Cross Connect</u> | <u>RC</u> | <u>NRC</u> |
|------------------------|--------------------------|-----------|------------|
| 2-wire | Per 100 X-Connects | \$5.24 | \$1,157.00 |
| 4-wire | Per 100 X-Connects | \$5.24 | \$1,157.00 |
| DS-1/DCS | Per 28 X-Connects | \$226.39 | \$1,950.00 |
| DS-1/DSX | Per 28 X-Connects | \$11.51 | \$1,950.00 |
| DS-3/DCS | Per Cross Connect | \$56.97 | \$ 528.00 |
| DS-3/DSX | Per Cross Connect | \$10.06 | \$528.00 |
| Optical Cross Connects | Per Cross Connect | \$6.46 | \$2,431.00 |

(4) **Co-Carrier Cross-Connect.** As stated in Section 5 of the Collocation Attachment, Adelphia may connect to other CLECs within the designated Premises in addition to, and not in lieu of, interconnection to BellSouth services and facilities. Where BellSouth must construct a cable rack structure to house the direct connection, construction charges will be applied on an individual case basis as described in Section 5.6.1 of the Collocation Attachment. BellSouth shall provide an estimate of these charges in the Application Response. Where an existing cable rack structure is in place and has sufficient capacity to accommodate the direct connection requested, the recurring charges as stated in this Exhibit A shall apply.

EXHIBIT A: BELLSOUTH/Adelphia RATES – FLORIDA
PHYSICAL COLLOCATION (continued)

- (5) **POT Bays:** BellSouth's Florida specific rates were established in the Florida Public Service Commission Docket No. 960833. The Commission did not set permanent rates for POT Bays, given the assumption by the Parties to the Proceeding that they will always provide their own POT Bays. It will be necessary for Adelphia to provide its own POT Bays per BellSouth specifications and provide the necessary information from which BellSouth can inventory.
- (6) **Additional Engineering Fee:** BellSouth's additional engineering, and other labor costs associated with handling Adelphia-requested modifications to requests in progress or augmentations to existing arrangements shall be recovered as Additional Engineering charges, under provisions in BellSouth's F.C.C. Number 1 Tariff, Sections 13.1 and 13.2.

**EXHIBIT A: BELLSOUTH/Adelphia RATES – GEORGIA
PHYSICAL COLLOCATION**

Rates marked with an asterisk (*) are interim and subject to true-up

| USOC | Rate Element Description | Unit | Recurring Rate (RC) | Non-Recurring Rate (NRC) |
|-------|---|-----------------------|---------------------|--------------------------------|
| PE1BA | Application Fee | Per request | NA | \$3,850.00 |
| PE1CA | Subsequent Application Fee (Note 1) | Per request | NA | \$1,600.00 Minimum |
| PE1BG | Space Preparation Fee (Note 2) | Per sq. ft. | NA | \$100.00 |
| PE1BW | Space Enclosure (Note 3) Welded Wire-mesh | Per first 100 sq. ft. | \$170.64 | NA |
| PE1CW | Welded Wire-mesh | Per add'l 50 sq. ft. | \$17.33 | NA |
| PE1PJ | Floor Space Zone A | Per sq. ft. | \$7.50 | NA |
| PE1PK | Zone B | Per sq. ft. | \$6.75 | NA |
| PE1BD | Cable Installation | Per cable | NA | \$2,750.00 |
| PE1PM | Cable Support Structure | Per entrance cable | \$13.35 | NA |
| PE1PL | Power -48V DC Power | Per amp | \$5.00 | ICB |
| PE1FB | 120V AC Power single phase* | Per breaker amp | \$5.50 | ICB |
| PE1FD | 240V AC Power single phase* | Per breaker amp | \$11.00 | ICB |
| PE1FE | 120V AC Power three phase* | Per breaker amp | \$16.50 | ICB |
| PE1FG | 277 AC Power three phase* | Per breaker amp | \$38.20 | ICB |
| PE1P2 | Cross Connects 2-wire | Per cross connect | \$0.30 | First/Add'l \$12.60/\$12.60 |
| PE1P4 | 4-wire | | \$0.50 | \$12.60/\$12.60 |
| PE1P1 | DS-1 | | \$8.00 | \$155.00/\$27.00 |
| PE1P3 | DS-3 | | \$72.00 | \$155.00/\$27.00 |
| PE1F2 | 2-fiber | | \$15.64 | \$41.56/\$29.82 |
| PE1F4 | 4-fiber | | \$28.11 | \$50.53/\$38.78 |
| | Co-Carrier Cross-Connect (Note 4) Fiber Cable Support Structure, per linear ft., per cable, per mo. | | \$.003* | \$540.00* |
| | Copper or Coaxial Cable Support Structure, per liner ft., per cable, per mo. | | \$.004* | \$540.00* |

| GEORGIA (continued) | | | | |
|---------------------|--|--|---------------------|--|
| USOC | Rate Element Description | Unit | Recurring Rate (RC) | Non-Recurring Rate (NRC) |
| PE1AX | Security Access System Security System* | Per premises | \$52.00 | |
| PE1AA | New Access Card Activation* Administrative change, existing card* | Per card Per card | | \$55.00 \$35.00 |
| PE1AR | Replace lost or stolen card* | Per card | | \$250.00 |
| PE1SR | Space Availability Report* | Per premises requested | | \$550.00 |
| | POT Bay Arrangements <i>Prior to 6/1/99</i> | Per cross-connect | | |
| PE1PE | 2-Wire Cross-Connect | | \$0.40 | NA |
| PE1PF | 4-Wire Cross-Connect | | \$1.20 | NA |
| PE1PG | DS1 Cross-Connect | | \$1.20 | NA |
| PE1PH | DS3 Cross-Connect | | \$8.00 | NA |
| PE1B2 | 2 Fiber Cross-Connect | | \$38.79 | NA |
| PE1B4 | 4 Fiber Cross-Connect | | \$52.31 | NA |
| AEH | Additional Engineering Fee (Note 5) | Per request, First half hour/add'l half hour | | First/Add'l Basic Time \$31.00/\$22.00 Overtime \$37.00/\$26.00 |
| | Security Escort | Per half hr./Add'l half hr. | | |
| PE1BT | Basic Time | | NA | \$41.00/\$25.00 |
| PE1OT | Overtime | | NA | \$48.00/\$30.00 |
| PE1PT | Premium Time | | NA | \$55.00/\$35.00 |

Note(s)

N/A refers to rate elements which do not have a negotiated rate.

(1) **Subsequent Application Fee:** BellSouth requires the submission of an Application Fee for modifications to an existing arrangement. However, when the modifications do not require BellSouth to expend capital, BellSouth will assess the Subsequent Application Fee in lieu of the Application Fee. Proposed modifications that could result in assessment of a Subsequent Application Fee would cause BellSouth to analyze the following but are not limited to: floor loading changes, changes to HVAC requirements, power requirement changes which may result in a power plant upgrade, environmental or safety requirements, or equipment relocation. Should the Subsequent Application Fee not be included as part of this Attachment, Adelphia will be assessed the full Application Fee for all subsequent activity for completed arrangements.

EXHIBIT A: BELLSOUTH/Adelphia RATES – GEORGIA
PHYSICAL COLLOCATION (continued)

- (2) **Space Preparation Fee:** The Space Preparation Fee is a one-time fee, assessed per arrangement, per location. It recovers a portion of costs associated with the shared physical collocation area within a Premises, which include survey, engineering, design and modification costs for network, building and support systems. This is a set fee of \$100 per square foot as established by the Georgia Public Service Commission Order in Docket No. 7061-U. In the event Adelphia opts for non-enclosed space, the space preparation fee will be assessed based on the total floor space dedicated to Adelphia as prescribed in Section 7 of the Collocation Attachment.
- (3) **Space Enclosure Fee:** The Space Enclosure Construction Fee is a one-time fee, assessed per enclosure, per location with a one-hundred (100) square foot minimum enclosure. It recovers costs associated with providing an optional equipment arrangement enclosure, which include architectural and engineering fees, materials, and installation costs. The cost for additional square feet is applicable only when ordered with the first 100 square feet and must be requested in fifty (50) square foot increments. Adelphia may, at its option, arrange with a BellSouth Certified Contractor to construct the space enclosure in accordance with BellSouth's guidelines and specifications. In this event, the BellSouth Certified Contractor shall directly bill Adelphia for the space enclosure, and this fee shall not be applicable.
- (4) **Co-Carrier Cross-Connect.** As stated in Section 5 of the Collocation Attachment, Adelphia may connect to other CLECs within the designated Premises in addition to, and not in lieu of, interconnection to BellSouth services and facilities. Where BellSouth must construct a cable rack structure to house the co-Carrier cross connection, construction charges will be applied on an individual case basis as described in Section 5.6.1 of the Collocation Attachment. BellSouth shall provide an estimate of these charges in the Application Response. Where an existing cable rack structure is in place and has sufficient capacity to accommodate the co-Carrier cross-connection requested, the recurring charges as stated in this Exhibit A shall apply.
- (5) **Additional Engineering Fee:** BellSouth's additional engineering, and other labor costs associated with handling Adelphia-requested modifications to requests in progress or augmentations to existing arrangements shall be recovered as Additional Engineering charges, under provisions in BellSouth's F.C.C. Number 1 Tariff, Sections 13.1 and 13.2.

**EXHIBIT A: BELLSOUTH/Adelphia RATES – KENTUCKY
PHYSICAL COLLOCATION**

Rates marked with an asterisk (*) are interim and are subject to true-up.

| USOC | Rate Element Description | Unit | Recurring Rate (RC) | Non-Recurring Rate (NRC) |
|-------|---|-----------------------|---------------------|--------------------------------|
| PE1BA | Application Fee | Per request | NA | \$9,926.72 |
| PE1CA | Subsequent Application Fee (Note 1) | Per request | NA | \$1,600.00 Minimum |
| | Space Preparation | | | |
| | Firm Order Processing, NRC | | NA | \$1,211.00* |
| | Central Office Modifications, Per sq. ft., per mo. | | \$2.58* | |
| | Common Systems Modifications – Cageless, per sq. ft., per mo. | | \$2.96* | |
| | Common Systems Modifications – Cages, per cage, per mo. | | \$100.66* | |
| PE1BW | Space Enclosure (Note 2) Welded Wire-mesh | Per first 100 sq. ft. | \$201.02 | NA |
| PE1CW | Welded Wire-mesh | Per add'l 50 sq. ft. | \$20.42 | NA |
| PE1PJ | Floor Space | Per sq. ft. | \$5.00 | NA |
| PE1BD | Cable Installation | Per cable | NA | \$2,327.08 |
| PE1PM | Cable Support Structure | Per entrance cable | \$24.23 | NA |
| | Power | | | |
| | Power, per fused amp, per mo. | | \$8.86* | |
| | 120V AC Single Phase Standby, per breaker amp, per mo. | | \$5.62* | |
| | 240V AC Single Phase Standby, per breaker amp, per mo. | | \$11.26* | |
| | 120V AC Three Phase Standby, per breaker amp, per mo. | | \$16.88* | |
| | 277V AC Three Phase Standby, per breaker amp, per mo. | | \$38.98* | |
| PE1P2 | Cross Connects 2-wire | Per cross connect | \$0.31 | First/Add'l \$54.21/\$51.07 |
| PE1P4 | 4-wire | | \$0.62 | \$54.23/\$50.96 |
| PE1P1 | DS-1 | | \$1.92 | \$99.23/\$69.15 |
| PE1P3 | DS-3 | | \$39.94 | \$97.48/\$66.90 |
| PE1F2 | 2-fiber | | \$15.64 | \$41.56/\$29.82 |
| PE1F4 | 4-fiber | | \$28.11 | \$50.53/\$38.78 |

| KENTUCKY (continued) | | | | |
|----------------------|---|---|----------------------|--|
| USOC | Rate Element Description | Unit | Recurring Rate (RC) | Non-Recurring Rate (NRC) |
| | Co-Carrier Cross-Connect (Note 3) Fiber Cable Support Structure, per linear ft., per cable, per mo. Copper or Coaxial Cable Support Structure, per liner ft., per cable, per mo. | | \$.003* \$.004* | \$540.00* \$540.00* |
| PE1AX | Security Access System Security System* | Per premises | \$52.00 | |
| PE1AA | New Access Card Activation Administrative change, existing card | Per card Per card | | \$55.00 \$35.00 |
| PE1AR | Replace lost or stolen card | Per card | | \$250.00 |
| PE1SR | Space Availability Report | Per premises requested | | \$550.00 |
| PE1PE | POT Bay Arrangements <i>Prior to 6/1/99</i> 2-Wire Cross-Connect | Per cross-connect | \$0.06 | NA |
| PE1PF | 4-Wire Cross-Connect | | \$0.15 | NA |
| PE1PG | DS1 Cross-Connect | | \$0.58 | NA |
| PE1PH | DS3 Cross-Connect | | \$4.51 | NA |
| PE1B2 | 2 Fiber Cross-Connect | | \$38.79 | NA |
| PE1B4 | 4 Fiber Cross-Connect | | \$52.31 | NA |
| PE1BT | Security Escort Basic Time | Per half hr./Add'l half hr. | NA | \$56.09/\$31.99 |
| PE1OT | Overtime | | NA | \$67.75/\$39.00 |
| PE1PT | Premium Time | | NA | \$79.41/\$46.01 |
| AEH | Additional Engineering Fee (Note 4) | Per request, first half hr/add'l half hr. | | First/Add'l Basic Time \$31.00/\$22.00 Overtime \$37.00/\$26.00 |

EXHIBIT A: BELLSOUTH/Adelphia RATES – KENTUCKY
PHYSICAL COLLOCATION (continued)

Note(s):

N/A refers to rate elements which do not have a negotiated rate.

- (1) **Subsequent Application Fee:** BellSouth requires the submission of an Application Fee for modifications to an existing arrangement. However, when the modifications do not require BellSouth to expend capital, BellSouth will assess the Subsequent Application Fee in lieu of the Application Fee. Proposed modifications that could result in assessment of a Subsequent Application Fee would cause BellSouth to analyze the following but are not limited to: floor loading changes, changes to HVAC requirements, power requirement changes which may result in a power plant upgrade, environmental or safety requirements, or equipment relocation. Should the Subsequent Application Fee not be included as part of this Attachment, Adelphia will be assessed the full Application Fee for all subsequent activity for completed arrangements.
- (2) **Space Enclosure Fee:** The Space Enclosure Construction Fee is a one-time fee, assessed per enclosure, per location with a one-hundred (100) square foot minimum enclosure. It recovers costs associated with providing an optional equipment arrangement enclosure, which include architectural and engineering fees, materials, and installation costs. The cost for additional square feet is applicable only when ordered with the first 100 square feet and must be requested in fifty (50) square foot increments. Adelphia may, at its option, arrange with a BellSouth Certified Contractor to construct the space enclosure in accordance with BellSouth's guidelines and specifications. In this event, the BellSouth Certified Contractor shall directly bill Adelphia for the space enclosure, and this fee shall not be applicable.
- (3) **Co-Carrier Cross-Connect.** As stated in Section 5 of the Collocation Attachment, Adelphia may connect to other CLECs within the designated Premises in addition to, and not in lieu of, interconnection to BellSouth services and facilities. Where BellSouth must construct a cable rack structure to house the co-Carrier cross-connection, construction charges will be applied on an individual case basis as described in Section 5.6.1 of the Collocation Attachment. BellSouth shall provide an estimate of these charges in the Application Response. Where an existing cable rack structure is in place and has sufficient capacity to accommodate the co-Carrier cross-connection requested, the recurring charges as stated in this Exhibit A shall apply.
- (4) **Additional Engineering Fee:** BellSouth's additional engineering, and other labor costs associated with handling Adelphia-requested modifications to requests in progress or augmentations to existing arrangements shall be recovered as Additional Engineering charges, under provisions in BellSouth's F.C.C. Number 1 Tariff, Sections 13.1 and 13.2.

**EXHIBIT A: BELLSOUTH/Adelphia RATES – LOUISIANA
PHYSICAL COLLOCATION**

Rates marked with an asterisk (*) are interim and are subject to true-up.

| USOC | Rate Element Description | Unit | Recurring Rate (RC) | Non-Recurring Rate (NRC) |
|-------|---|-----------------------|---------------------|--|
| PE1BA | Application Fee | Per request | NA | \$4,910.00 |
| PE1CA | Subsequent Application Fee (Note 1) | Per request | NA | \$1,600.00 Minimum |
| | Space Preparation | | | |
| | Firm Order Processing, NRC | | NA | \$1,211.00* |
| | Central Office Modifications, Per sq. ft., per mo. | | \$2.58* | NA |
| | Common Systems Modifications – Cageless, per sq. ft., per mo. | | \$2.96* | NA |
| | Common Systems Modifications – Cages, per cage., per mo. | | \$100.66* | NA |
| PE1BW | Space Enclosure (Note 2) Welded Wire-mesh | Per first 100 sq. ft. | \$197.55 | NA |
| PE1CW | Welded Wire-mesh | Per add'l 50 sq. ft. | \$20.07 | NA |
| PE1PJ | Floor Space | Per sq. ft. | \$4.01 | NA |
| PE1BD | Cable Installation | Per cable | NA | \$1,706.00 Disconnect charge \$36.00 |
| PE1PM | Cable Support Structure | Per entrance cable | \$24.05 | NA |
| | Power | | | |
| | Power, per fused amp, per mo. | | \$8.86* | |
| | 120V AC Single Phase Standby, per breaker amp, per mo. | | \$5.62* | |
| | 240V AC Single Phase Standby, per breaker amp, per mo. | | \$11.26* | |
| | 120V AC Three Phase Standby, per breaker amp, per mo. | | \$16.88* | |
| | 277V AC Three Phase Standby, per breaker amp, per mo. | | \$38.98* | |
| PE1P2 | Cross Connects (Note 3) 2-wire | Per cross connect | \$0.26 | First/Add'l \$23.04/\$22.11 |
| PE1P4 | 4-wire | | \$0.52 | \$23.23/\$22.24 |
| PE1P1 | DS-1 | | \$2.03 | \$43.61/\$30.60 |
| PE1P3 | DS-3 | | \$36.27 | \$41.46/\$29.20 |

| LOUISIANA (continued) | | | | |
|--|---|--------------------------------------|--|---|
| USOC | Rate Element Description | Unit | Recurring Rate (RC) | Non-Recurring Rate (NRC) |
| PE1F2 PE1F4 | Cross Connects (continued) 2-fiber 4-fiber | Per cross connect | \$19.13 \$34.38 | First/Add'l \$41.07/\$29.63 \$49.81/\$38.37 |
| | 2-wire 4-wire DS-1 DS-3 2-fiber 4-fiber | | | Disconnect Charges First/Add'l \$9.48/\$8.54 \$9.53/\$8.55 \$9.56/\$8.63 \$11.06/\$8.86 \$12.84/\$10.29 \$16.75/\$14.20 |
| | Co-Carrier Cross-Connect (Note 4) Fiber Cable Support Structure, per linear ft., per cable, per mo. Copper or Coaxial Cable Support Structure, per liner ft., per cable, per mo. | | \$.003* \$.004* | \$540.00* \$540.00* |
| PE1AX PE1AA PE1AR | Security Access System Security System* New Access Card Activation* Administrative change, existing card* Replace lost or stolen card | Per premises Per card Per card | \$52.00 | \$55.00 \$35.00 \$250.00 |
| PE1SR | Space Availability Report* | Per premises requested | | \$550.00 |
| PE1PE PE1PF PE1PG PE1PH PE1B2 PE1B4 | POT Bay Arrangements <i>Prior to 6/1/99</i> 2-Wire Cross-Connect 4-Wire Cross-Connect DS1 Cross-Connect DS3 Cross-Connect 2 Fiber Cross-Connect 4 Fiber Cross-Connect | Per cross-connect | \$0.0776 \$0.1552 \$0.6406 \$4.75 \$47.44 \$63.97 | NA NA NA NA NA NA |

| LOUISIANA (continued) | | | | |
|-----------------------|--|---|---------------------|--|
| USOC | Rate Element Description | Unit | Recurring Rate (RC) | Non-Recurring Rate (NRC) |
| | Security Escort | Per half hr./Add'l half hr. | | |
| PE1BT | Basic Time | | NA | \$32.35/\$19.95 |
| PE1OT | Overtime | | NA | \$40.50/\$25.00 |
| PE1PT | Premium Time | | NA | \$48.66/\$30.05 |
| | | | | |
| AEH | Additional Engineering Fee (Note 5) | Per request, first half hr/add'l half hr. | | First/Add'l Basic Time \$31.00/\$22.00 Overtime \$37.00/\$26.00 |

Note(s):

N/A refers to rate elements which do not have a negotiated rate.

- (1) **Subsequent Application Fee:** BellSouth requires the submission of an Application Fee for modifications to an existing arrangement. However, when the modifications do not require BellSouth to expend capital, BellSouth will assess the Subsequent Application Fee in lieu of the Application Fee. Proposed modifications that could result in assessment of a Subsequent Application Fee would cause BellSouth to analyze the following but are not limited to: floor loading changes, changes to HVAC requirements, power requirement changes which may result in a power plant upgrade, environmental or safety requirements, or equipment relocation. Should the Subsequent Application Fee not be included as part of this Attachment, Adelphia will be assessed the full Application Fee for all subsequent activity for completed arrangements.
- (2) **Space Enclosure Fee:** The Space Enclosure Construction Fee is a monthly recurring fee, assessed per enclosure, per location with a one-hundred (100) square foot minimum enclosure. It recovers costs associated with providing an optional equipment arrangement enclosure, which include architectural and engineering fees, materials, and installation costs. The cost for additional square feet is applicable only when ordered with the first 100 square feet and must be requested in fifty (50) square foot increments. Adelphia may, at its option, arrange with a BellSouth Certified Contractor to construct the space enclosure in accordance with BellSouth's guidelines and specifications. In this event, the BellSouth Certified Contractor shall directly bill Adelphia for the space enclosure, and this fee shall not be applicable.

EXHIBIT A: BELLSOUTH/Adelphia RATES – LOUISIANA
PHYSICAL COLLOCATION (continued)

- (3) **Cross Connects:** The charges for cross connects are for orders placed electronically. Cross connect elements may also be ordered manually for which there is an additional charge per element.

| | First / Additional | Disconnect Charges First / Additional |
|--------|--------------------|--|
| 2-wire | \$24.92/\$23.99 | \$10.56/\$9.62 |
| 4-wire | \$25.11/\$24.12 | \$10.61/\$9.63 |
| DS-1 | \$45.49/\$32.48 | \$10.64/\$9.71 |
| DS-3 | \$43.34/\$31.08 | \$12.14/\$9.94 |

- (4) **Co-Carrier Cross-Connect.** As stated in Section 5 of the Collocation Attachment, Adelphia may connect to other CLECs within the designated Premises in addition to, and not in lieu of, interconnection to BellSouth services and facilities. Where BellSouth must construct a cable rack structure to house the co-Carrier cross-connection, construction charges will be applied on an individual case basis as described in Section 5.6.1 of the Collocation Attachment. BellSouth shall provide an estimate of these charges in the Application Response. Where an existing cable rack structure is in place and has sufficient capacity to accommodate the co-Carrier cross-connection requested, the recurring charges as stated in this Exhibit A shall apply.
- (5) **Additional Engineering Fee:** BellSouth's additional engineering, and other labor costs associated with handling Adelphia-requested modifications to requests in progress or augmentations to existing arrangements shall be recovered as Additional Engineering charges, under provisions in BellSouth's F.C.C. Number 1 Tariff, Sections 13.1 and 13.2.

**(6) EXHIBIT A: BELLSOUTH/Adelphia RATES – MISSISSIPPI
PHYSICAL COLLOCATION**

Rates marked with an asterisk (*) are interim and are subject to true-up.

| USOC | Rate Element Description | Unit | Recurring Rate (RC) | Non-Recurring Rate (NRC) |
|----------------|--|---|--|---|
| PE1BA | Application Fee | Per request | NA | \$6,993.00 Disconnect Charge \$1.70 |
| PE1CA | Subsequent Application Fee (Note 1) | Per request | NA | \$1,600.00 Minimum |
| | Space Preparation Firm Order Processing, NRC Central Office Modifications, Per sq. ft., per mo. | | NA \$2.58* | \$1,211.00* NA |
| | Common Systems Modifications – Cageless, per sq. ft., per mo. | | \$2.96* | NA |
| | Common Systems Modifications – Cages, per cage, per mo. | | \$100.66* | NA |
| PE1BW PE1CW | Space Enclosure (Note 2) Welded Wire-mesh | Per first 100 sq. ft. Per add'l 50 sq. ft. | \$205.08 \$20.83 | NA NA |
| PE1PJ | Floor Space | Per sq. ft. | \$3.45 | |
| PE1BD | Cable Installation | Per cable | NA | \$2,419.00 Disconnection charge \$53.24 |
| PE1PM | Cable Support Structure | Per entrance cable | \$22.90 | NA |
| | Power Power, per fused amp, per mo. 120V AC Single Phase Standby, per breaker amp, per mo. 240V AC Single Phase Standby, per breaker amp, per mo. 120V AC Three Phase Standby, per breaker amp, per mo. 277V AC Three Phase Standby, per breaker amp, per mo. | | \$8.86* \$5.62* \$11.26* \$16.88* \$38.98* | |
| PE1P2 PE1P4 | Cross Connects (Note 3) 2-wire 4-wire | Per cross connect | \$.3996 \$.7992 | First/Add'l \$30.93/\$29.59 \$31.17/\$29.77 |

| MISSISSIPPI (continued) | | | | |
|-------------------------|--|------------------------|---------------------|--------------------------|
| USOC | Rate Element Description | Unit | Recurring Rate (RC) | Non-Recurring Rate (NRC) |
| | Cross Connects (continued) | Per cross connect | | First/Add'l |
| PE1P1 | DS-1 | | \$2.90 | \$60.42/\$41.68 |
| PE1P3 | DS-3 | | \$53.31 | \$57.45/\$39.81 |
| PE1F2 | 2-fiber | | \$15.64 | \$41.56/\$29.82 |
| PE1F4 | 4-fiber | | \$28.11 | \$50.53/\$38.78 |
| | | | | Disconnect Charges |
| | | | | First/Add'l |
| | 2-wire | | | \$12.76/\$11.43 |
| | 4-wire | | | \$12.83/\$11.43 |
| | DS-1 | | | \$12.87/\$11.54 |
| | DS-3 | | | \$14.92/\$11.80 |
| | 2-fiber | | | \$12.96/\$10.34 |
| | 4-fiber | | | \$16.97/\$14.35 |
| | Co-Carrier Cross-Connect (Note 4) | | | |
| | Fiber Cable Support Structure, per linear ft., per cable, per mo. | | \$.003* | \$540.00* |
| | Copper or Coaxial Cable Support Structure, per liner ft., per cable, per mo. | | \$.004* | \$540.00* |
| PE1AX | Security Access System Security System* | Per premises | \$52.00 | |
| PE1AA | New Access Card Activation* Administrative change, existing card* | Per card Per card | | \$55.00 \$35.00 |
| PE1AR | Replace lost or stolen card | Per card | | \$250.00 |
| PE1SR | Space Availability Report* | Per premises requested | | \$550.00 |
| | POT Bay Arrangements <i>Prior to 6/1/99</i> | Per cross-connect | | |
| PE1PE | 2-Wire Cross-Connect | | \$0.1195 | NA |
| PE1PF | 4-Wire Cross-Connect | | \$0.2389 | NA |
| PE1PG | DS1 Cross-Connect | | \$0.9862 | NA |
| PE1PH | DS3 Cross-Connect | | \$5.81 | NA |
| PE1B2 | 2 Fiber Cross-Connect | | \$38.79 | NA |
| PE1B4 | 4 Fiber Cross-Connect | | \$52.31 | NA |

| MISSISSIPPI (continued) | | | | |
|-------------------------|--|---|---------------------|--|
| USOC | Rate Element Description | Unit | Recurring Rate (RC) | Non-Recurring Rate (NRC) |
| | Security Escort | Per half hr./Add'l half hr. | | |
| PE1BT | Basic Time | | NA | \$42.87/\$25.54 |
| PE1OT | Overtime | | NA | \$54.43/\$32.41 |
| PE1PT | Premium Time | | NA | \$65.99/\$39.28 |
| | | | | |
| AEH | Additional Engineering Fee (Note 5) | Per request, first half hr/add'l half hr. | | First/Add'l Basic Time \$31.00/\$22.00 Overtime \$37.00/\$26.00 |

Note(s):

N/A refers to rate elements which do not have a negotiated rate.

- (1) **Subsequent Application Fee:** BellSouth requires the submission of an Application Fee for modifications to an existing arrangement. However, when the modifications do not require BellSouth to expend capital, BellSouth will assess the Subsequent Application Fee in lieu of the Application Fee. Proposed modifications that could result in assessment of a Subsequent Application Fee would cause BellSouth to analyze the following but are not limited to: floor loading changes, changes to HVAC requirements, power requirement changes which may result in a power plant upgrade, environmental or safety requirements, or equipment relocation. Should the Subsequent Application Fee not be included as part of this Attachment, Adelphia will be assessed the full Application Fee for all subsequent activity for completed arrangements.
- (2) **Space Enclosure Fee:** The Space Enclosure Construction Fee is a monthly recurring fee, assessed per enclosure, per location with a one-hundred (100) square foot minimum enclosure. It recovers costs associated with providing an optional equipment arrangement enclosure, which include architectural and engineering fees, materials, and installation costs. The cost for additional square feet is applicable only when ordered with the first 100 square feet and must be requested in fifty (50) square foot increments. Adelphia may, at its option, arrange with a BellSouth Certified Contractor to construct the space enclosure in accordance with BellSouth's guidelines and specifications. In this event, the BellSouth Certified Contractor shall directly bill Adelphia for the space enclosure, and this fee shall not be applicable.

EXHIBIT A: BELLSOUTH/Adelphia RATES – MISSISSIPPI
PHYSICAL COLLOCATION (continued)

- (3) **Cross Connects:** The charges for cross connects are for orders placed electronically. Cross connect elements may also be ordered manually for which there is an additional charge per element.

| | First / Additional | Disconnect Charges First / Additional |
|--------|--------------------|--|
| 2-wire | \$33.58 / \$32.24 | \$14.27 / \$12.94 |
| 4-wire | \$33.82 / \$32.42 | \$14.34 / \$12.94 |
| DS-1 | \$63.07 / \$44.33 | \$14.38 / \$13.05 |
| DS-3 | \$60.10 / \$42.46 | \$16.43 / \$13.31 |

- (4) **Co-Carrier Cross-Connect.** As stated in Section 5 of the Collocation Attachment, Adelphia may connect to other CLECs within the designated Premises in addition to, and not in lieu of, interconnection to BellSouth services and facilities. Where BellSouth must construct a cable rack structure to house the co-Carrier cross-connection, construction charges will be applied on an individual case basis as described in Section 5.6.1 of the Collocation Attachment. BellSouth shall provide an estimate of these charges in the Application Response. Where an existing cable rack structure is in place and has sufficient capacity to accommodate the co-Carrier cross-connection requested, the recurring charges as stated in this Exhibit A shall apply.
- (5) **Additional Engineering Fee:** BellSouth's additional engineering, and other labor costs associated with handling Adelphia-requested modifications to requests in progress or augmentations for existing arrangements shall be recovered as Additional Engineering charges, under provisions in BellSouth's F.C.C. Number 1 Tariff, Sections 13.1 and 13.2.

**EXHIBIT A: BELLSOUTH/Adelphia RATES – NORTH CAROLINA
PHYSICAL COLLOCATION**

Rates marked with an asterisk (*) are interim and are subject to true-up.

| USOC | Rate Element Description | Unit | Recurring Rate (RC) | Non-Recurring Rate (NRC) |
|-------|--|-------------------------|---------------------|--------------------------------|
| PE1BA | Application Fee | Per request | NA | \$3,850.00 |
| PE1CA | Subsequent Application Fee (Note 1) | Per request | NA | \$1,600.00 Minimum |
| | Space Preparation Fee | | | |
| | Central Office Modification | Per sq. ft. | \$1.57 | |
| | Common Systems Modification – Cageless | Per sq. ft. | \$3.26 | |
| | Common Systems Modification – Caged | Per cage | \$110.79 | |
| | Power | Per nominal –48v DC Amp | \$5.76 | |
| PE1BW | Space Enclosure (Note 2) Welded Wire-mesh | Per first 100 sq. ft. | \$102.76 | NA |
| PE1CW | Welded Wire-mesh | Per add'l 50 sq. ft. | \$10.44 | NA |
| PE1PJ | Floor Space | Per sq. ft. | \$3.45 | NA |
| PE1BD | Cable Installation | Per cable | NA | \$2,305.00 |
| PE1PM | Cable Support Structure | Per entrance cable | \$21.33 | NA |
| | Power | | | |
| | Power, per fused amp, per mo. 120V AC Single Phase Standby, per breaker amp, per mo. | | \$8.86* | |
| | 240V AC Single Phase Standby, per breaker amp, per mo. | | \$5.62* | |
| | 120V AC Three Phase Standby, per breaker amp, per mo. | | \$11.26* | |
| | 277V AC Three Phase Standby, | | \$16.88* | |
| PE1P2 | Cross Connects (Note 3) 2-wire | Per cross connect | \$0.32 | First/Add'l \$41.78/\$39.23 |
| PE1P4 | 4-wire | | \$0.64 | \$41.91/\$39.25 |
| PE1P1 | DS-1 | | \$2.34 | \$71.02/\$51.08 |
| PE1P3 | DS-3 | | \$42.84 | \$69.84/\$49.43 |
| PE1F2 | 2-fiber | | \$15.99 | \$67.34/\$48.55 |
| PE1F4 | 4-fiber | | \$28.74 | \$82.35/\$63.56 |

| NORTH CAROLINA (continued) | | | | |
|----------------------------|---|---|---------------------|--|
| USOC | Rate Element Description | Unit | Recurring Rate (RC) | Non-Recurring Rate (NRC) |
| | Co-Carrier Cross-Connect (Note 4) Fiber Cable Support Structure, per linear ft., per cable, per mo. Copper or Coaxial Cable Support Structure, per liner ft., per cable, per mo. | | \$.003* | \$540.00* |
| | | | \$.004* | \$540.00* |
| PE1AX | Security Access System Security System* | Per premises | \$52.00 | |
| PE1AA | New Access Card Activation* | Per card | | \$55.00 |
| | Administrative change, existing card* | Per card | | \$35.00 |
| PE1AR | Replace lost or stolen card | Per card | | \$250.00 |
| PE1SR | Space Availability Report* | Per premises requested | | \$550.00 |
| | POT Bay Arrangements <i>Prior to 6/1/99</i> | Per cross-connect | | |
| PE1PE | 2-Wire Cross-Connect | | \$0.10 | NA |
| PE1PF | 4-Wire Cross-Connect | | \$0.19 | NA |
| PE1PG | DS1 Cross-Connect | | \$0.79 | NA |
| PE1PH | DS3 Cross-Connect | | \$4.85 | NA |
| PE1B2 | 2 Fiber Cross-Connect | | \$39.67 | NA |
| PE1B4 | 4 Fiber Cross-Connect | | \$53.49 | NA |
| | Security Escort | Per half hr./Add'l half hr. | | |
| PE1BT | Basic Time | | NA | \$42.92/\$25.56 |
| PE1OT | Overtime | | NA | \$54.51/\$32.44 |
| PE1PT | Premium Time | | NA | \$66.10/\$39.32 |
| AEH | Additional Engineering Fee (Note 5) | Per request, first half hr/add'l half hr. | | First/Add'l Basic Time \$31.00/\$22.00 Overtime \$37.00/\$26.00 |

EXHIBIT A: BELLSOUTH/Adelphia RATES – NORTH CAROLINA
PHYSICAL COLLOCATION (continued)

Note(s):

N/A refers to rate elements which do not have a negotiated rate.

- (1) **Subsequent Application Fee:** BellSouth requires the submission of an Application Fee for modifications to an existing arrangement. However, when the modifications do not require BellSouth to expend capital, BellSouth will assess the Subsequent Application Fee in lieu of the Application Fee. Proposed modifications that could result in assessment of a Subsequent Application Fee would cause BellSouth to analyze the following but are not limited to: floor loading changes, changes to HVAC requirements, power requirement changes which may result in a power plant upgrade, environmental or safety requirements, or equipment relocation. Should the Subsequent Application Fee not be included as part of this Attachment, Adelphia will be assessed the full Application Fee for all subsequent activity for completed arrangements.
- (2) **Space Enclosure Fee:** The Space Enclosure Construction Fee is a monthly recurring fee, assessed per enclosure, per location with a one-hundred (100) square foot minimum enclosure. It recovers costs associated with providing an optional equipment arrangement enclosure, which include architectural and engineering fees, materials, and installation costs. The cost for additional square feet is applicable only when ordered with the first 100 square feet and must be requested in fifty (50) square foot increments. Adelphia may, at its option, arrange with a BellSouth Certified Contractor to construct the space enclosure in accordance with BellSouth's guidelines and specifications. In this event, the BellSouth Certified Contractor shall directly bill Adelphia for the space enclosure, and this fee shall not be applicable.
- (3) **Cross Connect:** The charges for cross connects are for orders placed electronically. Cross connect elements may also be ordered manually for which there is an additional charge per element.

| | <u>First/Additional</u> |
|--------|-------------------------|
| 2-wire | \$46.53/\$43.98 |
| 4-wire | \$46.64/\$43.98 |
| DS-1 | \$75.72/\$55.78 |
| DS-3 | \$74.54/\$54.13 |

- (4) **Co-Carrier Cross-Connect.** As stated in Section 5 of the Collocation Attachment, Adelphia may connect to other CLECs within the designated Premises in addition to, and not in lieu of, interconnection to BellSouth services and facilities. Where BellSouth must construct a cable rack structure to house the co-Carrier cross-connection, construction charges will be applied on an individual case basis as described in Section 5.6.1 of the Collocation Attachment. BellSouth shall provide an estimate of these charges in the Application Response. Where an existing cable rack structure is in place and has sufficient capacity to accommodate the co-Carrier cross-connection requested, the recurring charges as stated in this Exhibit A shall apply.

**EXHIBIT A: BELLSOUTH/Adelphia RATES – NORTH CAROLINA
PHYSICAL COLLOCATION (continued)**

- (5) **Additional Engineering Fee:** BellSouth's additional engineering, and other labor costs associated with handling Adelphia-requested modifications to requests in progress or augmentations for existing arrangements shall be recovered as Additional Engineering charges, under provisions in BellSouth's F.C.C. Number 1 Tariff, Sections 13.1 and 13.2.

**EXHIBIT A: BELLSOUTH/Adelphia RATES – SOUTH CAROLINA
PHYSICAL COLLOCATION**

Rates marked with an asterisk (*) are interim and are subject to true-up.

| USOC | Rate Element Description | Unit | Recurring Rate (RC) | Non-Recurring Rate (NRC) |
|-------|---|-----------------------|---------------------|--------------------------------|
| PE1BA | Application Fee | Per request | NA | \$4,850.00 |
| PE1CA | Subsequent Application Fee (Note 1) | Per request | NA | \$1,600.00 Minimum |
| | Space Preparation Firm Order Processing, NRC | | NA | \$1,211.00* |
| | Central Office Modifications, Per sq. ft., per mo. | | \$2.58* | NA |
| | Common Systems Modifications – Cageless, per sq. ft., per mo. | | \$2.96* | NA |
| | Common Systems Modifications – Cages, per cage., per mo. | | \$100.66* | NA |
| PE1BW | Space Enclosure (Note 2) Welded Wire-mesh | Per first 100 sq. ft. | \$224.60 | NA |
| PE1CW | Welded Wire-mesh | Per add'l 50 sq. ft. | \$22.81 | NA |
| PE1PJ | Floor Space | Per sq. ft. | \$3.90 | NA |
| PE1BD | Cable Installation | Per cable | NA | \$2,217.00 |
| PE1PM | Cable Support Structure | Per entrance cable | \$24.55 | NA |
| | Power | | | |
| | Power, per fused amp, per mo. | | \$8.86* | |
| | 120V AC Single Phase Standby, per breaker amp, per mo. | | \$5.62* | |
| | 240V AC Single Phase Standby, per breaker amp, per mo. | | \$11.26* | |
| | 120V AC Three Phase Standby, per breaker amp, per mo. | | \$16.88* | |
| | 277V AC Three Phase Standby, per breaker amp, per mo. | | \$38.98* | |
| PE1P2 | Cross Connects (Note 3) 2-wire | Per cross connect | \$.3648 | First/Add'l \$41.50/\$38.94 |
| PE1P4 | 4-wire | | \$.7297 | \$41.56/\$38.90 |
| PE1P1 | DS-1 | | \$2.70 | \$70.79/\$50.78 |
| PE1P3 | DS-3 | | \$49.24 | \$69.60/\$49.14 |
| PE1F2 | 2-fiber | | \$15.06 | \$69.28/\$48.89 |
| PE1F4 | 4-fiber | | \$27.08 | \$84.07/\$63.68 |

| SOUTH CAROLINA (continued) | | | | |
|-----------------------------------|---|---|----------------------------|--|
| USOC | Rate Element Description | Unit | Recurring Rate (RC) | Non-Recurring Rate (NRC) |
| | Co-Carrier Cross-Connect (Note 4) Fiber Cable Support Structure, per linear ft., per cable, per mo. Copper or Coaxial Cable Support Structure, per liner ft., per cable, per mo. | | \$.003* \$.004* | \$540.00* \$540.00* |
| PE1AX | Security Access System Security System* | Per premises | \$52.00 | |
| PE1AA | New Access Card Activation* Administrative change, existing card* | Per card Per card | | \$55.00 \$35.00 |
| PE1AR | Replace lost or stolen card | Per card | | \$250.00 |
| PE1SR | Space Availability Report* | Per premises requested | | \$550.00 |
| | POT Bay Arrangements <i>Prior to 6/1/99</i> | Per cross-connect | | |
| PE1PE | 2-Wire Cross-Connect | | \$0.1091 | NA |
| PE1PF | 4-Wire Cross-Connect | | \$0.2181 | NA |
| PE1PG | DS1 Cross-Connect | | \$0.9004 | NA |
| PE1PH | DS3 Cross-Connect | | \$5.64 | NA |
| PE1B2 | 2 Fiber Cross-Connect | | \$37.36 | NA |
| PE1B4 | 4 Fiber Cross-Connect | | \$50.38 | NA |
| | Security Escort | Per half hr./Add'l half hr. | | |
| PE1BT | Basic Time | | NA | \$43.00/\$25.57 |
| PE1OT | Overtime | | NA | \$54.62/\$32.46 |
| PE1PT | Premium Time | | NA | \$66.24/\$39.35 |
| AEH | Additional Engineering Fee (Note 5) | Per request, first half hr/add'l half hr. | | First/Add'l Basic Time \$31.00/\$22.00 Overtime \$37.00/\$26.00 |

EXHIBIT A: BELLSOUTH/Adelphia RATES – SOUTH CAROLINA
PHYSICAL COLLOCATION (continued)

Note(s):

N/A refers to rate elements which do not have a negotiated rate.

- (1) **Subsequent Application Fee:** BellSouth requires the submission of an Application Fee for modifications to an existing arrangement. However, when the modifications do not require BellSouth to expend capital, BellSouth will assess the Subsequent Application Fee in lieu of the Application Fee. Proposed modifications that could result in assessment of a Subsequent Application Fee would cause BellSouth to analyze the following but are not limited to: floor loading changes, changes to HVAC requirements, power requirement changes which may result in a power plant upgrade, environmental or safety requirements, or equipment relocation. Should the Subsequent Application Fee not be included as part of this Attachment, Adelphia will be assessed the full Application Fee for all subsequent activity for completed arrangements.
- (2) **Space Enclosure Fee:** The Space Enclosure Construction Fee is a monthly recurring fee, assessed per enclosure, per location with a one-hundred (100) square foot minimum enclosure. It recovers costs associated with providing an optional equipment arrangement enclosure, which include architectural and engineering fees, materials, and installation costs. The cost for additional square feet is applicable only when ordered with the first 100 square feet and must be requested in fifty (50) square foot increments. Adelphia may, at its option, arrange with a BellSouth Certified Contractor to construct the space enclosure in accordance with BellSouth's guidelines and specifications. In this event, the BellSouth Certified Contractor shall directly bill Adelphia for the space enclosure, and this fee shall not be applicable.
- (3) **Cross Connects:** The charges for cross connects are for orders placed electronically. Cross connect elements may also be ordered manually for which there is an additional charge per element.

| | <u>First / Additional</u> |
|--------|---------------------------|
| 2-wire | \$46.66 / \$44.10 |
| 4-wire | \$46.68 / \$44.02 |
| DS-1 | \$75.88 / \$55.87 |
| DS-3 | \$74.69 / \$54.23 |

EXHIBIT A: BELLSOUTH/Adelphia RATES – SOUTH CAROLINA
PHYSICAL COLLOCATION (continued)

- (4) **Co-Carrier Cross-Connect.** As stated in Section 5 of the Collocation Attachment, Adelphia may connect to other CLECs within the designated Premises in addition to, and not in lieu of, interconnection to BellSouth services and facilities. Where BellSouth must construct a cable rack structure to house the co-Carrier cross-connection, construction charges will be applied on an individual case basis as described in Section 5.6.1 of the Collocation Attachment. BellSouth shall provide an estimate of these charges in the Application Response. Where an existing cable rack structure is in place and has sufficient capacity to accommodate the co-Carrier cross-connection requested, the recurring charges as stated in this Exhibit A shall apply.
- (5) **Additional Engineering Fee:** BellSouth's additional engineering, and other labor costs associated with handling Adelphia-requested modifications to requests in progress or augmentations to existing arrangements shall be recovered as Additional Engineering charges, under provisions in BellSouth's F.C.C. Number 1 Tariff, Sections 13.1 and 13.2.

**EXHIBIT A: BELLSOUTH/Adelphia RATES – TENNESSEE
PHYSICAL COLLOCATION**

*** Rates are interim and are subject to true-up.**

| USOC | Rate Element Description | Unit | Recurring Rate (RC) | Non-Recurring Rate (NRC) |
|-------|---|-----------------------|---------------------|--------------------------------|
| PE1BA | Application Fee | Per request | NA | \$3,850.00 |
| PE1CA | Subsequent Application Fee (Note 1) | Per request | NA | \$1,600.00 Minimum |
| | Space Preparation Firm Order Processing, NRC | | NA | \$1,211.00* |
| | Central Office Modifications, Per sq. ft., per mo. | | \$2.58* | NA |
| | Common Systems Modifications – Cageless, per sq. ft., per mo. | | \$2.96* | NA |
| | Common Systems Modifications – Cages, per cage., per mo. | | \$100.66* | NA |
| PE1BW | Space Enclosure (Note 2) Welded Wire-mesh | Per first 100 sq. ft. | \$190.79 | NA |
| PE1CW | Welded Wire-mesh | Per add'l 50 sq. ft. | \$19.38 | NA |
| PE1PJ | Floor Space | Per sq. ft. | \$7.50 | NA |
| PE1BD | Cable Installation | Per cable | NA | \$2,750.00 |
| PE1PM | Cable Support Structure | Per entrance cable | \$13.35 | NA |
| | Power | | | |
| | Power, per fused amp, per mo. | | \$8.86* | |
| | 120V AC Single Phase Standby, per breaker amp, per mo. | | \$5.62* | |
| | 240V AC Single Phase Standby, per breaker amp, per mo. | | \$11.26* | |
| | 120V AC Three Phase Standby, per breaker amp, per mo. | | \$16.88* | |
| | 277V AC Three Phase Standby, per breaker amp, per mo. | | \$38.98* | |
| PE1P2 | Cross Connects 2-wire | Per cross connect | \$0.30 | First/Add'l \$19.20/\$19.20 |
| PE1P4 | 4-wire | | \$0.50 | \$19.20/\$19.20 |
| PE1P1 | DS-1 | | \$8.00 | \$155.00/\$27.00 |
| PE1P3 | DS-3 | | \$72.00 | \$155.00/\$27.00 |
| PE1F2 | 2-fiber | | \$15.64 | \$41.56/\$29.82 |
| PE1F4 | 4-fiber | | \$28.11 | \$50.53/\$38.78 |

| TENNESSEE (continued) | | | | |
|-----------------------|---|---|---------------------|--|
| USOC | Rate Element Description | Unit | Recurring Rate (RC) | Non-Recurring Rate (NRC) |
| | Co-Carrier Cross-Connect (Note 3) Fiber Cable Support Structure, per linear ft., per cable, per mo. Copper or Coaxial Cable Support Structure, per liner ft., per cable, per mo. | | \$.003* | \$540.00* |
| | | | \$.004* | \$540.00* |
| PE1AX | Security Access System Security System | Per premises | \$52.00 | |
| PE1AA | New Access Card Activation | Per card | | \$55.00 |
| | Administrative change, existing card | Per card | | \$35.00 |
| PE1AR | Replace lost or stolen card | Per card | | \$250.00 |
| PE1SR | Space Availability Report* | Per premises requested | | \$550.00 |
| PE1PE | POT Bay Arrangements <i>Prior to 6/1/99</i> 2-Wire Cross-Connect | Per cross-connect | \$0.40 | NA |
| PE1PF | 4-Wire Cross-Connect | | \$1.20 | NA |
| PE1PG | DS1 Cross-Connect | | \$1.20 | NA |
| PE1PH | DS3 Cross-Connect | | \$8.00 | NA |
| PE1B2 | 2 Fiber Cross-Connect | | \$38.79 | NA |
| PE1B4 | 4 Fiber Cross-Connect | | \$52.31 | NA |
| PE1BT | Security Escort Basic Time | Per half hr./Add'l half hr. | NA | \$41.00/\$25.00 |
| PE1OT | Overtime | | NA | \$48.00/\$30.00 |
| PE1PT | Premium Time | | NA | \$55.00/\$35.00 |
| AEH | Additional Engineering Fee (Note 4) | Per request, first half hr/add'l half hr. | | First/Add'l Basic Time \$31.00/\$22.00 Overtime \$37.00/\$26.00 |

EXHIBIT A: BELLSOUTH/Adelphia RATES – TENNESSEE
PHYSICAL COLLOCATION (continued)

Note(s):

N/A refers to rate elements which do not have a negotiated rate.

- (1) **Subsequent Application Fee:** BellSouth requires the submission of an Application Fee for modifications to an existing arrangement. However, when the modifications do not require BellSouth to expend capital, BellSouth will assess the Subsequent Application Fee in lieu of the Application Fee. Proposed modifications that could result in assessment of a Subsequent Application Fee would cause BellSouth to analyze the following but are not limited to: floor loading changes, changes to HVAC requirements, power requirement changes which may result in a power plant upgrade, environmental or safety requirements, or equipment relocation. Should the Subsequent Application Fee not be included as part of this Attachment, Adelphia will be assessed the full Application Fee for all subsequent activity for completed arrangements.
- (2) **Space Enclosure Fee:** The Space Enclosure Construction Fee is a monthly recurring fee, assessed per enclosure, per location with a one-hundred (100) square foot minimum enclosure. It recovers costs associated with providing an optional equipment arrangement enclosure, which include architectural and engineering fees, materials, and installation costs. The cost for additional square feet is applicable only when ordered with the first 100 square feet and must be requested in fifty (50) square foot increments. Adelphia may, at its option, arrange with a BellSouth Certified Contractor to construct the space enclosure in accordance with BellSouth's guidelines and specifications. In this event, the BellSouth Certified Contractor shall directly bill Adelphia for the space enclosure, and this fee shall not be applicable.
- (3) **Co-Carrier Cross-Connect.** As stated in Section 5 of the Collocation Attachment, Adelphia may connect to other CLECs within the designated Premises in addition to, and not in lieu of, interconnection to BellSouth services and facilities. Where BellSouth must construct a cable rack structure to house the co-Carrier cross-connection, construction charges will be applied on an individual case basis as described in Section 5.6.1 of the Collocation Attachment. BellSouth shall provide an estimate of these charges in the Application Response. Where an existing cable rack structure is in place and has sufficient capacity to accommodate the co-Carrier cross-connection requested, the recurring charges as stated in this Exhibit A shall apply.
- (4) **Additional Engineering Fee:** BellSouth's additional engineering, and other labor costs associated with handling Adelphia-requested modifications to requests in progress or augmentations for existing arrangements shall be recovered as Additional Engineering charges, under provisions in BellSouth's F.C.C. Number 1 Tariff, Sections 13.1 and 13.2.

ENVIRONMENTAL AND SAFETY PRINCIPLES

The following principles provide basic guidance on environmental and safety issues when applying for and establishing Physical Collocation arrangements.

1. GENERAL PRINCIPLES

1.1 Compliance with Applicable Law. BellSouth and Adelphia agree to comply with applicable federal, state, and local environmental and safety laws and regulations including U.S. Environmental Protection Agency (USEPA) regulations issued under the Clean Air Act (CAA), Clean Water Act (CWA), Resource Conservation and Recovery Act (RCRA), Comprehensive Environmental Response, Compensation and Liability Act (CERCLA), Superfund Amendments and Reauthorization Act (SARA), the Toxic Substances Control Act (TSCA), and OSHA regulations issued under the Occupational Safety and Health Act of 1970, as amended and NFPA and National Electrical Codes (NEC) and the NESC ("Applicable Laws"). Each party shall notify the other if compliance inspections are conducted by regulatory agencies and/or citations are issued that relate to any aspect of this agreement.

1.2 Notice. BellSouth and Adelphia shall provide notice to the other, including Material Safety Data Sheets (MSDSs), of known and recognized physical hazards or Hazardous Chemicals existing on site or brought on site. Each party is required to provide specific notice for known potential Imminent Danger conditions. Adelphia should contact 1-800-743-6737 for BellSouth MSDS sheets.

1.3 Practices/Procedures. BellSouth may make available additional environmental control procedures for Adelphia to follow when working at a BellSouth Premises (See Section 2, below). These practices/procedures will represent the regular work practices required to be followed by the employees and contractors of BellSouth for environmental protection. Adelphia will require its contractors, agents and others accessing the BellSouth Premises to comply with these practices. Section 2 lists the Environmental categories where BST practices should be followed by CLEC when operating in the BellSouth Premises.

1.4 Environmental and Safety Inspections. BellSouth reserves the right to inspect the Adelphia space with proper notification. BellSouth reserves the right to stop any Adelphia work operation that imposes Imminent Danger to the environment, employees or other persons in the area or Facility.

1.5 Hazardous Materials Brought On Site. Any hazardous materials brought into, used, stored or abandoned at the BellSouth Premises by Adelphia are owned by Adelphia. Adelphia will indemnify BellSouth for claims, lawsuits or damages to persons or property caused by these materials. Without prior written BellSouth approval, no substantial new safety or environmental hazards can be created by Adelphia or different hazardous materials used by Adelphia at BellSouth Facility. Adelphia must demonstrate adequate emergency response capabilities for its materials used or remaining at the BellSouth Facility.

EXHIBIT B
Page 2 of 4

1.6 Spills and Releases. When contamination is discovered at a BellSouth Premises, the party discovering the condition must notify BellSouth. All Spills or Releases of regulated materials will immediately be reported by Adelphia to BellSouth.

1.7 Coordinated Environmental Plans and Permits. BellSouth and Adelphia will coordinate plans, permits or information required to be submitted to government agencies, such as emergency response plans, spill prevention control and countermeasures (SPCC) plans and community reporting. If fees are associated with filing, BellSouth and Adelphia will develop a cost sharing procedure. If BellSouth's permit or EPA identification number must be used, Adelphia must comply with all of BellSouth's permit conditions and environmental processes, including environmental "best management practices (BMP)" (see Section 2, below) and/or selection of BST disposition vendors and disposal sites.

1.8 Environmental and Safety Indemnification. BellSouth and Adelphia shall indemnify, defend and hold harmless the other party from and against any claims (including, without limitation, third-party claims for personal injury or death or real or personal property damage), judgments, damages, (including direct and indirect damages, and punitive damages), penalties, fines, forfeitures, costs, liabilities, interest and losses arising in connection with the violation or alleged violation of any Applicable Law or contractual obligation or the presence or alleged presence of contamination arising out of the acts or omissions of the indemnifying party, its agents, contractors, or employees concerning its operations at the Facility.

2. CATEGORIES FOR CONSIDERATION OF ENVIRONMENTAL ISSUES

When performing functions that fall under the following Environmental categories on BellSouth's Premises, Adelphia agrees to comply with the applicable sections of the current issue of BellSouth's Environmental and Safety Methods and Procedures (M&Ps), incorporated herein by this reference. Adelphia further agrees to cooperate with BellSouth to ensure that Adelphia's employees, agents, and/or subcontractors are knowledgeable of and satisfy those provisions of BellSouth's Environmental M&Ps which apply to the specific Environmental function being performed by Adelphia, its employees, agents and/or subcontractors.

The most current version of reference documentation must be requested from BellSouth.

EXHIBIT B
Page 3 of 4

2. Categories for Consideration of Environmental Issues (cont.)

| ENVIRONMENTAL CATEGORIES | ENVIRONMENTAL ISSUES | ADDRESSED BY THE FOLLOWING DOCUMENTATION |
|---|--|---|
| Disposal of hazardous material or other regulated material (e.g., batteries, fluorescent tubes, solvents & cleaning materials) | Pollution liability insurance EVET approval of contractor | Std T&C 450 GU-BTEN-001BT, Chapter 4 Std T&C 660-3 GU-BTEN-001BT, Chapter 10 |
| Emergency response | Hazmat/waste release/spill firesafety emergency | GU-BTEN-001BT, Chapter Building Emergency Operations Plan (EOP) (specific to Premises) |
| Contract labor/outsourcing for services with environmental implications to be performed on BellSouth Premises (e.g., disposition of hazardous material/waste; maintenance of storage tanks) | Performance of services in accordance with BST's environmental M&Ps Insurance | Std T&C 450 Std T&C 450-B (Contact E/S or your DEC/LDEC for copy of appropriate E/S M&Ps.) Std T&C 660 |
| Transportation of hazardous material | Pollution liability insurance EVET approval of contractor | Std T&C 450 GU-BTEN-001BT, Chapter 4 Std T&C 660-3 GU-BTEN-001BT, Chapter 10 |
| Maintenance/operations work which may produce a waste Other maintenance work | Protection of BST employees and equipment | Std T&C 450 GU-BTEN-001BT, Chapter 10 29CFR 1910.147 29CFR 1910 Subpart O |
| Janitorial services | All waste removal and disposal must conform to all applicable federal, state and local regulations All HazMat & Waste Asbestos notification protection of BST employees and equipment | P&SM Manager – Procurement GU-BTEN-001BT, Chapter 4, GU-BTEN-001BT, Chapter 3 BSP 010-170-001BS (Hazcom) |
| Manhole cleaning | Pollution liability insurance Manhole entry requirements EVET approval of contractor | Std T&C 450 Std T&C 660-3 BSP 620-145-011PR Issue A, August 1996 GU-BTEN-001BT, Chapter 10 RL9706008BT |
| Removing or disturbing building materials that may contain asbestos | Asbestos work practices | GU-BTEN-001BT, Chapter 3 |

3. **DEFINITIONS**

Generator. Under RCRA, the person whose act produces a Hazardous Waste, as defined in 40 CFR 261, or whose act first causes a Hazardous Waste to become subject to regulation. The Generator is legally responsible for the proper management and disposal of Hazardous Wastes in accordance with regulations.

Hazardous Chemical. As defined in the U.S. Occupational Safety and Health (OSHA) hazard communication standard (29 CFR 1910.1200), any chemical which is a health hazard or physical hazard.

Hazardous Waste. As defined in section 1004 of RCRA.

Imminent Danger. Any conditions or practices at a facility which are such that a danger exists which could reasonably be expected to cause immediate death or serious harm to people or immediate significant damage to the environment or natural resources.

Spill or Release. As defined in Section 101 of CERCLA.

4. **ACRONYMS**

DEC/LDEC - Department Environmental Coordinator/Local Department Environmental Coordinator

GU-BTEN-001BT - BellSouth Environmental Methods and Procedures

EVET - Environmental Vendor Evaluation Team

P&SM - Property & Services Management

Std. T&C - Standard Terms & Conditions

NESC - National Electrical Safety Codes

Attachment 5
Access to Numbers and Number Portability

TABLE OF CONTENTS

1. Non-Discriminatory Access To Telephone Numbers..... 3

2. Number Portability Permanent Solution 3

3. Service Provider Number Portability..... 4

4. SPNP Implementation 4

5. Transition To Permanent Number Portability 7

6. True-Up..... 7

7. Operational Support System (OSS) Rates..... 8

Rates.....Exhibit A

ACCESS TO NUMBERS AND NUMBER PORTABILITY

1. Non-Discriminatory Access to Telephone Numbers

All the negotiated rates, terms and conditions set forth in this Attachment pertain to the provisioning of local number portability.

- 1.1 During the term of this Agreement, each Party shall contact the North American Numbering Plan Administrator, currently Neustar, for the assignment of numbering resources. In order to be assigned a Central Office Code, each Party will be required to complete the Central Office Code (NXX) Assignment Request and Confirmation Form (Code Request Form) in accordance with Industry Numbering Committee's Central Office Code (NXX) Assignment Guidelines (INC 95-0407-008).
- 1.2 For the purposes of the resale of BellSouth's telecommunications services by Adelphia, BellSouth will provide Adelphia with on line access to telephone numbers for reservation on a first come first served basis. Such reservations of telephone numbers, on a pre-ordering basis shall be for a period of ninety (90) days. Where there is a shortage of telephone numbers in a particular Common Language Location Identifier Code ("CLLIC") both Parties may be forced to cancel their reservations of numbers. So long as BellSouth applies the shortage policy to itself and other CLECs on a non-discriminatory basis, Adelphia shall comply with BellSouth requests to release telephone number reservations.
- 1.3 Further, upon Adelphia request and for the purposes of the resale of BellSouth's telecommunications services by Adelphia, BellSouth will reserve up to 100 telephone numbers per CLLIC, for Adelphia's sole use. Such telephone number reservations shall be transmitted to Adelphia via electronic file transfer. Such reservations shall be valid for ninety (90) days from the reservation date. Where there is a shortage of telephone numbers in a particular CLLIC BellSouth shall use its best efforts to reserve for a ninety (90) day period a sufficient quantity for Adelphia's reasonable need in that particular CLLIC. BellSouth will apply any policies to address such shortages on a non-discriminatory basis to itself, Adelphia, and other CLECs.

2. Number Portability Permanent Solution

- 2.1 The FCC, the Commissions, and industry forums have developed and BellSouth is implementing a permanent approach to providing service provider number portability. Both Parties will implement, in accordance with the Act and applicable rules, a permanent approach as developed and approved by the Commission, the FCC and industry forums. Consistent with the requirements to move to Permanent Number Portability (PNP) as set forth in Section 5 of this Attachment and in FCC rules and orders, Interim Service Provider Number Portability (SPNP) may be available only until such permanent solution is implemented in a switch.

2.2 End User Line Charge. Recovery of charges associated with implementing PNP through a monthly charge assessed to end users has been authorized by the FCC. This end user line charge will be as filed in BellSouth's Tariff FCC No. 1 and will be billed to Adelphia where Adelphia is a subscriber to local switching or where Adelphia is a reseller of BellSouth telecommunications services. This charge will not be discounted.

3. Service Provider Number Portability

3.1 Definition. Until the industry-wide permanent solution is implemented in a switch, BellSouth shall provide Service Provider Number Portability ("SPNP"). SPNP is an interim service arrangement whereby an end user who switches subscription of his local exchange service from BellSouth to a CLEC, or vice versa, is permitted to retain the use of his existing assigned telephone number, provided that the end user remains at the same location for his local exchange service or changes locations and service providers but stays within the same serving wire center of his existing number.

3.2 Methods of Providing Number Portability. SPNP is available through either remote call forwarding or direct inward dialing trunks, at the election of Adelphia. Remote call forwarding (SPNP-RCF) is an existing switch-based BellSouth service that redirects calls within the telephone network. Direct inward dialing trunks (SPNP-DID) allow calls to be routed over a dedicated facility to the Adelphia switch that serves the subscriber.

3.3 Signaling Requirements. SS7 Signaling is required for the provision of SPNP services. SPNP-DID is available from BellSouth on a per DS0, DS1, or DS3 basis. Where SPNP-DID is technically feasible and is provided on a DS1 or a DS3 basis, the applicable channelization rates are those specified in Section E6 in BellSouth's Intrastate Access Tariffs, incorporated herein by this reference. SPNP is available only for basic local exchange service.

3.4 Rates

Rates for SPNP are set out in Exhibit A to this Attachment.

4. SPNP Implementation

4.1 SPNP is available only where a CLEC or BellSouth is currently providing, or will begin providing concurrent with provision of SPNP, basic local exchange service to the affected end user. SPNP for a particular telephone number is available only from the central office originally providing local exchange service to the end user. SPNP for a particular assigned telephone number will be disconnected when any end user, Commission, BellSouth, or CLEC initiated activity (*e.g.*, a change in exchange boundaries) would normally result in a telephone number change had the end user retained his initial local exchange service.

4.2 SPNP-RCF, as contemplated by this Agreement, is a telecommunications service whereby a call dialed to an SPNP-RCF equipped telephone number is automatically

- forwarded to an assigned seven- or ten- digit telephone number within the local calling area as defined in BellSouth's General Subscriber Services Tariff. The forwarded-to number shall be specified by the CLEC or BellSouth, as appropriate. The forwarding Party will provide identification of the originating telephone number, via SS7 signaling, to the receiving Party. Identification of the originating telephone number to the SPNP-RCF end user cannot be guaranteed, however. SPNP-RCF provides a single call path for the forwarding of no more than one simultaneous call to the receiving Party's specified forwarded-to number.
- 4.3 SPNP-DID service, as contemplated by this Agreement, provides trunk side access to end office switches for direct inward dialing to the other Party's premises equipment from the telecommunications network to lines associated with the other Party's switching equipment and must be provided on all trunks in a group arranged for inward service. A SPNP-DID trunk termination charge, provided with SS7 Signaling only, applies for each trunk voice grade equivalent. In addition, direct facilities are required from the end office where a ported number resides to the end office serving the ported end user customer. The rates for a local channel and dedicated transport are as set forth in Exhibit C of Attachment 2. Transport mileage will be calculated as the airline distance between the end office where the number is ported and the Point of Interface ("POI") using the V&H coordinate method. SPNP-DID must be established with a minimum configuration of two channels and one unassigned telephone number per switch, per arrangement for control purposes. Transport facilities arranged for SPNP-DID may not be mixed with any other type of trunk group, with no outgoing calls placed over said facilities. SPNP-DID will be provided only where such facilities are available. Where SPNP-DID service is required from more than one wire center or from separate trunk groups within the same wire center, such service provided from each wire center or each trunk group within the same wire center shall be considered a separate service. Only customer-dialed sent-paid calls will be completed to the first number of a SPNP-DID number group; however, there are no restrictions on calls completed to other numbers of a SPNP-DID number group. Sent-paid calls refer to those calls placed by an end user who physically deposits currency in a public telephone. Interface group arrangements provided for terminating the switched transport at the Party's terminal location are as set forth in of BellSouth's Intrastate Access Services Tariff, § E6.1.3.A as amended from time to time.
- 4.3.1 SPNP-DID Service requires ordering consecutive telephone numbers in blocks of twenty. To order non-consecutive telephone numbers or telephone numbers in less than blocks of twenty, the NBR process must be used. SS7 Signaling is required for the provision of either of these services.
- 4.4 The calling Party shall be responsible for payment of the applicable charges for sent-paid calls to the SPNP number. For collect, third-party, or other operator-assisted non-sent paid calls to the ported telephone number, BellSouth or the CLEC shall be responsible for the payment of charges under the same terms and conditions for which the end user would have been liable for those charges. Either Party may request that the other block collect and third party non-sent paid calls to the SPNP-assigned

- telephone number. If a Party does not request blocking, the other Party will provide itemized local usage detail for the billing of non-sent paid calls on the monthly bill of usage charges provided at the individual end user account level. The detail will include itemization of all billable usage. Each Party shall have the option of receiving this usage data on a daily basis via a data file transfer arrangement. This arrangement will utilize the existing industry uniform standard, known as EMR standards, for exchange of billing data. Files of usage data will be created daily for the optional service. Usage originated and recorded in the sending BellSouth RAO will be provided in unrated or rated format, depending on processing system. CLEC usage originated elsewhere and delivered via CMDS to the sending BellSouth RAO shall be provided in rated format.
- 4.5 Each Party shall be responsible for obtaining authorization from the end user for the handling of the disconnection of the end user's service, the provision of new local service and the provision of SPNP services. Each Party shall be responsible for coordinating the provision of service with the other to assure that its switch and other equipment and facilities are capable of accepting SPNP ported traffic. Neither Party shall be responsible for its inability to port calls to the other Party when such inability is caused by inadequate or insufficient equipment or facilities of the other Party. In the event that either Party determines in its reasonable judgment that the other Party will likely impair or is impairing, or interfering with any equipment, facility or service or any of its end users, that Party may either refuse to provide SPNP service or may terminate SPNP service to the other Party after providing thirty (30) days' prior written notice.
- 4.6 Each Party shall be responsible for providing an appropriate intercept announcement service for any telephone numbers subscribed to SPNP services for which it is not presently providing local exchange service or terminating to an end user. Where either Party chooses to disconnect or terminate any SPNP service, that Party shall be responsible for designating the preferred standard type of announcement to be provided.
- 4.7 Neither Party shall be responsible for adverse effects on any service, facility or equipment from the use of SPNP services. End-to-end transmission characteristics may vary depending on the distance and routing necessary to complete calls over SPNP facilities and the fact that another carrier is involved in the provisioning of service. Therefore, end-to-end transmission characteristics cannot be specified by either Party for such calls. Neither Party shall be responsible to the other if any necessary change in protection criteria or in any of the facilities, operation, or procedures of either renders any facilities provided by the other Party obsolete or renders necessary modification of the other Party's equipment.
- 4.8 For terminating IXC traffic ported to either Party which requires use of either Party's tandem switching, the tandem provider will bill the IXC tandem switching, the interconnection charge, and a portion of the transport, and the other Party will bill the IXC local switching, the carrier common line and a portion of the transport. If the

tandem provider is unable to provide the necessary access records to permit the other Party to bill the IXC directly for terminating access to ported numbers, then the tandem provider will bill the IXC full terminating switched access charges at the tandem provider's rate and will compensate the other Party at the tandem Party's tariff rates via a process used by BellSouth to estimate the amount of ported switched access revenues due the other Party. If an intraLATA toll call is delivered, the delivering Party will pay terminating access rates to the other Party. This subsection does not apply in cases where SPNP-DID is utilized for number portability.

5. Transition to Permanent Number Portability

- 5.1 Once a PNP is implemented in a switch both Parties must withdraw their SPNP offerings for that switch to the extent required under the Act and FCC rules and orders. The transition from existing SPNP arrangements to PNP shall occur within one hundred twenty (120) days from the date PNP is implemented in the switch. Neither Party shall charge the other Party for conversion from SPNP to PNP. The Parties shall comply with any SPNP/PNP transition processes established by the FCC and State commissions and appropriate industry number portability work groups.
- 5.2 Notwithstanding the foregoing, the Parties acknowledge that the FCC has determined once LNP has been deployed pursuant to the FCC's orders, rules and regulations, that all local exchange carriers (LECs) have the duty to provide LNP consistent with the directives of the FCC in those orders and rules. Therefore, either Party, at any time, may seek appropriate legal or regulatory relief concerning the transition from INP to LNP or other related issues.

6. True-up

This section applies only to Tennessee and other rates that are interim or expressly subject to true-up under this attachment.

- 6.1 The interim prices for Network Elements and Other Services and Local Interconnection shall be subject to true-up according to the following procedures:

The interim prices shall be trued-up, either up or down, based on final prices determined either by further agreement between the Parties, or by a final order (including any appeals) of the Commission which final order meets the criteria of Section 6.3 below. The Parties shall implement the true-up by comparing the actual volumes and demand for each item, together with interim prices for each item, with the final prices determined for each item. Each Party shall keep its own records upon which the true-up can be based, and any final payment from one Party to the other shall be in an amount agreed upon by the Parties based on such records. In the event of any disagreement as between the records or the Parties regarding the amount of such true-up, the Parties agree that the body having jurisdiction over the matter shall be called upon to resolve such differences, or the Parties may mutually agree to submit the matter to the Dispute Resolution process in accordance with the provisions in the General Terms and Conditions and Attachment 1 of this Agreement.

- 6.2 The Parties may continue to negotiate toward final prices, but in the event that no such agreement is reached within nine (9) months, either Party may petition the Commission to resolve such disputes and to determine final prices for each item. Alternatively, upon mutual agreement, the Parties may submit the matter to the Dispute Resolution Process set forth in the General Terms and Conditions and Attachment 1 of the Agreement, so long as they file the resulting Agreement with the Commission as a “negotiated Agreement” under Section 252(e) of the Act.
- 6.3 A final order of this Commission that forms the basis of a true-up shall be the final order as to prices based on appropriate cost studies, or potentially may be a final order in any other Commission proceeding which meets the following criteria:
- (a) BellSouth and CLEC is entitled to be a full Party to the proceeding;
 - (b) It shall apply the provisions of the federal Telecommunications Act of 1996, including but not limited to Section 252(d)(1) (which contains pricing standards) and all then-effective implementing rules and regulations; and,
 - (c) In the case of loops only, it shall include as an issue the geographic deaveraging of network element prices, which deaveraged prices, if any are required by said final order, shall form the basis of any true-up.

7. Operational Support System (OSS) Rates

BellSouth has developed and made available the following mechanized systems by which Adelphia may submit LSRs electronically.

- LENS Local Exchange Navigation System
- EDI Electronic Data Interchange

- TAG Telecommunications Access Gateway

LSRs submitted by means of one of these interactive interfaces will incur an OSS electronic ordering charge as specified in the table below. An individual LSR will be identified for billing purposes by its Purchase Order Number (PON). LSRs submitted by means other than one of these interactive interfaces (mail, fax, courier, etc.) will incur a manual order charge as specified in the table below:

| OPERATIONAL SUPPORT SYSTEMS | AL, GA, LA, MS, SC | FL, KY, NC, TN |
|---|-----------------------------|-----------------------|
| OSS LSR charge, per LSR received from the CLEC by one of the OSS interactive interfaces | \$3.50 | \$3.50 |
| | SOME C | SOME C |
| Incremental charge per LSR received from the CLEC by means other than one of the OSS interactive interfaces | See applicable rate element | \$19.99 |
| | | SOMAN |

Note: In addition to the OSS charges, applicable discounted service order and related discounted charges apply per the tariff.

Denial/Restoral OSS Charge

In the event Adelphia provides a list of customers to be denied and restored, rather than an LSR, each location on the list will require a separate PON and, therefore will be billed as one LSR per location.

Cancellation OSS Charge

Adelphia will incur an OSS charge for an accepted LSR that is later canceled by Adelphia.

Note: Supplements or clarifications to a previously billed LSR will not incur another OSS charge.

Network Elements and Other Services Manual Additive

The Commissions in Alabama, Georgia, Louisiana, Mississippi and South Carolina have ordered incremental manual non-recurring charges (NRC) for network elements and other services ordered by means other than one of the interactive interfaces. These ordered network elements and other services manual additive NRCs will apply in these states, rather than the charge per LSR submitted by means other than the OSS interactive interface, as set forth above.

Threshold Billing Plan

The Parties agree that Adelphia will incur the mechanized rate for all LSRs, both mechanized and manual, if the percentage of mechanized LSRs to total LSRs meets or exceeds the threshold percentages shown below:

| Year | Ratio: Mechanized/Total LSRs |
|------|------------------------------|
| 2000 | 80% |
| 2001 | 90% |

The threshold plan will be discontinued in 2002.

BellSouth will track the total LSR volume for each CLEC for each quarter. At the end of that time period, a Percent Electronic LSR calculation will be made for that quarter based on the LSR data tracked in the LCSC. If this percentage exceeds the threshold volume, all of that CLECs' future manual LSRs will be billed at the mechanized LSR rate. To allow time for obtaining and analyzing the data and updating the billing system, this billing change will take place on the first day of the second month following the end of the quarter (e.g. May 1 for 1Q, Aug 1 for 2Q, etc.). There will be no adjustments to the amount billed for previously billed LSRs.

BELLSOUTH/ADELPHIA RATES
SERVICE PROVIDER
NUMBER PORTABILITY

| DESCRIPTION | USOC | KY |
|---|---------------------------------|----|
| INTERIM SERVICE PROVIDER NUMBER PORTABILITY - RCF (1) (2) | | |
| RCF, per number ported (Business Line), 10 paths | TNPBL | NA |
| RCF, per number ported (Residence Line), 6 paths | TNPRL | NA |
| RCF, per number ported (Business Line) | TNPBL | NA |
| NRC - Electronic | TNPBL | NA |
| NRC - Disconnect Charge | TNPBL | NA |
| RCF, per number ported (Residence Line) | TNPRL | NA |
| NRC | TNPRL | NA |
| NRC - Disconnect Charge | TNPRL | NA |
| RCF, add'l capacity for simultaneous call forwarding, per additional path | N/A | NA |
| RCF, per service order, per location | (++) Bus = TNPBD Res = TNPRD | |
| NRC - 1st | TNP++ | NA |
| NRC - Add'l | TNP++ | NA |
| NRC - Disconnect - 1st | TNP++ | NA |
| NRC - Disconnect - Add'l | TNP++ | NA |
| NRC - Incremental Charge - Manual Service Order - 1st | SOMAN | NA |
| NRC - Incremental Charge - Manual Service Order - Add'l | SOMAN | NA |
| NRC - Incremental Charge - Manual Service Order - Disconnect - 1st | SOMAN | NA |
| NRC - Incremental Charge - Manual Service Order - Disconnect - Add'l | SOMAN | NA |
| INTERIM SERVICE PROVIDER NUMBER PORTABILITY - DID | | |
| DID per number ported, Residence - NRC | TNPDR | NA |
| DID per number ported, Residence - NRC - Disconnect | TNPDR | NA |
| DID per number ported, Business - NRC | TNPDB | NA |
| DID per number ported, Business - NRC - Disconnect | TNPDB | NA |
| DID per service order, per location | | |
| NRC - 1st | TNPRD | NA |
| NRC - Add'l | TNPRD | NA |
| NRC - Disconnect - 1st | TNPRD | NA |
| NRC - Disconnect - Add'l | TNPRD | NA |
| NRC - Incremental Charge - Manual Service Order - 1st | SOMAN | NA |
| NRC - Incremental Charge - Manual Service Order - Add'l | SOMAN | NA |
| NRC - Incremental Charge - Manual Service Order - Disconnect - 1st | SOMAN | NA |
| NRC - Incremental Charge - Manual Service Order - Disconnect - Add'l | SOMAN | NA |
| DID, per trunk termination, Initial | TNPT2 | NA |
| DID, per trunk termination, Initial - NRC | TNPT2 | NA |
| DID, per trunk termination, Initial - Disconnect | TNPT2 | NA |
| DID, per trunk termination, Subsequent | TNPT2 | NA |
| DID, per trunk termination, Subsequent - NRC | TNPT2 | NA |
| DID, per trunk termination, Subsequent - Disconnect | TNPT2 | NA |

NOTES:

If no rate is identified in the contract, the rate for the specific service or function will be as set forth in applicable BellSouth tariff or as negotiate

1 Until the FCC issues its order implementing a cost recovery mechanism for permanent number portability, the Company will track its costs of providing interim SPNP with sufficient detail to verify the costs. This will facilitate the Florida PSCs consideration of the recovery of these costs in Docket 950737-TP. (FL)

2 BellSouth and CLEC will each bear their own costs of providing remote call forwarding as an interim number portability option. (KY)

Attachment 6
Ordering and Provisioning

TABLE OF CONTENTS

1. Quality of Ordering And Provisioning 3

2. Access To Operational Support Systems 3

3. Miscellaneous Ordering And Provisioning Guidelines..... 5

ORDERING AND PROVISIONING

1. Quality of Ordering and Provisioning

- 1.1 All the negotiated terms and conditions set forth in this Attachment pertain to ordering and provisioning.
- 1.2 BellSouth shall provide ordering and provisioning services to Adelphia that are equal to the ordering and provisioning services BellSouth provides to itself or any other carrier. Detailed guidelines for ordering and provisioning are set forth in BellSouth's Local Interconnection and Facility Based Ordering Guide and Resale Ordering Guide, as appropriate, and as they are amended from time to time during this Agreement.

BellSouth will perform provisioning services during the following normal hours of operation:

Monday - Friday: 8:00AM - 6:00 PM location time (excluding holidays)
(Resale/Network Element non coordinated, coordinated orders and order coordinated - Time Specific)

Saturday: 8:00 AM - 6:00 PM location time (excluding holidays) (for resale/UNE non-coordinated orders)

Times are either Eastern or Central time based on the location of the work being performed.

- 1.3 All other Adelphia requests for provisioning services are considered outside of the normal hours of operation and may be performed subject to the application of overtime charges set forth in BellSouth Tariff FCC No. 1.
- 1.4 It is understood and agreed that BellSouth technicians involved in provisioning service to Adelphia may work shifts outside of BellSouth's regular working hours as defined in Section 1.2 above (e.g., the employee's shift ends at 7:00 p.m. during daylight savings time). To the extent that Adelphia requests that work necessarily required in the provisioning of service be performed outside BellSouth's regular working hours and that work is performed by a BellSouth technician during his or her scheduled shift such that BellSouth does not incur any additional costs in performing the work on behalf of Adelphia, BellSouth will not assess Adelphia additional overtime charges beyond the rates and charges specified in this Agreement.

2. Access to Operational Support Systems

- 2.1 BellSouth shall provide Adelphia access to several operations support systems. Access to these support systems is available through a variety of means, including electronic interfaces. BellSouth also provides the option of placing orders manually (e.g., via facsimile) through the Local Carrier Service Center. The operations support systems available are:
- 2.2 Pre-Ordering. BellSouth provides electronic access to the following pre-ordering functions: service address validation, telephone number selection, service and feature availability, due date information, and upon Commission approval of confidentiality protections, to customer record information. Access is provided through the Local Exchange Navigation System (LENS) and the Telecommunications Access Gateway (TAG). Customer record information includes Customer Record Information but is not limited to, customer specific information in CRIS and RSAG.. In addition, Adelphia shall provide to BellSouth access to customer record information including electronic access where available. Otherwise, Adelphia shall provide paper copies of customer record information within a reasonable period of time upon request by BellSouth. Customer Record Information is equivalent to but not limited to the type of customer specific information contained in CRIS and RSAG. The parties agree not to view, copy, or otherwise obtain access to the customer record information of any customer without that customer's permission and further agrees that Adelphia and BellSouth will obtain access to customer record information only in strict compliance with applicable laws, rules, or regulations of the State in which the service is provided.
- 2.3 Service Ordering and Provisioning. BellSouth provides electronic options for the exchange of ordering and provisioning information. BellSouth provides an Electronic Data Interchange (EDI) arrangement for resale requests and certain network elements and other services. The EDI interface can be integrated with the TAG pre-ordering interface by Adelphia. BellSouth provides integrated pre-ordering, ordering and provisioning capability through the LENS interface.
- 2.4 Service Trouble Reporting and Repair. Service trouble reporting and repair allows Adelphia to report and monitor service troubles and obtain repair services. BellSouth shall offer Adelphia service trouble reporting in a non-discriminatory manner that provides Adelphia the equivalent ability to report and monitor service troubles that BellSouth provides to itself, its affiliates and any other carrier. BellSouth also provides Adelphia an estimated time to repair, an appointment time or a commitment time, as appropriate, on trouble reports. BellSouth provides two options for electronic trouble reporting. For exchange services, BellSouth offers Adelphia access to the Trouble Analysis Facilitation Interface (TAFI). For individually designed services, BellSouth provides electronic trouble reporting through an electronic communications gateway. If Adelphia requests BellSouth to repair a trouble after normal working hours, Adelphia will be billed the appropriate overtime charges associated with this request at the rates set forth in BellSouth Tariff FCC No. 1.
- 2.5 Migration of Adelphia to New BellSouth Software Releases for National Standard Machine-to-Machine Electronic Interfaces. BellSouth will issue new software releases

for new national standards its national standard, machine-to-machine electronic interfaces as needed to improve operations and meet standards and regulatory requirements. When a new release of new national standards is implemented, BellSouth will continue to support both the new release (N) and the prior release (N-1). When BellSouth makes the next release (N+1), BellSouth will eliminate support for the (N-1) release and support the two newest releases (N and N+1). Thus, BellSouth will always support the two most current releases. BellSouth will issue documents to Adelphia advising Adelphia of the release date of N+1 and the discontinue date of N-1 no less than thirty (30) days prior to the new release to allow Adelphia to make the necessary changes to their systems and operations to migrate to the newest release in a timely fashion.

2.6 Rates. Charges for use of Operational Support Systems shall be as set forth in Attachments 1 and 2 of this Agreement.

2.7 Adelphia, by written notice to its account manager, may assign to a third party agent the right to access BellSouth's OSS on Adelphia's behalf for purposes of establishing interfaces and placing Adelphia orders for interconnection, UNEs and services provided under this Agreement. BellSouth will provide Adelphia's third party agent the same nondiscriminatory access to OSS that BellSouth provides to Adelphia and other CLECs. Such agent shall utilize BellSouth's OSS using Adelphia's ACNAs, CIC, and OCNs and shall be bound by all the terms, conditions, and requirements set forth in this Agreement relating to OSS.

3. Miscellaneous Ordering and Provisioning Guidelines

3.1 Pending Orders. To ensure the most efficient use of facilities and resources, orders placed in the hold or pending status by Adelphia will be held for a maximum of thirty (30) days from the date the order is placed on hold. After such time, if Adelphia wishes to reinstate an order, Adelphia may be required to submit a new service order.

3.2 Single Point of Contact. Adelphia will be the single point of contact with BellSouth for ordering activity for network elements and other services used by Adelphia to provide services to its end users, except that BellSouth may accept an order directly from another CLEC, or BellSouth, acting with authorization of the affected end user. If they have not already done so, Adelphia and BellSouth shall each execute a blanket letter of authorization with respect to customer orders. The Parties shall each be entitled to adopt their own internal processes for verification of customer authorization for orders, provided, however, that such processes shall comply with applicable state and federal law including, until superseded, the FCC guidelines and orders applicable to Presubscribed Interexchange Carrier (PIC) changes including Un-PIC. Pursuant to such an order, BellSouth may disconnect any network element associated with the service to be disconnected and being used by Adelphia to provide service to that end user and reuse such network elements or facilities to enable such other LEC to provide service to the end user. BellSouth will notify Adelphia that such

- an order has been processed, but will not be required to notify Adelphia in advance of such processing.
- 3.3 Use of Facilities. When a customer of a CLEC elects to discontinue service and transfer service to another local exchange carrier, including BellSouth, BellSouth shall have the right to reuse the facilities provided to CLEC by BellSouth for retail or resale service, loop and/or port for that customer. In addition, BellSouth may disconnect and reuse facilities when the facility is in a denied state and BellSouth has received an order to establish new service or transfer of service from a customer or a customer's CLEC at the same address served by the denied facility.
- 3.3.1 Upon receipt of a service order that results in a disconnect of an Adelphia customer that was served, in whole or in part, by use of BellSouth facilities or service, BellSouth will do the following:
- 3.3.1.1 Process disconnect and reconnect orders to provision the service which shall be due dated using current interval guidelines in the Guides.
- 3.3.1.2 Reuse the serving facility for the retail, resale service, or network element at the same location.
- 3.3.1.3 Notify Adelphia with five (5) business days after the disconnect order is completed.
- 3.4 Contact Numbers. The Parties agree to provide one another with toll-free contact numbers for the purpose of ordering, provisioning and maintenance of services.
- 3.5 Subscription Functions. In cases where BellSouth performs subscription functions for an inter-exchange carrier (i.e. PIC and LPIC changes via Customer Account Record Exchange (CARE)), BellSouth will provide the affected inter-exchange carriers with the Operating Company Number (OCN) of the local provider for the purpose of obtaining end user billing account and other end user information required under subscription requirements.
- 3.6 Cancellation Charges. If Adelphia cancels an order for network elements or other services, BellSouth may recover, consistent with the methodology set forth in BellSouth Tariff FCC No. 1, Section 5.4, any reasonable and demonstrable costs incurred by BellSouth in conjunction with the provisioning of that order prior to cancellation.

Attachment 7
Billing and Billing Accuracy Certification

TABLE OF CONTENTS

| | |
|--|------------------|
| 1. Payment and Billing Arrangements..... | 3 |
| 2. Billing Accuracy Certification..... | 6 |
| 3. Billing Disputes..... | 7 |
| 4. RAO Hosting | 8 |
| 5. Optional Daily Usage File..... | 12 |
| 6. Access Daily Usage File..... | 15 |
| 7. Enhanced Optional Daily Usage File | 18 |
| Rates..... | Exhibit A |

BILLING AND BILLING ACCURACY CERTIFICATION

1. Payment and Billing Arrangements

All negotiated rates, terms and conditions set forth in this Attachment pertain to billing and billing accuracy certifications.

1.1 **Billing.** BellSouth agrees to provide billing through the Carrier Access Billing System (CABS) and through the Customer Records Information System (CRIS) depending on the particular service(s) that Adelphia requests. BellSouth will bill and record in accordance with this Agreement those charges Adelphia incurs as a result of Adelphia purchasing from BellSouth Network Elements and Other Services as set forth in this Agreement. BellSouth will format all bills in CBOS Standard or CLUB/EDI format, depending on the type of service ordered. For those services where standards have not yet been developed, BellSouth's billing format will change as necessary when standards are finalized by the industry forum. BellSouth will provide Adelphia thirty (30) days' prior notice of billing format changes.

1.1.1 For any service(s) BellSouth orders from Adelphia, Adelphia shall bill BellSouth in CABS format or a format approximating industry standards for access billing to include (1) the following elements for facilities: circuit identification number; purchase order number (for new order only); due date (for new order only); total amount billed; total amount billed per rate element (broken down by monthly and nonrecurring rate elements); and (2) the following elements for usage: minutes of use; percent local usage; total amount billed for each rate element; total amount billed; and contract rate for each rate element. Adelphia reserves the right, in special and emergency circumstances, to issue bills in a manually-developed format.

Address for BellSouth receipt of bills:
Interconnection Purchasing Center
BellSouth
7th Floor
600 North 19th Street
Atlanta, GA 35203

Address for Adelphia receipt of bills:
Cost of Service Manager – Job Center
1 North Main Street
Coudersport, PA 16915

1.1.2 **Bill Media.** Each Party agrees to provide formatted bills in the other party's preferred media, if possible. Adelphia's preferred media is CD ROM. BellSouth preferred media is paper. In lieu of the preferred media, each Party agrees to accept bills on 3.5" disk or paper until the preferred media option becomes available. If either Party

- requests multiple billing media or additional copies of bills, the Billing Party will provide these at a reasonable cost.
- 1.1.2 If either Party requests multiple billing media or additional copies of bills, the Billing Party will provide these at a reasonable cost.
- 1.2 Master Account. After receiving certification as a local exchange company from the appropriate regulatory agency, where Adelphia has not already done so, it will provide the appropriate BellSouth account manager the necessary documentation to enable BellSouth to establish a master account for Local Interconnection, Network Elements and Other Services, and/or resold services. Such documentation shall include the Application for Master Account, proof of authority to provide telecommunications services, an Operating Company Number (“OCN”) assigned by the National Exchange Carriers Association (“NECA”), Carrier Identification Code (CIC), Access Customer Name and Address (ACNA) and a tax exemption certificate, if applicable. BellSouth will notify Adelphia within seven (7) business days of its receipt of documentation from Adelphia whether any additional information is required. BellSouth will use its best efforts to provide Adelphia written confirmation within three (3) business days of establishing the Master Account that such account has been opened. BellSouth shall also provide Adelphia a tax exemption certificate, if applicable.
- 1.3 Payment Responsibility. Payment of all undisputed charges will be the responsibility of the billed Party. The billed Party shall make payment to the billing Party for all services billed where the charges for such services are undisputed. The billing Party is not responsible for payments not received by the billed Party from the billed Party’s customer. The Billing Party will not become involved in billing disputes that may arise between the billed Party and its customer. Payments made to the billing Party on account will be credited to an accounts receivable master account and not to an end user's account. For purposes of this Section 1, “undisputed amounts” shall mean amounts charged to the billed Party for which the billed Party has not submitted a good faith billing dispute in writing in accordance with this Attachment 7.
- 1.4 Payment Due. The payment will be due by the next bill date (i.e., same date in the following month as the bill date) and is payable in immediately available funds. Payment is considered to have been made when immediately available funds are received.

If the payment due date falls on a Sunday or on a Holiday which is observed on a Monday, the payment due date shall be the first non-Holiday day following such Sunday or Holiday. If the payment due date falls on a Saturday or on a Holiday which is observed on Tuesday, Wednesday, Thursday, or Friday, the payment due date shall be the last non-Holiday day preceding such Saturday or Holiday. If payment is not received by the payment due date, a late payment penalty, as set forth in Section 1.7, below, shall apply.

- 1.5 Tax Exemption. Upon proof of tax exempt certification from a Party, the total amount billed to that Party will not include those taxes or fees for which the Party is exempt. Each Party will be solely responsible for the computation, tracking, reporting and payment of all taxes and like fees associated with the services provided to its end users.
- 1.6 Late Payment. If any portion of the payment is received by the billing Party after the payment due date as set forth preceding, or if any portion of the payment is received by the billing Party in funds that are not immediately available to the billing Party, then a late payment penalty shall be due to the billing Party. The late payment penalty shall be the portion of the undisputed payment not received by the payment due date times a late factor and will be applied on a per bill basis. The late factor for BellSouth shall be as set forth in Section A2 of the General Subscriber Services Tariff, Section B2 of the Private Line Service Tariff or Section E2 of the Intrastate Access Tariff, depending on the service provided. Adelphia will be charged a fee for all returned checks as set forth in Section A2 of the General Subscriber Services Tariff or in applicable state law. The late factor for Adelphia shall be as set forth in Adelphia's effective intrastate access tariff as filed with the Commission.
- 1.7 Discontinuing Service to Adelphia. The procedures for discontinuing service to Adelphia are as follows:
- 1.7.1 BellSouth reserves the right to suspend or terminate service upon seven (7) days written notice in the event of prohibited, unlawful or improper use of the facilities or service, abuse of the facilities, or any other violation or noncompliance by Adelphia of the rules and regulations of BellSouth's Tariffs. If Adelphia should cure the alleged violation within the applicable notice time frame, BellSouth shall not suspend or terminate service.
- 1.7.2 BellSouth reserves the right to refuse additional application for service or to suspend or terminate service if payment of undisputed amounts is not received by the bill day in the month after the original bill day. If BellSouth exercises its right to refuse additional applications pursuant to this Section, BellSouth will provide prior written notice to Adelphia that additional applications for service will be refused and that any pending orders for service will not be completed if payment of undisputed amounts is not received by the fifteenth day following the date of the notice. If BellSouth exercises its right to suspend or terminate service, BellSouth will give thirty (30) days prior written notice to the person designated by Adelphia to receive notices of noncompliance, and discontinue the provision of existing services to Adelphia if Adelphia does not cure within the thirty (30) day timeframe. BellSouth may exercise its rights under this Section separately or simultaneously. For purposes of this Section 1.7, "undisputed amounts" shall mean amounts charged to Adelphia for which Adelphia has not submitted a good faith billing dispute in writing in accordance with this Attachment 7.

- 1.7.3 In the case of such discontinuance, all billed charges, as well as applicable termination charges, shall become due.
- 1.7.4 If BellSouth does not discontinue the provision of the services involved on the date specified in the thirty days notice and Adelphia's noncompliance continues, nothing contained herein shall preclude BellSouth's right to discontinue the provision of the services to Adelphia without further notice.
- 1.7.5 If payment of undisputed amounts is not received or satisfactory arrangements made for payment by the date given in the written notification, Adelphia's services will be discontinued. Upon discontinuance of service on Adelphia's account, service to Adelphia's end users will be denied. BellSouth will reestablish service at the request of the end user or Adelphia for BellSouth to reestablish service upon payment of the appropriate connection fee and subject to BellSouth's normal application procedures. Adelphia is solely responsible for notifying the end user of the proposed service disconnection. If within fifteen (15) days after an end user's service has been denied and no arrangements to reestablish service have been made consistent with this subsection, the end user's service will be disconnected.
- 1.8 Deposit Policy. When purchasing services from BellSouth, if it has not already done so, Adelphia will be required to complete the BellSouth Credit Profile and provide information regarding credit worthiness. Based on the results of the credit analysis, the Company reserves the right to secure the account with a suitable form of security deposit, which shall not exceed two months' estimated billings. Such security deposit shall take the form of cash, an Irrevocable Letter of Credit (BellSouth form), Surety Bond (BellSouth form) or, in its sole discretion, some other form of security. Any such security deposit shall in no way release Adelphia from his obligation to make complete and timely payments of his bill. Such security shall be required prior to the inauguration of service. If, in the sole opinion of BellSouth, gross monthly billing has increased beyond the level initially used to determine the level of security, or there is a material change in Adelphia's financial circumstances BellSouth reserves the right to request additional security and/or file a Uniform Commercial Code (UCC1) security interest in Adelphia's "accounts receivables and proceeds." Interest on a security deposit, if provided in cash, shall accrue and be paid in accordance with the terms in the appropriate BellSouth tariff.
- 1.9 Rates. Rates for Optional Daily Usage File (ODUF), Enhanced Optional Daily Usage File (EODUF), Access Daily Usage File (ADUF), and Centralized Message Distribution Service (CMDS) are set out in Exhibit A to this Attachment. If no rate is identified in this Attachment, the rate for the specific service or function will be as set forth in applicable BellSouth tariff or as negotiated by the Parties upon request by either Party.
- 2. Optional Billing Quality Assurance Program**

- 2.1 Upon request, BellSouth and Adelphia will agree upon a billing quality assurance program for all billing elements covered in this Agreement that will eliminate the need for post-billing reconciliation. Appropriate terms for access to any BellSouth documents, systems, records, and procedures for the recording and billing of charges will be part of that program.
- 2.2 As part of the billing quality assurance program, BellSouth and Adelphia will develop standards, measurements, and performance requirements for a local billing measurements process. On a regular basis BellSouth will provide Adelphia with mutually agreed upon performance measurement data that substantiates the accuracy, reliability, and integrity of the billing process for local billing. In return, Adelphia will pay all bills received from BellSouth in full by the payment due date.
- 2.3 Discrepancies over billing for local services will be addressed in an orderly manner via a mutually agreed upon billing exemption process.
 - 2.3.1 Each Party agrees to notify in writing the other Party upon identifying a billing discrepancy. The Parties shall endeavor to resolve any billing discrepancy within sixty (60) calendar days of the notification date. A mutually agreed upon escalation process will be established for resolving local billing discrepancies as part of the billing quality assurance program.
 - 2.3.2 Closure of a specific billing period will occur by joint agreement of the Parties whereby the Parties agree that such billing period is closed to any further analysis and financial transactions except those resulting from regulatory mandates. Closure will take place within a mutually agreed upon time interval from the bill date. The month being closed represents those charges that were billed or should have been billed by the designated bill date.

3. Billing Disputes

- 3.1 Where the Parties have not agreed upon a billing quality assurance program, billing disputes shall be handled pursuant to the terms of this section.
- 3.2 Each Party agrees to notify the other Party in writing upon the discovery of a billing dispute. In the event of a billing dispute, the Parties will endeavor to resolve the dispute within sixty (60) calendar days of the notification date.
- 3.3 If the Parties are unable to resolve the issues relating to the dispute in the normal course of business within 60 days after delivery of notice of the dispute, each of the Parties shall appoint a designated representative who has authority to settle the dispute and who is at a higher level of management than the persons with direct responsibility for administration of this Agreement. The designated representatives shall meet as

- often as they reasonably deem necessary in order to discuss the dispute and negotiate in good faith in an effort to resolve such dispute.
- 3.4 If the Parties are unable to resolve issues related to the dispute within thirty (30) days after the Parties' appointment of designated representatives pursuant to Section 3.4, then either Party may file a complaint with the Commission to resolve such issues or proceed with any other remedy pursuant to law or equity.
- 3.5 Each Party reserves any rights it may have to seek judicial review of any ruling by the Commission concerning this Agreement.
- 3.6 If a Party disputes a charge and does not pay such charge by the payment due date, or if a payment or any portion of a payment is received by either Party after the payment due date, or if a payment or any portion of a payment is received in funds which are not immediately available to the other Party, then a late payment penalty shall be assessed. In the event the billing dispute is ultimately resolved in favor of the disputing party, that Party shall not be liable for any of the disputed charges or any of the associated late payments. If the dispute is resolved against the disputing Party, the Party shall pay all disputed charges and all associated late payment charges no later than the second bill date after the resolution of the dispute. For bills rendered by either Party for payment, the late payment charge for both Parties shall be calculated based on the portion of the payment not received by the payment due date times the late factor as set forth in the following BellSouth tariffs: for services purchased from the General Subscribers Services Tariff for purposes of resale and for ports and non-designed loops, Section A2 of the General Subscriber Services Tariff; for services purchased from the Private Line Tariff for purposes of resale, Section B2 of the Private Line Service Tariff; and for network elements and other services and local interconnection charges, Section E2 of the Access Service Tariff. In no event, however, shall interest be assessed by either Party on any previously assessed late payment charges. The Parties shall assess interest on previously assessed late payment charges only in a state where it has the authority pursuant to its tariffs.
- 4. Revenue Accounting Office Hosting**
- This section shall apply only to the extent that Adelphia selects BellSouth as its RAO host.
- 4.1 RAO Hosting, Calling Card and Third Number Settlement System (CATS) and Non-Intercompany Settlement System (NICS) services provided to Adelphia by BellSouth will be in accordance with the methods and practices regularly adopted and applied by BellSouth to its own operations during the term of this Agreement, including such revisions as may be made from time to time by BellSouth.
- 4.2 Adelphia shall furnish all relevant information required by BellSouth for the provision of RAO Hosting, CATS and NICS.

- 4.3 Compensation amounts, if applicable, will be billed by BellSouth to Adelphia on a monthly basis in arrears. Amounts due from one Party to the other (excluding adjustments) are payable within thirty (30) days of receipt of the billing statement.
- 4.4 Adelphia must have its own unique hosted RAO code. Requests for establishment of RAO status where BellSouth is the selected Centralized Message Distribution System (CMDS) interfacing host, require written notification from Adelphia to the BellSouth RAO Hosting coordinator at least eight (8) weeks prior to the proposed effective date. The proposed effective date will be mutually agreed upon between the Parties with consideration given to time necessary for the completion of required Telcordia (formerly BellCore) functions. BellSouth will request the assignment of an RAO code from its connecting contractor, currently Telcordia (formerly BellCore), on behalf of Adelphia and will coordinate all associated conversion activities.
- 4.5 BellSouth will receive messages from Adelphia that are to be processed by BellSouth, another LEC or CLEC in the BellSouth region or a LEC outside the BellSouth region.
- 4.6 BellSouth will perform invoice sequence checking, standard EMI format editing, and balancing of message data with the EMI trailer record counts on all data received from Adelphia.
- 4.7 All data received from Adelphia that is to be processed or billed by another LEC or CLEC within the BellSouth region will be distributed to that LEC or CLEC in accordance with the Agreement(s) which may be in effect between BellSouth and the involved LEC or CLEC.
- 4.8 All data received from Adelphia that is to be placed on the CMDS network for distribution outside the BellSouth region will be handled in accordance with the agreement(s) which may be in effect between BellSouth and its connecting contractor (currently Telcordia (formerly BellCore)).
- 4.9 BellSouth will receive messages from the CMDS network that are destined to be processed by Adelphia and will forward them to Adelphia on a daily basis.
- 4.10 Transmission of message data between BellSouth and Adelphia will be via CONNECT:Direct.
- 4.11 All messages and related data exchanged between BellSouth and Adelphia will be formatted in accordance with accepted industry standards for EMI formatted records and packed between appropriate EMI header and trailer records, also in accordance with accepted industry standards.

- 4.12 Adelphia will ensure that the recorded message detail necessary to recreate files provided to BellSouth will be maintained for back-up purposes for a period of three (3) calendar months beyond the related message dates.
- 4.13 Should it become necessary for Adelphia to send data to BellSouth more than sixty (60) days past the message date(s), Adelphia will notify BellSouth in advance of the transmission of the data. If there will be impacts outside the BellSouth region, BellSouth will work with its connecting contractor and Adelphia to notify all affected Parties.
- 4.14 In the event that data to be exchanged between the two Parties should become lost or destroyed, both Parties will work together to determine the source of the problem. Once the cause of the problem has been jointly determined and the responsible Party (BellSouth or Adelphia) identified and agreed to, the company responsible for creating the data (BellSouth or Adelphia) will make every effort to have the affected data restored and retransmitted. If the data cannot be retrieved, the responsible Party will be liable to the other Party for any resulting lost revenue. Lost revenue may be a combination of revenues that could not be billed to the end users and associated access revenues. Both Parties will work together to estimate the revenue amount based upon historical data through a method mutually agreed upon. The resulting estimated revenue loss will be paid by the responsible Party to the other Party within three (3) calendar months of the date of problem resolution, or as mutually agreed upon by the Parties.
- 4.15 Should an error be detected by the EMI format edits performed by BellSouth on data received from Adelphia, the entire pack containing the affected data will not be processed by BellSouth. BellSouth will notify Adelphia of the error condition. Adelphia will correct the error(s) and will resend the entire pack to BellSouth for processing. In the event that an out-of-sequence condition occurs on subsequent packs, Adelphia will resend these packs to BellSouth after the pack containing the error has been successfully reprocessed by BellSouth.
- 4.16 In association with message distribution service, BellSouth will provide Adelphia with associated intercompany settlements reports (CATS and NICS) as appropriate.
- 4.17 In no case shall either Party be liable to the other for any direct or consequential damages incurred as a result of the obligations set out in this Agreement.
- 4.18 RAO Compensation
- 4.18.1 Rates for message distribution service provided by BellSouth for Adelphia are as set forth in Exhibit A to this Attachment.
- 4.18.2 Rates for data transmission associated with message distribution service are as set forth in Exhibit A to this Attachment .

- 4.18.3 Data circuits (private line or dial-up) will be required between BellSouth and Adelphia for the purpose of data transmission. Where a dedicated line is required, Adelphia will be responsible for ordering the circuit, overseeing its installation and coordinating the installation with BellSouth. Adelphia will also be responsible for any charges associated with this line. Equipment required on the BellSouth end to attach the line to the mainframe computer and to transmit successfully ongoing will be negotiated on a case by case basis. Where a dial-up facility is required, dial circuits will be installed in the BellSouth data center by BellSouth and the associated charges assessed to Adelphia. Additionally, all message toll charges associated with the use of the dial circuit by Adelphia will be the responsibility of Adelphia. Associated equipment on the BellSouth end, including a modem, will be negotiated on a case by case basis between the Parties.
- 4.18.4 All equipment, including modems and software, that is required on Adelphia's end for the purpose of data transmission will be the responsibility of Adelphia.
- 4.19 Intercompany Settlements Messages
- 4.19.1 This Section addresses the settlement of revenues associated with traffic originated from or billed by Adelphia as a facilities based provider of local exchange telecommunications services outside the BellSouth region. Only traffic that originates in one Bell operating territory and bills in another Bell operating territory is included. Traffic that originates and bills within the same Bell operating territory will be settled on a local basis between Adelphia and the involved company(ies), unless that company is participating in NICS.
- 4.19.2 Both traffic that originates outside the BellSouth region by Adelphia and is billed within the BellSouth region, and traffic that originates within the BellSouth region and is billed outside the BellSouth region by Adelphia, is covered by this Agreement (CATS). Also covered is traffic that either is originated by or billed by Adelphia, involves a company other than Adelphia, qualifies for inclusion in the CATS settlement, and is not originated or billed within the BellSouth region (NICS).
- 4.19.3 Once Adelphia is operating within the BellSouth territory, revenues associated with calls originated and billed within the BellSouth region will be settled via Telcordia (formerly BellCore)'s, its successor or assign, NICS system.
- 4.19.4 BellSouth will receive the monthly NICS reports from Telcordia (formerly BellCore), its successor or assign, on behalf of Adelphia. BellSouth will distribute copies of these reports to Adelphia on a monthly basis.
- 4.19.5 BellSouth will receive the monthly Calling Card and Third Number Settlement System (CATS) reports from Telcordia (formerly BellCore), its successor or assign, on behalf

of Adelphia. BellSouth will distribute copies of these reports to Adelphia on a monthly basis.

- 4.19.6 BellSouth will collect the revenue earned by Adelphia from the Bell operating company in whose territory the messages are billed (CATS), less a per message billing and collection fee of five cents (\$0.05), on behalf of Adelphia. BellSouth will remit the revenue billed by Adelphia to the Bell operating company in whose territory the messages originated, less a per message billing and collection fee of five cents (\$0.05), on behalf on Adelphia. These two amounts will be netted together by BellSouth and the resulting charge or credit issued to Adelphia via a monthly Carrier Access Billing System (CABS) miscellaneous bill.
- 4.19.7 BellSouth will collect the revenue earned by Adelphia within the BellSouth territory from another CLEC also within the BellSouth territory (NICS) where the messages are billed, less a per message billing and collection fee of five cents (\$0.05), on behalf of Adelphia. BellSouth will remit the revenue billed by Adelphia within the BellSouth region to the CLEC also within the BellSouth region, where the messages originated, less a per message billing and collection fee of five cents (\$0.05). These two amounts will be netted together by BellSouth and the resulting charge or credit issued to Adelphia via a monthly Carrier Access Billing System (CABS) miscellaneous bill.

BellSouth and Adelphia agree that monthly netted amounts of less than fifty dollars (\$50.00) will not be settled.

5. Optional Daily Usage File

- 5.1 Upon written request from Adelphia, BellSouth will provide the Optional Daily Usage File (ODUF) service to Adelphia pursuant to the terms and conditions set forth in this section.
- 5.2 Adelphia shall furnish all relevant information required by BellSouth for the provision of ODUF.
- 5.3 ODUF will contain billable messages that were carried over the BellSouth Network and processed in the BellSouth Billing System, but billed to a Adelphia customer.
- Charges for delivery of ODUF will appear on Adelphia's monthly bills. The charges are as set forth in Exhibit A to this Attachment.
- 5.4 ODUF will contain both rated and unrated messages. All messages will be in the standard Alliance for Telecommunications Industry Solutions (ATIS) EMI record format.

5.5 Messages that error in the billing system of Adelphia will be the responsibility of Adelphia. If, however, Adelphia should encounter significant volumes of errored messages that prevent processing by Adelphia within its systems, BellSouth will work with Adelphia to determine the source of the errors and the appropriate resolution.

5.6 The following specifications shall apply to ODUF.

5.6.1 Usage To Be Transmitted

5.6.1.1 The following messages recorded by BellSouth will be transmitted to Adelphia:

- Message recording for per use/per activation type services (examples: Three Way Calling, Verify, Interrupt, Call Return, ETC.)
- Measured billable Local
- Directory Assistance messages
- IntraLATA Toll
- WATS & 800 Service

- N11
- Information Service Provider Messages
- Operator Services Messages
- Operator Services Message Attempted Calls (Network Element only)
- Credit/Cancel Records
- Usage for Voice Mail Message Service

5.6.1.2 Rated Incollets (originated in BellSouth and from other companies) can also be on ODUF. Rated Incollets will be intermingled with BellSouth recorded rated and unrated usage. Rated Incollets will not be packed separately.

5.6.1.3 BellSouth will perform duplicate record checks on records processed to ODUF. Any duplicate messages detected will be deleted and not sent to Adelphia.

5.6.1.4 In the event that Adelphia detects a duplicate on ODUF they receive from BellSouth, Adelphia will drop the duplicate message (Adelphia will not return the duplicate to BellSouth).

5.6.2 Physical File Characteristics

5.6.2.1 The ODUF will be distributed to Adelphia via an agreed medium with CONNECT:Direct being the preferred transport method. The Daily Usage File will be a variable block format (2476) with an LRECL of 2472. The data on the Daily Usage File will be in a non-compacted EMI format (175 byte format plus modules). It will be created on a daily basis (Monday through Friday except holidays). Details such as dataset name and delivery schedule will be addressed during negotiations of the distribution medium. There will be a maximum of one dataset per workday per OCN.

5.6.2.2 Data circuits (private line or dial-up) may be required between BellSouth and Adelphia for the purpose of data transmission. Where a dedicated line is required, Adelphia will be responsible for ordering the circuit, overseeing its installation and coordinating the installation with BellSouth. Adelphia will also be responsible for any charges associated with this line. Equipment required on the BellSouth end to attach the line to the mainframe computer and to transmit successfully ongoing will be negotiated on a case by case basis. Where a dial-up facility is required, dial circuits will be installed in the BellSouth data center by BellSouth and the associated charges assessed to Adelphia. Additionally, all message toll charges associated with the use of the dial circuit by Adelphia will be the responsibility of Adelphia. Associated equipment on the BellSouth end, including a modem, will be negotiated on a case by case basis between the Parties. All equipment, including modems and software, that is required on Adelphia end for the purpose of data transmission will be the responsibility of Adelphia.

5.6.3 Packing Specifications

5.6.3.1 A pack will contain a minimum of one message record or a maximum of 99,999 message records plus a pack header record and a pack trailer record. One transmission can contain a maximum of 99 packs and a minimum of one pack.

5.6.3.2 The OCN, From RAO, and Invoice Number will control the invoice sequencing. The From RAO will be used to identify to Adelphia which BellSouth RAO that is sending the message. BellSouth and Adelphia will use the invoice sequencing to control data exchange. BellSouth will be notified of sequence failures identified by Adelphia and resend the data as appropriate.

The data will be packed using ATIS EMI records.

5.6.4 Pack Rejection

5.6.4.1 Adelphia will notify BellSouth within one business day of rejected packs (via the mutually agreed medium). Packs could be rejected because of pack sequencing discrepancies or a critical edit failure on the Pack Header or Pack Trailer records (i.e. out-of-balance condition on grand totals, invalid data populated). Standard ATIS EMI Error Codes will be used. Adelphia will not be required to return the actual rejected data to BellSouth. Rejected packs will be corrected and retransmitted to Adelphia by BellSouth.

5.6.5 Control Data

Adelphia will send one confirmation record per pack that is received from BellSouth. This confirmation record will indicate Adelphia received the pack and the acceptance or rejection of the pack. Pack Status Code(s) will be populated using standard ATIS

EMI error codes for packs that were rejected by Adelphia for reasons stated in the above section.

5.6.6 Testing

5.6.6.1 Upon request from Adelphia, BellSouth shall send test files to Adelphia for ODUF. The Parties agree to review and discuss the file's content and/or format. For testing of usage results, BellSouth shall request that Adelphia set up a production (LIVE) file. The live test may consist of Adelphia's employees making test calls for the types of services Adelphia requests on the Optional Daily Usage File. These test calls are logged by Adelphia, and the logs are provided to BellSouth. These logs will be used to verify the files. Testing will be completed within 30 calendar days from the date on which the initial test file was sent.

6. Access Daily Usage File

6.1. Upon written request from Adelphia, BellSouth will provide the Access Daily Usage File (ADUF) service to Adelphia pursuant to the terms and conditions set forth in this section.

6.2 Adelphia shall furnish all relevant information required by BellSouth for the provision of ADUF.

6.3 The ADUF will contain access messages associated with a port that Adelphia has purchased from BellSouth

6.4 Charges for delivery of ADUF will appear on Adelphia's monthly bills. The charges are as set forth in Exhibit A to this Attachment. All messages will be in the standard Alliance for Telecommunications Industry Solutions (ATIS) EMI record format.

6.5 Messages that error in the billing system of Adelphia will be the responsibility of Adelphia. If, however, Adelphia should encounter significant volumes of errored messages that prevent processing by Adelphia within its systems, BellSouth will work with Adelphia to determine the source of the errors and the appropriate resolution.

6.6 Usage To Be Transmitted

6.6.1 The following messages recorded by BellSouth will be transmitted to Adelphia:

Originating and terminating interstate and intrastate access records associated with a port.

Terminating access records for undetermined jurisdiction access records associated with a port.

6.6.2 When Adelphia purchases Network Element ports from BellSouth and calls are made using these ports, BellSouth will handle the calls as follows:

Originating from Network Element and carried by Interexchange Carrier:

BellSouth will bill network element to CLEC and send access record to the CLEC via ADUF

Originating from network element and carried by BellSouth (Adelphia is BellSouth's toll customer):

BellSouth will bill resale toll rates to Adelphia and send toll record for the end user toll billing purposes via ODUF. Access record will be sent to Adelphia via ADUF.

Terminating on network element and carried by Interexchange Carrier:

BellSouth will bill network element to Adelphia and send access record to Adelphia.

Terminating on network element and carried by BellSouth:

BellSouth will bill network element to Adelphia and send access record to Adelphia.

6.6.3 BellSouth will perform duplicate record checks on records processed to ADUF. Any duplicate messages detected will be dropped and not sent to Adelphia.

6.6.4 In the event that Adelphia detects a duplicate on ADUF they receive from BellSouth, Adelphia will drop the duplicate message (Adelphia will not return the duplicate to BellSouth.)

6.6.5 Physical File Characteristics

6.6.5.1 The ADUF will be distributed to Adelphia via an agreed medium with CONNECT:Direct being the preferred transport method. The Daily Usage File will be a fixed block format (2476) with an LRECL of 2472. The data on the Daily Usage File will be in a non-compacted EMI format (210 byte format plus modules). It will be created on a daily basis (Monday through Friday except holidays). Details such as dataset name and delivery schedule will be addressed during negotiations of the distribution medium. There will be a maximum of one dataset per workday per OCN.

6.6.5.2 Data circuits (private line or dial-up) may be required between BellSouth and Adelphia for the purpose of data transmission. Where a dedicated line is required, Adelphia will be responsible for ordering the circuit, overseeing its installation and coordinating the installation with BellSouth. Adelphia will also be responsible for any charges associated with this line. Equipment required on the BellSouth end to attach the line to

the mainframe computer and to transmit successfully ongoing will be negotiated on a case by case basis. Where a dial-up facility is required, dial circuits will be installed in the BellSouth data center by BellSouth and the associated charges assessed to Adelphia. Additionally, all message toll charges associated with the use of the dial circuit by Adelphia will be the responsibility of Adelphia. Associated equipment on the BellSouth end, including a modem, will be negotiated on a case by case basis between the Parties. All equipment, including modems and software, that is required on Adelphia end for the purpose of data transmission will be the responsibility of Adelphia.

6.6.6 Packing Specifications

- 6.6.6.1 A pack will contain a minimum of one message record or a maximum of 99,999 message records plus a pack header record and a pack trailer record. One transmission can contain a maximum of 99 packs and a minimum of one pack.
- 6.6.6.2 The OCN, From RAO, and Invoice Number will control the invoice sequencing. The From RAO will be used to identify to Adelphia which BellSouth RAO that is sending the message. BellSouth and Adelphia will use the invoice sequencing to control data exchange. BellSouth will be notified of sequence failures identified by Adelphia and resend the data as appropriate.

The data will be packed using ATIS EMI records.

6.6.7 Pack Rejection

- 6.6.7.1 Adelphia will notify BellSouth within one business day of rejected packs (via the mutually agreed medium). Packs could be rejected because of pack sequencing discrepancies or a critical edit failure on the Pack Header or Pack Trailer records (i.e. out-of-balance condition on grand totals, invalid data populated). Standard ATIS EMI Error Codes will be used. Adelphia will not be required to return the actual rejected data to BellSouth. Rejected packs will be corrected and retransmitted to Adelphia by BellSouth.

6.6.8 Control Data

Adelphia will send one confirmation record per pack that is received from BellSouth. This confirmation record will indicate Adelphia received the pack and the acceptance or rejection of the pack. Pack Status Code(s) will be populated using standard ATIS EMI error codes for packs that were rejected by Adelphia for reasons stated in the above section.

6.6.9 Testing

- 6.6.9.1 Upon request from Adelphia, BellSouth shall send test files to Adelphia for the ADUF. Testing shall consist of actual calls made from live accounts. A call log shall be supplied along with test request information. The Parties agree to review and discuss the file's content and/or format.

7. Enhanced Optional Daily Usage File

- 7.1 Upon written request from Adelphia, BellSouth will provide the Enhanced Optional Daily Usage File (EODUF) service to Adelphia pursuant to the terms and conditions set forth in this section. EODUF will only be sent to existing ODUF subscribers who request the EODUF option.
- 7.2 Adelphia shall furnish all relevant information required by BellSouth for the provision of EODUF.
- 7.3 The EODUF will provide usage data for local calls originating from resold Flat Rate Business and Residential Lines.

Charges for delivery of the EODUF will appear on Adelphia's monthly bills. The charges are as set forth in Exhibit A to this Attachment.

- 7.4 All messages will be in the standard Alliance for Telecommunications Industry Solutions (ATIS) EMI record format.
- 7.5 Messages that error in the billing system of Adelphia will be the responsibility of Adelphia. If, however, Adelphia should encounter significant volumes of errored messages that prevent processing by Adelphia within its systems, BellSouth will work with Adelphia to determine the source of the errors and the appropriate resolution.
- 7.6 The following specifications shall apply to the Optional Daily Usage File.

7.6.1 Usage To Be Transmitted

- 7.6.1.1 The following messages recorded by BellSouth will be transmitted to the Adelphia:

Customer usage data for flat rated local call originating from CLEC end user lines (1FB or 1FR). The EODUF record for flat rate messages will include:

- Date of Call
- From Number
- To Number
- Connect Time
- Conversation Time

Method of Recording
From RAO
Rate Class
Message Type
Billing Indicators
Bill to Number

7.6.1.2 BellSouth will perform duplicate record checks on EODUF records processed to ODUF. Any duplicate messages detected will be deleted and not sent to Adelphia.

7.6.1.3 In the event that Adelphia detects a duplicate on EODUF they receive from BellSouth, Adelphia will drop the duplicate message (Adelphia will not return the duplicate to BellSouth).

7.6.2 Physical File Characteristics

7.6.2.1 The EODUF will be distributed to Adelphia over their existing ODUF File. The EODUF messages will be intermingled among Adelphia's ODUF messages. The EODUF will be a variable block format (2476) with an LRECL of 2472. The data on the EODUF will be in a non-compacted EMI format (175 byte format plus modules). It will be created on a daily basis (Monday through Friday except holidays).

7.6.2.2 Data circuits (private line or dial-up) may be required between BellSouth and Adelphia for the purpose of data transmission. Where a dedicated line is required, Adelphia will be responsible for ordering the circuit, overseeing its installation and coordinating the installation with BellSouth. Adelphia will also be responsible for any charges associated with this line. Equipment required on the BellSouth end to attach the line to the mainframe computer and to transmit successfully ongoing will be negotiated on a case by case basis. Where a dial-up facility is required, dial circuits will be installed in the BellSouth data center by BellSouth and the associated charges assessed to Adelphia. Additionally, all message toll charges associated with the use of the dial circuit by Adelphia will be the responsibility of Adelphia. Associated equipment on the BellSouth end, including a modem, will be negotiated on a case by case basis between the Parties. All equipment, including modems and software, that is required on Adelphia end for the purpose of data transmission will be the responsibility of Adelphia.

7.6.3 Packing Specifications

7.6.3.1 A pack will contain a minimum of one message record or a maximum of 99,999 message records plus a pack header record and a pack trailer record. One transmission can contain a maximum of 99 packs and a minimum of one pack.

7.6.3.2 The Operating Company Number (OCN), From Revenue Accounting Office (RAO), and Invoice Number will control the invoice sequencing. The From RAO will be used

to identify to Adelphia which BellSouth RAO that is sending the message. BellSouth and Adelphia will use the invoice sequencing to control data exchange. BellSouth will be notified of sequence failures identified by Adelphia and resend the data as appropriate.

The data will be packed using ATIS EMI records.

BELLSOUTH/ADELPHIA RATES
 ODUF/EODUF/ADUF/CMDS

| DESCRIPTION | USOC | KY |
|--|------|-------------|
| ODUF/EODUF/ADUF/CMDS | | |
| ODUF: Recording, per message | N/A | \$0.0008611 |
| ODUF: Message Processing, per message | N/A | \$0.0032357 |
| EODUF: Message Processing, per message | N/A | \$0.004 |
| ADUF: Message Processing, per message | N/A | \$0.004 |
| CMDS: Message Processing, per message | N/A | \$0.004 |
| ODUF: Message Processing, per magnetic tape provisioned | N/A | \$55.68 |
| EODUF: Message Processing, per magnetic tape provisioned | N/A | \$47.30 |
| ODUF: Data Transmission (CONNECT:DIRECT), per message | N/A | \$0.0000365 |
| EODUF: Data Transmission (CONNECT:DIRECT), per message | N/A | \$0.0000364 |
| ADUF: Data Transmission (CONNECT:DIRECT), per message | N/A | \$0.001 |
| CMDS: Data Transmission (CONNECT:DIRECT), per message | N/A | \$0.001 |

NOTES:

If no rate is identified in the contract, the rate for the specific service or function will be as set forth in applicable BellSouth tariff or as negotiated by the parties upon request by either party.

Attachment 8

Rights-of-Way, Conduits and Pole Attachments

Rights-of-Way, Conduits and Pole Attachments

BellSouth will provide nondiscriminatory access to any pole, duct, conduit, or right-of-way owned or controlled by BellSouth pursuant to 47 U.S.C. § 224, as amended by the Act, pursuant to terms and conditions of a license agreement subsequently negotiated with BellSouth's Competitive Structure Provisioning Center.

Attachment 9
Performance Measurements

TABLE OF CONTENTS

Service Performance Measurements And Enforcement Mechanisms..... 3

1. Scope 3

2. Reporting 3

3. Modifications to Measurements..... 3

4. Enforcement Mechanisms..... 4

EXHIBIT A 10

EXHIBIT B..... 78

EXHIBIT C 84

EXHIBIT D100

EXHIBIT E.....106

Service Performance Measurements And Enforcement Mechanisms

1. Scope

This Attachment includes Enforcement Measurements with corresponding Enforcement Mechanisms applicable to this Agreement.

2. Reporting

2.1 In providing services pursuant to this Agreement, BellSouth will report its performance to Adelphia in accordance with BellSouth's Service Quality Measurements, which are contained in this Attachment as Exhibit A and in accordance with BellSouth's Enforcement Measurements, which are contained in this Attachment as Exhibit B.

2.2 BellSouth will make performance reports available to Adelphia on a monthly basis. The reports will contain information collected in each performance category and will be available to Adelphia through some electronic medium to be determined by BellSouth. BellSouth will also provide electronic access to the raw data underlying the performance measurements. Within thirty (30) days of execution of this Agreement, BellSouth will provide a detailed session of instruction to Adelphia regarding access to the reports and to the raw data as well as the nature of the format of the data provided.

3. Modifications to Measurements

3.1 Service Quality Measurements

3.1.1 BellSouth will update the Service Quality Measurements contained in Exhibit A of this Attachment each calendar quarter. BellSouth will not delete any Service Quality Measurement without prior written consent of Adelphia. Adelphia may provide input to BellSouth regarding any suggested additions, deletions or other modifications to the Service Quality Measurements. BellSouth will provide notice of all changes to the Service Quality Measurements via BellSouth's internet website.

3.1.2 Notwithstanding the foregoing, BellSouth may, from time to time, be ordered by a regulatory or judicial body to modify or amend the Service Quality Measurements. BellSouth will make all such changes to the Service Quality Measurements pursuant to Section 12 of the General Terms and Conditions of this Agreement, incorporated herein by reference.

3.1.3 Notwithstanding any other provision of this Agreement, in the event

a dispute arises regarding the modification or amendment of the Service Quality Measurements, the parties will refer the dispute to the Commission.

3.2 **Enforcement Measurements and Statistical Test**

3.2.1 In order for BellSouth to accurately administer the Enforcement Measurements contained in Exhibit B of this Attachment, the Enforcement Measurements shall be modified or amended only if BellSouth determines such modification or amendment is necessary. However, BellSouth will not delete any Enforcement Measurement without prior written consent of Adelphia. BellSouth will notify Adelphia of any such modification or amendment to the Enforcement Measurements via BellSouth's internet website.

3.2.2 Notwithstanding the foregoing, BellSouth may, from time to time, be ordered by a regulatory or judicial body to modify or amend the Enforcement Measurements and/or Statistical Test. BellSouth will make all such changes to the Enforcement Measurements and/or Statistical Test pursuant to Section 12 of the General Terms and Conditions of this Agreement, incorporated herein by reference.

3.2.3 Notwithstanding any other provision of this Agreement, in the event a dispute arises regarding the modification or amendment of the Enforcement Measurements and/or Statistical Test, the parties will refer the dispute to the Commission.

4. **Enforcement Mechanisms**

4.1 **Purpose**

This section establishes meaningful and significant enforcement mechanisms voluntarily provided by BellSouth to verify and maintain compliance between BellSouth and Adelphia's operations as well as to maintain access to Operational Support System (OSS) functions. This section provides the terms and conditions for such self-effectuating enforcement mechanisms.

4.2 **Effective Date**

The enforcement mechanisms set forth in this section shall only become effective upon an effective FCC order, which has not been stayed, authorizing BellSouth to provide interLATA telecommunications services under section 271 of the Act within a particular state and shall only apply to BellSouth's performance in any state in which the FCC has granted BellSouth interLATA authority.

- 4.3 Definitions
- 4.3.1 Enforcement Measurement Elements means the performance measurements set forth in Exhibit B, attached hereto and incorporated herein by this reference.
- 4.3.2 Enforcement Measurement Benchmark means a competitive level of performance negotiated by BellSouth used to compare the performance of BellSouth and Adelphia where no analogous process, product or service is feasible. See Exhibit B.
- 4.3.3 Enforcement Measurement Compliance means comparing performance levels provided to BellSouth retail customers with performance levels provided by BellSouth to the CLEC customer, as set forth in Exhibit C, attached hereto and incorporated herein by this reference.
- 4.3.4 Test Statistic and Balancing Critical Value is the means by which enforcement will be determine using statistically valid equations. See Exhibit C.
- 4.3.5 Cell is the point (below the wire center level) at which like-to-like comparisons are made. For example, all BellSouth retail POTS services, for residential customers, requiring a dispatch in a particular wire center, at a particular point in time will be compared directly to Adelphia resold services for residential customers, requiring a dispatch, in the same wire center, at a particular point in time. When determining compliance, these cells can have a positive or negative value. See Exhibit C.
- 4.3.6 Affected Volume means that proportion of the total Adelphia volume or CLEC Aggregate volume for which remedies will be paid.
- 4.3.7 Parity Gap refers to the incremental departure from a compliant-level of service. (See Exhibit D). This is also referred to as “diff” in the Statistical paper (See Exhibit C).
- 4.3.8 Tier-1 Enforcement Mechanisms means self-executing liquidated damages paid directly to Adelphia when BellSouth delivers non-compliant performance of any one of the Enforcement Measurement Elements for any month as calculated by BellSouth.
- 4.3.9 Tier-2 Enforcement Mechanisms means Assessments paid directly to a state Public Service Commission (“Commission”) or its designee. Tier 2 Enforcement Mechanisms are triggered by three consecutive monthly failures in a quarter in which BellSouth performance is out of compliance or does not meet the benchmarks for the aggregate of all CLEC data as

calculated by BellSouth for a particular Enforcement Measurement Element.

- 4.3.10 Tier-3 Enforcement Mechanisms means the voluntary suspension of additional marketing and sales of long distance services triggered by excessive repeat failures of those specific submeasures as defined in Exhibit D attached hereto and incorporated herein by this reference.
- 4.4 Application
- 4.4.1 The application of the Tier-1, Tier-2, and Tier-3 Enforcement Mechanisms does not foreclose other non-contractual legal and regulatory claims and remedies available to Adelphia.
- 4.4.2 Proof of damages resulting from BellSouth's failure to maintain Enforcement Measurement Compliance would be difficult to ascertain and, therefore, liquidated damages are a reasonable approximation of any contractual damage. Liquidated damages under this provision are not intended to be a penalty.
- 4.5 Methodology
- 4.5.1 Tier-1 Enforcement Mechanisms will be triggered by BellSouth's failure to achieve Enforcement Measurement Compliance or Enforcement Measurement Benchmarks for the State for a given Enforcement Measurement Element in a given month based upon a test statistic and balancing critical value calculated by BellSouth utilizing BellSouth generated data. The method of calculation is attached hereto as Exhibit D and incorporated herein by this reference.
- 4.5.1.1 Tier-1 Enforcement Mechanisms apply on a per transaction basis for each negative cell and will escalate based upon the number of consecutive months that BellSouth has reported non-compliance.
- 4.5.1.2 Fee Schedule for Tier-1 Enforcement Mechanisms is shown in Table-1 attached hereto as Exhibit E and incorporated herein by this reference. Failures beyond Month 6 (as set forth in Table 1) will be subject to Month 6 fees.
- 4.5.2 Tier-2 Enforcement Mechanisms will be triggered by BellSouth's failure to achieve Enforcement Measurement Compliance or Enforcement Measurement Benchmarks for the State in a given calendar quarter based upon a statistically valid equation calculated by BellSouth utilizing BellSouth generated data. The method of calculation is attached hereto as Exhibit D and incorporated herein by reference.

- 4.5.2.1 Tier- 2 Enforcement Mechanisms apply, for an aggregate of all CLEC data generated by BellSouth, on a per transaction basis for each negative cell for a particular Enforcement Measurement Element.
- 4.5.2.2 Fee Schedule for Total Quarterly Tier-2 Enforcement Mechanisms is show in Table-2 attached hereto as Exhibit E and incorporated herein by this reference.
- 4.5.3 Tier-3 Enforcement Mechanisms will be triggered by BellSouth's failure to achieve Enforcement Measurement Compliance or Enforcement Measurement Benchmarks for a State in a given calendar quarter. The method of calculation for specified submeasures is identical to the method of calculation for Tier-2 Enforcement Mechanisms as described above. The specific submeasures which are the mechanism for triggering and removing a Tier-3 Enforcement Mechanisms are described in more detail in Exhibit D attached hereto and incorporated herein by this reference.
- 4.6 Payment of Tier-1 and Tier-2 Amounts
- 4.6.1 If BellSouth performance triggers an obligation to pay Tier-1 Enforcement Mechanisms to Adelphia or an obligation to remit Tier-2 Enforcement Mechanisms to the Commission, BellSouth shall make payment in the required amount on or before the thirtieth (30th) day following the due date of the performance measurement report for the month in which the obligation arose.
- 4.6.2 For each day after the due date that BellSouth fails to pay Adelphia the required amount, BellSouth will pay interest to Adelphia at the maximum rate permitted by state law.
- 4.6.3 For each day after the due date that BellSouth fails to pay the Tier-2 Enforcement Mechanisms, BellSouth will pay the Commission an additional \$1,000 per day.
- 4.6.4 If Adelphia disputes the amount paid to Adelphia for Tier-1 Enforcement Mechanisms, Adelphia shall submit a written claim to BellSouth within sixty (60) days after the date of the performance measurement report for which the obligation arose. BellSouth shall investigate all claims and provide Adelphia written findings within thirty (30) days after receipt of the claim. If BellSouth determines Adelphia is owed additional amounts, BellSouth shall pay Adelphia such additional amounts within thirty (30) days after its findings along with interest paid at the maximum rate permitted by law.

- 4.6.5 At the end of each calendar year, BellSouth will have its independent auditing and accounting firm certify that the results of all Tier-1 and Tier-2 Enforcement Mechanisms were paid and accounted for in accordance with Generally Accepted Account Principles (GAAP).
- 4.7 Limitations of Liability
- 4.7.1 BellSouth will not be responsible for Adelphia acts or omissions that cause performance measures to be missed or fail, including but not limited to accumulation and submission of orders at unreasonable quantities or times or failure to submit accurate orders or inquiries. BellSouth shall provide Adelphia with reasonable notice of such acts or omissions and provide Adelphia any such supporting documentation.
- 4.7.2 BellSouth shall not be obligated for Tier-1, Tier-2 or Tier 3 Enforcement Mechanisms for non-compliance with a performance measure if such non-compliance was the result of an act or omission by Adelphia that is in bad faith.
- 4.7.3 BellSouth shall not be obligated to pay Tier-1 Enforcement Mechanisms or Tier-2 Enforcement Mechanism for non-compliance with a performance measurement if such non-compliance was the result of any of the following: a Force Majeure event as set forth in the General Terms and Conditions of this Agreement; an act or omission by Adelphia that is contrary to any of its obligations under its Interconnection Agreement with BellSouth; an act or omission by Adelphia that is contrary to any of its obligations under the Act, Commission rule, or state law; an act or omission associated with third-party systems or equipment; or any occurrence that results from an incident reasonably related to the Y2K problem.
- 4.7.4 It is not the intent of the Parties that BellSouth be liable for both Tier-2 Enforcement Mechanisms and any other assessments or sanctions imposed by the Commission. Adelphia will not oppose any effort by BellSouth to set off Tier-2 Enforcement Mechanisms from any additional assessment imposed by the Commission.
- 4.7.5 Payment of any Tier-1 or Tier-2 Enforcement Mechanisms shall not be considered as an admission against interest or an admission of liability or culpability in any legal, regulatory or other proceeding relating to BellSouth's performance. The payment of any Tier-1 Enforcement Mechanisms to Adelphia shall release BellSouth for any liability associated with or related to the service performance measurement for the month for which the Enforcement Mechanisms was paid to Adelphia.

4.7.6 Adelphia acknowledges and argues that the Enforcement Mechanisms contained in this attachment have been provided by BellSouth on a completely voluntary basis in order to maintain compliance between BellSouth and Adelphia. Therefore, Adelphia may not use the existence of this section or any payments of any Tier-1 or Tier-2 Enforcement Mechanisms under this section as evidence that BellSouth has not complied with or has violated any state or federal law or regulation.

4.8 Enforcement Mechanism Caps

4.8.1 BellSouth's liability for the payment of Tier-1 and Tier-2 Enforcement Mechanisms shall be collectively capped at \$625M per year for the entire BellSouth region as set forth below.

| | |
|-------------------------|------------|
| AL - \$54M | MS - \$44M |
| FL - \$122M | NC - \$77M |
| GA - \$131M | SC - \$47M |
| KY - \$34M | TN - \$57M |
| LA - \$59M | |
| Regional Total - \$625M | |

4.8.2 If BellSouth's liability for the payment of Tier-1 and Tier-2 Enforcement Mechanisms exceed the caps referenced in this attachment, Adelphia may commence a proceeding with the Commission to demonstrate why BellSouth should pay any amount in excess of the cap. Adelphia shall have the burden of proof to demonstrate why, under the circumstances, BellSouth should have additional liability.

4.9 Dispute Resolution

4.9.1 Notwithstanding any other provision of this Agreement, any dispute regarding BellSouth's performance or obligations pursuant to this Attachment shall be resolved by the Commission.

EXHIBIT A

ORDERING

| | |
|--|---|
| Report/Measurement: | |
| O-7. Speed of Answer in Ordering Center | |
| Definition: | |
| Measures the average time a customer is in queue. | |
| Exclusions: | |
| None | |
| Business Rules: | |
| The clock starts when the appropriate option is selected (i.e. 1 for Resale Consumer, 2 for Resale Multiline, and 3 for UNE-LNP, etc.) and the call enters the queue for that particular group in the LCSC. The clock stops when a BST service representative in the LCSC answers the call. The speed of answer is determined by measuring and accumulating the elapsed time from the entry of a CLEC call into the BellSouth automatic call distributor (ACD) until the a service representative in BSTs Local Carrier Service Center (LCSC) answers the CLEC call. | |
| Calculation: | |
| $(\text{Total time in seconds to reach the LCSC}) / (\text{Total Number of Calls})$ in the Reporting Period. | |
| Report Structure: | |
| <ul style="list-style-type: none"> • CLEC Aggregate • BST Aggregate (Combination of Residence Service Center and Business Service Center data under development) | |
| Level of Disaggregation: | |
| <ul style="list-style-type: none"> • CLEC Aggregate • BST Aggregate (Combination of Residence Service Center and Business Service Center data under development) | |
| Data Retained Relating to CLEC Experience: | Data Retained Relating to BST Performance: |
| <ul style="list-style-type: none"> • Mechanized tracking through LCSC Automatic Call Distributor | <ul style="list-style-type: none"> • Mechanized tracking through BST Retail center support systems |
| Retail Analog/Benchmark: | |
| For CLEC, Speed of Answer in Ordering Center (LCSC) is comparable to Speed of Answer in BST Business Offices. See Appendix D | |

Revision Date: 02/16/00 (lg)

ORDERING – (LNP)

| |
|---|
| Report/Measurement: |
| LNP-8. Percent Rejected Service Requests |
| Definition: |
| Percent Rejected Service Request is the percent of total Local Service Requests (LSRs) which are rejected due to error or omission. An LSR is considered valid when it is electronically submitted by the CLEC and passes LNP Gateway edit checks to insure the data received is correctly formatted and complete, i.e., fatal rejects are excluded. |
| Exclusions: |
| <ul style="list-style-type: none"> • Service Requests canceled by the CLEC • Fatal Rejects • Order Activities of BST or the CLEC associated with internal or administrative use of local services (Record Orders, Test Orders, etc.) where identifiable. |
| Business Rules: |
| An LSR is considered “rejected” when it is submitted electronically but does not pass edit checks in the ordering systems (EDI, TAG, LNP Gateway, LAUTO) and is returned to the CLEC without manual intervention. |
| Fully Mechanized: There are two types of “Rejects” in the Fully Mechanized category: |
| <ul style="list-style-type: none"> • A Fatal Reject occurs when a CLEC attempts to electronically submit an LSR (via EDI or TAG) but required fields are not populated correctly and the request is returned to the CLEC. Fatal rejects are reported in a separate column, and for informational purposes ONLY. They are not considered in the calculation of the percent of total LSRs rejected or the total number of rejected LSRs. • An Auto Clarification is a valid LSR which is electronically submitted (via EDI or TAG), but is rejected from LAUTO because it does not pass further edit checks for order accuracy. Auto Clarifications are returned without manual intervention. |
| Partially Mechanized: A valid LSR which is electronically submitted (via EDI or TAG), but cannot be processed electronically due to a CLEC error and “falls out” for manual handling. It is then put into “clarification”, and sent back to the CLEC. |
| Total Mechanized: Combination of Fully Mechanized and Partially Mechanized rejects. |
| Calculation |
| Percent Rejected Service Requests: |
| $\left[\frac{\text{(Number of Service Requests Rejected in the Reporting Period)}}{\text{(Number of Service Requests Received in the Reporting Period)}} \right] \times 100$ |
| Report Structure: |
| <ul style="list-style-type: none"> • Fully Mechanized, Partially Mechanized, Total Mechanized • CLEC Specific • CLEC Aggregate |
| Level of Disaggregation: |
| <ul style="list-style-type: none"> • Product Reporting Levels <ul style="list-style-type: none"> ➢ LNP ➢ UNE Loop with LNP • Geographic Scope <ul style="list-style-type: none"> ➢ .State, Region |
| Retail Analog/Benchmark: |
| See Appendix D |

Revision Date: 02/16/00 (lg)

ORDERING – (LNP)

| |
|---|
| Report/Measurement: |
| LNP-9. Reject Interval Distribution & Average Reject Interval |
| Definition: Reject Interval is the average reject time from receipt of an LSR to the distribution of a Reject. An LSR is considered valid when it is electronically submitted by the CLEC and passes LNP Gateway edit checks to insure the data received is correctly formatted and complete, i.e., fatal rejects are excluded. |
| Exclusions: <ul style="list-style-type: none"> • Service Requests canceled by CLEC • Fatal Rejects • Order Activities of BST or the CLEC associated with internal or administrative use of local services (Record Orders, Test Orders, etc.) where identifiable. |
| Business Rules: The Reject interval is determined for each rejected LSR processed during the reporting period. The Reject interval is the elapsed time from when BST receives LSR until that LSR is rejected back to the CLEC. Elapsed time for each LSR is accumulated for each reporting dimension. The accumulated time for each reporting dimension is then divided by the associated total number of rejected LSRs to produce the reject interval distribution. An LSR is considered “rejected” when it is submitted electronically but does not pass edit checks in the ordering systems (EDI, TAG, LNP Gateway, LAUTO) and is returned to the CLEC without manual intervention. Fully Mechanized: There are two types of “Rejects” in the Fully Mechanized category: <ul style="list-style-type: none"> • A Fatal Reject occurs when a CLEC attempts to electronically submit an LSR but required fields are not populated correctly and the request is returned to the CLEC. <i>Fatal rejects are reported in a separate column, and for informational purposes ONLY. They are not considered in the calculation of the percent of total LSRs rejected or the number of rejected LSRs.</i> • An Auto Clarification is a valid LSR which is electronically submitted (via EDI or TAG), but rejected from LAUTO because it does not pass further edit checks for order accuracy. Auto Clarifications are returned without manual intervention. <p>Partially Mechanized: A valid LSR which is electronically submitted (via EDI or TAG), but cannot be processed electronically due to a CLEC error and “falls out” for manual handling. It is then put into “clarification”, and sent back to the CLEC.</p> <p>Total Mechanized: Combination of Fully Mechanized and Partially Mechanized rejects.</p> |
| Calculation: Average Reject Interval: $\frac{\Sigma (\text{Date \& Time of Service Request Rejection}) - (\text{Date \& Time of Service Request Receipt})}{(\text{Total Number of Service Requests Rejected in Reporting Period})}$ Reject Interval Distribution: $[\frac{\Sigma (\text{Service Requests Rejected in “X” minutes/hours})}{(\text{Total Number of Service Requests Rejected in Reporting Period})}] \times 100$ |
| Report Structure: <ul style="list-style-type: none"> • Fully Mechanized, Partially Mechanized, Total Mechanized • CLEC Specific • CLEC Aggregate |

ORDERING – (LNP) - Reject Interval Distribution & Average Reject Interval – Continued

| |
|---|
| Level of Disaggregation: <ul style="list-style-type: none">• Reported in intervals = 0 - 4 minutes, 4 - 8 minutes, 8 - 12 minutes, 12 - 60 minutes, 0 - 1 hours, 1 - 8 hours, 8 - 24 hours, >24 hours• Product Reporting Levels<ul style="list-style-type: none">➤ LNP➤ UNE Loop with LNP• Geographic Scope<ul style="list-style-type: none">➤ .State, Region• Average Interval in Days |
| Retail Analog/Benchmark: |
| See Appendix D |

Revision Date: 02/16/00 (lg)

ORDERING – (LNP)

| |
|--|
| Report/Measurement: |
| LNP-10. Firm Order Confirmation Timeliness Interval Distribution & Firm Order Confirmation Average Interval |
| Definition: |
| Interval for Return of a Firm Order Confirmation (FOC Interval) is the average response time from receipt of a valid LSR to distribution of a firm order confirmation. |
| Exclusions: |
| <ul style="list-style-type: none"> • Rejected LSRs (Clarifications or Fatal Rejects) • Order Activities of BST or the CLEC associated with internal or administrative use of local services (Record Orders, Test Orders, etc.) where identifiable. |
| Business Rules: |
| <p>The Firm Order Confirmation interval is determined for each FOC'd LSR processed during the reporting period. The Firm Order Confirmation interval is the elapsed time from when BST receives an LSR until that LSR is confirmed back to the CLEC. Elapsed time for each LSR is accumulated for each reporting dimension. The accumulated time for each reporting dimension is then divided by the associated total number of orders completed to produce the Firm Order Confirmation timeliness interval distribution.</p> <ul style="list-style-type: none"> • Mechanized - The elapsed time from receipt of a valid LSR until the LSR is processed and appropriate service orders are generated in SOCS without manual intervention. • Partially Mechanized - The elapsed time from receipt of an electronically submitted LSR which falls out for manual handling by the LCSC personnel until appropriate service orders are issued by a BST service representative via Direct Order Entry (DOE) or Service Order Negotiation Generation System (SONGS). • Total Mechanized - Combination of Fully Mechanized and Partially Mechanized FOCs. |
| Calculation: |
| <p>Average FOC Interval: $\Sigma [(Date \& Time \text{ of Firm Order Confirmation}) - (Date \& Time \text{ of Service Request Receipt})] / (\text{Total number of Service Requests Confirmed in the Reporting Period})$</p> <p>FOC Interval Distribution: $\Sigma [(\text{Service Requests Confirmed in "X" minutes/hours in the Reporting Period}) / (\text{Total Service Requests Confirmed in the Reporting Period})] \times 100$</p> |
| Report Structure: |
| <ul style="list-style-type: none"> • Fully Mechanized, Partially Mechanized, Total Mechanized • CLEC Specific • CLEC Aggregate |
| Level of Disaggregation: |
| <ul style="list-style-type: none"> • Reported in intervals = 0 - 15 minutes, 15 - 30 minutes, 30 - 45 minutes, 45 - 60 minutes, 90 - 120 minutes, 120 - 240 minutes, 4 - 8 hours, 8 - 12 hours, 12 - 16 hours, 16 - 20 hours, 20 - 24 hours, 24 - 48 hours, >48 hours • Product Reporting Levels <ul style="list-style-type: none"> ➢ LNP ➢ UNE Loop with LNP • Geographic Scope <ul style="list-style-type: none"> ➢ .State, Region |
| Retail Analog/Benchmark: |
| See Appendix D |

Revision Date: 02/16/00 (lg)

Provisioning Disaggregation

Product Reporting Levels

- Resale and Retail
 - POTS – Residence
 - POTS – Business
 - Design
 - PBX (Louisiana SQM)
 - CENTREX (Louisiana SQM)
 - ISDN (Louisiana SQM) (**NOTE:** ISDN included in POTS for Georgia Only)
 - ESSX (Louisiana SQM)

- Unbundled Network Elements
 - UNE Design
 - UNE Non – Design
 - UNE 2 Wire Loop (Louisiana SQM)
 - UNE Loop Other (Louisiana SQM)
 - Unbundled Ports (Louisiana SQM)

- Trunks
 - Local Interconnection Trunks

- Geographic Scope
 - State, Region and further geographic disaggregation as required by State Commission Order (e.g. Metropolitan Service Area – MSA)

The following measure is the exception for all states:

Coordinated Customer Conversion

Which is disaggregated as follows:

UNE LOOPS with INP

UNE LOOPS without INP

PROVISIONING

| |
|--|
| Report/Measurement: |
| P-1. Mean Held Order Interval & Distribution Intervals |
| Definition: |
| When delays occur in completing CLEC orders, the average period that CLEC orders are held for BST reasons, pending a delayed completion, should be no worse for the CLEC when compared to BST delayed orders. |
| Exclusions: |
| Order Activities of BST associated with internal or administrative use of local services. |
| Business Rules: |
| <p>Mean Held Order Interval: This metric is computed at the close of each report period. The held order interval is established by first identifying all orders, at the close of the reporting interval, that both have not been reported as completed in SOCS and have passed the currently committed due date for the order. For each such order, the number of calendar days between the committed due date and the close of the reporting period is established and represents the held order interval for that particular order. The held order interval is accumulated by the standard groupings, unless otherwise noted, and the reason for the order being held. The total number of days accumulated in a category is then divided by the number of held orders within the same category to produce the mean held order interval. The interval is by calendar days with no exclusions for Holidays or Sundays.</p> <p>CLEC Specific reporting is by type of held order (facilities, equipment, other), total number of orders held, and the total and average days.</p> <p>Held Order Distribution Interval: This measure provides data to report total days held and identifies these in categories of >15 days and > 90 days. (orders counted in >90 days are also included in >15 days).</p> |
| Calculation: |
| <p>Mean Held Order Interval: $\frac{\Sigma(\text{Reporting Period Close Date} - \text{Committed Order Due Date})}{(\text{Number of Orders Pending and Past The Committed Due Date})}$ for all orders pending and past the committed due date.</p> <p>Held Order Distribution Interval: $\frac{(\# \text{ of Orders Held for } \geq 90 \text{ days})}{(\text{Total } \# \text{ of Orders Pending But Not Completed})} \times 100$ $\frac{(\# \text{ of Orders Held for } \geq 15 \text{ days})}{(\text{Total } \# \text{ of Orders Pending But Not Completed})} \times 100$</p> |
| Report Structure: |
| <ul style="list-style-type: none"> • CLEC Specific • CLEC Aggregate • BST Aggregate |
| Level of Disaggregation: |
| Circuit breakout < 10, > = 10 |

PROVISIONING - Mean Held Order Interval & Distribution Intervals – Continued)

| Data Retained Relating to CLEC Experience | Data Retained Relating to BST Experience |
|--|--|
| <ul style="list-style-type: none"> • Report Month • CLEC Order Number and PON (PON) • Order Submission Date (TICKET_ID) • Committed Due Date (DD) • Service Type(CLASS_SVC_DESC) • Hold Reason • Total line/circuit count • Geographic Scope <p>NOTE: Code in parentheses is the corresponding header found in the raw data file.</p> | <ul style="list-style-type: none"> • Report Month • BST Order Number • Order Submission Date • Committed Due Date • Service Type • Hold Reason • Total line/circuit count • Geographic Scope |
| <p>Retail Analog/Benchmark:</p> <ul style="list-style-type: none"> CLEC Residence Resale / BST Residence Retail CLEC Business Resale / BST Business Retail CLEC Non-UNE Design / BST Design Interconnection Trunks-CLEC / Interconnection Trunks –BST UNEs-(See Appendix D) | |

Revision Date: 02/24/00 (taf)

PROVISIONING

| | |
|--|--|
| Report/Measurement: | |
| P-2. Average Jeopardy Notice Interval & Percentage of Orders Given Jeopardy Notices | |
| Definition: | |
| When BST can determine in advance that a committed due date is in jeopardy, it will provide advance notice to the CLEC. | |
| Exclusions: | |
| <ul style="list-style-type: none"> • Orders held for CLEC end user reasons • Orders submitted to BST through non-mechanized methods | |
| Business Rules: | |
| When BST can determine in advance that a committed due date is in jeopardy it will provide advance notice to the CLEC. The number of committed orders in a report period is the number of orders that have a due date in the reporting period. | |
| Calculation: | |
| Average Jeopardy Interval = $\Sigma [(\text{Date and Time of Scheduled Due Date on Service Order}) - (\text{Date and Time of Jeopardy Notice})] / [\text{Number of Orders Notified of Jeopardy in Reporting Period}]$ Percent of Orders Given Jeopardy Notice = $\Sigma [(\text{Number of Orders Given Jeopardy Notices in Reporting Period}) / (\text{Number of Orders Confirmed (due) in Reporting Period})]$ | |
| Report Structure: | |
| <ul style="list-style-type: none"> • CLEC Specific • CLEC Aggregate • BST Aggregate | |
| Data Retained Relating to CLEC Experience | Data Retained Relating to BST Experience |
| <ul style="list-style-type: none"> • Report Month • CLEC Order Number and PON • Date and Time Jeopardy Notice sent • Committed Due Date • Service Type | <ul style="list-style-type: none"> • Report Month • BST Order Number • Date and Time Jeopardy Notice sent • Committed Due Date • Service type |
| NOTE: Code in parentheses is the corresponding header found in the raw data file. | |
| Retail Analog/Benchmark: | |
| 95% > = 24 hours | |

Revision Date: 01/05/00 (taf)

PROVISIONING

| | |
|--|--|
| Report/Measurement: | |
| P-3. Percent Missed Installation Appointments | |
| Definition: | |
| “Percent missed installation appointments” monitors the reliability of BST commitments with respect to committed due dates to assure that CLECs can reliably quote expected due dates to their retail customer as compared to BST. | |
| Exclusions: | |
| <ul style="list-style-type: none"> • Canceled Service Orders • Order Activities of BST or the CLEC associated with internal or administrative use of local services (Record Orders, Test Orders, etc.) • Disconnect (D) & From (F) orders • End User Misses on Interconnection Trunks | |
| Business Rules: | |
| Percent Missed Installation Appointments is the percentage of total orders processed for which BST is unable to complete the service orders on the confirmed due dates. Missed Appointments caused by end-user reasons will be included and reported separately. A business day is any time period within the same date frame, which means there cannot be a cutoff time for commitments as certain types of orders are requested to be worked after standard business hours. Also, during Daylight Savings Time, field technicians are scheduled until 9PM in some areas and the customer is offered a greater range of intervals from which to select. | |
| Calculation: | |
| Percent Missed Installation Appointments = Σ (Number of Orders Not Complete by Committed Due Date in Reporting Period) / (Number of Orders Confirmed in Reporting Period) X 100 | |
| Report Structure: | |
| <ul style="list-style-type: none"> • CLEC Specific • CLEC Aggregate • BST Aggregate <p>Report explanation: The difference between End User MA and Total MA is the result of BST caused misses. Here, Total MA is the total % of orders missed either by BST or CLEC end user. The End User MA represents the percentage of orders missed by the CLEC or their end user.</p> | |
| Level of Disaggregation: | |
| <ul style="list-style-type: none"> • Reported in categories of <10 lines/circuits; > = 10 lines/circuits • Dispatch/No Dispatch | |
| Data Retained Relating to CLEC Experience | Data Retained Relating to BST Experience |
| <ul style="list-style-type: none"> • Report Month • CLEC Order Number and PON (PON) • Committed Due Date (DD) • Completion Date (CMPLTN DD) • Status Type • Status Notice Date • Standard Order Activity • Geographic Scope | <ul style="list-style-type: none"> • Report Month • BST Order Number • Committed Due Date (DD) • Completion Date (CMPLTN DD) • Status Type • Status Notice Date • Standard Order Activity • Geographic Scope |
| NOTE: Code in parentheses is the corresponding header found in the raw data file. | |
| Retail Analog/Benchmark: | |
| CLEC Residence Resale / BST Residence Retail CLEC Business Resale / BST Business Retail CLEC Non-UNE Design / BST Design Interconnection Trunks-CLEC / Interconnection Trunks –BST UNEs-(See Appendix D) | |

Revision Date: 02/28/00 (taf)

PROVISIONING

| |
|---|
| Report/Measurement : |
| P-4. Average Completion Interval (OCI) & Order Completion Interval Distribution |
| Definition: |
| The “average completion interval” measure monitors the interval of time it takes BST to provide service for the CLEC or its’ own customers. The “Order Completion Interval Distribution” provides the percentage of orders completed within certain time periods. |
| Exclusions: |
| <ul style="list-style-type: none"> • Canceled Service Orders • Order Activities of BST or the CLEC associated with internal or administrative use of local services (Record Orders, Test Orders, etc.) • D (Disconnect) and F (From) orders. (From is disconnect side of a move order when the customer moves to a new address). • “L” Appointment coded orders (where the customer has requested a later than offered interval) |
| Business Rules: |
| The actual completion interval is determined for each order processed during the reporting period. The completion interval is the elapsed time from when BST issues a FOC or SOCS date time stamp receipt of an order from the CLEC to BST’s actual order completion date. The clock starts when a valid order number is assigned by SOCS and stops when the technician or system completes the order in SOCS. Elapsed time for each order is accumulated for each reporting dimension. The accumulated time for each reporting dimension is then divided by the associated total number of orders completed. |
| The interval breakout for UNE and Design is: 0-5 = 0-4.99, 5-10 = 5-9.99, 10-15 = 10-14.99, 15-20 = 15-19.99 20-25 = 20-24.99, 25-30 = 25-29.99, >=30 = 30 and greater. |
| Calculation : |
| Average Completion Interval: $\frac{\sum [(Completion\ Date\ \&\ Time) - (Order\ Issue\ Date\ \&\ Time)]}{\sum (Count\ of\ Orders\ Completed\ in\ Reporting\ period)}$ |
| Order Completion Interval Distribution: $\frac{\sum (Service\ Orders\ Completed\ in\ "X"\ days)}{(\sum (Total\ Service\ Orders\ Completed\ in\ Reporting\ Period))} \times 100$ |
| Report Structure: |
| <ul style="list-style-type: none"> • CLEC Specific • CLEC Aggregate • BST Aggregate |
| Level of Disaggregation: |
| <ul style="list-style-type: none"> • ISDN Orders included in Non Design - GA Only • Dispatch/No Dispatch categories applicable to all levels except trunks. • Residence & Business reported in day intervals = 0,1,2,3,4, 5, 5+ • UNE and Design reported in day intervals = 0-5, 5-10, 10-15, 15-20, 20-25, 25-30, >=30 • All Levels are reported <10 line/circuits; >=10 line/circuits |

PROVISIONING –

(Average Completion Interval (OCI) & Order Completion Interval Distribution – Continued)

| Data Retained Relating to CLEC Experience | Data Retained Relating to BST Experience |
|---|--|
| <ul style="list-style-type: none"> • Report Month • CLEC Company Name • Order Number (PON) • Submission Date & Time (TICKET_ID) • Completion Date (CMPLTN_DT) • Service Type (CLASS_SVC_DESC) • Geographic Scope <p>NOTE: Code in parentheses is the corresponding header found in the raw data file.</p> | <ul style="list-style-type: none"> • Report Month • BST Order Number • Order Submission Date & Time • Order Completion Date & Time • Service Type • Geographic Scope |
| <p>Retail Analog/Benchmark</p> <ul style="list-style-type: none"> CLEC Residence Resale / BST Residence Retail CLEC Business Resale / BST Business Retail CLEC Non-UNE Design / BST Design Interconnection Trunks-CLEC / Interconnection Trunks-BST UNEs-(See Appendix D) | |

Revision Date: 02/28/00 (taf)

PROVISIONING

| | |
|---|---|
| Report/Measurement: | |
| P-5. Average Completion Notice Interval | |
| Definition: | |
| The Completion Notice Interval is the elapsed time between the BST reported completion of work and the issuance of a valid completion notice to the CLEC. | |
| Exclusions: | |
| <ul style="list-style-type: none"> • Non-mechanized Orders • Cancelled Service Orders • Order Activities of BST associated with internal or administrative use of local services • D & F orders | |
| Business Rules: | |
| Measurement of interval of completion date and time by a field technician on dispatched orders, and 5PM start time on the due date for non-dispatched orders; to the release of a notice to the CLEC/BST of the completion status. The field technician notifies the CLEC the work was complete and then he enters the completion time stamp information in his computer. This information switches through to the SOCS systems either completing the order or rejecting the order to the Work Management Center (WMC). If the completion is rejected, it is manually corrected and then completed by the WMC. The notice is returned on each individual order submitted and as the notice is sent electronically, it can only be switched to those orders that were submitted by the CLEC electronically. The start time is the completion stamp either by the field technician or the 5PM due date stamp; the end time is the time stamp the notice was submitted to the CLEC/BST system. | |
| Calculation: | |
| Σ (Date and Time of Notice of Completion) – (Date and Time of Work Completion) / (Number of Orders Completed in Reporting Period) | |
| Report Structure: | |
| <ul style="list-style-type: none"> • CLEC Specific • CLEC Aggregate • BST Aggregate | |
| Level of Disaggregation: | |
| <ul style="list-style-type: none"> • Reporting intervals in Hours: 0-1, 1-2, 2-4, 4-8, 8-12, 12-24, > 24, plus Overall Average Hour Interval • Reported in categories of <10 line/circuits; >= 10 line/circuits | |
| Data Retained Relating to CLEC Experience | Data Retained Relating to BST Experience |
| <ul style="list-style-type: none"> • Report Month • CLEC Order Number • Work Completion Date • Work Completion Time • Completion Notice Availability Date • Completion Notice Availability Time • Service Type • Activity Type • Geographic Scope | <ul style="list-style-type: none"> • Report Month • BST Order Number • Work Completion Date • Work Completion Time • Completion Notice Availability Date • Completion Notice Availability Time • Service Type • Activity Type • Geographic Scope |
| NOTE: Code in parentheses is the corresponding header found in the raw data file. | NOTE: Code in parentheses is the corresponding header found in the raw data file. |
| Retail Analog/Benchmark: | |
| CLEC Residence Resale / BST Residence Retail CLEC Business Resale / BST Business Retail CLEC Non-UNE Design / BST Design Interconnection Trunks-CLEC / Interconnection Trunks-BST UNEs – (See Appendix D) | |

Revision Date 02/24/00 (taf)

PROVISIONING

| | |
|--|--|
| Report/Measurement: | |
| P-6. Coordinated Customer Conversions | |
| Definition: | |
| This category measures the average time it takes BST to disconnect an unbundled loop from the BST switch and cross connect it to a CLEC's equipment. This measurement applies to service orders with and without INP, and where the CLEC has requested BST to provide a coordinated cutover. | |
| Exclusions: | |
| <ul style="list-style-type: none"> • Any order canceled by the CLEC will be excluded from this measurement. • Delays due to CLEC following disconnection of the unbundled loop • Unbundled Loops where there is no existing subscriber loop and loops where coordination is not requested. | |
| Business Rules: | |
| Where the service order includes INP, the interval includes the total time for the cutover including the translation time to place the line back in service on the ported line. The interval is calculated for the entire cutover time for the service order and then divided by items worked in that time to give the average per item interval for each service order. | |
| Calculation: | |
| $\Sigma [(Completion\ Date\ and\ Time\ for\ Cross\ Connection\ of\ an\ Coordinated\ Unbundled\ Loop) - (Disconnection\ Date\ and\ Time\ of\ an\ Coordinated\ Unbundled\ Loop)] / Total\ Number\ of\ Unbundled\ Loop\ with\ Coordinated\ Conversions\ (items)\ for\ the\ reporting\ period.$ | |
| Report Structure: | |
| <ul style="list-style-type: none"> • CLEC Specific • CLEC Aggregate | |
| Level of Disaggregation: | |
| Reported in intervals <=5 minutes; >5,<=15 minutes; >15 minutes, plus Overall Average interval | |
| Data Retained Relating to CLEC Experience | Data Retained Relating to BST Experience |
| <ul style="list-style-type: none"> • Report Month • CLEC Order Number • Committed Due Date (DD) • Service Type (CLASS_SVC_DESC) • Cutover Start Time • Cutover Completion time • Portability start and completion times (INP orders) • Total Conversions (Items) <p>NOTE: Code in parentheses is the corresponding header found in the raw data file.</p> | <ul style="list-style-type: none"> • No BST Analog Exists |
| Retail Analog/Benchmark: | |
| There is no retail analog for this measurement because it measures cutting loops to the CLEC. Benchmark – See Appendix D | |

Revision Date: 02/28/00 (taf)

PROVISIONING

| | |
|--|--|
| Report/Measurement: | |
| P-7. % Provisioning Troubles within 30 days of Service Order Activity | |
| Definition: | |
| Percent Provisioning Troubles within 30 days of Installation measures the quality and accuracy of installation activities. | |
| Exclusions: | |
| <ul style="list-style-type: none"> • Canceled Service Orders • Order Activities of BST or the CLEC associated with internal or administrative use of local services (R Orders, Test Orders, etc.) • D & F orders | |
| Business Rules: | |
| Measures the quality and accuracy of completed orders. The first trouble report from a service order after completion is counted in this measure. Subsequent trouble reports are measured in Repeat Report Rate. Reports are calculated searching in the prior report period for completed service orders and following 30 days after completion for a trouble report. | |
| D & F orders are excluded as there is no subsequent activity following a disconnect. | |
| Calculation: | |
| $\% \text{ Provisioning Troubles within 30 days of Service Order Activity} = \frac{\sum (\text{Trouble reports on all completed orders} \leq 30 \text{ days following service order(s) completion})}{(\text{All Service Orders completed in the report calendar month}) \times 100}$ | |
| Report Structure: | |
| <ul style="list-style-type: none"> • CLEC Specific • CLEC Aggregate • BST Aggregate | |
| Level of Disaggregation: | |
| <ul style="list-style-type: none"> • Reported in categories of <10 line/circuits; >= 10 line/circuits • Dispatch / No Dispatch | |
| Data Retained Relating to CLEC Experience | Data Retained Relating to BST Experience |
| <ul style="list-style-type: none"> • Report Month • CLEC Order Number and PON • Order Submission Date(TICKET_ID) • Order Submission Time (TICKET_ID) • Status Type • Status Notice Date • Standard Order Activity • Geographic Scope | <ul style="list-style-type: none"> • Report Month • BST Order Number • Order Submission Date • Order Submission Time • Status Type • Status Notice Date • Standard Order Activity • Geographic Scope |
| NOTE: Code in parentheses is the corresponding header found in the raw data file. | |
| Retail Analog/Benchmark: | |
| CLEC Residence Resale / BST Residence Retail CLEC Business Resale / BST Business Retail CLEC Non-UNE_Design / BST Design Interconnection Trunks-CLEC / Interconnection Trunks -BST UNES-(See Appendix D) | |

Revision Date: 02/28/00 (taf)

PROVISIONING

| | |
|--|--|
| Report/Measurement : | |
| P-8. Total Service Order Cycle Time (TSOCT) | |
| Definition: | |
| This report measures the total service order cycle time from receipt of a valid service order request to the completion of the service order. | |
| Exclusions: | |
| <ul style="list-style-type: none"> • Canceled Service Orders • Order Activities of BST or the CLEC associated with internal or administrative use of local services (Record Orders, Test Orders, etc.) • D (Disconnect) and F (From) orders. (From is disconnect side of a move order when the customer moves to a new address). • “L” Appointment coded orders (where the customer has requested a later than offered interval) • Orders with CLEC/Subscriber caused delays or CLEC/Subscriber requested due date changes. | |
| Business Rules: | |
| <p>The interval is determined for each order processed during the reporting period. This measurement combines two reports: FOC (Firm Order Confirmation) with Average Order Completion Interval.</p> <p>This interval starts with the receipt of a valid service order request and stops when the technician or system completes the order in SOCS. Elapsed time for each order is accumulated for each reporting dimension. The accumulated time for each reporting dimension is then divided by the associated total number of orders completed.</p> | |
| Calculation : | |
| <p>Total Service Order Cycle Time</p> $\frac{\Sigma(\text{Date and Time of Service Request Receipt}) - (\text{Completion Date and Time of Service Order}) (\text{SOCS HIST-CD DATE})}{(\text{Count of Orders Completed in Reporting Period})}$ | |
| Report Structure: | |
| <ul style="list-style-type: none"> • CLEC Specific • CLEC Aggregate • BST Aggregate | |
| Level of Disaggregation: | |
| <ul style="list-style-type: none"> • Reported in categories of < 10 line/circuits; > = 10 line/circuits • Dispatch/No Dispatch categories applicable to all levels except trunks. • Intervals 0-5, 5-10, 10-15, 15-20, 20-25, 25-30, > = 30 Days | |
| Data Retained Relating to CLEC Experience | Data Retained Relating to BST Experience |
| <ul style="list-style-type: none"> • Report Month • Interval for FOC • CLEC Company Name • Order Number (PON) • Submission Date & Time (TICKET_ID) • Completion Date (CMPLTN_DT) • Service Type (CLASS_SVC_DESC) • Geographic Scope | <ul style="list-style-type: none"> • Report Month • BST Order Number • Order Submission Date & Time • Order Completion Date & Time • Service Type • Geographic Scope |
| <p>NOTE: Code in parentheses is the corresponding header found in the raw data file.</p> | |
| Retail Analog/Benchmark | |
| See Appendix D | |

Revision Date: 02/28/00 (taf)

PROVISIONING

| | |
|---|---|
| Report/Measurement: | |
| P-9. Service Order Accuracy <u>GEORGIA ONLY</u> | |
| Definition: | |
| The “service order accuracy” measurement measures the accuracy and completeness of BST service orders by comparing what was ordered and what was completed. | |
| Exclusions: | |
| <ul style="list-style-type: none"> • Cancelled Service Orders • Order Activities of BST associated with internal or administrative use of local services • & F orders | |
| Business Rules: | |
| A manual sampling of service orders, completed during a monthly reporting period, is compared to the original account profile and the order that the CLEC sent to BST. An order is “completed without error” if all service attributes and account detail changes (as determined by comparing the original order) completely and accurately reflect the activity specified on the original order and any supplemental CLEC order. | |
| Calculation: | |
| Percent Service Order Accuracy = Σ (Orders Completed without Error) / Σ (Orders Completed in Reporting Period) x 100 | |
| Report Structure: | |
| CLEC Aggregate | |
| Level of Disaggregation: | |
| <ul style="list-style-type: none"> • Reported in categories of <10 line/circuits; > = 10 line/circuits • Dispatch / No Dispatch | |
| Data Retained Relating to CLEC Experience | Data Retained Relating to BST Experience |
| <ul style="list-style-type: none"> • Report Month • CLEC Order Number and PON • Local Service Request (LSR) • Order Submission Date • Committed Due Date • Service Type • Standard Order Activity | <ul style="list-style-type: none"> • Being investigated at this time |
| NOTE: Code in parentheses is the corresponding header found in the raw data file. | |
| Retail Analog/Benchmark: (Under Investigation) | |

Revision Date: 01/05/00 (taf)

PROVISIONING

| |
|--|
| Report/Measurement: |
| LNP – 10. Percent Missed Installation Appointments |
| Definition: |
| Percent Missed Installation Appointments monitors the reliability of BST commitments with respect to committed due dates to assure that CLECs can reliably quote expected due dates to their retail customer as compared to BST. |
| Exclusions: |
| <ul style="list-style-type: none"> • Canceled Service Orders • Order Activities of BST or the CLEC associated with internal or administrative use of local services (Record Orders, Test Orders, etc.) where identifiable. |
| Business Rules: |
| Percent Missed Installation Appointments (PMI) is the percentage of total orders processed for which BST is unable to complete the service orders on the committed due dates. Missed Appointments caused by end-user reasons will be included and reported in a separate category. A business day is any time period within the same date frame, which means there cannot be a cutoff time for commitments as certain types of orders are requested to be worked after standard business hours. Also, during Daylight Savings Time, field technicians are scheduled until 9PM in some areas and the customer is offered a greater range of intervals from which to select. |
| Calculation: |
| <p>Percent Missed Installation Appointments: [(Number of Orders Not Completed by Committed Due Date in Reporting Period) / (Number of Orders Completed in Reporting Period)] X 100</p> |
| Report Structure: |
| <ul style="list-style-type: none"> • Mechanized (service orders generated by LSRs submitted via EDI or TAG) • CLEC Specific • CLEC Aggregate <p>Report explanation: Total Missed Appointments is the total % of orders missed either by BST or the CLEC end user. End User MA represents the percentage of orders missed by the CLEC end user. The difference between End User Missed Appointments and Total Missed Appointments is the result of BST caused misses.</p> |
| Level of Disaggregation: |
| <ul style="list-style-type: none"> • Product Reporting Levels <ul style="list-style-type: none"> ➢ LNP ➢ UNE Loop Associated w/LNP • Geographic Scope <ul style="list-style-type: none"> ➢ State, Region |
| Retail Analog/Benchmark: |
| See Appendix D |

Revision Date: 02/16/00 (taf)

PROVISIONING – (LNP)

| |
|--|
| Report/Measurement : |
| LNP-11. Average Disconnect Timeliness Interval & Disconnect Timeliness Interval Distribution |
| Definition: |
| Disconnect Timeliness is defined as the interval between the time the LNP Gateway receives the ‘Number Ported’ message from NPAC (signifying the CLEC ‘Activate’) until the time that the Disconnect service order for an LSR is completed in SOCS. This interval effectively measures BST responsiveness by isolating it from impacts that are caused by CLEC related activities. |
| Exclusions: |
| <ul style="list-style-type: none"> • Canceled Service Orders • Order Activities of BST or the CLEC associated with internal or administrative use of local services (Record Orders, Test Orders, etc.) where identifiable. |
| Business Rules: |
| The Disconnect Timeliness interval is determined for the last Disconnect service order processed on an LSR during the reporting period. The Disconnect Timeliness interval is the elapsed time from when BST receives the last ‘Number Ported’ message for an LSR from NPAC (signifying the CLEC ‘Activate’) until the last Disconnect service order is completed in SOCS. Elapsed time for each order is accumulated for each reporting dimension. The accumulated time for each reporting dimension is then divided by the total number of selected disconnect orders which have been completed. |
| Calculation : |
| <p>Average Disconnect Timeliness Interval: $\frac{\Sigma[(\text{Disconnect Service Order Completion Date \& Time}) - (\text{‘Number Ported’ Message Received Date \& Time})]}{\Sigma(\text{Total Number of Disconnect Service Orders Completed in Reporting Period})}$</p> <p>Disconnect Timeliness Interval Distribution: $[\Sigma(\text{Disconnect Service Orders Completed in “X” days}) / (\text{Total Disconnect Service Orders Completed in Reporting Period})] \times 100$</p> |
| Report Structure: |
| <ul style="list-style-type: none"> • Mechanized (service orders generated by LSRs submitted via EDI or TAG) • CLEC Specific • CLEC Aggregate |
| Level of Disaggregation: |
| <ul style="list-style-type: none"> • Reported in day intervals = 0,1,2,3,4, 5, >5 days • Product Reporting Levels <ul style="list-style-type: none"> ➢LNP • Geographic Scope <ul style="list-style-type: none"> ➢State, Region |
| Retail Analog/Benchmark: |
| See Appendix D |

Revision Date: 02/16/00 (taf)

PROVISIONING

| |
|---|
| Report/Measurement : |
| LNP-12. Total Service Order Cycle Time |
| Definition: |
| Total Service Order Cycle Time measures the interval from receipt of a valid service order request to the completion of the final service order associated with that service request. |
| Exclusions: |
| <ul style="list-style-type: none"> • Canceled Service Orders • Order Activities of BST or the CLEC associated with internal or administrative use of local services (Record Orders, Test Orders, etc.) where identifiable • “L” appointment coded orders (indicating the customer has requested a later than offered interval) • ”S” missed appointment coded orders (indicating subscriber missed reasons), except for “SP” codes (indicating subscriber prior due date requested). |
| Business Rules: |
| <p>The interval is determined for each service request processed during the reporting period. This measurement combines two reports: FOC (Firm Order Confirmation) with Average Order Completion Interval.</p> <p>This interval starts with the receipt of a valid service request and stops when the technician or system completes all the related service orders for the LSR in SOCS. Elapsed time for each service request is accumulated for each reporting dimension. The accumulated time for each reporting dimension is then divided by the associated total number of service requests completed to produce the total service order cycle time.</p> |
| Calculation : |
| <p>Average Total Service Order Cycle Time: $\frac{\Sigma [(\text{Service Order Completion Date \& Time}) - (\text{Service Request Receipt Date \& Time})]}{\Sigma (\text{Total Number Service Requests Completed in Reporting Period})}$</p> <p>Total Service Order Cycle Time Interval Distribution: $[\frac{\Sigma (\text{Total Number of Service Requests Completed in “X” minutes/hours})}{(\text{Total Number of Service Requests Received in Reporting Period})}] \times 100$</p> |
| Report Structure: |
| <ul style="list-style-type: none"> • Mechanized (service orders generated by LSRs submitted via EDI or TAG) • CLEC Specific • CLEC Aggregate • “W” Appointment Code Only (Company Offered) |
| Level of Disaggregation: |
| <ul style="list-style-type: none"> • Reported in day intervals 0 - 5, 5 - 10, 10 - 15, 15 - 20, 20 - 25, 25 - 30, >30 days • Product Reporting Levels <ul style="list-style-type: none"> ➢ LNP ➢ UNE Loop with LNP • Geographic Scope <ul style="list-style-type: none"> ➢ State, Region |
| Retail Analog/Benchmark: |
| See Appendix D |

Revision Date: 02/16/00 (taf)

Maintenance and Repair Level of Disaggregation

Product Reporting Levels

- Resale / Retail
 - Pots – Residence
 - Pots – Business
 - PBX (Louisiana SQM)
 - ESSX (Louisiana SQM)
 - CENTREX (Louisiana SQM)
 - ISDN (Louisiana SQM) (**NOTE:** ISDN Troubles included in Non-Design Georgia Only)
 - Design

- Unbundled Network Elements
 - UNE Design
 - UNE Non – Design
 - UNE 2 Wire Loop (Louisiana SQM)
 - UNE Loop Other (Louisiana SQM)
 - Unbundled Ports (Louisiana SQM)
 - UNE Other Non – Design (Louisiana SQM)

- Trunks
 - Local Interconnection Trunks

- Dispatch/No Dispatch categories applicable to all product levels

- Geographic Scope

- State, Region and further geographic disaggregation as required by State Commission Order (e.g. Metropolitan Service Area – MSA)

MAINTENANCE & REPAIR

| | |
|---|--|
| Report/Measurement: | |
| M&R-1. Missed Repair Appointments | |
| Definition: | |
| The percent of trouble reports not cleared by the committed date and time. | |
| Exclusions: | |
| <ul style="list-style-type: none"> • Trouble tickets canceled at the CLEC request. • BST trouble reports associated with internal or administrative service. • Customer Provided Equipment (CPE) troubles or CLEC Equipment Trouble. | |
| Business Rules: | |
| The negotiated commitment date and time is established when the repair report is received. The cleared time is the date and time that BST personnel clear the trouble and closes the trouble report in his Computer Access Terminal (CAT) or workstation. If this is after the Commitment time, the report is flagged as a “Missed Commitment” or a missed repair appointment. When the data for this measure is collected for BST and a CLEC, it can be used to compare the percentage of the time repair appointments are missed due to BST reasons. Note: Appointment intervals vary with force availability in the POTS environment. Specials and Trunk intervals are standard interval appointments of no greater than 24 hours. | |
| Calculation: | |
| Percentage of Missed Repair Appointments = $\frac{\Sigma (\text{Count of Customer Troubles Not Cleared by the Quoted Commitment Date and Time})}{\Sigma (\text{Total Trouble reports closed in Reporting Period})} \times 100$ | |
| Report Structure: | |
| <ul style="list-style-type: none"> • CLEC Specific • CLEC Aggregate • BST Aggregate | |
| Data Retained Relating to CLEC Experience | Data Retained Relating to BST Experience |
| <ul style="list-style-type: none"> • Report Month • CLEC Company Name • Submission Date & Time (TICKET_ID) • Completion Date (Cmpltn_DT) • Service Type (CLASS_SVC_DESC) • Disposition and Cause (CAUSE_CD & CAUSE_DESC) • Geographic Scope | <ul style="list-style-type: none"> • Report Month • BST Company Code • Submission Date & Time • Completion Date • Service Type • Disposition and Cause (Non-Design /Non-Special Only) • Trouble Code (Design and Trunking Services) • Geographic Scope |
| NOTE: Code in parentheses is the corresponding header found in the raw data file. | |
| Retail Analog/Benchmark | |
| CLEC Residence-Resale / BST Residence-Retail CLEC Business-Resale / BST Business-Retail CLEC Design-Resale / BST Design-Retail CLEC PBX, Centrex, and ISDN Resale/ BST PBX, Centrex, and ISDN Retail CLEC Trunking-Resale / BST Trunking-Retail UNEs – (See Appendix D) | |

Revision Date: 02/22/00 (see)

MAINTENANCE & REPAIR

| | |
|--|---|
| Report/Measurement: | |
| M&R-2. Customer Trouble Report Rate | |
| Definition: | |
| Initial and repeated customer direct or referred troubles reported within a calendar month per 100 lines/ circuits in service. | |
| Exclusions: | |
| <ul style="list-style-type: none"> • Trouble tickets canceled at the CLEC request. • BST trouble reports associated with administrative service. • Customer provided Equipment (CPE) troubles or CLEC equipment troubles. | |
| Business Rules: | |
| Customer Trouble Report Rate is computed by accumulating the number of maintenance initial and repeated trouble reports during the reporting period. The resulting number of trouble reports are divided by the total “number of service” lines, ports or combination that exist for the CLEC’s and BST respectively at the end of the report month. | |
| Calculation: | |
| Customer Trouble Report Rate = (Count of Initial and Repeated Trouble Reports in the Current Period) / (Number of Service Access Lines in service at End of the Report Period) X 100 | |
| Report Structure: | |
| <ul style="list-style-type: none"> • CLEC Specific • CLEC Aggregate • BST Aggregate | |
| Data Retained Relating to CLEC Experience | Data Retained Relating to BST Experience |
| <ul style="list-style-type: none"> • Report Month • CLEC Company Name • Ticket Submission Date & Time (TICKET_ID) • Ticket Completion Date (CMPLTN_DT) • Service Type (CLASS_SVC_DESC) • Disposition and Cause (CAUSE_CD & CAUSE_DESC) • # Service Access Lines in Service at the end of period • Geographic Scope | <ul style="list-style-type: none"> • Report Month • BST Company Code • Ticket Submission Date & Time • Ticket Completion Date • Service Type • Disposition and Cause (Non-Design / Non-Special Only) • Trouble Code (Design and Trunking Services) • # Service Access Lines in Service at the end of period • Geographic Scope |
| NOTE: Code in parentheses is the corresponding header found in the raw data file. | |
| Retail Analog/Benchmark: | |
| CLEC Residence-Resale / BST Residence -Retail CLEC Business-Resale / BST Business-Retail CLEC Design-Resale / BST Design-Retail CLEC PBX, Centrex and ISDN Resale/ BST PBX, Centrex, and ISDN Retail CLEC Trunking-Resale / BST Trunking-Retail UNES – (See Appendix D) | |

Revision Date: 02/22/00 (see)

MAINTENANCE & REPAIR

| | |
|--|---|
| Report/Measurement: | |
| M&R-3. Maintenance Average Duration | |
| Definition: | |
| The Average duration of Customer Trouble Reports from the receipt of the Customer Trouble Report to the time the trouble report is cleared. | |
| Exclusions: | |
| <ul style="list-style-type: none"> • Trouble reports canceled at the CLEC request • BST trouble reports associated with administrative service • Customer Provided Equipment (CPE) troubles or CLEC Equipment Troubles. • Trouble reports greater than 10 days | |
| Business Rules: | |
| For Average Duration the clock starts on the date and time of the receipt of a correct repair request. The clock stops on the date and time the service is restored and the customer notified (when the technician completes the trouble ticket on his/her CAT or work system). | |
| NOTE: Customer can be BST or CLEC | |
| Calculation: | |
| Maintenance Average Duration = $\Sigma(\text{Date and Time of Service Restoration}) - (\text{Date and Time Trouble Ticket was Opened}) / \Sigma(\text{Total Closed Troubles in the reporting period})$ | |
| Report Structure: | |
| <ul style="list-style-type: none"> • CLEC Specific • BST Aggregate • CLEC Aggregate | |
| Data Retained Relating to CLEC Experience | Data Retained Relating to BST Experience |
| <ul style="list-style-type: none"> • Report Month • Total Tickets (LINE_NBR) • CLEC Company Name • Ticket Submission Date & Time (TIME_ID) • Ticket Completion Date (CMPLTN_DT) • Service Type (CLASS_SVC_DESC) • Disposition and Cause (CAUSE_CD & CAUSE_DESC) • Geographic Scope | <ul style="list-style-type: none"> • Report Month • Total Tickets • BST Company Code • Ticket Submission Date • Ticket submission Time • Ticket completion Date • Ticket Completion Time • Total Duration Time • Service Type • Disposition and Cause (Non – Design /Non-Special Only) • Trouble Code (Design and Trunking Services) • Geographic Scope |
| NOTE: Code in parentheses is the corresponding header found in the raw data file. | |
| Retail Analog/Benchmark: | |
| CLEC Residence-Resale / BST Residence-Resale CLEC Business-Resale / BST Business-Retail CLEC Design-Resale / BST Design-Retail CLEC PBX, Centrex and ISDN Resale / BST PBX, Centrex and ISDN Retail CLEC Trunking-Resale /BST Trunking-Retail UNEs – (See Appendix D) | |

Revision Date: 02/22/00 (see)

MAINTENANCE & REPAIR

| | |
|---|--|
| Report/Measurement: | |
| M&R-4. Percent Repeat Troubles within 30 Days | |
| Definition: | |
| Trouble reports on the same line/circuit as a previous trouble report received within 30 calendar days as a percent of total troubles reported. | |
| Exclusions: | |
| <ul style="list-style-type: none"> • Trouble Reports canceled at the CLEC request • BST Trouble Reports associated with administrative service • Customer Provided Equipment (CPE) Troubles or CLEC Equipment Troubles. | |
| Business Rules: | |
| Includes Customer trouble reports received within 30 days of an original Customer trouble report. | |
| Calculation: | |
| Percent Repeat Troubles within 30 Days = (Count of Customer Troubles where more than one trouble report was logged for the same service line within a continuous 30 days) / (Total Trouble Reports Closed in Reporting Period) X 100 | |
| Report Structure: | |
| <ul style="list-style-type: none"> • CLEC Specific • CLEC Aggregate • BST Aggregate | |
| Data Retained Relating to CLEC Experience | Data Retained Relating to BST Experience |
| <ul style="list-style-type: none"> • Report Month • Total Tickets (LINE_NBR) • CLEC Company Name • Ticket Submission Date & Time (TICKET_ID) • Ticket Completion Date (CMPLTN_DT) • Total and Percent Repeat Trouble Reports within 30 Days (TOT_REPEAT) • Service Type • Disposition and Cause (CAUSE_CD & CAUSE_DESC) • Geographic Scope <p>NOTE: Code parentheses is the corresponding header format found in the raw data file.</p> | <ul style="list-style-type: none"> • Report Month • Total Tickets • BST Company Code • Ticket Submission Date • Ticket Submission Time • Ticket Completion Date • Ticket Completion Time • Total and Percent Repeat Trouble Reports within 30 Days • Service Type • Disposition and Cause (Non – Design/Non-Special only) • Trouble Code (Design and Trunking Services) • Geographic Scope |
| Retail Analog/Benchmark: | |
| CLEC Residence-Resale / BST Residence-Retail CLEC Business- Resale / BST Business-Retail CLEC Design-Resale / BST Design-Retail CLEC PBX, Centrex and ISDN Resale / BST PBX, Centrex and ISDN Retail CLEC Trunking-Resale / BST Trunking-Retail UNEs – Retail Analog (See Appendix D) | |

Revision date: 02/22/00 (see)

MANTENANCE & REPAIR

| | |
|--|--|
| Report/Measurement: | |
| M&R-5. Out of Service (OOS) > 24 Hours | |
| Definition: | |
| For Out of Service Troubles (no dial tone, cannot be called or cannot call out) the percentage of troubles cleared in excess of 24 hours. (All design services are considered to be out of service). | |
| Exclusions: | |
| <ul style="list-style-type: none"> • Trouble Reports canceled at the CLEC request • BST Trouble Reports associated with administrative service • Customer Provided Equipment (CPE) Troubles or CLEC Equipment Troubles. | |
| Business Rules: | |
| Customer Trouble reports that are out of service and cleared in excess of 24 hours. The clock begins when the trouble report is created in LMOS and the trouble is counted if the time exceeds 24 hours. | |
| Calculation: | |
| Out of Service (OOS) > 24 hours = (Total Troubles OOS > 24 Hours) / Total OOS Troubles in Reporting Period) X 100 | |
| Report Structure: | |
| <ul style="list-style-type: none"> • CLEC Specific • BST Aggregate • CLEC Aggregate | |
| Data Retained Relating to CLEC Experience | Data Retained Relating to BST Experience |
| <ul style="list-style-type: none"> • Report Month • Total Tickets • CLEC Company Name • Ticket Submission Date & Time (TICKET_ID) • Ticket Completion Date (CMPLTN_DT) • Percentage of Customer Troubles out of Service > 24 Hours (OOS>24_FLAG) • Service type (CLASS_SVC_DESC) • Disposition and Cause (CAUSE_CD & CAUSE-DESC) • Geographic Scope | <ul style="list-style-type: none"> • Report Month • Total Tickets • BST Company Code • Ticket Submission Date • Ticket Submission time • Ticket Completion Date • Ticket Completion Time • Percent of Customer Troubles out of Service > 24 Hours • Service type • Disposition and Cause (Non – Design/Non-Special only) • Trouble Code (Design and Trunking Services) • Geographic Scope |
| NOTE: Code in parentheses is the corresponding header found in the raw data file. | |
| Retail Analog/Benchmark: | |
| CLEC Residence-Resale / BST Residence- Retail CLEC Business- Resale / BST Business-Retail CLEC Design-Resale / BST Design-Retail CLEC PBX, Centrex and ISDN Resale / BST PBX, Centrex and ISDN Retail CLEC Trunking-Resale /BST Trunking- Retail UNEs Retail Analog – (See Appendix D) | |

Revision Date: 02/22/00 (see)

MAINTENANCE & REPAIR

| | |
|--|---|
| Report/Measurement: | |
| M&R-6. Average Answer Time – Repair Centers | |
| Definition: | |
| This measures the average time a customers is in Que. | |
| Exclusions: | |
| None | |
| Business Rules: | |
| This measure is designed to measure the time required for CLEC & BST from the time of the ACD choice to the time of being answered. The clock starts when the CLEC Rep makes a choice to be put in queue for the next repair attendant and the clock stops when the repair attendant answers the call. | |
| (NOTE: The Column is a combined BST Residence and Business number) | |
| Level of Disaggregation: | |
| Region. CLEC/BST Service Centers and BST Repair Centers are regional. | |
| Calculation: | |
| Average Answer Time for BST’s Repair Centers = (Time BST Repair Attendant Answers Call) – (Time of entry into queue until ACD Selection) / (Total number of calls by reporting period) | |
| Report Structure: | |
| <ul style="list-style-type: none"> • CLEC Aggregate • BST Aggregate | |
| Data Retained Relating to CLEC Experience | Data Retained Relating to BST Experience |
| <ul style="list-style-type: none"> • CLEC Average Answer Time | <ul style="list-style-type: none"> • BST Average Answer Time |
| Retail Analog/Benchmark: | |
| For CLEC, Average Answer Times in UNE Center and BRMC are comparable to the Average Answer Times in the BST Repair Centers. See Appendix D | |

Revision Date: 02/22/00 (see)

BILLING

| | |
|--|--|
| Report/Measurement: | |
| B-1. Invoice Accuracy | |
| Definition: | |
| This measure provides the percentage of accuracy of the billing invoices rendered to CLECs during the current month. | |
| Exclusions: | |
| <ul style="list-style-type: none"> • Adjustments not related to billing errors (e.g., credits for service outage, special promotion credits, adjustments to satisfy the customer) | |
| Business Rules: | |
| The accuracy of billing invoices delivered by BST to the CLEC must enable them to provide a degree of billing accuracy comparative to BST bills rendered to retail customers BST. CLECs request adjustments on bills determined to be incorrect. The BellSouth Billing verification process includes manually analyzing a sample of local bills from each bill period. The bill verification process draws from a mix of different customer billing options and types of service. An end-to-end auditing process is performed for new products and services. Internal measurements and controls are maintained on all billing processes. | |
| Calculation: | |
| $\text{Invoice Accuracy} = \frac{(\text{Total Billed Revenues during current month}) - (\text{Billing Related Adjustments during current month})}{\text{Total Billed Revenues during current month}} \times 100$ | |
| Report Structure: | |
| <ul style="list-style-type: none"> • CLEC Specific • CLEC Aggregate • BST Aggregate | |
| Level of Disaggregation : | |
| <ul style="list-style-type: none"> • Product / Invoice Type <ul style="list-style-type: none"> ➢ Resale ➢ UNE ➢ Interconnection • Geographic Scope <ul style="list-style-type: none"> ➢ Region | |
| Data Retained Relating to CLEC Experience: | Data Retained Relating to BST Performance: |
| <ul style="list-style-type: none"> • Report Month • Invoice Type • Total Billed Revenue • Billing Related Adjustments | <ul style="list-style-type: none"> • Report Month • Retail Type <ul style="list-style-type: none"> ➢ CRIS ➢ CABS • Total Billed Revenue • Billing Related Adjustments |
| Retail Analog/Benchmark | |
| CLEC Invoice Accuracy is comparable to BST Invoice Accuracy See Appendix D | |

Revision Date: 02/28/00 (dg)

BILLING

| | |
|--|---|
| Report/Measurement: | |
| B-2. Mean Time to Deliver Invoices | |
| Definition: | |
| This measure provides the mean interval for billing invoices | |
| Exclusions: | |
| Any invoices rejected due to formatting or content errors. | |
| Business Rules: | |
| Measures the mean interval for timeliness of billing records delivered to CLECs in an agreed upon format. CRIS-based invoices are measured in business days, and CABS-based invoices in calendar days. | |
| Calculation: | |
| Mean Time To Deliver Invoices = $\sum_{i=1}^n [(\text{Invoice Transmission Date}) - (\text{Close Date of Scheduled Bill Cycle})] / (\text{Count of Invoices Transmitted in Reporting Period})$ | |
| Report Structure: | |
| <ul style="list-style-type: none"> • CLEC Specific • CLEC Aggregate • BST Aggregate | |
| Level of Disaggregation: | |
| <ul style="list-style-type: none"> • Product / Invoice Type <ul style="list-style-type: none"> ➢ Resale ➢ UNE ➢ Interconnection • Geographic Scope <ul style="list-style-type: none"> ➢ Region | |
| Data Retained Relating to CLEC Experience: | Data Retained Relating to BST Performance: |
| <ul style="list-style-type: none"> • Report Month • Invoice Type • Invoice Transmission Count • Date of Scheduled Bill Close | <ul style="list-style-type: none"> • Report Month • Retail Type <ul style="list-style-type: none"> ➢ CRIS ➢ CABS • Invoice Transmission Count • Date of Scheduled Bill Close |
| Retail Analog/Benchmark: | |
| <p>CRIS-based invoices will be released for delivery within six (6) business days CABS-based invoices will be released for delivery within eight (8) calendar days. CLEC Average Delivery Intervals for both CRIS and CABS Invoices are comparable to BST Average delivery for both systems. See Appendix D</p> | |

Revision Date: 02/28/00 (dg)

BILLING

| | |
|--|---|
| Report/Measurement: | |
| B-3. Usage Data Delivery Accuracy | |
| Definition: | |
| This measurement captures the percentage of recorded usage that is delivered error free and in an acceptable format to the appropriate Competitive Local Exchange Carrier (CLEC). These percentages will provide the necessary data for use as a comparative measurement for BellSouth performance. This measurement captures Data Delivery Accuracy rather than the accuracy of the individual usage recording. | |
| Exclusions: | |
| None | |
| Business Rules: | |
| The accuracy of the data delivery of usage records delivered by BST to the CLEC must enable them to provide a degree of accuracy comparative to BST bills rendered to their retail customers. If errors are detected in the delivery process, they are investigated, evaluated and documented. Errors are corrected and the data retransmitted to the CLEC. | |
| Calculations: | |
| Usage Data Delivery Accuracy = $\frac{\Sigma[(\text{Total number of usage data packs sent during current month}) - (\text{Total number of usage data packs requiring retransmission during current month})]}{(\text{Total number of usage data packs sent during current month})} \times 100$ | |
| Report Structure: | |
| <ul style="list-style-type: none"> • CLEC Specific • CLEC Aggregate • BST Aggregate | |
| Level of Disaggregation: | |
| <ul style="list-style-type: none"> • Geographic Scope <ul style="list-style-type: none"> ➢ Region | |
| Data Retained Relating to CLEC Experience: | Data Retained Relating to BST Performance: |
| <ul style="list-style-type: none"> • Report Month • Record Type <ul style="list-style-type: none"> ➢ BellSouth Recorded ➢ Non BellSouth Recorded | <ul style="list-style-type: none"> • Report Month • Record Type |
| Retail Analog/Benchmark: | |
| CLEC Usage Data Delivery Accuracy is comparable to BST Usage Data Delivery Accuracy See Appendix D | |

Revision Date: 02/28/00 (dg)

BILLING

| | |
|--|---|
| Report/Measurement: | |
| B-4. Usage Data Delivery Completeness | |
| Definition: | |
| <p>This measurement provides percentage of complete and accurately recorded usage data (usage recorded by BellSouth and usage recorded by other companies and sent to BST for billing) that is processed and transmitted to the CLEC within thirty (30) days of the message recording date. A parity measure is also provided showing completeness of BST messages processed and transmitted via CMDS. BellSouth delivers its own retail usage from recording location to billing location via CMDS as well as delivering billing data to other companies. Timeliness, Completeness and Mean Time to Deliver Usage measures are reported on the same report.</p> | |
| Exclusions: | |
| None | |
| Business Rules: | |
| <p>The purpose of these measurements is to demonstrate the level of quality of usage data delivered to the appropriate CLEC. Method of delivery is at the option of the CLEC.</p> | |
| Calculation: | |
| <p>Usage Data Delivery Completeness = $\Sigma(\text{Total number of Recorded usage records delivered during the current month that are within thirty (30) days of the message recording date}) / \Sigma(\text{Total number of Recorded usage records delivered during the current month}) \times 100$</p> | |
| Report Structure | |
| <ul style="list-style-type: none"> • CLEC Specific • CLEC Aggregate • BST Aggregate | |
| Level of Disaggregation: | |
| <ul style="list-style-type: none"> • Geographic Scope <ul style="list-style-type: none"> ➢ Region | |
| Data Retained Relating to CLEC Experience: | Data Retained Relating to BST Performance: |
| <ul style="list-style-type: none"> • Report Month • Record Type <ul style="list-style-type: none"> ➢ BellSouth Recorded ➢ Non BellSouth Recorded | <ul style="list-style-type: none"> • Report Monthly • Record Type |
| Retail Analog/Benchmark: | |
| <p>CLEC Usage Delivery Completeness is comparable to BST Usage Delivery Completeness See Appendix D</p> | |

Revision Date: 02/28/00 (dg)

BILLING

| | |
|--|---|
| Report/Measurement: | |
| B-5. Usage Data Delivery Timeliness | |
| Definition: | |
| This measurement provides a percentage of recorded usage data (usage recorded by BST and usage recorded by other companies and sent to BST for billing) that is delivered to the appropriate CLEC within six (6) calendar days from the receipt of the initial recording. A parity measure is also provided showing timeliness of BST messages processed and transmitted via CMDS. Timeliness, Completeness and Mean Time to Deliver Usage measures are reported on the same report. | |
| Exclusions: | |
| None | |
| Business Rules: | |
| The purpose of this measurement is to demonstrate the level of timeliness for processing and transmission of usage data delivered to the appropriate CLEC. The usage data will be mechanically transmitted or mailed to the CLEC data processing center once daily. The Timeliness interval of usage recorded by other companies is measured from the date BST receives the records to the date BST distributes to the CLEC. Method of delivery is at the option of the CLEC. | |
| Calculation: | |
| Usage Data Delivery Timeliness = $\frac{\Sigma(\text{Total number of usage records sent within six (6) calendar days from initial recording/receipt})}{\Sigma(\text{Total number of usage records sent})} \times 100$ | |
| Report Structure: | |
| <ul style="list-style-type: none"> • CLEC Aggregate • CLEC Specific • BST Aggregate | |
| Level of Disaggregation: | |
| <ul style="list-style-type: none"> • Geographic Scope <ul style="list-style-type: none"> ➢ Region | |
| Data Retained Relating to CLEC Experience: | Data Retained Relating to BST Performance: |
| <ul style="list-style-type: none"> • Report Month • Record Type <ul style="list-style-type: none"> ➢ BellSouth Recorded ➢ Non-BellSouth Recorded | <ul style="list-style-type: none"> • Report Monthly • Record Type |
| Retail Analog/Benchmark: | |
| CLEC Usage Data Delivery Timeliness is comparable to BST Usage Data Delivery Timeliness See Appendix D | |

Revision date: 02/28/00 (dg)

BILLING

| | |
|--|---|
| Report/Measurement: | |
| B-6. Mean Time to Deliver Usage | |
| Definition: | |
| This measurement provides the average time it takes to deliver Usage Records to a CLEC. A parity measure is also provided showing timeliness of BST messages processed and transmitted via CMDS. Timeliness, Completeness and Mean Time to Deliver Usage measures are reported on the same report. | |
| Exclusions: | |
| None | |
| Business Rules: | |
| The purpose of this measurement is to demonstrate the average number of days it takes BST to deliver Usage data to the appropriate CLEC. Usage data is mechanically transmitted or mailed to the CLEC data processing center once daily. Method of delivery is at the option of the CLEC. | |
| Calculation: | |
| Mean Time to Deliver Usage = Σ (Record volume X estimated number of days to deliver the Usage Record) / total record volume | |
| Report Structure: | |
| <ul style="list-style-type: none"> • CLEC Aggregate • CLEC Specific • BST Aggregate | |
| Level of Disaggregation: | |
| <ul style="list-style-type: none"> • Geographic Scope <ul style="list-style-type: none"> ➢ Region | |
| Data Retained Relating to CLEC Experience: | Data Retained Relating to BST Performance: |
| <ul style="list-style-type: none"> • Report Month • Record Type <ul style="list-style-type: none"> ➢ BellSouth Recorded ➢ Non-BellSouth Recorded | <ul style="list-style-type: none"> • Report Monthly • Record Type |
| Retail Analog/Benchmark: | |
| Mean Time to Deliver Usage to CLEC is comparable to Mean Time to Deliver Usage to BST See Appendix D | |

Revision Date: 02/28/00 (dg)

OPERATOR SERVICES

| |
|--|
| Report/Measurement: |
| OS-1. Speed to Answer Performance/Average Speed to Answer – Toll |
| Definition: |
| Measurement of the average time in seconds calls wait before answered by a toll operator. |
| Exclusions: |
| Calls abandoned by customers are not reflected in the average speed to answer but are reflected in the conversion tables where the percent answered within “X” seconds is determined. |
| Business Rules: |
| The call waiting measurement scan starts when the customer enters the queue and ends when a BST representative answers the call. The average speed to answer is determined by measuring and accumulating the seconds of wait time from the entry of a customer into the BST call management system queue until the customer is transferred to a BST representative. No distinction is made between CLEC customers and BST customers. |
| Calculation: |
| The Average Speed to Answer for toll is calculated by using data from monthly system measurement reports taken from the centralized call routing switches. The “total call waiting seconds” is a sub-component of this measure which BST systems calculate by monitoring the number of calls in queue throughout the day multiplied by the time (in seconds) between monitoring events. The “total calls served” is the other sub-component of this measure, which BST systems record as the total number of calls handled by Operator Services toll centers. Since calls abandoned are not reflected in the calculation, the percent answered within the required timeframe is determined by using conversion tables with input for the abandonment rate. |
| Report Structure: |
| <ul style="list-style-type: none"> • Reported for the aggregate of BST and CLECs <ul style="list-style-type: none"> ➤ State |
| Level of Disaggregation: |
| None |
| Data Retained (on Aggregate Basis) |
| For the items below, BST’s Performance Measurement Analysis Platform (PMAP) receives a final computation; therefore, no raw data file is available in PMAP. <ul style="list-style-type: none"> • Month • Call Type (Toll) • Average Speed of Answer |
| Retail Analog/Benchmark |
| Parity by Design See Appendix D |

Revision Date: 02/28/00 (tg)

OPERATOR SERVICES

| |
|--|
| Report/Measurement: |
| OS-2. Speed to Answer Performance/Percent Answered within “X” Seconds – Toll |
| Definition: |
| Measurement of the percent of toll calls that are answered in less than “X” seconds. The number of seconds represented by “X” is thirty, except where a different regulatory benchmark has been set against the Average Speed to Answer by a State Commission. |
| Exclusions: |
| Calls abandoned by customers are not reflected in the average speed to answer but are reflected in the conversion tables where the percent answered within “X” seconds is determined. |
| Business Rules: |
| The call waiting measurement scan starts when the customer enters the queue and ends when a BST representative answers the call. The average speed to answer is determined by measuring and accumulating the seconds of wait time from the entry of a customer into the BST call management system queue until the customer is transferred to a BST representative. No distinction is made between CLEC customers and BST customers. |
| Calculation: |
| The Percent Answered within “X” Seconds measurement for toll is derived by using the BellCore Statistical Answer Conversion Tables, to convert the Average Speed to Answer measure into a percent of calls answered within “X” seconds. The BellCore Conversion Tables are specific to the defined parameters of work time, number of operators, max queue size and call abandonment rates. |
| Report Structure: |
| <ul style="list-style-type: none"> • Reported for the aggregate of BST and CLECs <ul style="list-style-type: none"> ➤ State |
| Level of Disaggregation: |
| None |
| Data Retained (on Aggregate Basis) |
| For the items below, BST’s Performance Measurement Analysis Platform (PMAP) receives a final computation; therefore, no raw data file is available in PMAP. <ul style="list-style-type: none"> • Month • Call Type (Toll) • Average Speed of Answer |
| Retail Analog/Benchmark |
| Parity by Design See Appendix D |

Revision Date: 02/28/00 (tg)

OPERATOR SERVICES

| |
|--|
| Report/Measurement: |
| OS-3. Speed to Answer Performance/Average Speed to Answer – Directory Assistance (DA) |
| Definition: |
| Measurement of the average time in seconds calls wait before answer by a DA operator. |
| Exclusions: |
| Calls abandoned by customers are not reflected in the average speed to answer but are reflected in the conversion tables where the percent answered within “X” seconds is determined. |
| Business Rules: |
| The call waiting measurement scan starts when the customer enters the queue and ends when a BST representative answers the call. The average speed to answer is determined by measuring and accumulating the seconds of wait time from the entry of a customer into the BST call management system queue until the customer is transferred to a BST representative. No distinction is made between CLEC customers and BST customers. |
| Calculation: |
| The Average Speed to Answer for DA is calculated by using data from monthly system measurement reports taken from the centralized call routing switches. The “total call waiting seconds” is a sub-component of this measure which BST systems calculate by monitoring the number of calls in queue throughout the day multiplied by the time (in seconds) between monitoring events. The “total calls served” is the other sub-component of this measure, which BST systems record as the total number of calls handled by Operator Services DA centers. Since calls abandoned are not reflected in the calculation, the percent answered within the required timeframe is determined by using conversion tables with input for the abandonment rate. |
| Report Structure: |
| <ul style="list-style-type: none"> • Reported for the aggregate of BST and CLECs <ul style="list-style-type: none"> ➤ State |
| Level of Disaggregation: |
| None |
| Data Retained (on Aggregate Basis) |
| For the items below, BST’s Performance Measurement Analysis Platform (PMAP) receives a final computation; therefore, no raw data file is available in PMAP. <ul style="list-style-type: none"> • Month • Call Type (DA) • Average Speed of Answer |
| Retail Analog/Benchmark |
| Parity by Design See Appendix D |

Revision Date: 02/28/00 (tg)

OPERATOR SERVICES

| |
|--|
| Report/Measurement: |
| OS-4. Speed to Answer Performance/Percent Answered within “X” Seconds – Directory Assistance (DA) |
| Definition: |
| Measurement of the percent of DA calls that are answered in less than “X” seconds. The number of seconds represented by “X” is twenty, except where a different regulatory benchmark has been set against the Average Speed to Answer by a State Commission. |
| Exclusions: |
| Calls abandoned by customers are not reflected in the average speed to answer but are reflected in the conversion tables where the percent answered within “X” seconds is determined. |
| Business Rules: |
| The call waiting measurement scan starts when the customer enters the queue and ends when a BST representative answers the call. The average speed to answer is determined by measuring and accumulating the seconds of wait time from the entry of a customer into the BST call management system queue until the customer is transferred to a BST representative. No distinction is made between CLEC customers and BST customers. |
| Calculation: |
| The Percent Answered within “X” Seconds measurement for DA is derived by using the BellCore Statistical Answer Conversion Tables, to convert the Average Speed to Answer measure into a percent of calls answered within “X” seconds. The BellCore Conversion Tables are specific to the defined parameters of work time, number of operators, max queue size and call abandonment rates. |
| Report Structure: |
| <ul style="list-style-type: none"> • Reported for the aggregate of BST and CLECs <ul style="list-style-type: none"> ➤ State |
| Level of Disaggregation: |
| None |
| Data Retained (on Aggregate Basis) |
| For the items below, BST’s Performance Measurement Analysis Platform (PMAP) receives a final computation; therefore, no raw data file is available in PMAP. <ul style="list-style-type: none"> • Month • Call Type (DA) • Average Speed of Answer |
| Retail Analog/Benchmark |
| Parity by Design See Appendix D |

Revision Date: 02/28/00 (tg)

E911

| |
|--|
| Report/Measurement: |
| E-1. Timeliness |
| Definition: |
| Measures the percentage of batch orders for E911 database updates (to CLEC resale and BST retail records) processed successfully within a 24-hour period. |
| Exclusions: |
| <ul style="list-style-type: none"> • Any resale order canceled by a CLEC • Facilities-based CLEC orders |
| Business Rules: |
| The 24-hour processing period is calculated based on the date and time processing starts on the batch orders and the date and time processing stops on the batch orders. Mechanical processing starts when SCC (BST's E911 vendor) receives E911 files containing batch orders extracted from BST's Service Order Communication System (SOCS). Processing stops when SCC loads the individual records to the E911 database. No distinctions are made between CLEC resale records and BST retail records. |
| Calculation: |
| $E911 \text{ Timeliness} = \frac{\Sigma (\text{Number of batch orders processed within 24 hours})}{\text{Total number of batch orders submitted}} \times 100$ |
| Report Structure: |
| <ul style="list-style-type: none"> • Reported for the aggregate of CLEC resale updates and BST retail updates <ul style="list-style-type: none"> ➢ State ➢ Region |
| Levels of Disaggregation: |
| None |
| Data Retained |
| <ul style="list-style-type: none"> • Report month • Aggregate data |
| Retail Analog/Benchmark |
| Parity by Design See Appendix D |

Revision Date: 02/28/00 (tg)

E911

| |
|---|
| Report/Measurement: |
| E-2. Accuracy |
| Definition: |
| Measures the individual E911 telephone number (TN) record updates (to CLEC resale and BST retail records) processed successfully for E911 with no errors. |
| Exclusions: |
| <ul style="list-style-type: none"> • Any resale order canceled by a CLEC • Facilities-based CLEC orders |
| Business Rules: |
| Accuracy is based on the number of records processed without error at the conclusion of the processing cycle. Mechanical processing starts when SCC (BST's E911 vendor) receives E911 files containing telephone number (TN) records extracted from BST's Service Order Communication System (SOCS). No distinctions are made between CLEC resale records and BST retail records. |
| Calculation: |
| $\text{E911 Accuracy} = \frac{\sum(\text{Number of record individual updates processed with no errors} \div \text{Total number of individual record updates}) \times 100$ |
| Report Structure: |
| <ul style="list-style-type: none"> • Reported for the aggregate of CLEC resale updates and BST retail updates <ul style="list-style-type: none"> ➢ State ➢ Region |
| Level of Disaggregation: |
| None |
| Data Retained |
| <ul style="list-style-type: none"> • Report month • Aggregate data |
| Retail Analog/Benchmark |
| Parity by Design See Appendix D |

Revision Date: 02/28/00 (tg)

E911

| |
|--|
| Report/Measurement: |
| E-3. Mean Interval |
| Definition: |
| Measures the mean interval processing of E911 batch orders (to update CLEC resale and BST retail records). |
| Exclusions: |
| <ul style="list-style-type: none"> • Any resale order canceled by a CLEC • Facilities-based CLEC orders |
| Business Rules: |
| The processing period is calculated based on the date and time processing starts on the batch orders and the date and time processing stops on the batch orders. Data is posted in 4-hour increments up to and beyond 24 hours. No distinctions are made between CLEC resale records and BST retail records. |
| Calculation: |
| $\text{E911 Mean Interval} = \sum (\text{Date and time of batch order completion} - \text{Date and time of batch order submission}) \div (\text{Number of batch orders completed})$ |
| Report Structure: |
| <ul style="list-style-type: none"> • Reported for the aggregate of CLEC resale updates and BST retail updates <ul style="list-style-type: none"> ➢ State ➢ Region |
| Level of Disaggregation: |
| None |
| Data Retained (on Aggregate Basis) |
| <ul style="list-style-type: none"> • Report month • Aggregate data |
| Retail Analog/Benchmark |
| Parity by Design See Appendix D |

Revision Date: 02/28/00 (tg)

TRUNK GROUP PERFORMANCE

| | |
|--|-------------------------|
| Report/Measurement: | |
| TGP-1. Trunk Group Performance-Aggregate | |
| Definition: | |
| A report of aggregate blocking information for CLEC trunk groups and BellSouth trunk groups. | |
| Exclusions: | |
| <ul style="list-style-type: none"> • Trunk Groups for which valid data is not available for an entire study period • Duplicate trunk group information | |
| Business Rules: | |
| <ul style="list-style-type: none"> • Aggregate blocking results are created using the statistical analysis package and are output into Excel with separate table for each geographic area. • For each geographic area, plots are generated for: a) the monthly blocking by hour for each affecting group (BellSouth or CLEC), and b) the difference between BellSouth blocking data and CLEC blocking data is calculated and plotted. • The TCBH blocking is calculated by determining the monthly averaging blocking for each hour for each trunk. The hour with the highest usage is selected as the TCBH and the blocking for that hour is reported. • Trunk Categorization: This report displays, over a reporting cycle, aggregate, weighted average blocking data for each hour of a day. Therefore, for each reporting cycle, 24 blocking data points are generated for two aggregate groups of selected trunk groups. These groups are CLEC affecting and BellSouth affecting trunk groups. In order to assign trunk groups to each aggregate group, all trunk groups are first assigned to a category. A trunk group's end points and the type of traffic that is transmitted on it define a category. Selected categories of trunk groups are assigned to the aggregate groups to that trunk reports can be generated. The categories to which trunk groups have been assigned for this report are as follows: | |
| CLEC Affecting Categories: | |
| | <u>Point A</u> |
| Category 1: | BellSouth End Office |
| Category 3: | BellSouth End Office |
| Category 4: | BellSouth Local Tandem |
| Category 5: | BellSouth Access Tandem |
| Category 10: | BellSouth End Office |
| Category 16: | BellSouth Tandem |
| | <u>Point B</u> |
| | BellSouth Access Tandem |
| | CLEC Switch |
| | CLEC Switch |
| | CLEC Switch |
| | BellSouth Local Tandem |
| | BellSouth Tandem |
| BellSouth Affecting Category: | |
| | <u>Point A</u> |
| Category 9: | BellSouth End Office |
| | <u>Point B</u> |
| | BellSouth End Office |

TRUNK GROUP PERFORMANCE - (Trunk Group Performance-Aggregate – Continued)

Calculation:

Monthly Weighted Average Blocking:

(Blocking data for each hour X number of valid measurement days within each week) / Σ (Total number of valid measurement days within each week)

| Example: | | <u>Week 1</u> | <u>Week 2</u> | <u>Week 3</u> | <u>Week 4</u> | <u>Monthly</u> |
|----------|----------|---------------|---------------|---------------|---------------|----------------|
| Hour | | | | | | |
| 1 | Blocking | 1% | 0.5% | 2% | 1.5% | 1.8% |
| | # Days | 7 | 7 | 5 | 6 | |
| 2 | Blocking | 0% | 0% | 0.2% | 0.3% | .1% |
| | # Days | 7 | 5 | 5 | 7 | |
| 3 | Blocking | 1% | 1% | 0.5% | 2% | 1.1% |
| | # Days | 7 | 7 | 7 | 7 | |
| 24 | Blocking | 1% | 0.5% | 2% | 1.5% | 1.2% |
| | # Days | 7 | 7 | 5 | 6 | |

The monthly weighted average blocking for hour 1 for a particular trunk group is calculated as follows:

$$\frac{(1 \times 5) + (0.5 \times 5) + (2 \times 4) + (1.5 \times 4)}{(5 + 5 + 4 + 4)} = 1.2\%$$

Aggregate Monthly Blocking:

(Monthly weighted average blocking value for each trunk group) X (number of trunks within each trunk group) / Σ (number of trunks in the aggregate group)

| Example: | Trunk Group | Trunks in Service | Blocking Hour 1 | Blocking Hour 2 | Blocking Hour 3 | Blocking Hour 4 | | Blocking Hour 24 |
|----------|-------------|-------------------|-----------------|-----------------|-----------------|-----------------|-------|------------------|
| | A | 24 | 3% | 0% | 1% | 0% | | 0% |
| | B | 144 | 2% | 0% | 1% | 0.5% | | 0.5% |
| | C | 528 | 0% | 0.5% | 1% | 1% | | 1% |
| | D | 316 | 1% | 0% | 1% | 0.1% | | 0% |
| | E | 940 | 1% | 1% | 4% | 0% | | 0% |
| | Aggregate | | 0.8% | 0.6% | 2.4% | 0.3% | | 0.3% |

The aggregate weighted monthly blocking for hour 1 is calculated as follows:

$$\frac{(3 \times 24) + (2 \times 144) + (0 \times 528) + (1 \times 316) + (1 \times 940)}{(24 + 144 + 528 + 316 + 940)} = 0.8\%$$

The purpose of the Trunk Group Performance Report is to provide trunk blocking measurements on CLEC and BST trunk groups for comparison only. It is not the intent of the report that it be used for network management and/or engineering.

Report Structure:

- CLEC Aggregate
 - State

Level of Disaggregation:

Trunk Group

Data Retained Relating to CLEC Experience

- Report Month
- Total Trunk Groups
- Number of Trunk Groups by CLEC
- Hourly average blocking per trunk group

Data Retained Relating to BST Experience

- Report Month
- Total Trunk Groups
- Aggregate Hourly average blocking

Retail Analog/Benchmark:

Any 2 hour period in 24 hours where CLEC blockage exceeds BST blockage by more than 0.5% = a miss using trunk groups 1, 3, 4, 5, 10, 16 for CLECs and 9 for BST.

Revision Date: 02/28/00 (tm)

TRUNK GROUP PERFORMANCE

| Report/Measurement: | | | | | | | | | | | | | | | | | | | | | |
|---|-------------------------|-------------------------|----------------|-------------|----------------------|-------------------------|-------------|----------------------|-------------|-------------|------------------------|-------------|-------------|-------------------------|-------------|--------------|----------------------|------------------------|--------------|------------------|------------------|
| TGP-2. Trunk Group Performance-CLEC Specific | | | | | | | | | | | | | | | | | | | | | |
| Definition: | | | | | | | | | | | | | | | | | | | | | |
| A report of blocking information for CLEC trunk groups. | | | | | | | | | | | | | | | | | | | | | |
| Exclusions: | | | | | | | | | | | | | | | | | | | | | |
| <ul style="list-style-type: none"> • Trunk Groups for which valid data is not available for an entire study period • Duplicate trunk group information | | | | | | | | | | | | | | | | | | | | | |
| Business Rules: | | | | | | | | | | | | | | | | | | | | | |
| <ul style="list-style-type: none"> • Aggregate blocking results are created using the statistical analysis package and are output into Excel with separate table for each geographic area. • For each geographic area, plots are generated for the monthly blocking by hour • The TCBH blocking is calculated by determining the monthly averaging blocking for each hour for each trunk. The hour with the highest usage is selected as the TCBH and the blocking for that hour is reported. • Trunk Categorization: This report displays, over a reporting cycle, aggregate, weighted average blocking data for each hour of a day. Therefore, for each reporting cycle, 24 blocking data points are generated for CLEC trunk groups. In order to assign trunk groups to the CLEC group, all trunk groups are first assigned to a category. A trunk group's end points and the type of traffic that is transmitted on it define a category. Selected categories of trunk groups are assigned to the aggregate groups to that trunk reports can be generated. The categories to which trunk groups have been assigned for this report are as follows: <p>CLEC Affecting Categories:</p> <table border="0"> <thead> <tr> <th></th> <th style="text-align: center;"><u>Point A</u></th> <th style="text-align: center;"><u>Point B</u></th> </tr> </thead> <tbody> <tr> <td>Category 1:</td> <td>BellSouth End Office</td> <td>BellSouth Access Tandem</td> </tr> <tr> <td>Category 3:</td> <td>BellSouth End Office</td> <td>CLEC Switch</td> </tr> <tr> <td>Category 4:</td> <td>BellSouth Local Tandem</td> <td>CLEC Switch</td> </tr> <tr> <td>Category 5:</td> <td>BellSouth Access Tandem</td> <td>CLEC Switch</td> </tr> <tr> <td>Category 10:</td> <td>BellSouth End Office</td> <td>BellSouth Local Tandem</td> </tr> <tr> <td>Category 16:</td> <td>BellSouth Tandem</td> <td>BellSouth Tandem</td> </tr> </tbody> </table> | | <u>Point A</u> | <u>Point B</u> | Category 1: | BellSouth End Office | BellSouth Access Tandem | Category 3: | BellSouth End Office | CLEC Switch | Category 4: | BellSouth Local Tandem | CLEC Switch | Category 5: | BellSouth Access Tandem | CLEC Switch | Category 10: | BellSouth End Office | BellSouth Local Tandem | Category 16: | BellSouth Tandem | BellSouth Tandem |
| | <u>Point A</u> | <u>Point B</u> | | | | | | | | | | | | | | | | | | | |
| Category 1: | BellSouth End Office | BellSouth Access Tandem | | | | | | | | | | | | | | | | | | | |
| Category 3: | BellSouth End Office | CLEC Switch | | | | | | | | | | | | | | | | | | | |
| Category 4: | BellSouth Local Tandem | CLEC Switch | | | | | | | | | | | | | | | | | | | |
| Category 5: | BellSouth Access Tandem | CLEC Switch | | | | | | | | | | | | | | | | | | | |
| Category 10: | BellSouth End Office | BellSouth Local Tandem | | | | | | | | | | | | | | | | | | | |
| Category 16: | BellSouth Tandem | BellSouth Tandem | | | | | | | | | | | | | | | | | | | |

TRUNK GROUP PERFORMANCE - (Trunk Group Performance-CLEC Specific – Continued)

Calculation:

Monthly Weighted Average Blocking:

(Blocking data for each hour X number of valid measurement days within each week) / Σ (Total number of valid measurement days within each week)

| Example: | | <u>Week 1</u> | <u>Week 2</u> | <u>Week 3</u> | <u>Week 4</u> | <u>Monthly</u> |
|----------|----------|---------------|---------------|---------------|---------------|----------------|
| Hour | | | | | | |
| 1 | Blocking | 1% | 0.5% | 2% | 1.5% | 1.8% |
| | # Days | 7 | 7 | 5 | 6 | |
| 2 | Blocking | 0% | 0% | 0.2% | 0.3% | .1% |
| | # Days | 7 | 5 | 5 | 7 | |
| 3 | Blocking | 1% | 1% | 0.5% | 2% | 1.1% |
| | # Days | 7 | 7 | 7 | 7 | 5 |
| 24 | Blocking | 1% | 0.5% | 2% | 1.5% | 1.2% |
| | # Days | 7 | 7 | 5 | 6 | |

The monthly weighted average blocking for hour 1 for a particular trunk group is calculated as follows:

$$\frac{(1 \times 5) + (0.5 \times 5) + (2 \times 4) + (1.5 \times 4)}{(5 + 5 + 4 + 4)} = 1.2\%$$

Aggregate Monthly Blocking:

(Monthly weighted average blocking value for each trunk group) X (number of trunks within each trunk group) / Σ (number of trunks in the aggregate group)

| Example: | Trunk Group | Trunks in Service | Blocking Hour 1 | Blocking Hour 2 | Blocking Hour 3 | Blocking Hour 4 | | Blocking Hour 24 |
|----------|-------------|-------------------|-----------------|-----------------|-----------------|-----------------|-------|------------------|
| | A | 24 | 3% | 0% | 1% | 0% | | 0% |
| | B | 144 | 2% | 0% | 1% | 0.5% | | 0.5% |
| | C | 528 | 0% | 0.5% | 1% | 1% | | 1% |
| | D | 316 | 1% | 0% | 1% | 0.1% | | 0% |
| | E | 940 | 1% | 1% | 4% | 0% | | 0% |
| | Aggregate | | 0.8% | 0.6% | 2.4% | 0.3% | | 0.3% |

The aggregate weighted monthly blocking for hour 1 is calculated as follows:

$$\frac{(3 \times 24) + (2 \times 144) + (0 \times 528) + (1 \times 316) + (1 \times 940)}{(24 + 144 + 528 + 316 + 940)} = 0.8\%$$

The purpose of the Trunk Group Performance Report is to provide trunk blocking measurements on CLEC and BST trunk groups for comparison only. It is not the intent of the report that it be used for network management and/or engineering.

Report Structure:

- CLEC Specific
- Trunk Group

Level of Disaggregation:

Trunk Group

Data Retained Relating to CLEC Experience

- Report Month
- Total Trunk Groups
- Number of Trunk Groups by CLEC
- Hourly average blocking per trunk group

Data Retained Relating to BST Experience

- Report Month
- Total Trunk Groups
- Aggregate Hourly average blocking

Retail Analog/Benchmark:

Any 2 hour period in 24 hours where CLEC blockage exceeds BST blockage by more than 0.5% = a miss using trunk groups 1, 3, 4, 5, 10, 16 for CLECs and 9 for BST.

Revision Date: 02/28/00 (tm)

TRUNK GROUP PERFORMANCE

| | |
|---|---|
| Report/Measurement: | |
| TGP-3. Trunk Group Service Report | |
| Definition: | |
| A report of the percent blocking above the Measured Blocking Threshold (MBT) on all final trunk groups between CLEC Points of Termination and BST end offices or tandems. | |
| Exclusions: | |
| <ul style="list-style-type: none"> • Trunk groups for which valid traffic data is not available • High use trunk groups | |
| Business Rules: | |
| Traffic trunking data measurements are validated and processed by the Total Network Data System/Trunking (TNDS/TK), a Telcordia (BellCore) supported application, on an hourly basis for Average Business Days (Monday through Friday). The traffic load sets, including offered load and observed blocking ratio (calls blocked divided by calls attempted), are averaged for a 20 day period, and the busy hour is selected. The busy hour average data for each trunk group is captured for reporting purposes. Although all trunk groups are available for reporting, the report highlight those trunk groups with blocking greater than the Measured Blocking Threshold (MBT) and the number of consecutive monthly reports that the trunk group blocking has exceeded the MBT. The MBT for CTTG is 2% and the MBT for all other trunk groups is 3%. | |
| Calculation: | |
| Measured blocking = (Total number of blocked calls) / (Total number of attempted calls) X 100 | |
| Report Structure: | |
| <ul style="list-style-type: none"> • BST Aggregate <ul style="list-style-type: none"> ➢ CTTG ➢ Local • CLEC Aggregate <ul style="list-style-type: none"> ➢ BST Administered CLEC Trunk ➢ CLEC Administered CLEC Trunk • CLEC Specific <ul style="list-style-type: none"> ➢ BST Administered CLEC Trunk ➢ CLEC Administered CLEC Trunk | |
| Level of Disaggregation: | |
| State | |
| Data Retained Relating to CLEC Experience | Data Retained Relating to BST Experience |
| <ul style="list-style-type: none"> • Report month • Total trunk groups • Total trunk groups for which data is available • Trunk groups with blocking greater than the MBT • Percent of trunk groups with blocking greater than the MBT | <ul style="list-style-type: none"> • Report month • Total trunk groups • Total trunk groups for which data is available • Trunk groups with blocking greater than the MBT • Percent of trunk groups with blocking greater than the MBT |
| Retail Analog/Benchmark: | |
| CLEC Trunk Blockage/BST Trunk Blockage See Appendix D | |

Revision Date: 02/28/00 (tm)

TRUNK GROUP PERFORMANCE

| | |
|---|---|
| Report/Measurement: | |
| TGP-4. Trunk Group Service Detail | |
| Definition: | |
| A detailed list of all final trunk groups between CLEC Points of Presence and BST end offices or tandems, and the actual blocking performance when the blocking exceeds the Measured Blocking Threshold (MBT) for the trunk groups. | |
| Exclusions: | |
| <ul style="list-style-type: none"> • Trunk groups for which valid traffic data is not available • High use trunk groups | |
| Business Rules: | |
| Traffic trunking data measurements are validated and processed by the Total Network Data System/Trunking (TNDS/TK), a Telcordia (Bellcore) supported application, on an hourly basis for Average Business Days (Monday through Friday). The traffic load sets, including offered load and observed blocking ratio (calls blocked divided by calls attempted), are averaged for a 20 day period, and the busy hour is selected. The busy hour average data for each trunk group is captured for reporting purposes. Although all trunk groups are available for reporting, the report highlight those trunk groups with blocking greater than the Measured Blocking Threshold (MBT) and the number of consecutive monthly reports that the trunk group blocking has exceeded the MBT. The MBT for CTTG is 2% and the MBT for all other trunk groups is 3%. | |
| Calculation: | |
| Measured Blocking = (Total number of blocked calls) / (Total number of attempted calls) X 100 | |
| Report Structure: | |
| <ul style="list-style-type: none"> • BST Specific <ul style="list-style-type: none"> ➢ Traffic Identity ➢ TGSN ➢ Tandem ➢ End Office ➢ Description ➢ Observed Blocking ➢ Busy Hour ➢ Number Trunks ➢ Valid study days ➢ Number reports ➢ Remarks | <ul style="list-style-type: none"> • CLEC Specific <ul style="list-style-type: none"> ➢ Traffic Identity ➢ TGSN ➢ Tandem ➢ CLEC POT ➢ Description ➢ Observed Blocking ➢ Busy Hour ➢ Number Trunks ➢ Valid study days ➢ Number reports ➢ Remarks |
| Level of Disaggregation: | |
| State | |
| Data Retained Relating to CLEC Experience | Data Retained Relating to BST Experience |
| <ul style="list-style-type: none"> • Report month • Total trunk groups • Total trunk groups for which data is available • Trunk groups with blocking greater than the MBT • Percent of trunk groups with blocking greater than the MBT • Traffic identity, TGSN, end points, description, busy hour, valid study days, number reports | <ul style="list-style-type: none"> • Report month • Total trunk groups • Total trunk groups for which data is available • Trunk groups with blocking greater than the MBT • Percent of trunk groups with blocking greater than the MBT • Traffic identity, TGSN, end points, description, busy hour, valid study days, number reports |
| Retail Analog/Benchmark: | |
| CLEC Trunk Blockage/BST Blockage See Appendix D | |

Revision Date: 02/28/00 (tm)

COLLOCATION

| |
|---|
| Report/Measurement: |
| C-1. Average Response Time |
| Definition: |
| Measures the average time (counted in business days) from the receipt of a complete and accurate collocation application (including receipt of application fees) to the date BellSouth responds in writing. |
| Exclusions: |
| <ul style="list-style-type: none"> • Requests to augment previously completed arrangements • Any application cancelled by the CLEC |
| Business Rules: |
| The clock starts on the date that BST receives a complete and accurate collocation application accompanied by the appropriate application fee. The clock stops on the date that BST returns a response. The clock will restart upon receipt of changes to the original application request. |
| Calculation: |
| Average Response Time = $\Sigma(\text{Request Response Date}) - (\text{Request Submission Date}) / \text{Count of Responses Returned within Reporting Period.}$ |
| Report Structure: |
| <ul style="list-style-type: none"> • Individual CLEC (alias) aggregate • Aggregate of all CLECs |
| Level of Disaggregation: |
| <ul style="list-style-type: none"> • State, Region and further geographic disaggregation as required by State Commission Order (e.g. Metropolitan Service Area – MSA) • Virtual • Physical |
| Data Retained: |
| <ul style="list-style-type: none"> • Report period • Aggregate data |
| Retail Analog/Benchmark: |
| See Appendix D |

Revision Date: 01/27/00 (tg)

COLLOCATION

| |
|---|
| Report/Measurement: |
| C-2. Average Arrangement Time |
| Definition: |
| Measures the average time from the receipt of a complete and accurate Bona Fide firm order (including receipt of appropriate fee) to the date BST completes the collocation arrangement. |
| Exclusions: |
| <ul style="list-style-type: none"> • Any Bona Fide firm order cancelled by the CLEC • Bona Fide firm orders to augment previously completed arrangements • Time for BST to obtain permits • Time during which the collocation contract is being negotiated |
| Business Rules: |
| The clock starts on the date that BST receives a complete and accurate Bona Fide firm order accompanied by the appropriate fee. The clock stops upon submission of the permit request and restarts upon receipt of the approved permit. Changes (affecting the provisioning interval or capital expenditures) that are submitted while provisioning is in progress may alter the completion date. The clock stops on the date that BST completes the collocation arrangement. |
| Calculation: |
| Average Arrangement Time = $\Sigma(\text{Date Collocation Arrangement is Complete}) - (\text{Date Order for Collocation Arrangement Submitted}) / \text{Total Number of Collocation Arrangements Completed during Reporting Period.}$ |
| Report Structure: |
| <ul style="list-style-type: none"> • Individual CLEC (alias) aggregate • Aggregate of all CLECs |
| Level of Disaggregation: |
| <ul style="list-style-type: none"> • State, Region and further geographic disaggregation as required by State Commission Order (e.g. Metropolitan Service Area – MSA) • Virtual • Physical |
| Data Retained: |
| <ul style="list-style-type: none"> • Report period • Aggregate data |
| Retail Analog/Benchmark: |
| See Appendix D |

Revision Date: 01/27/00 (tg)

COLLOCATION

| |
|--|
| Report/Measurement: |
| C-3. Percent of Due Dates Missed |
| Definition: |
| Measures the percent of missed due dates for collocation arrangements. |
| Exclusions: |
| <ul style="list-style-type: none"> • Any Bona Fide firm order cancelled by the CLEC • Bona Fide firm orders to augment previously completed arrangements • Time for BST to obtain permits • Time during which the collocation contract is being negotiated |
| Business Rules: |
| The clock starts on the date that BST receives a complete and accurate Bona Fide firm order accompanied by the appropriate fee. The clock stops on the date that BST completes the collocation arrangement. |
| Calculation: |
| $\% \text{ of Due Dates Missed} = \frac{\Sigma (\text{Number of Orders not completed w/i ILEC Committed Due Date during Reporting Period})}{\text{Number of Orders Completed in Reporting Period}} \times 100$ |
| Report Structure: |
| <ul style="list-style-type: none"> • Individual CLEC (alias) aggregate • Aggregate of all CLECs |
| Level of Disaggregation: |
| <ul style="list-style-type: none"> • State, Region and further geographic disaggregation as required by State Commission Order (e.g. Metropolitan Service Area-MSA) • Virtual • Physical |
| Data Retained: |
| <ul style="list-style-type: none"> • Report period • Aggregate data |
| Retail Analog/Benchmark: |
| 90% ≤ Commit Date |

Revision Date: 01/27/00 (tg)

Appendix A: Reporting Scope*

| Standard Service Groupings | |
|----------------------------|---|
| | <p><u>Pre-Order, Ordering</u></p> <ul style="list-style-type: none"> ➤ Resale Residence ➤ Resale Business ➤ Resale Special ➤ Local Interconnection Trunks ➤ UNE ➤ UNE - Loops w/LNP <p><u>Provisioning</u></p> <ul style="list-style-type: none"> ➤ UNE Non-Design ➤ UNE Design ➤ Local Interconnection Trunks ➤ Resale Residence ➤ Resale Business ➤ Resale Design ➤ BST Trunks ➤ BST Residence Retail ➤ BST Business Retail ➤ BST Design Retail <p><u>Maintenance and Repair</u></p> <ul style="list-style-type: none"> ➤ Local Interconnection Trunks ➤ UNE Non-Design ➤ UNE Design ➤ Resale Residence ➤ Resale Business ➤ Resale Design ➤ BST Interconnection Trunks ➤ BST Residence Retail ➤ BST Business Retail ➤ BST Design Retail <p><u>Local Interconnection Trunk Group Blockage</u></p> <ul style="list-style-type: none"> ➤ BST CTTG Trunk Groups ➤ CLEC Trunk Groups |

Appendix A: Reporting Scope*

| | |
|--|--|
| | |
| <p>Standard Service Order Activities</p> <p><i>These are the generic BST/CLEC service order activities which are included in the Pre-Ordering, Ordering, and Provisioning sections of this document. It is not meant to indicate specific reporting categories.</i></p> | <ul style="list-style-type: none"> ➤ New Service Installations ➤ Service Migrations Without Changes ➤ Service Migrations With Changes ➤ Move and Change Activities ➤ Service Disconnects (Unless noted otherwise) |
| <p>Pre-Ordering Query Types:</p> <p>Maintenance Query Types:</p> | <ul style="list-style-type: none"> ➤ Address ➤ Telephone Number ➤ Appointment Scheduling ➤ Customer Service Record ➤ Feature Availability |
| <p>Report Levels</p> | <ul style="list-style-type: none"> ➤ CLEC RESH ➤ CLEC MSA ➤ CLEC State ➤ CLEC Region ➤ Aggregate CLEC State ➤ Aggregate CLEC Region ➤ BST State ➤ BST Region |

* Scope is report, data source and system dependent, and, therefore, will differ with each report.

Appendix B: Glossary of Acronyms and Terms

| | | |
|----------|--|--|
| A | <p>ACD</p> <p>AGGREGATE</p> <p>ASR</p> <p>ATLAS</p> <p>ATLASTN</p> <p>AUTO CLARIFICATION</p> | <p>Automatic Call Distributor - A service that provides status monitoring of agents in a call center and routes high volume incoming telephone calls to available agents while collecting management information on both callers and attendants.</p> <p>Sum total of all items in like category, e.g. CLEC aggregate equals the sum total of all CLECs' data for a given reporting level.</p> <p>Access Service Request - A request for access service terminating delivery of carrier traffic into a Local Exchange Carrier's network.</p> <p>Application for Telephone Number Load Administration System - The BellSouth Operations System used to administer the pool of available telephone numbers and to reserve selected numbers from the pool for use on pending service requests/service orders.</p> <p>ATLAS software contract for Telephone Number</p> <p>The number of LSRs that were electronically rejected from LESOG and electronically returned to the CLEC for correction.</p> |
| B | <p>BILLING</p> <p>BOCRIS</p> <p>BRC</p> <p>BST</p> | <p>The process and functions by which billing data is collected and by which account information is processed in order to render accurate and timely billing.</p> <p>Business Office Customer Record Information System - A front-end presentation manager used by BellSouth organizations to access the CRIS database.</p> <p>Business Repair Center – The BellSouth Business Systems trouble receipt center which serves large business and CLEC customers.</p> <p>BellSouth Telecommunications, Inc.</p> |
| C | <p>CKTID</p> <p>CLEC</p> <p>CMDS</p> <p>COFFI</p> | <p>A unique identifier for elements combined in a service configuration</p> <p>Competitive Local Exchange Carrier</p> <p>Centralized Message Distribution System - BellCore administered national system used to transfer specially formatted messages among companies.</p> <p>Central Office Feature File Interface - A BellSouth Operations System database which maintains Universal Service Order Code (USOC) information based on current tariffs.</p> |

Appendix B: Glossary of Acronyms and Terms – Continued

| | | |
|----------|--------------------------------|--|
| C | COFIUSOC | COFFI software contract for feature/service information |
| | CRIS | Customer Record Information System - The BellSouth proprietary corporate database and billing system for non-access customers and services. |
| | CRSACCTS | CRIS software contract for CSR information |
| | CSR | Customer Service Record |
| | CTTG | Common Transport Trunk Group - Final trunk groups between BST & Independent end offices and the BST access tandems. |
| D | DESIGN | Design Service is defined as any Special or Plain Old Telephone Service Order which requires BellSouth Design Engineering Activities |
| | DISPOSITION & CAUSE | Types of trouble conditions, e.g. No Trouble Found, Central Office Equipment, Customer Premises Equipment, etc. |
| | DLETH | Display Lengthy Trouble History - A history report that gives all activity on a line record for trouble reports in LMOS |
| | DLR | Detail Line Record - All the basic information maintained on a line record in LMOS, e.g. name, address, facilities, features etc. |
| | DOE | Direct Order Entry System - An internal BellSouth service order entry system used by BellSouth Service Representatives to input business service orders in BellSouth format. |
| | DSAP | DOE (Direct Order Entry) Support Application - The BellSouth Operations System which assists a Service Representative or similar carrier agent in negotiating service provisioning commitments for non-designed services and UNEs. |
| | DSAPDDI | DSAP software contract for schedule information |
| E | E911 | Provides callers access to the applicable emergency services bureau by dialing a 3-digit universal telephone number. |
| | EDI | Electronic Data Interchange - The computer-to-computer exchange of inter and/or intra company business documents in a public standard format. |
| F | FATAL REJECT | The number of LSRs that were electronically rejected from LEO, which checks to see if the LSR has all the required fields correctly populated |
| | FLOW-THROUGH | In the context of this document, LSRs submitted electronically via the CLEC mechanized ordering process that flow through to the BST OSS without manual or human intervention. |
| | FOC | Firm Order Confirmation - A notification returned to the CLEC confirming that the LSR has been received and accepted, including the specified commitment date. |

Appendix B: Glossary of Acronyms and Terms - Continued

| | | |
|----------|---------------------------------|---|
| G | | |
| H | HAL | “Hands Off” Assignment Logic - Front end access and error resolution logic used in interfacing BellSouth Operations Systems such as ATLAS, BOCRIS, LMOS, PSIMS, RSAG and SOCS. |
| | HALCRIS | HAL software contract for CSR information |
| I | ISDN | Integrated Services Digital Network |
| K | | |
| L | LCSC | Local Carrier Service Center - The BellSouth center which is dedicated to handling CLEC LSRs, ASRs, and Preordering transactions along with associated expedite requests and escalations. |
| | LEGACY SYSTEM | Term used to refer to BellSouth Operations Support Systems (see OSS) |
| | LENS | Local Exchange Negotiation System - The BellSouth LAN/web server/OS application developed to provide both preordering and ordering electronic interface functions for CLECs. |
| | LEO | Local Exchange Ordering - A BellSouth system which accepts the output of EDI, applies edit and formatting checks, and reformats the Local Service Requests in BellSouth Service Order format. |
| | LESOG | Local Exchange Service Order Generator - A BellSouth system which accepts the service order output of LEO and enters the Service Order into the Service Order Control System using terminal emulation technology. |
| | LMOS | Loop Maintenance Operations System - A BellSouth Operations System that stores the assignment and selected account information for use by downstream OSS and BellSouth personnel during provisioning and maintenance activities. |
| | LMOS HOST | LMOS host computer |
| | LMOSupd | LMOS updates |
| | LNP | Local Number Portability - In the context of this document, the capability for a subscriber to retain his current telephone number as he transfers to a different local service provider. |
| | LOOPS | Transmission paths from the central office to the customer premises. |
| | LSR | Local Service Request – A request for local resale service or unbundled network elements from a CLEC. |
| M | MAINTENANCE & REPAIR | The process and function by which trouble reports are passed to BellSouth and by which the related service problems are resolved. |
| | MARCH | A BellSouth Operations System which accepts service orders, interprets the coding contained in the service order image, and constructs the specific switching system Recent Change command messages for input into end office switches. |

Appendix B: Glossary of Acronyms and Terms – Continued

| | | |
|----------|-----------------------|--|
| N | NC | “No Circuits” - All circuits busy announcement |
| O | OASIS | Obtain Availability Services Information System - A BellSouth front-end processor, which acts as an interface between COFFI and RNS. This system takes the USOCs in COFFI and translates them to English for display in RNS. |
| | OASISBSN | OASIS software contract for feature/service |
| | OASISCAR | OASIS software contract for feature/service |
| | OASISLPC | OASIS software contract for feature/service |
| | OASISMTN | OASIS software contract for feature/service |
| | OASISNET | OASIS software contract for feature/service |
| | OASISOCP | OASIS software contract for feature/service |
| | ORDERING | The process and functions by which resale services or unbundled network elements are ordered from BellSouth as well as the process by which an LSR or ASR is placed with BellSouth. |
| | OSPCM | Outside Plant Contract Management System - Provides Scheduling Information. |
| | OSS | Operations Support System - A support system or database which is used to mechanize the flow or performance of work. The term is used to refer to the overall system consisting of hardware complex, computer operating system(s), and application which is used to provide the support functions. |
| | OUT OF SERVICE | Customer has no dial tone and cannot call out. |
| P | POTS | Plain Old Telephone Service |
| | PREDICTOR | The BellSouth Operations system which is used to administer proactive maintenance and rehabilitation activities on outside plant facilities, provide access to selected work groups (e.g. RRC & BRC) to Mechanized Loop Testing and switching system I/O ports, and provide certain information regarding the attributes and capabilities of outside plant facilities. |
| | PREORDERING | The process and functions by which vital information is obtained, verified, or validated prior to placing a service request. |
| | PROVISIONING | The process and functions by which necessary work is performed to activate a service requested via an LSR or ASR and to initiate the proper billing and accounting functions. |
| | PSIMS | Product/Service Inventory Management System - A BellSouth database Operations System which contains availability information on switching system features and capabilities and on BellSouth service availability. This database is used to verify the availability of a feature or service in an NXX prior to making a commitment to the customer. |
| | PSIMSORB | PSIMS software contract for feature/service |

Appendix B: Glossary of Acronyms and Terms – Continued

| | | |
|----------|-----------------------------|---|
| Q | | |
| R | RNS | Regional Negotiation System - An internal BellSouth service order entry system used by BellSouth Consumer Services to input service orders in BellSouth format. |
| | RRC | Residence Repair Center - The BellSouth Consumer Services trouble receipt center which serves residential customers. |
| | RSAG | Regional Street Address Guide - The BellSouth database, which contains street addresses validated to be accurate with state and local governments. RSAG software contract for address search |
| | RSAGADDR | RSAG software contract for telephone number search |
| | RSAGTN | |
| S | SOCS | Service Order Control System - The BellSouth Operations System which routes service order images among BellSouth drop points and BellSouth Operations Systems during the service provisioning process. |
| | SOIR | Service Order Interface Record - any change effecting activity to a customer account by service order that impacts 911/E911. |
| T | TAFI | Trouble Analysis Facilitation Interface - The BellSouth Operations System that supports trouble receipt center personnel in taking and handling customer trouble reports. |
| | TAG | Telecommunications Access Gateway – TAG was designed to provide an electronic interface, or machine-to-machine interface for the bi-directional flow of information between BellSouth’s OSSs and participating CLECs. |
| | TN | Telephone Number |
| | TOTAL MANUAL FALLOUT | The number of LSRs which are entered electronically but require manual entering into a service order generator. |
| U | UNE | Unbundled Network Element |
| V | | |
| W | WTN | A unique identifier for elements combined in a service configuration |
| X | | |
| Y | | |
| Z | | |
| Σ | | Sum of: |

Appendix C

BELLSOUTH'S AUDIT POLICY:

BellSouth currently provides many CLECs with certain audit rights as a part of their individual interconnection agreements. However, it is not reasonable for BellSouth to undergo an audit of the SQM for every CLEC with which it has a contract. BellSouth has developed a proposed Audit Plan for use by the parties to an audit. If requested by a Public Service Commission or by a CLEC exercising contractual audit rights, BellSouth will agree to undergo a comprehensive audit of the aggregate level reports for both BellSouth and the CLEC(s) for each of the next five (5) years (2000 – 2005), to be conducted by an independent third party. The results of that audit will be made available to all the parties subject to proper safeguards to protect proprietary information. This aggregate level audit includes the following specifications:

1. The cost shall be borne 50% by BellSouth and 50% by the CLEC or CLECs.
2. The independent third party auditor shall be selected with input from BellSouth, the PSC, if applicable, and the CLEC(s).
3. BellSouth, the PSC and the CLEC(s) shall jointly determine the scope of the audit.

BellSouth reserves the right to make changes to this audit policy as growth and changes in the industry dictate.

| APPENDIX D | | | | |
|-------------------------------|--|-------------------------------------|------------------------------------|-------------------|
| Analogs and Benchmarks | | | | |
| BST SQM Category | MEASURES AND SUB-METRICS | RESALE Retail Analogue | UNES Retail Analogue | Benchmark* |
| Pre-Ordering | <u>Percent Response Received within "X" seconds</u> | | Parity w/ retail where applicable. | |
| | <u>OSS Interface Availability</u> | | | 99.5% |
| Ordering | <u>Percent Flow-Through Service Request</u> <ul style="list-style-type: none"> • Residence • Business • UNE | | | 90% 80% 80% |
| | <u>Percent Rejected Service Request</u> | Diagnostic | | Diagnostic. |
| | Reject Interval (Mechanized) | UD | UD | 95% within 1 hrs |
| | • Reject Interval (Non-Mechanized and Partially Mechanized) | UD | UD | 85% < 24 hrs |
| | Firm Order Confirmation Timeliness (Mechanized) (Non-Mechanized and Partially Mechanized) | UD | UD | 95% within 4 hrs |
| | <u>Speed of Answer in Ordering Center</u> | X | X | 85% <48 Hrs |
| Provisioning | <u>Mean Held Order Interval</u> | | | |
| | • Resale Residence | X | | |
| | • Resale Business | X | | |
| | • Resale Design | X | | |
| | • Resale PBX | X | | |
| | • Resale Centrex | X | | |
| | • Resale IDSN | X | | |
| | • UNE Loop and Port Combos | | Retail Residence and Business | |
| | • UNE 2w Loop with NP – Non-Design | | Retail Residence and Business | |
| | • UNE 2w Loop without NP – Non-Design | | Retail Residence and Business | |
| | • UNE Loop Other with NP Non-Design | | Retail Residence and Business | |
| | • UNE Loop Other without NP Non-Design | | Retail Residence and Business | |
| | • UNE Other Non Design | | Retail Residence and Business | |
| | • UNE 2w Loop with NP – Design | | Retail Residence and Business | |
| | • UNE 2w Loop without NP – Design | | Retail Residence and Business | |
| | • UNE Loop Other with NP – Design | | Retail Design | |

| APPENDIX D Analog and Benchmarks | | | | |
|---|---|---------------------------------------|---------------------------------|-------------------------------|
| BST SQM Category | MEASURES AND SUB-METRICS | RESALE Retail Analogue | UNES Retail Analogue | Benchmark* |
| | • UNE Loop Other without NP - Design | | | Retail Design |
| | • UNE Other Design | | | Retail Design |
| | • Local Interconnection Trunks | X | | |
| | Average Jeopardy Notice Interval (Mechanized) | | | |
| | • Resale Residence | | | 95% >=24 Hrs. |
| | • Resale Business | | | 95% >=24 Hrs. |
| | • Resale Design | | | 95% >=24 Hrs. |
| | • Resale PBX | | | 95% >=24 Hrs. |
| | • Resale Centrex | | | 95% >=24 Hrs. |
| | • Resale IDSN | | | 95% >=24 Hrs. |
| | • UNE Loop and Port Combos | | | 95% >=24 Hrs. |
| | • UNE 2w Loop with NP – Non-Design | | | 95% >=24 Hrs. |
| | • UNE 2w Loop without NP – Non-Design | | | 95% >=24 Hrs. |
| | • UNE Loop Other with NP Non-Design | | | 95% >=24 Hrs. |
| | • UNE Loop Other without NP Non-Design | | | 95% >=24 Hrs. |
| | • UNE Other Non Design | | | 95% >=24 Hrs. |
| | • UNE 2w Loop with NP – Design | | | 95% >=24 Hrs. |
| | • UNE 2w Loop without NP – Design | | | 95% >=24 Hrs. |
| | • UNE Loop Other with NP – Design | | | 95% >=24 Hrs. |
| | • UNE Loop Other without NP - Design | | | 95% >=24 Hrs. |
| | • UNE Other Design | | | 95% >=24 Hrs. |
| | • Local Interconnection Trunks | | | 95% >=24 Hrs. |
| | % of Orders given jeopardy notice (Mechanized) | | | |
| | • Resale Residence | X | | |
| | • Resale Business | X | | |
| | • Resale Design | X | | |
| | • Resale PBX | X | | |
| | • Resale Centrex | X | | |
| | • Resale IDSN | X | | |
| | • UNE Loop and Port Combos | | | Retail Residence and Business |
| | • UNE 2w Loop with NP – Non-Design | | | Retail Residence and Business |
| | • UNE 2w Loop without NP – Non-Design | | | Retail Residence and Business |
| | • UNE Loop Other with NP Non-Design | | | Retail Residence and Business |

| APPENDIX D | | | | |
|-------------------------------|--|-------------------------------------|--------------------------------|-------------------|
| Analogs and Benchmarks | | | | |
| BST SQM Category | MEASURES AND SUB-METRICS | RESALE Retail Analogue | UNES Retail Analogue | Benchmark* |
| | • UNE Loop Other without NP Non-Design | | Retail Residence and Business | |
| | • UNE Other Non Design | | Retail Residence and Business | |
| | • UNE 2w Loop with NP – Design | | Retail Residence and Business | |
| | • UNE 2w Loop without NP – Design | | Retail Residence and Business | |
| | • UNE Loop Other with NP – Design | | Retail Design | |
| | • UNE Loop Other without NP - Design | | Retail Design | |
| | • UNE Other Design | | Retail Design | |
| | • Local Interconnection Trunks | X | | |
| | <u>Percent Missed Installation Appointments</u> | | | |
| | • Resale Residence | X | | |
| | • Resale Business | X | | |
| | • Resale Design | X | | |
| | • Resale PBX | X | | |
| | • Resale Centrex | X | | |
| | • Resale IDSN | X | | |
| | • UNE Loop and Port Combos | | Retail Residence and Business | |
| | • UNE 2w Loop with NP – Non-Design | | Retail Residence and Business | |
| | • UNE 2w Loop without NP – Non-Design | | Retail Residence and Business | |
| | • UNE Loop Other with NP Non-Design | | Retail Residence and Business | |
| | • UNE Loop Other without NP Non-Design | | Retail Residence and Business | |
| | • UNE Other Non Design | | Retail Residence and Business | |
| | • UNE 2w Loop with NP – Design | | Retail Residence and Business | |
| | • UNE 2w Loop without NP – Design | | Retail Residence and Business | |
| | • UNE Loop Other with NP – Design | | Retail Design | |
| | • UNE Loop Other without NP – Design | | Retail Design | |
| | • UNE Other Design | | Retail Design | |
| | • Local Interconnection Trunks | X | | |
| | <u>Order Completion Interval</u> | | | |
| | • Resale Residence | X | | |
| | • Resale Business | X | | |
| | • Resale Design | X | | |
| | • Resale PBX | X | | |
| | • Resale Centrex | X | | |

| APPENDIX D Analog and Benchmarks | | | | |
|---|---|---------------------------------------|---------------------------------|-------------------|
| BST SQM Category | MEASURES AND SUB-METRICS | RESALE Retail Analogue | UNES Retail Analogue | Benchmark* |
| | • Resale IDSN | X | | |
| | • UNE Loop and Port Combos | | Retail Residence and Business | |
| | • UNE 2w Loop with NP – Non-Design | | Retail Residence and Business | |
| | • UNE 2w Loop without NP – Non-Design | | Retail Residence and Business | |
| | • UNE Loop Other with NP Non-Design | | Retail Residence and Business | |
| | • UNE Loop Other without NP Non-Design | | Retail Residence and Business | |
| | • UNE Other Non Design | | Retail Residence and Business | |
| | • UNE 2w Loop with NP – Design | | Retail Residence and Business | |
| | • UNE 2w Loop without NP – Design | | Retail Residence and Business | |
| | • UNE Loop Other with NP – Design | | Retail Design | |
| | • UNE Loop Other without NP - Design | | Retail Design | |
| | • UNE Other Design | | Retail Design | |
| | • Local Interconnection Trunks | X | | |
| | <u>Average Completion Notice Interval – Resale POTS (Mech)</u> | | | |
| | • Resale Residence | X | | |
| | • Resale Business | X | | |
| | • Resale Design | X | | |
| | • Resale PBX | X | | |
| | • Resale Centrex | X | | |
| | • Resale IDSN | X | | |
| | • UNE Loop and Port Combos | | Retail Residence and Business | |
| | • UNE 2w Loop with NP – Non-Design | | Retail Residence and Business | |
| | • UNE 2w Loop without NP – Non-Design | | Retail Residence and Business | |
| | • UNE Loop Other with NP Non-Design | | Retail Residence and Business | |
| | • UNE Loop Other without NP Non-Design | | Retail Residence and Business | |
| | • UNE Other Non Design | | Retail Residence and Business | |
| | • UNE 2w Loop with NP – Design | | Retail Residence and Business | |
| | • UNE 2w Loop without NP – Design | | Retail Residence and Business | |
| | • UNE Loop Other with NP – Design | | Retail Design | |
| | • UNE Loop Other without NP - Design | | Retail Design | |
| | • UNE Other Design | | Retail Design | |
| | • Local Interconnection Trunks | X | | |
| | <u>Percent Provisioning Troubles within 30 Days</u> | | | |

| APPENDIX D Analog and Benchmarks | | | | |
|---|--|---------------------------------------|---------------------------------|-------------------|
| BST SQM Category | MEASURES AND SUB-METRICS | RESALE Retail Analogue | UNES Retail Analogue | Benchmark* |
| | • Resale Residence | X | | |
| | • Resale Business | X | | |
| | • Resale Design | X | | |
| | • Resale PBX | X | | |
| | • Resale Centrex | X | | |
| | • Resale IDSN | X | | |
| | • UNE Loop and Port Combos | | Retail Residence and Business | |
| | • UNE 2w Loop with NP – Non-Design | | Retail Residence and Business | |
| | • UNE 2w Loop without NP – Non-Design | | Retail Residence and Business | |
| | • UNE Loop Other with NP Non-Design | | Retail Residence and Business | |
| | • UNE Loop Other without NP Non-Design | | Retail Residence and Business | |
| | • UNE Other Non Design | | Retail Residence and Business | |
| | • UNE 2w Loop with NP – Design | | Retail Residence and Business | |
| | • UNE 2w Loop without NP – Design | | Retail Residence and Business | |
| | • UNE Loop Other with NP – Design | | Retail Design | |
| | • UNE Loop Other without NP - Design | | Retail Design | |
| | • UNE Other Design | | Retail Design | |
| | • Local Interconnection Trunks | X | | |
| | <u>Total Service Order Cycle Time</u> | Diag. | Diagnostic | Diagnostic |
| Maintenance | <u>Customer Trouble Report Rate</u> | | | |
| | • Resale Residence | X | | |
| | • Resale Business | X | | |
| | • Resale Design | X | | |
| | • Resale PBX | X | | |
| | • Resale Centrex | X | | |
| | • Resale IDSN | X | | |
| | • UNE Loop and Port Combos | | Retail Residence and Business | |
| | • UNE 2w Loop – Non-Design | | Retail Residence and Business | |
| | • UNE Loop Other - Non-Design | | Retail Residence and Business | |
| | • UNE Other Non Design | | Retail Residence and Business | |
| | • UNE 2w Loop – Design | | Retail Residence and Business | |
| | • UNE Loop Other – Design | | Retail Design | |
| | • UNE Other Design | | Retail Design | |

| APPENDIX D Analog and Benchmarks | | | | |
|---|--|---------------------------------------|---------------------------------|-------------------|
| BST SQM Category | MEASURES AND SUB-METRICS | RESALE Retail Analogue | UNES Retail Analogue | Benchmark* |
| | • Local Interconnection Trunks | X | | |
| | <u>Percent Missed Repair Appointments</u> | | | |
| | • Resale Residence | X | | |
| | • Resale Business | X | | |
| | • Resale Design | X | | |
| | • Resale PBX | X | | |
| | • Resale Centrex | X | | |
| | • Resale IDSN | X | | |
| | • UNE Loop and Port Combos | | Retail Residence and Business | |
| | • UNE 2w Loop – Non-Design | | Retail Residence and Business | |
| | • UNE Loop Other - Non-Design | | Retail Residence and Business | |
| | • UNE Other Non Design | | Retail Residence and Business | |
| | • UNE 2w Loop – Design | | Retail Residence and Business | |
| | • UNE Loop Other – Design | | Retail Design | |
| | • UNE Other Design | | Retail Design | |
| | • Local Interconnection Trunks | X | | |
| | <u>Maintenance Average Duration</u> | | | |
| | • Resale Residence | X | | |
| | • Resale Business | X | | |
| | • Resale Design | X | | |
| | • Resale PBX | X | | |
| | • Resale Centrex | X | | |
| | • Resale IDSN | X | | |
| | • UNE Loop and Port Combos | | Retail Residence and Business | |
| | • UNE 2w Loop – Non-Design | | Retail Residence and Business | |
| | • UNE Loop Other - Non-Design | | Retail Residence and Business | |
| | • UNE Other Non Design | | Retail Residence and Business | |
| | • UNE 2w Loop – Design | | Retail Residence and Business | |
| | • UNE Loop Other – Design | | Retail Design | |
| | • UNE Other Design | | Retail Design | |
| | • Local Interconnection Trunks | X | | |
| | <u>Percent Repeat Troubles within 30 Days</u> | | | |
| | • Resale Residence | X | | |

| APPENDIX D Analog and Benchmarks | | | | |
|---|---|---------------------------------------|---------------------------------|-------------------|
| BST SQM Category | MEASURES AND SUB-METRICS | RESALE Retail Analogue | UNES Retail Analogue | Benchmark* |
| | • Resale Business | X | | |
| | • Resale Design | X | | |
| | • Resale PBX | X | | |
| | • Resale Centrex | X | | |
| | • Resale IDSN | X | | |
| | • UNE Loop and Port Combos | | Retail Residence and Business | |
| | • UNE 2w Loop – Non-Design | | Retail Residence and Business | |
| | • UNE Loop Other - Non-Design | | Retail Residence and Business | |
| | • UNE Other Non Design | | Retail Residence and Business | |
| | • UNE 2w Loop – Design | | Retail Residence and Business | |
| | • UNE Loop Other – Design | | Retail Design | |
| | • UNE Other Design | | Retail Design | |
| | • Local Interconnection Trunks | X | | |
| | <u>Out of Service > 24hrs</u> | | | |
| | • Resale Residence | X | | |
| | • Resale Business | X | | |
| | • Resale Design | X | | |
| | • Resale PBX | X | | |
| | • Resale Centrex | X | | |
| | • Resale IDSN | X | | |
| | • UNE Loop and Port Combos | | Retail Residence and Business | |
| | • UNE 2w Loop – Non-Design | | Retail Residence and Business | |
| | • UNE Loop Other - Non-Design | | Retail Residence and Business | |
| | • UNE Other Non Design | | Retail Residence and Business | |
| | • UNE 2w Loop – Design | | Retail Residence and Business | |
| | • UNE Loop Other – Design | | Retail Design | |
| | • UNE Other Design | | Retail Design | |
| | • Local Interconnection Trunks | X | | |
| | <u>OSS Interface Availability</u> | | | |
| | • All systems except ECTA | X | | |
| | • <u>ECTA</u> | | | 99.5% |
| | <u>OSS Response Interval and %</u> | | | |
| | • TAFI (Front End) | X | | |

| APPENDIX D Analog and Benchmarks | | | | |
|---|--|---------------------------------------|---------------------------------|-------------------|
| BST SQM Category | MEASURES AND SUB-METRICS | RESALE Retail Analogue | UNES Retail Analogue | Benchmark* |
| | <ul style="list-style-type: none"> CRIS, DLETH, DLR, OSPCM, LMOS, LMOSUP, MARCH, Predictor, SOCS, LNP (Parity by Design) | PBD | | |
| | <u>Average Answer Time – Repair Center</u> | X | | |
| Billing | <u>Invoice Accuracy</u> | X | | |
| | Mean Time To Deliver Invoices | X | | |
| | Usage Data Delivery Accuracy | X | | |
| | Usage Data Delivery Timeliness | X | | |
| | Usage Data Delivery Completeness | X | | |
| | Mean Time to Deliver Usage | X | | |
| Operator Services (Toll) | Average Speed to Answer | PBD | | |
| | % Answered in “X” Seconds | PBD | | |
| Directory Assistance | Average Speed to Answer | PBD | | |
| | % Answered in “X” Seconds | PBD | | |
| E911 | Timeliness | PBD | | |
| | <u>Accuracy</u> | PBD | | |
| | Mean Interval | PBD | | |
| Trunk Group Performance (Blockage) | Trunk Group Service Report (Percent Trunk Blockage) Any 2 hour period in 24 hours where CLEC blockage exceeds BST blockage by more than 0.5% = a miss using trunk groups 1, 3, 4, 5, 10, 16 for CLECs and 9 for BST. | X | | |
| | Trunk Group Service Report (Percent Trunk Blockage) | X | | |
| LNP | <u>Average Disconnect Timeliness Interval</u> | | | |
| | Percent Missed Installation Appointments | | Retail Residence and Business | |
| | FOC Mechanized | | | 95% ≤4 hours |
| | % Reject Service Request | | Diagnostic | |
| | Average Reject Interval Mechanized | | | 95% ≤1 hour |
| | TSOC | | Diagnostic | |
| | % Flow Through | | | 80% |

| APPENDIX D Analog and Benchmarks | | | | |
|---|---|---------------------------------------|---|-------------------|
| BST SQM Category | MEASURES AND SUB-METRICS | RESALE Retail Analogue | UNES Retail Analogue | Benchmark* |
| | | | | |
| Customer Coordinated Conversions | <u>Coordinated Customer Conversions – UNE Loop</u> | | | 95% ≤ 15min |
| | <u>Coordinated Customer Conversions – LNP</u> | | | 95% ≤ 15 min |
| | | | | |
| Collocation + | % of Due Dates Missed | | | 90% ≤ Commit Date |
| | Average Response Time | | FL PSC is addressing this in generic docket | |
| +A contract with each CLEC required. | <u>Average Arrangement Time</u> | | FL PSC is addressing this in generic docket | |

Note 1: PBD = Parity by Design. UD = Under Development – Benchmarks will be replaced when Analogs are complete.

Note2: The retail analog for UNE Non-Design and UNE 2w Loops – Design is the average of Retail Residence Dispatch and Retail Business Dispatch transactions for the particular month. The retail analog for other UNE Design is Retail Design Dispatch.

Note3: Analog and Benchmarks will be re-evaluated periodically, at least once a year, to validate applicability.

EXHIBIT B

VSEEMIII TIER-1 SUBMETRICS

- ❑ FOC Timeliness (Mechanized only)
- ❑ Reject Interval (Mechanized only)
- ❑ Order Completion Interval (Dispatch only) – Resale POTS
- ❑ Order Completion Interval (Dispatch only) – Resale Design
- ❑ Order Completion Interval (No Dispatch only) – UNE Loop and Port Combos
- ❑ Order Completion Interval ('w' code orders, Dispatch only) – UNE Loops
- ❑ Order Completion Interval (Dispatch only) – IC Trunks
- ❑ Percent Missed Installation Appointments – Resale POTS
- ❑ Percent Missed Installation Appointments – Resale Design
- ❑ Percent Missed Installation Appointments – UNE Loop and Port Combos
- ❑ Percent Missed Installation Appointments – UNE Loops
- ❑ Percent Provisioning Troubles within 4 Days - Resale POTS
- ❑ Percent Provisioning Troubles within 4 Days - Resale Design
- ❑ Percent Provisioning Troubles within 4 Days - UNE Loop and Port Combos
- ❑ Percent Provisioning Troubles within 4 Days - UNE Loops
- ❑ Customer Trouble Report Rate – Resale POTS
- ❑ Customer Trouble Report Rate – Resale Design
- ❑ Customer Trouble Report Rate - UNE Loop and Port Combos
- ❑ Customer Trouble Report Rate - UNE Loops
- ❑ Percent Missed Repair Appointments – Resale POTS
- ❑ Percent Missed Repair Appointments - Resale Design
- ❑ Percent Missed Repair Appointments - UNE Loop and Port Combos
- ❑ Percent Missed Repair Appointments - UNE Loops
- ❑ Maintenance Average Duration – Resale POTS
- ❑ Maintenance Average Duration – Resale Design
- ❑ Maintenance Average Duration - UNE Loop and Port Combos
- ❑ Maintenance Average Duration - UNE Loops
- ❑ Maintenance Average Duration – IC Trunks
- ❑ Percent Repeat Troubles within 30 Days – Resale POTS
- ❑ Percent Repeat Troubles within 30 Days – Resale Design
- ❑ Percent Repeat Troubles within 30 Days - UNE Loop and Port Combos
- ❑ Percent Repeat Troubles within 30 Days - UNE Loops
- ❑ Percent Trunk Blockage
- ❑ LNP Disconnect Timeliness
- ❑ LNP Percent Missed Installation Appointment
- ❑ Coordinated Customer Conversions for UNE Loops
- ❑ Coordinated Customer Conversions for LNP
- ❑ Percent Missed Collocation Due Dates

VSEEMIII TIER-2 SUBMETRICS

- ❑ Percent Response Received within “X” seconds – Pre-Order OSS
- ❑ OSS Interface Availability
- ❑ Order Process Percent Flow-Through (Mechanized only)
- ❑ Order Completion Interval (Dispatch only) – Resale POTS
- ❑ Order Completion Interval (Dispatch only) – Resale Design
- ❑ Order Completion Interval (No Dispatch only) – UNE Loop and Port Combos
- ❑ Order Completion Interval (‘w’ code orders, Dispatch only) – UNE Loops
- ❑ Order Completion Interval (Dispatch only) – IC Trunks
- ❑ Percent Missed Installation Appointments – Resale POTS
- ❑ Percent Missed Installation Appointments – Resale Design
- ❑ Percent Missed Installation Appointments – UNE Loop and Port Combos
- ❑ Percent Missed Installation Appointments – UNE Loops
- ❑ Percent Provisioning Troubles within 4 Days - Resale POTS
- ❑ Percent Provisioning Troubles within 4 Days - Resale Design
- ❑ Percent Provisioning Troubles within 4 Days - UNE Loop and Port Combos
- ❑ Percent Provisioning Troubles within 4 Days - UNE Loops
- ❑ Customer Trouble Report Rate – Resale POTS
- ❑ Customer Trouble Report Rate – Resale Design
- ❑ Customer Trouble Report Rate - UNE Loop and Port Combos
- ❑ Customer Trouble Report Rate - UNE Loops
- ❑ Percent Missed Repair Appointments – Resale POTS
- ❑ Percent Missed Repair Appointments - Resale Design
- ❑ Percent Missed Repair Appointments - UNE Loop and Port Combos
- ❑ Percent Missed Repair Appointments - UNE Loops
- ❑ Maintenance Average Duration – Resale POTS
- ❑ Maintenance Average Duration – Resale Design
- ❑ Maintenance Average Duration - UNE Loop and Port Combos
- ❑ Maintenance Average Duration - UNE Loops
- ❑ Maintenance Average Duration – IC Trunks
- ❑ Percent Repeat Troubles within 30 Days – Resale POTS
- ❑ Percent Repeat Troubles within 30 Days – Resale Design
- ❑ Percent Repeat Troubles within 30 Days - UNE Loop and Port Combos
- ❑ Percent Repeat Troubles within 30 Days - UNE Loops
- ❑ Billing Timeliness
- ❑ Billing Accuracy
- ❑ Usage Data Delivery Timeliness
- ❑ Usage Data Delivery Accuracy
- ❑ Percent Trunk Blockage
- ❑ LNP Disconnect Timeliness
- ❑ LNP Percent Missed Installation Appointment
- ❑ Coordinated Customer Conversions for UNE Loops
- ❑ Coordinated Customer Conversions for LNP
- ❑ Percent Missed Collocation Due Dates

VSEEMIII TIER-3 SUBMETRICS

- ❑ Percent Missed Installation Appointments – Resale POTS
- ❑ Percent Missed Installation Appointments – Resale Design
- ❑ Percent Missed Installation Appointments – UNE Loop and Port Combos
- ❑ Percent Missed Installation Appointments – UNE Loops
- ❑ Percent Missed Repair Appointments – Resale POTS
- ❑ Percent Missed Repair Appointments - Resale Design
- ❑ Percent Missed Repair Appointments - UNE Loop and Port Combos
- ❑ Percent Missed Repair Appointments - UNE Loops
- ❑ Billing Timeliness
- ❑ Billing Accuracy
- ❑ Percent Trunk Blockage
- ❑ Percent Missed Collocation Due Dates

| VSEEM III | MEASURES AND SUB-METRICS | RETAIL ANALOGUE Resale (x) and UNEs | BENCH MARK |
|---------------------|--|--|-------------------|
| Pre-Ordering | Percent Response Received within "X" seconds | Retail Analogue + 4 sec | |
| | OSS Interface Availability | x | |
| Ordering | Percent Flow-Through Service Request (Fully Mechanized only) | | 90% |
| | Firm Order Confirmation Timeliness (Mechanized only) | | 95% ≤ 4 hrs |
| | Reject Interval (Mechanized only) | | 95% ≤ 1 hrs |
| Provisioning | Order Completion Interval (Dispatch only) – Resale POTS | x | |
| | Order Completion Interval (Dispatch only) – Resale Design | x | |
| | Order Completion Interval (No Dispatch only) – UNE Loop & Port Combos | Retail Residence and Business | |
| | Order Completion Interval (Dispatch only) – UNE Loops | Design: Retail Design Dispatch 'w' Orders Non-Design: Retail Res, Bus Dispatch 'w' Orders | |
| | Order Completion Interval (Dispatch only) – IC Trunks | x | |
| | Percent Missed Installation Appointments – Resale POTS | x | |
| | Percent Missed Installation Appointments – Resale Design | x | |
| | Percent Missed Installation Appointments – UNE Loop and Port Combos | Retail Residence and Business | |
| | Percent Missed Installation Appointments – UNE Loops | Design: Retail Design ¹ Non-Design: Retail Res, Bus ¹ | |
| | Percent Provisioning Troubles within 4 Days - Resale POTS | x | |
| | Percent Provisioning Troubles within 4 Days - Resale Design | x | |
| | Percent Provisioning Troubles within 4 Days - UNE Loop and Port Combos | Retail Residence and Business | |
| | Percent Provisioning Troubles within 4 Days - UNE Loops | Design: Retail Design ¹ Non-Design: Retail Res, Bus ¹ | |
| Maintenance | Customer Trouble Report Rate – Resale POTS | x | |
| | Customer Trouble Report Rate – Resale Design | x | |
| | Customer Trouble Report Rate - UNE Loop and Port Combos | Retail Residence and Business | |
| | Customer Trouble Report Rate - UNE Loops | Design: Retail Design ¹ Non-Design: Retail Res, Bus ¹ | |
| | Percent Missed Repair Appointments – Resale POTS | x | |
| | Percent Missed Repair Appointments - Resale Design | x | |
| | Percent Missed Repair Appointments - UNE Loop and Port Combos | Retail Residence and Business | |
| | Percent Missed Repair Appointments - UNE Loops | Design: Retail Design ¹ Non-Design: Retail Res, Bus ¹ | |

NOTES: ¹ The retail analog for UNE Non-Design is the average of all retail residence and retail business transactions for the particular month.
The retail analog for UNE Design is calculated similarly using retail residence, business and design results.
² UD = Under Development

| | | | |
|-----------------------|---|--|-----------------|
| Maintenance Continued | Maintenance Average Duration – Resale POTS | x | |
| | Maintenance Average Duration – Resale Design | x | |
| | Maintenance Average Duration - UNE Loop and Port Combos | Retail Residence and Business | |
| | Maintenance Average Duration - UNE Loops | Design: Retail Design ¹ Non-Design: Retail Res, Bus ¹ | |
| | Maintenance Average Duration – IC Trunks | x | |
| | Percent Repeat Troubles within 30 Days – Resale POTS | x | |
| | Percent Repeat Troubles within 30 Days – Resale Design | x | |
| | Percent Repeat Troubles within 30 Days - UNE Loop and Port Combos | Retail Residence and Business | |
| | Percent Repeat Troubles within 30 Days - UNE Loops | Design: Retail Design ¹ Non-Design: Retail Res, Bus ¹ | |
| Billing | Invoice Accuracy | x | |
| | Mean Time To Deliver Invoices | x | |
| | Usage Data Delivery Accuracy | x | |
| | Usage Data Delivery Timeliness | x | |
| Trunk Blockage | Trunk Group Service Report (Percent Trunk Blockage) | x | |
| LNP | Average Disconnect Timeliness Interval | | UD ² |
| | Percent Missed Installation Appointments | | UD ² |
| CC | Coordinated Customer Conversions – UNE Loop | | 95% ≤ 15min |
| Conversions | Coordinated Customer Conversions – LNP | | 95% ≤ 15 min |
| Collocation | % of Due Dates Missed | | ≤ 10% |

NOTES: ¹ The retail analog for UNE Non-Design is the average of all retail residence and retail business transactions for the particular month.
The retail analog for UNE Design is calculated similarly using retail residence, business and design results.
² UD = Under Development

EXHIBIT C

Statistical Methods for BellSouth Performance Measure Analysis

I. Necessary Properties for a Test Methodology

The statistical process for testing if competing local exchange carriers (CLECs) customers are being treated equally with BellSouth (BST) customers involves more than just a mathematical formula. Three key elements need to be considered before an appropriate decision process can be developed. These are

- the type of data,
- the type of comparison, and
- the type of performance measure.

Once these elements are determined a test methodology should be developed that complies with the following properties.

- Like-to-Like Comparisons. When possible, data should be compared at appropriate levels, e.g. wire center, time of month, dispatched, residential, new orders. The testing process should:
 - Identify variables that may affect the performance measure.
 - Record these important confounding covariates.
 - Adjust for the observed covariates in order to remove potential biases and to make the CLEC and the ILEC units as comparable as possible.
- Aggregate Level Test Statistic. Each performance measure of interest should be summarized by one overall test statistic giving the decision maker a rule that determines whether a statistically significant difference exists. The test statistic should have the following properties.
 - The method should provide a single overall index, on a standard scale.
 - If entries in comparison cells are exactly proportional over a covariate, the aggregated index should be very nearly the same as if comparisons on the covariate had not been done.
 - The contribution of each comparison cell should depend on the number of observations in the cell.
 - Cancellation between comparison cells should be limited.
 - The index should be a continuous function of the observations.
- Production Mode Process. The decision system must be developed so that it does not require intermediate manual intervention, i.e. the process must be a “black box.”
 - Calculations are well defined for possible eventualities.
 - The decision process is an algorithm that needs no manual intervention.
 - Results should be arrived at in a timely manner.
 - The system must recognize that resources are needed for other performance measure-related processes that also must be run in a timely manner.
 - The system should be auditable, and adjustable over time.
- Balancing. The testing methodology should balance Type I and Type II Error probabilities.
 - $P(\text{Type I Error}) = P(\text{Type II Error})$ for well defined null and alternative hypotheses.
 - The formula for a test’s balancing critical value should be simple enough to calculate using standard mathematical functions, i.e. one should avoid methods that require computationally intensive techniques.

- Little to no information beyond the null hypothesis, the alternative hypothesis, and the number of observations should be required for calculating the balancing critical value.

In the following sections we describe appropriate testing processes that adhere as much as possible to the testing principles.

Measurement Types

The performance measures that will undergo testing are of three types:

- 1) means
- 2) proportions, and
- 3) rates

While all three have similar characteristics (a proportion is the average of a measure that takes on only the values of 0 or 1), a proportion or rate is derived from count data while a mean is generally an average of interval measurements.

II. Testing Methodology – The Truncated Z

Many covariates are chosen in order to provide deep comparison levels. In each comparison cell, a Z statistic is calculated. The form of the Z statistic may vary depending on the performance measure, but it should be distributed approximately as a standard normal, with mean zero and variance equal to one. Assuming that the test statistic is derived so that it is negative when the performance for the CLEC is worse than for the ILEC, a positive truncation is done – i.e. if the result is negative it is left alone, if the result is positive it is changed to zero. A weighted average of the truncated statistics is calculated where a cell weight depends on the volume of BST and CLEC orders in the cell. The weighted average is re-centered by the theoretical mean of a truncated distribution, and this is divided by the standard error of the weighted average. The standard error is computed assuming a fixed effects model.

Proportion Measures

For performance measures that are calculated as a proportion, in each adjustment cell, the truncated Z and the moments for the truncated Z can be calculated in a direct manner. In adjustment cells where proportions are not close to zero or one, and where the sample sizes are reasonably large, a normal approximation can be used. In this case, the moments for the truncated Z come directly from properties of the standard normal distribution. If the normal approximation is not appropriate, then the Z statistic is calculated from the hypergeometric distribution. In this case, the moments of the truncated Z are calculated exactly using the hypergeometric probabilities.

Rate Measures

The truncated Z methodology for rate measures has the same general structure for calculating the Z in each cell as proportion measures. For a rate measure, there are a fixed number of circuits or units for the CLEC, n_{2j} and a fixed number of units for BST, n_{1j} . Suppose that the performance measure is a “trouble rate.” The modeling assumption is that the occurrence of a trouble is independent between units and the number of troubles in n circuits follows a Poisson distribution with mean λn where λ is the probability of a trouble in 1 circuit and n is the number of circuits.

In an adjustment cell, if the number of CLEC troubles is greater than 15 and the number of BST troubles is greater than 15, then the Z test is calculated using the normal approximation to the Poisson. In this case, the moments of the truncated Z come directly from properties of the standard normal distribution. Otherwise, if there are very few troubles, the number of CLEC troubles can be modeled using a binomial distribution with n equal to the total number of troubles (CLEC plus BST troubles.) In this case, the moments for the truncated Z are calculated explicitly using the binomial distribution.

Mean Measures

For mean measures, an adjusted t statistic is calculated for each like-to-like cell which has at least 7 BST and 7 CLEC transactions. A permutation test is used when one or both of the BST and CLEC sample sizes is less than 6. Both the adjusted t statistic and the permutation calculation are described in the technical appendix.

APPENDIX TECHNICAL DESCRIPTION

We start by assuming that any necessary trimming of the data is complete, and that the data are disaggregated so that comparisons are made within appropriate classes or adjustment cells that define “like” observations.

NOTATION AND EXACT TESTING DISTRIBUTIONS

Below, we have detailed the basic notation for the construction of the truncated z statistic. In what follows the word “cell” should be taken to mean a like-to-like comparison cell that has both one (or more) ILEC observation and one (or more) CLEC observation.

- L = the total number of occupied cells
- j = 1, ..., L; an index for the cells
- n_{1j} = the number of ILEC transactions in cell j
- n_{2j} = the number of CLEC transactions in cell j
- n_j = the total number transactions in cell j; $n_{1j} + n_{2j}$
- X_{1jk} = individual ILEC transactions in cell j; $k = 1, \dots, n_{1j}$
- X_{2jk} = individual CLEC transactions in cell j; $k = 1, \dots, n_{2j}$
- Y_{jk} = individual transaction (both ILEC and CLEC) in cell j

$$= \begin{cases} X_{1jk} & k = 1, \dots, n_{1j} \\ X_{2jk} & k = n_{1j} + 1, \dots, n_j \end{cases}$$
- $\Phi^{-1}(\cdot)$ = the inverse of the cumulative standard normal distribution function

For Mean Performance Measures the following additional notation is needed.

- \bar{X}_{1j} = the ILEC sample mean of cell j
- \bar{X}_{2j} = the CLEC sample mean of cell j
- S_{1j}^2 = the ILEC sample variance in cell j
- S_{2j}^2 = the CLEC sample variance in cell j
- y_{jk} = a random sample of size n_{2j} from the set of Y_{j1}, \dots, Y_{jn_j} ; $k = 1, \dots, n_{2j}$
- M_j = the total number of distinct pairs of samples of size n_{1j} and n_{2j} ;

$$= \binom{n_j}{n_{1j}}$$

The exact parity test is the permutation test based on the "modified Z" statistic. For large samples, we can avoid permutation calculations since this statistic will be normal (or Student's t) to a good approximation. For small samples, where we cannot avoid permutation calculations, we have found that the difference between "modified Z" and the textbook "pooled Z" is negligible. We therefore propose to use the permutation test based on pooled Z for small samples. This decision speeds up the permutation computations considerably, because for each permutation we need only compute the sum of the CLEC sample values, and not the pooled statistic itself.

A permutation probability mass function distribution for cell j, based on the “pooled Z” can be written as

$$PM(t) = P\left(\sum_k y_{jk} = t\right) = \frac{\text{the number of samples that sum to } t}{M_j},$$

and the corresponding cumulative permutation distribution is

$$CPM(t) = P\left(\sum_k y_{jk} \leq t\right) = \frac{\text{the number of samples with sum } \leq t}{M_j}.$$

For Proportion Performance Measures the following notation is defined

- a_{1j} = the number of ILEC cases possessing an attribute of interest in cell j
- a_{2j} = the number of CLEC cases possessing an attribute of interest in cell j
- a_j = the number of cases possessing an attribute of interest in cell j ; $a_{1j} + a_{2j}$

The exact distribution for a parity test is the hypergeometric distribution. The hypergeometric probability mass function distribution for cell j is

$$HG(h) = P(H = h) = \begin{cases} \frac{\binom{n_{1j}}{h} \binom{n_{2j}}{a_j - h}}{\binom{n_j}{a_j}}, & \max(0, a_j - n_{2j}) \leq h \leq \min(a_j, n_{1j}) \\ 0 & \text{otherwise} \end{cases},$$

and the cumulative hypergeometric distribution is

$$CHG(x) = P(H \leq x) = \begin{cases} 0 & x < \max(0, a_j - n_{1j}) \\ \sum_{h=\max(0, a_j - n_{1j})}^x HG(h), & \max(0, a_j - n_{1j}) \leq x \leq \min(a_j, n_{2j}) \\ 1 & x > \min(a_j, n_{2j}) \end{cases}.$$

For Rate Measures, the notation needed is defined as

- b_{1j} = the number of ILEC base elements in cell j
- b_{2j} = the number of CLEC base elements in cell j
- b_j = the total number of base elements in cell j ; $b_{1j} + b_{2j}$
- \hat{r}_{1j} = the ILEC sample rate of cell j ; n_{1j}/b_{1j}
- \hat{r}_{2j} = the CLEC sample rate of cell j ; n_{2j}/b_{2j}
- q_j = the relative proportion of CLEC elements for cell j ; b_{2j}/b_j

The exact distribution for a parity test is the binomial distribution. The binomial probability mass function distribution for cell j is

$$BN(k) = P(B = k) = \begin{cases} \binom{n_j}{k} q_j^k (1-q_j)^{n_j-k}, & 0 \leq k \leq n_j \\ 0 & \text{otherwise} \end{cases}$$

and the cumulative binomial distribution is

$$CBN(x) = P(B \leq x) = \begin{cases} 0 & x < 0 \\ \sum_{k=0}^x BN(k), & 0 \leq x \leq n_j \\ 1 & x > n_j \end{cases}$$

CALCULATING THE TRUNCATED Z

The general methodology for calculating an aggregate level test statistic is outlined below.

1. **Calculate cell weights, W_j .** A weight based on the number of transactions is used so that a cell which has a larger number of transactions has a larger weight. The actual weight formulae will depend on the type of measure.

Mean Measure

$$W_j = \sqrt{\frac{n_{1j}n_{2j}}{n_j}}$$

Proportion Measure

$$W_j = \sqrt{\frac{n_{2j}n_{1j}}{n_j} \cdot \frac{a_j}{n_j} \cdot \left(1 - \frac{a_j}{n_j}\right)}$$

Rate Measure

$$W_j = \sqrt{\frac{b_{1j}b_{2j}}{b_j} \cdot \frac{n_j}{b_j}}$$

2. **In each cell, calculate a Z value, Z_j .** A Z statistic with mean 0 and variance 1 is needed for each cell.

- If $W_j = 0$, set $Z_j = 0$.
- Otherwise, the actual Z statistic calculation depends on the type of performance measure.

Mean Measure

$$Z_j = \Phi^{-1}(\alpha)$$

where α is determine by the following algorithm.

If $\min(n_{1j}, n_{2j}) > 6$, then determine α as

$$\alpha = P(t_{n_j-1} \leq T_j),$$

that is, α is the probability that a t random variable with $n_{1j} - 1$ degrees of freedom, is less than

$$T_j = t_j + \frac{g}{6} \left(\frac{n_{1j} + 2n_{2j}}{\sqrt{n_{1j} n_{2j} (n_{1j} + n_{2j})}} \right) \left(t^2 + \frac{n_{2j} - n_{1j}}{2n_{1j} + n_{2j}} \right),$$

where

$$t_j = \frac{\bar{X}_{1j} - \bar{X}_{2j}}{s_{1j} \sqrt{\frac{1}{n_{1j}} + \frac{1}{n_{2j}}}}$$

and the coefficient g is an estimate of the skewness of the parent population, which we assume is the same in all cells. It can be estimated from the ILEC values in the largest cells. This needs to be done only once for each measure. We have found that attempting to estimate this skewness parameter for each cell separately leads to excessive variability in the "adjusted" t . We therefore use a single compromise value in all cells.

Note, that t_j is the "modified Z" statistic. The statistic T_j is a "modified Z" corrected for the skewness of the ILEC data.

If $\min(n_{1j}, n_{2j}) \leq 6$, and

a) $M_j \leq 1,000$ (the total number of distinct pairs of samples of size n_{1j} and n_{2j} is 1,000 or less).

- Calculate the sample sum for all possible samples of size n_{2j} .
- Rank the sample sums from smallest to largest. Ties are dealt by using average ranks.
- Let R_0 be the rank of the observed sample sum with respect all the sample sums.

$$\alpha = 1 - \frac{R_0 - 0.5}{M_j}$$

b) $M_j > 1,000$

- Draw a random sample of 1,000 sample sums from the permutation distribution.
- Add the observed sample sum to the list. There is a total of 1001 sample sums. Rank the sample sums from smallest to largest. Ties are dealt by using average ranks.
- Let R_0 be the rank of the observed sample sum with respect all the sample sums.

$$\alpha = 1 - \frac{R_0 - 0.5}{1001}.$$

Proportion Measure

$$Z_j = \frac{n_j a_{1j} - n_{1j} a_j}{\sqrt{\frac{n_{1j} n_{2j} a_j (n_j - a_j)}{n_j - 1}}}.$$

Rate Measure

$$Z_j = \frac{n_{1j} - n_j q_j}{\sqrt{n_j q_j (1 - q_j)}}.$$

3. **Obtain a truncated Z value for each cell, Z_j^* .** To limit the amount of cancellation that takes place between cell results during aggregation, cells whose results suggest possible favoritism are left alone. Otherwise the cell statistic is set to zero. This means that positive equivalent Z values are set to 0, and negative values are left alone. Mathematically, this is written as

$$Z_j^* = \min(0, Z_j).$$

4. **Calculate the theoretical mean and variance of the truncated statistic under the null hypothesis of parity, $E(Z_j^* | H_0)$ and $\text{Var}(Z_j^* | H_0)$.** In order to compensate for the truncation in step 3, an aggregated, weighted sum of the Z_j^* will need to be centered and scaled properly so that the final aggregate statistic follows a standard normal distribution.

- If $W_j = 0$, then no evidence of favoritism is contained in the cell. The formulae for calculating $E(Z_j^* | H_0)$ and $\text{Var}(Z_j^* | H_0)$ cannot be used. Set both equal to 0.
- If $\min(n_{1j}, n_{2j}) > 6$ for a mean measure, $\min\left\{a_{1j}\left(1 - \frac{a_{1j}}{n_{1j}}\right), a_{2j}\left(1 - \frac{a_{2j}}{n_{2j}}\right)\right\} > 9$ for a proportion measure, or $\min(n_{1j}, n_{2j}) > 15$ and $n_j q_j (1 - q_j) > 9$ for a rate measure then

$$E(Z_j^* | H_0) = -\frac{1}{\sqrt{2\pi}}, \text{ and}$$

$$\text{Var}(Z_j^* | H_0) = \frac{1}{2} - \frac{1}{2\pi}.$$

- Otherwise, determine the total number of values for Z_j^* . Let z_{ji} and θ_{ji} , denote the values of Z_j^* and the probabilities of observing each value, respectively.

$$E(Z_j^* | H_0) = \sum_i \theta_{ji} z_{ji}, \text{ and}$$

$$\text{Var}(Z_j^* | H_0) = \sum_i \theta_{ji} z_{ji}^2 - [E(Z_j^* | H_0)]^2.$$

The actual values of the z's and θ 's depends on the type of measure, and the sums in the equations are over all possible values of the index i.

Mean Measure

$$N_j = \min(M_j, 1,000), \quad i = 1, \dots, N_j$$

$$z_{ji} = \min \left\{ 0, 1 - \Phi^{-1} \left(\frac{R_i - 0.5}{N_j} \right) \right\} \quad \text{where } R_i \text{ is the rank of sample sum } i$$

$$\theta_j = \frac{1}{N_j}$$

Proportion Measure

$$z_{ji} = \min \left\{ 0, \frac{n_j i - n_{1j} a_j}{\sqrt{\frac{n_{1j} n_{2j} a_j (n_j - a_j)}{n_j - 1}}} \right\}, \quad i = \min(a_j, n_{2j}), \dots, \max(0, a_j - n_{1j})$$

$$\theta_{ji} = \text{HG}(i)$$

Rate Measure

$$z_{ji} = \min \left\{ 0, \frac{i - n_j q_j}{\sqrt{n_j q_j (1 - q_j)}} \right\}, \quad i = 0, \dots, n_j$$

$$\theta_{ji} = \text{BN}(i)$$

5. Calculate the aggregate test statistic, Z^T .

$$Z^T = \frac{\sum_j W_j Z_j^* - \sum_j W_j E(Z_j^* | H_0)}{\sqrt{\sum_j W_j^2 \text{Var}(Z_j^* | H_0)}}$$

The Balancing Critical Value

There are four key elements of the statistical testing process:

1. the null hypothesis, H_0 , that parity exists between ILEC and CLEC services
2. the alternative hypothesis, H_a , that the ILEC is giving better service to its own customers
3. the Truncated Z test statistic, Z^T , and
4. a critical value, c

The decision rule¹ is

- If $Z^T < c$ then accept H_a .
- If $Z^T \geq c$ then accept H_0 .

There are two types of error possible when using such a decision rule:

¹ This decision rule assumes that a negative test statistic indicates poor service for the CLEC customer. If the opposite is true, then reverse the decision rule.

Type I Error: Deciding favoritism exists when there is, in fact, no favoritism.
Type II Error: Deciding parity exists when there is, in fact, favoritism.

The probabilities of each type of each are:

Type I Error: $\alpha = P(Z^T < c | H_0)$.
Type II Error: $\beta = P(Z^T \geq c | H_a)$.

We want a balancing critical value, c_B , so that $\alpha = \beta$.

It can be shown that.

$$c_B = \frac{\sum_j W_j M(m_j, se_j) - \sum_j W_j \frac{-1}{\sqrt{2\pi}}}{\sqrt{\sum_j W_j^2 V(m_j, se_j) + \sum_j W_j^2 \left(\frac{1}{2} - \frac{1}{2\pi}\right)}}$$

where

$$M(\mu, \sigma) = \mu \Phi\left(\frac{-\mu}{\sigma}\right) - \sigma \phi\left(\frac{-\mu}{\sigma}\right)$$

$$V(\mu, \sigma) = (\mu^2 + \sigma^2) \Phi\left(\frac{-\mu}{\sigma}\right) - \mu \sigma \phi\left(\frac{-\mu}{\sigma}\right) - M(\mu, \sigma)^2$$

$\Phi(\cdot)$ is the cumulative standard normal distribution function, and $\phi(\cdot)$ is the standard normal density function.

This formula assumes that Z_j is approximately normally distributed within cell j . When the cell sample sizes, n_{1j} and n_{2j} , are small this may not be true. It is possible to determine the cell mean and variance under the null hypothesis when the cell sample sizes are small. It is much more difficult to determine these values under the alternative hypothesis. Since the cell weight, W_j will also be small (see calculate weights section above) for a cell with small volume, the cell mean and variance will not contribute much to the weighted sum. Therefore, the above formula provides a reasonable approximation to the balancing critical value.

The values of m_j and se_j will depend on the type of performance measure.

Mean Measure

For mean measures, one is concerned with two parameters in each cell, namely, the mean and variance. A possible lack of parity may be due to a difference in cell means, and/or a difference in cell variances. One possible set of hypotheses that capture this notion, and take into account the assumption that transaction are identically distributed within cells is:

$$H_0: \mu_{1j} = \mu_{2j}, \sigma_{1j}^2 = \sigma_{2j}^2$$

$$H_a: \mu_{2j} = \mu_{1j} + \delta_j \cdot \sigma_{1j}, \sigma_{2j}^2 = \lambda_j \cdot \sigma_{1j}^2 \quad \delta_j > 0, \lambda_j \geq 1 \text{ and } j = 1, \dots, L.$$

Under this form of alternative hypothesis, the cell test statistic Z_j has mean and standard error given by

$$m_j = \frac{-\delta_j}{\sqrt{\frac{1}{n_{1j}} + \frac{1}{n_{2j}}}}, \text{ and}$$

$$se_j = \sqrt{\frac{\lambda_j n_{1j} + n_{2j}}{n_{1j} + n_{2j}}}$$

Proportion Measure

For a proportion measure there is only one parameter of interest in each cell, the proportion of transaction possessing an attribute of interest. A possible lack of parity may be due to a difference in cell proportions. A set of hypotheses that take into account the assumption that transaction are identically distributed within cells while allowing for an analytically tractable solution is:

$$H_0: \frac{p_{2j}(1-p_{1j})}{(1-p_{2j})p_{1j}} = 1$$

$$H_a: \frac{p_{2j}(1-p_{1j})}{(1-p_{2j})p_{1j}} = \psi_j \quad \psi_j > 1 \text{ and } j = 1, \dots, L.$$

These hypotheses are based on the “odds ratio.” If the transaction attribute of interest is a missed trouble repair, then an interpretation of the alternative hypothesis is that a CLEC trouble repair appointment is ψ_j times more likely to be missed than an ILEC trouble.

Under this form of alternative hypothesis, the within cell asymptotic mean and variance of a_{1j} are given by²

$$E(a_{1j}) = n_j \pi_j^{(1)}$$

$$\text{var}(a_{1j}) = \frac{n_j}{\frac{1}{\pi_j^{(1)}} + \frac{1}{\pi_j^{(2)}} + \frac{1}{\pi_j^{(3)}} + \frac{1}{\pi_j^{(4)}}}$$

where

² Stevens, W. L. (1951) Mean and Variance of an entry in a Contingency Table. *Biometrika*, **38**, 468-470.

$$\begin{aligned}\pi_j^{(1)} &= f_j^{(1)} \left(n_j^2 + f_j^{(2)} + f_j^{(3)} - f_j^{(4)} \right) \\ \pi_j^{(2)} &= f_j^{(1)} \left(-n_j^2 - f_j^{(2)} + f_j^{(3)} + f_j^{(4)} \right) \\ \pi_j^{(3)} &= f_j^{(1)} \left(-n_j^2 + f_j^{(2)} - f_j^{(3)} + f_j^{(4)} \right) \\ \pi_j^{(4)} &= f_j^{(1)} \left(n_j^2 \left(\frac{2}{\psi_j} - 1 \right) - f_j^{(2)} - f_j^{(3)} - f_j^{(4)} \right) \\ f_j^{(1)} &= \frac{1}{2n_j^2 \left(\frac{1}{\psi_j} - 1 \right)} \\ f_j^{(2)} &= n_j n_{1j} \left(\frac{1}{\psi_j} - 1 \right) \\ f_j^{(3)} &= n_j a_j \left(\frac{1}{\psi_j} - 1 \right) \\ f_j^{(4)} &= \sqrt{n_j^2 \left[4n_{1j} (n_j - a_j) \left(\frac{1}{\psi_j} - 1 \right) + \left(n_j + (a_j - n_{1j}) \left(\frac{1}{\psi_j} - 1 \right) \right)^2 \right]}\end{aligned}$$

Recall that the cell test statistic is given by

$$Z_j = \frac{n_j a_{1j} - n_{1j} a_j}{\sqrt{\frac{n_{1j} n_{2j} a_j (n_j - a_j)}{n_j - 1}}}$$

Using the equations above, we see that Z_j has mean and standard error given by

$$\begin{aligned}m_j &= \frac{n_j^2 \pi_j^{(1)} - n_{1j} a_j}{\sqrt{\frac{n_{1j} n_{2j} a_j (n_j - a_j)}{n_j - 1}}}, \text{ and} \\ se_j &= \sqrt{\frac{n_j^3 (n_j - 1)}{n_{1j} n_{2j} a_j (n_j - a_j) \left(\frac{1}{\pi_j^{(1)}} + \frac{1}{\pi_j^{(2)}} + \frac{1}{\pi_j^{(3)}} + \frac{1}{\pi_j^{(4)}} \right)}}.\end{aligned}$$

Rate Measure

A rate measure also has only one parameter of interest in each cell, the rate at which a phenomenon is observed relative to a base unit, e.g. the number of troubles per available line. A possible lack of parity may be due to a difference in cell rates. A set of hypotheses that take into account the assumption that transaction are identically distributed within cells is:

$$H_0: r_{1j} = r_{2j}$$

$$H_a: r_{2j} = \epsilon_j r_{1j} \quad \epsilon_j > 1 \text{ and } j = 1, \dots, L.$$

Given the total number of ILEC and CLEC transactions in a cell, n_j , and the number of base elements, b_{1j} and b_{2j} , the number of ILEC transaction, n_{1j} , has a binomial distribution from n_j trials and a probability of

$$q_j^* = \frac{r_{1j} b_{1j}}{r_{1j} b_{1j} + r_{2j} b_{2j}}.$$

Therefore, the mean and variance of n_{1j} , are given by

$$\begin{aligned} E(n_{1j}) &= n_j q_j^* \\ \text{var}(n_{1j}) &= n_j q_j^* (1 - q_j^*) \end{aligned}$$

Under the null hypothesis

$$q_j^* = q_j = \frac{b_{1j}}{b_j},$$

but under the alternative hypothesis

$$q_j^* = q_j^a = \frac{b_{1j}}{b_{1j} + \varepsilon_j b_{2j}}.$$

Recall that the cell test statistic is given by

$$Z_j = \frac{n_{1j} - n_j q_j}{\sqrt{n_j q_j (1 - q_j)}}.$$

Using the relationships above, we see that Z_j has mean and standard error given by

$$m_j = \frac{n_j (q_j^a - q_j)}{\sqrt{n_j q_j (1 - q_j)}} = (1 - \varepsilon_j) \sqrt{\frac{n_j b_{1j} b_{2j}}{b_{1j} + \varepsilon_j b_{2j}}}, \text{ and}$$

$$se_j = \sqrt{\frac{q_j^a (1 - q_j^a)}{q_j (1 - q_j)}} = \sqrt{\varepsilon_j} \frac{b_j}{b_{1j} + \varepsilon_j b_{2j}}.$$

Determining the Parameters of the Alternative Hypothesis

In this appendix we have indexed the alternative hypothesis of mean measures by two sets of parameters, λ_j and δ_j . Proportion and rate measures have been indexed by one set of parameters each, ψ_j and ε_j respectively. While statistical science can be used to evaluate the impact of different choices of these parameters, there is not much that an appeal to statistical principles can offer in directing specific choices. Specific choices are best left to telephony experts. Still, it is possible to comment on some aspects of these choices:

- Parameter Choices for λ_j . The set of parameters λ_j index alternatives to the null hypothesis that arise because there might be greater unpredictability or variability in the delivery of service to a CLEC customer over that which would be achieved for an otherwise comparable ILEC customer. While concerns about differences in the variability of service are important, it turns out that the truncated Z testing which is being recommended here is relatively insensitive to all but very large values of the λ_j . Put another way, reasonable differences in the values chosen here could make very little difference in the balancing points chosen.

- Parameter Choices for δ_j . The set of parameters δ_j are much more important in the choice of the balancing point than was true for the λ_j . The reason for this is that they directly index differences in average service. The truncated Z test is very sensitive to any such differences; hence, even small disagreements among experts in the choice of the δ_j could be very important. Sample size matters here too. For example, setting all the δ_j to a single value – $\delta_j = \delta$ – might be fine for tests across individual CLECs where currently in Louisiana the CLEC customer bases are not too different. Using the same value of δ for the overall state testing does not seem sensible, however, since the state sample would be so much larger.
- Parameter Choices for ψ_j or ϵ_j . The set of parameters ψ_j or ϵ_j are also important in the choice of the balancing point for tests of their respective measures. The reason for this is that they directly index increases in the proportion or rate of service performance. The truncated Z test is sensitive to such increases; but not as sensitive as the case of δ_j for mean measures. Sample size matters here as well. As with mean measures, using the same value of ψ or ϵ for the overall state testing does not seem sensible since the state sample would be so much larger.

The bottom line here is that beyond a few general considerations, like those given above, a principled approach to the choice of the alternative hypotheses to guard against, must come from elsewhere.

DECISION PROCESS

Once Z^T has been calculated, it is compared to the balancing critical value to determine if the ILEC is favoring its own customers over a CLEC's customers.

This critical value changes as the ILEC and CLEC transaction volume change. One way to make this transparent to the decision maker, is to report the difference between the test statistic and the critical value, $diff = Z^T - c_B$. If favoritism is concluded when $Z^T < c_B$, then the $diff < 0$ indicates favoritism.

This make it very easy to determine favoritism: a positive $diff$ suggests no favoritism, and a negative $diff$ suggests favoritism.

EXHIBIT D

BST VSEEM REMEDY PROCEDURE

TIER-1 CALCULATION FOR RETAIL ANALOGUES:

1. Calculate the overall test statistic for each CLEC; z^T_{CLEC1} (See Exhibit C)
2. Calculate the balancing critical value ($C_{B_{CLEC1}}$) that is associated with the alternative hypothesis (for fixed parameters δ , ψ or ϵ). (See Exhibit C)
3. If the overall test statistic is equal to or above the balancing critical value, stop here. Otherwise, go to step 4.
4. Calculate the Parity Gap by subtracting the value of step 2. from that of step 1.;
 $z^T_{CLEC1} - C_{B_{CLEC1}}$
5. Calculate the Volume Proportion using a linear distribution with slope of $\frac{1}{4}$. This can be accomplished by taking the absolute value of the Parity Gap from step 4. divided by 4;
 $ABS((z^T_{CLEC1} - C_{B_{CLEC1}}) / 4)$. All parity gaps equal or greater to 4 will result in a volume proportion of 100%.
6. Calculate the Affected Volume by multiplying the Volume Proportion from step 5. by the Total CLEC₁ Volume in the negatively affected cell; where the cell value is negative. (See Exhibit C)
7. Calculate the payment to Adelphia by multiplying the result of step 6. by the appropriate dollar amount from the fee schedule.

So, Adelphia payment = Affected Volume_{CLEC1} * \$\$ from Fee Schedule

Example: Adelphia Missed Installation Appointments (MIA) for Resale POTS

| | n_I | n_C | MIA_I | MIA_C | z^T_{CLEC1} | C_B | Parity Gap | Volume Proportion | Affected Volume |
|-------|-------|-------|---------|---------|-------------------------------|-------|-------------------|-------------------|-----------------|
| State | 50000 | 600 | 9% | 16% | -1.92 | -0.21 | 1.71 | 0.4275 | |
| Cell | | | | | <u>z_{CLEC1}</u> | | | | |
| 1 | | 150 | 0.091 | 0.112 | -1.994 | | | | 64 |
| 2 | | 75 | 0.176 | 0.098 | 0.734 | | | | |
| 3 | | 10 | 0.128 | 0.333 | -2.619 | | | | 4 |
| 4 | | 50 | 0.158 | 0.242 | -2.878 | | | | 21 |
| 5 | | 15 | 0.245 | 0.075 | 1.345 | | | | |
| 6 | | 200 | 0.156 | 0.130 | 0.021 | | | | |
| 7 | | 30 | 0.166 | 0.233 | -0.600 | | | | 13 |
| 8 | | 20 | 0.106 | 0.127 | -0.065 | | | | 9 |
| 9 | | 40 | 0.193 | 0.218 | -0.918 | | | | 17 |
| 10 | | 10 | 0.160 | 0.235 | -0.660 | | | | 4 |
| | | | | | | | | | 133 |

where n_I = ILEC observations and n_C = Adelphia observations

Payout for Adelphia is (133 units) * (\$100/unit) = \$13,300

TIER-2 CALCULATION for RETAIL ANALOGUES:

1. Tier-2 is triggered by three monthly failures of any VSEEM submetric in the same quarter.
2. Calculate the overall test statistic for the CLEC Aggregate using all transactions from the calendar quarter; Z_{CLECA}^T
3. Calculate the balancing critical value ($C_{B_{CLECA}}$) that is associated with the alternative hypothesis (for fixed parameters δ, ψ or ϵ). (See Exhibit C)
4. If the overall test statistic is equal to or above the balancing critical value for the calendar quarter, stop here. Otherwise, go to step 5.
5. Calculate the Parity Gap by subtracting the value of step 3. from that of step 2.;
 $Z_{CLECA}^T - C_{B_{CLECA}}$
6. Calculate the Volume Proportion using a linear distribution with slope of $\frac{1}{4}$. This can be accomplished by dividing the Parity Gap from step 5. by 4; $ABS((Z_{CLECA}^T - C_{B_{CLECA}}) / 4)$. All parity gaps equal or greater to 4 will result in a volume proportion of 100%.
7. Calculate the Affected Volume by multiplying the Volume Proportion from step 6. by the Total $CLECA_A$ Volume (CLEC Aggregate) in the negatively affected cell; where the cell value is negative (See Exhibit C).
8. Calculate the payment to State Designated Agency by multiplying the result of step 7. by the appropriate dollar amount from the fee schedule.

So, State Designated Agency payment = Affected Volume_{CLECA} * \$\$ from Fee Schedule

Example: CLEC-A Missed Installation Appointments (MIA) for Resale POTS

| State Quarter | n_I | n_C | MIA_I | MIA_C | Z_{CLECA}^T | C_B | Parity Gap | Volume Proportion | Affected Volume |
|---------------|--------|-------|---------|---------|-------------------------------|-------|-------------------|-------------------|-----------------|
| 1 | 180000 | 2100 | 9% | 16% | -1.92 | -0.21 | 1.71 | 0.4275 | |
| Cell | | | | | <u>Z_{CLECA}</u> | | | | |
| 1 | | 500 | 0.091 | 0.112 | -1.994 | | | | 214 |
| 2 | | 300 | 0.176 | 0.098 | 0.734 | | | | |
| 3 | | 80 | 0.128 | 0.333 | -2.619 | | | | 34 |
| 4 | | 205 | 0.158 | 0.242 | -2.878 | | | | 88 |
| 5 | | 45 | 0.245 | 0.075 | 1.345 | | | | |
| 6 | | 605 | 0.156 | 0.130 | 0.021 | | | | |
| 7 | | 80 | 0.166 | 0.233 | -0.600 | | | | 34 |
| 8 | | 40 | 0.106 | 0.127 | -0.065 | | | | 17 |

| | | | | |
|----|-----|-------|-------|--------|
| 9 | 165 | 0.193 | 0.218 | -0.918 |
| 10 | 80 | 0.160 | 0.235 | -0.660 |

| |
|-----------|
| 71 |
| 34 |
| <hr/> 492 |

where n_i = ILEC observations and n_c = CLEC-A observations

Payout for CLEC-A is (492 units) * (\$300/unit) = \$147,600

Tier-3

Tier-3 uses the monthly CLEC Aggregate results in a given State. Tier-3 is triggered when five of the twelve Tier-3 sub-metrics experience consecutive failures in a given calendar quarter. The table below displays a situation that would trigger a Tier-3 failure, and one that would not.

| Process | Measures | TIER-3 FAILURE X = Miss | | | NOT A TIER-3 FAILURE X = Miss | | |
|--|--------------------------------------|----------------------------|-----|-----|----------------------------------|-----|-----|
| | | Jan | Feb | Mar | Jan | Feb | Mar |
| Percent Missed Installation Appointments | Resale POTS | X | X | X | X | | |
| | Resale Design | X | | | X | X | X |
| | UNE Loop & Port Combo | | X | | | | |
| | UNE Loops | X | X | X | | | |
| Percent Missed Repair Appointments | Resale POTS | X | X | X | X | | X |
| | Resale Design | | X | X | | X | |
| | UNE Loop & Port Combo | | | | | X | X |
| | UNE Loops | | | | X | | |
| Billing | Billing Accuracy | X | X | X | | | |
| | Billing Timeliness | | | | X | X | X |
| Trunk Blockage | Percent Trunk Blockage | X | X | X | | | |
| Collocation | Percent Missed Collocation Due Dates | | | | | | |

Tier-3 is effective immediately after quarter results, and can only be lifted when two of the five failed sub-metrics show compliance for two consecutive months in the following quarter.

All tiers standalone, such that triggering Tier-3 will not cease payout of any Tier-1 or Tier-2 failures.

TIER-1 CALCULATION FOR BENCHMARKS:

1. For each CLEC, with five or more observations, calculate monthly performance results for the State.
2. CLECs having observations (sample sizes) between 5 and 30 will use Table I below:

TABLE I SMALL SAMPLE SIZE TABLE
(95% Confidence)

| Sample Size | Equivalent 90% Benchmark | Equivalent 95% Benchmark | Sample Size | Equivalent 90% Benchmark | Equivalent 95% Benchmark |
|-------------|--------------------------|--------------------------|-------------|--------------------------|--------------------------|
| 5 | 60.00% | 80.00% | 16 | 75.00% | 87.50% |
| 6 | 66.67% | 83.33% | 17 | 76.47% | 82.35% |
| 7 | 71.43% | 85.71% | 18 | 77.78% | 83.33% |
| 8 | 75.00% | 75.00% | 19 | 78.95% | 84.21% |
| 9 | 66.67% | 77.78% | 20 | 80.00% | 85.00% |
| 10 | 70.00% | 80.00% | 21 | 76.19% | 85.71% |
| 11 | 72.73% | 81.82% | 22 | 77.27% | 86.36% |
| 12 | 75.00% | 83.33% | 23 | 78.26% | 86.96% |
| 13 | 76.92% | 84.62% | 24 | 79.17% | 87.50% |
| 14 | 78.57% | 85.71% | 25 | 80.00% | 88.00% |
| 15 | 73.33% | 86.67% | 26 | 80.77% | 88.46% |
| | | | 27 | 81.48% | 88.89% |
| | | | 28 | 78.57% | 89.29% |
| | | | 29 | 79.31% | 86.21% |
| | | | 30 | 80.00% | 86.67% |

3. If the percentage (or equivalent percentage for small samples) is equal to or below the benchmark standard, stop here. Otherwise, go to step 4.
4. Determine the Volume Proportion by taking the difference between the benchmark and the actual performance result.
5. Calculate the Affected Volume by multiplying the Volume Proportion from step 4. by the Total CLEC₁ Volume.
6. Calculate the payment to Adelphia by multiplying the result of step 5. by the appropriate dollar amount from the fee schedule.

So, Adelphia payment = Affected Volume_{CLEC1} * \$\$ from Fee Schedule

Example: Adelphia Missed Installation Appointments (MIA) for UNE Loops

| | n_c | Benchmark | MIA_c | Volume Proportion | Affected Volume |
|-------|-------|-----------|---------|-------------------|-----------------|
| State | 600 | 9% | 12% | .03 | 18 |

Payout for Adelphia is (18 units) * (\$400/unit) = \$7,200

TIER-1 CALCULATION FOR BENCHMARKS (IN THE FORM OF A TARGET):

1. For each, with five or more observations, CLEC calculate monthly performance results for the State.
2. CLECs having observations (sample sizes) between 5 and 30 will use Table I above.
3. Calculate the interval distribution based on the same data set used in step 1.
4. If the 'percent within' is equal to or exceeds the benchmark standard, stop here. Otherwise, go to step 5.
5. Determine the Volume Proportion by taking the difference between 100% and the actual performance result.
6. Calculate the Affected Volume by multiplying the Volume Proportion from step 5. by the Total CLEC₁ Volume.
7. Calculate the payment to Adelphia by multiplying the result of step 6. by the appropriate dollar amount from the fee schedule.

So, Adelphia payment = Affected Volume_{CLEC1} * \$\$ from Fee Schedule

Example: Adelphia Reject Timeliness

| | n_c | Benchmark | Reject Timeliness _c | Volume Proportion | Affected Volume |
|-------|-------|-------------------|--------------------------------|-------------------|-----------------|
| State | 600 | 95% within 1 hour | 93% within 1 hour | .07 | 42 |

Payout for Adelphia is (42 units) * (\$100/unit) = \$4,200

TIER-2 CALCULATIONS for BENCHMARKS:

Tier-2 calculations for benchmark measures are the same as the Tier-1 benchmark calculations except the CLEC Aggregate data having failed for three months in a given calendar quarter is being assessed.

EXHIBIT E

Table-1

LIQUIDATED DAMAGES TABLE FOR TIER-1 MEASURES

| PER AFFECTED ITEM | | | | | | |
|--|---------|---------|---------|---------|---------|---------|
| | Month 1 | Month 2 | Month3 | Month4 | Month 5 | Month 6 |
| Ordering | \$40 | \$50 | \$60 | \$70 | \$80 | \$90 |
| Provisioning | \$100 | \$125 | \$175 | \$250 | \$325 | \$500 |
| Provisioning UNE (Coordinated Customer Conversions) | \$400 | \$450 | \$500 | \$550 | \$650 | \$800 |
| Maintenance and Repair | \$100 | \$125 | \$175 | \$250 | \$325 | \$500 |
| Maintenance and Repair UNE | \$400 | \$450 | \$500 | \$550 | \$650 | \$800 |
| LNP | \$150 | \$250 | \$500 | \$600 | \$700 | \$800 |
| IC Trunks | \$100 | \$125 | \$175 | \$250 | \$325 | \$500 |
| Collocation | \$5,000 | \$5,000 | \$5,000 | \$5,000 | \$5,000 | \$5,000 |

Table-2

VOLUNTARY PAYMENTS FOR TIER-2 MEASURES

| | Per Affected Item |
|--|--------------------------|
| OSS Pre-Ordering | \$20 |
| Ordering | \$60 |
| Provisioning | \$300 |
| UNE Provisioning (Coordinated Customer Conversions) | \$875 |
| Maintenance and Repair | \$300 |
| UNE Maintenance and Repair | \$875 |
| Billing | \$1.00 |
| LNP | \$500 |
| IC Trunks | \$500 |
| Collocation | \$15,000 |

**AGREEMENT IMPLEMENTATION TEMPLATE (Residence)
for
Adelphia
BellSouth Standard Interconnection Agreement**

| | |
|----------------------------------|-----------------------------------|
| Agreement Effective Date: | Agreement Expiration Date: |
| Account Manager: | Account Manager Tel No: |

| Attachment Name/Number | Section Number | Version Date | Planned Activities |
|-------------------------|----------------|--------------|--------------------|
| Terms/Conditions PartA | 1 | 2/29/00 | |
| | 2 | 2/29/00 | |
| | 3 | 2/29/00 | |
| | 4 | 2/29/00 | |
| | 5 | 2/29/00 | |
| | 6 | 2/29/00 | |
| | 7 | 2/29/00 | |
| | 8 | 2/29/00 | |
| | 9 | 2/29/00 | |
| | 10 | 2/29/00 | |
| | 11 | 2/29/00 | |
| | 12 | 2/29/00 | |
| | 13 | 2/29/00 | |
| | 14 | 2/29/00 | |
| | 15 | 2/29/00 | |
| | 16 | 2/29/00 | |
| | 17 | 2/29/00 | |
| | 18 | 2/29/00 | |
| | 19 | 2/29/00 | |
| | 20 | 2/29/00 | |
| | 21 | 2/29/00 | |
| | 22 | 2/29/00 | |
| | 23 | 2/29/00 | |
| | 24 | 2/29/00 | |
| | 25 | 2/29/00 | |
| | 26 | 2/29/00 | |
| Terms/Conditions Part B | | 2/29/00 | |

**AGREEMENT IMPLEMENTATION TEMPLATE (Residence)
for
Adelphia
BellSouth Standard Interconnection Agreement**

| Attachment Name/Number | Section Number | Version Date | Planned Activities |
|-------------------------------------|-----------------------|---------------------|---------------------------|
| 1-Resale | 1 | 2/29/00 | |
| | 2 | 2/29/00 | |
| | 3 | 2/29/00 | |
| | 4 | 2/29/00 | |
| | 5 | 2/29/00 | |
| | 6 | 2/29/00 | |
| | 7 | 2/29/00 | |
| | 8 | 2/29/00 | |
| | 9 | 2/29/00 | |
| | 10 | 2/29/00 | |
| | 11 | 2/29/00 | |
| | 12 | 2/29/00 | |
| | 13 | 2/29/00 | |
| | Exhibit A | 2/29/00 | |
| Exhibit B | 2/29/00 | | |
| Exhibit C | 2/29/00 | | |
| Exhibit D | 2/29/00 | | |
| Exhibit E | 2/29/00 | | |
| Exhibit F | 2/29/00 | | |
| Exhibit G | 2/29/00 | | |
| | 2/29/00 | | |
| 2-Network Elements & Other Services | 1 | 2/29/00 | |
| | 2 | 2/29/00 | |
| | 3 | 2/29/00 | |
| | 4 | 2/29/00 | |
| | 5 | 2/29/00 | |
| | 6 | 2/29/00 | |
| | 7 | 2/29/00 | |
| | 8 | 2/29/00 | |
| | 9 | 2/29/00 | |

**AGREEMENT IMPLEMENTATION TEMPLATE (Residence)
for
Adelphia
BellSouth Standard Interconnection Agreement**

| Attachment Name/Number | Section Number | Version Date | Planned Activities |
|-------------------------------|-----------------------|---------------------|---------------------------|
| | 10 | 2/29/00 | |
| | 11 | 2/29/00 | |
| | 12 | 2/29/00 | |
| | 13 | 2/29/00 | |
| | 14 | 2/29/00 | |
| | 15 | 2/29/00 | |
| | 16 | 2/29/00 | |
| | 17 | 2/29/00 | |
| | Exhibit A | 2/29/00 | |
| | Exhibit B | 2/29/00 | |
| | Exhibit C | 2/29/00 | |
| 3-Local Interconnection | 1 | 2/29/00 | |
| | 2 | 2/29/00 | |
| | 3 | 2/29/00 | |
| | 4 | 2/29/00 | |
| | 5 | 2/29/00 | |
| | 6 | 2/29/00 | |
| | 7 | 2/29/00 | |
| | 8 | 2/29/00 | |
| | Exhibit A | 2/29/00 | |
| | Exhibit B | 2/29/00 | |
| | Exhibit C | 2/29/00 | |
| | Exhibit D | 2/29/00 | |
| | Exhibit E | 2/29/00 | |
| 4-Physical Collocation | 1 | 2/29/00 | |
| | 2 | 2/29/00 | |
| | 3 | 2/29/00 | |
| | 4 | 2/29/00 | |
| | 5 | 2/29/00 | |
| | 6 | 2/29/00 | |

**AGREEMENT IMPLEMENTATION TEMPLATE (Residence)
for
Adelphia
BellSouth Standard Interconnection Agreement**

| Attachment Name/Number | Section Number | Version Date | Planned Activities |
|--|-----------------------|---------------------|---------------------------|
| | 7 | 2/29/00 | |
| | 8 | 2/29/00 | |
| | 9 | 2/29/00 | |
| | 10 | 2/29/00 | |
| | 11 | 2/29/00 | |
| | 12 | 2/29/00 | |
| | 13 | 2/29/00 | |
| | 14 | 2/29/00 | |
| | Exhibit A | 2/29/00 | |
| | Exhibit B | 2/29/00 | |
| 5-Access to Numbers & Number Portability | 1 | 2/29/00 | |
| | 2 | 2/29/00 | |
| | 3 | 2/29/00 | |
| | 4 | 2/29/00 | |
| | 5 | 2/29/00 | |
| | 6 | 2/29/00 | |
| | 7 | 2/29/00 | |
| | 8 | 2/29/00 | |
| | Exhibit A | 2/29/00 | |
| 6-Ordering/Provisioning | 1 | 2/29/00 | |
| | 2 | 2/29/00 | |
| | 3 | 2/29/00 | |
| 7-Billing & Billing Accuracy Certification | 1 | 2/29/00 | |
| | 2 | 2/29/00 | |
| | 3 | 2/29/00 | |
| | 4 | 2/29/00 | |
| | 5 | 2/29/00 | |
| | 6 | 2/29/00 | |
| | 7 | 2/29/00 | |

**AGREEMENT IMPLEMENTATION TEMPLATE (Residence)
for
Adelphia
BellSouth Standard Interconnection Agreement**

| Attachment Name/Number | Section Number | Version Date | Planned Activities |
|-------------------------------|-----------------------|---------------------|---------------------------|
| | Exhibit A | 2/29/00 | |
| 8-ROW/Conduits/PoleAtt | 1 | 2/29/00 | |
| 9-Perf Measurement | Pre-Ordering | 2/29/00 | |
| | Ordering | 2/29/00 | |
| | Provisioning | 2/29/00 | |
| | Maint/Repair | 2/29/00 | |
| | Billing | 2/29/00 | |
| | Opr Svcs/DA | 2/29/00 | |
| | E911 | 2/29/00 | |
| | Trunk Grp Perf | 2/29/00 | |
| | Collocation | 2/29/00 | |
| | Appendix A | 2/29/00 | |
| | Appendix B | 2/29/00 | |
| | Appendix C | 2/29/00 | |
| 10-Executive Summary | | 2/29/00 | |
| | | 2/29/00 | |
| 11-Disaster Recovery | | 2/29/00 | |
| | | 2/29/00 | |
| | | | |
| | | | |

AGREEMENT IMPLEMENTATION TEMPLATE (Business)
for
Adelphia
BellSouth Standard Interconnection Agreement

| | |
|----------------------------------|-----------------------------------|
| Agreement Effective Date: | Agreement Expiration Date: |
| Account Manager: | Account Manager Tel No: |

| Attachment Name | Section No. | Version Date | Planned Activities |
|-------------------------|-------------|--------------|--------------------|
| Terms/Conditions PartA | 1 | | |
| | 2 | | |
| | 3 | | |
| | 4 | | |
| | 5 | | |
| | 6 | | |
| | 7 | | |
| | 8 | | |
| | 9 | | |
| | 10 | | |
| | 11 | | |
| | 12 | | |
| | 13 | | |
| | 14 | | |
| | 15 | | |
| | 16 | | |
| | 17 | | |
| | 18 | | |
| | 19 | | |
| | 20 | | |
| | 21 | | |
| | 22 | | |
| | 23 | | |
| | 24 | | |
| | 25 | | |
| | 26 | | |
| Terms/Conditions Part B | | | |

AGREEMENT IMPLEMENTATION TEMPLATE (Business)
for
Adelphia
BellSouth Standard Interconnection Agreement

| Attachment Name | Section No. | Version Date | Planned Activities |
|-------------------------------------|--------------------|---------------------|---------------------------|
| 1-Resale | 1 | | |
| | 2 | | |
| | 3 | | |
| | 4 | | |
| | 5 | | |
| | 6 | | |
| | 7 | | |
| | 8 | | |
| | 9 | | |
| | 10 | | |
| | 11 | | |
| | 12 | | |
| | 13 | | |
| | Exhibit A | | |
| | Exhibit B | | |
| | Exhibit C | | |
| | Exhibit D | | |
| | Exhibit E | | |
| | Exhibit F | | |
| | Exhibit G | | |
| | Exhibit H | | |
| 2-Network Elements & Other Services | 1 | | |
| | 2 | | |
| | 3 | | |
| | 4 | | |
| | 5 | | |
| | 6 | | |
| | 7 | | |
| | 8 | | |
| | 9 | | |

AGREEMENT IMPLEMENTATION TEMPLATE (Business)
for
Adelphia
BellSouth Standard Interconnection Agreement

| Attachment Name | Section No. | Version Date | Planned Activities |
|-------------------------|--------------------|---------------------|---------------------------|
| | 10 | | |
| | 11 | | |
| | 12 | | |
| | 13 | | |
| | 14 | | |
| | 15 | | |
| | 16 | | |
| | 17 | | |
| | Exhibit A | | |
| | Exhibit B | | |
| | Exhibit C | | |
| 3-Local Interconnection | 1 | | |
| | 2 | | |
| | 3 | | |
| | 4 | | |
| | 5 | | |
| | 6 | | |
| | 7 | | |
| | 8 | | |
| | Exhibit A | | |
| 4-Physical Collocation | 1 | | |
| | 2 | | |
| | 3 | | |
| | 4 | | |
| | 5 | | |
| | 6 | | |
| | 7 | | |
| | 8 | | |
| | 9 | | |
| | 10 | | |

AGREEMENT IMPLEMENTATION TEMPLATE (Business)
for
Adelphia
BellSouth Standard Interconnection Agreement

| Attachment Name | Section No. | Version Date | Planned Activities |
|--|--------------------|---------------------|---------------------------|
| | 11 | | |
| | 12 | | |
| | 13 | | |
| | 14 | | |
| | Exhibit A | | |
| | Exhibit B | | |
| 5-Access to Numbers & Number Portability | 1 | | |
| | 2 | | |
| | 3 | | |
| | 4 | | |
| | 5 | | |
| | 6 | | |
| | 7 | | |
| | 8 | | |
| | Exhibit A | | |
| 6-Ordering/Provisioning | 1 | | |
| | 2 | | |
| | 3 | | |
| 7-Billing & Billing Accuracy Certification | 1 | | |
| | 2 | | |
| | 3 | | |
| | 4 | | |
| | 5 | | |
| | 6 | | |
| | 7 | | |
| | Exhibit A | | |
| 8-ROW/Conduits/PoleAtt | 1 | | |
| 9-Perf Measurement | Pre-Ordering | | |
| | Ordering | | |

AGREEMENT IMPLEMENTATION TEMPLATE (Business)
for
Adelphia
BellSouth Standard Interconnection Agreement

| Attachment Name | Section No. | Version Date | Planned Activities |
|------------------------|--------------------|---------------------|---------------------------|
| | Provisioning | | |
| | Maint/Repair | | |
| | Billing | | |
| | Opr Svcs/DA | | |
| | E911 | | |
| | Trunk Grp Perf | | |
| | Collocation | | |
| | Appendix A | | |
| | Appendix B | | |
| | Appendix C | | |

Attachment 11
BellSouth Disaster Recovery Plan

***2000
BELLSOUTH
DISASTER RECOVERY PLANNING***

For

CLECS

CONTENTS

| | <u>PAGE</u> |
|---|--------------------|
| 1.0 Purpose | 4 |
| 2.0 Single Point of Contact | 4 |
| 3.0 Identifying the Problem | 4 |
| 3.1 Site Control | 5 |
| 3.2 Environmental Concerns | 6 |
| 4.0 The Emergency Control Center (ECC) | 6 |
| 5.0 Recovery Procedures | 7 |
| 5.1 CLEC Outage | 7 |
| 5.2 BellSouth Outage | 7 |
| 5.2.1 Loss of Central Office | 8 |
| 5.2.2 Loss of a Central Office with Serving Wire Center Functions | 8 |
| 5.2.3 Loss of a Central Office with Tandem Functions | 8 |
| 5.2.4 Loss of a Facility Hub | 9 |
| 5.3 Combined Outage (CLEC and BellSouth Equipment) | 9 |
| 6.0 T1 Identification Procedures | 9 |
| 7.0 Acronyms | 10 |

1.0 PURPOSE

In the unlikely event of a disaster occurring that affects BellSouth's long-term ability to deliver traffic to a Competitive Local Exchange Carrier (CLEC), general procedures have been developed to hasten the recovery process. Since each location is different and could be affected by an assortment of potential problems, a detailed recovery plan is impractical. However, in the process of reviewing recovery activities for specific locations, some basic procedures emerge that appear to be common in most cases.

These general procedures should apply to any disaster that affects the delivery of traffic for an extended time period. Each CLEC will be given the same consideration during an outage and service will be restored as quickly as possible.

This document will cover the basic recovery procedures that would apply to every CLEC.

2.0 SINGLE POINT OF CONTACT

When a problem is experienced, regardless of the severity, the BellSouth Network Management Center (NMC) will observe traffic anomalies and begin monitoring the situation. Controls will be appropriately applied to insure the sanity of BellSouth's network; and, in the event that a switch or facility node is lost, the NMC will attempt to circumvent the failure using available reroutes.

BellSouth's NMC will remain in control of the restoration efforts until the problem has been identified as being a long-term outage. At that time, the NMC will contact BellSouth's Emergency Control Center (ECC) and relinquish control of the recovery efforts. Even though the ECC may take charge of the situation, the NMC will continue to monitor the circumstances and restore traffic as soon as damaged network elements are revitalized.

The telephone number for the BellSouth Network Management Center in Atlanta, as published in Telcordia's National Network Management Directory, is 404-321-2516.

3.0 IDENTIFYING THE PROBLEM

During the early stages of problem detection, the NMC will be able to tell which CLECs are affected by the catastrophe. Further analysis and/or first hand observation will determine if the disaster has affected CLEC equipment only; BellSouth equipment only or a combination. The initial restoration activity will be largely determined by the equipment that is affected.

Once the nature of the disaster is determined and after verifying the cause of the problem, the NMC will initiate reroutes and/or transfers that are jointly agreed upon by the affected CLECs' Network Management Center and the BellSouth NMC. The type and percentage of controls used will depend upon available network capacity. Controls necessary to stabilize the situation will be invoked and the NMC will attempt to re-establish as much traffic as possible.

For long term outages, recovery efforts will be coordinated by the Emergency Control Center (ECC). Traffic controls will continue to be applied by the NMC until facilities are re-established. As equipment is made available for service, the ECC will instruct the NMC to begin removing the controls and allow traffic to resume.

3.1 SITE CONTROL

In the total loss of building use scenario, what likely exists will be a smoking pile of rubble. This rubble will contain many components that could be dangerous. It could also contain any personnel on the premises at the time of the disaster. For these reasons, the local fire marshal with the assistance of the police will control the site until the building is no longer a threat to surrounding properties and the companies have secured the site from the general public.

During this time, the majority owner of the building should be arranging for a demolition contractor to mobilize to the site with the primary objective of reaching the cable entrance facility for a damage assessment. The results of this assessment would then dictate immediate plans for restoration, both short term and permanent.

In a less catastrophic event, i.e., the building is still standing and the cable entrance facility is usable, the situation is more complex. The site will initially be controlled by local authorities until the threat to adjacent property has diminished. Once the site is returned to the control of the companies, the following events should occur.

An initial assessment of the main building infrastructure systems (mechanical, electrical, fire & life safety, elevators, and others) will establish building needs. Once these needs are determined, the majority owner should lead the building restoration efforts. There may be situations where the site will not be totally restored within the confines of the building. The companies must individually determine their needs and jointly assess the cost of permanent restoration to determine the overall plan of action.

Multiple restoration trailers from each company will result in the need for designated space and installation order. This layout and control is required to maximize the amount of restoration equipment that can be placed at the site, and the priority of placements.

Care must be taken in this planning to insure other restoration efforts have logistical access to the building. Major components of telephone and building equipment will need to be removed and replaced. A priority for this equipment must also be jointly established to facilitate overall site restoration. (Example: If the AC switchgear has sustained damage, this would be of the highest priority in order to regain power, lighting, and HVAC throughout the building.)

If the site will not accommodate the required restoration equipment, the companies would then need to quickly arrange with local authorities for street closures, rights of way or other possible options available.

3.2 ENVIRONMENTAL CONCERNS

In the worse case scenario, many environmental concerns must be addressed. Along with the police and fire marshal, the state environmental protection department will be on site to monitor the situation.

Items to be concerned with in a large central office building could include:

1. Emergency engine fuel supply. Damage to the standby equipment and the fuel handling equipment could have created "spill" conditions that have to be handled within state and federal regulations.
2. Asbestos containing materials that may be spread throughout the wreckage. Asbestos could be in many components of building, electrical, mechanical, outside plant distribution, and telephone systems.
3. Lead and acid. These materials could be present in potentially large quantities depending upon the extent of damage to the power room.
4. Mercury and other regulated compounds resident in telephone equipment.
5. Other compounds produced by the fire or heat.

Once a total loss event occurs at a large site, local authorities will control immediate clean up (water placed on the wreckage by the fire department) and site access.

At some point, the companies will become involved with local authorities in the overall planning associated with site clean up and restoration. Depending on the clean up approach taken, delays in the restoration of several hours to several days may occur.

In a less severe disaster, items listed above are more defined and can be addressed individually depending on the damage.

In each case, the majority owner should coordinate building and environmental restoration as well as maintain proper planning and site control.

4.0 THE EMERGENCY CONTROL CENTER (ECC)

The ECC is located in the Colonnade Building in Birmingham, Alabama. During an emergency, the ECC staff will convene a group of pre-selected experts to inventory the damage and initiate corrective actions. These experts have regional access to BellSouth's personnel and equipment and will assume control of the restoration activity anywhere in the nine-state area.

In the past, the ECC has been involve with restoration activities resulting from hurricanes, ice storms and floods. They have demonstrated their capabilities during these calamities as well as

during outages caused by human error or equipment failures. This group has an excellent record of restoring service as quickly as possible.

During a major disaster, the ECC may move emergency equipment to the affected location, direct recovery efforts of local personnel and coordinate service restoration activities with the CLECs. The ECC will attempt to restore service as quickly as possible using whatever means is available; leaving permanent solutions, such as the replacement of damaged buildings or equipment, for local personnel to administer.

Part of the ECC's responsibility, after temporary equipment is in place, is to support the NMC efforts to return service to the CLECs. Once service has been restored, the ECC will return control of the network to normal operational organizations. Any long-term changes required after service is restored will be made in an orderly fashion and will be conducted as normal activity.

5.0 RECOVERY PROCEDURES

The nature and severity of any disaster will influence the recovery procedures. One crucial factor in determining how BellSouth will proceed with restoration is whether or not BellSouth's equipment is incapacitated. Regardless of who's equipment is out of service, BellSouth will move as quickly as possible to aid with service recovery; however, the approach that will be taken may differ depending upon the location of the problem.

5.1 CLEC OUTAGE

For a problem limited to one CLEC (or a building with multiple CLECs), BellSouth has several options available for restoring service quickly. For those CLECs that have agreements with other CLECs, BellSouth can immediately start directing traffic to a provisional CLEC for completion. This alternative is dependent upon BellSouth having concurrence from the affected CLECs.

Whether or not the affected CLECs have requested a traffic transfer to another CLEC will not impact BellSouth's resolve to re-establish traffic to the original destination as quickly as possible.

5.2 BELLSOUTH OUTAGE

Because BellSouth's equipment has varying degrees of impact on the service provided to the CLECs, restoring service from damaged BellSouth equipment is different. The outage will probably impact a number of Carriers simultaneously. However, the ECC will be able to initiate immediate actions to correct the problem.

A disaster involving any of BellSouth's equipment locations could impact the CLECs, some more than others. A disaster at a Central Office (CO) would only impact the delivery of traffic to and from that one location, but the incident could affect many Carriers. If the Central Office is a Serving Wire Center (SWC), then traffic from the entire area to those Carriers served from that switch would also be impacted. If the switch functions as an Access Tandem, or there is a tandem in the building, traffic from every CO to every CLEC could be interrupted. A disaster that destroys a facility hub could disrupt various traffic flows, even though the switching equipment may be unaffected.

The NMC would be the first group to observe a problem involving BellSouth's equipment. Shortly after a disaster, the NMC will begin applying controls and finding re-routes for the

completion of as much traffic as possible. These reroutes may involve delivering traffic to alternate Carriers upon receiving approval from the CLECs involved. In some cases, changes in translations will be required. If the outage is caused by the destruction of equipment, then the ECC will assume control of the restoration.

5.2.1 Loss of a Central Office

When BellSouth loses a Central Office, the ECC will

- a) Place specialists and emergency equipment on notice;
- b) Inventory the damage to determine what equipment and/or functions are lost;
- c) Move containerized emergency equipment and facility equipment to the stricken area, if necessary;
- d) Begin reconnecting service for Hospitals, Police and other emergency agencies; and
- e) Begin restoring service to CLECs and other customers.

5.2.2 Loss of a Central Office with Serving Wire Center Functions

The loss of a Central Office that also serves as a Serving Wire Center (SWC) will be restored as described in section 5.2.1.

5.2.3 Loss of a Central Office with Tandem Functions

When BellSouth loses a Central Office building that serves as an Access Tandem and as a SWC, the ECC will

- a) Place specialists and emergency equipment on notice;
- b) Inventory the damage to determine what equipment and/or functions are lost;
- c) Move containerized emergency equipment and facility equipment to the stricken area, if necessary;
- d) Begin reconnecting service for Hospitals, Police and other emergency agencies;
- e) Re-direct as much traffic as possible to the alternate access tandem (if available) for delivery to those CLECs utilizing a different location as a SWC;
- f) Begin aggregating traffic to a location near the damaged building. From this location, begin re-establishing trunk groups to the CLECs for the delivery of traffic normally found on the direct trunk groups. (This aggregation point may be the alternate access tandem location or another CO on a primary facility route.)
- g) Begin restoring service to CLECs and other customers.

5.2.4 Loss of a Facility Hub

In the event that BellSouth loses a facility hub, the recovery process is much the same as above. Once the NMC has observed the problem and administered the appropriate controls, the ECC will assume authority for the repairs. The recovery effort will include

- a) Placing specialists and emergency equipment on notice;
- b) Inventorying the damage to determine what equipment and/or functions are lost;
- c) Moving containerized emergency equipment to the stricken area, if necessary;
- d) Reconnecting service for Hospitals, Police and other emergency agencies; and
- e) Restoring service to CLECs and other customers. If necessary, BellSouth will aggregate the traffic at another location and build temporary facilities. This alternative would be viable for a location that is destroyed and building repairs are required.

5.3 COMBINED OUTAGE (CLEC AND BELLSOUTH EQUIPMENT)

In some instances, a disaster may impact BellSouth's equipment as well as the CLECs'. This situation will be handled in much the same way as described in section 5.2.3. Since BellSouth and the CLECs will be utilizing temporary equipment, close coordination will be required.

6.0 T1 IDENTIFICATION PROCEDURES

During the restoration of service after a disaster, BellSouth may be forced to aggregate traffic for delivery to a CLEC. During this process, T1 traffic may be consolidated onto DS3s and may become unidentifiable to the Carrier. Because resources will be limited, BellSouth may be forced to "package" this traffic entirely differently than normally received by the CLECs. Therefore, a method for identifying the T1 traffic on the DS3s and providing the information to the Carriers is required.

7.0 ACRONYMS

- CO - Central Office (BellSouth)
- DS3 - Facility that carries 28 T1s (672 circuits)
- ECC - Emergency Control Center (BellSouth)
- CLEC - Competitive Local Exchange Carrier
- NMC - Network Management Center
- SWC - Serving Wire Center (BellSouth switch)
- T1 - Facility that carries 24 circuits

Hurricane Information

During a hurricane, BellSouth will make every effort to keep CLECs updated on the status of our network. Information centers will be set up throughout BellSouth Telecommunications. These centers are not intended to be used for escalations, but rather to keep the CLEC informed of network related issues, area damages and dispatch conditions, etc.

Hurricane-related information can also be found on line at http://www.interconnection.bellsouth.com/network/disaster/dis_resp.htm. Information concerning Mechanized Disaster Reports can also be found at this website by clicking on CURRENT MDR REPORTS or by going directly to <http://www.interconnection.bellsouth.com/network/disaster/mdrs.htm>.

BST Disaster Management Plan

BellSouth maintenance centers have geographical and redundant communication capabilities. In the event of a disaster removing any maintenance center from service another geographical center would assume maintenance responsibilities. The contact numbers will not change and the transfer will be transparent to the CLEC.

Attachment 12
Bona Fide Request/New Business Request

Bona Fide Request/New Business Request Process for Further Unbundling

- 1.1 BellSouth shall, upon request of Adelphia, provide to Adelphia access to its network elements at any technically feasible point for the provision of Adelphia's telecommunications service in accordance with applicable law and FCC rules and orders. Any request by Adelphia for access to a network element, interconnection option, or for the provisioning of any service or product that is not already available pursuant to this Agreement, including Section 1.2 below, shall be treated as a Bona Fide Request/New Business Request, and shall be submitted to BellSouth pursuant to the Bona Fide Request/New Business Request process set forth following.
- 1.2 BFR Not Required. Where the FCC or Commission, in a generic order, has required or shall require BellSouth to offer a network element, interconnection option, or service not covered in this Agreement, BellSouth shall offer to Adelphia said network element, interconnection option, or service in the same fashion as required by the generic proceeding and without submission of a BFR. If BellSouth provides any network element, interconnection option, or service that is not identified in this Agreement to itself, to any BellSouth affiliate, or to any other telecommunications carrier, BellSouth shall make available to Adelphia, upon Adelphia's request, and without submission of a BFR, the same network element, interconnection option, or service at parity. The Parties agree to amend the Agreement to include any rates, terms and conditions for any new network element, interconnection option, or service that BellSouth is required to make available to Adelphia under this section.
- 1.3 A Bona Fide Request/New Business Request shall be submitted in writing to Adelphia's Account Manager by Adelphia and shall specifically identify the requested service date, technical requirements, space requirements and/or such specifications that clearly define the request such that BellSouth has sufficient information to analyze and prepare a response. Such a request also shall include Adelphia's designation of the request as being (i) pursuant to the Telecommunications Act of 1996 or (ii) pursuant to the needs of the business.
- 1.4 To the extent possible, BellSouth will utilize information from previously developed BFRs to address similar arrangements in order to shorten the response times for the currently requested BFR and to decrease the development costs for the currently requested BFR. In the event Adelphia has submitted a BFR for a

network element, interconnection option, or service and BellSouth determines in accordance with the provisions of this Section that the BFR is technically feasible, the Parties agree that Adelphia's subsequent request or order for the identical type of network element, interconnection option, or service shall not be subject to the BFR process. To the extent BellSouth has previously deployed an identical network element, interconnection option, or service under a previous BFR for itself or any other carrier, a subsequent BFR is not required. However, BellSouth may require Adelphia to reimburse the initial requesting carrier a pro rata share of the development costs as defined below. Similarly, if BellSouth or another CLEC avoids development costs because Adelphia has already paid such costs for a particular network element, interconnection option, or service, then BellSouth shall reimburse Adelphia a pro rata share of the development costs paid. For purposes of this Section, an "identical" request shall be one that is materially identical to a previous request with respect to the information provided.

- 1.5 BellSouth acknowledgment. Within five (5) business days of receipt of a BFR, BellSouth shall acknowledge in writing its receipt and identify its single point of contact responsible for responding to the BFR and shall request any additional information needed to process the BFR. Within five (5) business days of receipt by BellSouth of a BFR from Adelphia, BellSouth agrees to confer with Adelphia to discuss the BFR to ensure that: (i) BellSouth properly understands Adelphia's BFR, and (ii) to inform Adelphia of the existence of any similar BFRs made by other parties. Notwithstanding the foregoing, BellSouth may request additional information from Adelphia at any time during the processing of the BFR. If BellSouth claims, in response to a BFR made under this Section, that it cannot offer a particular network element, interconnection option, or service because it is technically infeasible, BellSouth must specify in detail which technical specifications cannot be met.
- 1.6 Preliminary Analysis delivery. Unless otherwise agreed by both Parties in writing, within thirty (30) calendar days of its receipt of a BFR, BellSouth shall provide to Adelphia a Preliminary Analysis of the BFR. If BellSouth determines that it is not able to provide Adelphia a Preliminary Analysis within thirty (30) calendar days of BellSouth's receipt of the BFR, BellSouth will inform Adelphia as soon as practicable. Adelphia and BellSouth will then determine a mutually agreeable date for delivery of the Preliminary Analysis. Within five (5) business days of Adelphia's receipt of the BellSouth Preliminary Analysis and upon Adelphia's request, BellSouth

agrees to confer with Adelphia to discuss BellSouth's Preliminary Analysis.

- 1.7 Preliminary Analysis details. The Preliminary Analysis will state whether BellSouth can meet Adelphia's requirements and shall include BellSouth's proposed price (plus or minus 25 percent) and the date the BFR can be met. If BellSouth cannot provide the network element, interconnection option, or service by the requested date, it shall provide an alternative proposed date together with a detailed explanation as to why BellSouth is not able to meet Adelphia's requested date. The Preliminary Analysis also will include a detailed breakdown of the costs supporting the proposed price, including the development costs, as defined below, necessary to complete Adelphia's BFR. BellSouth also shall indicate in the Preliminary Analysis its agreement or disagreement with Adelphia's designation of the BFR as an obligation under the Telecommunications Act of 1996. If BellSouth does not agree with Adelphia's designation, it may use the Dispute Resolution process set forth in Section 12. In no event, however, shall any dispute delay BellSouth's processing of the Request.
- 1.8 Notice to proceed. After providing the Preliminary Analysis to Adelphia, BellSouth shall proceed with Adelphia's BFR upon receipt of Adelphia's written "notice to proceed." This "notice to proceed" shall not be construed by BellSouth as a waiver of Adelphia's right to invoke any dispute resolution process as set forth in Section 12 of the General Terms and Conditions as to any issue, including BellSouth's proposed price, the reasonable, demonstrable, and actual costs incurred in the event of Adelphia's cancellation of a BFR, or the amount of development costs paid. All payments are subject to adjustment according to the outcome of the dispute resolution process. In no event shall any dispute delay BellSouth proceeding with completing the BFR.
- 1.9 Development costs. After receipt and review of BellSouth's Preliminary Analysis, if Adelphia decides to proceed, Adelphia agrees to pay the fixed amount identified in the Preliminary Analysis for the initial work required to develop the project plan, create the design parameters, and establish all activities and resources required to complete the BFR. These costs will be referred to as "development costs." The development costs identified in the Preliminary Analysis are fixed. Adelphia will begin processing the payment of development costs at the time it issues the written "notice to proceed" with payment due to BellSouth within 15 days of the issuance of the notice to proceed.

- 1.10 Interim payment in the event of price dispute. In the event of a dispute over payments made by Adelphia or requested by BellSouth, including development costs and any interim progress payment, upon BellSouth's written request, Adelphia agrees to negotiate an interim lump sum progress payment to compensate BellSouth for its reasonable, demonstrable and actual costs incurred in processing Adelphia's BFR. The interim lump sum progress payment shall be calculated by determining the average between BellSouth's proposed price and Adelphia's estimate of the price for processing its BFR. Adelphia agrees to pay 50% of this amount as the interim lump sum progress payment. If Adelphia's proposed price is less than 50% of BellSouth's proposed price, the average shall be calculated by assuming that Adelphia's price is exactly 50% of BellSouth's proposed price.
- 1.11 Firm quote delivery. As soon as possible, but in no event later than sixty-five (65) calendar days after receipt of the Request, BellSouth shall provide Adelphia with a firm BFR response that will include, at a minimum, the firm availability date, the installation intervals, a binding price quote, and a final detailed breakdown of all costs supporting the final price.
- 1.12 Acceptance or rejection of firm quote. Within thirty (30) calendar days after receipt of the firm BFR response from BellSouth, Adelphia will notify BellSouth in writing of its acceptance or rejection of BellSouth's proposal. If BellSouth receives no response to the firm quote from Adelphia within the thirty day time frame, BellSouth shall issue a written request for confirmation that Adelphia does not wish to proceed with the BFR. If BellSouth receives no response from Adelphia within five (5) calendar days of its written request for confirmation, BellSouth may consider the BFR cancelled. Adelphia agrees to pay BellSouth the reasonable, demonstrable, and actual costs directly related to complying with Adelphia's BFR up to the date of cancellation.
- 1.13 Pricing Principles. Unless Adelphia agrees otherwise, all proposed prices shall be derived in accordance with the Act and any applicable FCC and Commission rules and regulations. Payments for services purchased under a BFR will be made as specified in this Agreement, unless otherwise agreed to by Adelphia.
- 1.14 Amendment. Upon Adelphia's acceptance of the firm quote by BellSouth, the Parties shall amend the Agreement to incorporate the network element, interconnection option, or service contemplated by the BFR. The amendment shall include all pertinent rates, terms and conditions and shall be filed with the

appropriate regulatory Commission pursuant to the requirements of the Act.

Amendment to
Agreement between
BellSouth Telecommunications, Inc. and
Adelphia Business Solutions of Kentucky, Inc.
dated May 2, 2001

Pursuant to this Amendment (the "Amendment"), BellSouth Telecommunications, Inc. ("BellSouth") and Adelphia Business Solutions of Kentucky, Inc. ("Adelphia") hereinafter referred to collectively as the "Parties" hereby agree to amend that certain Agreement (the "Agreement") between BellSouth and Adelphia dated May 2, 2001.

NOW THEREFORE, in consideration of the mutual provisions contained herein and other good and valuable consideration, the receipt and sufficiency of which are hereby acknowledged, BellSouth and Adelphia hereby covenant and agree as follows:

1. Attachment 3, Exhibit A, of the Agreement is hereby replaced with Attachment 3, Exhibit A attached hereto as ATTACHMENT 1 and made a part of this Amendment.
2. All of the other provisions of the Agreement, dated May 2, 2001 shall remain in full force and effect.
3. The Parties agree that either or both of the Parties is authorized to submit this Amendment to the respective state regulatory authorities for approval subject to Section 252(e) of the Federal Telecommunications Act of 1996.

IN WITNESS WHEREOF, the Parties hereto have caused this Amendment to be executed by their respective duly authorized representatives on the date indicated below.

BellSouth Telecommunications, Inc.

Adelphia Business Solutions
of Kentucky, Inc.

By: _____ Signature on file _____

By: _____ Signature on file _____

Name: _Gregory R. Follensbee_____

Name: __John B. Glicksman_____

Title: _____Senior Director_____

Title: __VP and General Counsel_____

Date: _____5/16/01 _____

Date: _5/12/01_____

BELLSOUTH/ADELPHIA RATES
LOCAL INTERCONNECTION

| DESCRIPTION | USOC | KY |
|---|-------|-------------|
| COMPENSATION | | |
| Year 2000 Per Mou Rate for Local Interconnection and ISP-Bound Traffic | N/A | \$0.0020 |
| Year 2001 Per Mou Rate for Local Interconnection and ISP-Bound Traffic | N/A | \$0.00175 |
| Year 2002 Per MouRate for Local Interconnection and ISP-Bound Traffic | N/A | \$0.0015 |
| LOCAL INTERCONNECTION (CALL TRANSPORT AND TERMINATION) FOR TRANSIT TRAFFIC AND MTA | | |
| End Office Switching, per mou | N/A | \$0.002562 |
| Tandem Switching, per mou | N/A | \$0.001096 |
| Tandem Intermediary Charge, per mou* | N/A | \$0.001096 |
| *(This charge is applicable only to transit traffic and is applied in addition to applicable switching and/or interconnection charges.) | | |
| TRUNK CHARGE | | |
| Interim charges, both non-recurring and recurring, associated with interconnecting trunk groups between BellSouth and Adelphia shall be as set forth in this Exhibit. At such time as BellSouth develops a final cost based rate for such interconnecting trunk groups, the Parties shall amend this agreement to include such final cost based rates and shall true up such charges in accordance with this Attachment | | |
| Installation Trunk Side Service - per DSO | | |
| NRC - 1st | TPP++ | \$334.09 |
| NRC - Add'l | TPP++ | \$57.12 |
| INTEROFFICE TRANSPORT | | |
| Common (Shared) Transport | | |
| Common (Shared) Transport per mile per mou | N/A | \$0.0000049 |
| Common (Shared) Transport Facilities Termination per mou | N/A | \$0.000426 |
| Interoffice Channel Transport - Dedicated - VG | | |
| Interoffice Transport - Dedicated - 2-wire VG | | |
| 2-Wire VG - per mile per month | 1L5XF | NA |
| 2-Wire VG - Facility Termination per month | 1L5XF | NA |
| NRC - 2-wire VG - Facility Termination -1st | 1L5XF | NA |
| NRC - 2-wire VG - Facility Termination - Add'l | 1L5XF | NA |
| NRC - 2-wire VG -Facility Termination - Disconnect Charge -1st | 1L5XF | NA |
| NRC - 2-wire VG - Facility Termination - Disconnect Charge -Add'l | 1L5XF | NA |
| NRC - Manual Svc Order, per LSR | SOMAN | NA |
| NRC - Manual Svc Order, per LSR disconnect | SOMAN | NA |
| NRC - Electronic Svc Order, per LSR | SOMEK | NA |
| NRC - Electronic Svc Order, per LSR disconnect | SOMEK | NA |
| NRC - 2-wire VG - Incremental Charge--Manual Svc Order - 1st | SOMAN | NA |
| NRC - 2-wire VG - Incremental Charge--Manual Svc Order - Add'l | SOMAN | NA |
| NRC - 2-wire VG - Incremental Charge--Manual Svc Order-Disconnect--1st | SOMAN | NA |
| NRC - 2-wire VG - Incremental Charge--Manual Svc Order-Disconnect--Add'l | SOMAN | NA |
| Interoffice Transport - Dedicated - 2 Wire VG - Kentucky & Mississippi | | |
| 2-Wire VG - per mile per month | 1L5NF | \$0.03 |
| 2-Wire VG - Facility Termination per month | 1L5NF | \$27.66 |
| NRC - 2-wire VG - Facility Termination -1st | 1L5NF | \$142.31 |

Version 2000: 7/24/00

BELLSOUTH/ADELPHIA RATES
LOCAL INTERCONNECTION

| DESCRIPTION | USOC | KY |
|--|-------|----------|
| NRC - 2-wire VG - Facility Termination - Add'l | 1L5NF | \$56.21 |
| NRC - 2-wire VG -Facility Termination - Disconnect Charge -1st | 1L5NF | NA |
| NRC - 2-wire VG - Facility Termination - Disconnect Charge -Add'l | 1L5NF | NA |
| NRC - Manual Svc Order, per LSR | SOMAN | \$19.99 |
| NRC - Manual Svc Order, per LSR disconnect | SOMAN | NA |
| NRC - Electronic Svc Order, per LSR | SOMEK | \$3.50 |
| NRC - Electronic Svc Order, per LSR disconnect | SOMEK | NA |
| NRC - 2-wire VG - Incremental Charge--Manual Svc Order - 1st | SOMAN | NA |
| NRC - 2-wire VG - Incremental Charge--Manual Svc Order - Add'l | SOMAN | NA |
| NRC - 2-wire VG - Incremental Charge--Manual Svc Order-Disconnect--1st | SOMAN | NA |
| NRC - 2-wire VG - Incremental Charge--Manual Svc Order-Disconnect--Add'l | SOMAN | NA |
| Interoffice Transport - Dedicated - DS0 - 56/64 KBPS | | |
| DS0 - per mile per month | 1L5XK | NA |
| DS0 - Facility Termination per month | 1L5XK | NA |
| NRC - DS0 - Facility Termination - 1st | 1L5XK | NA |
| NRC - DS0 - Facility Termination - Add'l | 1L5XK | NA |
| NRC - DS0 -Facility Termination - Disconnect Charge - 1st | 1L5XK | NA |
| NRC - DS0 - Facility Termination - Disconnect Charge - Add'l | 1L5XK | NA |
| NRC - Manual Svc Order, per LSR | SOMAN | NA |
| NRC - Manual Svc Order, per LSR disconnect | SOMAN | NA |
| NRC - Electronic Svc Order, per LSR | SOMEK | NA |
| NRC - Electronic Svc Order, per LSR disconnect | SOMEK | NA |
| NRC - DS0 -Incremental Charge--Manual Svc Order - 1st | SOMAN | NA |
| NRC -DS0 - Incremental Charge--Manual Svc Order - Add'l | SOMAN | NA |
| NRC - DS0 -Incremental Charge--Manual Svc Order-Disconnect--1st | SOMAN | NA |
| NRC - DS0 -Incremental Charge--Manual Svc Order-Disconnect--Add'l | SOMAN | NA |
| Interoffice Transport - Dedicated - DS0 - 56/64 KBPS - Kentucky & Mississippi | | |
| DS0 - per mile per month | 1L5NK | \$0.45 |
| DS0 - Facility Termination per month | 1L5NK | \$55.05 |
| NRC - DS0 - Facility Termination - 1st | 1L5NK | \$298.18 |
| NRC - DS0 - Facility Termination - Add'l | 1L5NK | \$231.23 |
| NRC - DS0 -Facility Termination - Disconnect Charge - 1st | 1L5NK | NA |
| NRC - DS0 - Facility Termination - Disconnect Charge - Add'l | 1L5NK | NA |
| NRC - Manual Svc Order, per LSR | SOMAN | \$19.99 |
| NRC - Manual Svc Order, per LSR disconnect | SOMAN | NA |
| NRC - Electronic Svc Order, per LSR | SOMEK | \$3.50 |
| NRC - Electronic Svc Order, per LSR disconnect | SOMEK | NA |
| NRC - DS0 -Incremental Charge--Manual Svc Order - 1st | SOMAN | NA |
| NRC -DS0 - Incremental Charge--Manual Svc Order - Add'l | SOMAN | NA |
| NRC - DS0 -Incremental Charge--Manual Svc Order-Disconnect--1st | SOMAN | NA |
| NRC - DS0 -Incremental Charge--Manual Svc Order-Disconnect--Add'l | SOMAN | NA |
| Interoffice Transport - Dedicated - DS1 | | |
| DS1 - per mile per month | 1L5XL | NA |

BELLSOUTH/ADELPHIA RATES
LOCAL INTERCONNECTION

| DESCRIPTION | USOC | KY |
|---|-------|----------|
| DS1 -Facility Termination per month | 1L5XL | NA |
| NRC - DS1-Facility Termination - 1st | 1L5XL | NA |
| NRC - DS1 - Facility Termination - Add'l | 1L5XL | NA |
| NRC - DS1 - Facility Termination - Disconnect Charge - 1st | 1L5XL | NA |
| NRC - DS1 - Facility Termination -Disconnect Charge - Add'l | 1L5XL | NA |
| NRC - Manual Svc Order, per LSR | SOMAN | NA |
| NRC - Manual Svc Order, per LSR disconnect | SOMAN | NA |
| NRC - Electronic Svc Order, per LSR | SOMEK | NA |
| NRC - Electronic Svc Order, per LSR disconnect | SOMEK | NA |
| NRC - DS1 - Incremental Charge--Manual Svc Order - 1st | SOMAN | NA |
| NRC -DS1 - Incremental Charge--Manual Svc Order - Add'l | SOMAN | NA |
| NRC - DS1 - Incremental Charge--Manual Svc Order-Disconnect--1st | SOMAN | NA |
| NRC - DS1 - Incremental Charge--Manual Svc Order-Disconnect--Add'l | SOMAN | NA |
| Interoffice Transport - Dedicated - DS1 - Kentucky & Mississippi | | |
| DS1 - per mile per month | 1L5NL | \$0.45 |
| DS1 -Facility Termination per month | 1L5NL | \$55.05 |
| NRC - DS1-Facility Termination - 1st | 1L5NL | \$298.18 |
| NRC - DS1 - Facility Termination - Add'l | 1L5NL | \$231.23 |
| NRC - DS1 - Facility Termination - Disconnect Charge - 1st | 1L5NL | NA |
| NRC - DS1 - Facility Termination -Disconnect Charge - Add'l | 1L5NL | NA |
| NRC - Manual Svc Order, per LSR | SOMAN | \$19.99 |
| NRC - Manual Svc Order, per LSR disconnect | SOMAN | NA |
| NRC - Electronic Svc Order, per LSR | SOMEK | \$3.50 |
| NRC - Electronic Svc Order, per LSR disconnect | SOMEK | NA |
| NRC - DS1 - Incremental Charge--Manual Svc Order - 1st | SOMAN | NA |
| NRC -DS1 - Incremental Charge--Manual Svc Order - Add'l | SOMAN | NA |
| NRC - DS1 - Incremental Charge--Manual Svc Order-Disconnect--1st | SOMAN | NA |
| NRC - DS1 - Incremental Charge--Manual Svc Order-Disconnect--Add'l | SOMAN | NA |
| Interoffice Transport - Dedicated - DS3 | | |
| DS3 - per mile per month | 1L5XM | NA |
| DS3 -Facility Termination per month | 1L5XM | NA |
| NRC - DS3 - Facility Termination -1st | 1L5XM | NA |
| NRC - DS3 - Facility Termination - Add'l | 1L5XM | NA |
| NRC - DS3 - Facility Termination - Disconnect Charge - 1st | 1L5XM | NA |
| NRC - DS3 - Facility Termination - Disconnect Charge - Add'l | 1L5XM | NA |
| NRC - Manual Svc Order, per LSR | SOMAN | NA |
| NRC - Manual Svc Order, per LSR disconnect | SOMAN | NA |
| NRC - Electronic Svc Order, per LSR | SOMEK | NA |
| NRC - Electronic Svc Order, per LSR disconnect | SOMEK | NA |
| NRC - DS3 - Incremental Charge--Manual Svc Order - 1st | SOMAN | NA |
| NRC - DS3 - Incremental Charge--Manual Svc Order - Add'l | SOMAN | NA |
| NRC - DS3 - Incremental Charge--Manual Svc Order-Disconnect--1st | SOMAN | NA |
| NRC - DS3 - Incremental Charge--Manual Svc Order-Disconnect--Add'l | SOMAN | NA |
| Interoffice Transport - Dedicated - DS3 - Kentucky & Mississippi | | |

BELLSOUTH/ADELPHIA RATES
LOCAL INTERCONNECTION

| DESCRIPTION | USOC | KY |
|---|-------|------------|
| DS3 - per mile per month | 1L5NM | \$12.06 |
| DS3 -Facility Termination per month | 1L5NM | \$1,112.02 |
| NRC - DS3 - Facility Termination -1st | 1L5NM | \$858.75 |
| NRC - DS3 - Facility Termination - Add'l | 1L5NM | \$524.95 |
| NRC - DS3 - Facility Termination - Disconnect Charge - 1st | 1L5NM | NA |
| NRC - DS3 - Facility Termination - Disconnect Charge - Add'l | 1L5NM | NA |
| NRC - Manual Svc Order, per LSR | SOMAN | \$19.99 |
| NRC - Manual Svc Order, per LSR disconnect | SOMAN | NA |
| NRC - Electronic Svc Order, per LSR | SOMEK | \$3.50 |
| NRC - Electronic Svc Order, per LSR disconnect | SOMEK | NA |
| NRC - DS3 - Incremental Charge--Manual Svc Order - 1st | SOMAN | NA |
| NRC - DS3 - Incremental Charge--Manual Svc Order - Add'l | SOMAN | NA |
| NRC - DS3 - Incremental Charge--Manual Svc Order-Disconnect--1st | SOMAN | NA |
| NRC - DS3 - Incremental Charge--Manual Svc Order-Disconnect--Add'l | SOMAN | NA |
| Local Channel - Dedicated | | |
| Local Channel - Dedicated - 2-Wire VG | | |
| Monthly Recurring per month | TEFV2 | \$22.26 |
| Zone 1 | TBD | NA |
| Zone 2 | TBD | NA |
| Zone 3 | TBD | NA |
| Zone 4 | TBD | NA |
| NRC - STS-1 - Facility Termination - 1st | TEFV2 | \$585.15 |
| NRC - STS-1 - Facility Termination - Add'l | TEFV2 | \$98.53 |
| NRC - STS-1 - Facility Termination - Disconnect - 1st | TEFV2 | \$11.99 |
| NRC - STS-1 - Facility Termination - Disconnect - Add'l | TEFV2 | NA |
| NRC - Manual Svc Order, per LSR | SOMAN | \$19.99 |
| NRC - Manual Svc Order, per LSR disconnect | SOMAN | NA |
| NRC - Electronic Svc Order, per LSR | SOMEK | \$3.50 |
| NRC - Electronic Svc Order, per LSR disconnect | SOMEK | NA |
| NRC - STS-1 - Incremental Charge--Manual Svc Order - 1st | SOMAN | NA |
| NRC - STS-1 - Incremental Charge--Manual Svc Order - Add'l | SOMAN | NA |
| NRC - STS-1 - Incremental Cost - Manual Svc. Order vs. Elect-Disconnect-1st | SOMAN | NA |
| Local Channel - Dedicated - 4-Wire VG | | |
| Monthly Recurring per month | TEFV4 | \$23.38 |
| Zone 1 | TBD | NA |
| Zone 2 | TBD | NA |
| Zone 3 | TBD | NA |
| Zone 4 | TBD | NA |
| NRC - 4-Wire VG - 1st | TEFV4 | \$585.15 |
| NRC - 4-Wire VG - Add'l | TEFV4 | \$98.53 |
| NRC - 4-Wire VG - Disconnect Chg - 1st | TEFV4 | NA |
| NRC - 4-Wire VG - Disconnect Chg - Add'l | TEFV4 | NA |
| NRC - Manual Svc Order, per LSR | SOMAN | \$19.99 |
| NRC - Manual Svc Order, per LSR disconnect | SOMAN | NA |
| NRC - Electronic Svc Order, per LSR | SOMEK | \$3.50 |

BELLSOUTH/ADELPHIA RATES
LOCAL INTERCONNECTION

| DESCRIPTION | USOC | KY |
|---|-------|------------|
| NRC - Electronic Svc Order, per LSR disconnect | SOMEK | NA |
| NRC - 4-Wire VG - Incremental Charge--Manual Svc Order - 1st | SOMAN | NA |
| NRC - 4-Wire VG - Incremental Charge--Manual Svc Order - Add'l | SOMAN | NA |
| Local Channel - Dedicated - DS1 | | |
| DS1 Monthly Recurring per month | TEFHG | \$43.80 |
| DS1 per mile per month | 1L5NC | \$0.00 |
| Zone 1 | TBD | NA |
| Zone 2 | TBD | NA |
| Zone 3 | TBD | NA |
| Zone 4 | TBD | NA |
| NRC - DS1 - 1st | TEFHG | \$538.95 |
| NRC - DS1 - Add'l | TEFHG | \$464.94 |
| NRC - DS1 - Disconnect Chg - 1st | TEFHG | NA |
| NRC - DS1 - Disconnect Chg - Add'l | TEFHG | NA |
| NRC - Manual Svc Order, per LSR | SOMAN | \$19.99 |
| NRC - Manual Svc Order, per LSR disconnect | SOMAN | NA |
| NRC - Electronic Svc Order, per LSR | SOMEK | \$3.50 |
| NRC - Electronic Svc Order, per LSR disconnect | SOMEK | NA |
| NRC - DS1 - Incremental Charge--Manual Svc Order - 1st | SOMAN | NA |
| NRC - DS1 - Incremental Charge--Manual Svc Order - Add'l | SOMAN | NA |
| Local Channel - Dedicated - DS3 | | |
| DS3 - per mile per month | 1L5NC | \$34.00 |
| DS3 - Facility Termination per month | TEFHJ | \$635.09 |
| NRC - DS3 - Facility Termination - 1st | TEFHJ | \$1,091.00 |
| NRC - DS3 - Facility Termination - Add'l | TEFHJ | \$661.23 |
| NRC - DS3 - Facility Termination - Disconnect - 1st | TEFHJ | NA |
| NRC - DS3 - Facility Termination - Disconnect - Add'l | TEFHJ | NA |
| NRC - Manual Svc Order, per LSR | SOMAN | \$19.99 |
| NRC - Manual Svc Order, per LSR disconnect | SOMAN | NA |
| NRC - Electronic Svc Order, per LSR | SOMEK | \$3.50 |
| NRC - Electronic Svc Order, per LSR disconnect | SOMEK | NA |
| NRC - DS3 -Incremental Charge--Manual Svc Order - 1st | SOMAN | NA |
| NRC - DS3 - Incremental Charge--Manual Svc Order - Add'l | SOMAN | NA |
| NRC - DS3 - Incremental Charge--Manual Svc Order-Disconnect -1st | SOMAN | NA |
| NRC - DS3 - Incremental Charge--Manual Svc Order-Disconnect-Add'l | SOMAN | NA |
| CHANNELIZATION | | |
| DS3 Channelization (DS3 to DS1) | | |
| per Channelized System (28 DS1) per month | SATCS | NA |
| NRC - 1st | SATCS | NA |
| NRC - Add'l | SATCS | NA |
| NRC -1st - Disconnect | SATCS | NA |
| NRC -Add'l - Disconnect | SATCS | NA |
| per Interface per month (COCI) | SATCO | NA |

Version 2006-724700

BELLSOUTH/ADELPHIA RATES
LOCAL INTERCONNECTION

| DESCRIPTION | USOC | KY |
|---|-------|----------|
| NRC - 1st | SATCO | NA |
| NRC - Add'l | SATCO | NA |
| NRC - Manual Svc Order, per LSR | SOMEK | NA |
| NRC - Manual Svc Order, per LSR disconnect | SOMAN | NA |
| NRC - Electronic Svc Order, per LSR | SOMAN | NA |
| NRC - Electronic Svc Order, per LSR disconnect | SOMAN | NA |
| Channel System - Incremental Cost - Manual Svc. Order vs. Electronic -1st | SOMAN | NA |
| Channel System - Incremental Cost - Manual Svc. Order vs. Electronic -Add'l | SOMAN | NA |
| DS3 Channelization (DS3 to DS1) - Kentucky & Mississippi | | |
| per Channelized System (28 DS1) per month | SATNS | \$303.33 |
| NRC - 1st | SATNS | NA |
| NRC - Add'l | SATNS | NA |
| NRC -1st - Disconnect | SATNS | \$8.52 |
| NRC -Add'l - Disconnect | SATNS | \$15.86 |
| per Interface per month (COCI) | SATCO | \$11.36 |
| NRC - 1st | SATCO | \$19.99 |
| NRC - Add'l | SATCO | NA |
| NRC - Manual Svc Order, per LSR | SOMAN | \$3.50 |
| NRC - Manual Svc Order, per LSR disconnect | SOMAN | NA |
| NRC - Electronic Svc Order, per LSR | SOMEK | NA |
| NRC - Electronic Svc Order, per LSR disconnect | SOMEK | NA |
| Channel System - Incremental Cost - Manual Svc. Order vs. Electronic -1st | SOMAN | NA |
| Channel System - Incremental Cost - Manual Svc. Order vs. Electronic -Add'l | SOMAN | NA |
| DS1 Channelization (DS1 to DS0) | | |
| per Channelized System (24 DS0) per month | SATC1 | NA |
| NRC - 1st | SATC1 | NA |
| NRC - Add'l | SATC1 | NA |
| NRC -1sr - Disconnect | SATC1 | NA |
| NRC -Add'l - Disconnect | SATC1 | NA |
| - Interface (COCI) | | |
| per OCU-DP(data) card per month (2.4-64kbs) | SATSA | NA |
| NRC - 1st | SATSA | NA |
| NRC - Add'l | SATSA | NA |
| per BRITE card per month | SATSA | NA |
| NRC - 1st | SATSA | NA |
| NRC - Add'l | SATSA | NA |
| per VG card per month (DS0) | SATSA | NA |
| NRC - 1st | SATSA | NA |
| NRC - Add'l | SATSA | NA |
| NRC - Manual Svc Order, per LSR | SOMAN | NA |
| NRC - Manual Svc Order, per LSR disconnect | SOMAN | NA |
| NRC - Electronic Svc Order, per LSR | SOMEK | NA |
| NRC - Electronic Svc Order, per LSR disconnect | SOMEK | NA |
| Channel System - Incremental Cost - Manual Svc. Order vs. Electronic -1st | SOMAN | NA |
| Channel System - Incremental Cost - Manual Svc. Order vs. Electronic -Add'l | SOMAN | NA |
| Incremental Cost-Manual Svc. Order vs. Elect -Disconnect - 1st | SOMAN | NA |
| Incremental Cost-Manual Svc. Order vs. Elect -Disconnect - Add'l | SOMAN | NA |

Version 2Q00: 7/24/00

BELLSOUTH/ADELPHIA RATES
LOCAL INTERCONNECTION

| DESCRIPTION | USOC | KY |
|--|--------|----------|
| DS1 Channelization (DS1 to DS0) - Kentucky & Mississippi | | |
| per Channelized System (24 DS0) per month | SASTN1 | \$200.01 |
| NRC - 1st | SASTN1 | \$302.82 |
| NRC - Add'l | SASTN1 | \$184.20 |
| NRC -1sr - Disconnect | SASTN1 | NA |
| NRC -Add'l - Disconnect | SASTN1 | NA |
| - Interface (COCI) | | |
| per OCU-DP(data) card per month (2.4-64kbs) | SATSA | \$2.94 |
| NRC - 1st | SATSA | \$15.86 |
| NRC - Add'l | SATSA | \$11.36 |
| per BRITE card per month | SATSA | \$4.04 |
| NRC - 1st | SATSA | \$15.86 |
| NRC - Add'l | SATSA | \$11.36 |
| per VG card per month (DS0) | SATSA | \$1.40 |
| NRC - 1st | SATSA | \$15.86 |
| NRC - Add'l | SATSA | \$11.36 |
| NRC - Manual Svc Order, per LSR | SOMAN | \$19.99 |
| NRC - Manual Svc Order, per LSR disconnect | SOMAN | NA |
| NRC - Electronic Svc Order, per LSR | SOMEK | \$3.50 |
| NRC - Electronic Svc Order, per LSR disconnect | SOMEK | NA |
| Channel System - Incremental Cost - Manual Svc. Order vs. Electronic -1st | SOMAN | NA |
| Channel System - Incremental Cost - Manual Svc. Order vs. Electronic -Add'l | SOMAN | NA |
| Incremental Cost-Manual Svc. Order vs. Elect -Disconnect - 1st | SOMAN | NA |
| Incremental Cost-Manual Svc. Order vs. Elect -Disconnect - Add'l | SOMAN | NA |
| | | |
| Local Interconnection Mid-Span Meet | | |
| Local Channel - Dedicated - DS1 | | |
| DS1 Monthly Recurring per month | TEFHG | \$21.90 |
| NRC - DS1 - 1st | TEFHG | \$269.48 |
| NRC - DS1 - Add'l | TEFHG | \$232.47 |
| NRC - DS1 - Disconnect Chg - 1st | TEFHG | NA |
| NRC - DS1 - Disconnect Chg - Add'l | TEFHG | NA |
| NRC - DS1 - Incremental Charge--Manual Svc Order - 1st | SOMAC | \$87.71 |
| NRC - DS1 - Incremental Charge--Manual Svc Order - Add'l | SOMAC | NA |
| NRC - DS1 - Incremental Charge--Manual Svc Order-Disconnect | SOMAC | NA |
| | | |
| | | |
| NOTES: | | |
| If no rate is identified in the contract, the rate for the specific service or function will be as set forth in applicable BellSouth tariff or as ne | | |

**AMENDMENT
TO THE
AGREEMENT BETWEEN
ADELPHIA BUSINESS SOLUTIONS OF KENTUCKY, INC.
AND
BELLSOUTH TELECOMMUNICATIONS, INC.
DATED AUGUST 21, 2000**

Pursuant to this Amendment, (the "Amendment"), Adelpia Business Solutions of Kentucky, Inc. ("Adelpia"), and BellSouth Telecommunications, Inc. ("BellSouth"), hereinafter referred to collectively as the "Parties," hereby agree to amend that certain Interconnection Agreement between the Parties dated August 21, 2000 ("Agreement").

WHEREAS, BellSouth and Adelpia entered into the Agreement on August 21, 2000,
and;

NOW THEREFORE, in consideration of the mutual provisions contained herein and other good and valuable consideration, the receipt and sufficiency of which are hereby acknowledged, the Parties hereby covenant and agree as follows:

1. The Parties agree to delete Section 5.4, Attachment 2 in its entirety and replace it with a new Section 5.4 incorporated herein below:
 - 5.4. Ordinarily Combined UNE Combinations
 - 5.4.1 BellSouth shall provide Ordinarily Combined UNE Combinations to Adelpia as new service in Alabama, where available, regardless of whether or not such network element combinations are Currently Combined. Ordinarily Combined UNE Combinations consist of a loop-transport combination, where the transport may consist of an Interoffice Channel, a Local Channel, or a Local Channel and an Interoffice Channel. These combinations may terminate to Adelpia's collocation; however collocation is not required. BellSouth does not connect Ordinarily Combined UNE Combinations to tariffed services.
 - 5.4.2 Rates
 - 5.4.2.1 The rates for Ordinarily Combined UNE Combinations, which replicate the architecture described in Section 5.3.4, shall be the sum of the recurring and non-recurring rates for that combination as set forth in Exhibit D of this Attachment.
 - 5.4.2.2 The rates for Ordinarily Combined UNE Combinations which do not replicate a combination described in Section 5.3.4, shall be the sum of the recurring rates and nonrecurring rates for the stand-alone network elements as set forth in Exhibit D of this Attachment.
 - 5.4.3 To the extent that Adelpia seeks to obtain other combinations of network elements that BellSouth ordinarily combines in its network which have not been specifically priced by the Commission when purchased in combined form, Adelpia, at its option, may request that such rates be determined pursuant to the BFR/NBR process set forth in this Agreement.
2. The Parties agree to amend Attachment 6 to add a new Section 3.7 incorporated herein below:

- 3.7 Service Date Advancement Charges (a.k.a Expedites). For Service Date Advancement requests by Adelphia, Service Date Advancement charges will apply for intervals less than the standard interval as outline in the BellSouth Product and Services Interval Guide. The charges as outline in BellSouth's FCC No. 1 Tariff Section 5, will apply as applicable.
3. Attachment 2, Exhibit D - Network Elements and Other Services of the Agreement is amended to delete Expedite Charges in its entirety and add UNE Service Date Advancement Charge rates, incorporated herein by reference as Exhibit 1 to this Amendment.
 4. This Amendment shall be deemed effective thirty (30) calendar days following the date of the last signature of both Parties.
 5. All of the other provisions of the Agreement, dated August 21, 2000, shall remain in full force and effect.
 6. Either or both of the Parties is authorized to submit this Amendment to the respective state regulatory authorities for approval subject to Section 252(e) of the Federal Telecommunications Act of 1996.

IN WITNESS WHEREOF, the Parties hereto have caused this Amendment to be executed by their respective duly authorized representatives on the date indicated below.

BellSouth Telecommunications, Inc.

Adelphia Business Solutions of Kentucky, Inc.

By:(Signature on File)

By: (Signature on File)

Name: Elizabeth R. A. Shiroishi

Name:John B. Glicksman

Title: Assistant Director,
Interconnection Services

Vice President &
Title: General Counsel

Date:09/16/2002

Date:09/10/2002

EXHIBIT 1

| UNBUNDLED NETWORK ELEMENTS - Kentucky | | | | | | | | | | Attachment: 2 | | Exhibit: D | | | | |
|---|--|---------|------|---------|-------|-----------|----------------------------------|--------------------------------------|--|--|---|---|-------|--------------|-------|-------------------------|
| CATEGORY | RATE ELEMENTS | Interim | Zone | BCS | USOC | RATES(\$) | Svc Order Submitted Elec per LSR | Svc Order Submitted Manually per LSR | Incremental Charge - Manual Svc Order vs. Electronic-1st | Incremental Charge - Manual Svc Order vs. Electronic-Add'l | Incremental Charge - Manual Svc Order vs. Electronic-Disc 1st | Incremental Charge - Manual Svc Order vs. Electronic-Disc Add'l | | | | |
| | | | | | | | | | | | | | Rec | Nonrecurring | | Nonrecurring Disconnect |
| | | | | | | | First | Add'l | First | Add'l | SOME | SOMAN | SOMAN | SOMAN | SOMAN | SOMAN |
| UNE SERVICE DATE ADVANCEMENT CHARGE | | | | | | | | | | | | | | | | |
| NOTE: The Expedite charge will be maintained commensurate with BellSouth's FCC No.1 Tariff, Section 5 as applicable. | | | | | | | | | | | | | | | | |
| | UNE Expedite Charge per Circuit or Line Assignable USOC, per Day | | | ALL UNE | SDASP | | 200.00 | | | | | | | | | |

**AMENDMENT
TO THE
AGREEMENT BETWEEN
ADELPHIA BUSINESS SOLUTIONS OF KENTUCKY, INC.
AND
BELLSOUTH TELECOMMUNICATIONS, INC.
DATED AUGUST 21, 2000**

Pursuant to this Amendment, (the "Amendment"), Adelphia Business Solutions of Kentucky, Inc. ("Adelphia"), and BellSouth Telecommunications, Inc. ("BellSouth"), hereinafter referred to collectively as the "Parties," hereby agree to amend that certain Interconnection Agreement between the Parties dated August 21, 2000 ("Agreement") and shall be effective January 1, 2003

WHEREAS, BellSouth and Adelphia entered into the Agreement on August 21, 2000, and;

NOW THEREFORE, in consideration of the mutual provisions contained herein and other good and valuable consideration, the receipt and sufficiency of which are hereby acknowledged, the Parties hereby covenant and agree as follows:

1. The Parties mutually agree to delete in its entirety Section 2, General Terms and Conditions of the Interconnection Agreement and replace with Section 2, incorporated herein as follows:

2. Term of the Agreement

- 2.1 The term of this Agreement shall be effective January 1, 2003, and shall expire on January 30, 2004 and shall apply to the BellSouth territory in the state of Kentucky.

Notwithstanding any prior agreement of the Parties, the rates, terms and conditions of this Agreement shall not be applied retroactively prior to the Effective Date

- 2.2 The Parties agree that by no earlier than two hundred seventy (270) days and no later than one hundred and eighty (180) days prior to the expiration of this Agreement, they shall commence negotiations for a new agreement to be effective beginning on the expiration date of this Agreement ("Subsequent Agreement").

- 2.3 If, within one hundred and thirty-five (135) days of commencing the negotiation referred to in Section 2.2 above, the Parties are unable to negotiate new terms, conditions and prices for a Subsequent Agreement, either Party may petition the Commission to establish appropriate terms, conditions and prices for the Subsequent Agreement pursuant to 47 U.S.C. 252.

- 2.4 If, as of the expiration of this Agreement, a Subsequent Agreement has not been executed by the Parties, this Agreement shall terminate. Upon termination of this Agreement, BellSouth shall continue to offer services to Adelphia pursuant to the terms, conditions and rates set forth in BellSouth's then current standard interconnection agreement. In the event that BellSouth's standard interconnection agreement becomes effective as between the Parties, the Parties may continue to negotiate a Subsequent Agreement or arbitrate disputed issues to reach a Subsequent Agreement as set forth in Section 2.3 above, and the terms of such Subsequent Agreement shall be effective as of the effective date as stated in the Subsequent Agreement.

2. The Parties hereby mutually agree to add Section 4.5 to Attachment 1 of the Interconnection Agreement incorporated herein as follows:

4.5 Service Jointly Provisioned with an Independent Company or Competitive Local Exchange Company Areas

4.5.1 BellSouth will in some instances provision resold services in accordance with the General Subscriber Services Tariff and Private Line Tariffs jointly with an Independent Company or other Competitive Local Exchange Carrier.

4.5.2 When Adelphia assumes responsibility for such service, all terms and conditions defined in the Tariff will apply for services provided within the BellSouth service area only.

4.5.3 Service terminating in an Independent Company or other Competitive Local Exchange Carrier area will be provisioned and billed by the Independent Company or other Competitive Local Exchange Carrier directly to Adelphia.

4.5.4 Adelphia must establish a billing arrangement with the Independent Company or other Competitive Local Exchange Carrier prior to assuming an end user account where such circumstances apply.

4.5.5 Specific guidelines regarding such services are available on BellSouth's website @ www.interconnection.bellsouth.com.

3. The Parties hereby mutually agree to delete Sections 4 and 5 to Attachment 2 of the Interconnection Agreement and replace with Section 5 incorporated herein as follows:
4. The Parties hereby mutually agree to delete Section 1.7 to Attachment 3 of the Interconnection Agreement and replace with Section 1.7 incorporated herein as follows:
 - 1.7 The Parties shall make available to each other one-way and two-way trunks for the reciprocal exchange of combined Local Traffic, ISP-bound Traffic and IntraLATA Toll Traffic. The Parties shall institute a bill and keep compensation plan under which neither Party will charge the other Party recurring and nonrecurring charges as set forth in Exhibit A associated with trunks and associated facilities for the exchange of traffic other than Transit Traffic. Each Party has the obligation to install the appropriate trunks and associated facilities on its respective side of the Point of Interface. Notwithstanding the foregoing, reciprocal compensation will be paid for the delivery of Local Traffic and ISP-bound Traffic in accordance with the terms of Section 6.1. Nothing in this Section 1.7 shall be deemed to eliminate or affect any lease-back arrangement where a Party, at its option and in lieu of installing facilities or trunks on its side of the Point of Interface, chooses to lease such facilities or trunks from the other Party for its originating traffic.
5. The Parties hereby mutually agree to add Section 1.8.1 to Attachment 3 of the Interconnection Agreement incorporated herein as follows:
 - 1.8.1 The facilities purchased pursuant to this Section 3 shall be ordered via the Access Service Request ("ASR") process.
6. The Parties hereby mutually agree to delete Section 2.3 and (1) of Section 2.3 to Attachment 3 of the Interconnection Agreement and replace with Section 2.3 and (1) of Section 2.3 incorporated herein as follows:
 - 2.3 Pursuant to Section 1.7 of this Attachment:
 - (1) All terms and conditions, as well as charges, both non-recurring and recurring, associated with interconnecting trunk groups and facilities between BellSouth and Adelphia are set forth in Exhibit A. In the event there is not an applicable rate element in Exhibit A, the

Parties shall be compensated at the provisioning Party's Commission filed and approved tariff rate for such element.

7. The Parties hereby mutually agree to delete Section 2.9.4 Attachment 3 of the Interconnection Agreement and replace with Section 2.9.4 incorporated herein as follows:

2.9.4 With MTA, for the delivery Adelpia oriented Local Traffic, ISP-bound Traffic and IntraLATA Toll Traffic, Adelpia will be assessed charges as specified in Exhibit A of this Attachment for the additional transport and tandem switching on an elemental basis in addition to the reciprocal compensation rate to which the parties have agreed in Section 6.1.2. Notwithstanding the foregoing, in the situation of tandem exhaust at any particular tandem, where the parties choose MTA as an alternative routing plan, the Parties will negotiate appropriate rates, terms and conditions for MTA.

8. The Parties hereby mutually agree to delete Section 4 to Attachment 3 of the Interconnection Agreement and replace with Section 4 incorporated herein as follows:

4. Parity in Ordering and Provisioning

Each Party shall provide interconnection ordering and provisioning services to the other Party that are equal to the ordering and provisioning services the Parties provide themselves, their affiliates and third parties.

9. The Parties hereby mutually agree to delete Section 6.1.2 through 6.1.3.3 to Attachment 3 of the Interconnection Agreement and replace with Section 6.1.2 through 6.1.3.4 incorporated herein as follows:

6.1.2 Nothing in this Agreement shall be construed to limit each Party's ability to designate the areas within which the Party's Customers may make calls which that Party rates as "local" in its Customer Tariffs.

Subject to the Parties agreement to the terms of Section 1.5 through 1.8, and Sections 2.9 through 2.9.6, the Parties will compensate each other on a mutual and reciprocal basis for the transport and termination of Local Traffic and ISP-bound Traffic at rates set forth in Exhibit A to this Attachment.

6.1.3 ISP-bound Traffic is defined as calls to an information service provider or Internet service provider (ISP) that are dialed by using a local dialing pattern (7 or 10 digits) by a calling party in one exchange to an ISP server or modem in the same exchange or other local calling area associated with the originating exchange as defined and specified in Section 3 of BellSouth's General Subscriber Service Tariff. ISP-bound Traffic is not Local Traffic subject to reciprocal compensation, but instead is information access traffic subject to the FCC's jurisdiction.

6.1.3.1 Notwithstanding the definitions of Local Traffic and ISP-bound traffic above, and pursuant to the FCC' Order on Remand and Report and Order in CC Docket 99-68 released April 27, 2001 (ISP Order on Remand), BellSouth and Adelpia agree to the rebuttable presumption that all combined circuit switched Local and ISP-bound Traffic delivered to BellSouth or Adelpia that exceeds a 3:1 ratio of terminating to originating traffic on a statewide basis shall be considered ISP-bound traffic for compensation purposes. BellSouth and Adelpia further agree to the rebuttable presumption that all combined circuit switched Local and ISP-bound Traffic delivered to BellSouth or Adelpia that does not exceed 3:1 ratio of terminating to originating traffic on a statewide basis shall be considered Local Traffic for compensation purposes.

- 6.1.3.2 For ISP-bound Traffic exchanged during the year 2002, compensation, at the rates set forth in Exhibit A of this Agreement, shall be billed by the terminating Party and paid by the originating Party on ISP-bound Traffic minutes up to a ceiling equal to a ten percent growth factor added to, on an annualized basis, the number of ISP-bound Traffic minutes exchanged during the first quarter of 2001, plus an additional ten percent growth.
- 6.1.3.3 For ISP-bound Traffic exchanged during the year 2003 and beyond, compensation, at the rates set forth in Exhibit A of this Agreement, shall be billed by the terminating Party to the originating Party on ISP-bound Traffic minutes up to a ceiling equal to the year 2002 ceiling.
- 6.1.3.4 Any ISP-bound Traffic that exceeds the minute of use caps described above shall be exchanged on a bill and keep basis, and no compensation shall be paid to the terminating Party therefor.
10. The Parties hereby mutually agree to delete Section 6.1.6.1, 6.2 and 6.2.1 to Attachment 3 of the Interconnection Agreement and replace with Section 6.1.6.1, 6.2 and 6.2.1 incorporated herein as follows:
- 6.1.6.1 To the extent Adelphia is unable to identify Virtual NXX traffic to BellSouth for Adelphia's operations in Kentucky, Louisiana, Tennessee and the Jacksonville, Florida LATA (the "Transition Areas"), and where BellSouth can determine with specificity that certain individual telephone numbers in an Adelphia NPA/NXX in the Transition Areas are terminating Virtual NXX traffic, then BellSouth may adjust the compensation paid to Adelphia in accordance with the compensation arrangement stated above, but only with respect to compensation due for traffic terminated to those identified numbers. BellSouth shall make appropriate adjustments once Adelphia provides sufficient information for the Parties to determine whether the traffic terminated to those specific numbers within an NPA/NXX is Local Traffic, ISP-bound Traffic, IntraLATA Toll Traffic, Transit Traffic or Virtual NXX traffic. Any Virtual NXX billing disputes will be resolved through billing dispute procedures as set forth in the Agreement.
- 6.2 Percent Local Use. Each Party will report to the other a Percentage Local Usage ("PLU") factor for the reporting Party's originating traffic. The PLU will be utilized by the terminating Party to determine the amount of Local Traffic and ISP-bound Traffic minutes to be billed to the originating Party. For purposes of developing the PLU, the originating Party shall consider all Local Traffic, ISP-bound Traffic, IntraLATA Toll Traffic and Switched Access Traffic. By the first of January, April, July and October of each year, each Party shall provide a positive report updating the PLU. Requirements associated with PLU calculation and reporting shall be as set forth in BellSouth's Jurisdictional Factors Reporting Guidebook, as it is amended from time to time. Notwithstanding the foregoing, where the terminating Party has message recording technology that identifies the jurisdiction of traffic terminated as defined in this Agreement, such information, in lieu of the PLU factor, shall at the terminating Party's sole discretion be utilized to determine the appropriate Local Traffic and ISP-bound Traffic usage compensation to be paid. Use of such messaging recording technology shall not relieve either Party of its obligation to provide a PLU factor as set forth in this Section. The audit provisions of Section 6.5 apply whether Local Traffic and ISP-bound Traffic minutes billed to the originating Party are determined through use of the PLU or message recording technology.

The addresses for the receipt of PLU reports are:

Adelphia Business Solutions
ATTN: CABS Manager
721 N. Main Street
Coudersport, PA 16915

BellSouth
BellSouth Billing Manager
2300 North Lake Centre
Suite 415
Tucker, Georgia 30084

6.2.1 **Percent Local Facility.** Each Party shall report to the other a Percent Local Facility (“PLF”) factor. The application of the PLF will determine the portion of switched dedicated transport to be billed per the local jurisdiction rates. For purposes of developing the PLF, each Party shall consider every local and ISP-bound call and every long distance call. The PLF shall be applied to Multiplexing, Local Channel and Interoffice Channel Switched Dedicated Transport utilized in the provision of local interconnection trunks. Each Party shall update its PLF on the first of January, April, July and October of the year and shall send it to the other Party to be received no later than 30 days after the first of each such month to be effective the first bill period the following month, respectively. Requirements associated with PLU and PLF calculation and reporting shall be as set forth in BellSouth’s Jurisdictional Factors Reporting Guide, as it is amended from time to time.

11. The Parties hereby mutually agree to delete Section 6.7.1 to Attachment 3 of the Interconnection Agreement and replace with Section 6.7.1 incorporated herein as follows:

6.7.1 IntraLATA Toll Traffic. IntraLATA Toll Traffic is defined as any telephone call that is not Local Traffic or ISP-bound Traffic as defined in Section 6.1.3, or Switched Access Traffic per this Agreement.

12. The Parties hereby mutually agree to delete Section 6.7.4 to Attachment 3 of the Interconnection Agreement and replace with Section 6.7.4 incorporated herein as follows:

6.7.4 Records for 8XX Billing. Each Party will provide to the other the appropriate records necessary for billing intraLATA 8XX customers. The records provided will be in a standard EMI format.

13. The Parties hereby mutually agree to delete Sections 6.6 and 8 to Attachment 3 of the Interconnection Agreement in their entirety.

14. The Parties hereby mutually agree to delete Sections 6.6 and 8 to Attachment 3 of the Interconnection Agreement in their entirety.

15. The Parties hereby mutually agree to delete Attachment 4 of the Interconnection Agreement in its entirety and replace with Attachment 4 attached hereto as Exhibit 1 and incorporated herein by this reference.

16. The Parties hereby mutually agree to delete in their entirety Exhibit G of Attachment 1, Exhibit D of Attachment 2, Exhibit A of Attachment 3, Exhibit A of Attachment 4 and Exhibit A of Attachment 7 and replace with Exhibit G of Attachment 1, Exhibit D of Attachment 2, Exhibit A of Attachment 3, Exhibit A of Attachment 4 and Exhibit A of Attachment 7 attached hereto as Exhibit 2 and incorporated herein by this reference.

17. All of the other provisions of the Agreement, dated August 21, 2000 as amended, shall remain in full force and effect.

18. Either or both of the Parties is authorized to submit this Amendment to the respective state regulatory authorities for approval subject to Section 252(e) of the Federal Telecommunications Act of 1996.

IN WITNESS WHEREOF, the Parties hereto have caused this Amendment to be executed by their respective duly authorized representatives on the date indicated below.

Adelphia Business Solutions of Kentucky, Inc. . BellSouth Telecommunications, Inc.

By (Signature on File)

By: (Signature on File)

Name: John B. Glicksman

Name: Elizabeth R. A. Shiroishi

Title: Vice President & General Counsel

Title: Assistant Director

Date: 12/20/02

e:12/31/02

Attachment 4

Physical Collocation

BELLSOUTH
PHYSICAL COLLOCATION

1. Scope of Attachment

- 1.1 The rates, terms, and conditions contained within this Attachment shall only apply when Adelphia is physically collocated as a sole occupant or as a Host within a Premises location pursuant to this Attachment. BellSouth Premises include BellSouth Central Offices and Serving Wire Centers (hereinafter "Premises"). This Attachment is applicable to Premises owned or leased by BellSouth. However, if the Premises occupied by BellSouth is leased by BellSouth from a third party, special considerations and intervals may apply in addition to the terms and conditions of this Attachment.
- 1.2 Right to Occupy. BellSouth shall offer to Adelphia collocation on rates, terms, and conditions that are just, reasonable, non-discriminatory and consistent with the rules of the Federal Communications Commission ("FCC"). Subject to the rates, terms and conditions of this Attachment where space is available and it is technically feasible, BellSouth will allow Adelphia to occupy that certain area designated by BellSouth within a BellSouth Premises, or on BellSouth property upon which the BellSouth Premises is located, of a size which is specified by Adelphia and agreed to by BellSouth (hereinafter "Collocation Space"). The necessary rates, terms and conditions for BellSouth locations other than BellSouth Premises shall be negotiated upon request for collocation at such location(s).
- 1.2.1 Neither BellSouth nor any of BellSouth's affiliates may reserve space for future use on more preferential terms than those set forth below.
- 1.2.1.1 In Kentucky, the size specified by Adelphia may contemplate a request for space sufficient to accommodate Adelphia's growth within a two-year period.
- 1.3 Space Allocation. BellSouth shall attempt to accommodate Adelphia's requested preferences if any. In allocating Collocation Space, BellSouth shall not materially increase Adelphia's cost or materially delay Adelphia's occupation and use of the Collocation Space, shall not assign Collocation Space that will impair the quality of service or otherwise limit the service Adelphia wishes to offer, and shall not reduce unreasonably the total space available for physical collocation or preclude unreasonably physical collocation within the Premises. Space shall not be available for collocation if it is: (a) physically occupied by non-obsolete equipment; (b) assigned to another collocator; (c) used to provide physical access to occupied space; (d) used to enable technicians to work on equipment located within occupied space; (e) properly reserved for future use, either by BellSouth or by another carrier; or (f) essential for the administration and proper functioning of BellSouth's Premises. BellSouth may segregate Collocation Space and require separate entrances in accordance with FCC rules.

1.4 Space Reclamation. In the event of space exhaust within a Central Office Premises, BellSouth may include in its documentation for the Petition for Waiver filing any unutilized space in the Central Office Premises. Adelphia will be responsible for any justification of unutilized space within its space, if the Commission requires such justification.

1.5 Use of Space. Adelphia shall use the Collocation Space for the purposes of installing, maintaining and operating Adelphia's equipment (to include testing and monitoring equipment) necessary for interconnection with BellSouth services and facilities or for accessing BellSouth unbundled network elements for the provision of telecommunications services, as specifically set forth in this Attachment. The Collocation Space may be used for no other purposes except as specifically described herein or in any amendment hereto.

1.6 Rates and Charges. Adelphia agrees to pay the rates and charges identified in Exhibit B attached hereto.

1.7 If any due date contained in this Attachment falls on a weekend or National holiday, then the due date will be the next business day thereafter. For intervals of ten (10) calendar days or less National holidays will be excluded.

1.8 The parties agree to comply with all applicable federal, state, county, local and administrative laws, rules, ordinances, regulations and codes in the performance of their obligations hereunder.

2. Space Availability Report

2.1 Space Availability Report. Upon request from Adelphia, BellSouth will provide a written report ("Space Availability Report") describing in detail the space that is available for collocation and specifying the amount of Collocation Space available at the Premises requested, the number of collocators present at the Premises, any modifications in the use of the space since the last report on the Premises requested and the measures BellSouth is taking to make additional space available for collocation arrangements. A Space Availability Report does not reserve space at the Premises.

2.1.1 The request from Adelphia for a Space Availability Report must be written and must include the Premises street address, as identified in the Local Exchange Routing Guide ("LERG"), and Common Language Location Identification ("CLLI") code of the Premises. CLLI code information is located in the National Exchange Carriers Association ("NECA") Tariff FCC No. 4.

2.1.2 BellSouth will respond to a request for a Space Availability Report for a particular Premises within ten (10) calendar days of receipt of such request. BellSouth will make best efforts to respond in ten (10) calendar days to such a request when the request includes from two (2) to five (5) Premises within the same state. The response time

for requests of more than five (5) Premises shall be negotiated between the Parties. If BellSouth cannot meet the ten (10) calendar day response time, BellSouth shall notify Adelphia and inform Adelphia of the time frame under which it can respond.

3. Collocation Options

- 3.1 Cageless. BellSouth shall allow Adelphia to collocate Adelphia's equipment and facilities without requiring the construction of a cage or similar structure. BellSouth shall allow Adelphia to have direct access to Adelphia's equipment and facilities. BellSouth shall make cageless collocation available in single bay increments. Except where Adelphia's equipment requires special technical considerations (e.g., special cable racking, isolated ground plane, etc.), BellSouth shall assign cageless Collocation Space in conventional equipment rack lineups where feasible. For equipment requiring special technical considerations, Adelphia must provide the equipment layout, including spatial dimensions for such equipment pursuant to generic requirements contained in Telcordia GR-63-Core, and shall be responsible for compliance with all special technical requirements associated with such equipment.
- 3.2 Caged. At Adelphia's expense, Adelphia may arrange with a Supplier certified by BellSouth ("Certified Supplier") to construct a collocation arrangement enclosure in accordance with BellSouth's guidelines and specifications prior to starting equipment installation. BellSouth will provide guidelines and specifications upon request. Where local building codes require enclosure specifications more stringent than BellSouth's standard enclosure specification, Adelphia and Adelphia's Certified Supplier must comply with the more stringent local building code requirements. Adelphia's Certified Supplier shall be responsible for filing and receiving any and all necessary permits and/or licenses for such construction. BellSouth shall cooperate with Adelphia and provide, at Adelphia's expense, the documentation, including existing building architectural drawings, enclosure drawings, and specifications required and necessary for Adelphia to obtain the zoning, permits and/or other licenses. Adelphia's Certified Supplier shall bill Adelphia directly for all work performed for Adelphia pursuant to this Attachment and BellSouth shall have no liability for nor responsibility to pay such charges imposed by Adelphia's Certified Supplier. Adelphia must provide the local BellSouth building contact with two Access Keys used to enter the locked enclosure. Except in case of emergency, BellSouth will not access Adelphia's locked enclosure prior to notifying Adelphia. Upon request, BellSouth shall construct the enclosure for Adelphia.
- 3.2.1 BellSouth may elect to review Adelphia's plans and specifications prior to allowing construction to start to ensure compliance with BellSouth's guidelines and specifications. Notification to Adelphia indicating BellSouth's desire to execute this review will be provided in BellSouth's response to the Initial Application, if Adelphia has indicated its desire to construct its own enclosure. If Adelphia's Initial Application does not indicate its desire to construct its own enclosure, but its subsequent firm order does indicate its desire to construct its own enclosure, then notification to

review will be given within ten (10) calendar days after the Firm Order date. BellSouth shall complete its review within fifteen (15) calendar days after the receipt of the plans and specifications. Regardless of whether or not BellSouth elects to review Adelphia's plans and specifications, BellSouth reserves the right to inspect the enclosure after construction to make sure it is constructed according to the submitted plans and specifications and/or BellSouth's guidelines and specifications, as applicable. If BellSouth decides to inspect, BellSouth will complete its inspection within fifteen (15) calendar days after receipt of written notification of completion of the enclosure from Adelphia. BellSouth shall require Adelphia to remove or correct within seven (7) calendar days at Adelphia's expense any structure that does not meet these plans and specifications or, where applicable, BellSouth guidelines and specifications.

- 3.3 Shared Caged Collocation. Adelphia may allow other telecommunications carriers to share Adelphia's caged collocation arrangement pursuant to terms and conditions agreed to by Adelphia ("Host") and other telecommunications carriers ("Guests") and pursuant to this Section, except where the BellSouth Premises is located within a leased space and BellSouth is prohibited by said lease from offering such an option. Adelphia shall notify BellSouth in writing upon execution of any agreement between the Host and its Guest within ten (10) calendar days of its execution and prior to any Firm Order. Further, such notice shall include the name of the Guest(s) and the term of the agreement, and shall contain a certification by Adelphia that said agreement imposes upon the Guest(s) the same terms and conditions for Collocation Space as set forth in this Attachment between BellSouth and Adelphia.
- 3.3.1 Adelphia, as the Host, shall be the sole interface and responsible Party to BellSouth for the assessment and billing of rates and charges contained within this Attachment and for the purposes of ensuring that the safety and security requirements of this Attachment are fully complied with by the Guest(s), its employees and agents. BellSouth shall provide Adelphia with a proration of the costs of the Collocation Space based on the number of collocators and the space used by each with a minimum charge of one (1) bay/rack per Host/Guest. In all states other than Florida, and in addition to the foregoing, Adelphia shall be the responsible party to BellSouth for the purpose of submitting applications for initial and additional equipment placement of the Guest. A separate Guest application shall require the assessment of an Initial or Subsequent Application Fee, as set forth in Exhibit B, which will be billed to the Host on the date that BellSouth provides its written response ("Application Response").
- 3.3.2 Notwithstanding the foregoing, the Guest may arrange directly with BellSouth for the provision of the interconnecting facilities between BellSouth and the Guest and for the provision of the services and access to unbundled network elements. The bill for these interconnecting facilities, services and access to UNEs will be charged to the Guest pursuant to the applicable tariff or the Guest's Interconnection Agreement with BellSouth.

- 3.3.3 Adelphia shall indemnify and hold harmless BellSouth from any and all claims, actions, causes of action, of whatever kind or nature arising out of the presence of Adelphia's Guests in the Collocation Space except to the extent caused by BellSouth's sole negligence, gross negligence, or willful misconduct.
- 3.4 Adjacent Collocation. Subject to technical feasibility and space availability, BellSouth will permit adjacent collocation arrangements ("Adjacent Arrangement") on the Premises' property, where the Adjacent Arrangement does not interfere with access to existing or planned structures or facilities on the Premises property. The Adjacent Arrangement shall be constructed or procured by Adelphia and in conformance with BellSouth's design and construction specifications. Further, Adelphia shall construct, procure, maintain and operate said Adjacent Arrangement(s) pursuant to all of the rates, terms and conditions set forth in this Attachment.
- 3.4.1 Should Adelphia elect Adjacent Collocation, Adelphia must arrange with a Certified Supplier to construct an Adjacent Arrangement structure in accordance with BellSouth's guidelines and specifications. BellSouth will provide guidelines and specifications upon request. Where local building codes require enclosure specifications more stringent than BellSouth's standard specification, Adelphia and Adelphia's Certified Supplier must comply with the more stringent local building code requirements. Adelphia's Certified Supplier shall be responsible for filing and receiving any and all necessary zoning, permits and/or licenses for such construction. Adelphia's Certified Supplier shall bill Adelphia directly for all work performed for Adelphia pursuant to this Attachment and BellSouth shall have no liability for nor responsibility to pay such charges imposed by Adelphia's Certified Supplier. Adelphia must provide the local BellSouth building contact with two cards, keys or other access device used to enter the locked enclosure. Except in cases of emergency, BellSouth shall not access Adelphia's locked enclosure prior to notifying Adelphia.
- 3.4.2 Adelphia must submit its plans and specifications to BellSouth with its Firm Order. BellSouth shall review Adelphia's plans and specifications prior to construction of an Adjacent Arrangement(s) to ensure compliance with BellSouth's guidelines and specifications. BellSouth shall complete its review within fifteen (15) calendar days after receipt of plans and specifications. BellSouth may inspect the Adjacent Arrangement during and after construction to confirm it is constructed according to the submitted plans and specifications. If BellSouth decides to inspect, BellSouth will complete its inspection within fifteen (15) calendar days after receipt of written notification of completion of the enclosure from Adelphia. BellSouth shall require Adelphia to remove or correct within seven (7) calendar days at Adelphia's expense any structure that does not meet these plans and specifications or, where applicable, BellSouth's guidelines and specifications.
- 3.4.3 Adelphia shall provide a concrete pad, the structure housing the arrangement, heating/ventilation/air conditioning ("HVAC"), lighting, and all facilities that connect the structure (i.e. racking, conduits, etc.) to the BellSouth point of demarcation. At Adelphia's option, and where the local authority having jurisdiction permits, BellSouth

shall provide an AC power source and access to physical collocation services and facilities subject to the same nondiscriminatory requirements as applicable to any other physical collocation arrangement.

- 3.5 Co-Carrier Cross Connect (CCXC). The primary purpose of collocation is for a collocated telecommunications carrier to interconnect with BellSouth's network or to access BellSouth's unbundled network elements for the provision of telecommunications services within a BellSouth Premises. BellSouth will permit Adelphia to interconnect between its virtual or physical collocation arrangements and those of another collocated telecommunications carrier within the same central office. Both Adelphia's agreement and the other collocated telecommunications carrier's agreement must contain rates, terms and conditions for CCXC language. At no point in time shall Adelphia use the Collocation Space for the sole or primary purpose of cross connecting to other collocated telecommunications carriers.
- 3.5.1 Adelphia must use a BellSouth Certified Supplier to place the CCXC. The CCXC shall be provisioned through facilities owned by Adelphia. Such connections to other carriers may be made using either optical or electrical facilities. In cases where Adelphia's equipment and the equipment of the other interconnector are located in contiguous caged Collocation Spaces, Adelphia will have the option of using Adelphia's own technicians to deploy co-carrier cross connects using either electrical or optical facilities between the sets of equipment and construct its own dedicated cable support structure. Adelphia may deploy such optical or electrical connections directly between its own facilities and the facilities of other collocated telecommunications carriers without being routed through BellSouth equipment. Adelphia may not self-provision CCXC on any BellSouth distribution frame, POT (Point of Termination) Bay, DSX (Digital System Cross-connect) or LGX (Light Guide Cross-connect). Adelphia is responsible for ensuring the integrity of the signal.
- 3.5.2 Adelphia shall be responsible for providing written authorization to BellSouth from the other collocated telecommunications carrier prior to installing the CCXC. Adelphia-provisioned CCXC shall utilize common cable support structure. There will be a recurring charge per linear foot, per cable, of common cable support structure used. In the case of two contiguous caged collocation arrangements, Adelphia will have the option of using Adelphia's own technicians to construct its own dedicated support structure.
- 3.5.3 To order CCXCs Adelphia must submit an Initial Application or Subsequent Application. If no modification to the Collocation Space is requested other than the placement of CCXCs, the Subsequent Application Fee for CCXC, as defined in Exhibit B, will apply. If modifications in addition to the placement of CCXCs are requested, the Initial Application or Subsequent Application Fee will apply. This non-recurring fee will be billed by BellSouth on the date that BellSouth provides an Application Response.

4. Occupancy

- 4.1 Occupancy. BellSouth will notify Adelphia in writing that the Collocation Space is ready for occupancy ("Space Ready Date"). Adelphia will schedule and complete an acceptance walk-through of each Collocation Space with BellSouth within fifteen (15) calendar days of BellSouth's notifying Adelphia that the Collocation Space is ready for occupancy. BellSouth will correct any deviations to Adelphia's original or jointly amended requirements within seven (7) calendar days after the walk-through, unless the Parties jointly agree upon a different time frame, and BellSouth shall establish a new Space Ready Date. Another acceptance walk-through will then be scheduled and conducted within fifteen (15) calendar days of the new Space Ready Date. This follow-up acceptance walk-through will be limited to those items identified in the initial walk-through. If Adelphia has met the fifteen (15) calendar day interval(s), billing will begin upon the date of Adelphia's acceptance of the Collocation Space ("Space Acceptance Date"). In the event that Adelphia fails to complete an acceptance walk-through within this fifteen (15) calendar day interval, the Collocation Space shall be deemed accepted by Adelphia. Billing will commence on the Space Ready Date or on the Space Acceptance Date, whichever is sooner. Adelphia must notify BellSouth in writing that collocation equipment installation is complete and is operational with BellSouth's network. BellSouth may, at its option, not accept orders for cross connects until receipt of such notice. For purposes of this paragraph, Adelphia's telecommunications equipment will be deemed operational when cross-connected to BellSouth's network for the purpose of service provisioning.
- 4.2 Termination of Occupancy. In addition to any other provisions addressing termination of occupancy in this Agreement, Adelphia may terminate occupancy in a particular Collocation Space by submitting a Subsequent Application requesting termination of occupancy. A Subsequent Application Fee will not apply for termination of occupancy. BellSouth may terminate Adelphia's right to occupy the Collocation Space in the event Adelphia fails to comply with any provision of this Agreement including the payment of applicable fees.

Upon termination of occupancy, Adelphia at its expense shall remove its equipment and other property from the Collocation Space. Adelphia shall have thirty (30) calendar days from the termination date to complete such removal, including the removal of all equipment and facilities of Adelphia's Guests, unless Adelphia's Guest has assumed responsibility for the Collocation Space housing the Guest's equipment and executed the documentation required by BellSouth prior to such removal date. Adelphia shall continue payment of monthly fees to BellSouth until such date as Adelphia, and if applicable Adelphia's Guest, has fully vacated the Collocation Space and the Space Relinquish Form has been accepted by BellSouth. Should Adelphia or Adelphia's Guest fail to vacate the Collocation Space within thirty (30) calendar days from the termination date, BellSouth shall have the right to remove the equipment and dispose of the equipment and other property of Adelphia or Adelphia's Guest(s), in any manner that BellSouth deems fit, at Adelphia's expense and with no liability whatsoever for Adelphia's property or Adelphia's Guest(s)'s property. Upon

termination of Adelphia's right to occupy Collocation Space, the Collocation Space will revert back to BellSouth, and Adelphia shall surrender such Collocation Space to BellSouth in the same condition as when first occupied by Adelphia except for ordinary wear and tear, unless otherwise agreed to by the Parties. Adelphia's BellSouth Certified Supplier shall be responsible for updating and making any necessary changes to BellSouth's records as required by BellSouth's guidelines and specifications including but not limited to Central Office Record Drawings and ERMA Records. Adelphia shall be responsible for the cost of removing any Adelphia constructed enclosure, together with all support structures (e.g., racking, conduits, power cables, etc.), at the termination of occupancy and restoring the grounds to their original condition.

5. Use of Collocation Space

- 5.1 Equipment Type. BellSouth permits the collocation of any type of equipment necessary for interconnection to BellSouth's network or for access to BellSouth's unbundled network elements in the provision of telecommunications services, as the term "necessary" is defined by FCC 47 C.F.R. Section 51.323 (b). The primary purpose and function of any equipment collocated in a Premises must be for interconnection to BellSouth's network or for access to BellSouth's unbundled network elements in the provision of telecommunications services.
- 5.1.1 Examples of equipment that would not be considered necessary include but are not limited to: Traditional circuit switching equipment, equipment used exclusively for call-related databases, computer servers used exclusively for providing information services, operations support system (OSS) equipment used to support collocated telecommunications carrier network operations, equipment that generates customer orders, manages trouble tickets or inventory, or stores customer records in centralized databases, etc. BellSouth will determine upon receipt of an application if the requested equipment is necessary based on the criteria established by the FCC. Multifunctional equipment placed on BellSouth's Premises must not place any greater relative burden on BellSouth's property than comparable single-function equipment. BellSouth reserves the right to permit collocation of any equipment on a nondiscriminatory basis.
- 5.1.2 Such equipment must, at a minimum, meet the following Telcordia Network Equipment Building Systems (NEBS) General Equipment Requirements: Criteria Level 1 requirements as outlined in the Telcordia Special Report SR-3580, Issue 1; equipment design spatial requirements per GR-63-CORE, Section 2; thermal heat dissipation per GR-063-CORE, Section 4, Criteria 77-79; acoustic noise per GR-063-CORE, Section 4, Criterion 128, and National Electric Code standards. Except where otherwise required by a Commission, BellSouth shall comply with the applicable FCC rules relating to denial of collocation based on Adelphia's failure to comply with this Section.

- 5.1.3 Adelphia shall not request more DS0, DS1, DS3 and optical terminations for a collocation arrangement than the total port or termination capacity of the equipment physically installed in the arrangement. The total capacity of the equipment collocated in the arrangement will include equipment contained in the application in question as well as equipment already placed in the arrangement. If full network termination capacity of the equipment being installed is not requested in the application, additional network terminations for the installed equipment will require the submission of another application. In the event that Adelphia submits an application for terminations that exceed the total capacity of the collocated equipment, Adelphia will be informed of the discrepancy and will be required to submit a revision to the application.
- 5.2 Adelphia shall identify to BellSouth whenever Adelphia submits a Method of Procedure (“MOP”) adding equipment to Adelphia’s Collocation Space all UCC-1 lien holders or other entities that have a financial interest, secured and otherwise, in the equipment in Adelphia’s Collocation Space.
- 5.3 Adelphia shall not use the Collocation Space for marketing purposes nor shall it place any identifying signs or markings outside the Collocation Space or on the grounds of the Premises.
- 5.4 Adelphia shall place a plaque or other identification affixed to Adelphia’s equipment necessary to identify Adelphia’s equipment, including a list of emergency contacts with telephone numbers.
- 5.5 Entrance Facilities. Adelphia may elect to place Adelphia-owned or Adelphia-leased fiber entrance facilities into the Collocation Space. BellSouth will designate the point of interconnection in close proximity to the Premises building housing the Collocation Space, such as an entrance manhole or a cable vault, which are physically accessible by both Parties. Adelphia will provide and place fiber cable at the point of entrance of sufficient length to be pulled through conduit and into the splice location. Adelphia will provide and install a sufficient length of fire retardant riser cable, to which the entrance cable will be spliced by BellSouth, which will extend from the splice location to Adelphia’s equipment in the Collocation Space. In the event Adelphia utilizes a non-metallic, riser-type entrance facility, a splice will not be required. Adelphia must contact BellSouth for instructions prior to placing the entrance facility cable in the manhole. Adelphia is responsible for maintenance of the entrance facilities. At Adelphia’s option BellSouth will accommodate where technically feasible a microwave entrance facility pursuant to separately negotiated terms and conditions. In the case of adjacent collocation, unless BellSouth determines that limited space is available for the entrance facilities, copper facilities may be used between the adjacent collocation arrangement and the central office demarcation point.
- 5.5.1 Dual Entrance. BellSouth will provide at least two interconnection points at each Premises where there are at least two such interconnection points available and where capacity exists. Upon receipt of a request for physical collocation under this

- Attachment, BellSouth shall provide Adelphia with information regarding BellSouth's capacity to accommodate dual entrance facilities. If conduit in the serving manhole(s) is available and is not reserved for another purpose for utilization within 12 months of the receipt of an application for collocation, BellSouth will make the requested conduit space available for installing a second entrance facility to Adelphia's arrangement. The location of the serving manhole(s) will be determined at the sole discretion of BellSouth. Where dual entrance is not available due to lack of capacity, BellSouth will so state in the Application Response.
- 5.5.2 Shared Use. Adelphia may utilize spare capacity on an existing interconnector entrance facility for the purpose of providing an entrance facility to Adelphia's collocation arrangement within the same BellSouth Premises. BellSouth shall allow the splice, provided that the fiber is non-working fiber. Adelphia must arrange with BellSouth for BellSouth to splice the Adelphia provided riser cable to the spare capacity on the entrance facility. The rates set forth in Exhibit B will apply. If Adelphia desires to allow another telecommunications carrier to use its entrance facilities, additional rates, terms and conditions will apply and shall be negotiated between the Parties.
- 5.6 Demarcation Point. BellSouth will designate the point(s) of demarcation between Adelphia's equipment and/or network and BellSouth's network. Each Party will be responsible for maintenance and operation of all equipment/facilities on its side of the demarcation point. For 2-wire and 4-wire connections to BellSouth's network, the demarcation point shall be a common block on the BellSouth designated conventional distributing frame (CDF). Adelphia shall be responsible for providing, and a supplier certified by BellSouth ("BellSouth Certified Supplier") shall be responsible for installing and properly labeling/stenciling the common block and necessary cabling pursuant to Section 7. For all other terminations BellSouth shall designate a demarcation point on a per arrangement basis. Adelphia or its agent must perform all required maintenance to equipment/facilities on its side of the demarcation point, pursuant to Section 5.7, following, and may self-provision cross-connects that may be required within the Collocation Space to activate service requests.
- 5.7 Adelphia's Equipment and Facilities. Adelphia, or if required by this Attachment, Adelphia's BellSouth Certified Supplier, is solely responsible for the design, engineering, installation, testing, provisioning, performance, monitoring, maintenance and repair of the equipment and facilities used by Adelphia which must be performed in compliance with all applicable BellSouth policies and guidelines. Such equipment and facilities may include but are not limited to cable(s), equipment, and point of termination connections. Adelphia and its selected BellSouth Certified Supplier must follow and comply with all BellSouth requirements outlined in BellSouth's TR 73503, TR 73519, TR 73572, and TR 73564.
- 5.8 BellSouth's Access to Collocation Space. From time to time BellSouth may require access to the Collocation Space. BellSouth retains the right to access such space for

- the purpose of making BellSouth equipment and building modifications (e.g., running, altering or removing racking, ducts, electrical wiring, HVAC, and cables). BellSouth will give notice to Adelphia at least forty-eight (48) hours before access to the Collocation Space is required. Adelphia may elect to be present whenever BellSouth performs work in the Collocation Space. The Parties agree that Adelphia will not bear any of the expense associated with this work.
- 5.9 Access. Pursuant to Section 12, Adelphia shall have access to the Collocation Space twenty-four (24) hours a day, seven (7) days a week. Adelphia agrees to provide the name and social security number or date of birth or driver's license number of each employee, supplier, or agent of Adelphia or Adelphia's Guests provided with access keys or devices ("Access Keys") prior to the issuance of said Access Keys. Key acknowledgement forms must be signed by Adelphia and returned to BellSouth Access Management within fifteen (15) calendar days of Adelphia's receipt. Failure to return properly acknowledged forms will result in the holding of subsequent requests until acknowledgements are current. Access Keys shall not be duplicated under any circumstances. Adelphia agrees to be responsible for all Access Keys and for the return of all said Access Keys in the possession of Adelphia's employees, suppliers, Guests, or agents after termination of the employment relationship, contractual obligation with Adelphia or upon the termination of this Attachment or the termination of occupancy of an individual collocation arrangement.
- 5.9.1 BellSouth will permit one accompanied site visit to Adelphia's designated collocation arrangement location after receipt of the Bona Fide Firm Order (BFFO) without charge to Adelphia. Adelphia must submit to BellSouth the completed Access Control Request Form for all employees or agents requiring access to the BellSouth Premises a minimum of thirty (30) calendar days prior to the date Adelphia desires access to the Collocation Space. In order to permit reasonable access during construction of the Collocation Space, Adelphia may submit such a request at any time subsequent to BellSouth's receipt of the BFFO. In the event Adelphia desires access to the Collocation Space after submitting such a request but prior to access being approved, in addition to the first accompanied free visit, BellSouth shall permit Adelphia to access the Collocation Space accompanied by a security escort at Adelphia's expense. Adelphia must request escorted access at least three (3) business days prior to the date such access is desired.
- 5.10 Lost or Stolen Access Keys. Adelphia shall notify BellSouth in writing immediately in the case of lost or stolen Access Keys. Should it become necessary for BellSouth to re-key buildings or deactivate a card as a result of a lost Access Key(s) or for failure to return an Access Key(s), Adelphia shall pay for all reasonable costs associated with the re-keying or deactivating the card.
- 5.11 Interference or Impairment. Notwithstanding any other provisions of this Attachment, Adelphia shall not use any product or service provided under this Agreement, any other service related thereto or used in combination therewith, or place or use any equipment or facilities in any manner that 1) significantly degrades, interferes with or

- impairs service provided by BellSouth or by any other entity or any person's use of its telecommunications service; 2) endangers or damages the equipment, facilities or other property of BellSouth or of any other entity or person; 3) compromises the privacy of any communications; or 4) creates an unreasonable risk of injury or death to any individual or to the public. If BellSouth reasonably determines that any equipment or facilities of Adelphia violates the provisions of this paragraph, BellSouth shall give written notice to Adelphia, which notice shall direct Adelphia to cure the violation within forty-eight (48) hours of Adelphia's actual receipt of written notice or, at a minimum, to commence curative measures within twenty-four (24) hours and to exercise reasonable diligence to complete such measures as soon as possible thereafter. After receipt of the notice, the Parties agree to consult immediately and, if necessary, to inspect the arrangement.
- 5.11.1 Except in the case of the deployment of an advanced service which significantly degrades the performance of other advanced services or traditional voice band services, if Adelphia fails to take curative action within forty-eight (48) hours or if the violation is of a character which poses an immediate and substantial threat of damage to property, injury or death to any person, or any other significant degradation, interference or impairment of BellSouth's or another entity's service, then and only in that event BellSouth may take such action as it deems appropriate to correct the violation, including without limitation the interruption of electrical power to Adelphia's equipment. BellSouth will endeavor, but is not required, to provide notice to Adelphia prior to taking such action and shall have no liability to Adelphia for any damages arising from such action, except to the extent that such action by BellSouth constitutes willful misconduct.
- 5.11.2 For purposes of this Section, the term significantly degrade shall mean an action that noticeably impairs a service from a user's perspective. In the case of the deployment of an advanced service which significantly degrades the performance of other advanced services or traditional voice band services and Adelphia fails to take curative action within forty-eight (48) hours then BellSouth will establish before the Commission that the technology deployment is causing the significant degradation. Any claims of network harm presented to Adelphia or, if subsequently necessary, the Commission must be supported with specific and verifiable information. Where BellSouth demonstrates that a deployed technology is significantly degrading the performance of other advanced services or traditional voice band services, Adelphia shall discontinue deployment of that technology and migrate its customers to technologies that will not significantly degrade the performance of other such services. Where the only degraded service itself is a known disturber, and the newly deployed technology satisfies at least one of the criteria for a presumption that is acceptable for deployment under Section 47 C.F.R. 51.230, the degraded service shall not prevail against the newly deployed technology.
- 5.12 Personalty and its Removal. Facilities and equipment placed by Adelphia in the Collocation Space shall not become a part of the Collocation Space, even if nailed, screwed or otherwise fastened to the Collocation Space, but shall retain their status as

- personal property and may be removed by Adelphia at any time. Any damage caused to the Collocation Space by Adelphia's employees, agents or representatives during the removal of such property shall be promptly repaired by Adelphia at its expense.
- 5.12.1 If Adelphia decides to remove equipment from its Collocation Space and the removal requires no physical changes, BellSouth will bill Adelphia an Administrative Only Application Fee as set forth in Exhibit B for these changes. This non-recurring fee will be billed on the date that BellSouth provides an Application Response.
- 5.13 Alterations. In no case shall Adelphia or any person acting on behalf of Adelphia make any rearrangement, modification, improvement, addition, or other alteration which could affect in any way space, power, HVAC, and/or safety considerations to the Collocation Space or the BellSouth Premises without the written consent of BellSouth, which consent shall not be unreasonably withheld. The cost of any such specialized alterations shall be paid by Adelphia. Any such material rearrangement, modification, improvement, addition, or other alteration shall require a Subsequent Application and Subsequent Application Fee, which will be billed by BellSouth on the date that BellSouth makes an Application Response.
- 5.14 Janitorial Service. Adelphia shall be responsible for the general upkeep of the Collocation Space. Adelphia shall arrange directly with a BellSouth Certified Supplier for janitorial services applicable to Caged Collocation Space. BellSouth shall provide a list of such suppliers on a site-specific basis upon request.
- 6. Ordering and Preparation of Collocation Space**
- 6.1 Should any state or federal regulatory agency impose procedures or intervals applicable to Adelphia and BellSouth that are different from procedures or intervals set forth in this Section, whether now in effect or that become effective after execution of this Agreement, those procedures or intervals shall supersede the requirements set forth herein for that jurisdiction for all applications submitted for the first time after the effective date thereof.
- 6.2 Initial Application. For Adelphia or Adelphia's Guest(s) initial equipment placement, Adelphia shall submit to BellSouth a Physical Expanded Interconnection Application Document ("Initial Application"). The Initial Application is Bona Fide when it is complete and accurate, meaning that all required fields on the application are completed with the appropriate type of information. An application fee will apply which will be billed by BellSouth on the date that BellSouth makes an Application Response.
- 6.3 Subsequent Application. In the event Adelphia or Adelphia's Guest(s) desires to modify the use of the Collocation Space after a BFFO, Adelphia shall complete an application detailing all information regarding the modification to the Collocation Space ("Subsequent Application"). The Subsequent Application is Bona Fide when it is complete and accurate, meaning that all required fields on the Subsequent

Application are completed with the appropriate type of information. BellSouth shall determine what modifications, if any, to the Premises are required to accommodate the change requested by Adelphia in the application. Such necessary modifications to the Premises may include, but are not limited to, floor loading changes, changes necessary to meet HVAC requirements, changes to power plant requirements, equipment additions, etc.

- 6.3.1 Subsequent Application Fee. The application fee paid by Adelphia for its request to modify the use of the Collocation Space shall be dependent upon the level of assessment needed for the modification requested. The fee for a Subsequent Application where the modification requested has limited effect (e.g., requires labor expenditure but no capital expenditure by BellSouth and where sufficient cable support structure, HVAC, power and terminations are available) shall be the Subsequent Application Fee as set forth in Exhibit B. If the modification requires capital expenditure, an Initial Application Fee shall apply. This non-recurring fee will be billed on the date that BellSouth makes an Application Response.
- 6.4 Space Preferences. If Adelphia has previously requested and received a Space Availability Report for the Premises, Adelphia may submit up to three (3) space preferences on its application identifying specific space identification numbers as referenced on the Space Availability Report. In the event that BellSouth can-not accommodate the Adelphia's preference(s), Adelphia may elect to accept the space allocated by BellSouth or may cancel its application and submit another application requesting additional preferences, which will be treated as a new application and an application fee will apply which will be billed by BellSouth on the date that BellSouth makes an Application Response.
- 6.5 Space Availability Notification.
- 6.5.1 Unless otherwise specified, BellSouth will respond to an application within ten (10) calendar days as to whether space is available or not available within a BellSouth Premises. BellSouth will also respond as to whether the application is Bona Fide and if it is not Bona Fide, the items necessary to cause the application to become Bona Fide. If the amount of space requested is not available, BellSouth will notify Adelphia of the amount of space that is available and no application fee shall apply. When BellSouth's response includes an amount of space less than that requested by Adelphia or differently configured, Adelphia must resubmit its application to reflect the actual space available.
- 6.6 Denial of Application. If BellSouth notifies Adelphia that no space is available ("Denial of Application"), BellSouth will not assess an Application Fee. After notifying Adelphia that BellSouth has no available space in the requested Premises, BellSouth will allow Adelphia, upon request, to tour the entire Premises within ten (10) calendar days of such Denial of Application. In order to schedule said tour within

- ten (10) calendar days, the request for a tour of the Premises must be received by BellSouth within five (5) calendar days of the Denial of Application.
- 6.7 Filing of Petition for Waiver. Upon Denial of Application, BellSouth will timely file a petition with the Commission pursuant to 47 U.S.C. § 251(c)(6). BellSouth shall provide to the Commission any information requested by that Commission. Such information shall include which space, if any, BellSouth or any of BellSouth's affiliates have reserved for future use and a detailed description of the specific future uses for which the space has been reserved. Subject to an appropriate nondisclosure agreement or provision, BellSouth shall permit Adelphia to inspect any floor plans or diagrams that BellSouth provides to the Commission.
- 6.8 Waiting List. On a first-come, first-served basis governed by the date of receipt of an application or Letter of Intent, BellSouth will maintain a waiting list of requesting carriers who have either received a Denial of Application or, where it is publicly known that the Premises is out of space, have submitted a Letter of Intent to collocate. BellSouth will notify the telecommunications carriers on the waiting list that can be accommodated by the amount of space that becomes available according to the position of the telecommunications carriers on said waiting list.
- 6.8.1 When space becomes available, Adelphia must submit an updated, complete, and correct application to BellSouth within thirty (30) calendar days of such notification. If Adelphia has originally requested caged Collocation Space and cageless Collocation Space becomes available, Adelphia may refuse such space and notify BellSouth in writing within that time that Adelphia wants to maintain its place on the waiting list without accepting such space. Adelphia may accept an amount of space less than its original request by submitting an application as set forth above, and upon request, may maintain its position on the waiting list for the remaining space that was initially requested. If Adelphia does not submit such an application or notify BellSouth in writing as described above, BellSouth will offer such space to the next telecommunications carrier on the waiting list and remove Adelphia from the waiting list. Upon request, BellSouth will advise Adelphia as to its position on the list.
- 6.9 Public Notification. BellSouth will maintain on its Interconnection Services website a notification document that will indicate all Central Offices that are without available space. BellSouth shall update such document within ten (10) calendar days of the date BellSouth becomes aware that there is insufficient space to accommodate physical collocation. BellSouth will also post a document on its Interconnection Services website that contains a general notice where space has become available in a Central Office previously on the space exhaust list.
- 6.10 Application Response.

6.10.1 In Kentucky, when space has been determined to be available for caged or cageless arrangements, BellSouth will provide an Application Response within twenty (20) calendar days of receipt of a Bona Fide application. The Application Response will include, at a minimum, the configuration of the space, the Cable Installation Fee, Cable Records Fee, and any other applicable space preparation fees, as described in Section 8.

6.11 Application Modifications.

6.11.1 If a modification or revision is made to any information in the Bona Fide application prior to a BFFO, with the exception of modifications to Customer Information, Contact Information or Billing Contact Information, either at the request of Adelphia or necessitated by technical considerations, said application shall be considered a new application and shall be handled as a new application with respect to response and provisioning intervals and BellSouth may charge Adelphia an additional application fee. The fee for an application modification where the modification requested has limited effect (e.g., requires labor expenditure but no capital expenditure by BellSouth and where sufficient cable support structure, HVAC, power and terminations are available) shall be the Subsequent Application Fee as set forth in Exhibit B. A modification involving a capital expenditure by BellSouth shall require Adelphia to submit the application with an Initial Application Fee. This non-recurring fee will be billed by BellSouth on the date that BellSouth provides an Application Response.

6.12 Bona Fide Firm Order.

6.12.1 Adelphia shall indicate its intent to proceed with equipment installation in a BellSouth Premises by submitting a Firm Order to BellSouth. The BFFO must be received by BellSouth no later than thirty (30) calendar days after BellSouth's Application Response to Adelphia's Bona Fide application or the application will expire.

6.12.2 BellSouth will establish a firm order date based upon the date BellSouth is in receipt of a BFFO. BellSouth will acknowledge the receipt of Adelphia's BFFO within seven (7) calendar days of receipt indicating that the BFFO has been received. A BellSouth response to a BFFO will include a Firm Order Confirmation containing the firm order date. No revisions will be made to a BFFO.

7. Construction and Provisioning

7.1 Construction and Provisioning Intervals

7.1.1 In Kentucky, BellSouth will complete construction for caged collocation arrangements under ordinary conditions as soon as possible and within a maximum of ninety (90) calendar days from receipt of a BFFO or as agreed to by the Parties. BellSouth will

- complete construction for cageless collocation arrangements under ordinary conditions as soon as possible and within a maximum of sixty (60) calendar days from receipt of a BFFO and ninety (90) calendar days from receipt of a BFFO for extraordinary conditions or as agreed to by the Parties. Ordinary conditions are defined as space available with only minor changes to support systems required, such as but not limited to, HVAC, cabling and the power plant(s). Extraordinary conditions are defined to include but are not limited to major BellSouth equipment rearrangement or addition; power plant addition or upgrade; major mechanical addition or upgrade; major upgrade for ADA compliance; environmental hazard or hazardous materials abatement; and arrangements for which equipment shipping intervals are extraordinary in length. The Parties may mutually agree to renegotiate an alternative provisioning interval or BellSouth may seek a waiver from this interval from the Commission.
- 7.2 Joint Planning. Joint planning between BellSouth and Adelphia will commence within a maximum of twenty (20) calendar days from BellSouth's receipt of a BFFO. BellSouth will provide the preliminary design of the Collocation Space and the equipment configuration requirements as reflected in the Bona Fide application and affirmed in the BFFO. The Collocation Space completion time period will be provided to Adelphia during joint planning.
- 7.3 Permits. Each Party or its agents will diligently pursue filing for the permits required for the scope of work to be performed by that Party or its agents within ten (10) calendar days of the completion of finalized construction designs and specifications.
- 7.4 Acceptance Walk-through. Adelphia will schedule and complete an acceptance walk-through of each Collocation Space with BellSouth within fifteen (15) calendar days of BellSouth's notifying Adelphia that the Collocation Space is ready for occupancy (Space Ready Date). In the event that Adelphia fails to complete an acceptance walk-through within this fifteen (15) day interval, the Collocation Space shall be deemed accepted by Adelphia. BellSouth will correct any deviations to Adelphia's original or jointly amended requirements within seven (7) calendar days after the walk-through, unless the Parties jointly agree upon a different time frame.
- 7.5 Circuit Facility Assignments (CFAs). Unless otherwise specified, BellSouth will provide CFAs to Adelphia prior to the applicable provisioning interval set forth herein ("Provisioning Interval") for those Premises in which Adelphia has a physical collocation arrangement with no POT bay or with a POT bay provided by BellSouth prior to 6/1/99. BellSouth cannot provide CFAs to Adelphia prior to the Provisioning Interval for those Premises in which Adelphia has a physical collocation arrangement with a POT bay provided by Adelphia prior to 6/1/99 or a virtual collocation arrangement until Adelphia provides BellSouth with the following information:

For Adelphia-provided POT bay - a complete layout of the POT panels (equipment inventory update (EIU) form) showing locations, speeds, etc.

For virtual - a complete layout of Adelphia's equipment (equipment inventory update (EIU) form), including the locations of the low speed ports and the specific frame terminations to which the equipment will be wired by Adelphia's BellSouth Certified Supplier

BellSouth cannot begin work on the CFAs until the complete and accurate EIU form is received from Adelphia. If this EIU is provided ten (10) calendar days prior to the Provisioning Interval, then CFAs will be made available by the Provisioning Interval. If this EIU is not received ten (10) calendar days prior to the Provisioning Interval, then the CFAs will be provided within ten (10) calendar days of receipt of the EIU.

- 7.5.1 BellSouth will bill Adelphia a nonrecurring charge, as set forth in Exhibit B, each time Adelphia requests a resend of its CFAs for any reason other than a BellSouth error in the CFAs.
- 7.6 Use of BellSouth Certified Supplier. Adelphia shall select a supplier which has been approved as a BellSouth Certified Supplier to perform all engineering and installation work. Adelphia and Adelphia's BellSouth Certified Supplier must follow and comply with all BellSouth requirements outlined in BellSouth's TR 73503, TR 73519, TR 73572, and TR 73564. In some cases, Adelphia must select separate BellSouth Certified Suppliers for transmission equipment, switching equipment and power equipment. BellSouth shall provide Adelphia with a list of BellSouth Certified Suppliers upon request. The BellSouth Certified Supplier(s) shall be responsible for installing Adelphia's equipment and components, extending power cabling to the BellSouth power distribution frame, performing operational tests after installation is complete, and notifying BellSouth's equipment engineers and Adelphia upon successful completion of installation, etc. The BellSouth Certified Supplier shall bill Adelphia directly for all work performed for Adelphia pursuant to this Attachment, and BellSouth shall have no liability for nor responsibility to pay such charges imposed by the BellSouth Certified Supplier. BellSouth shall make available its supplier certification program to Adelphia or any supplier proposed by Adelphia and will not unreasonably withhold certification. All work performed by or for Adelphia shall conform to generally accepted industry guidelines and standards.
- 7.7 Alarm and Monitoring. BellSouth shall place environmental alarms in the Premises for the protection of BellSouth equipment and facilities. Adelphia shall be responsible for placement, monitoring and removal of environmental and equipment alarms used to service Adelphia's Collocation Space. Upon request, BellSouth will provide Adelphia with applicable tariffed service(s) to facilitate remote monitoring of collocated equipment by Adelphia. Both Parties shall use best efforts to notify the other of any verified environmental condition known to that Party.
- 7.8 Virtual to Physical Collocation Relocation. In the event physical Collocation Space was previously denied at a location due to technical reasons or space limitations, and physical Collocation Space has subsequently become available, Adelphia may relocate

- its virtual collocation arrangements to physical collocation arrangements and pay the appropriate fees for physical collocation and for the rearrangement or reconfiguration of services terminated in the virtual collocation arrangement, as outlined in the appropriate BellSouth tariffs. In the event that BellSouth knows when additional space for physical collocation may become available at the location requested by Adelphia, such information will be provided to Adelphia in BellSouth's written denial of physical collocation. To the extent that (i) physical Collocation Space becomes available to Adelphia within one hundred eighty (180) calendar days of BellSouth's written denial of Adelphia's request for physical collocation, (ii) BellSouth had knowledge that the space was going to become available, and (iii) Adelphia was not informed in the written denial that physical Collocation Space would become available within such one hundred eighty (180) calendar days, then Adelphia may relocate its virtual collocation arrangement to a physical collocation arrangement and will receive a credit for any nonrecurring charges previously paid for such virtual collocation. Adelphia must arrange with a BellSouth Certified Supplier for the relocation of equipment from its virtual Collocation Space to its physical Collocation Space and will bear the cost of such relocation.
- 7.9 Virtual to Physical Conversion (In-Place). Virtual collocation arrangements may be converted to "in-place" physical arrangements if the potential conversion meets the following four criteria: 1) there is no change in the amount of equipment or the configuration of the equipment that was in the virtual collocation arrangement; 2) the conversion of the virtual collocation arrangement will not cause the equipment or the results of that conversion to be located in a space that BellSouth has reserved for its own future needs; 3) the converted arrangement does not limit BellSouth's ability to secure its own equipment and facilities due to the location of the virtual collocation arrangement; and 4) any changes to the arrangement can be accommodated by existing power, HVAC, and other requirements. Unless otherwise specified, BellSouth will complete virtual to in-place physical collocation conversions within sixty (60) calendar days from receipt of the BFFO. BellSouth will bill Adelphia an Administrative Only Application Fee as set forth in Exhibit B for these changes on the date that BellSouth provides an Application Response.
- 7.10 Cancellation. If, at any time prior to space acceptance, Adelphia cancels its order for the Collocation Space(s) ("Cancellation"), BellSouth will bill the applicable non-recurring rate for any and all work processes for which work has begun.
- 7.11 Licenses. Adelphia, at its own expense, will be solely responsible for obtaining from governmental authorities, and any other appropriate agency, entity, or person, all rights, privileges, and licenses necessary or required to operate as a provider of telecommunications services to the public or to occupy the Collocation Space.
- 7.12 Environmental Compliance. The Parties agree to utilize and adhere to the Environmental Hazard Guidelines identified in Exhibit A attached hereto.

8. Rates and Charges

- 8.1 Recurring Charges. If Adelphia has met the applicable fifteen (15) calendar day walk-through interval(s) specified in Section 4, billing for recurring charges will begin upon the Space Acceptance Date. In the event that Adelphia fails to complete an acceptance walk-through within the applicable fifteen (15) calendar day interval(s), billing for recurring charges will commence on the Space Ready Date or on the Space Acceptance Date, whichever is sooner.
- 8.2 Application Fee. BellSouth shall assess an application fee via a service order, which shall be issued at the time BellSouth responds that space is available pursuant to Section 6 (Application Response). Payment of said application fee will be due as dictated by Adelphia's current billing cycle and is non-refundable.
- 8.3 Space Preparation. Space preparation fees consist of a nonrecurring charge for firm order processing and monthly recurring charges for central office modifications, assessed per arrangement, per square foot, and common systems modifications, assessed per arrangement, per square foot, for cageless collocation and per cage for caged collocation. Adelphia shall remit payment of the nonrecurring firm order-processing fee coincident with submission of a BFFO. The charges recover the costs associated with preparing the Collocation Space, which includes survey, engineering of the Collocation Space, design and modification costs for network, building and support systems. In the event Adelphia opts for cageless space, the space preparation fees will be assessed based on the total floor space dedicated to Adelphia as prescribed in this Section.
- 8.4 Cable Installation. Cable Installation Fee(s) are assessed per entrance cable placed. This non-recurring fee will be billed by BellSouth upon receipt of the Adelphia's BFFO.
- 8.5 Floor Space. The Floor Space Charge includes reasonable charges for lighting, HVAC, and other allocated expenses associated with maintenance of the Premises but does not include any power-related costs incurred by BellSouth. When the Collocation Space is enclosed, Adelphia shall pay floor space charges based upon the number of square feet so enclosed. When the Collocation Space is not enclosed, Adelphia shall pay floor space charges based upon the following floor space calculation: [(depth of the equipment lineup in which the rack is placed) + (0.5 x maintenance aisle depth) + (0.5 x wiring aisle depth)] X (width of rack and spacers). For purposes of this calculation, the depth of the equipment lineup shall consider the footprint of equipment racks plus any equipment overhang. BellSouth will assign unenclosed Collocation Space in conventional equipment rack lineups where feasible. In the event Adelphia's collocated equipment requires special cable racking, isolated grounding or other treatment which prevents placement within conventional equipment rack lineups, Adelphia shall be required to request an amount of floor space sufficient to accommodate the total equipment arrangement.

- 8.6 Power. BellSouth shall make available –48 Volt (-48V) DC power for Adelphia's Collocation Space at a BellSouth Power Board or BellSouth Battery Distribution Fuse Bay (BDFB) at Adelphia's option within the Premises.
- 8.6.1 When obtaining power from a BDFB, fuses and power cables (A&B) must be engineered (sized), and installed by Adelphia's BellSouth Certified Supplier. When obtaining power from a BellSouth power board, power cables (A&B) must be engineered (sized), and installed by Adelphia's BellSouth Certified Supplier. Adelphia is responsible for contracting with a BellSouth Certified Supplier for power distribution feeder cable runs from a BellSouth BDFB or power board to Adelphia's equipment. The determination of the BellSouth BDFB or BellSouth power board as the power source will be made at BellSouth's sole, but reasonable, discretion. The BellSouth Certified Supplier contracted by Adelphia must provide BellSouth a copy of the engineering power specification prior to the day on which Adelphia's equipment becomes operational. BellSouth will provide the common power feeder cable support structure between the BellSouth BDFB or power board and Adelphia's arrangement area. Adelphia shall contract with a BellSouth Certified Supplier who will be responsible for the following: dedicated power cable support structure within Adelphia's arrangement, power cable feeds, and terminations of cable. Any terminations at a BellSouth power board must be performed by a BellSouth Certified Supplier. Adelphia shall comply with all applicable National Electric Code (NEC), BellSouth TR73503, Telcordia and ANSI Standards regarding power cabling.
- 8.6.2 If Adelphia elects to install its own DC Power Plant, BellSouth shall provide AC power to feed Adelphia's DC Power Plant. Charges for AC power will be assessed per breaker ampere per month. Rates include the provision of commercial and standby AC power. When obtaining power from a BellSouth service panel, protection devices and power cables must be engineered (sized), and installed by Adelphia's BellSouth Certified Supplier except that BellSouth shall engineer and install protection devices and power cables for Adjacent Collocation. Adelphia's BellSouth Certified Supplier must also provide a copy of the engineering power specification prior to the equipment becoming operational. Charges for AC power shall be assessed pursuant to the rates specified in Exhibit B. AC power voltage and phase ratings shall be determined on a per location basis. At Adelphia's option, Adelphia may arrange for AC power in an Adjacent Collocation arrangement from a retail provider of electrical power.
- 8.6.3 If Adelphia requests a reduction in the amount of power that BellSouth is currently providing Adelphia must submit a Subsequent Application. If no modification to the Collocation Space is requested other than the reduction in power, the Subsequent Application Fee for Power Reduction as set forth in Exhibit B will apply. If modifications are requested in addition to the reduction of power the Subsequent Application Fee will apply. This non-recurring fee will be billed by BellSouth on the date that BellSouth provides an Application Response.
- 8.7 Security Escort. A security escort will be required whenever Adelphia or its approved agent desires access to the entrance manhole or must have access to the Premises after

- the one accompanied site visit allowed pursuant to Section 5 prior to completing BellSouth's Security Training requirements. Rates for a security escort are assessed according to the schedule appended hereto as Exhibit B beginning with the scheduled escort time. BellSouth will wait for one-half (1/2) hour after the scheduled time for such an escort and Adelphia shall pay for such half-hour charges in the event Adelphia fails to show up.
- 8.8 Cable Record charges. These charges apply for work required to build cable records in BellSouth systems. The VG/DS0 per cable record charge is for a maximum of 3600 records. The Fiber cable record charge is for a maximum of 99 records. These non-recurring fees will be billed upon receipt of Adelphia's BFFO.
- 8.9 Other. If no rate is identified in the contract, the rate for the specific service or function will be negotiated by the Parties upon request by either Party.
- 9. Insurance**
- 9.1 Adelphia shall, at its sole cost and expense, procure, maintain, and keep in force insurance as specified in this Section and underwritten by insurance companies licensed to do business in the states applicable under this Attachment and having a Best's Insurance Rating of A-.
- 9.2 Adelphia shall maintain the following specific coverage:
- 9.2.1 Commercial General Liability coverage in the amount of ten million dollars (\$10,000,000.00) or a combination of Commercial General Liability and Excess/Umbrella coverage totaling not less than ten million dollars (\$10,000,000.00). BellSouth shall be named as an Additional Insured on the Commercial General Liability policy as specified herein.
- 9.2.2 Statutory Workers Compensation coverage and Employers Liability coverage in the amount of one hundred thousand dollars (\$100,000.00) each accident, one hundred thousand dollars (\$100,000.00) each employee by disease, and five hundred thousand dollars (\$500,000.00) policy limit by disease.
- 9.2.3 All Risk Property coverage on a full replacement cost basis insuring all of Adelphia's real and personal property situated on or within BellSouth's Central Office location(s).
- 9.2.4 Adelphia may elect to purchase business interruption and contingent business interruption insurance, having been advised that BellSouth assumes no liability for loss of profit or revenues should an interruption of service occur.
- 9.3 The limits set forth in Section 9.2 above may be increased by BellSouth from time to time during the term of this Attachment upon thirty (30) calendar days notice to Adelphia to at least such minimum limits as shall then be customary with respect to comparable occupancy of BellSouth structures.

- 9.4 All policies purchased by Adelphia shall be deemed to be primary and not contributing to or in excess of any similar coverage purchased by BellSouth. All insurance must be in effect on or before the date equipment is delivered to BellSouth's Premises and shall remain in effect for the term of this Attachment or until all Adelphia's property has been removed from BellSouth's Premises, whichever period is longer. If Adelphia fails to maintain required coverage, BellSouth may pay the premiums thereon and seek reimbursement of same from Adelphia.
- 9.5 Adelphia shall submit certificates of insurance reflecting the coverage required pursuant to this Section a minimum of ten (10) business days prior to the commencement of any work in the Collocation Space. Failure to meet this interval may result in construction and equipment installation delays. Adelphia shall arrange for BellSouth to receive thirty (30) business days' advance notice of cancellation from Adelphia's insurance company. Adelphia shall forward a certificate of insurance and notice of cancellation/non-renewal to BellSouth at the following address:
- BellSouth Telecommunications, Inc.
Attn.: Risk Management Coordinator
17H53 BellSouth Center
675 W. Peachtree Street
Atlanta, Georgia 30375
- 9.6 Adelphia must conform to recommendations made by BellSouth's fire insurance company to the extent BellSouth has agreed to, or shall hereafter agree to, such recommendations.
- 9.7 Self-Insurance. If Adelphia's net worth exceeds five hundred million dollars (\$500,000,000), Adelphia may elect to request self-insurance status in lieu of obtaining any of the insurance required in Sections 9.2.1 and 9.2.2. Adelphia shall provide audited financial statements to BellSouth thirty (30) calendar days prior to the commencement of any work in the Collocation Space. BellSouth shall then review such audited financial statements and respond in writing to Adelphia in the event that self-insurance status is not granted to Adelphia. If BellSouth approves Adelphia for self-insurance, Adelphia shall annually furnish to BellSouth, and keep current, evidence of such net worth that is attested to by one of Adelphia's corporate officers. The ability to self-insure shall continue so long as the Adelphia meets all of the requirements of this Section. If Adelphia subsequently no longer satisfies this Section, Adelphia is required to purchase insurance as indicated by Sections 9.2.1 and 9.2.2.
- 9.8 The net worth requirements set forth in Section 9.7 may be increased by BellSouth from time to time during the term of this Attachment upon thirty (30) calendar days' notice to Adelphia to at least such minimum limits as shall then be customary with respect to comparable occupancy of BellSouth structures.
- 9.9 Failure to comply with the provisions of this Section will be deemed a material breach of this Attachment.

10. Mechanics Liens

10.1 If any mechanics lien or other liens shall be filed against property of either Party (BellSouth or Adelphia), or any improvement thereon by reason of or arising out of any labor or materials furnished or alleged to have been furnished or to be furnished to or for the other Party or by reason of any changes, or additions to said property made at the request or under the direction of the other Party, the other Party directing or requesting those changes shall, within thirty (30) business days after receipt of written notice from the Party against whose property said lien has been filed, either pay such lien or cause the same to be bonded off the affected property in the manner provided by law. The Party causing said lien to be placed against the property of the other shall also defend, at its sole cost and expense, on behalf of the other, any action, suit or proceeding which may be brought for the enforcement of such liens and shall pay any damage and discharge any judgment entered thereon.

11. Inspections

11.1 BellSouth may conduct an inspection of Adelphia's equipment and facilities in the Collocation Space(s) prior to the activation of facilities between Adelphia's equipment and equipment of BellSouth. BellSouth may conduct an inspection if Adelphia adds equipment and may otherwise conduct routine inspections at reasonable intervals mutually agreed upon by the Parties. BellSouth shall provide Adelphia with a minimum of forty-eight (48) hours or two (2) business days, whichever is greater, advance notice of all such inspections. All costs of such inspection shall be borne by BellSouth.

12. Security and Safety Requirements

12.1 Unless otherwise specified, Adelphia will be required, at its own expense, to conduct a statewide investigation of criminal history records for each Adelphia employee hired in the past five years being considered for work on the BellSouth Premises, for the states/counties where the Adelphia employee has worked and lived for the past five years. Where state law does not permit statewide collection or reporting, an investigation of the applicable counties is acceptable. Adelphia shall not be required to perform this investigation if an affiliated company of Adelphia has performed an investigation of the Adelphia employee seeking access, if such investigation meets the criteria set forth above. This requirement will not apply if Adelphia has performed a pre-employment statewide investigation of criminal history records of the Adelphia employee for the states/counties where the Adelphia employee has worked and lived for the past five years or, where state law does not permit a statewide investigation, an investigation of the applicable counties.

12.2 Adelphia will be required to administer to its personnel assigned to the BellSouth Premises security training either provided by BellSouth, or meeting criteria defined by BellSouth.

- 12.3 Adelphia shall provide its employees and agents with picture identification, which must be worn and visible at all times while in the Collocation Space or other areas in or around the Premises. The photo identification card shall bear, at a minimum, the employee's name and photo and Adelphia's name. BellSouth reserves the right to remove from its Premises any employee of Adelphia not possessing identification issued by Adelphia or who has violated any of BellSouth's policies as outlined in the CLEC Security Training documents. Adelphia shall hold BellSouth harmless for any damages resulting from such removal of its personnel from BellSouth Premises. Adelphia shall be solely responsible for ensuring that any Guest of Adelphia is in compliance with all subsections of this Section.
- 12.4 Adelphia shall not assign to the BellSouth Premises any personnel with records of felony criminal convictions. Adelphia shall not assign to the BellSouth Premises any personnel with records of misdemeanor convictions, except for misdemeanor traffic violations, without advising BellSouth of the nature and gravity of the offense(s). BellSouth reserves the right to refuse building access to any Adelphia personnel who have been identified to have misdemeanor criminal convictions. Notwithstanding the foregoing, in the event that Adelphia chooses not to advise BellSouth of the nature and gravity of any misdemeanor conviction, Adelphia may, in the alternative, certify to BellSouth that it shall not assign to the BellSouth Premises any personnel with records of misdemeanor convictions (other than misdemeanor traffic violations).
- 12.4.1 Adelphia shall not knowingly assign to the BellSouth Premises any individual who was a former employee of BellSouth and whose employment with BellSouth was terminated for a criminal offense whether or not BellSouth sought prosecution of the individual for the criminal offense.
- 12.4.2 Adelphia shall not knowingly assign to the BellSouth Premises any individual who was a former supplier of BellSouth and whose access to a BellSouth Premises was revoked due to commission of a criminal offense whether or not BellSouth sought prosecution of the individual for the criminal offense.
- 12.5 For each Adelphia employee or agent hired by Adelphia within five years of being considered for work on the BellSouth Premises, who requires access to a BellSouth Premises pursuant to this Attachment, Adelphia shall furnish BellSouth, prior to an employee or agent gaining such access, a certification that the aforementioned background check and security training were completed. The certification will contain a statement that no felony convictions were found and certifying that the security training was completed by the employee. If the employee's criminal history includes misdemeanor convictions, Adelphia will disclose the nature of the convictions to BellSouth at that time. In the alternative, Adelphia may certify to BellSouth that it shall not assign to the BellSouth Premises any personnel with records of misdemeanor convictions other than misdemeanor traffic violations.
- 12.5.1 For all other Adelphia employees requiring access to a BellSouth Premises pursuant to this Attachment, Adelphia shall furnish BellSouth, prior to an employee gaining such

access, a certification that the employee is not subject to the requirements of Section 12.5 above and that security training was completed by the employee.

- 12.6 At BellSouth's request, Adelphia shall promptly remove from BellSouth's Premises any employee of Adelphia BellSouth does not wish to grant access to its Premises 1) pursuant to any investigation conducted by BellSouth or 2) prior to the initiation of an investigation if an employee of Adelphia is found interfering with the property or personnel of BellSouth or another collocated telecommunications carrier, provided that an investigation shall promptly be commenced by BellSouth.
- 12.7 Security Violations. BellSouth reserves the right to interview Adelphia's employees, agents, or suppliers in the event of wrongdoing in or around BellSouth's property or involving BellSouth's or another telecommunications carrier's property or personnel, provided that BellSouth shall provide reasonable notice to Adelphia's Security contact of such interview. Adelphia and its suppliers shall reasonably cooperate with BellSouth's investigation into allegations of wrongdoing or criminal conduct committed by, witnessed by, or involving Adelphia's employees, agents, or suppliers. Additionally, BellSouth reserves the right to bill Adelphia for all reasonable costs associated with investigations involving its employees, agents, or suppliers if it is established and mutually agreed in good faith that Adelphia's employees, agents, or suppliers are responsible for the alleged act. BellSouth shall bill Adelphia for BellSouth property, which is stolen or damaged where an investigation determines the culpability of Adelphia's employees, agents, or suppliers and where Adelphia agrees, in good faith, with the results of such investigation. Adelphia shall notify BellSouth in writing immediately in the event that Adelphia discovers one of its employees already working on the BellSouth Premises is a possible security risk. Upon request of the other Party, the Party who is the employer shall discipline consistent with its employment practices, up to and including removal from BellSouth Premises, any employee found to have violated the security and safety requirements of this Section. Adelphia shall hold BellSouth harmless for any damages resulting from such removal of its personnel from BellSouth Premises.
- 12.8 Use of Supplies. Unauthorized use of equipment, supplies or other property by either Party, whether or not used routinely to provide telephone service will be strictly prohibited and handled appropriately. Costs associated with such unauthorized use may be charged to the offending Party, as may be all associated investigative costs.
- 12.9 Use of Official Lines. Except for non-toll calls necessary in the performance of their work, neither Party shall use the telephones of the other Party on the BellSouth Premises. Charges for unauthorized telephone calls may be charged to the offending Party, as may be all associated investigative costs.
- 12.10 Accountability. Full compliance with the Security requirements of this Section shall in no way limit the accountability of either Party to the other for the improper actions of its employees.

13. Destruction of Collocation Space

- 13.1 In the event a Collocation Space is wholly or partially damaged by fire, windstorm, tornado, flood or by similar causes to such an extent as to be rendered wholly unsuitable for Adelphia's permitted use hereunder, then either Party may elect within ten (10) calendar days after such damage, to terminate occupancy of the damaged Collocation Space, and if either Party shall so elect, by giving the other written notice of termination, both Parties shall stand released of and from further liability under the terms hereof. If the Collocation Space shall suffer only minor damage and shall not be rendered wholly unsuitable for Adelphia's permitted use, or is damaged and the option to terminate is not exercised by either Party, BellSouth covenants and agrees to proceed promptly without expense to Adelphia, except for improvements not the property of BellSouth, to repair the damage. BellSouth shall have a reasonable time within which to rebuild or make any repairs, and such rebuilding and repairing shall be subject to delays caused by storms, shortages of labor and materials, government regulations, strikes, walkouts, and causes beyond the control of BellSouth, which causes shall not be construed as limiting factors, but as exemplary only. Adelphia may, at its own expense, accelerate the rebuild of its collocated space and equipment provided however that a BellSouth Certified Supplier is used and the necessary space preparation has been completed. If Adelphia's acceleration of the project increases the cost of the project, then those additional charges will be incurred by Adelphia. Where allowed and where practical, Adelphia may erect a temporary facility while BellSouth rebuilds or makes repairs. In all cases where the Collocation Space shall be rebuilt or repaired, Adelphia shall be entitled to an equitable abatement of rent and other charges, depending upon the unsuitability of the Collocation Space for Adelphia's permitted use, until such Collocation Space is fully repaired and restored and Adelphia's equipment installed therein (but in no event later than thirty (30) calendar days after the Collocation Space is fully repaired and restored). Where Adelphia has placed an Adjacent Arrangement pursuant to Section 3, Adelphia shall have the sole responsibility to repair or replace said Adjacent Arrangement provided herein. Pursuant to this Section, BellSouth will restore the associated services to the Adjacent Arrangement.

14. Eminent Domain

- 14.1 If the whole of a Collocation Space or Adjacent Arrangement shall be taken by any public authority under the power of eminent domain, then this Attachment shall terminate with respect to such Collocation Space or Adjacent Arrangement as of the day possession shall be taken by such public authority and rent and other charges for the Collocation Space or Adjacent Arrangement shall be paid up to that day with proportionate refund by BellSouth of such rent and charges as may have been paid in advance for a period subsequent to the date of the taking. If any part of the Collocation Space or Adjacent Arrangement shall be taken under eminent domain, BellSouth and Adelphia shall each have the right to terminate this Attachment with respect to such Collocation Space or Adjacent Arrangement and declare the same null

and void, by written notice of such intention to the other Party within ten (10) calendar days after such taking.

15. Nonexclusivity

- 15.1 Adelphia understands that this Attachment is not exclusive and that BellSouth may enter into similar agreements with other Parties. Assignment of space pursuant to all such agreements shall be determined by space availability and made on a first come, first served basis

ENVIRONMENTAL AND SAFETY PRINCIPLES

The following principles provide basic guidance on environmental and safety issues when applying for and establishing Physical Collocation arrangements.

1. GENERAL PRINCIPLES

- 1.1 Compliance with Applicable Law. BellSouth and Adelphia agree to comply with applicable federal, state, and local environmental and safety laws and regulations including U.S. Environmental Protection Agency (USEPA) regulations issued under the Clean Air Act (CAA), Clean Water Act (CWA), Resource Conservation and Recovery Act (RCRA), Comprehensive Environmental Response, Compensation and Liability Act (CERCLA), Superfund Amendments and Reauthorization Act (SARA), the Toxic Substances Control Act (TSCA), and OSHA regulations issued under the Occupational Safety and Health Act of 1970, as amended and NFPA and National Electrical Codes (NEC) and the NESC (“Applicable Laws”). Each Party shall notify the other if compliance inspections are conducted by regulatory agencies and/or citations are issued that relate to any aspect of this Attachment.
- 1.2 Notice. BellSouth and Adelphia shall provide notice to the other, including Material Safety Data Sheets (MSDSs), of known and recognized physical hazards or Hazardous Chemicals existing on site or brought on site. A Hazardous Chemical inventory list is posted on an OSHA Poster and updated annually at each Central Office. This Poster is normally located near the front entrance of the building or in the lounge area. Each Party is required to provide specific notice for known potential Imminent Danger conditions. Adelphia should contact 1-800-743-6737 for any BellSouth MSDS required.
- 1.3 Practices/Procedures. BellSouth may make available additional environmental control procedures for Adelphia to follow when working at a BellSouth Premises (See Section 2, below). These practices/procedures will represent the regular work practices required to be followed by the employees and suppliers of BellSouth for environmental protection. Adelphia will require its suppliers, agents and others accessing the BellSouth Premises to comply with these practices. Section 2 lists the Environmental categories where BST practices should be followed by Adelphia when operating in the BellSouth Premises.
- 1.4 Environmental and Safety Inspections. BellSouth reserves the right to inspect the Adelphia space with proper notification. BellSouth reserves the right to stop any Adelphia work operation that imposes Imminent Danger to the environment, employees or other persons in the area or Premises.
- 1.5 Hazardous Materials Brought On Site. Any hazardous materials brought into, used, stored or abandoned at the BellSouth Premises by Adelphia are owned by Adelphia. Adelphia will indemnify BellSouth for claims, lawsuits or damages to persons or property caused by these materials. Without prior written BellSouth approval, no substantial new safety or environmental hazards can be created by Adelphia or different hazardous materials used by Adelphia at BellSouth Premises. Adelphia must demonstrate adequate emergency response capabilities for its materials used or remaining at the BellSouth Premises.

- 1.6 Spills and Releases. When contamination is discovered at a BellSouth Premises, the Party discovering the condition must notify BellSouth. All Spills or Releases of regulated materials will immediately be reported by Adelphia to BellSouth.
- 1.7 Coordinated Environmental Plans and Permits. BellSouth and Adelphia will coordinate plans, permits or information required to be submitted to government agencies, such as emergency response plans, spill prevention control and countermeasures (SPCC) plans and community reporting. If fees are associated with filing, BellSouth and Adelphia will develop a cost sharing procedure. If BellSouth’s permit or EPA identification number must be used, Adelphia must comply with all of BellSouth’s permit conditions and environmental processes, including environmental “best management practices (BMP)” (see Section 2, below) and/or selection of BST disposition vendors and disposal sites.
- 1.8 Environmental and Safety Indemnification. BellSouth and Adelphia shall indemnify, defend and hold harmless the other Party from and against any claims (including, without limitation, third-party claims for personal injury or death or real or personal property damage), judgments, damages (including direct and indirect damages and punitive damages), penalties, fines, forfeitures, costs, liabilities, interest and losses arising in connection with the violation or alleged violation of any Applicable Law or contractual obligation or the presence or alleged presence of contamination arising out of the acts or omissions of the indemnifying Party, its agents, suppliers, or employees concerning its operations at the Premises.

2. CATEGORIES FOR CONSIDERATION OF ENVIRONMENTAL ISSUES

- 2.1 When performing functions that fall under the following Environmental categories on BellSouth’s Premises, Adelphia agrees to comply with the applicable sections of the current issue of BellSouth’s Environmental and Safety Methods and Procedures (M&Ps), incorporated herein by this reference. Adelphia further agrees to cooperate with BellSouth to ensure that Adelphia’s employees, agents, and/or suppliers are knowledgeable of and satisfy those provisions of BellSouth’s Environmental M&Ps which apply to the specific Environmental function being performed by Adelphia, its employees, agents and/or suppliers.
- 2.2 The most current version of the reference documentation must be requested from Adelphia’s BellSouth Account Team Collocation Coordinator (ATCC) Representative.

| ENVIRONMENTAL CATEGORIES | ENVIRONMENTAL ISSUES | ADDRESSED BY THE FOLLOWING DOCUMENTATION |
|--|---|---|
| Disposal of hazardous material or other regulated material (e.g., batteries, fluorescent tubes, solvents & cleaning materials) | Compliance with all applicable local, state, & federal laws and regulations Pollution liability insurance EVET approval of supplier | Std T&C 450 Fact Sheet Series 17000 Std T&C 660-3 Approved Environmental Vendor List (Contact ATCC |

| | | |
|---|---|---|
| | | Representative) |
| Emergency response | Hazmat/waste release/spill fire safety emergency | Fact Sheet Series 17000 Building Emergency Operations Plan (EOP) (specific to and located on Premises) |
| Contract labor/outsourcing for services with environmental implications to be performed on BellSouth Premises (e.g., disposition of hazardous material/waste; maintenance of storage tanks) | Compliance with all applicable local, state, & federal laws and regulations Performance of services in accordance with BST's environmental M&Ps Insurance | Std T&C 450 Std T&C 450-B (Contact ATCC Representative for copy of appropriate E/S M&Ps.) Std T&C 660 |
| Transportation of hazardous material | Compliance with all applicable local, state, & federal laws and regulations Pollution liability insurance EVET approval of supplier | Std T&C 450 Fact Sheet Series 17000 Std T&C 660-3 Approved Environmental Vendor List (Contact ATCC Representative) |
| Maintenance/operations work which may produce a waste Other maintenance work | Compliance with all applicable local, state, & federal laws and regulations Protection of BST employees and equipment | Std T&C 450 29CFR 1910.147 (OSHA Standard) 29CFR 1910 Subpart O (OSHA Standard) |
| Janitorial services | All waste removal and disposal must conform to all applicable federal, state and local regulations All Hazardous Material and Waste Asbestos notification and protection of employees and | Procurement Manager (CRES Related Matters)-BST Supply Chain Services Fact Sheet Series 17000 GU-BTEN-001BT, Chapter 3 BSP 010-170-001BS (Hazcom) |

| | | |
|---|--|---|
| | equipment | |
| Manhole cleaning | <p>Compliance with all applicable local, state, & federal laws and regulations</p> <p>Pollution liability insurance</p> <p>EVET approval of supplier</p> | <p>Std T&C 450 Fact Sheet 14050 BSP 620-145-011PR Issue A, August 1996</p> <p>Std T&C 660-3</p> <p>Approved Environmental Vendor List (Contact ATCC Representative)</p> |
| Removing or disturbing building materials that may contain asbestos | Asbestos work practices | <p>GU-BTEN-001BT, Chapter 3 For questions regarding removing or disturbing materials that contain asbestos, call the BellSouth Building Service Center: AL, MS, TN, KY & LA (local area code) 557-6194 FL, GA, NC & SC (local area code) 780-2740</p> |

3. DEFINITIONS

Generator. Under RCRA, the person whose act produces a Hazardous Waste, as defined in 40 CFR 261, or whose act first causes a Hazardous Waste to become subject to regulation. The Generator is legally responsible for the proper management and disposal of Hazardous Wastes in accordance with regulations.

Hazardous Chemical. As defined in the U.S. Occupational Safety and Health (OSHA) hazard communication standard (29 CFR 1910.1200), any chemical which is a health hazard or physical hazard.

Hazardous Waste. As defined in Section 1004 of RCRA.

Imminent Danger. Any conditions or practices at a facility which are such that a danger exists which could reasonably be expected to cause immediate death or serious harm to people or immediate significant damage to the environment or natural resources.

Spill or Release. As defined in Section 101 of CERCLA.

4. ACRONYMS

ATCC – Account Team Collocation Coordinator

BST – BellSouth Telecommunications

Version 3Q02: 09/06/02

CRES – Corporate Real Estate and Services (formerly PS&M)

DEC/LDEC - Department Environmental Coordinator/Local Department Environmental Coordinator

E/S – Environmental/Safety

EVET - Environmental Vendor Evaluation Team

GU-BTEN-001BT - BellSouth Environmental Methods and Procedures

NESC - National Electrical Safety Codes

P&SM - Property & Services Management

Std T&C - Standard Terms & Conditions

Attachment 4

Remote Site Physical Collocation

BELLSOUTH

REMOTE SITE PHYSICAL COLLOCATION

1. Scope of Attachment

1.1 Scope of Attachment. The rates, terms, and conditions contained within this Attachment shall only apply when Adelphia is occupying the Remote Collocation Space as a sole occupant or as a Host within a Remote Site Location pursuant to this Attachment.

1.2 Right to occupy. BellSouth shall offer to Adelphia Remote Site Collocation on rates, terms, and conditions that are just, reasonable, non-discriminatory and consistent with the rules of the Federal Communications Commission (“FCC”). Subject to the rates, terms, and conditions of this Attachment where space is available and collocation is technically feasible, BellSouth will allow Adelphia to occupy that certain area designated by BellSouth within a BellSouth Remote Site Location, or on BellSouth property upon which the BellSouth Remote Site Location is located, of a size, which is specified by Adelphia and agreed to by BellSouth (hereinafter “Remote Collocation Space”). BellSouth Remote Site Locations include cabinets, huts, and controlled environmental vaults owned or leased by BellSouth that house BellSouth Network Facilities. To the extent this Attachment does not include all the necessary rates, terms and conditions for BellSouth remote locations other than cabinets, huts and controlled environmental vaults, the Parties will negotiate said rates, terms, and conditions upon request for collocation at BellSouth remote locations other than those specified above.

1.3 Space Reservation.

1.3.1 In all states other than Florida, the number of racks/bays specified by Adelphia may contemplate a request for space sufficient to accommodate Adelphia’s growth within a two year period.

1.3.2 Neither BellSouth nor any of BellSouth’s affiliates may reserve space for future use on more preferential terms than those set forth above.

1.3.3 Intentionally Left Blank

1.4 Third Party Property. If the Premises, or the property on which it is located, is leased by BellSouth from a Third Party or otherwise controlled by a Third Party, special considerations and intervals may apply in addition to the terms and conditions of this Attachment. Additionally, where BellSouth notifies Adelphia that BellSouth’s

- agreement with a Third Party does not grant BellSouth the ability to provide access and use rights to others, upon Adelphia's request, BellSouth will use its best efforts to obtain the owner's consent and to otherwise secure such rights for Adelphia. Adelphia agrees to reimburse BellSouth for the reasonable and demonstrable costs incurred by BellSouth in obtaining such rights for Adelphia. In cases where a Third Party agreement does not grant BellSouth the right to provide access and use rights to others as contemplated by this Attachment and BellSouth, despite its best efforts, is unable to secure such access and use rights for Adelphia as above, Adelphia shall be responsible for obtaining such permission to access and use such property. BellSouth shall cooperate with Adelphia in obtaining such permission.
- 1.5 Space Reclamation. In the event of space exhaust within a Remote Site Location, BellSouth may include in its documentation for the Petition for Waiver filing any unutilized space in the Remote Site Location. Adelphia will be responsible for any justification of unutilized space within its Remote Collocation Space, if the Commission requires such justification.
- 1.6 Use of Space. Adelphia shall use the Remote Collocation Space for the purposes of installing, maintaining and operating Adelphia's equipment (to include testing and monitoring equipment) necessary for interconnection with BellSouth services and facilities or for accessing BellSouth unbundled network elements (UNEs) for the provision of telecommunications services, as specifically set forth in this Attachment. The Remote Collocation Space may be used for no other purposes except as specifically described herein or in any amendment hereto.
- 1.7 Rates and charges. Adelphia agrees to pay the rates and charges identified in Exhibit B attached hereto.
- 1.8 If any due date contained in this Attachment falls on a weekend or National holiday, then the due date will be the next business day thereafter. For intervals of ten (10) calendar days or less National holidays will be excluded.
- 1.9 The Parties agree to comply with all applicable federal, state, county, local and administrative laws, rules, ordinances, regulations and codes in the performance of their obligations hereunder.
2. **Space Availability Report**
- 2.1 Space Availability Report. Upon request from Adelphia, BellSouth will provide a written report ("Space Availability Report"), describing in detail the space that is available for collocation and specifying the amount of Remote Collocation Space available at the Remote Site Location requested, the number of collocators present at the Remote Site Location, any modifications in the use of the space since the last report on the Remote Site Location requested and the measures BellSouth is taking to

- make additional space available for collocation arrangements. A Space Availability Report does not reserve space at the Remote Site Location.
- 2.1.1 The request from Adelphia for a Space Availability Report must be written and must include the Common Language Location Identification (“CLLI”) code for both the Remote Site Location and the serving wire center. The CLLI code information for the serving wire center is located in the National Exchange Carriers Association (NECA) Tariff FCC No. 4. If Adelphia is unable to obtain the CLLI code for the Remote Site Location from, for example, a site visit to the remote site, Adelphia may request the CLLI code from BellSouth. To obtain a CLLI code for a Remote Site Location directly from BellSouth, Adelphia should submit to BellSouth a Remote Site Interconnection Request for the serving wire center CLLI code prior to submitting its request for a Space Availability Report. Adelphia should complete all the requested information and submit the Request to BellSouth. BellSouth will bill the applicable fee upon receipt of the request.
- 2.1.2 BellSouth will respond to a request for a Space Availability Report for a particular Remote Site Location within ten (10) calendar days of receipt of such request. BellSouth will make best efforts to respond in ten (10) calendar days to such a request when the request includes from two (2) to five (5) Remote Site Locations within the same state. The response time for requests of more than five (5) Remote Site Locations shall be negotiated between the Parties. If BellSouth cannot meet the ten (10) calendar day response time, BellSouth shall notify Adelphia and inform Adelphia of the time frame under which it can respond.
- 2.2 Remote Terminal information. Upon request, BellSouth will provide Adelphia with the following information concerning BellSouth’s remote terminals: (i) the address of the remote terminal; (ii) the CLLI code of the remote terminal; (iii) the carrier serving area of the remote terminal; (iv) the designation of which remote terminals subtend a particular central office; and (v) the number and address of customers that are served by a particular remote terminal.
- 2.2.1 BellSouth will provide this information on a first come, first served basis within thirty (30) calendar days of a Adelphia request subject to the following conditions: (i) the information will only be provided on a CD in the same format in which it appears in BellSouth’s systems; (ii) the information will only be provided for each serving wire center designated by Adelphia, up to a maximum of thirty (30) wire centers per Adelphia request per month per state, and up to for a maximum of 120 wire centers total per month per state for all CLECs; and (iii) Adelphia agrees to pay the costs incurred by BellSouth in providing the information.

3. Collocation Options

- 3.1 Cageless. BellSouth shall allow Adelphia to collocate Adelphia's equipment and facilities without requiring the construction of a cage or similar structure. BellSouth shall allow Adelphia to have direct access to Adelphia's equipment and facilities. BellSouth shall make cageless collocation available in single rack/bay increments. Except where Adelphia's equipment requires special technical considerations (e.g., special cable racking, isolated ground plane, etc.), BellSouth shall assign cageless Remote Collocation Space in conventional equipment rack lineups where feasible. For equipment requiring special technical considerations, Adelphia must provide the equipment layout, including spatial dimensions for such equipment pursuant to generic requirements contained in Telcordia GR-63-Core, and shall be responsible for compliance with all special technical requirements associated with such equipment pursuant.
- 3.2 Caged. At Adelphia's expense, Adelphia may arrange with a Supplier certified by BellSouth ("Certified Supplier") to construct a collocation arrangement enclosure, where technically feasible as that term has been defined by the FCC, in accordance with BellSouth's guidelines and specifications prior to starting equipment installation. BellSouth will provide guidelines and specifications upon request. Adelphia's Certified Supplier shall be responsible for filing and receiving any and all necessary permits and/or licenses for such construction. BellSouth shall cooperate with Adelphia and provide, at Adelphia's expense, the documentation, including existing building architectural drawings, enclosure drawings, and specifications required and necessary for Adelphia to obtain the zoning, permits and/or other licenses. Adelphia's Certified Supplier shall bill Adelphia directly for all work performed for Adelphia pursuant to this Attachment and BellSouth shall have no liability for nor responsibility to pay such charges imposed by Adelphia's Certified Supplier. Adelphia must provide the local BellSouth Remote Site Location contact with two Access Keys used to enter the locked enclosure. Except in case of emergency, BellSouth will not access Adelphia's locked enclosure prior to notifying Adelphia. Upon request, BellSouth shall construct the enclosure for Adelphia.
- 3.2.1 BellSouth may elect to review Adelphia's plans and specifications prior to allowing construction to start to ensure compliance with BellSouth's guidelines and specifications. Notification to Adelphia indicating BellSouth's desire to execute this review will be provided in BellSouth's response to the Initial Application, if Adelphia has indicated their desire to construct their own enclosure. If Adelphia's Initial Application does not indicate their desire to construct their own enclosure, but their subsequent firm order does indicate their desire to construct their own enclosure, then notification to review will be given within ten (10) calendar days after the Firm Order date. BellSouth shall complete its review within fifteen (15) calendar days after the receipt of the plans and specifications. Regardless of whether or not BellSouth elects to review Adelphia's plans and specifications, BellSouth reserves the right to inspect the enclosure after construction to make sure it is constructed according to the

submitted plans and specifications and/or BellSouth's guidelines and specifications, as applicable. BellSouth shall require Adelphia to remove or correct within seven (7) calendar days at Adelphia's expense any structure that does not meet these plans and specifications or, where applicable, BellSouth guidelines and specifications.

- 3.3 Shared Collocation. Adelphia may allow other telecommunications carriers to share Adelphia's Remote Collocation Space pursuant to terms and conditions agreed to by Adelphia ("Host") and other telecommunications carriers ("Guests") and pursuant to this Section, except where the BellSouth Remote Site Location is located within a leased space and BellSouth is prohibited by said lease from offering such an option or is located on property for which BellSouth holds an easement and such easement does not permit such an option. Adelphia shall notify BellSouth in writing upon execution of any agreement between the Host and its Guest within ten (10) calendar days of its execution and prior to any Firm Order. Further, such notice shall include the name of the Guest(s) and the term of the agreement, and shall contain a certification by Adelphia that said agreement imposes upon the Guest(s) the same terms and conditions for Remote Collocation Space as set forth in this Attachment between BellSouth and Adelphia.
- 3.3.1 Adelphia, as the Host, shall be the sole interface and responsible Party to BellSouth for assessment of rates and charges contained within this Attachment and for the purposes of ensuring that the safety and security requirements of this Attachment are fully complied with by the Guest, its employees and agents. BellSouth shall provide Adelphia with a proration of the costs of the Remote Collocation Space based on the number of collocators and the space used by each with a minimum charge of one (1) bay/rack per Host/Guest. In those instances where the Host permits a Guest to use a shelf within the Host's bay, BellSouth will not prorate the cost of the bay. In all states other than Florida, and in addition to the foregoing, Adelphia shall be the responsible party to BellSouth for the purpose of submitting applications for initial and additional equipment placement of Guest. A separate Guest application shall require the assessment of an Initial or Subsequent Application Fee, as set forth in Exhibit B, which will be charged to the Host. BellSouth shall bill this non-recurring fee on the date that BellSouth provides it written response ("Application Response").
- 3.3.2 Notwithstanding the foregoing, the Guest may arrange directly with BellSouth for the provision of the interconnecting facilities between BellSouth and the Guest and for the provision of the services and access to unbundled network elements. The bill for these interconnecting facilities, services and access to UNEs will be charged to the Guest pursuant to the applicable tariff or the Guest's Interconnection Agreement with BellSouth.
- 3.3.3 Adelphia shall indemnify and hold harmless BellSouth from any and all claims, actions, causes of action, of whatever kind or nature arising out of the presence of Adelphia's Guests in the Remote Collocation Space except to the extent caused by BellSouth's sole negligence, gross negligence, or willful misconduct.

- 3.4 Adjacent Collocation. Subject to technical feasibility and space availability, BellSouth will permit adjacent Remote Site collocation arrangements (“Remote Site Adjacent Arrangement”) on the property on which the Remote Site is located, where the Remote Site Adjacent Arrangement does not interfere with access to existing or planned structures or facilities on the Remote Site Location property. The Remote Site Adjacent Arrangement shall be constructed or procured by Adelphia and in conformance with BellSouth’s design and construction specifications. Further, Adelphia shall construct, procure, maintain and operate said Remote Site Adjacent Arrangement(s) pursuant to all of the terms and conditions set forth in this Attachment. Rates shall be negotiated at the time of the application for the Remote Site Adjacent Arrangement.
- 3.4.1 Should Adelphia elect Adjacent Collocation, Adelphia must arrange with a Certified Supplier to construct a Remote Site Adjacent Arrangement structure in accordance with BellSouth’s guidelines and specifications. Where local building codes require enclosure specifications more stringent than BellSouth’s standard specification, Adelphia and Adelphia’s Certified Supplier must comply with local building code requirements. Adelphia’s Certified Supplier shall be responsible for filing and receiving any and all necessary zoning, permits and/or licenses for such construction. Adelphia’s Certified Supplier shall bill Adelphia directly for all work performed for Adelphia pursuant to this Attachment and BellSouth shall have no liability for nor responsibility to pay such charges imposed by Adelphia’s Certified Supplier. Adelphia must provide the local BellSouth Remote Site Location contact with two cards, keys or other access device used to enter the locked enclosure. Except in cases of emergency, BellSouth shall not access Adelphia’s locked enclosure prior to notifying Adelphia.
- 3.4.2 Adelphia must submit its plans and specifications to BellSouth with its Firm Order. BellSouth shall review Adelphia’s plans and specifications prior to construction of a Remote Site Adjacent Arrangement(s) to ensure compliance with BellSouth’s guidelines and specifications. BellSouth shall complete its review within fifteen (15) calendar days after receipt of plans and specifications. BellSouth may inspect the Remote Site Adjacent Arrangement(s) during and after construction to confirm it is constructed according to the submitted plans and specifications. BellSouth shall require Adelphia to remove or correct within seven (7) calendar days at Adelphia’s expense any structure that does not meet these plans and specifications.
- 3.4.3 Adelphia shall provide a concrete pad, the structure housing the arrangement, heating/ventilation/air conditioning (“HVAC”), lighting, and all facilities that connect the structure (i.e. racking, conduits, etc.) to the BellSouth point of demarcation. At Adelphia’s option, and where the local authority having jurisdiction permits, BellSouth shall provide an AC power source and access to physical collocation services and facilities subject to the same nondiscriminatory requirements as applicable to any other physical collocation arrangement. Adelphia’s Certified Supplier shall be responsible, at

- Adelphia's expense, for filing and receiving any and all necessary zoning, permits and/or licenses for such arrangement. BellSouth shall allow Shared Collocation within a Remote Site Adjacent Arrangement pursuant to the terms and conditions set forth herein.
- 3.5 Co-carrier cross-connect (CCXC). The primary purpose of collocation is for a collocated telecommunications carrier to interconnect with BellSouth's network or to access BellSouth's unbundled network elements for the provision of telecommunications services within a BellSouth Premises. BellSouth will permit Adelphia to interconnect between its virtual or physical collocation arrangements and those of another collocated telecommunications carrier within the same remote site premises. Both Adelphia's agreement and the other collocated telecommunications carrier's agreement must contain rates, terms and conditions for CCXC language. At no point in time shall Adelphia use the Remote Collocation Space for the sole or primary purpose of cross connecting to other collocated telecommunications carriers.
- 3.5.1 Adelphia must use a BellSouth Certified Supplier to place the CCXC. The CCXC shall be provisioned through facilities owned by Adelphia. Such connections to other carriers may be made using either optical or electrical facilities. In cases where Adelphia's equipment and the equipment of the other interconnector are located in contiguous caged Collocation Spaces, Adelphia will have the option of using Adelphia's own technicians to deploy co-carrier cross connects using either electrical or optical facilities between the sets of equipment and construct its own dedicated cable support structure. Adelphia may deploy such optical or electrical connections directly between its own facilities and the facilities of other collocated telecommunications carriers without being routed through BellSouth equipment. Adelphia may not self-provision CCXC on any BellSouth distribution frame, POT (Point of Termination) Bay, DSX (Digital System Cross-connect) or LGX (Light Guide Cross-connect). Adelphia is responsible for ensuring the integrity of the signal.
- 3.5.2 Adelphia shall be responsible for providing written authorization to BellSouth from the other collocated telecommunications carrier prior to installing the CCXC. Adelphia-provisioned CCXC shall utilize common cable support structure. There will be a recurring charge per linear foot, per cable, of common cable support structure used. In the case of two contiguous caged collocation arrangements, Adelphia will have the option of using Adelphia's own technicians to construct its own dedicated support structure.
- 3.5.3 To order CCXCs Adelphia must submit an Initial Application or Subsequent Application. If no modification to the Remote Collocation Space is requested other than the placement of CCXCs, the Subsequent Application Fee for CCXC, as defined in Exhibit B, will apply. If modifications in addition to the placement of CCXCs are requested, the Initial Application or Subsequent Application Fee will apply. This non-recurring fee will be billed by BellSouth on the date that BellSouth provides an Application Response.

4. **Occupancy**

4.1 **Occupancy.** BellSouth will notify Adelphia in writing that the Remote Collocation Space is ready for occupancy ("Space Ready Date"). Adelphia will schedule and complete an acceptance walk-through of each Remote Collocation Space with BellSouth within fifteen (15) calendar days of BellSouth's notifying Adelphia that Remote Collocation Space is ready for occupancy ("Space Ready Date"). . BellSouth will correct any deviations to Adelphia's original or jointly amended requirements within seven (7) calendar days after the walk-through, unless the Parties jointly agree upon a different time frame, and BellSouth shall establish a new Space Ready Date. Another acceptance walk-through will then be scheduled and conducted within fifteen (15) calendar days of the new Space Ready Date. This follow-up acceptance walk-through will be limited to those items identified in the initial walk-through. If Adelphia has met the fifteen (15) calendar day interval(s), billing will begin upon the date of Adelphia's acceptance of the Collocation Space ("Space Acceptance Date"). In the event that Adelphia fails to complete an acceptance walk-through within this fifteen (15) calendar day interval, the Remote Collocation Space shall be deemed accepted by Adelphia. Billing will commence on the Space Ready Date or on the Space Acceptance Date, whichever is sooner. Adelphia must notify BellSouth in writing that collocation equipment installation is complete and is operational with BellSouth's network. BellSouth may, at its option, not accept orders for cross connects until receipt of such notice. For purposes of this paragraph, Adelphia's telecommunications equipment will be deemed operational when cross-connected to BellSouth's network for the purpose of service provision.

4.2 **Termination of Occupancy.** In addition to any other provisions addressing termination of occupancy in this Attachment, Adelphia may terminate occupancy in a particular Remote Collocation Space by submitting a Subsequent Application requesting termination of occupancy. A Subsequent Application Fee will not apply for termination of occupancy. BellSouth may terminate Adelphia's right to occupy the Remote Collocation Space in the event Adelphia fails to comply with any provision of this Agreement.

4.2.1 Upon termination of occupancy, Adelphia at its expense shall remove its equipment and other property from the Remote Collocation Space. Adelphia shall have thirty (30) calendar days from the termination date to complete such removal, including the removal of all equipment and facilities of Adelphia's Guests, unless Adelphia's Guest has assumed responsibility for the Remote Collocation Space housing the Guest's equipment and executed the documentation required by BellSouth prior to such removal date. Adelphia shall continue payment of monthly fees to BellSouth until such date as Adelphia, and if applicable Adelphia's Guest, has fully vacated the Remote Collocation Space and the Space Relinquish Form has been accepted by BellSouth. Should Adelphia or Adelphia's Guest fail to vacate the Remote Collocation Space within thirty (30) calendar days from the termination date, BellSouth shall have the right to remove the equipment and dispose of the equipment and other property of

Adelphia or Adelphia's Guest, in any manner that BellSouth deems fit, at Adelphia's expense and with no liability whatsoever for Adelphia or Adelphia's Guest's property. Upon termination of Adelphia's right to occupy Remote Collocation Space, the Remote Collocation Space will revert back to BellSouth, and Adelphia shall surrender such Remote Collocation Space to BellSouth in the same condition as when first occupied by the Adelphia except for ordinary wear and tear unless otherwise agreed to by the Parties. For CEVs and huts Adelphia's BellSouth Certified Supplier shall be responsible for updating and making any necessary changes to BellSouth's records as required by BellSouth's guidelines and specifications including but not limited to Record Drawings and ERMA Records. Adelphia shall be responsible for the cost of removing any Adelphia constructed enclosure, together with all support structures (e.g., racking, conduits, power cables, etc.), at the termination of occupancy and restoring the grounds to their original condition.

5. Use of Remote Collocation Space

5.1 Equipment Type. BellSouth permits the collocation of any type of equipment necessary for interconnection to BellSouth's network or for access to BellSouth's unbundled network elements in the provision of telecommunications services, as the term "necessary" is defined by FCC 47 C.F.R. Section 51.323 (b). The primary purpose and function of any equipment collocated in a Remote Collocated Space must be for interconnection to BellSouth's network or for access to BellSouth's unbundled network elements in the provision of telecommunications services.

5.1.1 Examples of equipment that would not be considered necessary include but are not limited to: Traditional circuit switching equipment, equipment used exclusively for call-related databases, computer servers used exclusively for providing information services, operations support system (OSS) equipment used to support collocated telecommunications carrier network operations, equipment that generates customer orders, manages trouble tickets or inventory, or stores customer records in centralized databases, etc. BellSouth will determine upon receipt of an application if the requested equipment is necessary based on the criteria established by the FCC. Multifunctional equipment placed on BellSouth's Premises must not place any greater relative burden on BellSouth's property than comparable single-function equipment. BellSouth reserves the right to permit collocation of any equipment on a nondiscriminatory basis.

5.1.2 Such equipment must, at a minimum, meet the following Telcordia Network Equipment Building Systems (NEBS) General Equipment Requirements: Criteria Level 3 requirements as outlined in the Telcordia Special Report SR-3580, Issue 1; equipment design spatial requirements per GR-63-CORE, Section 2; thermal heat dissipation per GR-063-CORE, Section 4, Criteria 77-79; acoustic noise per GR-063-CORE, Section 4, Criterion 128, and National Electric Code standards. Except where otherwise required by a Commission, BellSouth shall comply with the applicable FCC rules relating to denial of collocation based on Adelphia's failure to comply with this Section.

- 5.1.2.1 All Adelphia equipment installation shall comply with BellSouth TR 73503-11h, "Grounding - Engineering Procedures". Metallic cable sheaths and metallic strength members of optical fiber cables as well as the metallic cable sheaths of all copper conductor cables shall be bonded to the designated grounding bus for the Remote Site Location. All copper conductor pairs, working and non-working, shall be equipped with a solid-state protector unit (over-voltage protection only) which has been listed by a nationally recognized testing laboratory.
- 5.1.3 Adelphia shall identify to BellSouth whenever Adelphia submits a Method of Procedure ("MOP") adding equipment to Adelphia's Remote Collocation Space all UCC-1 lien holders or other entities that have a financial interest, secured or otherwise, in the equipment in Adelphia's Remote Collocation Space.
- 5.2 Adelphia shall not use the Remote Collocation Space for marketing purposes nor shall it place any identifying signs or markings in the area surrounding the Remote Collocation Space or on the grounds of the Remote Site Location.
- 5.3 Adelphia shall place a plaque or other identification affixed to Adelphia's equipment to identify Adelphia's equipment, including a list of emergency contacts with telephone numbers.
- 5.4 Entrance Facilities. Adelphia may elect to place Adelphia-owned or Adelphia-leased fiber entrance facilities into the Remote Collocation Space. BellSouth will designate the point of interconnection at the Remote Site Location housing the Remote Collocation Space, which is physically accessible by both Parties. Adelphia will provide and place copper cable through conduit from the Remote Collocation Space to the Feeder Distribution Interface to the splice location of sufficient length for splicing by BellSouth. Adelphia must contact BellSouth for instructions prior to placing the entrance facility cable. Adelphia is responsible for maintenance of the entrance facilities.
- 5.4.1 Shared Use. Adelphia may utilize spare capacity on an existing interconnector entrance facility for the purpose of providing an entrance facility to Adelphia's collocation arrangement within the same BellSouth Remote Site Location. BellSouth shall allow splicing to the entrance facility, provided that the fiber is non-working fiber. The rates set forth in Exhibit B will apply. If Adelphia desires to allow another telecommunications carrier to use its entrance facilities, additional rates, terms and conditions will apply and shall be negotiated between the Parties.
- 5.5 Demarcation Point. BellSouth will designate the point(s) of demarcation between Adelphia's equipment and/or network and BellSouth's network. Each Party will be responsible for maintenance and operation of all equipment/facilities on its side of the demarcation point. Adelphia or its agent must perform all required maintenance to

Adelphia equipment/facilities on its side of the demarcation point, pursuant to Section 5.6, following.

- 5.6 Adelphia's Equipment and Facilities. Adelphia, or if required by this Attachment, Adelphia's Certified Supplier, is solely responsible for the design, engineering, installation, testing, provisioning, performance, monitoring, maintenance and repair of the equipment and facilities used by Adelphia which must be performed in compliance with all applicable BellSouth policies and guidelines. Such equipment and facilities may include but are not limited to cable(s), equipment, and point of termination connections. Adelphia and its selected Certified Supplier must follow and comply with all BellSouth requirements outlined in BellSouth's TR 73503, TR 73519, TR 73572, and TR 73564.
- 5.7 BellSouth's Access to Remote Collocation Space. From time to time BellSouth may require access to the Remote Collocation Space. BellSouth retains the right to access the Remote Collocation Space for the purpose of making BellSouth equipment and Remote Site Location modifications.
- 5.8 Access. Pursuant to Section 12, Adelphia shall have access to the Remote Collocation Space twenty-four (24) hours a day, seven (7) days a week. Adelphia agrees to provide the name and social security number or date of birth or driver's license number of each employee, supplier, or agents of Adelphia or Adelphia's Guests provided with access keys or devices ("Access Keys") prior to the issuance of said Access Keys. Key acknowledgement forms must be signed by Adelphia and returned to BellSouth Access Management within fifteen (15) calendar days of Adelphia's receipt. Failure to return properly acknowledged forms will result in the holding of subsequent requests until acknowledgements are current. Access Keys shall not be duplicated under any circumstances. Adelphia agrees to be responsible for all Access Keys and for the return of all said Access Keys in the possession of Adelphia's employees, suppliers, Guests, or agents after termination of the employment relationship, contractual obligation with Adelphia or upon the termination of this Attachment or the termination of occupancy of an individual Remote Site collocation arrangement.
- 5.8.1 BellSouth will permit one accompanied site visit to Adelphia's designated collocation arrangement location after receipt of the Bona Fide Firm Order (BFFO) without charge to Adelphia. Adelphia must submit to BellSouth the completed Access Control Request Form for all employees or agents requiring access to the BellSouth Remote Site Location a minimum of thirty (30) calendar days prior to the date Adelphia desires access to the Remote Collocation Space. In order to permit reasonable access during construction of the Remote Collocation Space, Adelphia may submit such a request at any time subsequent to BellSouth's receipt of the BFFO. In the event Adelphia desires access to the Remote Collocation Space after submitting such a request but prior to access being approved, in addition to the first accompanied free visit, BellSouth shall permit Adelphia to access the Remote Collocation Space accompanied by a security

- escort at Adelphia's expense. Adelphia must request escorted access at least three (3) business days prior to the date such access is desired.
- 5.9 Lost or Stolen Access Keys. Adelphia shall notify BellSouth in writing immediately in the case of lost or stolen Access Keys. Should it become necessary for BellSouth to re-key Remote Site Locations or deactivate a card as a result of a lost Access Key(s) or for failure to return an Access Key(s), Adelphia shall pay for all reasonable costs associated with the re-keying or deactivating the card.
- 5.10 Interference or Impairment. Notwithstanding any other provisions of this Attachment, Adelphia shall not use any product or service provided under this Agreement, any other service related thereto or used in combination therewith, or place or use any equipment and facilities in any manner that 1) significantly degrades, interferes with or impairs service provided by BellSouth or by any other entity or any person's use of its telecommunications service; 2) endangers or damages the equipment, facilities or other property of BellSouth or of any other entity or person; 3) compromises the privacy of any communications; or 4) creates an unreasonable risk of injury or death to any individual or to the public. If BellSouth reasonably determines that any equipment or facilities of Adelphia violates the provisions of this paragraph, BellSouth shall give written notice to Adelphia, which notice shall direct Adelphia to cure the violation within forty-eight (48) hours of Adelphia's actual receipt of written notice or, at a minimum, to commence curative measures within 24 hours and to exercise reasonable diligence to complete such measures as soon as possible thereafter. After receipt of the notice, the Parties agree to consult immediately and, if necessary, to inspect the arrangement.
- 5.10.1 Except in the case of the deployment of an advanced service which significantly degrades the performance of other advanced services or traditional voice band services, if Adelphia fails to take curative action within 48 hours or if the violation is of a character which poses an immediate and substantial threat of damage to property, injury or death to any person, or any other significant degradation, interference or impairment of BellSouth's or any other entity's service, then and only in that event BellSouth may take such action as it deems appropriate to correct the violation, including without limitation the interruption of electrical power to Adelphia's equipment. BellSouth will endeavor, but is not required, to provide notice to Adelphia prior to taking such action and shall have no liability to Adelphia for any damages arising from such action, except to the extent that such action by BellSouth constitutes willful misconduct.
- 5.10.2 For purposes of this section, the term significantly degrade shall mean an action that noticeably impairs a service from a user's perspective. In the case of the deployment of an advanced service which significantly degrades the performance of other advanced services or traditional voice band services and Adelphia fails to take curative action within 48 hours then BellSouth will establish before the Commission that the technology deployment is causing the significant degradation. Any claims of network

harm presented to Adelphia or, if subsequently necessary, the Commission must be supported with specific and verifiable information. Where BellSouth demonstrates that a deployed technology is significantly degrading the performance of other advanced services or traditional voice band services, Adelphia shall discontinue deployment of that technology and migrate its customers to technologies that will not significantly degrade the performance of other such services. Where the only degraded service itself is a known disturber, and the newly deployed technology satisfies at least one of the criteria for a presumption that is acceptable for deployment under Section 47 C.F.R. 51.230, the degraded service shall not prevail against the newly deployed technology.

5.11 Personalty and its Removal. Facilities and equipment placed by Adelphia in the Remote Collocation Space shall not become a part of the Remote Site Location, even if nailed, screwed or otherwise fastened to the Remote Collocation Space but shall retain their status as personalty and may be removed by Adelphia at any time. Any damage caused to the Remote Collocation Space by Adelphia's employees, agents or representatives shall be promptly repaired by Adelphia at its expense.

5.11.1 If Adelphia decides to remove equipment from its Remote Collocation Space and the removal requires no physical changes, BellSouth will bill Adelphia an Administrative Only Application Fee as set forth in Exhibit B for these changes. This non-recurring fee will be billed on the date that BellSouth provides an Application Response.

5.12 Alterations. In no case shall Adelphia or any person acting on behalf of Adelphia make any rearrangement, modification, improvement, addition, or other alteration which could affect in any way space, power, HVAC, and/or safety considerations to the Remote Collocation Space or the BellSouth Remote Site Location without the written consent of BellSouth, which consent shall not be unreasonably withheld. The cost of any specialized alterations shall be paid by Adelphia. Any such material rearrangement, modification, improvement, addition, or other alteration shall require an application and Application Fee. BellSouth will bill the non-recurring fee on the date that BellSouth provides an Application Response.

5.13 Upkeep of Remote Collocation Space. Adelphia shall be responsible for the general upkeep and cleaning of the Remote Collocation Space. Adelphia shall be responsible for removing any Adelphia debris from the Remote Collocation Space and from in and around the Remote Collocation Site on each visit.

6. Ordering and Preparation of Remote Collocation Space

6.1 Should any state or federal regulatory agency impose procedures or intervals applicable to Adelphia and BellSouth that are different from procedures or intervals set forth in this Section, whether now in effect or that become effective after execution of this Agreement, those procedures or intervals shall supersede the requirements set forth herein for that jurisdiction for all applications submitted for the first time after the effective date thereof

- 6.2 Initial Application. For Adelphia or Adelphia's Guest(s) initial equipment placement, Adelphia shall submit to BellSouth a Physical Expanded Interconnection Application Document ("Initial Application"). The application is Bona Fide when it is complete and accurate, meaning that all required fields on the application are completed with the appropriate type of information. An application fee will apply which will be billed on the date that BellSouth provides an Application Response.
- 6.3 Subsequent Application In the event Adelphia or Adelphia's Guest(s) desires to modify the use of the Remote Collocation Space after a BFFO, Adelphia shall complete an application detailing all information regarding the modification to the Remote Collocation Space ("Subsequent Application"). BellSouth shall determine what modifications, if any, to the Remote Site Location are required to accommodate the change requested by Adelphia in the application. Such necessary modifications to the Remote Site Location may include, but are not limited to floor loading changes, changes necessary to meet HVAC requirements, changes to power plant requirements, equipment additions, etc.
- 6.3.1 Application Fee for Subsequent Application. The application fee paid by Adelphia for its request to modify the use of the Collocation Space shall be a full Application Fee as set forth in Exhibit B. The Subsequent Application is Bona Fide when it is complete and accurate, meaning that all required fields on the application are completed with the appropriate type of information. BellSouth will bill the non-recurring fee on the date that BellSouth provides an Application Response.
- 6.4 Availability of Space. Upon submission of an application, BellSouth will permit Adelphia to physically collocate, pursuant to the terms of this Attachment, at any BellSouth Remote Site Location, unless BellSouth has determined that there is no space available due to space limitations or that Remote Site Collocation is not practical for technical reasons. In the event space is not immediately available at a Remote Site Location, BellSouth reserves the right to make additional space available, in which case the conditions in Section 7 shall apply, or BellSouth may elect to deny space in accordance with this Section in which case virtual or adjacent collocation options may be available. If the amount of space requested is not available, BellSouth will notify Adelphia of the amount that is available.
- 6.5 Space Availability Notification.
- 6.5.1 Unless otherwise specified, BellSouth will respond to an application within ten (10) calendar days as to whether space is available or not available within a BellSouth Remote Site Location. BellSouth will also respond as to whether the application is Bona Fide and if it is not Bona Fide the items necessary to cause the application to become Bona Fide. If the amount of space requested is not available, BellSouth will notify Adelphia of the amount of space that is available and no Application Fee shall apply. When BellSouth's response includes an amount of space less than that

- requested by Adelphia or differently configured, Adelphia must resubmit its application to reflect the actual space available.
- 6.6 Denial of Application. If BellSouth notifies Adelphia that no space is available (“Denial of Application”), BellSouth will not assess an Application Fee. After notifying Adelphia that BellSouth has no available space in the requested Remote Site Location, BellSouth will allow Adelphia, upon request, to tour the Remote Site Location within ten (10) calendar days of such Denial of Application. In order to schedule said tour within ten (10) calendar days, the request for a tour of the Remote Site Location must be received by BellSouth within five (5) calendar days of the Denial of Application.
- 6.7 Filing of Petition for Waiver. Upon Denial of Application BellSouth will timely file a petition with the Commission pursuant to 47 U.S.C. § 251(c)(6). BellSouth shall provide to the Commission any information requested by that Commission. Such information shall include which space, if any, BellSouth or any of BellSouth’s affiliates have reserved for future use and a detailed description of the specific future uses for which the space has been reserved. Subject to an appropriate nondisclosure agreement or provision, BellSouth shall permit Adelphia to inspect any plans or diagrams that BellSouth provides to the Commission.
- 6.8 Waiting List. On a first-come, first-served basis governed by the date of receipt of an application or Letter of Intent, BellSouth will maintain a waiting list of requesting carriers who have either received a Denial of Application or, where it is publicly known that the Remote Site Location is out of space, have submitted a Letter of Intent to collocate. BellSouth will notify the telecommunications carriers on the waiting list that can be accommodated by the amount of space that becomes available according to the position of the telecommunications carriers on said waiting list.
- 6.8.1 When space becomes available, Adelphia must submit an updated, complete, and correct application to BellSouth within thirty (30) calendar days of such notification. If Adelphia has originally requested caged Remote Collocation Space and cageless Remote Collocation Space becomes available, Adelphia may refuse such space and notify BellSouth in writing within that time that Adelphia wants to maintain its place on the waiting list without accepting such space. Adelphia may accept an amount of space less than its original request by submitting an application as set forth above, and upon request, may maintain its position on the waiting list for the remaining space that was initially requested. If Adelphia does not submit such an application or notify BellSouth in writing as described above, BellSouth will offer such space to the next telecommunications carrier on the waiting list and remove Adelphia from the waiting list. Upon request, BellSouth will advise Adelphia as to its position on the list.
- 6.9 Public Notification. BellSouth will maintain on its Interconnection Services website a notification document that will indicate all Remote Site Locations that are without

- available space. BellSouth shall update such document within ten (10) calendar days of the date that BellSouth becomes aware that there is insufficient space to accommodate Remote Site Collocation. BellSouth will also post a document on its Interconnection Services website that contains a general notice where space has become available in a Remote Site Location previously on the space exhaust list.
- 6.10 Application Response.
- 6.10.1 In Kentucky, when space has been determined to be available, BellSouth will provide an Application Response within twenty (20) calendar days of receipt of a Bona Fide application. The Application Response will include, at a minimum, the configuration of the space, the Cable Installation Fee, Cable Records Fee, and the space preparation fees, as described in Section 8.
- 6.11 Application Modifications.
- 6.11.1 If a modification or revision is made to any information in the Bona Fide application prior to a BFFO, with the exception of modifications to Customer Information, Contact Information or Billing Contact Information, either at the request of Adelphia or necessitated by technical considerations, said application shall be considered a new application and shall be handled as a new application with respect to response and provisioning intervals and BellSouth will charge Adelphia a full application fee as set forth in Exhibit B. BellSouth will bill the non-recurring fee on the date that BellSouth provides an Application Response.
- 6.12 Bona Fide Firm Order.
- 6.12.1 Adelphia shall indicate its intent to proceed with equipment installation in a BellSouth Remote Site Location by submitting a Firm Order to BellSouth. The BFFO must be received by BellSouth no later than thirty (30) calendar days after BellSouth's Application Response to Adelphia's Bona Fide application or the application will expire.
- 6.12.2 BellSouth will establish a firm order date based upon the date BellSouth is in receipt of a BFFO. BellSouth will acknowledge the receipt of Adelphia's BFFO within seven (7) calendar days of receipt indicating that the BFFO has been received. A BellSouth response to a BFFO will include a Firm Order Confirmation containing the firm order date. No revisions will be made to a BFFO.
- 7. Construction and Provisioning**
- 7.1 Construction and Provisioning Intervals.
- 7.1.1 In Kentucky, BellSouth will complete construction for collocation arrangements under ordinary conditions as soon as possible and within a maximum of sixty (60) calendar

- days from receipt of a BFFO or as agreed to by the Parties. The Parties may mutually agree to renegotiate an alternative provisioning interval or BellSouth may seek a waiver from this interval from the Commission.
- 7.2 In the event BellSouth does not have space immediately available at a Remote Site Location, BellSouth may elect to make additional space available by, for example but not limited to, rearranging BellSouth facilities or constructing additional capacity. In such cases, the above intervals shall not apply and BellSouth will provision the Remote Collocation Space in a nondiscriminatory manner and at parity with BellSouth and will provide Adelphia with the estimated completion date in its Response.
- 7.3 Joint Planning. Joint planning between BellSouth and Adelphia will commence within a maximum of twenty (20) calendar days from BellSouth's receipt of a BFFO. BellSouth will provide the preliminary design of the Remote Collocation Space and the equipment configuration requirements as reflected in the Bona Fide application and affirmed in the BFFO. The Remote Collocation Space completion time period will be provided to Adelphia during joint planning.
- 7.4 Permits. Each Party or its agents will diligently pursue filing for the permits required for the scope of work to be performed by that Party or its agents within ten (10) calendar days of the completion of finalized construction designs and specifications.
- 7.5 Acceptance Walk-through. Adelphia will schedule and complete an acceptance walk-through of each Remote Collocation Space with BellSouth within fifteen (15) calendar days of BellSouth's notifying Adelphia that the Remote Collocation Space is ready for occupancy ("Space Ready Date"). In the event that Adelphia fails to complete an acceptance walk-through within this fifteen (15) calendar day interval, the Remote Collocation Space shall be deemed accepted by Adelphia. BellSouth will correct any deviations to Adelphia's original or jointly amended requirements within seven (7) calendar days after the walk-through, unless the Parties jointly agree upon a different time frame.
- 7.6 Use of BellSouth Certified Supplier. Adelphia shall select a supplier which has been approved by BellSouth to perform all engineering and installation work. Adelphia and Adelphia's BellSouth Certified Supplier must follow and comply with all BellSouth requirements outlined in BellSouth's TR 73503, TR 73519, TR 73572, and TR 73564. In some cases, Adelphia must select separate BellSouth Certified Suppliers for transmission equipment, switching equipment and power equipment. BellSouth shall provide Adelphia with a list of BellSouth Certified Suppliers upon request. The BellSouth Certified Supplier(s) shall be responsible for installing Adelphia's equipment and components, extending power cabling to the BellSouth power distribution frame, performing operational tests after installation is complete, and notifying BellSouth's Outside Plant engineers and Adelphia upon successful completion of installation. The BellSouth Certified Supplier shall bill Adelphia directly for all work performed for

- Adelphia pursuant to this Attachment, and BellSouth shall have no liability for nor responsibility to pay such charges imposed by the BellSouth Certified Supplier. BellSouth shall make available its supplier certification program to Adelphia or any supplier proposed by Adelphia and will not unreasonably withhold certification. All work performed by or for Adelphia shall conform to generally accepted industry guidelines and standards.
- 7.7 Alarm and Monitoring. BellSouth may place alarms in the Remote Site Location for the protection of BellSouth equipment and facilities. Adelphia shall be responsible for placement, monitoring and removal of environmental and equipment alarms used to service Adelphia's Remote Collocation Space. Upon request, BellSouth will provide Adelphia with applicable tariffed service(s) to facilitate remote monitoring of collocated equipment by Adelphia. Both Parties shall use best efforts to notify the other of any verified hazardous conditions known to that Party.
- 7.8 Virtual Remote Site Collocation Relocation. In the event physical Remote Collocation Space was previously denied at a Remote Site Location due to technical reasons or space limitations, and physical Remote Collocation Space has subsequently become available, Adelphia may relocate its virtual Remote Site collocation arrangements to physical Remote Site collocation arrangements and pay the appropriate fees for physical Remote Site collocation and for the rearrangement or reconfiguration of services terminated in the virtual Remote Site collocation arrangement, as outlined in the appropriate BellSouth tariffs. In the event that BellSouth knows when additional space for physical Remote Site collocation may become available at the location requested by Adelphia, such information will be provided to Adelphia in BellSouth's written denial of physical Remote Site collocation. To the extent that (i) physical Remote Collocation Space becomes available to Adelphia within one hundred eighty 180 calendar days of BellSouth's written denial of Adelphia's request for physical collocation, (ii) BellSouth had knowledge that the space was going to become available, and (iii) Adelphia was not informed in the written denial that physical Remote Collocation Space would become available within such one hundred eighty 180 calendar days, then Adelphia may relocate its virtual Remote Site collocation arrangement to a physical Remote Site collocation arrangement and will receive a credit for any nonrecurring charges previously paid for such virtual Remote Site collocation. Adelphia must arrange with a BellSouth Certified Supplier for the relocation of equipment from its virtual Remote Collocation Space to its physical Remote Collocation Space and will bear the cost of such relocation.
- 7.9 Virtual to Physical Conversion (In-Place). Virtual collocation arrangements may be converted to "in-place" physical arrangements if the potential conversion meets the following four criteria: 1) there is no change in the amount of equipment or the configuration of the equipment that was in the virtual collocation arrangement; 2) the conversion of the virtual collocation arrangement will not cause the equipment or the

results of that conversion to be located in a space that BellSouth has reserved for its own future needs; 3) the converted arrangement does not limit BellSouth's ability to secure its own equipment and facilities due to the location of the virtual collocation arrangement; and 4) any changes to the arrangement can be accommodated by existing power, HVAC, and other requirements. Unless otherwise specified, BellSouth will complete virtual to in-place physical collocation conversions within sixty (60) calendar days from receipt of the BFFO. BellSouth will bill Adelphia an Administrative Only Application Fee as set forth in Exhibit B for these changes on the date that BellSouth provides an Application Response.

7.10 Cancellation. If, at any time prior to space acceptance, Adelphia cancels its order for the Remote Collocation Space(s) ("Cancellation"), BellSouth will bill the applicable non-recurring rate for any and all work processes for which work has begun..

7.11 Licenses. Adelphia, at its own expense, will be solely responsible for obtaining from governmental authorities, and any other appropriate agency, entity, or person, all rights, privileges, and licenses necessary or required to operate as a provider of telecommunications services to the public or to occupy the Remote Collocation Space.

7.12 Environmental Hazard Guidelines. The Parties agree to utilize and adhere to the Environmental Hazard Guidelines identified in Exhibit A attached hereto.

8. Rates and Charges

8.1 Recurring Charges. If Adelphia has met the applicable fifteen (15) calendar day walk-through interval(s) specified in Section 4, billing for recurring charges will begin upon the Space Acceptance Date. In the event that Adelphia fails to complete an acceptance walk-through within the applicable fifteen (15) calendar day interval, billing for recurring charges will commence on the Space Ready Date or on the Space Acceptance Date, whichever is sooner.

8.2 Application Fee. BellSouth shall assess an Application Fee via a service order, which shall be issued at the time BellSouth responds that space is available pursuant to Section 2. Payment of said Application Fee will be due as dictated by Adelphia's current billing cycle and is non-refundable.

8.3 Rack/Bay Space. The rack/bay space charge includes reasonable charges for air conditioning, ventilation and other allocated expenses associated with maintenance of the Remote Site Location, and includes amperage necessary to power Adelphia's equipment. Adelphia shall pay rack/bay space charges based upon the number of racks/bays requested. BellSouth will assign Remote Collocation Space in conventional remote site rack/bay lineups where feasible.

- 8.4 Power. BellSouth shall make available –48 Volt (-48V) DC power for Adelphia's Remote Collocation Space at a BellSouth Power Board or BellSouth Battery Distribution Fuse Bay (BDFB) at Adelphia's option within the Remote Site Location. The charge for power shall be assessed as part of the recurring charge for rack/bay space. If the power requirements for Adelphia's equipment exceeds the capacity available, then such power requirements shall be assessed on an individual case basis.
- 8.4.1 Adjacent Collocation Power. Charges for AC power will be assessed per breaker ampere per month. Rates include the provision of commercial and standby AC power, where available. When obtaining power from a BellSouth service panel, protection devices and power cables must be engineered (sized), and installed by Adelphia's BellSouth Certified Supplier except that BellSouth shall engineer and install protection devices and power cables for Adjacent Collocation. Adelphia's BellSouth Certified Supplier must also provide a copy of the engineering power specification prior to the equipment becoming operational. Charges for AC power shall be assessed pursuant to the rates specified in Exhibit B. AC power voltage and phase ratings shall be determined on a per location basis. At Adelphia's option, Adelphia may arrange for AC power in an Adjacent Collocation arrangement from a retail provider of electrical power.
- 8.5 Security Escort. A security escort will be required whenever Adelphia or its approved agent desires access to the Remote Site Location after the one accompanied site visit allowed pursuant to Section 5 prior to completing BellSouth's Security Training requirements. Rates for a security escort are assessed according to the schedule appended hereto as Exhibit B beginning with the scheduled escort time. BellSouth will wait for one-half (1/2) hour after the scheduled time for such an escort and Adelphia shall pay for such half-hour charges in the event Adelphia fails to show up.
- 8.6 Other. If no rate is identified in the contract, the rate for the specific service or function will be negotiated by the Parties upon request by either Party.

9. Insurance

- 9.1 Adelphia shall, at its sole cost and expense, procure, maintain, and keep in force insurance as specified in this Section and underwritten by insurance companies licensed to do business in the states applicable under this Attachment and having a Best's Insurance Rating of A-.
- 9.2 Adelphia shall maintain the following specific coverage:
- 9.2.1 Commercial General Liability coverage in the amount of ten million dollars (\$10,000,000.00) or a combination of Commercial General Liability and Excess/Umbrella coverage totaling not less than ten million dollars (\$10,000,000.00). BellSouth shall be named as an Additional Insured on the Commercial General Liability policy as specified herein.

- 9.2.2 Statutory Workers Compensation coverage and Employers Liability coverage in the amount of one hundred thousand dollars (\$100,000.00) each accident, one hundred thousand dollars (\$100,000.00) each employee by disease, and five hundred thousand dollars (\$500,000.00) policy limit by disease.
- 9.2.3 All Risk Property coverage on a full replacement cost basis insuring all of Adelphia's real and personal property situated on or within BellSouth's Remote Site Location.
- 9.2.4 Adelphia may elect to purchase business interruption and contingent business interruption insurance, having been advised that BellSouth assumes no liability for loss of profit or revenues should an interruption of service occur.
- 9.3 The limits set forth in Section 9.2 above may be increased by BellSouth from time to time during the term of this Attachment upon thirty (30) calendar days notice to Adelphia to at least such minimum limits as shall then be customary with respect to comparable occupancy of BellSouth structures.
- 9.4 All policies purchased by Adelphia shall be deemed to be primary and not contributing to or in excess of any similar coverage purchased by BellSouth. All insurance must be in effect on or before the date equipment is delivered to BellSouth's Remote Site Location and shall remain in effect for the term of this Attachment or until all of Adelphia's property has been removed from BellSouth's Remote Site Location, whichever period is longer. If Adelphia fails to maintain required coverage, BellSouth may pay the premiums thereon and seek reimbursement of same from Adelphia.
- 9.5 Adelphia shall submit certificates of insurance reflecting the coverage required pursuant to this Section a minimum of ten (10) business days prior to the commencement of any work in the Remote Collocation Space. Failure to meet this interval may result in construction and equipment installation delays. Adelphia shall arrange for BellSouth to receive thirty (30) business days' advance notice of cancellation from Adelphia's insurance company. Adelphia shall forward a certificate of insurance and notice of cancellation/non-renewal to BellSouth at the following address:
- BellSouth Telecommunications, Inc.
Attn.: Risk Management Coordinator
17H53 BellSouth Center
675 W. Peachtree Street
Atlanta, Georgia 30375
- 9.6 Adelphia must conform to recommendations made by BellSouth's fire insurance company to the extent BellSouth has agreed to, or shall hereafter agree to, such recommendations.

- 9.7 **Self-Insurance.** If Adelphia's net worth exceeds five hundred million dollars (\$500,000,000), Adelphia may elect to request self-insurance status in lieu of obtaining any of the insurance required in Sections 9.2.1 and 9.2.2. Adelphia shall provide audited financial statements to BellSouth thirty (30) calendar days prior to the commencement of any work in the Remote Collocation Space. BellSouth shall then review such audited financial statements and respond in writing to Adelphia in the event that self-insurance status is not granted to Adelphia. If BellSouth approves Adelphia for self-insurance, Adelphia shall annually furnish to BellSouth, and keep current, evidence of such net worth that is attested to by one of Adelphia's corporate officers. The ability to self-insure shall continue so long as Adelphia meets all of the requirements of this Section. If Adelphia subsequently no longer satisfies this Section, Adelphia is required to purchase insurance as indicated by Sections 9.2.1 and Section 9.2.2.
- 9.8 The net worth requirements set forth in Section 9.7 may be increased by BellSouth from time to time during the term of this Attachment upon thirty (30) calendar days' notice to Adelphia to at least such minimum limits as shall then be customary with respect to comparable occupancy of BellSouth structures.
- 9.9 Failure to comply with the provisions of this Section will be deemed a material breach of this Attachment.

10. Mechanics Liens

- 10.1 If any mechanics lien or other liens shall be filed against property of either Party (BellSouth or Adelphia), or any improvement thereon by reason of or arising out of any labor or materials furnished or alleged to have been furnished or to be furnished to or for the other Party or by reason of any changes, or additions to said property made at the request or under the direction of the other Party, the other Party directing or requesting those changes shall, within thirty (30) business days after receipt of written notice from the Party against whose property said lien has been filed, either pay such lien or cause the same to be bonded off the affected property in the manner provided by law. The Party causing said lien to be placed against the property of the other shall also defend, at its sole cost and expense, on behalf of the other, any action, suit or proceeding which may be brought for the enforcement of such liens and shall pay any damage and discharge any judgment entered thereon.

11. Inspections

- 11.1 BellSouth may conduct an inspection of Adelphia's equipment and facilities in the Remote Collocation Space(s) prior to the activation of facilities between Adelphia's equipment and equipment of BellSouth. BellSouth may conduct an inspection if Adelphia adds equipment and may otherwise conduct routine inspections at reasonable intervals mutually agreed upon by the Parties. BellSouth shall provide Adelphia with a minimum of forty-eight (48) hours or two (2) business days, whichever is greater,

advance notice of all such inspections. All costs of such inspection shall be borne by BellSouth.

12. Security and Safety Requirements

- 12.1 Unless otherwise specified, Adelphia will be required, at its own expense, to conduct a statewide investigation of criminal history records for each Adelphia employee hired in the past five years being considered for work on the BellSouth Remote Site Location, for the states/counties where the Adelphia employee has worked and lived for the past five years. Where state law does not permit statewide collection or reporting, an investigation of the applicable counties is acceptable. Adelphia shall not be required to perform this investigation if an affiliated company of Adelphia has performed an investigation of the Adelphia employee seeking access, if such investigation meets the criteria set forth above. This requirement will not apply if Adelphia has performed a pre-employment statewide investigation of criminal history records of the Adelphia employee for the states/counties where the Adelphia employee has worked and lived for the past five years or, where state law does not permit a statewide investigation, an investigation of the applicable counties.
- 12.2 Adelphia will be required to administer to their personnel assigned to the BellSouth Premises security training either provided by BellSouth, or meeting criteria defined by BellSouth.
- 12.3 Adelphia shall provide its employees and agents with picture identification, which must be worn, and visible at all times while in the Remote Collocation Space or other areas in or around the Remote Site Location. The photo Identification card shall bear, at a minimum, the employee's name and photo, and Adelphia's name. BellSouth reserves the right to remove from its Remote Site Location any employee of Adelphia not possessing identification issued by Adelphia or who have violated any of BellSouth's policies as outlined in the CLEC Security Training documents. Adelphia shall hold BellSouth harmless for any damages resulting from such removal of its personnel from BellSouth Remote Site Location. Adelphia shall be solely responsible for ensuring that any Guest of Adelphia is in compliance with all subsections of this Section 12.
- 12.4 Adelphia shall not assign to the BellSouth Remote Site Location any personnel with records of felony criminal convictions. Adelphia shall not assign to the BellSouth Remote Site Location any personnel with records of misdemeanor convictions, except for misdemeanor traffic violations, without advising BellSouth of the nature and gravity of the offense(s). BellSouth reserves the right to refuse access to any Adelphia personnel who have been identified to have misdemeanor criminal convictions. Notwithstanding the foregoing, in the event that Adelphia chooses not to advise BellSouth of the nature and gravity of any misdemeanor conviction, Adelphia may, in the alternative, certify to BellSouth that it shall not assign to the BellSouth Remote

- Site Location any personnel with records of misdemeanor convictions (other than misdemeanor traffic violations).
- 12.4.1 Adelphia shall not knowingly assign to the BellSouth Remote Site Location any individual who was a former employee of BellSouth and whose employment with BellSouth was terminated for a criminal offense whether or not BellSouth sought prosecution of the individual for the criminal offense.
- 12.4.2 Adelphia shall not knowingly assign to the BellSouth Remote Site Location any individual who was a former supplier of BellSouth and whose access to a BellSouth Remote Site Location was revoked due to commission of a criminal offense whether or not BellSouth sought prosecution of the individual for the criminal offense.
- 12.5 For each Adelphia employee or agent hired by Adelphia within five years of being considered for work on the BellSouth Remote Site Location, who requires access to a BellSouth Remote Site Location pursuant to this Attachment, Adelphia shall furnish BellSouth, prior to an employee gaining such access, a certification that the aforementioned background check and security training were completed. The certification will contain a statement that no felony convictions were found and certifying that the security training was completed by the employee. If the employee's criminal history includes misdemeanor convictions, Adelphia will disclose the nature of the convictions to BellSouth at that time. In the alternative, Adelphia may certify to BellSouth that it shall not assign to the BellSouth Remote Site Location any personnel with records of misdemeanor convictions other than misdemeanor traffic violations.
- 12.5.1 For all other Adelphia employees requiring access to a BellSouth Remote Site Location pursuant to this Attachment, Adelphia shall furnish BellSouth, prior to an employee gaining such access, a certification that the employee is not subject to the requirements of Section 12.5 above and that security training was completed by the employee.
- 12.6 At BellSouth's request, Adelphia shall promptly remove from BellSouth's Remote Site Location any employee of Adelphia BellSouth does not wish to grant access to its Remote Site Location 1) pursuant to any investigation conducted by BellSouth or 2) prior to the initiation of an investigation if an employee of Adelphia is found interfering with the property or personnel of BellSouth or another collocated telecommunications carrier, provided that an investigation shall promptly be commenced by BellSouth.
- 12.7 Security Violations. BellSouth reserves the right to interview Adelphia's employees, agents, or suppliers in the event of wrongdoing in or around BellSouth's property or involving BellSouth's or another telecommunications carrier's property or personnel, provided that BellSouth shall provide reasonable notice to Adelphia's Security contact of such interview. Adelphia and its suppliers shall reasonably cooperate with BellSouth's investigation into allegations of wrongdoing or criminal conduct committed by, witnessed by, or involving Adelphia's employees, agents, or suppliers.

- Additionally, BellSouth reserves the right to bill Adelphia for all reasonable costs associated with investigations involving its employees, agents, or suppliers if it is established and mutually agreed in good faith that Adelphia's employees, agents, or suppliers are responsible for the alleged act. BellSouth shall bill Adelphia for BellSouth property, which is stolen or damaged where an investigation determines the culpability of Adelphia's employees, agents, or suppliers and where Adelphia agrees, in good faith, with the results of such investigation. Adelphia shall notify BellSouth in writing immediately in the event that the Adelphia discovers one of its employees already working on the BellSouth Remote Site Location is a possible security risk. Upon request of the other Party, the Party who is the employer shall discipline consistent with its employment practices, up to and including removal from BellSouth's Remote Site Location, any employee found to have violated the security and safety requirements of this section. Adelphia shall hold BellSouth harmless for any damages resulting from such removal of its personnel from BellSouth's Remote Site Location.
- 12.8 Use of Supplies. Unauthorized use of telecommunications equipment or supplies by either Party, whether or not used routinely to provide telephone service (e.g. plug-in cards,) will be strictly prohibited and handled appropriately. Costs associated with such unauthorized use may be charged to the offending Party, as may be all associated investigative costs.
- 12.9 Use of Official Lines. Except for non-toll calls necessary in the performance of their work, neither Party shall use the telephones of the other Party on the BellSouth Remote Site Location. Charges for unauthorized telephone calls may be charged to the offending Party, as may be all associated investigative costs.
- 12.10 Accountability. Full compliance with the Security requirements of this Section shall in no way limit the accountability of either Party to the other for the improper actions of its employees.
- 13. Destruction of Remote Collocation Space**
- 13.1 In the event a Remote Collocation Space is wholly or partially damaged by fire, windstorm, tornado, flood or by similar causes to such an extent as to be rendered wholly unsuitable for Adelphia's permitted use hereunder, then either Party may elect within ten (10) calendar days after such damage, to terminate this Attachment with respect to the affected Remote Collocation Space, and if either Party shall so elect, by giving the other written notice of termination, both Parties shall stand released of and from further liability under the terms hereof with respect to such Remote Collocation Space. If the Remote Collocation Space shall suffer only minor damage and shall not be rendered wholly unsuitable for Adelphia's permitted use, or is damaged and the option to terminate is not exercised by either Party, BellSouth covenants and agrees to proceed promptly without expense to Adelphia, except for improvements not the

property of BellSouth, to repair the damage. BellSouth shall have a reasonable time within which to rebuild or make any repairs, and such rebuilding and repairing shall be subject to delays caused by storms, shortages of labor and materials, government regulations, strikes, walkouts, and causes beyond the control of BellSouth, which causes shall not be construed as limiting factors, but as exemplary only. Adelphia may, at its own expense, accelerate the rebuild of its Remote Collocation Space and equipment provided however that a BellSouth Certified Supplier is used and the necessary space preparation has been completed. Rebuild of equipment must be performed by a BellSouth Certified Vendor. If Adelphia's acceleration of the project increases the cost of the project, then those additional charges will be incurred by Adelphia. Where allowed and where practical, Adelphia may erect a temporary facility while BellSouth rebuilds or makes repairs. In all cases where the Remote Collocation Space shall be rebuilt or repaired, Adelphia shall be entitled to an equitable abatement of rent and other charges, depending upon the unsuitability of the Remote Collocation Space for Adelphia's permitted use, until such Remote Collocation Space is fully repaired and restored and Adelphia's equipment installed therein (but in no event later than thirty (30) calendar days after the Remote Collocation Space is fully repaired and restored). Where Adelphia has placed a Remote Site Adjacent Arrangement pursuant to Section 3, Adelphia shall have the sole responsibility to repair or replace said Remote Site Adjacent Arrangement provided herein. Pursuant to this Section, BellSouth will restore the associated services to the Remote Site Adjacent Arrangement.

14. Eminent Domain

- 14.1 If the whole of a Remote Collocation Space or Remote Site Adjacent Arrangement shall be taken by any public authority under the power of eminent domain, then this Attachment shall terminate with respect to such Remote Collocation Space or Remote Site Adjacent Arrangement as of the day possession shall be taken by such public authority and rent and other charges for the Remote Collocation Space or Remote Site Adjacent Arrangement shall be paid up to that day with proportionate refund by BellSouth of such rent and charges as may have been paid in advance for a period subsequent to the date of the taking. If any part of the Remote Collocation Space or Remote Site Adjacent Arrangement shall be taken under eminent domain, BellSouth and Adelphia shall each have the right to terminate this Attachment with respect to such Remote Collocation Space or Remote Site Adjacent Arrangement and declare the same null and void, by written notice of such intention to the other Party within ten (10) calendar days after such taking.

15. Nonexclusivity

- 15.1 Adelphia understands that this Attachment is not exclusive and that BellSouth may enter into similar agreements with other Parties. Assignment of space pursuant to all such agreements shall be determined by space availability and made on a first come, first served basis.

ENVIRONMENTAL AND SAFETY PRINCIPLES

The following principles provide basic guidance on environmental and safety issues when applying for and establishing Physical Collocation arrangements.

1. GENERAL PRINCIPLES

- 1.1 Compliance with Applicable Law. BellSouth and Adelphia agree to comply with applicable federal, state, and local environmental and safety laws and regulations including U.S. Environmental Protection Agency (USEPA) regulations issued under the Clean Air Act (CAA), Clean Water Act (CWA), Resource Conservation and Recovery Act (RCRA), Comprehensive Environmental Response, Compensation and Liability Act (CERCLA), Superfund Amendments and Reauthorization Act (SARA), the Toxic Substances Control Act (TSCA), and OSHA regulations issued under the Occupational Safety and Health Act of 1970, as amended and NFPA and National Electrical Codes (NEC) and the NESC ("Applicable Laws"). Each Party shall notify the other if compliance inspections are conducted by regulatory agencies and/or citations are issued that relate to any aspect of this Attachment.
- 1.2 Notice. BellSouth and Adelphia shall provide notice to the other, including Material Safety Data Sheets (MSDSs), of known and recognized physical hazards or Hazardous Chemicals existing on site or brought on site. A Hazardous Chemical inventory list is posted on an OSHA Poster and updated annually at each Central Office. This Poster is normally located near the front entrance of the building or in the lounge area. Each Party is required to provide specific notice for known potential Imminent Danger conditions. Adelphia should contact 1-800-743-6737 for any BellSouth MSDS required.
- 1.3 Practices/Procedures. BellSouth may make available additional environmental control procedures for Adelphia to follow when working at a BellSouth Remote Site Location (See Section 2, below). These practices/procedures will represent the regular work practices required to be followed by the employees and suppliers of BellSouth for environmental protection. Adelphia will require its suppliers, agents and others accessing the BellSouth Remote Site Location to comply with these practices. Section 2 lists the Environmental categories where BST practices should be followed by Adelphia when operating in the BellSouth Remote Site Location.
- 1.4 Environmental and Safety Inspections. BellSouth reserves the right to inspect the Adelphia space with proper notification. BellSouth reserves the right to stop any Adelphia work operation that imposes Imminent Danger to the environment, employees or other persons in the area or Remote Site Location.
- 1.5 Hazardous Materials Brought On Site. Any hazardous materials brought into, used, stored or abandoned at the BellSouth Remote Site Location by Adelphia are owned by Adelphia. Adelphia will indemnify BellSouth for claims, lawsuits or damages to persons or property caused by these materials. Without prior written BellSouth approval, no substantial new safety or environmental hazards can be created by Adelphia or different hazardous materials used by Adelphia at the BellSouth Remote Site Location. Adelphia must demonstrate adequate emergency response capabilities for its materials used or remaining at the BellSouth Remote Site Location.

- 1.6 Spills and Releases. When contamination is discovered at a BellSouth Remote Site Location, the Party discovering the condition must notify BellSouth. All Spills or Releases of regulated materials will immediately be reported by Adelphia to BellSouth.
- 1.7 Coordinated Environmental Plans and Permits. BellSouth and Adelphia will coordinate plans, permits or information required to be submitted to government agencies, such as emergency response plans, spill prevention control and countermeasures (SPCC) plans and community reporting. If fees are associated with filing, BellSouth and Adelphia will develop a cost sharing procedure. If BellSouth’s permit or EPA identification number must be used, Adelphia must comply with all of BellSouth’s permit conditions and environmental processes, including environmental “best management practices (BMP)” (see Section 2, below) and/or selection of BST disposition vendors and disposal sites.
- 1.8 Environmental and Safety Indemnification. BellSouth and Adelphia shall indemnify, defend and hold harmless the other Party from and against any claims (including, without limitation, third-party claims for personal injury or death or real or personal property damage), judgments, damages, (including direct and indirect damages, and punitive damages), penalties, fines, forfeitures, costs, liabilities, interest and losses arising in connection with the violation or alleged violation of any Applicable Law or contractual obligation or the presence or alleged presence of contamination arising out of the acts or omissions of the indemnifying Party, its agents, suppliers, or employees concerning its operations at the Remote Site Location.

2. CATEGORIES FOR CONSIDERATION OF ENVIRONMENTAL ISSUES

- 2.1 When performing functions that fall under the following Environmental categories on BellSouth’s Remote Site Location, Adelphia agrees to comply with the applicable sections of the current issue of BellSouth’s Environmental and Safety Methods and Procedures (M&Ps), incorporated herein by this reference. Adelphia further agrees to cooperate with BellSouth to ensure that Adelphia’s employees, agents, and/or suppliers are knowledgeable of and satisfy those provisions of BellSouth’s Environmental M&Ps which apply to the specific Environmental function being performed by Adelphia, its employees, agents and/or suppliers.
- 2.1.1 The most current version of reference documentation must be requested from Adelphia’s BellSouth Account Team Collocation Coordinator (ATCC) Representative.

| ENVIRONMENTAL CATEGORIES | ENVIRONMENTAL ISSUES | ADDRESSED BY THE FOLLOWING DOCUMENTATION |
|--|---|---|
| Disposal of hazardous material or other regulated material (e.g., batteries, fluorescent tubes, solvents & cleaning materials) | Compliance with all applicable local, state, & federal laws and regulations Pollution liability insurance EVET approval of supplier | <ul style="list-style-type: none"> • Std T&C 450 • Fact Sheet Series 17000 • Std T&C 660-3 • Approved Environmental Vendor List (Contact ATCC |

| | | Representative) |
|---|--|--|
| Emergency response | Hazmat/waste release/spill fire safety emergency | <ul style="list-style-type: none"> • Fact Sheet Series 1700 • Building Emergency Operations Plan (EOP) (specific to and located on Remote Site Location) |
| Contract labor/outsourcing for services with environmental implications to be performed on BellSouth Remote Site Location (e.g., disposition of hazardous material/waste; maintenance of storage tanks) | <p>Compliance with all applicable local, state, & federal laws and regulations</p> <p>Performance of services in accordance with BST's environmental M&Ps</p> <p>Insurance</p> | <ul style="list-style-type: none"> • Std T&C 450 • Std T&C 450-B • (Contact ATCC Representative for copy of appropriate E/S M&Ps.) • Std T&C 660 |
| Transportation of hazardous material | <p>Compliance with all applicable local, state, & federal laws and regulations</p> <p>Pollution liability insurance</p> <p>EVET approval of supplier</p> | <ul style="list-style-type: none"> • Std T&C 450 • Fact Sheet Series 17000 • Std T&C 660-3 • Approved Environmental Vendor List (Contact ATCC Representative) |
| <p>Maintenance/operations work which may produce a waste</p> <p>Other maintenance work</p> | <p>Compliance with all applicable local, state, & federal laws and regulations</p> <p>Protection of BST employees and equipment</p> | <ul style="list-style-type: none"> • Std T&C 450 • 29CFR 1910.147 (OSHA Standard) • 29CFR 1910 Subpart O (OSHA Standard) |
| Janitorial services | <p>All waste removal and disposal must conform to all applicable federal, state and local regulations</p> <p>All Hazardous Material and Waste</p> <p>Asbestos notification and protection of employees and equipment</p> | <ul style="list-style-type: none"> • –Procurement Manager (CRES Related Matters)-BST Supply Chain Services • Fact Sheet Series 17000 • GU-BTEN-001BT, Chapter 3 • BSP 010-170-001BS (Hazcom) |

| | | |
|--|--|---|
| <p>Manhole cleaning</p> | <p>Compliance with all applicable local, state, & federal laws and regulations</p> <p>Pollution liability insurance</p> <p>EVET approval of supplier</p> | <ul style="list-style-type: none"> • Std T&C 450 • Fact Sheet 14050 • BSP 620-145-011PR Issue A, August 1996 • Std T&C 660-3 • Approved Environmental Vendor List (Contact ATCC Representative) |
| <p>Removing or disturbing building materials that may contain asbestos</p> | <p>Asbestos work practices</p> | <ul style="list-style-type: none"> • GU-BTEN-001BT, Chapter 3 <p>For questions regarding removing or disturbing materials that contain asbestos, call the BellSouth Building Service Center: AL, MS, TN, KY & LA (local area code) 557-6194 FL, GA, NC & SC (local area code) 780-2740</p> |

3. DEFINITIONS

Generator. Under RCRA, the person whose act produces a Hazardous Waste, as defined in 40 CFR 261, or whose act first causes a Hazardous Waste to become subject to regulation. The Generator is legally responsible for the proper management and disposal of Hazardous Wastes in accordance with regulations.

Hazardous Chemical. As defined in the U.S. Occupational Safety and Health (OSHA) hazard communication standard (29 CFR 1910.1200), any chemical which is a health hazard or physical hazard.

Hazardous Waste. As defined in section 1004 of RCRA.

Imminent Danger. Any conditions or practices at a facility which are such that a danger exists which could reasonably be expected to cause immediate death or serious harm to people or immediate significant damage to the environment or natural resources.

Spill or Release. As defined in Section 101 of CERCLA.

4. ACRONYMS

ATCC – Account Team Collocation Coordinator

BST – BellSouth Telecommunications

CRES – Corporate Real Estate and Services (formerly PS&M)

DEC/LDEC - Department Environmental Coordinator/Local Department Environmental Coordinator

E/S – Environmental/Safety

EVET - Environmental Vendor Evaluation Team

GU-BTEN-001BT - BellSouth Environmental Methods and Procedures

NESC - National Electrical Safety Codes

P&SM - Property & Services Management

Std T&C - Standard Terms & Conditions

| ODUF/EODUF- Kentucky | | | | | | | | | | Attachment: 1 | | Exhibit: G | | | |
|---|---|---------|------|-----|------|------------|--------------|-------|-------------------------|----------------------------------|--------------------------------------|--|--|---|---|
| CATEGORY | RATE ELEMENTS | Interim | Zone | BCS | USOC | RATES (\$) | | | | Svc Order Submitted Elec per LSR | Svc Order Submitted Manually per LSR | Incremental Charge - Manual Svc Order vs. Electronic-1st | Incremental Charge - Manual Svc Order vs. Electronic-Add'l | Incremental Charge - Manual Svc Order vs. Electronic-Disc 1st | Incremental Charge - Manual Svc Order vs. Electronic-Disc Add'l |
| | | | | | | Rec | Nonrecurring | | Nonrecurring Disconnect | | | | | | |
| | | | | | | | First | Add'l | First | Add'l | SOME C | SOMAN | SOMAN | SOMAN | SOMAN |
| ODUF/EoDUF/CMD5 | | | | | | | | | | | | | | | |
| | OPTIONAL DAILY USAGE FILE (ODUF) | | | | | | | | | | | | | | |
| | ODUF: Recording, per message | | | | N/A | 0.0000136 | | | | | | | | | |
| | ODUF: Message Processing, per message | | | | N/A | 0.002506 | | | | | | | | | |
| | ODUF: Message Processing, per Magnetic Tape provisioned | | | | N/A | 35.90 | | | | | | | | | |
| | ODUF: Data Transmission (CONNECT:DIRECT), per message | | | | N/A | 0.00010372 | | | | | | | | | |
| | ENHANCED OPTIONAL DAILY USAGE FILE (EODUF) | | | | | | | | | | | | | | |
| | EODUF: Message Processing, per message | | | | N/A | 0.235889 | | | | | | | | | |
| Notes: If no rate is identified in the contract, the rate for the specific service or function will be as set forth in applicable BellSouth tariff or as negotiated by the Parties upon request by either Party. | | | | | | | | | | | | | | | |

| UNBUNDLED NETWORK ELEMENTS - Kentucky | | | | | | | | | | Attachment: 2 | | Exhibit: D | | | | |
|--|--|---------|------|-------------|-------|-----------|--------------|-------|-------------------------|----------------------------------|--------------------------------------|---|---|--|--|---------------|
| CATEGORY | RATE ELEMENTS | Interim | Zone | BCS | USOC | RATES(\$) | | | | Svc Order Submitted Elec per LSR | Svc Order Submitted Manually per LSR | Incremental Charge - Manual Svc Order vs. Electronic- 1st | Incremental Charge - Manual Svc Order vs. Electronic- Add'l | Incremental Charge - Manual Svc Order vs. Electronic- Disc 1st | Incremental Charge - Manual Svc Order vs. Electronic- Disc Add'l | |
| | | | | | | Rec | Nonrecurring | | Nonrecurring Disconnect | | | | | | | OSS Rates(\$) |
| | | | | | | | First | Add'l | First | Add'l | SOMEK | SOMAN | SOMAN | SOMAN | SOMAN | SOMAN |
| The "Zone" shown in the sections for stand-alone loops or loops as part of a combination refers to Geographically Deaveraged UNE Zones. To view Geographically Deaveraged UNE Zone Designations by C O, refer to Internet Website: http://www.interconnection.bellsouth.com/become_a_clec/htm/interconnection.htm | | | | | | | | | | | | | | | | |
| OPERATIONAL SUPPORT SYSTEMS | | | | | | | | | | | | | | | | |
| NOTE: (1) Electronic Service Order: CLEC should contact its contract negotiator if it prefers the state specific electronic service ordering charges as ordered by the State Commissions. The electronic service ordering charge currently contained in this rate exhibit is the BellSouth regional electronic service ordering charge. CLEC may elect either the state specific Commission ordered rates for the electronic service ordering charges, or CLEC may elect the regional electronic service ordering charge. | | | | | | | | | | | | | | | | |
| NOTE: (2) Any element that can be ordered electronically will be billed according to the SOMEK rate listed in this category. Please refer to BellSouth's Business Rules for Local Ordering (BBR-LO) to determine if a product can be ordered electronically. For those elements that cannot be ordered electronically at present per the BBR-LO, the listed SOMEK rate in this category reflects the charge that would be billed to a CLEC once electronic ordering capabilities come on-line for that element. Otherwise, the manual ordering charge, SOMAN, will be applied to a CLECs bill when it submits an LSR to BellSouth. | | | | | | | | | | | | | | | | |
| | Manual Service Order Charge, per LSR, Disconnect Only (KY) | | | | SOMAN | | | | | | | | | | 0.99 | |
| | Electronic OSS Charge, per LSR, submitted via BST's OSS interactive interfaces (Regional) | | | | SOMEK | | 3.50 | | | | | | | | | |
| UNE SERVICE DATE ADVANCEMENT CHARGE | | | | | | | | | | | | | | | | |
| NOTE: The Expedite charge will be maintained commensurate with BellSouth's FCC No.1 Tariff, Section 5 as applicable. | | | | | | | | | | | | | | | | |
| | UNE Expedite Charge per Circuit or Line Assignable USOC, per Day | | | ALL UNE | SDASP | | 200.00 | | | | | | | | | |
| UNBUNDLED EXCHANGE ACCESS LOOP | | | | | | | | | | | | | | | | |
| 2-WIRE ANALOG VOICE GRADE LOOP | | | | | | | | | | | | | | | | |
| | 2-Wire Analog Voice Grade Loop - Service Level 1- Zone 1 | | 1 | UEANL | UEAL2 | 10.56 | 46.66 | 22.57 | 26.65 | 7.65 | | | | | 7.86 | |
| | 2-Wire Analog Voice Grade Loop - Service Level 1- Zone 2 | | 2 | UEANL | UEAL2 | 15.34 | 46.66 | 22.57 | 26.65 | 7.65 | | | | | 7.86 | |
| | 2-Wire Analog Voice Grade Loop - Service Level 1- Zone 3 | | 3 | UEANL | UEAL2 | 31.11 | 46.66 | 22.57 | 26.65 | 7.65 | | | | | 7.86 | |
| | Loop Testing - Basic 1st Half Hour | | | UEANL | URET1 | | 46.88 | 46.88 | | | | | | | 7.86 | |
| | Loop Testing - Basic Additional Half Hour | | | UEANL | URETA | | 24.16 | 24.16 | | | | | | | 7.86 | |
| | CLEC to CLEC Conversion Charge Without Outside Dispatch (UVL-SL1) | | | UEANL | UREWO | | 15.78 | 8.94 | | | | | | | 7.86 | |
| | Unbundled Voice Loop, Unbundled Non-Design Voice Loop, billing for BST providing make-up | | | UEANL | UEANM | | 13.49 | 13.49 | | | | | | | | |
| | Manual Order Coordination for UVL-SL1s (per loop) | | | UEANL | UEAMC | | 9.00 | 9.00 | | | | | | | | |
| | Order Coordination for Specified Conversion Time for UVL-SL1 (per LSR) | | | UEANL | OCOSL | | 23.01 | 23.01 | | | | | | | | |
| 2-WIRE Unbundled COPPER LOOP | | | | | | | | | | | | | | | | |
| | 2-Wire Unbundled Copper Loop - Non-Designed Zone 1 | | I 1 | UEQ | UEQ2X | 10.58 | 44.97 | 20.89 | 25.64 | 6.65 | | | | | 7.86 | |
| | 2 Wire Unbundled Copper Loop - Non-Designed - Zone 2 | | I 2 | UEQ | UEQ2X | 11.51 | 44.97 | 20.89 | 25.64 | 6.65 | | | | | 7.86 | |
| | 2 Wire Unbundled Copper Loop - Non-Designed - Zone 3 | | I 3 | UEQ | UEQ2X | 13.19 | 44.97 | 20.89 | 25.64 | 6.65 | | | | | 7.86 | |
| | Order Coordination 2 Wire Unbundled Copper Loop - Non-Designed (per loop) | | | UEQ | USBMC | | 9.00 | 9.00 | | | | | | | | |
| | Unbundled Copper Loop, Non-Designed Billing for BST providing make-up | | | UEQ | UEQMU | | 13.49 | 13.49 | | | | | | | | |
| | Loop Testing - Basic 1st Half Hour | | | UEQ | URET1 | | 46.88 | 46.88 | | | | | | | 7.86 | |
| | Loop Testing - Basic Additional Half Hour | | | UEQ | URETA | | 24.16 | 24.16 | | | | | | | 7.86 | |
| | CLEC to CLEC Conversion Charge Without Outside Dispatch (UCL-ND) | | | UEQ | UREWO | | 14.27 | 7.43 | | | | | | | 7.86 | |
| UNBUNDLED EXCHANGE ACCESS LOOP | | | | | | | | | | | | | | | | |
| 2-WIRE ANALOG VOICE GRADE LOOP | | | | | | | | | | | | | | | | |
| | 2 Wire Analog Voice Grade Loop-Service Level 1-Line Splitting- Zone 1 | | 1 | UEPSR UEPSB | UEALS | 10.56 | 46.66 | 22.57 | 26.65 | 7.65 | | | | | 7.86 | |
| | 2 Wire Analog Voice Grade Loop-Service Level 1-Line Splitting- Zone 1 | | 1 | UEPSR UEPSB | UEABS | 10.56 | 46.66 | 22.57 | 26.65 | 7.65 | | | | | 7.86 | |
| | 2 Wire Analog Voice Grade Loop- Service Level 1-Line Splitting- Zone 2 | | 2 | UEPSR UEPSB | UEALS | 15.34 | 46.66 | 22.57 | 26.65 | 7.65 | | | | | 7.86 | |
| | 2 Wire Analog Voice Grade Loop-Service Level 1-Line Splitting- Zone 2 | | 2 | UEPSR UEPSB | UEABS | 15.34 | 46.66 | 22.57 | 26.65 | 7.65 | | | | | 7.86 | |
| | 2 Wire Analog Voice Grade Loop-Service Level 1-Line Splitting- Zone 3 | | 3 | UEPSR UEPSB | UEALS | 31.11 | 46.66 | 22.57 | 26.65 | 7.65 | | | | | 7.86 | |
| | 2 Wire Analog Voice Grade Loop-Service Level 1-Line Splitting- Zone 3 | | 3 | UEPSR UEPSB | UEABS | 31.11 | 46.66 | 22.57 | 26.65 | 7.65 | | | | | 7.86 | |
| UNE Loop Rates for Line Splitting | | | | | | | | | | | | | | | | |
| | 2-Wire Voice Grade Loop (SL1) for Line Splitting - Zone 1 | | 1 | UEPRX | UEPLX | 10.79 | | | | | | | | | | |
| | 2-Wire Voice Grade Loop (SL1) for Line Splitting - Zone 2 | | 2 | UEPRX | UEPLX | 15.52 | | | | | | | | | | |
| | 2-Wire Voice Grade Loop (SL1)for Line Splitting - Zone 3 | | 3 | UEPRX | UEPLX | 31.74 | | | | | | | | | | |
| UNBUNDLED EXCHANGE ACCESS LOOP | | | | | | | | | | | | | | | | |
| 2-WIRE ANALOG VOICE GRADE LOOP | | | | | | | | | | | | | | | | |
| | 2-Wire Analog Voice Grade Loop - Service Level 2 w/Loop or Ground Start Signaling - Zone 1 | | 1 | UEA | UEAL2 | 12.67 | 134.89 | 81.87 | 73.65 | 14.88 | | | | | 7.86 | |

| UNBUNDLED NETWORK ELEMENTS - Kentucky | | | | | | | | | | | Attachment: 2 | | Exhibit: D | | |
|---------------------------------------|---|---------|------|-----|-------|-----------|--------------|--------|-------------------------|----------------------------------|--------------------------------------|--|--|---|---|
| CATEGORY | RATE ELEMENTS | Interim | Zone | BCS | USOC | RATES(\$) | | | | Svc Order Submitted Elec per LSR | Svc Order Submitted Manually per LSR | Incremental Charge - Manual Svc Order vs. Electronic-1st | Incremental Charge - Manual Svc Order vs. Electronic-Add'l | Incremental Charge - Manual Svc Order vs. Electronic-Disc 1st | Incremental Charge - Manual Svc Order vs. Electronic-Disc Add'l |
| | | | | | | Rec | Nonrecurring | | Nonrecurring Disconnect | | | | | | |
| | | | | | | | First | Add'l | First | Add'l | SOMEc | SOMAN | SOMAN | SOMAN | SOMAN |
| | 2-Wire Analog Voice Grade Loop - Service Level 2 w/Loop or Ground Start Signaling - Zone 2 | | 2 | UEA | UEAL2 | 17.45 | 134.89 | 81.87 | 73.65 | 14.88 | | 7.86 | | | |
| | 2-Wire Analog Voice Grade Loop - Service Level 2 w/Loop or Ground Start Signaling - Zone 3 | | 3 | UEA | UEAL2 | 33.22 | 134.89 | 81.87 | 73.65 | 14.88 | | 7.86 | | | |
| | Order Coordination for Specified Conversion Time (per LSR) | | | UEA | OCOSL | | 23.01 | | | | | | | | |
| | 2-Wire Analog Voice Grade Loop - Service Level 2 w/Reverse Battery Signaling - Zone 1 | | 1 | UEA | UEAR2 | 12.67 | 134.89 | 81.87 | 73.65 | 14.88 | | 7.86 | | | |
| | 2-Wire Analog Voice Grade Loop - Service Level 2 w/Reverse Battery Signaling - Zone 2 | | 2 | UEA | UEAR2 | 17.45 | 134.89 | 81.87 | 73.65 | 14.88 | | 7.86 | | | |
| | 2-Wire Analog Voice Grade Loop - Service Level 2 w/Reverse Battery Signaling - Zone 3 | | 3 | UEA | UEAR2 | 33.22 | 134.89 | 81.87 | 73.65 | 14.88 | | 7.86 | | | |
| | Order Coordination for Specified Conversion Time (per LSR) | | | UEA | OCOSL | | 23.01 | | | | | | | | |
| | CLEC to CLEC Conversion Charge without outside dispatch | | | UEA | UREWO | | 87.72 | 36.36 | | | | 7.86 | | | |
| | 4-WIRE ANALOG VOICE GRADE LOOP | | | | | | | | | | | | | | |
| | 4-Wire Analog Voice Grade Loop - Zone 1 | | 1 | UEA | UEAL4 | 29.26 | 164.11 | 112.36 | 78.91 | 18.66 | | 7.86 | | | |
| | 4-Wire Analog Voice Grade Loop - Zone 2 | | 2 | UEA | UEAL4 | 34.25 | 164.11 | 112.36 | 78.91 | 18.66 | | 7.86 | | | |
| | 4-Wire Analog Voice Grade Loop - Zone 3 | | 3 | UEA | UEAL4 | 85.06 | 164.11 | 112.36 | 78.91 | 18.66 | | 7.86 | | | |
| | Order Coordination for Specified Conversion Time (per LSR) | | | UEA | OCOSL | | 23.01 | | | | | | | | |
| | CLEC to CLEC Conversion Charge without outside dispatch | | | UEA | UREWO | | 87.72 | 36.36 | | | | 7.86 | | | |
| | 2-WIRE ISDN DIGITAL GRADE LOOP | | | | | | | | | | | | | | |
| | 2-Wire ISDN Digital Grade Loop - Zone 1 | | 1 | UDN | U1L2X | 18.44 | 146.77 | 95.02 | 71.38 | 13.83 | | 7.86 | | | |
| | 2-Wire ISDN Digital Grade Loop - Zone 2 | | 2 | UDN | U1L2X | 25.08 | 146.77 | 95.02 | 71.38 | 13.83 | | 7.86 | | | |
| | 2-Wire ISDN Digital Grade Loop - Zone 3 | | 3 | UDN | U1L2X | 42.87 | 146.77 | 95.02 | 71.38 | 13.83 | | 7.86 | | | |
| | Order Coordination For Specified Conversion Time (per LSR) | | | UDN | OCOSL | | 23.01 | | | | | | | | |
| | CLEC to CLEC Conversion Charge without outside dispatch | | | UDN | UREWO | | 91.63 | 44.16 | | | | 7.86 | | | |
| | 2-WIRE Universal Digital Channel (UDC) COMPATIBLE LOOP | | | | | | | | | | | | | | |
| | 2-Wire Universal Digital Channel (UDC) Compatible Loop - Zone 1 | | 1 | UDC | UDC2X | 18.44 | 146.77 | 95.02 | 71.38 | 13.83 | | 7.86 | | | |
| | 2-Wire Universal Digital Channel (UDC) Compatible Loop - Zone 2 | | 2 | UDC | UDC2X | 25.08 | 146.77 | 95.02 | 71.38 | 13.83 | | 7.86 | | | |
| | 2-Wire Universal Digital Channel (UDC) Compatible Loop - Zone 3 | | 3 | UDC | UDC2X | 42.87 | 146.77 | 95.02 | 71.38 | 13.83 | | 7.86 | | | |
| | CLEC to CLEC Conversion Charge without outside dispatch | | | UDC | UREWO | | 91.63 | 44.16 | | | | 7.86 | | | |
| | 2-WIRE ASYMMETRICAL DIGITAL SUBSCRIBER LINE (ADSL) COMPATIBLE LOOP | | | | | | | | | | | | | | |
| | 2 Wire Unbundled ADSL Loop including manual service inquiry & facility reservation - Zone 1 | | 1 | UAL | UAL2X | 10.82 | 141.98 | 79.73 | 69.02 | 11.47 | | 7.86 | | | |
| | 2 Wire Unbundled ADSL Loop including manual service inquiry & facility reservation - Zone 2 | | 2 | UAL | UAL2X | 11.79 | 141.98 | 79.73 | 69.02 | 11.47 | | 7.86 | | | |
| | 2 Wire Unbundled ADSL Loop including manual service inquiry & facility reservation - Zone 3 | | 3 | UAL | UAL2X | 12.87 | 141.98 | 79.73 | 69.02 | 11.47 | | 7.86 | | | |
| | Order Coordination for Specified Conversion Time (per LSR) | | | UAL | OCOSL | | 23.01 | | | | | | | | |
| | 2 Wire Unbundled ADSL Loop without manual service inquiry & facility reservation - Zone 1 | | 1 | UAL | UAL2W | 10.82 | 121.18 | 69.00 | 69.09 | 11.54 | | 7.86 | | | |
| | 2 Wire Unbundled ADSL Loop without manual service inquiry & facility reservation - Zone 2 | | 2 | UAL | UAL2W | 11.79 | 121.18 | 69.00 | 69.09 | 11.54 | | 7.86 | | | |
| | 2 Wire Unbundled ADSL Loop without manual service inquiry & facility reservation - Zone 3 | | 3 | UAL | UAL2W | 12.87 | 121.18 | 69.00 | 69.09 | 11.54 | | 7.86 | | | |
| | Order Coordination for Specified Conversion Time (per LSR) | | | UAL | OCOSL | | 23.01 | | | | | | | | |
| | CLEC to CLEC Conversion Charge without outside dispatch | | | UAL | UREWO | | 86.20 | 40.40 | | | | 7.86 | | | |
| | 2-WIRE HIGH BIT RATE DIGITAL SUBSCRIBER LINE (HDSL) COMPATIBLE LOOP | | | | | | | | | | | | | | |
| | 2 Wire Unbundled HDSL Loop including manual service inquiry & facility reservation - Zone 1 | | 1 | UHL | UHL2X | 8.75 | 151.54 | 89.29 | 69.09 | 11.54 | | 7.86 | | | |
| | 2 Wire Unbundled HDSL Loop including manual service inquiry & facility reservation - Zone 2 | | 2 | UHL | UHL2X | 9.56 | 151.54 | 89.29 | 69.09 | 11.54 | | 7.86 | | | |
| | 2 Wire Unbundled HDSL Loop including manual service inquiry & facility reservation - Zone 3 | | 3 | UHL | UHL2X | 10.61 | 151.54 | 89.29 | 69.09 | 11.54 | | 7.86 | | | |
| | Order Coordination for Specified Conversion Time (per LSR) | | | UHL | OCOSL | | 23.01 | | | | | | | | |
| | 2 Wire Unbundled HDSL Loop without manual service inquiry and facility reservation - Zone 1 | | 1 | UHL | UHL2W | 8.75 | 130.74 | 78.56 | 69.09 | 11.54 | | 7.86 | | | |
| | 2 Wire Unbundled HDSL Loop without manual service inquiry and facility reservation - Zone 2 | | 2 | UHL | UHL2W | 9.56 | 130.74 | 78.56 | 69.09 | 11.54 | | 7.86 | | | |
| | 2 Wire Unbundled HDSL Loop without manual service inquiry and facility reservation - Zone 3 | | 3 | UHL | UHL2W | 10.61 | 130.74 | 78.56 | 69.09 | 11.54 | | 7.86 | | | |
| | Order Coordination for Specified Conversion Time (per LSR) | | | UHL | OCOSL | | 23.01 | | | | | | | | |

| UNBUNDLED NETWORK ELEMENTS - Kentucky | | | | | | | | | | | Attachment: 2 | | Exhibit: D | | | |
|---------------------------------------|--|---------|------|-----|-------|-----------|--------------|--------|-------------------------|----------------------------------|--------------------------------------|--|---|---|---------------|-------|
| CATEGORY | RATE ELEMENTS | Interim | Zone | BCS | USOC | RATES(\$) | | | | Svc Order Submitted Elec per LSR | Svc Order Submitted Manually per LSR | Incremental Charge - Manual Svc Order vs. Electronic-1st | Incremental Charge - Manual Svc Order vs. Electronic-Disc 1st | Incremental Charge - Manual Svc Order vs. Electronic-Disc Add'l | | |
| | | | | | | Rec | Nonrecurring | | Nonrecurring Disconnect | | | | | | OSS Rates(\$) | |
| | | | | | | | First | Add'l | First | Add'l | SOMEC | SOMAN | SOMAN | SOMAN | SOMAN | SOMAN |
| | CLEC to CLEC Conversion Charge without outside dispatch | | | UHL | UREWO | | 86.14 | 40.40 | | | | 7.86 | | | | |
| | 4-WIRE HIGH BIT RATE DIGITAL SUBSCRIBER LINE (HDSL) COMPATIBLE LOOP | | | | | | | | | | | | | | | |
| | 4 Wire Unbundled HDSL Loop including manual service inquiry and facility reservation - Zone 1 | | 1 | UHL | UHL4X | 13.95 | 185.75 | 123.50 | 74.95 | 14.69 | | 7.86 | | | | |
| | 4-Wire Unbundled HDSL Loop including manual service inquiry and facility reservation - Zone 2 | I | 2 | UHL | UHL4X | 15.68 | 185.75 | 123.50 | 74.95 | 14.69 | | 7.86 | | | | |
| | 4-Wire Unbundled HDSL Loop including manual service inquiry and facility reservation - Zone 3 | | 3 | UHL | UHL4X | 16.98 | 185.75 | 123.50 | 74.95 | 14.69 | | 7.86 | | | | |
| | Order Coordination for Specified Conversion Time (per LSR) | | | UHL | OCOSL | | 23.01 | | | | | | | | | |
| | 4-Wire Unbundled HDSL Loop without manual service inquiry and facility reservation - Zone 1 | | 1 | UHL | UHL4W | 13.95 | 164.95 | 114.04 | 77.32 | 15.80 | | 7.86 | | | | |
| | 4-Wire Unbundled HDSL Loop without manual service inquiry and facility reservation - Zone 2 | | 2 | UHL | UHL4W | 15.68 | 164.95 | 114.04 | 77.32 | 15.80 | | 7.86 | | | | |
| | 4-Wire Unbundled HDSL Loop without manual service inquiry and facility reservation - Zone 3 | | 3 | UHL | UHL4W | 16.98 | 164.95 | 114.04 | 77.32 | 15.80 | | 7.86 | | | | |
| | Order Coordination for Specified Conversion Time (per LSR) | | | UHL | OCOSL | | 23.01 | | | | | | | | | |
| | CLEC to CLEC Conversion Charge without outside dispatch | | | UHL | UREWO | | 86.14 | 40.40 | | | | 7.86 | | | | |
| | 4-WIRE DS1 DIGITAL LOOP | | | | | | | | | | | | | | | |
| | 4-Wire DS1 Digital Loop - Zone 1 | | 1 | USL | USLXX | 86.47 | 306.69 | 174.44 | 65.83 | 14.55 | | 7.86 | | | | |
| | 4-Wire DS1 Digital Loop - Zone 2 | | 2 | USL | USLXX | 114.10 | 306.69 | 174.44 | 65.83 | 14.55 | | 7.86 | | | | |
| | 4-Wire DS1 Digital Loop - Zone 3 | | 3 | USL | USLXX | 297.76 | 306.69 | 174.44 | 65.83 | 14.55 | | 7.86 | | | | |
| | Order Coordination for Specified Conversion Time (per LSR) | | | USL | OCOSL | | 23.01 | | | | | | | | | |
| | CLEC to CLEC Conversion Charge without outside dispatch | | | USL | UREWO | | 101.09 | 43.04 | | | | | | | | |
| | 4-WIRE 19.2, 56 OR 64 KBPS DIGITAL GRADE LOOP | | | | | | | | | | | | | | | |
| | 4 Wire Unbundled Digital 19.2 Kbps | | 1 | UDL | UDL19 | 27.59 | 157.81 | 106.06 | 78.91 | 18.66 | | 7.86 | | | | |
| | 4 Wire Unbundled Digital 19.2 Kbps | | 2 | UDL | UDL19 | 32.48 | 157.81 | 106.06 | 78.91 | 18.66 | | 7.86 | | | | |
| | 4 Wire Unbundled Digital 19.2 Kbps | | 3 | UDL | UDL19 | 36.37 | 157.81 | 106.06 | 78.91 | 18.66 | | 7.86 | | | | |
| | 4 Wire Unbundled Digital Loop 56 Kbps - Zone 1 | | 1 | UDL | UDL56 | 27.59 | 157.81 | 106.06 | 78.91 | 18.66 | | 7.86 | | | | |
| | 4 Wire Unbundled Digital Loop 56 Kbps - Zone 2 | | 2 | UDL | UDL56 | 32.48 | 157.81 | 106.06 | 78.91 | 18.66 | | 7.86 | | | | |
| | 4 Wire Unbundled Digital Loop 56 Kbps - Zone 3 | | 3 | UDL | UDL56 | 36.37 | 157.81 | 106.06 | 78.91 | 18.66 | | 7.86 | | | | |
| | Order Coordination for Specified Conversion Time (per LSR) | | | UDL | OCOSL | | 23.01 | | | | | | | | | |
| | 4 Wire Unbundled Digital Loop 64 Kbps - Zone 1 | | 1 | UDL | UDL64 | 27.59 | 157.81 | 106.06 | 78.91 | 18.66 | | 7.86 | | | | |
| | 4 Wire Unbundled Digital Loop 64 Kbps - Zone 2 | | 2 | UDL | UDL64 | 32.48 | 157.81 | 106.06 | 78.91 | 18.66 | | 7.86 | | | | |
| | 4 Wire Unbundled Digital Loop 64 Kbps - Zone 3 | | 3 | UDL | UDL64 | 36.37 | 157.81 | 106.06 | 78.91 | 18.66 | | 7.86 | | | | |
| | Order Coordination for Specified Conversion Time (per LSR) | | | UDL | OCOSL | | 23.01 | | | | | | | | | |
| | CLEC to CLEC Conversion Charge without outside dispatch | | | UDL | UREWO | | 102.13 | 49.75 | | | | 7.86 | | | | |
| | 2-WIRE Unbundled COPPER LOOP | | | | | | | | | | | | | | | |
| | 2-Wire Unbundled Copper Loop/Short including manual service inquiry & facility reservation - Zone 1 | | 1 | UCL | UCLPB | 10.82 | 140.95 | 78.70 | 69.09 | 11.54 | | 7.86 | | | | |
| | 2-Wire Unbundled Copper Loop/Short including manual service inquiry & facility reservation - Zone 2 | | 2 | UCL | UCLPB | 11.79 | 140.95 | 78.70 | 69.09 | 11.54 | | 7.86 | | | | |
| | 2 Wire Unbundled Copper Loop/Short including manual service inquiry & facility reservation - Zone 3 | | 3 | UCL | UCLPB | 12.87 | 140.95 | 78.70 | 69.09 | 11.54 | | 7.86 | | | | |
| | Order Coordination for Unbundled Copper Loops (per loop) | | | UCL | UCLMC | | 9.00 | 9.00 | | | | | | | | |
| | 2-Wire Unbundled Copper Loop/Short without manual service inquiry and facility reservation - Zone 1 | | 1 | UCL | UCLPW | 10.82 | 120.15 | 67.97 | 69.09 | 11.54 | | 7.86 | | | | |
| | 2-Wire Unbundled Copper Loop/Short without manual service inquiry and facility reservation - Zone 2 | | 2 | UCL | UCLPW | 11.79 | 120.15 | 67.97 | 69.09 | 11.54 | | 7.86 | | | | |
| | 2-Wire Unbundled Copper Loop/Short without manual service inquiry and facility reservation - Zone 3 | | 3 | UCL | UCLPW | 12.87 | 120.15 | 67.97 | 69.09 | 11.54 | | 7.86 | | | | |
| | Order Coordination for Unbundled Copper Loops (per loop) | | | UCL | UCLMC | | 9.00 | 9.00 | | | | | | | | |
| | 2-Wire Unbundled Copper Loop/Long - includes manual svc. inquiry and facility reservation - Zone 1 | | 1 | UCL | UCL2L | 24.91 | 140.95 | 78.70 | 69.09 | 11.54 | | 7.86 | | | | |
| | 2-Wire Unbundled Copper Loop/Long - includes manual svc. inquiry and facility reservation - Zone 2 | | 2 | UCL | UCL2L | 36.94 | 140.95 | 78.70 | 69.09 | 11.54 | | 7.86 | | | | |
| | 2-Wire Unbundled Copper Loop/Long - includes manual svc. inquiry and facility reservation - Zone 3 | | 3 | UCL | UCL2L | 69.95 | 140.95 | 78.70 | 69.09 | 11.54 | | 7.86 | | | | |
| | Order Coordination for Unbundled Copper Loops (per loop) | | | UCL | UCLMC | | 9.00 | 9.00 | | | | | | | | |
| | 2-Wire Unbundled Copper Loop/Long - without manual service inquiry and facility reservation - Zone 1 | | 1 | UCL | UCL2W | 24.91 | 120.15 | 67.97 | 69.09 | 11.54 | | 7.86 | | | | |
| | 2-Wire Unbundled Copper Loop/Long - without manual service inquiry and facility reservation - Zone 2 | | 2 | UCL | UCL2W | 36.94 | 120.15 | 67.97 | 69.09 | 11.54 | | 7.86 | | | | |
| | 2-Wire Unbundled Copper Loop/Long - without manual service inquiry and facility reservation - Zone 3 | | 3 | UCL | UCL2W | 69.95 | 120.15 | 67.97 | 69.09 | 11.54 | | 7.86 | | | | |

| UNBUNDLED NETWORK ELEMENTS - Kentucky | | | | | | | | | | | Attachment: 2 | | Exhibit: D | | |
|---------------------------------------|--|---------|------|---|-------|-----------|--------------|--------|-------------------------|----------------------------------|--------------------------------------|--|--|---|---|
| CATEGORY | RATE ELEMENTS | Interim | Zone | BCS | USOC | RATES(\$) | | | | Svc Order Submitted Elec per LSR | Svc Order Submitted Manually per LSR | Incremental Charge - Manual Svc Order vs. Electronic-1st | Incremental Charge - Manual Svc Order vs. Electronic-Add'l | Incremental Charge - Manual Svc Order vs. Electronic-Disc 1st | Incremental Charge - Manual Svc Order vs. Electronic-Disc Add'l |
| | | | | | | Rec | Nonrecurring | | Nonrecurring Disconnect | | | | | | |
| | | | | | | | First | Add'l | First | Add'l | SOMEc | SOMAN | SOMAN | SOMAN | SOMAN |
| | Order Coordination for Unbundled Copper Loops (per loop) | | | UCL | UCLMC | | 9.00 | 9.00 | | | | | | | |
| | CLEC to CLEC Conversion Charge without outside dispatch (UCL-Des) | | | UCL | UREWO | | 97.23 | 42.48 | | | | 7.86 | | | |
| | 4-WIRE COPPER LOOP | | | | | | | | | | | | | | |
| | 4-Wire Copper Loop/Short - including manual service inquiry and facility reservation - Zone 1 | | 1 | UCL | UCL4S | 16.92 | 170.31 | 108.06 | 74.95 | 14.69 | | 7.86 | | | |
| | 4-Wire Copper Loop/Short - including manual service inquiry and facility reservation - Zone 2 | | 2 | UCL | UCL4S | 17.36 | 170.31 | 108.06 | 74.95 | 14.69 | | 7.86 | | | |
| | 4-Wire Copper Loop/Short - including manual service inquiry and facility reservation - Zone 3 | | 3 | UCL | UCL4S | 28.10 | 170.31 | 108.06 | 74.95 | 14.69 | | 7.86 | | | |
| | Order Coordination for Unbundled Copper Loops (per loop) | | | UCL | UCLMC | | 9.00 | 9.00 | | | | | | | |
| | 4-Wire Copper Loop/Short - without manual service inquiry and facility reservation - Zone 1 | | 1 | UCL | UCL4W | 16.92 | 149.52 | 97.33 | 74.95 | 14.69 | | 7.86 | | | |
| | 4-Wire Copper Loop/Short - without manual service inquiry and facility reservation - Zone 2 | | 2 | UCL | UCL4W | 17.36 | 149.52 | 97.33 | 74.95 | 14.69 | | 7.86 | | | |
| | 4-Wire Copper Loop/Short - without manual service inquiry and facility reservation - Zone 3 | | 3 | UCL | UCL4W | 28.10 | 149.52 | 97.33 | 74.95 | 14.69 | | 7.86 | | | |
| | Order Coordination for Unbundled Copper Loops (per loop) | | | UCL | UCLMC | | 9.00 | 9.00 | | | | | | | |
| | 4-Wire Unbundled Copper Loop/Long - includes manual svc. inquiry and facility reservation - Zone 1 | | 1 | UCL | UCL4L | 46.91 | 170.31 | 108.06 | 74.95 | 14.69 | | 7.86 | | | |
| | 4-Wire Unbundled Copper Loop/Long - includes manual svc. inquiry and facility reservation - Zone 2 | | 2 | UCL | UCL4L | 45.78 | 170.31 | 108.06 | 74.95 | 14.69 | | 7.86 | | | |
| | 4-Wire Unbundled Copper Loop/Long - includes manual svc. inquiry and facility reservation - Zone 3 | | 3 | UCL | UCL4L | 171.34 | 170.31 | 108.06 | 74.95 | 14.69 | | 7.86 | | | |
| | Order Coordination for Unbundled Copper Loops (per loop) | | | UCL | UCLMC | | 9.00 | 9.00 | | | | | | | |
| | 4-Wire Unbundled Copper Loop/Long - without manual svc. inquiry and facility reservation - Zone 1 | | 1 | UCL | UCL4O | 46.91 | 149.52 | 97.33 | 74.95 | 14.69 | | 7.86 | | | |
| | 4-Wire Unbundled Copper Loop/Long - without manual svc. inquiry and facility reservation - Zone 2 | | 2 | UCL | UCL4O | 45.78 | 149.52 | 97.33 | 74.95 | 14.69 | | 7.86 | | | |
| | 4-Wire Unbundled Copper Loop/Long - without manual svc. inquiry and facility reservation - Zone 3 | | 3 | UCL | UCL4O | 171.34 | 149.52 | 97.33 | 74.95 | 14.69 | | 7.86 | | | |
| | Order Coordination for Unbundled Copper Loops (per loop) | | | UCL | UCLMC | | 9.00 | 9.00 | | | | | | | |
| | CLEC to CLEC Conversion Charge without outside dispatch (UCL-Des) | | | UCL | UREWO | | 97.23 | 42.48 | | | | 7.86 | | | |
| | LOOP MODIFICATION | | | | | | | | | | | | | | |
| | Unbundled Loop Modification, Removal of Load Coils - 2 Wire pair less than or equal to 18k ft | | | UAL, UHL, UCL, UEQ, ULS, UEA, UEANL, UDL, UDC, UDN, UDL, USL | ULM2L | | 9.24 | 9.24 | | | | 7.86 | | | |
| | Unbundled Loop Modification, Removal of Load Coils - 2 wire greater than 18k ft | | | UCL, ULS, UEQ | ULM2G | | 342.24 | 342.24 | | | | 7.86 | | | |
| | Unbundled Loop Modification Removal of Load Coils - 4 Wire less than or equal to 18K ft | | | UHL, UCL | ULM4L | | 9.24 | 9.24 | | | | 7.86 | | | |
| | Unbundled Loop Modification Removal of Load Coils - 4 Wire pair greater than 18k ft | | | UCL | ULM4G | | 342.24 | 342.24 | | | | 7.86 | | | |
| | Unbundled Loop Modification Removal of Bridged Tap Removal, per unbundled loop | | | UAL, UHL, UCL, UEQ, UEF, ULS, UEA, UEANL, UDL, UDC, UDN, UDL, USL | ULMBT | | 10.47 | 10.47 | | | | 7.86 | | | |
| | SUB-LOOPS | | | | | | | | | | | | | | |
| | Sub-Loop Distribution | | | | | | | | | | | | | | |
| | Sub-Loop - Per Cross Box Location - CLEC Feeder Facility Set-Up | | I | UEANL | USBSA | | 207.91 | 207.91 | | | | 7.86 | | | |
| | Sub-Loop - Per Cross Box Location - Per 25 Pair Panel Set-Up | | I | UEANL | USBSB | | 12.50 | 12.50 | | | | 7.86 | | | |
| | Sub-Loop - Per Building Equipment Room - CLEC Feeder Facility Set-Up | | I | UEANL | USBSC | | 80.87 | 80.87 | | | | 7.86 | | | |
| | Sub-Loop - Per Building Equipment Room - Per 25 Pair Panel Set-Up | | I | UEANL | USBSD | | 45.04 | 45.04 | | | | 7.86 | | | |
| | Sub-Loop Distribution Per 2-Wire Analog Voice Grade Loop - Zone 1 | | I | 1 | UEANL | USBN2 | 6.34 | 85.03 | 39.05 | 59.81 | 7.90 | 7.86 | | | |
| | Sub-Loop Distribution Per 2-Wire Analog Voice Grade Loop - Zone 2 | | I | 2 | UEANL | USBN2 | 9.06 | 85.03 | 39.05 | 59.81 | 7.90 | 7.86 | | | |

| UNBUNDLED NETWORK ELEMENTS - Kentucky | | | | | | | | | | | Attachment: 2 | | Exhibit: D | | | |
|---------------------------------------|--|---------|------|----------------------|-------|-----------|--------------|-------|-------------------------|----------------------------------|--------------------------------------|--|--|---|---|---------------|
| CATEGORY | RATE ELEMENTS | Interim | Zone | BCS | USOC | RATES(\$) | | | | Svc Order Submitted Elec per LSR | Svc Order Submitted Manually per LSR | Incremental Charge - Manual Svc Order vs. Electronic-1st | Incremental Charge - Manual Svc Order vs. Electronic-Add'l | Incremental Charge - Manual Svc Order vs. Electronic-Disc 1st | Incremental Charge - Manual Svc Order vs. Electronic-Disc Add'l | |
| | | | | | | Rec | Nonrecurring | | Nonrecurring Disconnect | | | | | | | OSS Rates(\$) |
| | | | | | | | First | Add'l | First | Add'l | SOMEc | SOMAN | SOMAN | SOMAN | SOMAN | SOMAN |
| | Sub-Loop Distribution Per 2-Wire Analog Voice Grade Loop - Zone 3 | I | 3 | UEANL | USBN2 | 14.82 | 85.03 | 39.05 | 59.81 | 7.90 | | 7.86 | | | | |
| | Order Coordination for Unbundled Sub-Loops, per sub-loop pair | | | UEANL | USBMC | | 9.00 | 9.00 | | | | | | | | |
| | Sub-Loop Distribution Per 4-Wire Analog Voice Grade Loop - Zone 1 | | 1 | UEANL | USBN4 | 8.14 | 102.31 | 56.32 | 65.24 | 10.88 | | 7.86 | | | | |
| | Sub-Loop Distribution Per 4-Wire Analog Voice Grade Loop - Zone 2 | | 2 | UEANL | USBN4 | 8.63 | 102.31 | 56.32 | 65.24 | 10.88 | | 7.86 | | | | |
| | Sub-Loop Distribution Per 4-Wire Analog Voice Grade Loop - Zone 3 | | 3 | UEANL | USBN4 | 25.60 | 102.31 | 56.32 | 65.24 | 10.88 | | 7.86 | | | | |
| | Order Coordination for Unbundled Sub-Loops, per sub-loop pair | | | UEANL | USBMC | | 9.00 | 9.00 | | | | | | | | |
| | Sub-Loop 2-Wire Intra-building Network Cable (INC) | I | | UEANL | USBR2 | 2.57 | 68.35 | 22.36 | 59.81 | 7.90 | | 7.86 | | | | |
| | Order Coordination for Unbundled Sub-Loops, per sub-loop pair | | | UEANL | USBMC | | 9.00 | 9.00 | | | | | | | | |
| | Sub-Loop 4-Wire Intra-building Network Cable (INC) | I | | UEANL | USBR4 | 4.98 | 76.49 | 30.51 | 65.24 | 10.88 | | 7.86 | | | | |
| | Order Coordination for Unbundled Sub-Loops, per sub-loop pair | | | UEANL | USBMC | | 9.00 | 9.00 | | | | | | | | |
| | 2 Wire Copper Unbundled Sub-Loop Distribution - Zone 1 | I | 1 | UEF | UCS2X | 5.45 | 85.03 | 39.05 | 59.81 | 7.90 | | 7.86 | | | | |
| | 2 Wire Copper Unbundled Sub-Loop Distribution - Zone 2 | I | 2 | UEF | UCS2X | 7.06 | 85.03 | 39.05 | 59.81 | 7.90 | | 7.86 | | | | |
| | 2 Wire Copper Unbundled Sub-Loop Distribution - Zone 3 | I | 3 | UEF | UCS2X | 9.67 | 85.03 | 39.05 | 59.81 | 7.90 | | 7.86 | | | | |
| | Order Coordination for Unbundled Sub-Loops, per sub-loop pair | | | UEF | USBMC | | 9.00 | 9.00 | | | | | | | | |
| | 4 Wire Copper Unbundled Sub-Loop Distribution - Zone 1 | I | 1 | UEF | UCS4X | 7.09 | 102.31 | 56.32 | 65.24 | 10.88 | | 7.86 | | | | |
| | 4 Wire Copper Unbundled Sub-Loop Distribution - Zone 2 | I | 2 | UEF | UCS4X | 8.66 | 102.31 | 56.32 | 65.24 | 10.88 | | 7.86 | | | | |
| | 4 Wire Copper Unbundled Sub-Loop Distribution - Zone 3 | I | 3 | UEF | UCS4X | 19.40 | 102.31 | 56.32 | 65.24 | 10.88 | | 7.86 | | | | |
| | Order Coordination for Unbundled Sub-Loops, per sub-loop pair | | | UEF | USBMC | | 9.00 | 9.00 | | | | | | | | |
| | Unbundled Sub-Loop Modification | | | | | | | | | | | | | | | |
| | Unbundled Sub-Loop Modification - 2-W Copper Dist Load Coil/Equip Removal per 2-W PR | | | UEF | ULM2X | | 5.23 | 5.23 | | | | 7.86 | | | | |
| | Unbundled Sub-loop Modification - 4-W Copper Dist Load Coil/Equip Removal per 4-W PR | | | UEF | ULM4X | | 5.23 | 5.23 | | | | 7.86 | | | | |
| | Unbundled Sub-loop Modification - 2-w/4-w Copper Dist Bridged Tap Removal, per PR unloaded | | | UEF | ULM4T | | 7.97 | 7.97 | | | | 7.86 | | | | |
| | Unbundled Network Terminating Wire (UNTW) | | | | | | | | | | | | | | | |
| | Unbundled Network Terminating Wire (UNTW) per Pair | | | UENTW | UENPP | 0.53 | 23.51 | 23.51 | | | | 7.86 | | | | |
| | Network Interface Device (NID) | | | | | | | | | | | | | | | |
| | Network Interface Device (NID) - 1-2 lines | | | UENTW | UND12 | | 73.53 | 49.47 | | | | 7.86 | | | | |
| | Network Interface Device (NID) - 1-6 lines | | | UENTW | UND16 | | 115.96 | 91.91 | | | | 7.86 | | | | |
| | Network Interface Device Cross Connect - 2 W | | | UENTW | UNDC2 | | 8.56 | 8.56 | | | | 7.86 | | | | |
| | Network Interface Device Cross Connect - 4W | | | UENTW | UNDC4 | | 8.56 | 8.56 | | | | 7.86 | | | | |
| | SUB-LOOPS | | | | | | | | | | | | | | | |
| | Sub-Loop Feeder | | | | | | | | | | | | | | | |
| | USL-Feeder, DS0 Set-up per Cross Box location - CLEC Distribution Facility set-up | | | UEA, UDN,UCL,UDL,UDC | USBFW | | 207.91 | | | | | 7.86 | | | | |
| | USL Feeder - DS0 Set-up per Cross Box location - per 25 pair set-up | | | UEA, UDN,UCL,UDL,UDC | USBFX | | 12.50 | 12.50 | | | | 7.86 | | | | |
| | USL Feeder DS1 Set-up at DSX location, per DS1 termination | | | USL | USBFZ | | 527.98 | 11.32 | | | | 7.86 | | | | |
| | Unbundled Sub-Loop Feeder Loop, 2 Wire Ground Start, Voice Grade - Zone 1 | | 1 | UEA | USBFA | 7.67 | 114.83 | 64.61 | 72.34 | 17.21 | | 7.86 | | | | |
| | Unbundled Sub-Loop Feeder Loop, 2 Wire Ground-Start, Voice Grade - Zone 2 | | 2 | UEA | USBFA | 9.70 | 114.83 | 64.61 | 72.34 | 17.21 | | 7.86 | | | | |
| | Unbundled Sub-Loop Feeder Loop, Per 2 Wire Ground-Start, Voice Grade - Zone 3 | | 3 | UEA | USBFA | 19.53 | 114.83 | 64.61 | 72.34 | 17.21 | | 7.86 | | | | |
| | Order Coordination for Specified Conversion Time, per LSR | | | UEA | OCOSL | | 23.01 | | | | | | | | | |
| | Unbundled Sub-Loop Feeder Loop, 2 Wire Loop-Start, Voice Grade - Zone 1 | | 1 | UEA | USBFB | 7.67 | 114.83 | 64.61 | 72.34 | 17.21 | | 7.86 | | | | |
| | Unbundled Sub-Loop Feeder Loop, 2 Wire Loop-Start, Voice Grade - Zone 2 | | 2 | UEA | USBFB | 9.70 | 114.83 | 64.61 | 72.34 | 17.21 | | 7.86 | | | | |
| | Unbundled Sub-Loop Feeder Loop, 2 Wire Start Loop, Voice Grade - Zone 3 | | 3 | UEA | USBFB | 19.53 | 114.83 | 64.61 | 72.34 | 17.21 | | 7.86 | | | | |
| | Order Coordination for Specified Time Conversion, per LSR | | | UEA | OCOSL | | 23.01 | | | | | | | | | |

| UNBUNDLED NETWORK ELEMENTS - Kentucky | | | | | | | | | | | Attachment: 2 | | Exhibit: D | | | |
|---------------------------------------|---|---------|------|-------|-------|-----------|--------------|--------|-------------------------|----------------------------------|--------------------------------------|--|--|---|---|---------------|
| CATEGORY | RATE ELEMENTS | Interim | Zone | BCS | USOC | RATES(\$) | | | | Svc Order Submitted Elec per LSR | Svc Order Submitted Manually per LSR | Incremental Charge - Manual Svc Order vs. Electronic-1st | Incremental Charge - Manual Svc Order vs. Electronic-Add'l | Incremental Charge - Manual Svc Order vs. Electronic-Disc 1st | Incremental Charge - Manual Svc Order vs. Electronic-Disc Add'l | |
| | | | | | | Rec | Nonrecurring | | Nonrecurring Disconnect | | | | | | | OSS Rates(\$) |
| | | | | | | | First | Add'l | First | Add'l | SOMEc | SOMAN | SOMAN | SOMAN | SOMAN | SOMAN |
| | Unbundled Sub-Loop Feeder Loop, 2 Wire Reverse Battery, Voice Grade - Zone 1 | | 1 | UEA | USBFC | 7.67 | 114.83 | 64.61 | 72.34 | 17.21 | | 7.86 | | | | |
| | Unbundled Sub-Loop Feeder Loop, 2 Wire Reverse Battery, Voice Grade - Zone 2 | | 2 | UEA | USBFC | 9.70 | 114.83 | 64.61 | 72.34 | 17.21 | | 7.86 | | | | |
| | Unbundled Sub-Loop Feeder Loop, 2 Wire Analog Reverse Battery, Voice Grade - Zone 3 | | 3 | UEA | USBFC | 19.53 | 114.83 | 64.61 | 72.34 | 17.21 | | 7.86 | | | | |
| | Order Coordination For Specified Conversion Time, per LSR | | | UEA | OCOSL | | 23.01 | | | | | | | | | |
| | Unbundled Sub-Loop Feeder Loop, 4 Wire Ground-Start, Voice Grade - Zone 1 | | 1 | UEA | USBFD | 22.82 | 131.73 | 79.98 | 81.82 | 51.56 | | 7.86 | | | | |
| | Unbundled Sub-Loop Feeder Loop, 4 Wire Ground-Start, Voice Grade - Zone 2 | | 2 | UEA | USBFD | 27.24 | 131.73 | 79.98 | 81.82 | 51.56 | | 7.86 | | | | |
| | Unbundled Sub-Loop Feeder Loop, 4 Wire Ground Start, Voice Grade - Zone 3 | | 3 | UEA | USBFD | 61.41 | 131.73 | 79.98 | 81.82 | 51.56 | | 7.86 | | | | |
| | Order Coordination For Specified Conversion Time, Per LSR | | | UEA | OCOSL | | 23.01 | | | | | | | | | |
| | Unbundled Sub-Loop Feeder Loop, 4 Wire Loop-Start, Voice Grade - Zone 1 | | 1 | UEA | USBFE | 22.82 | 131.73 | 79.98 | 81.82 | 51.56 | | 7.86 | | | | |
| | Unbundled Sub-Loop Feeder Loop, 4 Wire Loop-Start, Voice Grade - Zone 2 | | 2 | UEA | USBFE | 27.24 | 131.73 | 79.98 | 81.82 | 51.56 | | 7.86 | | | | |
| | Unbundled Sub-Loop Feeder Loop, 4 Wire Loop-Start, Voice Grade - Zone 3 | | 3 | UEA | USBFE | 61.41 | 131.73 | 79.98 | 81.82 | 51.56 | | 7.86 | | | | |
| | Order Coordination For Specified Conversion Time, Per LSR | | | UEA | OCOSL | | 23.01 | | | | | | | | | |
| | Unbundled Sub-Loop Feeder Loop, 2 Wire ISDN BRI - Zone 1 | | 1 | UDN | USBFF | 13.00 | 131.79 | 80.04 | 74.16 | 16.60 | | 7.86 | | | | |
| | Unbundled Sub-Loop Feeder Loop, 2-Wire ISDN BRI - Zone 2 | | 2 | UDN | USBFF | 16.95 | 131.79 | 80.04 | 74.16 | 16.60 | | 7.86 | | | | |
| | Unbundled Sub-Loop Feeder Loop, 2-Wire ISDN BRI - Zone 3 | | 3 | UDN | USBFF | 28.95 | 131.79 | 80.04 | 74.16 | 16.60 | | 7.86 | | | | |
| | Order Coordination For Specified Conversion Time, Per LSR | | | UDN | OCOSL | | 23.01 | | | | | | | | | |
| | Unbundled Sub-Loop Feeder, 2 Wire UDC (IDSL compatible) | | 1 | UDC | USBFS | 13.00 | 131.79 | 80.04 | 74.16 | 16.60 | | 7.86 | | | | |
| | Unbundled Sub-Loop Feeder, 2 Wire UDC (IDSL compatible) | | 2 | UDC | USBFS | 16.95 | 131.79 | 80.04 | 74.16 | 16.60 | | 7.86 | | | | |
| | Unbundled Sub-Loop Feeder, 2 Wire UDC (IDSL compatible) | | 3 | UDC | USBFS | 28.95 | 131.79 | 80.04 | 74.16 | 16.60 | | 7.86 | | | | |
| | Unbundled Sub-Loop Feeder Loop, 4-Wire DS1 - Zone 1 | | 1 | USL | USBFG | 62.57 | 125.43 | 73.68 | 81.82 | 21.56 | | 7.86 | | | | |
| | Unbundled Sub-Loop Feeder Loop, 4-Wire DS1 - Zone 2 | | 2 | USL | USBFG | 87.71 | 125.43 | 73.68 | 81.82 | 21.56 | | 7.86 | | | | |
| | Unbundled Sub-Loop Feeder Loop, 4-Wire DS1 - Zone 3 | | 3 | USL | USBFG | 273.33 | 125.43 | 73.68 | 81.82 | 21.56 | | 7.86 | | | | |
| | Order Coordination For Specified Conversion Time, Per LSR | | | USL | OCOSL | | 23.01 | | | | | | | | | |
| | Unbundled Sub-Loop Feeder, 2-Wire Copper Loop - Zone 1 | | 1 | UCL | USBFH | 6.44 | 105.31 | 53.57 | 71.16 | 13.61 | | 7.86 | | | | |
| | Unbundled Sub-Loop Feeder Loop, 2-Wire Copper Loop - Zone 2 | | 2 | UCL | USBFH | 5.78 | 105.31 | 53.57 | 71.16 | 13.61 | | 7.86 | | | | |
| | Unbundled Sub-Loop Feeder Loop, 2-Wire Copper Loop - Zone 3 | | 3 | UCL | USBFH | 4.25 | 105.31 | 53.57 | 71.16 | 13.61 | | 7.86 | | | | |
| | Order Coordination For Specified Conversion Time, per LSR | | | UCL | OCOSL | | 23.01 | | | | | | | | | |
| | Sub-Loop Feeder - Per 4-Wire Copper Loop - Zone 1 | | 1 | UCL | USBFJ | 11.33 | 125.55 | 73.80 | 77.12 | 16.86 | | 7.86 | | | | |
| | Sub-Loop Feeder - Per 4-Wire Copper Loop - Zone 2 | | 2 | UCL | USBFJ | 10.18 | 125.55 | 73.80 | 77.12 | 16.86 | | 7.86 | | | | |
| | Sub-Loop Feeder - Per 4-Wire Copper Loop - Zone 3 | | 3 | UCL | USBFJ | 10.32 | 125.55 | 73.80 | 77.12 | 16.86 | | 7.86 | | | | |
| | Order Coordination For Specified Conversion Time, per LSR | | | UCL | OCOSL | | 23.01 | | | | | | | | | |
| | Sub-Loop Feeder - Per 4-Wire 19.2 Kbps Digital Grade Loop | | 1 | UDL | USBFN | 20.78 | 125.43 | 73.68 | 81.82 | 21.56 | | 7.86 | | | | |
| | Sub-Loop Feeder - Per 4-Wire 19.2 Kbps Digital Grade Loop | | 2 | UDL | USBFN | 26.41 | 125.43 | 73.68 | 81.82 | 21.56 | | 7.86 | | | | |
| | Sub-Loop Feeder - Per 4-Wire 19.2 Kbps Digital Grade Loop | | 3 | UDL | USBFN | 23.10 | 125.43 | 73.68 | 81.82 | 21.56 | | 7.86 | | | | |
| | Sub-Loop Feeder - Per 4-Wire 56 Kbps Digital Grade Loop - Zone 1 | | 1 | UDL | USBFO | 20.78 | 125.43 | 73.68 | 81.82 | 21.56 | | 7.86 | | | | |
| | Sub-Loop Feeder - Per 4-Wire 56 Kbps Digital Grade Loop - Zone 2 | | 2 | UDL | USBFO | 26.41 | 125.43 | 73.68 | 81.82 | 21.56 | | 7.86 | | | | |
| | Sub-Loop Feeder - Per 4-Wire 56 Kbps Digital Grade Loop - Zone 3 | | 3 | UDL | USBFO | 23.10 | 125.43 | 73.68 | 81.82 | 21.56 | | 7.86 | | | | |
| | Order Coordination For Specified Time Conversion, per LSR | | | UDL | OCOSL | | 23.01 | | | | | | | | | |
| | Sub-Loop Feeder - Per 4-Wire 64 Kbps Digital Grade Loop - Zone 1 | | 1 | UDL | USBFP | 20.78 | 125.43 | 73.68 | 81.82 | 21.56 | | 7.86 | | | | |
| | Sub-Loop Feeder - Per 4-Wire 64 Kbps Digital Grade Loop - Zone 2 | | 2 | UDL | USBFP | 26.41 | 125.43 | 73.68 | 81.82 | 21.56 | | 7.86 | | | | |
| | Sub-Loop Feeder - Per 4-Wire 64 Kbps Digital Grade Loop - Zone 3 | | 3 | UDL | USBFP | 23.10 | 125.43 | 73.68 | 81.82 | 21.56 | | 7.86 | | | | |
| | Order Coordination For Specified Conversion Time, per LSR | | | UDL | OCOSL | | 23.01 | | | | | | | | | |
| SUB-LOOPS | | | | | | | | | | | | | | | | |
| | Sub-Loop Feeder | | | | | | | | | | | | | | | |
| | Sub Loop Feeder - DS3 - Per Mile Per Month | | I | UE3 | 1L5SL | 15.38 | | | | | | | | | | |
| | Sub Loop Feeder - DS3 - Facility Termination Per Month | | I | UE3 | USBF1 | 346.30 | 3,402.59 | 407.14 | 160.86 | 91.19 | | 7.86 | | | | |
| | Sub Loop Feeder - STS-1 - Per Mile Per Month | | I | UDLSX | 1L5SL | 15.38 | | | | | | | | | | |

| UNBUNDLED NETWORK ELEMENTS - Kentucky | | | | | | | | | | Attachment: 2 | | Exhibit: D | | | | |
|---|---|---------|------|---------------------------------|-------|-----------|--------------------|--------------------|-------------------------------|----------------------------------|--------------------------------------|--|--|---|---|-------------------------------|
| CATEGORY | RATE ELEMENTS | Interim | Zone | BCS | USOC | RATES(\$) | | | | Svc Order Submitted Elec per LSR | Svc Order Submitted Manually per LSR | Incremental Charge - Manual Svc Order vs. Electronic-1st | Incremental Charge - Manual Svc Order vs. Electronic-Add'l | Incremental Charge - Manual Svc Order vs. Electronic-Disc 1st | Incremental Charge - Manual Svc Order vs. Electronic-Disc Add'l | |
| | | | | | | Rec | Nonrecurring First | Nonrecurring Add'l | Nonrecurring Disconnect First | | | | | | | Nonrecurring Disconnect Add'l |
| | | | | | | | | | | | SOMEc | SOMAN | SOMAN | SOMAN | SOMAN | SOMAN |
| | Sub Loop Feeder - STS-1 - Facility Termination Per Month | I | | UDLSX | USBF7 | 372.80 | 3,402.59 | 407.14 | 160.86 | 91.19 | | 7.86 | | | | |
| | Sub Loop Feeder - OC-3 - Per Mile Per Month | I | | UDLO3 | 1L5SL | 11.67 | | | | | | | | | | |
| | Sub Loop Feeder - OC-3 - Facility Termination Protection Per Month | I | | UDLO3 | USBF5 | 58.27 | | | | | | | | | | |
| | Sub Loop Feeder - OC-3 - Facility Termination Per Month | I | | UDLO3 | USBF2 | 564.68 | 3,402.59 | 407.14 | 160.86 | 91.19 | | 7.86 | | | | |
| | Sub Loop Feeder - OC-12 - Per Mile Per Month | I | | UDL12 | 1L5SL | 14.36 | | | | | | | | | | |
| | Sub Loop Feeder - OC-12 - Facility Termination Protection Per Month | I | | UDL12 | USBF6 | 658.35 | | | | | | | | | | |
| | Sub Loop Feeder - OC-12 - Facility Termination Per Month | I | | UDL12 | USBF3 | 1,778.00 | 3,402.59 | 407.14 | 160.86 | 91.19 | | 7.86 | | | | |
| | Sub Loop Feeder - OC-48 - Per Mile Per Month | I | | UDL48 | 1L5SL | 47.11 | | | | | | | | | | |
| | Sub Loop Feeder - OC-48 - Facility Termination Protection Per Month | I | | UDL48 | USBF9 | 330.39 | | | | | | | | | | |
| | Sub Loop Feeder - OC-48 - Facility Termination Per Month | I | | UDL48 | USBF4 | 1,533.00 | 3,587.59 | 407.14 | 160.86 | 91.19 | | 7.86 | | | | |
| | Sub Loop Feeder - OC-12 Interface On OC-48 | I | | UDL48 | USBF8 | 372.76 | 804.96 | 407.14 | 160.86 | 91.19 | | 7.86 | | | | |
| UNBUNDLED LOOP CONCENTRATION | | | | | | | | | | | | | | | | |
| | Unbundled Loop Concentration - System A (TR008) | | | ULC | UCT8A | 423.72 | 359.34 | 359.34 | | | | 7.86 | | | | |
| | Unbundled Loop Concentration - System B (TR008) | | | ULC | UCT8B | 51.60 | 149.72 | 149.72 | | | | 7.86 | | | | |
| | Unbundled Loop Concentration - System A (TR303) | | | ULC | UCT3A | 460.27 | 359.34 | 359.34 | | | | 7.86 | | | | |
| | Unbundled Loop Concentration - System B (TR303) | | | ULC | UCT3B | 86.95 | 149.72 | 149.72 | | | | 7.86 | | | | |
| | Unbundled Loop Concentration - DS1 Loop Interface Card | | | ULC | UCTCO | 4.90 | 71.69 | 51.51 | 22.99 | 6.00 | | 7.86 | | | | |
| | Unbundled Loop Concentration - ISDN Loop Interface (Brite Card) | | | UDN | ULCC1 | 7.78 | 16.59 | 16.50 | 8.42 | 8.37 | | 7.86 | | | | |
| | Unbundled Loop Concentration - UDC Loop Interface (Brite Card) | | | UDC | ULCCU | 7.78 | 16.59 | 16.50 | 8.42 | 8.37 | | 7.86 | | | | |
| | Unbundled Loop Concentration - 2 Wire Voice-Loop Start or Ground Start Loop Interface (POTS Card) | | | UEA | ULCC2 | 1.95 | 16.59 | 16.50 | 8.42 | 8.37 | | 7.86 | | | | |
| | Unbundled Loop Concentration - 2 Wire Voice - Reverse Battery Loop Interface (SPOTS Card) | | | UEA | ULCCR | 11.58 | 16.59 | 16.50 | 8.42 | 8.37 | | 7.86 | | | | |
| | Unbundled Loop Concentration - 4 Wire Voice Loop Interface (Specials Card) | | | UEA | ULCC4 | 6.90 | 16.59 | 16.50 | 8.42 | 8.37 | | 7.86 | | | | |
| | Unbundled Loop Concentration - TEST CIRCUIT Card | | | ULC | UCTTC | 33.74 | 16.59 | 16.50 | 8.42 | 8.37 | | 7.86 | | | | |
| | Unbundled Loop Concentration - Digital 19.2 Kbps Data Loop Interface | | | UDL | ULCC7 | 10.23 | 16.59 | 16.50 | 8.42 | 8.37 | | 7.86 | | | | |
| | Unbundled Loop Concentration - Digital 56 Kbps Data Loop Interface | | | UDL | ULCC5 | 10.23 | 16.59 | 16.50 | 8.42 | 8.37 | | 7.86 | | | | |
| | Unbundled Loop Concentration - Digital 64 Kbps Data Loop Interface | | | UDL | ULCC6 | 10.23 | 16.59 | 16.50 | 8.42 | 8.37 | | 7.86 | | | | |
| UNE OTHER, PROVISIONING ONLY - NO RATE | | | | | | | | | | | | | | | | |
| | NID - Dispatch and Service Order for NID installation | | | UENTW | UNDBX | 0.00 | 0.00 | | | | | | | | | |
| | UNTW Circuit Id Establishment, Provisioning Only - No Rate | | | UENTW | UENCE | 0.00 | 0.00 | | | | | | | | | |
| | Unbundled Contract Name, Provisioning Only - No Rate | | | UEANL,UEF,UEQ,UENTW | UNECN | 0.00 | 0.00 | | | | | | | | | |
| UNE OTHER, PROVISIONING ONLY - NO RATE | | | | | | | | | | | | | | | | |
| | Unbundled Contact Name, Provisioning Only - no rate | | | UAL,UCL,UDC,UDL,UDN,UEA,UHL,UCL | UNECN | 0.00 | 0.00 | | | | | | | | | |
| | Unbundled Sub-Loop Feeder-2 Wire Cross Box Jumper - no rate | | | UEA,UDN,UCL,UDC | USBFQ | 0.00 | 0.00 | | | | | | | | | |
| | Unbundled Sub-Loop Feeder-4 Wire Cross Box Jumper - no rate | | | UEA,USL,UCL,UDL | USBFR | 0.00 | 0.00 | | | | | | | | | |
| | Unbundled DS1 Loop - Superframe Format Option - no rate | | | USL | CCOSF | 0.00 | 0.00 | | | | | | | | | |
| | Unbundled DS1 Loop - Expanded Superframe Format option - no rate | | | USL | CCOEF | 0.00 | 0.00 | | | | | | | | | |
| HIGH CAPACITY UNBUNDLED LOCAL LOOP | | | | | | | | | | | | | | | | |
| | High Capacity Unbundled Local Loop - DS3 - Per Mile per month | | | UE3 | 1L5ND | 9.25 | | | | | | | | | | |
| | High Capacity Unbundled Local Loop - DS3 - Facility Termination per month | | | UE3 | UE3PX | 308.31 | 551.38 | 338.08 | 173.00 | 120.42 | | 7.86 | | | | |
| | High Capacity Unbundled Local Loop - STS-1 - Per Mile per month | | | UDLSX | 1L5ND | 9.25 | | | | | | | | | | |
| | High Capacity Unbundled Local Loop - STS-1 - Facility Termination per month | | | UDLSX | UDLS1 | 320.51 | 551.38 | 338.08 | 173.00 | 120.42 | | 7.86 | | | | |
| LOOP MAKE-UP | | | | | | | | | | | | | | | | |

| UNBUNDLED NETWORK ELEMENTS - Kentucky | | | | | | | | | | Attachment: 2 | | Exhibit: D | | | |
|--|--|---------|------|-------|-------|-----------|--------------|-------|-------------------------|----------------------------------|--------------------------------------|--|--|---|---|
| CATEGORY | RATE ELEMENTS | Interim | Zone | BCS | USOC | RATES(\$) | | | | Svc Order Submitted Elec per LSR | Svc Order Submitted Manually per LSR | Incremental Charge - Manual Svc Order vs. Electronic-1st | Incremental Charge - Manual Svc Order vs. Electronic-Add'l | Incremental Charge - Manual Svc Order vs. Electronic-Disc 1st | Incremental Charge - Manual Svc Order vs. Electronic-Disc Add'l |
| | | | | | | Rec | Nonrecurring | | Nonrecurring Disconnect | | | | | | |
| | | | | | | First | Add'l | First | Add'l | SOMEK | SOMAN | SOMAN | SOMAN | SOMAN | SOMAN |
| | Loop Makeup - Preordering Without Reservation, per working or spare facility queried (Manual). | | | UMK | UMKLV | 23.40 | 23.40 | | | | | | | | |
| | Loop Makeup - Preordering With Reservation, per spare facility queried (Manual). | | | UMK | UMKLP | 24.85 | 24.85 | | | | | | | | |
| | Loop Makeup--With or Without Reservation, per working or spare facility queried (Mechanized) | | | UMK | PSUMK | 0.67 | 0.67 | | | | | | | | |
| HIGH FREQUENCY SPECTRUM | | | | | | | | | | | | | | | |
| LINE SHARING | | | | | | | | | | | | | | | |
| SPLITTERS-CENTRAL OFFICE BASED | | | | | | | | | | | | | | | |
| | Line Sharing Splitter, per System 96 Line Capacity | | | ULS | ULSDA | 198.83 | 379.05 | 0.00 | 358.55 | 0.00 | | | | | 7.86 |
| | Line Sharing Splitter, per System 24 Line Capacity | | | ULS | ULSDB | 49.71 | 379.05 | 0.00 | 358.55 | 0.00 | | | | | 7.86 |
| | Line Sharing Splitter, Per System, 8 Line Capacity | I | | ULS | ULSD8 | 16.94 | 377.71 | 0.00 | 357.29 | 0.00 | | | | | 7.86 |
| | Line Sharing-DLEC Owned Splitter in CO-CFA activator-deactivation (per LSOD) | | | ULS | ULSDG | | 173.62 | 0.00 | 100.40 | 0.00 | | | | | 7.86 |
| END USER ORDERING-CENTRAL OFFICE BASED-HIGH FREQUENCY SPECTRUM AKA LINE SHARING | | | | | | | | | | | | | | | |
| | Line Sharing - per Line Activation (BST Owned Splitter) | | | ULS | ULSDC | 0.61 | 37.16 | 21.28 | 20.17 | 9.90 | | | | | 7.86 |
| | Line Sharing - per Subsequent Activity per Line Rearrangement(BST Owned Splitter) | | | ULS | ULSDS | | 32.90 | 16.43 | | | | | | | 7.86 |
| | Line Sharing - per Subsequent Activity per Line Rearrangement(DLEC Owned Splitter) | | | ULS | ULSCS | | 32.90 | 16.43 | | | | | | | 7.86 |
| | Line Sharing - per Line Activation (DLEC owned Splitter) | I | | ULS | ULSCC | 0.61 | 47.44 | 19.31 | 20.67 | 12.74 | | | | | 7.86 |
| LINE SPLITTING | | | | | | | | | | | | | | | |
| END USER ORDERING-CENTRAL OFFICE BASED | | | | | | | | | | | | | | | |
| | Line Splitting - per line activation DLEC owned splitter | I | | UEPSR | UEPSB | 0.61 | | | | | | | | | |
| | Line Splitting - per line activation BST owned - physical | I | | UEPSR | UEPSB | 0.61 | 37.02 | 21.20 | 21.10 | 9.87 | | | | | 7.86 |
| | Line Splitting - per line activation BST owned - virtual | I | | UEPSR | UEPSB | 0.61 | 37.02 | 21.20 | 21.10 | 9.87 | | | | | 7.86 |
| REMOTE SITE HIGH FREQUENCY SPECTRUM | | | | | | | | | | | | | | | |
| SPLITTERS-REMOTE SITE | | | | | | | | | | | | | | | |
| | Remote Site Line Share BellSouth Owned Splitter, 24 Port | I | | ULS | ULSRB | 50.83 | 377.71 | 0.00 | 357.29 | 0.00 | | | | | 7.86 |
| | Remote Site Line Share Cable Pair Activation CLEC Owned at RS and Deactivation | I | | ULS | ULSTG | | 74.38 | 0.00 | 46.77 | 0.00 | | | | | 7.86 |
| END USER ORDERING-REMOTE SITE HIGH FREQUENCY SPECTRUM AKA REMOTE SITE LINE SHARING | | | | | | | | | | | | | | | |
| | Remote Site Line Share Line Activationfor End User Served at RS, BST Splitter | I | | ULS | ULSRC | 0.61 | 37.16 | 21.28 | 20.17 | 9.90 | | | | | 7.86 |
| | RS Line Share Line Activation for End User served at RS, CLEC Splitter | I | | ULS | ULSTC | 0.61 | 37.16 | 21.28 | 20.17 | 9.90 | | | | | 7.86 |
| UNBUNDLED DEDICATED TRANSPORT | | | | | | | | | | | | | | | |
| NOTE: INTEROFFICE CHANNEL DEDICATED TRANSPORT - minimum billing period - below DS3=one month, DS3/STS-1=four months | | | | | | | | | | | | | | | |
| INTEROFFICE CHANNEL - DEDICATED TRANSPORT | | | | | | | | | | | | | | | |
| | Interoffice Channel - Dedicated Transport - 2-Wire Voice Grade - Per Mile per month | | | U1TVX | 1L5XX | 0.01 | | | | | | | | | |
| | Interoffice Channel - Dedicated Transport- 2- Wire Voice Grade - Facility Termination | | | U1TVX | U1TV2 | 29.11 | 47.34 | 31.78 | 22.77 | 8.75 | | | | | 7.86 |
| | Interoffice Channel - Dedicated Transport - 2-Wire Voice Grade Rev Bat. - Per Mile per month | | | U1TVX | 1L5XX | 0.01 | | | | | | | | | |
| | Interoffice Channel - Dedicated Transport- 2- Wire VG Rev Bat. - Facility Termination | | | U1TVX | U1TR2 | 29.11 | 47.34 | 31.78 | 22.77 | 8.75 | | | | | 7.86 |
| | Interoffice Channel - Dedicated Transport - 4-Wire Voice Grade - Per Mile per month | | | U1TVX | 1L5XX | 0.01 | | | | | | | | | |
| | Interoffice Channel - Dedicated Transport - 4- Wire Voice Grade - Facility Termination | | | U1TVX | U1TV4 | 25.86 | 47.34 | 31.78 | 22.77 | 8.75 | | | | | 7.86 |
| | Interoffice Channel - Dedicated Transport - 56 kbps - per mile per month | | | U1TDX | 1L5XX | 0.0115 | | | | | | | | | |
| | Interoffice Channel - Dedicated Transport - 56 kbps - Facility Termination | | | U1TDX | U1TD5 | 20.97 | 47.35 | 31.78 | 22.77 | 8.75 | | | | | 7.86 |
| | Interoffice Channel - Dedicated Transport - 64 kbps - per mile per month | | | U1TDX | 1L5XX | 0.0115 | | | | | | | | | |
| | Interoffice Channel - Dedicated Transport - 64 kbps - Facility Termination | | | U1TDX | U1TD6 | 20.97 | 47.35 | 31.78 | 22.77 | 8.75 | | | | | 7.86 |
| | Interoffice Channel - Dedicated Channel - DS1 - Per Mile per month | | | U1TD1 | 1L5XX | 0.23 | | | | | | | | | |
| | Interoffice Channel - Dedicated Transport - DS1 - Facility Termination | | | U1TD1 | U1TF1 | 96.04 | 105.52 | 98.46 | 23.09 | 20.49 | | | | | 7.86 |

| UNBUNDLED NETWORK ELEMENTS - Kentucky | | | | | | | | | | Attachment: 2 | | Exhibit: D | | | |
|--|--|---------|------|----------|-------|-----------|--------------|--------|-------------------------|----------------------------------|--------------------------------------|--|--|---|---|
| CATEGORY | RATE ELEMENTS | Interim | Zone | BCS | USOC | RATES(\$) | | | | Svc Order Submitted Elec per LSR | Svc Order Submitted Manually per LSR | Incremental Charge - Manual Svc Order vs. Electronic-1st | Incremental Charge - Manual Svc Order vs. Electronic-Add'l | Incremental Charge - Manual Svc Order vs. Electronic-Disc 1st | Incremental Charge - Manual Svc Order vs. Electronic-Disc Add'l |
| | | | | | | Rec | Nonrecurring | | Nonrecurring Disconnect | | | | | | |
| | | | | | | First | Add'l | First | Add'l | SOMEc | SOMAN | SOMAN | SOMAN | SOMAN | SOMAN |
| | Interoffice Channel - Dedicated Transport - DS3 - Per Mile per month | | | U1TD3 | 1L5XX | 4.97 | | | | | | | | | |
| | Interoffice Channel - Dedicated Transport - DS3 - Facility Termination per month | | | U1TD3 | U1TF3 | 1,175.15 | 335.40 | 219.24 | 89.57 | 87.75 | | 7.86 | | | |
| | Interoffice Channel - Dedicated Transport - STS-1 - Per Mile per month | | | U1TS1 | 1L5XX | 4.97 | | | | | | | | | |
| | Interoffice Channel - Dedicated Transport - STS-1 - Facility Termination | | | U1TS1 | U1TFS | 1,149.51 | 335.40 | 219.24 | 89.57 | 87.75 | | 7.86 | | | |
| LOCAL CHANNEL - DEDICATED TRANSPORT | | | | | | | | | | | | | | | |
| NOTE: LOCAL CHANNEL DEDICATED TRANSPORT - minimum billing period - below DS3=one month, DS3/STS-1=four months | | | | | | | | | | | | | | | |
| | Local Channel - Dedicated - 2-Wire Voice Grade | | | ULDVX | ULDV2 | 18.57 | 265.78 | 46.96 | 46.79 | 4.98 | | 7.86 | | | |
| | Local Channel - Dedicated - 2-Wire Voice Grade Rev Bat | | | ULDVX | ULDR2 | 18.57 | 265.78 | 46.96 | 46.79 | 4.98 | | 7.86 | | | |
| | Local Channel - Dedicated - 4-Wire Voice Grade | | | UNDVX | ULDV4 | 19.86 | 266.48 | 47.65 | 47.54 | 5.73 | | 7.86 | | | |
| | Local Channel - Dedicated - DS1 - Zone 1 | | 1 | ULDD1 | ULDF1 | 40.46 | 209.60 | 176.51 | 30.21 | 21.07 | | 7.86 | | | |
| | Local Channel - Dedicated - DS1 - Zone 2 | | 2 | ULDD1 | ULDF1 | 43.39 | 209.60 | 176.51 | 30.21 | 21.07 | | 7.86 | | | |
| | Local Channel - Dedicated - DS1 - Zone 3 | | 3 | ULDD1 | ULDF1 | 164.50 | 209.60 | 176.51 | 30.21 | 21.07 | | 7.86 | | | |
| | Local Channel - Dedicated - DS3 - Per Mile per month | | | ULDD3 | 1L5NC | 8.74 | | | | | | | | | |
| | Local Channel - Dedicated - DS3 - Facility Termination | | | ULDD3 | ULDF3 | 576.05 | 551.38 | 338.08 | 173.00 | 120.42 | | 7.86 | | | |
| | Local Channel - Dedicated - STS-1 - Per Mile per month | | | ULDS1 | 1L5NC | 8.74 | | | | | | | | | |
| | Local Channel - Dedicated - STS-1 - Facility Termination | | | ULDS1 | ULDFS | 543.24 | 551.38 | 338.08 | 173.00 | 120.42 | | 7.86 | | | |
| DARK FIBER | | | | | | | | | | | | | | | |
| | Dark Fiber, Four Fiber Strands, Per Route Mile or Fraction Thereof per month - Local Channel | | | UDF | 1L5DC | 47.01 | | | | | | | | | |
| | NRC Dark Fiber - Local Channel | | | UDF | UDFC4 | | 732.53 | 192.67 | 377.27 | 241.67 | | 7.86 | | | |
| | Dark Fiber, Four Fiber Strands, Per Route Mile or Fraction Thereof per month - Interoffice Channel | | | UDF | 1L5DF | 30.74 | | | | | | | | | |
| | NRC Dark Fiber - Interoffice Channel | | | UDF | UDF14 | | 732.53 | 192.67 | 377.27 | 241.67 | | 7.86 | | | |
| | Dark Fiber, Four Fiber Strands, Per Route Mile or Fraction Thereof per month - Local Loop | | | UDF | 1L5DL | 47.01 | | | | | | | | | |
| | NRC Dark Fiber - Local Loop | | | UDF | UDFL4 | | 732.53 | 192.67 | 377.27 | 241.67 | | 7.86 | | | |
| 8XX ACCESS TEN DIGIT SCREENING | | | | | | | | | | | | | | | |
| | 8XX Access Ten Digit Screening, Per Call | | | OHD | | 0.0006478 | | | | | | | | | |
| | 8XX Access Ten Digit Screening, Reservation Charge Per 8XX Number Reserved | | | OHD | N8R1X | | 4.14 | 0.70 | | | | 7.86 | | | |
| | 8XX Access Ten Digit Screening, Per 8XX No. Established W/O POTS Translations | | | OHD | | | 8.78 | 1.18 | 7.08 | 0.86 | | 7.86 | | | |
| | 8XX Access Ten Digit Screening, Per 8XX No. Established With POTS Translations | | | OHD | N8FTX | | 8.78 | 1.18 | 7.08 | 0.86 | | 7.86 | | | |
| | 8XX Access Ten Digit Screening, Customized Area of Service Per 8XX Number | | | OHD | N8FCX | | 4.14 | 2.07 | | | | 7.86 | | | |
| | 8XX Access Ten Digit Screening, Multiple InterLATA CXR Routing Per CXR Requested Per 8XX No. | | | OHD | N8FMX | | 4.85 | 2.78 | | | | 7.86 | | | |
| | 8XX Access Ten Digit Screening, Change Charge Per Request | | | OHD | N8FAX | | 4.85 | 0.70 | | | | 7.86 | | | |
| | 8XX Access Ten Digit Screening, Call Handling and Destination Features | | | OHD | N8FDX | | 4.14 | 4.14 | | | | 7.86 | | | |
| | 8XX Access Ten Digit Screening w/ 8FL No. Delivery, | | | OHD | | 0.0006478 | | | | | | | | | |
| | 8XX Access Ten Digit Screening, w/ POTS No. Delivery, | | | OHD | | 0.0006478 | | | | | | | | | |
| LINE INFORMATION DATA BASE ACCESS (LIDB) | | | | | | | | | | | | | | | |
| | LIDB Common Transport Per Query | | | OQT | | 0.000023 | | | | | | | | | |
| | LIDB Validation Per Query | | | OQU | | 0.0137322 | | | | | | | | | |
| | LIDB Originating Point Code Establishment or Change | | | OQT, OQU | NRPBX | | 55.12 | | 67.59 | | | 7.86 | | | |
| SIGNALING (CCS7) | | | | | | | | | | | | | | | |
| | CCS7 Signaling Connection, Per 56 Kbps Facility | | | UDB | TPP++ | 20.71 | 43.56 | 43.56 | 22.45 | 22.45 | | | | | |
| | CCS7 Signaling Termination, Per STP Port | | | UDB | PT8SX | 151.39 | | | | | | | | | |
| | CCS7 Signaling Usage, Per TCAP Message | | | UDB | | 0.0000656 | | | | | | | | | |
| | CCS7 Signaling Connection, Per link (A link) | | | UDB | TPP++ | 20.71 | 43.56 | 43.56 | 22.45 | 22.45 | | 7.86 | | | |
| | CCS7 Signaling Connection, Per link (B link) (also known as D link) | | | UDB | TPP++ | 20.71 | 43.56 | 43.56 | 22.45 | 22.45 | | 7.86 | | | |
| | CCS7 Signaling Usage, Per ISUP Message | | | UDB | | 0.0000164 | | | | | | | | | |
| | CCS7 Signaling Usage Surrogate, per link per LATA | | | UDB | STU56 | 751.08 | | | | | | | | | |
| | CCS7 Signaling Point Code, per Originating Point Code Establishment or Change, per STP affected | | | UDB | CCAPO | | 46.02 | 46.02 | 56.43 | 56.43 | | 7.86 | | | |
| | CCS7 Signaling Point Code, per Destination Point Code Establishment or Change, Per Stp Affected | | | UDB | CCAPD | | 46.02 | 46.02 | 56.43 | 56.43 | | 7.86 | | | |

| UNBUNDLED NETWORK ELEMENTS - Kentucky | | | | | | | | | | Attachment: 2 | | Exhibit: D | | | |
|--|--|---------|------|-----|-------|-----------|--------------|--------|-------------------------|----------------------------------|--------------------------------------|--|--|---|---|
| CATEGORY | RATE ELEMENTS | Interim | Zone | BCS | USOC | RATES(\$) | | | | Svc Order Submitted Elec per LSR | Svc Order Submitted Manually per LSR | Incremental Charge - Manual Svc Order vs. Electronic-1st | Incremental Charge - Manual Svc Order vs. Electronic-Add'l | Incremental Charge - Manual Svc Order vs. Electronic-Disc 1st | Incremental Charge - Manual Svc Order vs. Electronic-Disc Add'l |
| | | | | | | Rec | Nonrecurring | | Nonrecurring Disconnect | | | | | | |
| | | | | | | First | Add'l | First | Add'l | SOMEc | SOMAN | SOMAN | SOMAN | SOMAN | SOMAN |
| E911 SERVICE | | | | | | | | | | | | | | | |
| | Local Channel - Dedicated - 2-wr Voice Grade | | | | | 18.57 | 265.78 | 46.96 | 46.79 | 4.98 | | 7.86 | | | |
| | Interoffice Transport - Dedicated - 2-wr Voice Grade Per Mile | | | | | 0.0115 | | | | | | | | | |
| | Interoffice Transport - Dedicated - 2-wr Voice Grade Per Facility Termination | | | | | 29.11 | 47.34 | 31.78 | 22.77 | 8.75 | | 7.86 | | | |
| | Local Channel - Dedicated - DS1 - Zone 1 | | | | | 40.46 | 209.60 | 176.51 | 30.21 | 21.07 | | 7.86 | | | |
| | Local Channel - Dedicated - DS1 - Zone 2 | | | | | 43.39 | 209.60 | 176.51 | 30.21 | 21.07 | | 7.86 | | | |
| | Local Channel - Dedicated - DS1 - Zone 3 | | | | | 164.50 | 209.60 | 176.51 | 30.21 | 21.07 | | 7.86 | | | |
| | Interoffice Transport - Dedicated - DS1 Per Mile | | | | | 0.23 | | | | | | | | | |
| | Interoffice Transport - Dedicated - DS1 Per Facility Termination | | | | | 96.04 | 105.52 | 98.46 | 23.09 | 20.49 | | 7.86 | | | |
| CALLING NAME (CNAM) SERVICE | | | | | | | | | | | | | | | |
| | CNAM For DB Owners - Service Establishment | | | OQV | | 25.34 | 25.34 | 23.30 | 23.30 | | 7.86 | | | | |
| | CNAM For Non DB Owners - Service Establishment | | | OQV | | 25.34 | 25.34 | 23.30 | 23.30 | | 7.86 | | | | |
| | CNAM For DB Owners - Service Provisioning With Point Code Establishment | | | OQV | | 1,591.54 | 1,177.08 | 431.95 | 317.61 | | 7.86 | | | | |
| | CNAM For Non DB Owners - Service Provisioning With Point Code Establishment | | | OQV | | 546.40 | 393.74 | 438.93 | 317.61 | | 7.86 | | | | |
| | CNAM for DB Owners, Per Query | | | OQV | | 0.0010348 | | | | | | | | | |
| | CNAM for Non DB Owners, Per Query | | | OQV | | 0.0010348 | | | | | | | | | |
| | CNAM (Non-Databs Owner), NRC, applies when using the Character Based User Interface (CHUI) | | | OQV | CDDCH | 595.00 | 595.00 | | | | 7.86 | | | | |
| LNP Query Service | | | | | | | | | | | | | | | |
| | LNP Charge Per query | | | | | 0.0008695 | | | | | | | | | |
| | LNP Service Establishment Manual | | | | | 13.82 | 13.82 | 12.71 | 12.71 | | 7.86 | | | | |
| | LNP Service Provisioning with Point Code Establishment | | | | | 953.27 | 487.00 | 431.95 | 317.61 | | 7.86 | | | | |
| OPERATOR CALL PROCESSING | | | | | | | | | | | | | | | |
| | Oper. Call Processing - Oper. Provided, Per Min. - Using BST LIDB | | | | | 1.20 | | | | | | | | | |
| | Oper. Call Processing - Oper. Provided, Per Min. - Using Foreign LIDB | | | | | 1.24 | | | | | | | | | |
| | Oper. Call Processing - Fully Automated, per Call - Using BST LIDB | | | | | 0.20 | | | | | | | | | |
| | Oper. Call Processing - Fully Automated, per Call - Using Foreign LIDB | | | | | 0.20 | | | | | | | | | |
| INWARD OPERATOR SERVICES | | | | | | | | | | | | | | | |
| | Inward Operator Services - Verification, Per Call | | | | | 1.00 | | | | | | | | | |
| | Inward Operator Services - Verification and Emergency Interrupt - Per Call | | | | | 1.95 | | | | | | | | | |
| BRANDING - OPERATOR CALL PROCESSING | | | | | | | | | | | | | | | |
| | Facility based CLEC | | | | | | | | | | | | | | |
| | Recording of Custom Branded OA Announcement | | | | CBAOS | 7,000.00 | 7,000.00 | | | | 7.86 | | | | |
| | Loading of Custom Branded OA Announcement per shelf/NAV per OCN | | | | CBAOL | 500.00 | 500.00 | | | | 7.86 | | | | |
| | UNEP CLEC | | | | | | | | | | | | | | |
| | Recording of Custom Branded OA Announcement | | | | | 7,000.00 | 7,000.00 | | | | 7.86 | | | | |
| | Loading of Custom Branded OA Announcement per shelf/NAV per OCN | | | | | 500.00 | 500.00 | | | | 7.86 | | | | |
| | Unbranding via OLS for UNEP CLEC | | | | | | | | | | | | | | |
| | Loading of OA per OCN (Regional) | | | | | 1,200.00 | 1,200.00 | | | | 7.86 | | | | |
| DIRECTORY ASSISTANCE SERVICES | | | | | | | | | | | | | | | |
| | DIRECTORY ASSISTANCE ACCESS SERVICE | | | | | | | | | | | | | | |
| | Directory Assistance Access Service Calls, Charge Per Call | | | | | 0.275 | | | | | | | | | |
| | DIRECTORY ASSISTANCE CALL COMPLETION ACCESS SERVICE (DACC) | | | | | | | | | | | | | | |
| | Directory Assistance Call Completion Access Service (DACC), Per Call Attempt | | | | | 0.10 | | | | | | | | | |
| DIRECTORY ASSISTANCE SERVICES | | | | | | | | | | | | | | | |
| | DIRECTORY ASSISTANCE DATA BASE SERVICE (DADS) | | | | | | | | | | | | | | |
| | Directory Assistance Data Base Service Charge Per Listing | | | | | 0.04 | | | | | | | | | |
| | Directory Assistance Data Base Service, per month | | | | DBSOF | 150.00 | | | | | | | | | |
| BRANDING - DIRECTORY ASSISTANCE | | | | | | | | | | | | | | | |
| | Facility Based CLEC | | | | | | | | | | | | | | |
| | Recording and Provisioning of DA Custom Branded Announcement | | | AMT | CBADA | 6,000.00 | 6,000.00 | | | | 7.86 | | | | |

| UNBUNDLED NETWORK ELEMENTS - Kentucky | | | | | | | | | | | Attachment: 2 | | Exhibit: D | | |
|---------------------------------------|--|---------|------|---|-------|-----------|--------------|----------|-------------------------|----------------------------------|--------------------------------------|--|--|---|---|
| CATEGORY | RATE ELEMENTS | Interim | Zone | BCS | USOC | RATES(\$) | | | | Svc Order Submitted Elec per LSR | Svc Order Submitted Manually per LSR | Incremental Charge - Manual Svc Order vs. Electronic-1st | Incremental Charge - Manual Svc Order vs. Electronic-Add'l | Incremental Charge - Manual Svc Order vs. Electronic-Disc 1st | Incremental Charge - Manual Svc Order vs. Electronic-Disc Add'l |
| | | | | | | Rec | Nonrecurring | | Nonrecurring Disconnect | | | | | | |
| | | | | | | | First | Add'l | First | Add'l | SOMEK | SOMAN | SOMAN | SOMAN | SOMAN |
| | Loading of Custom Branded Announcement per Switch | | | AMT | CBADC | | 1,170.00 | 1,170.00 | | | | 7.86 | | | |
| | UNEP CLEC | | | | | | | | | | | | | | |
| | Recording of DA Custom Branded Announcement | | | | | | 3,000.00 | 3,000.00 | | | | 7.86 | | | |
| | Loading of DA Custom Branded Announcement per Switch per OCN | | | | | | 1,170.00 | 1,170.00 | | | | 7.86 | | | |
| | Unbranding via OLNS for UNEP CLEC | | | | | | | | | | | | | | |
| | Loading of DA per OCN (1 OCN per Order) | | | | | | 420.00 | 420.00 | | | | 7.86 | | | |
| | Loading of DA per Switch per OCN | | | | | | 16.00 | 16.00 | | | | 7.86 | | | |
| | SELECTIVE ROUTING | | | | | | | | | | | | | | |
| | Selective Routing Per Unique Line Class Code Per Request Per Switch | | | | USRCR | | 93.53 | 93.53 | 15.58 | 15.58 | | 7.86 | | | |
| | VIRTUAL COLLOCATION | | | | | | | | | | | | | | |
| | Virtual Collocation - Application Cost | | | AMTFS | EAF | | 2,419.86 | 2,419.86 | 1.01 | 1.01 | | 7.86 | | | |
| | Virtual Collocation - Cable Installation Cost, per cable | | | AMTFS | ESPCX | | 1,729.11 | 1,729.11 | 45.16 | 45.16 | | 7.86 | | | |
| | Virtual Collocation - Floor Space, per sq. ft. | | | AMTFS | ESPVX | 7.99 | | | | | | | | | |
| | Virtual Collocation - Power, per fused amp | | | AMTFS | ESPAX | 8.06 | | | | | | | | | |
| | Virtual Collocation - Cable Support Structure, per entrance cable | | | AMTFS | ESPSX | 17.38 | | | | | | | | | |
| | Virtual Collocation - 2-wire Cross Connects (loop) | | | UEANL, UEA, UDN, UDC, UAL, UHL, UCL, UEQ, AMTFS, UDL, UNCVX, UNCDX, UNCNX | UEAC2 | 0.0309 | 24.68 | 23.68 | 12.14 | 10.95 | | 7.86 | | | |
| | Virtual Collocation - 4-wire Cross Connects (loop) | | | UEA, UHL, UCL, UDL, AMTFS, UAL, UDN, UNCVX, UNCDX | UEAC4 | 0.0619 | 24.88 | 23.82 | 12.77 | 11.46 | | 7.86 | | | |
| | Virtual Collocation - 2-Fiber Cross Connects | | | AMTFS, UDL12, UDLO3, U1T48, U1T12, U1T03, ULDO3, ULD12, ULD48, UDF | CNC2F | 3.80 | 41.94 | 30.51 | 14.76 | 11.84 | | 7.86 | | | |
| | Virtual Collocation - 4-Fiber Cross Connects | | | AMTFS, UDL12, UDLO3, U1T48, U1T12, U1T03, ULDO3, ULD12, ULD48, UDF | CNC4F | 7.59 | 51.29 | 39.87 | 19.41 | 16.49 | | 7.86 | | | |
| | Virtual collocation - Special Access & UNE, cross-connect per DS1 | | | USL, ULC, AMTFS, ULR, UXTD1, UNC1X, ULDD1, U1TD1, USLEL, UNLD1 | CNC1X | 1.48 | 44.23 | 31.98 | 12.81 | 11.57 | | | | | |
| | Virtual collocation - Special Access & UNE, cross-connect per DS3 | | | USL, ULC, AMTFS, U E3, U1TD3, UXTS1, UXTD3, UNC3X, UNCSX, ULDD3, U1TS1, ULDS1, UDLSX, UNLD3 | CND3X | 18.89 | 41.93 | 30.51 | 14.75 | 11.83 | | | | | |
| | Virtual Collocation - Co-Carrier Cross Connects - Fiber Cable Support Structure, per linear foot | | | AMTFS | VE1CB | 0.003 | | | | | | | | | |
| | Virtual Collocation - Co-Carrier Cross Connects - Copper/Coax Cable Support Structure, per linear ft | | | AMTFS | VE1CD | 0.0045 | | | | | | | | | |
| | Virtual Collocation - Co-Carrier Cross Connects - Fiber Cable Support Structure, per cable | | | AMTFS | VE1CC | | 535.55 | | | | | | | | |
| | Virtual Collocation - Co-Carrier Cross Connects - Copper/Coax Cable Support Structure, per cable | | | AMTFS | VE1CE | | 535.55 | | | | | | | | |
| | Virtual Collocation Cable Records - per request | | | AMTFS | VE1BA | | 1,524.45 | 980.01 | 267.02 | 267.02 | | | | | |
| | Virtual Collocation Cable Records - VG/DS0 Cable, per cable record | | | AMTFS | VE1BB | | 656.37 | 656.37 | 379.70 | 379.70 | | | | | |
| | Virtual Collocation Cable Records - VG/DS0 Cable, per each 100 pair | | | AMTFS | VE1BC | | 9.65 | 9.65 | 11.84 | 11.84 | | | | | |
| | Virtual Collocation Cable Records -DS1, per T1TIE | | | AMTFS | VE1BD | | 4.52 | 4.52 | 5.54 | 5.54 | | | | | |
| | Virtual Collocation Cable Records - DS3, per T3TIE | | | AMTFS | VE1BE | | 15.81 | 15.81 | 19.39 | 19.39 | | | | | |

| UNBUNDLED NETWORK ELEMENTS - Kentucky | | | | | | | | | | Attachment: 2 | | Exhibit: D | | | | |
|---|--|---------|------|--------------|-------|-----------|--------------|------------|-------------------------|----------------------------------|--------------------------------------|--|--|---|---|---------------|
| CATEGORY | RATE ELEMENTS | Interim | Zone | BCS | USOC | RATES(\$) | | | | Svc Order Submitted Elec per LSR | Svc Order Submitted Manually per LSR | Incremental Charge - Manual Svc Order vs. Electronic-1st | Incremental Charge - Manual Svc Order vs. Electronic-Add'l | Incremental Charge - Manual Svc Order vs. Electronic-Disc 1st | Incremental Charge - Manual Svc Order vs. Electronic-Disc Add'l | |
| | | | | | | Rec | Nonrecurring | | Nonrecurring Disconnect | | | | | | | OSS Rates(\$) |
| | | | | | | | First | Add'l | First | Add'l | SOMEc | SOMAN | SOMAN | SOMAN | SOMAN | SOMAN |
| | Virtual Collocation Cable Records - Fiber Cable, per 99 fiber records | | | AMTFS | VE1BF | | 169.63 | 169.63 | 154.85 | 154.85 | | | | | | |
| | Virtual collocation - Security Escort - Basic, per half hour | | | AMTFS | SPTBX | | 33.98 | 21.53 | | | | | | | | |
| | Virtual collocation - Security Escort - Overtime, per half hour | | | AMTFS | SPTOX | | 44.26 | 27.81 | | | | | | | | |
| | Virtual collocation - Security Escort - Premium, per half hour | | | AMTFS | SPTPX | | 54.54 | 34.09 | | | | | | | | |
| | Virtual collocation - Maintenance in CO - Basic, per half hour | | | AMTFS | CTRLX | | 56.07 | 21.53 | | | | | | | | |
| | Virtual collocation - Maintenance in CO - Overtime, per half hour | | | AMTFS | SPTOM | | 73.23 | 27.81 | | | | | | | | |
| | Virtual collocation - Maintenance in CO - Premium per half hour | | | AMTFS | SPTPM | | 90.39 | 34.09 | | | | | | | | |
| VIRTUAL COLLOCATION | | | | | | | | | | | | | | | | |
| | Virtual Collocation - 2-wire Cross Connect, Exchange Port 2-Wire Analog - Res | | | UEPSR | VE1R2 | 0.0309 | 24.68 | 23.68 | 12.14 | 10.95 | | 7.86 | | | | |
| | Virtual Collocation 2-Wire Cross Connect, Exchange Port 2-Wire Line Side PBX Trunk - Bus | | | UEPSP | VE1R2 | 0.0309 | 24.68 | 23.68 | 12.14 | 10.95 | | 7.86 | | | | |
| | Virtual Collocation 2-Wire Cross Connect, Exchange Port 2-Wire Voice Grade PBX Trunk - Res | | | UEPSE | VE1R2 | 0.0309 | 24.68 | 23.68 | 12.14 | 10.95 | | 7.86 | | | | |
| | Virtual Collocation 2-Wire Cross Connect, Exchange Port 2-Wire Analog Bus | | | UEPSB | VE1R2 | 0.0309 | 24.68 | 23.68 | 12.14 | 10.95 | | 7.86 | | | | |
| | Virtual Collocation 2-Wire Cross Connect, Exchange Port 2-Wire ISDN | | | UEPSX | VE1R2 | 0.0309 | 24.68 | 23.68 | 12.14 | 10.95 | | 7.86 | | | | |
| | Virtual Collocation 2-Wire Cross Connect, Exchange Port 2-Wire ISDN | | | UEPTX | VE1R2 | 0.0309 | 24.68 | 23.68 | 12.14 | 10.95 | | 7.86 | | | | |
| | Virtual Collocation 4-Wire Cross Connect, Exchange Port 4-Wire ISDN DS1 | | | UEPEX | VE1R4 | 1.48 | 44.23 | 31.98 | 12.81 | 11.57 | | 7.86 | | | | |
| VIRTUAL COLLOCATION | | | | | | | | | | | | | | | | |
| | Virtual Collocation-2 Wire Cross Connects (Loop) for Line Splitting | | | UEPSR, UEPSB | VE1LS | 0.309 | 24.68 | 23.68 | 12.14 | 10.95 | | 7.86 | | | | |
| PHYSICAL COLLOCATION | | | | | | | | | | | | | | | | |
| | Physical Collocation-2 Wire Cross Connects (Loop) for Line Splitting | | | UEPSR, UEPSB | PE1LS | 0.0333 | 24.68 | 23.68 | 12.14 | 10.95 | | 7.86 | | | | |
| AIN SELECTIVE CARRIER ROUTING | | | | | | | | | | | | | | | | |
| | Regional Service Establishment | | | SRC | SRCEC | | 193,401.00 | 193,401.00 | 9,483.34 | 9,483.34 | | 7.86 | | | | |
| | End Office Establishment | | | SRC | SRCEO | | 194.09 | 194.09 | 0.85 | 0.85 | | 7.86 | | | | |
| | Line/Port NRC, per end user | | | SRC | SRCLP | | 2.06 | 2.06 | | | | 7.86 | | | | |
| | Query NRC, per query | | | | | 0.0037502 | | | | | | | | | | |
| AIN - BELLSOUTH AIN SMS ACCESS SERVICE | | | | | | | | | | | | | | | | |
| | AIN SMS Access Service - Service Establishment, Per State, Initial Setup | | | A1N | CAMSE | | 43.55 | 43.55 | 44.93 | 44.93 | | 7.86 | | | | |
| | AIN SMS Access Service - Port Connection - Dial/Shared Access | | | A1N | CAMDP | | 8.64 | 8.64 | 10.03 | 10.03 | | 7.86 | | | | |
| | AIN SMS Access Service - Port Connection - ISDN Access | | | A1N | CAM1P | | 8.64 | 8.64 | 10.03 | 10.03 | | 7.86 | | | | |
| | AIN SMS Access Service - User Identification Codes - Per User ID Code | | | A1N | CAMAU | | 38.65 | 38.65 | 29.88 | 29.88 | | 7.86 | | | | |
| | AIN SMS Access Service - Security Card, Per User ID Code, Initial or Replacement | | | A1N | CAMRC | | 75.08 | 75.08 | 12.93 | 12.93 | | 7.86 | | | | |
| | AIN SMS Access Service - Storage, Per Unit (100 Kilobytes) | | | | | 0.0025 | | | | | | | | | | |
| | AIN SMS Access Service - Session, Per Minute | | | | | 0.666 | | | | | | | | | | |
| | AIN SMS Access Service - Company Performed Session, Per Minute | | | | | 0.4608 | | | | | | | | | | |
| AIN - BELLSOUTH AIN TOOLKIT SERVICE | | | | | | | | | | | | | | | | |
| | AIN Toolkit Service - Service Establishment Charge, Per State, Initial Setup | | | CAM | BAPSC | | 43.55 | 43.55 | 44.93 | 44.93 | | 7.86 | | | | |
| | AIN Toolkit Service - Training Session, Per Customer | | | | BAPVX | | 8,436.93 | 8,436.93 | | | | 7.86 | | | | |
| | AIN Toolkit Service - Trigger Access Charge, Per Trigger, Per DN, Term, Attempt | | | | BAPTT | | 8.64 | 8.64 | 10.03 | 10.03 | | 7.86 | | | | |
| | AIN Toolkit Service - Trigger Access Charge, Per Trigger, Per DN, Off-Hook Delay | | | | BAPTD | | 8.64 | 8.64 | 10.03 | 10.03 | | 7.86 | | | | |
| | AIN Toolkit Service - Trigger Access Charge, Per Trigger, Per DN, Off-Hook Immediate | | | | BAPTM | | 8.64 | 8.64 | 10.03 | 10.03 | | 7.86 | | | | |
| | AIN Toolkit Service - Trigger Access Charge, Per Trigger, Per DN, 10-Digit PODP | | | | BAPTO | | 51.01 | 51.01 | 18.50 | 18.50 | | 7.86 | | | | |
| | AIN Toolkit Service - Trigger Access Charge, Per Trigger, Per DN, CDP | | | | BAPTC | | 51.01 | 51.01 | 18.50 | 18.50 | | 7.86 | | | | |

| UNBUNDLED NETWORK ELEMENTS - Kentucky | | | | | | | | | | Attachment: 2 | | Exhibit: D | | | |
|--|--|---------|------|-------|-------|-----------|--------------|--------|-------------------------|----------------------------------|--------------------------------------|--|--|---|---|
| CATEGORY | RATE ELEMENTS | Interim | Zone | BCS | USOC | RATES(\$) | | | | Svc Order Submitted Elec per LSR | Svc Order Submitted Manually per LSR | Incremental Charge - Manual Svc Order vs. Electronic-1st | Incremental Charge - Manual Svc Order vs. Electronic-Add'l | Incremental Charge - Manual Svc Order vs. Electronic-Disc 1st | Incremental Charge - Manual Svc Order vs. Electronic-Disc Add'l |
| | | | | | | Rec | Nonrecurring | | Nonrecurring Disconnect | | | | | | |
| | | | | | | | First | Add'l | First | Add'l | SOMEc | SOMAN | SOMAN | SOMAN | SOMAN |
| | AIN Toolkit Service - Trigger Access Charge, Per Trigger, Per DN, Feature Code | | | | BAPTF | | 51.01 | 51.01 | 18.50 | 18.50 | | 7.86 | | | |
| | AIN Toolkit Service - Query Charge, Per Query | | | | | 0.0549207 | | | | | | | | | |
| | AIN Toolkit Service - Type 1 Node Charge, Per AIN Toolkit Subscription, Per Node, Per Query | | | | | 0.0066492 | | | | | | | | | |
| | AIN Toolkit Service - SCP Storage Charge, Per SMS Access Account, Per 100 Kilobytes | | | | | 0.07 | | | | | | | | | |
| | AIN Toolkit Service - Monthly report - Per AIN Toolkit Service Subscription | | | CAM | BAPMS | 7.87 | 8.64 | 8.64 | 6.08 | 6.08 | | 7.86 | | | |
| | AIN Toolkit Service - Special Study - Per AIN Toolkit Service Subscription | | | CAM | BAPLS | 3.26 | 9.56 | 9.56 | | | | 7.86 | | | |
| | AIN Toolkit Service - Call Event Report - Per AIN Toolkit Service Subscription | | | CAM | BAPDS | 4.72 | 8.64 | 8.64 | 6.08 | 6.08 | | 7.86 | | | |
| | AIN Toolkit Service - Call Event Special Study - Per AIN Toolkit Service Subscription | | | CAM | BAPES | 0.11 | 9.56 | 9.56 | | | | 7.86 | | | |
| ENHANCED EXTENDED LINK (EELs) | | | | | | | | | | | | | | | |
| NOTE: New Density Zone 1 EELs are available in the following MSAs: Orlando, FL; Miami, FL; Ft. Lauderdale, FL; Atlanta, Ga; New Orleans, LA, | | | | | | | | | | | | | | | |
| NOTE: Charlotte-Gastonia-Rockhill, NC; Greensboro-Winston Salem-High Point, NC; and Nashville, TN. | | | | | | | | | | | | | | | |
| NOTE: In all states, EEL network elements shown below also apply to currently combined facilities which are converted to UNE rates. A Switch As Is Charge applies to currently combined facilities converted to UNEs.(Non-recurring rates do not apply.) | | | | | | | | | | | | | | | |
| NOTE: In All States the EEL network elements apply to ordinarily combined network elements.(No Switch As Is Charge.) When ordering ordinarily combined network elements, Non-recurring rates do apply. | | | | | | | | | | | | | | | |
| 2-WIRE VOICE GRADE EXTENDED LOOP WITH DEDICATED DS1 INTEROFFICE TRANSPORT (EEL) | | | | | | | | | | | | | | | |
| | First 2-Wire VG Loop(SL2) in a DS1 Interofficed Transport Combination - Zone 1 | | 1 | UNCVX | UEAL2 | 12.67 | 125.22 | 60.48 | 59.69 | 7.84 | | 7.86 | | | |
| | First 2-Wire VG Grade Loop(SL2) in a DS1 Interofficed Transport Combination - Zone 2 | | 2 | UNCVX | UEAL2 | 17.45 | 125.22 | 60.48 | 59.69 | 7.84 | | 7.86 | | | |
| | First 2-Wire VG Grade Loop(SL2) in a DS1 Interofficed Transport Combination - Zone 3 | | 3 | UNCVX | UEAL2 | 33.22 | 125.22 | 60.48 | 59.69 | 7.84 | | 7.86 | | | |
| | Interoffice Transport - Dedicated - DS1 combination - Per Mile per month | | | UNC1X | 1L5XX | 0.19 | | | | | | | | | |
| | Interoffice Transport - Dedicated - DS1 combination - Facility Termination per month | | | UNC1X | U1TF1 | 79.02 | 181.24 | 123.53 | 56.72 | 22.32 | | 7.86 | | | |
| | DS1 Channelization System Per Month | | | UNC1X | MQ1 | 113.33 | 57.26 | 14.74 | 1.86 | 1.67 | | 7.86 | | | |
| | Voice Grade COCI - DS1 To Ds0 Interface - Per Month | | | UNCVX | 1D1VG | 0.62 | 6.71 | 4.84 | | | | 7.86 | | | |
| | Each Additional 2-Wire VG Loop(SL 2) in the same DS1 Interoffice Transport Combination - Zone 1 | | 1 | UNCVX | UEAL2 | 12.67 | 125.22 | 60.48 | 59.69 | 7.84 | | 7.86 | | | |
| | Each Additional 2-Wire VG Loop(SL2) in the same DS1 Interoffice Transport Combination - Zone 2 | | 2 | UNCVX | UEAL2 | 17.45 | 125.22 | 60.48 | 59.69 | 7.84 | | 7.86 | | | |
| | Each Additional 2-Wire VG Loop(SL2) in the same DS1 Interoffice Transport Combination - Zone 3 | | 3 | UNCVX | UEAL2 | 33.22 | 125.22 | 60.48 | 59.69 | 7.84 | | 7.86 | | | |
| | Voice Grade COCI - DS1 to DS0 Channel System combination - per month | | | UNCVX | 1D1VG | 0.62 | 6.71 | 4.84 | | | | 7.86 | | | |
| | Nonrecurring Currently Combined Network Elements Switch -As-Is Charge | | | UNC1X | UNCCC | | 8.98 | 8.98 | 11.17 | 11.17 | | 7.86 | | | |
| 4-WIRE VOICE GRADE EXTENDED LOOP WITH DEDICATED DS1 INTEROFFICE TRANSPORT (EEL) | | | | | | | | | | | | | | | |
| | First 4-Wire Analog Voice Grade Loop in a DS1 Interoffice Transport Combination - Zone 1 | | 1 | UNCVX | UEAL4 | 29.26 | 125.22 | 60.48 | 59.69 | 7.84 | | 7.86 | | | |
| | First 4-Wire Analog Voice Grade Loop in a DS1 Interoffice Transport Combination - Zone 2 | | 2 | UNCVX | UEAL4 | 34.25 | 125.22 | 60.48 | 59.69 | 7.84 | | 7.86 | | | |
| | First 4-Wire Analog Voice Grade Loop in a DS1 Interoffice Transport Combination - Zone 3 | | 3 | UNCVX | UEAL4 | 85.06 | 125.22 | 60.48 | 59.69 | 7.84 | | 7.86 | | | |
| | Interoffice Transport - Dedicated - DS1 combination - Per Mile Per Month | | | UNC1X | 1L5XX | 0.19 | | | | | | | | | |
| | Interoffice Transport - Dedicated - DS1 - Facility Termination Per Month | | | UNC1X | U1TF1 | 79.02 | 181.24 | 123.53 | 56.72 | 22.32 | | 7.86 | | | |
| | Channelization - Channel System DS1 to DS0 combination Per Month | | | UNC1X | MQ1 | 113.33 | 57.26 | 14.74 | 1.86 | 1.67 | | 7.86 | | | |
| | Voice Grade COCI - DS1 to DS0 Channel System combination - per month | | | UNCVX | 1D1VG | 0.62 | 6.71 | 4.84 | | | | 7.86 | | | |
| | Additional 4-Wire Analog Voice Grade Loop in same DS1 Interoffice Transport Combination - Zone 1 | | 1 | UNCVX | UEAL4 | 29.26 | 125.22 | 60.48 | 59.69 | 7.84 | | 7.86 | | | |
| | Additional 4-Wire Analog Voice Grade Loop in same DS1 Interoffice Transport Combination - Zone 2 | | 2 | UNCVX | UEAL4 | 34.25 | 125.22 | 60.48 | 59.69 | 7.84 | | 7.86 | | | |
| | Additional 4-Wire Analog Voice Grade Loop in same DS1 Interoffice Transport Combination - Zone 3 | | 3 | UNCVX | UEAL4 | 85.06 | 125.22 | 60.48 | 59.69 | 7.84 | | 7.86 | | | |

| UNBUNDLED NETWORK ELEMENTS - Kentucky | | | | | | | | | | | Attachment: 2 | | Exhibit: D | | | | | | | | | | | | |
|--|--|---------|------|-------|-------|-----------|----------------------------------|--------------------------------------|--|--|---|---|---------------|--------------|-------|-------------------------|--|-------|-------|-------|-------|-------|-------|--|--|
| CATEGORY | RATE ELEMENTS | Interim | Zone | BCS | USOC | RATES(\$) | Svc Order Submitted Elec per LSR | Svc Order Submitted Manually per LSR | Incremental Charge - Manual Svc Order vs. Electronic-1st | Incremental Charge - Manual Svc Order vs. Electronic-Add'l | Incremental Charge - Manual Svc Order vs. Electronic-Disc 1st | Incremental Charge - Manual Svc Order vs. Electronic-Disc Add'l | OSS Rates(\$) | | | | | | | | | | | | |
| | | | | | | | | | | | | | Rec | Nonrecurring | | Nonrecurring Disconnect | | SOMEc | SOMAN | SOMAN | SOMAN | SOMAN | SOMAN | | |
| | | | | | | | | | | | | | First | Add'l | First | Add'l | | | | | | | | | |
| | Voice Grade COCI - DS1 to DS0 Channel System combination - per month | | | UNCVX | 1D1VG | 0.62 | | 6.71 | 4.84 | | | | | | | | | | | | | | | | |
| | Nonrecurring Currently Combined Network Elements Switch -As-Is Charge | | | UNC1X | UNCCC | | | 8.98 | 8.98 | | | | 11.17 | 11.17 | | | | | | | | | | | |
| 4-WIRE 56 KBPS EXTENDED DIGITAL LOOP WITH DEDICATED DS1 INTEROFFICE TRANSPORT (EEL) | | | | | | | | | | | | | | | | | | | | | | | | | |
| | First 4-Wire 56Kbps Digital Grade Loop in a DS1 Interoffice Transport Combination - Zone 1 | | 1 | UNCDX | UDL56 | 27.59 | | 125.22 | 60.48 | 59.69 | 7.84 | | | | | | | | | | | | | | |
| | First 4-wire 56Kbps Digital Grade Loop in a DS1 Interoffice Transport Combination - Zone 2 | | 2 | UNCDX | UDL56 | 32.48 | | 125.22 | 60.48 | 59.69 | 7.84 | | | | | | | | | | | | | | |
| | First 4-Wire 56Kbps Digital Grade Loop in a DS1 Interoffice Transport Combination - Zone 3 | | 3 | UNCDX | UDL56 | 36.37 | | 125.22 | 60.48 | 59.69 | 7.84 | | | | | | | | | | | | | | |
| | Interoffice Transport - Dedicated - DS1 combination - Per Mile Per Month | | | UNC1X | 1L5XX | 0.19 | | | | | | | | | | | | | | | | | | | |
| | Interoffice Transport - Dedicated - DS1 - combination Facility Termination Per Month | | | UNC1X | U1TF1 | 79.02 | | 181.24 | 123.53 | 56.72 | 22.32 | | | | | | | | | | | | | | |
| | Channelization - Channel System DS1 to DS0 combination Per Month | | | UNC1X | MQ1 | 113.33 | | 57.26 | 14.74 | 1.86 | 1.67 | | | | | | | | | | | | | | |
| | OCU-DP COCI (data) - DS1 to DS0 Channel System - per month (2.4-64kbs) | | | UNCDX | 1D1DD | 1.32 | | 6.71 | 4.84 | | | | | | | | | | | | | | | | |
| | Additional 4-Wire 56Kbps Digital Grade Loop in same DS1 Interoffice Transport Combination - Zone 1 | | 1 | UNCDX | UDL56 | 27.59 | | 125.22 | 60.48 | 59.69 | 7.84 | | | | | | | | | | | | | | |
| | Additional 4-Wire 56Kbps Digital Grade Loop in same DS1 Interoffice Transport Combination - Zone 2 | | 2 | UNCDX | UDL56 | 32.48 | | 125.22 | 60.48 | 59.69 | 7.84 | | | | | | | | | | | | | | |
| | Additional 4-Wire 56Kbps Digital Grade Loop in same DS1 Interoffice Transport Combination - Zone 3 | | 3 | UNCDX | UDL56 | 36.37 | | 125.22 | 60.48 | 59.69 | 7.84 | | | | | | | | | | | | | | |
| | OCU-DP COCI (data) - DS1 to DS0 Channel System - combination per month (2.4-64kbs) | | | UNCDX | 1D1DD | 1.32 | | 6.71 | 4.84 | | | | | | | | | | | | | | | | |
| | Nonrecurring Currently Combined Network Elements Switch -As-Is Charge | | | UNC1X | UNCCC | | | 8.98 | 8.98 | | | | 11.17 | 11.17 | | | | | | | | | | | |
| 4-WIRE 64 KBPS EXTENDED DIGITAL LOOP WITH DEDICATED DS1 INTEROFFICE TRANSPORT (EEL) | | | | | | | | | | | | | | | | | | | | | | | | | |
| | First 4-Wire 64Kbps Digital Grade Loop in a DS1 Interoffice Transport Combination - Zone 1 | | 1 | UNCDX | UDL64 | 27.59 | | 125.22 | 60.48 | 59.69 | 7.84 | | | | | | | | | | | | | | |
| | First 4-Wire 64Kbps Digital Grade Loop in a DS1 Interoffice Transport Combination - Zone 2 | | 2 | UNCDX | UDL64 | 32.48 | | 125.22 | 60.48 | 59.69 | 7.84 | | | | | | | | | | | | | | |
| | First 4-Wire 64Kbps Digital Grade Loop in a DS1 Interoffice Transport Combination - Zone 3 | | 3 | UNCDX | UDL64 | 36.37 | | 125.22 | 60.48 | 59.69 | 7.84 | | | | | | | | | | | | | | |
| | Interoffice Transport - Dedicated - DS1 combination - Per Mile Per Month | | | UNC1X | 1L5XX | 0.19 | | | | | | | | | | | | | | | | | | | |
| | Interoffice Transport - Dedicated - DS1 combination - Facility Termination Per Month | | | UNC1X | U1TF1 | 79.02 | | 181.24 | 123.53 | 56.72 | 22.32 | | | | | | | | | | | | | | |
| | Channelization - Channel System DS1 to DS0 combination Per Month | | | UNC1X | MQ1 | 113.33 | | 57.26 | 14.74 | 1.86 | 1.67 | | | | | | | | | | | | | | |
| | OCU-DP COCI (data) - DS1 to DS0 Channel System combination - per month (2.4-64kbs) | | | UNCDX | 1D1DD | 1.32 | | 6.71 | 4.84 | | | | | | | | | | | | | | | | |
| | Additional 4-Wire 64Kbps Digital Grade Loop in same DS1 Interoffice Transport Combination - Zone 1 | | 1 | UNCDX | UDL64 | 27.59 | | 125.22 | 60.48 | 59.69 | 7.84 | | | | | | | | | | | | | | |
| | Additional 4-Wire 64Kbps Digital Grade Loop in same DS1 Interoffice Transport Combination - Zone 2 | | 2 | UNCDX | UDL64 | 32.48 | | 125.22 | 60.48 | 59.69 | 7.84 | | | | | | | | | | | | | | |
| | Additional 4-Wire 64Kbps Digital Grade Loop in same DS1 Interoffice Transport Combination - Zone 3 | | 3 | UNCDX | UDL64 | 36.37 | | 125.22 | 60.48 | 59.69 | 7.84 | | | | | | | | | | | | | | |
| | OCU-DP COCI (data) - DS1 to DS0 Channel System combination - per month (2.4-64kbs) | | | UNCDX | 1D1DD | 1.32 | | 6.71 | 4.84 | | | | | | | | | | | | | | | | |
| | Nonrecurring Currently Combined Network Elements Switch -As-Is Charge | | | UNC1X | UNCCC | | | 8.98 | 8.98 | | | | 11.17 | 11.17 | | | | | | | | | | | |
| 4-WIRE DS1 DIGITAL EXTENDED LOOP WITH DEDICATED DS1 INTEROFFICE TRANSPORT (EEL) | | | | | | | | | | | | | | | | | | | | | | | | | |
| | 4-Wire DS1 Digital Loop in Combination with DS1 Interoffice Transport - Zone 1 | | 1 | UNC1X | USLXX | 86.47 | | 210.70 | 114.60 | 63.96 | 17.97 | | | | | | | | | | | | | | |
| | 4-Wire DS1 Digital Loop in Combination with DS1 Interoffice Transport - Zone 2 | | 2 | UNC1X | USLXX | 114.10 | | 210.70 | 114.60 | 63.96 | 17.97 | | | | | | | | | | | | | | |
| | 4-Wire DS1 Digital Loop in Combination with DS1 Interoffice Transport - Zone 3 | | 3 | UNC1X | USLXX | 297.76 | | 210.70 | 114.60 | 63.96 | 17.97 | | | | | | | | | | | | | | |
| | Interoffice Transport - Dedicated - DS1 combination - Per Mile Per Month | | | UNC1X | 1L5XX | 0.19 | | | | | | | | | | | | | | | | | | | |

| UNBUNDLED NETWORK ELEMENTS - Kentucky | | | | | | | | | | Attachment: 2 | | Exhibit: D | | | |
|---|--|---------|------|-------|-------|-----------|--------------|--------|-------------------------|----------------------------------|--------------------------------------|--|--|---|---|
| CATEGORY | RATE ELEMENTS | Interim | Zone | BCS | USOC | RATES(\$) | | | | Svc Order Submitted Elec per LSR | Svc Order Submitted Manually per LSR | Incremental Charge - Manual Svc Order vs. Electronic-1st | Incremental Charge - Manual Svc Order vs. Electronic-Add'l | Incremental Charge - Manual Svc Order vs. Electronic-Disc 1st | Incremental Charge - Manual Svc Order vs. Electronic-Disc Add'l |
| | | | | | | Rec | Nonrecurring | | Nonrecurring Disconnect | | | | | | |
| | | | | | | First | Add'l | First | Add'l | SOMEK | SOMAN | SOMAN | SOMAN | SOMAN | SOMAN |
| | Interoffice Transport - Dedicated - DS1 combination - Facility Termination Per Month | | | UNC1X | U1TF1 | 79.02 | 181.24 | 123.53 | 56.72 | 22.32 | | 7.86 | | | |
| | Nonrecurring Currently Combined Network Elements Switch -As-Is Charge | | | UNC1X | UNCCC | | 8.98 | 8.98 | 11.17 | 11.17 | | 7.86 | | | |
| 4-WIRE DS1 DIGITAL EXTENDED LOOP WITH DEDICATED DS3 INTEROFFICE TRANSPORT (EEL) | | | | | | | | | | | | | | | |
| | First DS1Loop in DS3 Interoffice Transport Combination - Zone 1 | | 1 | UNC1X | USLXX | 86.47 | 210.70 | 114.60 | 63.96 | 17.97 | | 7.86 | | | |
| | First DS1Loop in DS3 Interoffice Transport Combination - Zone 2 | | 2 | UNC1X | USLXX | 114.10 | 210.70 | 114.60 | 63.96 | 17.97 | | 7.86 | | | |
| | First DS1Loop in DS3 Interoffice Transport Combination - Zone 3 | | 3 | UNC1X | USLXX | 297.76 | 210.70 | 114.60 | 63.96 | 17.97 | | 7.86 | | | |
| | Interoffice Transport - Dedicated - DS3 combination - Per Mile Per Month | | | UNC3X | 1L5XX | 4.09 | | | | | | | | | |
| | Interoffice Transport - Dedicated - DS3 - Facility Termination per month | | | UNC3X | U1TF3 | 966.89 | 350.56 | 141.58 | 48.00 | 23.39 | | 7.86 | | | |
| | DS3 to DS1 Channel System combination per month | | | UNC3X | MQ3 | 158.20 | 115.48 | 56.53 | 15.12 | 5.30 | | 7.86 | | | |
| | DS3 Interface Unit (DS1 COCI) combination per month | | | UNC1X | UC1D1 | 11.80 | 6.71 | 4.84 | | | | 7.86 | | | |
| | Additional DS1Loop in DS3 Interoffice Transport Combination - Zone 1 | | 1 | UNC1X | USLXX | 86.47 | 210.70 | 114.60 | 63.96 | 17.97 | | 7.86 | | | |
| | Additional DS1Loop in DS3 Interoffice Transport Combination - Zone 2 | | 2 | UNC1X | USLXX | 114.10 | 210.70 | 114.60 | 63.96 | 17.97 | | 7.86 | | | |
| | Additional DS1Loop in DS3 Interoffice Transport Combination - Zone 3 | | 3 | UNC1X | USLXX | 297.76 | 210.70 | 114.60 | 63.96 | 17.97 | | 7.86 | | | |
| | DS3 Interface Unit (DS1 COCI) combination per month | | | UNC1X | UC1D1 | 11.80 | 6.71 | 4.84 | | | | 7.86 | | | |
| | Nonrecurring Currently Combined Network Elements Switch -As-Is Charge | | | UNC3X | UNCCC | | 8.98 | 8.98 | 11.17 | 11.17 | | 7.86 | | | |
| 2-WIRE VOICE GRADE EXTENDED LOOP/ 2 WIRE VOICE GRADE INTEROFFICE TRANSPORT (EEL) | | | | | | | | | | | | | | | |
| | 2-WireVG Loop used with 2-wire VG Interoffice Transport Combination - Zone 1 | | 1 | UNCVX | UEAL2 | 12.67 | 125.22 | 60.48 | 59.69 | 7.84 | | 7.86 | | | |
| | 2-WireVG Loop used with 2-wire VG Interoffice Transport Combination - Zone 2 | | 2 | UNCVX | UEAL2 | 17.45 | 125.22 | 60.48 | 59.69 | 7.84 | | 7.86 | | | |
| | 2-WireVG Loop used with 2-wire VG Interoffice Transport Combination - Zone 3 | | 3 | UNCVX | UEAL2 | 33.22 | 125.22 | 60.48 | 59.69 | 7.84 | | 7.86 | | | |
| | Interoffice Transport - Dedicated - 2-wire VG combination - Per Mile Per Month | | | UNCVX | 1L5XX | 0.01 | | | | | | | | | |
| | Interoffice Transport - Dedicated - 2- Wire Voice Grade combination - Facility Termination per month | | | UNCVX | U1TV2 | 23.95 | 98.09 | 53.67 | 56.31 | 22.42 | | 7.86 | | | |
| | Nonrecurring Currently Combined Network Elements Switch -As-Is Charge | | | UNCVX | UNCCC | | 8.98 | 8.98 | 11.17 | 11.17 | | 7.86 | | | |
| 4-WIRE VOICE GRADE EXTENDED LOOP/ 4 WIRE VOICE GRADE INTEROFFICE TRANSPORT (EEL) | | | | | | | | | | | | | | | |
| | 4-WireVG Loop used with 4-wire VG Interoffice Transport Combination - Zone 1 | | 1 | UNCVX | UEAL4 | 29.26 | 125.22 | 60.48 | 59.69 | 7.84 | | 7.86 | | | |
| | 4-WireVG Loop used with 4-wire VG Interoffice Transport Combination - Zone 2 | | 2 | UNCVX | UEAL4 | 34.25 | 125.22 | 60.48 | 59.69 | 7.84 | | 7.86 | | | |
| | 4-WireVG Loop used with 4-wire VG Interoffice Transport Combination - Zone 3 | | 3 | UNCVX | UEAL4 | 85.06 | 125.22 | 60.48 | 59.69 | 7.84 | | 7.86 | | | |
| | Interoffice Transport - Dedicated - 4-wire VG combination - Per Mile Per Month | | | UNCVX | 1L5XX | 0.01 | | | | | | | | | |
| | Interoffice Transport - Dedicated - 4- Wire Voice Grade combination - Facility Termination per month | | | UNCVX | U1TV4 | 21.28 | 98.09 | 53.67 | 56.31 | 22.42 | | 7.86 | | | |
| | Nonrecurring Currently Combined Network Elements Switch -As-Is Charge | | | UNCVX | UNCCC | | 8.98 | 8.98 | 11.17 | 11.17 | | 7.86 | | | |
| DS3 DIGITAL EXTENDED LOOP WITH DEDICATED DS3 INTEROFFICE TRANSPORT (EEL) | | | | | | | | | | | | | | | |
| | High Capacity Unbundled Local Loop - DS3 combination - Per Mile per month | | | UNC3X | 1L5ND | 9.25 | | | | | | | | | |
| | High Capacity Unbundled Local Loop - DS3 combination - Facility Termination per month | | | UNC3X | UE3PX | 308.31 | 237.36 | 147.69 | 83.43 | 32.67 | | 7.86 | | | |
| | Interoffice Transport - Dedicated - DS3 - Per Mile per month | | | UNC3X | 1L5XX | 4.09 | | | | | | | | | |
| | Interoffice Transport - Dedicated - DS3 combination - Facility Termination per per month | | | UNC3X | U1TF3 | 966.89 | 350.56 | 141.58 | 48.00 | 23.39 | | 7.86 | | | |
| | Nonrecurring Currently Combined Network Elements Switch -As-Is Charge | | | UNC3X | UNCCC | | 8.98 | 8.98 | 11.17 | 11.17 | | 7.86 | | | |
| STS1 DIGITAL EXTENDED LOOP WITH DEDICATED STS1 INTEROFFICE TRANSPORT (EEL) | | | | | | | | | | | | | | | |

| UNBUNDLED NETWORK ELEMENTS - Kentucky | | | | | | | | | | | Attachment: 2 | | Exhibit: D | | |
|--|--|---------|------|-------|-------|-----------|--------------|--------|-------------------------|----------------------------------|--------------------------------------|--|--|---|---|
| CATEGORY | RATE ELEMENTS | Interim | Zone | BCS | USOC | RATES(\$) | | | | Svc Order Submitted Elec per LSR | Svc Order Submitted Manually per LSR | Incremental Charge - Manual Svc Order vs. Electronic-1st | Incremental Charge - Manual Svc Order vs. Electronic-Add'l | Incremental Charge - Manual Svc Order vs. Electronic-Disc 1st | Incremental Charge - Manual Svc Order vs. Electronic-Disc Add'l |
| | | | | | | Rec | Nonrecurring | | Nonrecurring Disconnect | | | | | | |
| | | | | | | First | Add'l | First | Add'l | SOMEc | SOMAN | SOMAN | SOMAN | SOMAN | SOMAN |
| | High Capacity Unbundled Local Loop - STS1 combination - Per Mile per month | | | UNCSX | 1L5ND | 9.25 | | | | | | | | | |
| | High Capacity Unbundled Local Loop - STS1 combination - Facility Termination per month | | | UNCSX | UDLS1 | 320.51 | 237.36 | 147.69 | 83.43 | 32.67 | | 7.86 | | | |
| | Interoffice Transport - Dedicated - STS1 combination - Per Mile per month | | | UNCSX | 1L5XX | 4.09 | | | | | | | | | |
| | Interoffice Transport - Dedicated - STS1 combination - Facility Termination per month | | | UNCSX | U1TFS | 945.79 | 350.56 | 141.58 | 48.00 | 23.39 | | 7.86 | | | |
| | Nonrecurring Currently Combined Network Elements Switch -As-Is Charge | | | UNCSX | UNCCC | | 8.98 | 8.98 | 11.17 | 11.17 | | 7.86 | | | |
| 2-WIRE ISDN EXTENDED LOOP WITH DS1 INTEROFFICE TRANSPORT (EEL) | | | | | | | | | | | | | | | |
| | First 2-Wire ISDN Loop in a DS1 Interoffice Combination Transport - Zone 1 | | 1 | UNCNX | U1L2X | 18.44 | 125.22 | 60.48 | 59.69 | 7.84 | | 7.86 | | | |
| | First 2-Wire ISDN Loop in a DS1 Interoffice Combination Transport - Zone 2 | | 2 | UNCNX | U1L2X | 25.08 | 125.22 | 60.48 | 59.69 | 7.84 | | 7.86 | | | |
| | First 2-Wire ISDN Loop in a DS1 Interoffice Combination Transport - Zone 3 | | 3 | UNCNX | U1L2X | 42.87 | 125.22 | 60.48 | 59.69 | 7.84 | | 7.86 | | | |
| | Interoffice Transport - Dedicated - DS1 combination - Per Mile | | | UNC1X | 1L5XX | 0.19 | | | | | | | | | |
| | Interoffice Transport - Dedicated - DS1 combination - Facility Termination per month | | | UNC1X | U1TF1 | 79.02 | 181.24 | 123.53 | 56.72 | 22.32 | | 7.86 | | | |
| | Channelization - Channel System DS1 to DS0 combination - per month | | | UNC1X | MQ1 | 113.33 | 57.26 | 14.74 | 1.86 | 1.67 | | 7.86 | | | |
| | 2-wire ISDN COCI (BRITE) - DS1 to DS0 Channel System combination - per month | | | UNCNX | UC1CA | 2.84 | 6.71 | 4.84 | | | | 7.86 | | | |
| | Additional 2-wire ISDN Loop in same DS1Interoffice Transport Combination - Zone 1 | | 1 | UNCNX | U1L2X | 18.44 | 125.22 | 60.48 | 59.69 | 7.84 | | 7.86 | | | |
| | Additional 2-wire ISDN Loop in same DS1Interoffice Transport Combination - Zone 2 | | 2 | UNCNX | U1L2X | 25.08 | 125.22 | 60.48 | 59.69 | 7.84 | | 7.86 | | | |
| | Additional 2-wire ISDN Loop in same DS1Interoffice Transport Combination - Zone 3 | | 3 | UNCNX | U1L2X | 42.87 | 125.22 | 60.48 | 59.69 | 7.84 | | 7.86 | | | |
| | 2-wire ISDN COCI (BRITE) - DS1 to DS0 Channel System combination - per month | | | UNCNX | UC1CA | 2.84 | 6.71 | 4.84 | | | | 7.86 | | | |
| | Nonrecurring Currently Combined Network Elements Switch -As-Is Charge | | | UNC1X | UNCCC | | 8.98 | 8.98 | 11.17 | 11.17 | | 7.86 | | | |
| 4-WIRE DS1 DIGITAL EXTENDED LOOP WITH DEDICATED STS-1 INTEROFFICE TRANSPORT (EEL) | | | | | | | | | | | | | | | |
| | First DS1 Loop in STS1 Interoffice Transport Combination - Zone 1 | | 1 | UNC1X | USLXX | 86.47 | 210.70 | 114.60 | 63.96 | 17.97 | | 7.86 | | | |
| | First DS1 Loop in STS1 Interoffice Transport Combination - Zone 2 | | 2 | UNC1X | USLXX | 114.10 | 210.70 | 114.60 | 63.96 | 17.97 | | 7.86 | | | |
| | First DS1 Loop in STS1 Interoffice Transport Combination - Zone 3 | | 3 | UNC1X | USLXX | 297.76 | 210.70 | 114.60 | 63.96 | 17.97 | | 7.86 | | | |
| | Interoffice Transport - Dedicated - STS1 combination - Per Mile Per Month | | | UNCSX | 1L5XX | 4.09 | | | | | | | | | |
| | Interoffice Transport - Dedicated - STS1 combination - Facility Termination | | | UNCSX | U1TFS | 945.79 | 350.56 | 141.58 | 48.00 | 23.39 | | 7.86 | | | |
| | STS1 to DS1 Channel System combination per month | | | UNCSX | MQ3 | 158.20 | 115.48 | 56.53 | 15.12 | 5.30 | | 7.86 | | | |
| | DS3 Interface Unit (DS1 COCI) combination per month | | | UNC1X | UC1D1 | 11.80 | 6.71 | 4.84 | | | | 7.86 | | | |
| | Additional DS1Loop in STS1 Interoffice Transport Combination - Zone 1 | | 1 | UNC1X | USLXX | 86.47 | 210.70 | 114.60 | 63.96 | 17.97 | | 7.86 | | | |
| | Additional DS1Loop in STS1 Interoffice Transport Combination - Zone 2 | | 2 | UNC1X | USLXX | 114.10 | 210.70 | 114.60 | 63.96 | 17.97 | | 7.86 | | | |
| | Additional DS1Loop in STS1 Interoffice Transport Combination - Zone 3 | | 3 | UNC1X | USLXX | 297.76 | 210.70 | 114.60 | 63.96 | 17.97 | | 7.86 | | | |
| | DS3 Interface Unit (DS1 COCI) combination per month | | | UNC1X | UC1D1 | 11.80 | 6.71 | 4.84 | | | | 7.86 | | | |
| | Nonrecurring Currently Combined Network Elements Switch -As-Is Charge | | | UNCSX | UNCCC | | 8.98 | 8.98 | 11.17 | 11.17 | | 7.86 | | | |
| 4-WIRE 56 KBPS DIGITAL EXTENDED LOOP WITH 56 KBPS INTEROFFICE TRANSPORT (EEL) | | | | | | | | | | | | | | | |
| | 4-wire 56 kbps Loop/4-wire 56 kbps Interoffice Transport Combination - Zone 1 | | 1 | UNCDX | UDL56 | 27.59 | 125.22 | 60.48 | 59.69 | 7.84 | | 7.86 | | | |
| | 4-wire 56 kbps Loop/4-wire 56 kbps Interoffice Transport Combination - Zone 2 | | 2 | UNCDX | UDL56 | 32.48 | 125.22 | 60.48 | 59.69 | 7.84 | | 7.86 | | | |
| | 4-wire 56 kbps Loop/4-wire 56 kbps Interoffice Transport Combination - Zone 3 | | 3 | UNCDX | UDL56 | 36.37 | 125.22 | 60.48 | 59.69 | 7.84 | | 7.86 | | | |

| UNBUNDLED NETWORK ELEMENTS - Kentucky | | | | | | | | | | Attachment: 2 | | Exhibit: D | | | |
|---|--|---------|------|-------|-------|-----------|--------------|--------|-------------------------|----------------------------------|--------------------------------------|--|--|---|---|
| CATEGORY | RATE ELEMENTS | Interim | Zone | BCS | USOC | RATES(\$) | | | | Svc Order Submitted Elec per LSR | Svc Order Submitted Manually per LSR | Incremental Charge - Manual Svc Order vs. Electronic-1st | Incremental Charge - Manual Svc Order vs. Electronic-Add'l | Incremental Charge - Manual Svc Order vs. Electronic-Disc 1st | Incremental Charge - Manual Svc Order vs. Electronic-Disc Add'l |
| | | | | | | Rec | Nonrecurring | | Nonrecurring Disconnect | | | | | | |
| | | | | | | First | Add'l | First | Add'l | SOMEc | SOMAN | SOMAN | SOMAN | SOMAN | SOMAN |
| | Interoffice Transport - Dedicated - 4-wire 56 kbps combination - Per Mile | | | UNCDX | 1L5XX | 0.01 | | | | | | | | | |
| | Interoffice Transport - Dedicated - 4-wire 56 kbps combination - Facility Termination | | | UNCDX | U1TD5 | 17.25 | 98.09 | 53.67 | 56.31 | 22.42 | | 7.86 | | | |
| | Nonrecurring Currently Combined Network Elements Switch -As-Is Charge | | | UNCDX | UNCCC | | 8.98 | 8.98 | 11.17 | 11.17 | | 7.86 | | | |
| 4-WIRE 64 KBPS DIGITAL EXTENDED LOOP WITH 64 KBPS INTEROFFICE TRANSPORT (EEL) | | | | | | | | | | | | | | | |
| | 4-wire 64 kbps Loop/4-wire 64 kbps Interoffice Transport Combination - Zone 1 | | 1 | UNCDX | UDL64 | 27.59 | 125.22 | 60.48 | 59.69 | 7.84 | | 7.86 | | | |
| | 4-wire 64 kbps Loop/4-wire 64 kbps Interoffice Transport Combination - Zone 2 | | 2 | UNCDX | UDL64 | 32.48 | 125.22 | 60.48 | 59.69 | 7.84 | | 7.86 | | | |
| | 4-wire 64 kbps Loop/4-wire 64 kbps Interoffice Transport Combination - Zone 3 | | 3 | UNCDX | UDL64 | 36.37 | 125.22 | 60.48 | 59.69 | 7.84 | | 7.86 | | | |
| | Interoffice Transport - Dedicated - 4-wire 64 kbps combination - Per Mile | | | UNCDX | 1L5XX | 0.01 | | | | | | | | | |
| | Interoffice Transport - Dedicated - 4-wire 64 kbps combination - Facility Termination | | | UNCDX | U1TD6 | 17.25 | 98.09 | 53.67 | 56.31 | 22.42 | | 7.86 | | | |
| | Nonrecurring Currently Combined Network Elements Switch -As-Is Charge | | | UNCDX | UNCCC | | 8.98 | 8.98 | 11.17 | 11.17 | | 7.86 | | | |
| ADDITIONAL NETWORK ELEMENTS | | | | | | | | | | | | | | | |
| When used as a part of a currently combined facility, the non-recurring charges do not apply, but a Switch As Is charge does apply. | | | | | | | | | | | | | | | |
| When used as ordinarily combined network elements in All States, the non-recurring charges apply and the Switch As Is Charge does not. | | | | | | | | | | | | | | | |
| Nonrecurring Currently Combined Network Elements "Switch As Is" Charge (One applies to each combination) | | | | | | | | | | | | | | | |
| | Nonrecurring Currently Combined Network Elements Switch -As-Is Charge - 2 wire/4-Wire VG | | | UNCVX | UNCCC | | 8.98 | 8.98 | 11.17 | 11.17 | | 7.86 | | | |
| | Nonrecurring Currently Combined Network Elements Switch -As-Is Charge - 56/64 kbps | | | UNCDX | UNCCC | | 8.98 | 8.98 | 11.17 | 11.17 | | 7.86 | | | |
| | Nonrecurring Currently Combined Network Elements Switch -As-Is Charge - DS1 | | | UNC1X | UNCCC | | 8.98 | 8.98 | 11.17 | 11.17 | | 7.86 | | | |
| | Nonrecurring Currently Combined Network Elements Switch -As-Is Charge - DS3 | | | UNC3X | UNCCC | | 8.98 | 8.98 | 11.17 | 11.17 | | 7.86 | | | |
| | Nonrecurring Currently Combined Network Elements Switch -As-Is Charge - STS1 | | | UNCSX | UNCCC | | 8.98 | 8.98 | 11.17 | 11.17 | | 7.86 | | | |
| NOTE: Local Channel - Dedicated Transport - minimum billing period - Below DS3=one month, DS3 and above=four months | | | | | | | | | | | | | | | |
| | Local Channel - Dedicated - 2-Wire Voice Grade | | | UNCXV | ULDV2 | 18.57 | 265.78 | 46.96 | 46.79 | 4.98 | | 7.86 | | | |
| | Local Channel - Dedicated - 4-Wire Voice Grade | | | UNCXV | ULDV4 | 19.86 | 266.48 | 47.65 | 47.54 | 5.73 | | 7.86 | | | |
| | Local Channel - Dedicated - DS1 per month Zone 1 | | 1 | UNC1X | ULDF1 | 40.46 | 209.60 | 176.51 | 30.21 | 21.07 | | 7.86 | | | |
| | Local Channel - Dedicated - DS1 Per Month Zone 2 | | 2 | UNC1X | ULDF1 | 43.39 | 209.60 | 176.51 | 30.21 | 21.07 | | 7.86 | | | |
| | Local Channel - Dedicated - DS1 - Per Month Zone 3 | | 3 | UNC1X | ULDF1 | 164.50 | 209.60 | 176.51 | 30.21 | 21.07 | | 7.86 | | | |
| | Local Channel - Dedicated - DS3 - Per Mile per month | | | UNC3X | 1LSNC | 8.74 | | | | | | | | | |
| | Local Channel - Dedicated - DS3 - Facility Termination | | | UNC3X | ULDF3 | 576.05 | 551.38 | 338.08 | 173.00 | 120.42 | | 7.86 | | | |
| | Local Channel - Dedicated - STS-1 - Per Mile per month | | | UNCSX | 1LSNC | 8.74 | | | | | | | | | |
| | Local Channel - Dedicated - STS-1 - Facility Termination | | | UNCSX | ULDFS | 543.24 | 551.38 | 338.08 | 173.00 | 120.42 | | 7.86 | | | |
| MULTIPLEXERS | | | | | | | | | | | | | | | |
| | Channelization - DS1 to DS0 Channel System | | | UXTD1 | MQ1 | 113.33 | 101.40 | 71.60 | 13.79 | 13.04 | | 7.86 | | | |
| | OCU-DP COCI (data) - DS1 to DS0 Channel System - per month (2.4-64kbs) | | | UDL | 1D1DD | 1.32 | 10.07 | 7.08 | | | | 7.86 | | | |
| | 2-wire ISDN COCI (BRITE) - DS1 to DS0 Channel System - per month | | | UDN | UC1CA | 2.84 | 10.07 | 7.08 | | | | 7.86 | | | |
| | Voice Grade COCI - DS1 to DS0 Channel System - per month | | | UEA | 1D1VG | 0.6228 | 10.07 | 7.08 | | | | 7.86 | | | |
| | DS3 to DS1 Channel System per month | | | UXTD3 | MQ3 | 158.20 | 199.23 | 118.62 | 50.16 | 48.59 | | 7.86 | | | |
| | STS1 to DS1 Channel System per month | | | UXTS1 | MQ3 | 158.20 | 199.23 | 118.62 | 50.16 | 48.59 | | 7.86 | | | |
| | DS3 Interface Unit (DS1 COCI) used with Loop per month | | | USL | UC1D1 | 11.80 | 10.07 | 7.08 | | | | 7.86 | | | |
| | DS3 Interface Unit (DS1 COCI) used with Local Channel per month | | | ULDD1 | UC1D1 | 11.80 | 10.07 | 7.08 | | | | 7.86 | | | |
| | DS3 Interface Unit (DS1 COCI) used with Interoffice Channel per month | | | U1TD1 | UC1D1 | 11.80 | 10.07 | 7.08 | | | | 7.86 | | | |
| Sub-Loop Feeder | | | | | | | | | | | | | | | |
| | Unbundled Sub-Loop Feeder Loop, 4-Wire DS1 - Statewide | | sw | UNC1X | USBFG | | | | | | | | | | |
| | Unbundled Sub-Loop Feeder Loop, 4-Wire DS1 - Zone 1 | | 1 | UNC1X | USBFG | 62.57 | 125.43 | 73.68 | | | | 81.82 | 21.56 | | |
| | Unbundled Sub-Loop Feeder Loop, 4-Wire DS1 - Zone 2 | | 2 | UNC1X | USBFG | 87.71 | 125.43 | 73.68 | | | | 81.82 | 21.56 | | |
| | Unbundled Sub-Loop Feeder Loop, 4-Wire DS1 - Zone 3 | | 3 | UNC1X | USBFG | 273.33 | 125.43 | 73.68 | | | | 81.82 | 21.56 | | |
| | Unbundled Sub-Loop Feeder Loop, 4-Wire DS1 - Zone 4 | | 4 | UNC1X | USBFG | | | | | | | | | | |
| UNBUNDLED LOCAL EXCHANGE SWITCHING(PORTS) | | | | | | | | | | | | | | | |

| UNBUNDLED NETWORK ELEMENTS - Kentucky | | | | | | | | | | Attachment: 2 | | Exhibit: D | | | |
|---|---|---------|------|-------|-------|-----------|--------------|-------|-------------------------|----------------------------------|--------------------------------------|--|--|---|---|
| CATEGORY | RATE ELEMENTS | Interim | Zone | BCS | USOC | RATES(\$) | | | | Svc Order Submitted Elec per LSR | Svc Order Submitted Manually per LSR | Incremental Charge - Manual Svc Order vs. Electronic-1st | Incremental Charge - Manual Svc Order vs. Electronic-Add'l | Incremental Charge - Manual Svc Order vs. Electronic-Disc 1st | Incremental Charge - Manual Svc Order vs. Electronic-Disc Add'l |
| | | | | | | Rec | Nonrecurring | | Nonrecurring Disconnect | | | | | | |
| | | | | | | | First | Add'l | First | Add'l | SOMEc | SOMAN | SOMAN | SOMAN | SOMAN |
| Exchange Ports | | | | | | | | | | | | | | | |
| NOTE: Although the Port Rate includes all available features in GA, KY, LA & TN, the desired features will need to be ordered using retail USOCs | | | | | | | | | | | | | | | |
| 2-WIRE VOICE GRADE LINE PORT RATES (RES) | | | | | | | | | | | | | | | |
| | Exchange Ports - 2-Wire Analog Line Port- Res. | | | UEPSR | UEPRL | 1.49 | 3.74 | 3.63 | 2.23 | 2.13 | | 7.86 | | | |
| | Exchange Ports - 2-Wire Analog Line Port with Caller ID - Res. | | | UEPSR | UEPRC | 1.49 | 3.74 | 3.63 | 2.23 | 2.13 | | 7.86 | | | |
| | Exchange Ports - 2-Wire Analog Line Port outgoing only - Res. | | | UEPSR | UEPRO | 1.49 | 3.74 | 3.63 | 2.23 | 2.13 | | 7.86 | | | |
| | Exchange Ports - 2-Wire VG unbundled KY extended local dialing party Port with Caller ID - Res. | | | UEPSR | UEPRM | 1.49 | 3.74 | 3.63 | 2.23 | 2.13 | | 7.86 | | | |
| | Exchange Ports - 2-Wire VG unbundled res, low usage line port with Caller ID (LUM) | | | UEPSR | UEPAP | 1.49 | 3.74 | 3.63 | 2.23 | 2.13 | | 7.86 | | | |
| | Exchange Ports - 2-Wire Voice Kentucky Residence Dialing Plan without Caller ID | | | UEPSR | UEPWE | 1.49 | 3.74 | 3.63 | 2.23 | 2.13 | | 7.86 | | | |
| | 2-Wire voice unbundled Low Usage Line Port without Caller ID Capability | | | UEPSR | UEPRT | 1.49 | 3.74 | 3.63 | 2.23 | 2.13 | | 7.86 | | | |
| | Subsequent Activity | | | UEPSR | USASC | 0.00 | 0.00 | 0.00 | | | | 7.86 | | | |
| FEATURES | | | | | | | | | | | | | | | |
| | All Available Vertical Features | | | UEPSR | UEPVF | 0.00 | 0.00 | 0.00 | | | | 7.86 | | | |
| 2-WIRE VOICE GRADE LINE PORT RATES (BUS) | | | | | | | | | | | | | | | |
| | Exchange Ports - 2-Wire Analog Line Port without Caller ID - Bus | | | UEPSB | UEPBL | 1.49 | 3.74 | 3.63 | 2.23 | 2.13 | | 7.86 | | | |
| | Exchange Ports - 2-Wire VG unbundled Line Port with unbundled port with Caller+E484 ID - Bus. | | | UEPSB | UEPBC | 1.49 | 3.74 | 3.63 | 2.23 | 2.13 | | 7.86 | | | |
| | Exchange Ports - 2-Wire Analog Line Port outgoing only - Bus. | | | UEPSB | UEPBO | 1.49 | 3.74 | 3.63 | 2.23 | 2.13 | | 7.86 | | | |
| | Exchange Ports - 2-Wire VG unbundled KY extended local dialing party Port with Caller ID - Bus. | | | UEPSB | UEPBM | 1.49 | 3.74 | 3.63 | 2.23 | 2.13 | | 7.86 | | | |
| | Exchange Ports - 2-Wire VG unbundled incoming only port with Caller ID - Bus | | | UEPSB | UEPB1 | 1.49 | 3.74 | 3.63 | 2.23 | 2.13 | | 7.86 | | | |
| | Exchange Ports - 2-Wire Voice Kentucky Business Dialing Plan without Caller ID | | | UEPSB | UEPWF | 1.49 | 3.74 | 3.63 | 2.23 | 2.13 | | 7.86 | | | |
| | 2-Wire voice unbundled Incoming Only Port without Caller ID Capability | | | UEPSB | UEPBE | 1.49 | 3.74 | 3.63 | 2.23 | 2.13 | | 7.86 | | | |
| | Subsequent Activity | | | UEPSB | USASC | 0.00 | 0.00 | 0.00 | | | | 7.86 | | | |
| FEATURES | | | | | | | | | | | | | | | |
| | All Available Vertical Features | | | UEPSB | UEPVF | 0.00 | 0.00 | 0.00 | | | | 7.86 | | | |
| EXCHANGE PORT RATES (DID & PBX) | | | | | | | | | | | | | | | |
| | 2-Wire VG Unbundled 2-Way PBX Trunk - Res | | | UEPSE | UEPRD | 1.49 | 39.05 | 18.17 | 15.38 | 0.89 | | 7.86 | | | |
| | 2-Wire VG Line Side Unbundled 2-Way PBX Trunk - Bus | | | UEPSP | UEPPC | 1.49 | 39.05 | 18.17 | 15.38 | 0.89 | | 7.86 | | | |
| | 2-Wire VG Line Side Unbundled Outward PBX Trunk - Bus | | | UEPSP | UEPPO | 1.49 | 39.05 | 18.17 | 15.38 | 0.89 | | 7.86 | | | |
| | 2-Wire VG Line Side Unbundled Incoming PBX Trunk - Bus | | | UEPSP | UEPP1 | 1.49 | 39.05 | 18.17 | 15.38 | 0.89 | | 7.86 | | | |
| | 2-Wire Analog Long Distance Terminal PBX Trunk - Bus | | | UEPSP | UEPLD | 1.49 | 39.05 | 18.17 | 15.38 | 0.89 | | 7.86 | | | |
| | 2-Wire Voice Unbundled PBX LD Terminal Ports | | | UEPSP | UEPLD | 1.49 | 39.05 | 18.17 | 15.38 | 0.89 | | 7.86 | | | |
| | 2-Wire Vice Unbundled 2-Way PBX Usage Port | | | UEPSP | UEPXA | 1.49 | 39.05 | 18.17 | 15.38 | 0.89 | | 7.86 | | | |
| | 2-Wire Voice Unbundled PBX Toll Terminal Hotel Ports | | | UEPSP | UEPXB | 1.49 | 39.05 | 18.17 | 15.38 | 0.89 | | 7.86 | | | |
| | 2-Wire Voice Unbundled PBX LD DDD Terminals Port | | | UEPSP | UEPXC | 1.49 | 39.05 | 18.17 | 15.38 | 0.89 | | 7.86 | | | |
| | 2-Wire Voice Unbundled PBX LD Terminal Switchboard Port | | | UEPSP | UEPXD | 1.49 | 39.05 | 18.17 | 15.38 | 0.89 | | 7.86 | | | |
| | 2-Wire Voice Unbundled PBX LD Terminal Switchboard IDD Capable Port | | | UEPSP | UEPXE | 1.49 | 39.05 | 18.17 | 15.38 | 0.89 | | 7.86 | | | |
| | 2-Wire Voice Unbundled 2-Way PBX Kentucky Room Area Calling Port Without LUD | | | UEPSP | UEPXF | 1.49 | 39.05 | 18.17 | 15.38 | 0.89 | | 7.86 | | | |
| | 2-Wire Voice Unbundled PBX Kentucky LUD Area Calling Port | | | UEPSP | UEPXF | 1.49 | 39.05 | 18.17 | 15.38 | 0.89 | | 7.86 | | | |
| | 2-Wire Voice Unbundled PBX Kentucky Premium Calling Port | | | UEPSP | UEPXG | 1.49 | 39.05 | 18.17 | 15.38 | 0.89 | | 7.86 | | | |
| | 2-Wire Voice Unbundled 2-Way PBX Kentucky Area Calling Port Without LUD | | | UEPSP | UEPXJ | 1.49 | 39.05 | 18.17 | 15.38 | 0.89 | | 7.86 | | | |
| | 2-Wire Voice Unbundled 2-Way PBX Hotel/Hospital Economy Administrative Calling Port | | | UEPSP | UEPXL | 1.49 | 39.05 | 18.17 | 15.38 | 0.89 | | 7.86 | | | |
| | 2-Wire Voice Unbundled 2-Way PBX Hotel/Hospital Economy Room Calling Port | | | UEPSP | UEPXM | 1.49 | 39.05 | 18.17 | 15.38 | 0.89 | | 7.86 | | | |
| | 2-Wire Voice Unbundled 1-Way Outgoing PBX Hotel/Hospital Discount Room Calling Port | | | UEPSP | UEPXO | 1.49 | 39.05 | 18.17 | 15.38 | 0.89 | | 7.86 | | | |
| | 2-Wire Voice Unbundled 1-Way Outgoing PBX Measured Port | | | UEPSP | UEPXS | 1.49 | 39.05 | 18.17 | 15.38 | 0.89 | | 7.86 | | | |
| | Subsequent Activity | | | UEPSP | USASC | 0.00 | 0.00 | 0.00 | | | | 7.86 | | | |

| UNBUNDLED NETWORK ELEMENTS - Kentucky | | | | | | | | | | Attachment: 2 | | Exhibit: D | | | |
|--|--|---------|------|-------------|-------|-----------|--------------|-------|-------------------------|----------------------------------|--------------------------------------|--|--|---|---|
| CATEGORY | RATE ELEMENTS | Interim | Zone | BCS | USOC | RATES(\$) | | | | Svc Order Submitted Elec per LSR | Svc Order Submitted Manually per LSR | Incremental Charge - Manual Svc Order vs. Electronic-1st | Incremental Charge - Manual Svc Order vs. Electronic-Add'l | Incremental Charge - Manual Svc Order vs. Electronic-Disc 1st | Incremental Charge - Manual Svc Order vs. Electronic-Disc Add'l |
| | | | | | | Rec | Nonrecurring | | Nonrecurring Disconnect | | | | | | |
| | | | | | | First | Add'l | First | Add'l | SOMEc | SOMAN | SOMAN | SOMAN | SOMAN | SOMAN |
| FEATURES | | | | | | | | | | | | | | | |
| | All Available Vertical Features | | | UEPSP UEPSE | UEPVF | 0.00 | 0.00 | 0.00 | | | | | | | 7.86 |
| EXCHANGE PORT RATES (COIN) | | | | | | | | | | | | | | | |
| | Exchange Ports - Coin Port | | | | | 1.49 | 3.74 | 3.63 | 2.23 | 2.13 | | | | | 7.86 |
| Local Switching Features offered with Port | | | | | | | | | | | | | | | |
| NOTE: Transmission/usage charges associated with POTS circuit switched usage will also apply to circuit switched voice and/or circuit switched data transmission by B-Channels associated with 2-wire ISDN ports. | | | | | | | | | | | | | | | |
| NOTE: Access to B Channel or D Channel Packet capabilities will be available only through BFR/New Business Request Process. Rates for the packet capabilities will be determined via the Bona Fide Request/New Business Request Process. | | | | | | | | | | | | | | | |
| | Exchange port - 4-wire ISDN trunk port -all available features included | | | UEPEX | | 101.60 | 188.36 | 95.15 | 61.92 | 22.67 | | | | | 7.86 |
| UNBUNDLED LOCAL EXCHANGE SWITCHING(PORTS) | | | | | | | | | | | | | | | |
| EXCHANGE PORT RATES | | | | | | | | | | | | | | | |
| | Exchange Ports - 2-Wire DID Port | | | UEPEX | UEPP2 | 10.51 | 92.18 | 15.82 | 52.16 | 5.30 | | | | | 7.86 |
| | Exchange Ports - DDITS Port - 4-Wire DS1 Port with DID capability | | | UEPDD | UEPDD | 74.77 | 164.86 | 77.74 | 60.69 | 3.86 | | | | | 7.86 |
| | Exchange Ports - 2-Wire ISDN Port (See Notes below.) | | | UEPTX UEPSX | U1PMA | 13.46 | 60.60 | 50.67 | 32.83 | 14.17 | | | | | 7.86 |
| | All Features Offered | | | UEPTX UEPSX | UEPVF | 0.00 | 0.00 | 0.00 | | | | | | | |
| NOTE: Transmission/usage charges associated with POTS circuit switched usage will also apply to circuit switched voice and/or circuit switched data transmission by B-Channels associated with 2-wire ISDN ports. | | | | | | | | | | | | | | | |
| NOTE: Access to B Channel or D Channel Packet capabilities will be available only through BFR/New Business Request Process. Rates for the packet capabilities will be determined via the Bona Fide Request/New Business Request Process. | | | | | | | | | | | | | | | |
| | Exchange Ports - 2-Wire ISDN Port -- Channel Profiles | | | UEPTX UEPSX | U1UMA | 0.00 | 0.00 | 0.00 | | | | | | | |
| | Exchange Ports - 4-Wire ISDN DS1 Port | | | UEPEX | UEPEX | 101.60 | 188.36 | 95.15 | 61.92 | 22.67 | | | | | 7.86 |
| UNBUNDLED PORT WITH REMOTE CALL FORWARDING CAPABILITY | | | | | | | | | | | | | | | |
| UNBUNDLED REMOTE CALL FORWARDING SERVICE - RESIDENCE | | | | | | | | | | | | | | | |
| | Unbundled Remote Call Forwarding Service, Area Calling, Res | | | UEPVR | UERAC | 1.49 | 3.74 | 3.63 | | | | | | | 7.86 |
| | Unbundled Remote Call Forwarding Service, Local Calling - Res | | | UEPVR | UERLC | 1.49 | 3.74 | 3.63 | | | | | | | 7.86 |
| | Unbundled Remote Call Forwarding Service, InterLATA - Res | | | UEPVR | UERTE | 1.49 | 3.74 | 3.63 | | | | | | | 7.86 |
| | Unbundled Remote Call Forwarding Service, IntraLATA - Res | | | UEPVR | UERTR | 1.49 | 3.74 | 3.63 | | | | | | | 7.86 |
| Non-Recurring | | | | | | | | | | | | | | | |
| | Unbundled Remote Call Forwarding Service - Conversion - Switch-as-is | | | UEPVR | USAC2 | | 0.10 | 0.10 | | | | | | | 7.86 |
| | Unbundled Remote Call Forwarding Service - Conversion with allowed change (PIC and LPIC) | | | UEPVR | USACC | | 0.10 | 0.10 | | | | | | | |
| UNBUNDLED REMOTE CALL FORWARDING - Bus | | | | | | | | | | | | | | | |
| | Unbundled Remote Call Forwarding Service, Area Calling - Bus | | | UEPVB | UERAC | 1.49 | 3.74 | 3.63 | | | | | | | 7.86 |
| | Unbundled Remote Call Forwarding Service, Local Calling - Bus | | | UEPVB | UERLC | 1.49 | 3.74 | 3.63 | | | | | | | 7.86 |
| | Unbundled Remote Call Forwarding Service, InterLATA - Bus | | | UEPVB | UERTE | 1.49 | 3.74 | 3.63 | | | | | | | 7.86 |
| | Unbundled Remote Call Forwarding Service, IntraLATA - Bus | | | UEPVB | UERTR | 1.49 | 3.74 | 3.63 | | | | | | | 7.86 |
| | Unbundled Remote Call Forwarding Service Expanded and Exception Local Calling | | | UEPVB | UEVJ | 1.49 | 3.74 | 3.63 | | | | | | | 7.86 |
| Non-Recurring | | | | | | | | | | | | | | | |
| | Unbundled Remote Call Forwarding Service - Conversion - Switch-as-is | | | UEPVB | USAC2 | | 0.10 | 0.10 | | | | | | | 7.86 |
| | Unbundled Remote Call Forwarding Service - Conversion with allowed change (PIC and LPIC) | | | UEPVB | USACC | | 0.10 | 0.10 | | | | | | | |
| UNBUNDLED LOCAL SWITCHING, PORT USAGE | | | | | | | | | | | | | | | |
| End Office Switching (Port Usage) | | | | | | | | | | | | | | | |
| | End Office Switching Function, Per MOU | | | | | 0.0011971 | | | | | | | | | |
| | End Office Trunk Port - Shared, Per MOU | | | | | 0.0002112 | | | | | | | | | |
| Tandem Switching (Port Usage) (Local or Access Tandem) | | | | | | | | | | | | | | | |
| | Tandem Switching Function Per MOU | | | | | 0.000194 | | | | | | | | | |
| | Tandem Trunk Port - Shared, Per MOU | | | | | 0.0002416 | | | | | | | | | |
| Common Transport | | | | | | | | | | | | | | | |
| | Common Transport - Per Mile, Per MOU | | | | | 0.000003 | | | | | | | | | |
| | Common Transport - Facilities Termination Per MOU | | | | | 0.0007466 | | | | | | | | | |
| UNBUNDLED PORT/LOOP COMBINATIONS - COST BASED RATES | | | | | | | | | | | | | | | |
| Cost Based Rates are applied where BellSouth is required by FCC and/or State Commission rule to provide Unbundled Local Switching or Switch Ports. | | | | | | | | | | | | | | | |
| Features shall apply to the Unbundled Port/Loop Combination - Cost Based Rate section in the same manner as they are applied to the Stand-Alone Unbundled Port section of this Rate Exhibit. | | | | | | | | | | | | | | | |
| End Office and Tandem Switching Usage and Common Transport Usage rates in the Port section of this rate exhibit shall apply to all combinations of loop/port network elements except for UNE Coin Port/Loop Combinations. | | | | | | | | | | | | | | | |
| The first and additional Port nonrecurring charges apply to Not Currently Combined Combos. For Currently Combined Combos the nonrecurring charges shall be those identified in the Nonrecurring - Currently Combined sections. | | | | | | | | | | | | | | | |
| 2-WIRE VOICE GRADE LOOP WITH 2-WIRE LINE PORT (RES) | | | | | | | | | | | | | | | |
| UNE Port/Loop Combination Rates | | | | | | | | | | | | | | | |
| | 2-Wire VG Loop/Port Combo - Zone 1 | | 1 | | | 10.79 | | | | | | | | | |

| UNBUNDLED NETWORK ELEMENTS - Kentucky | | | | | | | | | | Attachment: 2 | | Exhibit: D | | | | |
|--|---|---------|------|-------|-------|-----------|--------------|-------|-------------------------|----------------------------------|--------------------------------------|--|--|---|---|---------------|
| CATEGORY | RATE ELEMENTS | Interim | Zone | BCS | USOC | RATES(\$) | | | | Svc Order Submitted Elec per LSR | Svc Order Submitted Manually per LSR | Incremental Charge - Manual Svc Order vs. Electronic-1st | Incremental Charge - Manual Svc Order vs. Electronic-Add'l | Incremental Charge - Manual Svc Order vs. Electronic-Disc 1st | Incremental Charge - Manual Svc Order vs. Electronic-Disc Add'l | |
| | | | | | | Rec | Nonrecurring | | Nonrecurring Disconnect | | | | | | | OSS Rates(\$) |
| | | | | | | | First | Add'l | First | Add'l | SOMEc | SOMAN | SOMAN | SOMAN | SOMAN | SOMAN |
| | 2-Wire VG Loop/Port Combo - Zone 2 | | 2 | | | | 15.52 | | | | | | | | | |
| | 2-Wire VG Loop/Port Combo - Zone 3 | | 3 | | | | 31.74 | | | | | | | | | |
| UNE Loop Rates | | | | | | | | | | | | | | | | |
| | 2-Wire Voice Grade Loop (SL1) - Zone 1 | | 1 | UEPRX | UEPLX | | 9.64 | | | | | | | | | |
| | 2-Wire Voice Grade Loop (SL1) - Zone 2 | | 2 | UEPRX | UEPLX | | 14.37 | | | | | | | | | |
| | 2-Wire Voice Grade Loop (SL1) - Zone 3 | | 3 | UEPRX | UEPLX | | 30.59 | | | | | | | | | |
| 2-Wire Voice Grade Line Port Rates (Res) | | | | | | | | | | | | | | | | |
| | 2-Wire voice unbundled port - residence | | | UEPRX | UEPRL | | 1.15 | 21.29 | 15.49 | 2.85 | 2.67 | | 7.86 | | | |
| | 2-Wire voice unbundled port with Caller ID - res | | | UEPRX | UEPRC | | 1.15 | 21.29 | 15.49 | 2.85 | 2.67 | | 7.86 | | | |
| | 2-Wire voice unbundled port outgoing only - res | | | UEPRX | UEPRO | | 1.15 | 21.29 | 15.49 | 2.85 | 2.67 | | 7.86 | | | |
| | 2-Wire voice Grade unbundled Kentucky extended local dialing parity port with Caller ID - res | | | UEPRX | UEPRM | | 1.15 | 21.29 | 15.49 | 2.85 | 2.67 | | 7.86 | | | |
| | 2-Wire voice unbundles res, low usage line port with Caller ID (LUM) | | | UEPRX | UEPAP | | 1.15 | 21.29 | 15.49 | 2.85 | 2.67 | | 7.86 | | | |
| | 2-Wire Voice Unbundled Kentucky Residence Dialing Plan without Caller ID | | | UEPRX | UEPWE | | 1.15 | 21.29 | 15.49 | 2.85 | 2.67 | | 7.86 | | | |
| | 2-Wire voice unbundled Low Usage Line Port without Caller ID Capability | | | UEPRX | UEPRT | | 1.15 | 21.29 | 15.49 | 2.85 | 2.67 | | 7.86 | | | |
| FEATURES | | | | | | | | | | | | | | | | |
| | All Features Offered | | | UEPRX | UEPVF | | 0.00 | 0.00 | 0.00 | | | | 7.86 | | | |
| LOCAL NUMBER PORTABILITY | | | | | | | | | | | | | | | | |
| | Local Number Portability (1 per port) | | | UEPRX | LNPCX | | 0.35 | | | | | | | | | |
| NONRECURRING CHARGES (NRCs) - CURRENTLY COMBINED | | | | | | | | | | | | | | | | |
| | 2-Wire Voice Grade Loop / Line Port Combination - Conversion - Switch-as-is | | | UEPRX | USAC2 | | | 0.10 | 0.10 | | | | 7.86 | | | |
| | 2-Wire Voice Grade Loop / Line Port Combination - Conversion - Switch with change | | | UEPRX | USACC | | | 0.10 | 0.10 | | | | 7.86 | | | |
| ADDITIONAL NRCs | | | | | | | | | | | | | | | | |
| | 2-Wire Voice Grade Loop/Line Port Combination - Subsequent Activity | | | UEPRX | USAS2 | | 0.00 | 0.00 | 0.00 | | | | 7.86 | | | |
| 2-WIRE VOICE GRADE LOOP WITH 2-WIRE LINE PORT (BUS) | | | | | | | | | | | | | | | | |
| UNE Port/Loop Combination Rates | | | | | | | | | | | | | | | | |
| | 2-Wire VG Loop/Port Combo - Zone 1 | | 1 | | | | 10.79 | | | | | | | | | |
| | 2-Wire VG Loop/Port Combo - Zone 2 | | 2 | | | | 15.52 | | | | | | | | | |
| | 2-Wire VG Loop/Port Combo - Zone 3 | | 3 | | | | 31.74 | | | | | | | | | |
| UNE Loop Rates | | | | | | | | | | | | | | | | |
| | 2-Wire Voice Grade Loop (SL1) - Zone 1 | | 1 | UEPBX | UEPLX | | 9.64 | | | | | | | | | |
| | 2-Wire Voice Grade Loop (SL1) - Zone 2 | | 2 | UEPBX | UEPLX | | 14.37 | | | | | | | | | |
| | 2-Wire Voice Grade Loop (SL1) - Zone 3 | | 3 | UEPBX | UEPLX | | 30.59 | | | | | | | | | |
| 2-Wire Voice Grade Line Port (Bus) | | | | | | | | | | | | | | | | |
| | 2-Wire voice unbundled port without Caller ID - bus | | | UEPBX | UEPBL | | 1.15 | 21.29 | 15.49 | 2.85 | 2.67 | | 7.86 | | | |
| | 2-Wire voice unbundled port with Caller + E484 ID - bus | | | UEPBX | UEPBC | | 1.15 | 21.29 | 15.49 | 2.85 | 2.67 | | 7.86 | | | |
| | 2-Wire voice unbundled port outgoing only - bus | | | UEPBX | UEPBO | | 1.15 | 21.29 | 15.49 | 2.85 | 2.67 | | 7.86 | | | |
| | 2-Wire voice Grade unbundled Kentucky extended local dialing parity port with Caller ID - bus | | | UEPBX | UEPBM | | 1.15 | 21.29 | 15.49 | 2.85 | 2.67 | | 7.86 | | | |
| | 2-Wire voice unbundled incoming only port with Caller ID - Bus | | | UEPBX | UEPB1 | | 1.15 | 21.29 | 15.49 | 2.85 | 2.67 | | 7.86 | | | |
| | 2-Wire Voice Unbundled Kentucky Business Dialing Plan without Caller ID | | | UEPBX | UEPWF | | 1.15 | 21.29 | 15.49 | 2.85 | 2.67 | | 7.86 | | | |
| | 2-Wire voice unbundled Incoming Only Port without Caller ID Capability | | | UEPBX | UEPBE | | 1.15 | 21.29 | 15.49 | 2.85 | 2.67 | | 7.86 | | | |
| LOCAL NUMBER PORTABILITY | | | | | | | | | | | | | | | | |
| | Local Number Portability (1 per port) | | | UEPBX | LNPCX | | 0.35 | | | | | | | | | |
| FEATURES | | | | | | | | | | | | | | | | |
| | All Features Offered | | | UEPBX | UEPVF | | 0.00 | 0.00 | 0.00 | | | | 7.86 | | | |
| NONRECURRING CHARGES (NRCs) - CURRENTLY COMBINED | | | | | | | | | | | | | | | | |
| | 2-Wire Voice Grade Loop / Line Port Combination - Conversion - Switch-as-is | | | UEPBX | USAC2 | | | 0.10 | 0.10 | | | | 7.86 | | | |
| | 2-Wire Voice Grade Loop / Line Port Combination - Conversion - Switch with change | | | UEPBX | USACC | | | 0.10 | 0.10 | | | | 7.86 | | | |
| ADDITIONAL NRCs | | | | | | | | | | | | | | | | |
| | 2-Wire Voice Grade Loop/Line Port Combination - Subsequent Activity | | | UEPBX | USAS2 | | | 0.00 | 0.00 | | | | 7.86 | | | |
| 2-WIRE VOICE GRADE LOOP WITH 2-WIRE LINE PORT (RES - PBX) | | | | | | | | | | | | | | | | |
| UNE Port/Loop Combination Rates | | | | | | | | | | | | | | | | |

| UNBUNDLED NETWORK ELEMENTS - Kentucky | | | | | | | | | | | Attachment: 2 | | Exhibit: D | | | | | | | | | |
|---------------------------------------|--|---------|------|-------|-------|-----------|----------------------------------|--------------------------------------|--|--|---|---|---------------|--------------|-------|-------------------------|--|-------|-------|-------|-------|-------|
| CATEGORY | RATE ELEMENTS | Interim | Zone | BCS | USOC | RATES(\$) | Svc Order Submitted Elec per LSR | Svc Order Submitted Manually per LSR | Incremental Charge - Manual Svc Order vs. Electronic-1st | Incremental Charge - Manual Svc Order vs. Electronic-Add'l | Incremental Charge - Manual Svc Order vs. Electronic-Disc 1st | Incremental Charge - Manual Svc Order vs. Electronic-Disc Add'l | OSS Rates(\$) | | | | | | | | | |
| | | | | | | | | | | | | | Rec | Nonrecurring | | Nonrecurring Disconnect | | SOMEc | SOMAN | SOMAN | SOMAN | SOMAN |
| | | | | | | | | | | | | | First | Add'l | First | Add'l | | | | | | |
| | 2-Wire VG Loop/Port Combo - Zone 1 | | 1 | | | 10.79 | | | | | | | | | | | | | | | | |
| | 2-Wire VG Loop/Port Combo - Zone 2 | | 2 | | | 15.52 | | | | | | | | | | | | | | | | |
| | 2-Wire VG Loop/Port Combo - Zone 3 | | 3 | | | 31.74 | | | | | | | | | | | | | | | | |
| | UNE Loop Rates | | | | | | | | | | | | | | | | | | | | | |
| | 2-Wire Voice Grade Loop (SL 1) - Zone 1 | | 1 | UEPRG | UEPLX | 9.64 | | | | | | | | | | | | | | | | |
| | 2-Wire Voice Grade Loop (SL 1) - Zone 2 | | 2 | UEPRG | UEPLX | 14.37 | | | | | | | | | | | | | | | | |
| | 2-Wire Voice Grade Loop (SL 1) - Zone 3 | | 3 | UEPRG | UEPLX | 30.59 | | | | | | | | | | | | | | | | |
| | 2-Wire Voice Grade Line Port Rates (RES - PBX) | | | | | | | | | | | | | | | | | | | | | |
| | 2-Wire VG Unbundled Combination 2-Way PBX Trunk Port - Res | | | UEPRG | UEPRD | 1.15 | 21.29 | 15.49 | 2.85 | 2.67 | | 7.86 | | | | | | | | | | |
| | LOCAL NUMBER PORTABILITY | | | | | | | | | | | | | | | | | | | | | |
| | Local Number Portability (1 per port) | | | UEPRG | LNPCP | 3.15 | 0.00 | 0.00 | | | | 7.86 | | | | | | | | | | |
| | FEATURES | | | | | | | | | | | | | | | | | | | | | |
| | All Features Offered | | | UEPRG | UEPVF | 0.00 | 0.00 | 0.00 | | | | 7.86 | | | | | | | | | | |
| | NONRECURRING CHARGES (NRCs) - CURRENTLY COMBINED | | | | | | | | | | | | | | | | | | | | | |
| | 2-Wire Voice Grade Loop/ Line Port Combination (PBX) - Conversion - Switch-As-Is | | | UEPRG | USAC2 | | 8.45 | 1.91 | | | | 7.86 | | | | | | | | | | |
| | 2-Wire Voice Grade Loop/ Line Port Combination (PBX) - Conversion - Switch with Change | | | UEPRG | USACC | | 8.45 | 1.91 | | | | 7.86 | | | | | | | | | | |
| | ADDITIONAL NRCs | | | | | | | | | | | | | | | | | | | | | |
| | 2-Wire Voice Grade Loop/ Line Port Combination (PBX) - Subsequent Activity | | | UEPRG | USAS2 | 0.00 | 0.00 | 0.00 | | | | 7.86 | | | | | | | | | | |
| | PBX Subsequent Activity - Change/Rearrange Multiline Hunt Group | | | | | | 7.86 | 7.86 | | | | 7.86 | | | | | | | | | | |
| | 2-WIRE VOICE GRADE LOOP WITH 2-WIRE LINE PORT (BUS - PBX) | | | | | | | | | | | | | | | | | | | | | |
| | UNE Port/Loop Combination Rates | | | | | | | | | | | | | | | | | | | | | |
| | 2-Wire VG Loop/Port Combo - Zone 1 | | 1 | | | 10.79 | | | | | | | | | | | | | | | | |
| | 2-Wire VG Loop/Port Combo - Zone 2 | | 2 | | | 15.52 | | | | | | | | | | | | | | | | |
| | 2-Wire VG Loop/Port Combo - Zone 3 | | 3 | | | 31.74 | | | | | | | | | | | | | | | | |
| | UNE Loop Rates | | | | | | | | | | | | | | | | | | | | | |
| | 2-Wire Voice Grade Loop (SL 1) - Zone 1 | | 1 | UEPPX | UEPLX | 9.64 | | | | | | | | | | | | | | | | |
| | 2-Wire Voice Grade Loop (SL 1) - Zone 2 | | 2 | UEPPX | UEPLX | 14.37 | | | | | | | | | | | | | | | | |
| | 2-Wire Voice Grade Loop (SL 1) - Zone 3 | | 3 | UEPPX | UEPLX | 30.59 | | | | | | | | | | | | | | | | |
| | 2-Wire Voice Grade Line Port Rates (BUS - PBX) | | | | | | | | | | | | | | | | | | | | | |
| | Line Side Unbundled Combination 2-Way PBX Trunk Port - Bus | | | UEPPX | UEPPC | 1.15 | 21.29 | 15.49 | 2.85 | 2.67 | | 7.86 | | | | | | | | | | |
| | Line Side Unbundled Outward PBX Trunk Port - Bus | | | UEPPX | UEPPO | 1.15 | 21.29 | 15.49 | 2.85 | 2.67 | | 7.86 | | | | | | | | | | |
| | Line Side Unbundled Incoming PBX Trunk Port - Bus | | | UEPPX | UEPP1 | 1.15 | 21.29 | 15.49 | 2.85 | 2.67 | | 7.86 | | | | | | | | | | |
| | 2-Wire Voice Unbundled PBX LD Terminal Ports | | | UEPPX | UEPLD | 1.15 | 21.29 | 15.49 | 2.85 | 2.67 | | 7.86 | | | | | | | | | | |
| | 2-Wire Voice Unbundled 2-Way Combination PBX Usage Port | | | UEPPX | UEPXA | 1.15 | 21.29 | 15.49 | 2.85 | 2.67 | | 7.86 | | | | | | | | | | |
| | 2-Wire Voice Unbundled PBX Toll Terminal Hotel Ports | | | UEPPX | UEPXB | 1.15 | 21.29 | 15.49 | 2.85 | 2.67 | | 7.86 | | | | | | | | | | |
| | 2-Wire Voice Unbundled PBX LD DDD Terminals Port | | | UEPPX | UEPXC | 1.15 | 21.29 | 15.49 | 2.85 | 2.67 | | 7.86 | | | | | | | | | | |
| | 2-Wire Voice Unbundled PBX LD Terminal Switchboard Port | | | UEPPX | UEPXD | 1.15 | 21.29 | 15.49 | 2.85 | 2.67 | | 7.86 | | | | | | | | | | |
| | 2-Wire Voice Unbundled PBX LD Terminal Switchboard IDD Capable Port | | | UEPPX | UEPXE | 1.15 | 21.29 | 15.49 | 2.85 | 2.67 | | 7.86 | | | | | | | | | | |
| | 2-Wire Voice Unbundled 2-Way PBX Kentucky Room Area Calling Port without LUD | | | UEPPX | UEPXF | 1.15 | 21.29 | 15.49 | 2.85 | 2.67 | | 7.86 | | | | | | | | | | |
| | 2-Wire Voice Unbundled PBX Kentucky LUD Area Calling Port | | | UEPPX | UEPXF | 1.15 | 21.29 | 15.49 | 2.85 | 2.67 | | 7.86 | | | | | | | | | | |
| | 2-Wire Voice Unbundled PBX Kentucky Premium Calling Port | | | UEPPX | UEPXH | 1.15 | 21.29 | 15.49 | 2.85 | 2.67 | | 7.86 | | | | | | | | | | |
| | 2-Wire Voice Unbundled 2-Way Kentucky Area Calling Port without LUD | | | UEPPX | UEPXJ | 1.15 | 21.29 | 15.49 | 2.85 | 2.67 | | 7.86 | | | | | | | | | | |
| | 2-Wire Voice Unbundled 2-Way PBX Hotel/Hospital Economy Administrative Calling Port | | | UEPPX | UEPXL | 1.15 | 21.29 | 15.49 | 2.85 | 2.67 | | 7.86 | | | | | | | | | | |
| | 2-Wire Voice Unbundled 2-Way PBX Hotel/Hospital Economy Room Calling Port | | | UEPPX | UEPXM | 1.15 | 21.29 | 15.49 | 2.85 | 2.67 | | 7.86 | | | | | | | | | | |
| | 2-Wire Voice Unbundled 1-Way Outgoing PBX Hotel/Hospital Discount Room Calling Port | | | UEPPX | UEPXO | 1.15 | 21.29 | 15.49 | 2.85 | 2.67 | | 7.86 | | | | | | | | | | |
| | 2-Wire Voice Unbundled 1-Way Outgoing PBX Measured Port | | | UEPPX | UEPXS | 1.15 | 21.29 | 15.49 | 2.85 | 2.67 | | 7.86 | | | | | | | | | | |
| | LOCAL NUMBER PORTABILITY | | | | | | | | | | | | | | | | | | | | | |
| | Local Number Portability (1 per port) | | | UEPPX | LNPCP | 3.15 | 0.00 | 0.00 | | | | 7.86 | | | | | | | | | | |
| | FEATURES | | | | | | | | | | | | | | | | | | | | | |
| | All Features Offered | | | UEPPX | UEPVF | 0.00 | 0.00 | 0.00 | | | | 7.86 | | | | | | | | | | |
| | NONRECURRING CHARGES (NRCs) - CURRENTLY COMBINED | | | | | | | | | | | | | | | | | | | | | |

| UNBUNDLED NETWORK ELEMENTS - Kentucky | | | | | | | | | | Attachment: 2 | | Exhibit: D | | | | |
|---------------------------------------|--|---------|------|-------|-------|-----------|--------------|-------|-------------------------|----------------------------------|--------------------------------------|--|--|---|---|---------------|
| CATEGORY | RATE ELEMENTS | Interim | Zone | BCS | USOC | RATES(\$) | | | | Svc Order Submitted Elec per LSR | Svc Order Submitted Manually per LSR | Incremental Charge - Manual Svc Order vs. Electronic-1st | Incremental Charge - Manual Svc Order vs. Electronic-Add'l | Incremental Charge - Manual Svc Order vs. Electronic-Disc 1st | Incremental Charge - Manual Svc Order vs. Electronic-Disc Add'l | |
| | | | | | | Rec | Nonrecurring | | Nonrecurring Disconnect | | | | | | | OSS Rates(\$) |
| | | | | | | | First | Add'l | First | Add'l | SOMEC | SOMAN | SOMAN | SOMAN | SOMAN | SOMAN |
| | 2-Wire Voice Grade Loop/ Line Port Combination (PBX) - Conversion - Switch-As-Is | | | UEPPX | USAC2 | | 8.45 | 1.91 | | | | 7.86 | | | | |
| | 2-Wire Voice Grade Loop/ Line Port Combination (PBX) - Conversion - Switch with Change | | | UEPPX | USACC | | 8.45 | 1.91 | | | | 7.86 | | | | |
| | ADDITIONAL NRCs | | | | | | | | | | | | | | | |
| | 2-Wire Voice Grade Loop/ Line Port Combination (PBX) - Subsequent Activity | | | UEPPX | USAS2 | 0.00 | 0.00 | 0.00 | | | | 7.86 | | | | |
| | PBX Subsequent Activity - Change/Rearrange Multiline Hunt Group | | | | | | 7.86 | 7.86 | | | | 7.86 | | | | |
| | 2-WIRE VOICE GRADE LOOP WITH 2-WIRE ANALOG LINE COIN PORT | | | | | | | | | | | | | | | |
| | UNE Port/Loop Combination Rates | | | | | | | | | | | | | | | |
| | 2-Wire VG Coin Port/Loop Combo - Zone 1 | | 1 | | | | | | | | | 10.79 | | | | |
| | 2-Wire VG Coin Port/Loop Combo - Zone 2 | | 2 | | | | | | | | | 15.52 | | | | |
| | 2-Wire VG Coin Port/Loop Combo - Zone 3 | | 3 | | | | | | | | | 31.74 | | | | |
| | UNE Loop Rates | | | | | | | | | | | | | | | |
| | 2-Wire Voice Grade Loop (SL1) - Zone 1 | | 1 | UEPCO | UEPLX | | | | | | | 9.64 | | | | |
| | 2-Wire Voice Grade Loop (SL1) - Zone 2 | | 2 | UEPCO | UEPLX | | | | | | | 14.37 | | | | |
| | 2-Wire Voice Grade Loop (SL1) - Zone 3 | | 3 | UEPCO | UEPLX | | | | | | | 30.59 | | | | |
| | 2-Wire Voice Grade Line Ports (COIN) | | | | | | | | | | | | | | | |
| | 2-Wire Coin 2-Way without Operator Screening and without Blocking (AL, KY, LA, MS) | | | UEPCO | UEPRF | 1.15 | 21.29 | 15.49 | 2.85 | 2.67 | | 7.86 | | | | |
| | 2-Wire Coin 2-Way with Operator Screening (AL, KY) | | | UEPCO | UEPRE | 1.15 | 21.29 | 15.49 | 2.85 | 2.67 | | 7.86 | | | | |
| | 2-Wire Coin 2-Way with Operator Screening and Blocking: 011, 900/976, 1+DDD (AL, KY, LA, MS) | | | UEPCO | UEPRA | 1.15 | 21.29 | 15.49 | 2.85 | 2.67 | | 7.86 | | | | |
| | 2-Wire Coin 2-Way with Operator Screening and 011 Blocking (KY) | | | UEPCO | UEPKA | 1.15 | 21.29 | 15.49 | 2.85 | 2.67 | | 7.86 | | | | |
| | 2-Wire Coin 2-Way with Operator Screening & Blocking: 900/976, 1+DDD, 011+, & Local (AL, KY, LA, MS) | | | UEPCO | UEPCD | 1.15 | 21.29 | 15.49 | 2.85 | 2.67 | | 7.86 | | | | |
| | 2-Wire Coin Outward without Blocking and without Operator Screening (KY, LA, MS) | | | UEPCO | UEPRN | 1.15 | 21.29 | 15.49 | 2.85 | 2.67 | | 7.86 | | | | |
| | 2-Wire Coin Outward with Operator Screening and 011 Blocking (GA, KY, MS) | | | UEPCO | UEPRJ | 1.15 | 21.29 | 15.49 | 2.85 | 2.67 | | 7.86 | | | | |
| | 2-Wire Coin Outward with Operator Screening and Blocking: 011, 900/976, 1+DDD (AL, KY, LA, MS) | | | UEPCO | UEPRH | 1.15 | 21.29 | 15.49 | 2.85 | 2.67 | | 7.86 | | | | |
| | 2-Wire Coin Outward Operator Screening & Blocking: 900/976, 1+DDD, 011+, and Local (AL, KY, LA, MS) | | | UEPCO | UEPCN | 1.15 | 21.29 | 15.49 | 2.85 | 2.67 | | 7.86 | | | | |
| | 2-Wire 2-Way Smartline with 900/976 (all states except LA) | | | UEPCO | UEPCK | 1.15 | 21.29 | 15.49 | 2.85 | 2.67 | | 7.86 | | | | |
| | 2-Wire Coin Outward Smartline with 900/976 (all states except LA) | | | UEPCO | UEPCR | 1.15 | 21.29 | 15.49 | 2.85 | 2.67 | | 7.86 | | | | |
| | ADDITIONAL UNE COIN PORT/LOOP (RC) | | | | | | | | | | | | | | | |
| | UNE Coin Port/Loop Combo Usage (Flat Rate) | | | UEPCO | URECU | 2.57 | 21.29 | 15.49 | 2.85 | 2.67 | | | | | | |
| | LOCAL NUMBER PORTABILITY | | | | | | | | | | | | | | | |
| | Local Number Portability (1 per port) | | | UEPCO | LNPCX | 0.35 | | | | | | | | | | |
| | NONRECURRING CHARGES - CURRENTLY COMBINED | | | | | | | | | | | | | | | |
| | 2-Wire Voice Grade Loop / Line Port Combination - Conversion - Switch-as-is | | | UEPCO | USAC2 | | 0.10 | 0.10 | | | | 7.86 | | | | |
| | 2-Wire Voice Grade Loop / Line Port Combination - Conversion - Switch with change | | | UEPCO | USACC | | 0.10 | 0.10 | | | | 7.86 | | | | |
| | ADDITIONAL NRCs | | | | | | | | | | | | | | | |
| | 2-Wire Voice Grade Loop/Line Port Combination - Subsequent Activity | | | UEPCO | USAS2 | | 0.00 | 0.00 | | | | 7.86 | | | | |
| | 2-WIRE VOICE LOOP/ 2WIRE VOICE GRADE IO TRANSPORT/ 2-WIRE LINE PORT (RES) | | | | | | | | | | | | | | | |
| | UNE Port/Loop Combination Rates | | | | | | | | | | | | | | | |
| | 2-Wire VG Loop/IO Transport/Port Combo - Zone 1 | | 1 | | | | | | | | | 13.90 | | | | |
| | 2-Wire VG Loop/IO Transport/Port Combo - Zone 2 | | 2 | | | | | | | | | 18.68 | | | | |
| | 2-Wire VG Loop/IO Transport/Port Combo - Zone 3 | | 3 | | | | | | | | | 34.45 | | | | |
| | UNE Loop Rates | | | | | | | | | | | | | | | |
| | 2-Wire Voice Grade Loop (SL2) - Zone 1 | | 1 | UEPFR | UECF2 | | | | | | | 12.67 | | | | |
| | 2-Wire Voice Grade Loop (SL2) - Zone 2 | | 2 | UEPFR | UECF2 | | | | | | | 17.45 | | | | |
| | 2-Wire Voice Grade Loop (SL2) - Zone 3 | | 3 | UEPFR | UECF2 | | | | | | | 33.22 | | | | |
| | 2-Wire Voice Grade Line Port Rates (Res) | | | | | | | | | | | | | | | |
| | 2-Wire voice unbundled port - residence | | | UEPFR | UEPRL | 1.23 | 128.96 | 64.11 | 61.92 | 9.97 | | 7.86 | | | | |
| | 2-Wire voice unbundled port with Caller ID - res | | | UEPFR | UEPRC | 1.23 | 128.96 | 64.11 | 61.92 | 9.97 | | 7.86 | | | | |
| | 2-Wire voice unbundled port outgoing only - res | | | UEPFR | UEPRO | 1.23 | 128.96 | 64.11 | 61.92 | 9.97 | | 7.86 | | | | |

| UNBUNDLED NETWORK ELEMENTS - Kentucky | | | | | | | | | | Attachment: 2 | | Exhibit: D | | | | |
|--|---|---------|------|-------|-------|-----------|--------------|-------|-------------------------|----------------------------------|--------------------------------------|--|--|---|---|---------------|
| CATEGORY | RATE ELEMENTS | Interim | Zone | BCS | USOC | RATES(\$) | | | | Svc Order Submitted Elec per LSR | Svc Order Submitted Manually per LSR | Incremental Charge - Manual Svc Order vs. Electronic-1st | Incremental Charge - Manual Svc Order vs. Electronic-Add'l | Incremental Charge - Manual Svc Order vs. Electronic-Disc 1st | Incremental Charge - Manual Svc Order vs. Electronic-Disc Add'l | |
| | | | | | | Rec | Nonrecurring | | Nonrecurring Disconnect | | | | | | | OSS Rates(\$) |
| | | | | | | | First | Add'l | First | Add'l | SOMEc | SOMAN | SOMAN | SOMAN | SOMAN | SOMAN |
| | 2-Wire voice Grade unbundled Kentucky extended local dialing party port with Caller ID - res | | | UEPFR | UEPRM | 1.23 | 128.96 | 64.11 | 61.92 | 9.97 | | 7.86 | | | | |
| | 2-Wire voice unbundles res, low usage line port with Caller ID (LUM) | | | UEPFR | UEPAP | 1.23 | 128.96 | 64.11 | 61.92 | 9.97 | | 7.86 | | | | |
| | 2-Wire Voice Unbundled Kentucky Residence Dialing Plan without Caller ID | | | UEPFR | UEPWE | 1.23 | 128.96 | 64.11 | 61.92 | 9.97 | | 7.86 | | | | |
| INTEROFFICE TRANSPORT | | | | | | | | | | | | | | | | |
| | Interoffice Transport - Dedicated - 2 Wire Voice Grade - Facility Termination | | | UEPFR | U1TV2 | 23.95 | 98.09 | 53.67 | 56.31 | 22.42 | | 7.86 | | | | |
| | Interoffice Transport - Dedicated - 2 Wire Voice Grade - Per Mile or Fraction Mile | | | UEPFR | 1L5XX | 0.0095 | | | | | | | | | | |
| FEATURES | | | | | | | | | | | | | | | | |
| | All Features Offered | | | UEPFR | UEPVF | 0.00 | 0.00 | 0.00 | | | | 7.86 | | | | |
| LOCAL NUMBER PORTABILITY | | | | | | | | | | | | | | | | |
| | Local Number Portability (1 per port) | | | UEPFR | LNPCX | 0.35 | | | | | | | | | | |
| NONRECURRING CHARGES (NRCs) - CURRENTLY COMBINED | | | | | | | | | | | | | | | | |
| | 2-Wire Loop / Dedicated IO Transport / 2 Wire Line Port Combination - Conversion - Switch-as-is | | | UEPFR | USAC2 | | 9.03 | 1.87 | | | | 7.86 | | | | |
| | 2-Wire Loop / Dedicated IO Transport / 2 Wire Line Port Combination - Conversion - Switch-With-Change | | | UEPFR | USACC | | 9.03 | 1.87 | | | | 7.86 | | | | |
| 2-WIRE VOICE LOOP/ 2WIRE VOICE GRADE IO TRANSPORT/ 2-WIRE LINE PORT (BUS) | | | | | | | | | | | | | | | | |
| UNE Port/Loop Combination Rates | | | | | | | | | | | | | | | | |
| | 2-Wire VG Loop/IO Tranport/Port Combo - Zone 1 | | 1 | | | | 13.90 | | | | | | | | | |
| | 2-Wire VG Loop/IO Tranport/Port Combo - Zone 2 | | 2 | | | | 18.68 | | | | | | | | | |
| | 2-Wire VG Loop/IO Tranport/Port Combo - Zone 3 | | 3 | | | | 34.45 | | | | | | | | | |
| UNE Loop Rates | | | | | | | | | | | | | | | | |
| | 2-Wire Voice Grade Loop (SL2) - Zone 1 | | 1 | UEPFB | UECF2 | | 12.67 | | | | | | | | | |
| | 2-Wire Voice Grade Loop (SL2) - Zone 2 | | 2 | UEPFB | UECF2 | | 17.45 | | | | | | | | | |
| | 2-Wire Voice Grade Loop (SL2) - Zone 3 | | 3 | UEPFB | UECF2 | | 33.22 | | | | | | | | | |
| 2-Wire Voice Grade Line Port (Bus) | | | | | | | | | | | | | | | | |
| | 2-Wire voice unbundled port without Caller ID - bus | | | UEPFB | UEPBL | 1.23 | 128.96 | 64.11 | 61.92 | 9.97 | | 7.86 | | | | |
| | 2-Wire voice unbundled port with Caller + E484 ID - bus | | | UEPFB | UEPBC | 1.23 | 128.96 | 64.11 | 61.92 | 9.97 | | 7.86 | | | | |
| | 2-Wire voice unbundled port outgoing only - bus | | | UEPFB | UEPBO | 1.23 | 128.96 | 64.11 | 61.92 | 9.97 | | 7.86 | | | | |
| | 2-Wire voice Grade unbundled Kentucky extended local dialing party port with Caller ID - bus | | | UEPFB | UEPBM | 1.23 | 128.96 | 64.11 | 61.92 | 9.97 | | 7.86 | | | | |
| | 2-Wire voice unbundled incoming only port with Caller ID - Bus | | | UEPFB | UEPB1 | 1.23 | 128.96 | 64.11 | 61.92 | 9.97 | | 7.86 | | | | |
| | 2-Wire Voice Unbundled Kentucky Business Dialing Plan without Caller ID | | | UEPFB | UEPWF | 1.23 | 128.96 | 64.11 | 61.92 | 9.97 | | 7.86 | | | | |
| LOCAL NUMBER PORTABILITY | | | | | | | | | | | | | | | | |
| | Local Number Portability (1 per port) | | | UEPFB | LNPCX | 0.35 | | | | | | | | | | |
| INTEROFFICE TRANSPORT | | | | | | | | | | | | | | | | |
| | Interoffice Transport - Dedicated - 2 Wire Voice Grade - Facility Termination | | | UEPFB | U1TV2 | 23.95 | 98.09 | 53.67 | 56.31 | 22.42 | | 7.86 | | | | |
| | Interoffice Transport - Dedicated - 2 Wire Voice Grade - Per Mile or Fraction Mile | | | UEPFB | 1L5XX | 0.0095 | | | | | | | | | | |
| FEATURES | | | | | | | | | | | | | | | | |
| | All Features Offered | | | UEPFB | UEPVF | 0.00 | 0.00 | 0.00 | | | | 7.86 | | | | |
| NONRECURRING CHARGES (NRCs) - CURRENTLY COMBINED | | | | | | | | | | | | | | | | |
| | 2-Wire Loop / Dedicated IO Transport / 2 Wire Line Port Combination - Conversion - Switch-as-is | | | UEPFB | USAC2 | | 9.03 | 1.87 | | | | 7.86 | | | | |
| | 2-Wire Loop / Dedicated IO Transport / 2 Wire Line Port Combination - Conversion - Switch with change | | | UEPFB | USACC | | 9.03 | 1.87 | | | | 7.86 | | | | |
| 2-WIRE VOICE GRADE LOOP WITH 2-WIRE LINE PORT (BUS - PBX) | | | | | | | | | | | | | | | | |
| UNE Port/Loop Combination Rates | | | | | | | | | | | | | | | | |
| | 2-Wire VG Loop/IO Tranport/Port Combo - Zone 1 | | 1 | | | | 13.90 | | | | | | | | | |
| | 2-Wire VG Loop/IO Tranport/Port Combo - Zone 2 | | 2 | | | | 18.68 | | | | | | | | | |
| | 2-Wire VG Loop/IO Tranport/Port Combo - Zone 3 | | 3 | | | | 34.45 | | | | | | | | | |
| UNE Loop Rates | | | | | | | | | | | | | | | | |
| | 2-Wire Voice Grade Loop (SL2) - Zone 1 | | 1 | UEPFP | UECF2 | | 12.67 | | | | | | | | | |
| | 2-Wire Voice Grade Loop (SL2) - Zone 2 | | 2 | UEPFP | UECF2 | | 17.45 | | | | | | | | | |
| | 2-Wire Voice Grade Loop (SL2) - Zone 3 | | 3 | UEPFP | UECF2 | | 33.22 | | | | | | | | | |
| 2-Wire Voice Grade Line Port Rates (BUS - PBX) | | | | | | | | | | | | | | | | |
| | Line Side Unbundled Combination 2-Way PBX Trunk Port - Bus | | | UEPFP | UEPPC | 1.23 | 164.27 | 78.65 | 75.05 | 8.73 | | 7.86 | | | | |

| UNBUNDLED NETWORK ELEMENTS - Kentucky | | | | | | | | | | Attachment: 2 | | Exhibit: D | | | |
|---------------------------------------|---|---------|------|-------|-------|-----------|--------------|-------|-------------------------|----------------------------------|--------------------------------------|--|--|---|---|
| CATEGORY | RATE ELEMENTS | Interim | Zone | BCS | USOC | RATES(\$) | | | | Svc Order Submitted Elec per LSR | Svc Order Submitted Manually per LSR | Incremental Charge - Manual Svc Order vs. Electronic-1st | Incremental Charge - Manual Svc Order vs. Electronic-Add'l | Incremental Charge - Manual Svc Order vs. Electronic-Disc 1st | Incremental Charge - Manual Svc Order vs. Electronic-Disc Add'l |
| | | | | | | Rec | Nonrecurring | | Nonrecurring Disconnect | | | | | | |
| | | | | | | First | Add'l | First | Add'l | SOMEc | SOMAN | SOMAN | SOMAN | SOMAN | SOMAN |
| | Line Side Unbundled Outward PBX Trunk Port - Bus | | | UEFPF | UEPPO | 1.23 | 164.27 | 78.65 | 75.05 | 8.73 | | | | | |
| | Line Side Unbundled Incoming PBX Trunk Port - Bus | | | UEFPF | UEPP1 | 1.23 | 164.27 | 78.65 | 75.05 | 8.73 | | | | | |
| | 2-Wire Voice Unbundled PBX LD Terminal Ports | | | UEFPF | UEPLD | 1.23 | 164.27 | 78.65 | 75.05 | 8.73 | | | | | |
| | 2-Wire Voice Unbundled 2-Way Combination PBX Usage Port | | | UEFPF | UEPXA | 1.23 | 164.27 | 78.65 | 75.05 | 8.73 | | | | | |
| | 2-Wire Voice Unbundled PBX Toll Terminal Hotel Ports | | | UEFPF | UEPXB | 1.23 | 164.27 | 78.65 | 75.05 | 8.73 | | | | | |
| | 2-Wire Voice Unbundled PBX LD DDD Terminals Port | | | UEFPF | UEPXC | 1.23 | 164.27 | 78.65 | 75.05 | 8.73 | | | | | |
| | 2-Wire Voice Unbundled PBX LD Terminal Switchboard Port | | | UEFPF | UEPXD | 1.23 | 164.27 | 78.65 | 75.05 | 8.73 | | | | | |
| | 2-Wire Voice Unbundled PBX LD Terminal Switchboard IDD Capable Port | | | UEFPF | UEPXE | 1.23 | 164.27 | 78.65 | 75.05 | 8.73 | | | | | |
| | 2-Wire Voice Unbundled 2-Way PBX Kentucky Room Area Calling Port without LUD | | | UEFPF | UEPXF | 1.23 | 164.27 | 78.65 | 75.05 | 8.73 | | | | | |
| | 2-Wire Voice Unbundled PBX Kentucky LUD Area Calling Port | | | UEFPF | UEPXG | 1.23 | 164.27 | 78.65 | 75.05 | 8.73 | | | | | |
| | 2-Wire Voice Unbundled PBX Kentucky Premium Calling Port | | | UEFPF | UEPXH | 1.23 | 164.27 | 78.65 | 75.05 | 8.73 | | | | | |
| | 2-Wire Voice Unbundled 2-Way Kentucky Area Calling Port without LUD | | | UEFPF | UEPXJ | 1.23 | 164.27 | 78.65 | 75.05 | 8.73 | | | | | |
| | 2-Wire Voice Unbundled 2-Way PBX Hotel/Hospital Economy Administrative Calling Port | | | UEFPF | UEPXL | 1.23 | 164.27 | 78.65 | 75.05 | 8.73 | | | | | |
| | 2-Wire Voice Unbundled 2-Way PBX Hotel/Hospital Economy Room Calling Port | | | UEFPF | UEPXM | 1.23 | 164.27 | 78.65 | 75.05 | 8.73 | | | | | |
| | 2-Wire Voice Unbundled 1-Way Outgoing PBX Hotel/Hospital Discount Room Calling Port | | | UEFPF | UEPXO | 1.23 | 164.27 | 78.65 | 75.05 | 8.73 | | | | | |
| | 2-Wire Voice Unbundled 1-Way Outgoing PBX Measured Port | | | UEFPF | UEPXS | 1.23 | 164.27 | 78.65 | 75.05 | 8.73 | | | | | |
| | LOCAL NUMBER PORTABILITY | | | | | | | | | | | | | | |
| | Local Number Portability (1 per port) | | | UEFPF | LNPCP | 3.15 | 0.00 | 0.00 | | | | | | | |
| | INTEROFFICE TRANSPORT | | | | | | | | | | | | | | |
| | Interoffice Transport - Dedicated - 2 Wire Voice Grade - Facility Termination | | | UEFPF | U1TV2 | 23.95 | 98.09 | 53.67 | 56.31 | 22.42 | | | | | |
| | Interoffice Transport - Dedicated - 2 Wire Voice Grade - Per Mile or Fraction Mile | | | UEFPF | 1L5XX | 0.0095 | | | | | | | | | |
| | FEATURES | | | | | | | | | | | | | | |
| | All Features Offered | | | UEFPF | UEPVF | 0.00 | 0.00 | 0.00 | | | | | | | |
| | NONRECURRING CHARGES (NRCs) - CURRENTLY COMBINED | | | | | | | | | | | | | | |
| | 2-Wire Loop / Dedicated IO Transport / 2 Wire Line Port Combination - Conversion - Switch-as-is | | | UEFPF | USAC2 | | 9.03 | 1.87 | | | | | | | |
| | 2-Wire Loop / Dedicated IO Transport / 2 Wire Line Port Combination - Conversion - Switch with change | | | UEFPF | USACC | | 9.03 | 1.87 | | | | | | | |
| | UNBUNDLED PORT/LOOP COMBINATIONS - COST BASED RATES | | | | | | | | | | | | | | |
| | 2-WIRE VOICE GRADE LOOP- BUS ONLY - WITH 2-WIRE DID TRUNK PORT | | | | | | | | | | | | | | |
| | UNE Port/Loop Combination Rates | | | | | | | | | | | | | | |
| | 2-Wire VG Loop/2-Wire DID Trunk Port Combo - UNE Zone 1 | | 1 | | | 21.30 | | | | | | | | | |
| | 2-Wire VG Loop/2-Wire DID Trunk Port Combo - UNE Zone 2 | | 2 | | | 26.08 | | | | | | | | | |
| | 2-Wire VG Loop/2-Wire DID Trunk Port Combo - UNE Zone 3 | | 3 | | | 41.85 | | | | | | | | | |
| | UNE Loop Rates | | | | | | | | | | | | | | |
| | 2-Wire Analog Voice Grade Loop - (SL2) - UNE Zone 1 | | 1 | UEPPX | UECD1 | 12.67 | | | | | | | | | |
| | 2-Wire Analog Voice Grade Loop - (SL2) - UNE Zone 2 | | 2 | UEPPX | UECD1 | 17.45 | | | | | | | | | |
| | 2-Wire Analog Voice Grade Loop - (SL2) - UNE Zone 3 | | 3 | UEPPX | UECD1 | 33.22 | | | | | | | | | |
| | UNE Port Rate | | | | | | | | | | | | | | |
| | Exchange Ports - 2-Wire DID Port | | | UEPPX | UEPD1 | 8.63 | 336.11 | 27.75 | 132.37 | 9.31 | | | | | |
| | NONRECURRING CHARGES - CURRENTLY COMBINED | | | | | | | | | | | | | | |
| | 2-Wire Voice Grade Loop / 2-Wire DID Trunk Port Conversion with BellSouth Allowable Changes | | | UEPPX | USA1C | | 7.85 | 1.87 | | | | | | | |
| | ADDITIONAL NRCs | | | | | | | | | | | | | | |
| | 2-Wire DID Subsequent Activity - Add Trunks, Per Trunk | | | UEPPX | USAS1 | | 32.25 | 32.25 | | | | | | | |
| | Telephone Number/Trunk Group Establishment Charges | | | | | | | | | | | | | | |
| | DID Trunk Termination (One Per Port) | | | UEPPX | NDT | 0.00 | 0.00 | 0.00 | | | | | | | |
| | Additional DID Numbers for each Group of 20 DID Numbers | | | UEPPX | ND4 | 0.00 | 0.00 | 0.00 | | | | | | | |
| | DID Numbers, Non- consecutive DID Numbers , Per Number | | | UEPPX | ND5 | 0.00 | 0.00 | 0.00 | | | | | | | |
| | Reserve Non-Consecutive DID numbers | | | UEPPX | ND6 | 0.00 | 0.00 | 0.00 | | | | | | | |
| | Reserve DID Numbers | | | UEPPX | NDV | 0.00 | 0.00 | 0.00 | | | | | | | |
| | LOCAL NUMBER PORTABILITY | | | | | | | | | | | | | | |
| | Local Number Portability (1 per port) | | | UEPPX | LNPCP | 3.15 | 0.00 | 0.00 | | | | | | | |
| | 2-WIRE ISDN DIGITAL GRADE LOOP WITH 2-WIRE ISDN DIGITAL LINE SIDE PORT | | | | | | | | | | | | | | |
| | UNE Port/Loop Combination Rates | | | | | | | | | | | | | | |

| UNBUNDLED NETWORK ELEMENTS - Kentucky | | | | | | | | | | | Attachment: 2 | | Exhibit: D | | | | | | | | | |
|---|---|---------|------|-------------------|------|-----------|----------------------------------|--------------------------------------|--|--|---|---|---------------|--------------|-------|-------------------------|--|-------|-------|-------|-------|-------|
| CATEGORY | RATE ELEMENTS | Interim | Zone | BCS | USOC | RATES(\$) | Svc Order Submitted Elec per LSR | Svc Order Submitted Manually per LSR | Incremental Charge - Manual Svc Order vs. Electronic-1st | Incremental Charge - Manual Svc Order vs. Electronic-Add'l | Incremental Charge - Manual Svc Order vs. Electronic-Disc 1st | Incremental Charge - Manual Svc Order vs. Electronic-Disc Add'l | OSS Rates(\$) | | | | | | | | | |
| | | | | | | | | | | | | | Rec | Nonrecurring | | Nonrecurring Disconnect | | SOMEC | SOMAN | SOMAN | SOMAN | SOMAN |
| | | | | | | | | | | | | | First | Add'l | First | Add'l | | | | | | |
| | 2W ISDN Digital Grade Loop/2W ISDN Digital Line Side Port - UNE Zone 1 | | 1 | UEPPB UEPPR | | 25.69 | | | | | | | | | | | | | | | | |
| | 2W ISDN Digital Grade Loop/2W ISDN Digital Line Side Port - UNE Zone 2 | | 2 | UEPPB UEPPR | | 31.92 | | | | | | | | | | | | | | | | |
| | 2W ISDN Digital Grade Loop/2W ISDN Digital Line Side Port - UNE Zone 3 | | 3 | UEPPB UEPPR | | 50.21 | | | | | | | | | | | | | | | | |
| UNE Loop Rates | | | | | | | | | | | | | | | | | | | | | | |
| | 2-Wire ISDN Digital Grade Loop - UNE Zone 1 | | 1 | UEPPB UEPPR USL2X | | 16.10 | | | | | | | | | | | | | | | | |
| | 2-Wire ISDN Digital Grade Loop - UNE Zone 2 | | 2 | UEPPB UEPPR USL2X | | 22.33 | | | | | | | | | | | | | | | | |
| | 2-Wire ISDN Digital Grade Loop - UNE Zone 3 | | 3 | UEPPB UEPPR USL2X | | 40.63 | | | | | | | | | | | | | | | | |
| UNE Port Rate | | | | | | | | | | | | | | | | | | | | | | |
| | Exchange Port - 2-Wire ISDN Line Side Port | | | UEPPB UEPPR UEPPB | | 9.59 | 320.53 | 289.13 | 92.19 | 17.56 | | | | | | | | | | | | |
| NONRECURRING CHARGES - CURRENTLY COMBINED | | | | | | | | | | | | | | | | | | | | | | |
| | 2-Wire ISDN Digital Grade Loop / 2-Wire ISDN Line Side Port Combination - Conversion | | | UEPPB UEPPR USACB | | 0.00 | 22.77 | 17.00 | | | | | | | | | | | | | | |
| ADDITIONAL NRCs | | | | | | | | | | | | | | | | | | | | | | |
| LOCAL NUMBER PORTABILITY | | | | | | | | | | | | | | | | | | | | | | |
| | Local Number Portability (1 per port) | | | UEPPB UEPPR LNPCX | | 0.35 | 0.00 | 0.00 | | | | | | | | | | | | | | |
| B-CHANNEL USER PROFILE ACCESS: | | | | | | | | | | | | | | | | | | | | | | |
| | CVS/CSD (DMS/5ESS) | | | UEPPB UEPPR U1UCA | | 0.00 | 0.00 | 0.00 | | | | | | | | | | | | | | |
| | CVS (EWSD) | | | UEPPB UEPPR U1UCB | | 0.00 | 0.00 | 0.00 | | | | | | | | | | | | | | |
| | CSD | | | UEPPB UEPPR U1UCC | | 0.00 | 0.00 | 0.00 | | | | | | | | | | | | | | |
| B-CHANNEL AREA PLUS USER PROFILE ACCESS: (AL,KY,LA,MS SC,MS, & TN) | | | | | | | | | | | | | | | | | | | | | | |
| | CVS/CSD (DMS/5ESS) | | | UEPPB UEPPR U1UCD | | 0.00 | 0.00 | 0.00 | | | | | | | | | | | | | | |
| | CVS (EWSD) | | | UEPPB UEPPR U1UCE | | 0.00 | 0.00 | 0.00 | | | | | | | | | | | | | | |
| | CSD | | | UEPPB UEPPR U1UCF | | 0.00 | 0.00 | 0.00 | | | | | | | | | | | | | | |
| USER TERMINAL PROFILE | | | | | | | | | | | | | | | | | | | | | | |
| | User Terminal Profile (EWSD only) | | | UEPPB UEPPR U1UMA | | 0.00 | 0.00 | 0.00 | | | | | | | | | | | | | | |
| VERTICAL FEATURES | | | | | | | | | | | | | | | | | | | | | | |
| | All Vertical Features - One per Channel B User Profile | | | UEPPB UEPPR UEPVF | | 0.00 | 0.00 | 0.00 | | | | | | | | | | | | | | |
| INTEROFFICE CHANNEL MILEAGE | | | | | | | | | | | | | | | | | | | | | | |
| | Interoffice Channel mileage each, including first mile and facilities termination | | | UEPPB UEPPR M1GNC | | 29.12 | 47.34 | 31.78 | 22.77 | 8.75 | | | | | | | | | | | | |
| | Interoffice Channel mileage each, additional mile | | | UEPPB UEPPR M1GNM | | 0.01 | 0.00 | 0.00 | | | | | | | | | | | | | | |
| 4-WIRE DS1 DIGITAL LOOP WITH 4-WIRE ISDN DS1 DIGITAL TRUNK PORT | | | | | | | | | | | | | | | | | | | | | | |
| UNE Port/Loop Combination Rates | | | | | | | | | | | | | | | | | | | | | | |
| | 4W DS1 Digital Loop/4W ISDN DS1 Digital Trunk Port - UNE Zone 1 | | 1 | UEPPP | | 170.06 | | | | | | | | | | | | | | | | |
| | 4W DS1 Digital Loop/4W ISDN DS1 Digital Trunk Port - UNE Zone 2 | | 2 | UEPPP | | 197.70 | | | | | | | | | | | | | | | | |
| | 4W DS1 Digital Loop/4W ISDN DS1 Digital Trunk Port - UNE Zone 3 | | 3 | UEPPP | | 381.35 | | | | | | | | | | | | | | | | |
| UNE Loop Rates | | | | | | | | | | | | | | | | | | | | | | |
| | 4-Wire DS1 Digital Loop - UNE Zone 1 | | 1 | UEPPP USL4P | | 86.47 | | | | | | | | | | | | | | | | |
| | 4-Wire DS1 Digital Loop - UNE Zone 2 | | 2 | UEPPP USL4P | | 114.10 | | | | | | | | | | | | | | | | |
| | 4-Wire DS1 Digital Loop - UNE Zone 3 | | 3 | UEPPP USL4P | | 297.76 | | | | | | | | | | | | | | | | |
| UNE Port Rate | | | | | | | | | | | | | | | | | | | | | | |
| | Exchange Ports - 4-Wire ISDN DS1 Port | | | UEPPP UEPPP | | 83.59 | 736.16 | 382.74 | 159.48 | 48.82 | | | | | | | | | | | | |
| NONRECURRING CHARGES - CURRENTLY COMBINED | | | | | | | | | | | | | | | | | | | | | | |
| | 4-Wire DS1 Digital Loop / 4-Wire ISDN DS1 Digital Trunk Port Combination - Conversion -Switch-as-is | | | UEPPP USACP | | 0.00 | 81.70 | 61.37 | | | | | | | | | | | | | | |
| ADDITIONAL NRCs | | | | | | | | | | | | | | | | | | | | | | |
| | 4-Wire DS1 Loop/4-W ISDN Digtl Trk Port - Subsqst Actvy-Inward/two way Tel Nos. (except NC) | | | UEPPP PR7TF | | | 0.54 | | | | | | | | | | | | | | | |
| | 4-Wire DS1 Loop / 4-Wire ISDN DS1 Digital Trunk Port - Outward Tel Numbers (All States except NC) | | | UEPPP PR7TO | | | 12.71 | 12.71 | | | | | | | | | | | | | | |
| | 4-Wire DS1 Loop / 4-Wire ISDN DS1 Digital Trk Port - Subsequent Inward Tel Numbers | | | UEPPP PR7ZT | | | 25.41 | 25.41 | | | | | | | | | | | | | | |
| LOCAL NUMBER PORTABILITY | | | | | | | | | | | | | | | | | | | | | | |
| | Local Number Portability (1 per port) | | | UEPPP LNPCN | | 1.75 | | | | | | | | | | | | | | | | |
| INTERFACE (Provisioning Only) | | | | | | | | | | | | | | | | | | | | | | |
| | Voice/Data | | | UEPPP PR71V | | 0.00 | 0.00 | 0.00 | | | | | | | | | | | | | | |
| | Digital Data | | | UEPPP PR71D | | 0.00 | 0.00 | 0.00 | | | | | | | | | | | | | | |

| UNBUNDLED NETWORK ELEMENTS - Kentucky | | | | | | | | | | | Attachment: 2 | | Exhibit: D | | | |
|---------------------------------------|--|---------|------|-------|-------|-----------|--------------|--------|-------------------------|----------------------------------|--------------------------------------|--|--|---|---|---------------|
| CATEGORY | RATE ELEMENTS | Interim | Zone | BCS | USOC | RATES(\$) | | | | Svc Order Submitted Elec per LSR | Svc Order Submitted Manually per LSR | Incremental Charge - Manual Svc Order vs. Electronic-1st | Incremental Charge - Manual Svc Order vs. Electronic-Add'l | Incremental Charge - Manual Svc Order vs. Electronic-Disc 1st | Incremental Charge - Manual Svc Order vs. Electronic-Disc Add'l | |
| | | | | | | Rec | Nonrecurring | | Nonrecurring Disconnect | | | | | | | OSS Rates(\$) |
| | | | | | | | First | Add'l | First | Add'l | SOMEK | SOMAN | SOMAN | SOMAN | SOMAN | SOMAN |
| | Inward Data | | | UEPPP | PR71E | 0.00 | 0.00 | 0.00 | | | | | | | | |
| | New or Additional "B" Channel | | | | | | | | | | | | | | | |
| | New or Additional - Voice/Data B Channel | | | UEPPP | PR7BV | 0.00 | 15.48 | | | | | 7.86 | | | | |
| | New or Additional - Digital Data B Channel | | | UEPPP | PR7BF | 0.00 | 15.48 | | | | | 7.86 | | | | |
| | New or Additional Inward Data B Channel | | | UEPPP | PR7BD | 0.00 | 15.48 | | | | | 7.86 | | | | |
| | CALL TYPES | | | | | | | | | | | | | | | |
| | Inward | | | UEPPP | PR7C1 | 0.00 | 0.00 | 0.00 | | | | | | | | |
| | Outward | | | UEPPP | PR7C0 | 0.00 | 0.00 | 0.00 | | | | | | | | |
| | Two-way | | | UEPPP | PR7CC | 0.00 | 0.00 | 0.00 | | | | | | | | |
| | Interoffice Channel Mileage | | | | | | | | | | | | | | | |
| | Fixed Each Including First Mile | | | UEPPP | 1LN1A | 96.27 | 105.52 | 98.46 | 23.09 | 20.49 | | 7.86 | | | | |
| | Each Airline-Fractional Additional Mile | | | UEPPP | 1LN1B | 0.23 | | | | | | | | | | |
| | 4-WIRE DS1 DIGITAL LOOP WITH 4-WIRE DDITS TRUNK PORT | | | | | | | | | | | | | | | |
| | UNE Port/Loop Combination Rates | | | | | | | | | | | | | | | |
| | 4W DS1 Digital Loop/4W DDITS Trunk Port - UNE Zone 1 | | 1 | UEPDC | | 147.99 | | | | | | | | | | |
| | 4W DS1 Digital Loop/4W DDITS Trunk Port - UNE Zone 2 | | 2 | UEPDC | | 175.62 | | | | | | | | | | |
| | 4W DS1 Digital Loop/4W DDITS Trunk Port - UNE Zone 3 | | 3 | UEPDC | | 359.28 | | | | | | | | | | |
| | UNE Loop Rates | | | | | | | | | | | | | | | |
| | 4-Wire DS1 Digital Loop - UNE Zone 1 | | 1 | UEPDC | USLDC | 86.47 | | | | | | 7.86 | | | | |
| | 4-Wire DS1 Digital Loop - UNE Zone 2 | | 2 | UEPDC | USLDC | 114.10 | | | | | | 7.86 | | | | |
| | 4-Wire DS1 Digital Loop - UNE Zone 3 | | 3 | UEPDC | USLDC | 297.76 | | | | | | 7.86 | | | | |
| | UNE Port Rate | | | | | | | | | | | | | | | |
| | 4-Wire DDITS Digital Trunk Port | | | UEPDC | UDD1T | 61.52 | 780.61 | 375.52 | 176.19 | 16.98 | | 7.86 | | | | |
| | NONRECURRING CHARGES - CURRENTLY COMBINED | | | | | | | | | | | | | | | |
| | 4-Wire DS1 Digital Loop / 4-Wire DDITS Trunk Port Combination - Switch-as-is | | | UEPDC | USAC4 | | 92.84 | 46.70 | | | | 7.86 | | | | |
| | 4-Wire DS1 Digital Loop / 4-Wire DDITS Trunk Port Combination - Conversion with DS1 Changes | | | UEPDC | USAWA | | 92.84 | 46.70 | | | | 7.86 | | | | |
| | 4-Wire DS1 Digital Loop / 4-Wire DDITS Trunk Port Combination - Conversion with Change - Trunk | | | UEPDC | USAWB | | 92.84 | 46.70 | | | | 7.86 | | | | |
| | ADDITIONAL NRCS | | | | | | | | | | | | | | | |
| | 4-Wire DS1 Loop / 4-Wire DDITS Trunk Port - NRC - Subsequent Channel Activation/Chan - 2-Way Trunk | | | UEPDC | UDTTA | | 15.09 | 15.09 | | | | 7.86 | | | | |
| | 4-Wire DS1 Loop / 4-Wire DDITS Trunk Port - Subsequent Channel Activation/Chan - 1-Way Outward Trunk | | | UEPDC | UDTTB | | 15.09 | 15.09 | | | | 7.86 | | | | |
| | 4-Wire DS1 Loop / 4-Wire DDITS Trunk Port - Subsqt Channel Activation/Chan Inward Trunk w/out DID | | | UEPDC | UDTTC | | 15.09 | 15.09 | | | | 7.86 | | | | |
| | 4-Wire DS1 Loop / 4-Wire DDITS Trunk Port - Subsqt Chan Activation Per Chan - Inward Trunk with DID | | | UEPDC | UDTTD | | 15.09 | 15.09 | | | | 7.86 | | | | |
| | 4-Wire DS1 Loop / 4-Wire DDITS Trunk Port - Subsqt Chan Activation / Chan - 2-Way DID w User Trans | | | UEPDC | UDTTE | | 15.09 | 15.09 | | | | 7.86 | | | | |
| | BIPOLAR 8 ZERO SUBSTITUTION | | | | | | | | | | | | | | | |
| | B8ZS - Superframe Format | | | UEPDC | CCOSF | | 0.00 | 730.00 | | | | 7.86 | | | | |
| | B8ZS - Extended Superframe Format | | | UEPDC | CCOEF | | 0.00 | 730.00 | | | | 7.86 | | | | |
| | Alternate Mark Inversion | | | | | | | | | | | | | | | |
| | AMI - Superframe Format | | | UEPDC | MCOSF | | 0.00 | 0.00 | | | | | | | | |
| | AMI - Extended SuperFrame Format | | | UEPDC | MCOPO | | 0.00 | 0.00 | | | | | | | | |
| | Telephone Number/Trunk Group Establishment Charges | | | | | | | | | | | | | | | |
| | Telephone Number for 2-Way Trunk Group | | | UEPDC | UDTGX | 0.00 | 0.00 | 0.00 | | | | 7.86 | | | | |
| | Telephone Number for 1-Way Outward Trunk Group | | | UEPDC | UDTGY | 0.00 | | 0.00 | | | | 7.86 | | | | |
| | Telephone Number for 1-Way Inward Trunk Group Without DID | | | UEPDC | UDTGZ | 0.00 | 0.00 | 0.00 | | | | 7.86 | | | | |
| | DID Numbers for each Group of 20 DID Numbers | | | UEPDC | ND4 | 0.00 | 0.00 | 0.00 | | | | 7.86 | | | | |
| | DID Numbers, Non- consecutive DID Numbers , Per Number | | | UEPDC | ND5 | 0.00 | 0.00 | 0.00 | | | | 7.86 | | | | |
| | Reserve Non-Consecutive DID Nos. | | | UEPDC | ND6 | 0.00 | 0.00 | 0.00 | | | | 7.86 | | | | |
| | Reserve DID Numbers | | | UEPDC | NDV | 0.00 | 0.00 | 0.00 | | | | 7.86 | | | | |
| | Dedicated DS1 (Interoffice Channel Mileage) - FX/FCO for 4-Wire DS1 Digital Loop with 4-Wire DDITS Trunk Port | | | | | | | | | | | | | | | |
| | Interoffice Channel Mileage - Fixed rate 0-8 miles (Facilities Termination) | | | UEPDC | 1LNO1 | 96.04 | 105.52 | 98.46 | 23.09 | 20.49 | | 7.86 | | | | |
| | Interoffice Channel Mileage - Additional rate per mile - 0-8 miles | | | UEPDC | 1LNOA | 0.23 | 0.00 | 0.00 | | | | | | | | |
| | Interoffice Channel Mileage - Fixed rate 9-25 miles (Facilities Termination) | | | UEPDC | 1LNO2 | 0.00 | 0.00 | 0.00 | | | | | | | | |
| | Interoffice Channel Mileage - Additional rate per mile - 9-25 miles | | | UEPDC | 1LNOB | 0.45 | 0.00 | 0.00 | | | | | | | | |

| UNBUNDLED NETWORK ELEMENTS - Kentucky | | | | | | | | | | Attachment: 2 | | Exhibit: D | | | |
|--|---|---------|------|-------|-------|-----------|--------------|--------|-------------------------|----------------------------------|--------------------------------------|--|--|---|---|
| CATEGORY | RATE ELEMENTS | Interim | Zone | BCS | USOC | RATES(\$) | | | | Svc Order Submitted Elec per LSR | Svc Order Submitted Manually per LSR | Incremental Charge - Manual Svc Order vs. Electronic-1st | Incremental Charge - Manual Svc Order vs. Electronic-Add'l | Incremental Charge - Manual Svc Order vs. Electronic-Disc 1st | Incremental Charge - Manual Svc Order vs. Electronic-Disc Add'l |
| | | | | | | Rec | Nonrecurring | | Nonrecurring Disconnect | | | | | | |
| | | | | | | First | Add'l | First | Add'l | SOMEC | SOMAN | SOMAN | SOMAN | SOMAN | SOMAN |
| | Interoffice Channel Mileage - Fixed rate 25+ miles (Facilities Termination) | | | UEPDC | 1LNO3 | 0.00 | 0.00 | | | | | | | | |
| | Interoffice Channel Mileage - Additional rate per mile - 25+ miles | | | UEPDC | 1LNOC | 0.45 | 0.00 | | | | | | | | |
| | Local Number Portability, per DS0 Activated | | | UEPDC | LNPCP | 3.15 | 0.00 | | | | | | | | |
| | Central Office Terminating Point | | | UEPDC | CTG | 0.00 | | | | | | | | | |
| 4-WIRE DS1 LOOP WITH CHANNELIZATION WITH PORT | | | | | | | | | | | | | | | |
| System is 1 DS1 Loop, 1 D4 Channel Bank, and up to 24 Feature Activations | | | | | | | | | | | | | | | |
| Each System can have up to 24 combinations of rates depending on type and number of ports used | | | | | | | | | | | | | | | |
| UNE DS1 Loop | | | | | | | | | | | | | | | |
| | 4-Wire DS1 Loop - UNE Zone 1 | | 1 | UEPMG | USLDC | 86.47 | 0.00 | 0.00 | | | | | | | |
| | 4-Wire DS1 Loop - UNE Zone 2 | | 2 | UEPMG | USLDC | 114.10 | 0.00 | 0.00 | | | | | | | |
| | 4-Wire DS1 Loop - UNE Zone 3 | | 3 | UEPMG | USLDC | 297.76 | 0.00 | 0.00 | | | | | | | |
| UNE DSO Channelization Capacities (D4 Channel Bank Configurations) | | | | | | | | | | | | | | | |
| | 24 DSO Channel Capacity - 1 per DS1 | | | UEPMG | VUM24 | 111.16 | 0.00 | 0.00 | | | | 7.86 | | | |
| | 48 DSO Channel Capacity - 1 per 2 DS1s | | | UEPMG | VUM48 | 222.32 | 0.00 | 0.00 | | | | 7.86 | | | |
| | 96 DSO Channel Capacity -1per 4 DS1s | | | UEPMG | VUM96 | 444.64 | 0.00 | 0.00 | | | | 7.86 | | | |
| | 144 DSO Channel Capacity - 1 per 6 DS1s | | | UEPMG | VUM14 | 666.96 | 0.00 | 0.00 | | | | 7.86 | | | |
| | 192 DSO Channel Capacity -1 per 8 DS1s | | | UEPMG | VUM19 | 889.28 | 0.00 | 0.00 | | | | 7.86 | | | |
| | 240 DSO Channel Capacity - 1 per 10 DS1s | | | UEPMG | VUM20 | 1,111.60 | 0.00 | 0.00 | | | | 7.86 | | | |
| | 288 DSO Channel Capacity - 1 per 12 DS1s | | | UEPMG | VUM28 | 1,333.92 | 0.00 | 0.00 | | | | 7.86 | | | |
| | 384 DSO Channel Capacity - 1 per 16 DS1s | | | UEPMG | VUM38 | 1,778.56 | 0.00 | 0.00 | | | | 7.86 | | | |
| | 480 DSO Channel Capacity - 1 per 20 DS1s | | | UEPMG | VUM40 | 2,223.20 | 0.00 | 0.00 | | | | 7.86 | | | |
| | 576 DSO Channel Capacity -1 per 24 DS1s | | | UEPMG | VUM57 | 2,667.84 | 0.00 | 0.00 | | | | 7.86 | | | |
| | 672 DSO Channel Capacity - 1 per 28 DS1s | | | UEPMG | VUM67 | 3,112.48 | 0.00 | 0.00 | | | | 7.86 | | | |
| Non-Recurring Charges (NRC) Associated with 4-Wire DS1 Loop with Channelization with Port - Conversion Charge Based on a System | | | | | | | | | | | | | | | |
| A Minimum System configuration is One (1) DS1, One (1) D4 Channel Bank, and Up To 24 DSO Ports with Feature Activations. | | | | | | | | | | | | | | | |
| Multiples of this configuration functioning as one are considered Add'l after the minimum system configuration is counted. | | | | | | | | | | | | | | | |
| | NRC - Conversion (Currently Combined) with or without BellSouth Allowed Changes | | | UEPMG | USAC4 | 0.00 | 94.30 | 4.24 | | | | 7.86 | | | |
| System Additions at End User Locations Where 4-Wire DS1 Loop with Channelization with Port Combination Currently Exists and | | | | | | | | | | | | | | | |
| New (Not Currently Combined) in all states, except in Density Zone 1 of Top 8 MSA's | | | | | | | | | | | | | | | |
| | 1 DS1/D4 Channel Bank - Additionally Add NRC for each Port and Assoc Fea Activation | | | UEPMG | VUMD4 | 0.00 | 718.89 | 469.86 | 149.83 | 17.77 | | 7.86 | | | |
| Bipolar 8 Zero Substitution | | | | | | | | | | | | | | | |
| | Clear Channel Capability Format, superframe - Subsequent Activity Only | | | UEPMG | CCOSF | 0.00 | 0.00 | 730.00 | | | | 7.86 | | | |
| | Clear Channel Capability Format - Extended Superframe - Subsequent Activity Only | | | UEPMG | CCOEF | 0.00 | 0.00 | 730.00 | | | | 7.86 | | | |
| Alternate Mark Inversion (AMI) | | | | | | | | | | | | | | | |
| | Superframe Format | | | UEPMG | MCOSF | 0.00 | 0.00 | 0.00 | | | | | | | |
| | Extended Superframe Format | | | UEPMG | MCOPO | 0.00 | 0.00 | 0.00 | | | | | | | |
| Exchange Ports Associated with 4-Wire DS1 Loop with Channelization with Port | | | | | | | | | | | | | | | |
| Exchange Ports | | | | | | | | | | | | | | | |
| | Line Side Combination Channelized PBX Trunk Port - Business | | | UEPPX | UEPCX | 1.15 | 0.00 | 0.00 | 0.00 | 0.00 | | 7.86 | | | |
| | Line Side Outward Channelized PBX Trunk Port - Business | | | UEPPX | UEPOX | 1.15 | 0.00 | 0.00 | 0.00 | 0.00 | | 7.86 | | | |
| | Line Side Inward Only Channelized PBX Trunk Port without DID | | | UEPPX | UEPIX | 1.15 | 0.00 | 0.00 | 0.00 | 0.00 | | 7.86 | | | |
| | 2-Wire Trunk Side Unbundled Channelized DID Trunk Port | | | UEPPX | UEPDM | 8.65 | 0.00 | 0.00 | 0.00 | 0.00 | | 7.86 | | | |
| Feature Activations - Unbundled Loop Concentration | | | | | | | | | | | | | | | |
| | Feature (Service) Activation for each Line Port Terminated in D4 Bank | | | UEPPX | 1PQWM | 0.62 | 25.40 | 13.41 | 4.17 | 4.15 | | 7.86 | | | |
| | Feature (Service) Activation for each Trunk Port Terminated in D4 Bank | | | UEPPX | 1PQUW | 0.62 | 78.15 | 19.68 | 59.05 | 11.54 | | 7.86 | | | |
| Telephone Number/ Group Establishment Charges for DID Service | | | | | | | | | | | | | | | |
| | DID Trunk Termination (1 per Port) | | | UEPPX | NDT | 0.00 | 0.00 | 0.00 | | | | 7.86 | | | |
| | DID Numbers - groups of 20 - Valid all States | | | UEPPX | ND4 | 0.00 | 0.00 | 0.00 | | | | 7.86 | | | |
| | Non-Consecutive DID Numbers - per number | | | UEPPX | ND5 | 0.00 | 0.00 | 0.00 | | | | 7.86 | | | |
| | Reserve Non-Consecutive DID Numbers | | | UEPPX | ND6 | 0.00 | 0.00 | 0.00 | | | | 7.86 | | | |
| | Reserve DID Numbers | | | UEPPX | NDV | 0.00 | 0.00 | 0.00 | | | | 7.86 | | | |
| Local Number Portability | | | | | | | | | | | | | | | |
| | Local Number Portability - 1 per port | | | UEPPX | LNPCP | 3.15 | 0.00 | 0.00 | | | | | | | |
| FEATURES - Vertical and Optional | | | | | | | | | | | | | | | |

| UNBUNDLED NETWORK ELEMENTS - Kentucky | | | | | | | | | | Attachment: 2 | | Exhibit: D | | | | |
|--|---|---------|------|-------|-------|-----------|--------------|-------|-------------------------|----------------------------------|--------------------------------------|--|---|---|---------------|-------|
| CATEGORY | RATE ELEMENTS | Interim | Zone | BCS | USOC | RATES(\$) | | | | Svc Order Submitted Elec per LSR | Svc Order Submitted Manually per LSR | Incremental Charge - Manual Svc Order vs. Electronic-1st | Incremental Charge - Manual Svc Order vs. Electronic-Disc 1st | Incremental Charge - Manual Svc Order vs. Electronic-Disc Add'l | | |
| | | | | | | Rec | Nonrecurring | | Nonrecurring Disconnect | | | | | | OSS Rates(\$) | |
| | | | | | | | First | Add'l | First | Add'l | SOMEC | SOMAN | SOMAN | SOMAN | SOMAN | SOMAN |
| | Local Switching Features Offered with Line Side Ports Only | | | | | | | | | | | | | | | |
| | All Features Available | | | UEPPX | UEPVF | 0.00 | 0.00 | 0.00 | | | | | | | | |
| UNBUNDLED CENTREX PORT/LOOP COMBINATIONS - COST BASED RATES | | | | | | | | | | | | | | | | |
| 1. Cost Based Rates are applied where BellSouth is required by FCC and/or State Commission rule to provide Unbundled Local Switching or Switch Ports. | | | | | | | | | | | | | | | | |
| 2. Features shall apply to the Unbundled Port/Loop Combination - Cost Based Rate section in the same manner as they are applied to the Stand-Alone Unbundled Port section of this Rate Exhibit. | | | | | | | | | | | | | | | | |
| 3. End Office and Tandem Switching Usage and Common Transport Usage rates in the Port section of this rate exhibit shall apply to all combinations of loop/port network elements except for UNE Coin Port/Loop Combinations. | | | | | | | | | | | | | | | | |
| 4. The first and additional Port nonrecurring charges apply to Not Currently Combined Combos. For Currently Combined Combos, the nonrecurring charges shall be those identified in the Nonrecurring - Currently Combined sections. Additional NRCs may apply also and are categorized accordingly. | | | | | | | | | | | | | | | | |
| 5. Market Rates for Unbundled Centrex Port/Loop Combination will be negotiated on an Individual Case Basis, until further notice. | | | | | | | | | | | | | | | | |
| UNE-P CENTREX - 1AESS - (Valid in AL,FL,GA,KY,LA,MS,&TN only) | | | | | | | | | | | | | | | | |
| 2-Wire VG Loop/2-Wire Voice Grade Port (Centrex) Combo | | | | | | | | | | | | | | | | |
| UNE Port/Loop Combination Rates (Non-Design) | | | | | | | | | | | | | | | | |
| | 2-Wire VG Loop/2-Wire Voice Grade Port (Centrex) Port Combo - Non-Design | | 1 | UEP91 | | 10.79 | | | | | | | | | | |
| | 2-Wire VG Loop/2-Wire Voice Grade Port (Centrex)Port Combo - Non-Design | | 2 | UEP91 | | 15.52 | | | | | | | | | | |
| | 2-Wire VG Loop/2-Wire Voice Grade Port (Centrex)Port Combo - Non-Design | | 3 | UEP91 | | 31.74 | | | | | | | | | | |
| UNE Port/Loop Combination Rates (Design) | | | | | | | | | | | | | | | | |
| | 2-Wire VG Loop/2-Wire Voice Grade Port (Centrex) Port Combo - Design | | 1 | UEP91 | | 13.82 | | | | | | | | | | |
| | 2-Wire VG Loop/2-Wire Voice Grade Port (Centrex)Port Combo - Design | | 2 | UEP91 | | 18.60 | | | | | | | | | | |
| | 2-Wire VG Loop/2-Wire Voice Grade Port (Centrex)Port Combo - Design | | 3 | UEP91 | | 34.37 | | | | | | | | | | |
| UNE Loop Rate | | | | | | | | | | | | | | | | |
| | 2-Wire Voice Grade Loop (SL 1) - Zone 1 | | 1 | UEP91 | UECS1 | 9.64 | | | | | | 7.86 | | | | |
| | 2-Wire Voice Grade Loop (SL 1) - Zone 2 | | 2 | UEP91 | UECS1 | 14.37 | | | | | | 7.86 | | | | |
| | 2-Wire Voice Grade Loop (SL 1) - Zone 3 | | 3 | UEP91 | UECS1 | 30.59 | | | | | | 7.86 | | | | |
| | 2-Wire Voice Grade Loop (SL 2) - Zone 1 | | 1 | UEP91 | UECS2 | 12.67 | | | | | | 7.86 | | | | |
| | 2-Wire Voice Grade Loop (SL 2) - Zone 2 | | 2 | UEP91 | UECS2 | 17.45 | | | | | | 7.86 | | | | |
| | 2-Wire Voice Grade Loop (SL 2) - Zone 3 | | 3 | UEP91 | UECS2 | 33.22 | | | | | | 7.86 | | | | |
| UNE Ports | | | | | | | | | | | | | | | | |
| All States (Except North Carolina and Sout Carolina) | | | | | | | | | | | | | | | | |
| | 2-Wire Voice Grade Port (Centrex) Basic Local Area | | | UEP91 | UEPYA | 1.15 | 21.29 | 15.49 | 2.85 | 2.67 | | 7.86 | | | | |
| | 2-Wire Voice Grade Port (Centrex 800 termination)Basic Local Area | | | UEP91 | UEPYB | 1.15 | 21.29 | 15.49 | 2.85 | 2.67 | | 7.86 | | | | |
| | 2-Wire Voice Grade Port (Centrex with Caller ID)1Basic Local Area | | | UEP91 | UEPYH | 1.15 | 21.29 | 15.49 | 2.85 | 2.67 | | 7.86 | | | | |
| | 2-Wire Voice Grade Port (Centrex from diff Serving Wire Center)2 Basic Local Area | | | UEP91 | UEPYM | 1.15 | 21.29 | 15.49 | 2.85 | 2.67 | | 7.86 | | | | |
| | 2-Wire Voice Grade Port, Diff Serving Wire Center - 800 Service Term - Basic Local Area | | | UEP91 | UEPYZ | 1.15 | 21.29 | 15.49 | 2.85 | 2.67 | | 7.86 | | | | |
| | 2-Wire Voice Grade Port terminated in on Megalink or equivalent - Basic Local Area | | | UEP91 | UEPY9 | 1.15 | 21.29 | 15.49 | 2.85 | 2.67 | | 7.86 | | | | |
| | 2-Wire Voice Grade Port Terminated on 800 Service Term - Basic Local Area | | | UEP91 | UEPY2 | 1.15 | 21.29 | 15.49 | 2.85 | 2.67 | | 7.86 | | | | |
| AL, KY, LA, MS, & TN Only | | | | | | | | | | | | | | | | |
| | 2-Wire Voice Grade Port (Centrex) | | | UEP91 | UEPQA | 1.15 | 21.29 | 15.49 | 2.85 | 2.67 | | 7.86 | | | | |
| | 2-Wire Voice Grade Port (Centrex 800 termination) | | | UEP91 | UEPQB | 1.15 | 21.29 | 15.49 | 2.85 | 2.67 | | 7.86 | | | | |
| | 2-Wire Voice Grade Port (Centrex with Caller ID)1 | | | UEP91 | UEPQH | 1.15 | 21.29 | 15.49 | 2.85 | 2.67 | | 7.86 | | | | |
| | 2-Wire Voice Grade Port (Centrex from diff Serving Wire Center)2 | | | UEP91 | UEPQM | 1.15 | 21.29 | 15.49 | 2.85 | 2.67 | | 7.86 | | | | |
| | 2-Wire Voice Grade Port, Diff Serving Wire Center - 800 Service Term | | | UEP91 | UEPQZ | 1.15 | 21.29 | 15.49 | 2.85 | 2.67 | | 7.86 | | | | |
| | 2-Wire Voice Grade Port terminated in on Megalink or equivalent | | | UEP91 | UEPQ9 | 1.15 | 21.29 | 15.49 | 2.85 | 2.67 | | 7.86 | | | | |
| | 2-Wire Voice Grade Port Terminated on 800 Service Term | | | UEP91 | UEPQ2 | 1.15 | 21.29 | 15.49 | 2.85 | 2.67 | | 7.86 | | | | |
| Local Switching | | | | | | | | | | | | | | | | |
| | Centrex Intercom Funtionality, per port | | | UEP91 | URECS | 0.8873 | | | | | | 7.86 | | | | |
| Local Number Portability | | | | | | | | | | | | | | | | |
| | Local Number Portability (1 per port) | | | UEP91 | LNPC | 0.35 | | | | | | | | | | |
| Features | | | | | | | | | | | | | | | | |
| | All Standard Features Offered, per port | | | UEP91 | UEPVF | 0.00 | | | | | | 7.86 | | | | |

| UNBUNDLED NETWORK ELEMENTS - Kentucky | | | | | | | | | | | Attachment: 2 | | Exhibit: D | | |
|---------------------------------------|--|---------|------|-------|-------|-----------|--------------|-------|-------------------------|----------------------------------|--------------------------------------|--|--|---|---|
| CATEGORY | RATE ELEMENTS | Interim | Zone | BCS | USOC | RATES(\$) | | | | Svc Order Submitted Elec per LSR | Svc Order Submitted Manually per LSR | Incremental Charge - Manual Svc Order vs. Electronic-1st | Incremental Charge - Manual Svc Order vs. Electronic-Add'l | Incremental Charge - Manual Svc Order vs. Electronic-Disc 1st | Incremental Charge - Manual Svc Order vs. Electronic-Disc Add'l |
| | | | | | | Rec | Nonrecurring | | Nonrecurring Disconnect | | | | | | |
| | | | | | | First | Add'l | First | Add'l | SOMEK | SOMAN | SOMAN | SOMAN | SOMAN | SOMAN |
| | All Select Features Offered, per port | | | UEP91 | UEPVS | 0.00 | 405.66 | | | | | | | | 7.86 |
| | All Centrex Control Features Offered, per port | | | UEP91 | UEPVC | 0.00 | | | | | | | | | 7.86 |
| NARS | | | | | | | | | | | | | | | |
| | Unbundled Network Access Register - Combination | | | UEP91 | UARCX | 0.00 | 0.00 | 0.00 | | | | | | | 7.86 |
| | Unbundled Network Access Register - Indial | | | UEP91 | UAR1X | 0.00 | 0.00 | 0.00 | | | | | | | 7.86 |
| | Unbundled Network Access Register - Outdial | | | UEP91 | UAROY | 0.00 | 0.00 | 0.00 | | | | | | | 7.86 |
| | Miscellaneous Terminations | | | | | | | | | | | | | | |
| | 2-Wire Trunk Side | | | | | | | | | | | | | | |
| | Trunk Side Terminations, each | | | UEP91 | CENA6 | 10.51 | 92.18 | 15.82 | 52.16 | 5.30 | | | | | 7.86 |
| | Interoffice Channel Mileage - 2-Wire | | | | | | | | | | | | | | |
| | Interoffice Channel Facilities Termination - Voice Grade | | | UEP91 | M1GBC | 29.11 | | | | | | | | | 7.86 |
| | Interoffice Channel mileage, per mile or fraction of mile | | | UEP91 | M1GBM | 0.01 | | | | | | | | | 7.86 |
| | Feature Activations (DS0) Centrex Loops on Channelized DS1 Service | | | | | | | | | | | | | | |
| | D4 Channel Bank Feature Activations | | | | | | | | | | | | | | |
| | Feature Activation on D-4 Channel Bank Centrex Loop Slot | | | UEP91 | 1PQWS | 0.62 | | | | | | | | | 7.86 |
| | Feature Activation on D-4 Channel Bank FX line Side Loop Slot | | | UEP91 | 1PQW6 | 0.62 | | | | | | | | | 7.86 |
| | Feature Activation on D-4 Channel Bank FX Trunk Side Loop Slot | | | UEP91 | 1PQW7 | 0.62 | | | | | | | | | 7.86 |
| | Feature Activation on D-4 Channel Bank Centrex Loop Slot - Different Wire Center | | | UEP91 | 1PQWP | 0.62 | | | | | | | | | 7.86 |
| | Feature Activation on D-4 Channel Bank Private Line Loop Slot | | | UEP91 | 1PQWV | 0.62 | | | | | | | | | 7.86 |
| | Feature Activation on D-4 Channel Bank Tjje Line/Trunk Loop Slot | | | UEP91 | 1PQWQ | 0.62 | | | | | | | | | 7.86 |
| | Feature Activation on D-4 Channel Bank WATS Loop Slot | | | UEP91 | 1PQWA | 0.62 | | | | | | | | | 7.86 |
| | Non-Recurring Charges (NRC) Associated with UNE-P Centrex | | | | | | | | | | | | | | |
| | Conversion - Currently Combined Switch-As-Is with allowed changes, per port | | | UEP91 | USAC2 | | 0.102 | 0.102 | | | | | | | 7.86 |
| | Conversion of Existing Centrex Common Block | | | UEP91 | USACN | | 18.95 | 8.32 | | | | | | | |
| | New Centrex Standard Common Block | | | UEP91 | M1ACS | 0.00 | 669.80 | 78.32 | 111.05 | 13.27 | | | | | 7.86 |
| | New Centrex Customized Common Block | | | UEP91 | M1ACC | 0.00 | 669.80 | 78.32 | 111.05 | 13.27 | | | | | 7.86 |
| | Secondary Block, per Block | | | UEP91 | M2CC1 | 0.00 | 78.32 | 78.32 | 13.27 | 13.27 | | | | | 7.86 |
| | NAR Establishment Charge, Per Occasion | | | UEP91 | URECA | 0.00 | 72.75 | | | | | | | | 7.86 |
| | UNE-P CENTREX - SESS (Valid in All States) | | | | | | | | | | | | | | |
| | 2-Wire VG Loop/2-Wire Voice Grade Port (Centrex) Combo | | | | | | | | | | | | | | |
| | UNE Port/Loop Combination Rates (Non-Design) | | | | | | | | | | | | | | |
| | 2-Wire VG Loop/2-Wire Voice Grade Port (Centrex) Port Combo - Non-Design | | 1 | UEP95 | | 10.79 | | | | | | | | | |
| | 2-Wire VG Loop/2-Wire Voice Grade Port (Centrex)Port Combo - Non-Design | | 2 | UEP95 | | 15.52 | | | | | | | | | |
| | 2-Wire VG Loop/2-Wire Voice Grade Port (Centrex)Port Combo - Non-Design | | 3 | UEP95 | | 31.74 | | | | | | | | | |
| | UNE Port/Loop Combination Rates (Design) | | | | | | | | | | | | | | |
| | 2-Wire VG Loop/2-Wire Voice Grade Port (Centrex) Port Combo - Design | | 1 | UEP95 | | 13.82 | | | | | | | | | |
| | 2-Wire VG Loop/2-Wire Voice Grade Port (Centrex)Port Combo - Design | | 2 | UEP95 | | 18.60 | | | | | | | | | |
| | 2-Wire VG Loop/2-Wire Voice Grade Port (Centrex)Port Combo - Design | | 3 | UEP95 | | 34.37 | | | | | | | | | |
| | UNE Loop Rate | | | | | | | | | | | | | | |
| | 2-Wire Voice Grade Loop (SL 1) - Zone 1 | | 1 | UEP95 | UECS1 | 9.64 | | | | | | | | | 7.86 |
| | 2-Wire Voice Grade Loop (SL 1) - Zone 2 | | 2 | UEP95 | UECS1 | 14.37 | | | | | | | | | 7.86 |
| | 2-Wire Voice Grade Loop (SL 1) - Zone 3 | | 3 | UEP95 | UECS1 | 30.59 | | | | | | | | | 7.86 |
| | 2-Wire Voice Grade Loop (SL 2) - Zone 1 | | 1 | UEP95 | UECS2 | 12.67 | | | | | | | | | 7.86 |
| | 2-Wire Voice Grade Loop (SL 2) - Zone 2 | | 2 | UEP95 | UECS2 | 17.45 | | | | | | | | | 7.86 |
| | 2-Wire Voice Grade Loop (SL 2) - Zone 3 | | 3 | UEP95 | UECS2 | 33.22 | | | | | | | | | 7.86 |
| | UNE Port Rate | | | | | | | | | | | | | | |
| | All States | | | | | | | | | | | | | | |
| | 2-Wire Voice Grade Port (Centrex) Basic Local Area | | | UEP95 | UEPYA | 1.15 | 21.29 | 15.49 | 2.85 | 2.67 | | | | | 7.86 |
| | 2-Wire Voice Grade Port (Centrex 800 termination) | | | UEP95 | UEPYB | 1.15 | 21.29 | 15.49 | 2.85 | 2.67 | | | | | 7.86 |
| | 2-Wire Voice Grade Port (Centrex with Caller ID)1Basic Local Area | | | UEP95 | UEPYH | 1.15 | 21.29 | 15.49 | 2.85 | 2.67 | | | | | 7.86 |

| UNBUNDLED NETWORK ELEMENTS - Kentucky | | | | | | | | | | Attachment: 2 | | Exhibit: D | | | | |
|---------------------------------------|---|---------|------|-------|-------|-----------|--------------|-------|-------------------------|----------------------------------|--------------------------------------|--|---|---|---------------|-------|
| CATEGORY | RATE ELEMENTS | Interim | Zone | BCS | USOC | RATES(\$) | | | | Svc Order Submitted Elec per LSR | Svc Order Submitted Manually per LSR | Incremental Charge - Manual Svc Order vs. Electronic-1st | Incremental Charge - Manual Svc Order vs. Electronic-Disc 1st | Incremental Charge - Manual Svc Order vs. Electronic-Disc Add'l | | |
| | | | | | | Rec | Nonrecurring | | Nonrecurring Disconnect | | | | | | OSS Rates(\$) | |
| | | | | | | | First | Add'l | First | Add'l | SOMEc | SOMAN | SOMAN | SOMAN | SOMAN | SOMAN |
| | 2-Wire Voice Grade Port (Centrex from diff Serving Wire Center)2 Basic Local Area | | | UEP95 | UEPYM | 1.15 | 21.29 | 15.49 | 2.85 | 2.67 | | 7.86 | | | | |
| | 2-Wire Voice Grade Port, Diff Serving Wire Center - 800 Service Term - Basic Local Area | | | UEP95 | UEPYZ | 1.15 | 21.29 | 15.49 | 2.85 | 2.67 | | 7.86 | | | | |
| | 2-Wire Voice Grade Port terminated in on Megalink or equivalent - Basic Local Area | | | UEP95 | UEPY9 | 1.15 | 21.29 | 15.49 | 2.85 | 2.67 | | 7.86 | | | | |
| | 2-Wire Voice Grade Port Terminated on 800 Service Term - Basic Local Area | | | UEP95 | UEPY2 | 1.15 | 21.29 | 15.49 | 2.85 | 2.67 | | 7.86 | | | | |
| | AL, KY, LA, MS, SC, & TN Only | | | | | | | | | | | | | | | |
| | 2-Wire Voice Grade Port (Centrex) | | | UEP95 | UEPQA | 1.15 | 21.29 | 15.49 | 2.85 | 2.67 | | 7.86 | | | | |
| | 2-Wire Voice Grade Port (Centrex 800 termination) | | | UEP95 | UEPQB | 1.15 | 21.29 | 15.49 | 2.85 | 2.67 | | 7.86 | | | | |
| | 2-Wire Voice Grade Port (Centrex with Caller ID)1 | | | UEP95 | UEPQH | 1.15 | 21.29 | 15.49 | 2.85 | 2.67 | | 7.86 | | | | |
| | 2-Wire Voice Grade Port (Centrex from diff Serving Wire Center)2 | | | UEP95 | UEPQM | 1.15 | 21.29 | 15.49 | 2.85 | 2.67 | | 7.86 | | | | |
| | 2-Wire Voice Grade Port, Diff Serving Wire Center - 800 Service Term | | | UEP95 | UEPQZ | 1.15 | 21.29 | 15.49 | 2.85 | 2.67 | | 7.86 | | | | |
| | 2-Wire Voice Grade Port terminated in on Megalink or equivalent | | | UEP95 | UEPQ9 | 1.15 | 21.29 | 15.49 | 2.85 | 2.67 | | 7.86 | | | | |
| | 2-Wire Voice Grade Port Terminated on 800 Service Term | | | UEP95 | UEPQ2 | 1.15 | 21.29 | 15.49 | 2.85 | 2.67 | | 7.86 | | | | |
| | Local Switching | | | | | | | | | | | | | | | |
| | Centrex Intercom Functionality, per port | | | UEP95 | URECS | 0.8873 | | | | | | 7.86 | | | | |
| | Local Number Portability | | | | | | | | | | | | | | | |
| | Local Number Portability (1 per port) | | | UEP95 | LNPCc | 0.35 | | | | | | | | | | |
| | Features | | | | | | | | | | | | | | | |
| | All Standard Features Offered, per port | | | UEP95 | UEPVF | 0.00 | | | | | | 7.86 | | | | |
| | All Select Features Offered, per port | | | UEP95 | UEPVS | 0.00 | 405.66 | | | | | 7.86 | | | | |
| | All Centrex Control Features Offered, per port | | | UEP95 | UEPVC | 0.00 | | | | | | 7.86 | | | | |
| | NARS | | | | | | | | | | | | | | | |
| | Unbundled Network Access Register - Combination | | | UEP95 | UARCX | 0.00 | 0.00 | 0.00 | | | | 7.86 | | | | |
| | Unbundled Network Access Register - Indial | | | UEP95 | UAR1X | 0.00 | 0.00 | 0.00 | | | | 7.86 | | | | |
| | Unbundled Network Access Register - Outdial | | | UEP95 | UAROX | 0.00 | 0.00 | 0.00 | | | | 7.86 | | | | |
| | Miscellaneous Terminations | | | | | | | | | | | | | | | |
| | 2-Wire Trunk Side | | | | | | | | | | | | | | | |
| | Trunk Side Terminations, each | | | UEP95 | CEnd6 | 10.51 | 92.18 | 15.82 | 52.16 | 5.30 | | 7.86 | | | | |
| | 4-Wire Digital (1.544 Megabits) | | | | | | | | | | | | | | | |
| | DS1 Circuit Terminations, each | | | UEP95 | M1HD1 | 74.77 | 164.86 | 77.74 | 60.69 | 3.86 | | 7.86 | | | | |
| | DS0 Channels Activated, each | | | UEP95 | M1HDO | 0.00 | 15.09 | | | | | 7.86 | | | | |
| | Interoffice Channel Mileage - 2-Wire | | | | | | | | | | | | | | | |
| | Interoffice Channel Facilities Termination | | | UEP95 | MIGBC | 29.11 | | | | | | 7.86 | | | | |
| | Interoffice Channel mileage, per mile or fraction of mile | | | UEP95 | MIGBM | 0.01 | | | | | | 7.86 | | | | |
| | Feature Activations (DS0) Centrex Loops on Channelized DS1 Service | | | | | | | | | | | | | | | |
| | D4 Channel Bank Feature Activations | | | | | | | | | | | | | | | |
| | Feature Activation on D-4 Channel Bank Centrex Loop Slot | | | UEP95 | 1PQWS | 0.62 | | | | | | 7.86 | | | | |
| | Feature Activation on D-4 Channel Bank FX line Side Loop Slot | | | UEP95 | 1PQW6 | 0.62 | | | | | | 7.86 | | | | |
| | Feature Activation on D-4 Channel Bank FX Trunk Side Loop Slot | | | UEP95 | 1PQW7 | 0.62 | | | | | | 7.86 | | | | |
| | Feature Activation on D-4 Channel Bank Centrex Loop Slot - Different Wire Center | | | UEP95 | 1PQWP | 0.62 | | | | | | 7.86 | | | | |
| | Feature Activation on D-4 Channel Bank Private Line Loop Slot | | | UEP95 | 1PQWV | 0.62 | | | | | | 7.86 | | | | |
| | Feature Activation on D-4 Channel Bank Tije Line/Trunk Loop Slot | | | UEP95 | 1PQWQ | 0.62 | | | | | | 7.86 | | | | |
| | Feature Activation on D-4 Channel Bank WATS Loop Slot | | | UEP95 | 1PQWA | 0.62 | | | | | | 7.86 | | | | |
| | Non-Recurring Charges (NRC) Associated with UNE-P Centrex | | | | | | | | | | | | | | | |
| | NRC Conversion Currently Combined Switch-As-Is with allowed changes, per port | | | UEP95 | USAC2 | | 0.102 | 0.102 | | | | 7.86 | | | | |
| | Conversion of Existing Centrex Common Block, each | | | UEP95 | USACN | | 18.95 | 8.32 | | | | 7.86 | | | | |
| | New Centrex Standard Common Block | | | UEP95 | M1ACS | 0.00 | 669.80 | 78.32 | 111.05 | 13.27 | | 7.86 | | | | |
| | New Centrex Customized Common Block | | | UEP95 | M1ACC | 0.00 | 669.80 | 78.32 | 111.05 | 13.27 | | 7.86 | | | | |
| | NAR Establishment Charge, Per Occasion | | | UEP95 | URECA | 0.00 | 72.75 | | | | | 7.86 | | | | |
| | UNE-P CENTREX - DMS100 (Valid in All States) | | | | | | | | | | | | | | | |
| | 2-Wire VG Loop/2-Wire Voice Grade Port (Centrex) Combo | | | | | | | | | | | | | | | |
| | UNE Port/Loop Combination Rates (Non-Design) | | | | | | | | | | | | | | | |

| UNBUNDLED NETWORK ELEMENTS - Kentucky | | | | | | | | | | | Attachment: 2 | | Exhibit: D | |
|---|--|---------|------|-------|-------|-----------|----------------------------------|--------------------------------------|--|---|---|---------------|------------|--|
| CATEGORY | RATE ELEMENTS | Interim | Zone | BCS | USOC | RATES(\$) | Svc Order Submitted Elec per LSR | Svc Order Submitted Manually per LSR | Incremental Charge - Manual Svc Order vs. Electronic-1st | Incremental Charge - Manual Svc Order vs. Electronic-Disc 1st | Incremental Charge - Manual Svc Order vs. Electronic-Disc Add'l | OSS Rates(\$) | | |
| | | | | | | | | | | | | SOMEc | SOMAN | |
| | | | | | | Rec | Nonrecurring | | Nonrecurring Disconnect | | | | | |
| | | | | | | | First | Add'l | First | Add'l | | | | |
| | 2-Wire VG Loop/2-Wire Voice Grade Port (Centrex) Port Combo - Non-Design | | 1 | UEP9D | | 10.79 | | | | | | | | |
| | 2-Wire VG Loop/2-Wire Voice Grade Port (Centrex)Port Combo - Non-Design | | 2 | UEP9D | | 15.52 | | | | | | | | |
| | 2-Wire VG Loop/2-Wire Voice Grade Port (Centrex)Port Combo - Non-Design | | 3 | UEP9D | | 31.74 | | | | | | | | |
| UNE Port/Loop Combination Rates (Design) | | | | | | | | | | | | | | |
| | 2-Wire VG Loop/2-Wire Voice Grade Port (Centrex) Port Combo - Design | | 1 | UEP9D | | 13.82 | | | | | | | | |
| | 2-Wire VG Loop/2-Wire Voice Grade Port (Centrex)Port Combo - Design | | 2 | UEP9D | | 18.60 | | | | | | | | |
| | 2-Wire VG Loop/2-Wire Voice Grade Port (Centrex)Port Combo - Design | | 3 | UEP9D | | 34.37 | | | | | | | | |
| UNE Loop Rate | | | | | | | | | | | | | | |
| | 2-Wire Voice Grade Loop (SL 1) - Zone 1 | | 1 | UEP9D | UECS1 | 9.64 | | | | | 7.86 | | | |
| | 2-Wire Voice Grade Loop (SL 1) - Zone 2 | | 2 | UEP9D | UECS1 | 14.37 | | | | | 7.86 | | | |
| | 2-Wire Voice Grade Loop (SL 1) - Zone 3 | | 3 | UEP9D | UECS1 | 30.59 | | | | | 7.86 | | | |
| | 2-Wire Voice Grade Loop (SL 2) - Zone 1 | | 1 | UEP9D | UECS2 | 12.67 | | | | | 7.86 | | | |
| | 2-Wire Voice Grade Loop (SL 2) - Zone 2 | | 2 | UEP9D | UECS2 | 17.45 | | | | | 7.86 | | | |
| | 2-Wire Voice Grade Loop (SL 2) - Zone 3 | | 3 | UEP9D | UECS2 | 33.22 | | | | | 7.86 | | | |
| UNE Port Rate | | | | | | | | | | | | | | |
| ALL STATES | | | | | | | | | | | | | | |
| | 2-Wire Voice Grade Port (Centrex) Basic Local Area | | | UEP9D | UEPYA | 1.15 | 21.29 | 15.49 | 2.85 | 2.67 | | 7.86 | | |
| | 2-Wire Voice Grade Port (Centrex 800 termination)Basic Local Area | | | UEP9D | UEPYB | 1.15 | 21.29 | 15.49 | 2.85 | 2.67 | | 7.86 | | |
| | 2-Wire Voice Grade Port (Centrex / EBS-PSET)3Basic Local Area | | | UEP9D | UEPYC | 1.15 | 21.29 | 15.49 | 2.85 | 2.67 | | 7.86 | | |
| | 2-Wire Voice Grade Port (Centrex / EBS-M5009)3Basic Local Area | | | UEP9D | UEPYD | 1.15 | 21.29 | 15.49 | 2.85 | 2.67 | | 7.86 | | |
| | 2-Wire Voice Grade Port (Centrex / EBS-M5209)3 Basic Local Area | | | UEP9D | UEPYE | 1.15 | 21.29 | 15.49 | 2.85 | 2.67 | | 7.86 | | |
| | 2-Wire Voice Grade Port (Centrex / EBS-M5112)3 Basic Local Area | | | UEP9D | UEPYF | 1.15 | 21.29 | 15.49 | 2.85 | 2.67 | | 7.86 | | |
| | 2-Wire Voice Grade Port (Centrex / EBS-M5312)3Basic Local Area | | | UEP9D | UEPYG | 1.15 | 21.29 | 15.49 | 2.85 | 2.67 | | 7.86 | | |
| | 2-Wire Voice Grade Port (Centrex / EBS-M5008)3 Basic Local Area | | | UEP9D | UEPYT | 1.15 | 21.29 | 15.49 | 2.85 | 2.67 | | 7.86 | | |
| | 2-Wire Voice Grade Port (Centrex / EBS-M5216)3 Basic Local Area | | | UEP9D | UEPYU | 1.15 | 21.29 | 15.49 | 2.85 | 2.67 | | 7.86 | | |
| | 2-Wire Voice Grade Port (Centrex / EBS-M5316)3 Basic Local Area | | | UEP9D | UEPYV | 1.15 | 21.29 | 15.49 | 2.85 | 2.67 | | 7.86 | | |
| | 2-Wire Voice Grade Port (Centrex / EBS-M5316)3 Basic Local Area | | | UEP9D | UEPY3 | 1.15 | 21.29 | 15.49 | 2.85 | 2.67 | | 7.86 | | |
| | 2-Wire Voice Grade Port (Centrex with Caller ID) Basic Local Area | | | UEP9D | UEPYH | 1.15 | 21.29 | 15.49 | 2.85 | 2.67 | | 7.86 | | |
| | 2-Wire Voice Grade Port (Centrex/Caller ID/Msg Wtg Lamp Indication))3 Basic Local Area | | | UEP9D | UEPYW | 1.15 | 21.29 | 15.49 | 2.85 | 2.67 | | 7.86 | | |
| | 2-Wire Voice Grade Port (Centrex/Msg Wtg Lamp Indication))3 Basic Local Area | | | UEP9D | UEPYJ | 1.15 | 21.29 | 15.49 | 2.85 | 2.67 | | 7.86 | | |
| | 2-Wire Voice Grade Port (Centrex from diff Serving Wire Center) 2 Basic Local Area | | | UEP9D | UEPYM | 1.15 | 21.29 | 15.49 | 2.85 | 2.67 | | 7.86 | | |
| | 2-Wire Voice Grade Port (Centrex/differ SWC /EBS-PSET)2, 3 Basic Local Area | | | UEP9D | UEPYO | 1.15 | 21.29 | 15.49 | 2.85 | 2.67 | | 7.86 | | |
| | 2-Wire Voice Grade Port (Centrex/differ SWC /EBS-M5009)2, 3 Basic Local Area | | | UEP9D | UEPYP | 1.15 | 21.29 | 15.49 | 2.85 | 2.67 | | 7.86 | | |
| | 2-Wire Voice Grade Port (Centrex/differ SWC /EBS-5209)2, 3 Basic Local Area | | | UEP9D | UEPYQ | 1.15 | 21.29 | 15.49 | 2.85 | 2.67 | | 7.86 | | |
| | 2-Wire Voice Grade Port (Centrex/differ SWC /EBS-M5112)2, 3 Basic Local Area | | | UEP9D | UEPYR | 1.15 | 21.29 | 15.49 | 2.85 | 2.67 | | 7.86 | | |
| | 2-Wire Voice Grade Port (Centrex/differ SWC /EBS-M5312)2, 3 Basic Local Area | | | UEP9D | UEPYS | 1.15 | 21.29 | 15.49 | 2.85 | 2.67 | | 7.86 | | |
| | 2-Wire Voice Grade Port (Centrex/differ SWC /EBS-M5008)2, 3 Basic Local Area | | | UEP9D | UEPY4 | 1.15 | 21.29 | 15.49 | 2.85 | 2.67 | | 7.86 | | |

| UNBUNDLED NETWORK ELEMENTS - Kentucky | | | | | | | | | | Attachment: 2 | | Exhibit: D | | | | |
|---|---|---------|------|-------|-------|-----------|--------------|-------|-------------------------|----------------------------------|--------------------------------------|--|--|---|---|---------------|
| CATEGORY | RATE ELEMENTS | Interim | Zone | BCS | USOC | RATES(\$) | | | | Svc Order Submitted Elec per LSR | Svc Order Submitted Manually per LSR | Incremental Charge - Manual Svc Order vs. Electronic-1st | Incremental Charge - Manual Svc Order vs. Electronic-Add'l | Incremental Charge - Manual Svc Order vs. Electronic-Disc 1st | Incremental Charge - Manual Svc Order vs. Electronic-Disc Add'l | |
| | | | | | | Rec | Nonrecurring | | Nonrecurring Disconnect | | | | | | | OSS Rates(\$) |
| | | | | | | | First | Add'l | First | Add'l | SOMEc | SOMAN | SOMAN | SOMAN | SOMAN | SOMAN |
| 2-Wire Trunk Side | | | | | | | | | | | | | | | | |
| | Trunk Side Terminations, each | | | UEP9D | CEND6 | 10.51 | 92.18 | 15.82 | 52.16 | 5.30 | | 7.86 | | | | |
| 4-Wire Digital (1.544 Megabits) | | | | | | | | | | | | | | | | |
| | DS1 Circuit Terminations, each | | | UEP9D | M1HD1 | 74.77 | 164.86 | 77.74 | 60.69 | 3.86 | | 7.86 | | | | |
| | DS0 Channels Activated per Channel | | | UEP9D | M1HDO | 0.00 | 15.09 | | | | | 7.86 | | | | |
| Interoffice Channel Mileage - 2-Wire | | | | | | | | | | | | | | | | |
| | Interoffice Channel Facilities Termination | | | UEP9D | MIGBC | 29.11 | | | | | | 7.86 | | | | |
| | Interoffice Channel mileage, per mile or fraction of mile | | | UEP9D | MIGBM | 0.01 | | | | | | 7.86 | | | | |
| Feature Activations (DS0) Centrex Loops on Channelized DS1 Service | | | | | | | | | | | | | | | | |
| D4 Channel Bank Feature Activations | | | | | | | | | | | | | | | | |
| | Feature Activation on D-4 Channel Bank Centrex Loop Slot | | | UEP9D | 1PQWS | 0.62 | | | | | | 7.86 | | | | |
| | Feature Activation on D-4 Channel Bank FX line Side Loop Slot | | | UEP9D | 1PQW6 | 0.62 | | | | | | 7.86 | | | | |
| | Feature Activation on D-4 Channel Bank FX Trunk Side Loop Slot | | | UEP9D | 1PQW7 | 0.62 | | | | | | 7.86 | | | | |
| | Feature Activation on D-4 Channel Bank Centrex Loop Slot - Different Wire Center | | | UEP9D | 1PQWP | 0.62 | | | | | | 7.86 | | | | |
| | Feature Activation on D-4 Channel Bank Private Line Loop Slot | | | UEP9D | 1PQWV | 0.62 | | | | | | 7.86 | | | | |
| | Feature Activation on D-4 Channel Bank Tjje Line/Trunk Loop Slot | | | UEP9D | 1PQWQ | 0.62 | | | | | | 7.86 | | | | |
| | Feature Activation on D-4 Channel Bank WATS Loop Slot | | | UEP9D | 1PQWA | 0.62 | | | | | | 7.86 | | | | |
| Non-Recurring Charges (NRC) Associated with UNE-P Centrex | | | | | | | | | | | | | | | | |
| | NRC Conversion Currently Combined Switch-As-Is with allowed changes, per port | | | UEP9D | USAC2 | | 0.102 | 0.102 | | | | 7.86 | | | | |
| | Conversion of existing Centrex Common Block, each | | | UEP9D | USACN | | 18.95 | 8.32 | | | | 7.86 | | | | |
| | New Centrex Standard Common Block | | | UEP9D | M1ACS | 0.00 | 669.80 | 78.32 | 111.05 | 13.27 | | 7.86 | | | | |
| | New Centrex Customized Common Block | | | UEP9D | M1ACC | 0.00 | 669.80 | 78.32 | 111.05 | 13.27 | | 7.86 | | | | |
| | NAR Establishment Charge, Per Occasion | | | UEP9D | URECA | 0.00 | 72.75 | | | | | 7.86 | | | | |
| UNE-P CENTREX - EWSD (Valid in AL, FL, KY, LA, MS & TN) | | | | | | | | | | | | | | | | |
| 2-Wire VG Loop/2-Wire Voice Grade Port (Centrex) Combo | | | | | | | | | | | | | | | | |
| UNE Port/Loop Combination Rates (Non-Design) | | | | | | | | | | | | | | | | |
| | 2-Wire VG Loop/2-Wire Voice Grade Port (Centrex) Port Combo - Non-Design | | 1 | UEP9E | | 10.79 | | | | | | | | | | |
| | 2-Wire VG Loop/2-Wire Voice Grade Port (Centrex)Port Combo - Non-Design | | 2 | UEP9E | | 15.52 | | | | | | | | | | |
| | 2-Wire VG Loop/2-Wire Voice Grade Port (Centrex)Port Combo - Non-Design | | 3 | UEP9E | | 31.74 | | | | | | | | | | |
| UNE Port/Loop Combination Rates (Design) | | | | | | | | | | | | | | | | |
| | 2-Wire VG Loop/2-Wire Voice Grade Port (Centrex) Port Combo - Design | | 1 | UEP9E | | 13.82 | | | | | | | | | | |
| | 2-Wire VG Loop/2-Wire Voice Grade Port (Centrex)Port Combo - Design | | 2 | UEP9E | | 18.60 | | | | | | | | | | |
| | 2-Wire VG Loop/2-Wire Voice Grade Port (Centrex)Port Combo - Design | | 3 | UEP9E | | 34.37 | | | | | | | | | | |
| UNE Loop Rate | | | | | | | | | | | | | | | | |
| | 2-Wire Voice Grade Loop (SL 1) - Zone 1 | | 1 | UEP9E | UECS1 | 9.64 | | | | | | 7.86 | | | | |
| | 2-Wire Voice Grade Loop (SL 1) - Zone 2 | | 2 | UEP9E | UECS1 | 14.37 | | | | | | 7.86 | | | | |
| | 2-Wire Voice Grade Loop (SL 1) - Zone 3 | | 3 | UEP9E | UECS1 | 30.59 | | | | | | 7.86 | | | | |
| | 2-Wire Voice Grade Loop (SL 2) - Zone 1 | | 1 | UEP9E | UECS2 | 12.67 | | | | | | 7.86 | | | | |
| | 2-Wire Voice Grade Loop (SL 2) - Zone 2 | | 2 | UEP9E | UECS2 | 17.45 | | | | | | 7.86 | | | | |
| | 2-Wire Voice Grade Loop (SL 2) - Zone 3 | | 3 | UEP9E | UECS2 | 33.22 | | | | | | 7.86 | | | | |
| UNE Port Rate | | | | | | | | | | | | | | | | |
| AL, FL, KY, LA, MS, & TN only | | | | | | | | | | | | | | | | |
| | 2-Wire Voice Grade Port (Centrex) Basic Local Area | | | UEP9E | UEPYA | 1.15 | 21.29 | 15.49 | 2.85 | 2.67 | | 7.86 | | | | |
| | 2-Wire Voice Grade Port (Centrex 800 termination)Basic Local Area | | | UEP9E | UEPYB | 1.15 | 21.29 | 15.49 | 2.85 | 2.67 | | 7.86 | | | | |
| | 2-Wire Voice Grade Port (Centrex with Caller ID)1Basic Local Area | | | UEP9E | UEPYH | 1.15 | 21.29 | 15.49 | 2.85 | 2.67 | | 7.86 | | | | |
| | 2-Wire Voice Grade Port (Centrex from diff Serving Wire Center)2 Basic Local Area | | | UEP9E | UEPYM | 1.15 | 21.29 | 15.49 | 2.85 | 2.67 | | 7.86 | | | | |
| | 2-Wire Voice Grade Port, Diff Serving Wire Center - 800 Service Term - Basic Local Area | | | UEP9E | UEPYZ | 1.15 | 21.29 | 15.49 | 2.85 | 2.67 | | 7.86 | | | | |

| UNBUNDLED NETWORK ELEMENTS - Kentucky | | | | | | | | | | | Attachment: 2 | | Exhibit: D | | | |
|---------------------------------------|--|---------|------|-------|-------|-----------|--------------|-------|-------------------------|----------------------------------|--------------------------------------|--|--|---|---|---------------|
| CATEGORY | RATE ELEMENTS | Interim | Zone | BCS | USOC | RATES(\$) | | | | Svc Order Submitted Elec per LSR | Svc Order Submitted Manually per LSR | Incremental Charge - Manual Svc Order vs. Electronic-1st | Incremental Charge - Manual Svc Order vs. Electronic-Add'l | Incremental Charge - Manual Svc Order vs. Electronic-Disc 1st | Incremental Charge - Manual Svc Order vs. Electronic-Disc Add'l | |
| | | | | | | Rec | Nonrecurring | | Nonrecurring Disconnect | | | | | | | OSS Rates(\$) |
| | | | | | | | First | Add'l | First | Add'l | SOMEc | SOMAN | SOMAN | SOMAN | SOMAN | SOMAN |
| | 2-Wire Voice Grade Port terminated in on Megalink or equivalent - Basic Local Area | | | UEP9E | UEPY9 | 1.15 | 21.29 | 15.49 | 2.85 | 2.67 | | 7.86 | | | | |
| | 2-Wire Voice Grade Port Terminated on 800 Service Term - Basic Local Area | | | UEP9E | UEPY2 | 1.15 | 21.29 | 15.49 | 2.85 | 2.67 | | 7.86 | | | | |
| | AL, KY, LA, MS, & TN Only | | | | | | | | | | | | | | | |
| | 2-Wire Voice Grade Port (Centrex) | | | UEP9E | UEPQA | 1.15 | 21.29 | 15.49 | 2.85 | 2.67 | | 7.86 | | | | |
| | 2-Wire Voice Grade Port (Centrex 800 termination) | | | UEP9E | UEPQB | 1.15 | 21.29 | 15.49 | 2.85 | 2.67 | | 7.86 | | | | |
| | 2-Wire Voice Grade Port (Centrex with Caller ID)1 | | | UEP9E | UEPQH | 1.15 | 21.29 | 15.49 | 2.85 | 2.67 | | 7.86 | | | | |
| | 2-Wire Voice Grade Port (Centrex from diff Serving Wire Center)2 | | | UEP9E | UEPQM | 1.15 | 21.29 | 15.49 | 2.85 | 2.67 | | 7.86 | | | | |
| | 2-Wire Voice Grade Port, Diff Serving Wire Center - 800 Service Term | | | UEP9E | UEPQZ | 1.15 | 21.29 | 15.49 | 2.85 | 2.67 | | 7.86 | | | | |
| | 2-Wire Voice Grade Port terminated in on Megalink or equivalent | | | UEP9E | UEPQ9 | 1.15 | 21.29 | 15.49 | 2.85 | 2.67 | | 7.86 | | | | |
| | 2-Wire Voice Grade Port Terminated on 800 Service Term | | | UEP9E | UEPQ2 | 1.15 | 21.29 | 15.49 | 2.85 | 2.67 | | 7.86 | | | | |
| | Local Switching | | | | | | | | | | | | | | | |
| | Centrex Intercom Functionality, per port | | | UEP9E | URECS | 0.8873 | | | | | | 7.86 | | | | |
| | Local Number Portability | | | | | | | | | | | | | | | |
| | Local Number Portability (1 per port) | | | UEP9E | LNPCc | 0.35 | | | | | | 7.86 | | | | |
| | Features | | | | | | | | | | | | | | | |
| | All Standard Features Offered, per port | | | UEP9E | UEPVF | 0.00 | | | | | | 7.86 | | | | |
| | All Select Features Offered, per port | | | UEP9E | UEPVS | 0.00 | 405.66 | | | | | 7.86 | | | | |
| | All Centrex Control Features Offered, per port | | | UEP9E | UEPVC | 0.00 | | | | | | 7.86 | | | | |
| | NARS | | | | | | | | | | | | | | | |
| | Unbundled Network Access Register - Combination | | | UEP9E | UARCX | 0.00 | 0.00 | 0.00 | | | | | | | | |
| | Unbundled Network Access Register - Indial | | | UEP9E | UAR1X | 0.00 | 0.00 | 0.00 | | | | | | | | |
| | Unbundled Network Access Register - Outdial | | | UEP9E | UAROx | 0.00 | 0.00 | 0.00 | | | | | | | | |
| | Miscellaneous Terminations | | | | | | | | | | | | | | | |
| | 2-Wire Trunk Side | | | | | | | | | | | | | | | |
| | Trunk Side Terminations, each | | | UEP9E | CEND6 | 10.51 | 92.18 | 15.82 | 52.16 | 5.30 | | 7.86 | | | | |
| | 4-Wire Digital (1.544 Megabits) | | | | | | | | | | | | | | | |
| | DS1 Circuit Terminations, each | | | UEP9E | M1HD1 | 74.77 | 164.86 | 77.74 | 60.69 | 3.86 | | 7.86 | | | | |
| | DS0 Channel Activated Per Channel | | | UEP9E | M1HDO | 0.00 | 15.09 | | | | | 7.86 | | | | |
| | Interoffice Channel Mileage - 2-Wire | | | | | | | | | | | | | | | |
| | Interoffice Channel Facilities Termination | | | UEP9E | MIGBC | 29.11 | | | | | | 7.86 | | | | |
| | Interoffice Channel mileage, per mile or fraction of mile | | | UEP9E | MIGBM | 0.01 | | | | | | 7.86 | | | | |
| | Feature Activations (DS0) Centrex Loops on Channelized DS1 Service | | | | | | | | | | | | | | | |
| | D4 Channel Bank Feature Activations | | | | | | | | | | | | | | | |
| | Feature Activation on D-4 Channel Bank Centrex Loop Slot | | | UEP9E | 1PQWS | 0.62 | | | | | | 7.86 | | | | |
| | Feature Activation on D-4 Channel Bank FX line Side Loop Slot | | | UEP9E | 1PQW6 | 0.62 | | | | | | 7.86 | | | | |
| | Feature Activation on D-4 Channel Bank FX Trunk Side Loop Slot | | | UEP9E | 1PQW7 | 0.62 | | | | | | 7.86 | | | | |
| | Feature Activation on D-4 Channel Bank Centrex Loop Slot - Different Wire Center | | | UEP9E | 1PQWP | 0.62 | | | | | | 7.86 | | | | |
| | Feature Activation on D-4 Channel Bank Private Line Loop Slot | | | UEP9E | 1PQWV | 0.62 | | | | | | 7.86 | | | | |
| | Feature Activation on D-4 Channel Bank Tjje Line/Trunk Loop Slot | | | UEP9E | 1PQWQ | 0.62 | | | | | | 7.86 | | | | |
| | Feature Activation on D-4 Channel Bank WATS Loop Slot | | | UEP9E | 1PQWA | 0.62 | | | | | | 7.86 | | | | |
| | Non-Recurring Charges (NRC) Associated with UNE-P Centrex | | | | | | | | | | | | | | | |
| | NRC Conversion Currently Combined Switch-As-Is with allowed changes, per port | | | UEP9E | USAC2 | | 0.102 | 0.102 | | | | 7.86 | | | | |
| | Conversion of Existing Centrex Common Block, each | | | UEP9E | USACN | | 18.95 | 8.32 | | | | | | | | |
| | New Centrex Standard Common Block | | | UEP9E | M1ACS | 0.00 | 669.80 | 78.32 | 111.05 | 13.27 | | 7.86 | | | | |
| | New Centrex Customized Common Block | | | UEP9E | M1ACC | 0.00 | 669.80 | 78.32 | 111.05 | 13.27 | | 7.86 | | | | |
| | NAR Establishment Charge, Per Occasion | | | UEP9E | URECA | 0.00 | 72.75 | | | | | 7.86 | | | | |
| | UNE-P CENTREX - DCO - Valid in AL, KY, LA, MS, & TN) | | | | | | | | | | | | | | | |
| | 2-Wire VG Loop/2-Wire Voice Grade Port (Centrex) Combo | | | | | | | | | | | | | | | |
| | UNE Port/Loop Combination Rates (Non-Design) | | | | | | | | | | | | | | | |
| | 2-Wire VG Loop/2-Wire Voice Grade Port (Centrex) Port Combo - Non-Design | | 1 | UEP93 | | 10.79 | | | | | | | | | | |
| | 2-Wire VG Loop/2-Wire Voice Grade Port (Centrex)Port Combo - Non-Design | | 2 | UEP93 | | 15.52 | | | | | | | | | | |

| UNBUNDLED NETWORK ELEMENTS - Kentucky | | | | | | | | | | | Attachment: 2 | | Exhibit: D | | | |
|---------------------------------------|---|---------|------|-------|-------|-----------|----------------------------------|--------------------------------------|--|--|---|---|------------|--------------|-------|-------------------------|
| CATEGORY | RATE ELEMENTS | Interim | Zone | BCS | USOC | RATES(\$) | Svc Order Submitted Elec per LSR | Svc Order Submitted Manually per LSR | Incremental Charge - Manual Svc Order vs. Electronic-1st | Incremental Charge - Manual Svc Order vs. Electronic-Add'l | Incremental Charge - Manual Svc Order vs. Electronic-Disc 1st | Incremental Charge - Manual Svc Order vs. Electronic-Disc Add'l | | | | |
| | | | | | | | | | | | | | Rec | Nonrecurring | | Nonrecurring Disconnect |
| | | | | | | | First | Add'l | First | Add'l | SOMEC | SOMAN | SOMAN | SOMAN | SOMAN | SOMAN |
| | 2-Wire VG Loop/2-Wire Voice Grade Port (Centrex)Port Combo - Non-Design | | 3 | UEP93 | | 31.74 | | | | | | | | | | |
| | UNE Port/Loop Combination Rates (Design) | | | | | | | | | | | | | | | |
| | 2-Wire VG Loop/2-Wire Voice Grade Port (Centrex) Port Combo - Design | | 1 | UEP93 | | 13.82 | | | | | | | | | | |
| | 2-Wire VG Loop/2-Wire Voice Grade Port (Centrex)Port Combo - Design | | 2 | UEP93 | | 18.60 | | | | | | | | | | |
| | 2-Wire VG Loop/2-Wire Voice Grade Port (Centrex)Port Combo - Design | | 3 | UEP93 | | 34.37 | | | | | | | | | | |
| | UNE Loop Rate | | | | | | | | | | | | | | | |
| | 2-Wire Voice Grade Loop (SL 1) - Zone 1 | | 1 | UEP93 | UECS1 | 9.64 | | | | | | | | | | |
| | 2-Wire Voice Grade Loop (SL 1) - Zone 2 | | 2 | UEP93 | UECS1 | 14.37 | | | | | | | | | | |
| | 2-Wire Voice Grade Loop (SL 1) - Zone 3 | | 3 | UEP93 | UECS1 | 30.59 | | | | | | | | | | |
| | 2-Wire Voice Grade Loop (SL 2) - Zone 1 | | 1 | UEP93 | UECS2 | 12.67 | | | | | | | | | | |
| | 2-Wire Voice Grade Loop (SL 2) - Zone 2 | | 2 | UEP93 | UECS2 | 17.45 | | | | | | | | | | |
| | 2-Wire Voice Grade Loop (SL 2) - Zone 3 | | 3 | UEP93 | UECS2 | 33.22 | | | | | | | | | | |
| | UNE Port Rate | | | | | | | | | | | | | | | |
| | AL, KY, LA, MS, & TN only | | | | | | | | | | | | | | | |
| | 2-Wire Voice Grade Port (Centrex) Basic Local Area | | | UEP93 | UEPYA | 1.15 | 21.29 | 15.49 | 2.85 | 2.67 | | 7.86 | | | | |
| | 2-Wire Voice Grade Port (Centrex 800 termination)Basic Local Area | | | UEP93 | UEPYB | 1.15 | 21.29 | 15.49 | 2.85 | 2.67 | | 7.86 | | | | |
| | 2-Wire Voice Grade Port (Centrex with Caller ID)1Basic Local Area | | | UEP93 | UEPYH | 1.15 | 21.29 | 15.49 | 2.85 | 2.67 | | 7.86 | | | | |
| | 2-Wire Voice Grade Port (Centrex from diff Serving Wire Center)2 Basic Local Area | | | UEP93 | UEPYM | 1.15 | 21.29 | 15.49 | 2.85 | 2.67 | | 7.86 | | | | |
| | 2-Wire Voice Grade Port, Diff Serving Wire Center - 800 Service Term - Basic Local Area | | | UEP93 | UEPYZ | 1.15 | 21.29 | 15.49 | 2.85 | 2.67 | | 7.86 | | | | |
| | 2-Wire Voice Grade Port terminated in on Megalink or equivalent - Basic Local Area | | | UEP93 | UEPY9 | 1.15 | 21.29 | 15.49 | 2.85 | 2.67 | | 7.86 | | | | |
| | 2-Wire Voice Grade Port Terminated on 800 Service Term - Basic Local Area | | | UEP93 | UEPY2 | 1.15 | 21.29 | 15.49 | 2.85 | 2.67 | | 7.86 | | | | |
| | 2-Wire Voice Grade Port (Centrex) | | | UEP93 | UEPQA | 1.15 | 21.29 | 15.49 | 2.85 | 2.67 | | 7.86 | | | | |
| | 2-Wire Voice Grade Port (Centrex 800 termination) | | | UEP93 | UEPQB | 1.15 | 21.29 | 15.49 | 2.85 | 2.67 | | 7.86 | | | | |
| | 2-Wire Voice Grade Port (Centrex with Caller ID)1 | | | UEP93 | UEPQH | 1.15 | 21.29 | 15.49 | 2.85 | 2.67 | | 7.86 | | | | |
| | 2-Wire Voice Grade Port (Centrex from diff Serving Wire Center)2 | | | UEP93 | UEPQM | 1.15 | 21.29 | 15.49 | 2.85 | 2.67 | | 7.86 | | | | |
| | 2-Wire Voice Grade Port, Diff Serving Wire Center - 800 Service Term | | | UEP93 | UEPQZ | 1.15 | 21.29 | 15.49 | 2.85 | 2.67 | | 7.86 | | | | |
| | 2-Wire Voice Grade Port terminated in on Megalink or equivalent | | | UEP93 | UEPQ9 | 1.15 | 21.29 | 15.49 | 2.85 | 2.67 | | 7.86 | | | | |
| | 2-Wire Voice Grade Port Terminated on 800 Service Term | | | UEP93 | UEPQ2 | 1.15 | 21.29 | 15.49 | 2.85 | 2.67 | | 7.86 | | | | |
| | Local Switching | | | | | | | | | | | | | | | |
| | Centrex Intercom Functionality, per port | | | UEP93 | URECS | 0.8873 | | | | | | 7.86 | | | | |
| | Local Number Portability | | | | | | | | | | | | | | | |
| | Local Number Portability (1 per port) | | | UEP93 | LNCCC | 0.35 | | | | | | | | | | |
| | Features | | | | | | | | | | | | | | | |
| | All Standard Features Offered, per port | | | UEP93 | UEPVF | 0.00 | | | | | | 7.86 | | | | |
| | All Centrex Control Features Offered, per port | | | UEP93 | UEPVC | 0.00 | | | | | | 7.86 | | | | |
| | NARS | | | | | | | | | | | | | | | |
| | Unbundled Network Access Register - Combination | | | UEP93 | UARCX | 0.00 | 0.00 | 0.00 | | | | | | | | |
| | Unbundled Network Access Register - Indial | | | UEP93 | UAR1X | 0.00 | 0.00 | 0.00 | | | | | | | | |
| | Unbundled Network Access Register - Outdial | | | UEP93 | UAROX | 0.00 | 0.00 | 0.00 | | | | | | | | |
| | Miscellaneous Terminations | | | | | | | | | | | | | | | |
| | 2-Wire Trunk Side | | | | | | | | | | | | | | | |
| | Trunk Side Terminations, each | | | UEP93 | CEND6 | 10.51 | 92.18 | 15.82 | 52.16 | 5.30 | | 7.86 | | | | |
| | 4-Wire Digital (1.544 Megabits) | | | | | | | | | | | | | | | |
| | DS1 Circuit Terminations, each | | | UEP93 | M1HD1 | 74.77 | 164.86 | 77.74 | 60.69 | 3.86 | | 7.86 | | | | |
| | DS0 Channels Activated, Per Channel | | | UEP93 | M1HDO | 0.00 | 15.09 | | | | | 7.86 | | | | |
| | Interoffice Channel Mileage - 2-Wire | | | | | | | | | | | | | | | |
| | Interoffice Channel Facilities Termination | | | UEP93 | MIGBC | 29.11 | | | | | | 7.86 | | | | |
| | Interoffice Channel mileage, per mile or fraction of mile | | | UEP93 | MIGBM | 0.01 | | | | | | 7.86 | | | | |
| | Feature Activations (DS0) Centrex Loops on Channelized DS1 Service | | | | | | | | | | | | | | | |
| | D4 Channel Bank Feature Activations | | | | | | | | | | | | | | | |
| | Feature Activation on D-4 Channel Bank Centrex Loop Slot | | | UEP93 | 1PQWS | 0.62 | | | | | | 7.86 | | | | |

| LOCAL INTERCONNECTION - Kentucky | | | | | | | Attachment: 3 | | Exhibit: A | | | | | | |
|---|---|---------|------|------------|-------|------------|----------------------------------|--------------------------------------|--|--|---|---|-------|--------------|-------|
| CATEGORY | RATE ELEMENTS | Interim | Zone | BCS | USOC | RATES (\$) | Svc Order Submitted Elec per LSR | Svc Order Submitted Manually per LSR | Incremental Charge - Manual Svc Order vs. Electronic-1st | Incremental Charge - Manual Svc Order vs. Electronic-Add'l | Incremental Charge - Manual Svc Order vs. Electronic-Disc 1st | Incremental Charge - Manual Svc Order vs. Electronic-Disc Add'l | | | |
| | | | | | | | | | | | | | Rec | Nonrecurring | |
| | | | | | | | | | | | | | | | |
| | | | | | | | | | | SOMEc | SOMAN | SOMAN | SOMAN | SOMAN | SOMAN |
| LOCAL INTERCONNECTION (CALL TRANSPORT AND TERMINATION) | | | | | | | | | | | | | | | |
| NOTE: "bk" beside a rate indicates that the Parties have agreed to bill and keep for that element pursuant to the terms and conditions in Attachment 3. | | | | | | | | | | | | | | | |
| INTERCARRIER COMPENSATION FOR LOCAL AND ISP-BOUND TRAFFIC | | | | | | | | | | | | | | | |
| | Composite Rate for Local and ISP-Bound Traffic, per MOU (Effective Date of Agreement through June 13, 2003) | | | | | 0.001 | | | | | | | | | |
| | Composite Rate for Local and ISP-Bound Traffic, per MOU (June 14, 2003 through December 31, 2003) | | | | | 0.0007 | | | | | | | | | |
| INTERCARRIER COMPENSATION FOR LOCAL TRANSIT TRAFFIC AND MTA TRAFFIC | | | | | | | | | | | | | | | |
| TANDEM SWITCHING | | | | | | | | | | | | | | | |
| | Tandem Switching Function Per MOU | | | OHD | | 0.0006772 | | | | | | | | | |
| | Multiple Tandem Switching, per MOU (applies to initial tandem only) | | | OHD | | 0.0006772 | | | | | | | | | |
| | Tandem Intermediary Charge, per MOU* | | | OHD | | 0.0015 | | | | | | | | | |
| * This charge is applicable only to transit traffic and is applied in addition to applicable switching and/or interconnection charges. | | | | | | | | | | | | | | | |
| TRUNK CHARGE | | | | | | | | | | | | | | | |
| | Installation Trunk Side Service - per DS0 | | | OHD | TPP++ | | 334.09 | 57.12 | | | | | | | |
| | Dedicated End Office Trunk Port Service-per DS0** | | | OHD | TDE0P | 0.00 | | | | | | | | | |
| | Dedicated End Office Trunk Port Service-per DS1** | | | OH1 OH1MS | TDE1P | 0.00 | | | | | | | | | |
| | Dedicated Tandem Trunk Port Service-per DS0** | | | OHD | TDW0P | 0.00 | | | | | | | | | |
| | Dedicated Tandem Trunk Port Service-per DS1** | | | OH1 OH1MS | TDW1P | 0.00 | | | | | | | | | |
| ** This rate element is recovered on a per MOU basis and is included in the End Office Switching and Tandem Switching, per MOU rate elements | | | | | | | | | | | | | | | |
| COMMON TRANSPORT (Shared) | | | | | | | | | | | | | | | |
| | Common Transport - Per Mile, Per MOU | | | OHD | | 0.000003 | | | | | | | | | |
| | Common Transport - Facilities Termination Per MOU | | | OHD | | 0.0007466 | | | | | | | | | |
| LOCAL INTERCONNECTION (DEDICATED TRANSPORT) | | | | | | | | | | | | | | | |
| INTEROFFICE CHANNEL - DEDICATED TRANSPORT | | | | | | | | | | | | | | | |
| | Interoffice Channel - Dedicated Transport - 2-Wire Voice Grade - Per Mile per month | | | OHL, OHM | 1L5NF | 0.01bk | | | | | | | | | |
| | Interoffice Channel - Dedicated Transport- 2- Wire Voice Grade - Facility Termination per month | | | OHL, OHM | 1L5NF | 29.11bk | 47.34bk | 31.78bk | 22.77bk | 8.75bk | | | | | |
| | Interoffice Channel - Dedicated Transport - 56 kbps - per mile per month | | | OHL, OHM | 1L5NK | 0.0115bk | | | | | | | | | |
| | Interoffice Channel - Dedicated Transport - 56 kbps - Facility Termination per month | | | OHL, OHM | 1L5NK | 20.97bk | 47.35bk | 31.78bk | 22.77bk | 8.75bk | | | | | |
| | Interoffice Channel - Dedicated Transport - 64 kbps - per mile per month | | | OHL, OHM | 1L5NK | 0.0115bk | | | | | | | | | |
| | Interoffice Channel - Dedicated Transport - 64 kbps - Facility Termination per month | | | OHL, OHM | 1L5NK | 20.97bk | 47.35bk | 31.78bk | 22.77bk | 8.75bk | | | | | |
| | Interoffice Channel - Dedicated Channel - DS1 - Per Mile per month | | | OH1, OH1MS | 1L5NL | 0.23bk | | | | | | | | | |
| | Interoffice Channel - Dedicated Transport - DS1 - Facility Termination per month | | | OH1, OH1MS | 1L5NL | 96.04bk | 105.52bk | 98.46bk | 23.09bk | 20.49bk | | | | | |
| | Interoffice Channel - Dedicated Transport - DS3 - Per Mile per month | | | OH3, OH3MS | 1L5NM | 4.97bk | | | | | | | | | |
| | Interoffice Channel - Dedicated Transport - DS3 - Facility Termination per month | | | OH3, OH3MS | 1L5NM | 1175.15bk | 335.4bk | 219.24bk | 89.57bk | 87.75bk | | | | | |
| LOCAL CHANNEL - DEDICATED TRANSPORT | | | | | | | | | | | | | | | |
| | Local Channel - Dedicated - 2-Wire Voice Grade per month | | | OHL, OHM | TEFV2 | 18.57bk | 265.78bk | 46.96bk | 46.79bk | 4.98bk | | | | | |
| | Local Channel - Dedicated - 4-Wire Voice Grade per month | | | OHL, OHM | TEFV4 | 19.86bk | 266.48bk | 47.65bk | 47.54bk | 5.73bk | | | | | |
| | Local Channel - Dedicated - DS1 per month | | | OH1 | TEFHG | 40.46bk | 209.6bk | 176.51bk | 30.21bk | 21.07bk | | | | | |
| | Local Channel - Dedicated - DS3 Facility Termination per month | | | OH3 | TEFHJ | 576.05bk | 551.38bk | 338.08bk | 173bk | 120.42bk | | | | | |
| LOCAL INTERCONNECTION MID-SPAN MEET | | | | | | | | | | | | | | | |
| NOTE: If Access service ride Mid-Span Meet, one-half the tariffed service Local Channel rate is applicable. | | | | | | | | | | | | | | | |
| | Local Channel - Dedicated - DS1 per month | | | OH1MS | TEFHG | 0.00 | 0.00 | | | | | | | | |
| | Local Channel - Dedicated - DS3 per month | | | OH3MS | TEFHJ | 0.00 | 0.00 | | | | | | | | |
| MULTIPLEXERS | | | | | | | | | | | | | | | |
| | Channelization - DS1 to DS0 Channel System | | | OH1, OH1MS | SATN1 | 113.33 | 101.40 | 71.60 | 13.79 | 13.04 | | | | | |
| | DS3 to DS1 Channel System per month | | | OH3, OH3MS | SATNS | 158.20 | 199.23 | 118.62 | 50.16 | 48.59 | | | | | |

| LOCAL INTERCONNECTION - Kentucky | | | | | | | | | | Attachment: 3 | | Exhibit: A | | | |
|---|---|---------|------|------------|-------|------------|--------------|-------|-------------------------|----------------------------------|--------------------------------------|--|--|---|---|
| CATEGORY | RATE ELEMENTS | Interim | Zone | BCS | USOC | RATES (\$) | | | | Svc Order Submitted Elec per LSR | Svc Order Submitted Manually per LSR | Incremental Charge - Manual Svc Order vs. Electronic-1st | Incremental Charge - Manual Svc Order vs. Electronic-Add'l | Incremental Charge - Manual Svc Order vs. Electronic-Disc 1st | Incremental Charge - Manual Svc Order vs. Electronic-Disc Add'l |
| | | | | | | Rec | Nonrecurring | | Nonrecurring Disconnect | | | | | | |
| | | | | | | | First | Add'l | First | Add'l | SOMEK | SOMAN | SOMAN | SOMAN | SOMAN |
| | DS3 Interface Unit (DS1 COCI) per month | | | OH1, OH1MS | SATCO | 11.80 | 10.07 | 7.08 | | | | | | | |
| Notes: If no rate is identified in the contract, the rates, terms, and conditions for the specific service or function will be as set forth in applicable BellSouth tariff. | | | | | | | | | | | | | | | |

| COLLOCATION - Kentucky | | | | | | | | | | Attachment: 4 | | Exhibit: B | | | |
|-----------------------------|--|---------|------|--|-------|------------|--------------|----------|-------------------------|----------------------------------|--------------------------------------|--|--|---|---|
| CATEGORY | RATE ELEMENTS | Interim | Zone | BCS | USOC | RATES (\$) | | | | Svc Order Submitted Elec per LSR | Svc Order Submitted Manually per LSR | Incremental Charge - Manual Svc Order vs. Electronic-1st | Incremental Charge - Manual Svc Order vs. Electronic-Add'l | Incremental Charge - Manual Svc Order vs. Electronic-Disc 1st | Incremental Charge - Manual Svc Order vs. Electronic-Disc Add'l |
| | | | | | | Rec | Nonrecurring | | Nonrecurring Disconnect | | | | | | |
| | | | | | | | First | Add'l | First | Add'l | SOMEK | SOMAN | SOMAN | SOMAN | SOMAN |
| PHYSICAL COLLOCATION | | | | | | | | | | | | | | | |
| | Physical Collocation - Application Fee - Initial | | | CLO | PE1BA | | 3,773.54 | 3,773.54 | 1.01 | 1.01 | | | | | |
| | Physical Collocation - Application Fee - Subsequent | | | CLO | PE1CA | | 3,145.35 | 3,145.35 | 1.01 | 1.01 | | | | | |
| | Physical Collocation Administrative Only - Application Fee | | | CLO | PE1BL | | 742.12 | | | | | | | | |
| | Physical Collocation - Space Preparation - Firm Order Processing | | | CLO | PE1SJ | | 1,206.07 | 1,206.07 | | | | | | | |
| | Physical Collocation - Space Preparation - C.O. Modification per square ft. | | | CLO | PE1SK | 2.32 | | | | | | | | | |
| | Physical Collocation - Space Preparation - Common Systems Modification per square ft. - Cageless | | | CLO | PE1SL | 3.26 | | | | | | | | | |
| | Physical Collocation - Space Preparation - Common Systems Modification per Cage | | | CLO | PE1SM | 110.57 | | | | | | | | | |
| | Physical Collocation - Cable Installation | | | CLO | PE1BD | | 1,729.11 | | 45.16 | | | | | | |
| | Physical Collocation - Floor Space per Sq. Ft. | | | CLO | PE1PJ | | 7.99 | | | | | | | | |
| | Physical Collocation - Cable Support Structure | | | CLO | PE1PM | | 19.86 | | | | | | | | |
| | Physical Collocation - Power -48V DC Power, per Fused Amp | | | CLO | PE1PL | | 8.06 | | | | | | | | |
| | Physical Collocation - Power Reduction, Application Fee | I | | CLO | PE1PR | | 399.50 | | | | | | | | |
| | Physical Collocation - 120V, Single Phase Standby Power Rate | | | CLO | PE1FB | | 5.44 | | | | | | | | |
| | Physical Collocation - 240V, Single Phase Standby Power Rate | | | CLO | PE1FD | | 10.88 | | | | | | | | |
| | Physical Collocation - 120V, Three Phase Standby Power Rate | | | CLO | PE1FE | | 16.32 | | | | | | | | |
| | Physical Collocation - 277V, Three Phase Standby Power Rate | | | CLO | PE1FG | | 37.68 | | | | | | | | |
| | Physical Collocation - 2-Wire Cross-Connects | | | UEANL,UEA,UDN,U DC,UAL,UHL,UCL,U EQ, UDL, UNCVX, UNLDX, UNCNX | PE1P2 | 0.0333 | 24.68 | 23.68 | 12.14 | 10.95 | | | | | |
| | Physical Collocation - 4-Wire Cross-Connects | | | CLO, UAL, UDL, UDN, UEA, UHL, UNCVX, UNCDX, UCL | PE1P4 | 0.0665 | 24.88 | 23.82 | 12.77 | 11.46 | | | | | |
| | Physical Collocation - DS1 Cross-Connects | | | CLO,UEANL,UEQ,W DS1L,WDS1S, USL, U1TD1, UXTD1, UNC1X, ULDD1, USLEL, UNLD1, UDL | PE1P1 | 1.48 | 44.23 | 31.98 | 12.81 | 11.57 | | | | | |
| | Physical Collocation - DS3 Cross-Connects | | | CLO, UE3,U1TD3, UXTD3, UXTS1, UNC3X, UNCSX, ULDD3, U1TS1,ULDS1, UNLD3, UDL | PE1P3 | 18.89 | 41.93 | 30.51 | 14.75 | 11.83 | | | | | |
| | Physical Collocation - 2-Fiber Cross-Connect | | | CLO, ULDO3, ULD12, ULD48, U1TO3, U1T12, U1T48, UDLO3, UDL12, UDF | PE1F2 | 3.75 | 41.93 | 30.51 | 14.76 | 11.84 | | | | | |
| | Physical Collocation - 4-Fiber Cross-Connect | | | CLO, ULDO3, ULD12, ULD48, U1TO3, U1T12, U1T48, UDLO3, UDL12, UDF | PE1F4 | 6.65 | 51.29 | 39.87 | 19.41 | 16.49 | | | | | |
| | Physical Collocation - Welded Wire Cage - First 100 Sq. Ft. | | | CLO | PE1BW | | 184.97 | | | | | | | | |
| | Physical Collocation - Welded Wire Cage - Add'l 50 Sq. Ft. | | | CLO | PE1CW | | 18.14 | | | | | | | | |

| COLLOCATION - Kentucky | | | | | | | | | | | Attachment: 4 | | Exhibit: B | | |
|------------------------|---|---------|------|--|-------|------------|--------------|----------|-------------------------|----------------------------------|--------------------------------------|--|--|---|---|
| CATEGORY | RATE ELEMENTS | Interim | Zone | BCS | USOC | RATES (\$) | | | | Svc Order Submitted Elec per LSR | Svc Order Submitted Manually per LSR | Incremental Charge - Manual Svc Order vs. Electronic-1st | Incremental Charge - Manual Svc Order vs. Electronic-Add'l | Incremental Charge - Manual Svc Order vs. Electronic-Disc 1st | Incremental Charge - Manual Svc Order vs. Electronic-Disc Add'l |
| | | | | | | Rec | Nonrecurring | | Nonrecurring Disconnect | | | | | | |
| | | | | | | | First | Add'l | First | Add'l | SOMEc | SOMAN | SOMAN | SOMAN | SOMAN |
| | Physical Collocation - Security Access System - Security System per Central Office | | | CLO | PE1AX | 76.10 | | | | | | | | | |
| | Physical Collocation - Security Access System - New Access Card Activation, per Card | | | CLO | PE1A1 | 0.058 | 55.79 | 55.79 | | | | | | | |
| | Physical Collocation-Security Access System-Administrative Change, existing Access Card, per Request, per State, per Card | | | CLO | PE1AA | | 15.64 | 15.64 | | | | | | | |
| | Physical Collocation - Security Access System - Replace Lost or Stolen Card, per Card | | | CLO | PE1AR | | 45.74 | 45.74 | | | | | | | |
| | Physical Collocation - Security Access - Initial Key, per Key | | | CLO | PE1AK | | 26.29 | 26.29 | | | | | | | |
| | Physical Collocation - Security Access - Key, Replace Lost or Stolen Key, per Key | | | CLO | PE1AL | | 26.29 | 26.29 | | | | | | | |
| | Physical Collocation - Space Availability Report per premises | | | CLO | PE1SR | | 2,158.67 | 2,158.67 | | | | | | | |
| | POT Bay Arrangements prior to 6/1/99 - 2-Wire Cross-Connect, per cross-connect | | | UEANL,UEA,UDN,U DC,UAL,UHL,UCL,U EQ,CLO,UDL, UNCVX, UNCDX, UNCNX | PE1PE | 0.113 | | | | | | | | | |
| | POT Bay Arrangements prior to 6/1/99 - 4-Wire Cross-Connect, per cross-connect | | | UEANL,UEA,UDN,U DC,UAL,UHL,UCL,U EQ,CLO, USL, UNCVX, UNCDX | PE1PF | 0.23 | | | | | | | | | |
| | POT Bay Arrangements prior to 6/1/99 - DS1 Cross-Connect, per cross-connect | | | UEANL,UEA,UDN,U DC,UAL,UHL,UCL,U EQ,CLO,WDS1L,W DS1S, USL, U1TD1, UXTD1, UNC1X, ULDD1, USLEL, UNLD1 | PE1PG | 1.60 | | | | | | | | | |
| | POT Bay Arrangements prior to 6/1/99 - DS3 Cross-Connect, per cross-connect | | | UEANL,UEA,UDN,U DC,UAL,UHL,UCL,U EQ,CLO,UE3, U1TD3, UXTD3, UXTS1, UNC3X, UNCSX, ULDD3, U1TS1, ULDS1, UNLD3, UDL, UDLSX | PE1PH | 14.23 | | | | | | | | | |
| | POT Bay Arrangements prior to 6/1/99 - 2-Fiber Cross-Connect, per cross-connect | | | UEANL,UEA,UDN,U DC,UAL,UHL,UCL,U EQ,CLO, ULDO3, ULD12, ULD48, U1TO3, U1T12, U1T48, UDLO3, UDL12, UDF | PE1B2 | 48.57 | | | | | | | | | |
| | POT Bay Arrangements prior to 6/1/99 - 4-Fiber Cross-Connect, per cross-connect | | | UEANL,UEA,UDN,U DC,UAL,UHL,UCL,U EQ,CLO, ULDO3, ULD12, ULD48, U1TO3, U1T12, U1T48, UDLO3, UDL12, UDF | PE1B4 | 65.50 | | | | | | | | | |
| | Physical Collocation - Request Resend of CFA Information, per CLLI | | | CLO | PE1C9 | | 77.55 | | | | | | | | |
| | Nonrecurring Collocation Cable Records - per request | | | CLO | PE1CR | | 1,524.45 | 980.01 | 267.02 | | | | | | |
| | Nonrecurring Collocation Cable Records - VG/DS0 Cable, per cable record | | | CLO | PE1CD | | 656.37 | 656.37 | 379.70 | | | | | | |
| | Nonrecurring Collocation Cable Records - VG/DS0 Cable, per each 100 pair | | | CLO | PE1CO | | 9.65 | 9.65 | 11.84 | 11.84 | | | | | |

| COLLOCATION - Kentucky | | | | | | | | | | Attachment: 4 | | Exhibit: B | | | |
|-----------------------------|---|---------|------|-----------------------|-------|------------|----------------------------------|--------------------------------------|--|--|---|---|-------|--------------|-------|
| CATEGORY | RATE ELEMENTS | Interim | Zone | BCS | USOC | RATES (\$) | Svc Order Submitted Elec per LSR | Svc Order Submitted Manually per LSR | Incremental Charge - Manual Svc Order vs. Electronic-1st | Incremental Charge - Manual Svc Order vs. Electronic-Add'l | Incremental Charge - Manual Svc Order vs. Electronic-Disc 1st | Incremental Charge - Manual Svc Order vs. Electronic-Disc Add'l | | | |
| | | | | | | | | | | | | | Rec | Nonrecurring | |
| | | | | | | | | | | | | | | | |
| | | | | | | | | | | SOMEc | SOMAN | SOMAN | SOMAN | SOMAN | SOMAN |
| | Nonrecurring Collocation Cable Records - DS1, per T1TIE | | | CLO | PE1C1 | | 4.52 | 4.52 | 5.54 | 5.54 | | | | | |
| | Nonrecurring Collocation Cable Records - DS3, per T3TIE | | | CLO | PE1C3 | | 15.81 | 15.81 | 19.39 | 19.39 | | | | | |
| | Nonrecurring Collocation Cable Records - Fiber Cable, per 99 fiber records | | | CLO | PE1CB | | 169.63 | 169.63 | 154.85 | 154.85 | | | | | |
| | Physical Collocation - Security Escort - Basic, per Half Hour | | | CLO,CLORS | PE1BT | | 33.98 | 21.53 | | | | | | | |
| | Physical Collocation - Security Escort - Overtime, per Half Hour | | | CLO,CLORS | PE1OT | | 44.26 | 27.81 | | | | | | | |
| | Physical Collocation - Security Escort - Premium, per Half Hour | | | CLO,CLORS | PE1PT | | 54.54 | 34.09 | | | | | | | |
| | V to P Conversion, Per Customer Request-Voice Grade | | | CLO | PE1BV | 33.00 | | | | | | | | | |
| | V to P Conversion, Per Customer Request-DS0 | | | CLO | PE1BO | 33.00 | | | | | | | | | |
| | V to P Conversion, Per Customer Request-DS1 | | | CLO | PE1B1 | 52.00 | | | | | | | | | |
| | V to P Conversion, Per Customer request-DS3 | | | CLO | PE1B3 | 52.00 | | | | | | | | | |
| | V to P Conversion, Per Customer Request per VG Circuit Reconfigured | | | CLO | PE1BR | 23.00 | | | | | | | | | |
| | V to P Conversion, Per Customer Request per DS0 Circuit Reconfigured | | | CLO | PE1BP | 23.00 | | | | | | | | | |
| | V to P Conversion, Per Customer Request per DS1 Circuit Reconfigured | | | CLO | PE1BS | 33.00 | | | | | | | | | |
| | V to P Conversion, Per Customer Request per DS3 Circuit Reconfigured | | | CLO | PE1BE | 37.00 | | | | | | | | | |
| | V to P Conversion, Cable Pairs Assigned to Collo Space per 700 prs or fraction thereof | | | CLO | PE1B7 | 592.00 | | | | | | | | | |
| | Physical Collocation - Co-Carrier Cross Connects - Fiber Cable Support Structure, per cable, per linear ft. | | | CLO,UDF | PE1ES | 0.0012 | | | | | | | | | |
| | Physical Collocation - Co-Carrier Cross Connects - Copper/Coax Cable Support Structure, per cable, per lin. ft. | | | CLO, UE3, USL | PE1DS | 0.0018 | | | | | | | | | |
| | Physical Collocation - Co-Carrier Cross Connects - Application Fee, per application | | | CLO | PE1DT | | 584.20 | | | | | | | | |
| PHYSICAL COLLOCATION | | | | | | | | | | | | | | | |
| | Physical Collocation 2-Wire Cross Connect, Exchange Port 2-Wire Analog - Res | | | UEPSR | PE1R2 | 0.0333 | 24.68 | 23.68 | 12.14 | 10.95 | | 7.86 | | | |
| | Physical Collocation 2-Wire Cross Connect, Exchange Port 2-Wire Line Side PBX Trunk - Bus | | | UEPSP | PE1R2 | 0.0333 | 24.68 | 23.68 | 12.14 | 10.95 | | 7.86 | | | |
| | Physical Collocation 2-Wire Cross Connect, Exchange Port 2-Wire Voice Grade PBX Trunk - Res | | | UEPSE | PE1R2 | 0.0333 | 24.68 | 23.68 | 12.14 | 10.95 | | 7.86 | | | |
| | Physical Collocation 2-Wire Cross Connect, Exchange Port 2-Wire Analog - Bus | | | UEPSB | PE1R2 | 0.0333 | 24.68 | 23.68 | 12.14 | 10.95 | | 7.86 | | | |
| | Physical Collocation 2-Wire Cross Connect, Exchange Port 2-Wire ISDN | | | UEPSX | PE1R2 | 0.0333 | 24.68 | 23.68 | 12.14 | 10.95 | | 7.86 | | | |
| | Physical Collocation 2-Wire Cross Connect, Exchange Port 2-Wire ISDN | | | UEPTX | PE1R2 | 0.0333 | 24.68 | 23.68 | 12.14 | 10.95 | | 7.86 | | | |
| | Physical Collocation 4-Wire Cross Connect, Exchange Port 4-Wire ISDN DS1 | | | UEPEX | PE1R4 | 1.48 | 44.23 | 31.98 | 12.81 | 11.57 | | 7.86 | | | |
| ADJACENT COLLOCATION | | | | | | | | | | | | | | | |
| | Adjacent Collocation - Space Charge per Sq. Ft. | | | CLOAC | PE1JA | 0.0173 | | | | | | | | | |
| | Adjacent Collocation - Electrical Facility Charge per Linear Ft. | | | CLOAC | PE1JC | 5.35 | | | | | | | | | |
| | Adjacent Collocation - 2-Wire Cross-Connects | | | CLOAC | PE1P2 | 0.0258 | 24.68 | 23.68 | 12.14 | 10.95 | | | | | |
| | Adjacent Collocation - 4-Wire Cross-Connects | | | UEA,UHL,UDL,UCL,CLOAC | PE1P4 | 0.0515 | 24.88 | 23.82 | 12.77 | 11.46 | | | | | |
| | Adjacent Collocation - DS1 Cross-Connects | | | USL,CLOAC | PE1P1 | 1.37 | 44.23 | 31.98 | 12.81 | 11.57 | | | | | |
| | Adjacent Collocation - DS3 Cross-Connects | | | CLOAC | PE1P3 | 18.61 | 41.93 | 30.51 | 14.75 | 11.83 | | | | | |
| | Adjacent Collocation - 2-Fiber Cross-Connect | | | CLOAC | PE1F2 | 3.15 | 41.93 | 30.51 | 14.76 | 11.84 | | | | | |
| | Adjacent Collocation - 4-Fiber Cross-Connect | | | CLOAC | PE1F4 | 6.02 | 51.29 | 39.87 | 19.41 | 16.49 | | | | | |
| | Adjacent Collocation - Application Fee | | | CLOAC | PE1JB | | 3,165.50 | | 1.01 | | | | | | |
| | Adjacent Collocation - 120V, Single Phase Standby Power Rate per AC Breaker Amp | | | CLOAC | PE1FB | 5.44 | | | | | | | | | |
| | Adjacent Collocation - 240V, Single Phase Standby Power Rate per AC Breaker Amp | | | CLOAC | PE1FD | 10.88 | | | | | | | | | |

| COLLOCATION - Kentucky | | | | | | | | | | Attachment: 4 | | Exhibit: B | | | |
|---|--|---------|------|-------|-------|------------|--------------|--------|-------------------------|----------------------------------|--------------------------------------|--|--|---|---|
| CATEGORY | RATE ELEMENTS | Interim | Zone | BCS | USOC | RATES (\$) | | | | Svc Order Submitted Elec per LSR | Svc Order Submitted Manually per LSR | Incremental Charge - Manual Svc Order vs. Electronic-1st | Incremental Charge - Manual Svc Order vs. Electronic-Add'l | Incremental Charge - Manual Svc Order vs. Electronic-Disc 1st | Incremental Charge - Manual Svc Order vs. Electronic-Disc Add'l |
| | | | | | | Rec | Nonrecurring | | Nonrecurring Disconnect | | | | | | |
| | | | | | | | First | Add'l | First | Add'l | SOME C | SOMAN | SOMAN | SOMAN | SOMAN |
| | Adjacent Collocation - 120V, Three Phase Standby Power Rate per AC Breaker Amp | | | CLOAC | PE1FE | 16.32 | | | | | | | | | |
| | Adjacent Collocation - 277V, Three Phase Standby Power Rate per AC Breaker Amp | | | CLOAC | PE1FG | 37.68 | | | | | | | | | |
| PHYSICAL COLLOCATION IN THE REMOTE SITE | | | | | | | | | | | | | | | |
| | Physical Collocation in the Remote Site - Application Fee | | | CLOAS | PE1RA | | 617.78 | | 338.89 | | | | | | |
| | Cabinet Space in the Remote Site per Bay/ Rack | | | CLOAS | PE1RB | 219.67 | | | | | | | | | |
| | Physical Collocation in the Remote Site - Security Access - Key | | | CLOAS | PE1RD | | 26.29 | | | | | | | | |
| | Physical Collocation in the Remote Site - Space Availability Report per Premises Requested | | | CLOAS | PE1SR | | 232.64 | | | | | | | | |
| | Physical Collocation in the Remote Site - Remote Site CLLI Code Request, per CLLI Code Requested | | | CLOAS | PE1RE | | 75.40 | | | | | | | | |
| | Remote Site DLEC Data (BRSDD), per Compact Disk, per CO | | | CLOAS | PE1RR | | 233.42 | | | | | | | | |
| PHYSICAL COLLOCATION IN THE REMOTE SITE - ADJACENT | | | | | | | | | | | | | | | |
| | Remote Site-Adjacent Collocation - AC Power, per breaker amp | | | CLOAS | PE1RS | 6.27 | | | | | | | | | |
| | Remote Site-Adjacent Collocation - Real Estate, per square foot | | | CLOAS | PE1RT | 0.134 | | | | | | | | | |
| | Remote Site-Adjacent Collocation-Application Fee | | | CLOAS | PE1RU | | 755.62 | 755.62 | | | | | | | |
| NOTE: If Security Escort and/or Add'l Engineering Fees become necessary for remote site collocation, the Parties will negotiate appropriate rates. | | | | | | | | | | | | | | | |
| Note: Rates displaying an "R" in Interim column are interim and subject to rate true-up as set forth in General Terms and Conditions. | | | | | | | | | | | | | | | |

| ODUF/ADUF/EODUF/CMDS - Kentucky | | | | | | | | | | Attachment: 7 | | Exhibit: A | |
|--|---|---------|------|-----|------|------------|----------------------------------|--------------------------------------|--|--|---|---|-----|
| CATEGORY | RATE ELEMENTS | Interim | Zone | BCS | USOC | RATES (\$) | Svc Order Submitted Elec per LSR | Svc Order Submitted Manually per LSR | Incremental Charge - Manual Svc Order vs. Electronic-1st | Incremental Charge - Manual Svc Order vs. Electronic-Add'l | Incremental Charge - Manual Svc Order vs. Electronic-Disc 1st | Incremental Charge - Manual Svc Order vs. Electronic-Disc Add'l | |
| | | | | | | | | | | | | | Rec |
| | | | | | | | | | | | | | |
| | | | | | | | | | | | | | |
| ODUF/ADUF/OEDUF/CMDS | | | | | | | | | | | | | |
| ACCESS DAILY USAGE FILE (ADUF) | | | | | | | | | | | | | |
| | ADUF: Message Processing, per message | | | | N/A | 0.001857 | | | | | | | |
| | ADUF: Data Transmission (CONNECT:DIRECT), per message | | | | N/A | 0.0001245 | | | | | | | |
| OPTIONAL DAILY USAGE FILE (ODUF) | | | | | | | | | | | | | |
| | ODUF: Recording, per message | | | | N/A | 0.0000136 | | | | | | | |
| | ODUF: Message Processing, per message | | | | N/A | 0.002506 | | | | | | | |
| | ODUF: Message Processing, per Magnetic Tape provisioned | | | | N/A | 35.90 | | | | | | | |
| | ODUF: Data Transmission (CONNECT:DIRECT), per message | | | | N/A | 0.00010372 | | | | | | | |
| CENTRALIZED MESSAGE DISTRIBUTION SERVICE (CMDS) | | | | | | | | | | | | | |
| | CMDS: Message Processing, per message | | | | N/A | 0.004 | | | | | | | |
| | CMDS: Data Transmission (CONNECT:DIRECT), per message | | | | N/A | 0.001 | | | | | | | |
| ENHANCED OPTIONAL DAILY USAGE FILE (EODUF) | | | | | | | | | | | | | |
| | EODUF: Message Processing, per message | | | | N/A | 0.235889 | | | | | | | |
| Notes: If no rate is identified in the contract, the rate for the specific service or function will be as set forth in applicable BellSouth tariff or as negotiated by the Parties upon request by either Party. | | | | | | | | | | | | | |