

Case No. 2024-00382  
Old Bridge Gas Utility LLC  
Response to Commission Staff's First Request for Information

**Commission Staff 1-1:**

Refer to Joint Application, page 4.

- a. Provide a description of all professional experience Mr. Sayers and Ms. Sayers have in the propane or gas industry. In these descriptions, provide the company, job title, and a description of all responsibilities.
- b. Provide a description of all previous managerial experience of Mr. Sayers and Ms. Sayers.
- c. Provide a description of any experience or trainings the Sayers have with regulated utilities.

**Response:**

- a. Mr. Sayers has 27 years of experience in the propane industry. Most recently, Mr. Sayers served as Vice President of Retail Operations, nationwide, at Ferrellgas, a company serving over 600,000 customers and operated by 4,000 employees. In this role, Mr. Sayers oversaw 2,200 employees and was responsible for \$350,000,000 EBITDA. A complete enumeration of his experience in this role, and previous roles, are provided in detail in his professional résumé.
- b. Mr. Sayers was a career employee at Ferrellgas and advanced in the company throughout his tenure. Early in his career Mr. Sayers worked as a general manager and advanced to Vice President of Retail Operations, nationwide. A complete list of his managerial experience is available in his professional résumé.
- c. Mr. Sayers has vast experience in the propane industry. While Mr. Sayers has not had any specific training in the regulated utility space, he is well versed in the propane industry and general business operations.

Case No. 2024-00382  
Old Bridge Gas Utility LLC  
Response to Commission Staff's First Request for Information

See attached: Attachment 1-1 – Tim Sayers' Résumé.

**Witness:** Tim Sayers

# Timothy J. Sayers

3660 Horsemint Trail  
Lexington, Kentucky 40509

(859) 420-3772

[Timothyjsayers@gmail.com](mailto:Timothyjsayers@gmail.com)

[https://www.linkedin.com/in/  
timothy-sayers-61883011b](https://www.linkedin.com/in/timothy-sayers-61883011b)

## SUMMARY

Results-driven operations executive with over 27 years of experience in the propane industry, serving most recently as Vice President of Retail Operations at Ferrellgas. Proven track record of exceeding expectations, driving operational efficiency, and fostering team growth. Seeking opportunities to leverage leadership and problem-solving skills in a dynamic environment.

## EXPERIENCE

### **Ferrellgas, Nationwide — Vice President of Retail Operations**

AUGUST 2020-MARCH 2024

- Exceeded expectations by driving operational excellence and strategic growth initiatives, reporting directly to the CEO
- Led successful integration of multiple acquisitions and partnered with business analytics team to create KPIs and ensure achievement of pro forma.
- Leadership and oversight of Ferrell North America transportation division. Ensured the safe, economic, adequate supply to all company locations while utilizing 140 company power units. Direct reports were Senior Director of Supply Transportation and Product Coordinator team.
- Mentored and sponsored several classes of the management development program, fostering young leadership talent within the organization.
- Assured company compliance with national, state, local, and industry safety regulations.
- Implemented best-in-class operations and nurtured new region and general managers, contributing to organizational success.
- Ultimate responsibility for the daily operations of 800+ retail locations and 2,200 employees on a nationwide scale.
- Reviewed financial statements, sales reports, and productivity metrics to ensure financial goals were attained while maximizing efficiency and achieving KPI benchmarks.
- Implemented successful business strategies to reduce operating expenses, increase revenue and target new markets.
- Selected and implemented telematics solution for company fleet to maximize efficiency and increase vehicle up-time.
- Provided leadership to the acquisitions team. In this role, I oversaw deal sourcing, due diligence and pro forma plans. Provided field approval for CEO and board review.

### **Ferrellgas, Northeast United States — Northeast Region Vice President**

APRIL 2015-JULY 2020

- Formulated policies that improved operational efficiency and productivity
- Directed business development initiatives, including acquisition and joint venture agreements
- Collaborative leadership in union and non-union settings
- Reviewed and approved CapEx requests for field projects
- Advised senior executives on approaches for resolving complex issues impacting operations
- Directed annual budgeting processes and verified alignment with company objectives
- Hired new managers to drive sustainable business growth
- Cultivated and maintained industry and customer relationships to capitalize on opportunities and maximize business success

## SKILLS

Strategic Planning  
Operations Management  
Leadership Development  
Financial Management  
Problem Solving  
Communication  
Team Building  
Project Management  
Acquisitions Integration  
Customer Relationships  
Business Forecasting  
Transportation Oversight

## AWARDS

**2015, James E Ferrell  
Chairman Leadership Award**

**2021, 20222, 2023 Record  
Fiscal Years**

**Chairman Kentucky Propane  
Education and Research  
Council**

**State Director National  
Propane Gas Association  
(Rhode Island) 2010-2012**

## CERTIFICATIONS

Commercial Driver's License  
(CDL B) with Hazmat and  
Tanker Endorsements

References Upon Request

## EDUCATION

### **Hanover College, Hanover, Indiana —*Communication***

AUGUST 1993-MAY 1997

Bachelor of Arts

## PROFESSIONAL DEVELOPMENT

### **Ferrellgas — *June 1997-March 2024***

Continual advancement within Ferrellgas from District Manager Trainee to Vice President of Retail Operations including roles as Divisional Vice President, Region Vice President, Vice President of Business Development, Area Manager, District Manager, General Manager

Case No. 2024-00382  
Old Bridge Gas Utility LLC  
Response to Commission Staff's First Request for Information

**Commission Staff 1-2:**

Refer to Joint Application, page 1. Explain why a decision was made to form a new limited liability company (LLC), Old Bridge Gas, rather than have Mr. Sayers and/or Ms. Sayers take over Mr. Robert's ownership interest in CPS.

**Response:** Old Bridge Gas Utility LLC ("Old Bridge LLC") was formed based on advice of counsel and accounting professionals. Forming a limited liability company prevents any potential Old Bridge Utility (the "Utility") liabilities, current or future, from attaching to Mr. Sayers and/or Ms. Sayers as personal liabilities. Further, the distinct legal entity allows the Old Bridge LLC members to segregate the utility's operations from the operating entity, Sayers LPG LLC, which provides tax advantages and other strategic business advantages for Mr. Sayers and/or Ms. Sayers and Sayers LPG LLC.

**Witness:** Tim Sayers

Case No. 2024-00382  
Old Bridge Gas Utility LLC  
Response to Commission Staff's First Request for Information

**Commission Staff 1-3:**

Refer to Joint Application, pages 3–4. Explain in detail what role Old Bridge Gas expects Russmar to play in ensuring that Old Bridge Gas complies with all applicable Commission orders, regulations, and statutes. If a contract with Russmar in place, include a copy of that contract as a part of the response.

**Response:** CPS entered a contract with Russmar to provide the Utility an annual leak survey, an annual valve inspection, 811 locates, odor readings, patrolling, and emergency response and operator qualifications. Subject to the Commission's approval of the transfer, Old Bridge LLC intends to enter a contract for substantially similar services with Russmar or an equivalent service provider to continue providing the Utility ongoing support services.

**Witness:** Tim Sayers and Michael Roberts

Case No. 2024-00382  
Old Bridge Gas Utility LLC  
Response to Commission Staff's First Request for Information

**Commission Staff 1-4:**

Provide an accounting of all tangible and intangible assets to be transferred to Old Bridge Gas.

**Response:** For a general accounting of the Utility's tangible and intangible assets, please see the Joint Application Exhibit 1, pages 1-2, Section 1.

**Real Property:** *See* Joint Application, Exhibit 1, page 13, Exhibit 1.1(a), which includes the title to or right, title and interest to use Lot of the Final Plat Amendment 1, Old Bridge Section 5, of Record in the Boyle County Clerk's Office at Plat 1462B, for the purpose of locating a propane storage tank. All of the right, title, and interest, in and to those easements and rights of way shown or identified on the attached plats of Old Bridge Subdivision in Boyle County, Kentucky, some of which plats are of record at Reference File Numbers 325B, 326A, 332B, 356B, 357A, 443B, 690B, 970B, 980B, 1323A, 1462A, 1462B, and 1508A in the Boyle County Court Clerk's office.

**Personal Property:** *See* Joint Application, Exhibit 1, page 14, Exhibit 1.1(b), which includes an 18,000-gallon aboveground supply tank; roughly 5,280 2" main (plastic) units; three 1,000-gallon underground supply tanks; and 65 customer meters.

**Intangible Assets:** The Joint Applicants are not aware of any intangible assets that will be transferred.

**Witness:** Tim Sayers and Michael Roberts



Case No. 2024-00382  
Old Bridge Gas Utility LLC  
Response to Commission Staff's First Request for Information

**Commission Staff 1-5:**

Refer to Joint Application, Exhibit 1, page 2, Section 1.2.

- a. Explain why the decision was made to exclude accounts receivable accrued prior to the Closing date from the transaction.
- b. Explain how Old Bridge Gas plans to pay for its operational costs and expenses without the accounts receivables accrued prior to the closing date.

**Response:**

a. The Joint Applicants contemporaneously entered both a Purchase and Sale Agreement and a Management Agreement when negotiating the terms of the Utility's transfer and acquisition. The Management Agreement between Old Bridge LLC and CPS specifically precludes Old Bridge LLC from having final decision-making authority for the Utility's management, operation, or ownership of assets until the Commission has approved the transfer. Old Bridge LLC also assumed responsibility for recurring Utility costs, such as the cost of wholesale propane, during the term pending the Commission's approval. Per the Management Agreement, Old Bridge LLC is also entitled to retain the revenues generated during this term. Old Bridge LLC and CPS chose to exclude accounts receivable accrued prior to the execution of the Purchase and Sale Agreement because Old Bridge LLC is retaining revenue prior the Commission's approval of the transaction. Further, the majority of the Utility's customers pay their bills via credit cards on file and the balance for outstanding accounts receivables is insignificant. Both the Purchase and Sale Agreement and Management Agreement have been previously filed with the Commission. *See* Joint Application Exhibit 1, Purchase and Sale Agreement, pages 1-14; Joint Application Exhibit 1, Management Agreement, pages 15-20.

Case No. 2024-00382  
Old Bridge Gas Utility LLC  
Response to Commission Staff's First Request for Information

b. Old Bridge LLC is entitled to retain customer revenues during the term preceding the Commission's approval of the transaction, as outlined in the Management Agreement. The collected revenues will be used to pay for operational costs and expenses prior to the closing date. *See* Joint Application Exhibit 1, pages 15-20.

**Witness:** Tim Sayers

Case No. 2024-00382  
Old Bridge Gas Utility LLC  
Response to Commission Staff's First Request for Information

**Commission Staff 1-6:**

Refer to Joint Application, Exhibit 1 at 4. Provide all permits acquired by Old Bridge Gas related to this acquisition.

**Response:** Sayers LPG LLC has a Kentucky Liquefied Petroleum Gas License. Old Bridge LLC has not procured a Kentucky Liquefied Petroleum Gas License. Upon the approval of the transfer, Old Bridge LLC will enter into an agreement with Sayers LPG LLC to operate the Utility. As Sayers LPG LLC will be the Utility's operator, it is the appropriate permitted entity. See attached: Attachment 1-6 – Sayers LPG LLC Kentucky Liquefied Petroleum Gas License.

**Witness:** Tim Sayers



COMMONWEALTH OF KENTUCKY  
DEPARTMENT OF HOUSING, BUILDINGS & CONSTRUCTION  
LICENSING BRANCH  
500 Mero St., 1st Floor  
Frankfort KY, 40601-1298  
PHONE NUMBER (502) 573-2002



Liquefied Petroleum Gas Class A License Number: LLP0001443  
Sayers LPG LLC - 160 Sulphur Springs Rd Lebanon, KY 40033-8723

Expires: 11/30/2025

Location Owner: Timothy J Sayers

THIS LOCATION IS HEREBY PERMITTED TO ENGAGE IN THE LIQUEFIED PETROLEUM GAS BUSINESS AS REQUESTED AND IN ACCORDANCE WITH THE KENTUCKY REVISED STATUTES SECTION 234.120. A NEW LICENSE IS REQUIRED IF OWNERSHIP CHANGES FROM THE LOCATION OWNER LISTED ABOVE.

Sayers LPG LLC  
160 Sulphur Springs Rd  
Lebanon, KY 40033-8723

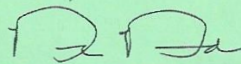
  
Rick Rand - Commissioner



COMMONWEALTH OF KENTUCKY  
DEPARTMENT OF HOUSING, BUILDINGS & CONSTRUCTION  
LICENSING BRANCH  
500 Mero St., 1st Floor  
Frankfort KY, 40601-1298  
PHONE NUMBER (502) 573-2002



Liquefied Petroleum Gas Class A License Number: LLP0001443  
Sayers LPG LLC - 160 Sulphur Springs Rd Lebanon, KY 40033-8723

Expires: 11/30/2025

Location Owner: Timothy J Sayers

THIS LOCATION IS HEREBY PERMITTED TO ENGAGE IN THE LIQUEFIED PETROLEUM GAS BUSINESS AS REQUESTED AND IN ACCORDANCE WITH THE KENTUCKY REVISED STATUTES SECTION 234.120. A NEW LICENSE IS REQUIRED IF OWNERSHIP CHANGES FROM THE LOCATION OWNER LISTED ABOVE.

Timothy J Sayers  
215 Twin Eagles Ln  
Lebanon, KY 40033-9408

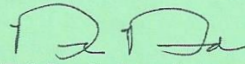
  
Rick Rand - Commissioner

Case No. 2024-00382  
Old Bridge Gas Utility LLC  
Response to Commission Staff's First Request for Information

**Commission Staff 1-7:**

Refer to Joint Application, Exhibit 1, page 14. Provide the remaining and original useful life of each asset listed.

**Response:** The Utility system was initially installed in 1989. At present, the Joint Applicants do not have complete records of each Utility asset and records of replacement or updates to each asset. However, using industry standards, the Joint Applicants anticipate the below assets will have useful lifespans on par with industry averages. The Joint Applicants believe the system to be in working condition and is not currently in need of repair or part replacement. However, upon approval of the transfer, Old Bridge LLC will make all necessary replacements and upgrades to the system.

- The 18,000-gallon aboveground steel supply tank typically has an indefinite useful life. The propane is stored inside the tank and the paint on the outside of the tank protects the steel from corrosion. The valves on the tank may be replaced, if necessary, which would not materially impact the useful life of the tank.
- The poly tubing, of which the Utility has roughly 5,280 2" main pieces, has a useful life of up to 100 years.
- The three 1,000-gallon underground supply tanks also have an indefinite useful life because of the cathodic protection to prevent the tank from corroding.
- The utility's 65 customer meters have a standard useful life of 25 years. The Utility's meters may be reaching the end of their useful life. As the meters expire, Old Bridge LLC will replace the meters.

**Witness:** Tim Sayers

Case No. 2024-00382  
Old Bridge Gas Utility LLC  
Response to Commission Staff's First Request for Information

**Commission Staff 1-8:**

Refer to Joint Application, Exhibit 2, page 8.

- a. Explain whether Old Bridge Gas expects to keep the three full time employees on staff.
- b. Explain whether Old Bridge Gas expects to hire any additional employees.

**Response:** Upon approval of the transfer, Sayers LPG LLC and Old Bridge LLC will enter into an agreement for Sayers LPG LLC to operate the Utility. Sayers LPG LLC will employ three individuals: Chuck Howell, current driver and service technician for the Utility, Jared Sayers, and Tim Sayers. At present, Sayers LPG LLC has no intention of hiring additional employees for the operation of the Utility.

**Witness:** Tim Sayers

Case No. 2024-00382  
Old Bridge Gas Utility LLC  
Response to Commission Staff's First Request for Information

**Commission Staff 1-9:**

Refer to Application, pages 4–5. Explain what, if any, impact this transfer and acquisition would have on customers, including any potential impacts on customer rates or billing.

**Response:** Old Bridge LLC intends to continue providing the same propane service to its customers as they received under CPS. Old Bridge LLC does not anticipate its customers would experience any negative impact in service from the transfer and acquisition as it relates to the quality of propane services they receive. Customers will experience administrative changes such as a change in address for submitting payment and the identity of the payee. Pursuant to the Management Agreement executed by the Joint Applicants, Old Bridge LLC has already begun implementing these administrative changes in its Utility management. At present, Old Bridge LLC has no intention of seeking a rate increase.

**Witness:** Tim Sayers

Case No. 2024-00382  
Old Bridge Gas Utility LLC  
Response to Commission Staff's First Request for Information

**Commission Staff 1-10:**

Refer to Application, pages 4–5. Describe what, if any, communications Joint Applicants have had with customers in regard to the proposed transfer and acquisition. Include any notices or information sent to customers.

**Response:** The Joint Applicants have not yet had any formal communication with Utility customers regarding the transfer. The Joint Applicants intend to notify customers of the transfer upon Commission approval. Pursuant to the Management Agreement, Jared Sayers, a Sayers LPG LLC employee, is already working with Utility customers regarding billing and other service questions, and he is informally notifying customers of the pending transfer.

**Witness:** Tim Sayers



Case No. 2024-00382  
Old Bridge Gas Utility LLC  
Response to Commission Staff's First Request for Information

**Commission Staff 1-11**

Refer to Application, pages 4–5. If the Joint Application is accepted, identify and describe any future communications Joint Applicants plan on having with customers to ensure a smooth transition. Include when the Joint Applicants plan to make these communications and what method of communication Joint Applicants plan to use.

**Response:** Old Bridge LLC will provide Utility customers a letter explaining the details of the Utility transfer upon Commission approval. Old Bridge LLC will mail this letter to its customers within 30 days of the approval of the transaction. Old Bridge LLC will also provide its customers with a phone number they may use to contact a representative of the Utility with any service, billing, or other related questions.

**Witness:** Tim Sayers

Case No. 2024-00382  
Old Bridge Gas Utility LLC  
Response to Commission Staff's First Request for Information

**Commission Staff 1-12:**

Provide a list of all current liabilities of Old Bridge Gas.

**Response:** Old Bridge LLC has limited current liabilities. Bank of the Bluegrass approved a \$584,000 loan to co-borrowers Sayers LPG LLC and Old Bridge LLC. Bank of the Bluegrass has advanced \$484,000 to Sayers LPG LLC for the purchase of CPS propane distribution business assets. Upon transaction approval, Bank of the Bluegrass will advance a \$100,000 bank note to Old Bridge LLC to fulfill the Purchase and Sale Agreement Old Bridge LLC entered with CPS for the payment in full of the Utility. Based on the Management Agreement, Old Bridge LLC is responsible for the wholesale cost of propane and retains generated revenue during the term prior to the approval of the transfer. Upon approval of the transfer, Old Bridge LLC will enter into an agreement with Sayers LPG LLC to operate the Utility, and these operating liabilities will shift to Sayers LPG LLC upon agreement following the approval of the transfer.

**Witness:** Tim Sayers

Case No. 2024-00382  
Old Bridge Gas Utility LLC  
Response to Commission Staff's First Request for Information

**Commission Staff 1-13:**

Provide a list of all current liabilities of Sayers LPG LLC.

**Response:** Bank of the Bluegrass approved a \$584,000 loan to co-borrowers Sayers LPG LLC and Old Bridge LLC. Bank of the Bluegrass has advanced \$484,000 to Sayers LPG LLC for the purchase of CPS propane distribution business assets. Upon approval of the transaction, an additional \$100,000 will be advanced to Old Bridge LLC to fund the acquisition of the Utility. Sayers LPG LLC will also be responsible for the operation of the Utility and will incur the wholesale cost of propane for its customers; employee salaries for Jared Sayers, Chuck Howell, and Tim Sayers; and other generally recurring business expenses for the operation of the Utility upon the approval of the transfer.

**Witness:** Tim Sayers

Case No. 2024-00382  
Old Bridge Gas Utility LLC  
Response to Commission Staff's First Request for Information

**Commission Staff 1-14:**

Explain whether Old Bridge Gas would expect to hire an accountant or other qualified professional to conduct an audit of CPS's assets, if the application is approved. If an audit of CPS has already occurred or been provided as part of this proposed transaction, provide that document.

**Response:** Old Bridge LLC plans to hire a certified professional accountant to maintain its financial records and prepare all statements necessary for state and federal regulation. CPS did not conduct a prior audit of the Utility's financial or other assets. CPS provided Old Bridge LLC with the Utility's financial statements for the three previous years during due diligence in this transaction. CPS also hired Russmar to conduct an audit of the Utility's physical assets. Old Bridge LLC reviewed both the financial statements and the Russmar asset audit prior to entering the Purchase and Sale Agreement.

See attached: Attachment 1-14 – Russmar Asset Audit.

**Witness:** Tim Sayers



2371 Irvine Road, Richmond, KY 40475  
(TEL.) 859-623-0112 (FAX.) 859-626-0822  
A MEASURE OF EXCELLENCE IN UTILITY PROFESSIONAL SERVICES

Adrian Roberts  
Commercial Propane Services  
160 Sulpher Springs Rd.  
Lebanon Ky, 40033

RE: Patrolling

RussMar Utility Management conducted a patrolling survey on 11/7/24, no concerns were identified.

Sincerely,

A handwritten signature in black ink, appearing to be "A. Roberts", written over a horizontal line.



Company: Russmar Utility Management

Date: 11/08/2024

Location: *OLD Bridge, Danville KY*

Odor levels and/or Odorator Readings

Threshold (1<sup>st</sup> Detectable)

\_\_\_\_\_ Nil

\_\_\_\_\_ Barely Detectable

\_\_\_\_\_ Readily Detectable

      X       Strong

Remarks: (Odorator Reading) *Our NG odorator is not considered accurate for PG but the Ethyl mercaptan is very detectable by nose 20' away at a very minor amt.*

Observed: *John Flores*









Customer Name		Phone #		Customer Account #		No. 0858			
Installer Name		Date Received		Date Installed					
Address		City/County		State		Date			
129 old bridge rd		Danville		Ky		11-6-24			
		Case #	Grade 1		Grade 2	Grade 3			
		Meter #			Inside				
		Manufacture #			Outside				
		#1 Riser	#2 HP Cock	#3 Regulator					
		#4 LP Cock	#5 Inlet Loop	#6 Inlet Cap/Swivel					
		#7 Out Cap/Swivel	#8 Outlet Loop	#9 Fuel Line Fitting					
		#10 Gas Meter	#11 Index	#12 Fuel Line					
DETECTION	LOCATION		SOIL SUB	CGI/EGD	PRESSURE	SURFACE	PIPE	SIZE	WEATHER
Mobile F1	Inside Bldg	Main	Rock	%Gas	(0-1)	Grass	Steel	.5-2.0	Clear
Flame Pack	Outside Bldg	Service	Cinder	LEL	(1-30)	Dirt	PE	2.0-3.0	Wet
Visual	Manhole	Tap	Clay	UEL	(31-60)	Asphalt	Cast Iron	3.0-4.0	Hot (85-100)
CCGI/EGD	Undergrnd	Valve	Loam	PPM	(61-99.9)	Concrete	CSST	6.0-8.0	Cold (0-40)
Smell	Atmosphere	Meter	Sand		(100-399)	Sidewalk	PVCB	10.2-12.0	
LEAK CAUSE	COMPONENT /EXPLANATION		PART OF SYSTEM	TYPE MATERIAL		LOCATION AREA		REPAIR DATA	
Corrosion	Pipe		Transmission	Steel		Residential		1-5	Bare
Outside Force	Valve		Main	Cast Iron		Rural		5-Greater	Coated
Const/Defect	Fitting		Service	Ductile Iron		Commercial		Date Repaired:	
Material Defect	Regulator		Meter Set	Copper		Industrial		Repaired By:	
Other	Tap Connection		Customer Pipe	Plastic				Date Rechecked:	

Signature: John Florid-Warren

Date: 11-6-24

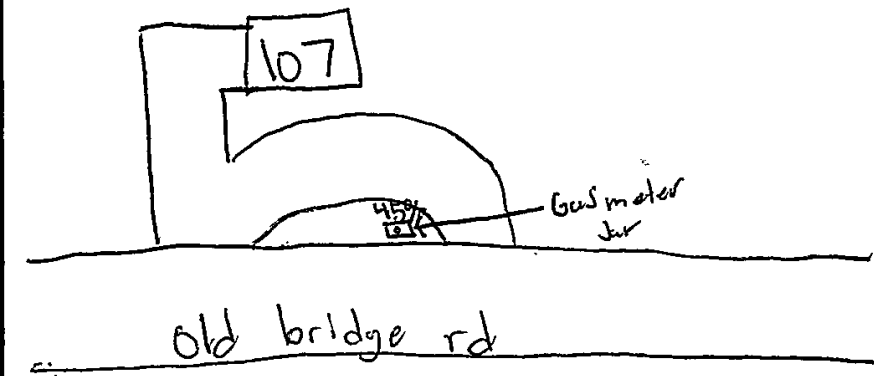
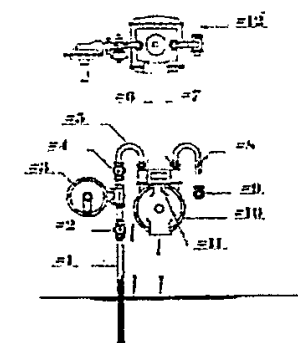
Customer Name		Phone #		Customer Account #		No. 0857	
Installer Name		Date Received		Date Installed			
Address		City/County		State		Ky	
107 old bridge rd		Danville					
				Case #	Date 11-06-24		
				Classification	Grade 1	Grade 2	Grade 3
				Meter #	Inside		
				Manufacture #	Outside		
							
#4 LP Cock	#5 Inlet Loop	#6 Inlet Cap/Swivel					
#7 Out Cap/Swivel	#8 Outlet Loop	#9 Fuel Line Fitting					
#10 Gas Meter	#11 Index	#12 Fuel Line					

DETECTION	LOCATION		SOIL SUB	CGI/EGD	PRESSURE	SURFACE	PIPE	SIZE	WEATHER
Mobile F1	Inside Bldg	Main	Rock	%Gas	(0-1)	Grass	Steel	.5-2.0	Clear
Flame Pack	Outside Bldg	Service	Cinder	LEL	(1-30)	Dirt	PE	2.0-3.0	Wet
Visual	Manhole	Tap	Clay	UEL	(31-60)	Asphalt	Cast Iron	3.0-4.0	Hot (85-100)
CCGI/EGD	Undergrnd	Valve	Loam	PPM	(61-99.9)	Concrete	CSST	6.0-8.0	Cold (0-40)
Smell	Atmosphere	Meter	Sand		(100-399)	Sidewalk	PVCB	10.2-12.0	

LEAK CAUSE	COMPONENT /EXPLANATION	PART OF SYSTEM	TYPE MATERIAL	LOCATION AREA	REPAIR DATA
Corrosion	Pipe	Transmission	Steel	Residential	1-5 Bare
Outside Force	Valve	Main	Cast Iron	Rural	5-Greater Coated
Const/Defect	Fitting	Service	Ductile Iron	Commercial	Date Repaired:
Material Defect	Regulator	Meter Set	Copper	Industrial	Repaired By:
Other	Tap Connection	Customer Pipe	Plastic		Date Rechecked:

Signature: John Florek

Date: 11-6-24

Customer Name	Phone #	Customer Account #	No.	0851
Installer Name	Commercial propane		Date Received	Date Installed
Address	103 old bridge Rd	City/County	Danville	State
			Ky	

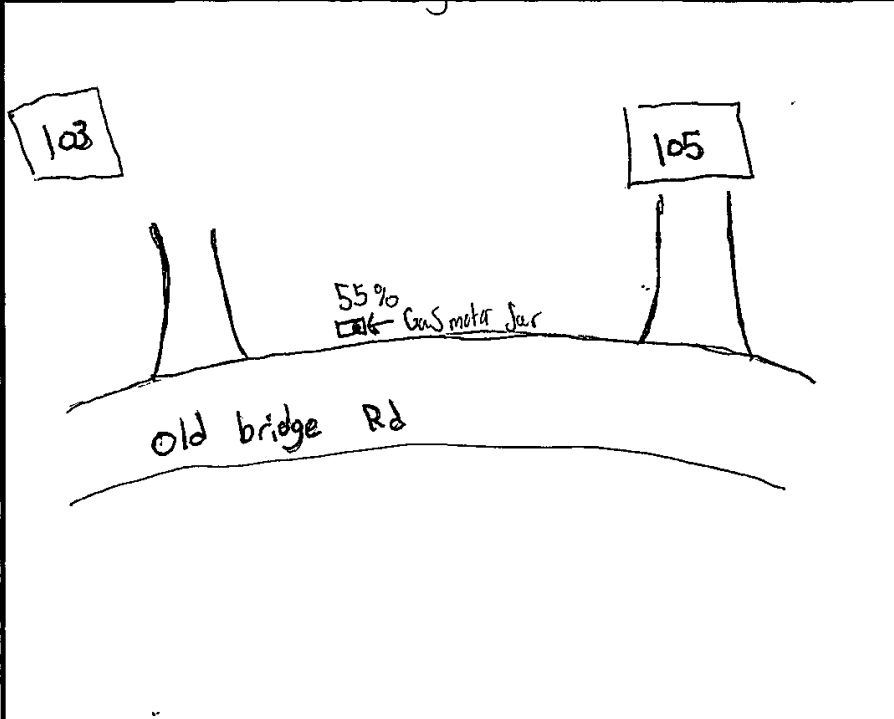

Case #	Date	11-6-24	
Classification	Grade 1	Grade 2	Grade 3
Meter #	Inside		
Manufacture #	Outside		

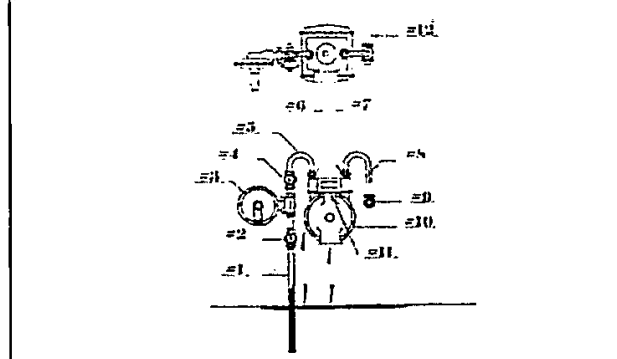

#1 Riser	#2 HP Cock	#3 Regulator
#4 LP Cock	#5 Inlet Loop	#6 Inlet Cap/Swivel
#7 Out Cap/Swivel	#8 Outlet Loop	#9 Fuel Line Fitting
#10 Gas Meter	#11 Index	#12 Fuel Line

DETECTION	LOCATION		SOIL SUB	CGI/EGD	PRESSURE	SURFACE	PIPE	SIZE	WEATHER
Mobile Fl	Inside Bldg	Main	Rock	%Gas	(0-1)	Grass	Steel	.5-2.0	Clear
Flame Pack	Outside Bldg	Service	Cinder	LEL	(1-30)	Dirt	PE	2.0-3.0	Wet
Visual	Manhole	Tap	Clay	UEL	(31-60)	Asphalt	Cast Iron	3.0-4.0	Hot (85-100)
CCGI/EGD	Undergrnd	Valve	Loam	PPM	(61-99.9)	Concrete	CSST	6.0-8.0	Cold (0-40)
Smell	Atmosphere	Meter	Sand		(100-399)	Sidewalk	PVCB	10.2-12.0	

LEAK CAUSE	COMPONENT / EXPLANATION	PART OF SYSTEM	TYPE MATERIAL	LOCATION AREA	REPAIR DATA
Corrosion	Pipe	Transmission	Steel	Residential	1-5 Bare
Outside Force	Valve	Main	Cast Iron	Rural	5-Greater Coated
Const/Defect	Fitting	Service	Ductile Iron	Commercial	Date Repaired:
Material Defect	Regulator	Meter Set	Copper	Industrial	Repaired By:
Other	Tap Connection	Customer Pipe	Plastic		Date Rechecked:

Signature: John Phillip Warren

Date: 11-6-24

COMMONWEALTH OF KENTUCKY  
BEFORE THE PUBLIC SERVICE COMMISSION

In the Matter of:

JOINT APPLICATION OF COMMERCIAL PROPANE )  
SERVICE, LLC AND OLD BRIDGE GAS UTILITY )  
LLC FOR APPROVAL OF OLD BRIDGE GAS ) Case No. 2024-00382  
UTILITY LLC'S ACQUISITION OF COMMERCIAL )  
PROPANE SERVICE LLC'S UTILITY ASSETS IN )  
OLD BRIDGE SUBDIVISION, DANVILLE, )  
KENTUCKY )

---

CERTIFICATION

---

This is to certify that I have supervised the preparation of the Joint Applicants' responses to the Public Service Commission Staff's Initial Request for Information and that the responses on which I am identified as a sponsoring witness are true and accurate to the best of my knowledge, information, and belief after reasonable inquiry.

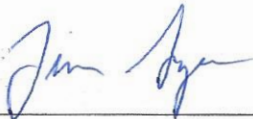

Tim Sayers

1-16-2025

Date