

**COMMONWEALTH OF KENTUCKY
BEFORE THE PUBLIC SERVICE COMMISSION**

In the matter of:

THE APPLICATION OF EAST KENTUCKY NETWORK,)
LLC FOR THE ISSUANCE OF A CERTIFICATE OF)
PUBLIC CONVENIENCE AND NECESSITY TO) CASE NO. 2024-00089
CONSTRUCT A TOWER IN MORGAN COUNTY,)
KENTUCKY)

East Kentucky Network, LLC d/b/a Appalachian Wireless, was granted authorization to provide cellular service in the KY-9 Cellular Market Area (CMA451) by the Federal Communications Commission (FCC). The FCC license is included as Exhibit 1. East Kentucky Network, LLC merger documents were filed with the Commission on February 2, 2001 in Case No. 2001-022. East Kentucky Network, LLC is a Kentucky Limited Liability Company that was organized on June 16, 1998. East Kentucky Network, LLC is in good standing with the state of Kentucky.

In an effort to improve service in Morgan County, pursuant to KRS 278.020 Subsection 1 and 807 KAR 5:001, East Kentucky Network, LLC is seeking the Commission's approval to construct a 190-foot self-supporting tower on a tract of land located at 7485 Route 7, West Liberty, Morgan County, Kentucky (38° 00' 03.04"N 83° 16' 37.78"W). A map and detailed directions to the site can be found in Exhibit 7.

Construction of the proposed tower is required by public convenience and necessity. Due to increasing demand for telecommunications service, the proposed tower is necessary to provide adequate coverage. The proposed tower will improve service in Morgan County by providing an interconnection between East Kentucky Network, LLC's other sites thereby forming a cohesive network.

Exhibit 2 is a list of all Property owners according to the Property Valuation Administrator's record who own property within 500 feet of the proposed Tower and all property owners who own

property contiguous to the property upon which construction is proposed in accordance with the Property Valuation Administrator's record.

Pursuant to 807 KAR 5:063 Section 1(1)(l), Section 1(m) and Section 2, all affected property owners according to the Property Valuation Administrator's record who own property within 500 feet of the proposed Tower or contiguous to the property upon which construction is proposed were notified by certified mail return receipt requested of East Kentucky Network, LLC's proposed construction and informed of their right to intervene. They were given the docket number under which this application is filed. Enclosed in Exhibit 2 is a copy of that notification.

Morgan County has no formal local planning unit. In absence of this unit, the Morgan County Judge Executive's office was notified by certified mail, return receipt requested, of East Kentucky Network, LLC's proposal and informed of their right to intervene. The Morgan County Judge Executive's office was also given the docket number under which this application is filed. Enclosed in Exhibit 3 is a copy of that notification.

Notice of the location of the proposed construction will be published in The Licking Valley Courier, April 11, 2024 edition. Enclosed is a copy of that notice in Exhibit 3. The Licking Valley Courier is the newspaper with the largest circulation in Morgan County.

A geologist was employed to determine soil and rock types and to ascertain the distance to solid bedrock. The geotechnical report is enclosed as Exhibit 4.

A copy of the tower design information is enclosed as Exhibit 5. The proposed tower has been designed by engineers at World Tower Company and will be constructed under their supervision. Their qualifications are evidenced in Exhibit 5 by the seal and signature of the registered professional engineer responsible for this project.

The tower will be erected by S & S Tower Services of St. Albans, West Virginia. S & S Tower Services has vast experience in the erection of communications towers. Their qualifications are described in Exhibit 13.

Enclosed in Exhibit 6 is the FAA's determination of no hazard and a communication received from KAZC affirming no permit is required for this structure.

No Federal Communications Commission approval is required prior to construction of this facility. Once service is established from this tower we must immediately notify the Federal Communications Commission of its operation. Prior approval is needed only if the proposed facility increases the size of the cellular geographic service area. This cell site will not expand the cellular geographic service area.

Two notice signs meeting the requirements prescribed by 807 KAR 5:063, Section 1(2), measuring at least two (2) feet in height and four (4) feet in width and containing all required language in letters of required height, have been posted, one at a visible location on the proposed site and one on the nearest public road. The two signs were posted on April 9, 2024, and will remain posted for at least two weeks after filing of this application as specified.

Enclosed in Exhibit 8 is a copy of East Kentucky Network, LLC's Memorandum of Lease for the site location along with a lot description.

The proposed construction site is on a rugged, tree covered mountainside.

East Kentucky Network, LLC's operation will not affect the use of nearby land nor its value. No more suitable site exists in the area. A copy of the search area map is enclosed in Exhibit 7. No other tower capable of supporting East Kentucky Network, LLC's load exists in the general area; therefore, there is no opportunity for co-location of our facilities with anyone else.

Enclosed, and filed as Exhibit 9 is a survey of the proposed tower site signed by a Kentucky registered professional engineer.

Exhibit 10 is a map in one (1) inch equals 200 feet scale identifying every structure and every owner of real estate within 500 feet of the proposed tower and all property owners who own contiguous property to the property upon which construction is proposed.

Exhibit 11 contains a vertical sketch of the tower supplied by Tim Malone, Kentucky registered professional engineer.

Enclosed as Exhibit 12 is a list of utilities, corporations, or persons with whom the tower is likely to compete.

[THE REMAINDER OF THIS PAGE INTENTIONALLY LEFT BLANK.]

WHEREFORE, Applicant, having met the requirements of KRS 278.020(1), 278.650, 278.665, and all applicable rules and regulations of the PSC, respectfully requests that the PSC accept the foregoing Application for filing and grant a Certificate of Public Convenience and Necessity to construct and operate the proposed tower.

The foregoing document was prepared by Krystal Branham, Regulatory Compliance Attorney for East Kentucky Network, LLC d/b/a Appalachian Wireless. All related questions or correspondence concerning this filing should be mailed to East Kentucky Network, LLC d/b/a Appalachian Wireless, 101 Technology Trail, Ivel, KY 41642.

SUBMITTED BY: Raina Helton DATE: 4/10/24
Raina Helton, Regulatory Compliance Director

APPROVED BY: Michael L. Johnson DATE: 4-10-2024
Michael L. Johnson, CEO

ATTORNEY: Krystal Branham DATE: 4/10/24
Hon. Krystal Branham, Attorney

CONTACT INFORMATION:

Michael L. Johnson, CEO
Phone: (606) 477-2355, Ext. 1212
Email: mjohnson@ekn.com

Raina Helton, Regulatory Compliance Director
Phone: (606) 477-2355, Ext. 1005
Email: rhelton@ekn.com

Krystal Branham, Attorney
Phone: (606) 477-2355, Ext. 1009
Email: kbranham@ekn.com

Mailing Address:

**East Kentucky Network, LLC
d/b/a Appalachian Wireless
101 Technology Trail
Ivel, KY 41642**

1	
2	
3	
4	
5	
6	
7	
8	
9	
10	
11	
12	
13	
14	
15	

Exhibit 1

ULS License

Cellular License - KNKN880 - East Kentucky Network, LLC d/b/a Appalachian Wireless

Call Sign	KNKN880	Radio Service	CL - Cellular
Status	Active	Auth Type	Regular

Market

Market	CMA451 - Kentucky 9 - Elliott	Channel Block	B
Submarket	0	Phase	2

Dates

Grant	10/26/2021	Expiration	10/01/2031
Effective	10/26/2021	Cancellation	

Five Year Buildout Date

10/23/1996

Control Points

1 U.S. 23, HAROLD, KY

Licensee

FRN	0001786607	Type	Limited Liability Company
-----	------------	------	---------------------------

Licensee

East Kentucky Network, LLC d/b/a Appalachian Wireless 101 Technology Trail Ivel, KY 41642 ATTN Regulatory Compliance Department	P:(606)477-2355 E:compliance@ekn.com
------------------------------------------------------------------------------------------------------------------------------------------	-----------------------------------------

Contact

East Kentucky Network, LLC Cindy D McCarty Esq P.O. Box 41642-9057 101 Technology Trl Ivel, KY 41642 ATTN Regulatory Compliance Dept.	P:(606)477-2355 E:cmccarty@ekn.com
------------------------------------------------------------------------------------------------------------------------------------------------------	---------------------------------------

Ownership and Qualifications

Radio Service Type	Mobile		
Regulatory Status	Common Carrier	Interconnected	Yes

Alien Ownership

The Applicant answered "No" to each of the Alien Ownership questions.

Basic Qualifications

The Applicant answered "No" to each of the Basic Qualification questions.

Demographics

Race

Ethnicity

Gender



Exhibit 2

EXHIBIT 2 – LIST OF PROPERTY OWNERS

Statement Pursuant to Section 1 (1) (I) 807 KAR 5:063

Section 1 (1)(I) 1. The following is a list of every property owner who according to property valuation administrator's records, owns property within 500 feet of the proposed tower and each have been: notified by certified mail, return receipt requested, of the proposed construction,

Section 1 (1)(I) 2. Every person listed below who, according to the property valuation administrator's records, owns property within 500 feet of the proposed tower has been: Given the Commission docket number under which the application will be processed: and

Section 1 (1)(I) 3. Every person listed below who, according to property valuation administrator's records owns property within 500 feet of the proposed tower has been: Informed of his right to request intervention.

Section 2. If the construction is proposed for an area outside the incorporated boundaries of a city, the application shall state that public notices required by Section 1(1)(L) have been sent to every person who, according to the property valuation administrator, owns property contiguous to the property upon which the construction is proposed

LIST OF PROPERTY OWNERS

Morgan County School District Finance Corp.
PO Box 489
West Liberty, KY 41472

Commonwealth of Kentucky
KYDOT District 10
473 KY Route 15
Jackson, KY 41339

Darrell Patrick
93 Highway 1002
West Liberty, KY 41472

David and Lynn Phipps
5429 Hwy 191
West Liberty, KY 41472

Robert and Dorothy Caskey
4362 Filly Lane
Destin, FL 32541

Jerry Whitt
7977 Hwy 7
West Liberty, KY 41472



VIA: U.S. CERTIFIED MAIL

PUBLIC NOTICE

April 10, 2024

Morgan County School District Finance Corp.
PO Box 489
West Liberty, KY 41472

RE: Public Notice-Public Service Commission of Kentucky (Case No. 2024-00089)

East Kentucky Network, LLC d/b/a Appalachian Wireless has applied to the Public Service Commission of Kentucky for a Certificate of Public Convenience and Necessity to construct and operate a new facility to provide cellular telecommunications service in Morgan County. The facility will include a 190-foot self-supporting tower with attached antennas extending upwards, and an equipment shelter located on a tract of land near 7485 Route 7, West Liberty, Kentucky. A map showing the location of the proposed new facility is enclosed. This notice is being sent to you because you may own property within a 500' radius of the proposed tower or own property contiguous to the property upon which construction is proposed.

The Commission invites your comments regarding the proposed construction. You also have the right to intervene in this matter. The Commission must receive your initial communication within 20 days of the date of this letter as shown above.

Your comments and request for intervention should be addressed to: Executive Director's Office, Public Service Commission of Kentucky, P.O. Box 615, Frankfort, KY 40602. Please refer to Case No. 2024-00089 in your correspondence.

If you have any questions for East Kentucky Network, LLC, please direct them to my attention at the following address: East Kentucky Network, LLC, 101 Technology Trail, Ivel, KY 41642 or call me at 606-477-2355, Ext. 1005.

Sincerely,

A handwritten signature in blue ink that reads "Raina Helton".

Raina Helton, CKP
Regulatory Compliance Director
Enclosure 1



VIA: U.S. CERTIFIED MAIL

PUBLIC NOTICE

April 10, 2024

Commonwealth of Kentucky
KYDOT District 10
473 KY Route 15
Jackson, KY 41339

RE: Public Notice-Public Service Commission of Kentucky (Case No. 2024-00089)

East Kentucky Network, LLC d/b/a Appalachian Wireless has applied to the Public Service Commission of Kentucky for a Certificate of Public Convenience and Necessity to construct and operate a new facility to provide cellular telecommunications service in Morgan County. The facility will include a 190-foot self-supporting tower with attached antennas extending upwards, and an equipment shelter located on a tract of land near 7485 Route 7, West Liberty, Kentucky. A map showing the location of the proposed new facility is enclosed. This notice is being sent to you because you may own property within a 500' radius of the proposed tower or own property contiguous to the property upon which construction is proposed.

The Commission invites your comments regarding the proposed construction. You also have the right to intervene in this matter. The Commission must receive your initial communication within 20 days of the date of this letter as shown above.

Your comments and request for intervention should be addressed to: Executive Director's Office, Public Service Commission of Kentucky, P.O. Box 615, Frankfort, KY 40602. Please refer to Case No. 2024-00089 in your correspondence.

If you have any questions for East Kentucky Network, LLC, please direct them to my attention at the following address: East Kentucky Network, LLC, 101 Technology Trail, Ivel, KY 41642 or call me at 606-477-2355, Ext. 1005.

Sincerely,

A handwritten signature in blue ink that reads "Raina Helton".

Raina Helton, CKP
Regulatory Compliance Director
Enclosure 1



VIA: U.S. CERTIFIED MAIL

PUBLIC NOTICE

April 10, 2024

Darrell Patrick
93 Highway 1002
West Liberty, KY 41472

RE: Public Notice-Public Service Commission of Kentucky (Case No. 2024-00089)

East Kentucky Network, LLC d/b/a Appalachian Wireless has applied to the Public Service Commission of Kentucky for a Certificate of Public Convenience and Necessity to construct and operate a new facility to provide cellular telecommunications service in Morgan County. The facility will include a 190-foot self-supporting tower with attached antennas extending upwards, and an equipment shelter located on a tract of land near 7485 Route 7, West Liberty, Kentucky. A map showing the location of the proposed new facility is enclosed. This notice is being sent to you because you may own property within a 500' radius of the proposed tower or own property contiguous to the property upon which construction is proposed.

The Commission invites your comments regarding the proposed construction. You also have the right to intervene in this matter. The Commission must receive your initial communication within 20 days of the date of this letter as shown above.

Your comments and request for intervention should be addressed to: Executive Director's Office, Public Service Commission of Kentucky, P.O. Box 615, Frankfort, KY 40602. Please refer to Case No. 2024-00089 in your correspondence.

If you have any questions for East Kentucky Network, LLC, please direct them to my attention at the following address: East Kentucky Network, LLC, 101 Technology Trail, Ivel, KY 41642 or call me at 606-477-2355, Ext. 1005.

Sincerely,

A handwritten signature in blue ink that reads "Raina Helton".

Raina Helton, CKP
Regulatory Compliance Director
Enclosure 1



VIA: U.S. CERTIFIED MAIL

PUBLIC NOTICE

April 10, 2024

David and Lynn Phipps
5429 Hwy 191
West Liberty, KY 41472

RE: Public Notice-Public Service Commission of Kentucky (Case No. 2024-00089)

East Kentucky Network, LLC d/b/a Appalachian Wireless has applied to the Public Service Commission of Kentucky for a Certificate of Public Convenience and Necessity to construct and operate a new facility to provide cellular telecommunications service in Morgan County. The facility will include a 190-foot self-supporting tower with attached antennas extending upwards, and an equipment shelter located on a tract of land near 7485 Route 7, West Liberty, Kentucky. A map showing the location of the proposed new facility is enclosed. This notice is being sent to you because you may own property within a 500' radius of the proposed tower or own property contiguous to the property upon which construction is proposed.

The Commission invites your comments regarding the proposed construction. You also have the right to intervene in this matter. The Commission must receive your initial communication within 20 days of the date of this letter as shown above.

Your comments and request for intervention should be addressed to: Executive Director's Office, Public Service Commission of Kentucky, P.O. Box 615, Frankfort, KY 40602. Please refer to Case No. 2024-00089 in your correspondence.

If you have any questions for East Kentucky Network, LLC, please direct them to my attention at the following address: East Kentucky Network, LLC, 101 Technology Trail, Ivel, KY 41642 or call me at 606-477-2355, Ext. 1005.

Sincerely,

A handwritten signature in blue ink that reads "Raina Helton".

Raina Helton, CKP
Regulatory Compliance Director
Enclosure 1



VIA: U.S. CERTIFIED MAIL

PUBLIC NOTICE

April 10, 2024

Robert and Dorothy Caskey
4362 Filly Lane
Destin, FL 32541

RE: Public Notice-Public Service Commission of Kentucky (Case No. 2024-00089)

East Kentucky Network, LLC d/b/a Appalachian Wireless has applied to the Public Service Commission of Kentucky for a Certificate of Public Convenience and Necessity to construct and operate a new facility to provide cellular telecommunications service in Morgan County. The facility will include a 190-foot self-supporting tower with attached antennas extending upwards, and an equipment shelter located on a tract of land near 7485 Route 7, West Liberty, Kentucky. A map showing the location of the proposed new facility is enclosed. This notice is being sent to you because you may own property within a 500' radius of the proposed tower or own property contiguous to the property upon which construction is proposed.

The Commission invites your comments regarding the proposed construction. You also have the right to intervene in this matter. The Commission must receive your initial communication within 20 days of the date of this letter as shown above.

Your comments and request for intervention should be addressed to: Executive Director's Office, Public Service Commission of Kentucky, P.O. Box 615, Frankfort, KY 40602. Please refer to Case No. 2024-00089 in your correspondence.

If you have any questions for East Kentucky Network, LLC, please direct them to my attention at the following address: East Kentucky Network, LLC, 101 Technology Trail, Ivel, KY 41642 or call me at 606-477-2355, Ext. 1005.

Sincerely,

A handwritten signature in blue ink that reads "Raina Helton".

Raina Helton, CKP
Regulatory Compliance Director
Enclosure 1



VIA: U.S. CERTIFIED MAIL

PUBLIC NOTICE

April 10, 2024

Jerry Whitt
7977 Hwy 7
West Liberty, KY 41472

RE: Public Notice-Public Service Commission of Kentucky (Case No. 2024-00089)

East Kentucky Network, LLC d/b/a Appalachian Wireless has applied to the Public Service Commission of Kentucky for a Certificate of Public Convenience and Necessity to construct and operate a new facility to provide cellular telecommunications service in Morgan County. The facility will include a 190-foot self-supporting tower with attached antennas extending upwards, and an equipment shelter located on a tract of land near 7485 Route 7, West Liberty, Kentucky. A map showing the location of the proposed new facility is enclosed. This notice is being sent to you because you may own property within a 500' radius of the proposed tower or own property contiguous to the property upon which construction is proposed.

The Commission invites your comments regarding the proposed construction. You also have the right to intervene in this matter. The Commission must receive your initial communication within 20 days of the date of this letter as shown above.

Your comments and request for intervention should be addressed to: Executive Director's Office, Public Service Commission of Kentucky, P.O. Box 615, Frankfort, KY 40602. Please refer to Case No. 2024-00089 in your correspondence.

If you have any questions for East Kentucky Network, LLC, please direct them to my attention at the following address: East Kentucky Network, LLC, 101 Technology Trail, Ivel, KY 41642 or call me at 606-477-2355, Ext. 1005.

Sincerely,

A handwritten signature in blue ink that reads "Raina Helton".

Raina Helton, CKP
Regulatory Compliance Director
Enclosure 1

Pomp

Location:

7485 Route 7
West Liberty, KY 41472

Coordinates:

Lat: 38°00'03.04"N
Lon: 83°16'37.78"W



Exhibit 3



VIA: U.S. CERTIFIED MAIL

April 10, 2024

Jim Gazay, Morgan County Judge Executive
450 Prestonsburg Street
West Liberty, KY 41472

RE: Public Notice-Public Service Commission of Kentucky (Case No. 2024-00089)

East Kentucky Network, LLC d/b/a Appalachian Wireless has applied to the Public Service Commission of Kentucky for a Certificate of Public Convenience and Necessity to construct and operate a new facility to provide cellular telecommunications service in Morgan County. The facility will include a 190-foot self-supporting tower with attached antennas extending upwards, and an equipment shelter located on a tract of land near 7485 Route 7, West Liberty, Morgan County, Kentucky. A map showing the location of the proposed new facility is enclosed. This notice is being sent to you because you are the County Judge Executive of Morgan County.

The Commission invites your comments regarding the proposed construction. You also have the right to intervene in this matter. The Commission must receive your initial communication within 20 days of the date of this letter as shown above.

Your comments and request for intervention should be addressed to: Executive Director's Office, Public Service Commission of Kentucky, P.O. Box 615, Frankfort, KY 40602. Please refer to Case No. 2024-00089 in your correspondence.

If you have any questions for East Kentucky Network, LLC, please direct them to my attention at the following address: East Kentucky Network, LLC, 101 Technology Trail, Ivel, KY 41642 or call me at 606-477-2355, Ext. 1005.

Sincerely,

A handwritten signature in blue ink that reads "Raina Helton".

Raina Helton, CKP
Regulatory Compliance Director
Enclosure

Pomp

Location:

7485 Route 7
West Liberty, KY 41472

Coordinates:

Lat: 38°00'03.04"N
Lon: 83°16'37.78"W



dba Appalachian Wireless
101 Technology Trail
Ivel, KY 41642
Phone: 606-477-2355
Fax: 606-791-2225

EAST KENTUCKY
NETWORK



To: The Licking Valley Courier
Attn: Classifieds

From: Libby Ratliff
Regulatory Compliance Coordinator

Email: courier@mrtc.com

Date: April 5, 2024

Re: PUBLIC NOTICE ADVERTISEMENT

Pages: 1

Please place the following Public Notice Advertisement in The Licking Valley Courier to be ran on April 11, 2024.

PUBLIC NOTICE:

RE: Public Service Commission of Kentucky (CASE NO. 2024-00089)

Public Notice is hereby given that East Kentucky Network, LLC, dba Appalachian Wireless has applied to the Kentucky Public Service Commission to construct a cellular telecommunications tower on a tract of land located at 7485 Route 7, West Liberty, Morgan County, Kentucky. The proposed tower will be a 190-foot self-supporting tower with attached antennas. If you would like to respond to this notice, please contact the Executive Director, Public Service Commission, 211 Sower Boulevard, PO Box 615, Frankfort, Kentucky 40602. Please refer to Case No. 2024-00089.

If you have any questions about the placement of the above-mentioned notice, please call me at 606-477-2375, ext. 1005.

Thank you,

Raina Helton
Regulatory Compliance Director

The message above and the information contained in the documents transmitted are confidential and intended only for the person(s) named above. Dissemination, distribution or copying of this communication by anyone other than the person(s) named above is prohibited. If you have received this communication in error, please notify us immediately by telephone and return the original message to us at the address listed above via regular mail. Thank you.

Exhibit 4

**Geotechnical Investigation Report
Appalachian Wireless Wrigley Tower
Morgan County, Kentucky**

Project No.
APS230057

July 24, 2023

Prepared for:



Prepared by:



July 24, 2023

Mr. Stanton Neece
Appalachian Wireless
Cellular Manager
E: sneece@ekn.com
P: 606-794-5254

**Subject: Geotechnical Investigation Report
Appalachian Wireless Wrigley Tower
Morgan County, Kentucky**

This report presents the results, findings, and recommendations of a geotechnical exploration conducted by Anderson Professional Services, LLC (APS GEO) in response to a request by Appalachian Wireless for geotechnical drilling, laboratory testing, and engineering services at the proposed Appalachian Wireless Wrigley Tower Site off Kentucky Highway 7, in Morgan County, Kentucky. The results of these tasks are presented in this report. Our work was completed in general accordance with our Master Service Agreement dated May 24, 2023.

This report was prepared by engineering staff working under the direct supervision and review of a licensed professional civil engineer specializing in geotechnical engineering and registered in the state of Kentucky. The findings, conclusions, and recommendations presented herein are based on the applicable standards of the profession at the time this report was prepared and within this geographic area. This report has been prepared for the exclusive use of the Owner for specific application to the proposed project, in accordance with generally accepted geotechnical and foundation engineering practices.

If you have any questions regarding this report or need any additional information, please do not hesitate to contact us.

Best Regards,

Justin Anderson, PE

President
Justin Anderson, PE
Justin.Anderson@apsgeo.com
c: 859.583.0732

Ryan Johnson, PLS

Project Manager
Ryan Johnson, PLS
Ryan.Johnson@apsgeo.com
c: 606.794.0987





Table of Contents

Table of Contents.....	i
1 Project Description and Understanding	1
2 Site Geology and Geologic Hazards	2
2.1 Physiographic Region	2
2.2 USGS Geologic Survey Map.....	3
2.3 Karst Potential.....	3
2.4 Regional Seismicity.....	3
3 Subsurface Investigation	3
4 Laboratory Testing.....	4
5 Subsurface Conditions.....	5
5.1 Surficial Soils.....	5
5.2 Bedrock.....	5
5.3 Groundwater	5
6 Engineering Analyses and Preliminary Design Recommendations	5
6.1 Foundation Selection.....	5
6.2 Design Soil Strength Parameters.....	5
6.3 Spread Footing on Bedrock.....	6
6.4 Seismic Design Considerations.....	6
7 Limitations	7
8 References.....	7
APPENDIX A: Geotechnical Field Exploration and Laboratory Test Results	9
APPENDIX B: Preliminary Construction Recommendations.....	12
APPENDIX C: Limitations and Information about this Report.....	13

1 Project Description and Understanding

APS GEO understands that Appalachian Wireless is planning to construct a new cellular antenna tower off Kentucky Highway 7 in Morgan County, Kentucky, near GPS point: 38.000843, -83.277162. The intent of this study is to perform a geotechnical exploration in the vicinity of the proposed tower location and to provide a geotechnical engineering report with foundation design recommendations that Appalachian Wireless may use in the tower structure design. The location of the proposed tower foundation is in Morgan County, Kentucky as shown in Figures 1 and 2.

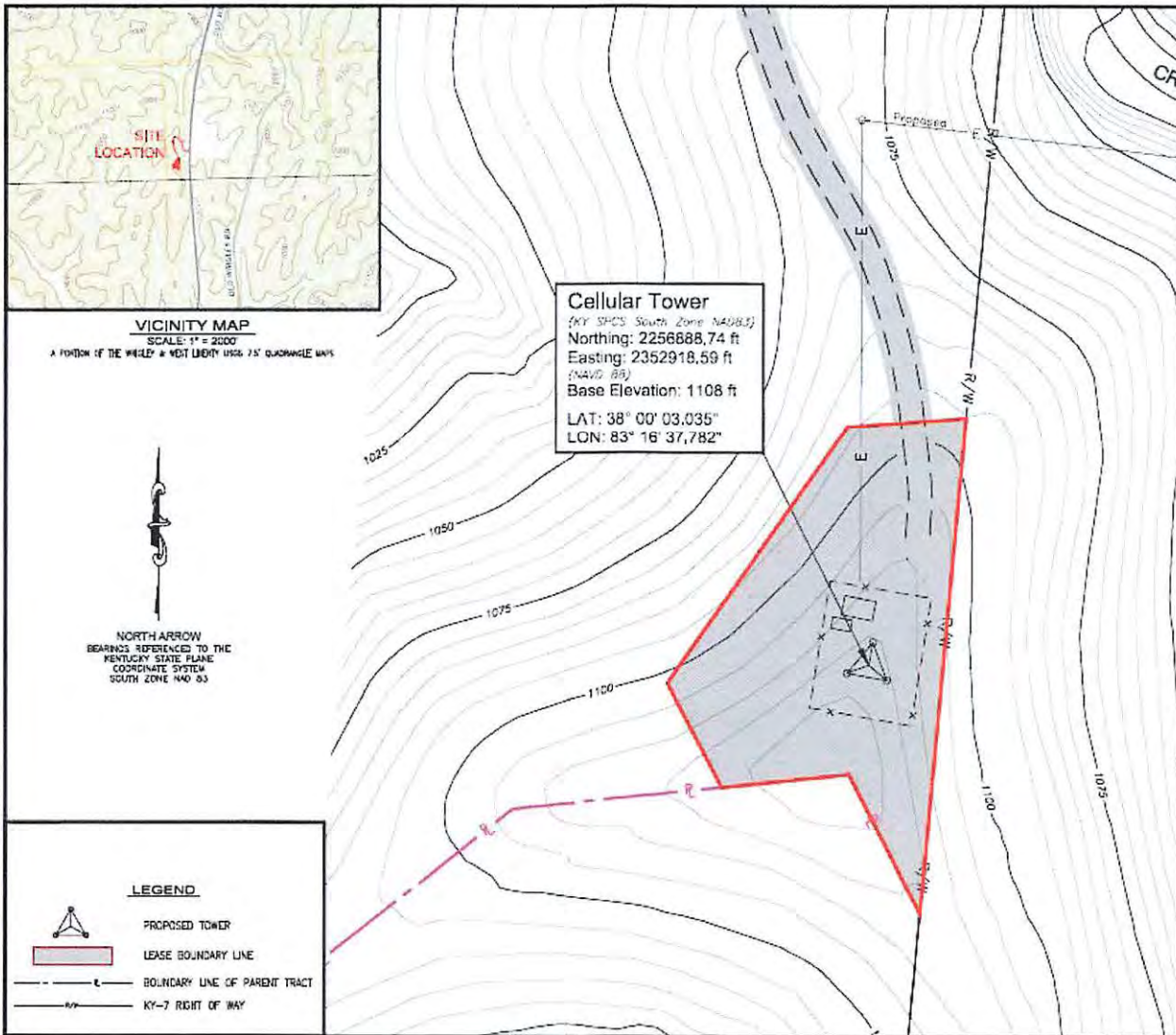

Figure 1 – Proposed Antenna Location and Configuration

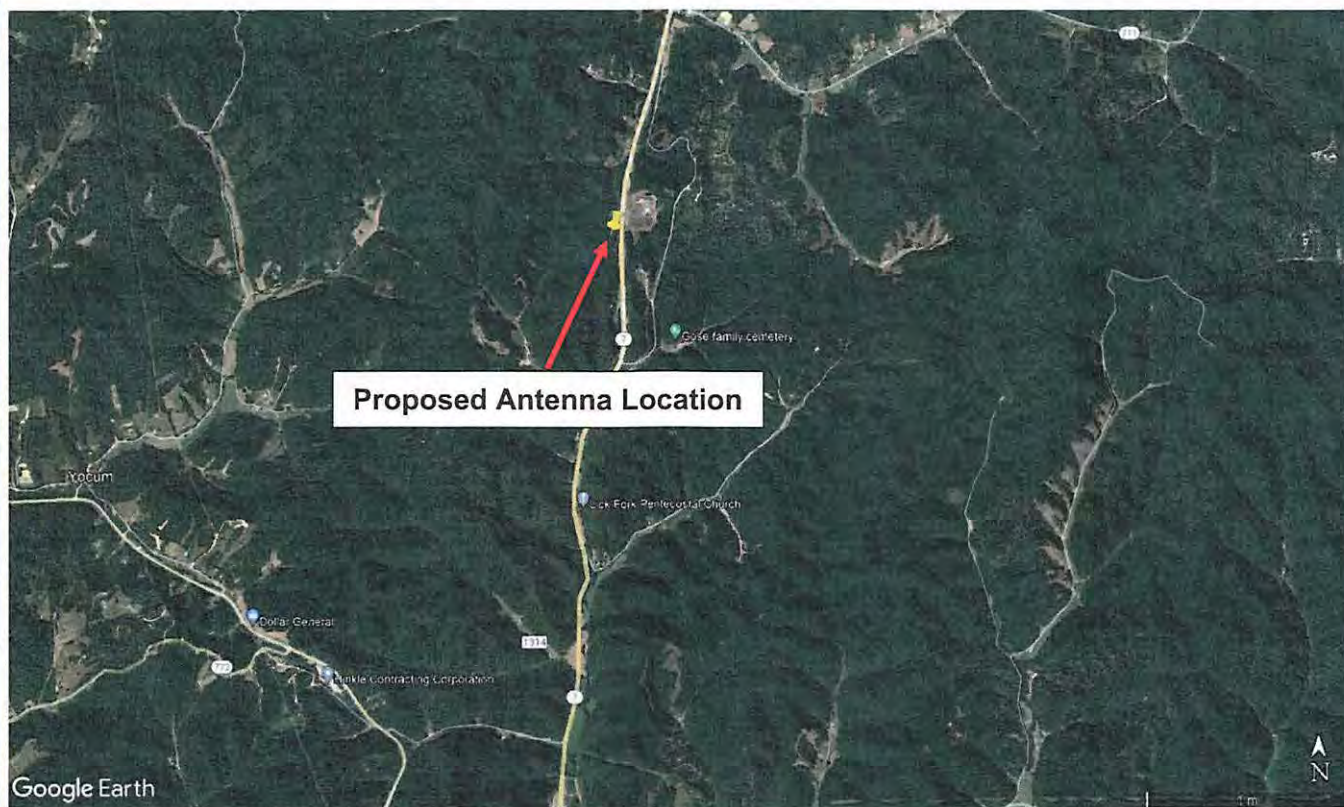

Figure 2 – Site Location Map

2 Site Geology and Geologic Hazards

2.1 Physiographic Region

The project site is situated within the Cumberland Plateau Physiographic Region of Kentucky. The Cumberland Plateau is an area of intricately dissected rocks of Pennsylvanian age in eastern Kentucky. It is bounded on the western edge by the Pottsville (or Cumberland) Escarpment formed by resistant beds of sandstone and conglomerate in the lower part of the Pennsylvanian strata. Within the Cumberland Plateau, wooded mountain crests extend to the horizon in all directions. The mountain slopes are carved by ravines eroded through thick, flat-lying sequences of (Pennsylvanian age) coal-bearing elastic rocks. The ravines are tributary to sinuous, narrow valley bottoms which wind between steep valley walls. The major drainage pattern is dendritic. Major rivers, including the Big Sandy, Licking, Kentucky, and Cumberland, meander through the mountains. Locally, their valleys widen to a mile or more; most of the human habitation is on the flood plains and low terraces. High terraces such as those associated with high-level fluvial deposits along the Kentucky River are remnants of earlier valley bottoms.

Generally, the knife-edge crests of the mountains are as narrow and sinuous as the valley bottoms. Flatlands on either the ridgetops or the valley bottoms are commonly of small extent. Most of the terrain is in steep slopes. Whether the local topographic relief of this region spans as little as 200 ft or exceeds 2,000 ft, the landforms are similar. The mountain slopes underlain by shale and sandstone are mantled by complex accumulations of rock fragments and weathered debris (colluvium) that move downslope by debris avalanche, landslide, creep, and sheet wash. Deeply weathered soils are uncommon and occur on isolated, nearly level ridge crests and high-level terrace deposits. Cliffs of resistant sandstone cap

many ridges and spurs. Scenic erosion remnants include pinnacles or "chimneys," shallow eaves known as "rock houses," and arches or natural bridges. (Newell, 2023)

2.2 USGS Geologic Survey Map

A review of the United States Geological Survey (USGS) Geologic Map of the Wrigley Quadrangle, Southeastern Kentucky (Hosterman et al., 1961) indicates that the terrain near the site is underlain by relatively thin layers of overburden soil and residual deposits over bedrock of the Lee Formation. The primary bedrock lithology consists of sandstone, shale, and limestone, siltstone with generalized descriptions as follows:

Quartzose sandstone massive crossbedded, about 200 feet thick, contains a few beds and lenses of dark gray shale and thin quartz conglomerate stringers which form prominent cliffs; unconformity at base locally truncates the underlying shale facies, the seven upper Mississippian formations, and the uppermost part of the Brodhead formation. Shale, dark gray, about 80 feet thick interfingering with siltstone, clayey sandstone, quartzose sandstone, thin coal beds and plastic underclays.

Limestone, part of the Pennington and Golconda formation equivalents, about 80 feet thick, massive, very fine crystalline to dense, contains abundant chert nodules and few marine fossils, heavily brecciated and bedding is complexly involute and contorted. Siltstone, part of Brodhead formation, very greenish-gray, resistant, with sandstone, irregularly interbedded with minor amounts of thin green shale that weathers greenish brown, much of siltstone has no planes of weakness along bedding; locally the uppermost bed is a calcareous siltstone approximately 1 to 2 feet thick that weathers yellowish brown (Floyds Knob formation of Stockdale, 1939).

2.3 Karst Potential

The Kentucky Geological Survey (KGS) maps the karst potential at the site as Non-Karst. KGS defines Non-Karst as areas underlain by bedrock with limited or no potential for karst development. Karst features are rare or absent.

2.4 Regional Seismicity

No potentially active Quaternary faults or seismic zones have been identified within approximately 50 miles of the project site (USGS, 2023). Seismic hazards for Morgan County, KY are identified as relatively low by USGS.

Earthquakes have periodically occurred in and around Kentucky throughout recorded history. The most widely felt and damaging earthquakes in the state occurred in the winter of 1811-1812 and were centered in northeastern Arkansas, northwestern Tennessee, southwestern Kentucky, and southeastern Missouri—the New Madrid Seismic Zone. The 1811-1812 earthquakes are reported to have caused damage (i.e. modified Mercalli intensity VII-IX) throughout much of the commonwealth. The 1980 Sharpsburg earthquake caused significant damage (MMI VII) in Maysville, KY. Since earthquakes are not well understood in the central United States it is very difficult to predict them. Still, they occur in and around Kentucky and can impact infrastructure around the region (Kentucky Transportation Center).

3 Subsurface Investigation

The subsurface investigation for the project consisted of one (1) exploratory test boring, referred to herein as Boring B-1. The approximate location of the boring is shown on the Boring Plan included as Figure 3 below.

The boring was advanced with a truck-mounted, rotary Mobile Drill B53 drill rig equipped with 6-inch OD hollow-stem augers or casing advancer, as appropriate. Each of the soundings and the boring were advanced to bedrock, with Standard Penetration Test (SPT) samples being obtained in the overburden at Boring B-1 at 2.5 to 5-foot intervals. The bedrock was then cored in Boring B-1. A summary of the boring results is included in Table 1.

Table 1 – Summary of Boring Results

Boring	Latitude	Longitude	Surface Elevation ¹ (ft.)	Top of Bedrock Depth (ft.) / Elevation (ft.)	Bottom of Boring Depth (ft.) / Elevation (ft.)
B-1	38.001454°	-83.277033°	1080	4 / 1076	24.4 / 1055.6

NOTE: 1 – Elevations from topography mapping estimated based on Google Earth.



Figure 3 – Boring Location Map

4 Laboratory Testing

The soil and bedrock samples were returned to our soil mechanics laboratory where they were reviewed for consistency and visual classification by APS GEO engineering personnel. No additional laboratory testing was performed to supplement the visual review.

Final test boring logs are included in Appendix A and include the results of the field exploration, the engineering review of the samples, and the laboratory test results. The laboratory test results are briefly summarized in the following sections, presented on the boring logs, and summarized in Appendix A.

5 Subsurface Conditions

This section provides a summary of the soil and bedrock types encountered in the borings.

5.1 Surficial Soils

Surficial soils were encountered the boring to a depth of 4 feet below the ground surface. The soil consisted of dense clayey sand with one SPT N-value of 38 blows per foot (bpf).

5.2 Bedrock

The bedrock at the site consists of shale and siltstone. The shale portion of the bedrock was orange-brown to gray in color, judged to be weak in strength, and in beds ranging in thickness from less than 1/4 inch to 6 inches. The siltstone was gray in color, judged to be strong in strength, and in beds ranging in thickness from less than 1/4 inch to 1/2 inch. Recovery of the cored bedrock in Boring B-1 ranged from 72 to 100 percent. In Boring B-1, RQD's ranged from 0 to 12 percent. Photographs of the rock core are included in Appendix A.

5.3 Groundwater

Groundwater was not encountered during drilling. However, it should be noted that fluctuations in groundwater levels may occur due to seasonal variations in the local and regional precipitation, in the level of the adjacent rivers and streams, and other factors not evident at the time of measurement.

6 Engineering Analyses and Preliminary Design Recommendations

Geotechnical engineering design recommendations are provided in the following sections, which include proposed design parameters, allowable bearing capacity, and discussion of potential settlement.

6.1 Foundation Selection

Based on discussions with Appalachian Wireless, we understand that either a spread footing or direct burial foundation types are generally preferred for this application. Given the presence of shallow bedrock at the site the use of spread footings bearing directly onto competent bedrock is recommended at this site.

6.2 Design Soil Strength Parameters

The design shear strength parameters listed in Table 2 were developed for the project based on general published ranges for similar material and our general experience.

Table 2 – Summary of Design Shear Strength Parameters

Material	Unit Weight	Short-Term Strengths		Long-Term Strengths	
	γ_{total} (pcf)	c (ksf)	Φ (degrees)	c' (ksf)	Φ' (psf)
Clayey Sand	120	0	28	0	28
Shale/Siltstone	135	250	-	500	35

6.3 Spread Footing on Bedrock

Bearing capacity of a spread footing support on fill was evaluated assuming a minimum depth adequate embedment to provide frost protection. According to Kentucky Building Code 2018 Table 1809.5, for the project site, in Knott County, KY, the minimum depth for frost line protection is 33 inches below surface elevation. However, due to the shallow nature of the bedrock, we recommend extending the footing to the top of competent bedrock.

An ultimate bearing capacity was calculated using Terzaghi's ultimate bearing capacity equation for a strip load, applying a conservative estimated cohesion of 250 kips per square foot (ksf) for the shale bedrock. The cohesion was estimated from a combination of the SPT test results, pocket penetrometer test results, and the engineer's review of the samples in the laboratory. Based on this, applying a factor of safety of 3.0, and applying our engineering judgement, it is our professional opinion that the competent shale/siltstone formation at this site is suitable for a maximum allowable bearing capacity of 30 ksf.

The allowable bearing capacity recommendations indicated above are based on proper subgrade preparation and footing installation during construction. The contractor should compact leveling material directly below the footings in place prior to placement of steel and concrete. More detailed construction recommendations are discussed below.

For footings constructed on competent bedrock, the resulting settlement will be negligible.

We recommend that APS GEO personnel inspect the footing prior to pouring to check with consistency with our recommendations.

6.4 Seismic Design Considerations

The seismic design procedures outlined in the AASHTO LRFD Bridge Design Specifications indicate that structural design loads are to be based on site class definitions determined by the shear wave velocity, average SPT N-values, and/or average undrained shear strength for the upper 100 feet of the subsurface profile. Based on the results of the exploration and the geology of the area, we recommend that Site Class C be used for design purposes at the site.

The ASCE 7-22 provides guidelines for assessing seismic hazards. The seismic hazard is characterized by the acceleration response spectrum and the site factors associated with the relevant site coefficient. A summary of the seismic data parameters determined from the ASCE 7 Hazard Tool is provided in Table 6 below.

Table 6 – Summary of Seismic Data

Description	Data
Site Soil Class	C
Risk Level	III
Seismic Design Category	B
S_s	0.27
S_1	0.088
S_{Ms}	0.27
S_{M1}	0.12
S_{Ds}	0.18
S_{D1}	0.077
T_L	12
PGA_M	0.14
V_{s30}	530

Source: USGS Seismic Design Maps based on ASCE/SEI 7-22 and ASCE/SEI 7-22 Table 1.5-2. Additional data for site-specific ground motion procedures in accordance with ASCE/SEI 7-22 Ch. 21 are available from USGS.

7 Limitations

This report presents the geotechnical results, findings, and recommendations in response to a request by Appalachian Wireless for the Wrigley Tower Project, Morgan County, Kentucky. It has been prepared in accordance with generally accepted engineering practice and in a manner consistent with the level of care and skill for this type of project within this geographic area. No warranty, expressed or implied, is made.

The preliminary conclusions and recommendations presented herein are based on field reconnaissance, research, and available literature. Geotechnical engineering and the geologic sciences are characterized by uncertainty. Professional judgments presented herein are based partly on our understanding of the proposed construction, partly on our general experience, and on the state-of-the-practice at the time of this writing.

The subsurface conditions described in this report are based on limited exploration data collected at widely spaced boring locations, site reconnaissance, information from the client, and our own professional judgment based on experience with similar sites and soil conditions. The boring logs attached to this report depict only the conditions at the actual boring locations at the time of drilling. Subsurface conditions are variable between boring locations and the actual conditions between exploration locations may only become evident during construction. Groundwater levels will vary with time, precipitation, and changes to water levels in the adjacent creek. APS GEO is not responsible for others' interpretation of the data presented in this report or the use of this report by others for the project. Please refer to Appendix C.

8 References

- AASHTO LRFD Bridge Design Specifications (2019).
- AASHTO Standard Specifications for Transportation Materials and Methods of Sampling and Testing (2022).

American Society of Civil Engineers, 4/15/2023, ASCE 7 Hazard Tool, referenced online at: <https://asce7hazardtool.online/>

Ensoft (2022) A program for the Analysis of Deep Foundations Under Lateral Loading, by Wang, Vasquez, Arrellaga, and Isenhower, dated February 2022.

Kentucky Department of Housing, Buildings and Construction, 2018 Kentucky Building Code, Third Edition, August 2022.

Kentucky Geological Survey, Geology of Kentucky, Physiographic Map of Kentucky, referenced online at: Cumberland Plateau Region, Kentucky Geological Survey site (uky.edu)

Kentucky Transportation Center Research Report KTC-07-07/SPR246-02-6F.

NCHRP (2008) "Seismic Analysis and Design of Retaining Walls, Buried Structures, Slopes, and Embankments," National Cooperative Highway Research Program (NCHRP), 2008.

The Geology of Kentucky, A Text to Accompany the Geologic Map of Kentucky, US Geological Survey Professional Paper 1151-H, Online Version 1.0 (McDowell, Robert, 2001):

United States Geological Survey (USGS) Geologic Map of the Kite Quadrangle, Southeastern, Kentucky (Hinrichs, E. and Rice, C., 1976).

United States Geological Survey (USGS), 6/24/2023, Contributions to the Geology of Kentucky, Physiography by Wayne L. Newell, referenced online at: <https://pubs.usgs.gov/pp/p1151h/physiography.html>

APPENDIX A: Geotechnical Field Exploration and Laboratory Test Results

All soils were visually classified or confirmed per the Unified Soil Classification System (USCS). The following is a summary of this methodology.

UNIFIED SOIL CLASSIFICATION AND SYMBOL CHART		
COARSE-GRAINED SOILS (more than 50% of material is larger than No. 200 sieve size)		
GRAVELS More than 50% of coarse fraction larger than No. 4 sieve size	Clean Gravels (Less than 5% fines)	
	GW	Well-graded gravels, gravel-sand mixtures, little or no fines
	GP	Poorly-graded gravels, gravel-sand mixtures, little or no fines
	Gravels with fines (More than 12% fines)	
	GM	Silty gravels, gravel-sand-silt mixtures
	GC	Clayey gravels, gravel-sand-clay mixtures
SANDS 50% or more of coarse fraction smaller than No. 4 sieve size	Clean Sands (Less than 5% fines)	
	SW	Well-graded sands, gravelly sands, little or no fines
	SP	Poorly graded sands, gravelly sands, little or no fines
	Sands with fines (More than 12% fines)	
	SM	Silty sands, sand-silt mixtures
	SC	Clayey sands, sand-clay mixtures
FINE-GRAINED SOILS (50% or more of material is smaller than No. 200 sieve size)		
SILTS AND CLAYS Liquid limit less than 50%	ML	Inorganic silts and very fine sands, rock flour, silty of clayey fine sands or clayey silts with slight plasticity
	CL	Inorganic clays of low to medium plasticity, gravelly clays, sandy clays, silty clays, lean clays
	OL	Organic silts and organic silty clays of low plasticity
SILTS AND CLAYS Liquid limit 50% or greater	MH	Inorganic silts, micaceous or diatomaceous fine sandy or silty soils, elastic silts
	CH	Inorganic clays of high plasticity, fat clays
	OH	Organic clays of medium to high plasticity, organic silts
HIGHLY ORGANIC SOILS	PT	Peat and other highly organic soils

LABORATORY CLASSIFICATION CRITERIA		
GW	$C_u = \frac{D_{60}}{D_{10}}$ greater than 4; $C_c = \frac{D_{30}}{D_{10} \times D_{60}}$ between 1 and 3	
GP	Not meeting all gradation requirements for GW	
GM	Atterberg limits below "A" line or P.I. less than 4	Above "A" line with P.I. between 4 and 7 are borderline cases requiring use of dual symbols
GC	Atterberg limits above "A" line with P.I. greater than 7	
SW	$C_u = \frac{D_{60}}{D_{10}}$ greater than 6; $C_c = \frac{D_{30}}{D_{10} \times D_{60}}$ between 1 and 3	
SP	Not meeting all gradation requirements for SW	
SM	Atterberg limits below "A" line or P.I. less than 4	Limits plotting in shaded zone with P.I. between 4 and 7 are borderline cases requiring use of dual symbols
SC	Atterberg limits above "A" line with P.I. greater than 7	

Determine percentages of sand and gravel from grain-size curve. Depending on percentage of fines (fraction smaller than No. 200 sieve size), coarse-grained soils are classified as follows:
 Less than 5 percent GW, GP, SW, SP
 More than 12 percent GM, GC, SM, SC
 5 to 12 percent Borderline cases requiring dual symbols

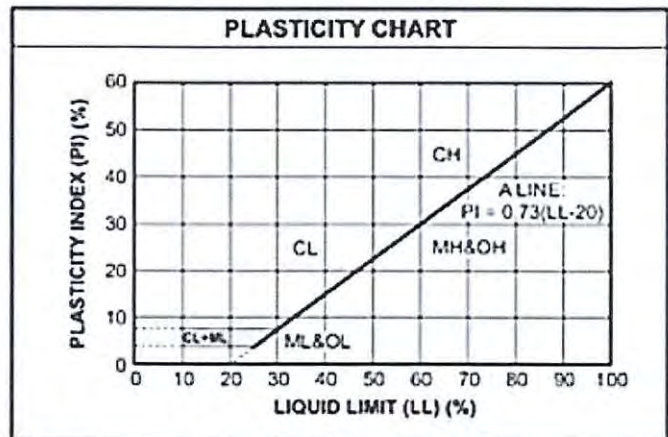



1060 Elizabeth Street
 Suite 7
 Nicholasville, KY 40356

Borehole ID: B-01
 Sheet 1 of 1

Client	Appalachian Wireless Wrigley Tower	Project Name	Appalachian Wireless Wrigley Tower		
Project Number	APS230057	Project Location			
Date Started	Jun 20 2023	Completed:	Jun 20 2023	Drilled By	L Whaley
Drilling Contractor	APS GEO	Latitude:	38.001454	Logged By	L Whaley
Drilling Method	4.25" HSA	Longitude:	-83.277033	Checked By	
Equipment	Mobile B-53	Elevation:	1080.0	Ground Water Levels	
Hammer Type	Automatic				
Notes:	Elevation estimated using Google Earth				

Graphic	Elevation (ft)	Material Description	Depth	Sample No.	Rec [RQD] (%)	Blows (bpf) [N-Value]	Poc. Pen (tsf)	WC (%)	Atterberg Limits			Fine Content %	Remarks
									LL	PL	PI		
		TOPSOIL - 6 inches											
	10.78	Brown, moist to dry, dense, CLAYEY SAND (SC) with trace rootlets	2	SPT-1	80	5-4-34 [38]							
	10.76	Orange-brown, moist to dry, weak rock sampled as a hard soil, weathered SHALE with oxide laminations	4										
	10.74		6	SPT-2	100	21-29-26 [55]							
	10.72	Gray, moist to dry, weak rock sampled as a hard soil, weathered SHALE with oxide laminations	8										
	10.70		10	SPT-3	100	16-21-29 [50]							
	10.68	SHALE, very weak, moderately weathered, very thinly bedded, tan	12										
	10.66		14										
	10.64	SHALE, extremely weak, slightly weathered, thinly bedded, gray	16	SPT-4	100	24-45-50/5 [95]							
	10.62		18	RC-1	100	[0]							
	10.60	COAL, weak, slightly weathered, laminated, black with red and yellow highlights	20	RC-2	72	[12]							
	10.58		22										Coal blocked off the core barrel
	10.56	SILTSTONE, moderately strong, slightly weathered, laminated, gray, with trace sand	24	RC-3	80	[0]							
		End of Borehole at 24.4 ft											



Rock Core Photo: 16.4 feet to 24.4 feet below ground surface.

APPENDIX B: Preliminary Construction Recommendations

Site Preparation and Excavations

The following recommendations are based on our experience and general knowledge of the project. However, APS GEO is not conducting the design of the structures and as such any requirements made by the designer shall take precedence.

In preparing the site for construction, all topsoil and any other deleterious materials should be completely removed from the construction area and any other areas which are to be cut or receive fill. After clearing and stripping is complete, the area should be checked by a representative of the project geotechnical engineer to determine that the clearing and stripping has been sufficient to remove the topsoil and vegetation. Excavations resulting from clearing should be backfilled in accordance with the grading recommendations for the site. Provisions should be made both during and after grading, to protect all exposed earthwork construction areas and earth slopes from erosion as required by the project civil engineer and by applicable Federal, State, and local regulations.

Fill and Backfill Material

The following recommendations are based on our experience and general knowledge of the project. However, APS GEO is not conducting the design of the structures and as such any requirements made by the designer shall take precedence.

On site soils are mostly lean clays (CL) and, therefore, likely suitable material for use as structural fill and backfill provided a drainage layer directly behind the wall face is provided in order to minimize hydrostatic pressures. Fill materials should be approved by the engineer of record before placement. Satisfactory soil materials for structural fill are generally defined as those complying with ASTM D 2487 classification groups GW, GP, and GM for crushed stone and gravel; SM, SW, and SP for sand; and CL and ML for lean clay and silt. Unsatisfactory soils generally include those complying with ASTM D 2487 soil classification groups MH, CH, OL, OH, and Peat. Samples of the proposed fill material should be provided to the engineer of record for laboratory determination of Proctor density and moisture values, and Atterberg limit or other index tests required for classification.

Contractors should allow about one week for the time required to complete the laboratory tests in accordance with ASTM requirements. In general, fill should not include any rocks or rubble larger than 3 inches in diameter. Larger sizes may be approved by the geotechnical engineer. Fill should not contain any significant amounts of organics or debris. Material other than soil, sand and gravel should be considered deleterious material unless the engineer of record states otherwise after visual inspection of the material. Deleterious material should not be used in site fills, regardless of whether it is from an on-site source or delivered to the site. Deleterious material will include organic matter, wood, metal, plastic, and trash.

Earthwork

The following recommendations are based on our experience and general knowledge of the project. However, APS GEO is not conducting the design of the structures and as such any requirements made by the designer shall take precedence.

Fill placement and proof rolling of the exposed subgrade should be monitored by the project geotechnical engineer to verify that unstable materials are not present, and that proper placement and compaction of materials has been accomplished. Before fill and backfill operations begin, representative samples of the proposed fill and backfill material should be tested for determination of laboratory compaction characteristics in accordance with ASTM D 1557 or ASTM D 698 as recommended above. Gradation and liquid and plastic limit determinations should also be accomplished in accordance with ASTM D 6913, D7928 and D 4318 to check material classification.

Compaction of subgrade surfaces, fill, and backfill should be checked with a sufficient number of density tests to assure that adequate compaction is being achieved. Construction specifications should require at least one in-place density test of the compacted fill for every 5,000 square feet of fill placed. For backfill of utility trenches or around structures, construction specifications should require at least one in-place density test per lift for every 50 feet of wall, or fraction thereof. At least one test should be completed per lift regardless of the size or location of the fill area.

APPENDIX C: Limitations and Information about this Report

Important Information about This Geotechnical-Engineering Report

Subsurface problems are a principal cause of construction delays, cost overruns, claims, and disputes.

While you cannot eliminate all such risks, you can manage them. The following information is provided to help

The Geoprofessional Business Association (GBA) has prepared this advisory to help you – assumedly a client representative – interpret and apply this geotechnical-engineering report as effectively as possible. In that way, you can benefit from a lowered exposure to problems associated with subsurface conditions at project sites and development of them that, for decades, have been a principal cause of construction delays, cost overruns, claims, and disputes. If you have questions or want more information about any of the issues discussed herein, contact your GBA-member geotechnical engineer. Active engagement in GBA exposes geotechnical engineers to a wide array of risk-confrontation techniques that can be of genuine benefit for everyone involved with a construction project.

Understand the Geotechnical-Engineering Services Provided for this Report

Geotechnical-engineering services typically include the planning, collection, interpretation, and analysis of exploratory data from widely spaced borings and/or test pits. Field data are combined with results from laboratory tests of soil and rock samples obtained from field exploration (if applicable), observations made during site reconnaissance, and historical information to form one or more models of the expected subsurface conditions beneath the site. Local geology and alterations of the site surface and subsurface by previous and proposed construction are also important considerations. Geotechnical engineers apply their engineering training, experience, and judgment to adapt the requirements of the prospective project to the subsurface model(s). Estimates are made of the subsurface conditions that will likely be exposed during construction as well as the expected performance of foundations and other structures being planned and/or affected by construction activities.

The culmination of these geotechnical-engineering services is typically a geotechnical-engineering report providing the data obtained, a discussion of the subsurface model(s), the engineering and geologic engineering assessments and analyses made, and the recommendations developed to satisfy the given requirements of the project. These reports may be titled investigations, explorations, studies, assessments, or evaluations. Regardless of the title used, the geotechnical-engineering report is an engineering interpretation of the subsurface conditions within the context of the project and does not represent a close examination, systematic inquiry, or thorough investigation of all site and subsurface conditions.

Geotechnical-Engineering Services are Performed for Specific Purposes, Persons, and Projects, and At Specific Times

Geotechnical engineers structure their services to meet the specific needs, goals, and risk management preferences of their clients. A geotechnical-engineering study conducted for a given civil engineer

will not likely meet the needs of a civil-works constructor or even a different civil engineer. Because each geotechnical-engineering study is unique, each geotechnical-engineering report is unique, prepared solely for the client.

Likewise, geotechnical-engineering services are performed for a specific project and purpose. For example, it is unlikely that a geotechnical-engineering study for a refrigerated warehouse will be the same as one prepared for a parking garage; and a few borings drilled during a preliminary study to evaluate site feasibility will not be adequate to develop geotechnical design recommendations for the project.

Do not rely on this report if your geotechnical engineer prepared it:

- for a different client;
- for a different project or purpose;
- for a different site (that may or may not include all or a portion of the original site); or
- before important events occurred at the site or adjacent to it; e.g., man-made events like construction or environmental remediation, or natural events like floods, droughts, earthquakes, or groundwater fluctuations.

Note, too, the reliability of a geotechnical-engineering report can be affected by the passage of time, because of factors like changed subsurface conditions; new or modified codes, standards, or regulations; or new techniques or tools. If you are the least bit uncertain about the continued reliability of this report, contact your geotechnical engineer before applying the recommendations in it. A minor amount of additional testing or analysis after the passage of time – if any is required at all – could prevent major problems.

Read this Report in Full

Costly problems have occurred because those relying on a geotechnical-engineering report did not read the report in its entirety. Do not rely on an executive summary. Do not read selective elements only. Read and refer to the report in full.

You Need to Inform Your Geotechnical Engineer About Change

Your geotechnical engineer considered unique, project-specific factors when developing the scope of study behind this report and developing the confirmation-dependent recommendations the report conveys. Typical changes that could erode the reliability of this report include those that affect:

- the site's size or shape;
- the elevation, configuration, location, orientation, function or weight of the proposed structure and the desired performance criteria;
- the composition of the design team; or
- project ownership.

As a general rule, *always* inform your geotechnical engineer of project or site changes – even minor ones – and request an assessment of their impact. *The geotechnical engineer who prepared this report cannot accept*

responsibility or liability for problems that arise because the geotechnical engineer was not informed about developments the engineer otherwise would have considered.

Most of the "Findings" Related in This Report Are Professional Opinions

Before construction begins, geotechnical engineers explore a site's subsurface using various sampling and testing procedures. *Geotechnical engineers can observe actual subsurface conditions only at those specific locations where sampling and testing is performed.* The data derived from that sampling and testing were reviewed by your geotechnical engineer, who then applied professional judgement to form opinions about subsurface conditions throughout the site. Actual sitewide subsurface conditions may differ – maybe significantly – from those indicated in this report. Confront that risk by retaining your geotechnical engineer to serve on the design team through project completion to obtain informed guidance quickly, whenever needed.

This Report's Recommendations Are Confirmation-Dependent

The recommendations included in this report – including any options or alternatives – are confirmation-dependent. In other words, they are not final, because the geotechnical engineer who developed them relied heavily on judgement and opinion to do so. Your geotechnical engineer can finalize the recommendations *only after observing actual subsurface conditions* exposed during construction. If through observation your geotechnical engineer confirms that the conditions assumed to exist actually do exist, the recommendations can be relied upon, assuming no other changes have occurred. *The geotechnical engineer who prepared this report cannot assume responsibility or liability for confirmation-dependent recommendations if you fail to retain that engineer to perform construction observation.*

This Report Could Be Misinterpreted

Other design professionals' misinterpretation of geotechnical engineering reports has resulted in costly problems. Confront that risk by having your geotechnical engineer serve as a continuing member of the design team, to:

- confer with other design-team members;
- help develop specifications;
- review pertinent elements of other design professionals' plans and specifications; and
- be available whenever geotechnical-engineering guidance is needed.

You should also confront the risk of constructors misinterpreting this report. Do so by retaining your geotechnical engineer to participate in prebid and preconstruction conferences and to perform construction-phase observations.

Give Constructors a Complete Report and Guidance

Some owners and design professionals mistakenly believe they can shift unanticipated-subsurface-conditions liability to constructors by limiting the information they provide for bid preparation. To help prevent the costly, contentious problems this practice has caused, include the complete geotechnical-engineering report, along with any attachments or appendices, with your contract documents, *but be certain to note*

conspicuously that you've included the material for information purposes only. To avoid misunderstanding, you may also want to note that "informational purposes" means constructors have no right to rely on the interpretations, opinions, conclusions, or recommendations in the report. Be certain that constructors know they may learn about specific project requirements, including options selected from the report, *only* from the design drawings and specifications. Remind constructors that they may perform their own studies if they want to, and *be sure to allow enough time* to permit them to do so. Only then might you be in a position to give constructors the information available to you, while requiring them to at least share some of the financial responsibilities stemming from unanticipated conditions. Conducting prebid and preconstruction conferences can also be valuable in this respect.

Read Responsibility Provisions Closely

Some client representatives, design professionals, and constructors do not realize that geotechnical engineering is far less exact than other engineering disciplines. This happens in part because soil and rock on project sites are typically heterogeneous and not manufactured materials with well-defined engineering properties like steel and concrete. That lack of understanding has nurtured unrealistic expectations that have resulted in disappointments, delays, cost overruns, claims, and disputes. To confront that risk, geotechnical engineers commonly include explanatory provisions in their reports. Sometimes labeled "limitations," many of these provisions indicate where geotechnical engineers' responsibilities begin and end, to help others recognize their own responsibilities and risks. *Read these provisions closely.* Ask questions. Your geotechnical engineer should respond fully and frankly.

Geoenvironmental Concerns Are Not Covered

The personnel, equipment, and techniques used to perform an environmental study – e.g., a "phase one" or "phase two" environmental site assessment – differ significantly from those used to perform a geotechnical-engineering study. For that reason, a geotechnical-engineering report does not usually provide environmental findings, conclusions, or recommendations; e.g., about the likelihood of encountering underground storage tanks or regulated contaminants. *Unanticipated subsurface environmental problems have led to project failures.* If you have not obtained your own environmental information about the project site, ask your geotechnical consultant for a recommendation on how to find environmental risk management guidance.

Obtain Professional Assistance to Deal with Moisture Infiltration and Mold

While your geotechnical engineer may have addressed groundwater, water infiltration, or similar issues in this report, the engineer's services were not designed, conducted, or intended to prevent migration of moisture – including water vapor – from the soil through building slabs and walls and into the building interior, where it can cause mold growth and material-performance deficiencies. Accordingly, *proper implementation of the geotechnical engineer's recommendations will not of itself be sufficient to prevent moisture infiltration.* Confront the risk of moisture infiltration by including building envelope or mold specialists on the design team. *Geotechnical engineers are not building-envelope or mold specialists.*



Telephone: 301/565-2733

e-mail: info@geoprofessional.org www.geoprofessional.org

Copyright 2019 by Geoprofessional Business Association (GBA). Duplication, reproduction, or copying of this document, in whole or in part, by any means whatsoever, is strictly prohibited, except with GBA's specific written permission. Excerpting, quoting, or otherwise extracting wording from this document is permitted only with the express written permission of GBA, and only for purposes of scholarly research or book review. Only members of GBA may use this document or its wording as a complement to or as an element of a report of any kind. Any other firm, individual, or other entity that so uses this document without being a GBA member could be committing negligent or intentional (fraudulent) misrepresentation.

Exhibit 5



World Tower
COMPANY, INC.

1213 Compressor Drive
P.O. Box 508
Mayfield, KY 42066
270-247-3642
FAX: 270-247-0909
E-mail: worldtower@worldtower.com
Web: www.worldtower.com

190' MODEL WSST TOWER
FOR: APPALACHIAN WIRELESS
SITE: POMP
MORGAN COUNTY, KY
DESIGN PACKAGE



2-12-2024



WORLD TOWER

1213 COMPRESSOR DRIVE
MAYFIELD, KY 42066
P: 270-246-3642 F: 270-247-0909
WWW.WORLDTOWER.COM

GENERAL TOWER NOTES:

1. WELDED CONNECTIONS SHALL CONFORM TO THE LATEST REVISION OF THE AMERICAN WELDING SOCIETY AWS. D 1.1.
2. TOWER AND ALL FABRICATED ACCESSORIES ARE HOT-DIP GALVANIZED.
3. ALL BOLTS SHALL BE GALVANIZED ACCORDING TO THE STANDARD SPECIFICATION FOR ZINC COATING OF IRON AND STEEL HARDWARE ASTM A153.
4. LEG STEEL IS 50 KSI MIN YIELD SOLID ROUND OR PIPE AND BRACING STEEL IS 36 KSI MIN YIELD SOLID ROUND OR STRUCTURAL ANGLE.
5. ALL STRUCTURAL BOLTS ARE ASTM A325.
6. TOWER SHOULD BE INSPECTED IN ACCORDANCE WITH TIA-222-G EVERY 5 YEARS.
7. TOWER INSPECTION SHOULD ONLY BE PERFORMED BY EXPERIENCED QUALIFIED PERSONNEL. FOR ASSISTANCE IN PROPER MAINTENANCE OF YOUR TOWER, CALL WORLD TOWER AT 270-247-3642.

SEAL



2-12-2024

LKC	REVISED SITE NAME	LKC	2-12-24
REV.	DESCRIPTION	BY	DATE

190' MODEL WSST TOWER
FOR: APPALACHIAN WIRELESS
SITE: POMP
MORGAN COUNTY, KY

SCALE	NONE	DWN.	LKC	CKD.	DATE	2-9-24
FILE				DWG. NO.	Q240011N	

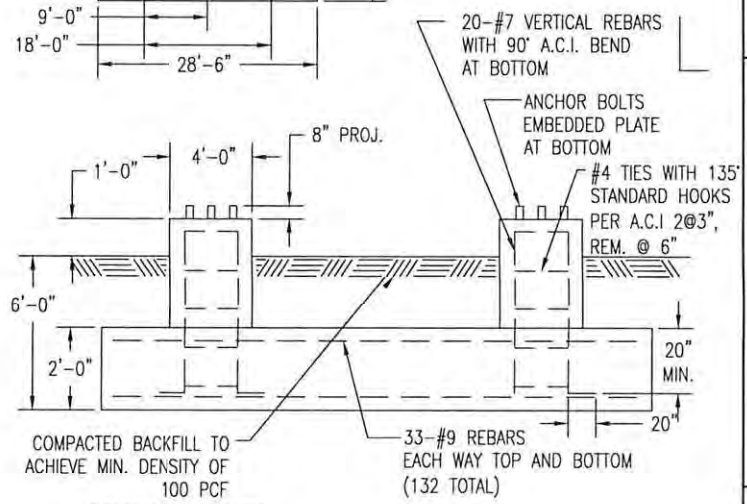
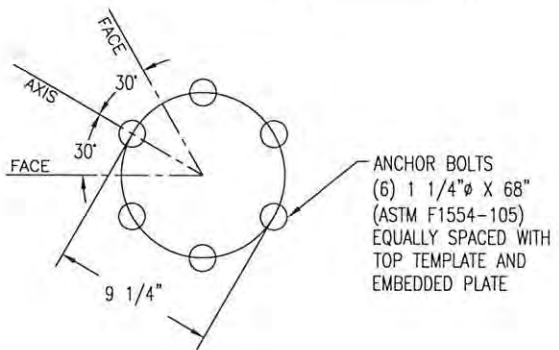
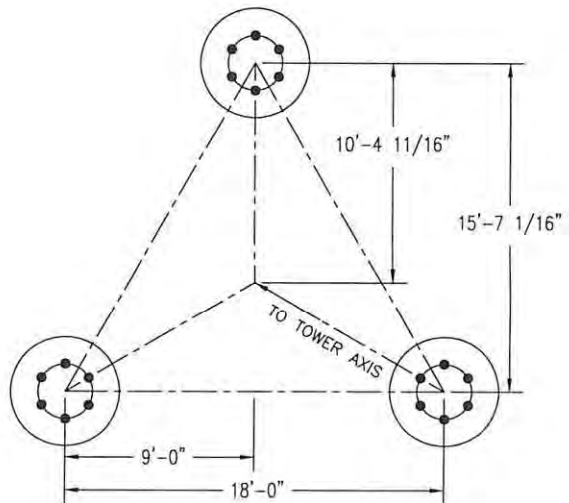
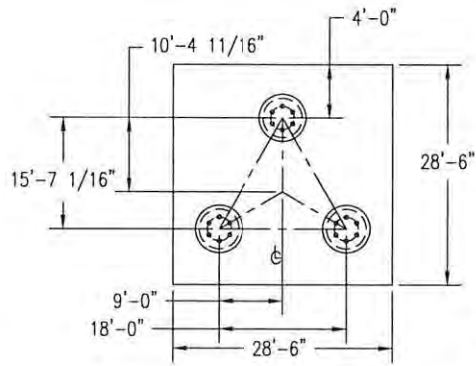
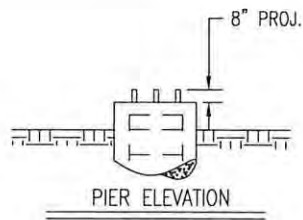

- FOUNDATION NOTES**
1. CONCRETE TO HAVE 4000 PSI MINIMUM COMPRESSIVE STRENGTH AFTER 28 DAYS.
 2. ALL REINFORCEMENT STEEL IS DEFORMED AND MEETS THE STRENGTH REQUIREMENTS OF ASTM A615 GRADE 60.
 3. EMBEDDED STEEL TO HAVE 3" MINIMUM CONCRETE COVER.
 4. FOUNDATION DESIGN IS BASED UPON CUSTOMER SUPPLIED SOILS DATA BY APS. PROJECT NUMBER APS230057 DATED JULY 24, 2023.

67.2 CU. YDS.
CONCRETE REQ'D.

BASE REACTIONS	
OTM:	6747.0 FT. KIPS
COMP.	455.0 KIPS
UPLIFT	406.0 KIPS
SHEAR (3 LEGS)	55.0 KIPS
WT. NO ICE	66.0 KIPS
WT. 3/4" ICE	230.0 KIPS



WORLD TOWER
1213 COMPRESSOR DRIVE
MAYFIELD, KY 42066
P: 270-246-3642 F: 270-247-0909
WWW.WORLDTOWER.COM



2-12-2024

REV.	DESCRIPTION	BY	DATE
R1	REVISED SITE NAME	LKC	2-12-24

190' MODEL WSST TOWER
FOR: APPALACHIAN WIRELESS
SITE: POMP
MORGAN COUNTY, KY

SCALE	NONE	DWN.	LKC	CKD.	DATE	2-9-24
FILE				ENCL. NO.	Q240011	

Section	110	19	18	17	16	15	14	13	12	11
Legs	SR 4 1/4	SR 4	SR 3 3/4	SR 3 1/2	SR 3 1/4	SR 3	SR 2 1/2	SR 2 1/4	SR 1 3/4	SR 1 3/4
Leg Grade										
Diagonals	L3 1/2x3 1/2x1/4		L3x3x1/4		L3x3x3/16		L2 1/2x2 1/2x3/16		L1 3/4x1 3/4x3/16	
Diagonal Grade					A572-50					
Top Girts					A36					A
Horizontals	L3x3x3/16		L2 1/2x2 1/2x3/16		N.A.					
Face Width (ft)	16	14.5	13	11.5	10	8.5	7	5.5	4	
# Panels @ (ft)		4.5	4.2	3.7	3.3	2.7	2.3	1.8	1.3	0.5
Weight (K)	29.1	5.0			38 @ 5					

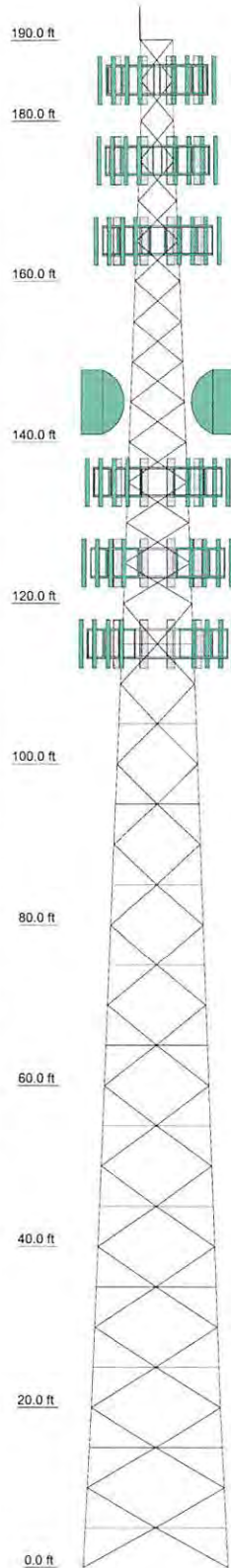

SYMBOL LIST

MARK	SIZE	MARK	SIZE
A	L1 3/4x1 3/4x3/16		

MATERIAL STRENGTH

GRADE	Fy	Fu	GRADE	Fy	Fu
A572-50	50 ksi	65 ksi	A36	36 ksi	58 ksi

TOWER DESIGN NOTES

1. Tower is located in Morgan County, Kentucky.
2. Tower designed for Exposure C to the TIA-222-G Standard.
3. Tower designed for a 105.00 mph basic wind in accordance with the TIA-222-G Standard.
4. Tower is also designed for a 30.00 mph basic wind with 0.75 in ice. Ice is considered to increase in thickness with height.
5. Deflections are based upon a 60.00 mph wind.
6. Tower Risk Category II.
7. Topographic Category 1 with Crest Height of 0.00 ft
8. TOWER RATING: 99.8%



2-14-2024

ALL REACTIONS
ARE FACTORED

MAX. CORNER REACTIONS AT BASE:

DOWN: 455 K
SHEAR: 35 K

UPLIFT: -406 K
SHEAR: 31 K

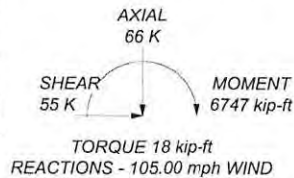
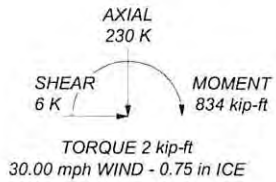

World Tower Company			
1213 Compressor Drive			
Mayfield, KY 42066			
Phone: (270) 247-3642			
FAX: www.worldtower.com			
Job:	190' WSST Tower / WTC Q24-011		
Project:	Wrigley / Pump Site		
Client:	Appalachian Wireless	Drawn by:	kirk
Code:	TIA-222-G	Date:	02/14/24
Path:	C:\Tower\PE Runs\2024\Q24-011 wrigley pump\Q24-011.dwg		
Scale:	NTS		Dwg No. E-1

Exhibit 6



Mail Processing Center
 Federal Aviation Administration
 Southwest Regional Office
 Obstruction Evaluation Group
 10101 Hillwood Parkway
 Fort Worth, TX 76177

Aeronautical Study No.
 2023-ASO-10430-OE

Issued Date: 10/03/2023

Cindy D. McCarty
 East Kentucky Network, LLC
 101 Technology Trail
 Ivel, KY 41642

**** DETERMINATION OF NO HAZARD TO AIR NAVIGATION ****

The Federal Aviation Administration has conducted an aeronautical study under the provisions of 49 U.S.C., Section 44718 and if applicable Title 14 of the Code of Federal Regulations, part 77, concerning:

Structure:	Antenna Tower Wrigley
Location:	West Liberty, KY
Latitude:	38-00-03.04N NAD 83
Longitude:	83-16-37.78W
Heights:	1108 feet site elevation (SE)
	190 feet above ground level (AGL)
	1298 feet above mean sea level (AMSL)

This aeronautical study revealed that the structure does not exceed obstruction standards and would not be a hazard to air navigation provided the following condition(s), if any, is(are) met:

It is required that FAA Form 7460-2, Notice of Actual Construction or Alteration, be e-filed any time the project is abandoned or:

- At least 10 days prior to start of construction (7460-2, Part 1)
- Within 5 days after the construction reaches its greatest height (7460-2, Part 2)

Based on this evaluation, marking and lighting are not necessary for aviation safety. However, if marking/lighting are accomplished on a voluntary basis, we recommend it be installed in accordance with FAA Advisory circular 70/7460-1 M.

This determination expires on 04/03/2025 unless:

- (a) the construction is started (not necessarily completed) and FAA Form 7460-2, Notice of Actual Construction or Alteration, is received by this office.
- (b) extended, revised, or terminated by the issuing office.
- (c) the construction is subject to the licensing authority of the Federal Communications Commission (FCC) and an application for a construction permit has been filed, as required by the FCC, within 6 months of the date of this determination. In such case, the determination expires on the date prescribed by the FCC for completion of construction, or the date the FCC denies the application.

NOTE: REQUEST FOR EXTENSION OF THE EFFECTIVE PERIOD OF THIS DETERMINATION MUST BE E-FILED AT LEAST 15 DAYS PRIOR TO THE EXPIRATION DATE. AFTER RE-EVALUATION OF CURRENT OPERATIONS IN THE AREA OF THE STRUCTURE TO DETERMINE THAT NO SIGNIFICANT AERONAUTICAL CHANGES HAVE OCCURRED, YOUR DETERMINATION MAY BE ELIGIBLE FOR ONE EXTENSION OF THE EFFECTIVE PERIOD.

This determination is based, in part, on the foregoing description which includes specific coordinates, heights, frequency(ies) and power. Any changes in coordinates, heights, and frequencies or use of greater power, except those frequencies specified in the Colo Void Clause Coalition; Antenna System Co-Location; Voluntary Best Practices, will void this determination. Any future construction or alteration, including increase to heights, power, or the addition of other transmitters, requires separate notice to the FAA. This determination includes all previously filed frequencies and power for this structure.

If construction or alteration is dismantled or destroyed, you must submit notice to the FAA within 5 days after the construction or alteration is dismantled or destroyed.

This determination does include temporary construction equipment such as cranes, derricks, etc., which may be used during actual construction of the structure. However, this equipment shall not exceed the overall heights as indicated above. Equipment which has a height greater than the studied structure requires separate notice to the FAA.

This determination concerns the effect of this structure on the safe and efficient use of navigable airspace by aircraft and does not relieve the sponsor of compliance responsibilities relating to any law, ordinance, or regulation of any Federal, State, or local government body.

A copy of this determination will be forwarded to the Federal Communications Commission (FCC) because the structure is subject to their licensing authority.

If we can be of further assistance, please contact our office at (718) 553-2611, or angelique.eersteling@faa.gov. On any future correspondence concerning this matter, please refer to Aeronautical Study Number 2023-ASO-10430-OE.

Signature Control No: 576364896-600906141

(DNE)

Angelique Eersteling
Technician

Attachment(s)
Case Description
Frequency Data
Map(s)

cc: FCC

Case Description for ASN 2023-ASO-10430-OE

A new 180' self supporting with top mounted antenna (overall height of 190')

Frequency Data for ASN 2023-ASO-10430-OE

LOW FREQUENCY	HIGH FREQUENCY	FREQUENCY UNIT	ERP	ERP UNIT
6	7	GHz	55	dBW
6	7	GHz	42	dBW
10	11.7	GHz	55	dBW
10	11.7	GHz	42	dBW
17.7	19.7	GHz	55	dBW
17.7	19.7	GHz	42	dBW
21.2	23.6	GHz	55	dBW
21.2	23.6	GHz	42	dBW
614	698	MHz	1000	W
614	698	MHz	2000	W
698	806	MHz	1000	W
806	901	MHz	500	W
806	824	MHz	500	W
824	849	MHz	500	W
851	866	MHz	500	W
869	894	MHz	500	W
896	901	MHz	500	W
901	902	MHz	7	W
929	932	MHz	3500	W
930	931	MHz	3500	W
931	932	MHz	3500	W
932	932.5	MHz	17	dBW
935	940	MHz	1000	W
940	941	MHz	3500	W
1670	1675	MHz	500	W
1710	1755	MHz	500	W
1850	1910	MHz	1640	W
1850	1990	MHz	1640	W
1930	1990	MHz	1640	W
1990	2025	MHz	500	W
2110	2200	MHz	500	W
2305	2360	MHz	2000	W
2305	2310	MHz	2000	W
2345	2360	MHz	2000	W
2496	2690	MHz	500	W

TOPO Map for ASN 2023-ASO-10430-OE

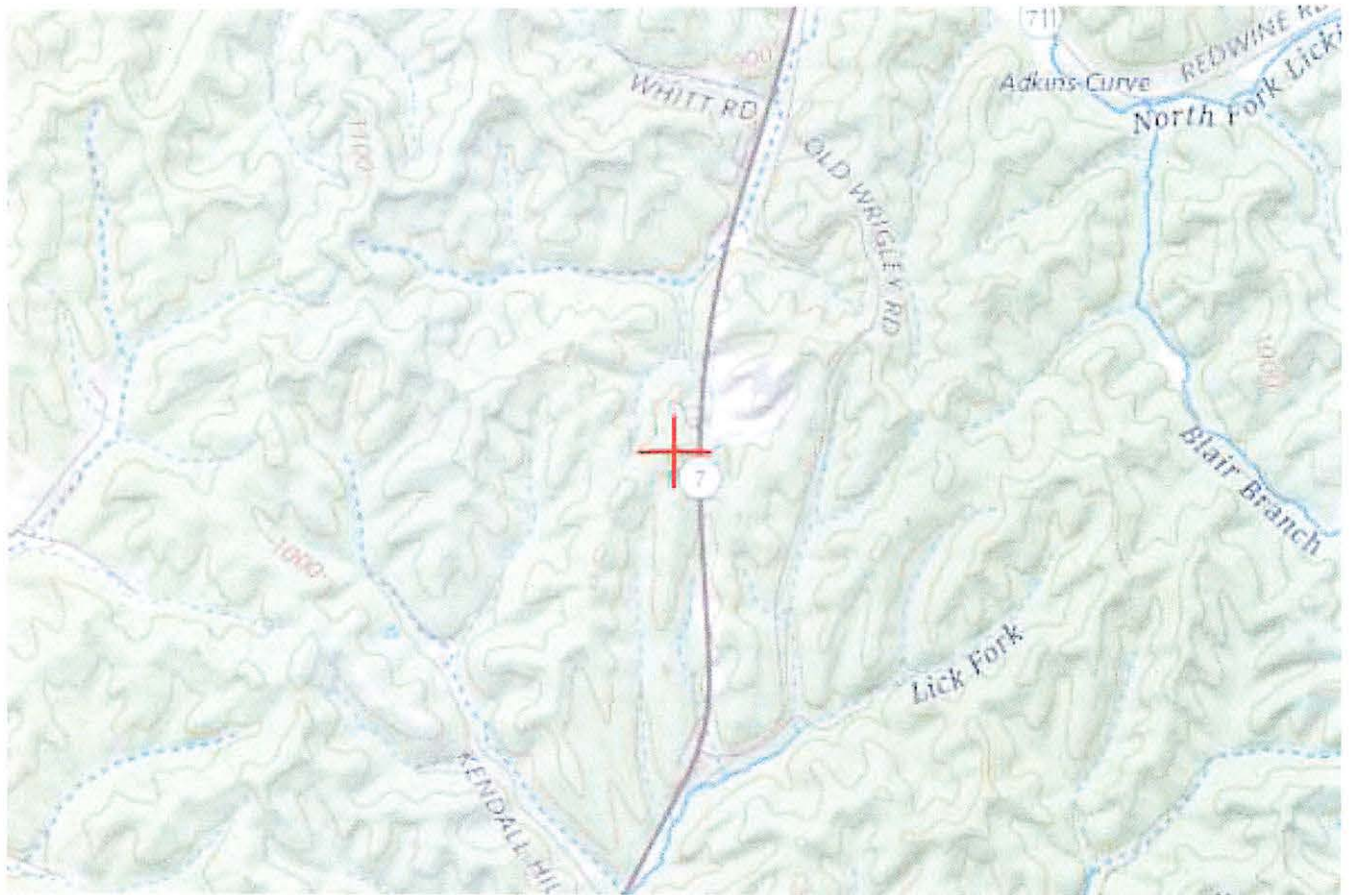

Sectional Map for ASN 2023-ASO-10430-OE

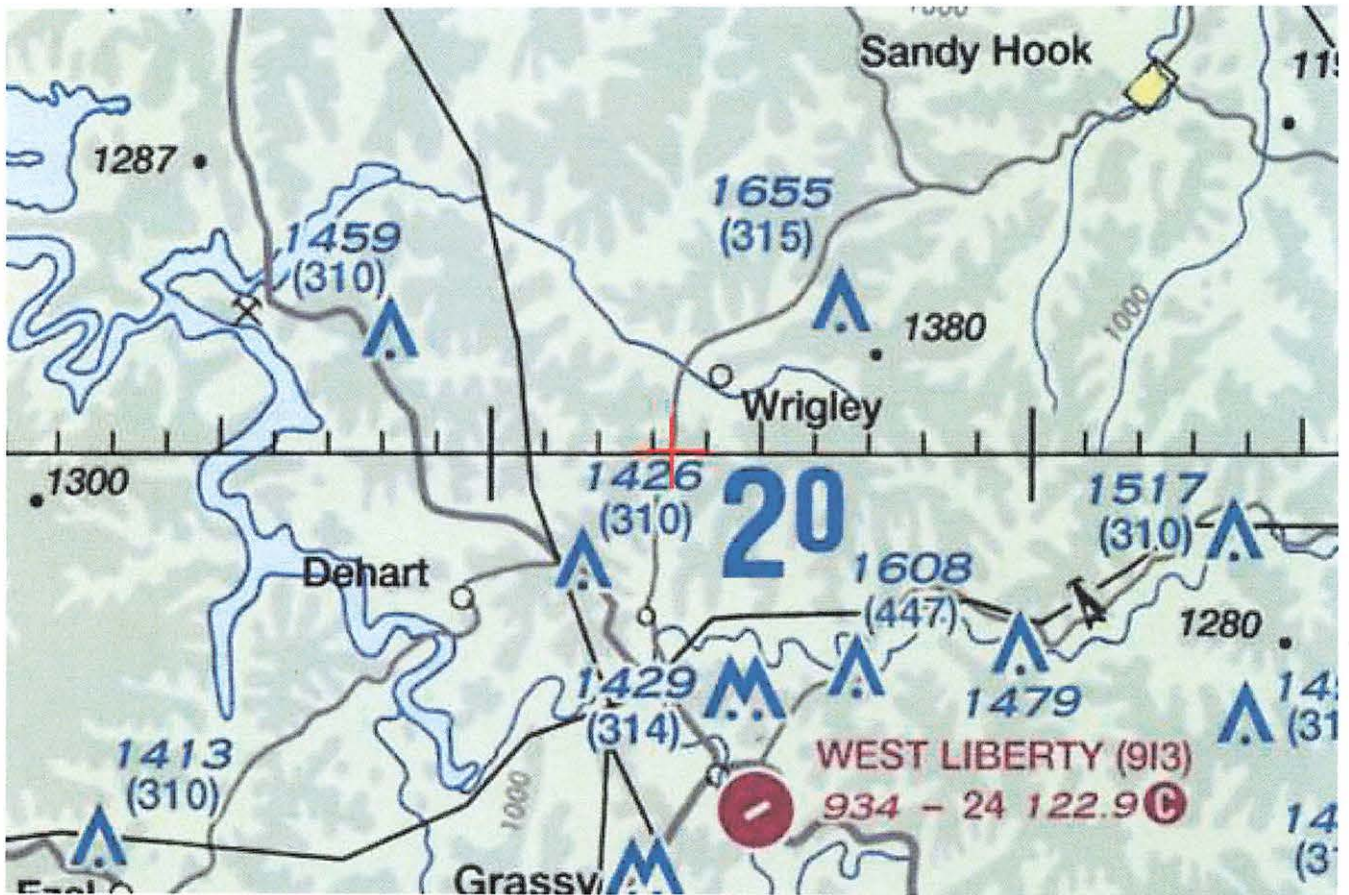

From: Airport Zoning Commission <AirportZoning@ky.gov>
Date: Thursday, March 16, 2023 at 12:24 PM
To: Raina Helton <rhelton@ekn.com>, Airport Zoning Commission <AirportZoning@ky.gov>
Cc: Cindy McCarty <cmccarty@ekn.com>, Tonya Taylor <ttaylor@ekn.com>
Subject: RE: KAZC Application- Pomp

Raina,

I ran the coordinates and height you submitted.
This structure is not in KAZC's jurisdiction, and no permit is required.

Thank you for checking.

Call us with any questions.
Respectfully,



Anthony Adams
AIRPORT ZONING
COMMISSION, ADMINISTRATOR
Department of Aviation
90 Airport Road, Bldg 400
Frankfort, Kentucky 40601
(502) 564-0151
(502) 564-0570 Direct Line
(502) 330-4022 Mobile
[Airport Zoning Commission | KYTC](#)

From: Raina Helton <rhelton@ekn.com>
Sent: Wednesday, March 15, 2023 2:43 PM
To: Airport Zoning Commission <AirportZoning@ky.gov>
Cc: Cindy McCarty <cmccarty@ekn.com>; Tonya Taylor <ttaylor@ekn.com>
Subject: KAZC Application- Pomp

****CAUTION** PDF attachments may contain links to malicious sites. Please contact the COT Service Desk ServiceCorrespondence@ky.gov for any assistance.**

Please find attached the application for permit to construct a structure for a new site called Pomp.

Thanks.

Raina Helton, CKP
Regulatory Compliance Director
East Kentucky Network, LLC
dba Appalachian Wireless
(606) 339-1005
Fax (606) 339-1363

CAUTION: This email originated from outside of East Kentucky Network. Do not follow instructions, click links, or open attachments unless you recognize the sender and know the content is safe.

Exhibit 7

Driving Directions

1. Beginning in West Liberty, in Morgan County, KY on Court Street
2. Drive approximately two hundred feet to the intersection of Court St. and Main St.
3. Turn right onto Main St (460 & 7)
4. Drive 2.7 miles to the intersection of Hwy 7 and Hwy 519
5. Turn right onto Hwy 7
6. Drive 3.9 miles
7. On the left is a gated road, access by appointment only (Patrick cemetery) (sign will be posted here)
8. Drive through the gate
9. Stay to your left
10. Drive through another gate
11. Drive approximately .4 miles to the top of the hill
12. You will arrive at the site (sign will be posted)

Prepared By:

Daryl Bartley
Cell Site Compliance Agent
Appalachian Wireless
(606) 791-0310 (cell)

Pomp

Location:
7485 Route 7
West Liberty, KY
41472

Coordinates:
Lat: 38°00'03.04"N
Lon: 83°16'37.78"W

Leg 1
 .5 Mile Radius



Exhibit 8

PCI
50
15
65

LODGED FOR RECORD
MORGAN COUNTY CLERK

MAR 21 2023

TIME: 12:21 PM
RANDY WILLIAMS CLERK

MEMORANDUM OF LEASE

Lessee

THIS MEMORANDUM OF LEASE is made and entered into on this 1st day of March, 202~~1~~³, with a commencement date of March 1, 2023 (the "Commencement Date"), by and between **DARRELL PATRICK** and **LINDA PATRICK**, a married couple, with an address of 93 HWY 1002, West Liberty, Kentucky 41472, hereinafter referred to as "**Lessors**", and **EAST KENTUCKY NETWORK, LLC D/B/A APPALACHIAN WIRELESS**, a Kentucky limited liability company, with a mailing address of 101 Technology Trail, Ivel, Kentucky, 41642, hereinafter referred to as "**Lessee.**"

WITNESSETH

1. **Demised Premises.** For good and valuable consideration, Lessors leased to Lessee, and Lessee has leased from Lessors that certain tract of real estate located in Morgan County, Kentucky, and being a portion of the same land conveyed to Darrell Patrick by Deed dated November 8, 2010, and recorded on even date, in Deed Book 219, Page 405, in the Morgan County Clerk's Office. Said property is more particularly described in the description **attached** hereto and made a part hereof as **Exhibit A** and the plat **attached** hereto and made a part hereof as **Exhibit B**, prepared by Tim Malone, Licensed Professional Land Surveyor (hereinafter referred to as the "**Premises**"). The Lessors have further granted Lessee the right to temporarily place a Cell on Wheels (C.O.W.) upon Lessor's property at the approximate location depicted in the map **attached** hereto and made a part hereof as **Exhibit C** until such time as Lessee can complete the construction of a cellular tower and related facilities and equipment upon the Premises. The Lessors have also granted unto Lessee full and complete rights of ingress, egress and regress to and from the Premises over any property owned by Lessors and other associated rights for installation of utilities,

maintenance, and other purposes. Lessee has the absolute right to assign, sublease, sublicense or otherwise transfer, in whole or in part, the Leased Premises and the easements and rights-of-way.

2. **Term.** The initial term of the Lease is for a period of five (5) years from the Commencement Date set forth above.

3. **Renewals.** The Lease shall automatically renew for an additional seven (7) terms of five (5) years each, unless Lessee provides sixty (60) days written notice prior to the end of the current term that it does not wish to renew.

4. **Binding Effect.** All of the terms, conditions, and covenants hereof shall be binding and inure to the benefit of the parties and their respective heirs, representatives, successors, and assigns.

5. **Purpose.** This Memorandum of Lease is prepared solely for the purpose of recordation, and is not intended to, nor shall it be deemed to, modify any of the terms and conditions set forth in the Lease, nor to construe any of the rights, duties or responsibilities of Lessors and Lessee. In the event of any conflict between the terms and conditions of this Memorandum and the terms and conditions of the Lease, the terms and conditions of the Lease shall supersede and control.

[THE REMAINDER OF THIS PAGE INTENTIONALLY LEFT BLANK.]

IN WITNESS WHEREOF, Lessors and Lessee have caused their names to be signed hereto, as of the date(s) indicated below.

LESSORS:

Darrell Patrick
DARRELL PATRICK

Linda Patrick
LINDA PATRICK

COMMONWEALTH OF KENTUCKY
COUNTY OF Morgan

The foregoing instrument was acknowledged before me on this 28th day of February, 2023, by Darrell Patrick and Linda Patrick, Lessors.

Russell S. Altus
Notary Public
Commission No.: KYNP375

My Commission Expires 2-6-2024

[SIGNATURES CONTINUE ON NEXT PAGE.]

LESSEE:

EAST KENTUCKY NETWORK, LLC D/B/A
APPALACHIAN WIRELESS

Michael Johnson
By: Michael L. Johnson
Its: CEO

COMMONWEALTH OF KENTUCKY
COUNTY OF Floyd

The foregoing instrument was acknowledged before me on this 1st day of March, 2023, by Michael L. Johnson, CEO of East Kentucky Network, LLC d/b/a Appalachian Wireless, Lessee.

Ramin H. Hester
Notary Public
Commission No.: KYNP375

My Commission Expires 2-6-2024

This instrument was prepared by:

Krystal Branham
Krystal Branham, Attorney
101 Technology Trail
Ivel, Kentucky 41642
(606) 477-2355

EXHIBIT A
LEGAL DESCRIPTION

LEASE BOUNDARY DESCRIPTION
East Kentucky Network LLC - Pomp Tower

A certain tract of land located on the ridge between Town Branch and Lick Fork on the waters of the North Fork of the Licking River near the community of Wrigley in Morgan County, Kentucky, more particularly described as follows:

Unless stated otherwise, any monument referred to herein as a "corner monument set" or "reference monument set" is a set 5/8" diameter rebar, eighteen inches (18") in length, with a yellow plastic cap stamped "MALONE 3480". All bearings and coordinates stated herein are referred to the Kentucky State Plane Coordinate System, South Zone, NAD 83, U.S. Survey Feet.

Beginning at a corner monument (set) on the former ridgeline between Town Branch of the North Fork of the Licking River and Lick Fork of Elk Fork of the Licking River, said point having a State Plane coordinate of **N: 2,257,014.63 feet and E: 2,352,967.91 feet**, said point being a common corner between Darrell Patrick (Deed Book 219 PG 405) and the Commonwealth of Kentucky (DB 184 PG 781) and being on the west right of way of KY Route 7 at a point 221.87 feet left of centerline station 360+13.22 feet, thence with the right of way **S 05°14'22" W a distance of 253.34 feet** to a corner monument (set) on the right of way at a point 248.14 feet left of centerline station 357+67.09 feet, said corner being a common corner with the Commonwealth of Kentucky, Robert Caskey (Deed Book 192 PG 783) and the parent tract; thence leaving the right of way and with the Caskey tract **N 27°03'11" W a distance of 79.75 feet** to a corner monument (set); thence **S 83°55'40" W a distance of 65.14 feet** to a corner monument (set); thence leaving the Caskey tract and dividing the parent tract **N 27°32'51" W a distance of 59.96 feet** to a corner monument (set); thence **N 35°04'14" E a distance of 159.83 feet** to a corner monument (set); thence **N 86°01'53" E a distance of 60.22 feet** to the **Point of Beginning**.

Also to be included is a permanent access easement from the public road to the leased tract described herein. Also to be included is a right to install fiber optic and utility lines in or along said access road and/or such other location to be agreed upon by the parties.

Said parcel having an area of **20,711 square feet or 0.48 acres**, according to a survey by Tim Malone, PLS #3480 with Synergy Engineering Services, PLLC, on December 30, 2022. Said parcel being a portion of the same tract of land that was conveyed to Darrell Patrick from Ishmael Patrick, et al. by deed dated November 8, 2010 which is recorded in Deed Book 219, Page 405, as found within the records of the Morgan County Clerk's office, West Liberty, Kentucky.



01/03/23
Tim Malone, PLS #3480 Date

EXHIBIT B

PLAT MAP

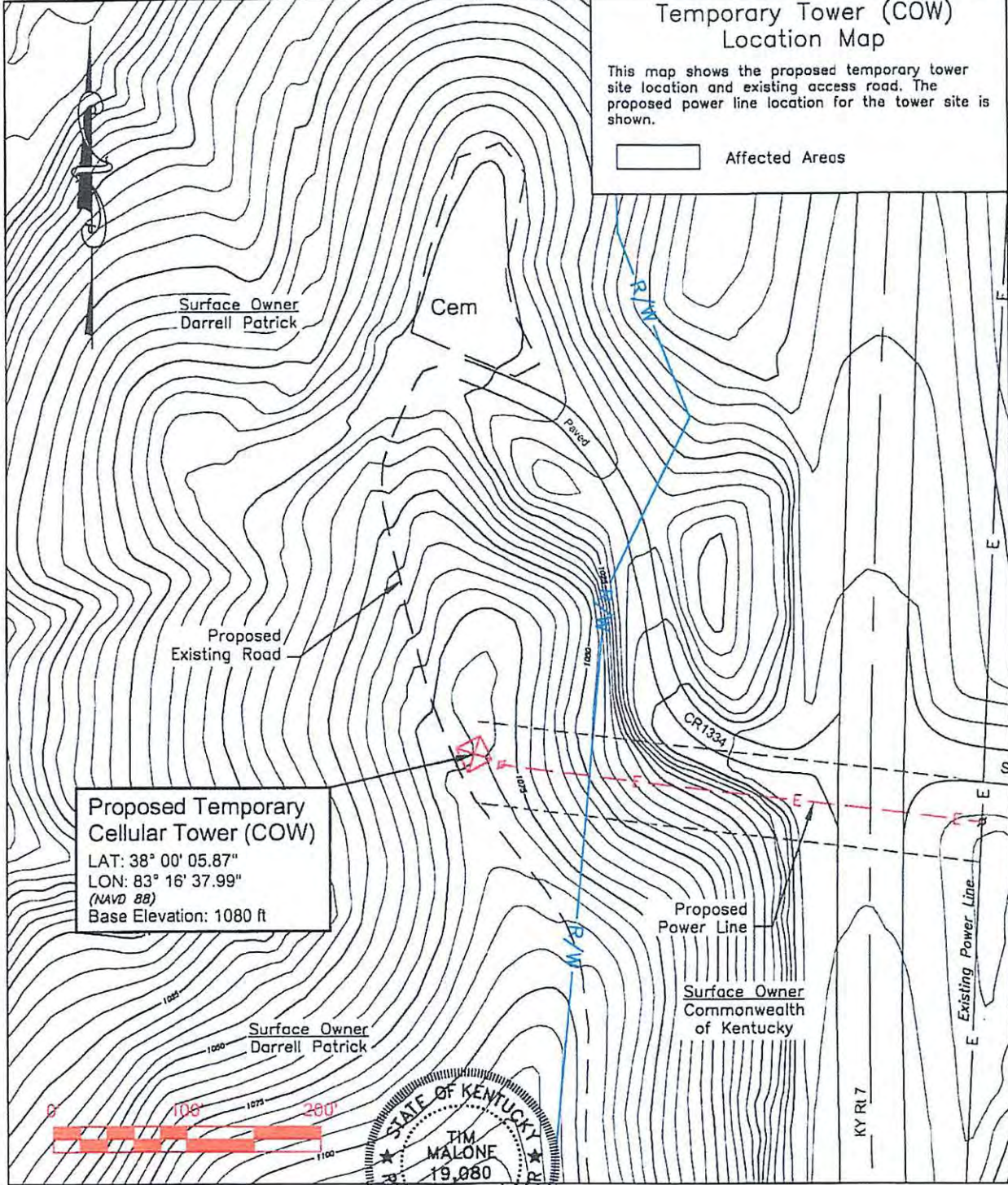

EXHIBIT C
COW TOWER LOCATION MAP

Temporary Tower (COW) Location Map

This map shows the proposed temporary tower site location and existing access road. The proposed power line location for the tower site is shown.

 Affected Areas



Proposed Temporary Cellular Tower (COW)
 LAT: 38° 00' 05.87"
 LON: 83° 16' 37.99"
 (NAVD 88)
 Base Elevation: 1080 ft



Tim Malone
 19,080 01/18/23

DO HEREBY CERTIFY THAT THIS DOCUMENT HAS BEEN COMPLETED IN ACCORDANCE WITH ACCEPTED ENGINEERING PRACTICES AND IS CORRECT TO THE BEST OF MY KNOWLEDGE AND BELIEF.

ENERGY ENGINEERING SERVICES, PLLC

COMPANY: EAST KENTUCKY NETWORK, LLC
 TOWER SITE: POMP
 TITLE: COW TOWER LOCATION/ELEVATION MAP
 SCALE: 1" = 100'
 DR. BY: TM DATE: 01/18/2023

STATE OF KENTUCKY
COUNTY OF MORGAN

I, **RANDY WILLIAMS**, County Clerk for the County
and State aforesaid, certify that the foregoing
MEMORANDUM OF LEASE was on March 21, 2023 10:18 AM
recorded for record, whereupon the same with the foregoing
and this certificate have been duly recorded in my office.

WITNESS my hand this March 21, 2023
RANDY WILLIAMS, CLERK

By

Jennifer Whitaker

D.C.

Book: 101 Pages: 307-317 (11)
Name: L
RANDY WILLIAMS Deed Tax: \$0.00
MORGAN COUNTY
3/21/2023 10:18 AM
D.C: Jenn



87460

Exhibit 9

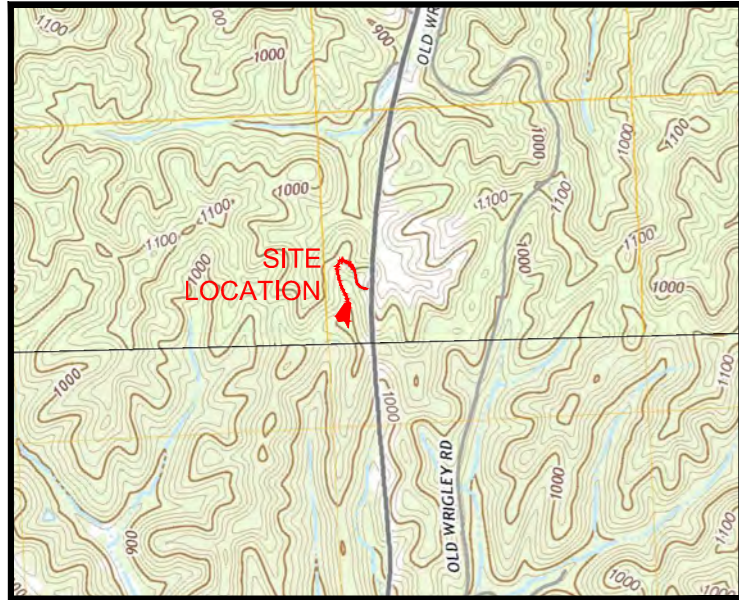

VICINITY MAP

SCALE: 1" = 2000'
A PORTION OF THE WRIGLEY & WEST LIBERTY USGS 7.5' QUADRANGLE MAPS



NORTH ARROW
BEARINGS REFERENCED TO THE
KENTUCKY STATE PLANE
COORDINATE SYSTEM
SOUTH ZONE NAD 83

Cellular Tower
(KY SPCS South Zone NAD83)
Northing: 2256888.74 ft
Easting: 2352918.59 ft
(NAVD 88)
Base Elevation: 1108 ft
LAT: 38° 00' 03.035"
LON: 83° 16' 37.782"

LEGEND

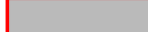
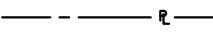
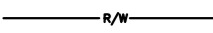
-  PROPOSED TOWER
-  LEASE BOUNDARY LINE
-  BOUNDARY LINE OF PARENT TRACT
-  KY-7 RIGHT OF WAY

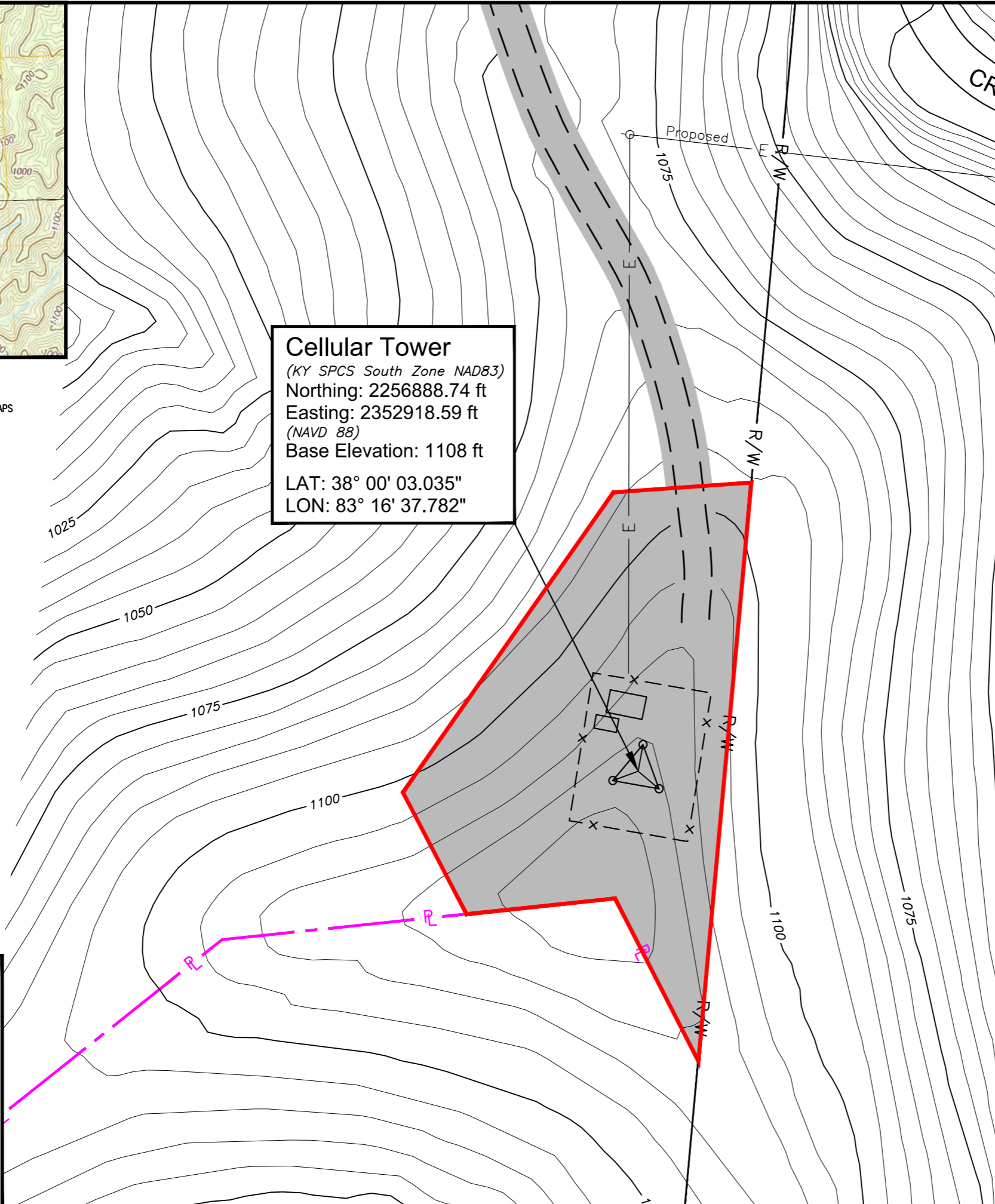

SURVEYOR'S REPORT

THE INTENT OF THE SURVEY DEPICTED HEREON WAS TO SHOW THE DESIGN LOCATION OF THE PROPOSED EAST KENTUCKY NETWORK, LLC CELLULAR TOWER, AS APPLICABLE WITH FAA ORDER 8260.19 G. THIS STRUCTURE SITE IS LOCATED 1.2 MILES SOUTH OF WRIGLEY IN MORGAN COUNTY KENTUCKY.

THE SURVEY USED TO DETERMINE THE LOCATION SHOWN HEREON WAS PERFORMED BY REAL TIME KINEMATIC (RTK) GPS SURVEY METHODS USING TOPCON GR-3 DUAL FREQUENCY RECEIVERS. THE HORIZONTAL AND VERTICAL POSITION OF THE BASE POINT USED TO DETERMINE THE DESIGN POSITION OF THE STRUCTURES SHOWN HEREON WAS BASED ON STATIC GPS SURVEY METHODS, OBSERVED ON 12/22/2022. THE HORIZONTAL DATUM IS NAD 83. THE VERTICAL DATUM IS NAVD 88 WITH FINAL ELEVATIONS DETERMINED BY GEOID18. THE COORDINATES DEPICTED HEREON ARE REFERENCED TO THE KENTUCKY STATE PLANE COORDINATE SYSTEM, SOUTH ZONE, NAD 83. THE DATE OF FINAL SURVEY WAS 12/30/22.

THE ELEVATION CONTOURS SHOWN ARE TAKEN FROM INFORMATION PROVIDED BY THE "KENTUCKY FROM ABOVE" PROGRAM (KYAPED) AND ARE COMPILED FROM AERIAL PHOTOGRAPHY AND ELEVATION DATA (LiDAR) TAKEN DURING THE SPRING OF 2017. THE CONTOUR ELEVATIONS SHOWN ARE BASED UPON THE NAVD 88 DATUM.

THE PROPERTY LINES AND OWNERSHIP INFORMATION SHOWN HEREON ARE BASED UPON RELEVANT MORGAN COUNTY PVA INFORMATION AND DEED RECORDS AS FOUND IN THE MORGAN COUNTY CLERK'S OFFICE, WEST LIBERTY KENTUCKY. THIS MAP IS NOT INTENDED FOR LAND TRANSFER.

THIS SURVEY WAS PERFORMED TO DEMONSTRATE THE DESIGN LOCATION OF THE PROPOSED CELLULAR TOWER, AND IS NOT INTENDED TO BE USED FOR ANY OTHER PURPOSE WHATSOEVER. THE CONTENTS OF THIS MAP ARE TO BE CONSIDERED VALID ONLY IF THE SURVEYOR'S ORIGINAL SIGNATURE AND SEAL ARE APPARENT.

In accordance with FAA Order 8260.19 G, Appendix C, I hereby certify that the proposed tower location information shown hereon meets or exceeds obstacle accuracy standard 2C (+50 feet Horizontal and +20 feet vertical).

01/03/23

TIM MALONE, PLS #3480
SYNERGY ENGINEERING SERVICES, PLLC
611 HAMBLEY BLVD, SUITE #3
PIKEVILLE, KY 41501
(606) 433-0336

DATE: 01/03/23

STATE of KENTUCKY

TIM MALONE
3480

LICENSED
PROFESSIONAL
LAND SURVEYOR



GRAPHIC SCALE 1" = 50'

SE SYNERGY ENGINEERING SERVICES, PLLC
611 HAMBLEY BLVD, SUITE #3, PIKEVILLE, KY 41501
PHONE: (606) 433-0336 FAX: 433-0363

OBSTACLE DATA LOCATION MAP (2C Map)

FOR
EAST KENTUCKY NETWORK, LLC
dba Appalachian Wireless
101 TECHNOLOGY TRAIL, IVEL KY 41642

SHOWING A PROPOSED CELLULAR TOWER SITE LOCATED AT
Wrigley Elementary School near Pomp, KY
3 miles North of the Intersection of KY 7 & KY 1161

SCALE : 1" = 50'

DRAWN BY : ZM

LAST REVISION DATE : 1/2/23

CHECKED BY: TM

Exhibit 10

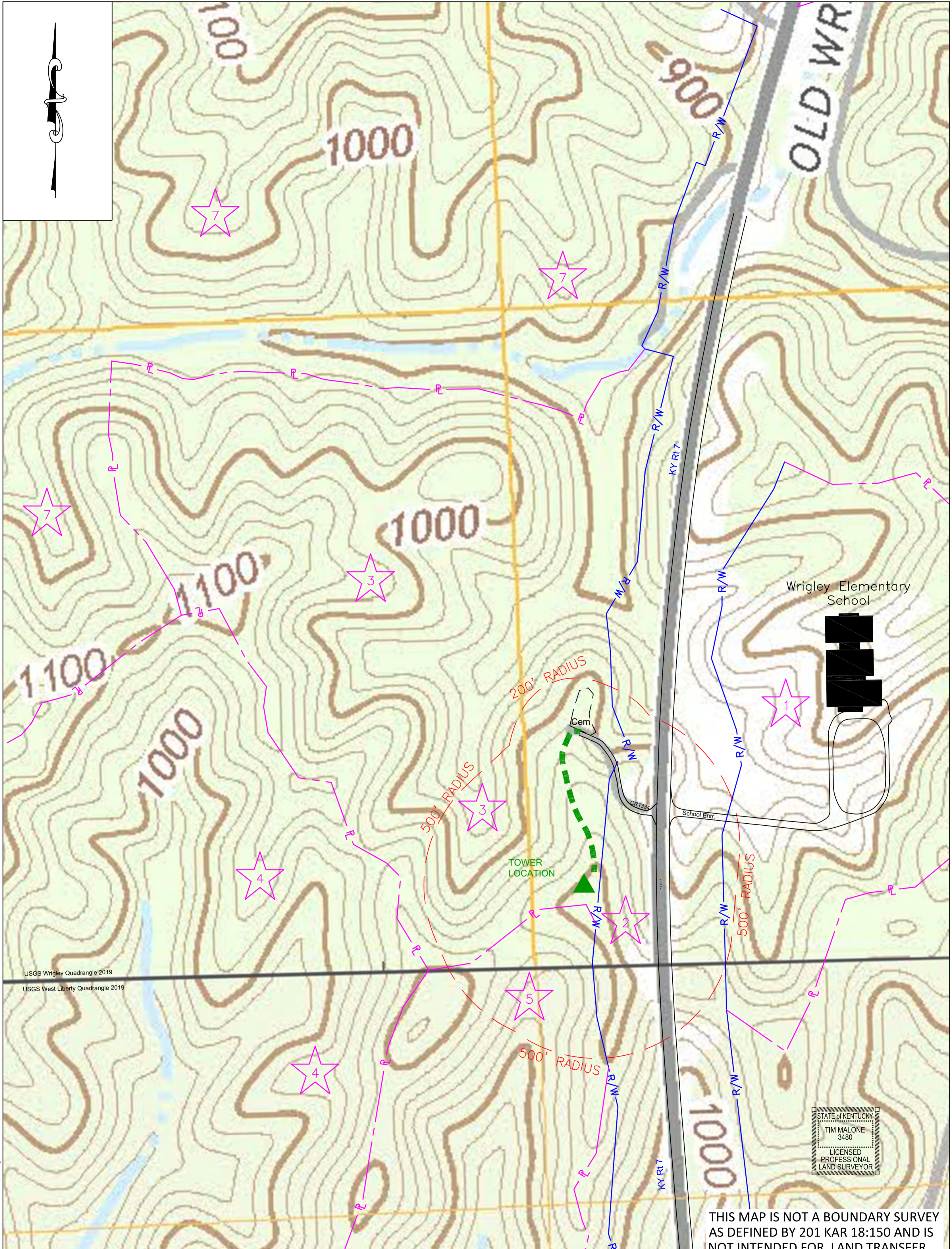

USGS Wrigley Quadrangle 2019
 USGS West Liberty Quadrangle 2019

STATE OF KENTUCKY
 TIM MALONE
 3480
 LICENSED
 PROFESSIONAL
 LAND SURVEYOR

THIS MAP IS NOT A BOUNDARY SURVEY
 AS DEFINED BY 201 KAR 18:150 AND IS
 NOT INTENDED FOR LAND TRANSFER.

TRACT NO.	SURFACE OWNER	ADDRESS	PVA NUMBER
★	Morgan County School District Finance Corp.	PO Box 489 West Liberty, KY 41472	102-00-00-027.01
★	Commonwealth of Kentucky	KYDOT District 10 473 KY Route 15 Jackson, KY 41339	No PVA Number Available
★	Darrell Patrick	93 HWY 1002 West Liberty, KY 41472	102-00-00-027.00
★	David and Lynn Phipps	5429 HWY 191 West Liberty, KY 41472	085-00-00-018.01
★	Robert and Dorothy Caskey	4362 Filly Lane Destin, FL 32541	085-00-00-009.00
★	Wendell and Sharon Bradley	7109 HWY 7 West Liberty, KY 41472	103-00-00-001.01
★	Jerry Whitt	7977 HWY 7 West Liberty, KY 41472	084-00-00-014.00

0' 200' 400'
 SCALE: 1" = 200'

SYNERGY ENGINEERING SERVICES, PLLC
 COMPANY: EAST KENTUCKY NETWORK LLC
 APP. NO.:
 TITLE: POMP TOWER PROPERTY OWNER MAP
 SCALE: 1" = 200'
 DR. BY: ZM DATE: 02/16/24

PVA Property Exhibit
 This map shows the general property line locations and owner information based upon Morgan County PVA data. This map is intended to show the proposed tower and access road locations relative to the PVA property lines and owners, in accordance with 807 KAR 5:063 Section 1(1)(i).

Tim Malone
 3480 02/26/24
 PLS DATE

H:\CurrentProjects\Approach\releas\pomp\ekn\pomp_tower_workmap6.dwg

Exhibit 11

POMP TOWER
VERTICAL PROFILE SKETCH

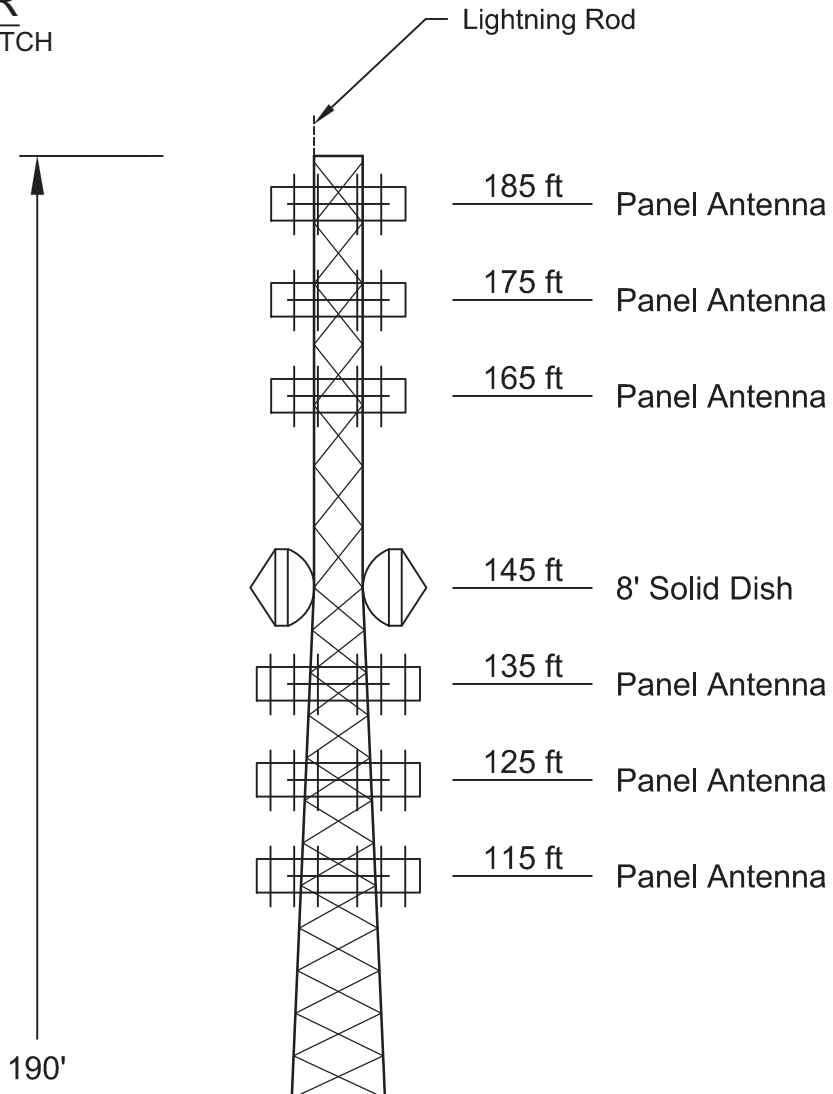

Note: This drawing is a sketch showing the vertical placement of the antenna and dish elements on the proposed tower. This drawing does not certify any portion of the structural design of the tower or foundation portions of the structure. The dimensions of the tower base and foundation may vary depending upon the tower manufacturer.

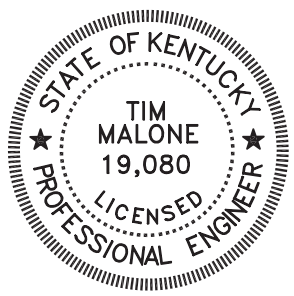

Tower Base El. 1108'

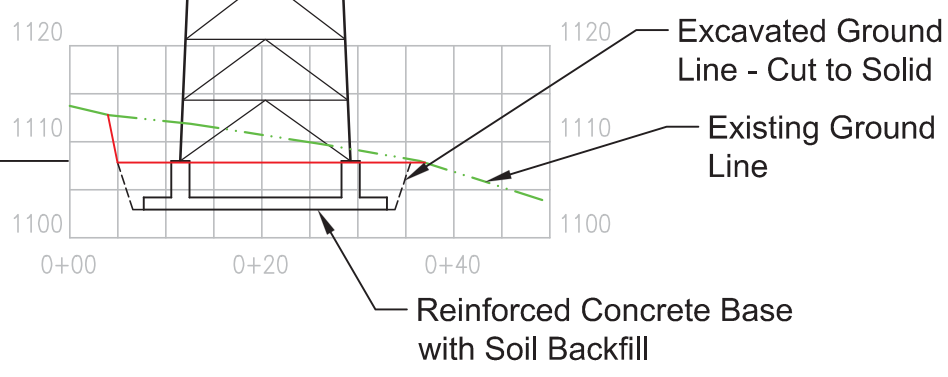

Tim Malone PE, PLS
Synergy Engineering Services, PLLC
611 Hambley Blvd, Suite #3
Pikeville, KY 41501
(606) 433-0336

SYNERGY ENGINEERING SERVICES, PLLC

EAST KENTUCKY NETWORK LLC
COMPANY: dba APPALACHIAN WIRELESS

TITLE: POMP TOWER VERTICAL PROFILE

SCALE: 1" = 20'

DR. BY: TM DATE: 04/02/24

ATTACHMENT NO.:

Tim Malone
I, Tim Malone, 19,080, 04/02/24
DO HEREBY CERTIFY THAT THIS DOCUMENT HAS BEEN COMPLETED IN ACCORDANCE WITH ACCEPTED ENGINEERING PRACTICES AND IS CORRECT TO THE BEST OF MY KNOWLEDGE AND BELIEF.

H:\-curr-mtPr-j-ts\A\j-ll-hi-mWir-l-s-\P-mj\T-w_r_V_rti-llPr-fil-.lwj

Exhibit 12

Utility ID	Utility Name	Utility Type	Class	City	State
4107900	365 Wireless, LLC	Cellular	D	Atlanta	GA
4109300	Access Point, Inc.	Cellular	D	Cary	NC
4108300	Air Voice Wireless, LLC	Cellular	A	Bloomfield Hill	MI
4110650	Alliant Technologies of KY, L.L.C.	Cellular	C	Morristown	NJ
44451184	Alltel Communications, LLC	Cellular	A	Basking Ridge	NJ
4110850	AltaWorx, LLC	Cellular	C	Fairhope	AL
4107800	American Broadband and Telecommunications Company	Cellular	C	Toledo	OH
4108650	AmeriMex Communications Corp.	Cellular	D	Dunedin	FL
4105100	AmeriVision Communications, Inc. d/b/a Affinity 4	Cellular	D	Virginia Beach	VA
4110700	Andrew David Balholm dba Norcell	Cellular	C	Clayton	WA
4108600	BCN Telecom, Inc.	Cellular	D	Morristown	NJ
4110550	Blue Casa Mobile, LLC	Cellular	D	Santa Barbara	CA
4108750	Blue Jay Wireless, LLC	Cellular	C	Carrollton	TX
4111050	BlueBird Communications, LLC	Cellular	C	New York	NY
4202300	Bluegrass Wireless, LLC	Cellular	A	Elizabethtown	KY
4107600	Boomerang Wireless, LLC	Cellular	B	Hiawatha	IA
4105500	BullsEye Telecom, Inc.	Cellular	D	Southfield	MI
4110050	CampusSims, Inc.	Cellular	D	Boston	MA
4100700	Cellco Partnership dba Verizon Wireless	Cellular	A	Basking Ridge	NJ
4106600	Cintex Wireless, LLC	Cellular	D	Rockville	MD
4111000	ComApp Technologies LLC	Cellular	C	Melrose	MA
4101900	Consumer Cellular, Incorporated	Cellular	A	Portland	OR
4106400	Credo Mobile, Inc.	Cellular	A	San Francisco	CA
4108850	Cricket Wireless, LLC	Cellular	A	San Antonio	TX
4001900	CTC Communications Corp. d/b/a EarthLink Business I	Cellular	D	Grand Rapids	MI
10640	Cumberland Cellular Partnership	Cellular	A	Elizabethtown	KY
4101000	East Kentucky Network, LLC dba Appalachian Wireless	Cellular	A	Ivel	KY
4002300	Easy Telephone Service Company dba Easy Wireless	Cellular	D	Ocala	FL
4109500	Enhanced Communications Group, LLC	Cellular	D	Bartlesville	OK
4110450	Excellus Communications, LLC	Cellular	D	Chattanooga	TN
4105900	Flash Wireless, LLC	Cellular	C	Concord	NC
4104800	France Telecom Corporate Solutions L.L.C.	Cellular	D	Oak Hill	VA
4109350	Global Connection Inc. of America	Cellular	D	Norcross	GA
4102200	Globalstar USA, LLC	Cellular	B	Covington	LA
4109600	Google North America Inc.	Cellular	A	Mountain View	CA
33350363	Granite Telecommunications, LLC	Cellular	D	Quincy	MA
4106000	GreatCall, Inc. d/b/a Jitterbug	Cellular	A	San Diego	CA
10630	GTE Wireless of the Midwest dba Verizon Wireless	Cellular	A	Basking Ridge	NJ
4110600	Horizon River Technologies, LLC	Cellular	C	Atlanta	GA
4103100	i-Wireless, LLC	Cellular	A	Newport	KY
4109800	IM Telecom, LLC d/b/a Infiniti Mobile	Cellular	D	Tulsa	OK
22215360	KDDI America, Inc.	Cellular	D	New York	NY
10872	Kentucky RSA #1 Partnership	Cellular	A	Basking Ridge	NJ
10680	Kentucky RSA #3 Cellular General	Cellular	A	Elizabethtown	KY
10681	Kentucky RSA #4 Cellular General	Cellular	A	Elizabethtown	KY
4109750	Konatel, Inc. dba telecom.mobi	Cellular	D	Johnstown	PA
4110900	Lunar Labs, Inc.	Cellular	C	Detroit	MI
4107300	Lycamobile USA, Inc.	Cellular	D	Newark	NJ
4108800	MetroPCS Michigan, LLC	Cellular	A	Bellevue	WA
4109650	Mitel Cloud Services, Inc.	Cellular	D	Mesa	AZ
4202400	New Cingular Wireless PCS, LLC dba AT&T Mobility, PCS	Cellular	A	San Antonio	TX
10900	New Par dba Verizon Wireless	Cellular	A	Basking Ridge	NJ
4000800	Nextel West Corporation	Cellular	D	Overland Park	KS
4001300	NPCR, Inc. dba Nextel Partners	Cellular	D	Overland Park	KS

4001800	OnStar, LLC	Cellular	A	Detroit	MI
4110750	Onvoy Spectrum, LLC	Cellular	C	Plymouth	MN
4109050	Patriot Mobile LLC	Cellular	D	Southlake	TX
4110250	Plintron Technologies USA LLC	Cellular	D	Bellevue	WA
33351182	PNG Telecommunications, Inc. dba PowerNet Global Communications	Cellular	D	Cincinnati	OH
4202100	Powertel/Memphis, Inc. dba T-Mobile	Cellular	A	Bellevue	WA
4107700	Puretalk Holdings, LLC	Cellular	A	Covington	GA
4106700	Q Link Wireless, LLC	Cellular	A	Dania	FL
4108700	Ready Wireless, LLC	Cellular	B	Hiawatha	IA
4110500	Republic Wireless, Inc.	Cellular	D	Raleigh	NC
4111100	ROK Mobile, Inc.	Cellular	C	Culver City	CA
4106200	Rural Cellular Corporation	Cellular	A	Basking Ridge	NJ
4108550	Sage Telecom Communications, LLC dba TruConnect	Cellular	D	Los Angeles	CA
4109150	SelecTel, Inc. d/b/a SelecTel Wireless	Cellular	D	Freemont	NE
4106300	SI Wireless, LLC	Cellular	A	Carbondale	IL
4110150	Spectrotel, Inc. d/b/a Touch Base Communications	Cellular	D	Neptune	NJ
4200100	Sprint Spectrum, L.P.	Cellular	A	Atlanta	GA
4200500	SprintCom, Inc.	Cellular	A	Atlanta	GA
4109550	Stream Communications, LLC	Cellular	D	Dallas	TX
4110200	T C Telephone LLC d/b/a Horizon Cellular	Cellular	D	Red Bluff	CA
4202200	T-Mobile Central, LLC dba T-Mobile	Cellular	A	Bellevue	WA
4002500	TAG Mobile, LLC	Cellular	D	Carrollton	TX
4109700	Telecom Management, Inc. dba Pioneer Telephone	Cellular	D	South Portland	ME
4107200	Telefonica USA, Inc.	Cellular	D	Miami	FL
4108900	Telrite Corporation dba Life Wireless	Cellular	D	Covington	GA
4108450	Tempo Telecom, LLC	Cellular	D	Kansas City	MO
4109950	The People's Operator USA, LLC	Cellular	D	New York	NY
4109000	Ting, Inc.	Cellular	A	Toronto	ON
4110400	Torch Wireless Corp.	Cellular	D	Jacksonville	FL
4103300	Touchtone Communications, Inc.	Cellular	D	Whippany	NJ
4104200	TracFone Wireless, Inc.	Cellular	D	Miami	FL
4002000	Truphone, Inc.	Cellular	D	Durham	NC
4110300	UVNV, Inc.	Cellular	D	Costa Mesa	CA
4105700	Virgin Mobile USA, L.P.	Cellular	A	Atlanta	GA
4110800	Visible Service LLC	Cellular	C	Lone Tree	CO
4106500	WiMacTel, Inc.	Cellular	D	Palo Alto	CA
4110950	Wing Tel Inc.	Cellular	C	New York	NY
4109900	Wireless Telecom Cooperative, Inc. dba theWirelessFreeway	Cellular	D	Louisville	KY

Exhibit 13

S & S Tower Services
120 Branden Dr.
Mousie, KY 41839

Kentucky Public Service Commission
211 Sower Blvd.
P.O. Box 615
Frankfort, KY 40602-0615

Dear Commissioners:

The Construction Manager for the proposed communications facility will be Dave Strausbaugh. His contact information is (606) 497-6730 or dstrausbaugh010@gmail.com.

Dave has been in the industry completing civil construction and constructing towers since 1991. He has worked for S&S Tower Services since 2015 as Construction Manager overseeing the construction of telecommunications towers and sites.

Thank you,

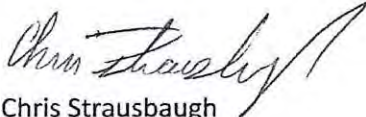

Chris Strausbaugh
Owner
S&S Tower Services
(606) 497-5798

General Company Information

World Tower Company, Inc. is located at 1213 Compressor Drive in Mayfield, Kentucky. Our mailing address is PO Box 508, Mayfield KY 42066. You may reach our offices at V - 270-247-3642, F - 270-247-0909, or E-Mail us at worldtower@tdt.net. Our website may be visited at www.worldtower.com

The company was established in 1959 as eastern division manufacturing of Utility Tower. The company became World Tower Company, Inc. in 1979. At which time designs were changed from pipe to total solid rod towers. Due to increase in volume and a need for more capacity, World Tower Company moved manufacturing and offices to a new facility in 1997. World Tower Company manufactures all solid rod guyed and self-supporting towers. We are able to fabricate guyed towers to 1200' and self-supporting towers to 500'.

Guyed towers make up about 40% percent of the company's total production. Sixty percent of our production output is in self-supporting towers.

World Tower Company, Inc. is wholly owned and not a member of a partnership of consortium

Account Management

Doug Walker is President of World Tower Company. Doug takes a hands-on approach to the business. He is involved in sales, design and customer relations. The Secretary/Treasurer of the company is Danette Rowe. Danette serves the company as office manager. She oversees the office operations and is responsible for accounting for the business. Kirk Hall P.E. oversees World Tower's Engineering Department. Kirk has much experience in the tower industry.

A weekly production meeting with all responsible supervisory personnel is held each Tuesday to update production schedules. Following that meeting a detailed report can be generated to our customers as to the exact status of their order. Reports are provided only at customers request.

Quality/Customer Service

World Tower Company requires that all welded material be inspected prior to loading. One (1) face of all self-supporting towers is assembled to ensure proper fit prior to being galvanized. An on-site inspection is performed at the galvanizing plant prior to

galvanizing. All material is once again inspected following the galvanizing process. Our truck driver must inspect each load before loading at galvanizing plant. All loads are again inspected by driver and notated on delivery sheet following off loading. A customer representative must be on site to inspect and accept material when off loaded (unless waived by customer).

World Tower Self-Supporting System

For restricted space requirements, World Tower offers a versatile and self-supporting tower system. No guy wires are necessary and each tower is fabricated using a solid leg with angled cross members for a sound, secure tower. Each system can vary in face width, which depends on site space. In addition, World Tower offers a maximum height of their self-supporter at approximately 500 feet depending on tower loading.

Choose World Tower's Self Supporting system for the security of life-long usage for your communications systems.

Self-Supporting Systems:

- Stable, rigid construction
 - Pre-assembled before Delivery
 - Minimal space requirements
 - Multiple application usage
 - Solid rod legs with angled cross members
- Retrofitting for future loading