

INFRASTRUCTURE IMPROVEMENT PLAN for the UNACCOUNTED-FOR WATER LOSS REDUCTION PLAN

CUMBERLAND COUNTY WATER DISTRICT DECEMBER 2024

The Cumberland County Water District (CCWD) is in the process of implementing their Infrastructure Improvement Plan for the Unaccounted-For Water Loss Reduction Plan (Plan). The Plan consists of replacing ten (10) existing zone meters, purchasing and installing eighteen (18) new cellular antennas at each existing zone meter, replacing existing aged meters with new radio read meters and antennas, and purchasing a new drive-by radio reader for residential meters. The District will purchase initially 119 new residential radio read meters and antennas and then 29 new residential radio meters and antennas each month thereafter until the 48th month. In the 48th month, the District will purchase another 30 new residential radio read meters and antennas should enough funds be available.

CCWD operates a potable water system that serves all of Cumberland County, with the exception of the City of Burkesville, and also serves a few customers in Clinton, Metcalfe, and Monroe Counties. According to the Kentucky Infrastructure Authority's (KIA) Water Resource Information System (WRIS), Asset Inventory Report, the water system consists of approximately 306 miles of water lines that range in size from 3-inch diameter to 8-inch diameter, and according to KIA's WRIS System Data Report, CCWD has a Connection Count of 2,954 meters which consists of 2,306 Serviceable Households with a Serviceable Population of 3,953 people. Most of the customers are residential users. The KIA's WRIS Asset Inventory Report is in Appendix 1 and the KIA's WRIS System Data Report is in Appendix 2.

CCWD utilizes a radio read metering system throughout their entire system that allows for instantaneous meter readings via the drive by method. The installation of the radio read meters was initiated in 2009 and was completed in 2011. Since that time CCWD has worked toward replacing meters that are inaccurate or over ten years in service and a typical record of this activity is contained in a Quarterly Meter Report and kept on file. A copy of the most recent Quarterly Meter Report for the third quarter of 2024 is in Appendix 3.

In addition, CCWD has divided their water system into 12 zones that are currently monitored by 18 zone meters. Four of the zone meters are at supply purchase points of which three are owned and operated by the City of Burkesville and one is owned and operated by the City of Albany. The remaining 14 zone meters are owned and operated by CCWD and are located strategically throughout their water system. The meters have been in service for over or approaching ten years and a portion are scheduled to be replaced and upgraded through the water surcharge program. These meters are read on a daily basis of which monthly readings are compared to the customer service meter readings to determine water loss and are also used to monitor trends in day-to-day demand. A Master Meter List is attached, and it lists the Zone where the meter is located and its referred Master Meter name along with the size of the meter. In addition is a map of the water system that indicates the individual zones and their boundaries.

The new master meter shall be manufactured by the Neptune Technology Group, and it shall be an ultrasonic meter in accordance with their Mach 10 model, or an approved equal. It shall have the capability of Advanced Metering Infrastructure (AMI) which is a communication network and data management system that enables two-way communication between the meter end points and CCWD. Unlike the drive by method of meter reading that CCWD uses for its service meters, the new zone master meter will transmit meter readings directly to CCWD at predetermined intervals via a cellular system. A copy of their product literature is in Appendix 4

According to their Annual Report for the calendar year 2023, and on file at the Kentucky Public Service Commission (PSC), for that year CCWD purchased 226,675,000 gallons of water and had unaccounted for water loss of 86,429,000 gallons of water which calculates to an unaccounted-for water loss of 38.129 percent. In addition, CCWD compiles water loss on a monthly basis in the form of a Monthly Water Loss Report. An excerpt from the Annual Report and CCWD's Monthly Water Loss Reports for the period of January 2024 through November 2024 are shown in Appendix 5.

On October 5, 2023, PSC authorized CCWD to assess a monthly water surcharge of \$2.85 per active meter for 48 months, or until \$386,460 has been assessed, whichever occurs first, to fund its unaccounted-for water loss reduction efforts.

The Plan consists of replacing ten (10) of the existing master meters with new master meters and installing eighteen (18) new cellular antennas at each of the existing zone meters. All of the existing zone meters are either or approaching 10 years in age and they are to be replaced. The zone meters will be read in conjunction with the reading of the service meters. The comparison of the readings of the zone meters versus the service meters will allow CCWD to determine the water loss in each zone. A map of the water system with the breakdown of the current zones and the existing zone meters is posted in the CCWD's office.

The Plan also consists of the purchase and replacement of 1,135 residential radio read meters that are known to be either over or approaching 10 years in service.

In determining the amount of the surcharge that is collected each month, the number of customers used to determine the month surcharge was taken from the latest Quarterly Meter Report for the period of July – September 2024, and that number was 2,872 customers. Applying the surcharge amount of \$2.85 per customer equates to a surcharge collection total of \$8,185.45 per month and over a 48-month period that cumulative total is \$392,889.60. This amount is slightly higher than the amount as shown in the PSC’s Order for Case Number 2023-00228 regarding the surcharge, that amount being \$386,460.

In order to implement the Plan, attached is a Preliminary Cost Estimate that lists the items to be addressed along with the quantity of each item and their respective cost. The first item consists of purchasing and installing a new cellular antenna at each or the existing zone master meters. The next three items consist of the replacement of the existing zone master meters. This work is planned to be performed by an outside contractor. The fifth item consists of the one-time set up fee and training fees for the new master meters and cellular antennas by Neptune (NECO) Solutions. Item six will consist of the purchase of a new drive-by radio reader for residential meters. Item seven will consist of an annual fee for services and data plan performed by Neptune (NECO) Solutions. Item eight consists of the purchasing and replacing 1,135 existing meters with new radio read meters as manufactured by Diehl Metering, LLC and Neptune antennas.

A Detailed Spending Plan is attached, and it outlines a monthly schedule to perform the improvements and lists the activity and its cost. The CCWD has begun the collection of the surcharge for the first twelve months with the first month starting December 2023. In month 13, CCWD plans to purchase eighteen (18) new cellular antennas to be installed at each existing zone meter locations. Along with the purchase of the antennas will come a one-time set-up and training fee and an annual service fee. The annual service fee will be repeated in months, 24, 36, and 48. During month 13, CCWD will install the zone meter antennas, purchase new master meters to replace ten (10) existing master meters and install them in months 14 through 17. The master meters will consist of replacing nine (9) of the existing 4-inch master meters at the following meter zones: Burkesville South 61, Albany, South 61 North, Sulphur Creek, South 61 West, Marrowbone 90 East, Marrowbone 90 West, North 61 (Garret Creek), and Highway 704, and one (1) existing 3-inch master meter at zone meter, Highway 1880. In addition, CCWD will purchase 119 residential meters with cellular antennas during month 13 and install them in months 14 through 17. For the months beginning 14 through 47, CCWD will purchase 29 residential meters and antennas each month, installing them in months 15 through 48. To close out the Plan, the CCWD will purchase and install approximately 30 residential meters that will take place in months 48 and 49.

A Cash Flow Plan is also attached, and it outlines the current collected surcharge (highlighted in blue) for the first twelve (12) months, starting December 2023, surcharge collected each month thereafter until the month 48, expenses, and a running cash flow so that the expenses don’t exceed the amount collected from the surcharge.

A list of Attachments is as follows:

- Appendix 1: Kentucky Infrastructure Authority's Water Resource Information System Asset Inventory Report
- Appendix 2: Kentucky Infrastructure Authority's Water Resource Information System Data Report
- Appendix 3: Quarterly Meter Report
- Appendix 4: Diehl Hydrus Meter and Neptune (NECO) Antenna Specifications
- Appendix 5: Annual Report & Monthly Water Loss Report

CUMBERLAND COUNTY WATER DISTRICT

MASTER METER LIST

	ZONE	MASTER METER	SIZE (INCH)	NOTES
1	MARROWBONE	HIGHWAY 90 *EAST/*WEST	4 & 4	TWO METERS
2	NORTH 61	*GARRETT CREEK	4	
3	WEST FORK	*HIGHWAY 704	4	
4	WATER PLANT	*BURKESVILLE / SOUTH 61	4	PURCHASE METER
5		WATER PLANT	6	
6	HIGHWAY 1880	*NEW 1880 PS	3	
7		BURKESVILLE / CEDAR CK	3	PURCHASE METER
8	SOUTH 61	*SOUTH 61 WEST	4	HWY 953
9		*SOUTH 61 NORTH	4	JOE SCOTT
10	WHITES BOTTOM	WHITES BOTTOM	2	
11	SULPHUR CREEK	*SULPHUR CREEK	4	
12	ASHLOCK	ASHLOCK	2	BILLY COOT
13	SOUTH 61 EAST	SOUTH 61 EAST	2	JAMES LONG
14	ALBANY / HWY 449	*ALBANY	4	PURCHASE METER
15		BURKESVILLE / ZINC MINE	3	PURCHASE METER
16	HIGHWAY 1206	HIGHWAY 1206	4	
17		STATE PARK	3	

*MASTER METERS TO BE REPLACED

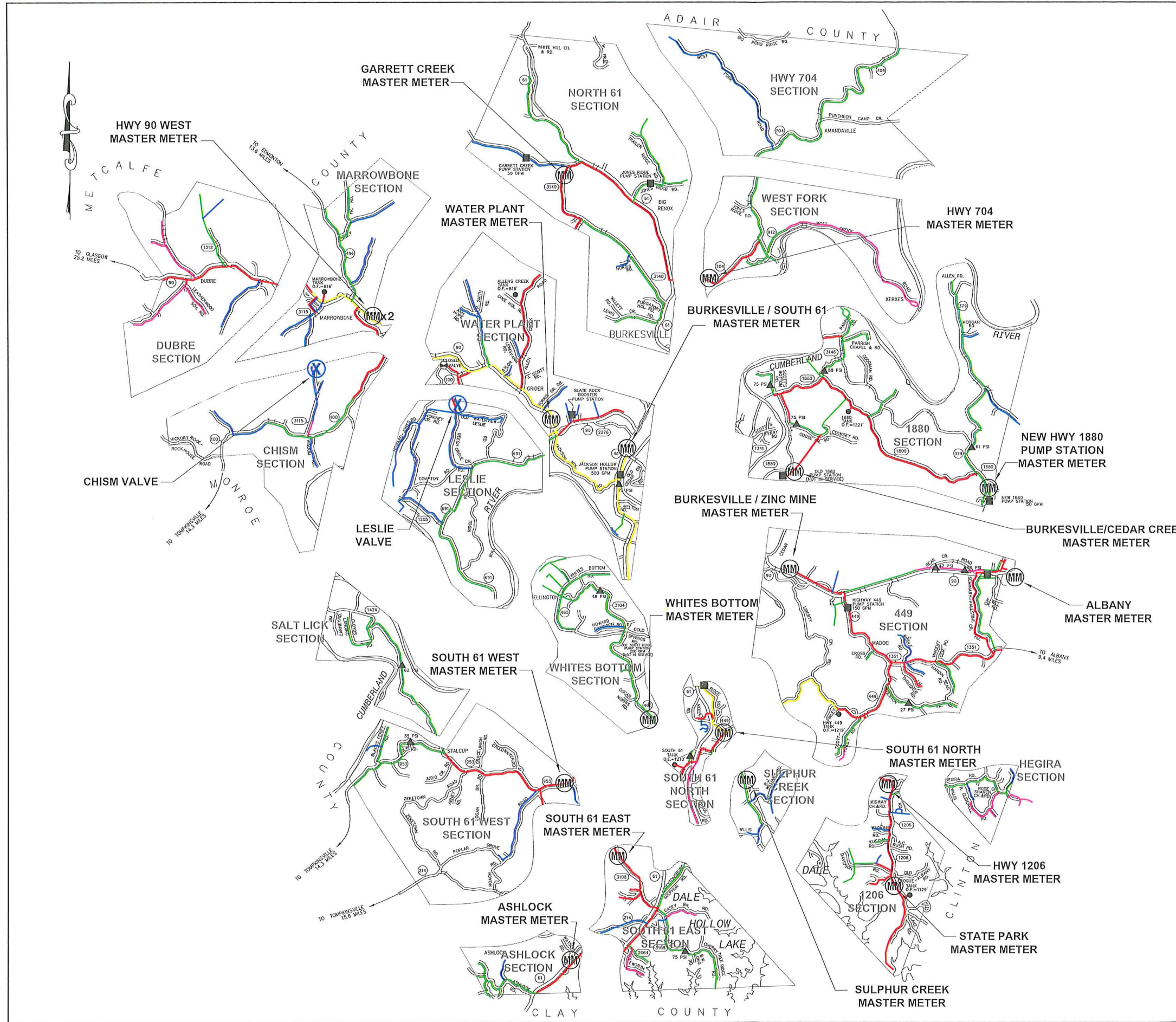

WATER LINE LAYOUT
LEGEND

	2 INCH WATER LINE		EXISTING MASTER METER
	3 INCH WATER LINE		CLOSED VALVE
	4 INCH WATER LINE		MASTER METER ZONE
	6 INCH WATER LINE		
	8 INCH WATER LINE		
	TANK SITE		
	PUMP STATION		
	PRESSURE REDUCING STATION		
	MASTER METER		

WATER SYSTEM
CUMBERLAND COUNTY WATER DISTRICT
CUMBERLAND COUNTY, KENTUCKY

MASTER METER ZONE MAP WITH PROPOSED NEW MASTER METERS

M
Monarch Engineering, Inc.

556 CARLTON DRIVE
LAWRENCEBURG, KY 40342

DRAWN BY: JLM	DATE: JANUARY 2024	REVISED	SHEET
CHECKED BY: DSB	SCALE: 3/16"=1 MILE		
CHECKED BY: DMB	PROJECT NO: 2372		

**DETAILED SPENDING PLAN
for the
UNACCOUNTED-FOR WATER LOSS
REDUCTION PLAN**

**CUMBERLAND COUNTY WATER DISTRICT
DECEMBER 2024**

***Month 1 Surcharge Collected: December 2023**

MONTH	ACTIVITY	COST
1-12	Surcharges Collected to Date.	
13	Purchase eighteen (18) Antennas for Existing Master Meter Locations including Set-up and Training Fees.	\$7,276.00
13	Annual Fee for Radio Read/Antenna Services	652.50
13	Purchase eight (8) 4-Inch x 14 New Master Meters, one (1) 4-Inch x 20 New Master Meter, one (1) 3-Inch x 12 New Master Meter, and one (1) New Drive By Radio Reader for Residential Meters.	45,010.00
13	Purchase 119 New Residential Meters and Antennas	34,034.00
14-17	Install New Antennas on eighteen(18) Existing Master Meter locations, Install eight (8) 4-Inch x 14 Master Meters, one (1) 4-Inch x 20 Master Meter, one (1) 3-Inch x 12 Master Meter, and Install 119 Residential Meters.	
14-47	Purchase 29 Radio Read Residential Meters & Antennas per Month	281,996.00
15-48	Install 1,016 Radio Read Residential Meters & Aetennas	
24	Annual Fee for Radio Read/Antenna Services	652.50
36	Annual Fee for Radio Read/Antenna Services	652.50
48	Annual Fee for Radio Read/Antenna Services	652.50
48	Purchase 30 new Radio Read Residential Meters and Antennas	8,580.00
49	Install 30 Radio Read Residential Meters and Antennas	
	TOTAL EXPENSE	\$379,506.00

CASH FLOW PLAN
for the
UNACCOUNTED-FOR WATER LOSS
REDUCTION PLAN

CUMBERLAND COUNTY WATER DISTRICT
DECEMBER 2024

***Month 1: December 2023 - Surcharge Collection**

MONTH	COLLECTED SURCHARGE	EXPENSES	CASH FLOW
1*	\$6,372.83	\$0.00	\$6,372.83
2	\$7,502.24	\$0.00	\$13,875.07
3	\$7,489.00	\$0.00	\$21,364.07
4	\$7,396.75	\$0.00	\$28,760.82
5	\$7,306.23	\$0.00	\$36,067.05
6	\$7,127.40	\$0.00	\$43,194.45
7	\$7,363.99	\$0.00	\$50,558.44
8	\$7,238.21	\$0.00	\$57,796.65
9	\$8,014.20	\$0.00	\$65,810.85
10	\$8,014.20	\$0.00	\$73,825.05
11	\$7,354.12	\$0.00	\$81,179.17
12	\$7,354.12	\$0.00	\$88,533.29
13	\$8,085.45	\$86,972.50	\$9,646.24
14	\$8,085.45	\$8,294.00	\$9,437.69
15	\$8,085.45	\$8,294.00	\$9,229.14
16	\$8,085.45	\$8,294.00	\$9,020.59
17	\$8,085.45	\$8,294.00	\$8,812.04
18	\$8,085.45	\$8,294.00	\$8,603.49
19	\$8,085.45	\$8,294.00	\$8,394.94
20	\$8,085.45	\$8,294.00	\$8,186.39
21	\$8,085.45	\$8,294.00	\$7,977.84
22	\$8,085.45	\$8,294.00	\$7,769.29
23	\$8,085.45	\$8,294.00	\$7,560.74
24	\$8,085.45	\$8,946.50	\$6,699.69
25	\$8,085.45	\$8,294.00	\$6,491.14
26	\$8,085.45	\$8,294.00	\$6,282.59
27	\$8,085.45	\$8,294.00	\$6,074.04
28	\$8,085.45	\$8,294.00	\$5,865.49
29	\$8,085.45	\$8,294.00	\$5,656.94
30	\$8,085.45	\$8,294.00	\$5,448.39
31	\$8,085.45	\$8,294.00	\$5,239.84
32	\$8,085.45	\$8,294.00	\$5,031.29
33	\$8,085.45	\$8,294.00	\$4,822.74

**CASH FLOW PLAN
for the
UNACCOUNTED-FOR WATER LOSS
REDUCTION PLAN**

**CUMBERLAND COUNTY WATER DISTRICT
DECEMBER 2024**

***Month 1: December 2023 - Surcharge Collection**

MONTH	COLLECTED SURCHARGE	EXPENSES	CASH FLOW
34	\$8,085.45	\$8,294.00	\$4,614.19
35	\$8,085.45	\$8,294.00	\$4,405.64
36	\$8,085.45	\$8,946.50	\$3,544.59
37	\$8,085.45	\$8,294.00	\$3,336.04
38	\$8,085.45	\$8,294.00	\$3,127.49
39	\$8,085.45	\$8,294.00	\$2,918.94
40	\$8,085.45	\$8,294.00	\$2,710.39
41	\$8,085.45	\$8,294.00	\$2,501.84
42	\$8,085.45	\$8,294.00	\$2,293.29
43	\$8,085.45	\$8,294.00	\$2,084.74
44	\$8,085.45	\$8,294.00	\$1,876.19
45	\$8,085.45	\$8,294.00	\$1,667.64
46	\$8,085.45	\$8,294.00	\$1,459.09
47	\$8,085.45	\$8,294.00	\$1,250.54
48	\$8,085.45	\$9,232.50	\$103.49
TOTAL	\$379,609.49	\$379,506.00	

**PRELIMINARY COST ESTIMATE
 WATER LOSS REDUCTION PLAN
 CUMBERLAND COUNTY WATER DISTRICT
 DECEMBER 2024**

1	Purchase & Install NECO Solutions Cellular Antennas at each Master Meter Locations	18 EA	182.00	3,276.00
TOTAL				\$3,276.00

Item No.	Description	Quantity	Unit Price	Total Cost
2	Purchase & Replace 4-Inch Master Meter with New 4-Inch x 14 Ultrasonic Meter	8 EA	\$3,455.00	\$27,640.00
3	Purchase & Replace 4-Inch Master Meter with New 4-Inch x 20 Ultrasonic Meter	1 EA	3,565.00	3,565.00
4	Purchase & Replace 3-Inch Master Meter with New 3-Inch x 12 Ultrasonic Meter	1 EA	2,870.00	2,870.00
5	One Time Set Up & Training Fee	1 LS	4,000.00	4,000.00
6	Drive By Radio Reader for Residential Meters	1 LS	10,935.00	10,935.00
7	Annual Fee for NECO Solutions Services & Data Plan	4 YR	652.50	2,610.00
TOTAL				\$51,620.00

8	Purchase & Replace Existing 3/4-Inch Service Meter w/ New 3/4-Inch Diehl Radio Read Meter	1,135 EA	136.00	154,360.00
	Purchase & Install Residential Cellular Antennas by NECO	1,135 EA	150.00	170,250.00
TOTAL				\$324,610.00

**PRELIMINARY COST ESTIMATE
WATER LOSS REDUCTION PLAN
CUMBERLAND COUNTY WATER DISTRICT
DECEMBER 2024**

PROJECT COSTS

MASTER METERS & CELLULAR ANTENNAS	\$37,351
TRAINING AND SET UP FEE	4,000
ANNUAL SERVICE FEE	2,610
RADIO READ DRIVE BY READER	10,935
SERVICE METER REPLACEMENT	<u>324,610</u>
TOTAL PROJECT COST	\$379,506.00

PROJECT FINANCING

CUMBERLAND COUNTY WATER DISTRICT WATER LOSS REDUCTION SURCHARGE	<u>\$386,460</u>
TOTAL PROJECT FINANCING	\$386,460.00

APPENDIX 1

WRIS Asset Inventory Report

KY0290271 - Cumberland County Water District

Rating Code	Condition Rating	Performance Rating	Priority Rating
0			Not a priority
1	New or Excellent - None or minor defects.	Exceeds/Meets all performance targets.	It would be nice to have.
2	Good - Defects that have not begun to deteriorate.	Minor performance deficiencies.	Improved system operations & maintenance (O&M) efficiency.
3	Fair - Moderate defects that will continue to deteriorate.	Considerable performance deficiencies.	Internal safety concern or public nuisance.
4	Poor - Severe defects that will collapse/break in near future.	Major performance deficiencies.	Potential public health, safety, or environmental concern.
5	Inoperable - Defects need immediate attention.	Fails to meet performance targets.	Existing threat to public health, safety, or environment.

Water Line Assets

Size (inches)	Material	Decade Constructed	Length (feet)	Condition ID	Performance ID	Priority ID	WRIS PNum
Assessment Area: NORTH							
Up to 2	PVC	Unknown	542				
Up to 2	PVC	2000	12,411				
Up to 2	PVC	2010	37,480				
3	PVC	1990	42,391				
3	PVC	2000	149,415				
3	PVC	2010	52,132				
4	PVC	1990	152,859				
4	PVC	2000	91,975				
4	PVC	2010	2,681				
6	PVC	1990	84,527				
6	PVC	2000	20,964				
6	PVC	2010	12,178				
8	PVC	1990	39,869				
8	PVC	2000	51,159				
Assessment Area: SOUTH							
Up to 2	PVC	2000	12,359				
Up to 2	PVC	2010	9,829				
3	PVC	1990	37,423				
3	PVC	2000	46,649				
3	PVC	2010	78,986				
4	PVC	1990	289,435				
4	PVC	2000	93,120				
4	PVC	2010	39,090				
6	AC	2000	3,199				
6	PVC	1990	215,691				
6	PVC	2000	3,887				
8	PVC	2000	37,431				

WRIS Asset Inventory Report

KY0290271 - Cumberland County Water District

Rating Code	Condition Rating	Performance Rating	Priority Rating
0			Not a priority
1	New or Excellent - None or minor defects.	Exceeds/Meets all performance targets.	It would be nice to have.
2	Good - Defects that have not begun to deteriorate.	Minor performance deficiencies.	Improved system operations & maintenance (O&M) efficiency.
3	Fair - Moderate defects that will continue to deteriorate.	Considerable performance deficiencies.	Internal safety concern or public nuisance.
4	Poor - Severe defects that will collapse/break in near future.	Major performance deficiencies.	Potential public health, safety, or environmental concern.
5	Inoperable - Defects need immediate attention.	Fails to meet performance targets.	Existing threat to public health, safety, or environment.

Water Tank Assets							
Asset Name	Capacity (gallons)	Date Constructed	Date Inspected	Condition ID	Performance ID	Priority ID	WRIS PNum
Assessment Area: NORTH							
ALLEN CREEK	100,000	01/01/1986	09/01/2011				
MARROWBONE	300,000	06/30/2014	06/30/2014				
Assessment Area: SOUTH							
1880 TANK	50,000	01/01/1987	05/01/2011				
MT PISGAH--449	100,000	01/01/1970	09/01/2011				
SOUTH 61	100,000	01/01/1987	11/01/2016				

WRIS Asset Inventory Report

KY0290271 - Cumberland County Water District

Rating Code	Condition Rating	Performance Rating	Priority Rating
0			Not a priority
1	New or Excellent - None or minor defects.	Exceeds/Meets all performance targets.	It would be nice to have.
2	Good - Defects that have not begun to deteriorate.	Minor performance deficiencies.	Improved system operations & maintenance (O&M) efficiency.
3	Fair - Moderate defects that will continue to deteriorate.	Considerable performance deficiencies.	Internal safety concern or public nuisance.
4	Poor - Severe defects that will collapse/break in near future.	Major performance deficiencies.	Potential public health, safety, or environmental concern.
5	Inoperable - Defects need immediate attention.	Fails to meet performance targets.	Existing threat to public health, safety, or environment.

Pump Station Assets

Asset Name	Pump Count	Condition ID	Performance ID	Priority ID	WRIS PNum
Assessment Area: NORTH					
JONES RIDGE	2				
SOUTH 61					
Assessment Area: SOUTH					
ALBANY CONNECTION 1	2				
ALBANY CONNECTION 2 MYERS RIDGE	2				
CEDAR CREEK					
HWY 449	2				
JOE SCOTT RIDGE	2				

WRIS Asset Inventory Report

KY0290271 - Cumberland County Water District



Rating Code	Condition Rating	Performance Rating	Priority Rating
0			Not a priority
1	New or Excellent - None or minor defects.	Exceeds/Meets all performance targets.	It would be nice to have.
2	Good - Defects that have not begun to deteriorate.	Minor performance deficiencies.	Improved system operations & maintenance (O&M) efficiency.
3	Fair - Moderate defects that will continue to deteriorate.	Considerable performance deficiencies.	Internal safety concern or public nuisance.
4	Poor - Severe defects that will collapse/break in near future.	Major performance deficiencies.	Potential public health, safety, or environmental concern.
5	Inoperable - Defects need immediate attention.	Fails to meet performance targets.	Existing threat to public health, safety, or environment.

Water Treatment Plants

APPENDIX 2

WRIS System Data Report

KY0290271 - Cumberland County Water District

DOW Permit ID: **KY0290271**
 DOW Permit Type: **DRINKING WATER (PWSID)**
 DOW Permit Name: **Cumberland Co Water District**
 WRIS System Name: **Cumberland County Water District**

Link: [DOW SDWIS Report](#)

System Type: Community	Water Source Type: Surface Water Purchaser	ADD WMC Contact: Martina Hadley
ADD ID: LCADD	Primary County: Cumberland	Dow Field Office: Columbia
Permit Dates: Issued: 01.01.1973	Expired:	Inactivated:

OPERATIONS AND MANAGEMENT INFORMATION

Primary Facility Information:

This is a treatment facility.
 This is a maintenance facility.
 Facility Name: **Cumberland County Water District**
 Facility Contact: **Matthew Dyer**
 Facility Phone: **270-864-3133**
 Facility Addr 1: **133 Lower River St**
 Facility Addr 2:
 City, State Zip: **Burkesville, KY 42717**

System Management Entity Information:

Entity Name: **Cumberland County Water District**
 Office Phone: **270-864-3133** Fax: **270-864-3865**
 Office Address 1: **133 Lower River St**
 Office Address 2:
 City, State Zip: **Burkesville, KY 42717**

Date Last Modified: **05.22.2017**

System Management Contact Information:

Contact Type	Contact Name	Title	EEmail
1 Operations Contact:	Matthew Dyer	Manager	ccwateroffice@yahoo.com
2 Business Contact:	Julie Clemens	Business Contact	ccwateroffice@yahoo.com
Manager:	Matthew Dyer	Manager	ccwateroffice@yahoo.com

1 Person responsible for physical infrastructure operations.
 2 Person responsible for billing and financial operations.

Date Last Modified: **04.22.2022**

OWNER ENTITY INFORMATION

Entity Type: **Water District (KRS 74)** PSC Group ID: **20150**
 Entity Name: **Cumberland County Water District**
 Web URL:
 Office EMail: ccwateroffice@yahoo.com
 Office Phone: **270-864-3133** Toll Free: Fax:

Mail Address Line 1: 133 Lower River St	Phys Address Line 1:
Mail Address Line 2:	Phys Address Line 2:
Mail City, State Zip: Burkesville, KY 42717	Phys City, State Zip:

Contact: Matthew Dyer	Financial Contact:	Auth Official: Troy Norris
Contact Title: Manager	Financial Contact Title:	Auth Official Title: Chairman
Contact EMail: ccwateroffice@yahoo.com	Financial Contact EMail:	Auth Official EMail: ccwateroffice@yahoo.com
Contact Phone: 270-864-3133	Financial Contact Phone:	Auth Official Phone: 270-864-3133

Data Source: **Kentucky Infrastructure Authority**

Date Last Modified: **04.18.2019**

System Respondent

ADD WMP

Date

WRIS System Data Report

KY0290271 - Cumberland County Water District

DOW Permit ID: **KY0290271**
 DOW Permit Type: **DRINKING WATER (PWSID)**
 DOW Permit Name: **Cumberland Co Water District**
 WRIS System Name: **Cumberland County Water District**

Link: [DOW SDWIS Report](#)

System Type: Community	Water Source Type: Surface Water Purchaser	ADD WMC Contact: Martina Hadley
ADD ID: LCADD	Primary County: Cumberland	Dow Field Office: Columbia
Permit Dates: Issued: 01.01.1973	Expired:	Inactivated:

DEMOGRAPHIC INFORMATION

Counties Directly Served: 5 <table style="width: 100%; border-collapse: collapse;"> <tr> <td style="width: 50%;"></td> <td style="text-align: center;">Population</td> <td style="text-align: center;">Households</td> </tr> <tr> <td>Directly Serviceable:</td> <td style="text-align: center;">3,953</td> <td style="text-align: center;">2,306</td> </tr> <tr> <td>Indirectly Serviceable:</td> <td></td> <td></td> </tr> <tr> <td>Total Serviceable:</td> <td style="text-align: center;">3,953</td> <td style="text-align: center;">2,306</td> </tr> </table>		Population	Households	Directly Serviceable:	3,953	2,306	Indirectly Serviceable:			Total Serviceable:	3,953	2,306	<table style="width: 100%; border-collapse: collapse;"> <thead> <tr> <th style="text-align: center;">County Served</th> <th style="text-align: center;">Connection Count</th> <th style="text-align: center;">Serviceable Population</th> <th style="text-align: center;">Serviceable Households</th> <th style="text-align: center;">Med. HH Income</th> <th style="text-align: center;">MHI MOE</th> </tr> </thead> <tbody> <tr> <td>Clinton</td> <td style="text-align: center;">24</td> <td style="text-align: center;">98</td> <td style="text-align: center;">57</td> <td style="text-align: right;">\$44,040</td> <td style="text-align: right;">\$7,899</td> </tr> <tr> <td>Cumberland</td> <td style="text-align: center;">2,885</td> <td style="text-align: center;">3,772</td> <td style="text-align: center;">2,216</td> <td style="text-align: right;">\$39,454</td> <td style="text-align: right;">\$9,353</td> </tr> <tr> <td>Metcalfe</td> <td style="text-align: center;">32</td> <td style="text-align: center;">81</td> <td style="text-align: center;">32</td> <td style="text-align: right;">\$32,575</td> <td style="text-align: right;">\$6,182</td> </tr> <tr> <td>Monroe</td> <td style="text-align: center;">13</td> <td style="text-align: center;">2</td> <td style="text-align: center;">1</td> <td style="text-align: right;">\$44,826</td> <td style="text-align: right;">\$11,406</td> </tr> <tr> <td style="text-align: center;">Totals:</td> <td style="text-align: center;">2,954</td> <td style="text-align: center;">3,953</td> <td style="text-align: center;">2,306</td> <td style="text-align: right;">\$39,474</td> <td style="text-align: right;">\$9,274</td> </tr> </tbody> </table>	County Served	Connection Count	Serviceable Population	Serviceable Households	Med. HH Income	MHI MOE	Clinton	24	98	57	\$44,040	\$7,899	Cumberland	2,885	3,772	2,216	\$39,454	\$9,353	Metcalfe	32	81	32	\$32,575	\$6,182	Monroe	13	2	1	\$44,826	\$11,406	Totals:	2,954	3,953	2,306	\$39,474	\$9,274
	Population	Households																																															
Directly Serviceable:	3,953	2,306																																															
Indirectly Serviceable:																																																	
Total Serviceable:	3,953	2,306																																															
County Served	Connection Count	Serviceable Population	Serviceable Households	Med. HH Income	MHI MOE																																												
Clinton	24	98	57	\$44,040	\$7,899																																												
Cumberland	2,885	3,772	2,216	\$39,454	\$9,353																																												
Metcalfe	32	81	32	\$32,575	\$6,182																																												
Monroe	13	2	1	\$44,826	\$11,406																																												
Totals:	2,954	3,953	2,306	\$39,474	\$9,274																																												

Note: Population counts are based on KIA census block overlay with WRIS mapped features.

MHI Source: American Community Survey 2018-2022 5 Yr Estimates (Table B19013). MHI MOE = Med HH Income Margin of Error.

FISCAL ATTRIBUTES

Date Established: **01.01.1973** Employees: **8**

Does this system: If this is a municipal system, what is the cost per 4,000 gallons of finished water for customers:

(a) Produce Water? No	(a) inside your municipality:
(b) Have wholesale customers? No	(b) outside your municipality:
(c) Purchase water? Yes	

If this is a non-municipal system, what is the customer cost per 4,000 gallons of finished water? **\$50.07**

Date of Last Rate Adjustment: **12-01-2023**

Comments:

Date Last Modified: **05.09.2024**

Providers that sell water to this system:

Seller DOW Permit ID	Seller Name	Water Type	Ann. Vol. (MG)	Cost		Interconnects		
				Raw	Fin	Perm	Seas	Emer
KY0270003	Albany Municipal Water & Sewer	F	36.609		\$2.10	1	0	0
KY0290049	Burkesville Municipal Water Works	F	166.475		\$2.15	2	0	0
Totals and Averages					\$2.13	3	0	0

- MG = Million Gallons
- Water Types: R = Raw Water, F = Finished Water, B = Both Raw and Finished Water
- Cost Categories: Raw = Raw Untreated Water, Fin = Finished Treated Water
- Raw and Finished costs are per 1,000 gallons.
- Interconnect Types: Perm = Permanent, Seas = Seasonal, Emer = Emergency

WRIS System Data Report

KY0290271 - Cumberland County Water District

DOW Permit ID: **KY0290271**
 DOW Permit Type: **DRINKING WATER (PWSID)**
 DOW Permit Name: **Cumberland Co Water District**
 WRIS System Name: **Cumberland County Water District**

[Link: DOW SDWIS Report](#)

System Type: Community	Water Source Type: Surface Water Purchaser	ADD WMC Contact: Martina Hadley
ADD ID: LCADD	Primary County: Cumberland	Dow Field Office: Columbia
Permit Dates: Issued: 01.01.1973	Expired:	Inactivated:

SYSTEM PLANNING

Water Treatment Plants:

Facility Name	Design Capacity (MGD)	Ave. Daily Prod. (MGD)	High. Daily Prod. (MGD)
Totals			

Operational Statistics:

	WRIS	SDWIS MOR
Total Annual Vol. Produced (MG):		
Total Annual Vol. Purchased (MG):	203.084	240.459
Total Annual Vol. Provided (MG):	203.084	240.459
Estimated Annual Water Loss:	41%	50%

	WRIS	SDWIS MOR
Wholesale Customers: Wholesale Usage (MG):		
Residential Customers: 2,853 Residential Usage (MG):	93.026	
Commercial Customers: 94 Commercial Usage (MG):	15.339	
Institutional Customers: Institutional Usage (MG):		
Industrial Customers: 6 Industrial Usage (MG):	0.230	
Other Customers: 1 Other Cust. Usage (MG):	7.810	
Total Customers: 2,954		
Flushing, Maintenance and Fire Protection Usage (MG):	3.386	
Total Annual Water Usage (MG):	119.791	119.791

Water supply inadequacies during normal operating conditions:

None

Water supply inadequacies during drought operating conditions:

None

Comments: **None.**

Date Last Modified: **05.09.2024**

WMP Site Visit - Survey Information:

Site Visit / Survey Date: **04.22.2024**
 Survey Administrator: **Martina Hadley**
 Principal Respondent: **Matthew Dyer, Manager**
 Other Respondent(s):
 Comments: **None.**

Date Last Modified: **06.05.2024**

SYSTEM MAINTENANCE

- The management of this system participates in an Area Water Management Planning Council (AWMPC).
- The management of this system participates in regular training activities.
- System operator(s) participate in regular training activities.
- This system has an asset management plan.
Date asset management plan last updated:
- This system as a capital improvement plan.
Date capital improvement plan last updated:
- This system has GIS capabilities.
Date GIS data last submitted to the WRIS: **01/01/2020**

This system has a policy manual in place containing the following items:

- Personnel Policies
- Standard Operating Procedures
- Line Maintenance Program
- Meter Testing Program
- Routine Pressure Checks
- Pump Station Maintenance Schedule
- Emergency Operation Procedures
- Backup Sources
- A Water Shortage Plan
- A Water Conservation Plan

Date of last DOW Sanitary Survey: Month: **2**, Year: **2023**

- This system has periodic service outages.
Cause(s): **Line breaks**
- This system has periodic pump failures.
Cause(s):
- This system has periodic line breaks.
The following components are associated with periodic line breaks:
Typical line size: **6.00, 3.00, & 4.00**
Typical line location(s): **Private easement**
Typical cause(s): **Natural breaks, cable and road contractors**
Other cause(s):
Est. Water Loss Percentage: **34.0 %**
- This system has localized problems.
The following components are associated with localized problems:
Problem location(s):
Problem diameter(s):
Problem pressure(s):
Problem cause(s):
Other problem characteristics:
- This system has as-built plans (record drawings).
Est. degree of accuracy for as-built plans (%): **31%**
- This system uses an on-staff inspector(s) for construction projects.

Maintenance notes for this system:

Date Last Modified: **05.10.2023**

WRIS System Data Report

KY0290271 - Cumberland County Water District

The following projects are associated with this system (included constructed projects):

PNUM	Applicant	Project Status	Funding Status	Schedule	Project Title	Agreed Order	Profile Modified	GIS Modified
WX21053028	City of Albany	Approved	Not Funded	0-2 Years	Albany - Water Treatment Plant (A & B) Raw Water Pumps	Y	03.08.2024	
WX21053029	City of Albany	Approved	Not Funded	0-2 Years	Albany Water Treatment Plant (A & B) Expansion	Y	03.08.2024	
WX21053031	City of Albany	Approved	Not Funded	0-2 Years	Albany - Water Treatment Plant B Filter Rehabilitation	Y	07.30.2024	
WX21053032	City of Albany	Approved	Partially Funded	0-2 Years	Albany - Water Treatment Plant A and B Backup Generators	Y	09.03.2024	
WX21053036	City of Albany	Approved	Not Funded	0-2 Years	Albany WTP A & B Repairs and Rehab	Y	08.22.2024	
WX21057004	Cumberland County Water District	Approved	Not Funded	6-10 Years	Zeketown Road Water Line Extension	N	04.06.2012	01.26.2012
WX21057010	Cumberland County Water District	Constructed	Partially Funded	0-2 Years	CUMBERLAND CO WATER DISTRICT IMPROVEMENTS	N	03.01.2011	09.02.2010
WX21057012	Cumberland County Water District	Constructed	Fully Funded	3-5 Years	CCWD – Burkesville Interconnection and Water Storage Tank Replac	N	01.08.2018	11.26.2012
WX21057013	Cumberland County Water District	Constructed	Partially Funded	3-5 Years	2014 Water System Improvements	N	10.02.2019	01.06.2017
WX21057015	Cumberland County Water District	Constructed	Fully Funded	0-2 Years	Cumberland Co Water District Potters Creek Waterline Extension	N	04.06.2012	09.02.2010
WX21057016	Cumberland County Water District	Constructed	Fully Funded	3-5 Years	CCWD - Improvements and Extensions	N	01.08.2018	09.02.2010
WX21057018	Cumberland County Water District	Approved	Not Funded	3-5 Years	Burkesville Interconnection (North Highway 61)	N	12.17.2018	02.12.2014
WX21057020	Cumberland County Water District	Constructed	Fully Funded	3-5 Years	Sulphur Creek Road Water System Improvements	N	10.02.2019	02.11.2016
WX21057021	Cumberland County Water District	Approved	Not Funded	3-5 Years	Kentucky Highway 704 Water System Improvements	N	12.11.2017	02.14.2017
WX21057022	Cumberland County Water District	Approved	Partially Funded	0-2 Years	Marrowbone Area Water System Replacement	N	07.30.2024	04.28.2020
WX21057023	Cumberland County Water District	Approved	Not Funded	0-2 Years	Bull Ridge Road Water Line Extension	N	07.29.2021	07.19.2021
WX21057024	Cumberland County Water District	Approved	Fully Funded	0-2 Years	Butler Hollow Road Water Line Extension	N	09.27.2022	07.19.2021
WX21057025	Cumberland County Water District	Approved	Fully Funded	0-2 Years	Charles Norris Road Water Line Extension	N	11.22.2023	07.19.2021
WX21057026	Cumberland County Water District	Approved	Fully Funded	0-2 Years	Crawley Road Water Line Extension	N	09.27.2022	07.19.2021
WX21057027	Cumberland County Water District	Approved	Not Funded	0-2 Years	Donnie Smith Road Water Line Extension	N	07.29.2021	07.19.2021
WX21057028	Cumberland County Water District	Approved	Not Funded	0-2 Years	Warsaw Branch Road Water Line Extensions	N	07.29.2021	07.19.2021
WX21057029	Cumberland County Water District	Approved	Not Funded	0-2 Years	CUMBERLAND / ADAIR CONNECTOR - KENTUCKY HIGHWAY 61	N	08.22.2024	08.02.2024
WX21133064	Cumberland River Water Commission	Approved	Not Funded	3-5 Years	Regional Decentralized WTP Project	N	08.06.2021	
WX21235007	Corbin City Utilities Commission	Approved	Not Funded	0-2 Years	Corbin Water Treatment Plant Sodium Hypochlorite Disinfection Fa	N	03.11.2024	

APPENDIX 3

Cumberland Co Water District Meter Quarterly Test Report

Meter Category *All*
 Selected Year *2024*
 Selected Quarter *Quarter 1 (01/01-3/31)*
 Service Status *Begin* *New* *Active* *Pending*
 Final *Bad Debt* *Inactive*

	Less Than 2 Years	2 to 4 Years	4 to 6 Years	6 to 8 Years	8 to 10 Years	Over 10 Years	Time Unknown	Total
< -10.1	0	0	0	0	0	0	0	0
-5.1 to -10.0	0	0	0	0	0	0	0	0
-4.1 To -5.0	0	0	0	0	0	0	0	0
-3.1 To -4.0	0	0	0	0	0	0	0	0
-2.1 To -3.0	0	0	0	0	0	0	0	0
-1.1 To -2.0	0	0	0	0	0	0	0	0
-0.1 To -1.0	143	0	0	0	0	0	0	143
0	5	0	0	0	0	0	0	5
0.1 To 1.0	23	6	10	1	0	0	0	40
1.1 To 2.0	0	0	0	0	0	0	0	0
2.1 To 3.0	0	0	0	0	0	0	0	0
3.1 To 4.0	0	0	0	0	0	0	0	0
4.1 To 5.0	0	0	0	0	0	0	0	0
5.1 To 10.0	0	0	0	0	0	0	0	0
> 10.1	0	0	0	0	0	0	0	0
Total	171	6	10	1	0	0	0	188

Customer Type	Customer Type		
	Metered	UnMetered	Total
Church	40	0	40
Commercial	81	0	81
Farm	44	0	44
Flush	14	0	14
Industrial	5	0	5
Master Meter	33	0	33
Non-profit	11	0	11
Park	1	0	1
Residential	1,737	0	1,737
Residential Non-Domicile	888	0	888
Seasonal Residential	18	0	18

Meters removed from service or tested this period: 27
 New meters tested by utility or approved agency: 161
Total Meters Tested In This Period 188

Reason For	
Billing Issue	1
New Testing	169
Periodic Testing	18
Total	188

	Less Than 2 Years	2 to 4 Years	4 to 6 Years	6 to 8 Years	8 to 10 Years	Over 10 Years	Time Unknown	Total
Total	2872	0	2872					

APPENDIX 4

HYDRUS

ULTRASONIC METER

DIEHL
Metering



APPLICATION

Highly accurate, lead-free brass ultrasonic smart water meter for residential, commercial and industrial installations.

FEATURES

- ▶ Extreme low-flow accuracy and long term measurement stability
- ▶ Integrated leak detection
- ▶ Mountable in any installation position
- ▶ Lead-free copper alloy body
- ▶ IP68 rated
- ▶ 42 days of hourly data storage
- ▶ Diehl Extended Encoder protocol that includes temperature, alarms and error messages, etc.
- ▶ Meets or exceeds C715 AWWA/ANSI Standards
- ▶ Complies with NSF/ANSI Standards 61, Annex F/G as well as FCC part 15 B

HYDRUS

ULTRASONIC METER

GENERAL TECHNICAL DATA

HYDRUS	
Potable water temperature	°F 33 ... 122
Ambient operating temperature	°F -13 ... 131
Ambient storage temperature	°F -13 ... 158 (90° F max. for one hour)
Maximum operating pressure	psi 300
Power supply	Two 3.6 VDC lithium batteries
Battery lifetime	Up to 20 years
Encoder interface	9 digit programmable resolution industry standard encoder protocol, ASCII output for compatibility with most AMR/AMI systems, Diehl extended protocol is available
Data storage	Alarms and consumption values (42 days of hourly data storage)
Protection class	IP68

TECHNICAL DATA DISPLAY

HYDRUS	
Display indication	LCD, 9-digit, additional symbols/display counter/unit
Units	Flow and volume (gpm, gal, ft ³ , m ³)
Values displayed	Display test - total volume - firmware version / checksum - current flow - errors / alarms (Additional values based on configuration)
Alarms	Hardware flow - leak detection - backflow - air in pipe - low battery - undersized meter - no consumption - high temperature - freezing risk

APPROVAL

HYDRUS	
NSF	Complies with NSF/ANSI Standard 61, Annex F/G
AWWA	Meets or exceeds applicable sections of the AWWA/ANSI C715 Standards
FCC	Complies with FCC part 15 B

MATERIAL

HYDRUS	
Measuring pipe	Lead-free copper alloy (stainless steel 1½" & 2")
Register housing	Engineered polymer
Transducers	Composite
Reflectors	Stainless steel

HYDRUS

ULTRASONIC METER

TECHNICAL DATA

Size		5/8" x 1/2"	5/8" x 3/4"	3/4"S	3/4"
Lay length	inch	7 1/2	7 1/2	7 1/2	9
Operating flow range	gpm	0.08 - 22	0.08 - 22	0.1 - 32	0.1 - 32
Low flow range	gpm	0.025 - 0.08	0.025 - 0.08	0.04 - 0.1	0.04 - 0.1
Starting flow	gpm	0.011	0.011	0.017	0.017
Operating range accuracy	%	±1.5	±1.5	±1.5	±1.5
Low flow range accuracy	%	±5	±5	±5	±5
Pressure loss	psi	4.3@15 gpm	4.3@15 gpm	2.0@15 gpm	2.0@15 gpm

Size		1"	1 1/2"	2"
Lay length	inch	10 3/4	13	17
Operating flow range	gpm	0.1 - 55	0.16 - 100	0.8 - 170
Low flow range	gpm	0.055 - 0.1	0.1 - 0.16	0.55 - 0.8
Starting flow	gpm	0.025	0.038	0.11
Operating range accuracy	%	±1.5	±1.5	±1.5
Low flow range accuracy	%	±5	±5	±5
Pressure loss	psi	1.5@25 gpm	3.5@70 gpm	3.6@110 gpm

DIMENSIONS

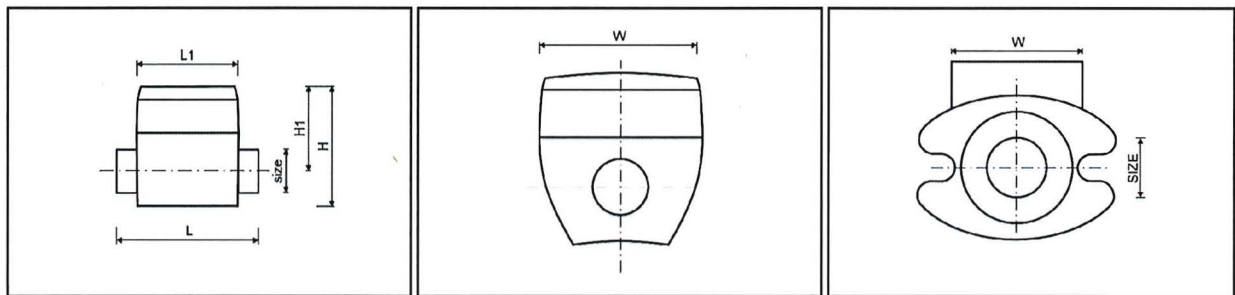

Size		5/8" x 1/2"	5/8" x 3/4"	3/4"S	3/4"
Lay length	inch	7 1/2	7 1/2	7 1/2	9
Register length	L1	inch	3.5	3.5	3.5
Register width	W	inch	3.7	3.7	3.7
Overall height	H	inch	4.0	4.0	4.0
Height from center of pipe to top	H1	inch	2.7	2.7	2.7
Nominal thread size		3/4" - 14 NPSM	1" - 11 1/2 NPSM	1" - 11 1/2 NPSM	1" - 11 1/2 NPSM
Net weight	lbs.	2.8	2.8	2.8	3.1

Size		1"	1 1/2"	2"
Lay length	inch	10 3/4	13	17
Register length	L1	inch	3.5	3.5
Register width	W	inch	3.7	3.7
Overall height	H	inch	4.2	5.3
Height from center of pipe to top	H1	inch	2.8	3.3
Nominal thread size		1/4" - 11 1/2 NPSM	oval flanges	oval flanges
Net weight	lbs.	3.5	14.1	19.2

Superior Accuracy. Zero Maintenance.

Neptune® MACH 10® Ultrasonic Meter



The MACH 10® ultrasonic water meter features solid state ultrasonic technology including a factory-calibrated, replaceable unitized measuring element (UME) with no degradation of accuracy over time. Combined with a corrosion-resistant, lead free, high-copper alloy maincase, the MACH 10 is built to withstand demanding service conditions and deliver sustained accuracy over the life of the meter.

- Sizes 3" through 12"
- Extended low-flow range for superior leak detection
- Accuracy sustained over meter life
- Can be installed in both horizontal and vertical applications
- Open flow path design with low pressure loss
- Advanced ultrasonic technology with easily replaceable UME design
- Lead free, high-copper alloy maincase
- UL Listed and FM Approved (standard)
- Available in standard turbine and compound lay lengths
- No maintenance



NEPTUNE
TECHNOLOGY GROUP
#winyourday

Specifications

AWWA C715 Compliant

NSF/ANSI 61 Certified

UL Listed/FM Approved
(Standard)

Maximum Operating Water Pressure

- 175 psi

Operating Water Temperature Range

- +33°F to +122°F (+0.5°C to +50°C)

Environmental Conditions

- Operating temperature:
+14°F to +149°F (-10°C to +65°C)
- Storage temperature:
-40°F to +158°F (-40°C to +70°C)

Expected Battery Life

- 10 years

Applications

- Potable water
- Fire service
- Reclaim water

Warranty

- Neptune provides a limited warranty for performance, materials, and workmanship. See warranty statement for details.

System Compatibility

- Compatible with Neptune R900® System. Also available as MACH 10®)R900i™ for an integrated radio solution and MACH 10®)TC for Sensus Touch Coupler compatibility.

Pressure Loss

This chart shows typical meter performance. Individual results may vary.

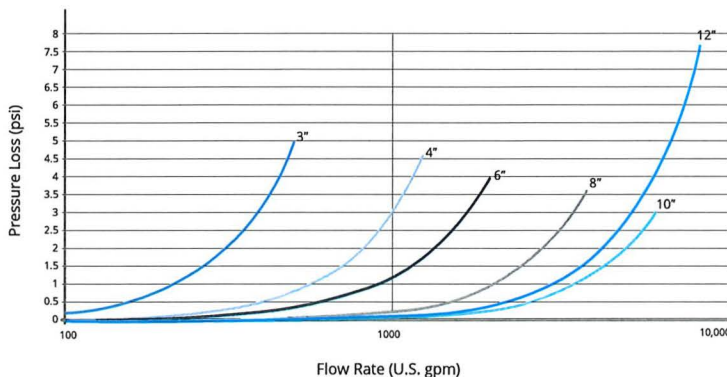

Operating Characteristics

Meter Size	Extended Low Flow @ 100% Accuracy (+/- 3.0%)	Normal Operating Range @ 100% Accuracy (+/- 1.5%)	Safe Maximum Operating Capacity	
			Normal Operation (Non Fire Service)	Fire Service
3"	0.50 U.S. gpm	0.75 to 500 U.S. gpm	500 U.S. gpm	420 U.S. gpm
4"	0.75 U.S. gpm	1.5 to 1250 U.S. gpm	1250 U.S. gpm	1100 U.S. gpm
6"	1.0 U.S. gpm	2.0 to 2000 U.S. gpm	2000 U.S. gpm	1800 U.S. gpm
8"	4.0 U.S. gpm	6.0 to 4000 U.S. gpm	4000 U.S. gpm	4000 U.S. gpm
10"	6.0 U.S. gpm	10.0 to 6500 U.S. gpm	6500 U.S. gpm	6500 U.S. gpm
12"	8.0 U.S. gpm	12.0 to 8000 U.S. gpm	8000 U.S. gpm	8000 U.S. gpm

Registration

High Resolution (8-digit reading)		3"	4"	6" - 12"
1	U.S. Gallons	✓	✓	
10	U.S. Gallons			✓
0.1	Cubic Feet	✓	✓	
1	Cubic Feet			✓
0.01	Cubic Metres	✓	✓	
0.1	Cubic Metres			✓

LCD Display

9-digit display for extra resolution on manual reads.

Forward Flow + Warning for Excessive Flow

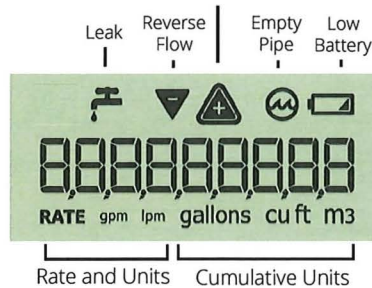

Dimensions

Meter Size	Length	Height	Weight
3"	12"	9½"	39 lbs
	17"	9½"	42 lbs
4"	14"	11"	51 lbs
	20"	11"	57 lbs
6"	18"	12¾"	79 lbs
	24"	12¾"	91 lbs
8"	20"	15 ⅝"	160 lbs
10"	26"	17 ⅞"	264 lbs
12"	19 ⅞"	20"	292 lbs

Available Units of Measure

Consumption	Rate
Gallons	GPM
Cubic Feet	GPM
Cubic Metres	LPM



Unitized Measuring Element (UME)



Neptune Technology Group
1600 Alabama Highway 229
Tallahassee, AL 36078
800-633-8754 f 334-283-7293

AMI Your Way

Neptune® R900® System: Cellular Endpoint



Neptune's cellular endpoint allows you to progress at your own pace to AMI when integrated into your Neptune® R900® System. Neptune's cellular endpoint provides all of the benefits of an advanced meter reading solution without the operational burden of network infrastructure while allowing you to protect existing asset investments. An easily deployable AMI solution, the cellular endpoint allows you to start collecting actionable meter data immediately. Powered by the FirstNet® cellular network, you are assured a reliable, highly secure, and easy-to-deploy AMI data solution for both current and future needs.

- No AMI fixed network infrastructure installation, maintenance, operations, or upgrade costs for the life of the deployment.
- Seamless integrations with existing R900 technology for a flexible AMI solution.
- Access all of your meter data from anywhere at any time with Neptune® 360™.
- Improve operations and customer service with real-time, high-resolution AMI data and advanced analytics.
- Automatically recover from network outages with 96 days of stored data.

FirstNet®, Built with AT&T

- Two-way solution using the FirstNet® LTE-M cellular technology helps ensure robust coverage.
- Prioritized connectivity, even during natural disasters, protects against commercial traffic congestion.
- Network resources and mobile cell sites can be dispatched during disaster recovery to support network connectivity.
- Sensitive information is highly secure on the FirstNet® network.

Specifications

Environmental Conditions

- Operating temperature:
-22°F to +149°F (-30°C to +65°C)
- Storage temperature:
-40°F to +158°F (-40°C to +70°C)
- Operating humidity:
100% condensing

Antennas

- Wall: standard internal antenna
- Pit: internal or external antenna

Encoded Register Compatibility

- Neptune® MACH 10®, ARB®V, ProRead™, E-CODER®, and ProCoder™
- Sensus ECR II, ICE, iPerl, Electronic Register and OMNI
- Hersey/Mueller Translator
- Badger ADE, HR E|LCD, E-Series
- Elster/AMCO InVision (Sensus protocol version)

Operation

- Regular cellular LTE-M transmissions with configurable transmission windows
- Mobile 900 MHz backup transmissions
- Verify installation via the cellular endpoint manager tool
- 15-minute interval data with automatic back-fill
- Priority alerts

Warranty

- Neptune provides a limited warranty for performance, materials, and workmanship. See warranty statement for details.

Dimensions

Wall Endpoint

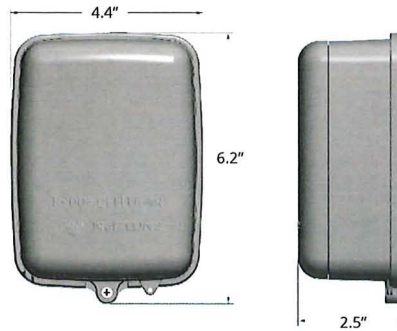

Pit Endpoint (Internal Antenna)

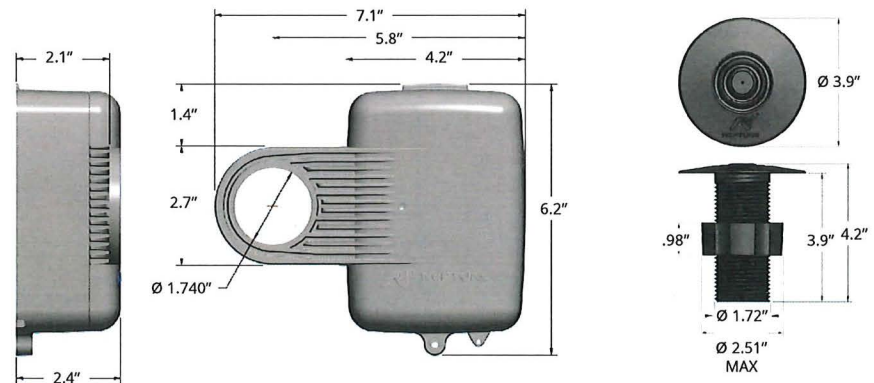

Pit Endpoint with External Through-the-Lid Antenna

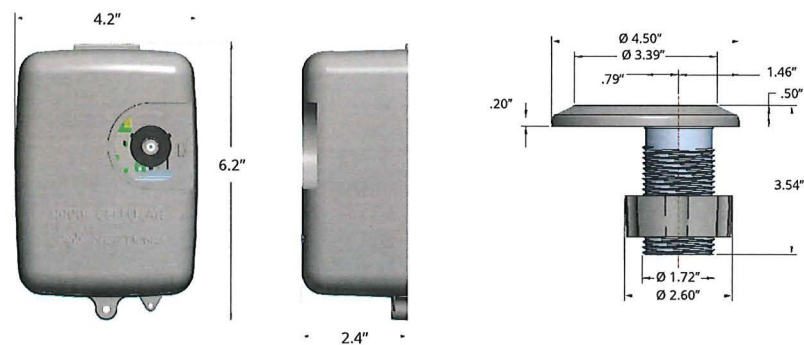

©2023 AT&T Intellectual Property. FirstNet, First Responder Network Authority, and FirstNet logo are registered trademarks and service marks of FirstNet, an independent authority within the U.S. Department of Commerce. All other marks are the property of their respective owners.

©2023 Neptune Technology Group Inc. All Rights Reserved. The trademarks, logos and service marks displayed in this document herein are the property of Neptune Technology Group Inc., its affiliates or other third parties. Availability and technical specifications are subject to change without notice. 23-009650 PS R900 CELLULAR ENDPOINT-US 03.23



Neptune Technology Group
1600 Alabama Highway 229
Tallahassee, AL 36078
800-633-8754 f 334-283-7293



Commercial & Industrial (C&I) MACH 10[®] Ultrasonic Meters

Maincase

[Why did Neptune design the C&I MACH 10[®] ultrasonic meter with a bronze maincase?](#)

The corrosion-resistant lead free high copper alloy maincase is built to withstand demanding service conditions, internal water pressure, rough handling, and in-line piping stress. With the C&I MACH 10 meter, there is no concern of corrosion due to the casing material. Neptune believes that if a meter is capable of providing sustained accuracy over its life, the maincase must be designed to last the meter's life as well.

[Is the C&I MACH 10 meter bronze maincase lead free?](#)

Yes. Like all Neptune MACH 10 meters, the C&I MACH 10 meter is lead free and ANSI/NSF 61 approved.

Battery

[Does the MACH 10 utilize a battery?](#)

Yes. All solid state meter technologies require a battery to operate. The battery powers the metrology and the LCD.

[What is the battery life of the C&I MACH 10?](#)

The battery inside the UME has a life of 10 years.

[Can the C&I MACH 10 meter's battery be replaced?](#)

No. The battery in the C&I MACH 10 meter is permanently potted and sealed as part of the meter assembly for protection against moisture intrusion.

[How will I know if a C&I MACH 10 meter's battery is low on power?](#)

The C&I MACH 10 meter features low battery detection and notification. A low battery icon will appear on the LCD panel. With an enhanced R900[®], the low battery condition will also be reported to the host software.

Unitized Measuring Element (UME)

[Does the C&I MACH 10 meter have a replaceable UME?](#)

Yes, if required, the meter's UME can be replaced easily, eliminating the need to replace the entire meter.

[Can the battery in the UME be replaced?](#)

No. Because the electronics are fully potted for waterproofing, the UME must be replaced when the battery dies.

[Can the C&I MACH 10 UME be used with a mechanical meter's maincase?](#)

The unique shape of the C&I MACH 10 flow tube and internal sealing requirements make the UME incompatible with existing turbine and compound maincases.

[Can I order replacement parts?](#)

If the plastic meter lid becomes damaged or broken, it can be replaced. The UME assembly for sizes 3"-6" may also be replaced, but there are no other replacement parts for the MACH 10 ultrasonic meter.



Warranty

What is the C&I MACH 10 warranty?

The C&I MACH 10 meters have a 10-year accuracy and electronics warranty. Coverage for the electronics, which includes the battery, is five years full and five years prorated. The maincase is covered for the life of the meter and can remain in service during a UME changeout. Please contact your TM for a copy of the full warranty.

Liquid Crystal Display (LCD)

Does the MACH 10 meter's LCD remain on when the lid is closed?

No. A photo cell senses when the lid is closed and turns off the LCD for battery conservation.

Will the LCD remain on if the lid is broken off of the C&I MACH 10 meter?

No. After ten minutes the LCD will power down for battery conservation. The LCD can be reactivated by temporarily covering the photo cell sensor.

Applications

Can the C&I MACH 10 meter be installed in flooded meter pit applications?

Yes. The C&I MACH 10 meter's electronics and battery are fully potted, suitable for submersion in a pit environment.

What happens if an empty pipe condition occurs?

The C&I MACH 10 meter will not be able to register consumption and will display an empty pipe icon on the LCD.

Can the MACH 10 register reverse flow?

Yes. The C&I MACH 10 meter is capable of measuring reverse flow. The LCD odometer will run in reverse when reverse flow occurs. A flag is set in the meter firmware to communicate this occurrence to the host software for notification when the meter is read. The C&I MACH 10 meter communicates reverse flow exactly like the E-CODER®.

Does the C&I MACH 10 meter measure the speed of particles moving with the flow of water?

No. The C&I MACH 10 meter measures fluid velocity by measuring transit times of upstream and downstream ultrasonic waves; the difference in these times is proportional to flow rate. Volume is determined by the multiplication of the velocity of water, area of the pipe, and elapsed time.

Is a ground strap required for the C&I MACH 10 meter?

Neptune does not specifically require a ground strap for correct meter operation. Check your local codes to ensure ground straps are not required for your particular installation.

Does air in the meter chamber affect its accuracy?

Yes. If air remains in the meter chamber, accuracy can be affected. The C&I MACH 10 meter provides an air bleed screw to facilitate purging air at the time of installation.

Are there any upstream or downstream straight pipe length requirements when installing a MACH 10 meter?

The C&I MACH 10 does not require any straight pipe upstream or downstream the meter to meet AWWA C715 standards. Neptune's flow ranges and accuracy standards exceed those of AWWA, so in order to meet our more stringent standards some configurations may require minimum amounts of straight pipe. Any configuration with five (5) diameters of straight pipe upstream the meter will meet Neptune accuracy standards.



What length of straight pipe is required upstream and downstream the meter in order to maximize accuracy?

While no straight pipe is required to meet AWWA C715 accuracy standards, in order to meet Neptune's standards and maximize the accuracy of your measurements, consider following recommendations below:

Strainer: The meter does not require the use of a strainer. If a strainer is desired, it may be installed immediately downstream the meter or five (5) diameters upstream the meter. During meter replacement, if a strainer is already installed upstream, the C&I MACH 10 will meet all AWWA C715 accuracy standards for static meters. To attain the meter's highest accuracy capabilities, consider moving the strainer downstream the meter.

Elbows: Elbows (90°) may be installed five (5) pipe diameters upstream the meter and/or directly downstream the meter.

Valves: Fully open gate valves or ball valves may be installed immediately upstream or downstream the meter. Fully open isolation valves or butterfly valves may be installed at least five (5) pipe diameters upstream the meter or immediately downstream the meter. If control valves, check valves, or backflow preventers are needed, install them downstream of the meter to avoid cavitation. Do not install the meter on a pump suction side.

Test Tee: If a test tee is desired, install it so that the test port is facing straight up, aligned with the meter's register. The center of the test port must be a minimum of one (1) pipe diameter from the outlet flange of the meter. 2" test ports are recommended.

Can the C&I MACH 10 meter be installed vertically?

Yes, the MACH 10 can be mounted horizontally, vertically, or in a slanted orientation.

Will the C&I MACH 10 meter be UL Listed and FM approved?

Yes, all C&I MACH 10 meters come standard with both UL Listing and FM Approval. They can be used as a replacement for both Fire Service HP Turbine and PROTECTUS® meters. Refer to the product sheet for the meter flow rate specifications.

Is the C&I MACH 10 susceptible to build-up on the mirrors?

Our tests show that the material we selected for transducers and mirrors/reflectors resists build-up and the MACH 10 generates a robust signal. However, no metering technology is completely immune to build-up.

Can I use the C&I MACH 10 in an application where water is known to freeze in-line?

Unlike traditional positive displacement meters, MACH 10 meters do not offer traditional frost protection bottom caps, since they are not repairable. MACH 10 meters should not be placed in settings where freezing is possible.

Can I use a TRICON/E/S with my C&I MACH 10?

The TRICON/E® and TRICON/S® cannot be used with a MACH 10. Neptune has evaluated third-party output module products from Scadmetrics® and F.S. Brainard & Co., and confirmed their compatibility with the C&I MACH 10. Compatible interfaces include: 1) 4-20mA current loop 2) scaled switch closure 3) digital pulse output. These modules allow for simultaneous ARB and industrial output and are available through the manufacturer.

Communication

What meter protocol does the MACH 10 output?

The C&I MACH 10 meter outputs standard E-CoderPLUS protocol and is compatible with Neptune R900, Pocket ProReader, and Advantage Reading Systems. In addition, the C&I MACH 10 meter is compatible with other suppliers' endpoints, such as the Itron 100W, Sensus RadioRead and FlexNet, Aclara MTUs, and Badger Orion LTE-M (so long as these companies continue to follow the published E-CODER 8-digit mode specifications).



Does the MACH 10 transmit alarms/flags to competitive radios?

Neptune shares the details of our E-CODER 8-digit protocol with Badger, Sensus, Aclara, and Itron so that they can interface their reading devices to the MACH 10. Meter generated alarm flags are only available with Neptune endpoints. Most competitive radios/HES generate alarms independently using volume data from the meter, please consult with these suppliers for details on which alarms they generate.

Is the C&I MACH 10 meter AMR/AMI capable?

Yes. The C&I MACH 10 supports operation with Neptune's full range of endpoints, which provide Smart Water AMI Network Connectivity via LoRaWAN, cellular/LTE, Neptune's proprietary AMI protocols, and select third-party AMR/AMI meter reading systems.

Does the C&I MACH 10 meter provide data logging?

Yes, data logging is provided when connected to, or integrated with, an R900 v4 or newer endpoint.

How many digits of volume does the C&I MACH 10 provide?

LCD resolution for visual reading and test purposes is nine digits. E-CoderPLUS protocol output provides 8-digit resolution to all Neptune endpoints, and many competitive endpoints (Aclara, Sensus, Itron, Badger) when these are configured appropriately.

Specifications & Performance

Does the C&I MACH 10 meter have any internal moving parts?

No. The C&I MACH 10 meter utilizes "transit time" ultrasonic technology featuring no moving parts.

What is the pressure rating of the C&I MACH 10 meter?

Maximum operational pressure is 175PSI.

Does the C&I MACH 10 meter have excessive pressure loss due to the flow conditioner and mirrors inside the maincase?

No. The pressure loss exceeds all requirements of AWWA C715. Additionally, the C&I MACH 10 meters utilize a mirror position that does not impede flow and also does not use an adjunct flow conditioner.

What sizes are offered in the C&I MACH 10 meter?

The C&I MACH 10 meter is offered in 3", 4", 6", 8", 10", and 12" sizes.

Can the C&I MACH 10 meter easily retrofit existing turbine and compound meter installations?

Yes. The C&I MACH 10 meter's lay lengths are the same as common turbine and compound meter lay lengths for drop in replacements.

Does accuracy diminish over time with the C&I MACH 10 meter?

No. A benefit of solid state meter technologies is no moving parts, meaning no wear over time to diminish meter accuracy.

Does the MACH 10 need to be calibrated?

All MACH 10 meters are individually calibrated in our factory. The calibration lasts for the life of the meter. No field calibration is necessary or possible.

How does the C&I MACH 10 low flow compare to a TRU/FLO® compound meter?

Overall, the C&I MACH 10 accuracy is comparable to the TRU/FLO. While extended low flow rates are not the same, the MACH 10 benefits from not having a crossover range which negatively impacts the compound meter's accuracy. Because a significant portion of metered consumption happens in the crossover range, the MACH 10 has a significant advantage in measurement accuracy over compound meters.



A tool for comparing the details of the C&I MACH 10 to Neptune's mechanical meters can be found at neptunetg.com/mach10.

Does stray noise affect the ultrasonic measurement?

There are several ways that we manage the effect of stray signals. The transducers themselves have a specific resonance frequency so any other noise does not excite the receiving transducer. There is a time window based on pipe size and time of flight in which the transducers are looking for the signal and everything outside of that window is ignored. This window takes into account the minimum and maximum time of flight based on flow rate and water temperature. Additionally, there are checks in place to correct for stray signals based on the history of the time of flight.

Do particulates in the water affect the meter's accuracy?

Small particles and small bubbles suspended in solution do not adversely affect ultrasonic wave propagation, so high turbidity is not a problem. However, larger solids and voids (bubbles) can adversely affect sound propagation and should be avoided.

Does Neptune recommend a testing program?

Because all C&I MACH 10 meters have guaranteed accuracy for 10 years, Neptune recommends that regular sample/testing programs are not necessary. For utilities wishing to verify accuracy, Neptune recommends following the AWWA M6 standard for testing. While the AWWA M6 committee is still in the process of reviewing of the standard to add guidance pertinent to ultrasonic meters, we have created a Product Support Document (PSD) detailing some best testing practices for the C&I MACH 10 meters. This PSD can be found at neptunetg.com.

Register

Can the register be replaced on the C&I MACH 10 meter?

No. The electronic register of the C&I MACH 10 meter is permanently potted and sealed as part of the meter assembly for protection against moisture intrusion.

What is the significance of the serial number on the dial face?

This number will be used to identify the meter.



#winyourday
neptunetg.com

Neptune Technology Group
1600 Alabama Highway 229
Tallahassee, AL 36078
800-633-8754 f 334-283-7293



R900[®] Cellular Endpoint

What is the R900[®] cellular endpoint?

The Neptune R900 cellular endpoint is a meter interface unit that utilizes a cellular network to transmit data to Neptune[®] 360[™]. A network infrastructure is not required, eliminating the operational and capital burden that can come with having a traditional RF fixed network. The cellular endpoint supports targeted or full-scale deployments, providing a solution that can be tailored to each utility's unique needs.

What networks support the cellular endpoint?

The cellular endpoint is supported by the FirstNet[®] or Verizon[®] cellular network and their respective roaming partners to ensure robust coverage and secure, reliable delivery of AMI data.

What is FirstNet[®]?

FirstNet is the nationwide public safety broadband network built with and for First Responders (Primary) and those who support them (Extended Primary). Water utilities and their suppliers, such as Neptune Technology Group, are classified as Extended Primary.

What are the benefits of FirstNet?

FirstNet data is routed through a core network separated from commercial traffic allowing for:

- Data prioritization over commercial traffic
- Enhanced cybersecurity
- Protection from network congestion

FirstNet also provides augmented coverage with dedicated network resources and mobile cellular units that can be dispatched during disaster recovery to support agencies and organizations on FirstNet.

Why is the Neptune cellular endpoint able to use the FirstNet network?

The Neptune cellular endpoint and the Neptune 360 head-end system (HES) offer the utility a means of providing valuable information related to the state of water at a particular location. This includes information such as leak detection, reverse flow, continuous flow, etc. and meter reading for billing, enabling the utility to provide safe and dependable drinking water for their service territory.

How do I know whether I have FirstNet service in my area?

A coverage map can be used to identify service locations and is available on the FirstNet website: <https://www.firstnet.com/coverage.html>

How do I know whether I have Verizon service in my area?

A coverage map can be used to identify service locations and is available on the Verizon website: <https://www.verizon.com/coverage-map/>

Does the cellular endpoint require any programming?

No, the cellular endpoint auto-detects the type of encoded register it is connected to and only requires a magnet swipe along the endpoint housing to be activated.

With what registers will the cellular endpoint function?

The cellular endpoint is part of the Neptune R900[®] System and is compatible with the following encoder registers: Neptune[®] ARB[®] V, ProRead[™], ProCoder[™], E-CODER[®], MACH 10[®], KROHNE WATERFLUX 3070, Sensus (Invensys) ECR II, ECR III, ICE, iPerl, Electronic Register, OMNI, Hersey/Mueller Translator, Badger ADE, HR E|LCD, E-Series. Please refer to the latest product sheet for any updates to the compatibility list.



If I change the register attached to the cellular endpoint, do I need to wait to get an updated reading?

No, magnet swiping the endpoint will force it to interrogate the register and initiate network transmits of the data. Any subsequent readings after the magnet swipe will contain the latest reading from the new register.

How often is data sent from the cellular endpoint to Neptune 360?

The endpoint interrogates the meter register every 15 minutes. This data is stored in the cellular endpoint data log and is transmitted via the cellular network to Neptune 360 every six hours.

Does the endpoint allow for custom configuration of when and how often it sends data?

Yes, cellular endpoint users can now schedule the four daily cellular transmissions. These schedules are managed via the COMMS SCHEDULER function in Neptune 360.

Is a local data unload of the endpoint's data log supported?

No, the endpoint does not support a local data log unload. Instead, usage profile information can be accessed remotely from Neptune 360. Additionally, the endpoint stores up to 96 days of data to backfill readings into Neptune 360 in the event of a cellular network interruption. Once communication is restored, any readings that are stored and have not been transmitted will be queued and transferred via the cellular network so that there are no missed readings.

Does the cellular endpoint support mobile messages?

Yes, the cellular endpoint will transmit a mobile message every 30 seconds after 24 consecutive hours of unsuccessful cellular transmission. After a successful cellular transmission, the endpoint will stop transmitting the mobile messages.

How is the cellular endpoint activated?

The endpoint is shipped in a "sleep" mode and requires a magnet swipe along the left side of the endpoint to activate and begin transmitting meter reading data.

Is the battery replaceable on the cellular endpoint?

No, the cellular endpoint is fully potted for field reliability and there is no mechanism for field replacement of the battery.

How can I distinguish the cellular endpoint from other R900 System endpoints?

The cellular endpoint can be distinguished from other R900 System endpoints in the following ways:

- Pit units with an internal antenna have a distinct mounting arm with a circular hole through it that extends from the side of the endpoint's housing.
- Cellular endpoints have the cellular carrier abbreviation printed on the cover of the unit.
 - NOTE: Carrier abbreviations are FN=FirstNet, ATT=AT&T and VN=Verizon
- The label on the endpoint housing for all units includes the endpoint ID number and required regulatory information.

Can the cellular endpoint be connected to two separate registers?

No, the cellular endpoint does not support networking and can only be connected to a single register.

How do I verify that the cellular endpoint is connected to the cellular network once installed?

Connectivity can be verified by using the Neptune 360 Field Manager app. The Field Manager app will display information regarding the endpoint's cellular network status and meter reading from the connected register. This displayed information can be used to verify that you have properly wired the endpoint to the register along with a verification of cellular signal strength at the installation location.

How do I download and install the Field Manager to my iOS or Android device?

Contact Neptune Customer Support to obtain a license key and directions for installing the application to your device.



Is the Field Manager app required for installation?

No, the Field Manager app is not required for endpoint installation, but it is useful to verify a valid meter reading and good cellular network connectivity at the time of installation.

Why is the cellular endpoint transmitting all colons (:::)?

The endpoint is not detecting a register. Check all wiring connections and magnet swipe the endpoint to force a register interrogation.

What head-end software is supported by the cellular endpoint?

The cellular endpoint is supported by Neptune 360 only.

Does the cellular endpoint support remote firmware updates?

Yes, the endpoint supports remote firmware upgrades, initiated from Neptune 360, for future enhancements and bug-fixes.



© 2023 FirstNet and the FirstNet logo are registered trademarks of the First Responder Network Authority. All other marks are the property of their respective owners.

© 2023 Neptune Technology Group Inc. All Rights Reserved. The trademarks, logos and service marks displayed in this document herein are the property of Neptune Technology Group Inc., its affiliates or other third parties. Availability and technical specifications are subject to change without notice. Neptune engages in ongoing research and development to improve and enhance its products. Therefore, Neptune reserves the right to change product or system specifications without notice. FAQ CELLULAR ENDPOINT-US 08.23

#winyourday
neptunetg.com

Neptune Technology Group
1600 Alabama Highway 229
Tallahassee, AL 36078
800-633-8754 f 334-283-7293

APPENDIX 5

20150 Cumberland County Water District 01/01/2023 - 12/31/2023

Water Statistics (Ref Page: 30)

Description	Gallons (Omit 000's)	Percent
1. Water Produced, Purchased and Distributed		
2. Water Produced		
3. Water Purchased	226,675	
4. Total Produced and Purchased	226,675	
6. Water Sales:		
7. Residential	108,967	
8. Commercial	13,682	
9. Industrial	414	
10. Bulk Loading Stations		
11. Wholesale		
12. Public Authorities		
13. Other Sales (explain) DHSRP	14,634	
14. Total Water Sales	137,697	
16. Other Water Used		
17. Utility/water treatment plant		
18. Wastewater plant		
19. System flushing	2,512	
20. Fire department	37	
21. Other Usage (explain)		
22. Total Other Water Used	2,549	
24. Water Loss		
25. Tank Overflows	830	
26. Line Breaks	12,836	
27. Line Leaks		
28. Excavation Damages		
29. Theft		
30. Other Loss (Explain) Unknown Loss	72,763	
31. Total Water Loss	86,429	
Note: Line 14 + Line 22 + Line 31 must equal Line 4		
Water Loss Percentage		
Line 31 divided by Line 4		38.1290

PUBLIC SERVICE COMMISSION

Monthly Water Loss Report

Water Utility: Cumberland County Water District

For the Month of: November Year: 2024

LINE #	ITEM	GALLONS (Omit 000's)
1	WATER PRODUCED AND PURCHASED	
2	Water Produced	3,393
3	Water Purchased	12,477
4	TOTAL PRODUCED AND PURCHASED	15,870
5		
6	WATER SALES	
7	Residential	8,444
8	Commercial	2,111
9	Industrial	35
10	Bulk Loading Stations	
11	Wholesale	
12	Public Authorities	
13	Other Sales (explain) <u>DHSRP</u>	1,045
14	TOTAL WATER SALES	11,635
15		
16	OTHER WATER USED	
17	Utility and/or Water Treatment Plant	
18	Wastewater Plant	
19	System Flushing	162
20	Fire Department	2
21	Other Usage (explain) _____	
22	TOTAL OTHER WATER USED	164
23		
24	WATER LOSS	
25	Tank Overflows	
26	Line Breaks	
27	Line Leaks	1,485
28	Excavation Damages	
29	Theft	2,586
30	Other Loss (explain) <u>Unknown</u>	
31	TOTAL WATER LOSS	4,071
32		
33	Note: Line 14 + Line 22 + Line 31 MUST Equal Line 4	
34		
35	WATER LOSS PERCENTAGE	
36	(Line 31 divided by Line 4)	25.65%

PUBLIC SERVICE COMMISSION

Monthly Water Loss Report

Water Utility: Cumberland County Water District

For the Month of: October Year: 2024

LINE #	ITEM	GALLONS (Omit 000's)
1	WATER PRODUCED AND PURCHASED	
2	Water Produced	4,032
3	Water Purchased	14,371
4	TOTAL PRODUCED AND PURCHASED	18,403
5		
6	WATER SALES	
7	Residential	9,106
8	Commercial	1,881
9	Industrial	13
10	Bulk Loading Stations	
11	Wholesale	
12	Public Authorities	
13	Other Sales (explain) <u>Dale Hollow State Park</u>	1,375
14	TOTAL WATER SALES	12,375
15		
16	OTHER WATER USED	
17	Utility and/or Water Treatment Plant	
18	Wastewater Plant	
19	System Flushing	600
20	Fire Department	-
21	Other Usage (explain) _____	
22	TOTAL OTHER WATER USED	600
23		
24	WATER LOSS	
25	Tank Overflows	
26	Line Breaks	
27	Line Leaks	1,419
28	Excavation Damages	
29	Theft	
30	Other Loss (explain) <u>Unknown</u>	4,009
31	TOTAL WATER LOSS	5,428
32		
33	Note: Line 14 + Line 22 + Line 31 MUST Equal Line 4	
34		
35	WATER LOSS PERCENTAGE	
36	(Line 31 divided by Line 4)	29.50%

PUBLIC SERVICE COMMISSION

Monthly Water Loss Report

Water Utility: Cumberland County Water District

For the Month of: September Year: 2024

LINE #	ITEM	GALLONS (Omit 000's)
1	WATER PRODUCED AND PURCHASED	
2	Water Produced	3,731
3	Water Purchased	13,851
4	TOTAL PRODUCED AND PURCHASED	17,582
5		
6	WATER SALES	
7	Residential	9,106
8	Commercial	1,882
9	Industrial	166
10	Bulk Loading Stations	
11	Wholesale	
12	Public Authorities	
13	Other Sales (explain) <u>DHSRP</u>	1,375
14	TOTAL WATER SALES	12,529
15		
16	OTHER WATER USED	
17	Utility and/or Water Treatment Plant	
18	Wastewater Plant	
19	System Flushing	695
20	Fire Department	
21	Other Usage (explain) _____	
22	TOTAL OTHER WATER USED	695
23		
24	WATER LOSS	
25	Tank Overflows	
26	Line Breaks	1,340
27	Line Leaks	
28	Excavation Damages	
29	Theft	
30	Other Loss (explain) <u>Unknown</u>	3,018
31	TOTAL WATER LOSS	4,358
32		
33	Note: Line 14 + Line 22 + Line 31 MUST Equal Line 4	
34		
35	WATER LOSS PERCENTAGE	
36	(Line 31 divided by Line 4)	24.79%

#455

PUBLIC SERVICE COMMISSION

Monthly Water Loss Report

Water Utility:

For the Month of: Year:

LINE #	ITEM	GALLONS (Omit 000's)
1	WATER PRODUCED AND PURCHASED	
2	Water Produced	3,039
3	Water Purchased	12,874
4	TOTAL PRODUCED AND PURCHASED	15,913
5		
6	WATER SALES	
7	Residential	7,383
8	Commercial	2,194
9	Industrial	8
10	Bulk Loading Stations	
11	Wholesale	
12	Public Authorities	
13	Other Sales (explain) <u>DHSRP</u>	1,183
14	TOTAL WATER SALES	10,768
15		
16	OTHER WATER USED	
17	Utility and/or Water Treatment Plant	
18	Wastewater Plant	
19	System Flushing	302
20	Fire Department	12
21	Other Usage (explain) _____	
22	TOTAL OTHER WATER USED	314
23		
24	WATER LOSS	
25	Tank Overflows	
26	Line Breaks	1,067
27	Line Leaks	
28	Excavation Damages	
29	Theft	
30	Other Loss (explain) <u>Unknown</u>	3,764
31	TOTAL WATER LOSS	4,831
32		
33	Note: Line 14 + Line 22 + Line 31 MUST Equal Line 4	
34		
35	WATER LOSS PERCENTAGE	
36	(Line 31 divided by Line 4)	30.36%

PUBLIC SERVICE COMMISSION

Monthly Water Loss Report

Water Utility: Cumberland County Water District

For the Month of: June Year: 2024

LINE #	ITEM	GALLONS (Omit 000's)
1	WATER PRODUCED AND PURCHASED	
2	Water Produced	5,922
3	Water Purchased	16,258
4	TOTAL PRODUCED AND PURCHASED	22,180
5		
6	WATER SALES	
7	Residential	9,966
8	Commercial	2,846
9	Industrial	83
10	Bulk Loading Stations	
11	Wholesale	
12	Public Authorities	
13	Other Sales (explain) <u>DHSRP</u>	1,183
14	TOTAL WATER SALES	14,078
15		
16	OTHER WATER USED	
17	Utility and/or Water Treatment Plant	
18	Wastewater Plant	
19	System Flushing	427
20	Fire Department	
21	Other Usage (explain) _____	
22	TOTAL OTHER WATER USED	427
23		
24	WATER LOSS	
25	Tank Overflows	
26	Line Breaks	2,789
27	Line Leaks	
28	Excavation Damages	
29	Theft	
30	Other Loss (explain) <u>Unknown</u>	4,886
31	TOTAL WATER LOSS	7,675
32		
33	Note: Line 14 + Line 22 + Line 31 MUST Equal Line 4	
34		
35	WATER LOSS PERCENTAGE	
36	(Line 31 divided by Line 4)	34.60%

PUBLIC SERVICE COMMISSION

Monthly Water Loss Report

Water Utility: Cumberland County Water District

For the Month of: May Year: 2024

LINE #	ITEM	GALLONS (Omit 000's)
1	WATER PRODUCED AND PURCHASED	
2	Water Produced	4,075
3	Water Purchased	17,595
4	TOTAL PRODUCED AND PURCHASED	21,670
5		
6	WATER SALES	
7	Residential	9,609
8	Commercial	1,575
9	Industrial	16
10	Bulk Loading Stations	
11	Wholesale	
12	Public Authorities	
13	Other Sales (explain) <u>DHSRP</u>	1,744
14	TOTAL WATER SALES	12,944
15		
16	OTHER WATER USED	
17	Utility and/or Water Treatment Plant	
18	Wastewater Plant	
19	System Flushing	121
20	Fire Department	15
21	Other Usage (explain)	
22	TOTAL OTHER WATER USED	136
23		
24	WATER LOSS	
25	Tank Overflows	
26	Line Breaks	624
27	Line Leaks	
28	Excavation Damages	
29	Theft	
30	Other Loss (explain) <u>Unknown</u>	7,966
31	TOTAL WATER LOSS	8,590
32		
33	Note: Line 14 + Line 22 + Line 31 MUST Equal Line 4	
34		
35	WATER LOSS PERCENTAGE	
36	(Line 31 divided by Line 4)	39.64%

PUBLIC SERVICE COMMISSION

Monthly Water Loss Report

Water Utility: Cumberland County Water District

For the Month of: April Year: 2024

LINE #	ITEM	GALLONS (Omit 000's)
1	WATER PRODUCED AND PURCHASED	
2	Water Produced	3,963
3	Water Purchased	12,717
4	TOTAL PRODUCED AND PURCHASED	16,680
5		
6	WATER SALES	
7	Residential	8,469
8	Commercial	1,241
9	Industrial	13
10	Bulk Loading Stations	
11	Wholesale	
12	Public Authorities	
13	Other Sales (explain) <u>DHSRP</u>	1,439
14	TOTAL WATER SALES	11,162
15		
16	OTHER WATER USED	
17	Utility and/or Water Treatment Plant	
18	Wastewater Plant	
19	System Flushing	7
20	Fire Department	
21	Other Usage (explain) _____	
22	TOTAL OTHER WATER USED	7
23		
24	WATER LOSS	
25	Tank Overflows	
26	Line Breaks	966
27	Line Leaks	
28	Excavation Damages	
29	Theft	
30	Other Loss (explain) <u>Unknown</u>	4,545
31	TOTAL WATER LOSS	5,511
32		
33	Note: Line 14 + Line 22 + Line 31 MUST Equal Line 4	
34		
35	WATER LOSS PERCENTAGE	
36	(Line 31 divided by Line 4)	33.04%

PUBLIC SERVICE COMMISSION

Monthly Water Loss Report

Water Utility: Cumberland County Water District

For the Month of: March Year: 2024

LINE #	ITEM	GALLONS (Omit 000's)
1	WATER PRODUCED AND PURCHASED	
2	Water Produced	3,465
3	Water Purchased	12,405
4	TOTAL PRODUCED AND PURCHASED	15,870
5		
6	WATER SALES	
7	Residential	6,561
8	Commercial	702
9	Industrial	16
10	Bulk Loading Stations	
11	Wholesale	
12	Public Authorities	
13	Other Sales (explain) <u>DHSRP</u>	983
14	TOTAL WATER SALES	8,262
15		
16	OTHER WATER USED	
17	Utility and/or Water Treatment Plant	
18	Wastewater Plant	
19	System Flushing	20
20	Fire Department	
21	Other Usage (explain) _____	
22	TOTAL OTHER WATER USED	20
23		
24	WATER LOSS	
25	Tank Overflows	
26	Line Breaks	
27	Line Leaks	
28	Excavation Damages	
29	Theft	
30	Other Loss (explain) <u>Unknown</u>	7,588
31	TOTAL WATER LOSS	7,588
32		
33	Note: Line 14 + Line 22 + Line 31 MUST Equal Line 4	
34		
35	WATER LOSS PERCENTAGE	
36	(Line 31 divided by Line 4)	47.81%

PUBLIC SERVICE COMMISSION

Monthly Water Loss Report

Water Utility: Cumberland County Water District

For the Month of: February Year: 2024

LINE #	ITEM	GALLONS (Omit 000's)
1	WATER PRODUCED AND PURCHASED	
2	Water Produced	4,253
3	Water Purchased	9,133
4	TOTAL PRODUCED AND PURCHASED	13,386
5		
6	WATER SALES	
7	Residential	7,581
8	Commercial	777
9	Industrial	34
10	Bulk Loading Stations	
11	Wholesale	
12	Public Authorities	
13	Other Sales (explain) <u>DHSRP</u>	388
14	TOTAL WATER SALES	8,780
15		
16	OTHER WATER USED	
17	Utility and/or Water Treatment Plant	
18	Wastewater Plant	
19	System Flushing	77
20	Fire Department	
21	Other Usage (explain)	
22	TOTAL OTHER WATER USED	77
23		
24	WATER LOSS	
25	Tank Overflows	
26	Line Breaks	320
27	Line Leaks	
28	Excavation Damages	
29	Theft	
30	Other Loss (explain) <u>Unknown</u>	4,209
31	TOTAL WATER LOSS	4,529
32		
33	Note: Line 14 + Line 22 + Line 31 MUST Equal Line 4	
34		
35	WATER LOSS PERCENTAGE	
36	(Line 31 divided by Line 4)	33.83%

PUBLIC SERVICE COMMISSION

Monthly Water Loss Report

Water Utility: Cumberland County Water District

For the Month of: January Year: 2024

LINE #	ITEM	GALLONS (Omit 000's)
1	WATER PRODUCED AND PURCHASED	
2	Water Produced	1,095
3	Water Purchased	19,178
4	TOTAL PRODUCED AND PURCHASED	20,273
5		
6	WATER SALES	
7	Residential	10,300
8	Commercial	920
9	Industrial	25
10	Bulk Loading Stations	
11	Wholesale	
12	Public Authorities	
13	Other Sales (explain) <u>DHSRP</u>	494
14	TOTAL WATER SALES	11,739
15		
16	OTHER WATER USED	
17	Utility and/or Water Treatment Plant	
18	Wastewater Plant	
19	System Flushing	382
20	Fire Department	
21	Other Usage (explain) _____	
22	TOTAL OTHER WATER USED	382
23		
24	WATER LOSS	
25	Tank Overflows	
26	Line Breaks	583
27	Line Leaks	
28	Excavation Damages	
29	Theft	
30	Other Loss (explain) <u>Unknown</u>	7,569
31	TOTAL WATER LOSS	8,152
32		
33	Note: Line 14 + Line 22 + Line 31 MUST Equal Line 4	
34		
35	WATER LOSS PERCENTAGE	
36	(Line 31 divided by Line 4)	40.21%