

EXHIBIT

I

COMMONWEALTH OF KENTUCKY
BEFORE THE PUBLIC SERVICE COMMISSION

IN THE MATTER OF:

ELECTRONIC APPLICATION OF EAST)	
KENTUCKY POWER COOPERATIVE, INC. FOR)	
APPROVAL TO AMEND ITS ENVIRONMENTAL)	
COMPLIANCE PLAN AND RECOVER COSTS)	CASE NO.
PURSUANT TO ITS ENVIRONMENTAL)	2023-00177
SURCHARGE, AND FOR THE ISSUANCE OF)	
CERTIFICATES OF PUBLIC CONVENIENCE)	
AND NECESSITY AND OTHER RELIEF)	

DIRECT TESTIMONY OF LAURA LEMASTER
ON BEHALF OF EAST KENTUCKY POWER COOPERATIVE, INC.

Filed: June 30, 2023

1 **I. INTRODUCTION**

2 **Q. PLEASE STATE YOUR NAME, TITLE AND BUSINESS ADDRESS.**

3 A. Laura LeMaster, my business address is East Kentucky Power Cooperative
4 (“EKPC”), 4775 Lexington Road, Winchester, KY 40391. I am currently the
5 Supervisor of Construction and Capital Projects at East Kentucky Power.

6 **Q. PLEASE DESCRIBE YOUR EDUCATION AND PROFESSIONAL**
7 **EXPERIENCE.**

8 A. I received my Bachelors and Masters Degrees in Civil Engineering from the
9 University of Kentucky and I am a registered Professional Engineer in the
10 Commonwealth of Kentucky. My professional experience includes time spent
11 working as a project engineer at Poage Engineers & Associates, a structural
12 engineering firm, and serving as a project engineer for Tetra Tech providing
13 consulting services to clients on water and wastewater projects. I joined EKPC in
14 2016, working as an engineer in the Production Engineering department, where I
15 provided technical assistance to EKPC Production Facilities, including the
16 execution of construction projects. In 2017, I joined the Construction and Capital
17 Project Department. In 2023, I was promoted to the Supervisor of Construction and
18 Capital Projects.

19 **Q. PLEASE DESCRIBE YOUR DUTIES AS SUPERVISOR OF THE**
20 **CONSTRUCTION AND CAPITAL PROJECT DEPARTMENT FOR EKPC.**

21 A. As the Supervisor of Construction and Capital Projects, I am responsible for
22 supervising the successful execution of capital construction projects which are
23 executed by the Construction and Capital Project Management Department.

1 **Q. HAVE YOU TESTIFIED BEFORE THE KENTUCKY PUBLIC SERVICE**
2 **COMMISSION BEFORE? IF SO, IN WHAT CASES?**

3 A. Yes, I provided written testimony and testified in person at a hearing held on
4 January 24, 2023 in Case No. 2022-00314, *Electronic Application of East Kentucky*
5 *Power Cooperative, Inc. for a (1) Certification of Public Convenience and*
6 *Necessity for the Construction of Transmission Facilities in Madison County,*
7 *Kentucky; (2) Declaratory Order Confirming that a Certificate of Public*
8 *Convenience and Necessity is not Required for Certain Facilities,* (Ky. PSC Feb.
9 23, 2023).

10 **Q. WHAT IS THE PURPOSE OF YOUR TESTIMONY IN THIS**
11 **PROCEEDING?**

12 A. The purpose of my testimony is to discuss EKPC's planning, scoping, and
13 engineering efforts for the Cooper Former Impoundment ("CFI") Closure in Place
14 Project ("CIP") at EKPC's John Sherman Cooper Power Station ("Cooper
15 Station").

16 **Q. ARE YOU SPONSORING ANY EXHIBITS?**

17 A. Yes, included with my testimony as Exhibit LL-1 is the Cooper Former
18 Impoundment Project Scoping Report.

19 **Q. WERE THE EXHIBITS THAT ARE ATTACHED TO YOUR TESTIMONY**
20 **PREPARED BY YOU OR SOMEONE WORKING UNDER YOUR**
21 **SUPERVISION?**

22 A. Yes.

23 **II. COOPER FORMER IMPOUNDMENT PROJECT**

1 **Q. PLEASE BRIEFLY DESCRIBE COOPER STATION AND THE FORMER**
2 **IMPOUNDMENT.**

3 A. Cooper Station is located just outside of Somerset, Kentucky in Pulaski County.
4 Topography in the Somerset area is described as rolling, upland karst plain,
5 meaning that the area is known for karst features including fractured rock, sink
6 holes, and springs. Karst activity has been noted on Cooper Station property.
7 Cooper Station is a coal-fired electric generating facility with two electric
8 generating units, the first unit achieving commercial operation in 1965 and the
9 second in 1969. Cooper Station still operates both units today and produces a total
10 of 341 megawatts. Coal combustion residual by-products (“CCB”) including fly
11 ash and bottom ash generated by Cooper Units 1 and 2 were sluiced to an ash pond
12 located to the west of the generating facility near Highway 1247. This ash pond is
13 now referred to as the CFI. In the early 1990’s Units 1 and 2 moved to a dry ash
14 handling system, at that time dry CCB material from Units 1 and 2 to grade the CFI
15 to the surface elevations onsite today, and vegetation grew on the surface of the
16 CFI.

17 **Q. PLEASE BRIEFLY DESCRIBE THE COOPER STATION FORMER**
18 **IMPOUNDMENT PROJECT AND ITS OBJECTIVE.**

19 A. The CFI project will include the consolidation of CCB material from 65 acres to
20 approximately 40 acres. The consolidation of the material will allow for the
21 installation of perimeter storm water controls to divert water to the newly
22 constructed storm water basins. The consolidated 40 acres of CCB will be covered
23 with a final cover system which includes a 40-mil thick geomembrane liner overlain

1 by two-feet of soil and new vegetation. The objective of this project is to close the
2 CFI in a manner that is safe and environmentally responsible as well as affordable
3 to EKPC owner-members.

4 **Q. PLEASE DESCRIBE THE CFI PROJECT AND HOW EKPC IS PLANNING**
5 **ON CLOSING THE CFI.**

6 A. The CFI CIP Project includes the consolidation of the 65 acre CFI to approximately
7 40 acres. It will include the construction of a final capping system which consists
8 of a 40-mil geomembrane line overlain by two-feet of soil and vegetation. The
9 project will also include the construction of perimeter storm water ditches and
10 storm water basins for long term storm water control. Construction on the CFI CIP
11 Project would begin with the construction of the storm water control basins,
12 followed by the construction of the temporary storm water management facilities.
13 The storm water basins are proposed to be constructed utilizing both onsite material
14 and off site borrow material for the construction of the embankment and for the
15 clay liner system for the ponds. Based on the current design, the southern storm
16 water basin would be classified as a low hazard potential dam by the Kentucky
17 Division of Water (“KDOW”) and would require necessary permitting. Once the
18 storm water basins are constructed, a temporary storm water collection system
19 would be installed to reduce the amount of run on to the CFI during construction.
20 This temporary storm water collection system includes the construction of
21 temporary containment berms and pumping systems to the northern storm water
22 basin for discharge through a KPDES outfall location. The southern storm water

1 berm is proposed to be utilized during construction as a sedimentation basin for
2 storm water that falls within the disturbance limits during construction.

3 Prior to beginning excavation, dewatering will commence to allow for safe
4 execution of the CCB consolidation and the associated excavation, and will
5 continue as necessary through the CCB grading activities. The dewatered flow will
6 be treated as necessary to meet the KPDES outfall requirements. The reduction of
7 the footprint of the CFI would be accomplished by excavation of the CCB from the
8 perimeter margins of the CFI and the consolidation of the CCB within the smaller
9 footprint (approximately 40 acres). After the CCB footprint is reduced, site grading
10 of the new fill area would occur to allow for surface water to drain from the final
11 cover system to the new ditches and storm water basins.

12 Upon completion of the CCB site grading, the final cap system will be installed.
13 The final cap system proposed meets the substantive design requirements of the
14 original 2015 Coal Combustion Residual (“CCR”) Rule, which have not changed
15 in the EPA’s recently proposed amendments to the 2015 CCR Rule. The final cap
16 system includes a 40-mil geomembrane, with a geotextile cushion overlain by two-
17 feet of a soil protection layer. The soil protection layer will include topsoil to allow
18 for native grasses. The cover system would allow for surface water drainage from
19 the cap system into the perimeter storm water ditches. The two-foot protective layer
20 will require the purchase of offsite borrow material, and the hauling of this material
21 to the site.

22 Once the cap system is complete, the project area will be restored, and the
23 temporary storm water system will be removed.

1

2 Exhibit LL-1, the Cooper Former Impoundment Project Scoping Report provides
3 additional details associated with the proposed construction.

4 **Q. WHY IS EKPC CHOOSING THE ALTERNATIVE OF CLOSURE IN**
5 **PLACE FOR THE CFI PROJECT?**

6 A. EKPC is choosing the Closure in Place alternative for the CFI as it is the reasonable,
7 least-cost alternative to achieve the project objectives for closure of the CFI in a
8 manner that is safe and environmentally responsible as well as affordable to
9 EKPC's owner-members. Although Alternative One was the least cost alternative,
10 it did not fully address the risks that EKPC has identified or meet the project
11 objectives.

12 **Q. WERE YOU INVOLVED IN THE PLANNING, SCOPING, AND**
13 **ENGINEERING FOR THE CFI PROJECT FROM ITS BEGINNING?**

14 A. Yes. I was involved in the planning, scoping and engineering for the CFI Project.
15 This work included the review and evaluation of different alternatives, as discussed
16 in my testimony, to achieve the objective of closure of the CFI. This included high
17 level scoping of the alternatives, evaluation of alternatives from a cost and
18 constructability perspective. Upon selection of the CIP alternative, I oversaw the
19 development of the proposed scope for the CFI CIP Project, including development
20 of the cost estimate and schedule and the Project Scoping Report included in my
21 testimony as Exhibit LL-1.

22 **Q. DID YOU PREPARE OR HAVE PREPARED BY SOMEONE ELSE A**
23 **SCOPING REPORT FOR THE CFI PROJECT?**

1 A. Yes. A Project Scoping Report was developed by Geosyntec Consultants for the
2 CFI Project and is attached as Exhibit LL-1 to my testimony.

3 **Q. DID EKPC REVIEW OTHER ALTERNATIVES TO THE CIP THAT WAS**
4 **CHOSEN?**

5 A. Yes, EKPC and Geosyntec reviewed and evaluated four (4) closure alternatives
6 prior to selection of the CIP alternative proposed.

7 **Q. PLEASE DESCRIBE THE ALTERNATIVES TO THE CFI PROJECT**
8 **THAT WERE CONSIDERED.**

9 A. The Geosyntec report attached as Exhibit LL-1, discusses these alternatives in
10 detail and I will briefly describe each of the four (4) alternatives below:

11 **Alternative 1** – Monitor and Mitigate. This alternative includes the clearing of
12 woody vegetation and revegetation of the CFI. It would also include a monitoring
13 program including visual inspections of the CFI. Any items noted during
14 inspections would be mitigated or remediated as required on a case-by-case basis.

15 **Alternative 2** – Closure in Place. This alternative is discussed in depth within my
16 testimony.

17 **Alternative 3** – Closure by Removal. This alternative includes the excavation of
18 the CCB material in the CFI, hauling and placement and compaction in the Cooper
19 Station onsite CCR landfill. This alternative would include a required horizontal
20 expansion of the Cooper Station CCR Landfill for adequate storage capacity of
21 material removed from the CFI. This alternative would also include the restoration
22 of the CFI area to as close to preconstruction conditions as practicable.

1 **Alternative 4** – Closure in Place with in Situ Stabilization – This alternative
2 includes the closure in place of the CFI outlined in Alternative 2, with the addition
3 of in Situ Stabilization (“ISS”). ISS is the construction of overlapping ISS grout
4 columns at the base of the CFI above any karst locations. ISS equipment mixes the
5 CCB within the CFI with a cementitious mix that is designed to increase strength,
6 and reduce hydraulic conductivity, with the intent of creating a CCB/cement
7 monolith at the base of the area. This alternative was explored due to the karst
8 topography.

9 **Q. WHY WERE THESE ALTERNATIVES NOT CHOSEN BY EKPC?**

10 A. The Closure in Place alternative was selected as the least cost, reasonable
11 alternative evaluated. Alternative 1 - Monitor and Mitigate had a lower overall cost,
12 however, EKPC determined that this alternative did not provide the adequate
13 environmental protection necessary. Alternative 2, 3 and 4 all met the substantive
14 technical requirements for closure under the original 2015 CCR Rule, and afforded
15 the environmental protection EKPC deemed necessary for the CFI Project. Today’s
16 industry standard for closure of a current or former impoundments is the original
17 2015 CCR Rule, Alternative 2 (Closure in Place) and Alternative 3 (Closure by
18 Removal) considered by EKPC are industry standard closure alternatives that are
19 being executed throughout the industry and are specifically referenced in the
20 original 2015 CCR Rule as closure alternatives. With Alternatives 2, 3 and 4
21 meeting the project objective, the least cost alternative of the three alternatives,
22 which is Alternative 2, Closure in Place, was selected.

23 **Q. PLEASE EXPLAIN THE NEED FOR THIS PROJECT IN DETAIL.**

1 A. The need for this project is environmentally driven, and is covered in detail in Mr.
2 Purvis' testimony. Ultimately the need for this project is to protect the environment
3 and to maintain compliance with environmental regulations.

4 **Q. PLEASE DESCRIBE WHY THIS PROJECT WILL NOT RESULT IN**
5 **WASTEFUL DUPLICATION OF SERVICES.**

6 A. EKPC asserts that the proposed CFI Project will not result in wasteful duplication,
7 as EKPC has shown that a thorough evaluation of reasonable alternatives has been
8 considered and that the reasonable, least-cost alternative was selected and is
9 proposed herein.

10 **Q. PLEASE DESCRIBE THE CONSTRUCTION TIMELINE FOR THE CFI**
11 **PROJECT.**

12 A. The proposed schedule for the CFI Project is included in Appendix D of the
13 Scoping Report included as Exhibit LL-1. The proposed schedule includes detailed
14 design, permitting, and bidding to occur through the end of 2024. The CFI Project
15 has a two-year construction duration, which would begin in the Spring of 2025 and
16 be completed in late 2026.

17 **Q. PLEASE DESCRIBE THE IMPACT TO THE PUBLIC THIS PROJECT**
18 **WILL HAVE AND DOES EKPC HAVE PLANS TO MINIMIZE THESE**
19 **IMPACTS?**

20 A. All heavy construction activities associated with this project will occur on EKPC
21 property. There will be additional truck traffic for material deliveries, importing
22 fill, rock deliveries and ancillary needs during construction. The majority of these
23 deliveries will be for importing fill and will occur in the 2026 construction season.

1 The imported fill deliveries will reach a maximum of 200 trucks per day. EKPC
2 plans to utilize a haul program similar to the program utilized in the Dale Station
3 Closure project, which included GPS monitoring to confirm adherence to traffic
4 safety, including speeding and adherence to haul route. This is to protect safety of
5 the Project work force and the public.

6 In detailed design, EKPC will also incorporate dust mitigation and fugitive
7 dust requirements to minimize fugitive dust at the site during construction, this
8 likely will include the use of water trucks.

9 **Q. PLEASE PROVIDE A COST ESTIMATE FOR EACH ELEMENT OF THE**
10 **PROJECT.**

11 A. The estimated cost of the CFI Project is \$47.2 million. A more detailed cost
12 breakdown is included in Appendix E of the Scoping Report, which is attached as
13 Exhibit LL-1.

14 **Q. DO YOU BELIEVE THAT THE \$47.2 MILLION DOLLAR COST**
15 **ESTIMATE FOR THE COOPER STATION IMPOUNDMENT PROJECT**
16 **IS A REASONABLE ESTIMATE?**

17 A. Yes. Geosyntec developed the cost estimate for the CFI Project based on the
18 proposed design. This cost estimate includes the cost for construction, engineering
19 and construction oversight, and owner's cost. Included in the cost estimate is fifteen
20 percent (15%) contingency, which is industry standard. The estimated cost for
21 recovery will be \$44.7 million. The recovery cost is the estimated spend after the
22 receipt of the Order, EKPC is not requesting recovery on funds previously spent on
23 the project.

1 **Q. WILL THERE BE ANY ONGOING OPERATIONS AND MAINTENANCE**
2 **EXPENSES FOR THE PROJECT?**

3 A. Yes, the estimated annual operations and maintenance expenses for the CFI is
4 \$65,000 per year. This includes cover, vegetation and miscellaneous maintenance,
5 mowing, and cost for inspections.

6 **Q. WHAT IS THE TIMELINE FOR COMPLETION OF THE PROJECT?**

7 A. The planned construction completion is the end of the year 2026. Project Closeout
8 would occur in early 2027.

9 **IV. CONCLUSION**

10 **Q. PLEASE SUMMARIZE YOUR TESTIMONY.**

11 A. The objective of this CFI project is to close the CFI in a manner that is safe and
12 environmentally responsible as well as affordable to EKPC owner-members. EKPC
13 evaluated alternatives, and selected the least-cost, reasonable alternative of closure
14 in place to meet the project objectives. The CFI Project consists of the consolidation
15 of CCB material to allow for the installation of storm water controls and to
16 construct a CCR Rule technically compliance capping system.

17 **Q. DOES THIS CONCLUDE YOUR TESTIMONY?**

18 A. Yes.

EXHIBIT

LL-1



Prepared for

East Kentucky Power Cooperative
Cooper Power Plant Road
Somerset, KY 42501

PROJECT SCOPING REPORT

COOPER FORMER IMPOUNDMENT

JOHN SHERMAN COOPER POWER STATION
Somerset, Kentucky

Prepared by

Geosyntec 
consultants

engineers | scientists | innovators

1 McBride and Son Center Drive, Suite 202
Chesterfield, Missouri 63005

GLP8015

June 2023

TABLE OF CONTENTS

Executive Summary	iii
SECTION 1 Introduction	1-1
1.1 Background.....	1-1
1.2 Objectives	1-1
1.3 Report Credentials	1-1
SECTION 2 Site Setting And Background.....	2-1
2.1 Site Location and Physiography	2-1
2.2 History	2-1
SECTION 3 Site Inspection and Investigations.....	3-1
3.1 Site Inspection.....	3-1
3.2 Site Investigations.....	3-1
SECTION 4 Conceptual Site Model.....	4-1
SECTION 5 Alternatives Assessment	5-1
5.1 Alternative Descriptions	5-1
5.2 Comparative Alternatives Assessment	5-1
5.2.1 Cost.....	5-1
5.2.2 Environmental Impacts.....	5-2
5.2.3 Constructability	5-3
5.2.4 Schedules	5-3
5.2.5 Human Health & Safety	5-4
5.2.6 Potential Permitting Requirements Comparison	5-5
5.3 Comparative Assessment Summary	5-6
5.4 Selected Alternative.....	5-6
SECTION 6 Proposed Mitigation to Project Risks.....	6-1
SECTION 7 Permitting Assessment.....	7-1
SECTION 8 Design Documents	8-1
8.1 Closure Design Description	8-1
8.1.1 Stormwater Management.....	8-1
8.1.2 Dewatering.....	8-2
8.1.3 Cover System.....	8-2
8.2 Geotechnical Considerations	8-3
8.2.1 Slope Stability.....	8-3
8.2.2 Settlement	8-3
8.3 Hydraulic and Hydrologic Considerations	8-3

8.3.1	Perimeter Stormwater System	8-3
8.3.2	Contact Stormwater	8-3
8.3.3	Post-Closure Stormwater Management	8-4
8.4	Design Drawings.....	8-5
8.5	Project Schedule	8-5
8.6	Construction and O&M Cost Estimate	8-6
8.7	Construction Project Cash Flow	8-6
8.8	Construction Methods.....	8-6
8.9	Summary	8-7
SECTION 9 References		9-1

LIST OF FIGURES

Figure ES-1	Site Plan
Figure ES-2	CFI Location Map
Figure 3-1	Investigation Locations

LIST OF TABLES

Table 5-1	Summary of Alternative Cost Estimates
Table 5-2	Summary of Environmental Long-Term Impact Risks
Table 5-3	Summary of Environmental Impact Risks During Construction
Table 5-4	Alternative Schedules
Table 5-5	Safety Short-Term Safety Risks
Table 5-6	Safety Long-Term Safety Risks

LIST OF APPENDICES

Appendix A	Conceptual Site Model
Appendix B	Permit Matrix
Appendix C	Design Drawings
Appendix D	Construction Schedule
Appendix E	Capital and O&M Cost Estimate / Project Cash Flow Chart

EXECUTIVE SUMMARY

Geosyntec Consultants, Inc. (Geosyntec) developed a Project Scoping Report (PSR) to support the selection of the best long-term closure alternative that minimizes risk to the environment and cost at the East Kentucky Power Cooperative, Inc. (EKPC) Cooper Former Impoundment (CFI). The CFI contains coal combustion byproducts (CCB) from the sluicing of CCB from the John Sherman Cooper Power Station (“Cooper Station”).

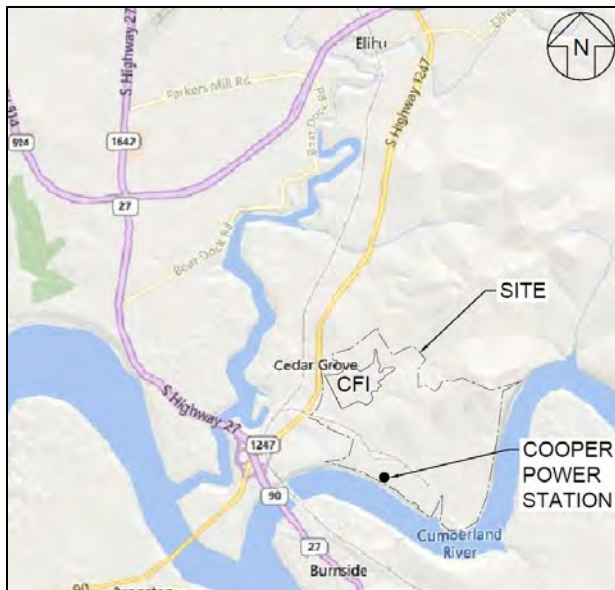

Figure ES-1 Site Location Map

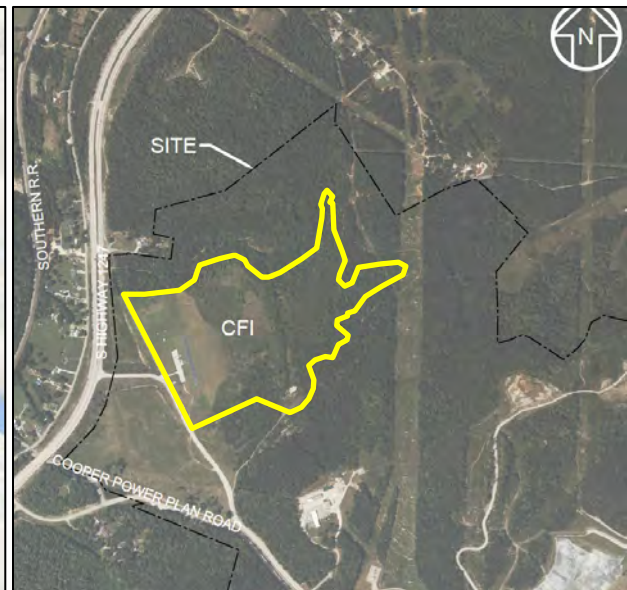

Figure ES-2 CFI Location Map

The CFI is located at the EKPC Cooper Station and is shown on **Figure ES-1** and **Figure ES-2**. CCB is retained by a 1,600-ft long, 40-ft high (maximum) former dam. The surface area of the CFI is approximately 65 acres. The CFI ceased operation in the early 1990s.

The primary risks at the site for release of CCBs are through rainfall infiltration through karst features into groundwater, from surface runoff, or from fugitive dust inhalation. All these risks were assessed and are addressed in this PSR.

EKPC proposes to close the CFI using the closure in place (CIP) method. This method was selected after evaluating four options/alternatives. The following summarizes the four alternatives evaluated:

1. Alternative 1 - Monitor and Mitigate, including weekly dam inspections, clearing of woody vegetation and revegetation, periodic inspections, and limiting public access. This alternative was estimated at a cost of \$3,500,000 with a construction duration of approximately 3.5 months. Alternative 1 is the least costly but has the highest long-term risks to the environment.

2. Alternative 2 - CIP includes reduction/consolidation of the total area of CCB and construction of a new final cover system to eliminate surface exposure and minimize infiltration into the CCB. This will include perimeter ditches and stormwater basins as long-term stormwater controls. The final cover system includes a 40-mil thick geomembrane overlain by two-feet of soil and new grassland/native vegetation. This alternative was estimated to have a cost of \$47,200,000 with a construction duration of approximately 21 months. Alternative 2 (CIP) has a moderate cost and has the lowest short-term risks of the closure construction alternatives. Alternative 2 has slightly higher overall long-term risk than Alternative 4 because adding ISS (as described below) may further reduce the risk of infiltration through karst features.
3. Alternative 3 - Closure by Removal (CBR) includes removal of CCB, disposal in an expansion of the existing onsite Coal Combustion Residual (CCR) Landfill, and restoration of the CFI area to as close to preconstruction conditions as practicable. This alternative was estimated at a cost of \$113,600,000 with a construction duration of approximately 79 months. Alternative 3 is the most extensive, highest cost alternative, and poses the highest short-term risk. However, Alternative 3 has lower long-term risks compared to the other alternatives.
4. Alternative 4 - In Situ Stabilization (ISS) includes construction of overlapping ISS columns at the base of the CFI above karst locations. This variation would be combined with Alternative 2 (CIP with a new final cover system). This alternative was estimated at a cost of \$57,900,000 with a construction duration of approximately 21 months. Alternative 4 has a significantly higher cost and additional construction work during the winter months, but with the same overall schedule as Alternative 2. Alternative 4 has a slightly higher short-term risk due to increased construction tasks but also has a slightly lower long-term risk than Alternative 2.

Alternative 2 was selected because it provides a reasonable option to close the CFI safely and effectively, and it is the least-cost reasonable alternative that minimizes risk to the environment.

Geosyntec conducted a thorough evaluation of the site conditions to develop mitigation alternatives. The predesign work included:

- Documentation review.
- Site inspection.
- Site investigations including completing soil and bedrock borings, installation and monitoring of piezometers, and geophysical investigations to assess karst conditions.
- Topographic survey.
- Alternatives analysis that developed the overall scope of the mitigation options, cost, short- and long-term environmental impacts, constructability, schedule, health and safety risks, potential permitting requirements, and implementation risks.

A thorough cost analysis was completed. To develop a reasonably accurate cost estimate, a 90 percent design of Alternative 2 was completed. The design addressed:

- Reduction of the areas of CCB to reduce the size and cost of the final cover system.
- Inclusion of a geomembrane covered with soil and vegetation to minimize infiltration and reduce long-term maintenance.
- Stability and settlement of the final cover system.
- Stormwater drainage system.
- Construction sequencing to reduce the potential for release of CCB.
- Potential permit requirements.
- Cost estimate.

SECTION 1

INTRODUCTION

1.1 Background

This Project Scoping Report summarizes the selected method of closure (Closure In Place, or “CIP”) for the Cooper Former Impoundment (CFI) and provides an executive summary, discussion of alternatives considered, report describing the design information, and conclusions. The Project Scoping Report has been prepared by Geosyntec Consultants, Inc. (Geosyntec) for EKPC. The Cooper Former Impoundment may be referred to herein as the CFI or the Site.

1.2 Objectives

The objective of this PSR is to provide data and preliminary design concepts to facilitate the selection of the most favorable, long-term alternative that meets EKPC’s project goals of a closure alternative that minimizes the risk to the environment and cost.

1.3 Report Credentials

This report was prepared by Geosyntec Consultants of St. Louis, Missouri, Chicago, Illinois, Austin, Texas and Kennesaw, Georgia.

SECTION 2

SITE SETTING AND BACKGROUND

2.1 Site Location and Physiography

Cooper Station is located in Pulaski County near Somerset and Burnside, Kentucky. The CFI site, at Cooper Station, is located roughly three quarters of a mile to the northwest of Cooper Station's power generation facilities and is bound on the west by Kentucky Route 1247, on the east by transmission lines, on the north by dense woods and multiple residences, and to the south by the Cooper Power Plant Road.

The topography can be described as a rolling, upland karst plain with drainage occurring primarily in the subsurface with the exception of major surface water drainages such as large creeks and rivers. The topography becomes very steep near Lake Cumberland, with pronounced cliff-forming limestone outcrops. Topographic relief in the vicinity of the site is approximately 175 feet, with elevations ranging from 900 ft MSL in the upland areas to approximately 725 ft MSL at the normal pool elevation of Lake Cumberland. The topography of the CFI is relatively flat at around elevation 850 ft. Bedrock outcropping in the area is generally composed of Mississippian-age carbonate rocks such as limestone and dolomite.

2.2 History

The CFI dam was constructed in 1977 to contain the approximately 65-acre CFI which received sluiced Coal Combustion Byproducts (CCB) that discharged through a pipe system. This area was historically a valley with the grade rising to the east. The CFI operated as a CCB pond from 1977 until the early 1990s when the Cooper Station switched to dry stacking in the onsite Coal Combustion Residual (CCR) Landfill. Following the stoppage of sluicing to the former impoundment, dry CCB material was placed to bring the former impoundment to the current elevations and the inflow pipe to the spillway was sealed to preclude flow of water below the surface with no water being impounded at the CFI. The CFI does not have an engineered cover system or soil cap and the ground surface primarily consists of vegetation growing directly from the CCB. Following these activities, the dam was removed from the Kentucky Division of Water (KDOW) active inventory list.

SECTION 3

SITE INSPECTION AND INVESTIGATIONS

3.1 Site Inspection

A site inspection was completed that included the former dam, the former impoundment surface area, and previously identified upgradient karst features. A document review was also completed that included all available information.

Geosyntec concluded that the former dam was not in immediate risk of slope stability failure. A slope stability assessment of the existing conditions at the former dam produced factors of safety that exceed the target factors of safety identified as industry standards.

Several karst surface features were observed in the areas upgradient of the CFI during the site inspection. These features ranged in size from a few to several feet in diameter, and can generally be described as swallets, which are essentially small sinkholes into which surface water flows.

The team visited several springs located near the Pitman Creek cove approximately 2,500 feet west of the CFI. Historical observations during the period of operation of the CFI reported that CCB material had been discharged from, or in the vicinity of, some of these springs. However, at the time of Geosyntec's site inspection, there was no evidence of CCB material at any of the spring heads in the vicinity of Pitman Creek. It appears that the CCB material observed in the vicinity of Pitman Creek during the operation of the CFI was likely transported via karst conduits under the increased hydraulic head of the impoundment caused by the active sluicing of CCB.

3.2 Site Investigations

Site investigations were completed to provide a full characterization of the site geology, hydrogeology, and subsurface conditions to enable assessment of the potential closure alternatives. The investigations consisted of Closed-Circuit Television (CCTV) video inspection of the outfall pipe system, geotechnical and hydrogeological investigations, and a karst geophysical investigation.

- The Principal Spillway Outlet Structure is located on the upstream slope of the former dam with an outlet pipe that extends through the dam and was previously connected to the existing outlet system through KYTC Route 1247. A CCTV investigation was completed to assess the integrity of the outlet pipe for abandonment or utilization in alternative design scenarios. Following the inspection, the portion of the outlet pipe system through the former dam was abandoned along with the Principal Spillway Outlet Structure by filling with bentonite-grout. The remainder of the outfall pipe system is active and will be utilized in the final site closure. Clearing and lining of segments will be assessed.

- A karst geophysical investigation was completed to estimate the current distribution and extent of karst features within the CFI. Apparent karst features were identified using a combination of microgravity survey and electrical resistivity imaging. The investigation indicated discrete low-gravity anomalies suggesting likely karst conditions. The anomalies were observed at depths as shallow as just below the base of the CFI, while others were located at depths of 100 feet or more below the bottom of the CFI. Seventy percent of the total area of potential karst features appear to be near or within ten feet of the bottom of the CFI. Thirty percent of the features appear to be 20 feet or more below the CFI bottom. Confirmatory drilling and collection of rock cores indicated that most of these features were either filled in paleo-sinkholes or generally small karst solution features in the bedrock.
- The comprehensive geotechnical and hydrogeological investigations included geotechnical borings in the former dam, within the areas of the future planned stormwater basins, within the CFI, and along the perimeter of the CFI. Multiple test pits and hand augers were also completed to delineate the perimeter of the CCB within the CFI. A total of 23 piezometers were installed for the geotechnical and hydrogeological investigations to estimate the phreatic conditions at the site and as confirmation borings for the geophysical investigation. Geosyntec developed a conceptual site model based on the results of this investigation, which is presented in the following section of this report.

S:\COMPANY\PROJECTS_POST_2014\GLP8015_EKPC_COOPER_LEGACY_POND_F&C\900 - CAD\900% PLANSET\FIGURES\GLP8015-001 FIGURE 3-1_06152022 - Last Saved by: DWatkins on 5/31/23

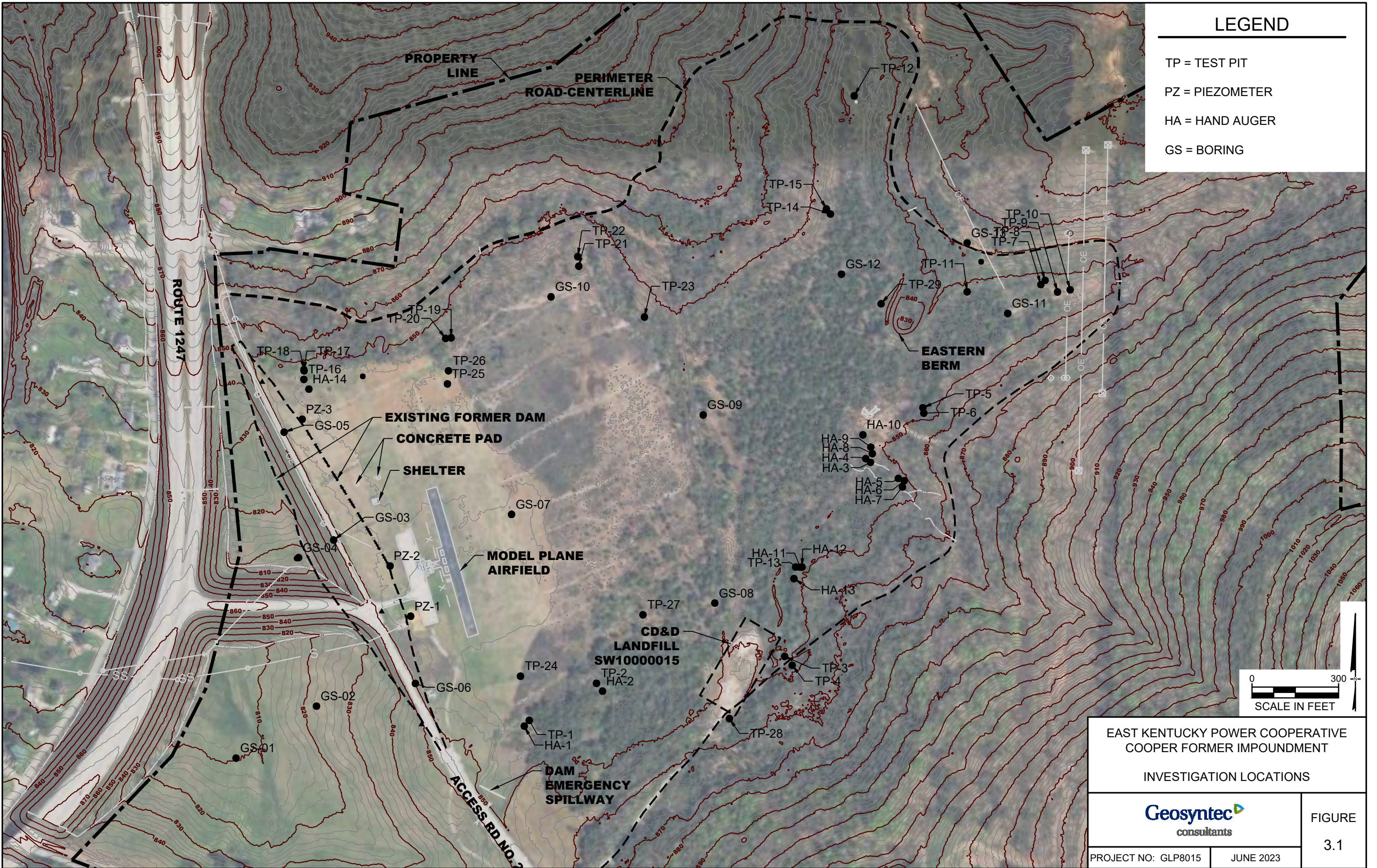

LEGEND

- TP = TEST PIT
- PZ = PIEZOMETER
- HA = HAND AUGER
- GS = BORING

EAST KENTUCKY POWER COOPERATIVE
 COOPER FORMER IMPOUNDMENT

INVESTIGATION LOCATIONS

		FIGURE 3.1
PROJECT NO: GLP8015	JUNE 2023	

SECTION 4

CONCEPTUAL SITE MODEL

The CFI is underlain by a mantle of clayey residual soils of varying thickness, formed by the in-place weathering of the native limestone bedrock. The clay soil is directly underlain by the Ste. Genevieve Limestone, followed by the limestone and dolomite of the St. Louis Formation, and then by the dolomite, limestone, shale, and siltstone of the Salem and Warsaw Formations. The carbonate rocks of these formations are affected by karst dissolution, which accounts for the primary groundwater flow system in the region. Typical karst features are common in the vicinity of the CFI, including sinkholes, swallets, and springs.

Groundwater flow is directed through the karst system by underlying low-permeability layers, or facies in the rock formations, or at the contact between rock formations, such as between the St. Louis and the underlying lower permeability Salem/Warsaw Formations. These low-permeability layers direct the flow toward springs, where the groundwater then discharges to the surface. The key elements of the conceptual site model (CSM) included in **Appendix A** are:

- Precipitation enters the system from the upland areas to the north and east in the form of rain and snow melt. This water flows over short distances along the surface as runoff until it enters karst features (sinkholes, swallets, etc.) and moves in the subsurface as groundwater;
- The uppermost aquifer in the vicinity of the CFI occurs mainly in the solutioned karst bedrock and is unconfined. A phreatic surface exists within the CFI that represents a perched zone of interstitial porewater in the CCB, resulting from the capillary forces of the CCB as well as the low-permeability clay soils underlying the CFI;
- The uppermost aquifer beneath the CFI is approximately 30 to 50 feet below the bottom of the CCB within the unit. Water levels respond rapidly to significant rain events, as is typical of many karst systems; however, based on data collected to date, the groundwater does not rise above the bottom of the CFI's native clay foundation soils;
- The groundwater flows mainly via solution enhanced fractures and conduits in a stair-stepping pattern, moving laterally atop low permeability layers and vertically where the vertical joints and features are present;
- Features beneath the CFI identified as low-gravity anomalies by surface geophysical investigations and subsequent confirmation borings appear to be concentrations of relatively small solution features within the limestone bedrock, and/or previously collapsed and clay-filled "paleo-sinkholes"; and

- Groundwater discharges at locations where the low-permeability layers outcrop at the surface, in the form of springs and seeps. The springs near Pitman Creek have been shown in previous investigations by dye trace studies to be connected to features upgradient of the CFI.

SECTION 5

ALTERNATIVES ASSESSMENT

5.1 Alternative Descriptions

This section summarizes the comparative alternatives assessment completed to select a long-term risk mitigation option based on consideration of a range of options for meeting the need to reduce risks at the Site. Four alternatives were developed based on the assessments:

- Alternative 1 - Monitor and Mitigate, including weekly dam inspections, clearing of woody vegetation and revegetation, periodic inspections, and limiting public access.
- Alternative 2 - CIP includes reduction/consolidation of the total area of CCB and construction of a new final cover system to essentially eliminate surface exposure and infiltration into the CCB. This would include the construction of stormwater basins north and south of Access Road No. 2. The impoundment for the south basin would be classified as a low hazard dam.
- Alternative 3 - Closure by Removal (CBR) includes removal of CCB, disposal in an expansion of the existing onsite CCR Landfill, and restoration of the CFI area, in general, to as close to preconstruction conditions as practicable. This would include the construction of a stormwater basin south of Access Road No. 2.
- Alternative 4 - *In Situ* Stabilization (ISS) includes construction of overlapping *in situ* stabilization (ISS) columns at the base of the CFI above karst locations as determined during detailed design based on the geophysical evaluations. This variation would be combined with Alternative 2, CIP with a new final cover system. This would include the construction of stormwater basins north and south of Access Road No. 2. The impoundment for the south basin would be classified as a low hazard dam.

5.2 Comparative Alternatives Assessment

A set of criteria was assessed to shed light on the pros and cons of the alternatives and how these four alternatives might impact the environment. The comparative alternatives assessment was conducted based on these criteria as follows:

5.2.1 Cost

Cost estimates were developed for each of the four alternatives based on preliminary design efforts. A conceptual design was developed for each alternative to calculate quantities of materials to be managed to be comparative at the time they were completed. Estimated costs include

preconstruction, construction, and long-term maintenance. Present worth values were not calculated. Table 5-1 summarizes the cost components calculated for each of the alternatives.

Table 5-1 Summary of Alternative Cost Estimates

Alternative	Estimated Capital Cost	Estimated Long-Term Maintenance Costs
Alternative 1 - Monitor and Mitigate	\$3,500,000	\$65,000 Annually
Alternative 2 - Closure In Place	\$47,200,000	\$65,000 Annually
Alternative 3 - Closure By Removal	\$113,600,000	\$0
Alternative 4 - Closure In Place with ISS	\$57,900,000	\$65,000 Annually

5.2.2 Environmental Impacts

Construction and long-term environmental impacts were evaluated for the proposed alternatives. Alternative 1 has a higher probability of a CCB release long-term through karst or surface contact because there is no cover in place. Alternative 3 has a higher probability of CCB release through karst features during construction due to the increased activity and excavation in proximity to underlying bedrock. Alternative 4 has a lower probability of release through karst than Alternative 2 due to the stabilization of the CCB over the karst areas through ISS. Releases through a dam/dike breach are unlikely based on slope stability analyses and visual observations.

Recent porewater and groundwater elevation data suggest that releases through karst features are unlikely given the separation (more than 30 feet) of groundwater from the bottom of the CFI. There is still a moderate potential during extreme rain events that water infiltrating through the CFI and into the subsurface below the CFI may mobilize material that may already be present in the karst and cause a release of CCB through groundwater to the tributary to Pitman Creek. ISS would further reduce but not eliminate this risk.

A high-level comparison of the potential environmental risks of each alternative is included in Table 5-2 and Table 5-3.

Table 5-2 Summary of Long-Term Environmental Risk Impact

Alternative	Overall	Dam/Dike Breach	Karst	Surface
Alternative 1 - Monitor and Mitigate	High	Low	Moderate	High
Alternative 2 - Closure In Place	Low	Low	Low	Low
Alternative 3 - Closure By Removal	Low	None	Low	None
Alternative 4 - Closure In Place with ISS	Low	Low	Low	Low

Table 5-3 Summary of Environmental Impact Risks During Construction

Alternative	Overall	Dam Breach	Karst	Surface
Alternative 1 – Monitor and Mitigate	Low	Low	Low	Low
Alternative 2 – Closure In Place	Moderate	Low	Moderate	Low
Alternative 3 – Closure By Removal	High	Low	High	Low
Alternative 4 – Closure In Place with ISS	Moderate	Low	Low to Moderate	Low

5.2.3 Constructability

The constructability criterion is used to evaluate potential adverse effects during construction, the ability to construct an alternative, the availability of materials, and the ability to maintain the facility. According to this criterion:

- Alternative 1 would require minimal construction for clearing, vegetation establishment, and long-term maintenance.
- Alternatives 2 would be completed with a much shorter construction duration than Alternative 3 and a shorter construction season than Alternative 4, reducing many construction-related safety risks. Consolidating the CCB footprint would require dewatering, but not on the scale of Alternative 3.
- Alternative 3 is considered challenging due to the nature of the construction process and the duration required to complete the construction. It is estimated that roughly 90,000 truckloads would be required to transport the CCB to the CCR Landfill. This extensive construction duration would increase the risks of onsite injuries and traffic related injuries. Additionally, dewatering would require pumping porewater at depths of almost 40 feet below the current ground surface.
- Alternative 4 is considered the most technically challenging and would be completed with a moderate construction duration. Alternative 4 would require the construction of a working platform to allow for access of heavy construction equipment and ISS. ISS is technically challenging with techniques not commonly applied and includes numerous assumptions on karst feature locations. Construction-related safety risks are higher than Alternative 2 and lower than Alternative 3. Consolidating the CCB footprint would require dewatering, but not on the scale of Alternative 3.

5.2.4 Schedules

Schedules to implement the alternatives were developed based upon the quantities of materials that must be handled and taking into consideration weather contingencies. To develop realistic and

comparable implementation schedules for each mitigation option, major critical path items associated with the implementation of each option were identified.

Alternatives 2 and 4 would require the same upfront design, permitting, and EKPC Board and Kentucky Public Service Commission (PSC) approvals. Alternative 3 would be similar but would not have a dam requirement for the south basin. Long-term activities for annual inspections and maintenance will include dam inspections for the stormwater basins proposed to meet the requirements for being a permitted dam with KDOW. A comparison of the construction schedules is included in Table 5-4.

Table 5-4 Alternative Schedules

Alternative	Construction Schedule (MO)
Alternative 1 - Monitor and Mitigate	4
Alternative 2 - Closure In Place	21
Alternative 3 - Closure By Removal	79
Alternative 4 - Closure In Place with In Situ Stabilization	21

5.2.5 Human Health & Safety

Safety concerns during implementation of the alternatives were addressed from a comparative perspective. For example, the alternative that takes the longest time and personnel effort could have a higher risk of an accident than an alternative that requires less effort and time to complete. This includes evaluation of alternative-specific tasks with increased safety concerns, such as dewatering to safely conduct grading or deep excavations within the disposal area.

Safety concerns were evaluated based upon short-term and long-term risks. Short-term risks were evaluated based upon site inspections and construction. Long-term risks were evaluated based upon post construction maintenance and monitoring. A summary comparison of the short-term safety risks is included in Table 5-5 and long-term safety risks are included in Table 5-6. The risks to Human Health & Safety are moderate for closure construction and are generally low for the long-term following closure. The risks for Alternative 1 long-term are moderate to high.

Table 5-5 Safety Short-Term Safety Risks

Alternative	Construction Duration	Surface Water Runoff	Fugitive Dust	Sinking of Equipment	Common Injuries	Traffic
Alternative 1 - Monitor and Mitigate	Shortest	Low	Low	Low	Moderate	Low
Alternative 2 - Closure In Place	Moderate	Low	Low	Moderate	Moderate	Moderate
Alternative 3 - Closure By Removal	Longest	Low	Moderate	High	High	High
Alternative 4 - Closure In Place with ISS	Moderate	Low	Low	Moderate	Moderate	High

Table 5-6 Safety Long-Term Safety Risks

Alternative	Groundwater	Surface Water	Surface Dust/Ingestion
Alternative 1 - Monitor and Mitigate	Low	Moderate	Moderate
Alternative 2 - Closure In Place	Low	Low	Low
Alternative 3 - Closure By Removal	Low	None	None
Alternative 4 - Closure In Place with ISS	Low	Low	Low

5.2.6 Potential Permitting Requirements Comparison

A detailed discussion of permitting requirements for the selected alternative is presented in Section 7 of this report. A comparison of permitting implications for the alternatives is discussed below.

- All of the alternatives may be impacted by the Endangered Species Act (ESA), the Migratory Bird Treaty Act (MBTA), and the National Historic Preservation Act.
- Alternative 3 includes a lateral expansion of the onsite CCR Landfill for the disposal of CCB. The Kentucky Division of Waste Management (KDWM) would require the Owner to meet the requirements of 401 KAR Chapters 45 and 46 (which implement the standards of the federal CCR Rule to obtain approval to operate and dispose of the CCB from the CFI within the waste boundaries of the previously approved Horizontal Expansion (APE2010001)).
- Alternatives 2, 3, and 4 would require modifications to the existing Kentucky Pollutant Discharge Elimination System (KPDES) permit.
- Alternatives 2, 3, and 4 would require coordination with the Kentucky Transportation Cabinet (KYTC) to utilize the existing outfall pipe system that extends under KY Route 1247.

- Alternatives 2 and 4 would require a Kentucky Division of Water Dam Construction Permit for the proposed southern stormwater basin.
- Alternatives 2 and 4 would require a Clay Mining Permit if the Owner purchases undisturbed property for the proposed borrow soil.

5.3 Comparative Assessment Summary

Geosyntec has reached the following initial conclusions concerning each alternative:

Alternative 1 - Monitor and Mitigate is the least costly but has the highest long-term risks, including the highest potential for future State or Federal regulation. Alternative 1 has the highest overall long-term risks because the CCB in the CFI would remain in place without a cover to inhibit the inflow of surface water into the CCB and underlying karst system.

Alternative 2 - CIP has a moderate cost and has the lowest short-term risks of the closure construction alternatives. Alternative 2 has slightly higher overall long-term risk than Alternative 4 because ISS further reduces the risk of infiltration at the location of identified karst features.

Alternative 3 - CBR is the most extensive, costly alternative, and poses the highest short-term risk for a release of CCR. However, Alternative 3 has essentially no long-term risks.

Alternative 4 - CIP with ISS has a significantly higher cost compared to Alternative 2. Alternative 4 has a slightly higher short-term risk due to additional construction work during the winter months and has a slightly lower long-term risk than Alternative 2.

5.4 Selected Alternative

EKPC selected Alternative 2 CIP as the preferred long-term risk mitigation option because it provides a reasonable option to close the CFI safely and effectively, leads to the least-cost long-term closure, has moderate to low short-term risks and long-term risk to the environment, construction schedule of less than two years, moderate implementation cost, and constructable concept.

SECTION 6

PROPOSED MITIGATION TO PROJECT RISKS

The long-term goals of this assessment would be achieved through the Closure in Place alternative by mitigating the risk of a dam breach, reducing surface exposure, reducing infiltration into the CCB, and limiting infiltration of CCB into karst areas.

- Human health & safety risks during construction, such as exposure, submergence, common injuries, traffic accidents, etc., would be mitigated through the use of industry standard safety mechanisms during construction. The Contractor will be responsible for developing and adhering to a project specific health and safety plan.
- There is an increased risk of CCB release through the following mechanisms during construction:
 - Surface - There could be a high risk of surface exposure caused by wind generated dust and airborne CCB during construction. However, this risk will be mitigated by a dust suppression plan and limiting the cleared CCB surface to active work areas.
 - Dam breach - The results of the geotechnical investigation and the stability analyses for the CIP loading conditions indicate a very low risk of dam breach.
 - Karst - There would be a moderate risk of erosion of CCB and soils over the underlying karst during construction and there would be a higher risk that CCB that is already in the karst could be mobilized. This will be managed during excavation through best management practices to control stormwater run on/runoff and installation of stormwater controls at the beginning of the construction.
- The use of the KYTC stormwater piping would require encroachment permitting from KYTC and is currently considered a construction risk. An additional risk for utilization of the KYTC KY Route 1247 48-inch diameter stormwater piping is that KYTC may not agree with the design and stormwater modeling approach, requiring changes in basins, etc., to meet the encroachment requirements, thereby increasing costs and lengthening the implementation schedule.

SECTION 7

PERMITTING ASSESSMENT

This section summarizes certain technical considerations relevant to permits and approvals that may be required to implement CIP. A permit matrix is included in **Appendix B**.

- Section 404 of the Clean Water Act (CWA) – Based on a recent site reconnaissance, the presence of jurisdictional streams or wetlands on the Site is considered unlikely.
- Endangered Species Act (ESA) – An on-line search identified species that may be potentially affected by activities at the site. Coordination with the U.S. Fish and Wildlife Service would be required if the project may affect such species, and formal Section 7 consultation under the ESA may be required if any federal agency approvals or financing are required.
- The Migratory Bird Treaty Act (MBTA) – Nesting birds may be present on site if work is completed during the nesting season (April 1 to July 31). If nesting birds are present onsite, coordination with the USFWS would be required before any clearing could occur during the nesting season.
- KPDES – During closure activities, two new permanent outfalls will be necessary for discharges of stormwater from the CFI area. These new outfalls would need to be added as modifications to the existing KPDES permit. Furthermore, construction stormwater discharges, including discharges from any dewatering activities, would require notice to the Kentucky Division of Water (“KDOW”) and may require a modification to the KPDES permit.
- Historic Preservation – NHPA Section 106 consultation with the State Historic Preservation Officer may be required if closure requires a federal approval or financing and may affect historic properties listed on or eligible for listing on the National Register of Historic Places.
- KYTC – Coordination with KYTC is anticipated to utilize the existing outfall pipe system. The 48-inch diameter CMP located at the southeast corner of KY Route 1247 and Access Road No. 2 connects to MH-4 and discharges at the outfall pipe system headwall downstream.
- Kentucky Division of Water Dam Construction Permit – The proposed southern stormwater basin is anticipated to be classified as a dam per Kentucky Revised Statute (KRS) 151.100 due to its storage volume. Therefore, dam regulatory design requirements promulgated in 401 KAR 4:030 (*Engineering Memorandum No. 5*) (Department for

Natural Resources and Environmental Protection Division of Water, 1999) would be adhered to in its design. It is anticipated the new dam will be considered a Class A Dam (i.e., low hazard potential classification) per definitions provided in Section B of 401 KAR 4:030. Implications include completing a detailed dam design, an emergency action plan, permit applications with KDOW, and ongoing maintenance and inspection requirements in accordance with the KDOW dam safety program requirements.

SECTION 8

DESIGN DOCUMENTS

This section describes the content of the CIP 90 percent design that has been prepared following the process to select the preferred alternative.

8.1 Closure Design Description

The CIP design includes reduction of the total area of CCB through consolidation, construction of a new final cover system to minimize surface exposure and infiltration into the CCB, and construction of new run on/off controls. The reduction of the “footprint” of the CFI would be accomplished by excavation of CCB from the margins of the CFI and consolidating the CCB within a smaller footprint. After the CCB footprint is reduced, site grading of the new fill area would occur to allow surface water to drain from the final cover system to new ditches and stormwater basins.

Surface water would run off the new cover system to new ditches at the perimeter and drain to culverts through the dam that lead to the new stormwater basins. The stormwater basins would drain into current surface water drainage pipes below KY Route 1247.

The new final cover system would be designed and constructed to meet the technical requirements of the CCR Rule, even though the CFI is not a regulated CCR unit under the CCR Rule.

8.1.1 Stormwater Management

Along the northern and southern perimeters of the CFI, new lined ditches would be installed to convey surface water east to west to box culverts through the former dam. The culverts would drain to new stormwater basins on the north and south side of Access Road No. 2 which will discharge to the existing 48-inch culvert below KYTC Route No. 1247.

The southern stormwater basin would impound more than 50 acre-ft during the 100-year storm event and therefore would be classified as a low hazard potential dam by the KDOW. New KPDES permitted outfalls will be required prior to construction.

The current design includes a temporary perimeter stormwater collection system to reduce the amount of run-on to the CFI area during construction. This stormwater system includes the construction of temporary containment berms at select locations to allow for pumping of non-contact stormwater to the north stormwater basin which will discharge through a new KPDES permitted outfall. The north stormwater basin will only receive non-contact stormwater. Small

diversion berms will be constructed to direct non-contact stormwater to the containment berm areas.

The current design also includes the south stormwater basin to act as a temporary sedimentation basin for contact stormwater, which would be temporarily lined with 40 LLPDE and a temporary riser pipe constructed to allow for settling of total suspended solids (TSS). The temporary lining and riser will be removed following construction. The precipitation that falls within the perimeter stormwater collection system would be considered contact stormwater and pumped to the south stormwater basin. Following settling, the stormwater will then discharge through a new KDPES permitted outfall. Contact stormwater shall only be pumped to the south stormwater basin during and directly following storm events. Waters collected via CCB dewatering activities are not to be pumped to the south stormwater basin without prior treatment.

8.1.2 Dewatering

CCB will be dewatered as necessary to facilitate construction. Dewatering will consist of excavating ditches and constructing sumps at select locations where the planned excavation will be within five feet of the porewater. Porewater will be pumped and discharged to a treatment system to be determined prior to being discharged through a proposed KPDES permitted outfall downstream of KY Route 1247.

No discharge from dewatering activities will be directed off-site without controls to meet the renewed KDPES permit requirements. Secondary containment will be used as necessary during dewatering.

8.1.3 Cover System

The two-foot-thick cover system would be comprised of a geomembrane installed on the top surface of the CCB, then geotextile cushion will be placed on top of the geomembrane, followed by a protective layer. Soil capable of supporting vegetation would be included as the final six inches of the protective cover. Topsoil would be vegetated with native grasses to preclude erosion of the cover system. Native grasses would be selected that have shallow root systems that would not penetrate all the way through the protective layer. The cover system grades would allow surface water in the reduced footprint of the CFI to drain towards the northern and southern perimeters of the CFI with a proposed grade drop of two percent from the center of the CFI to the north and south, in both directions, respectively.

8.2 Geotechnical Considerations

8.2.1 Slope Stability

Slope stability analyses of the former dam, the proposed south stormwater basin dam, proposed north basin embankment, Access Road No. 2 embankment, the proposed 4H:1V slopes along the CFI, and the eastern dike (near C-26) were performed under the proposed final conditions. Temporary culvert excavation slopes were also evaluated as the excavations were greater than 20 ft deep and require a design, that meets OSHA guidelines (Occupational Safety and Health Administration (OSHA), 2020). Veneer stability analyses were also performed under similar criteria to global stability to evaluate stability along the cover soil, geotextile, geomembrane, and subgrade interfaces.

The selected criteria for global slope stability were adopted from industry standards and include the target Factors of Safety (FoS) consistent with USACE engineering and design criteria (US Army Corps of Engineers, 2013).

Results of the slope stability analyses indicate that the former dam, eastern dike, Access Road No. 2, proposed embankments and veneer stability are above the target FoS values. These embankments are expected to be stable under the loading conditions considered in this evaluation.

8.2.2 Settlement

A cover system settlement analysis was conducted to ensure that the integrity of the final cover system is not compromised by differential settlement and that post-settlement grades are sufficient for effective long-term stormwater management. Post-settlement drainage slopes on the final cover system remain positive and no ponding on the cover is expected.

8.3 Hydraulic and Hydrologic Considerations

8.3.1 Perimeter Stormwater System

Hydrologic calculations were performed to size a perimeter stormwater collection system to reduce the amount of run-on to the construction area. These features were sized to adequately intercept, contain and convey watershed surface runoff from a 2-year, 24-hour storm event.

8.3.2 Contact Stormwater

Hydrologic calculations were performed to confirm the south stormwater basin could contain a 2-year, 24-hour storm event for the stormwater that falls within the perimeter stormwater collection system and have sufficient surface area to allow for settling of total suspended solids (TSS). A turbidity curtain would surround the temporary riser pipe.

8.3.3 Post-Closure Stormwater Management

Hydrologic calculations were performed to size stormwater management features associated with closure activities. These features were sized to adequately contain, convey, and attenuate design storm events (25-year/24-hour, 100-year/24-hour duration, and freeboard hydrograph [FBH] rainfall events) as to avoid ponding on the closure cap system and mitigate impacts to downstream infrastructure.

The stormwater management system layout consists of armored and lined perimeter ditches, culverts through the dam, and stormwater basins fitted with conduit spillways. The stormwater basins are designed to remain dry between rainfall events (i.e., fully drain attenuated storm runoff so there would not be residual retention or ponding in the basin). The two stormwater basins (lined with one foot of clay) located downstream of the perimeter ditches would serve to store and attenuate stormwater runoff volume and peak discharge rate.

The two stormwater basins would have a combined storage volume that would require the south to be classified as a dam per Kentucky KRS Chapter 151.100 (classified as dam if 50 acre-feet or more of storage volume). Therefore, additional dam design requirements for the southern stormwater basin have been accounted for in the design (including additional spillway design requirements) per Engineering Memorandum No. 5 (Department for Natural Resources and Environmental Protection Division of Water, 1999).

Box culverts would extend through the former dam to convey stormwater runoff from the two perimeter ditches to the two downstream stormwater basins. Discharge from the northern downstream stormwater basin would flow through a new 18-inch diameter CMP principal spillway that connects to the existing 36-inch diameter CMP culvert through the Access Road No. 2 embankment. Discharge would flow towards the existing 48-inch diameter CMP culvert through KY Route 1247 to the headwall downstream and ultimately to the Pitman Creek tributary.

Riprap chutes and aprons would withstand velocities and shear forces from the 100-year/24-hour design event discharge from the culverts and spillways. The riprap aprons would serve to dissipate energy from the storm discharge prior to flowing downstream. The southern stormwater basin emergency spillway riprap lining and apron would withstand and dissipate energy from the FBH design event discharge (greater than the 100-year/24-hour discharge).

8.4 Design Drawings

The following drawings were developed based on the parameters discussed in this section and are included in in **Appendix C.**:

- Cover (1 sheet)
- Existing Conditions (1 sheet)
- Demolition and Clearing (1 sheet)
- Dewatering Plan (1 sheet)
- Perimeter Stormwater Control System (2 sheets)
- Box Culvert Plans, Sections and Details (1 sheet)
- Stormwater Basin Plans, Sections and Details (2 sheet)
- Excavation Plan (1 sheet)
- Subgrade Plan (1 sheet)
- Final Cover Grades Plan (1 sheet)
- Profile and cross sections (1 sheet)
- Perimeter Ditch Profiles (1 sheet)
- Final Cover Details (depicting the cover, edge of cover details, drainage ditching, and dewatering) (2 sheets)
- Erosion and Sediment Control (location of temporary and permanent stormwater management features) (2 sheet)

8.5 Project Schedule

The estimated total construction schedule duration for Alternative 2 is 21 months as noted in **Appendix D.** The construction schedule to implement closure was developed based upon the quantities of materials that must be handled and taking into consideration weather contingencies with major critical path items identified. The production rates of borrow material transported on-site and the regrading of CCB within the CFI are critical factors. Due to the relatively low elevation of the existing phreatic surface, no preconstruction dewatering duration was assumed.

Long-term activities for annual inspections and maintenance are anticipated to include dam inspections for the stormwater basins proposed to meet the requirements for being a permitted dam with KDOW.

8.6 Construction and O&M Cost Estimate

The estimated construction cost for Closure In Place is \$47,200,000 with a 15 percent contingency and accounting for inflation (federalreserve.gov) as detailed in **Appendix E**. The estimated construction cost increased from the alternatives analysis to the 90 percent design because of the recent changes in the market, the addition of inflation, and design related modifications. A discussion of select cost items is included below:

- Borrow soil and riprap material costs have a significant impact on the project costs and therefore a local Contractor's input was considered. The borrow was utilized as the soil for the protective layer of the cap, the liner of the stormwater basins, the stormwater basin berms, and the temporary upstream stormwater berms. The riprap will be utilized in the perimeter ditches, spillways, and outfall aprons.
- Dewatering was assumed to be conducted during the ongoing excavation of the CCB dewatering ditches through the completion of the cover system. The treatment of dewatering water is based on water treatment completed for similar applications at other EKPC facilities. The final design will be based on the Cooper Station KPDES permit requirements.
- Long-term costs include annual inspections, mowing, and routine maintenance; the estimated cost is assumed to be on the order of \$65,000. This includes quarterly inspections, cover maintenance, vegetation maintenance, mowing, and stormwater maintenance.

8.7 Construction Project Cash Flow

The estimated monthly project cash flow is based on the project capital and O&M cost estimate applied to the proposed construction schedule. **Appendix E** includes the cumulative and monthly project cash flow figures.

8.8 Construction Methods

The primary concerns with constructability of the CFI closure are stormwater control, dewatering, and potential soft ground conditions during construction as discussed in Section 5.2.3. Dewatering would reduce the risk of construction safety during soft ground conditions and increase the Contractor's effectiveness due to consolidating select areas of the CFI. This alternative would require long-term maintenance, but it is anticipated to be primarily mowing and minor repairs.

8.9 Summary

A CIP approach meets EKPC's project goals of environmental protection and provides the least cost reasonable alternative. The conceptual design provides a reasonable option to close the CFI safely and effectively and leads to the least-cost reasonable alternative.

SECTION 9

REFERENCES

- Department for Natural Resources and Environmental Protection Division of Water. (1999). *Engineering Memorandum No. 5*.
- Kentucky Division of Water. (1995). *Inspection of East Kentucky Power Ash Storage Dam No. 2 KY0793*.
- Kentucky Geological Survey. (1997). *Hydrogeology and Ground-Water Monitoring of Coal-Ash Disposal Sites in a Karst Terrane near Burnside, South-Central Kentucky*.
- Occupational Safety and Health Administration (OSHA). (2020). *Safety and Health Regulations for Construction 1926 Subpart P - Excavations*. Washington D.C.
- US Army Corps of Engineers. (2013). *EM 1110-2-1902 Slope Stability*.
- US Army Engineer District, Louisville Corps of Engineers. (March 1979). *East Kentuck Power: Ash Storage Dam*.
- USEPA. (2015). *40 CFR Parts 257 and 261. Hazardous and Solid Waste Management System; Disposal of Coal Combustion Residuals from Electric Utilities; Final Rule*.

APPENDIX A CONCEPTUAL SITE MODEL

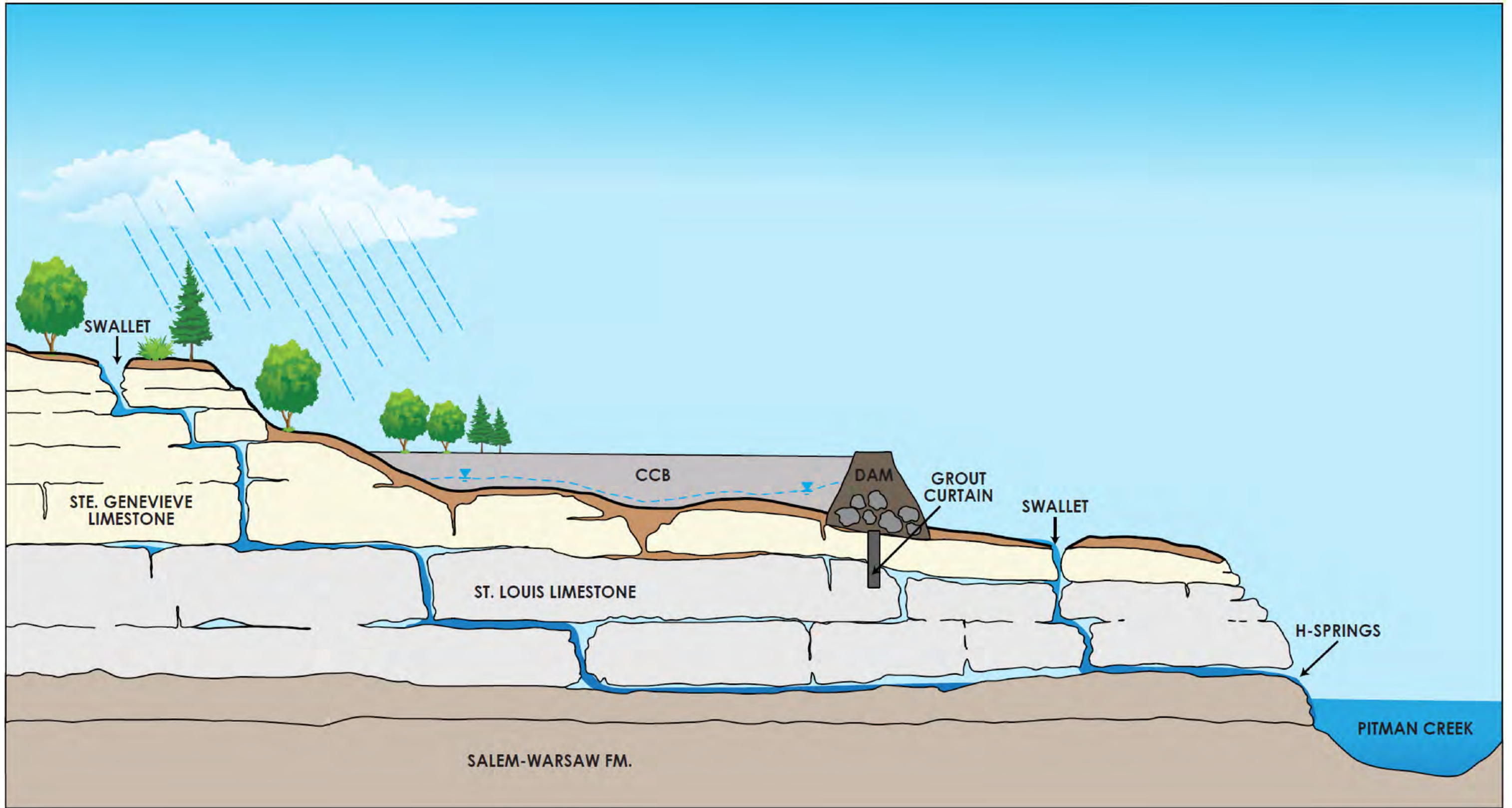

ARO-01\VA-ro-01\prj1\E\East Kentucky Power\Cooper Legacy Pond\GIS\New folder\Appendix A - CSM Cartoon.mxd 3/25/2022 4:48:40 PM

Conceptual Sketch - Not to Scale
 This drawing presents important features of the conceptual site model and is not intended to be a comprehensive representation of the complex hydrogeologic conditions at the Site.

CONCEPTUAL SITE MODEL East Kentucky Power Cooperative Cooper Former Impoundment		
 EAST KENTUCKY POWER COOPERATIVE <small>A Touchstone Energy Cooperative</small>	 Geosyntec consultants	APP. A
Kennesaw, Georgia	March 2022	

APPENDIX B PERMIT MATRIX

Facility: Cooper Former Impoundment
Client: EKPC
Project: Project Scoping Report
Project No.: GLP8015
Date: June 14, 2023

Permit Requirement Matrix										
Federal	Description	Agency	Permit Duration	Permit Holder	Permit Application Development Duration	Approximate Agency Review	Applicable (Y/N)	Permit Considerations and Issues		
a.	Endangered Species Act (ESA) of 1973	USFWS	The ESA is the primary law to conserve and protect threatened and endangered (T&E) species and their habitats. If a federal agency approval is required for a project (such as a CWA Section 404 permit), that agency must evaluate whether its action will affect T&E species and consult with the U.S. Fish and Wildlife Service pursuant to Section 7 of the ESA if the action "may affect" such species. If no federal agency approval is required, a private party still must ensure that its action will not "take" a T&E species in violation of Section 9 of the ESA. In the likely absence of a CWA Section 404 permit requirement for this project, Section 7 consultation involving USACE appears unlikely. Moreover, even if no federal action is required, obviating the need for Section 7 consultation, EKPC would nevertheless need to coordinate with USFWS to ensure that any activities such as tree cutting will not adversely affect T&E species such as endangered bats and may be required to pay to mitigate such effects.	USFWS	USFWS Informal or Section 7 Consultation would not have expiration date, provided there are not changes in status or newly listed species. Payment of any mitigation fees will be required before any actions are taken that may affect T&E species.	EKPC	If applicable, 3 months to develop a Biological Assessment letter and surveys for sensitive species (seasonal).	90 days	Y	Any tree cutting, etc., will require coordination with USFWS (either Section 7 or Section 9). Section 7 consultation could result in schedule impact of 6 months. Payment of mitigation fees would result in minimal delay (1-2 months).
b.	The Migratory Bird Treaty Act of 1918 (16 U.S.C. 703-712, MBTA)	USFWS	The MBTA prohibits the taking (including killing, capturing, selling, trading, and transport) of protected migratory bird species without prior authorization by the USFWS. Nesting birds may be present on site if work is completed during the nesting season (April 1 to July 31). Removing trees during nesting season would require additional studies to determine if protected migratory bird species are present onsite.	USFWS	Because the USFWS only issues permits to authorize individuals or organizations to take or possess birds for certain activities and purposes, any take outside of the permitted activities is prohibited. No permit will be issued for the project; steps must be taken to ensure no migratory bird take.	--	--	--	Y	If migratory birds may be present, would require coordination with USFWS if clearing occurs between April 1 to July 31.
c.	National Environmental Policy Act (42 U.S.C. 4321)	Any federal agency providing authorization or financial assistance	NEPA requires any federal agency providing an authorization or financial assistance to a project to evaluate the potential direct, indirect and cumulative effects of that action on the environment. Depending on the magnitude of the action and expected effect, compliance can be accomplished through a preparation of a Categorical Exclusion, Environmental Assessment or Environmental Impact Statement.	Any federal agency providing authorization or financial assistance	NEPA compliance is a one-time requirement that must be completed before federal support or approval is provided.	--	If applicable: Categorical Exclusion: One month Environmental Assessment: 3 months Environmental Impact Statement: Two years +	If applicable: Categorical Exclusion: Two months Environmental Assessment: Six months to one year Environmental Impact Statement: Two years +	N	If no CWA Section 404 permit is required, no NEPA compliance by COE required.
State and Local	Description	Agency	Permit Duration	Permit Holder	Permit Application Development Duration	Approximate Agency Review	Applicable (Y/N)	Permit Considerations and Issues		
a.	Existing KPDES Permit Modification	KDOW	If closure in place will create a new source or discharge of industrial wastewater or stormwater, the existing KPDES permit for the Cooper Station would need to be modified to identify any new waste stream and the outfall for the new source.	KDOW	Ongoing.	EKPC	90 days pending KDOW review	May take up to two (2) years from submittal of application	Y	EKPC revised the KPDES permit with additional outfalls for this project.
b.	Kentucky Pollution Discharge Elimination System (KPDES) Permit BMPP Modification	KDOW	Construction activity conducted at or on properties that have obtained an individual or general KPDES permit for the discharge of other wastewaters requires the development of a Best Management Plan (BMP). The Cooper Station operates under KPDES Permit No. KY000361, which will require a revised BMP to cover this activity.	KDOW	--	EKPC	The permittee will modify the BMP whenever there is a change in the facility or change in the operation. This must be completed prior to the work taking place. A Stormwater Pollution Prevention Plan (SWPPP) may be developed and an NOI submitted to supplement the BMP if KDOW requires it. This would take approximately 30 days.	No agency review necessary on BMP update.	Y	Modify BMPP to include best management practices for Closure in place process and supplement with SWPPP if needed.
c.	Kentucky Dam Permitting Regulations, 401 KAR 4:030, 4:060	KDOW	Construction or modification of a dam requires a permit from KDOW. A dam is defined as any structure that impounds water and is either at least 25 feet in height from the downstream toe of the impounding structure or that has the capacity to impound 50 acre-feet or greater. Regulated structures include dams impounding sedimentation or stormwater control basins if they meet the minimum criteria, as well as structures that do not meet the minimum criteria but that pose a threat of significant property damage or threaten human life in the downstream area. A construction permit from KDOW is required to commence construction, and approval of as-built plans by KDOW is required before impounding water. See 401 KAR 4:030 for technical requirements.	KDOW	Construction permit duration is one (1) year from issuance, subject to successive renewals if needed. No "ongoing" permit but KDOW inspects and regulates existing dams and may order remedial work if needed.	EKPC	Relies on KDOW Application for Permit to Construct Across or Along a Stream Public notice to be run and proof included with permit application Application development - 3 to 6 months	20 working days	Y	Dam construction permit likely required for proposed stormwater control pond.
d.	Construction/Demolition Debris (CD&D) Landfill Permit, KRS Chapter 224 and 401 KAR Chapters 30, 40, 47, and 48 [KRS 224.40-305]	KDWM	Relocate the existing Construction/Demolition Debris (CD&D) Landfill currently within the CFI. This will require permitting a new CDD Landfill.	KDWM	Ongoing.	EKPC	12 months to develop the permit, complete the NOI, public notice and agency reviews	30 calendar days for NOI review 60 working days for application review 30 day public notice 90 working days for technical application	Y	Permit required for relocating the CD&D Landfill.
e.	Historic Preservation	Kentucky Heritage Council (KHC) (SHPO)	Section 106 of the National Historic Preservation Act (NHPA) requires federal agencies or their applicants to take into account the effects of their undertakings on historic aboveground and archaeological properties. Section 106 only applies if the proposed action requires a federal approval (such as a CWA Section 404 permit). Because EKPC and its Consultant have concluded that jurisdictional waters of the U.S. are not present, a CWA Section 404 permit is likely not required. Nor are any other federal permits likely. If a USACE permit were required, the Corps would be required to coordinate with the KY State Historic Preservation Officer (SHPO).	Kentucky Heritage Council (KHC) (SHPO)	If applicable, KHC performs a Site Check to determine if historical or cultural resources will be impacted. No permit is issued. Agency, KHC and applicant must address potential adverse effects before action may proceed.	--	Section 106 Review and Compliance Cover Sheet and Site Check application - 5 days	With complete application - 30 days	Unlikely	Will require coordination with KHC if federal approval such as Section 404 permit is required. This will include a schedule impact of approximately 35 days. This is considered unlikely.
f.	Clay Mining for Borrow Site	KEEC	The Kentucky Energy and Environment Cabinet requires a permit for non-coal mining activities that disturb soil and haul material off site. The permit application requires detailed information about the site, surrounding property, reclamation plans, and storm water planning. The permit application must be sealed by a PE in the state of Kentucky. A public meeting and advertisement must also be provided unless EKPC purchases soil from a local supplier.	KEEC	The permit is good for five years.	EKPC	6 months to develop the permit application, bond approvals, advertisements, public hearings, historical review, surface water quality plan, backfilling plan, equipment list	30 day review period but the agency is currently running behind on reviews	Unlikely	This is only required if EKPC purchases and provides property for this work. 6 months of preconstruction schedule time for developing the advertisement, public comment period, and public hearings in addition to the time required to purchase the property. 30 day review period.
g.	KYTC (Utilizing Their Culvert for Drainage)	KYTC	This will require an Encroachment permit and a bond permit with KY Transportation Cabinet. They can be \$100k or more. Review time can be 30 days if no other permits to review with the cabinet.	KYTC	One time permit request	EKPC	1-2 months depending on bond timing	30 review period	Y	1-2 month prep based on stormwater design and 30 day review by KYTC

APPENDIX C DESIGN DRAWINGS

EAST KENTUCKY POWER COOPERATIVE COOPER FORMER IMPOUNDMENT CLOSURE DESIGN

COOPER POWER STATION, SOMERSET, KENTUCKY PROJECT NO. GLP8015 MAY 2023



SOURCE: BING MAPS
VICINITY MAP
SCALE IN MILES



SOURCE: BING MAPS
LOCATION MAP
SCALE IN FEET

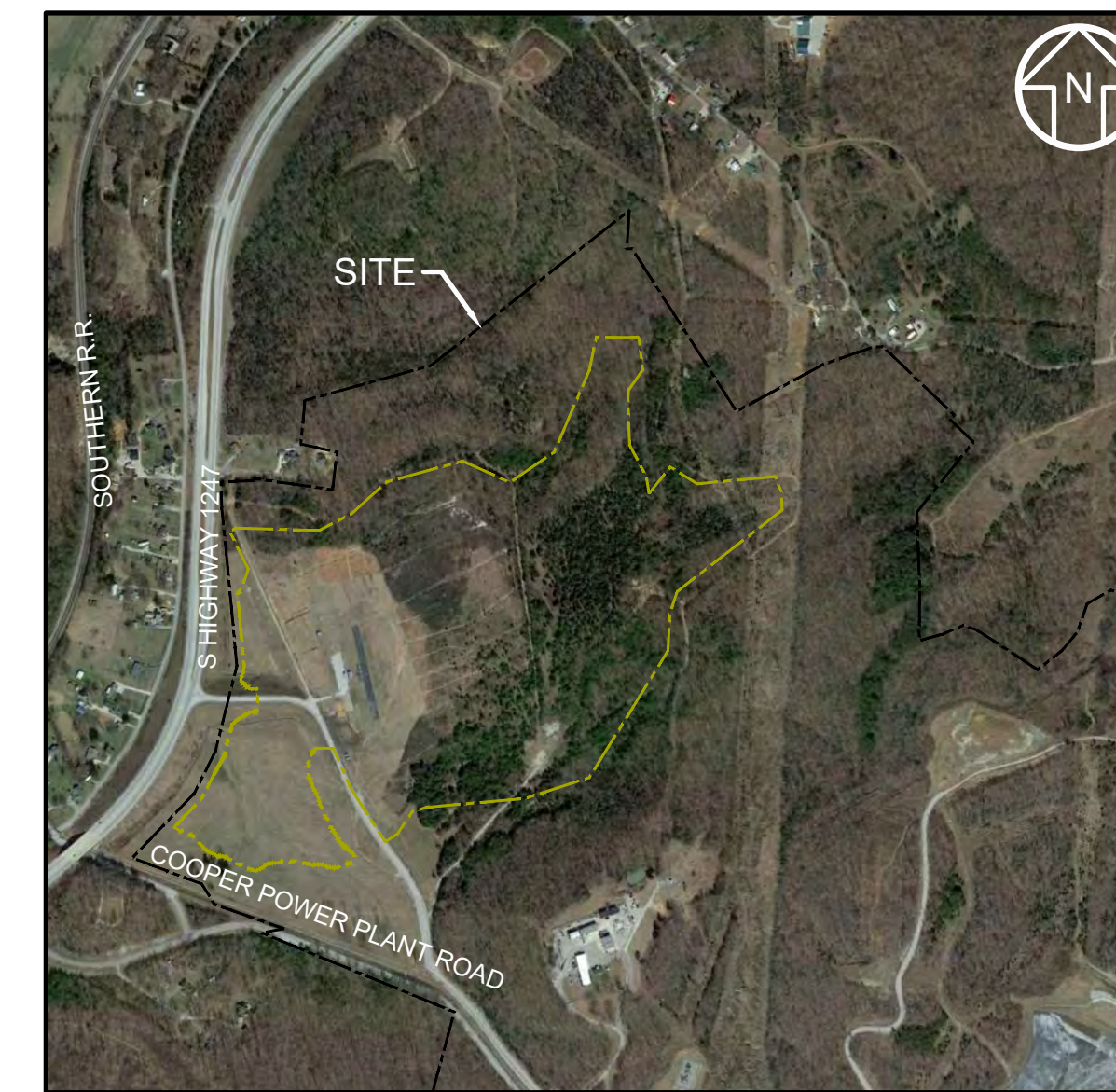

SOURCE: BING MAPS
SITE MAP
SCALE IN FEET

LIST OF DRAWINGS	
SHEET NO.	DRAWING TITLE
1	COVER SHEET
2	EXISTING CONDITIONS
3	DEMOLITION AND CLEARING
4	CONCEPTUAL DEWATERING PLAN
5	TEMPORARY PERIMETER STORMWATER CONTROL SYSTEM PLAN VIEW
6	PERIMETER STORMWATER CONTROL SYSTEM PROFILES
7	BOX CULVERTS PLAN VIEW, SECTIONS AND DETAIL
8	SOUTH STORMWATER BASIN DESIGN PLAN VIEW, SECTIONS AND DETAILS
9	NORTH STORMWATER BASIN DESIGN PLAN VIEW, SECTIONS AND DETAILS
10	EXCAVATION PLAN
11	GEOMEMBRANE SUBGRADE PLAN
12	FINAL COVER GRADING PLAN
13	PROFILES AND SECTIONS
14	NORTH AND SOUTH DITCH PROFILES
15	DETAILS 1 OF 2
16	DETAILS 2 OF 2
17	TEMPORARY EROSION AND SEDIMENT CONTROL
18	PERMANENT EROSION AND SEDIMENT CONTROL

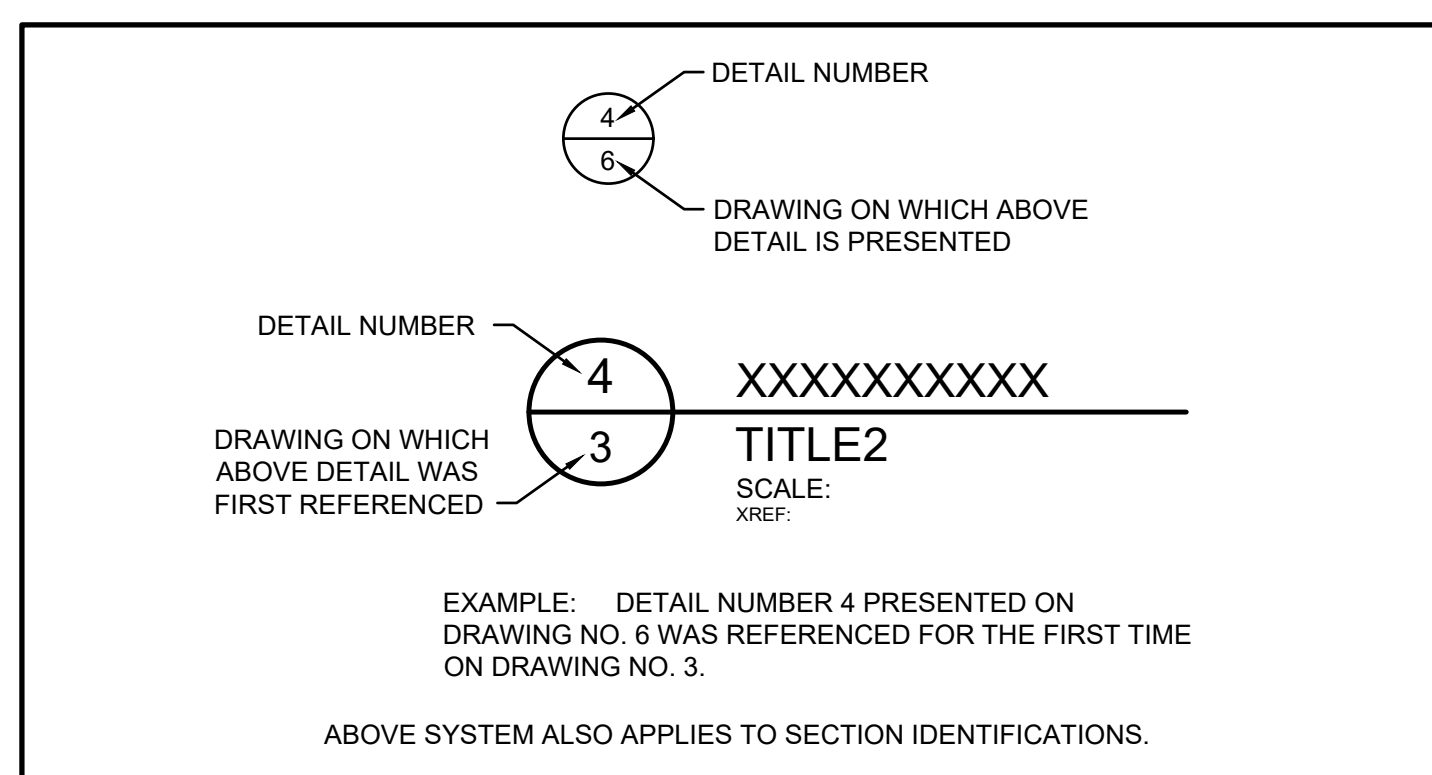

DETAIL IDENTIFICATION LEGEND

PREPARED FOR:



PREPARED BY:



1 MCBRIDE AND SON CENTER DRIVE, # 202
CHESTERFIELD, MISSOURI 63005
TELEPHONE: 636-812-0800

90% DESIGN DRAWINGS - NOT FOR CONSTRUCTION

REV	DATE	DESCRIPTION	DRN	APP
TITLE: COVER SHEET				
PROJECT: EAST KENTUCKY POWER COOPERATIVE COOPER FORMER IMPOUNDMENT CLOSURE DESIGN				
SITE: COOPER POWER STATION, SOMERSET, KENTUCKY				
DESIGN BY:	ZJF	DATE:	MAY 2023	
DRAWN BY:	MGK	PROJECT NO.:	GPL8015	
CHECKED BY:	TWW	FILE:		
REVIEWED BY:	TWW	DRAWING NO.:	1 OF 18	
APPROVED BY:	JPS			

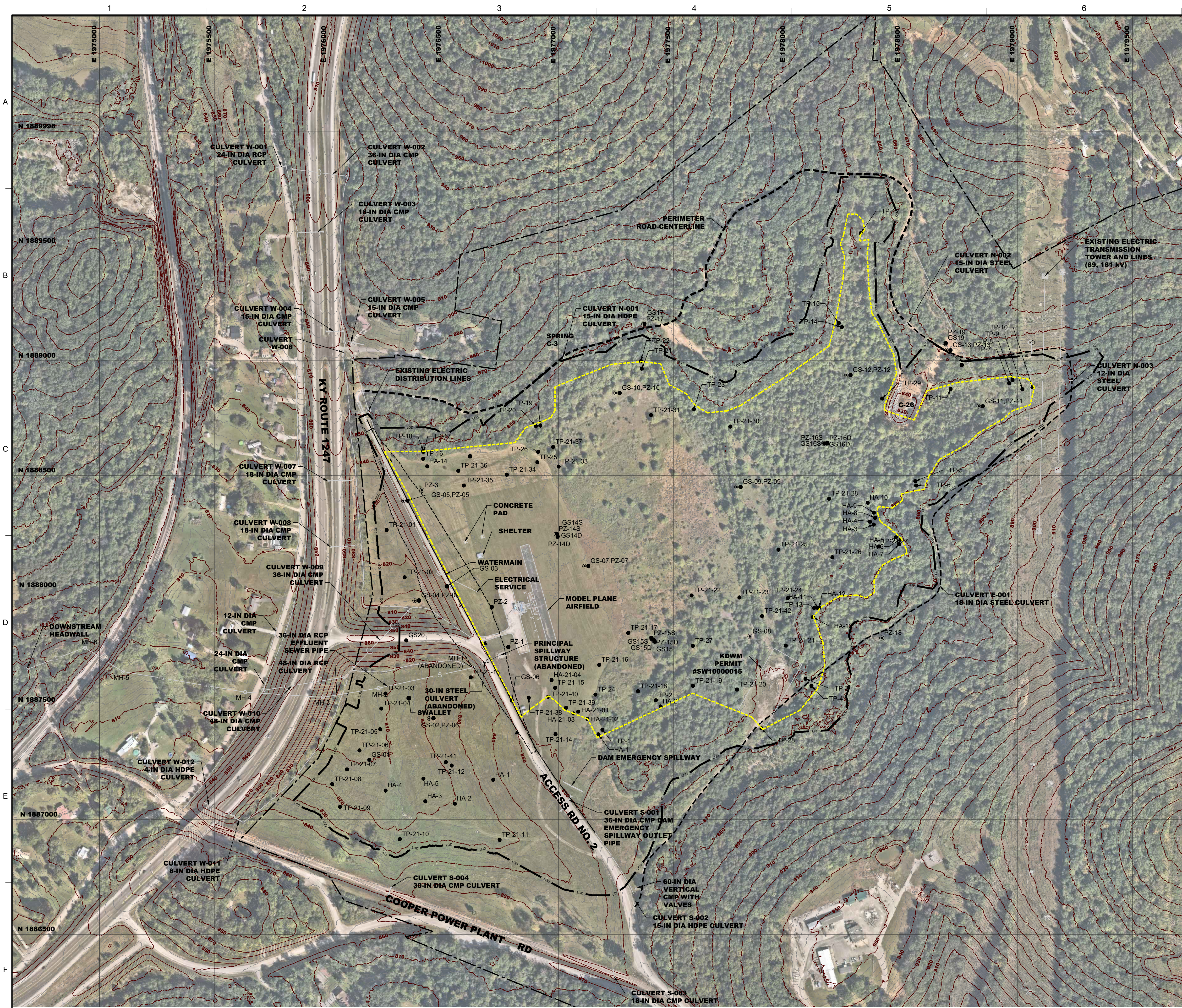

LEGEND

- PROPERTY BOUNDARY
- LIMITS OF CCB
- EXISTING PERIMETER ROAD - CENTERLINE
- PRECONSTRUCTION GROUND SURFACE ELEVATION (2- FT INTERVAL)
- PRECONSTRUCTION GROUND SURFACE ELEVATION (10- FT INTERVAL)
- EXISTING OVERHEAD ELECTRIC LINE
- EXISTING DITCH
- EXISTING CHAIN LINK FENCE
- EXISTING CULVERT
- EXISTING 48" DIA EFFLUENT SEWER LINE
- ABANDONED EXISTING 48" DIA EFFLUENT SEWER LINE
- LOD
- EXISTING ELECTRIC POLE
- EXISTING ELECTRIC TRANSMISSION TOWER
- EXISTING LIGHT POLE
- TP-29 EXPLORATION TEST PIT, BORING, OR HAND AUGER PROBE LOCATION
- PZ-13 PIEZOMETER LOCATION

TABLE 1

CULVERT INFORMATION TABLE

ID	UPSTREAM INVERT	DOWNSTREAM INVERT	DESCRIPTION
N-001	851.1	850.7	HDPE 15-IN DIA
N-002	852.6	850.6	STEEL 15-IN DIA
N-003	-	847.9	STEEL 12-IN DIA
E-001	860.2	861.0	STEEL 18-IN DIA
S-001	844.4	842.2	CMP 36-IN DIA
S-002	863.0	863.0	HDPE 15-IN DIA
S-003	856.7	854.2	CMP 18-IN DIA
S-004	844.00	844.2	CMP 30-IN DIA
W-001	863.8	860.8	RCP 24-IN DIA
W-002	887.7	865.8	CMP 36-IN DIA
W-003	880.5	893.0	CMP 18-IN DIA
W-004	876.8	876.2	CMP 15-IN DIA
W-005	-	-	CMP 15-IN DIA
W-006	875.7	874.9	CMP 22-IN DIA
W-007	-	835.6	CMP 18-IN DIA
W-008	-	827.5	CMP 18-IN DIA
W-009	804.4	803.4	CMP 36-IN DIA
W-010	797.8	802.9	CMP 48-IN DIA
W-011	-	841.9	HDPE 8-IN DIA
W-012	860.1	859.5	HDPE 4-IN DIA

NOTE:
1. LOCATION OF WATER MAIN TO BE FIELD VERIFIED BY THE CONTRACTOR.

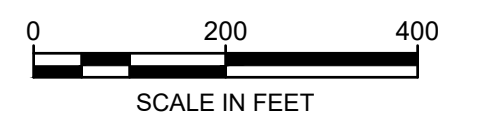

REV	DATE	DESCRIPTION	DRN	APP

1 MCBRIDE AND SON CENTER DRIVE, # 202
CHESTERFIELD, MISSOURI 63005
TELEPHONE: 636-812-0800

4775 LEXINGTON RD., PO BOX 707
WINCHESTER, KY 40392

TITLE: EXISTING CONDITIONS

PROJECT: EAST KENTUCKY POWER COOPERATIVE COOPER FORMER IMPOUNDMENT CLOSURE DESIGN

SITE: COOPER POWER STATION, SOMERSET, KENTUCKY

DESIGN BY:	ZJF	DATE:	MAY 2023
DRAWN BY:	TMM	PROJECT NO.:	GPL8015
CHECKED BY:	TWW	FILE:	
REVIEWED BY:	TWW	DRAWING NO.:	2 OF 18
APPROVED BY:	JPS		

90% DESIGN DRAWINGS - NOT FOR CONSTRUCTION

P:\KIP\1515\BAPIC\COOPER\LEGACY\CONTRACTOR\WORKING\DRAWINGS\15151502\EXISTING CONDITIONS

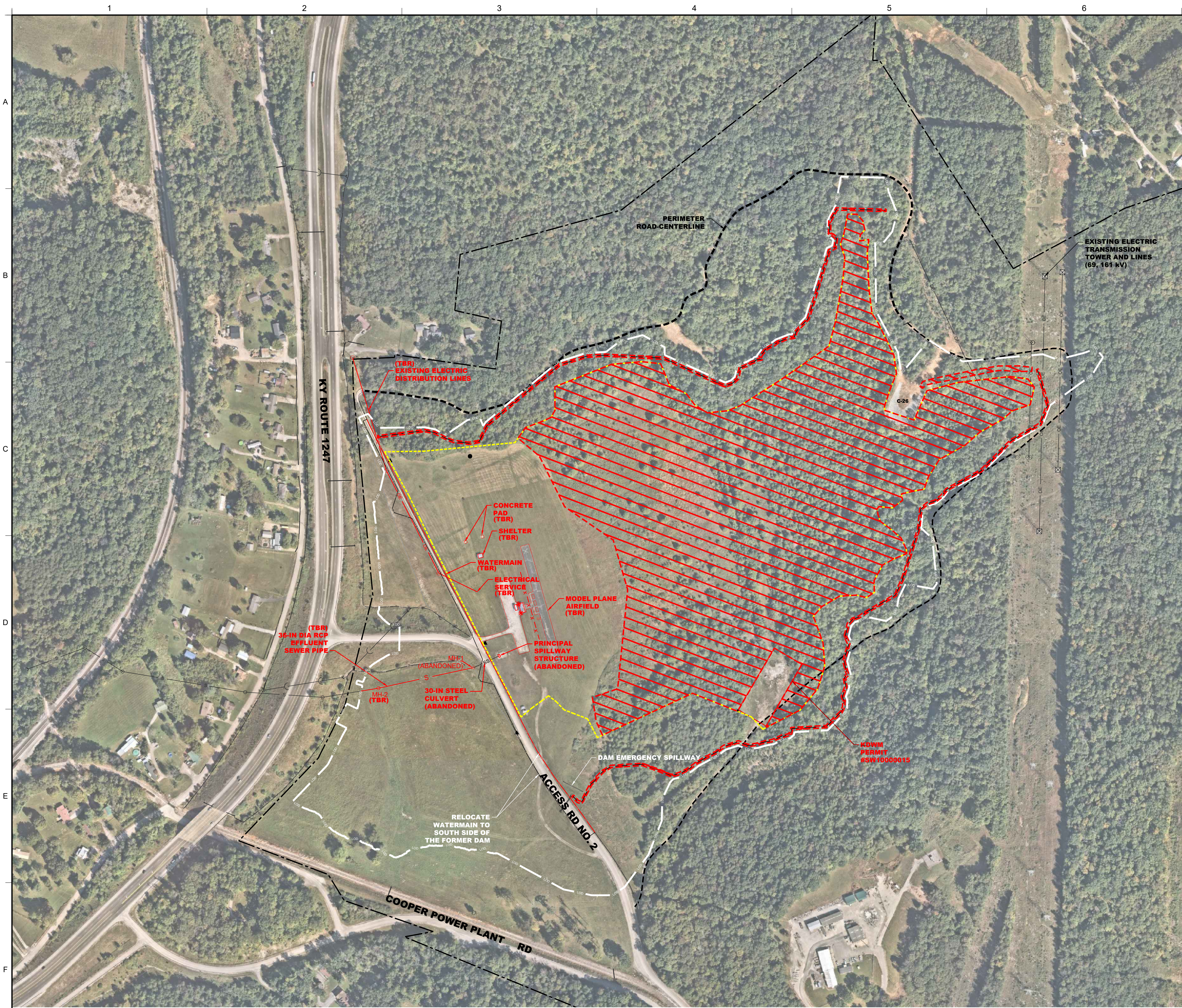

LEGEND

	PROPERTY BOUNDARY
	LIMITS OF CCB
	LIMIT OF DISTURBANCE
	EXISTING PERIMETER ROAD - CENTERLINE
	EXISTING OVERHEAD ELECTRIC LINE
	EXISTING DITCH
	EXISTING CHAIN LINK FENCE
	EXISTING CULVERT
	EXISTING 48" DIA EFFLUENT SEWER LINE
	ABANDONED EXISTING 48" DIA EFFLUENT SEWER LINE
	EXISTING ELECTRIC POLE
	EXISTING ELECTRIC TRANSMISSION TOWER
	EXISTING LIGHT POLE
	TP-29 EXPLORATION LOCATION
	PZ-13 PIEZOMETER LOCATION
	APPROXIMATE AREA OF CLEARING

- NOTES:**
- CLEARING LIMITS WERE DETERMINED BASED ON THE AERIAL MAP OF THE SITE. BRUSH AND TREES WITHIN THE DESIGNATED AREA "LIMITS OF CCB" SHALL ALL BE CLEARED.
 - STUMPS AND ROOTBALLS SHALL BE EXCAVATED AND BACKFILLED WITH ON-SITE MATERIALS. THE VEGETATION SHOULD BE CHIPPED AND HAULED OFFSITE.
 - THE CD&D LANDFILL SHALL BE EXCAVATED AND PLACED WITHIN AN AREA IDENTIFIED BY THE OWNER THAT IS LOCATED ON THE COOPER POWER STATION PROPERTY.
 - ITEMS IDENTIFIED AS TO BE REMOVED (TBR) OR REMOVAL AND REPLACEMENT SHALL BE COMPLETED IN ACCORDANCE WITH LOCAL STATE AND FEDERAL GUIDELINES IN APPROVED LANDFILLS. USE METHODS REQUIRED TO COMPLETE THE WORK WITHIN LIMITATION OF GOVERNING REGULATIONS INCLUDING OWNER SPECIFIC SAFETY REQUIREMENTS AND APPLICABLE STATE AND FEDERAL REQUIREMENTS.
 - ELECTRIC LINES ALONG THE FORMER DAM ARE DE-ENERGIZED, BUT THIS SHALL BE CONFIRMED BY THE CONTRACTOR.
 - THE CD&D LANDFILL SHALL BE EXCAVATED AND HAULED TO A SPECIFIED LOCATION ON-SITE.
 - TRANSMISSION LINES ARE ENERGIZED AND THE CONTRACTOR IS RESPONSIBLE FOR WORKING SAFELY IN ACCORDANCE WITH ALL LOCAL AND FEDERAL GUIDELINES IN THE VICINITY OF THE ENERGIZED TRANSMISSION LINES.
 - ANY ABANDONED STRUCTURES REMAINING IN PLACE SHALL BE REMOVED UP TO 2 FT BELOW THE SUBGRADE.
 - KARST FEATURES ENCOUNTERED DURING CLEARING AND/OR DEMOLITION WILL BE REPORTED IMMEDIATELY AND MITIGATED IN ACCORDANCE WITH SPECIFICATIONS.
 - NO CCB MATERIAL SHALL LEAVE THE LIMITS OF THE CCB.

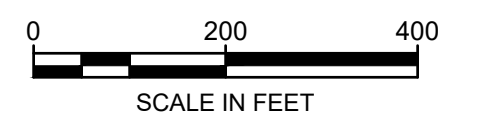

P:\KGL\1815-EMPC-COOPER FORMER IMPOUNDMENT DEMOLITION AND CLEARING PLAN

REV	DATE	DESCRIPTION	DRN	APP

1 MCBRIDE AND SON CENTER DRIVE, # 202
CHESTERFIELD, MISSOURI 63005
TELEPHONE: 636-812-0800

EAST KENTUCKY POWER COOPERATIVE
A Touchstone Energy Cooperative
4775 LEXINGTON RD., PO BOX 707
WINCHESTER, KY 40392

TITLE: DEMOLITION AND CLEARING

PROJECT: EAST KENTUCKY POWER COOPERATIVE COOPER FORMER IMPOUNDMENT CLOSURE DESIGN

SITE: COOPER POWER STATION, SOMERSET, KENTUCKY

DESIGN BY:	ZJF	DATE:	MAY 2023
DRAWN BY:	TMM	PROJECT NO.:	GPL8015
CHECKED BY:	TWW	FILE:	
REVIEWED BY:	TWW	DRAWING NO.:	
APPROVED BY:	JPS	3 OF 18	

90% DESIGN DRAWINGS - NOT FOR CONSTRUCTION

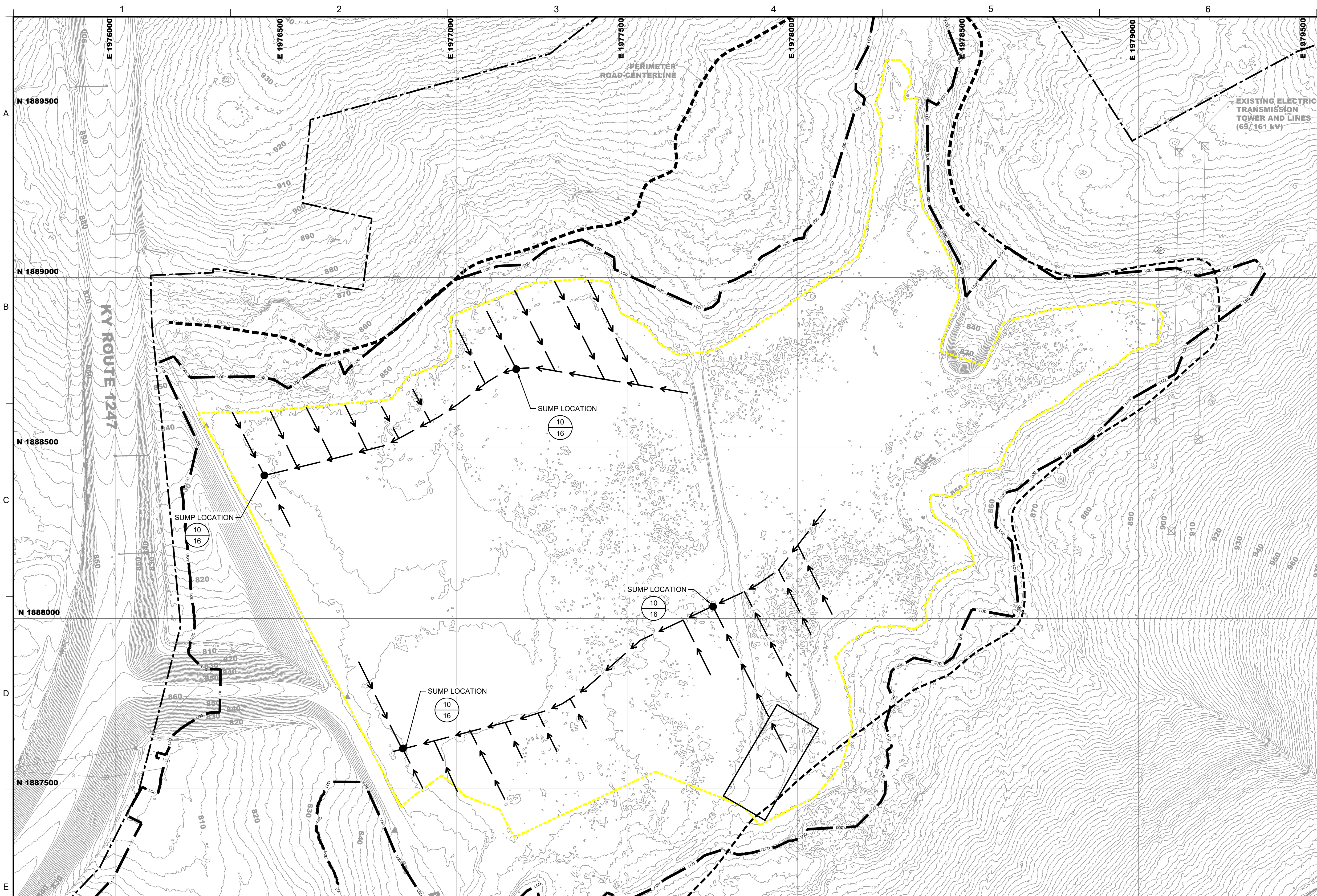

LEGEND

	PROPERTY BOUNDARY
	EXISTING PERIMETER ROAD - CENTERLINE
	PRECONSTRUCTION GROUND SURFACE ELEVATION (2- FT INTERVAL)
	PRECONSTRUCTION GROUND SURFACE ELEVATION (10- FT INTERVAL)
	EXISTING OVERHEAD ELECTRIC LINE
	EXISTING DITCH
	EXISTING CHAIN LINK FENCE
	EXISTING CULVERT
	EXISTING 48" DIA EFFLUENT SEWER LINE
	ABANDONED EXISTING 48" DIA EFFLUENT SEWER LINE
	LOD
	EXISTING ELECTRIC POLE
	EXISTING ELECTRIC TRANSMISSION TOWER
	EXISTING LIGHT POLE
	TP-29
	EXPLORATION TEST PIT OR BORING LOCATION
	PIEZOMETER LOCATION
	HAND AUGER PROBE
	LIMITS OF CCB
	DEWATERING DITCHES
	SUMP LOCATION

- NOTES:**
- DEWATERING DITCHES SHALL BE CONSTRUCTED WITH SIDE SLOPES NO STEEPER THAN 2H:1V.
 - DEWATERING DITCHES SHALL BE CONSTRUCTED TO SUCH A DEPTH THAT THE PHREATIC SURFACES IS DRAWN DOWN TO A MINIMUM OF FIVE FEET BELOW THE WORKING SURFACE. THE CONTRACTOR IS RESPONSIBLE FOR EVALUATION OF THE SEPARATION BASED ON THE CONTRACTOR PROJECT PLAN TO MAINTAIN A SAFE WORKING SURFACE.
 - DEWATERING DITCHES SHALL BE LOWERED DURING CONSTRUCTION SUCH THAT A MINIMUM OF 5 FT OF SEPARATION IS MAINTAINED BETWEEN THE WORKING SURFACE AND THE PHREATIC SURFACE.
 - THE EXTENT OF ALL DEWATERING DITCHES IS SHOWN SUCH THAT AREAS WHERE THE ESTIMATED PHREATIC SURFACE IS LESS THAN FIVE FEET FROM THE FINAL SURFACE.
 - DEWATERING DITCHES PERPENDICULAR TO THE FINAL DITCH LINE (I.E. DITCHES RUNNING NORTHWEST TO SOUTHEAST) ARE SHOWN WITH A SPACING OF 100 FEET AND ARE LOCATED AS NEEDED, BASED ON ESTIMATED PHREATIC CONDITIONS.
 - MODIFICATIONS AND/OR ADDITIONS TO THE DEWATERING LAYOUT, INCLUDING EXTENTS, SIDE SLOPES, DEPTHS, AND WIDTHS OF DITCHES, AS WELL AS THE NUMBER OF SUMPS SHOULD BE ALTERED IN THE FIELD, AS NEEDED, TO PROVIDE A MINIMUM OF FIVE FEET OF SEPARATION BETWEEN THE WORKING SURFACE AND THE PHREATIC SURFACE.
 - MAINTAINING A FIVE-FOOT SEPARATION BETWEEN THE WORKING SURFACE AND THE PHREATIC SURFACE, STABLE TRENCH SLOPES/EXCAVATIONS, DRAINAGE TO SUMPS, ETC. SHALL BE THE RESPONSIBILITY OF THE CONTRACTOR.
 - ALL DEWATERING WATERS SHALL BE PUMPED TO AN ONSITE TREATMENT FACILITY. TREATMENT METHOD AND FACILITY LOCATION ARE TO BE DETERMINED.

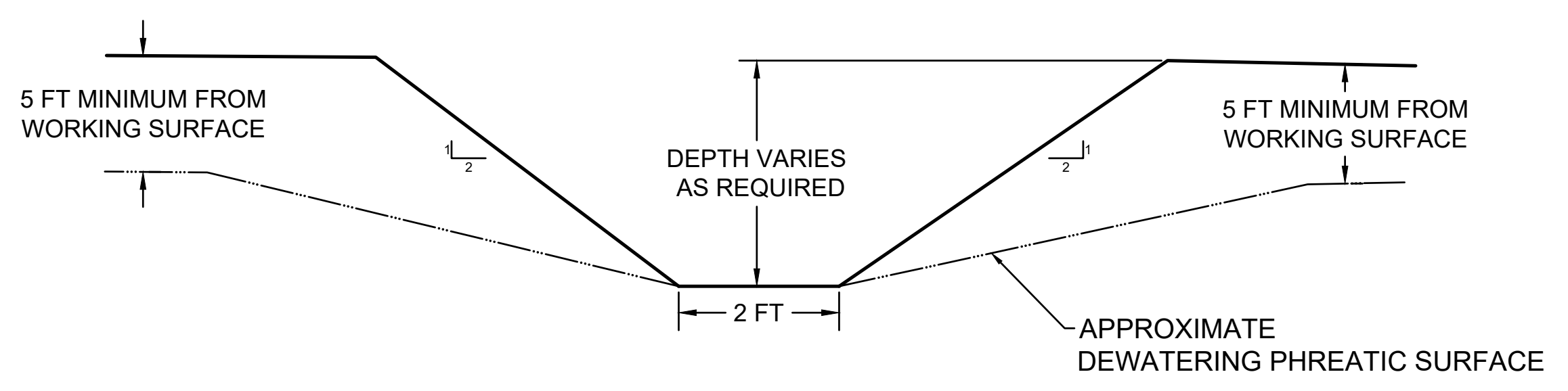
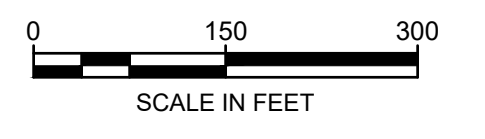

1 DETAIL
4 DEWATERING DITCH CROSS-SECTION
 N.T.S

90% DESIGN DRAWINGS - NOT FOR CONSTRUCTION

REV	DATE	DESCRIPTION	DRN	APP
1 MCBRIDE AND SON CENTER DRIVE, # 202 CHESTERFIELD, MISSOURI 63005 TELEPHONE: 636-812-0800				
4775 LEXINGTON RD., PO BOX 707 WINCHESTER, KY 40392				
TITLE:		CONCEPTUAL DEWATERING PLAN		
PROJECT:		EAST KENTUCKY POWER COOPERATIVE COOPER FORMER IMPOUNDMENT CLOSURE DESIGN		
SITE:		COOPER POWER STATION, SOMERSET, KENTUCKY		
DESIGN BY:	ZJF	DATE:	MAY 2023	
DRAWN BY:	MGK	PROJECT NO.:	GPL8015	
CHECKED BY:	TWW	FILE:		
REVIEWED BY:	TWW	DRAWING NO.:		
APPROVED BY:	JPS	4 OF 18		

P:\KIP\1515-BP-COOPER-LEGACY-FOND-CONTRACTOR-WORKING-DRAWINGS\15151504-CONCEPTUAL-DEWATERING-PLAN

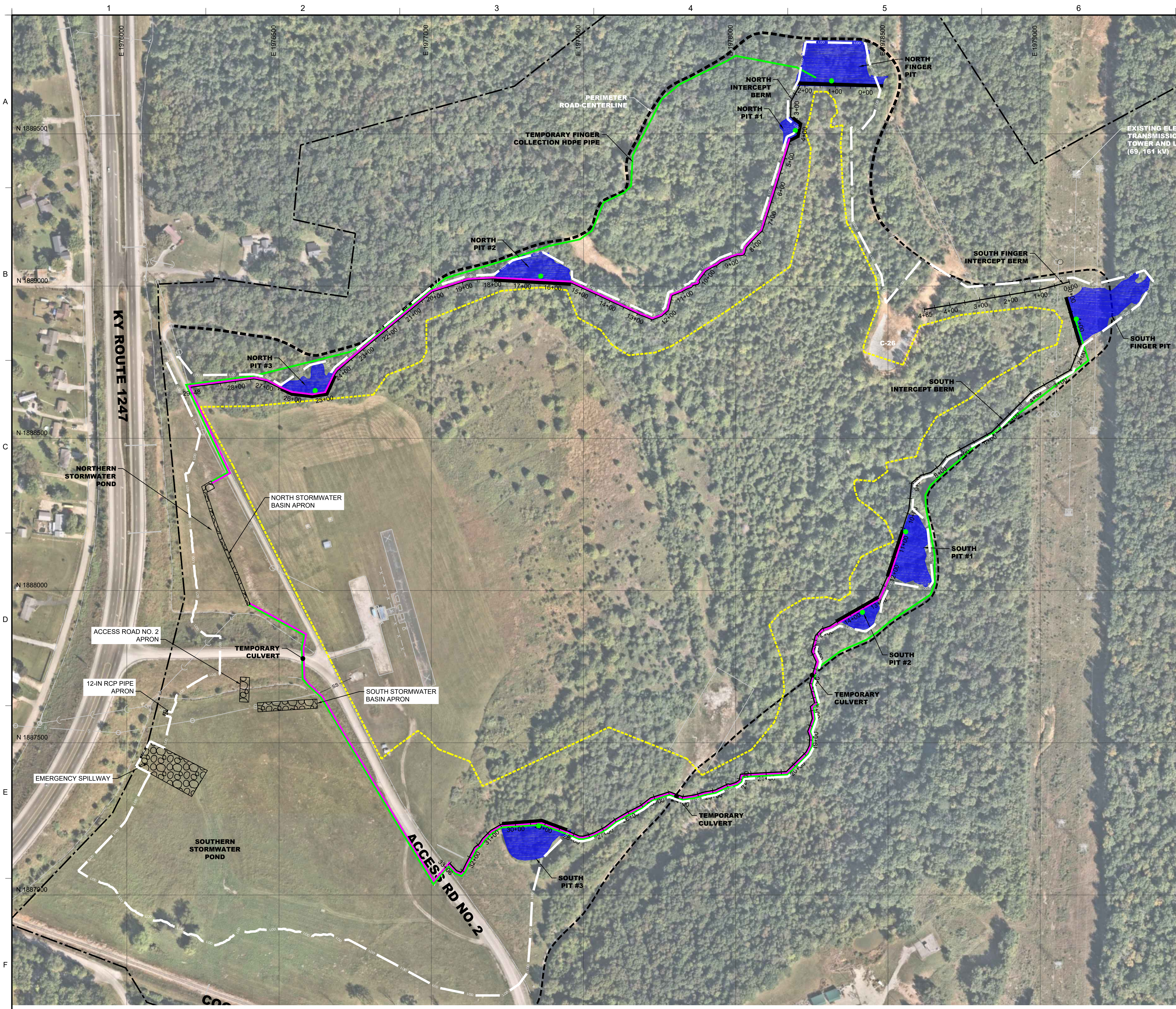

LEGEND

- PROPERTY BOUNDARY
- EXISTING PERIMETER ROAD - CENTERLINE
- LIMITS OF CCB
- EXISTING OVERHEAD ELECTRIC LINE
- EXISTING DITCH
- EXISTING CHAIN LINK FENCE
- EXISTING CULVERT
- EXISTING 48" DIA EFFLUENT SEWER LINE
- ABANDONED EXISTING 48" DIA EFFLUENT SEWER LINE
- LOD
- EXISTING ELECTRIC POLE
- EXISTING ELECTRIC TRANSMISSION TOWER
- EXISTING LIGHT POLE
- COLLECTION PIT
- INTERCEPT BERM
- COLLECTION PIT BERMS
- HDPE PIPE - FINGER TO SOUTH BASIN
- HDPE PIPE - COLLECTION PITS TO SOUTH BASIN
- APPROXIMATE EXPECTED RETAINED WATER IN COLLECTION PIT POOL

- NOTES:**
1. STORMWATER INTERCEPT BERMS ARE TO SEGREGATE CONTACT WATER FROM NON-CONTACT STORMWATER AND SHALL BE CONSTRUCTED FROM CLAY MATERIALS PRESENT ONSITE AND ACCORDING TO THE FOLLOWING:
 - a. DITCH SHALL BE DUG ALONG THE APPROXIMATE ALIGNMENT SHOWN WITH A MINIMUM DEPTH OF ONE FOOT AND MINIMUM WIDTH OF TWO FEET.
 - b. THE MATERIAL FROM THE DITCH EXCAVATION SHALL BE PLACED AND COMPACTED TO FORM AN APPROXIMATELY ONE FOOT TALL BERM ON THE DOWNHILL SIDE OF THE DITCH.
 - c. THE ALIGNMENT AND ELEVATIONS OF THE INTERCEPT BERMS SHOWN ARE APPROXIMATE AND SHOULD BE ADJUSTED BY THE CONTRACTOR DURING CONSTRUCTION TO PROMOTE DRAINAGE TO THE STORMWATER COLLECTION PITS AND AVOID LOW AREAS THAT MAY HOLD WATER.
 2. STORMWATER COLLECTION PIT BERMS SHALL BE CONSTRUCTED FROM CLAYEY TO CLAY MATERIALS PRESENT ONSITE AND ACCORDING TO THE FOLLOWING:
 - a. STORMWATER COLLECTION BERMS SHALL BE CONSTRUCTED TO THE ELEVATION INDICATED.
 - b. SIDE SLOPES SHALL BE NO STEEPER THAN 2H:1V.
 - c. THE CREST WIDTH, PERPENDICULAR TO THE BERM AND INTERCEPT BERM ALIGNMENT, SHALL BE AT LEAST 2 FT WIDE.
 - d. THE COLLECTION PIT BERMS SHALL BE CONSTRUCTED IN LOOSE LIFTS OF NO MORE THAN 12 INCHES THICK AND COMPACTED TO NO MORE THAN 9 INCHES THICK UNTIL THE DESIRED ELEVATION IS REACHED.
 3. STORMWATER COLLECTION PITS SHALL BE INSTALLED AT THE LOWEST POINT IN EACH COLLECTION PIT POOL TO PROVIDE A POINT WHERE PUMPS OR SUCTION LINES CAN BE PLACED TO MITIGATE PUMPED SEDIMENT AND DEBRIS.
 - a. STORMWATER COLLECTION PITS SHALL CONSIST OF A GEOTEXTILE WRAPPED PIPE AS DESCRIBED FOR DEWATERING ON SHEET 19.
 - b. THE TOP OF COLLECTION PIT SHALL NOT EXTEND VERTICALLY WITHIN 2 FT OF THE STORMWATER COLLECTION PIT BERM CREST.
 4. STORMWATER COLLECTION SYSTEM MAINTENANCE SHALL BE THE RESPONSIBILITY OF THE CONTRACTOR AND SHALL INCLUDE, AT A MINIMUM:
 - a. WEEKLY INSPECTIONS, AND POST-STORM EVENT INSPECTIONS, TO ASSESS EROSION, SILTING, HDPE PIPE INTEGRITY, ETC.
 - b. EXCAVATING EXCESS SILTED MATERIALS THAT MAY ACCUMULATE IN THE COLLECTION PITS AND POOLS AND ALONG THE INTERCEPT BERMS.
 - c. REPAIRS TO ERODED AREAS.
 5. PROPOSED CULVERTS SHALL BE LARGE ENOUGH TO CARRY STORMWATER FLOWS ALONG THE STORMWATER INTERCEPT BERMS, AS WELL AS HOUSE BOTH HDPE PIPES BENEATH THE RE-ROUTED PERIMETER ROAD.
 - a. PROPOSED CULVERT MATERIALS ARE AT THE DISCRETION OF THE CONTRACTOR.
 6. CONTRACTOR SHALL SUBMIT A TEMPORARY PERIMETER STORMWATER CONTROL PLAN, THAT INCLUDES ALL SEQUENCING OF STORMWATER CONTROLS FOR CONSTRUCTION THAT SHALL AT A MINIMUM MEET THAT PLAN OUTLINED HERE.

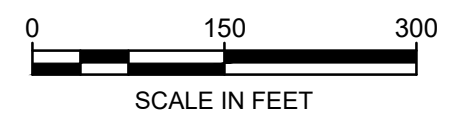

REV	DATE	DESCRIPTION	DRN	APP

1 MCBRIDE AND SON CENTER DRIVE, # 202
CHESTERFIELD, MISSOURI 63005
TELEPHONE: 636-812-0800

4775 LEXINGTON RD., PO BOX 707
WINCHESTER, KY 40392

TITLE: TEMPORARY PERIMETER STORMWATER CONTROL SYSTEM PLAN VIEW

PROJECT: EAST KENTUCKY POWER COOPERATIVE COOPER FORMER IMPOUNDMENT CLOSURE DESIGN



SITE: COOPER POWER STATION, SOMERSET, KENTUCKY

DESIGN BY:	ZJF	DATE:	MAY 2023
DRAWN BY:	MGK	PROJECT NO.:	GPL8015
CHECKED BY:	TWW	FILE:	
REVIEWED BY:	TWW	DRAWING NO.:	
APPROVED BY:	JPS		

90% DESIGN DRAWINGS - NOT FOR CONSTRUCTION

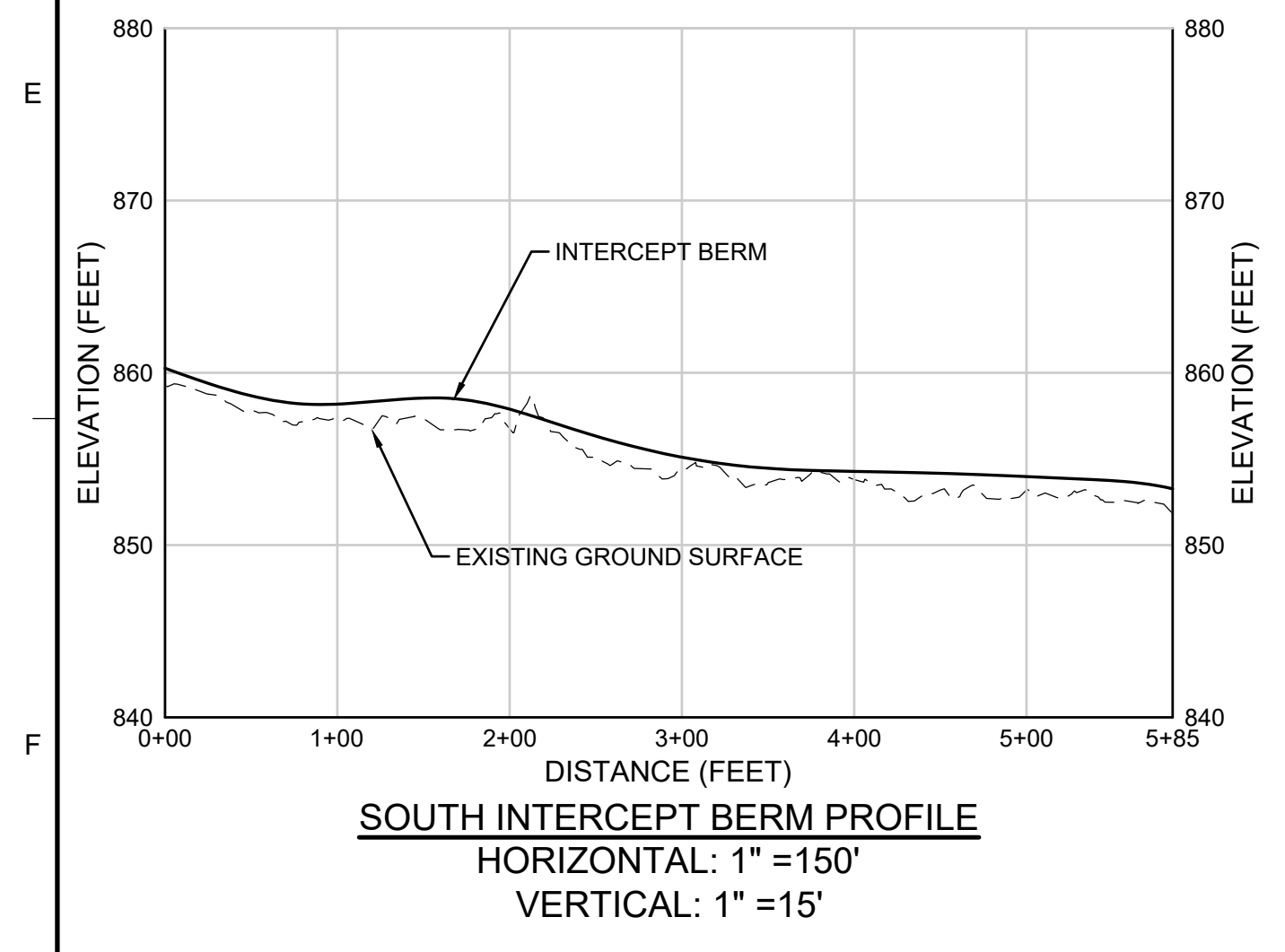
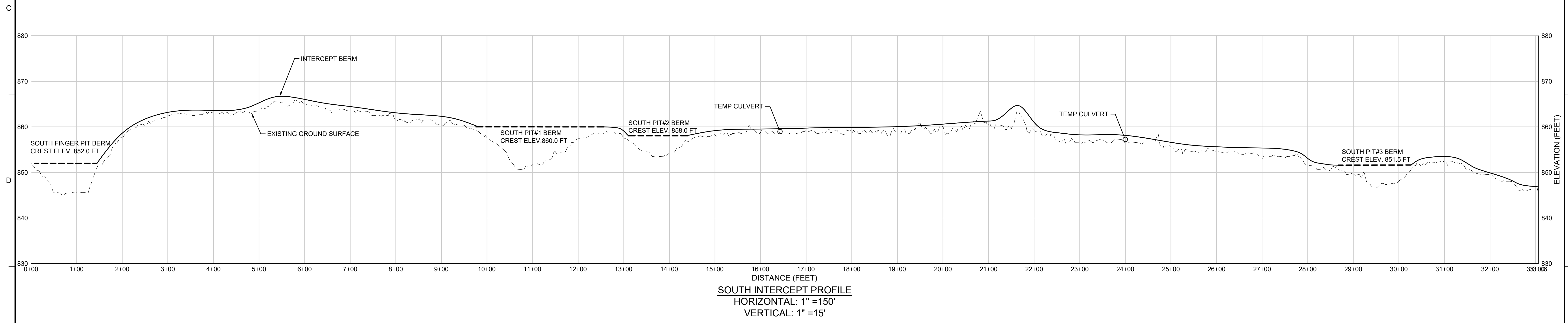
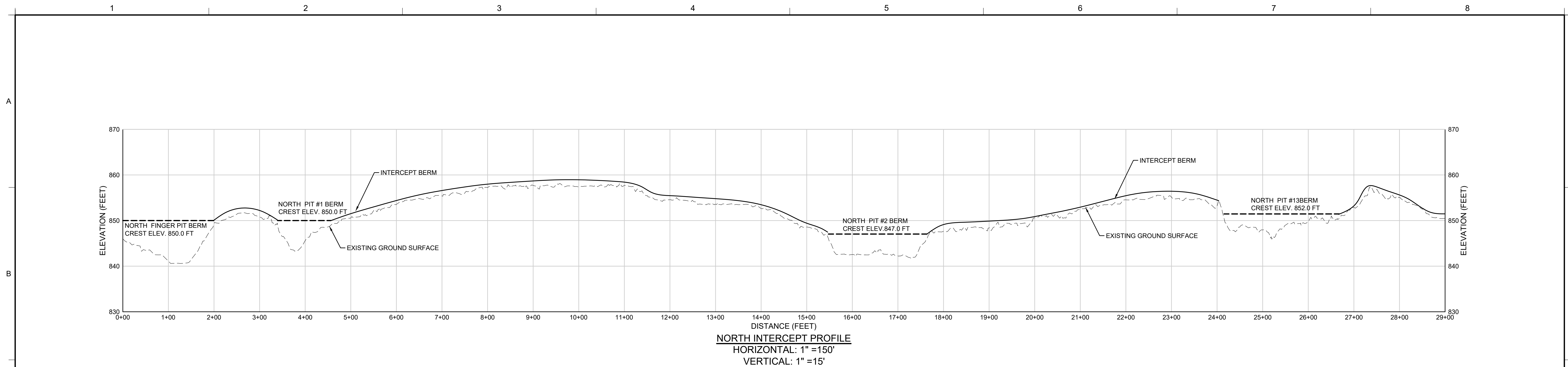
P:\KIDPIS\BSPIC\COOPER\CONTRACTOR WORKING DRAWINGS\PLANS\15052006 STORMWATER CONTROL PLAN



REV	DATE	DESCRIPTION	DRN	APP
 				
<small>1 MCBRIDE AND SON CENTER DRIVE, # 202 CHESTERFIELD, MISSOURI 63005 TELEPHONE: 636-812-0800</small>				
<small>4775 LEXINGTON RD., PO BOX 707 WINCHESTER, KY 40392</small>				
TITLE: PERIMETER STORMWATER CONTROL SYSTEM PROFILES				
PROJECT: EAST KENTUCKY POWER COOPERATIVE COOPER FORMER IMPOUNDMENT CLOSURE DESIGN				
SITE: COOPER POWER STATION, SOMERSET, KENTUCKY				
DESIGN BY: ZJF		DATE: MAY 2023		
DRAWN BY: MGK		PROJECT NO.: GPL8015		
CHECKED BY: TWW		FILE:		
REVIEWED BY: TWW		DRAWING NO.:		
APPROVED BY: JPS		6 OF 18		

90% DESIGN DRAWINGS - NOT FOR CONSTRUCTION

P:\KGLP\15-EPCC COOPER FORMER IMPONDMENT CLOSURE DESIGN\15-000-000-015 STORMWATER CONTROL PLAN

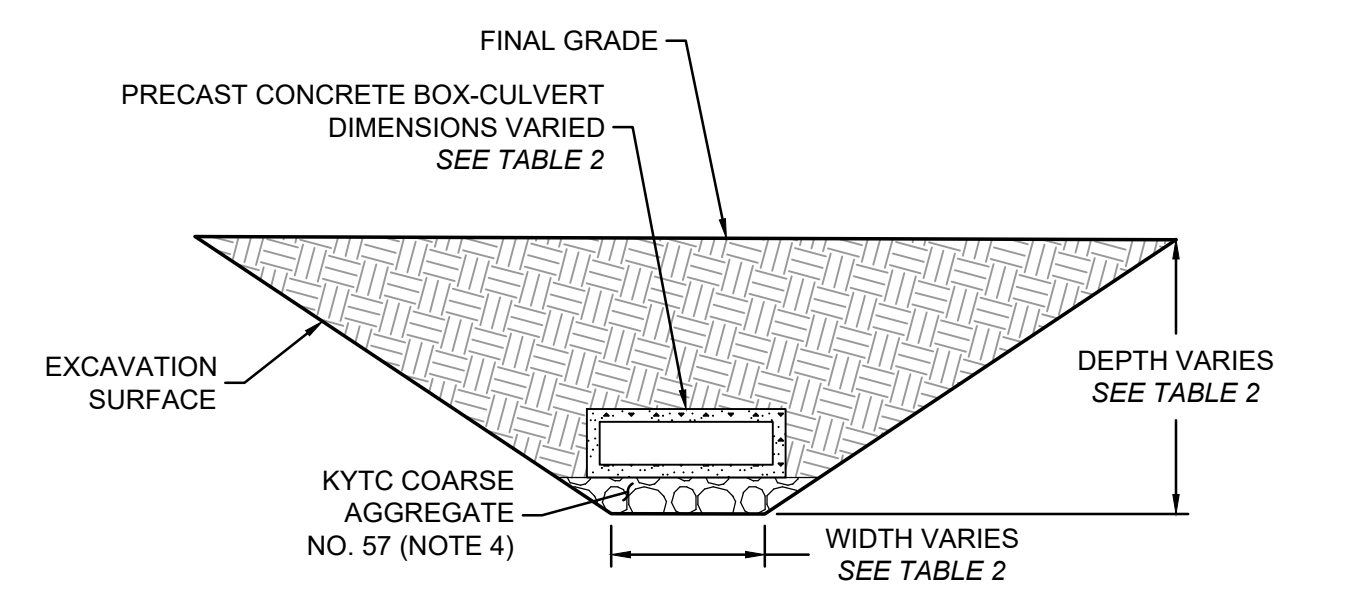
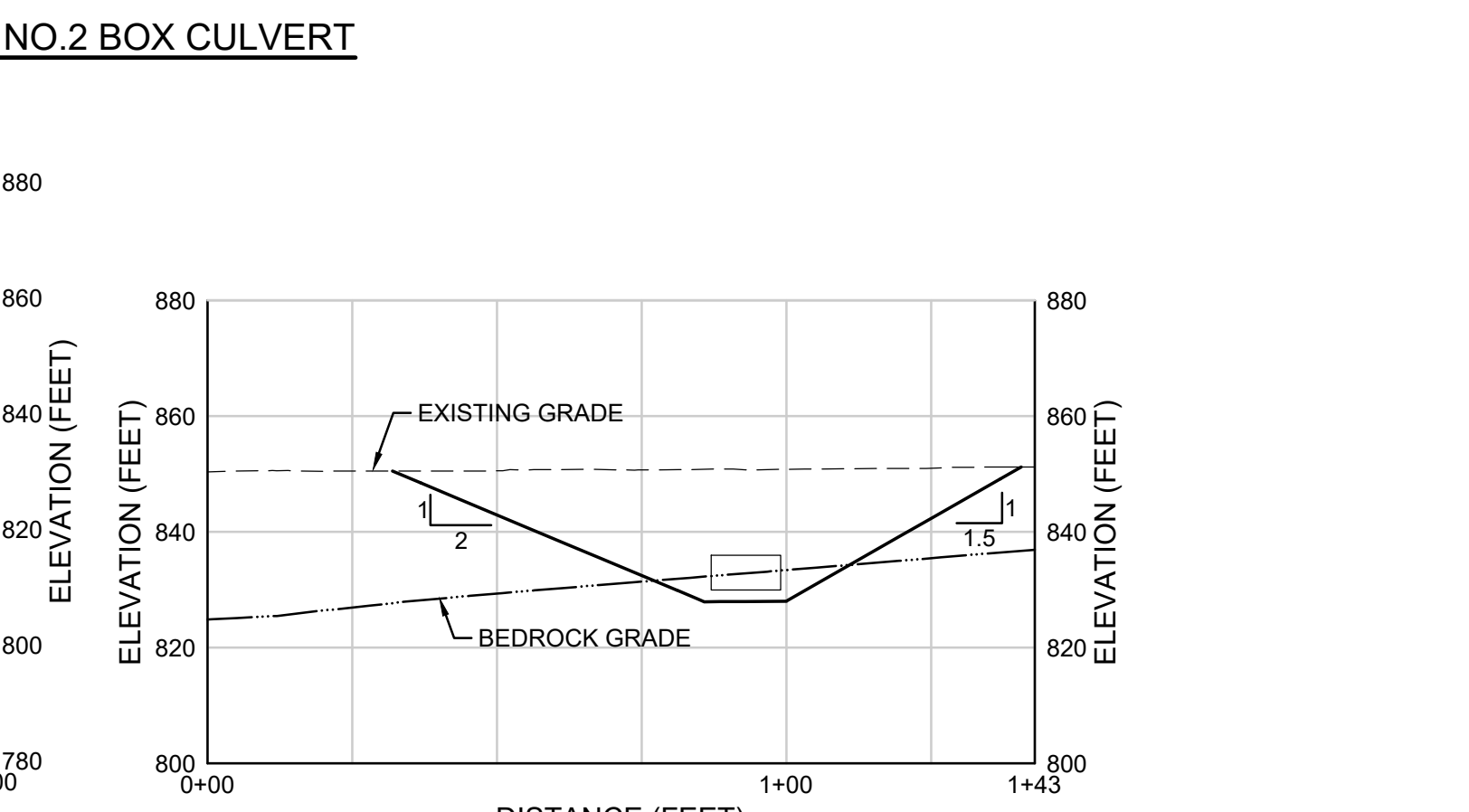
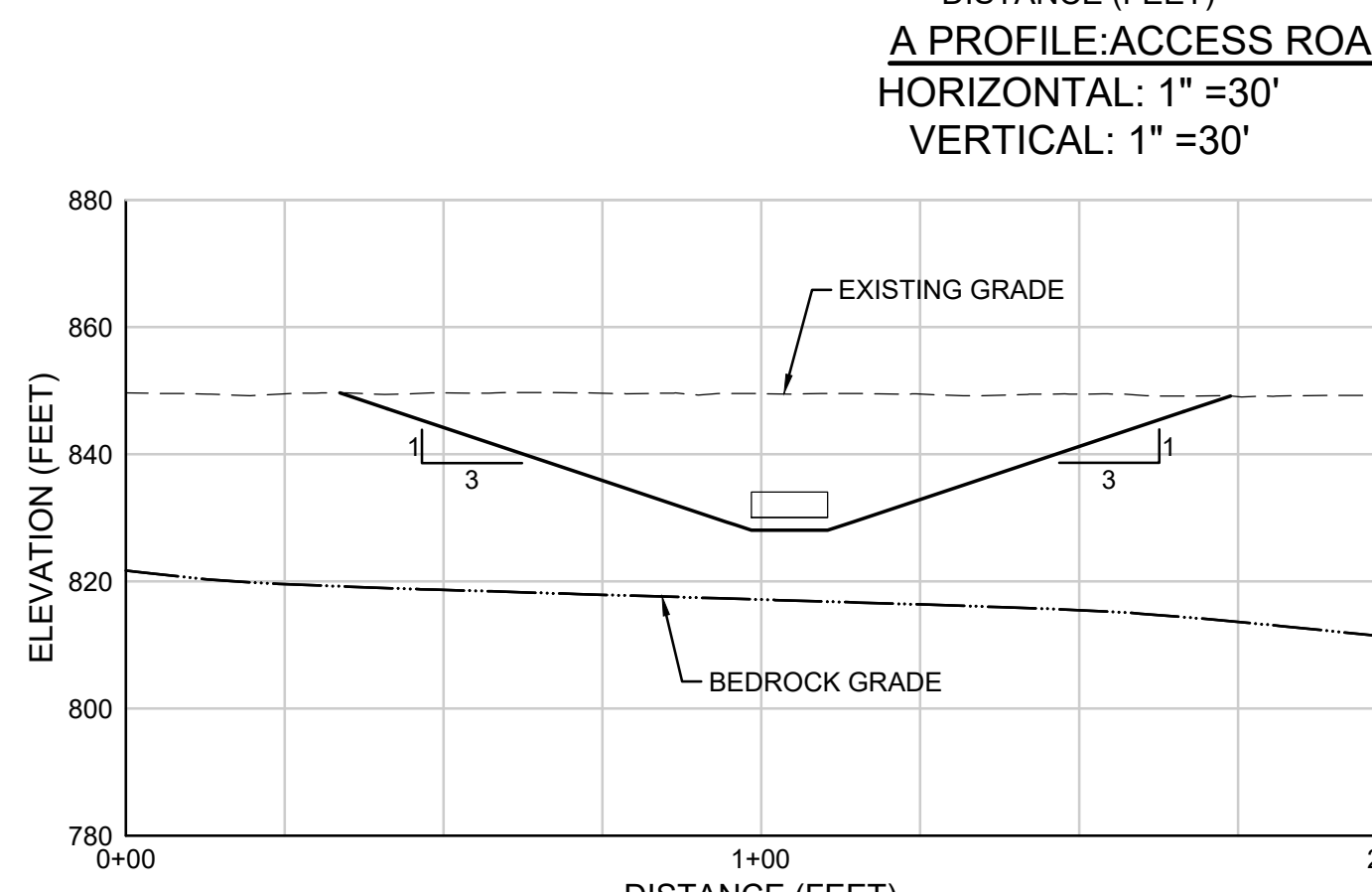
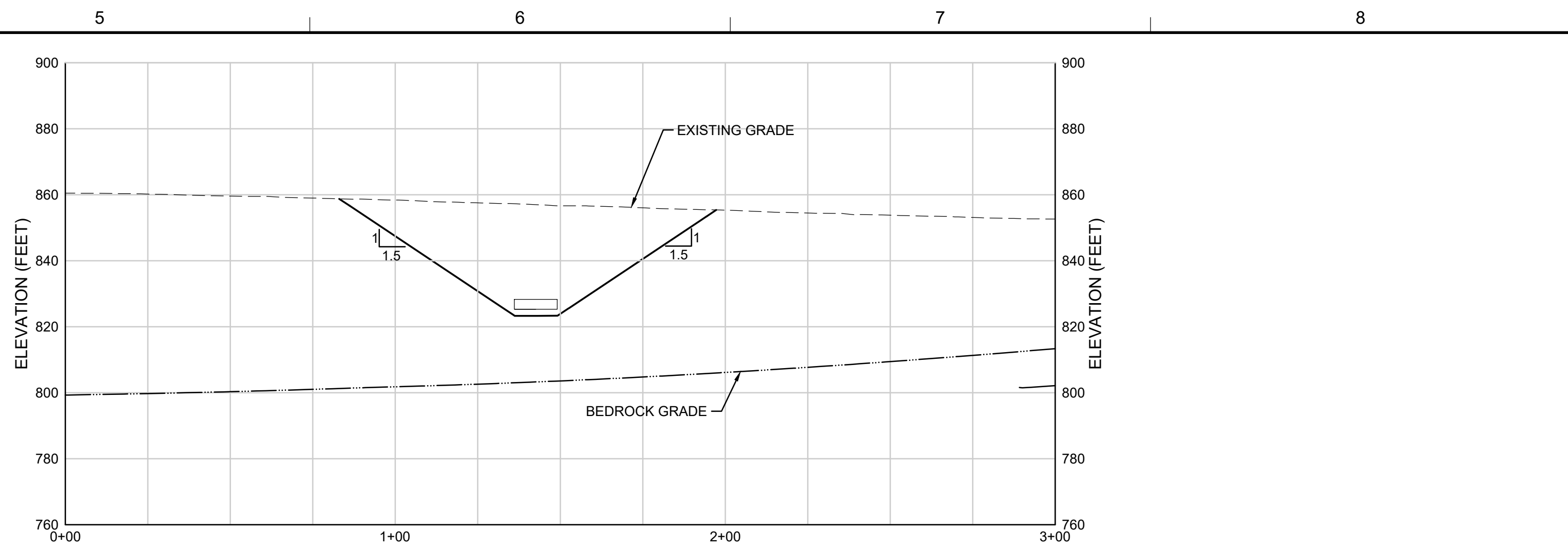
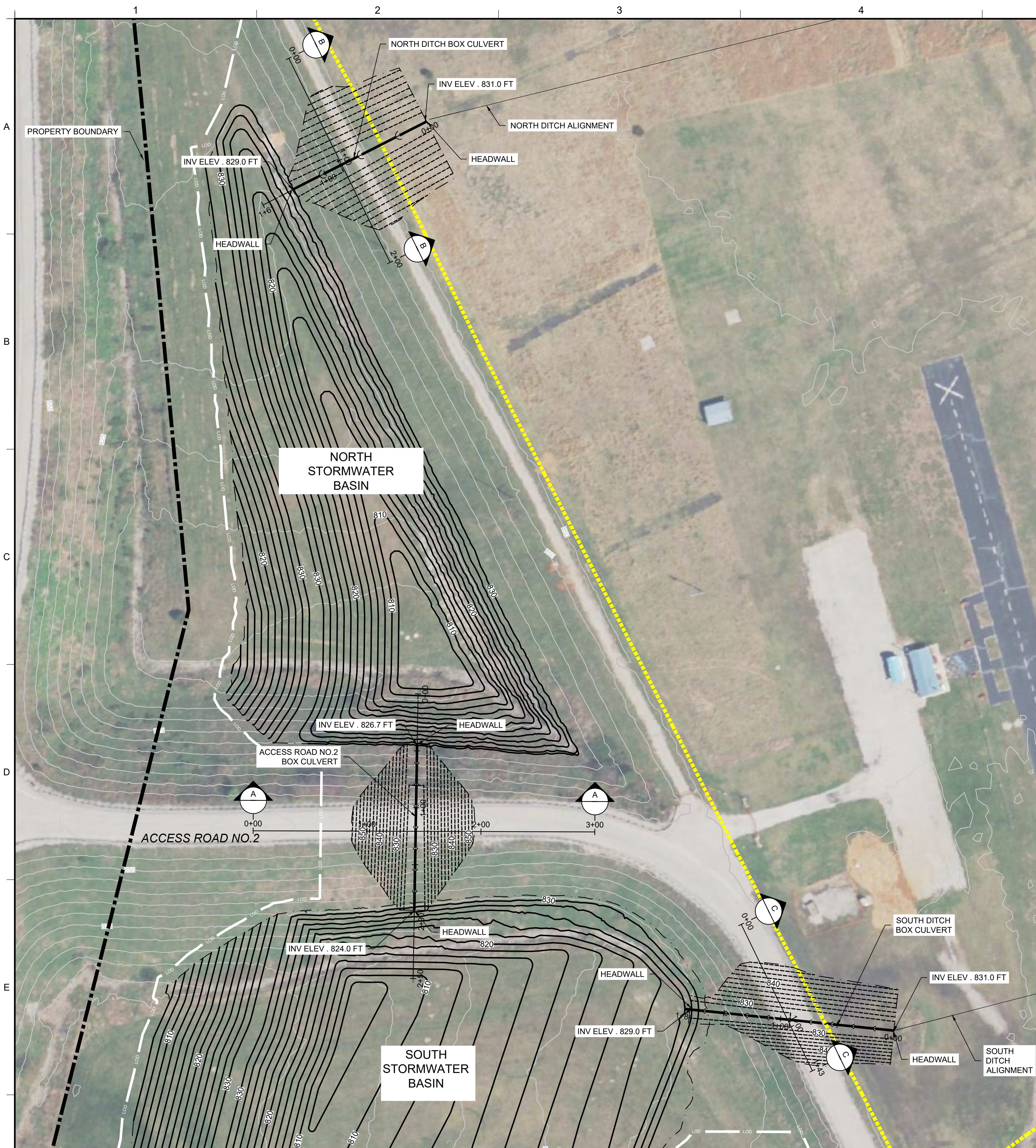

2 **7** **DETAIL**
PRECAST BOX CULVERT (TYP.)
N.T.S.

TABLE 2:

BOX CULVERT	SIZE	KYHL-93 TABLE
SOUTH DITCH BOX CULVERT	8 FT BY 6 FT	8x6x8 DESIGN EARTH COVER, FT=15 TO 20
NORTH DITCH BOX CULVERT	8 FT BY 4 FT	8x4x8 DESIGN EARTH COVER, FT=15 TO 20
ACCESS ROAD NO. 2 BOX CULVERT	TRIPLE 5 FT BY 3 FT	5X3X6 DESIGN EARTH COVER, FT=25 TO 20

- NOTES:**
- ALL BOX CULVERTS SHALL BE INSTALLED USING CUT AND COVER TECHNIQUES.
 - ALL EXCAVATION SLOPES SHALL BE NO STEEPER THAN THOSE SHOWN HERE. FLATTER SLOPES ARE ACCEPTABLE AT THE CONTRACTOR'S DISCRETION.
 - ALL EXCAVATION SHALL BE TWO FEET WIDER THAN THE OUTER DIMENSIONS OF THE RESPECTIVE BOX CULVERT SUCH THAT THERE IS ONE FOOT OF BEDDING MATERIAL EXTENDING PAST THE EDGE OF CONCRETE ON EITHER SIDE.
 - ALL BOX CULVERTS SHALL BE BEDDED ON NO LESS THAN 12 INCHES OF KYTC COARSE AGGREGATE NO. 57.
 - CONSTRUCTION AND INSTALLATION OF THE PRECAST BOX CULVERTS SHALL BE IN ACCORDANCE WITH SECTION 611 PRECAST REINFORCED CONCRETE BOX CULVERT SECTIONS OF THE KYTC STANDARD SPECIFICATIONS FOR ROAD AND BRIDGE CONSTRUCTION.
 - DIMENSIONS AND REINFORCEMENT SHALL BE IN ACCORDANCE WITH KYHL-93 TABLE 1.
 - SEE KYTC STANDARD DRAWING NO. RDI-120-04 BEDDING FOR PRECAST BOX CULVERTS, SEWERS, STORM DRAINS, AND THEIR COMBINATIONS.
 - CONTRACTOR SHALL PROVIDE SHOP DRAWINGS FOR PRECAST BOX CULVERTS FOR APPROVAL BY THE ENGINEER.
 - CONTRACTOR SHALL EXCAVATE LOOSE MATERIAL FROM ANY OBSERVED SWALLETS OR OTHER KARST FEATURES WITHIN THE LIMITS OF DISTURBANCE. THE BEDROCK SURFACE SHALL BE EXPOSED AND A GRADED ROCK FILTER SHALL BE PLACED AS APPROVED BY THE ENGINEER.

LEGEND

	PROPERTY BOUNDARY
	PRECONSTRUCTION GROUND SURFACE ELEVATION (2- FT INTERVAL)
	PRECONSTRUCTION GROUND SURFACE ELEVATION (10- FT INTERVAL)
	FINAL GRADE ELEVATION (2- FT INTERVAL)
	EXCAVATION GRADE ELEVATION (2- FT INTERVAL)
	LIMITS OF CCB

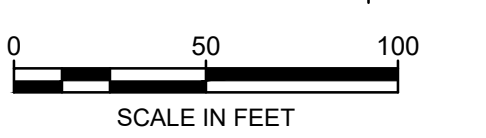

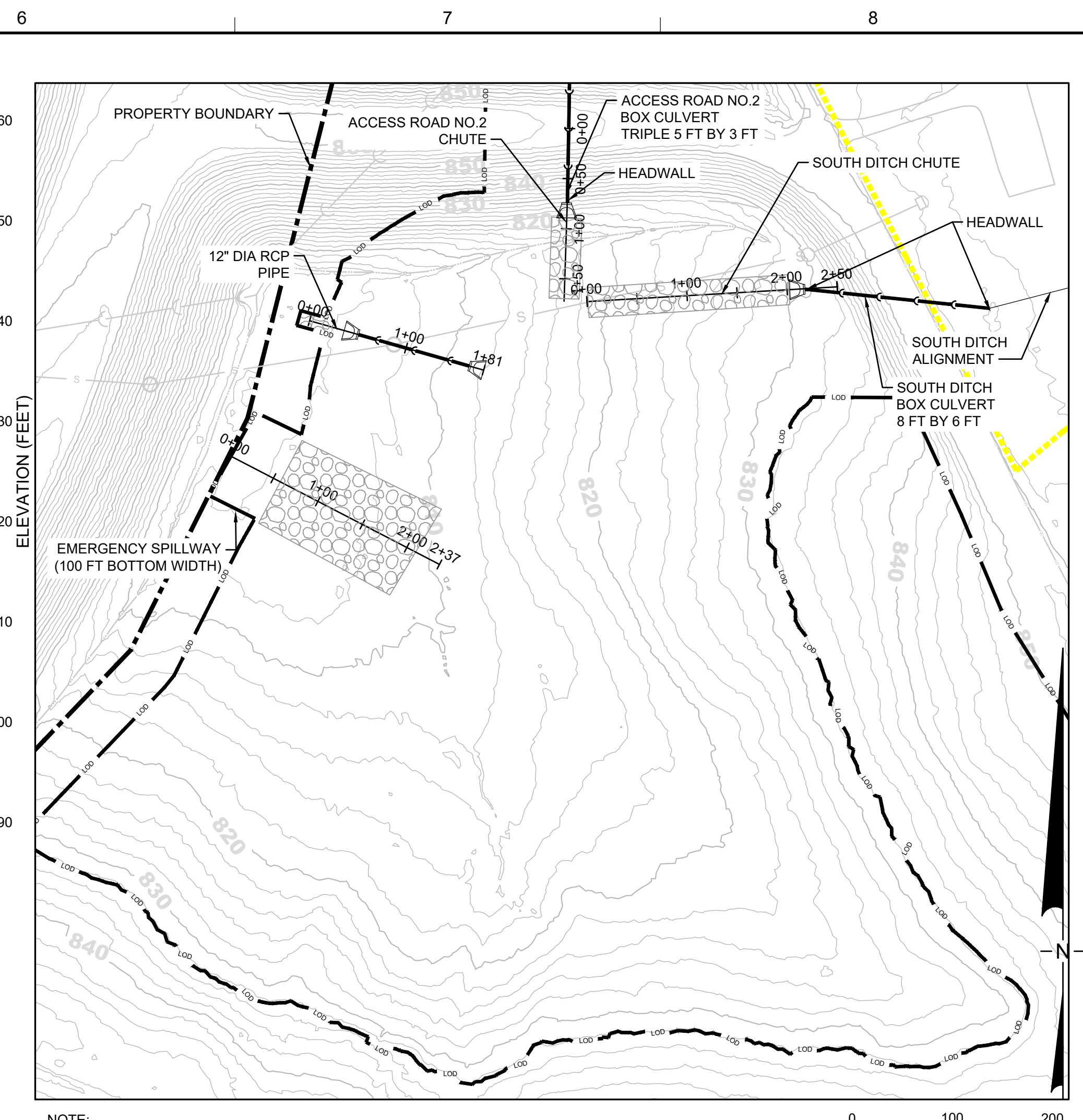
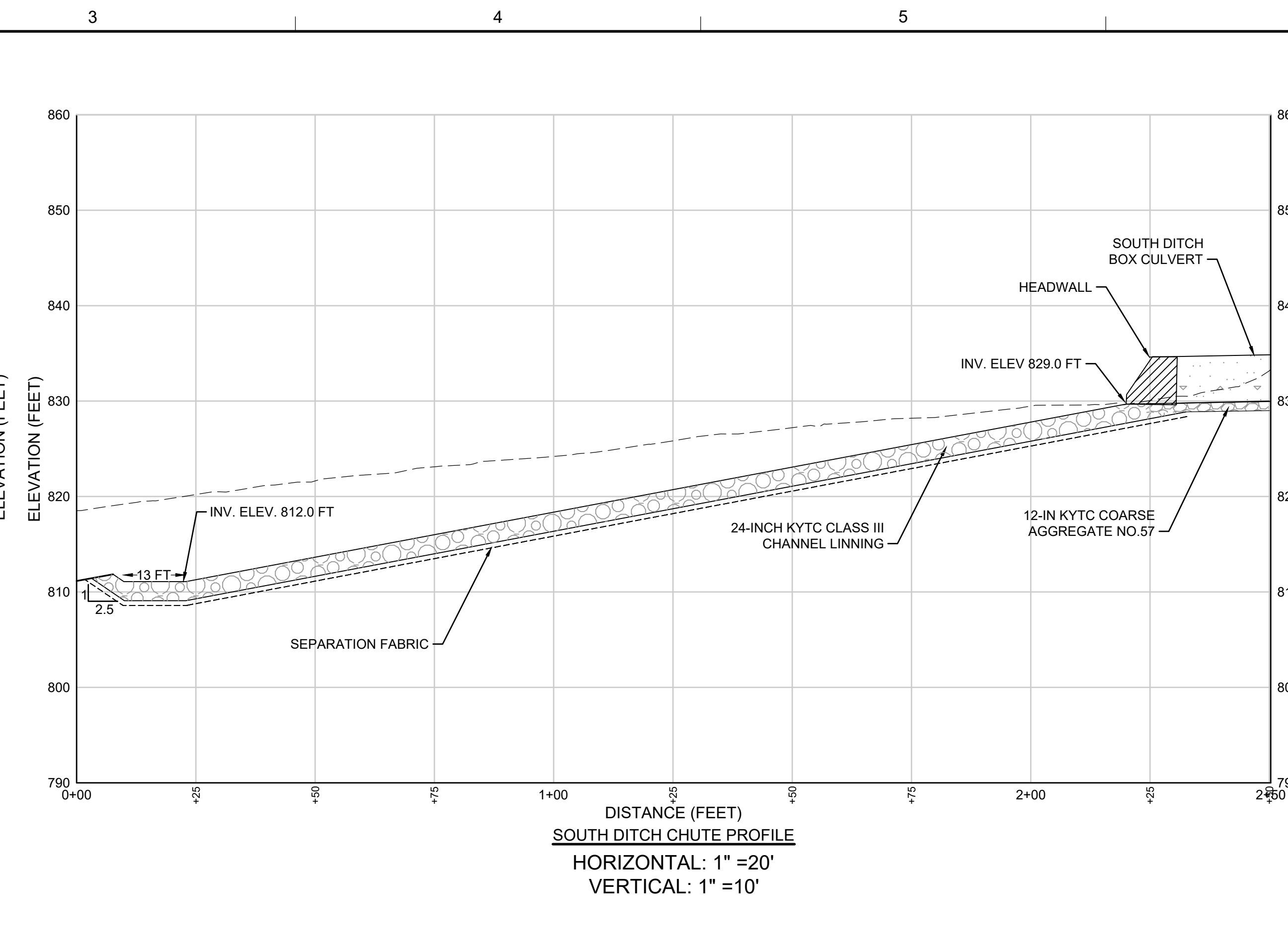
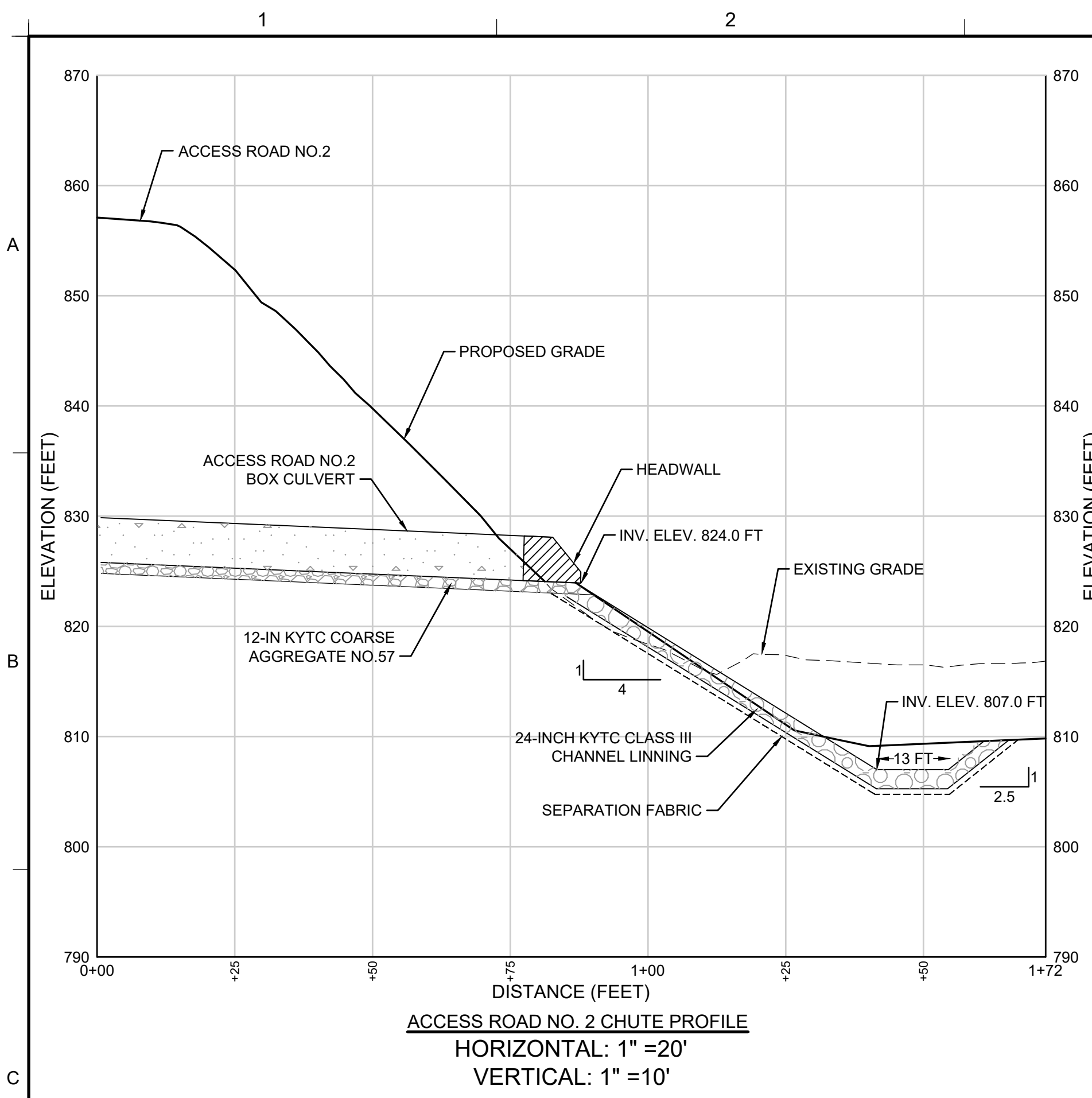

90% DESIGN DRAWINGS - NOT FOR CONSTRUCTION

REV	DATE	DESCRIPTION	DRN	APP
<p>1 MCBRIDE AND SON CENTER DRIVE, # 202 CHESTERFIELD, MISSOURI 63005 TELEPHONE: 636-812-0800</p> <p>4775 LEXINGTON RD., PO BOX 707 WINCHESTER, KY 40392</p>				
<p>TITLE: BOX CULVERTS PLAN VIEW, SECTIONS AND DETAILS</p>				
<p>PROJECT: EAST KENTUCKY POWER COOPERATIVE COOPER FORMER IMPOUNDMENT CLOSURE DESIGN</p>				
<p>SITE: COOPER POWER STATION, SOMERSET, KENTUCKY</p>				
DESIGN BY: ZJF		DATE: MAY 2023		
DRAWN BY: MGK		PROJECT NO.: GPL8015		
CHECKED BY: TWW		FILE:		
REVIEWED BY: TWW		DRAWING NO.:		
APPROVED BY: JPS		<p>7 OF 18</p>		

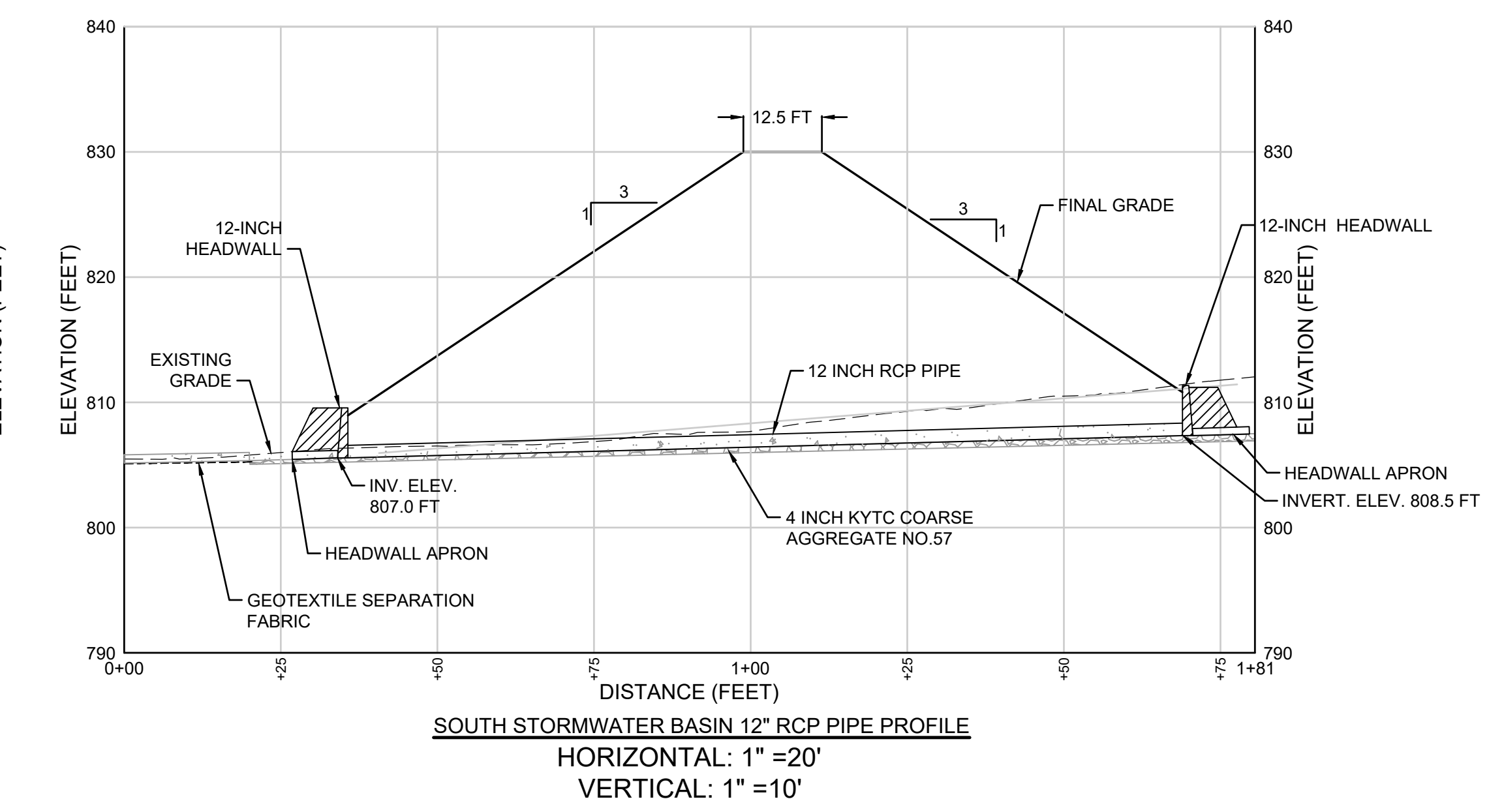
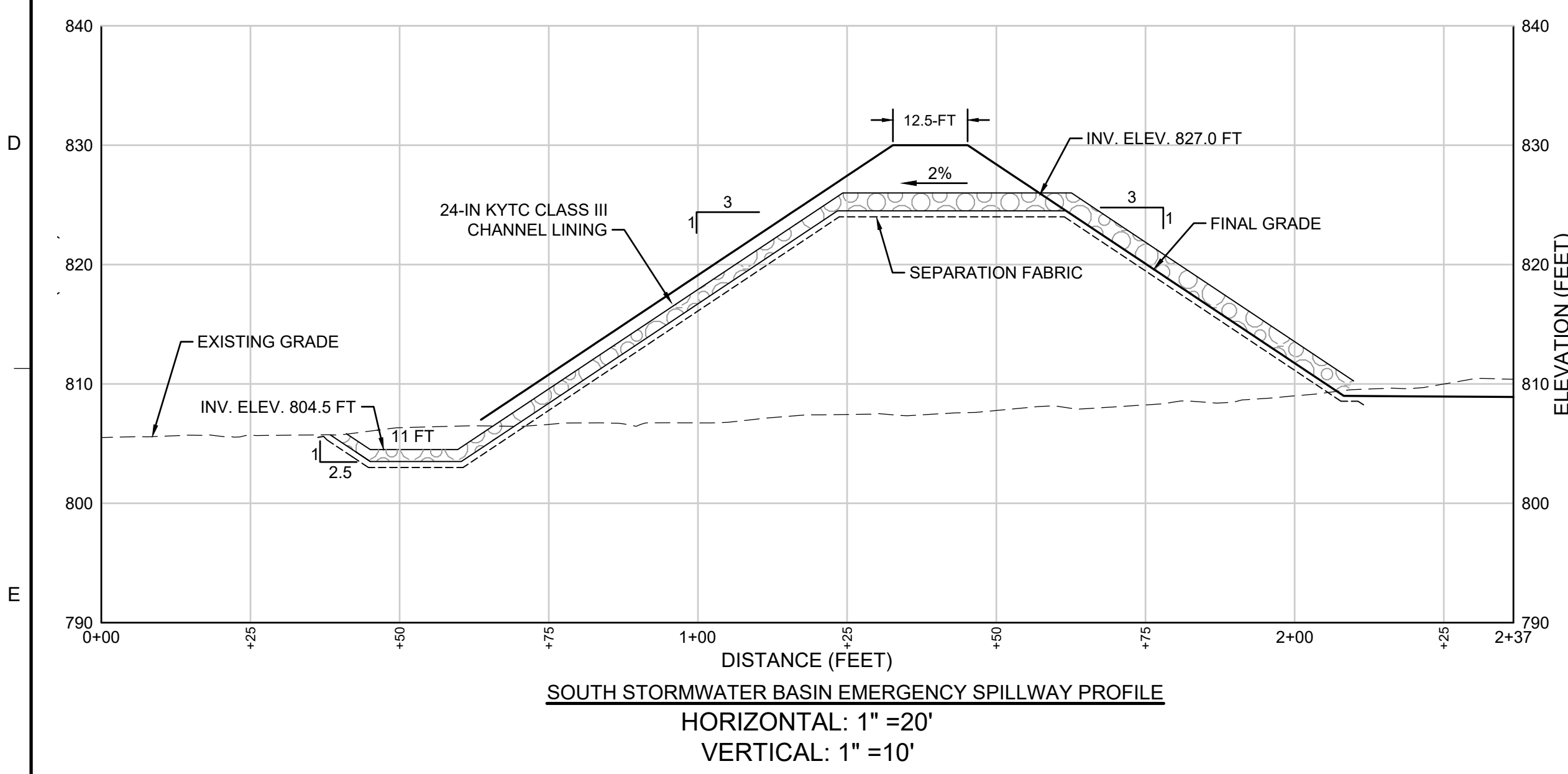

- NOTES:**
- SIDE SLOPES OF THE APRONS WILL BE 3H:1V WHERE NEEDED.
 - SEE TABLE 4 ON SHEET 22 FOR BOX CULVERT SIZING.



REV	DATE	DESCRIPTION	DRN	APP
 				
TITLE: SOUTH STORMWATER BASIN DESIGN PLAN VIEW, SECTIONS AND DETAILS				
PROJECT: EAST KENTUCKY POWER COOPERATIVE COOPER FORMER IMPOUNDMENT CLOSURE DESIGN				
SITE: COOPER POWER STATION, SOMERSET, KENTUCKY				
DESIGN BY: ZJF		DATE: MAY 2023		
DRAWN BY: MGK		PROJECT NO.: GPL8015		
CHECKED BY: TWW		FILE:		
REVIEWED BY: TWW		DRAWING NO.:		
APPROVED BY: JPS		8 OF 18		



LEGEND

	PROPERTY BOUNDARY
	EXISTING PERIMETER ROAD - CENTERLINE
	LIMITS OF CCB
	LIMIT OF DISTURBANCE
	PRECONSTRUCTION GROUND SURFACE ELEVATION (2- FT INTERVAL)
	PRECONSTRUCTION GROUND SURFACE ELEVATION (10- FT INTERVAL)
	CFI FINAL GRADING (2- FT INTERVAL)
	CFI FINAL GRADING (10- FT INTERVAL)
	EXISTING OVERHEAD ELECTRIC LINE
	EXISTING DITCH
	EXISTING CHAIN LINK FENCE
	EXISTING CULVERT
	EXISTING 48" DIA EFFLUENT SEWER LINE
	ABANDONED EXISTING 48" DIA EFFLUENT SEWER LINE
	EXISTING ELECTRIC POLE
	EXISTING ELECTRIC TRANSMISSION TOWER
	EXISTING LIGHT POLE

- NOTES:**
- PERIMETER ROAD IMPROVEMENTS SHALL CONSIST OF A 6-INCH CRUSHED STONE BASE WITH A WIDTH OF 10 FEET ALONG THE EXISTING PERIMETER ROAD.
 - THE PROPOSED SUBGRADE AS SHOWN IN THIS EXCAVATION PLAN ARE ASSUMED WITH 1 FOOT OVERDIG BELOW THE ANTICIPATED CCB BASE IN THE CONSOLIDATED AREAS. ELEVATIONS WERE DETERMINED USING THE PREDEVELOPMENT SITE TOPOGRAPHY IN THE 1978 AS-BUILT DRAWINGS OF ASH HANDLING FACILITIES BY STANLEY CONSULTANTS, AND THE 2021 SUBSURFACE EXPLORATION BY GEOSYNTEC.
 - VISIBLE CCB SHALL BE REMOVED, FINAL SUBGRADE SHALL BE VISIBLY INSPECTED BY A MEMBER OF THE CONSTRUCTION QUALITY ASSURANCE TEAM AFTER EXCAVATION. THE ACTUAL FINAL GRADES WILL BE DETERMINED IN THE FIELD DURING CCB REMOVAL CONSTRUCTION. VISIBLE CCB WITHIN KARST FEATURES WILL BE REMOVED TO THE EXTENT FEASIBLE FROM THE GROUND SURFACE ONSITE EQUIPMENT.
 - THE LATERAL LIMITS OF CCB WERE IDENTIFIED BASED ON THE PRE-DESIGN INVESTIGATION. IF CCB IS FOUND BEYOND THE LIMIT OF CCB, CCB SHALL BE EXCAVATED AND REMOVED FOR DISPOSAL.
 - IF THERE ARE LOCALIZED DEPRESSED AREAS WITHIN THE FOOTPRINT OF THE CFI AFTER EXCAVATION, THE AREAS SHALL BE GRADED SUCH THAT A MINIMUM 0.5 PERCENT SLOPE IS ACHIEVED.
 - CONTRACTOR SHALL MITIGATE ANY OBSERVED SWALLETS OR OTHER KARST FEATURES WITHIN THE LIMITS OF DISTURBANCE AS DIRECTED BY THE ENGINEER AND OWNER.

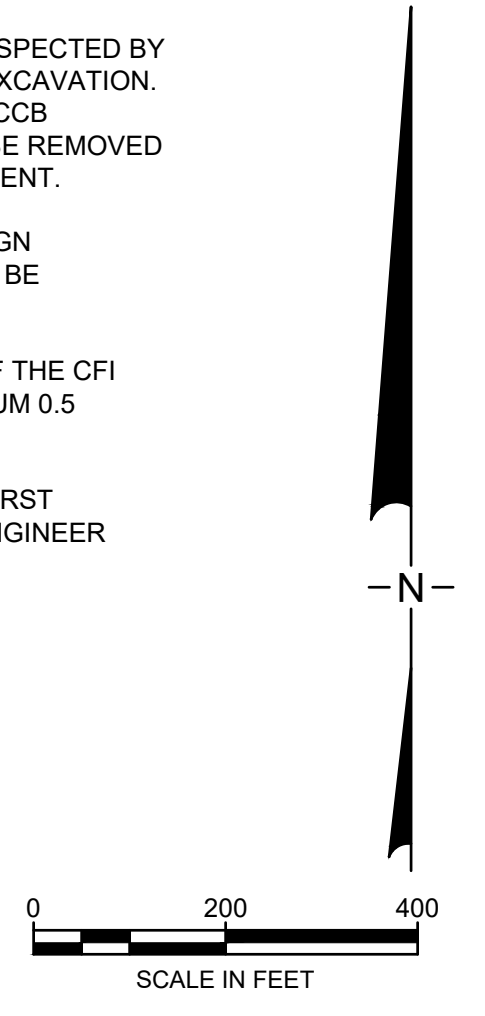

REV	DATE	DESCRIPTION	DRN	APP
<small>1 MCBRIDE AND SON CENTER DRIVE, # 202 CHESTERFIELD, MISSOURI 63005 TELEPHONE: 636-812-0800</small>		<small>4775 LEXINGTON RD., PO BOX 707 WINCHESTER, KY 40392</small>		
TITLE: EXCAVATION PLAN				
PROJECT: EAST KENTUCKY POWER COOPERATIVE COOPER FORMER IMPOUNDMENT CLOSURE DESIGN				
SITE: COOPER POWER STATION, SOMERSET, KENTUCKY				
DESIGN BY:	ZJF	DATE:	MAY 2023	
DRAWN BY:	TMM	PROJECT NO.:	GPL8015	
CHECKED BY:	TWW	FILE:		
REVIEWED BY:	TWW	DRAWING NO.:	10 OF 18	
APPROVED BY:	JPS			

90% DESIGN DRAWINGS - NOT FOR CONSTRUCTION

P:\KIP\1515-EMPC-COOPER FORMER IMPOUNDMENT CLOSURE DESIGN\1515-EMPC-010 EXCAVATION PLAN

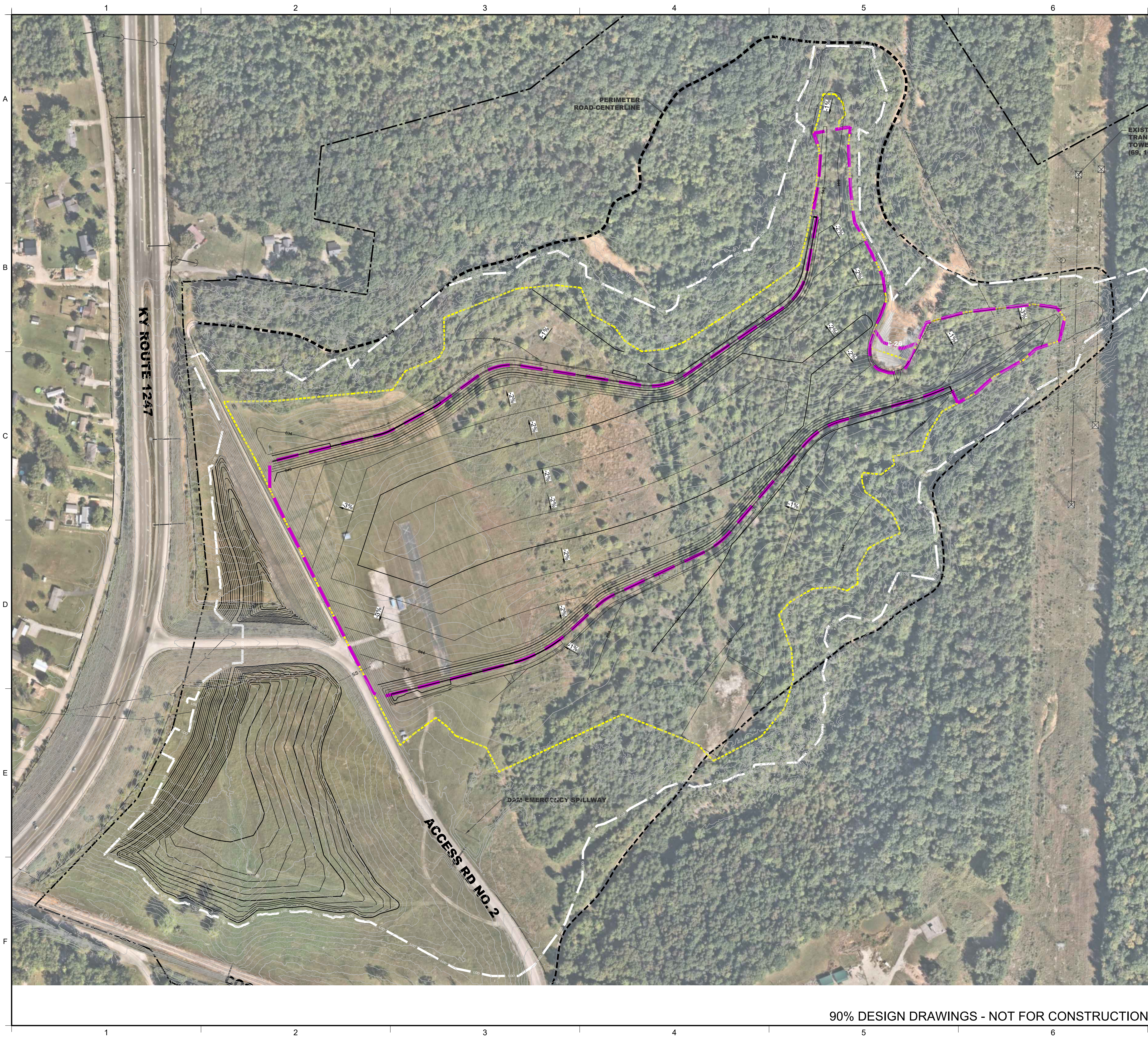

LEGEND

	PROPERTY BOUNDARY
	PROPOSED ANCHOR TRENCH
	EXISTING PERIMETER ROAD - CENTERLINE
	LIMITS OF CCB
	LIMIT OF DISTURBANCE
	PRECONSTRUCTION GROUND SURFACE ELEVATION (2- FT INTERVAL)
	PRECONSTRUCTION GROUND SURFACE ELEVATION (10- FT INTERVAL)
	CFI FINAL GRADING (2- FT INTERVAL)
	CFI FINAL GRADING (10- FT INTERVAL)
	EXISTING OVERHEAD ELECTRIC LINE
	EXISTING DITCH
	EXISTING CHAIN LINK FENCE
	EXISTING CULVERT
	EXISTING 48" DIA EFFLUENT SEWER LINE
	ABANDONED EXISTING 48" DIA EFFLUENT SEWER LINE
	EXISTING ELECTRIC POLE
	EXISTING ELECTRIC TRANSMISSION TOWER
	EXISTING LIGHT POLE

NOTES:

- FOLLOWING THE COMPLETION OF THE SUBGRADE, STORMWATER FLOW WILL TEMPORARILY POND ON THE CAP AND SURROUNDING AREAS PRIOR TO BEING PUMPED TO THE STORMWATER BASINS.

0 200 400
SCALE IN FEET

REV	DATE	DESCRIPTION	DRN	APP
1 MCBRIDE AND SON CENTER DRIVE, # 202 CHESTERFIELD, MISSOURI 63005 TELEPHONE: 636-812-0800		4775 LEXINGTON RD., PO BOX 707 WINCHESTER, KY 40392		
TITLE: GEOMEMBRANE SUBGRADE PLAN				
PROJECT: EAST KENTUCKY POWER COOPERATIVE COOPER FORMER IMPOUNDMENT CLOSURE DESIGN				
SITE: COOPER POWER STATION, SOMERSET, KENTUCKY				
DESIGN BY: ZJF		DATE: MAY 2023		
DRAWN BY: TMM		PROJECT NO.: GPL8015		
CHECKED BY: TWW		FILE:		
REVIEWED BY: TWW		DRAWING NO.:		
APPROVED BY: JPS		<div style="display: flex; justify-content: space-between;"> 11 OF 18 </div>		

90% DESIGN DRAWINGS - NOT FOR CONSTRUCTION

P:\KIP\1515-EMPC-COOPER FORMER IMPOUNDMENT CLOSURE DESIGN\1515-11-01 SUBGRADE PLAN

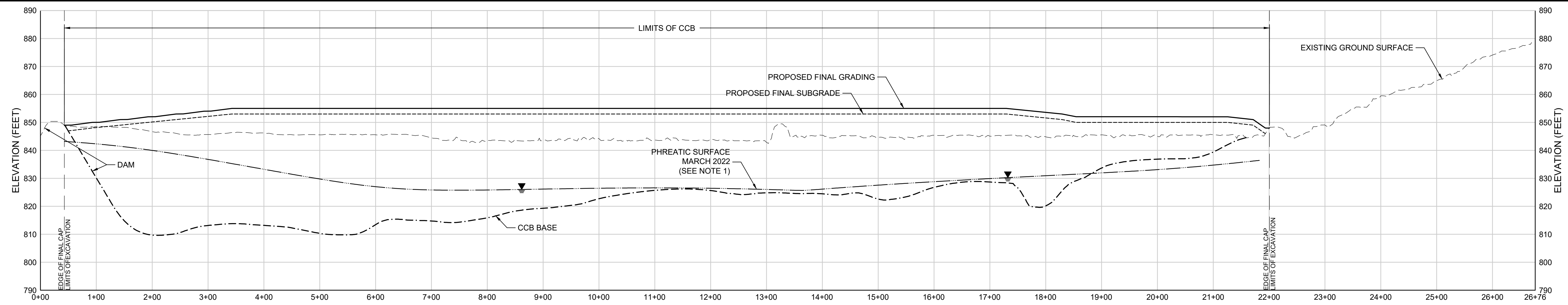

PROFILE A-A
CCB CAPPED AREA
HORIZONTAL: 1" = 20'
VERTICAL: 1" = 4'

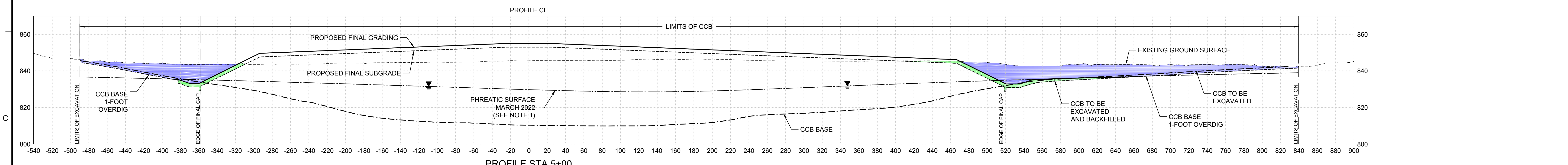

PROFILE STA 5+00

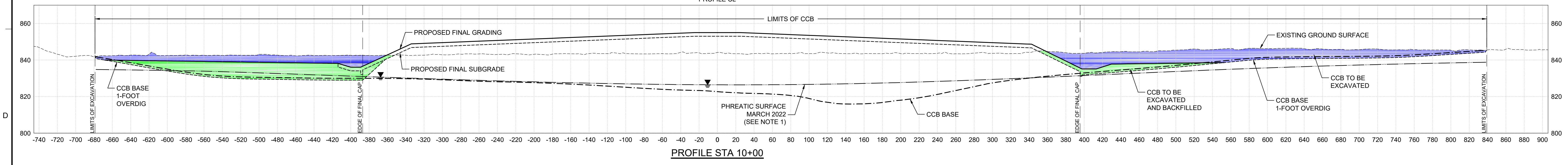

PROFILE STA 10+00

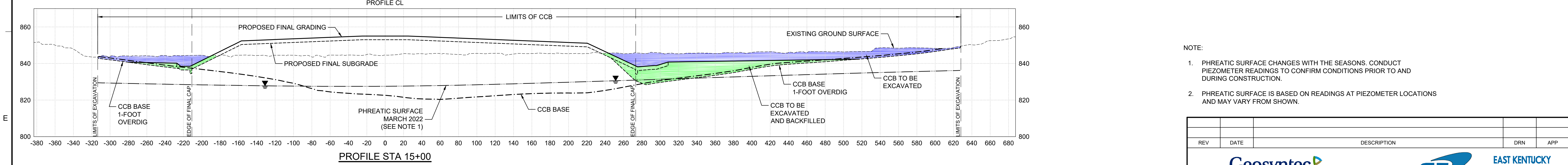

PROFILE STA 15+00

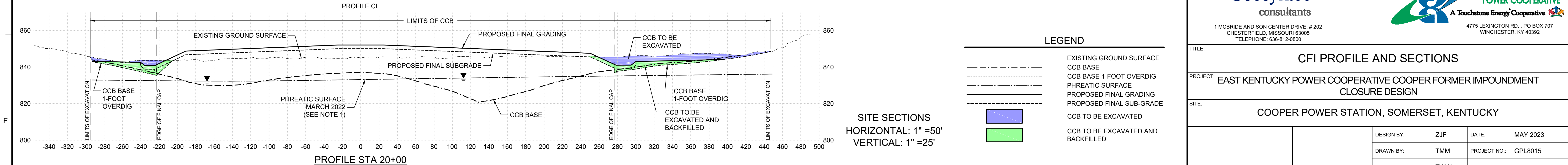

PROFILE STA 20+00

LEGEND

	EXISTING GROUND SURFACE
	CCB BASE
	CCB BASE 1-FOOT OVERDIG
	PHREATIC SURFACE
	PROPOSED FINAL GRADING
	PROPOSED FINAL SUB-GRADE
	CCB TO BE EXCAVATED
	CCB TO BE EXCAVATED AND BACKFILLED

SITE SECTIONS
HORIZONTAL: 1" = 50'
VERTICAL: 1" = 25'

- NOTE:**
- PHREATIC SURFACE CHANGES WITH THE SEASONS. CONDUCT PIEZOMETER READINGS TO CONFIRM CONDITIONS PRIOR TO AND DURING CONSTRUCTION.
 - PHREATIC SURFACE IS BASED ON READINGS AT PIEZOMETER LOCATIONS AND MAY VARY FROM SHOWN.

REV	DATE	DESCRIPTION	DRN	APP

1 MCBRIDE AND SON CENTER DRIVE, # 202
CHESTERFIELD, MISSOURI 63005
TELEPHONE: 636-812-0800

4775 LEXINGTON RD., PO BOX 707
WINCHESTER, KY 40392

TITLE: CFI PROFILE AND SECTIONS

PROJECT: EAST KENTUCKY POWER COOPERATIVE COOPER FORMER IMPOUNDMENT CLOSURE DESIGN

SITE: COOPER POWER STATION, SOMERSET, KENTUCKY

DESIGN BY: ZJF	DATE: MAY 2023
DRAWN BY: TMM	PROJECT NO.: GPL8015
CHECKED BY: TWW	FILE:
REVIEWED BY: TWW	DRAWING NO.:
APPROVED BY: JPS	13 OF 18

90% DESIGN DRAWINGS - NOT FOR CONSTRUCTION

P:\KIPRIS\BPC\COOPER\CONTRACTOR WORKING DRAWINGS\DWG150131.CFI CROSS PROFILES

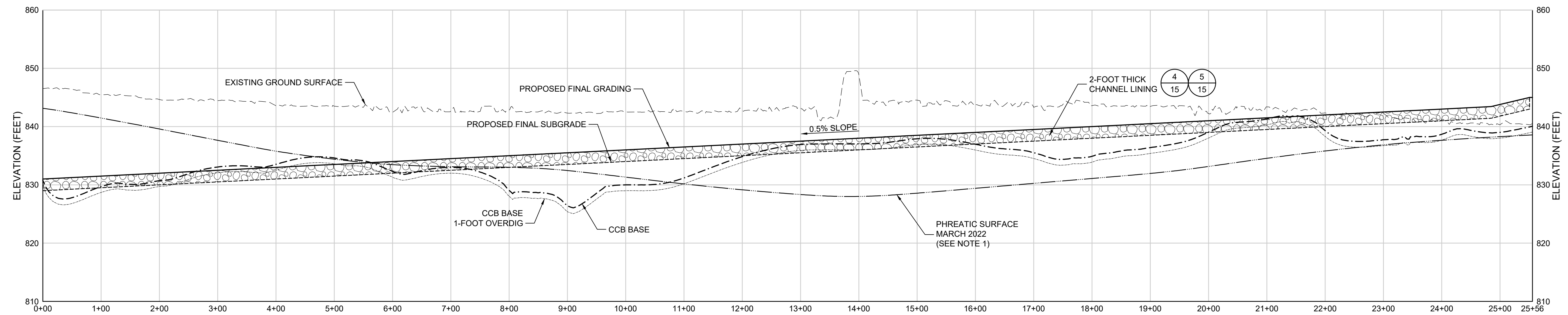

PROFILE B-B
NORTH DRAINAGE CHANNEL
HORIZONTAL: 1" = 100'
VERTICAL: 1" = 10'

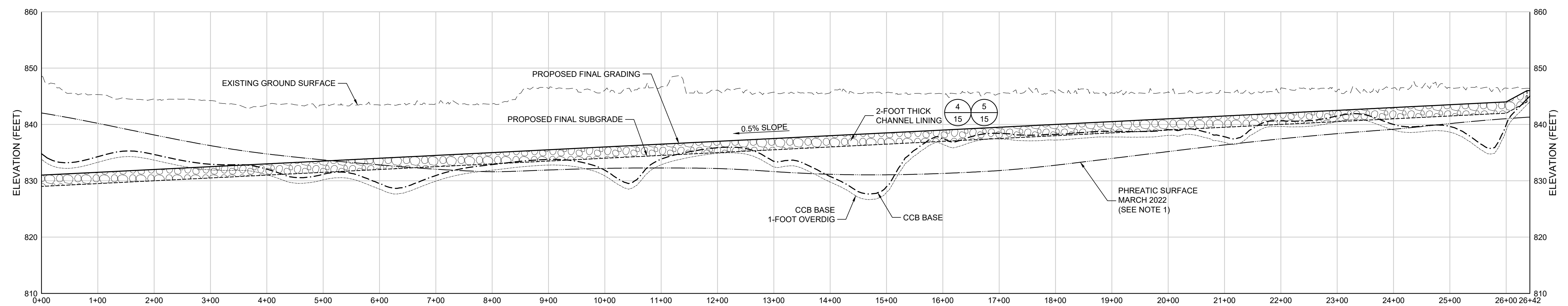

PROFILE C-C
SOUTH DRAINAGE CHANNEL
HORIZONTAL: 1" = 100'
VERTICAL: 1" = 10'

NOTE:
1. PHREATIC SURFACE CHANGES WITH THE SEASONS. CONDUCT PIEZOMETER READINGS TO CONFIRM CONDITIONS PRIOR TO AND DURING CONSTRUCTION.

LEGEND

-----	EXISTING GROUND SURFACE
-----	CCB BASE
-----	CCB BASE 1-FOOT OVERDIG
-----	PHREATIC SURFACE
-----	PROPOSED FINAL GRADING
-----	PROPOSED FINAL SUB-GRADE
	2-FOOT THICK CHANNEL LINING

90% DESIGN DRAWINGS - NOT FOR CONSTRUCTION

REV	DATE	DESCRIPTION	DRN	APP
<p>1 MCBRIDE AND SON CENTER DRIVE, # 202 CHESTERFIELD, MISSOURI 63005 TELEPHONE: 636-812-0800</p> <p>4775 LEXINGTON RD., PO BOX 707 WINCHESTER, KY 40392</p>				
<p>TITLE: NORTH AND SOUTH DRAINAGE CHANNEL PROFILES</p>				
<p>PROJECT: EAST KENTUCKY POWER COOPERATIVE COOPER FORMER IMPOUNDMENT CLOSURE DESIGN</p>				
<p>SITE: COOPER POWER STATION, SOMERSET, KENTUCKY</p>				
DESIGN BY: ZJF		DATE: MAY 2023		
DRAWN BY: TMM		PROJECT NO.: GPL8015		
CHECKED BY: TWW		FILE:		
REVIEWED BY: TWW		DRAWING NO.:		
APPROVED BY: JPS		<p>14 OF 18</p>		

P:\KIPR15\BPC\COOPER\LEGACY FOND\CONTRACTOR WORKING DRAWINGS\DWG15-014-CFI DRAINAGE CHANNEL PROFILES

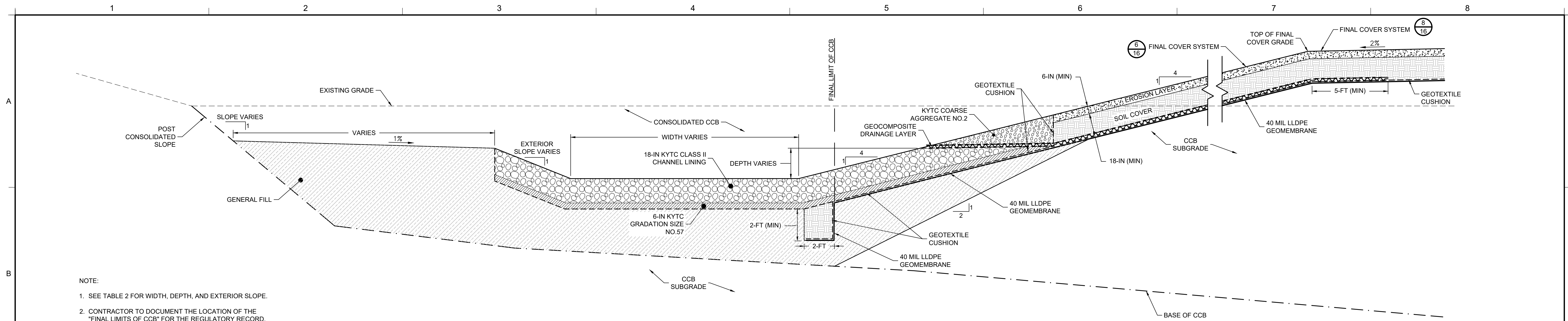

NOTE:
 1. SEE TABLE 2 FOR WIDTH, DEPTH, AND EXTERIOR SLOPE.
 2. CONTRACTOR TO DOCUMENT THE LOCATION OF THE "FINAL LIMITS OF CCB" FOR THE REGULATORY RECORD.

4 DETAIL
15 PERIMETER DITCH COVER SYSTEM TIE-IN
 N.T.S.

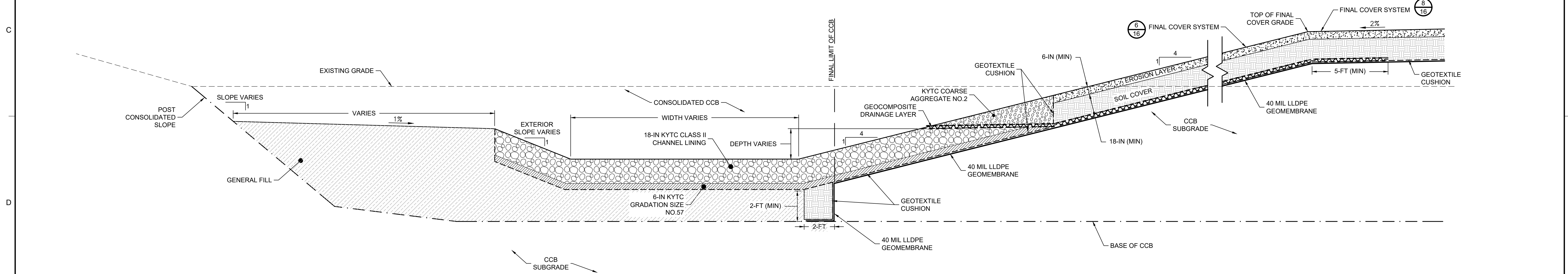



NOTE:
 1. SEE TABLE 2 FOR WIDTH, DEPTH, AND EXTERIOR SLOPE.
 2. CONTRACTOR TO DOCUMENT THE LOCATION OF THE "FINAL LIMITS OF CCB" FOR THE REGULATORY RECORD.

5 DETAIL
15 PERIMETER DITCH EXTENDED COVER SYSTEM TIE-IN
 N.T.S.

TABLE 3

TYPE	DITCH	STARTING STATION	ENDING STATION	WIDTH (FT)	DEPTH (FT)	EXTERIOR SLOPE
A	NORTH	0+00.00	12+20.00	10	2	6H:1V
B	NORTH	12+20.00	13+00.00	10	TRANSITION	
C	NORTH	13+00.00	24+84.61	10	1.7	2.5H:1V
D	SOUTH	0+00.00	15+10.00	15	2.6	6H:1V
E	SOUTH	15+10.00	16+50.00	15	TRANSITION	
F	SOUTH	16+50.00	26+00.00	15	1.9	2.5H:1V

90% DESIGN DRAWINGS - NOT FOR CONSTRUCTION

REV	DATE	DESCRIPTION	DRN	APP
 				
<p>1 MCBRIDE AND SON CENTER DRIVE, # 202 CHESTERFIELD, MISSOURI 63005 TELEPHONE: 636-812-0800</p> <p>4775 LEXINGTON RD., PO BOX 707 WINCHESTER, KY 40392</p>				
DETAILS 1 OF 2				
PROJECT: EAST KENTUCKY POWER COOPERATIVE COOPER FORMER IMPOUNDMENT CLOSURE DESIGN				
SITE: COOPER POWER STATION, SOMERSET, KENTUCKY				
DESIGN BY: ZJF		DATE: MAY 2023		
DRAWN BY: TMM		PROJECT NO.: GPL8015		
CHECKED BY: TWW		FILE:		
REVIEWED BY: TWW		DRAWING NO.:		
APPROVED BY: JPS		15 OF 18		

P:\KIP\1515-EPIC-COOPER-LEGACY-POND-CONTRACTOR-WORKING-DRAWINGS\1515-DETAILS 1 OF 2

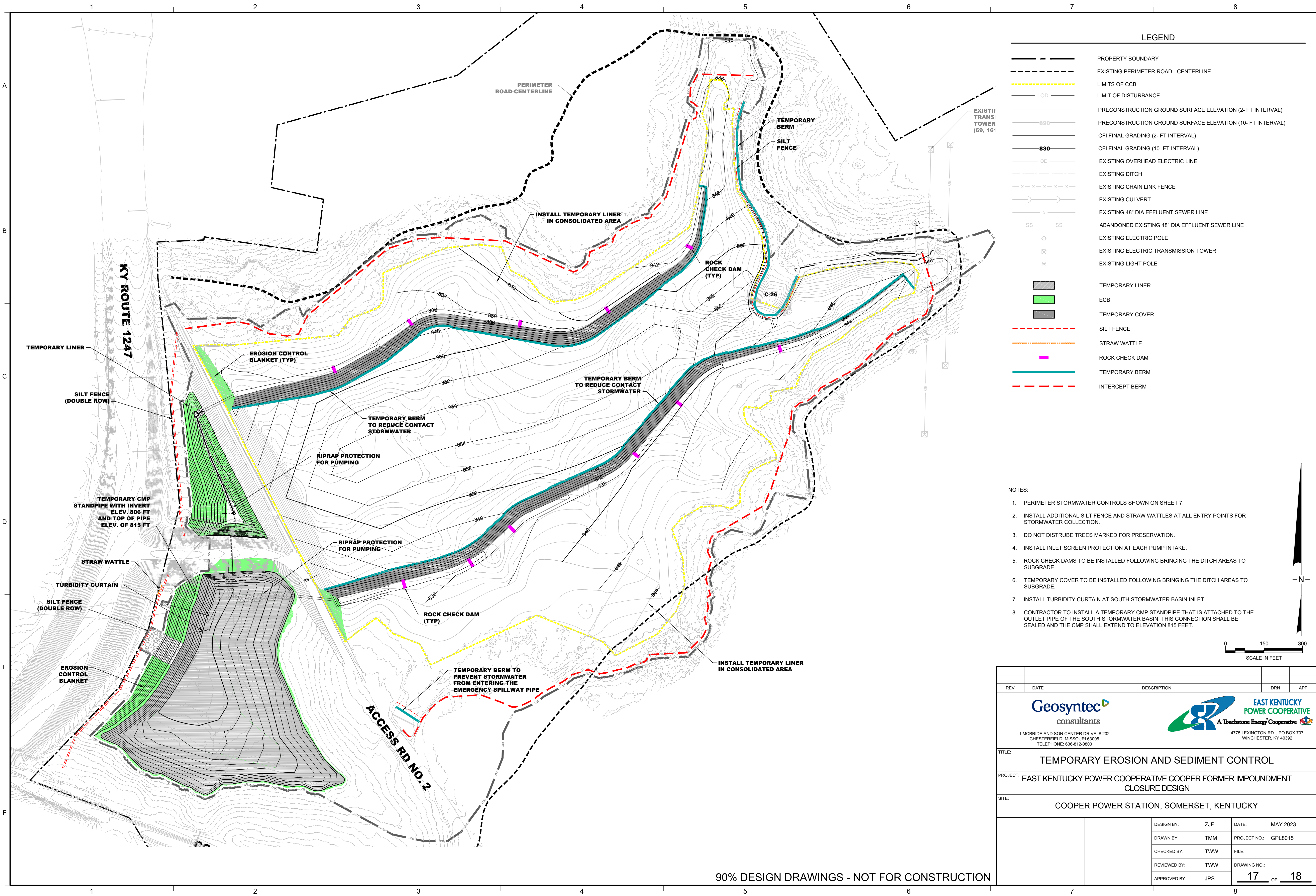

LEGEND

	PROPERTY BOUNDARY
	EXISTING PERIMETER ROAD - CENTERLINE
	LIMITS OF CCB
	LIMIT OF DISTURBANCE
	PRECONSTRUCTION GROUND SURFACE ELEVATION (2- FT INTERVAL)
	PRECONSTRUCTION GROUND SURFACE ELEVATION (10- FT INTERVAL)
	CFI FINAL GRADING (2- FT INTERVAL)
	CFI FINAL GRADING (10- FT INTERVAL)
	EXISTING OVERHEAD ELECTRIC LINE
	EXISTING DITCH
	EXISTING CHAIN LINK FENCE
	EXISTING CULVERT
	EXISTING 48" DIA EFFLUENT SEWER LINE
	ABANDONED EXISTING 48" DIA EFFLUENT SEWER LINE
	EXISTING ELECTRIC POLE
	EXISTING ELECTRIC TRANSMISSION TOWER
	EXISTING LIGHT POLE
	TEMPORARY LINER
	ECB
	TEMPORARY COVER
	SILT FENCE
	STRAW WATTLE
	ROCK CHECK DAM
	TEMPORARY BERM
	INTERCEPT BERM

- NOTES:
1. PERIMETER STORMWATER CONTROLS SHOWN ON SHEET 7.
 2. INSTALL ADDITIONAL SILT FENCE AND STRAW WATTLES AT ALL ENTRY POINTS FOR STORMWATER COLLECTION.
 3. DO NOT DISTURBE TREES MARKED FOR PRESERVATION.
 4. INSTALL INLET SCREEN PROTECTION AT EACH PUMP INTAKE.
 5. ROCK CHECK DAMS TO BE INSTALLED FOLLOWING BRINGING THE DITCH AREAS TO SUBGRADE.
 6. TEMPORARY COVER TO BE INSTALLED FOLLOWING BRINGING THE DITCH AREAS TO SUBGRADE.
 7. INSTALL TURBIDITY CURTAIN AT SOUTH STORMWATER BASIN INLET.
 8. CONTRACTOR TO INSTALL A TEMPORARY CMP STANDPIPE THAT IS ATTACHED TO THE OUTLET PIPE OF THE SOUTH STORMWATER BASIN. THIS CONNECTION SHALL BE SEALED AND THE CMP SHALL EXTEND TO ELEVATION 815 FEET.
- SCALE IN FEET
0 150 300

REV	DATE	DESCRIPTION	DRN	APP
1 MCBRIDE AND SON CENTER DRIVE, # 202 CHESTERFIELD, MISSOURI 63005 TELEPHONE: 636-812-0800		4775 LEXINGTON RD., PO BOX 707 WINCHESTER, KY 40392		
TITLE: TEMPORARY EROSION AND SEDIMENT CONTROL				
PROJECT: EAST KENTUCKY POWER COOPERATIVE COOPER FORMER IMPOUNDMENT CLOSURE DESIGN				
SITE: COOPER POWER STATION, SOMERSET, KENTUCKY				
		DESIGN BY: ZJF	DATE: MAY 2023	
		DRAWN BY: TMM	PROJECT NO.: GPL8015	
		CHECKED BY: TWW	FILE:	
		REVIEWED BY: TWW	DRAWING NO.:	
		APPROVED BY: JPS	17 OF 18	

90% DESIGN DRAWINGS - NOT FOR CONSTRUCTION

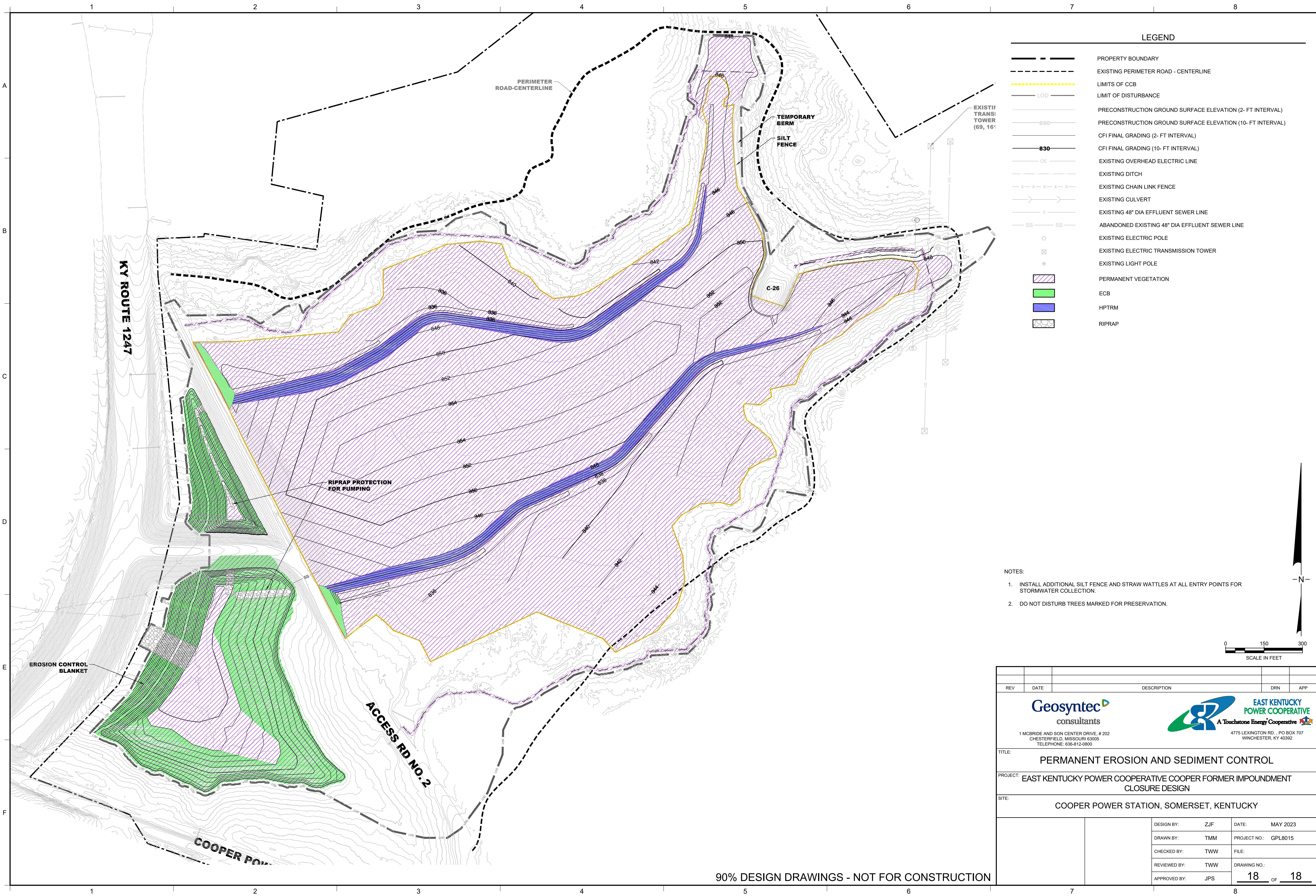

LEGEND

- PROPERTY BOUNDARY
- EXISTING PERIMETER ROAD - CENTERLINE
- LIMITS OF CCB
- LIMIT OF DISTURBANCE
- PRECONSTRUCTION GROUND SURFACE ELEVATION (2- FT INTERVAL)
- PRECONSTRUCTION GROUND SURFACE ELEVATION (10- FT INTERVAL)
- CFI FINAL GRADING (2- FT INTERVAL)
- CFI FINAL GRADING (10- FT INTERVAL)
- EXISTING OVERHEAD ELECTRIC LINE
- EXISTING DITCH
- EXISTING CHAIN LINK FENCE
- EXISTING CULVERT
- EXISTING 48" DIA EFFLUENT SEWER LINE
- ABANDONED EXISTING 48" DIA EFFLUENT SEWER LINE
- EXISTING ELECTRIC POLE
- EXISTING ELECTRIC TRANSMISSION TOWER
- EXISTING LIGHT POLE
- PERMANENT VEGETATION
- ECB
- HPTRM
- RIPRAP

NOTES:

1. INSTALL ADDITIONAL SILT FENCE AND STRAW WATTLES AT ALL ENTRY POINTS FOR STORMWATER COLLECTION.
2. DO NOT DISTURB TREES MARKED FOR PRESERVATION.

N
 0 150 300
 SCALE IN FEET

REV	DATE	DESCRIPTION	DRN	APP
1 MCBRIDE AND SON CENTER DRIVE, # 202 CHESTERFIELD, MISSOURI 63005 TELEPHONE: 636-812-0800		4775 LEXINGTON RD., PO BOX 707 WINCHESTER, KY 40392		
TITLE: PERMANENT EROSION AND SEDIMENT CONTROL				
PROJECT: EAST KENTUCKY POWER COOPERATIVE COOPER FORMER IMPOUNDMENT CLOSURE DESIGN				
SITE: COOPER POWER STATION, SOMERSET, KENTUCKY				
DESIGN BY:	ZJF	DATE:	MAY 2023	
DRAWN BY:	TMM	PROJECT NO.:	GPL8015	
CHECKED BY:	TWW	FILE:		
REVIEWED BY:	TWW	DRAWING NO.:	18 OF 18	
APPROVED BY:	JPS			

90% DESIGN DRAWINGS - NOT FOR CONSTRUCTION

P:\KIPR15\BPC-COOPER FORMER IMPOUNDMENT CLOSURE DESIGN\DWG\15018 PERMANENT EROSION AND SEDIMENT CONTROL

APPENDIX D CONSTRUCTION SCHEDULE

Activity ID	Activity Name	Activity % Complete	Planned Duration	Start	Finish
EKPC-GLP8015-1 Cooper Former Impoundment Closure		990		01-Feb-23	23-Dec-26
EKPC-GLP8015-1.1 CFI Closure		990		01-Feb-23	23-Dec-26
1.01	Project Board Approval	0%	0	31-Mar-23*	
1.02	CPCN Application Preparation	0%	85	01-Feb-23*	31-May-23
1.03	Submit CPCN	0%	127	01-Jun-23	30-Nov-23
1.04	PSC CPCN Order Granted	0%	20	01-Dec-23	29-Dec-23
1.05	Detailed Engineering and Design	0%	232	31-Mar-23	28-Feb-24
1.07	KPDES Final Water Permit	0%	0		29-Sep-23*
1.08	KDOW Dam Permit Development	0%	82	01-Sep-23	29-Dec-23
1.09	KDOW Dam Permit Submittal and Review	0%	234	02-Jan-24	27-Nov-24
1.12	KYTC Permit	0%	64	02-Jan-24	29-Mar-24
1.13	Contract Development	0%	22	01-Apr-24	30-Apr-24
1.14	Contract Procurement	0%	42	01-May-24	28-Jun-24
1.15	Bid Evaluation	0%	44	01-Jul-24	30-Aug-24
1.16	Contract Board Approval	0%	43	03-Sep-24	31-Oct-24
1.17	Contract Award	0%	19	01-Nov-24	27-Nov-24
2.01	Mobilization	0%	10	01-Apr-25*	14-Apr-25
2.02	Erosion and Sediment Controls	0%	10	15-Apr-25	28-Apr-25
2.03	Stormwater Basins	0%	50	15-Apr-25	24-Jun-25
2.04	Temporary Stormwater Management Facilities	0%	50	15-Apr-25	24-Jun-25
2.05	Dewatering Trench Excavation & Construction Dewatering	0%	350	25-Jun-25	09-Nov-26
2.06	Site Clearing	0%	50	15-Apr-25	24-Jun-25
2.07	Consolidate CCB within CFI	0%	95	30-Apr-26	14-Sep-26
2.08	General Fill Placement	0%	40	15-Sep-26	09-Nov-26
2.09	Perimeter Ditches	0%	115	29-May-26	09-Nov-26
2.10	Geosynthetic Cap System	0%	115	29-May-26	09-Nov-26
2.11	C-26 Mitigation	0%	10	10-Nov-26	23-Nov-26
2.12	Turf and Grasses	0%	10	10-Nov-26	23-Nov-26
2.13	Instrumentation	0%	360	15-Apr-25	14-Sep-26
2.14	Demolition	0%	20	15-Apr-25	12-May-25
2.20	Weather Delay Contingency	0%	20	24-Nov-26	23-Dec-26

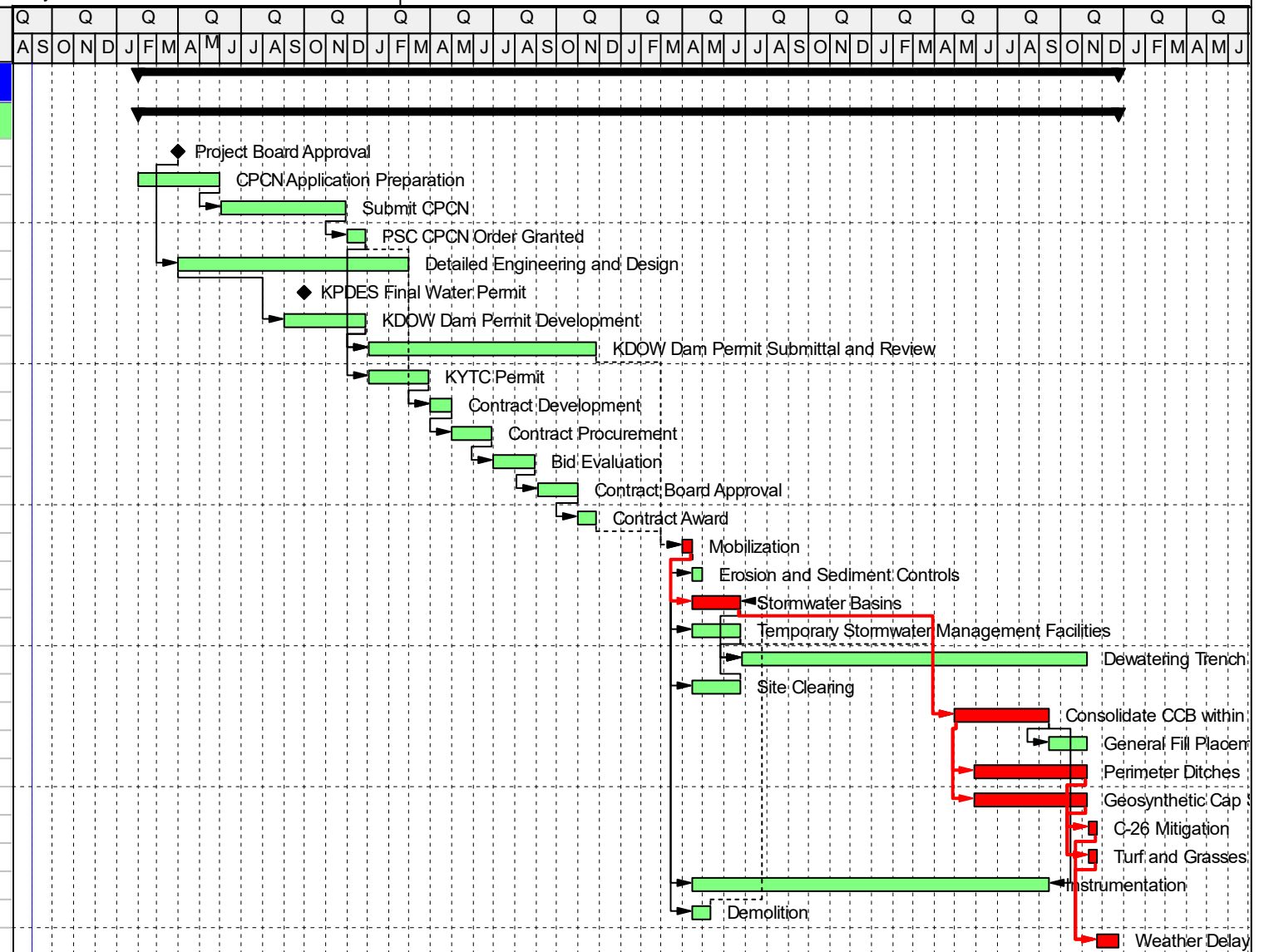

█ Actual Level of Effort
 █ Remaining Work
 █ Actual Work
 █ Critical Remaining Work
 ◆ Milestone
 ── summary

APPENDIX E CAPITAL AND O&M COST ESTIMATE / PROJECT CASH FLOW CHART

Facility: Cooper Former Impoundment
Client: EKPC
Project: Project Scoping Report
Project No.: GLP8015
Date: June 14, 2023

CFI Closure - Cost Summary

		Base Cost	Contingency (15%)	Estimated Construction Cost	Owners Contingency (10%)	Inflation Costs	Adjusted Capital Costs Total	Estimated Annual Long-Term Maintenance Costs	Construction Schedule (MO)
Closure Items		\$34,400,000	\$4,700,000	\$39,100,000	\$3,900,000	\$4,200,000	\$47,200,000	\$65,000	21
0	Preconstruction / Engineering / Maintenance Tasks	\$5,482,000	\$336,000	\$5,818,000					-
1	Mobilization / Demobilization	\$1,112,000	\$166,000	\$1,278,000					0.5
2	Erosion and Sediment Controls	\$1,996,000	\$300,000	\$2,296,000					0.5
3	Stormwater Basins	\$2,004,000	\$303,000	\$2,307,000					2.5
4	Temporary Stormwater Management Features	\$1,277,000	\$191,000	\$1,468,000					2.5
5	Dewatering	\$5,410,000	\$811,000	\$6,221,000					17.0
6	Site Clearing	\$1,020,000	\$153,000	\$1,173,000					2.5
7	Manage CCB	\$4,000,000	\$602,000	\$4,602,000					4.5
8	General Fill Placement For Positive Drainage	\$2,311,000	\$346,000	\$2,657,000					2.0
9	Perimeter Ditches	\$2,572,000	\$386,000	\$2,958,000					5.5
10	Geosynthetic Cap System	\$6,376,000	\$958,000	\$7,334,000					5.5
11	C-26 Mitigation	\$134,000	\$21,000	\$155,000					0.5
12	Turf and Grasses for Final Cover System	\$432,000	\$65,000	\$497,000					0.5
13	Instrumentation	\$70,000	\$11,000	\$81,000					19.5
14	Demolition	\$208,000	\$31,000	\$239,000					1.0
15	Post-Closure Cost Estimate							\$65,000	-

CFI Closure - Construction Project Cash Flow

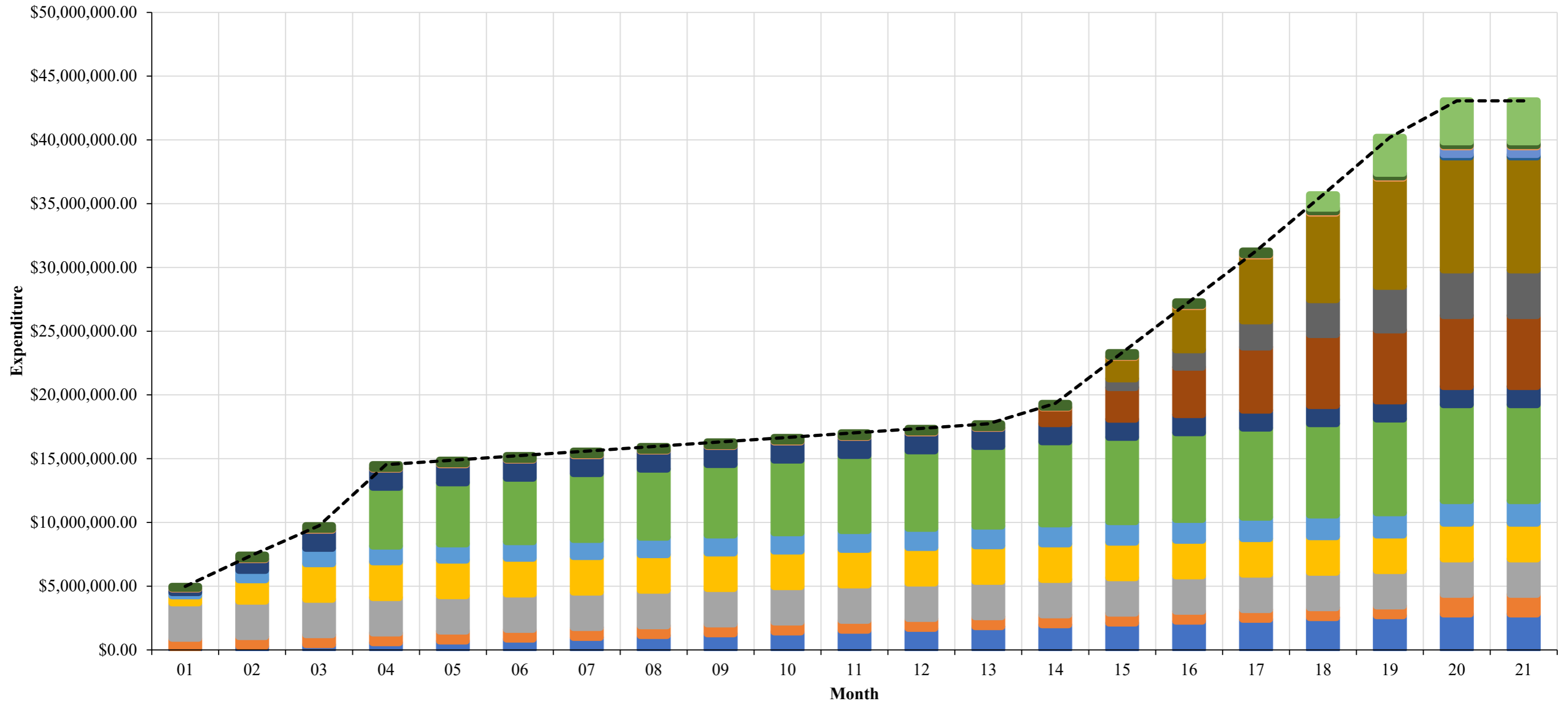

- Preconstruction / Engineering / Maintenance Tasks
- Stormwater Basins
- Site Clearing
- Geosynthetic Cap System
- Instrumentation
- Mobilization / Demobilization
- Temporary Stormwater Management Features
- Manage CCB
- C-26 Mitigation
- Demolition
- Erosion and Sediment Controls
- Dewatering
- Perimeter Ditches
- Turf and Grasses for Final Cover System
- General Fill Placement For Positive Drainage
- Total Expenditures

CFI Closure - Construction Project Cash Flow - Monthly

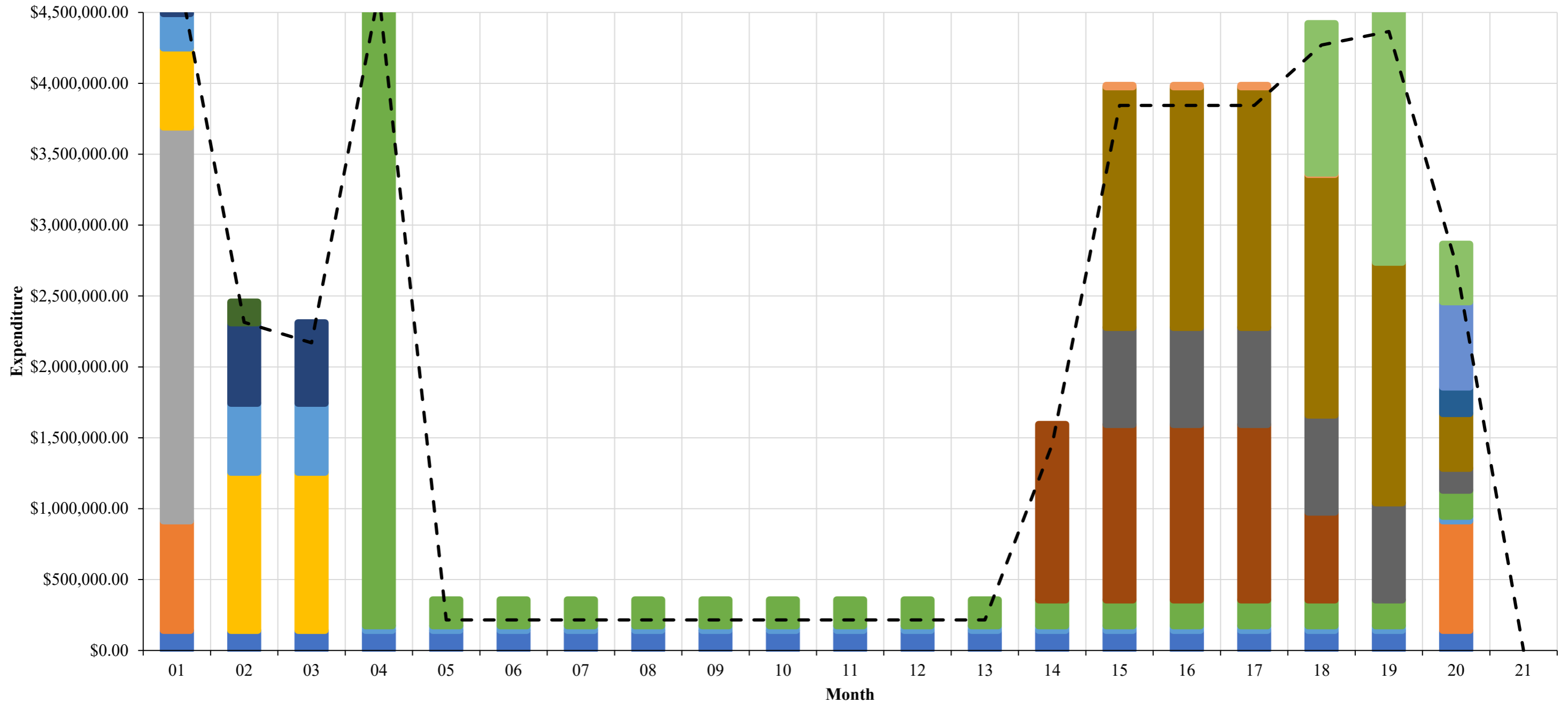

- Preconstruction / Engineering / Maintenance Tasks
- Stormwater Basins
- Site Clearing
- Geosynthetic Cap System
- Instrumentation
- Total Expenditures
- Mobilization / Demobilization
- Temporary Stormwater Management Features
- Manage CCB
- C-26 Mitigation
- Demolition
- Erosion and Sediment Controls
- Dewatering
- Perimeter Ditches
- Turf and Grasses for Final Cover System
- General Fill Placement For Positive Drainage

EXHIBIT

J

COMMONWEALTH OF KENTUCKY
BEFORE THE PUBLIC SERVICE COMMISSION

IN THE MATTER OF:

ELECTRONIC APPLICATION OF EAST)	
KENTUCKY POWER COOPERATIVE, INC. FOR)	
APPROVAL TO AMEND ITS ENVIRONMENTAL)	
COMPLIANCE PLAN AND RECOVER COSTS)	CASE NO.
PURSUANT TO ITS ENVIRONMENTAL)	2023-00177
SURCHARGE, AND FOR THE ISSUANCE OF)	
CERTIFICATES OF PUBLIC CONVENIENCE)	
AND NECESSITY AND OTHER RELIEF)	

DIRECT TESTIMONY OF ISAAC S. SCOTT
ON BEHALF OF EAST KENTUCKY POWER COOPERATIVE, INC.

Filed: June 30, 2023

1 **I. INTRODUCTION**

2 **Q. PLEASE STATE YOUR NAME, BUSINESS ADDRESS, AND OCCUPATION.**

3 A. My name is Isaac S. Scott and I am the Pricing Manager for East Kentucky Power
4 Cooperative, Inc. ("EKPC"). My business address is 4775 Lexington Road, Winchester,
5 Kentucky 40391.

6 **Q. PLEASE STATE YOUR EDUCATION AND PROFESSIONAL EXPERIENCE.**

7 A. I received a B.S. degree in Accounting, with distinction, from the University of Kentucky
8 in 1979. After graduation I was employed by the Kentucky Auditor of Public Accounts,
9 where I performed audits of numerous state agencies. In December 1985, I transferred to
10 the Kentucky Public Service Commission ("Commission") as a public utilities financial
11 analyst, concentrating on the electric and natural gas industries. In August 2001, I became
12 manager of the Electric and Gas Revenue Requirements Branch in the Division of Financial
13 Analysis at the Commission. In this position, I supervised the preparation of revenue
14 requirement determinations for electric and natural gas utilities as well as determined the
15 revenue requirements for the major electric and natural gas utilities in Kentucky. I retired
16 from the Commission effective August 1, 2008. In November 2008, I became the Pricing
17 Manager at EKPC.

18 **Q. PLEASE PROVIDE A BRIEF DESCRIPTION OF YOUR DUTIES AT EKPC.**

19 A. As Pricing Manager, I am responsible for rate-making activities which include designing
20 and developing wholesale and retail electric rates and developing pricing concepts and
21 methodologies. I report directly to the Director of Regulatory and Compliance Services.

22 **Q. HAVE YOU PREVIOUSLY TESTIFIED BEFORE THE COMMISSION? IF SO,
23 WHAT CASES?**

1 A. I have testified before the Commission in numerous cases. I testified in EKPC's last two
2 base rate cases (Case Nos. 2010-00167 and 2021-00103), the Cooper ductwork reroute
3 case (Case No. 2013-00259), and three fuel adjustment clause two-year review cases (Case
4 Nos. 2017-00002, 2019-00003, and 2021-00054). I have also submitted written direct
5 testimony in every environmental surcharge review case since 2012, the last three
6 environmental surcharge compliance plan amendment cases, EKPC's application for an
7 economic development rider tariff, and administrative cases dealing with the consideration
8 of the Energy Independence and Security Act of 2007 and the implementation of smart
9 grid and smart meter technologies.

10 **Q. WHAT IS THE PURPOSE OF YOUR TESTIMONY IN THIS PROCEEDING?**

11 A. The purpose of my testimony is to describe the cost of constructing a series of
12 improvements to the Hugh L. Spurlock Generation Station ("Spurlock Station") and the
13 John S. Cooper Station ("Cooper Station") (collectively the "2023 plan projects") that will
14 enable EKPC to comply with applicable environmental statutes and regulations. In
15 addition, I will discuss how EKPC's Environmental Compliance Plan will be implemented
16 on a monthly basis and the rate impact at the wholesale and retail levels. I will also discuss
17 the determination of a Base Environmental Surcharge Factor ("BESF") associated with
18 compliance plan projects partially recovered through existing base rates and EKPC's
19 proposed tariff revision recognizing the BESF. Finally, I will describe the proposed
20 revisions to EKPC's monthly environmental surcharge reporting forms.

21 **II. SPONSORED EXHIBITS**

22 **Q. ARE YOU SPONSORING ANY EXHIBITS?**

23 A. Yes. I am sponsoring the following exhibits, which I ask be incorporated into my testimony
24 by reference:

- 1 • Exhibit ISS-1: A schedule showing the current Environmental Compliance Plan
2 and the addition of the 2023 plan projects proposed in this Application.
- 3 • Exhibit ISS-2: A sample copy of the monthly environmental surcharge reporting
4 formats which reflect the inclusion of the 2023 plan projects. See *Excel filename*
5 *“Exhibit ISS-2 – Reporting Formats CLEAN.xlsx”* and *“Exhibit ISS-2 – Reporting*
6 *Formats REDLINED.xlsx”*.
- 7 • Exhibit ISS-3: A schedule showing the determination of the BESF reflecting those
8 2023 plan projects partially being recovered through existing base rates. See *Excel*
9 *filename “Exhibit ISS-3 – BESF Calculation.xlsx”*.
- 10 • Exhibit ISS-4: Copies of Rate ES – Environmental Surcharge tariff, both strike-
11 through and clean versions, reflecting the BESF determination.
- 12 • Exhibit ISS-5: An estimate of revenue increases resulting from the inclusion of the
13 2023 plan projects and the estimated bill impact on retail residential customers. See
14 *Excel filename “Exhibit ISS-5 – Residential Impact.xlsx”*.
- 15 • Exhibit ISS-6: Board of Directors Resolution authorizing the amendment to the
16 environmental compliance plan and seeking surcharge recovery.

17 **III. CURRENT ENVIRONMENTAL COMPLIANCE PLAN**
18 **AND THE 2023 PLAN PROJECTS**

19 **Q. PLEASE PROVIDE A BRIEF DESCRIPTION OF EKPC’S CURRENT**
20 **ENVIRONMENTAL COMPLIANCE PLAN.**

21 A. EKPC currently has 25 projects in its Environmental Compliance Plan.¹ Exhibit ISS-1 lists
22 each of the projects, the pollutant or waste/by-product to be controlled, the control facility,

¹ In conjunction with the establishment of a regulatory asset for the undepreciated balance of the William C. Dale Generating Station (“Dale Station”) assets that were being retired early, EKPC was required to remove the costs associated with Project 5, Dale Low Nitrogen Oxide Burners, and the Dale portion of Project 10, Continuous

1 the generating station, the applicable environmental regulation addressed by the project,
2 the applicable environmental permit, the completion date of the project, and the project
3 cost. Projects 1 through 4 were approved by the Commission in Case No. 2004-00321.²
4 Projects 5 through 10 were approved by the Commission in Case No. 2008-00115.³
5 Projects 7 through 9 were amended by and Projects 11 through 13 were approved by the
6 Commission in Case No. 2010-00083.⁴ Project 14 was approved by the Commission in
7 Case No. 2013-00259.⁵ Project 15 was approved by the Commission in Case No. 2014-
8 00252.⁶ Project 16 was approved by the Commission in Case No. 2017-00376.⁷ Project

Monitoring Equipment, from the environmental surcharge mechanism. *See In the Matter of Application of East Kentucky Power Cooperative, Inc. for an Order Approving the Establishment of a Regulatory Asset for the Undepreciated Balance of the William C. Dale Generating Station*, Order, Case No. 2015-00302, (Ky. P.S.C., Feb. 11, 2016). In its last base rate case EKPC was authorized to amortize these regulatory assets. *See In the Matter of Electronic Application of East Kentucky Power Cooperative, Inc. for a General Adjustment of Rates, Approval of Depreciation Study, Amortization of Certain Regulatory Assets, and Other General Relief*, Order, Case No. 2021-00103, (Ky. P.S.C., Sep. 30, 2021). As part of its current application to amend the environmental compliance plan, EKPC is formally removing the Dale Station projects from its environmental compliance plan.

² *See In the Matter of Application of East Kentucky Power Cooperative, Inc. for Approval of an Environmental Compliance Plan and Authority to Implement an Environmental Surcharge*, Order, Case No. 2004-00321, (Ky. P.S.C., Mar. 17, 2005).

³ *See In the Matter of Application of East Kentucky Power Cooperative, Inc. for Approval of an Amendment to Its Environmental Compliance Plan and Environmental Surcharge*, Order, Case No. 2008-00115, (Ky. P.S.C., Sep. 29, 2008).

⁴ *See In the Matter of Application of East Kentucky Power Cooperative, Inc. for Approval of an Amendment to Its Environmental Compliance Plan and Environmental Surcharge*, Order, Case No. 2010-00083, (Ky. P.S.C., Sep. 24, 2010).

⁵ *See In the Matter of Application of East Kentucky Power Cooperative, Inc. for a Certificate of Public Convenience and Necessity for Alteration of Certain Equipment at the Cooper Station and Approval of a Compliance Plan Amendment for Environmental Surcharge Cost Recovery*, Order, Case No. 2013-00259, (Ky. P.S.C., Feb. 20, 2014).

⁶ *See In the Matter of Application of East Kentucky Power Cooperative, Inc. for a Certificate of Public Convenience and Necessity for Construction of an Ash Landfill at J.K. Smith Station, the Removal of Impounded Ash from William C. Dale Station for Transport to J.K. Smith and Approval of a Compliance Plan Amendment for Environmental Surcharge Recovery*, Order, Case No. 2014-00252, (Ky. P.S.C., Mar. 6, 2015).

⁷ *See In the Matter of Application of East Kentucky Power Cooperative, Inc. for Approval to Amend Its Environmental Compliance Plan and Recover Costs Pursuant to Its Environmental Surcharge, Settlement of Certain Asset Retirement Obligations and Issuance of a Certificate of Public Convenience and Necessity and Other Relief*, Order, Case No. 2017-00376, (Ky. P.S.C., May 18, 2018).

1 12 was amended by and Projects 17 through 26 were approved by the Commission in Case
2 No. 2018-00270.⁸

3 **Q. PLEASE DESCRIBE THE ESTIMATED COST OF THE 2023 PLAN PROJECTS.**

4 A. EKPC estimates the total cost of the twenty-five projects making up the 2023 plan projects
5 at \$106.9 million. Of this total, \$15.7 million is associated with the Spurlock Landfill,
6 Peg’s Hill (Area D) Phase 2 project at Spurlock and \$47.2 million is associated with the
7 Cooper Former Impoundment (“CFI”) project at Cooper Station. EKPC is seeking
8 Certificates of Public Convenience and Necessity (“CPCNs”) for both of these projects.
9 The remaining \$44.0 million is associated with twenty-three additional projects located at
10 Spurlock and Cooper Stations.⁹

11 **Q. HOW DOES EKPC PLAN TO FINANCE THE TOTAL COST OF THE 2023 PLAN**
12 **PROJECTS?**

13 A. Mr. Stachnik addresses this question more fully in his testimony and so I will defer to him
14 on the details, but, generally speaking, EKPC has or will use credit available through its
15 short-term Credit Facility to finance the construction of the 2023 plan projects before
16 transitioning that debt to long-term debt issuance, which will be funded in accordance with
17 EKPC’s Trust Indenture.

18 **Q. ONE OF THE 2023 PLAN PROJECTS IS THE SPURLOCK LANDFILL, AREA D,**
19 **PHASE 1 PROJECT. WAS THIS PROJECT INCLUDED AS PART OF**
20 **COMPLIANCE PLAN PROJECT NUMBER 16, THE CCR / ELG PROJECTS?**

⁸ See *In the Matter of Application of East Kentucky Power Cooperative, Inc. for Approval to Amend Its Environmental Compliance Plan and Recover Costs Pursuant to Its Environmental Surcharge, and for the Issuance of a Certificate of Public Convenience and Necessity*, Order, Case No. 2018-00270, (Ky. P.S.C., Apr. 1, 2019).

⁹ See Paragraph 39 of the Application for a summary of the twenty-three projects. However, EKPC believes several of the projects reflect amendments to the current environmental compliance plan projects, and are so noted throughout the application and testimony. The remaining projects, along with the two projects for which EKPC is seeking CPCNs are identified with new environmental compliance plan project reference numbers.

1 A. No. The Spurlock Landfill, Area D, Phase 1 project was referenced several times in the
2 case record for Case No. 2017-00376.¹⁰ At the time the application in that case was filed,
3 EKPC did not seek a CPCN for this project. In its May 18, 2018 Order in Case No. 2017-
4 00376, the Commission found that a CPCN was required prior to the construction of the
5 expansion of the Spurlock landfill, with a separate CPCN required prior to commencing
6 construction on each future phase of the Spurlock landfill. The Commission further found
7 that the first phase expansion was needed for the continued operation of the Spurlock
8 Station and that expansion represented the least-cost option of complying with the Disposal
9 of Coal Combustion Residuals from Electric Utilities Rule (“CCR”) and the Effluent
10 Limitation Guidelines and Standards for the Steam Electric Power Generating Point Source
11 Category (“ELG”) Rules and consequently granted EKPC a CPCN for Area D, Phase 1.¹¹
12 However, EKPC had never included Area D, Phase 1 as a specific project in the compliance
13 plan amendment in Case No. 2017-00376 and the Commission’s May 18, 2018 Order does
14 not list it as one of the components of the environmental compliance plan.¹² EKPC has not
15 included any of the capital costs or associated operating costs for Area D, Phase 1 in its
16 subsequent monthly surcharge filings. Therefore, EKPC wishes to include the Spurlock
17 Landfill, Area D, Phase 1 project as part of its 2023 plan projects.

18 **Q. WHAT DOES EKPC ANTICIPATE WILL BE THE INCREMENTAL**
19 **OPERATIONS AND MAINTENANCE COSTS ASSOCIATED WITH THE 2023**
20 **PLAN PROJECTS UPON COMPLETION?**

¹⁰ The Spurlock Landfill, Area D was referred to as Peg’s Hill in Case No. 2017-00376.

¹¹ See Case No. 2017-00376, May 18, 2018 Order at 23-24.

¹² *Id.*, at 10-13.

1 A. EKPC anticipates that the incremental operations and maintenance (“O&M”) expense
2 associated with the twenty-five proposed projects to be \$1.1 million in 2023 dollars. The
3 table below shows the anticipated annual O&M expenses associated with each project.

Compliance Plan Project Reference No.	Location	Project Description	O&M Expense
Amendment to Project No. 1	Spurlock	Unit 3 Baghouse (Liner)	\$20,000
Amendment to Project No. 3	Spurlock	Unit 1 Sonic Horns	\$18,000
Amendment to Project No. 4	Spurlock	Unit 2 Sonic Horns	\$25,000
Amendment to Project No. 9	Spurlock	Unit 4 Baghouse (Liner)	\$20,000
Amendment to Project No. 11	Cooper	Inlet Hopper Discharge Modification	\$0
Amendment to Project No. 12	Spurlock	Landfill, Area C, Phase 5	\$217,000
Amendment to Project No. 15	Smith	CCR Groundwater Well Monitoring	\$34,500
Amendment to Project No. 16	Spurlock	Lagoon Re-circulation Pumps	\$102,030
Project No. 27	Cooper	Treatment Plant pH Adjustment	\$23,550
Project No. 28	Spurlock	CCR Groundwater Well	\$125,150
Project No. 29	Spurlock	Air Heater Wash Water Pumping System	\$0
Project No. 30	Spurlock	Ash Haul Bridge Expansion Joint Plate Protectors	\$5,000
Project No. 31	Spurlock	Backup Limestone Conveyor	\$15,039
Project No. 32	Spurlock	Fly Ash Silo Exhausters	\$0
Project No. 33	Spurlock	Site Wide Service Water Project	\$26,000
Project No. 34	Spurlock	Units 1 & 2 Fly Ash Silo Dust Suppression System	\$6,000
	Spurlock	Unit 4 Fly Ash Silo Dust Suppression System	\$4,000
Project No. 35	Spurlock	Unit 2 Air Heater Deposition Measure & Control Systems	\$25,000
Project No. 36	Spurlock	WWT and Ash System Platforms	\$0
Project No. 37	Spurlock	Fly Ash Silo Foggers	\$26,088
Project No. 38	Spurlock	Landfill – Haul Road Paving Phase 1	\$35,000
Project No. 39	Spurlock	Landfill, Area D, Ponds & Stream Mitigation	\$27,000
Project No. 40	Spurlock	Landfill, Area D, Phase 1	\$0
	Spurlock	Landfill, Area D, Phase 2	\$242,000
Project No. 41	Cooper	CFI	\$65,000
		Total	\$1,061,357

1 In addition, one of the projects is anticipated to incur additional O&M expenses
2 periodically. For Project No. 39, it is expected that in the first year of operation, O&M
3 expenses will total \$73,000. The additional expense includes survey and documentation
4 of as-built conditions. After the first year of operations, the O&M expense for Project No.
5 39 is expected to be as shown in the table.

6 **IV. SURCHARGE MECHANISM AND THE 2023 PLAN PROJECTS**

7 **Q. DO THE 2023 PLAN PROJECTS MEET THE REQUIREMENTS OF KRS 278.183,** 8 **AND THUS QUALIFY FOR ENVIRONMENTAL SURCHARGE RECOVERY?**

9 A. Yes. I am not an attorney, of course, and cannot make any statements that would be
10 construed to be legal conclusions, but based upon the facts as I know them and my own
11 plain readings of KRS 278.183, the proposed projects satisfy the statutory requirements
12 and therefore qualify for environmental surcharge recovery. The environmental surcharge
13 statute, KRS 278.183, was enacted “to promote the use of high sulfur Kentucky coal by
14 permitting utilities to surcharge their customers for the cost of a scrubber which is part of
15 a power plant that cleans high sulfur coal in order to meet the acid rain provisions of the
16 Federal Clean Air Act amendments of 1990.”¹³ Section 1 of the statute contains the
17 guarantee of cost recovery for such environmental compliance costs:

18 Notwithstanding any other provision of this chapter, effective
19 January 1, 1993, a utility shall be entitled to the current recovery of
20 its costs of complying with the Federal Clean Air Act as amended
21 and those federal, state, or local environmental requirements which
22 apply to coal combustion wastes and by-products from facilities
23 utilized for production of energy from coal in accordance with the
24 utility's compliance plan as designated in subsection (2) of this
25 section. These costs shall include a reasonable return on
26 construction and other capital expenditures and reasonable
27 operating expenses for any plant, equipment, property, facility, or
28 other action to be used to comply with applicable environmental

¹³ *Kentucky Indus. Utility Customers, Inc. v. Kentucky Utilities Co.*, 983 S.W.2d 493, 496 (Ky. 1998).

1 requirements set forth in this section. Operating expenses include all
2 costs of operating and maintaining environmental facilities, income
3 taxes, property taxes, other applicable taxes, and depreciation
4 expenses as these expenses relate to compliance with the
5 environmental requirements set forth in this section.¹⁴

6 As noted in Exhibit ISS-1, the 2023 plan projects are designed to comply with
7 numerous federal and state environmental requirements, including but not limited to the
8 Clean Air Act, the Mercury Air Toxics Standards, the CCR Rule, the ELG Rule, the federal
9 Clean Water Act, and state permits associated with the Kentucky Pollutant Discharge
10 Elimination System requirements. All of these rules and regulations would qualify as
11 federal or state environmental requirements which apply to coal combustion wastes and
12 by-products from facilities utilized for production of energy from coal. Thus, KRS 278.183
13 is applicable to the 2023 plan projects. Both Mr. Jerry Purvis and Mr. Joseph T.
14 VonDerHaar elaborate on the environmental obligations driving the 2023 plan projects in
15 their testimonies.

16 Of course, the statute goes on to describe the process by which a utility may recover
17 its environmental compliance costs through the environmental surcharge. For instance, a
18 utility must “submit to the commission a plan, including any application required by KRS
19 278.020(1), for complying with the applicable environmental requirements set forth in
20 [KRS 278.183(1)].” Following that:

21 ...[T]he commission shall conduct a hearing to: (a) Consider and
22 approve the plan and rate surcharge if the commission finds the plan
23 and rate surcharge reasonable and cost-effective for compliance
24 with the applicable environmental requirements set forth in
25 subsection (1) of this section; (b) Establish a reasonable return on
26 compliance-related capital expenditures; and (c) Approve the
27 application of the surcharge.¹⁵

¹⁴ KRS 278.183(1).

¹⁵ KRS 278.183(2).

1 The Kentucky Supreme Court characterized KRS 278.183 as “a new right” that
2 “did not exist before the enactment of the surcharge.”¹⁶ Thus, the Kentucky General
3 Assembly has chosen to encourage the use of coal by enacting a surcharge mechanism that
4 guarantees a utility the ability to recover costs associated with compliance with
5 environmental mandates. The Commission has itself commented upon the prescriptive
6 nature of KRS 278.183 by observing that it “must consider the plan and the proposed rate
7 surcharge, and approve them if [the Commission] finds the plan and rate surcharge to be
8 reasonable and cost effective.”¹⁷ The environmental surcharge statute, therefore, relates to
9 and is an important adjunct to the traditional CPCN analysis required by KRS 278.020(1).
10 Again, from this perspective, the 2023 plan projects would clearly appear to qualify for
11 cost recovery under the environmental surcharge statute as set forth in KRS 278.183.

12 **Q. PLEASE DISCUSS THE RETURN EKPC WOULD PROPOSE FOR THE 2023**
13 **PLAN PROJECTS.**

14 A. As described by Mr. Stachnik in his testimony, EKPC is proposing an overall rate of return
15 of 6.487%, which is the product of applying a 4.398% average cost of debt to a 1.475
16 TIER.¹⁸ EKPC is further proposing that this rate of return be applied to all the projects in
17 its environmental compliance plan, not just the 2023 plan projects. Following this

¹⁶ *Kentucky Indus. Utility Customers, Inc.*, at 500.

¹⁷ See *In the Matter of the Application of Big Rivers Electric Corporation for Approval of its 2012 Environmental Compliance Plan*, Order, Case No. 2012-00063, p. 16, (Ky. P.S.C., Oct. 1, 2012).

¹⁸ This determination of the overall rate of return for the environmental compliance rate base utilizing the average cost of debt for the debt issuances directly related to projects in the approved environmental compliance plan multiplied by the authorized TIER was established in Case No. 2004-00321. EKPC has consistently followed this approach in every six-month and two-year surcharge review proceeding. As a result of the settlement agreement in Case No. 2021-00103, EKPC’s rate of return on environmental compliance rate base also includes a cost of debt component for construction work in progress included in the environmental compliance rate base. The interest rate of EKPC’s credit facility is used to determine this portion of the cost of debt. The TIER of 1.475 was also a result of the settlement agreement in Case No. 2021-00103.

1 approach will allow EKPC’s monthly environmental surcharge filings to reflect a more
 2 current cost of debt.

3 **Q. PLEASE DISCUSS HOW THE 2023 PLAN PROJECTS WOULD BE REFLECTED**
 4 **IN EKPC’S ENVIRONMENTAL SURCHARGE MECHANISM.**

5 A. The expenditures under the 2023 plan projects fall into three specific categories: facilities
 6 already constructed and in service at the Spurlock and Cooper Stations, the construction of
 7 additional facilities at the Spurlock and Cooper Stations, and expenditures to be expensed
 8 as incurred at Cooper Station. The following table breaks down the projects into these
 9 categories.

Category of Project	Compliance Plan Project Reference	Cost	Total Category Cost
Facilities Already Constructed and In Service	Amended Projects 1, 3, 4, 9, 11, 12 & 15	\$16,448,255	\$23,385,863
	Projects 27 & 28	\$272,321	
	Projects 30 – 32	\$3,943,546	
	Projects 34 & 35	\$624,545	
	Project 38	\$2,097,196	
Facilities under Construction or to be Constructed	Amended Project 16	\$1,285,901	\$36,306,526
	Project 29	\$2,002,438	
	Project 33	\$342,448	
	Projects 36 & 37	\$969,289	
	Projects 39 & 40	\$31,706,450	
Project Expenditures to be Expensed as Incurred	Project 41	\$47,200,000	\$47,200,000
Total 2023 Plan Projects		\$106,892,389	\$106,892,389
Total all Projects, Paragraph 39 of Application			\$43,962,389
Total Spurlock Landfill, Area D, Phase 2, Paragraph 26 of Application			\$15,730,000
Total CFI Project, Paragraph 33 of Application			\$47,200,000
Total 2023 Plan Projects			\$106,892,389

10 For the facilities already constructed and in service, EKPC is proposing to include
 11 the original cost and the applicable accumulated depreciation for these projects in the
 12 environmental compliance rate base. The balance for the accumulated depreciation will be
 13 as of the end of the month in which the Commission’s Order approving the inclusion of
 14 these projects in EKPC’s amended environmental compliance plan is issued. EKPC is also

1 proposing that it be permitted to begin recovery of the depreciation, return, insurance
2 expense, taxes, and operation and maintenance expenses associated with the completed
3 projects included in the 2023 plan projects. These costs will reflect the going forward
4 levels of cost associated with these projects and will not include the recovery of costs
5 incurred prior to the Commission’s approval of the inclusion of the projects in the amended
6 environmental compliance plan.

7 For the construction of the additional facilities, EKPC is proposing that it be
8 permitted to earn a return on the monthly Construction Work In Progress (“CWIP”)
9 balance. This request is consistent with the treatment approved in Case No. 2008-00115.
10 Upon completion, EKPC is proposing that it be permitted to begin recovery of depreciation,
11 return, insurance expense, taxes, and operation and maintenance expenses associated with
12 the 2023 plan projects.

13 For the expenditures associated with the CFI project, EKPC is proposing the
14 recovery of those costs be expensed and recovered through the environmental surcharge as
15 they are incurred. EKPC believes this approach is consistent with the rate-making
16 treatment followed for the Dale Station ash hauling costs in Case No. 2014-00252 and the
17 Spurlock ash pond closure costs in Case No. 2017-00376. In Case No. 2014-00252 the
18 Commission found that the Dale Station ash hauling costs did not extend the life of the
19 existing Dale Ash Ponds or add value to the new Smith landfill. In Case No. 2017-00376
20 the Commission accepted EKPC’s reasoning that the Spurlock ash pond closure activities
21 did not extend the life of the ash pond or add value to the ash pond site. Likewise, the CFI
22 project will be closing the impoundment in place and neither extends the life of the
23 impoundment nor adds value to the impoundment. Therefore, EKPC believes the

1 appropriate rate-making treatment for the CFI project is to expense and recover those costs
2 through the environmental surcharge as the costs are incurred.

3 **V. BESF AND RATE ES TARIFF REVISION**

4 **Q. WILL INCLUSION OF THE 2023 PLAN PROJECTS IN EKPC'S APPROVED**
5 **ENVIRONMENTAL SURCHARGE COMPLIANCE PLAN REQUIRE ANY**
6 **REVISIONS TO EKPC'S RATE ES-ENVIRONMENTAL SURCHARGE?**

7 A. Yes. EKPC has determined that an updated BESF will need to be reflected in the Rate ES
8 – Environmental Surcharge tariff.

9 **Q. WILL THE 2023 PLAN PROJECTS RESULT IN THE EARLY RETIREMENT OR**
10 **ABANDONMENT OF ANY EXISTING UTILITY PLANT ASSETS PRIOR TO**
11 **THE EXPECTED RETIREMENT DATE OF THE ASSETS?**

12 A. EKPC does not believe the 2023 plan projects will result in an early retirement or
13 abandonment of existing utility plant assets prior to the expected retirement date of the
14 assets.

15 **Q. WILL THE 2023 PLAN PROJECTS RESULT IN AN AMOUNT TO BE**
16 **RECOGNIZED IN THE BESF COMPONENT OF THE SURCHARGE**
17 **MECHANISM?**

18 A. Yes, but the BESF component will not be the result of early retirements or abandonments
19 associated with the 2023 plan projects. The BESF component will be the result of several
20 of the 2023 plan projects having costs that are being recovered in existing base rates. EKPC
21 reviewed its accounting records and determined that several of the 2023 plan projects were
22 reflected in the account balances as of December 31, 2019, the test year in EKPC's last
23 base rate case. Included in these account balances were the original costs for plant in
24 service, CWIP, accumulated depreciation, depreciation expense, property taxes, and

1 property insurance expense. At the time of the last base rate case, none of these projects
2 were part of EKPC's environmental compliance plan approved by the Commission.
3 Because of this, the costs associated with those projects were not part of EKPC's proposed
4 adjustments to remove environmental surcharge-related costs from the test year.
5 Consequently, these levels of costs and expenses are currently recovered through EKPC's
6 base rates. In order to avoid double recovery of these costs and expenses and complying
7 with the provisions of KRS 278.183(2), EKPC has calculated an updated BESF to reflect
8 those costs and expenses already recovered in base rates. Exhibit ISS-3 shows the
9 calculation of the updated BESF.

10 This updated BESF would be in addition to the BESF update EKPC proposed in
11 Case No. 2022-00141,¹⁹ a 30-month surcharge review case which is still pending before
12 the Commission. The sources for the BESF proposed in Case No. 2022-00141 and the
13 BESF proposed in this application do not overlap. Therefore, the two BESF components
14 can be added together and stated as a single BESF in the Rate ES tariff. Exhibit ISS-4
15 contains a strike-through and clean version of the updated Rate ES tariff.

16 VI. CUSTOMER BILL IMPACT

17 **Q. Please describe how the inclusion of the 2023 plan projects in EKPC's environmental**
18 **surcharge will impact the bills of EKPC's wholesale owner-members and the owner-**
19 **members' retail customers.**

20 **A.** As of the filing date of this application, seventeen of the twenty-five 2023 plan projects are
21 already completed and in service. Of the remaining eight plan projects, six are expected to

¹⁹ See *In the Matter of An Electronic Examination by the Public Service Commission of the Environmental Surcharge Mechanism of East Kentucky Power Cooperative, Inc. for the Sixth-Month Expense Periods Ending November 30, 2019, May 31, 2020, November 30, 2020, and November 30, 2021, the Two-Year Expense Period Ending May 31, 2021, and the Pass-Through Mechanism of Its Sixteen Member Distribution Cooperatives*, Case No. 2022-00141.

1 be completed and in service by the end of 2023, which would approximately correspond
2 with the expected decision date for this application. The Spurlock Landfill, Peg’s Hill
3 (Area D) Phase 2 portion of Project No. 40 is expected to be completed and in service by
4 the end of 2024. The CFI project, Project No. 41, is expected to be completed by January
5 2027. Because of these timing differences, the annual revenue requirement impact will
6 fluctuate year to year. EKPC has estimated the annual revenue requirements as of the end
7 of the calendar years 2024 through 2027. EKPC chose these dates to reflect the impact of
8 the 2023 plan projects on the surcharge approximately one, two, three, and four years after
9 the approval date. The table below shows the estimated annual revenue requirement, the
10 approximate increase in the environmental surcharge for all customer classes at wholesale,
11 the approximate increase passed through to retail customers, and the estimated increase in
12 an average residential customer’s monthly bill.²⁰ The calculation of these estimates is
13 provided in Exhibit ISS-5 and incorporates the BESF determined in Exhibit ISS-3.

Calendar Year Ending	Estimated Annual Revenue Requirement	Percentage Increase Wholesale	Percentage Increase Retail	Estimated Increase in Average Residential Monthly Bill
2024	\$4,847,602	0.43%	0.31%	\$0.31
2025	\$21,626,957	1.90%	1.37%	\$1.36
2026	\$31,725,881	2.79%	2.01%	\$2.00
2027	\$5,194,265	0.46%	0.33%	\$0.32

14 **VII. MONTHLY REPORTING FORMATS**

15 **Q. Will any revisions to the monthly environmental surcharge reporting forms be**
16 **necessary?**

²⁰ EKPC’s rate schedules do not directly correspond to retail customer classifications. For illustrative purposes, I have approximated the impact on an average monthly residential bill reflecting a monthly usage of 1,125 kWh. This approximation reflects a best estimate of the impact and is not based on an analysis of residential billing information.

1 A. Yes. The proposed revisions to the monthly reporting formats are shown in Exhibit ISS-2.
2 EKPC believes that some revisions to the monthly environmental surcharge reporting
3 formats will be needed. EKPC is proposing the following revisions:

- 4 • ES Form 1.0 – EKPC is proposing to update the BESF line item to reflect the BESF
5 determined in Exhibit ISS-3.
- 6 • ES Form 1.1 – EKPC is proposing to update the Rate of Return on Line 4 and the
7 BESF amount on Line 17.
- 8 • ES Form 2.0 – Under the Determination of Pollution Control Operating Expenses
9 section, EKPC is proposing two revisions. First, to add the line item titled
10 “Monthly Project 41 Related CFI” that will present the monthly costs associated
11 with the CFI project as reported on ES Form 2.12. Second, to delete the line item
12 titled “Monthly Project 12/17 Related Landfill Closure – ARO” as this monthly
13 amortization is completed.
- 14 • ES Form 2.1 – EKPC is proposing to expand this format to three pages, given that
15 the 2023 plan projects will result in the addition of 16 new projects.²¹ At the bottom
16 of the first page, “Total” has been replaced with “Subtotals, Page 1 of 3”. The
17 second page starts with a carry-over of the subtotals from page 1 of 3 and then lists
18 Project Nos. 17 through 28. At the bottom of the second page, “Totals, All Pages”
19 has been replaced with “Subtotals, Pages 1 & 2 of 3”. A third page starts with the
20 same title and column headings follow. The third page starts with a carry-over of

²¹ While 16 new projects are being added to this reporting format, there are only 14 additional compliance plan project reference numbers. As noted previously in my testimony, Project No. 34 combines under one reference number two projects associated with fly ash silo dust suppression systems at Spurlock Units 1, 2, and 4. Project No. 40 combines under one reference number the Spurlock Landfill, Area D, Phases 1 and 2.

1 the subtotals from pages 1 and 2 of 3 and then lists Project Nos. 29 through 40. At
2 the bottom of the third page are the combined totals for all pages.

- 3 • ES Form 2.12 – EKPC is proposing two revisions to this format. First, to delete
4 the section of this format to report the amortization of the costs incurred in
5 conjunction with the Spurlock and Cooper landfill closures, Amended Project No.
6 12 and Project No. 17. The amortization of costs this section tracked is completed
7 and no longer needed for the monthly surcharge filing. Second, to add a section to
8 this format to report the monthly and cumulative costs associated with Project No.
9 41, the CFI project.

- 10 • ES Form 2.5 – EKPC is proposing to include two additional operating and
11 maintenance expense accounts under Section IV. The first additional account is
12 Maintenance for the CFI Closure, Project No. 41. After the impoundment closure
13 is completed in 2027, EKPC will continue to incur expenses for cover, vegetation
14 and miscellaneous maintenance, mowing, and cost for inspections. EKPC
15 estimates that these expenses would be approximately \$65,000 per year. The
16 second additional account is Maintenance for the Smith Special Waste Landfill,
17 Project No. 15. In Case No. 2014-00252 EKPC sought 1) a CPCN for the Smith
18 Special Waste Landfill project, 2) an amendment to its environmental compliance
19 plan to include this project, and 3) recovery of the project costs through the
20 surcharge mechanism. In its application, EKPC estimated that annual operation
21 and maintenance expenses would be \$26,132, but noted that every fifth year the
22 annual expense could increase to \$68,266. EKPC had proposed to include the

1 operation and maintenance expense for this project in ES Form 2.5.²² The
2 Commission granted the requested CPCN and amendment to EKPC's
3 environmental compliance plan in its March 6, 2015 Order. However, EKPC failed
4 to utilize the amended ES Form 2.5 to record and recover the operation and
5 maintenance expense for the Smith Special Waste Landfill. While preparing the
6 current application EKPC discovered this oversight and requests it be permitted to
7 include this expense going forward, as shown in Exhibit ISS-2. EKPC is not
8 seeking to recover previously incurred operation and maintenance expenses for the
9 Smith Special Waste Landfill, but would begin current recovery of those expenses
10 effective with the date this application is approved.

11 **Q. Did EKPC provide advanced notice of its intent to file an Application to amend its**
12 **Environmental Compliance Plan and environmental surcharge?**

13 A. Yes. Pursuant to KRS 278.183(2), EKPC has given at least thirty (30) days' advanced
14 notice of its intent to file its Application to Amend its Environmental Compliance Plan and
15 Environmental Surcharge. On May 19, 2023, EKPC provided such notice to the
16 Commission, a copy of which is attached as Exhibit C to the Application submitted by
17 EKPC in this matter. EKPC's also provided notice to its member distribution cooperatives
18 on or about June 27, 2023, which notice is attached as Exhibit D to the Application
19 submitted by EKPC in this matter.

20 **Q. Please summarize your testimony.**

²² See Case No. 2014-00252, Application Exhibit 11, Direct Testimony of Isaac S. Scott, at page 5 and Exhibit ISS-2, page 2 of 2. In that application EKPC had proposed to report operation and maintenance expenses associated with the Smith Special Waste Landfill on ES Form 2.5 under Account No. 506 – Miscellaneous Steam Power Expenses. Upon further review in preparation for the current application, EKPC is now proposing that the appropriate reporting on ES Form 2.5 is under Account No. 512 – Maintenance of Boiler Plant.

1 A. Based on its understanding of KRS 278.183, EKPC believes the costs of the 2023 plan
2 projects are eligible for, and should be recovered through, the environmental surcharge.
3 EKPC is requesting that during construction it be allowed to earn a return on the
4 appropriate balance of CWIP. EKPC further requests that the rate of return utilized to
5 determine that return be the rate of return established for its other environmental
6 compliance plan projects. EKPC has determined a BESF to be reflected in future monthly
7 surcharge filings to recognize those 2023 plan projects that have some recovery of costs
8 through existing base rates. EKPC has described the impact the 2023 plan projects would
9 have on retail residential customers' bills. I recommend that the Commission approve
10 EKPC's request to amend its Environmental Compliance Plan to include the 2023 plan
11 projects and include the 2023 plan projects for recovery through the surcharge mechanism.

12 **Q. Does this conclude your testimony?**

13 A. Yes.

EXHIBIT

ISS-1

EAST KENTUCKY POWER COOPERATIVE, INC ENVIRONMENTAL COMPLIANCE PLAN PURSUANT TO ENVIRONMENTAL SURCHARGE LAW							
(1)	(2)	(3)	(4)	(5)	(6)	(7)	(8)
Project Reference	Pollutant or Waste/By-Product To be Controlled	Control Facility	Generating Station	Environmental Regulation	Environmental Permit	Actual or Scheduled Completion	Actual (A) or Estimated (E) Project Cost
2023 Amendment	Fly Ash/Particulate NOx & SO2	Boiler SNCR Baghouse Flash Dry Absorber	Gilbert	401 KAR Chap 45 CAA Sec.404 40 CFR Part 72 401 KAR 50:035 CAA Sec.407 40 CFR Part 76	081-0005 V-97-050 (Rev. 1)	2005	\$69.6 M (A)
	Mercury, Particulate Matter (PM) & HAPs	PJTT Baghouse	Gilbert	40 CFR Part 63	V-15-063 R1	April 2020	\$5.5 M (A)
2.	Particulate	Precipitator	Spurlock 1	401 KAR 61:015	V-95-050 (Rev. 1)	2003	\$24.3 (A)
2023 Amendment	NOx	SCR	Spurlock 1	CAA Sec. 407 40 CFR Part 76	V-97-050	2003	\$84.4 M (A)
	Coal Combustion Residuals (CCR)	SCR	Spurlock 1	42 CFR 257 401 KAR Chap. 46	SW08100005	May 2020	\$0.2 M (A)
2023 Amendment	NOx	SCR	Spurlock 2	CAA Sec. 407 40 CFR Part 76	V-97-050	2002 Fall 2007 & Spring 2008	\$47.2 (A)
	CCR	SCR	Spurlock 2	42 CFR 257 401 KAR Chap. 46	SW08100005	Dec. 2017	\$0.2 M (A)
5.	This project was associated with the Dale Station, which has been retired. The Commission's February 11, 2016 Order in Case No. 2015-00302 authorized the creation of regulatory assets for the undepreciated balance of the Dale Station assets. Further, the Commission authorized the recovery of these regulatory assets through base rates in Case No. 2021-00103. Consequently, costs associated with Project 5 and the Dale portion of Project 10 are no longer included in the environmental compliance plan or surcharge.						
6.	NOx	NOx Reduction Equipment	Spurlock 1	40 CFR Part 76.7 CAN 04-34-KSF	V-06-007	Spring 2009	\$3.09 M (A)
2010 Amendment 2010 Amendment	SO2	Scrubber	Spurlock 2	CAN 04-34-KSF CAA Sec 405	V-97-050 Rev. 1	Oct. 2008	\$194.1 M (A)
		Switchyard Improvements Isolation Valve	Spurlock 2 Scrubber	40 CFR Part 76.7 CAN 04-34-KSF CAA Sec 405 CAA Sec 404	V-06-007, Rev 2	In Svce Fall 2010	\$8.396 M (A) \$787,793 (A)
2010 Amendment 2010 Amendment	SO2	Scrubber	Spurlock 1	CAN 04-34-KSF CAA Sec 404	V-97-050 Rev. 1	Spring 2009	\$145.8 M (A)
		Switchyard Improvements Isolation Valve	Spurlock 1 Scrubber	40 CFR Part 76.7 CAN 04-34-KSF CAA Sec 405 CAA Sec 404	V-06-007, Rev 2	In Svce Spring 2011	\$1.26 M (A) \$677,992 (A)

**EAST KENTUCKY POWER COOPERATIVE, INC
ENVIRONMENTAL COMPLIANCE PLAN
PURSUANT TO ENVIRONMENTAL SURCHARGE LAW**

(1)	(2)	(3)	(4)	(5)	(6)	(7)	(8)
Project Reference	Pollutant or Waste/By-Product To be Controlled	Control Facility	Generating Station	Environmental Regulation	Environmental Permit	Actual or Scheduled Completion	Actual (A) or Estimated (E) Project Cost
9. 2010 Amendment 2023 Amendment	Fly Ash/Particulate NOx & SO2	Boiler SNCR Baghouse Flash Dry Absorber	Spurlock 4	401 KAR Chap 45 CAA Sec.404 40 CFR Part 72 401 KAR 50:035 CAA Sec.407 40 CFR Part 76	V-06-007	April 2009	\$84.8 M (A)
		Ash Silos	Spurlock 4	401 KAR 63:010	V-06-007	Summer 2010	\$11.7 M (A)
	Mercury, PM, HAPs	PJTT Baghouse	Spurlock 4	40 CFR Part 63	V-15-063 R1	Nov. 2020	\$4.8 M (A)
10.	PM & Mercury CEMS	Stack Emissions Monitoring	Spurlock Cooper	40 CFR Part 60 App. B, PS 11, & App. F Proced. 2. CD para 97-102. 40 CFR 75	CAN 04-34-KSF	Spring 2010	\$2.9 M (A)
11 2023 Amendment	NOx and SO2, PM	Air Quality Control System	Cooper 2	Consent Decree CAN 04-34-KSF KY BART SIP	V-05-082 R1	Summer 2012	\$222 M (A)
	PM, HAPs, SOx	PJTT Baghouse	Cooper 2	40 CFR 50 40 CFR 63	V-18-027	June 2018	\$0.4 M (A)
12 2018 Amendment 2023 Amendment	Coal Combustion by-products (CCB)	Landfill Area C Expansion and Sediment Pond Construction	Spurlock 1, 2, 4, Gilbert; Spur 1, 2 Scrubbers	Clean Water Act (CWA) Section 404	KPDES No. KY0022250	Fall 2010	\$6.5 M (E)
	CCR and Special Waste	Area C - Phases Two through Four	Spurlock 1, 2, 4, Gilbert	40 CFR 257 401 KAR Chap 45 401 KAR Chap 46 CWA Section 404	SW08100005	In Svce Fall 2018	\$8.6 M (A) \$10.7 M (E)
	CCR	Area C, Phase Five	Spurlock	40 CFR 257 401 KAR Chap. 46	SW08100005	Jan. 2022	\$5.1 M (A)
13	SOx, H2SO4, Mercury	Replacement of Retired Ductwork	Spurlock 2	CFR Title 40, Part 51 CFR Title 40, Part 52 (New Source Review)	V-06-007	Spring 2010	\$2.8 M (A)
14	NOx and SO2, PM	Ductwork to Connect to Existing Air Quality Control System	Cooper 1	Mercury Air Toxics Rule, 40 CFR Parts 60 & 63 EPA BART & KY BART SIP; 40 CFR Parts 51 & 52	V-05-082R1	Summer 2016	\$15 M (E)

**EAST KENTUCKY POWER COOPERATIVE, INC
ENVIRONMENTAL COMPLIANCE PLAN
PURSUANT TO ENVIRONMENTAL SURCHARGE LAW**

(1)	(2)	(3)	(4)	(5)	(6)	(7)	(8)
Project Reference	Pollutant or Waste/By-Product To be Controlled	Control Facility	Generating Station	Environmental Regulation	Environmental Permit	Actual or Scheduled Completion	Actual (A) or Estimated (E) Project Cost
15	CCB	Ash Special Waste Landfill Construction	Smith	Regulations proposed at 75 Fed. Reg. 35128 (June 21, 2010) that are anticipated to be finalized in 40 CFR Parts 257, 261, 264, 265, 268, 271, and 302; 401 KAR Sec. 45; 401 KAR 5:055; 401 KAR 63:010	USACE Individual 404 Permit # LRL-2012-455-mdh; KY Division of Water (KDOW) KPDES Permit # KY0055972; KDOW 401 Water Quality Certification # 2012-049-7R; KY Division of Waste Permit # 025-00022	Nov. 2017	\$27 M (E)
2023 Amendment	CCR	Groundwater Monitoring Well	Smith	40 CFR 257 401 KAR Chap. 46	SW02500022	June 2017	\$0.3 M (A)
16	Non-hazardous Waste and Steam Effluent Water Quality Standards	CCR Rule units and Industrial Water Discharges	Spurlock	40 CFR 257; 40 CFR 261; 40 CFR 423; 401 KAR Sec. 46; KRS Chap. 224	Permit Revision forthcoming for KPDES Permit No. KY0022250; KDWM Waste Permit #SW08100005; #SW08100019	Nov. 2024	\$262.4 M (E)
2023 Amendment	Effluent Limitation Guidelines (ELG)	Waste Water Treatment	Spurlock	40 CFR Part 423	KY0022250	June 2023	\$1.3 M (E)
17	Special Waste	Waste Landfill	Cooper	401 KAR Chap 45 KRS Chap 224	SW10000015	In Svce	\$6.2 M (A)
18	Special Waste	Landfill - Sediment Pond	Cooper	401 KAR Chap 45 KRS Chap 224	SW10000015	In Svce	\$2.2 M (A)
19	Special Waste	KY Waste Facility	Cooper	401 KAR Chap 45 KRS Chap 224 401 KAR 63:010	SW10000015 V-12-019R1	In Svce	\$0.3 M (A)
20	Special Waste	KY Waste Facility	Cooper	401 KAR Chap 45 KRS Chap 224	SW10000015	In Svce	\$1.2 M (A)
21	CCR and Stormwater	Station Drainage Improvement Facilities	Spurlock	CWA Section 402 KRS Chap 224 40 CFR 257 401 KAR 63:010	V-15-063 KY0022250	In Svce	\$13.1 M (A)
22	Mercury	Hg Removal Equipment	Spurlock	40 CFR 60 40 CFR 63 401 KAR 63:020	Title V in renewal to incorporate 40 CFR 63	In Svce	\$2.8 M (A)

**EAST KENTUCKY POWER COOPERATIVE, INC
ENVIRONMENTAL COMPLIANCE PLAN
PURSUANT TO ENVIRONMENTAL SURCHARGE LAW**

(1)	(2)	(3)	(4)	(5)	(6)	(7)	(8)
Project Reference	Pollutant or Waste/By-Product To be Controlled	Control Facility	Generating Station	Environmental Regulation	Environmental Permit	Actual or Scheduled Completion	Actual (A) or Estimated (E) Project Cost
23	NH3	Anhydrous Ammonia Containment	Spurlock	40 CFR 112 CAA Sec 112(r)	Spurlock Spill Prevention Control & Counter-measure plan; Risk Management plan	In Svce	\$1.1 M (A)
24	CCR and PM	Spurlock Facilities	Spurlock	40 CFR 257 401 KAR Chap 46 401 KAR 59:010	V-15-063	Fall 2018	\$2.7 M (E)
25	SO3, NH3	Dry Sorbent Injection System	Spurlock	40 CFR 63	V-15-063	In Svce	\$3.9 M (A)
26	Special Waste	KY Waste Facility	Spurlock	401 KAR Chap 45 CWA Section 404	SW08100005	Feb. 2021	\$11.2 M (E)
27	KY Water Quality Standards (WQS)	Waste Water Treatment	Cooper	40 CFR Part 423	KY0003611	Dec. 2019	\$0.02 M (A)
28	CCR	Groundwater Monitoring Well	Spurlock	40 CFR 257 401 KAR Chap. 46	SW08100005	April 2017	\$0.2 M (A)
29	KY WQS	Waste Water Treatment	Spurlock	40 CFR 50 40 CFR Part 423	V-15-063R1 KY0022250	Sept. 2022	\$2.0 M (A)
30	CCR	Landfill	Spurlock	40 CFR 257 401 KAR Chap. 46	SW08100005	Nov. 2020	\$0.3 M (A)
31	PM, CCR	Fugitive Dust Control	Spurlock	40 CFR 50 40 CFR 257 401 KAR Chap. 46	V-15-063 R1	March 2020	\$2.6 M (A)
32	PM, CCR	Bin Vent Filters Fugitive Dust Control	Spurlock	40 CFR 50 40 CFR 257 401 KAR Chap. 46	V-15-063 R1 SW08100005	May 2020	\$1.0 M (A)
33	ELG	Waste Water Treatment	Spurlock	40 CFR Part 423	KY0022250	Dec. 2023	\$0.3 M (E)
34	PM, CCR	Fugitive Dust Control	Spurlock 1, 2 & 4	40 CFR 50 40 CFR 257 401 KAR Chap. 46	V-15-063 R1 SW08100005	Dec. 2018	\$0.2 M (A)
35	Mercury, PM, HAPs	WFGD, WESP	Spurlock 2	40 CFR 50 40 CFR Part 63	V-15-063 R1	Dec. 2017	\$0.4 M (A)

EAST KENTUCKY POWER COOPERATIVE, INC ENVIRONMENTAL COMPLIANCE PLAN PURSUANT TO ENVIRONMENTAL SURCHARGE LAW							
---	--	--	--	--	--	--	--

(1)	(2)	(3)	(4)	(5)	(6)	(7)	(8)
Project Reference	Pollutant or Waste/By-Product To be Controlled	Control Facility	Generating Station	Environmental Regulation	Environmental Permit	Actual or Scheduled Completion	Actual (A) or Estimated (E) Project Cost
36	CCR, KY WQS	Waste Water Treatment	Spurlock	40 CFR 257 401 KAR Chap. 46 40 CFR Part 423	SW08100005 KY0022250	Aug. 2023	\$0.7 M (E)
37	PM, CCR	Fugitive Dust Control	Spurlock	40 CFR 50 40 CFR 257 401 KAR Chap. 46	V-15-063 R1 SW08100005	March 2023	\$0.3 M (E)
38	CCR	Fugitive Dust Control	Spurlock	41 CFR 257 401 KAR Chap. 46	SW08100005	Nov. 2020	\$2.1 M (A)
39	CCR, ELG	Landfill, Sedimentation Basin and Water Treatment	Spurlock	401 KAR Chap. 46 CWA Sec. 404 40 CFR 257 40 CFR 423	SW08100005 KY0022250	Nov. 2022	\$11.0 M (E)
40	CCR, ELG	Landfill, Sedimentation Basin and Water Treatment Area D, Phase One	Spurlock	401 KAR Chap. 46 CWA Sec. 404 40 CFR 257 40 CFR 423	SW08100005 KY0022250	Sept. 2023	\$5.0 M (E)
	CCR	Landfill Area D, Phase Two	Spurlock	401 KAR Chap. 46 CWA Sec 404 40 CFR 257	SW08100005	2024	\$15.7 M (E)
41	CCB, KY WQS	Special Waste / Surface & Stormwater Control	Cooper	CWA Sec 404 401 KAR Chap. 45 40 CFR 122 401 KAR 5:065	KY0003611	2023-2027	\$47.2 M (E)

EXHIBIT

ISS-4

Rate ES – Environmental Surcharge

Applicability

In all territories of owner-members of EKPC.

T

Availability

This rate schedule shall apply to EKPC Rates B, C, E, and G and all special contracts with rates subject to adjustment upon the approval of the Commission.

T

Rate

The Environmental Surcharge shall provide for monthly adjustments based on a percent of revenues equal to the difference between the environmental compliance costs in the base period and in the current period based on the following formula:

$$\text{CESF} = \text{E(m)} / \text{R(m)}$$

$$\text{MESF} = \text{CESF} - \text{BESF}$$

MESF = Monthly Environmental Surcharge Factor

CESF = Current Environmental Surcharge Factor

BESF = Base Environmental Surcharge Factor of ~~0%~~ 0.34%

where E(m) is the total of each approved environmental compliance plan revenue requirement of environmental costs for the current expense month and R(m) is the revenue for the current expense month as expressed below.

Definitions

1. $E(m) = [(RB/12)(RORB) + OE - BAS + (Over)Under Recovery$

where:

- a. RB is the Environmental Compliance Rate Base, defined as electric plant in service for applicable environmental projects adjusted for accumulated depreciation, CWIP, cash working capital, spare parts and limestone inventory, emission allowance inventory;
- b. RORB is the Rate of Return on the Environmental Compliance Rate Base, designated as the average cost of debt for environmental compliance plan projects approved by the Commission plus application of a times-interest-earned ratio of 1.475;

R

DATE OF ISSUE: ~~April 1, 2024~~

DATE EFFECTIVE: Service rendered on and after ~~October 1, 2024~~

ISSUED BY:

 Anthony S. Campbell,
 President and Chief Executive Officer

Issued by authority of an Order of the Public Service Commission of Kentucky in Case No. ~~2021-00403~~ 2023-00177 dated ~~September 30, 2024~~.

Rate ES – Environmental Surcharge

Applicability

In all territories of owner-members of EKPC.

Availability

This rate schedule shall apply to EKPC Rates B, C, E, and G and all special contracts with rates subject to adjustment upon the approval of the Commission.

Rate

The Environmental Surcharge shall provide for monthly adjustments based on a percent of revenues equal to the difference between the environmental compliance costs in the base period and in the current period based on the following formula:

$$CESF = E(m) / R(m)$$

$$MESF = CESF - BESF$$

MESF = Monthly Environmental Surcharge Factor
CESF = Current Environmental Surcharge Factor
BESF = Base Environmental Surcharge Factor of 0.34%

where E(m) is the total of each approved environmental compliance plan revenue requirement of environmental costs for the current expense month and R(m) is the revenue for the current expense month as expressed below.

Definitions

1. $E(m) = [(RB/12)(RORB) + OE - BAS + (Over)Under Recovery$

where:

- a. RB is the Environmental Compliance Rate Base, defined as electric plant in service for applicable environmental projects adjusted for accumulated depreciation, CWIP, cash working capital, spare parts and limestone inventory, emission allowance inventory;
- b. RORB is the Rate of Return on the Environmental Compliance Rate Base, designated as the average cost of debt for environmental compliance plan projects approved by the Commission plus application of a times-interest-earned ratio of 1.475;

DATE OF ISSUE:

DATE EFFECTIVE: Service rendered on and after

ISSUED BY:

Anthony S. Campbell,
President and Chief Executive Officer

Issued by authority of an Order of the Public Service Commission of Kentucky in Case No. 2023-00177 dated .

EXHIBIT

ISS-6

**FROM THE MINUTE BOOK OF PROCEEDINGS
OF THE BOARD OF DIRECTORS OF
EAST KENTUCKY POWER COOPERATIVE, INC.**

At a regular meeting of the Board of Directors of East Kentucky Power Cooperative, Inc. held at the Headquarters Building, 4775 Lexington Road, located in Winchester, Kentucky, on Tuesday, April 11, 2023 at 9:30 a.m., EDT, the following business transacted:

Approval to Amend the Environmental Surcharge Compliance Plan and Seek to Recover Costs Associated with the Specifically Identified Projects

After review of the applicable information, Strategic Issues Chairman Boris Haynes made a motion for approval to amend the Environmental Surcharge Compliance Plan and seek to recover costs associated with the specifically identified projects, seconded by Landis Cornett, and passed by the full Board to approve the following:

- CPCN Project – Spurlock Landfill - Area D Phase 2 Construction – (\$15,730,000) new project
- CPCN Project – CFI - Privileged & Confidential – (\$47,200,000) new project
- Project #OS517 – Spurlock Air Heater Wash Water Pumping System - 2021-2022 – (\$2,002,438) still under construction
- Project #OS543 – Spurlock Lagoon Re-circulation Pumps – (\$1,285,901) still under construction
- Project #OS547 – Spurlock Site Wide Service Water Project, Phase 1 – (\$342,448) still under construction
- Project #OS550 – Spurlock Waste Water Treatment and Ash System Platforms – (\$700,000) still under construction
- Project #OS554 – Spurlock Fly Ash Silo Foggers – (\$269,289) still under construction
- Project #OS482 – Spurlock Landfill, Area D, Phase 1 – (\$4,979,252) still under construction
- Project #OB424 – Cooper Inlet Hopper Discharge Modification with New System – (\$359,709) complete
- Project #OB428 – Cooper Treatment Plant pH Adjustment – (\$23,276) complete
- Project #OK046 – Smith CCR Groundwater Well - Purchase and Installation – (\$325,446) complete
- Project #OS442 – Spurlock CCR Groundwater Well - Purchase and Installation – (\$249,045) complete
- Project #OS521 – Spurlock Ash Haul Bridge Expansion Joint Plate Protectors – (\$342,996) complete
- Project #OS488 – Spurlock Backup Limestone Conveyor and TDF/Alternate Fuel Feeder – (\$2,646,723) complete
- Project #OS512 – Spurlock Fly Ash Silo Exhausters – (\$953,827) complete
- Project #OS487 – Spurlock Landfill - Area C Phase 5 – (\$5,083,982) complete
- Project #OS466 – Spurlock Units 1 and 2 Fly Ash Silo Dust Suppression System – (\$127,547) complete
- Project #OS465 – Spurlock Unit 4 Fly Ash Silo Dust Suppression System – (\$99,165) complete
- Project #OS460 – Spurlock Unit 2 Air Heater Deposition Measurement and Control System – (\$397,833) complete
- Project #OS516 – Spurlock Unit 1 Sonic Horns – (\$162,151) complete
- Project #OS469 – Spurlock Unit 2 Sonic Horns – (\$224,529) complete
- Project #OS470 – Spurlock Unit 3 Baghouse (Liner) – (\$5,465,071) complete
- Project #OS471 – Spurlock Unit 4 Baghouse (Liner) – (\$4,827,367) complete
- Project #OS511 – Spurlock Landfill - Haul Road Paving Phase 1 – (\$2,097,196) complete
- Project #OS474 – Spurlock Landfill, Area D, Ponds & Stream Mitigation – (\$10,889,612) complete

The foregoing is a true and exact copy of a resolution passed at a meeting called pursuant to proper notice at which a quorum was present and which now appears in the Minute Book of Proceedings

of the Board of Directors of the Cooperative, and said resolution has not been rescinded or modified.

Witness my hand and seal this 11th day of June, 2023.

A handwritten signature in black ink, appearing to read "Randy Sexton", written in a cursive style.

Randy Sexton, Secretary

Corporate Seal