

TIMBERLAND WWTF IN MCCRACKEN COUNTY, KENTUCKY

PERMIT ISSUE: _____, 2020
 CONSTRUCTION ISSUE: _____, 2020
 RECORD ISSUE: _____, 2020

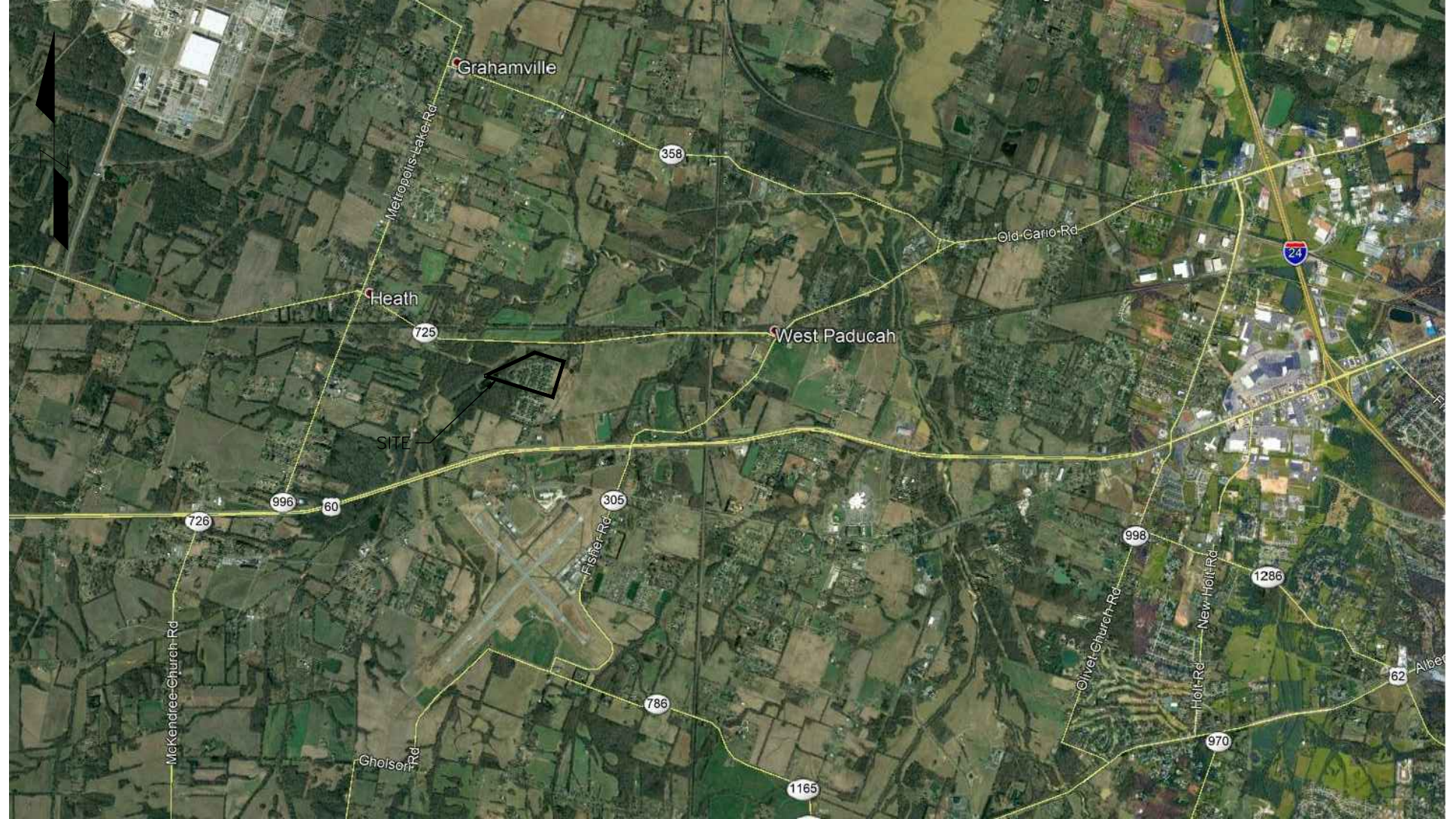

1351 Jefferson, Suite 301
 Washington, MO 63090
 mail@21designgroup.net
 P: 636-432-5029



VICINITY MAP

DRAWING LIST

- C01 TITLE
- C02 NOTES
- C03 EXISTING CONDITIONS / DEMOLITION PLAN
- C04 SITE / UTILITY PLAN
- C05 DETAILS
- P1 HYDRAULIC PROFILE
- P2 PROCESS FLOW DIAGRAM
- P3 PROCESS NOTES, ABBREVIATIONS AND LEGEND
- P4 PROCESS PLAN VIEW
- P5 CONTACT TANK NO. 2 AND OVERFLOW
STRUCTURE PLANS, SECTIONS AND DETAILS
- P6 AEROBIC DICESTER 1 AND 2 AND MBBR STAGE 1, 2,
AND 3 PLANS, SECTIONS AND DETAILS
- P7 CONTACT TANK NO. 1 CLARIFIER PLAN AND
BLOWER PLAN, SECTIONS AND DETAILS
- P8 PROCESS SECTIONS
- P9 PROCESS DETAILS AND ELECTRICAL RISER DIAGRAM



1351 Jefferson, Suite 301
 Washington, MO 63090
 mail@21designgroup.net
 P: 636-432-5029

COVER SHEET

TIMBERLAND WWTF
 TIMBERLAND DRIVE
 PADUCAH, KY

ENGINEERING CERTIFICATE OF
 AUTHORITY NO. 4804
 ENGINEERING LICENSE:
 BENJAMIN J. KUENZEL, PE33718



SEAL DATE: 2/15/2021

DRAWN BY: BJK

PROJ NUMBER: 542-B

DATE: 2/12/2021

DRAWING NO: C01

ALL RIGHTS RESERVED. All 21 Design Group, Inc., plans, specifications and drawings are protected under copyright law and no part may be copied, reproduced, displayed publicly, used to create derivatives, distributed, stored in a retrieval system or transmitted in any form by any means without prior written permission of 21 Design Group, Inc.

General Notes and Construction Specifications

- All water and sewer main construction shall be consistent with the local municipality requirements as well as all testing and disinfection requirements of Kentucky DEP.
- The contractor shall obtain, erect, maintain and remove all signs, barricades, flagmen and other control devices as may be necessary for the purpose of regulating, warning or guiding traffic. Placement and maintenance of all traffic control devices shall be in accordance with the latest revision of the Manual on Uniform Traffic Control Devices.
- Location of utilities shown on plans are approximate only, and are not necessarily complete. Contractor shall make his own investigations as to location of all existing underground structures, cables, utilities and pipe lines.
- If existing utility lines of any nature are encountered which conflict in location with new construction, the contractor shall notify the engineer and owner so that the conflict may be resolved.
- The contractor shall notify One Call at least 48 hours prior to construction so that each utility company can stake out any underground improvements that they may have which might interfere with the proposed construction.
- The contractor shall be required to make arrangements for the proper bracing, shoring and other required protection of all roadways, structures, poles, cables and pipe lines, before construction begins. He shall be responsible for any damage to the streets or roadways and associated structures and shall make repairs as necessary to the satisfaction of the engineer and owner at his own expense.
- The contractor shall be responsible for the protection of all private and public utilities even though they may not be shown on the plans. Any utility that is damaged during construction shall be repaired or replaced to the satisfaction of the engineer and owner by the contractor at his own expense.
- The contractor shall examine the plans and specifications, visit the site of the work and inform himself/herself fully with the work involved, general and local conditions, all federal, state and local laws, ordinances, rules and regulations and all other pertinent items which may affect the cost and time of completion of this project before submitting a proposal.
- All work and materials shall be in accordance with code requirements.
- Prior to submitting his bid, the contractor shall call the attention of the engineer to any material or equipment he deems inadequate and to any item of work omitted on the plans.
- Structures for valve vaults for water mains shall be in accordance with the improvement plans and the applicable municipality construction requirements. Where granular trench backfill is required around these structures, the cost shall be considered as incidental and shall be included in the contract unit price for the structure.
- Frame and cover or grates for water main structures shall be as indicated within these improvement plans.
- All final adjustments of casting will be accomplished by the use of precast concrete adjusting rings set in butyl rope joint sealant, mortar joints will not be allowed. Total height of adjusting rings used shall not exceed twelve (12") inches. cost for adjustment is considered incidental.
- The contractor shall be responsible to place on grade and coordinate with other contractors all underground structure frames such as catch basins, inlets, manholes, hydrants, buffalo boxes, valves, etc. No additional compensation shall be paid and said adjustments shall be considered incidental to other items of construction.
- The contractor shall restore any area disturbed to a condition equal to or better than its original use. This shall include finish grading, establishment of a vegetative cover (seeding or sod), general cleanup and pavement replacement.
- All trenches caused by the construction of all utilities and the excavation around catch basins, manholes, inlets and other appurtenances which occur within the limits of existing or proposed pavements, sidewalks and curb and gutters or where the edge of the trench shall be within two (2') feet horizontally of said improvements shall be backfilled with compacted granular trench backfill or with approved suitable select material and properly compacted to 100% of maximum density as determined by the standard proctor dry density (ASTM d 698) compaction test. When granular material is required, the cost shall be considered incidental and shall be included in the contractors bid.
- The depth of backfill shall be measured from the top of the pipe embedment to the finished subgrade or as noted on the plans.
- The contractor shall be responsible for providing safe and healthful working

- conditions throughout the construction of the proposed improvements.
- The engineer will be given forty-eight (48) hours notice for any staking that is to be done. The cost of stakeout is the responsibility of the contractor.
 - The contractor shall inform the engineer and owner before work commences on each category of construction, i.e. water main, grading, pavement and drainage improvement. A twenty-four (24) hour notice shall be given for any item that requires final testing and inspection such as water mains or sanitary sewers.
 - The engineer will furnish the contractor with lines and grades necessary to the proper prosecution and control of the work. The contractor shall call the attention of the engineer to any errors or discrepancies which may be suspected in lines and grades which are established by the engineer, and shall not proceed with the work until any lines and grades which are believed to be in error have been verified or corrected by the engineer or his representative.
 - All survey monuments damaged or removed during construction of this project shall be replaced by the surveyor and said cost of replacement shall be paid by the contractor.
 - The contractor will have in his possession on the job site a copy of the plans and specifications during construction.
 - If approval for any items is required, the contractor shall contact the engineer for approval prior to ordering.
 - Any drain and/or field tile encountered by the contractor during the installation of the improvements shall be returned to original condition. This work to be considered incidental to the contract.
 - All road signs, street signs and traffic signs which need to be relocated or moved due to construction shall be taken down and stored by the contractor at his own expense, except those which are necessary for proper traffic control which shall be temporarily reset until completion of construction operations. After completion of the work, the contractor shall reset, at his expense, all said signs.
 - The contractor shall dispose of all excess excavation, unsuitable and unusable materials offsite and at an approved location in a manner that public or private property will not be damaged or endangered. This work is considered as incidental to the cost of the project. Contractor to follow any local, state, and federal guidelines for disposing of material off site.
 - No trench excavations will be permitted to remain open over any weekend, night, or any time site is left unattended.
 - Band-seal style couplings shall be used when joining sewer pipes of dissimilar materials.
 - As-built drawings shall be prepared by the contractor and submitted to the engineer as soon as the site improvements are completed. Any change in length, location or alignment shall be shown in red. As-builts will be performed by a licensed surveyor. It will include the tops and flowlines of all storm and sanitary structures.
 - The contractor is responsible for coordinating any required inspections with the engineer and city or state agency.
 - Special attention is drawn to the fact that the standard specifications requires the contractor to have a competent superintendent on the project site at all times, irrespective of the amount of work sublet. The superintendent shall be capable of reading and understanding the plans and municipality construction specifications, shall have full authority to execute orders to expedite the project, shall be responsible for scheduling and have control of all work as the agent of the contractor. Failure to comply with this provision will result in a suspension of work as provided in the contract documents.
 - The engineer and owner are not responsible for the construction means, methods, techniques, sequences or procedures, time of performance, programs or for any safety precautions used by the contractor. The contractor is solely responsible for execution of his work in accordance with the contract documents and specifications.
 - The utilities shown hereon were plotted from available information and do not necessarily reflect the actual existence, non-existence, size, type, or location of these or other utilities. The contractor shall be responsible for verifying the actual location of all utilities. All utilities shall be located in the field prior to any construction of improvements. These provisions shall in no way absolve any party from complying with the underground facility safety and damage prevention act.
 - All materials and methods of construction to meet the specifications submitted for the construction permit.
 - Construction should not commence until all permits have been received from all

- governing agencies.
- No land disturbance activities can be completed until all land disturbance permitting has been acquired. It is the responsibility of the contractor to verify permits are in place prior to activities. Contractor will be responsible for any fines that are incurred due activities completed prior to having necessary permitting in place.
 - All fill material shall be made of selected earth materials, free from broken masonry, rock, frozen earth, rubbish, organic material and debris.
 - Grading contractor shall keep existing roadways clean of mud and debris at all times. If the city or owner has to clean the roads it will be at the expense of the contractor.
 - All graded areas shall be protected from erosion by erosion control devices and/or seeding and mulching as required by all local and state agencies and permits.
 - No grade shall exceed a 3:1 slope except where noted.
 - Interim stormwater drainage control in the form of siltation control measures are required.
 - Adequate temporary off-street parking shall be provided for construction employees. Parking on non-surfaced areas shall be prohibited in order to eliminate the condition whereby mud from construction and employee vehicles is tracked onto the pavement causing hazardous roadway and driving conditions.
 - The contractor shall, at all times, contain mud and other spoils on the site. No vehicle, trailer or construction equipment is to deposit mud or any other material on public streets. Project will be stopped if streets are not cleaned immediately.
 - Public roadways shall be kept open to traffic during all phases of construction of improvements. No driving lanes shall be closed without prior written permission from the governing agency.
 - The contractor shall furnish, maintain, and remove traffic control devices for the purpose of regulating, warning, and directing traffic during construction in the public roadways. All flagmen, barricades, warning signs, etc. shall conform to the manual for uniform traffic control devices.
 - No investigation has been performed by the engineer regarding hazardous waste, underground conditions or utilities affecting the tract of land shown herein.
 - This plan is not a survey in any sort and shall not constitute a boundary survey.
 - Onsite utilities have been shown based on documents obtained from public entities.
 - See MEP/Arch. plans for site lighting and electrical design/layout.
 - Contractor shall comply with all OSHA requirements for safety and construction.
 - All utility trenches in paved areas shall be compacted to the requirements of the specific paving specification. Only granular material shall be used in utility trenches under paved areas.
 - All unsurfaced areas shall receive a minimum of 6" of topsoil. Contractor shall seed, fertilize, mulch, and maintain all disturbed areas until stabilization is provided meeting the technical specifications and/or direction of the Engineer.
 - The contractor is responsible for maintenance of sediment control bmps throughout the entire project.
 - All sewer laterals shall have a 2% minimum slope.
 - All storm sewer covers shall have the words "Storm Drain" cast in the top in letters three inches high. All sanitary sewer covers shall have "Sanitary Sewer" meeting same specification.
 - All frames, grates and covers shall be ductile iron, conforming to ASTM A48, Class 30 and shall be designed for heavy duty traffic.
 - Manhole steps shall be constructed of polypropylene conforming to ASTM D 4101 and shall meet current state and federal safety standards. Steps shall be Neenah R-1981-N or approved equal.
 - Pre-cast manholes shall be at least 48" diameter and conform with ASTM C478 and to design dimensions. All lift hole shall be thoroughly wetted and completed filled with mortar and smoothed. Structures shall be free of fractures or cracks.

- All joints between pre-cast elements on manholes shall be made with an approved bitumastic material or an approved rubber gasket. Contractor shall submit shop drawings to engineer for approval prior to ordering.
- All storm sewer 12" to 30" in diameter shall be Corrugated Polyethylene Pipe (CPP) or High Density Polypropylene (HDPP).
 - CPP pipe and fittings shall conform to ASTM F405 and F667 and shall have a circular cross-section and have a smooth wall interior.
 - End sections shall be polyethylene flared type with toe plates.
 - Joints shall be provided with neoprene or manufacturer's standard gaskets and meet ASTM F2881. Pipes up to shall be water tight according to D3212. Spigots shall have gaskets meeting the requirements of ASTM F477.
 - All CPP or HDPP shall be installed using embedment material meeting North Carolina Department of Transportation requirements.
 - Installation to conform to ASTM D2321 and pipe manufacturer's recommendations for backfill, bedding, installation, and minimum cover requirements.
 - Clean joints thoroughly, and coat bell, spigot and gasket with recommended lubricant before jointing.
 - Dual wall and triple wall polypropylene pipe (HDPP) shall conform to the requirements of AASHTO M330 "Standard Specification for Polypropylene Pipe, ASTM F2736 (Dual wall) for sizes 12" to 30" and ASTM F2764 (Triple wall) for sizes 30" to 60". All polypropylene pipe shall be installed according with ASTM F2321 "Standard Practice for Underground Installation of Thermoplastic Pipe for Sewers and Other Gravity-Flow Applications."



1351 Jefferson, Suite 301
Washington, MO 63090
Phone: 636-452-8229
mail@designgroup.net

GENERAL NOTES

TIMBERLAND WHITE
TIMBERLAND DRIVE
PADUCAH, KY

ENGINEERING CERTIFICATE OF AUTHORITY NO. 4804
ENGINEERING LICENSE: BENJAMIN J. KUENZEL, PE33718

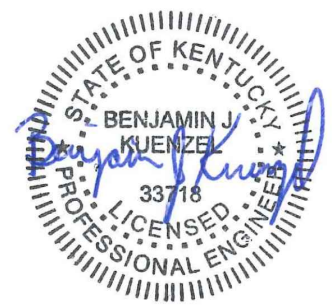

SEAL DATE: 2/15/2021
DRAWN BY: BJK
PROJ NUMBER: 542-B
DATE: 2/12/2021

DRAWING NO: C02

ALL RIGHTS RESERVED. All "21 Design Group, Inc." plans, specifications and drawings are protected under copyright law and no part may be copied, reproduced, displayed publicly, used to create derivatives, distributed, stored in a retrieval system or transmitted in any form by any means without prior written permission of "21 Design Group, Inc."

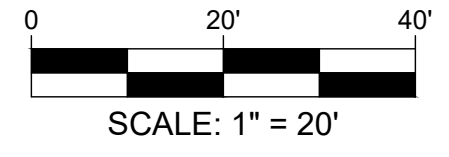
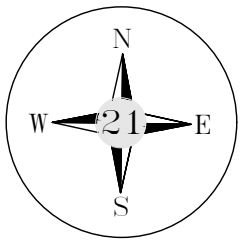

DRAWING LEGEND

Asphalt	
Concrete	
Easement	
Setbacks	
Property Lines	
Sanitary Sewer	
Gas Main	
Water Main	
Underground Telephone	
Aerial Electric	
Underground Electric	
Storm Sewer	
Contours	
Tree Line	
Sanitary Manhole	
Utility Pole	
Fire Hydrant	
Telephone Box	
Water Valve	
Gas Valve	
Sign	
Grated Inlet	
Catch Basin	
Grated Curb Inlet	
Junction Box	
Flared End Section	



- NOTE:
1. CONTRACTOR SHALL VISIT SITE PRIOR TO SUBMITTING BID TO EVALUATE SITE CONSTRAINTS. THIS SHALL INCLUDE BUT NOT LIMITED TO LOCATION OF POWER LINES IN RESPECT TO THE SITE.
 2. AT ALL TIMES, INCOMING SEWAGE SHALL BE TREATED BY THE EXISTING FACILITY OR NEW FACILITY. AT NO POINT SHALL THE CONTRACTOR BYPASS TREATMENT AND ALLOW WASTEWATER TO DISCHARGE DIRECTLY INTO THE RECEIVING STREAM.

DATE	1/27/2021	PERSON	PERMIT SET
A			

21 DESIGN GROUP INC.
 1351 Jefferson, Suite 301
 Washington, MO 63090
 Phone: 636-452-5227
 Email: mail@21designgroup.net

EXISTING CONDITIONS / DEMOLITION PLAN

TIMBERLAND WWTF
 TIMBERLAND DRIVE
 PADUCAH, KY

ENGINEERING CERTIFICATE OF AUTHORITY NO. 4804
 ENGINEERING LICENSE: BENJAMIN J. KUENZEL, PE33718

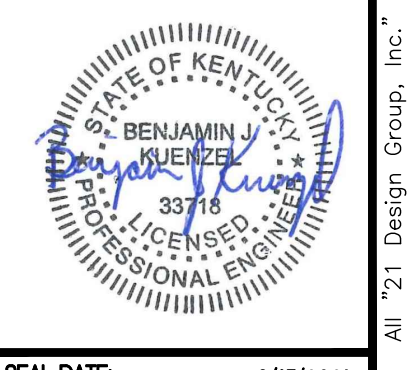

SEAL DATE	2/15/2021
DRAWN BY	BJK
PROJ NUMBER	542-19
DATE	2/12/2021
DRAWING NO.	C03

ALL RIGHTS RESERVED. All 21 Design Group, Inc., plans, specifications and drawings are protected under copyright law and no part may be copied, reproduced, displayed publicly, used to create derivatives, distributed, stored in a retrieval system or transmitted in any form by any means without prior written permission of 21 Design Group, Inc.

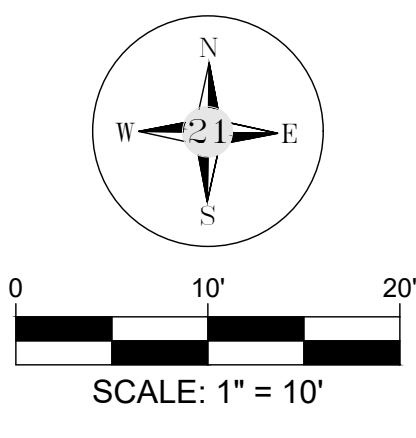

DRAWING LEGEND

DESCRIPTION	EXISTING	PROPOSED
Easement	---	---
Setbacks	---	---
Property Lines	---	---
Aerial Electric	AE	AE
Tree Line	~~~~~	~~~~~
Sanitary Manhole		
Utility Pole		
Fire Hydrant		
Telephone Box		
Water Valve		
Gas Valve		
Sign		
Grated Inlet		
Catch Basin		
Grated Curb Inlet		
Junction Box		
Flared End Section		

PAVEMENT LEGEND

Existing Asphalt	
Existing Concrete	
New Concrete	
New Standard Duty Asphalt	
New Heavy Duty Asphalt	
New Standard Duty Concrete	
New Heavy Duty Concrete	

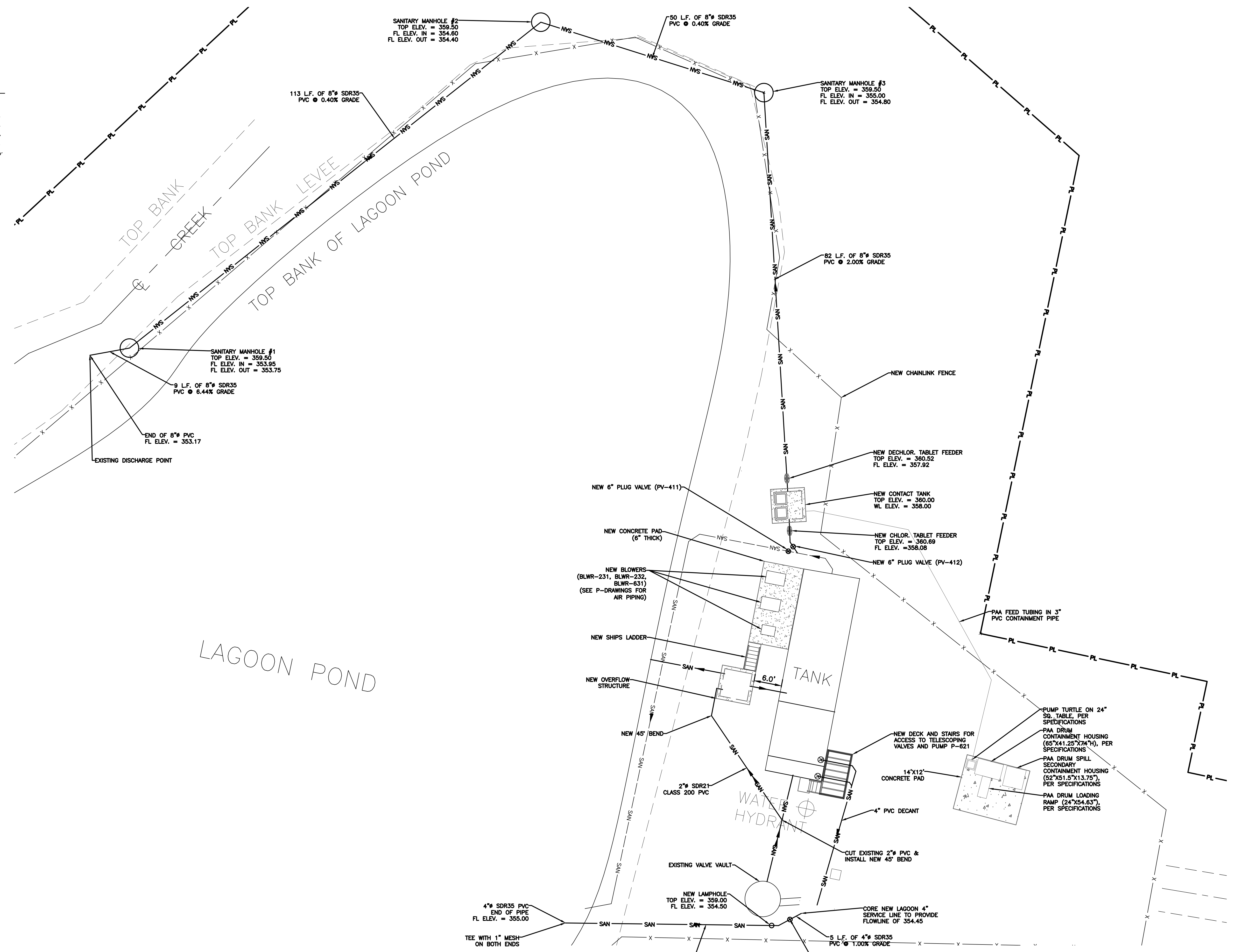

NOTE:
 1. SEE HYDRAULIC PROFILE FOR ALL ELEVATIONS.
 2. SEE DRAWING P4 FOR ALL AIR PIPING DETAILS.

REV	DATE	PERSON	PERMIT SET
A	12/27/2021		

21 DESIGN GROUP INC.
 1351 Jefferson, Suite 301
 Washington, MO 63090
 mail@21designgroup.net
 P: 636-452-8229

SITE/UTILITY PLAN
 TIMBERLAND WWTF
 TIMBERLAND DRIVE
 PADUCAH, KY

ENGINEERING CERTIFICATE OF AUTHORITY NO. 4804
 ENGINEERING LICENSE: BENJAMIN J. KUENZEL, PE33718

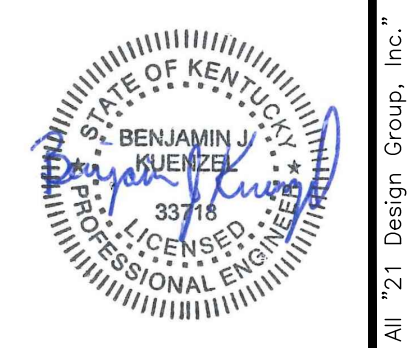

SEAL DATE	2/15/2021
DRAWN BY	BJK
PROJ NUMBER	542-9
DATE	2/12/2021
DRAWING NO	C04

ALL RIGHTS RESERVED. All 21 Design Group, Inc., plans, specifications and drawings are protected under copyright law and no part may be copied, reproduced, displayed publicly, used to create derivatives, distributed, stored in a retrieval system or transmitted in any form by any means without prior written permission of "21 Design Group, Inc."

- NOTES:**
1. PORTLAND CEMENT CONCRETE SHALL COMPLY WITH CURRENT DOT STANDARD SPECIFICATIONS FOR ROAD AND BRIDGE CONSTRUCTION. CONCRETE SHALL HAVE A 28-DAY COMPRESSIVE STRENGTH OF 4,000 PSI, AIR ENTRAINMENT OF 5 TO 7 PERCENT, AND SLUMP BETWEEN 1 TO 3 INCHES.
 2. SUBGRADE SHALL BE COMPACTED TO A DENSITY OF NO LESS THAN 95% OF STANDARD PROCTOR (PER ASTM D-698)
 3. SEE GEOTECHNICAL REPORT FOR PAVEMENT SPECIFICATION REQUIREMENTS.
 4. MAXIMUM JOINT SPACING SHALL BE 24 TIMES THE CONCRETE THICKNESS WITH SLABS BE NO GREATER THAN 2:1 LENGTH TO WIDTH.
 5. NON-REINFORCED CONCRETE PAVING, CONTRACTOR TO USE SMOOTH DOWELS AT CONSTRUCTION JOINTS.
 6. SEE GEOTECHNICAL REPORT FOR ALL COMPACTION, POURING, AND MATERIAL REQUIREMENTS. IF A CONFLICT EXISTS, THE GEOTECHNICAL REPORT GOVERNS.
 7. PROOF ROLL SUBGRADE DOUBLE TANDOM AXLE TRUCK PRIOR TO PLACING ROCK BASE MATERIAL.
 8. CONCRETE CURING SHALL BE PROVIDED PER ASTM C-309 OR MODOT SPECIFICATIONS, WHICHEVER IS GREATER.
 9. JOINT SEALER PER MODOT SPECIFICATIONS.
 10. WEATHER PROVISIONS SHALL COMPLY TO MODOT STANDARD CONSTRUCTION REQUIREMENTS.

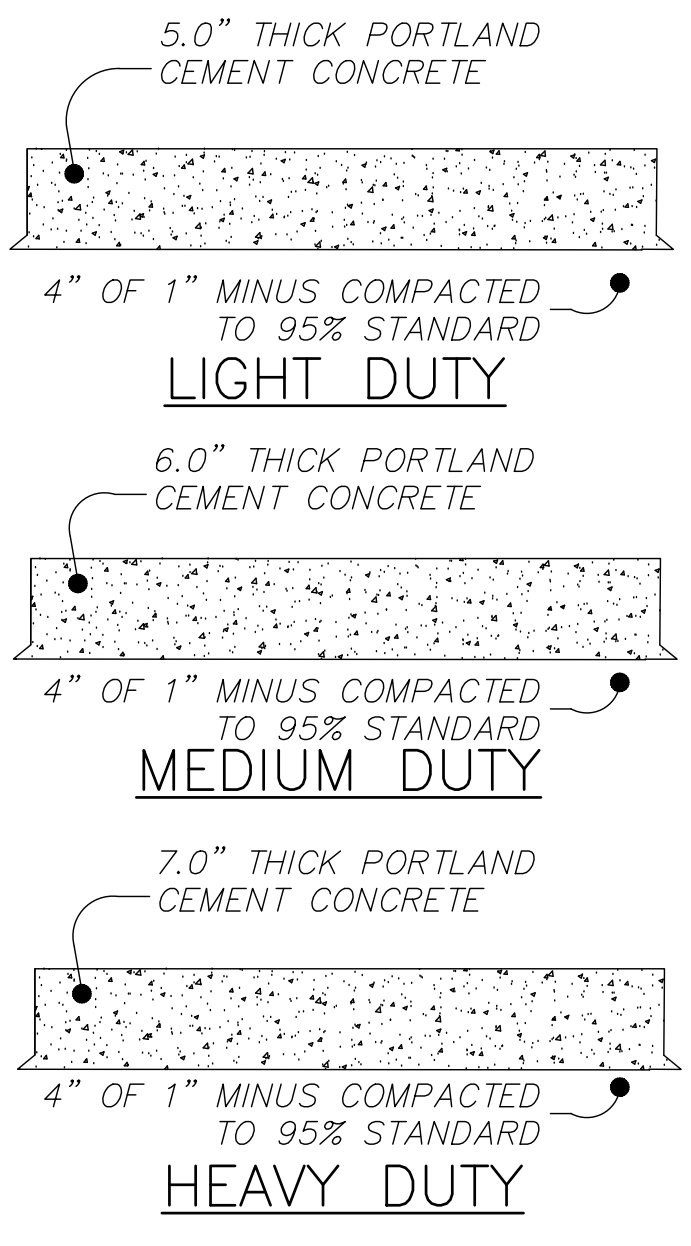

CONCRETE SECTION DETAILS
Not To Scale

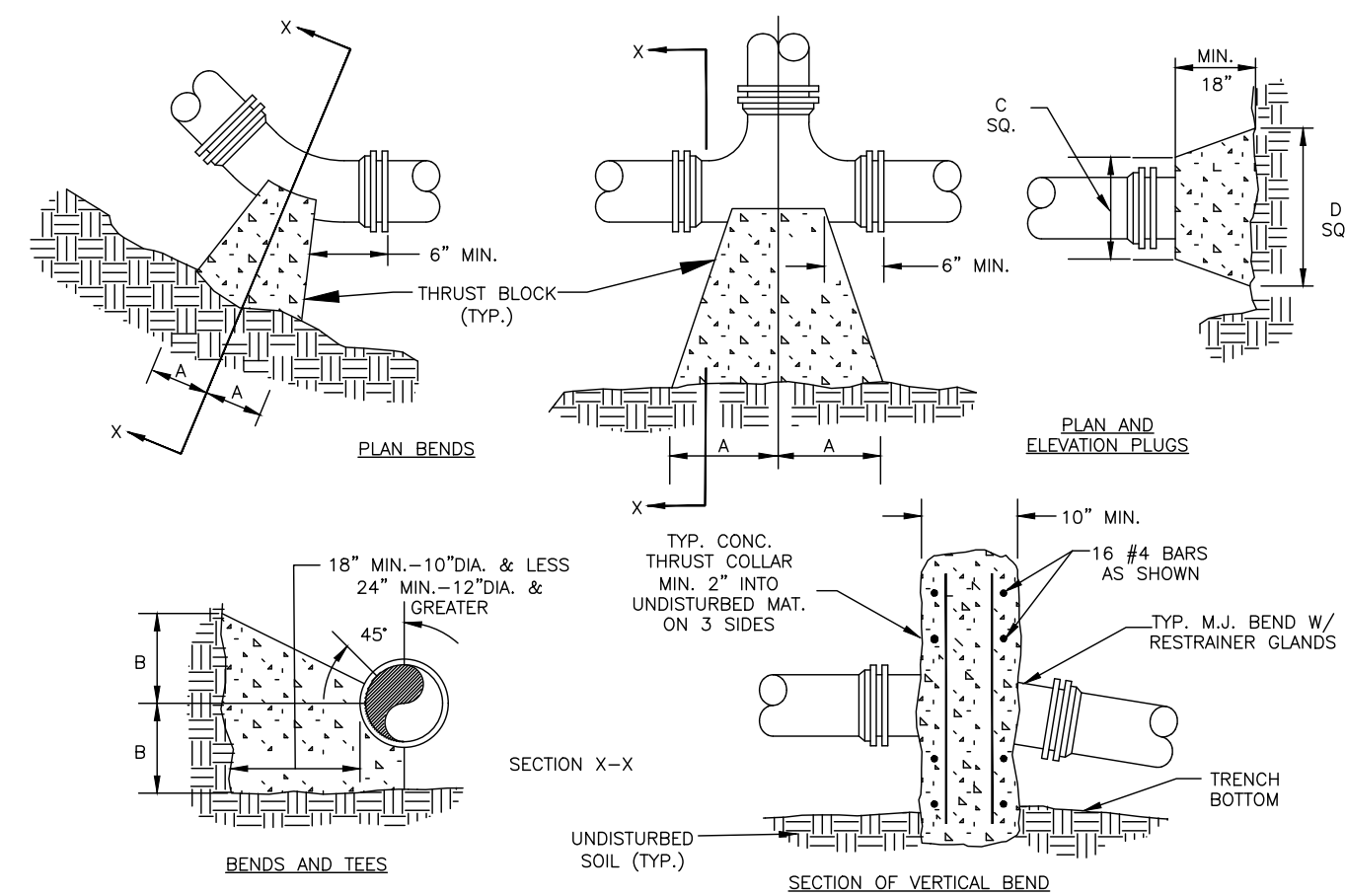

- NOTES:**
1. FOR VERT. BEND DOWN IN EXCESS OF 11 1/4" BEND, ANCHORAGE SHALL BE DESIGNED BY ENGINEER.
 2. FOR VERT. BEND UPWARD, BLOCKING TO BE SIMILAR TO THAT FOR HORIZ. BEND.
 3. GLANDS & BOLTS SHALL BE PROTECTED FROM CONC. BY PLASTIC SHEETING WHEN POURING THRUST BLOCKS.
 4. ALL THRUST BLOCK & SUPPORT CONC. SHALL BE 3000 PSI READY MIX CONC.
 5. THRUST BLOCKS WITH "8" DIMENSION GREATER THAN 30" SHALL HAVE THE RESTRAINED PIPE INSTALLED WITH A MINIMUM OF 4" OF COVER.

PIPE SIZE	90° BEND		45° BEND		22 1/2° BEND			11 1/4° BEND				TEE		PLUG	
	A	B	A	B	A	B	C	A	B	C	D	A	B	C	D
4"	8"	12"	8"	8"	6"	6"	6"	6"	11"	9"	10"	6"			
6"	18"	12"	8"	10"	8"	8"	8"	8"	11"	10"	12"	18"			
8"	18"	13"	10"	10"	8"	8"	8"	8"	11"	12"	12"	24"			
10"	20"	16"	12"	14"	8"	12"	8"	12"	14"	16"	16"	30"			
12"	20"	16"	12"	14"	8"	12"	8"	12"	14"	16"	16"	30"			
16"	26"	20"	16"	18"	11"	13"	11"	13"	18"	20"	20"	36"			
24"	82"	42"	62"	30"	44"	22"	22"	16"	82"	42"	82"	42"			
30"	185"	42"	100"	42"	52"	42"	40"	30"	185"	42"	185"	42"			

THRUST BLOCK CONSTRUCTION
Not To Scale

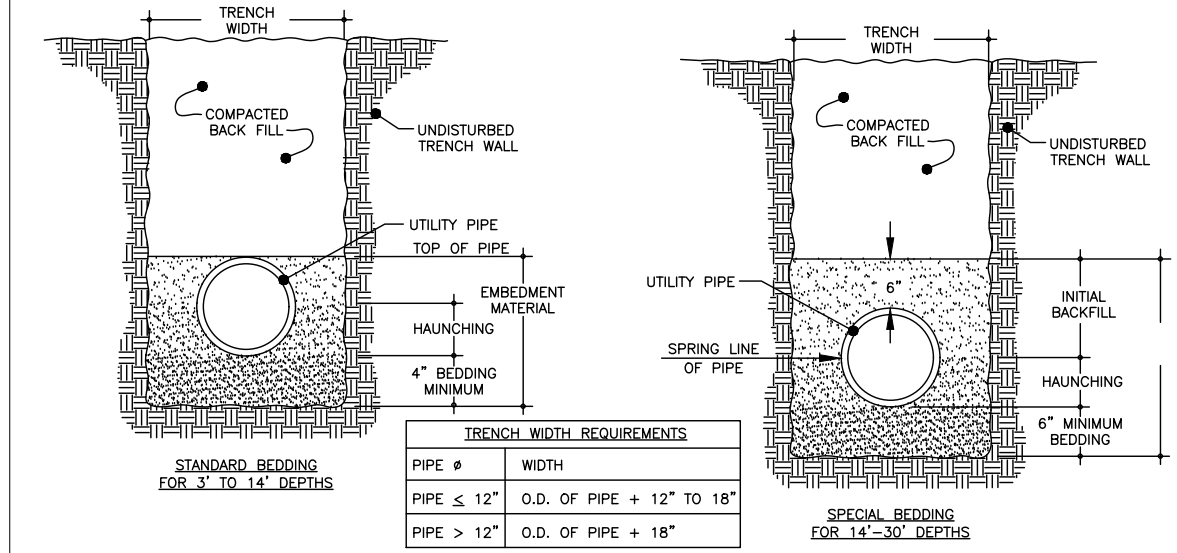

- NOTES:**
1. EMBEDMENT MATERIAL MUST BE 1" MINUS GRANULAR BACKFILL.
 2. EMBEDMENT MATERIAL SHALL BE COMPACTED TO A MINIMUM 95% STANDARD PROCTOR DENSITY.
 3. STANDARD BEDDING SHALL BE UTILIZED FOR ALL CASES WHERE TRENCH BOTTOMS ARE UNSTABLE DUE TO SOIL TYPE OR MOISTURE CONDITIONS.
 4. TRENCH EXCAVATION SHALL CONFORM TO ALL OSHA CONSTRUCTION REQUIREMENTS.
 5. ANY TRENCHING UNDER PAVED AREAS SHALL BE BACKFILLED WITH 1" MINUS AND COMPACTED TO 95% STANDARD PROCTOR DENSITY.
 6. CONTRACTOR IS RESPONSIBLE FOR TRENCH SETTLEMENT.
 7. IN AREAS OF ROCK CUT, TRENCHES SHALL BE BACKFILLED WITH WELL GRADED GRANULAR MATERIAL TO 6" ABOVE THE TOP OF PIPE.
 8. ALL UTILITY INSTALLATION SHALL CONFORM TO THE PIPE MANUFACTURER.
 9. HAUNGING SHALL BE WORKED AROUND THE PIPE BY HAND TO ELIMINATE ALL VOIDS.

TRENCH WIDTH REQUIREMENTS		TRENCH DEPTH REQUIREMENTS	
PIPE Ø	WIDTH	UTILITY	MIN. DEPTH
PIPE ≤ 12"	O.D. OF PIPE + 12" TO 18"	GAS	SEE UTILITY CO.
PIPE > 12"	O.D. OF PIPE + 18"	WATER	42"
		ELECTRIC	24"
		SANITARY	36"

PIPE REQUIREMENTS			
UTILITY	Ø 12" TO 18"	16" TO 30"	> 30"
GAS	SEE UTILITY COMPANY		
WATER	DUCTILE	CLASS 200	DUCTILE
ELECTRIC	PVC	PVC	N/A
STORM	CONCRETE	HDPE	CONCRETE
SANITARY	DUCTILE	CLASS 200	DUCTILE

UTILITY TRENCHING & BEDDING DETAIL
Not To Scale

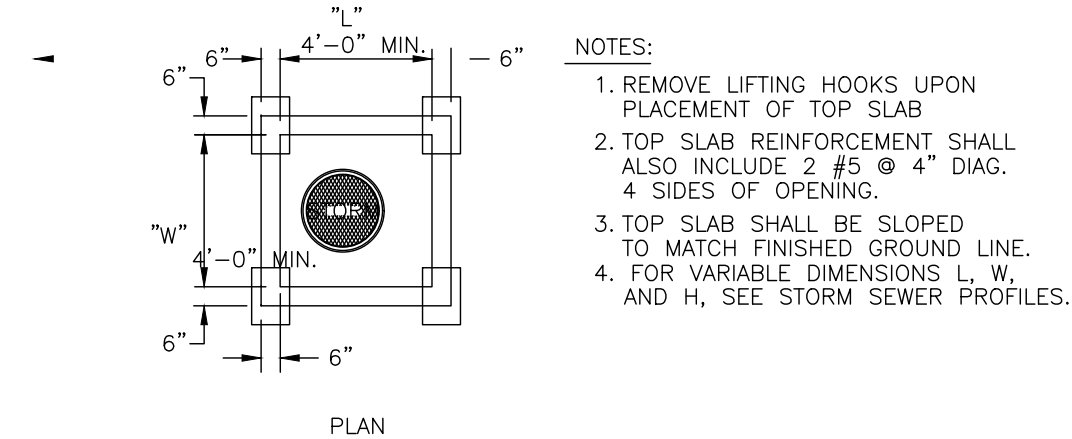

- NOTES:**
1. REMOVE LIFTING HOOKS UPON PLACEMENT OF TOP SLAB
 2. TOP SLAB REINFORCEMENT SHALL ALSO INCLUDE 2 #5 @ 4" DIAG. 4 SIDES OF OPENING.
 3. TOP SLAB SHALL BE SLOPED TO MATCH FINISHED GROUND LINE.
 4. FOR VARIABLE DIMENSIONS L, W, AND H, SEE STORM SEWER PROFILES.

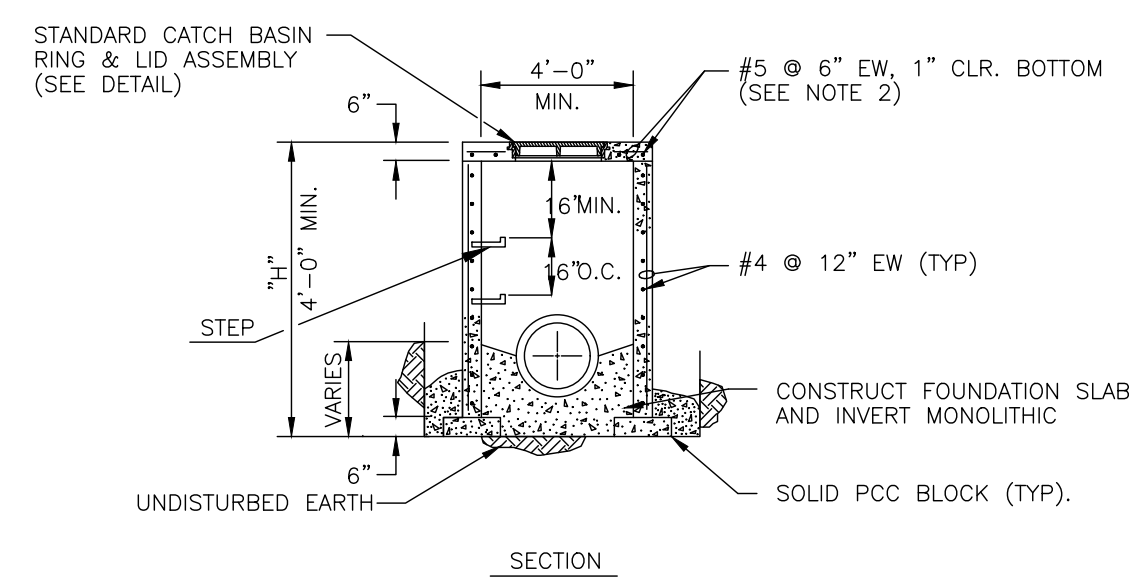

STORM MANHOLE DETAIL
Not To Scale

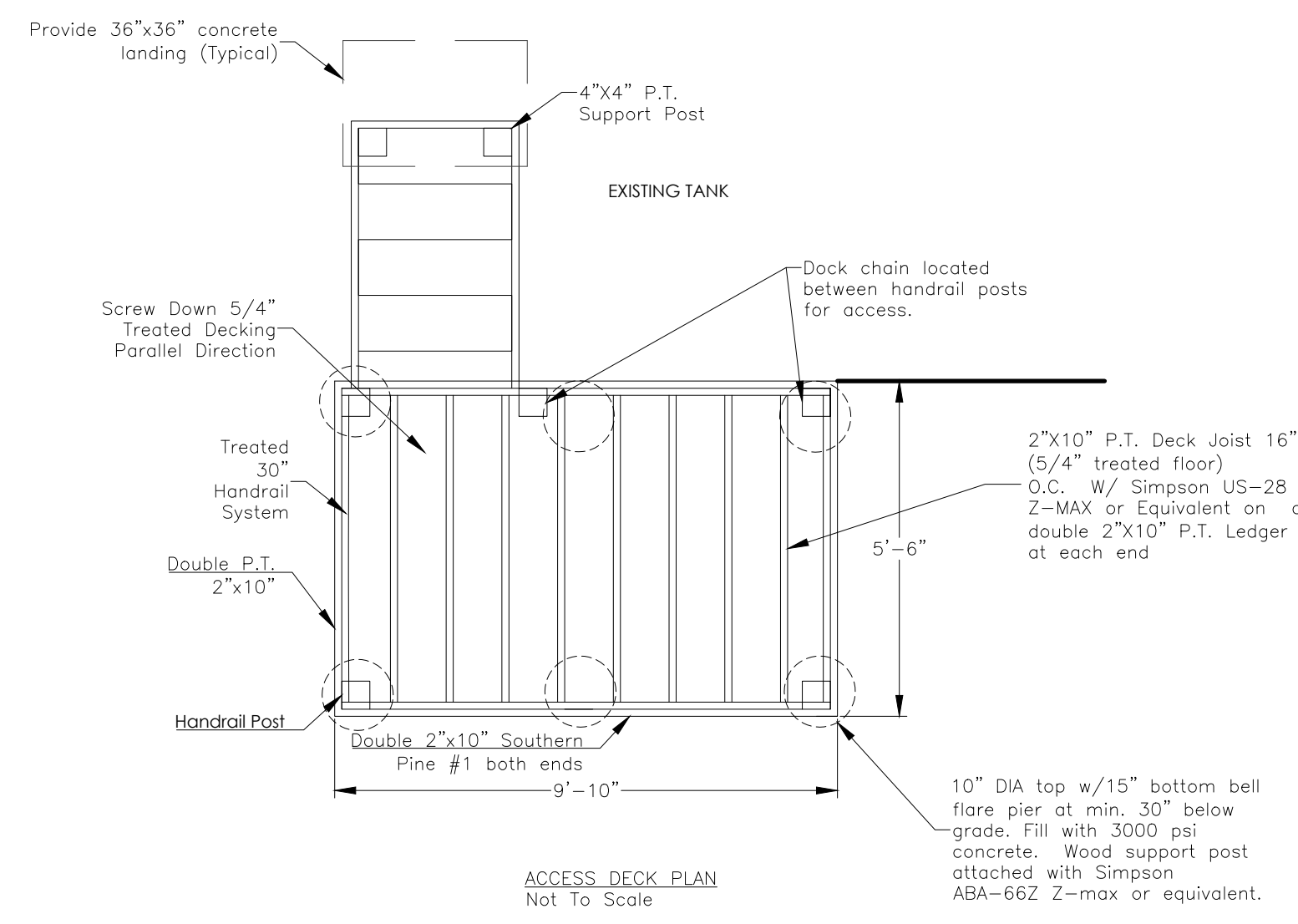

ACCESS DECK PLAN
Not To Scale

Sanitary PROFILE

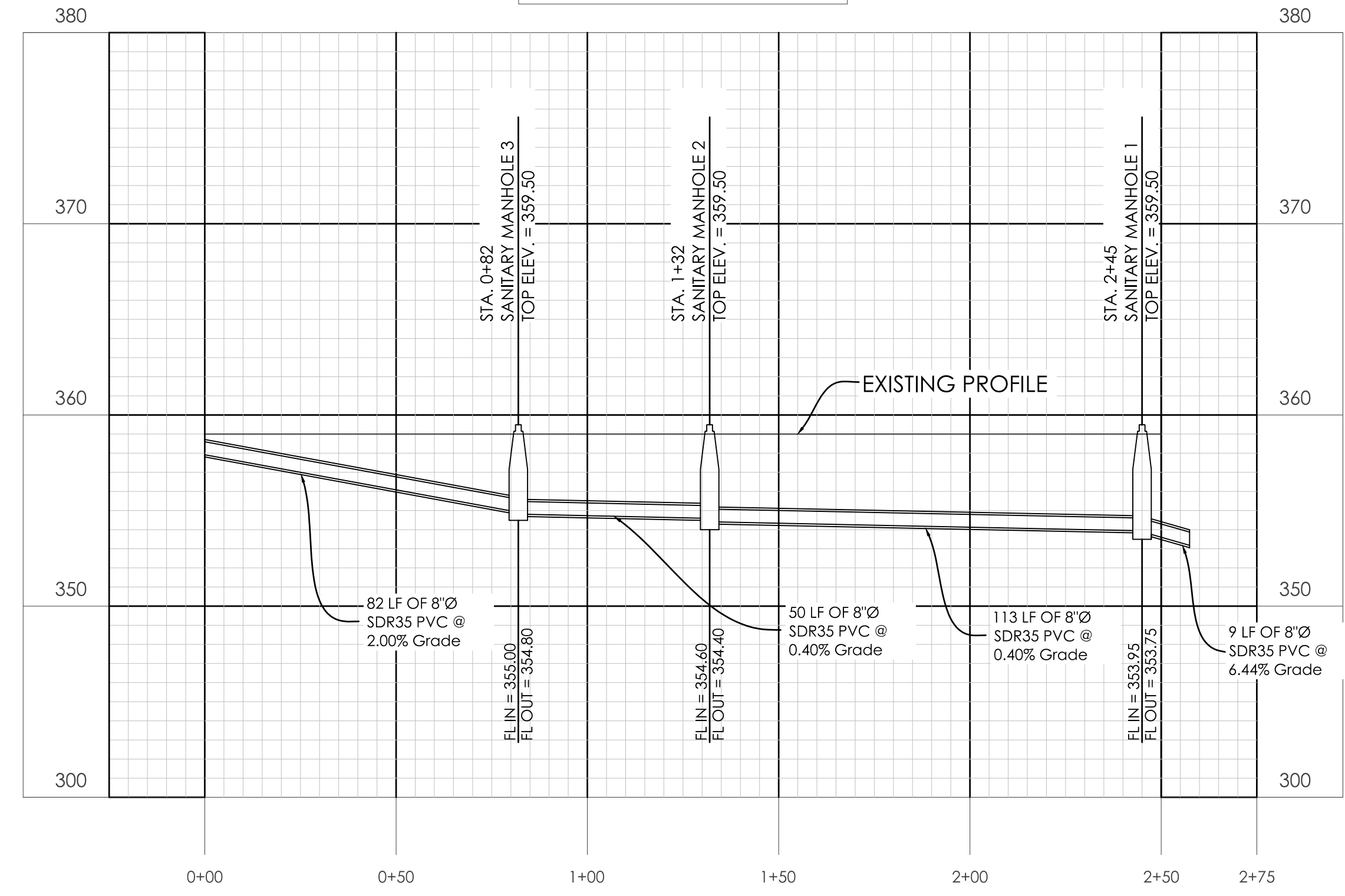

EFFLUENT SANITARY SEWER PROFILE

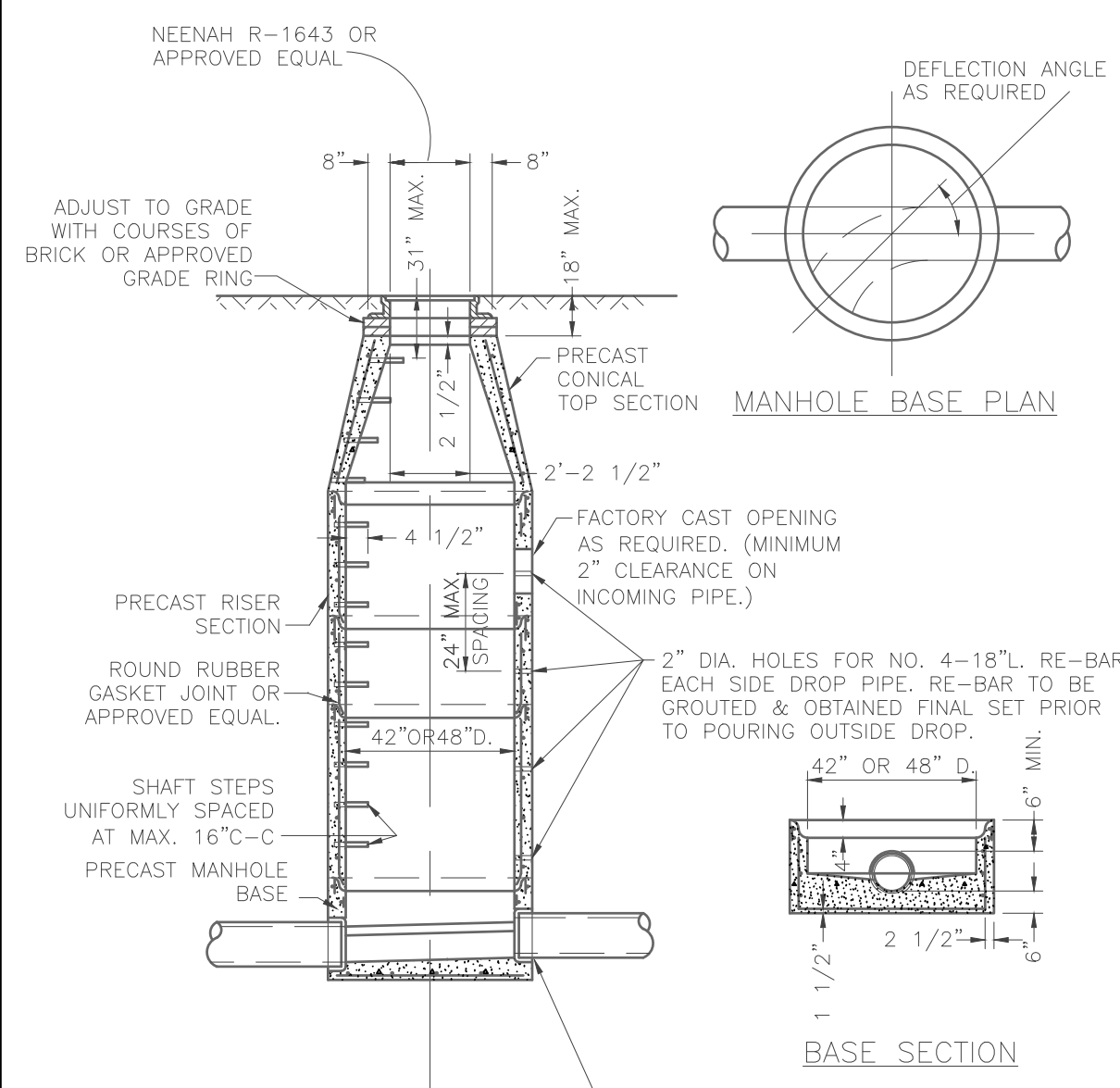

PRE-CAST CONCRETE MANHOLE FOR SEWERS 8" THROUGH 18"
Not To Scale

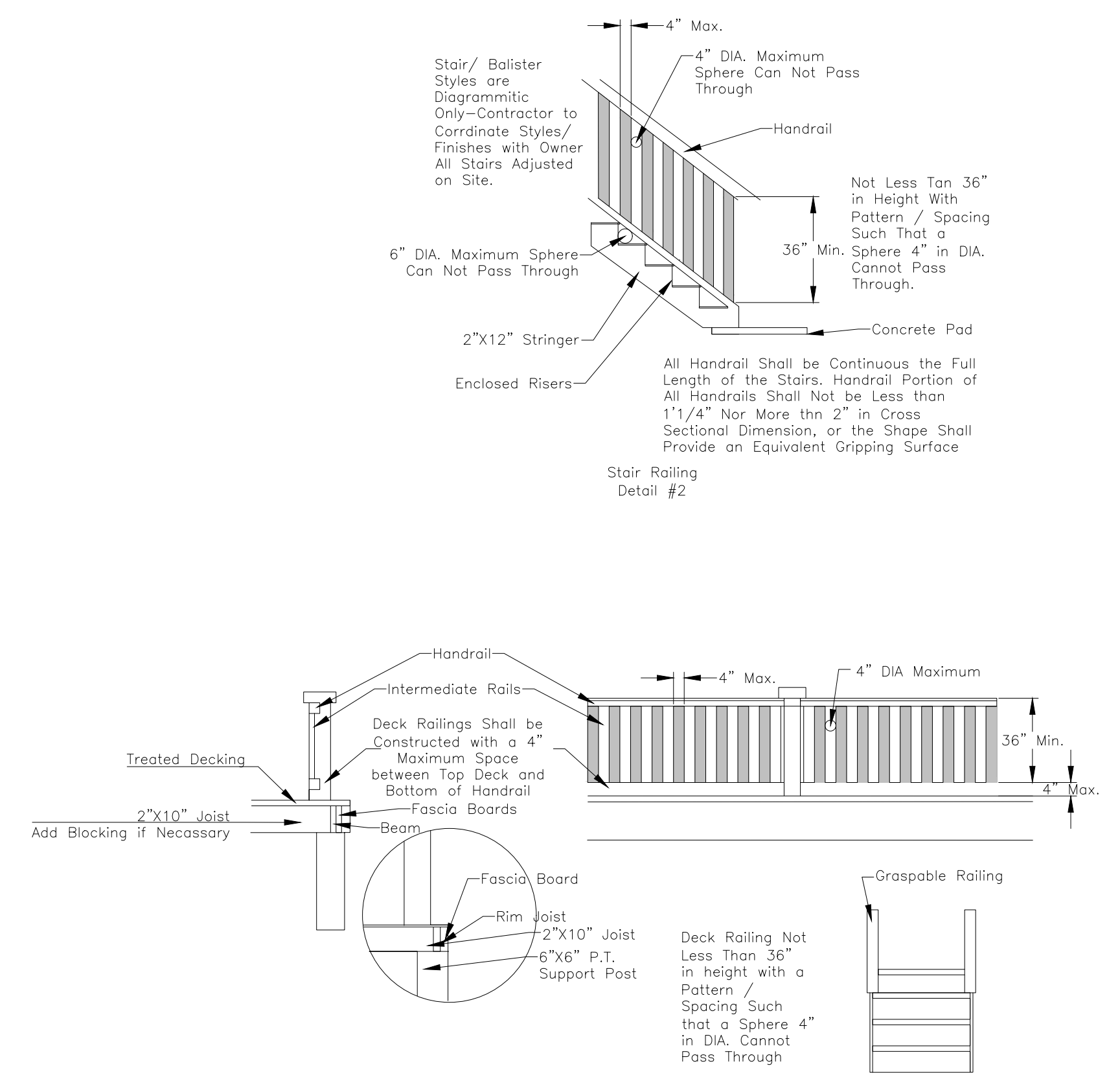

WOOD DECK AND STAIR DETAIL (TVL-681,682 AND P-621 ACCESS PLATFORM)
Deck and Railing Detail Handrail Support Post Detail #1

21 DESIGN GROUP INC.
mail@21designgroup.net
1351 Jefferson, Suite 301
Washington, MO 63090
P: 636-452-8227

DETAIL SHEET
TIMBERLAND WHITE
TIMBERLAND DRIVE
PADUCAH, KY

ENGINEERING CERTIFICATE OF AUTHORITY NO. 4804
ENGINEERING LICENSE: BENJAMIN J. KUENZEL, PE33718

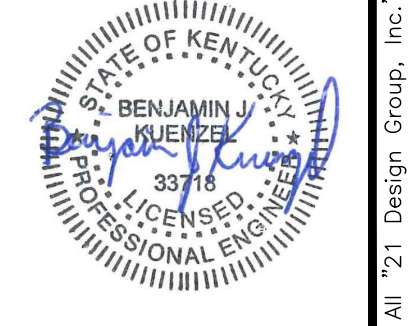

SEAL DATE: 2/15/2021
DRAWN BY: BJK
PROJ NUMBER: 542-9
DATE: 2/12/2021
DRAWING NO: C05

ALL RIGHTS RESERVED. All 21 Design Group, Inc., plans, specifications and drawings are protected under copyright law and no part may be copied, reproduced, displayed publicly, used to create derivatives, distributed, stored in a retrieval system or transmitted in any form by any means without prior written permission of 21 Design Group, Inc.

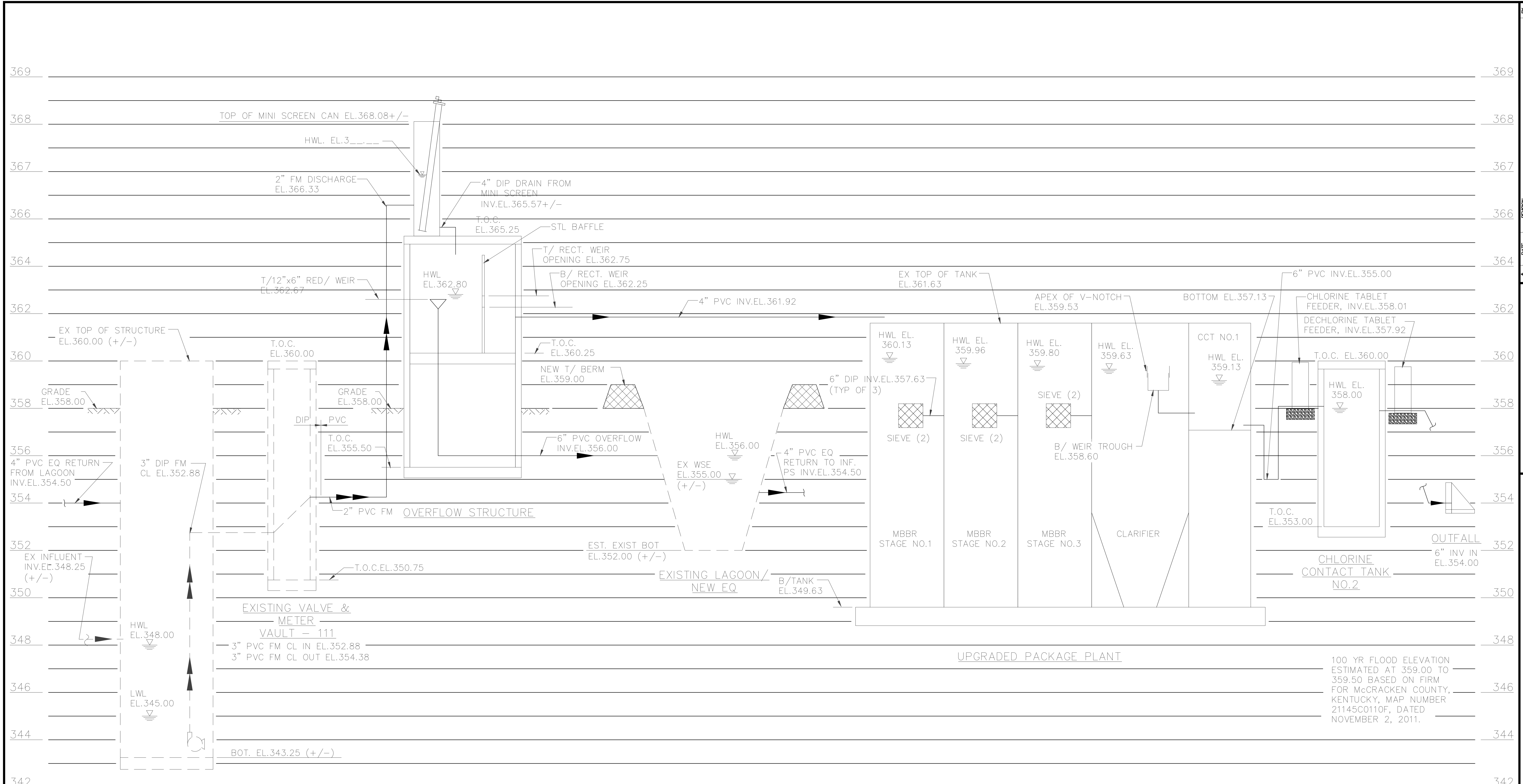

REV	DATE	DESCRIPTION
A	12/23/2020	PERMIT SET

DESIGN GROUP INC.

1351 Jeffersonville, Suite 301
Washington, MO 63090
mail@designgroup.net
734-492-2622

HYDRAULIC PROFILE

TIMBERLAND WWTF
6500 US 60 WEST
PADUCAH, KY

100 YR FLOOD ELEVATION ESTIMATED AT 359.00 TO 359.50 BASED ON FIRM FOR McCracken COUNTY, KENTUCKY, MAP NUMBER 21145C0110F, DATED NOVEMBER 2, 2011.

HYDRAULIC PROFILE

ENGINEERING CERTIFICATE OF AUTHORITY NO. 4808
ENGINEERING LICENSE: BENJAMIN J. KUENZEL, PE33718

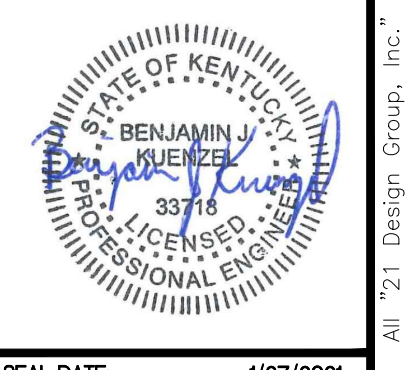

SEAL DATE: 1/27/2021
DRAWN BY: DDG
PROJ NUMBER: 0542-19
DATE: 12/23/2020
DRAWING NO: P1

ALL RIGHTS RESERVED. All 21 Design Group, Inc., plans, specifications and drawings are protected under copyright law and no part may be copied, reproduced, displayed publicly, used to create derivatives, distributed, stored in a retrieval system or transmitted in any form by any means without prior written permission of 21 Design Group, Inc.

DESIGN CRITERIA:

RAW INFLUENT FLOW AND INFLUENT PUMP STATION
 ADF Q = 25,000 GPD
 PDF Q = 75,000 GPD
 PHF Q = 100,000 GPD

MBBR INFLUENT FLOW (DOWNSTREAM EQUALIZATION)
 25,000 GPD
 50,000 GPD
 50,000 GPD

EXISTING INFLUENT PUMP STATION
 DIMENSIONS: 4' DIA x 3' OPERATING RANGE
 P-111 - 69.4 GPM @ 17 FT TDH
 P-112 - 69.4 GPM @ 17 FT TDH

MBBRS
 DIMENSIONS: (3) EA OF 6'x11.25'x10.17' (AVG WATER DEPTH)
 TOTAL VOLUME: 15,400 GAL.
 HRT @ ADF: 14.8 HRS
 HRT @ PDF: 7.4 HRS
 MEDIA FILL: 30%
 TOTAL SURF AREA: 8,745 M₂

CLARIFIERS:
 DIMENSIONS: (2) EA OF 5.5'x7.7'x10' WATER DEPTH
 SURFACE AREA: 85 SQ SF
 SOR @ PDF: 590 GPD/SF
 SOR @ PHF: 590 GPD/SF
 WEIR LENGTH: 22.3 FT.
 WEIR OVERFLOW RATE: @ PHF: 2,239 GPD/FT.

PAA FEED PUMP
 MINIMUM PUMPING CAPACITY FOR 5 PPM AS PAA (0.032 GPH)
 PUMP CAPACITY PROPOSED: 15.1 GPD
 W/PERISTALTIC PUMP

OVERFLOW STRUCTURE
 DIMENSIONS: 6'x6'x7'
 MBBR INFLUENT RECTANGULAR WEIR 3" WIDE, INV. EL.362.75, TOP OF OPENING EL.363.25.
 OVERFLOW WEIR (TO LAGOON) AT EL.363.17

AEROBIC DIGESTER NO.1
 DIMENSIONS: 12'x11.25'x10.33' (HWL)
 TOTAL VOLUME: 10,431 GAL.
 VOL/POP. EQ.: 6.6 CF/PE
 EST. SRT.: 70 DAYS
 SCFM: 42 SCFM (AT 30 SCFM/1,000 CF)

EXISTING CONTACT TANK NO.1
 DIMENSIONS: 3'x11.25'x3.17' (HWL)
 TOTAL VOLUME: 800 GAL.
 HRT: 23 MINUTES
 CT NO.1 TO BE USED AS BACKUP.

PAA STORAGE
 STORE W/110 GAL: 343.8 DAYS
 ESTIMATED (ASSUMES 2 PPM AS PAA OR 12.8 PPM AS PROXITANE IS REQUIRED DOSAGE).
 SECONDARY CONTAINMENT VOLUME: 198 GAL.

AEROBIC DIGESTER NO.2
 DIMENSIONS: 3.25'x11.25'x10.17' (HWL)
 TOTAL VOLUME: 2,825 GAL.
 VOL/POP. EQ.: 1.8 CF/PE
 EST. SRT.: 41 DAYS
 SCFM: 11 SCFM (AT 30 SCFM/1,000 CF)

NEW CONTACT TANK NO.2/ POST-AERATION
 DIMENSIONS: 6'x6'x5' (HWL)
 TOTAL VOLUME: 1,346 GAL.
 HRT: 39 MINUTES
 CT NO.2 USED FOR POST-AERATION/PEROXYACETIC ACID DISINFECTION
 CHLORINE AND DECHLORINATION TABLET FEEDERS TO BE USED FOR BACKUP DISINFECTION ONLY
 AIR FLOW RATE: 20 SCFM/1,000 CF
 SCFM PROVIDED: 4 SCFM

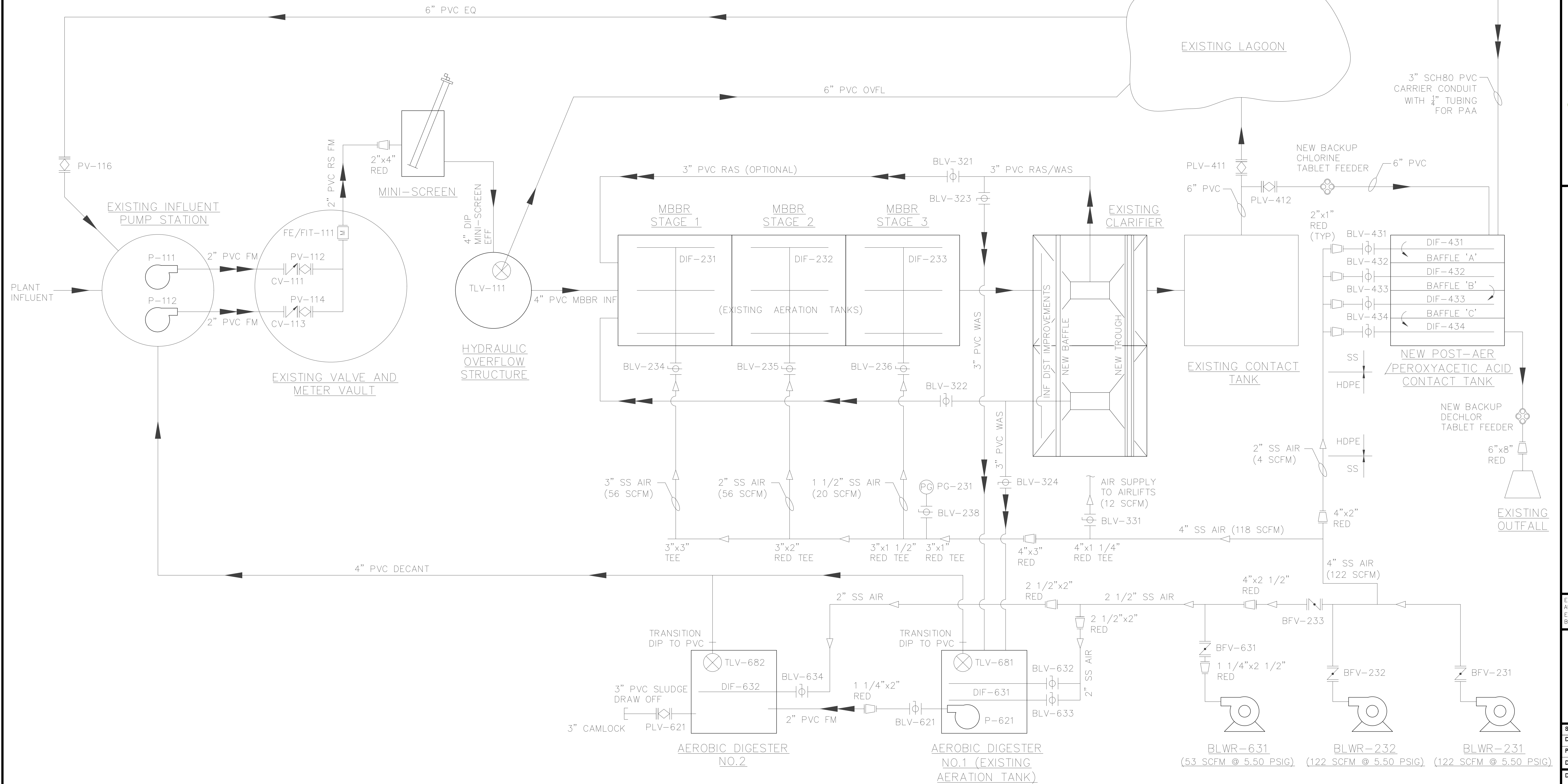

PROCESS FLOW DIAGRAM
 TIMBERLAND WWTF
 6500 US 60 WEST
 PADUCAH, KY

ENGINEERING CERTIFICATE OF AUTHORITY NO. 4808
 ENGINEERING LICENSE: BENJAMIN J. KUENZEL, PE33718

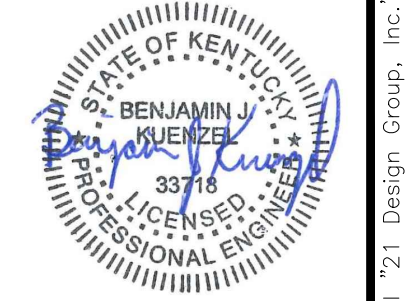

SEAL DATE: 2/15/2021
 DRAWN BY: DDG
 PROJ NUMBER: 0543-19
 DATE: 2/12/2021
 DRAWING NO:

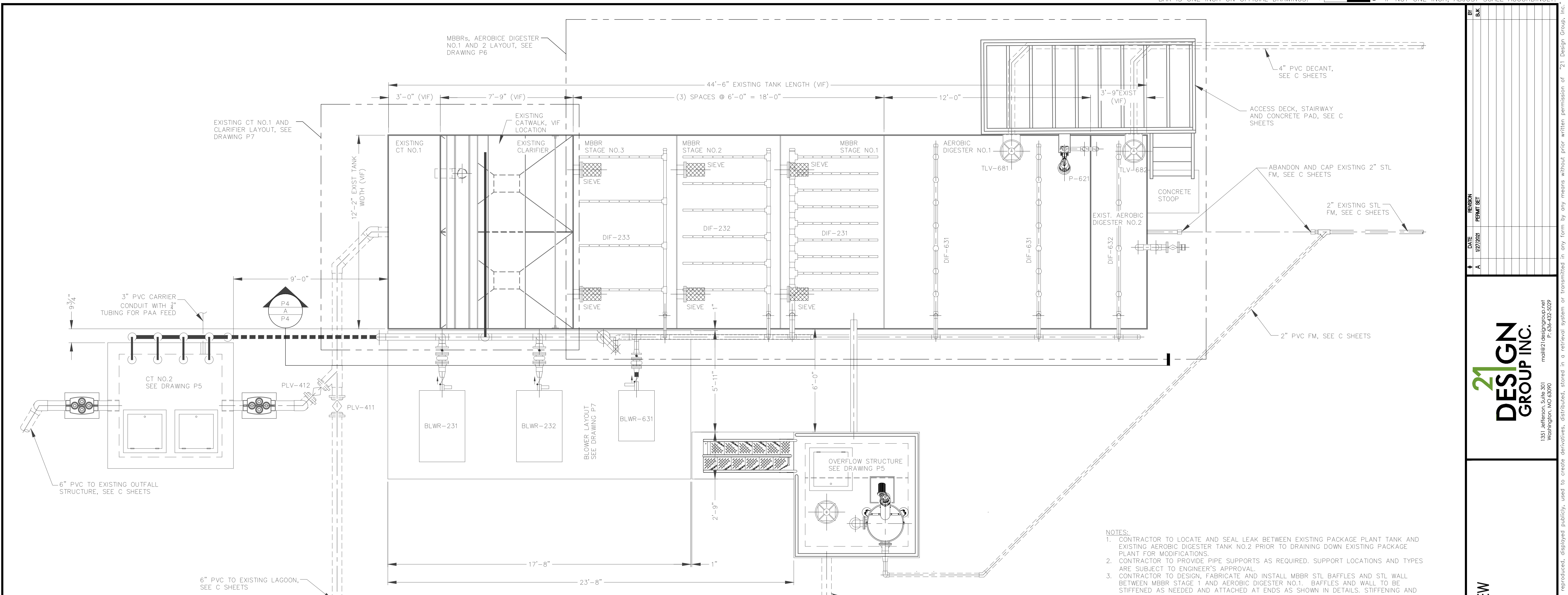

PROCESS PLAN VIEW
SCALE: 3/8" = 1'-0"

- NOTES:**
1. CONTRACTOR TO LOCATE AND SEAL LEAK BETWEEN EXISTING PACKAGE PLANT TANK AND EXISTING AEROBIC DIGESTER TANK NO.2 PRIOR TO DRAINING DOWN EXISTING PACKAGE PLANT FOR MODIFICATIONS.
 2. CONTRACTOR TO PROVIDE PIPE SUPPORTS AS REQUIRED. SUPPORT LOCATIONS AND TYPES ARE SUBJECT TO ENGINEER'S APPROVAL.
 3. CONTRACTOR TO DESIGN, FABRICATE AND INSTALL MBBR STL BAFFLES AND STL WALL BETWEEN MBBR STAGE 1 AND AEROBIC DIGESTER NO.1. BAFFLES AND WALL TO BE STIFFENED AS NEEDED AND ATTACHED AT ENDS AS SHOWN IN DETAILS. STIFFENING AND INSTALLATION METHOD SUBJECT TO ENGINEER'S APPROVAL PRIOR TO FABRICATION.
 4. SEE HYDRAULIC PROFILE SHEET P1 FOR PIPE INV. ELEV.

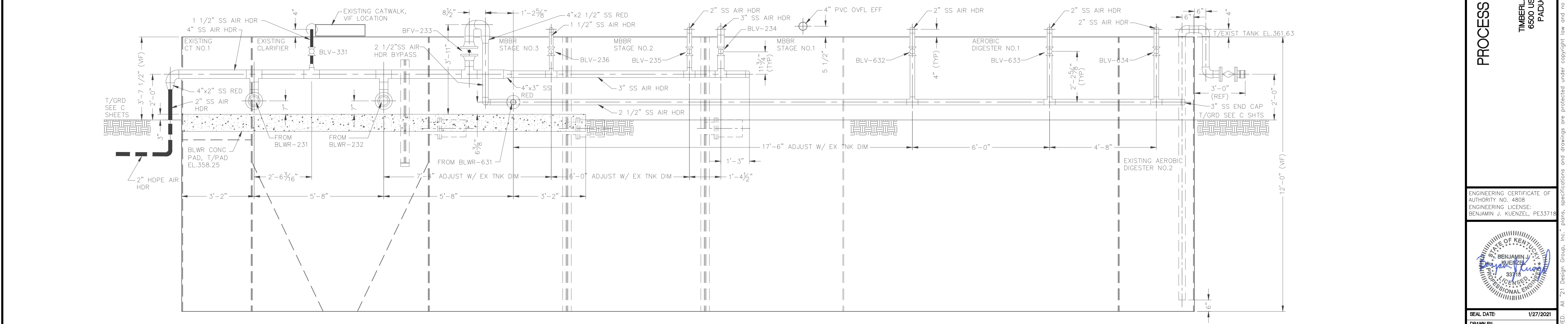

AIR HEADER ELEVATION
SCALE: 1/2" = 1'-0"

REV	DATE	DESCRIPTION
A	12/27/2021	PERMIT SET

DESIGN GROUP INC.
1351 Jefferson, Suite 301
Washington, MO 65756
mail@designgroup.net
735-492-2622

PROCESS PLAN VIEW

TIMBERLAND WWTF
6500 US 60 WEST
PADUCAH, KY

ENGINEERING CERTIFICATE OF AUTHORITY NO. 4808
ENGINEERING LICENSE: BENJAMIN J. KUENZEL, PE33718

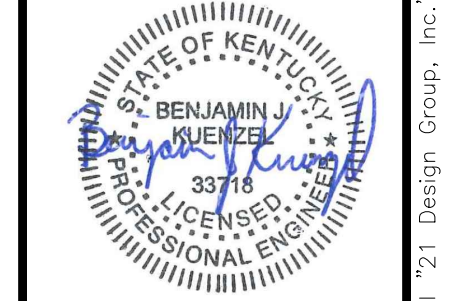

SEAL DATE	1/27/2021
DRAWN BY	DDG
PROJ NUMBER	0543-B
DATE	12/23/2020
DRAWING NO	P4

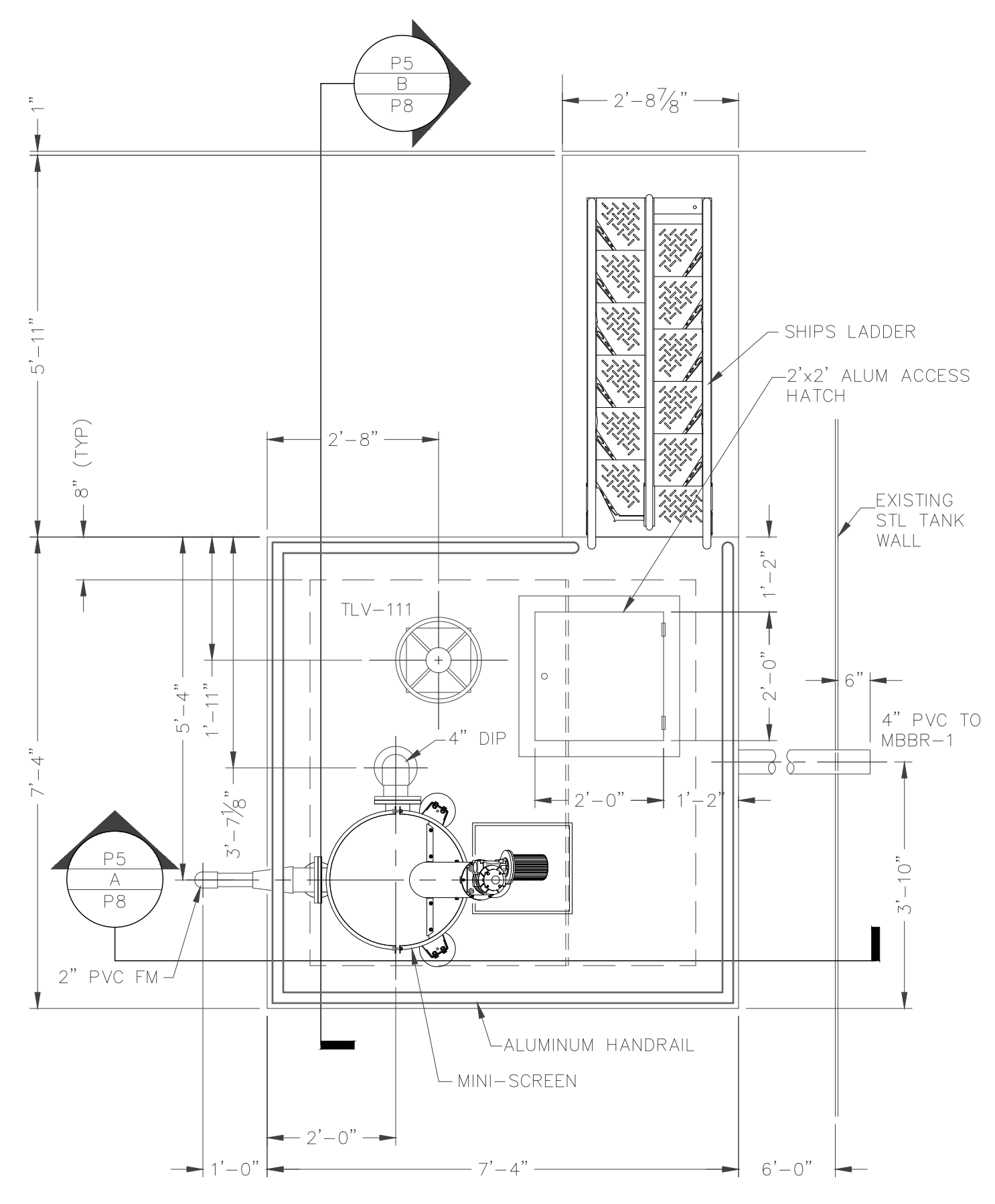

OVERFLOW STRUCTURE UPPER PLAN
SCALE: 1/2" = 1'-0"

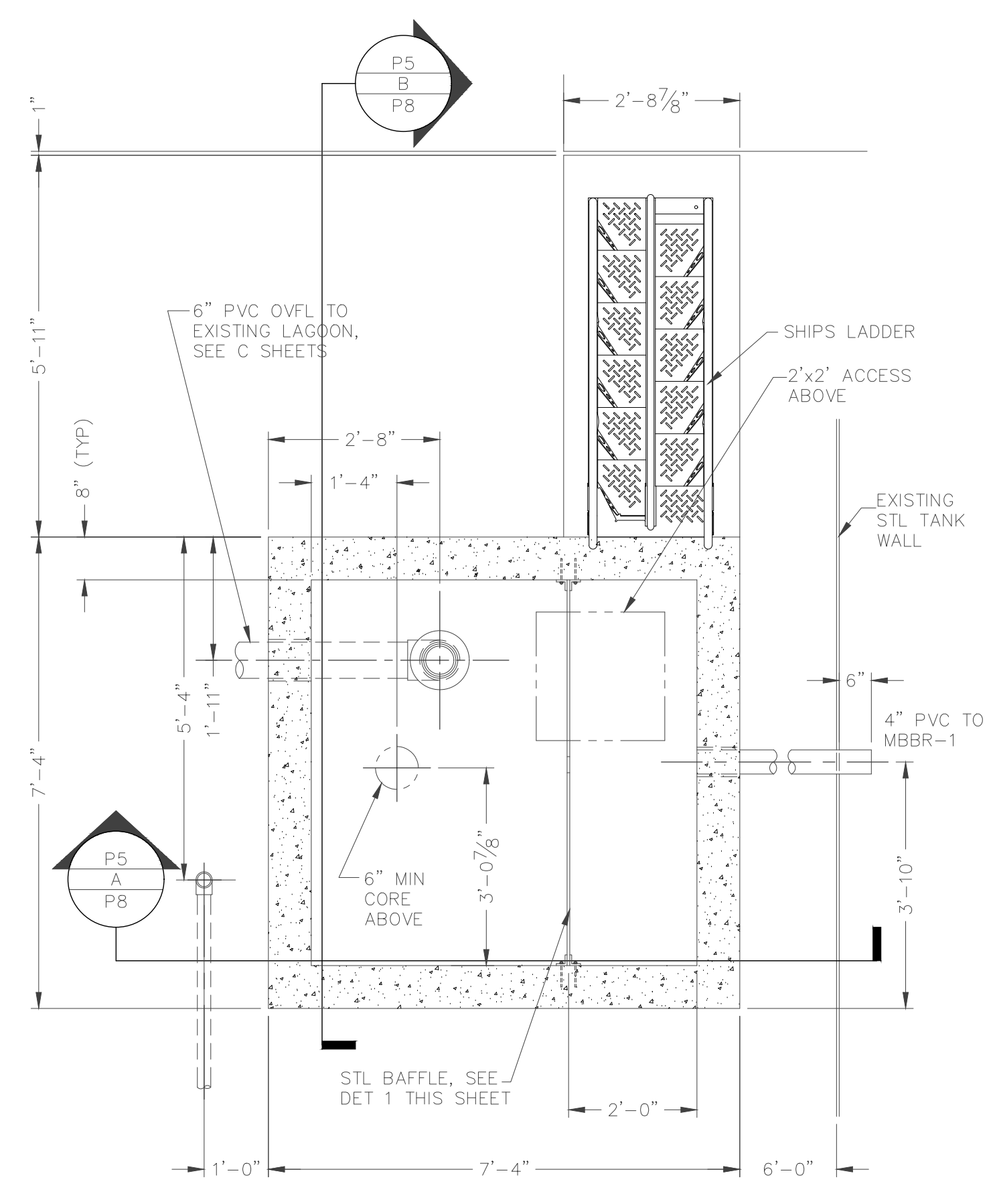

OVERFLOW STRUCTURE LOWER PLAN
SCALE: 1/2" = 1'-0"

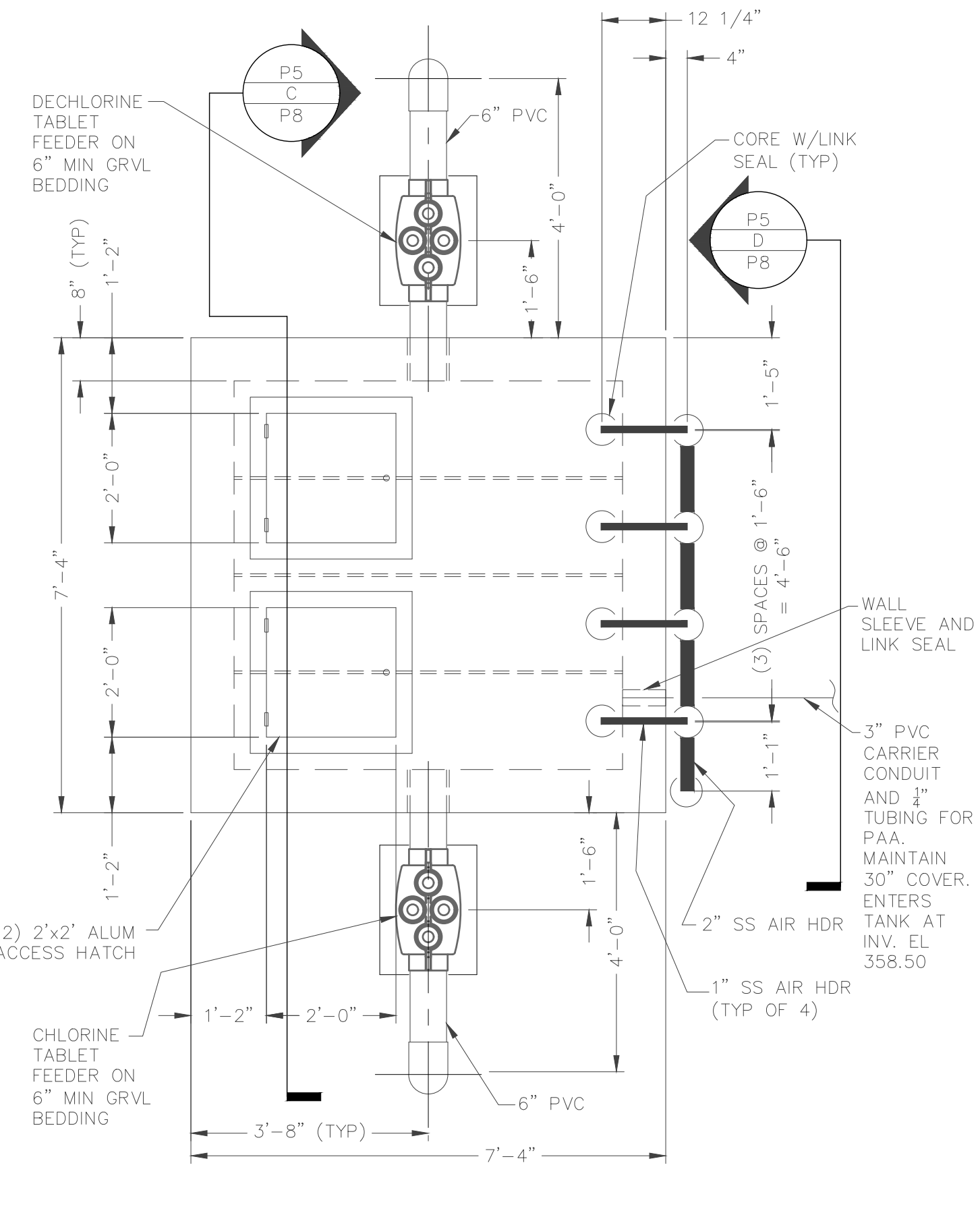

CONTACT TANK NO.2 UPPER PLAN
SCALE: 1/2" = 1'-0"

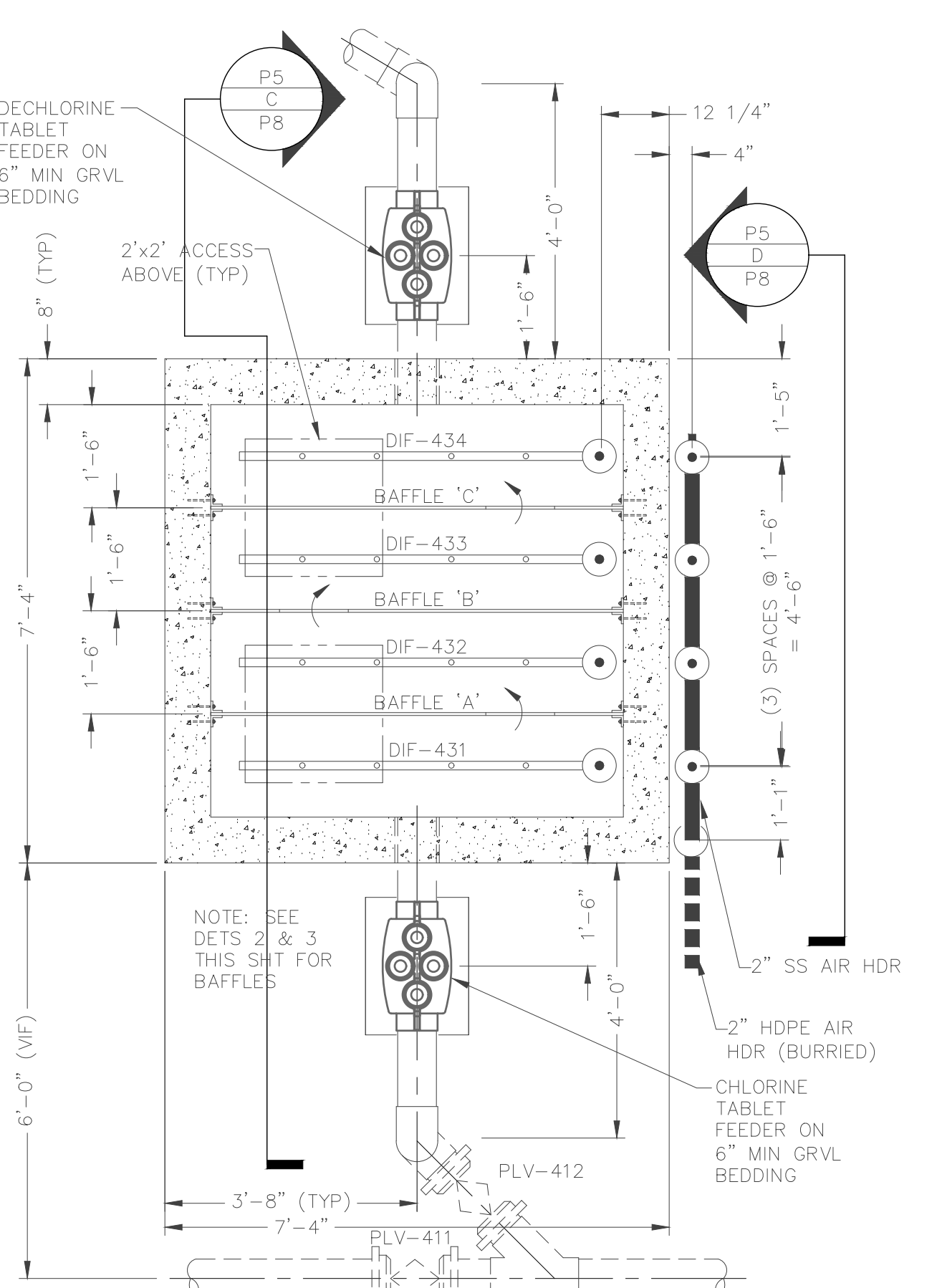

CONTACT TANK NO.2 LOWER PLAN
SCALE: 1/2" = 1'-0"

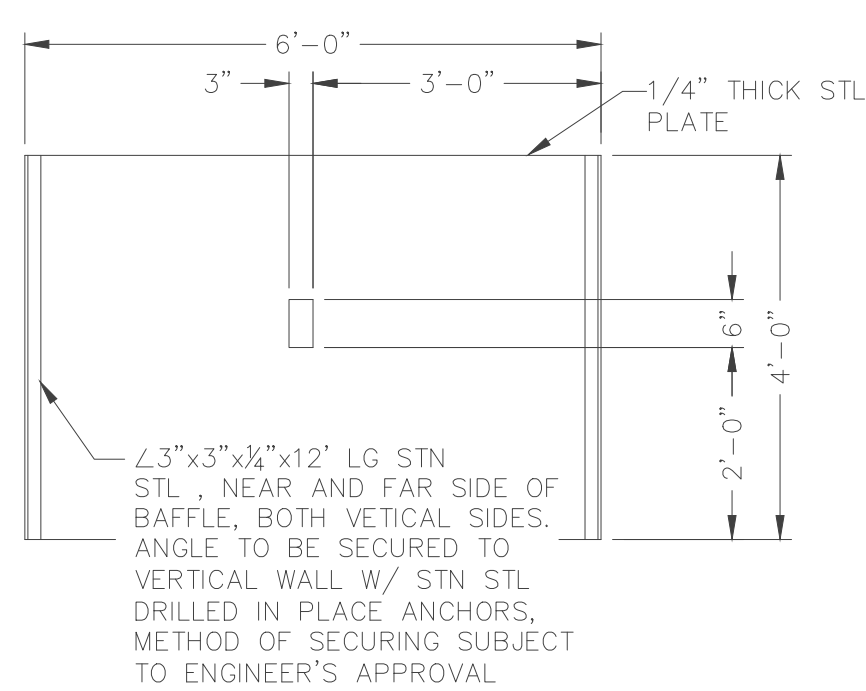

OVFL STRUCTURE BAFFLE
SCALE: 1/2" = 1'-0"

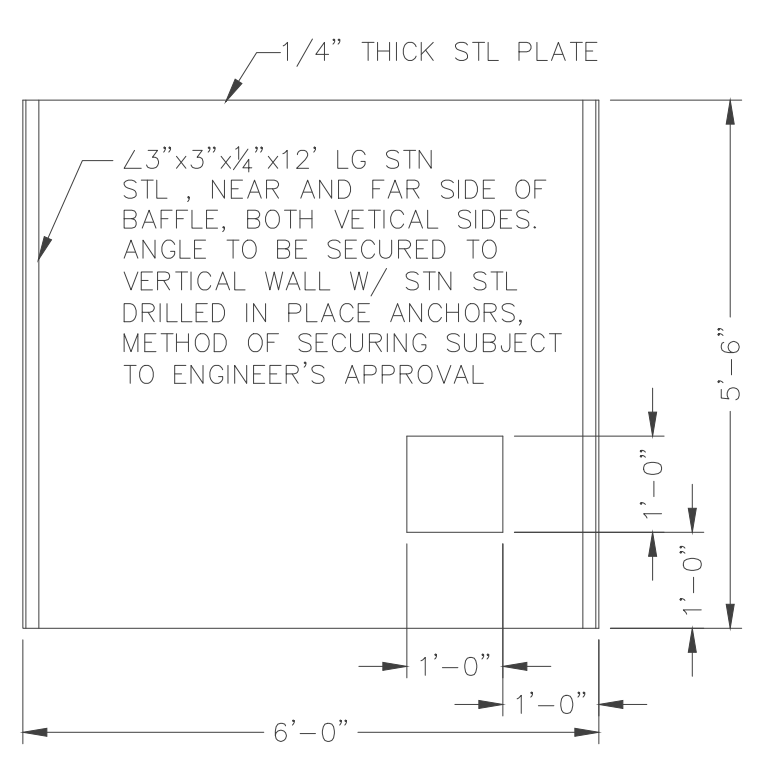

CT NO.2 BAFFLE A & C
SCALE: 1/2" = 1'-0"

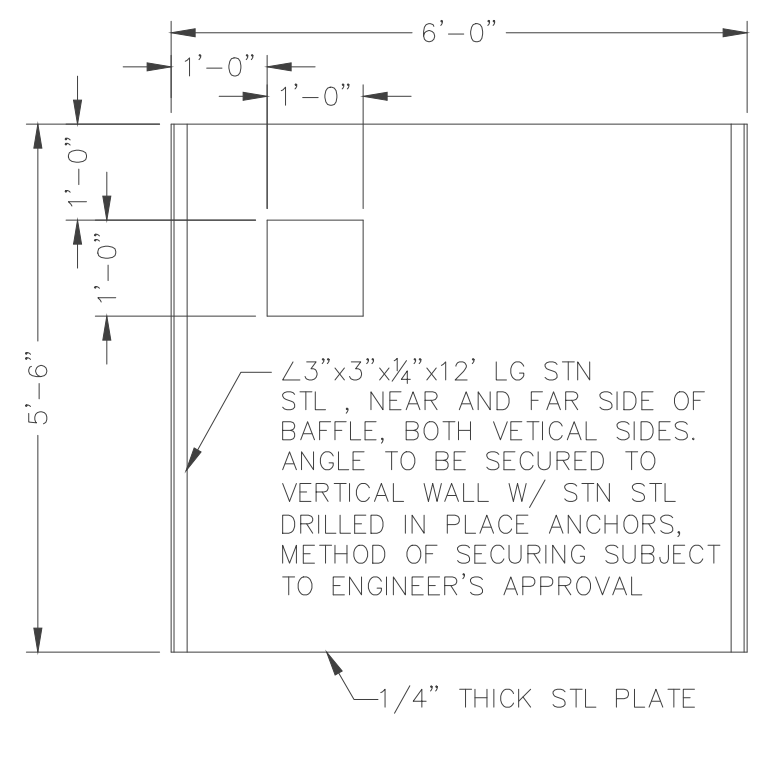

CT NO.2 BAFFLE B
SCALE: 1/2" = 1'-0"

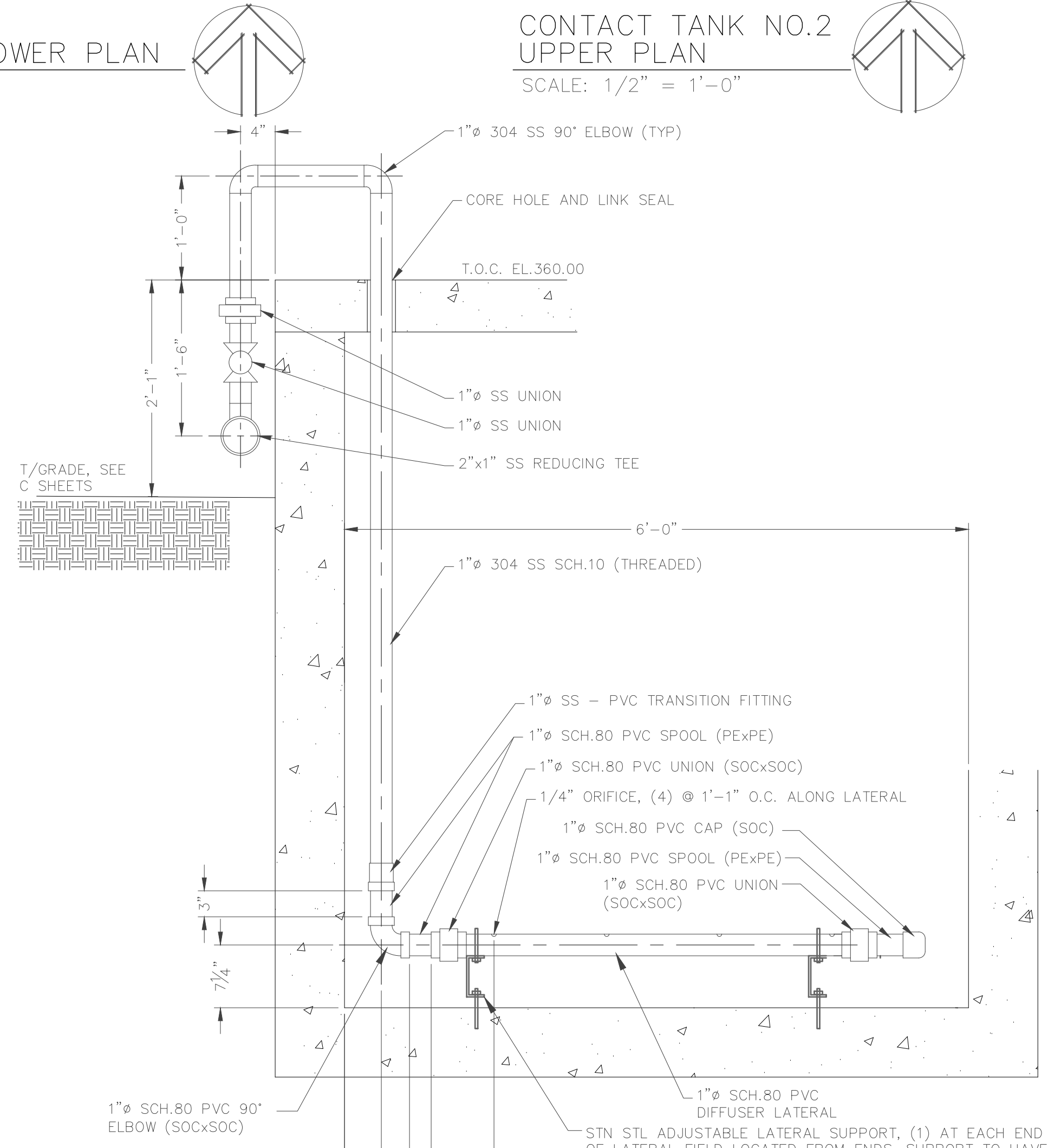

CT NO.2 DIFFUSER DETAIL (DIF-431 THRU 434)
SCALE: 1" = 1'-0"

- DIFFUSER DESCRIPTIONS:**
- DIF-431 1" CPVC AIR LATERAL (4'-4" MIN LENGTH); (4) 1/4" ORIFICES ON 13" CENTERS.
 - DIF-432 1" CPVC AIR LATERAL (4'-4" MIN LENGTH); (4) 1/4" ORIFICES ON 13" CENTERS.
 - DIF-433 1" CPVC AIR LATERAL (4'-4" MIN LENGTH); (4) 1/4" ORIFICES ON 13" CENTERS.
 - DIF-434 1" CPVC AIR LATERAL (4'-4" MIN LENGTH); (4) 1/4" ORIFICES ON 13" CENTERS.

- NOTES:**
- DIMENSIONS ARE BASED ON PRECAST UNITS HAVING 8" WALLS AND 6" TOP SLABS, WHERE APPLICABLE. CONTRACTOR TO ADJUST DIMENSIONS ACCORDINGLY.
 - CONTRACTOR TO PROVIDE PIPE SUPPORTS AS REQUIRED. SUPPORT LOCATIONS AND TYPES ARE SUBJECT TO ENGINEER'S APPROVAL.
 - CONTRACTOR TO DESIGN AND FABRICATE STN STL BAFFLE W/ STN STL ANGLE SUPPORTS. PROVIDE NEOPRENE GASKETS WHERE ANGLE IS IN CONTACT W/ CONCRETE AND SUPPLY STN STL DRILLED IN PLACE ANCHORS W/ 3" MIN EMBEDMENT. BAFFLE ANCHORING SYSTEM SUBJECT TO ENGINEER'S APPROVAL.
 - SEE DRAWING P9 FOR PIPE PENETRATION DETAILS AND REQUIREMENTS.
 - SEE HYDRAULIC PROFILE SHEET P1 FOR PIPE INV. ELEVATIONS.



**CONTACT TANK NO. 2 AND OVERFLOW
STRUCTURE PLANS, SECTIONS AND DETAILS**

TIMBERLAND WWTF
6500 US 60 WEST
PADUCAH, KY

ENGINEERING CERTIFICATE OF AUTHORITY NO. 4808
ENGINEERING LICENSE: BENJAMIN J. KUENZEL, PE33718



SEAL DATE: 1/27/2021
DRAWN BY: DDG
PROJ NUMBER: 0542-19
DATE: 12/23/2020
DRAWING NO: P5

ALL RIGHTS RESERVED. All 21 Design Group, Inc., plans, specifications and drawings are protected under copyright law and no part may be copied, reproduced, displayed publicly, used to create derivatives, distributed, stored in a retrieval system or transmitted in any form by any means without prior written permission of 21 Design Group, Inc.

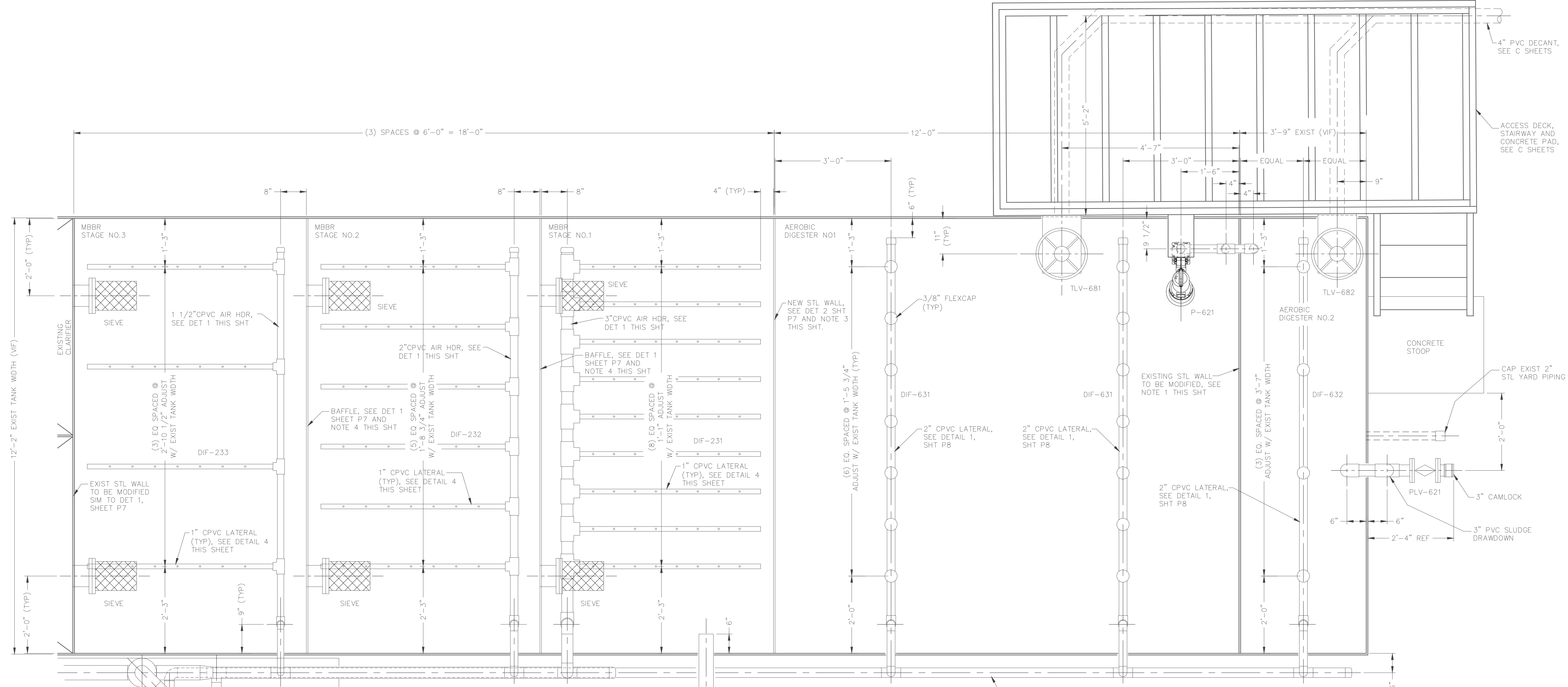

AEROBIC DIGESTER 1 AND 2, MBBR STAGE 1, 2 AND 3 PLAN
SCALE: 3/4" = 1'-0"

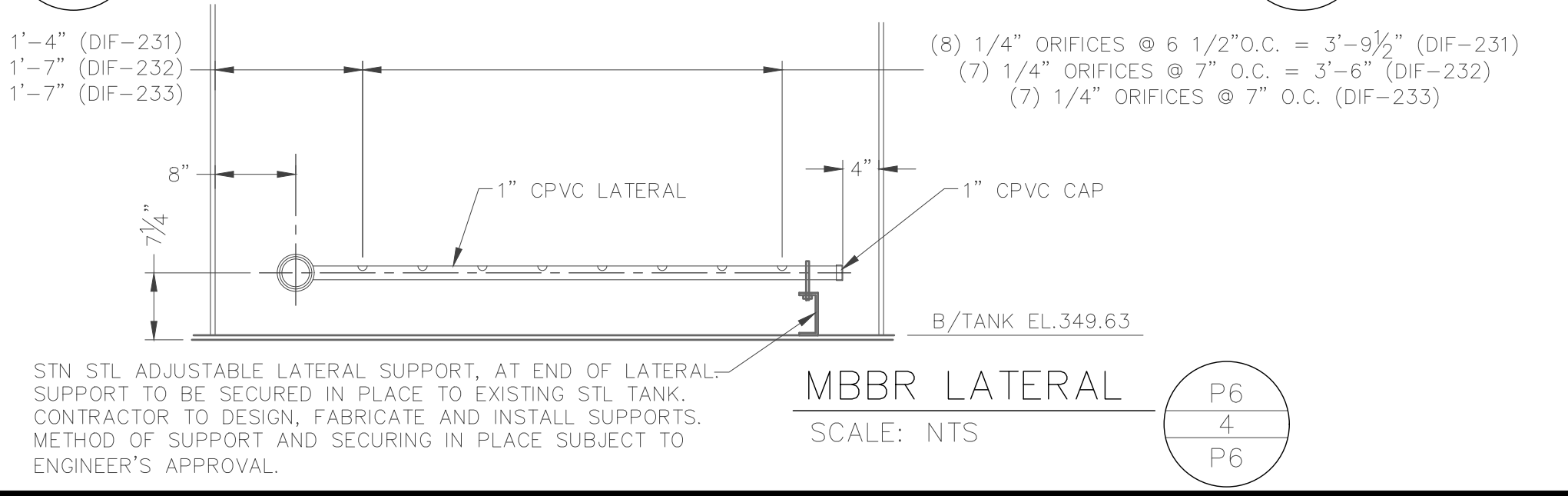
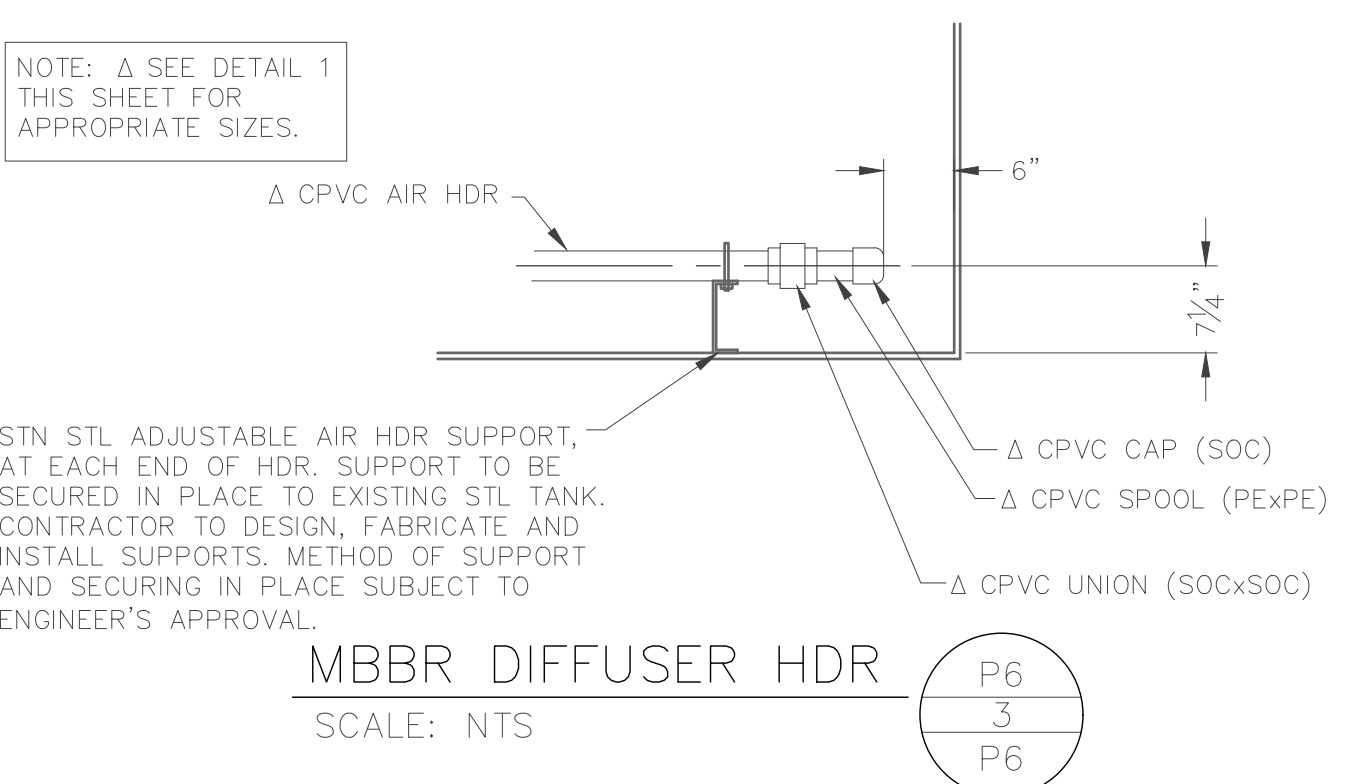
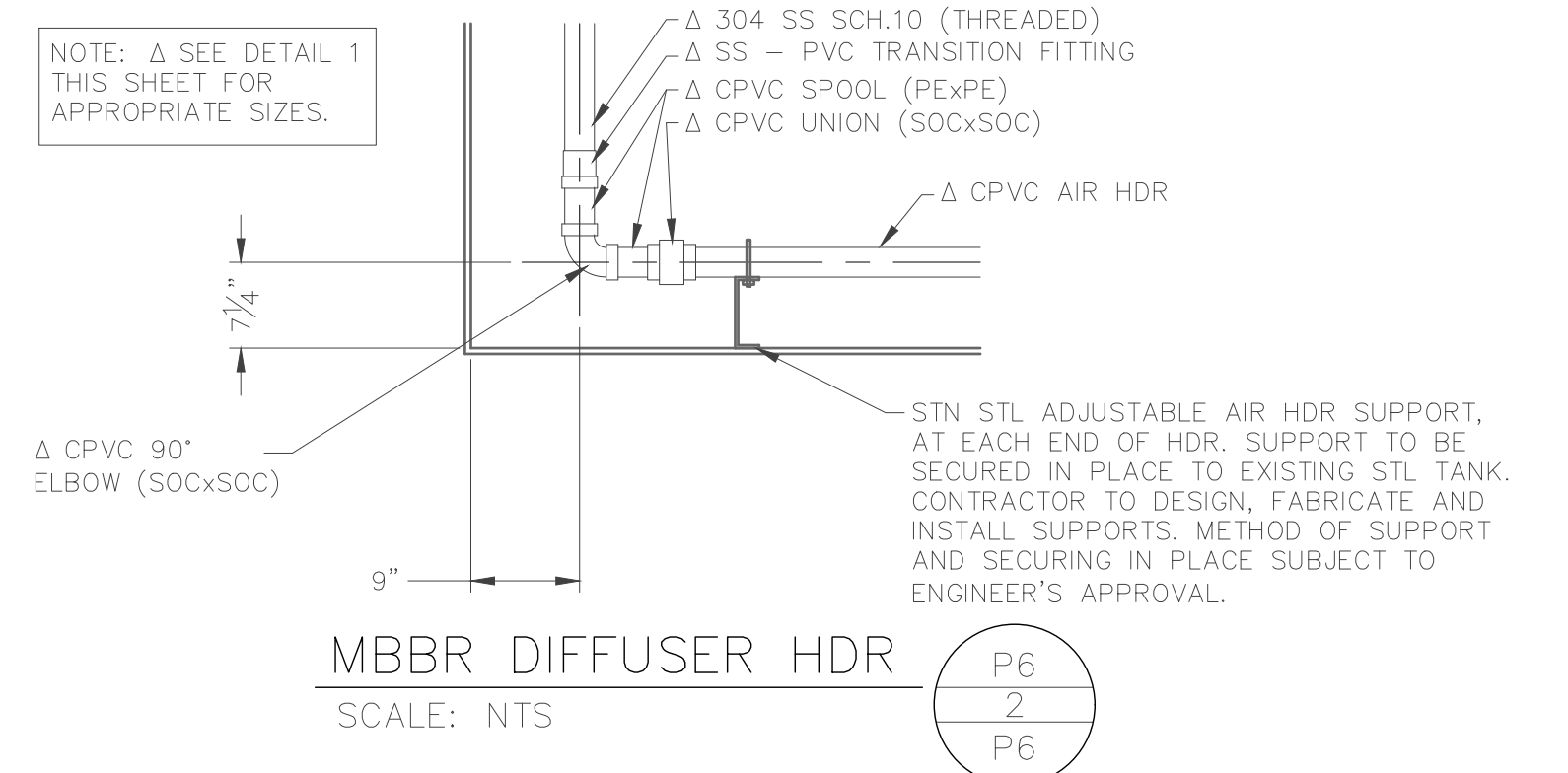
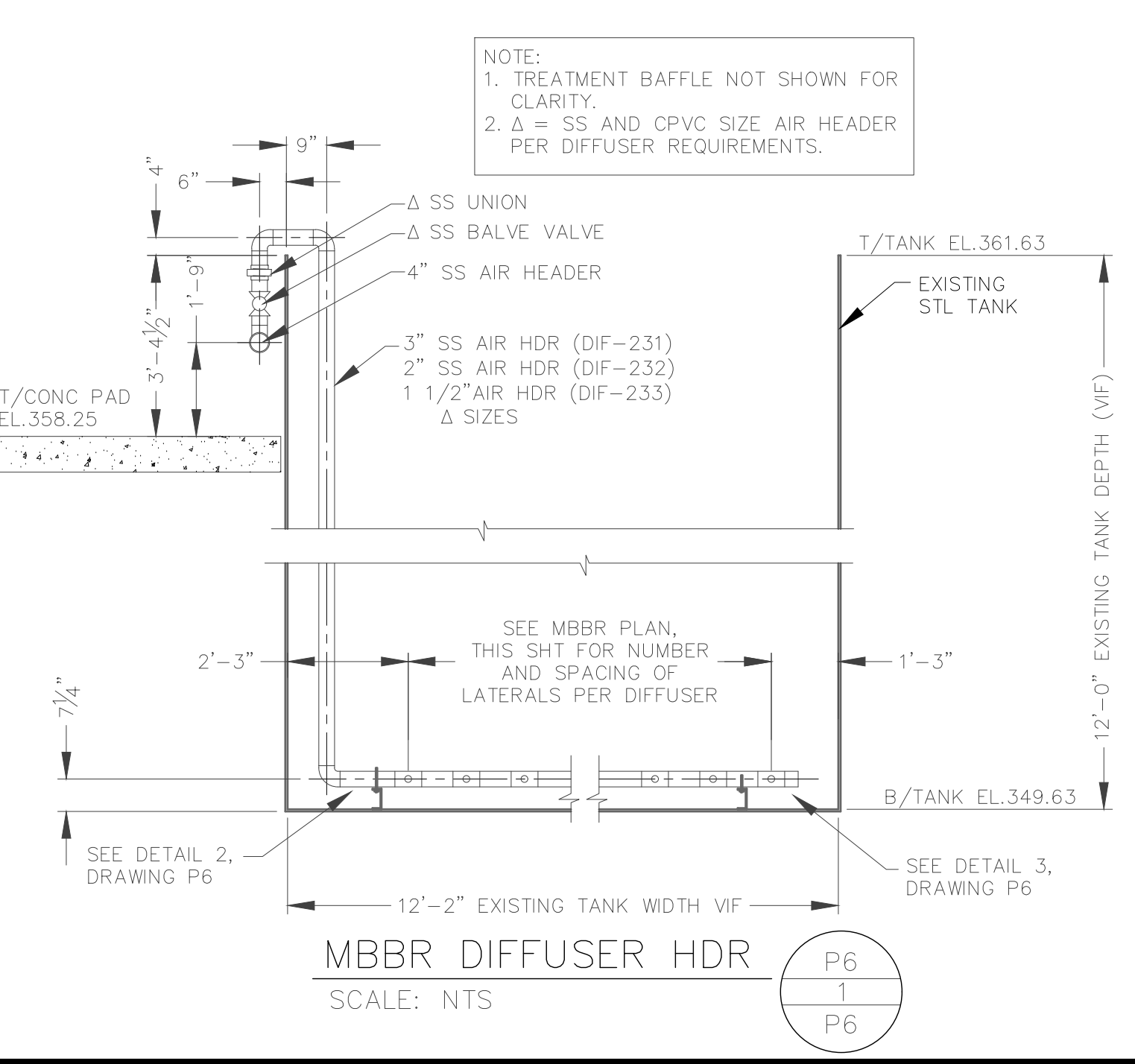

- DIFFUSER DESCRIPTIONS:**
- DIF-231 3" CPVC HEADER, (9) 1" CPVC AIR LATERALS (4'-4" MIN LENGTH); (8) 1/4" ORIFICES ON 6 1/2" CENTERS EACH LATERAL.
 - DIF-232 2" CPVC HEADER, (6) 1" CPVC AIR LATERALS (4'-4" MIN LENGTH); (7) 1/4" ORIFICES ON 7" CENTERS EACH LATERAL.
 - DIF-233 1 1/2" CPVC HEADER, (4) 1" CPVC AIR LATERAL (4'-4" MIN LENGTH); (7) 1/4" ORIFICES ON 7" CENTERS EACH LATERAL.
 - DIF-631 (2) 2" CPVC AIR LATERAL (LENGTH AS SHOWN); (7) 3/8" FLEX CAP ON 1'-4" CENTERS.
 - DIF-632 (1) 2" CPVC AIR LATERAL (LENGTH AS SHOWN); (4) 3/8" FLEX CAP ON 2'-8" CENTERS.

- NOTES:**
- CONTRACTOR TO LOCATE AND SEAL LEAK BETWEEN EXISTING PACKAGE PLANT TANK AND EXISTING AEROBIC DIGESTER TANK NO.2 PRIOR TO DRAINING DOWN EXISTING PACKAGE PLANT FOR MODIFICATIONS.
 - CONTRACTOR TO PROVIDE PIPE SUPPORTS AS REQUIRED. SUPPORT LOCATIONS AND TYPES ARE SUBJECT TO ENGINEER'S APPROVAL.
 - CONTRACTOR TO DESIGN, FABRICATE AND INSTALL NEW STL WALL BETWEEN MBBR STAGE 1 AND AEROBIC DIGESTER NO.1. WALL TO BE STIFFENED AS NEEDED AND ATTACHED AT ENDS AS SHOWN IN DETAIL. STIFFENING AND INSTALLATION METHOD SUBJECT TO ENGINEER'S APPROVAL PRIOR TO FABRICATION.
 - CONTRACTOR TO DESIGN, FABRICATE AND INSTALL MBBR STL BAFFLES. BAFFLES TO BE STIFFENED AS NEEDED AND ATTACHED AT ENDS AS SHOWN IN DETAIL. STIFFENING AND INSTALLATION METHOD SUBJECT TO ENGINEER'S APPROVAL PRIOR TO FABRICATION.
 - SEE HYDRAULIC PROFILE SHEET P1 FOR PIPE INV. ELEV.

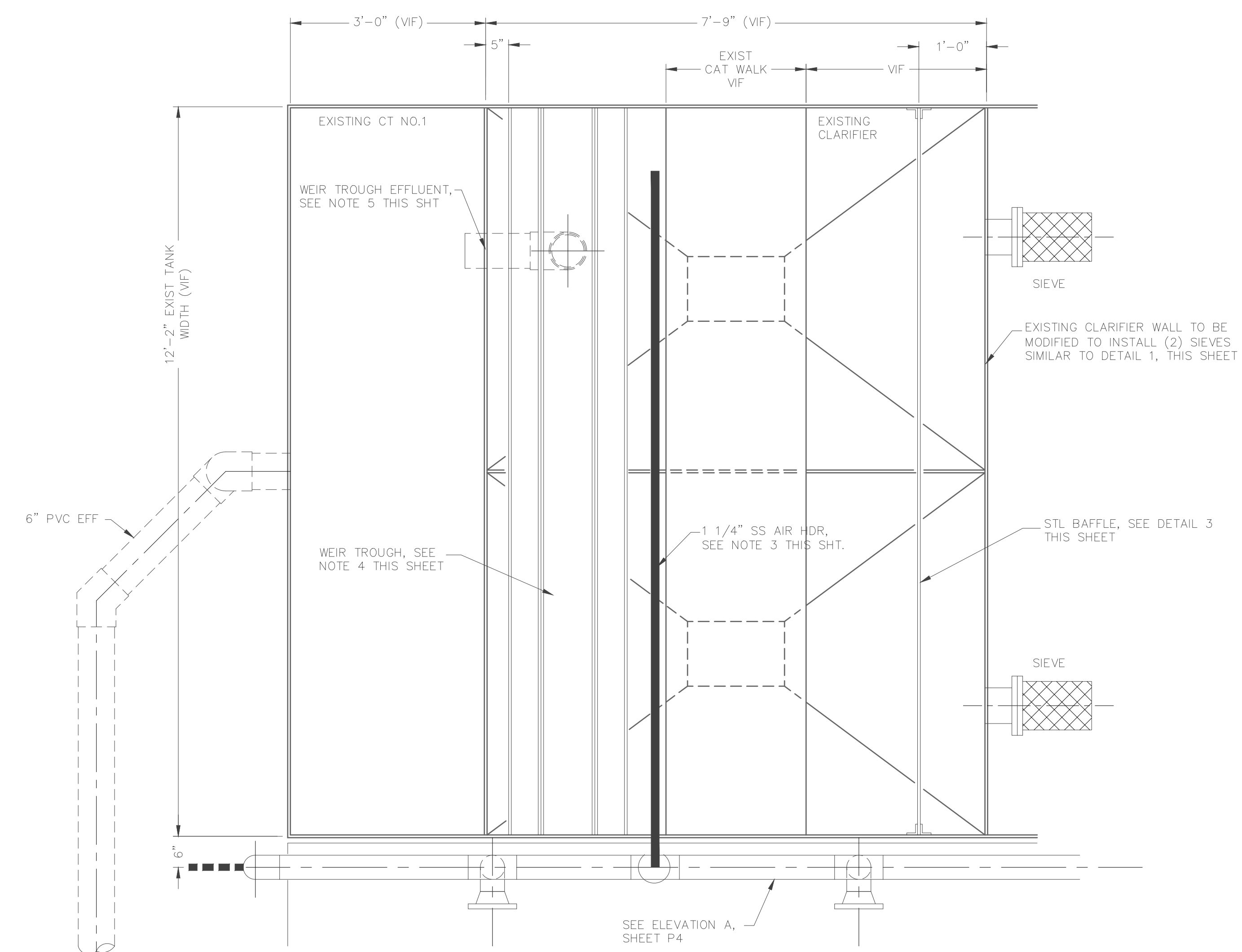

CONTACT TANK NO.1 AND CLARIFIER PLAN
SCALE: 3/4" = 1'-0"

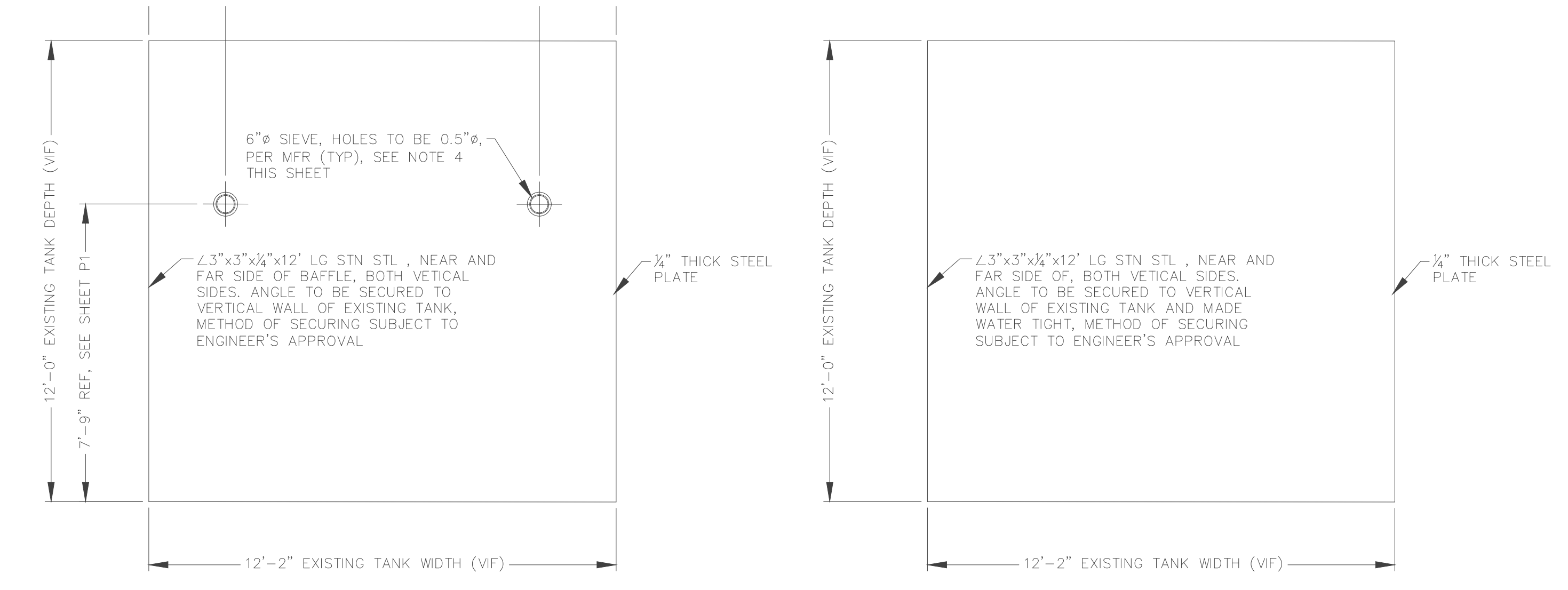

MBBR BAFFLE
SCALE: 3/8" = 1'-0"

AD1 INTERNAL WALL
SCALE: 3/8" = 1'-0"

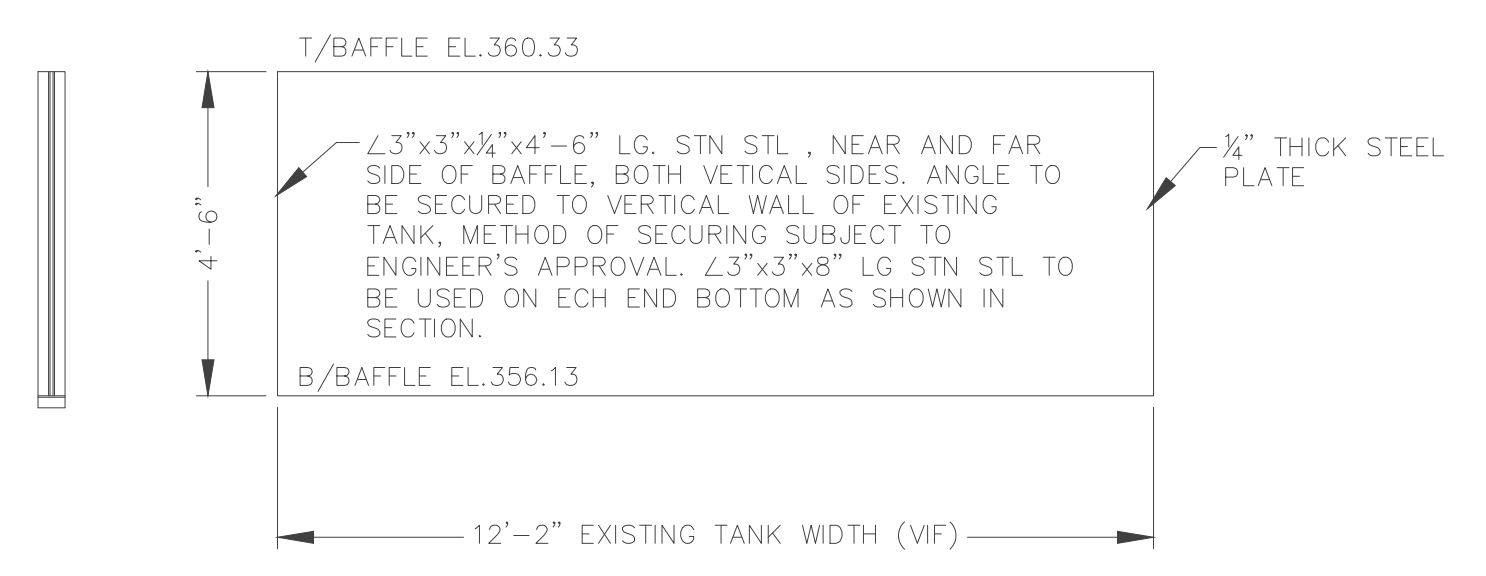

CLARIFIER BAFFLE
SCALE: 3/8" = 1'-0"

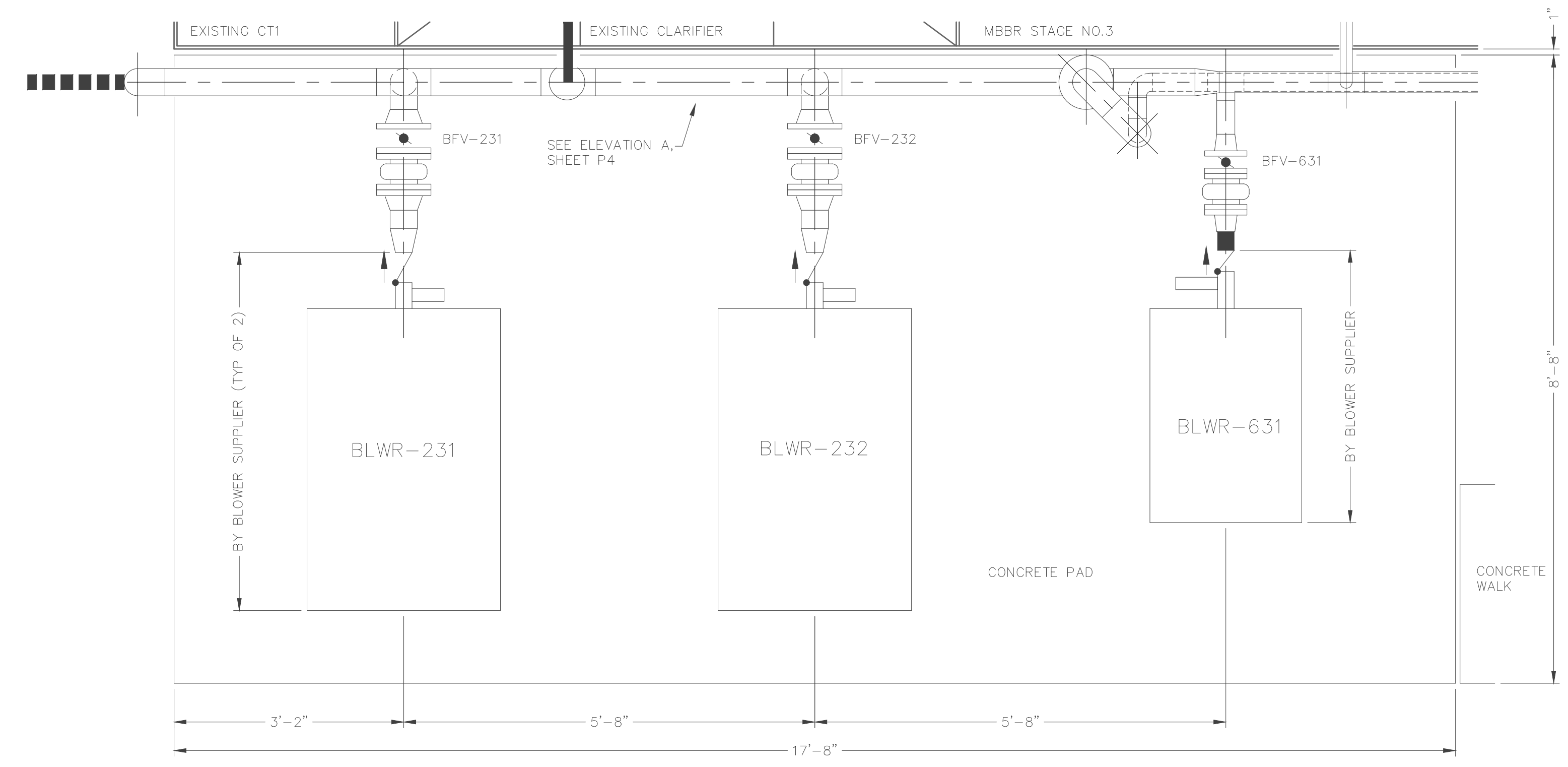

BLOWER PLAN
SCALE: 3/4" = 1'-0"

- NOTES:**
- CONTRACTOR TO PROVIDE PIPE SUPPORTS AS REQUIRED. SUPPORT LOCATIONS AND TYPES ARE SUBJECT TO ENGINEER'S APPROVAL.
 - CONTRACTOR TO DESIGN, FABRICATE AND INSTALL NEW STL BAFFLE IN CLARIFIER. BAFFLE TO BE STIFFENED AS NEEDED AND ATTACHED AT ENDS AS SHOWN IN DETAIL. STIFFENING AND INSTALLATION METHOD SUBJECT TO ENGINEER'S APPROVAL PRIOR TO FABRICATION.
 - CONTRACTOR TO FIELD LOCATE AND SUPPORT AIR SUPPLY STN STL HEADER AND TUBNG SUPPLYING AIR TO EXISTING AIRLIFTS IN CLARIFIER. UTILIZING THE EXISTING CATWALK. METHOD OF CONNECTION TO EXISTING AIRLIFTS IS TO BE IN-KIND WITH EXISTING. ROUTING OF HEADER AND TUBING AS WELL AS SUPPORTS ARE SUBJECT TO ENGINEER'S APPROVAL.
 - SEE HYDRAULIC PROFILE SHEET P1 FOR PIPE INV. ELEV. AND WEIR TROUGH ELEV.
 - LOCATION OF WEIR TROUGH EFFLUENT LINE TO EXISTING CCT NO.1 TO BE FIELD LOCATED BASED ON AN EXISTING OPENING IN CCT NO.1 WALL BETWEEN CLARIFIER AND CCT NO.1. ONCE OPENING'S LOCATION IS DETERMINED, INSTALL TROUGH PIPE THROUGH EXISTING OPENING. ONCE INSTALLED, OPENING TO BE SEALED AROUND PIPE. ROUTING, PIPE LOCATION AND METHOD OF SEALING WALL AROUND PIPE IS SUBJECT TO ENGINEER'S APPROVAL.

DATE	12/2/2021
REVISION	PERMIT SET
BY	BLK

DESIGN GROUP INC.
1351 Jefferson, Suite 301
Washington, MO 63090
mail@designgroup.net
P: 636-492-2627

CONTACT TANK NO.1, CLARIFIER PLAN AND BLOWER PLAN, SECTIONS AND DETAILS

ENGINEERING CERTIFICATE OF AUTHORITY NO. 4808
ENGINEERING LICENSE: BENJAMIN J. KUENZEL, PE33718

SEAL DATE	1/27/2021
DRAWN BY	DDG
PROJ NUMBER	0542-19
DATE	12/23/2020
DRAWING NO	P7

ALL RIGHTS RESERVED. All 21 Design Group, Inc., plans, specifications and drawings are protected under copyright law and no part may be copied, reproduced, displayed publicly, used to create derivatives, distributed, stored in a retrieval system or transmitted in any form by any means without prior written permission of 21 Design Group, Inc.

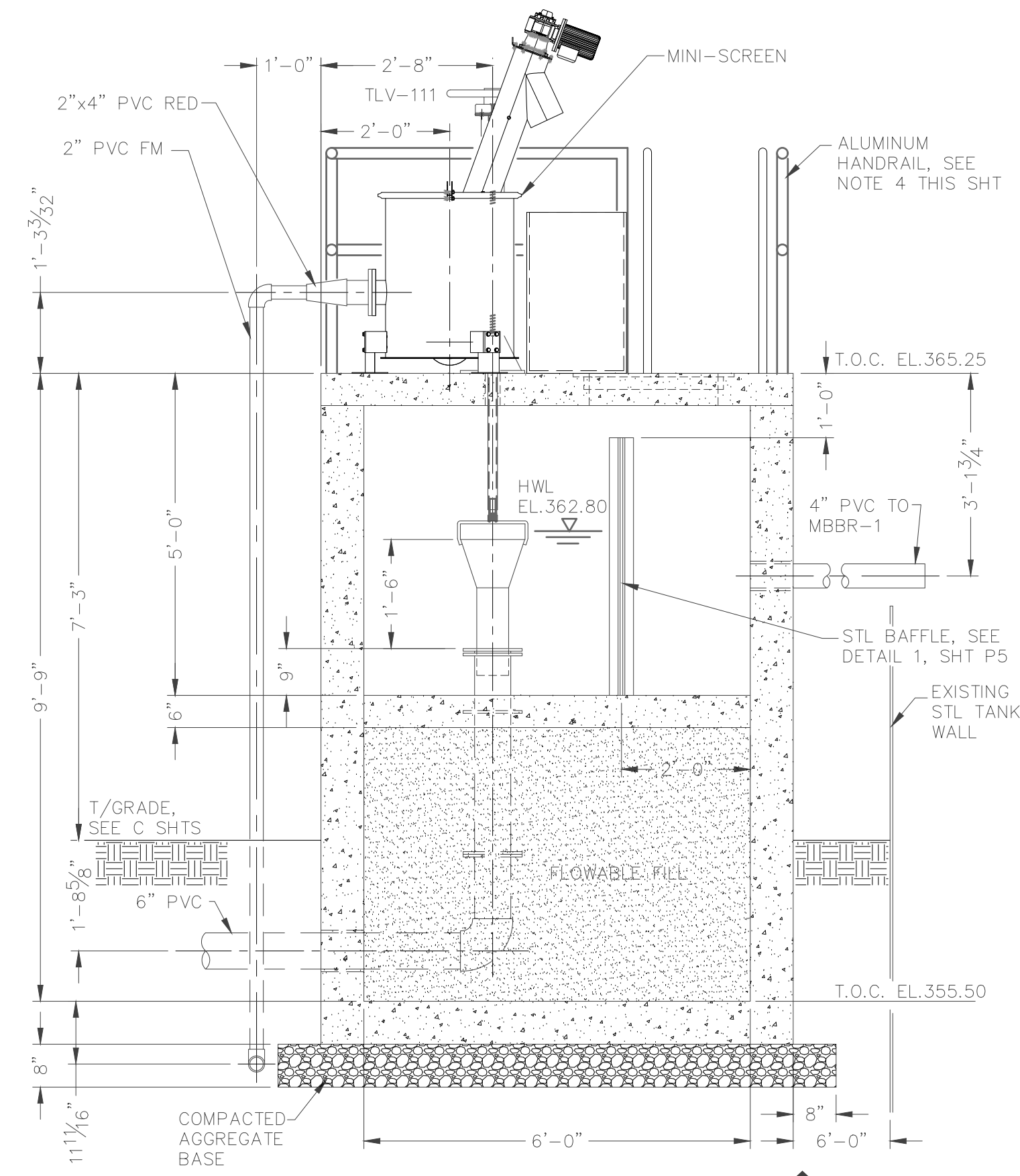

OVERFLOW STRUCTURE SECTION
SCALE: 1/2" = 1'-0"

P5
A
P8

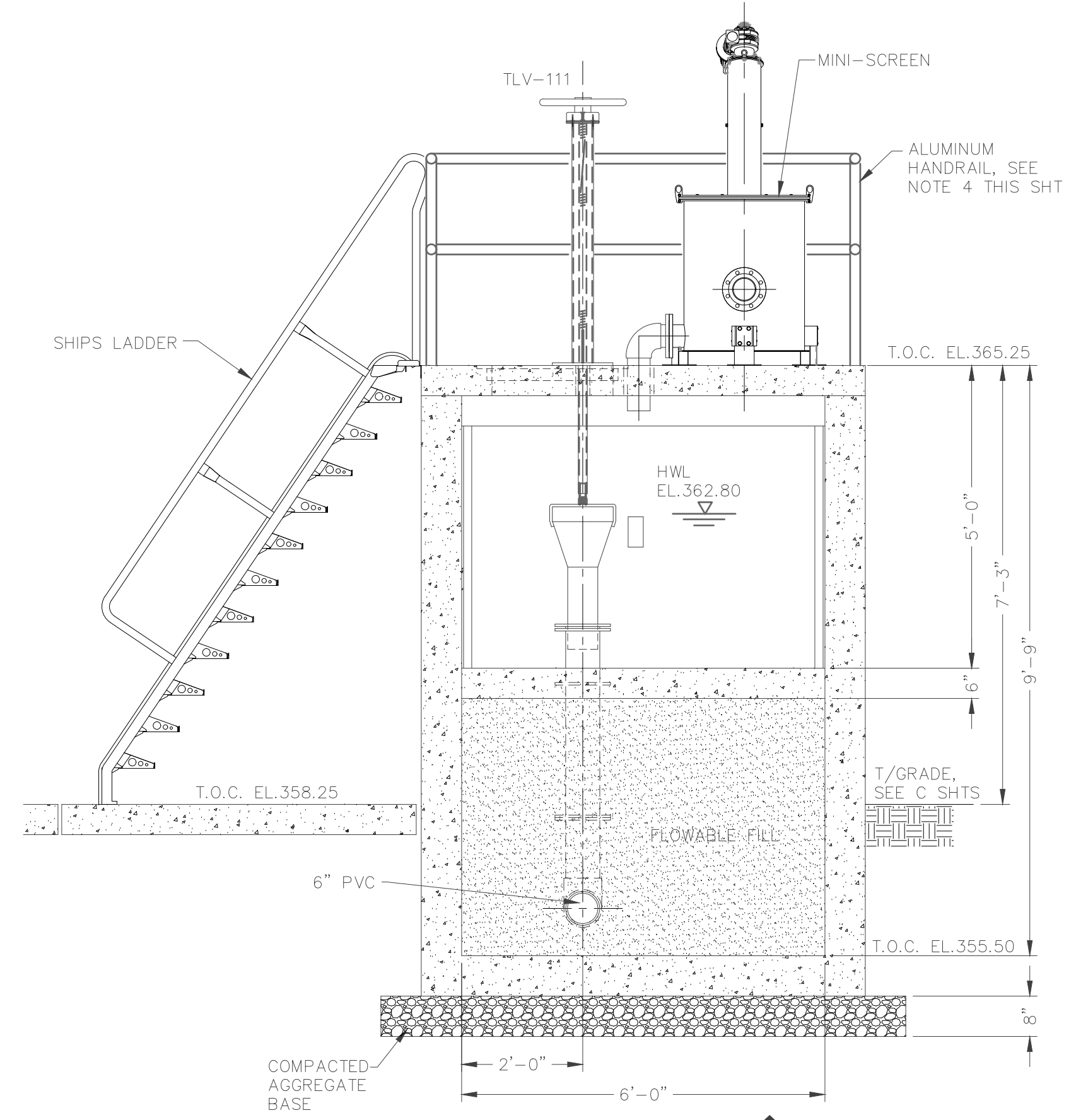

OVERFLOW STRUCTURE SECTION
SCALE: 1/2" = 1'-0"

P5
B
P8

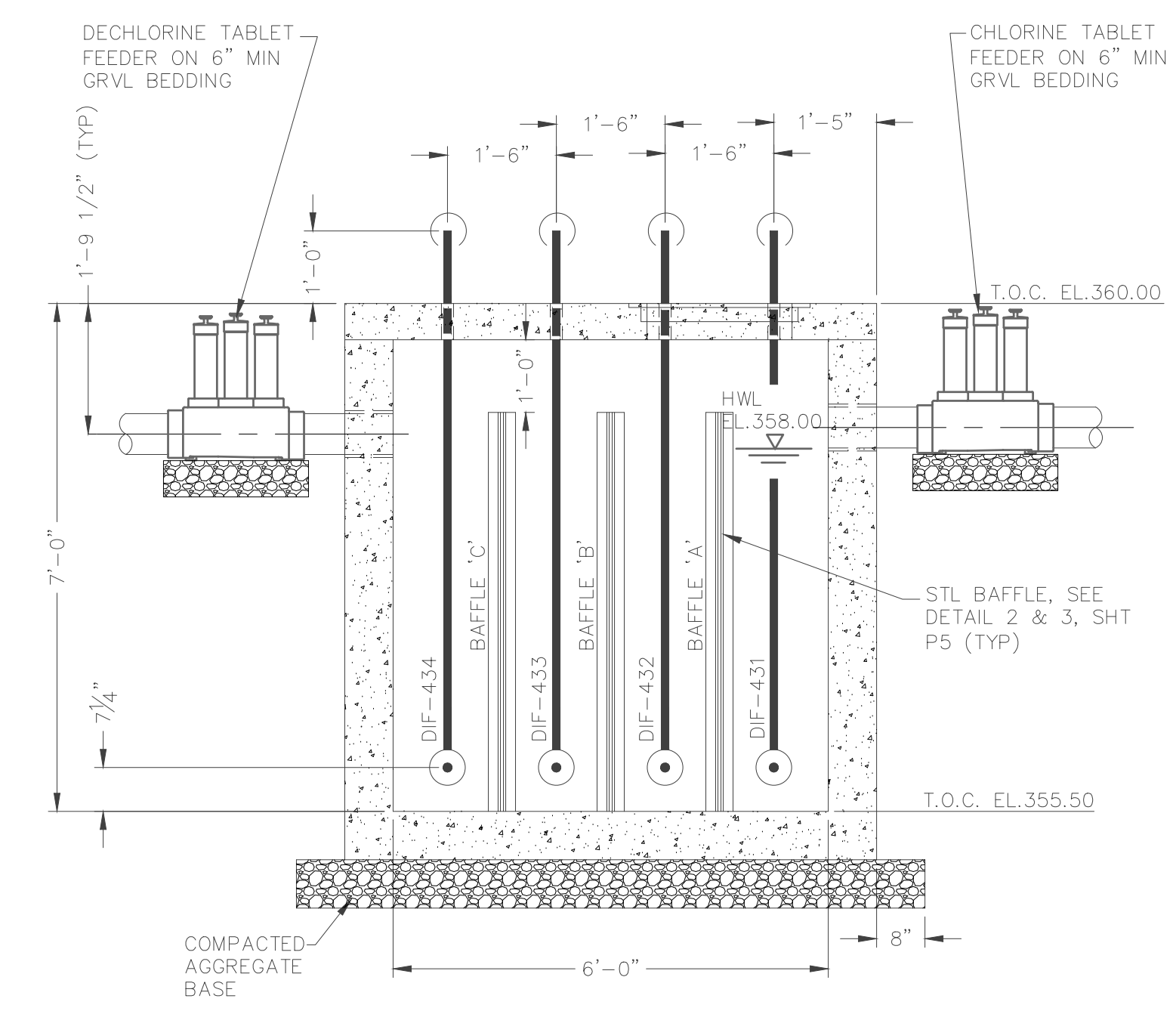

CT NO.2 SECTION
SCALE: 1/2" = 1'-0"

P5
C
P8

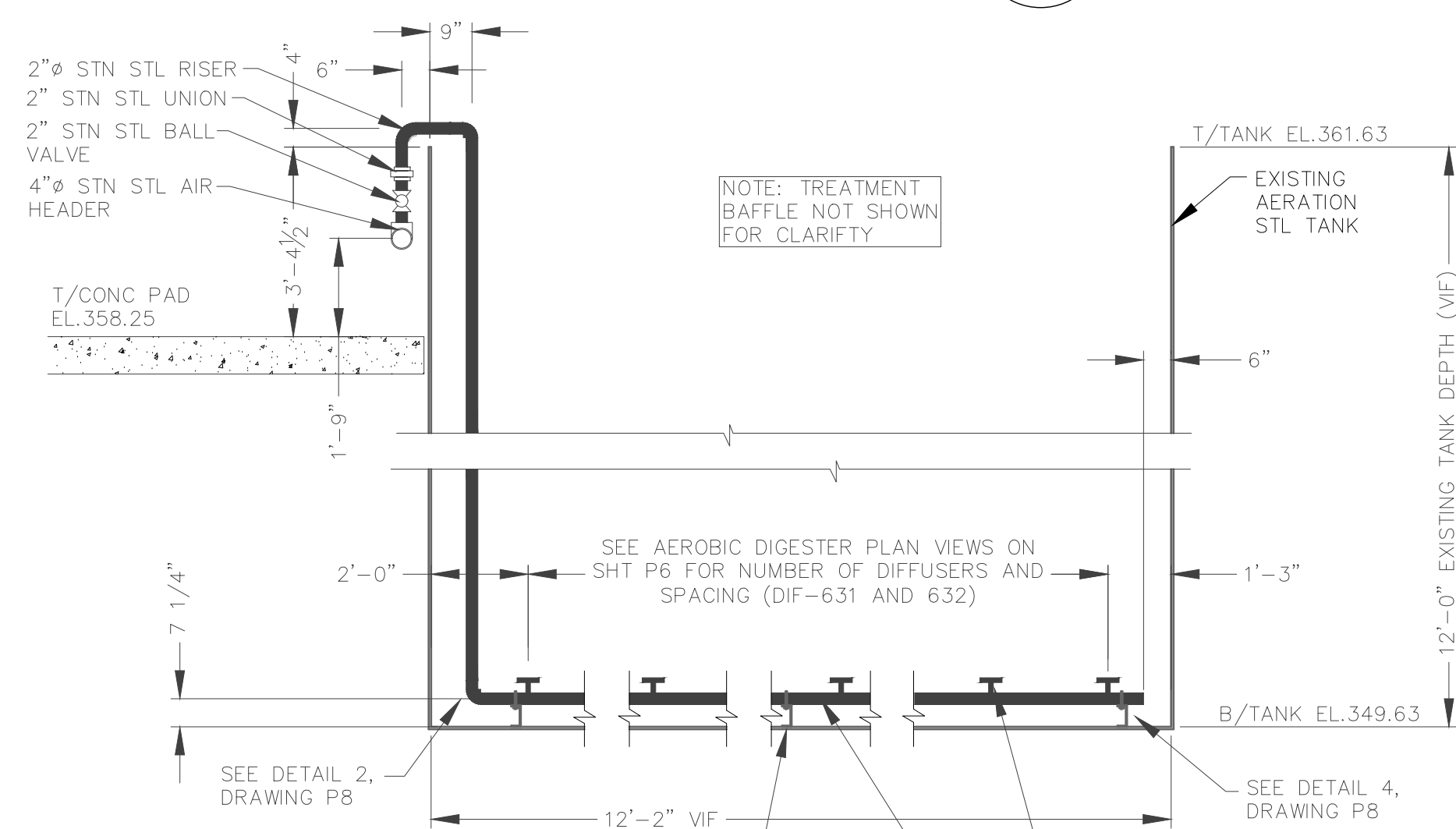

DIGESTER DIFFUSER LATERAL
SCALE: NTS

P6
1
P8

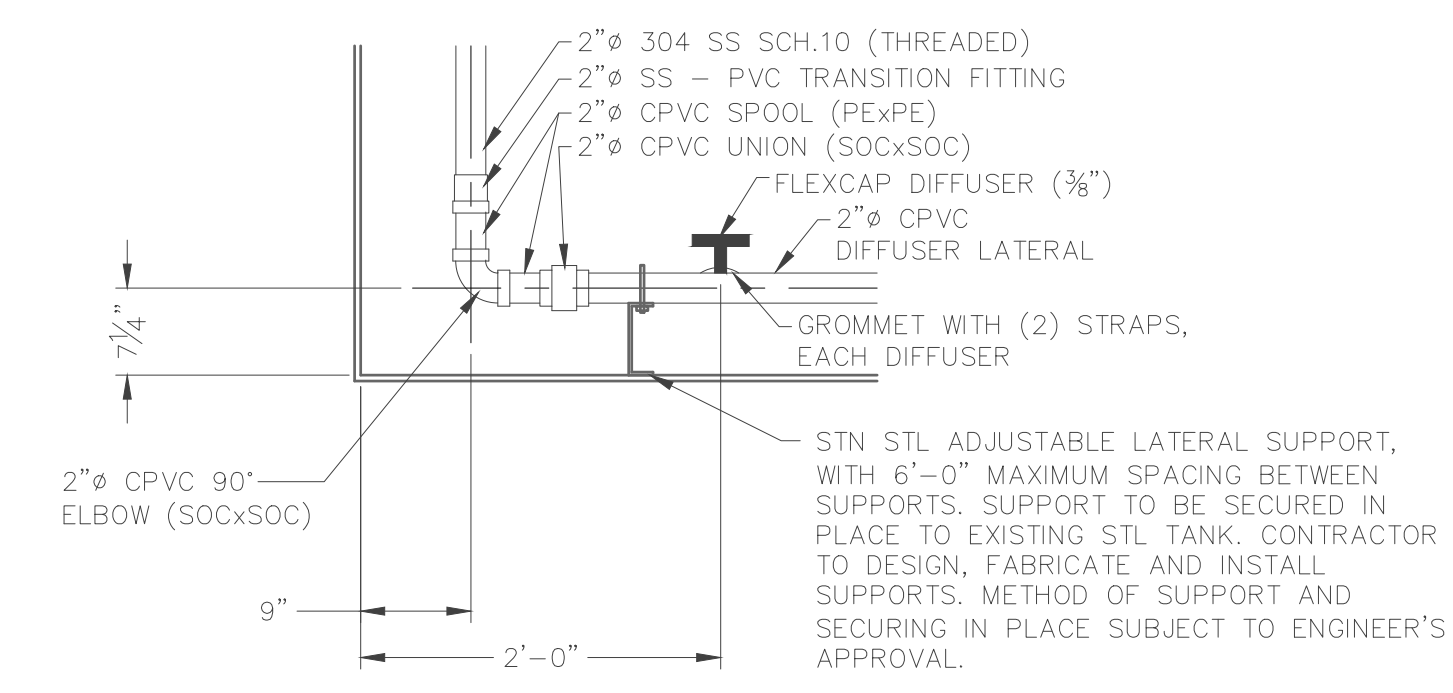

DIGESTER DIFFUSER LATERAL
SCALE: NTS

P6
2
P8

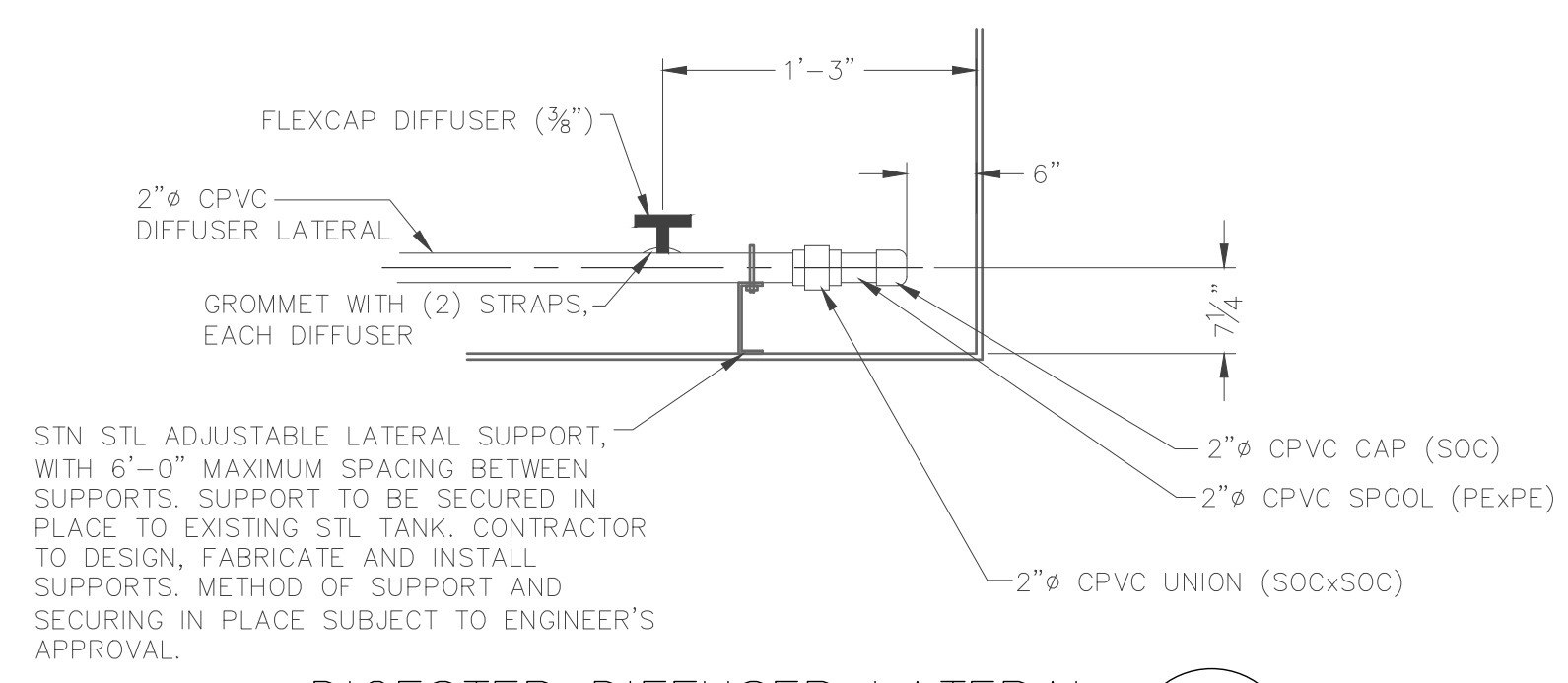

DIGESTER DIFFUSER LATERAL
SCALE: NTS

P6
4
P8

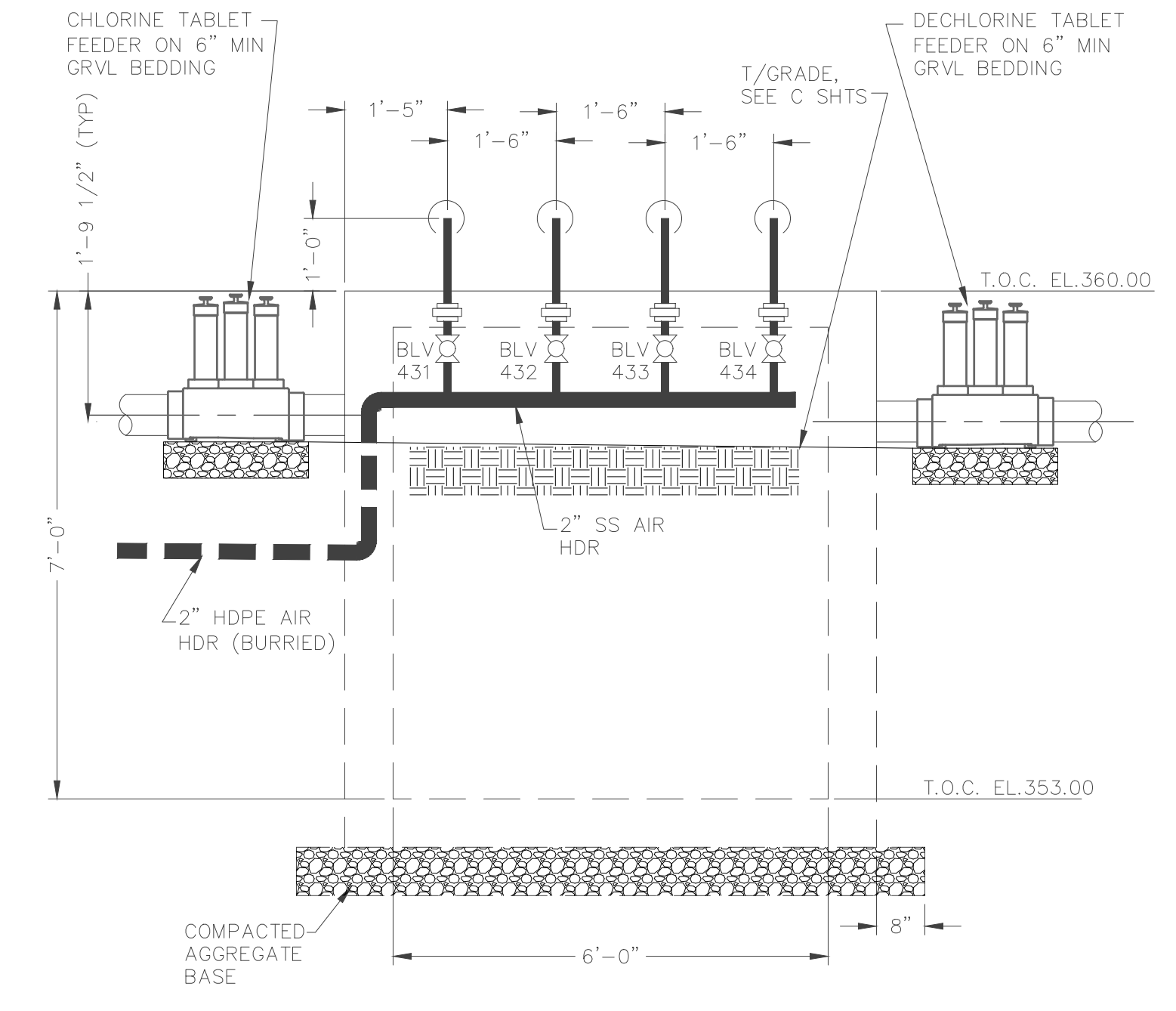

CT NO.2 SECTION
SCALE: 1/2" = 1'-0"

P5
D
P8

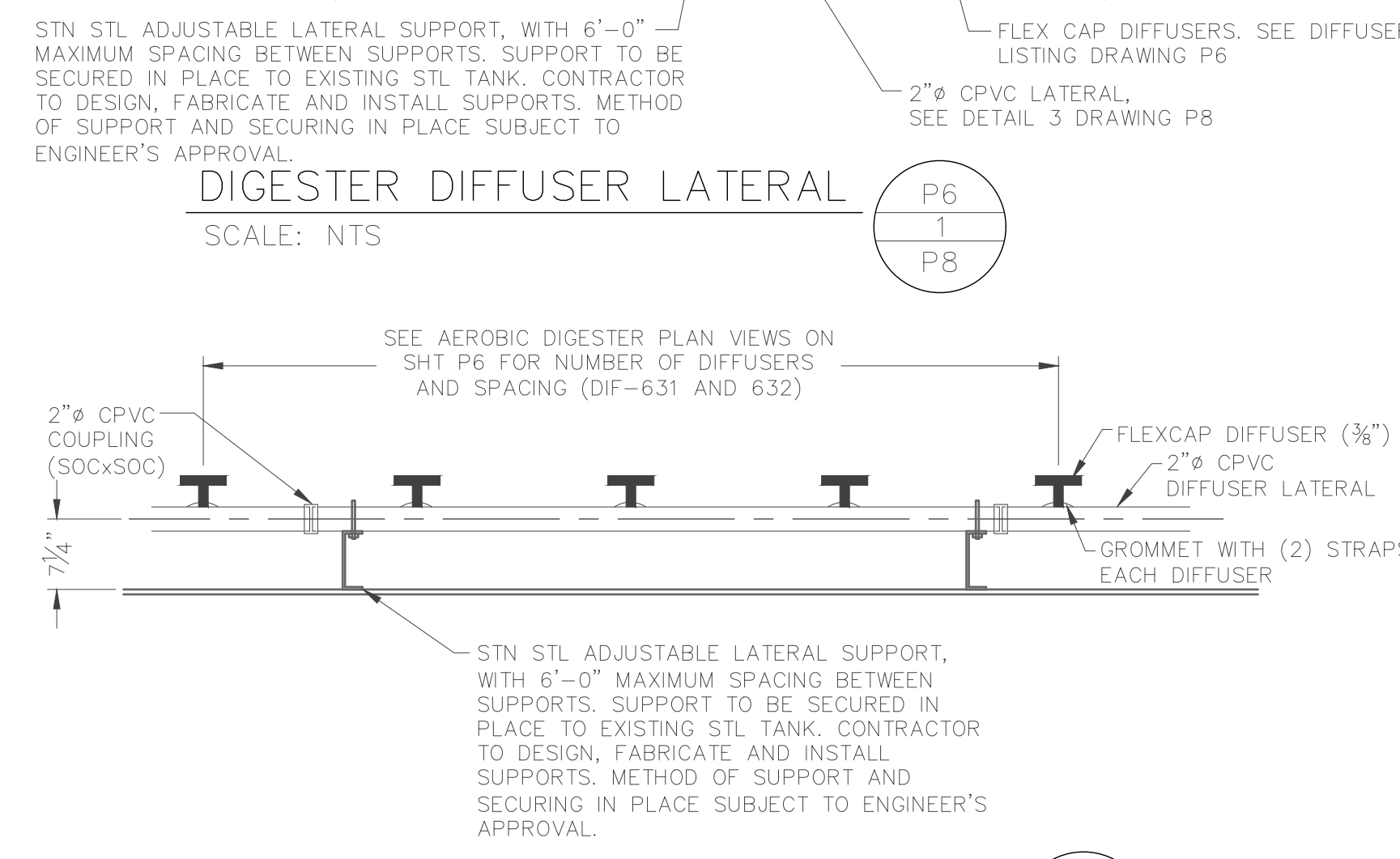

DIGESTER DIFFUSER LATERAL
SCALE: NTS

P6
3
P8

- NOTES:**
- DIMENSIONS ARE BASED ON PRECAST UNITS HAVING 8" WALLS AND 6" TOP SLABS, WHERE APPLICABLE. CONTRACTOR TO ADJUST DIMENSIONS ACCORDINGLY.
 - CONTRACTOR TO PROVIDE PIPE SUPPORTS AS REQUIRED. SUPPORT LOCATIONS AND TYPES ARE SUBJECT TO ENGINEER'S APPROVAL.
 - CONTRACTOR TO DESIGN AND FABRICATE STN STL BAFFLE W/ STN STL ANGLE SUPPORTS. PROVIDE NEOPRENE GASKETS WHERE ANGLE IS IN CONTACT W/ CONCRETE AND SUPPLY STN STL DRILLED IN PLACE ANCHORS W/ 3" MIN EMBEDMENT. BAFFLE ANCHORING SYSTEM SUBJECT TO ENGINEER'S APPROVAL.
 - CONTRACTOR TO PROVIDE AND INSTALL A DOUBLE SAFETY CHAIN AT HANDRAIL ATOP SHIPS LADDER ACCESS POINT COMPLETE WITH HARDWARE AND DISCONNECT CLAMPS..
 - SEE DRAWING P9 FOR PIPE PENETRATION DETAILS AND REQUIREMENTS.
 - SEE HYDRAULIC PROFILE SHEET P1 FOR PIPE INV. ELEV.

DESIGN GROUP INC.
mail@designgroup.net
1351 Jefferson, Suite 301
Washington, MO 63090
P: 636-492-2622

PROCESS SECTIONS
TIMBERLAND WWTF
6500 US 60 WEST
PADUCAH, KY

ENGINEERING CERTIFICATE OF AUTHORITY NO. 4808
ENGINEERING LICENSE: BENJAMIN J. KUENZEL, PE33718



SEAL DATE: 1/27/2021
DRAWN BY: DDG
PROJ NUMBER: 0542-19
DATE: 12/23/2020
DRAWING NO: P8

ALL RIGHTS RESERVED. All 21 Design Group, Inc., plans, specifications and drawings are protected under copyright law and no part may be copied, reproduced, displayed publicly, used to create derivatives, distributed, stored in a retrieval system or transmitted in any form by any means without prior written permission of 21 Design Group, Inc.

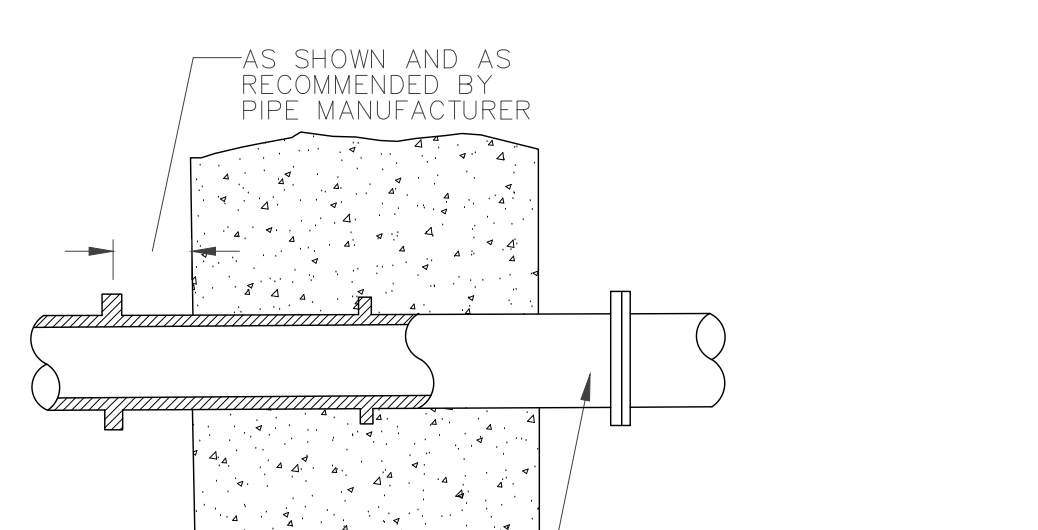
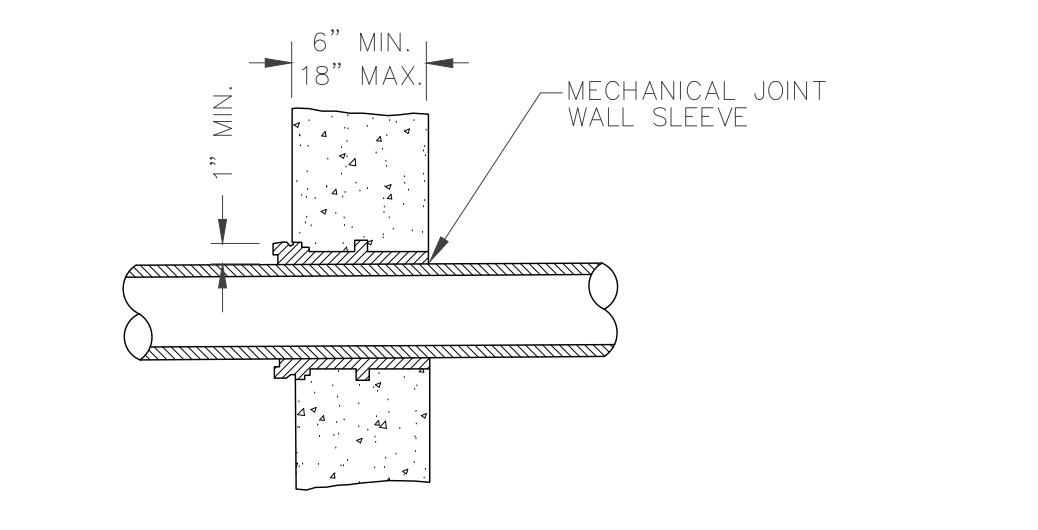
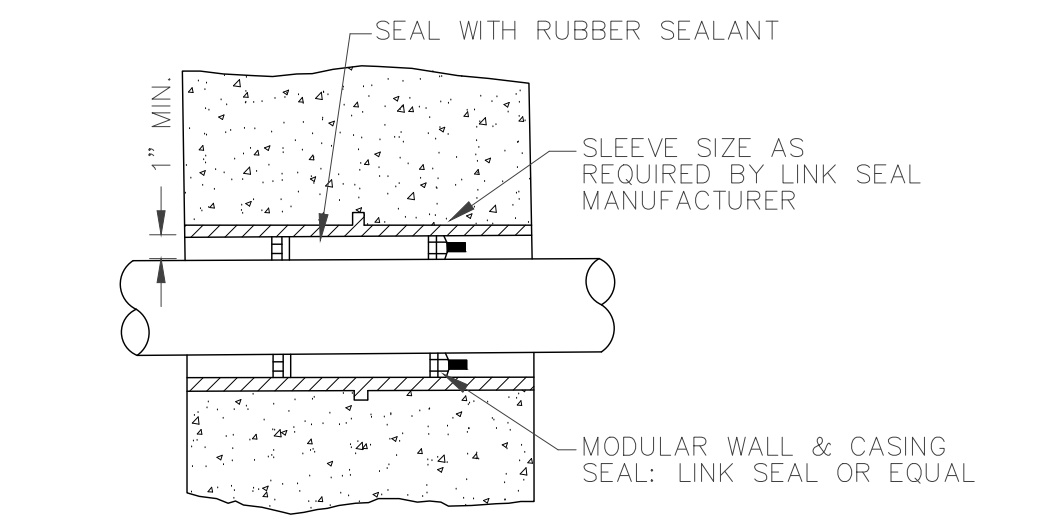
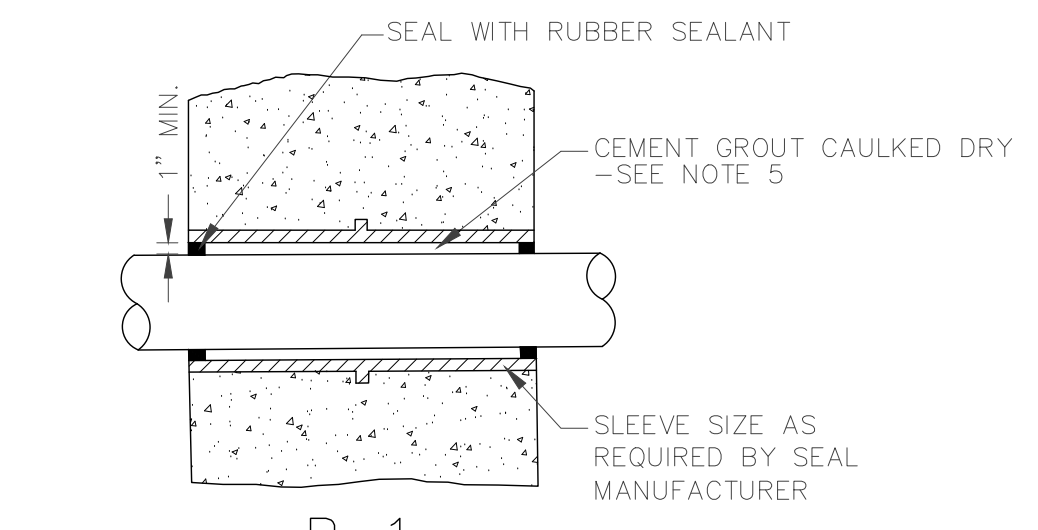

PIPE MATERIAL

CONDITION	STEEL	COPPER	PVC	IRON
EARTH TO PASSAGE	N/A	P-1	P-2	P-3
LIQUID TO PASSAGE	P-2	N/A	P-2	P-4
LIQUID TO EARTH	P-2	N/A	P-2	P-4
PASSAGE TO PASSAGE	P-1	P-1	P-1	P-1
LIQUID TO LIQUID	P-2	N/A	P-2	P-4

P-2 MAY BE USED IN LIEU OF P-1 AND P-3.
P-4 MAY BE USED IN LIEU OF P-3 AND IF CALLED FOR ON THE DRAWINGS P-4 SHALL BE USED IN LIEU OF P-3.

- NOTES:
- WHERE PIPES PASS THROUGH WALLS, FLOORS, OR CEILINGS, THE METHOD USED SHALL CONFORM TO THE STANDARD DETAILS AS SHOWN ON THIS DRAWING, EXCEPT WHERE SPECIAL DETAILS ARE SHOWN.
 - PASSAGE SHALL MEAN ANY ROOM, GALLERY, TUNNEL OR SIMILAR ENCLOSED SPACE IN WHICH PIPES RUN.
 - ALL SLEEVES SHALL BE CAST IRON UNLESS OTHERWISE NOTED.
 - FLANGES MAY BE INSTALLED FLUSH WITH WALL AND TAPPED FOR STUDS.
 - CEMENT GROUT CAULKING MAY BE ELIMINATED FOR PASSAGE TO PASSAGE PENETRATIONS.
 - LIQUID SHALL MEAN AN ELEVATION 1'-6" ABOVE MAXIMUM WATER ELEVATION.

PIPE THROUGH WALLS DETAILS
SCALE: N.T.S.

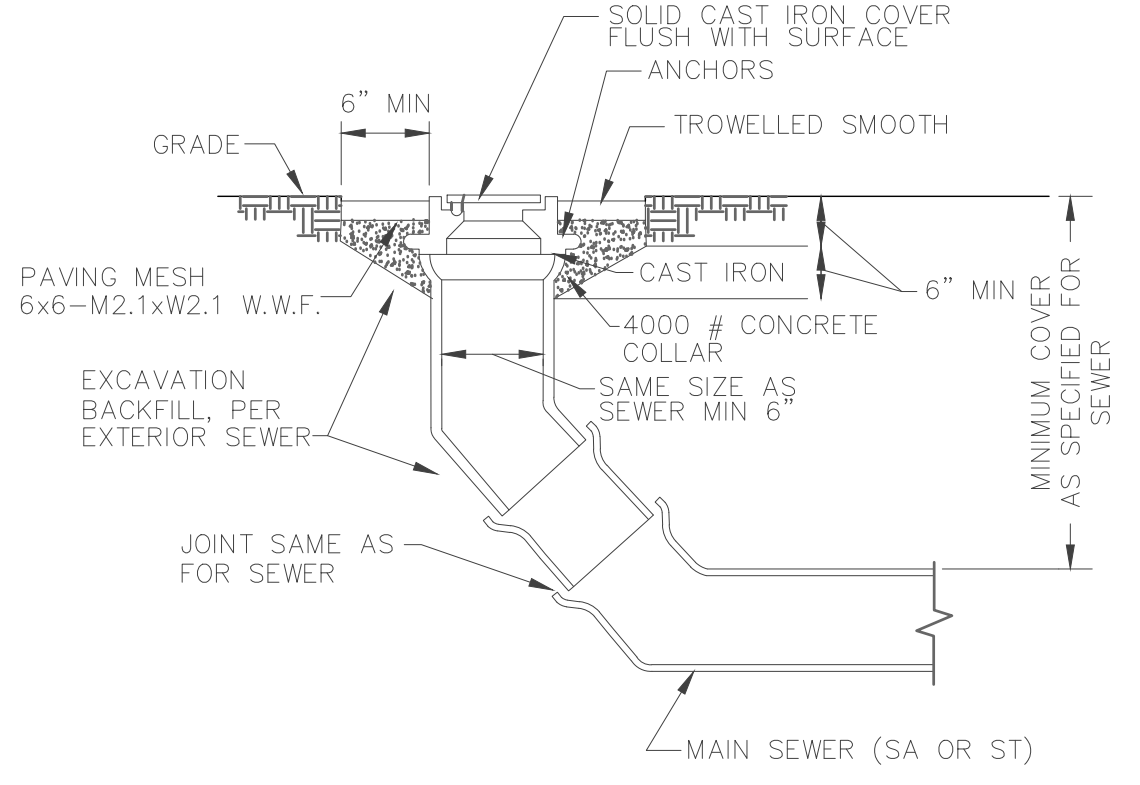

TYPICAL YARD CLEANOUT
SCALE: N.T.S.

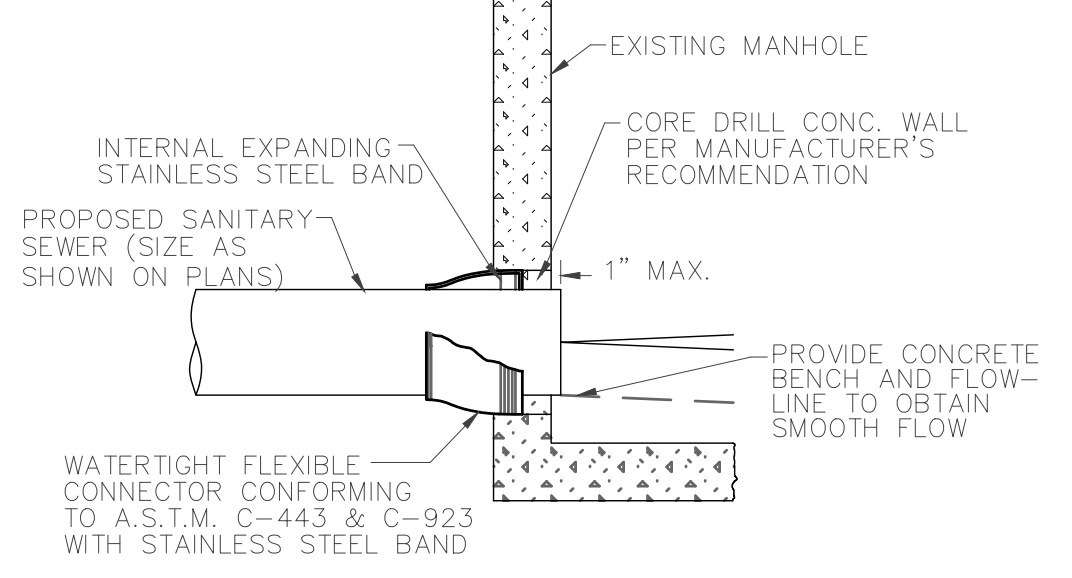

PIPE TO MANHOLE CONNECTION
SCALE: N.T.S.

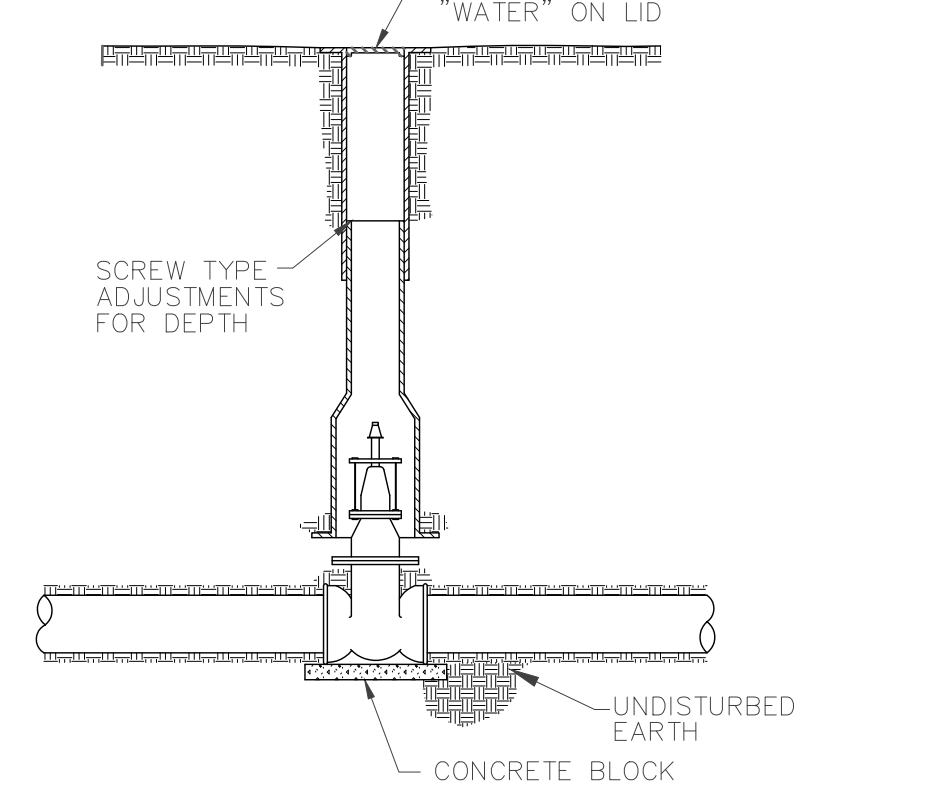

TYPICAL VALVE BOX INSTALLATION
SCALE: N.T.S.

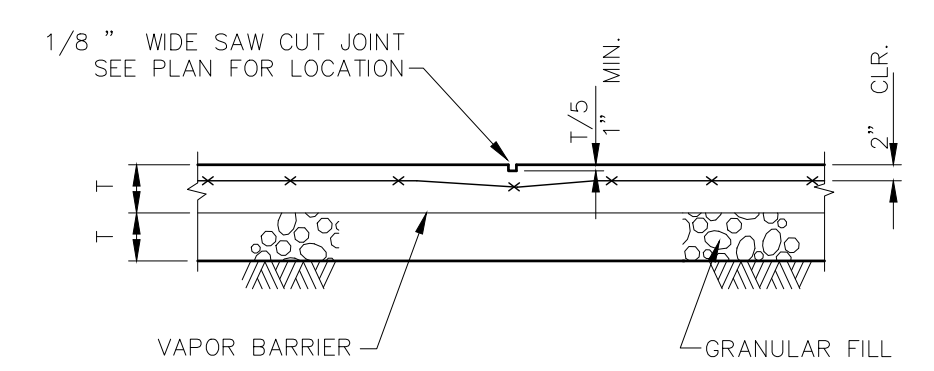

TYPICAL SLAB ON GRADE CONTROL JOINT
SCALE: N.T.S.

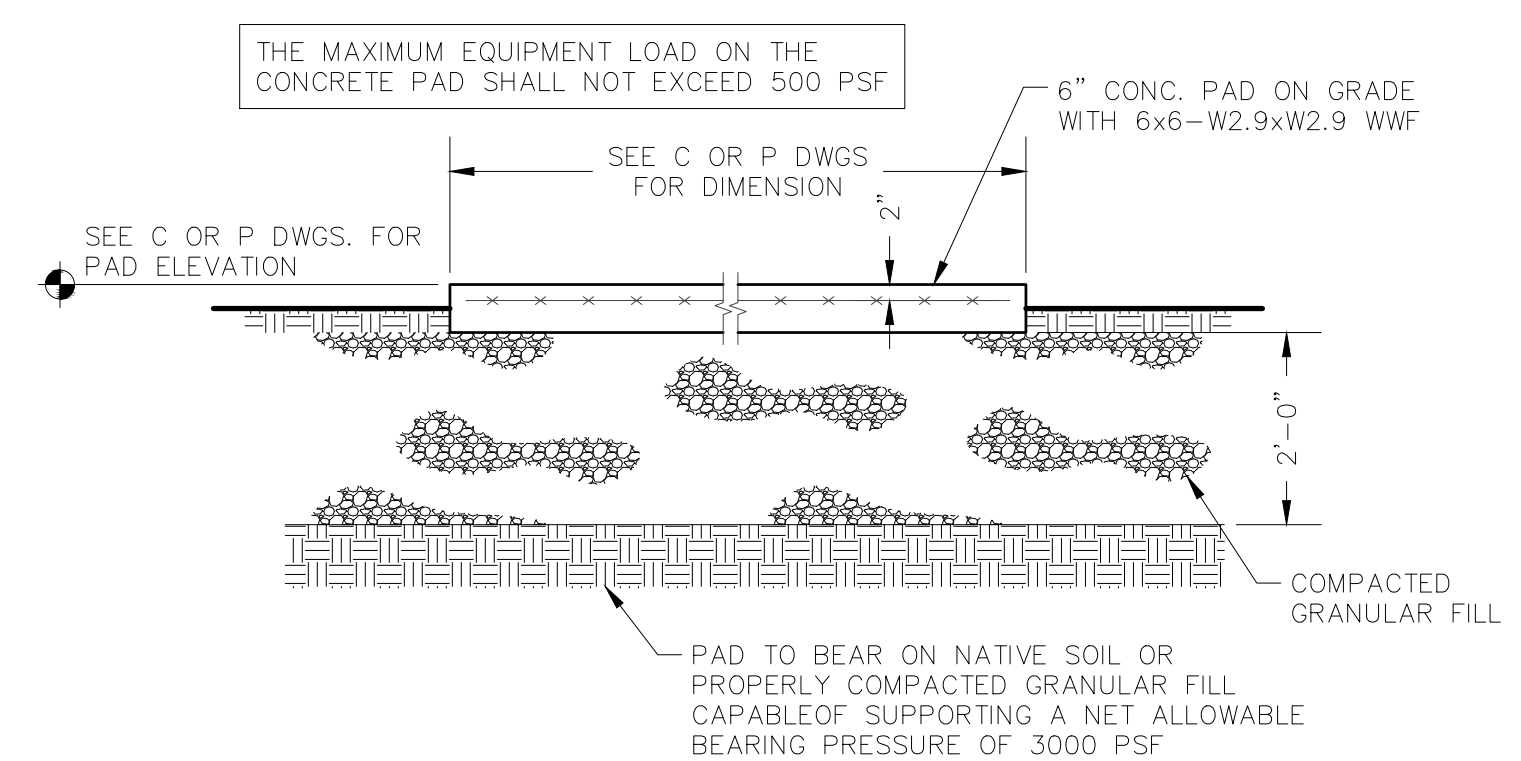

TYPICAL EXTERIOR EQUIPMENT PAD ON GRADE
SCALE: N.T.S.

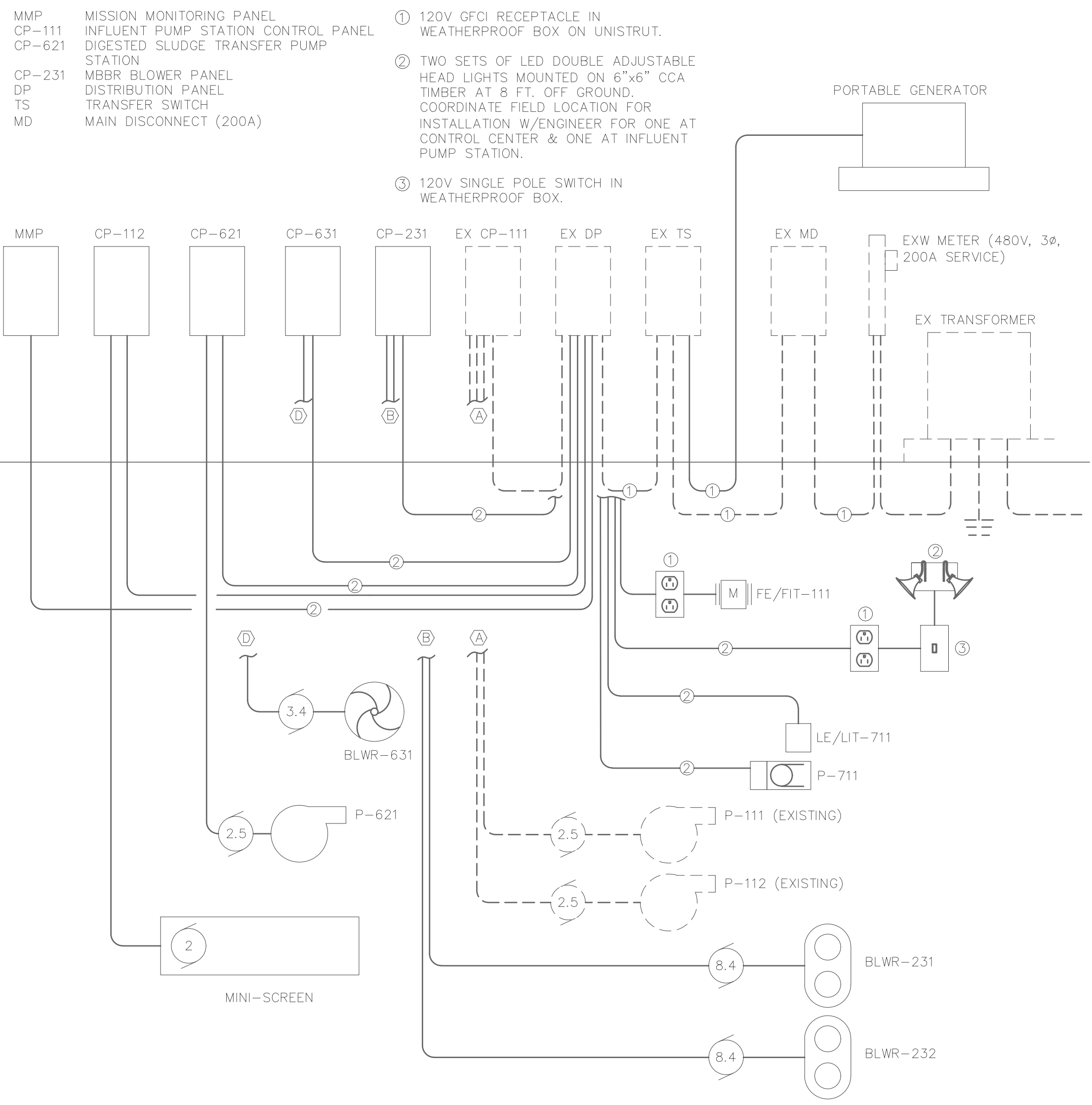

ELECTRICAL RISER DIAGRAM

- MMP MISSION MONITORING PANEL
CP-111 INFLUENT PUMP STATION CONTROL PANEL
CP-621 DIGESTED SLUDGE TRANSFER PUMP STATION
CP-231 MBBR BLOWER PANEL
DP DISTRIBUTION PANEL
TS TRANSFER SWITCH
MD MAIN DISCONNECT (200A)

- 120V GFCI RECEPTACLE IN WEATHERPROOF BOX ON UNISTRUT.
- TWO SETS OF LED DOUBLE ADJUSTABLE HEAD LIGHTS MOUNTED ON 6"x6" CCA TIMBER AT 8 FT. OFF GROUND. COORDINATE FIELD LOCATION FOR INSTALLATION W/ENGINEER FOR ONE AT CONTROL CENTER & ONE AT INFLUENT PUMP STATION.
- 120V SINGLE POLE SWITCH IN WEATHERPROOF BOX.

- ELECTRICAL RISER DIAGRAM NOTES:**
- CONTRACTOR IS REQUIRED TO INSPECT EXISTING ELECTRICAL SYSTEM, VERIFY EXISTING METER SIZE, AND VERIFY WIRE, CONDUCTOR AND CONDUIT SIZING REQUIREMENTS PRIOR TO SUBMITTING BID.
 - CONTRACTOR TO SUBMIT ELECTRICAL LAYOUT AND DESIGN TO ENGINEER FOR APPROVAL PRIOR TO ORDERING MATERIALS.
 - IT IS THE CONTRACTOR'S RESPONSIBILITY TO INSTALL ALL ELECTRICAL EQUIPMENT NECESSARY FOR THE ENTIRE PROJECT INCLUDING ANY TRANSFORMER NEEDS.
 - IT IS THE CONTRACTOR'S RESPONSIBILITY TO INSTALL ALL INSTRUMENTATION AND CONTROL PANELS NECESSARY FOR THE ENTIRE PROJECT.
 - UNISTRUT TO BE PROVIDED AS NEEDED TO INSTALL ALL ELECTRICAL AND CONTROL PANEL EQUIPMENT.
 - ALL CONDUIT SHALL BE SIZED AND PROVIDED BY CONTRACTOR. CONDUIT AND CONDUIT SIZING SHALL MEET ALL NEC CODE REQUIREMENTS FOR ABOVE AND BELOW GRADE INSTALLATION.
 - ALL WIRE AND CONDUCTORS SHALL BE ENCLOSED IN CONDUIT.
 - ALL WIRE SHALL BE COPPER EXCEPT ALUMINUM WILL BE ALLOWED UP TO THE DISTRIBUTION PANEL.

- REMOTE WIRELESS MONITORING AND CONTROL REQUIREMENTS:**
- REMOTE WIRELESS MONITORING UNIT SHALL BE M850 SERIES UNIT PROVIDED BY MISSION COMMUNICATIONS (SALES REPRESENTATIVE IS JEFF CLARKE WITH HYDRO-KINETICS; 314-647-6104).

- DIGITAL INPUTS
 - P-111 RUN; P-111 FAIL
 - P-112 RUN; P-112 FAIL
 - P-621 RUN; P-621 FAIL
 - P-461 RUN; P-461 FAIL
 - P-711 RUN; P-711 FAIL
 - BLWR-631 RUN; BLWR-631 FAIL
 - BLWR-232 RUN; BLWR-232 FAIL
- ANALOGUE INPUTS
 - FE/FIT-111 FLOW (INFLUENT METER)
 - LE/LIT-711 (PAA STORAGE LEVEL)
 - BLWR-631 SPEED
 - BLWR-231 SPEED
 - BLWR-232 SPEED

REV	DATE	DESCRIPTION
1	12/27/2021	PERMIT SET

DESIGN GROUP INC.
1351 Jefferson, Suite 301
Washington, MO 63090
mail@designgroup.net
P: 636-492-2622

PROCESS DETAILS AND ELECTRICAL RISER DIAGRAM
TIMBERLAND WWTF
6500 U.S. 60 WEST
PADUCAH, KY

ENGINEERING CERTIFICATE OF AUTHORITY NO. 4808
ENGINEERING LICENSE: BENJAMIN J. KUENZEL, PE33718

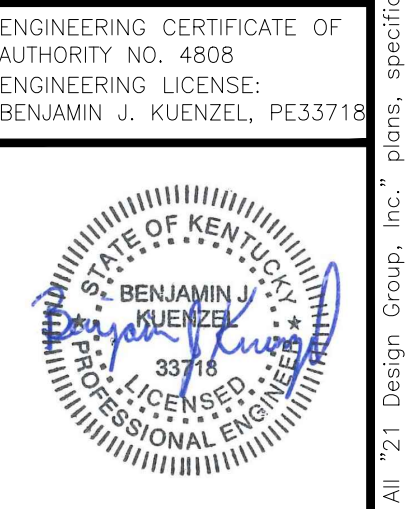

SEAL DATE	1/27/2021
DRAWN BY	DDG
PROJ NUMBER	0542-19
DATE	12/23/2020
DRAWING NO	P9

ALL RIGHTS RESERVED. All 21 Design Group, Inc., plans, specifications and drawings are protected under copyright law and no part may be copied, reproduced, displayed publicly, used to create derivatives, distributed, stored in a retrieval system or transmitted in any form by any means without prior written permission of 21 Design Group, Inc.