



# MEET JAC

The M501JAC Gas Turbine Decarbonizing Power  
Tested, proven, the most reliable.

## MITSUBISHI POWER'S J-SERIES AIR COOLED (JAC)



**99.5%+ Reliability**  
Validated with 8,000  
actual operating hours



**>64% Efficiency**  
Industry leading efficiency



**Hydrogen Ready**  
For renewables integration

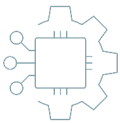

**A.I. Enabled**  
TOMONI™ total plant intelligent  
solutions for operational flexibility



**Constructability Optimized**  
Improved constructability reduces  
construction time and cost



**Long-Term Service  
Agreements**  
Local support through entire lifecycle



© 2022 Mitsubishi Power Americas, Inc. All Rights Reserved.

25

# Hydrogen-Fired DLN Gas Turbine Combustor Development



**Current DLN combustor can Operate up to 30% Hydrogen**

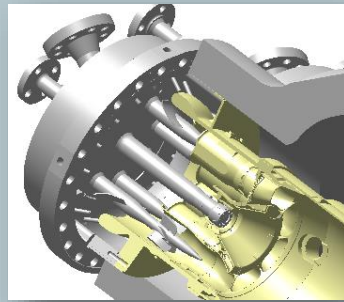

**Multi-Cluster Technology Will Operate on 100% Hydrogen**

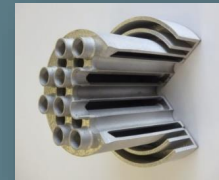
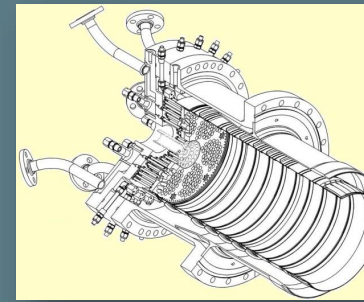

3D Printed Part



**Two DLN combustor technologies that can operate on hydrogen and achieve ultra-low plant emissions levels**