

Isometric

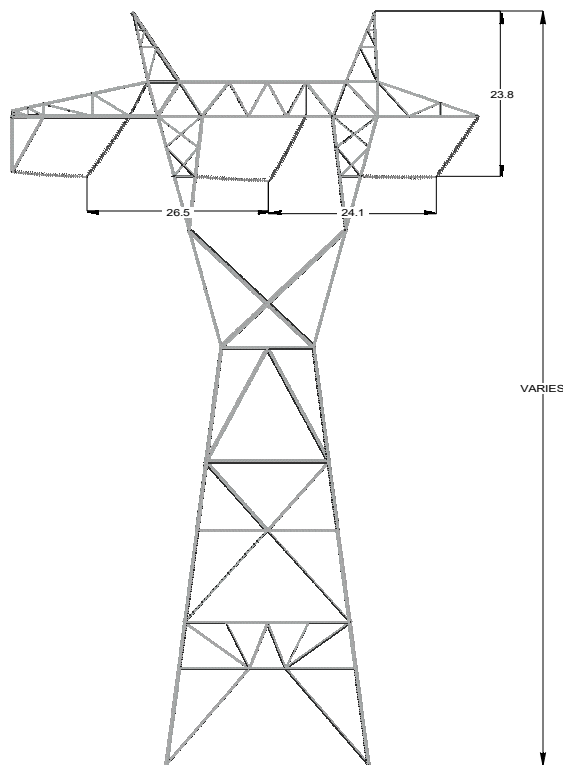

Longitudinal

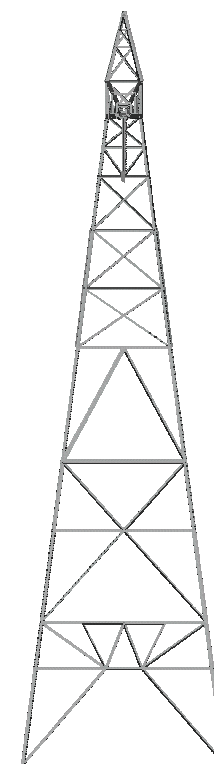

Transverse

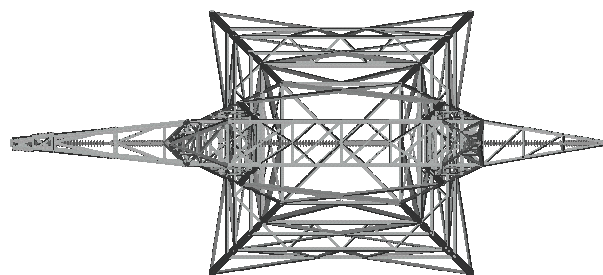

Plan

SURVEY BY

SCALES

REVISED BY DATE

SURVEY BY:
CHECKED BY:

DATE:

3CS TOWER

UNIT NO.:



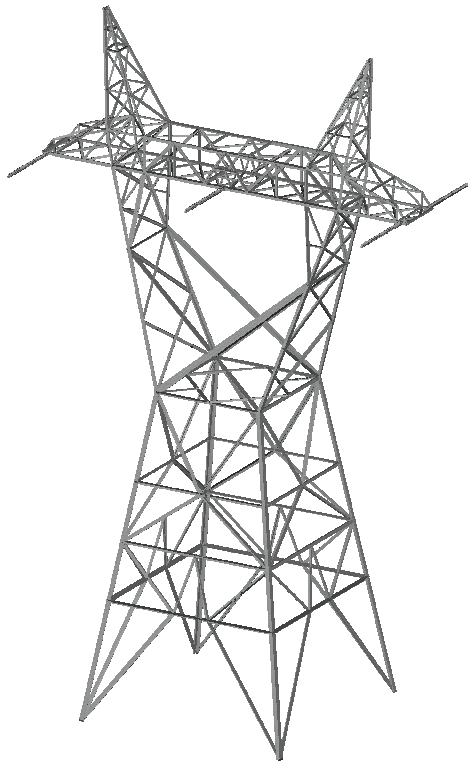

Isometric

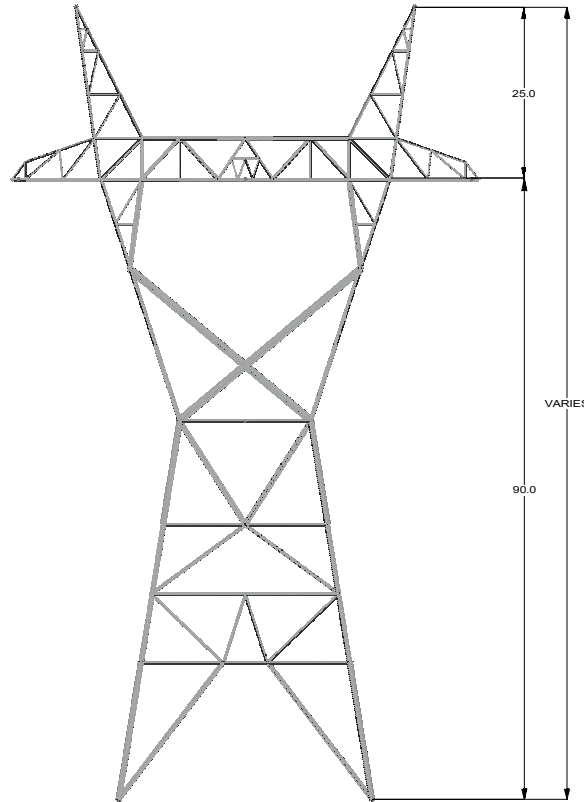

Longitudinal

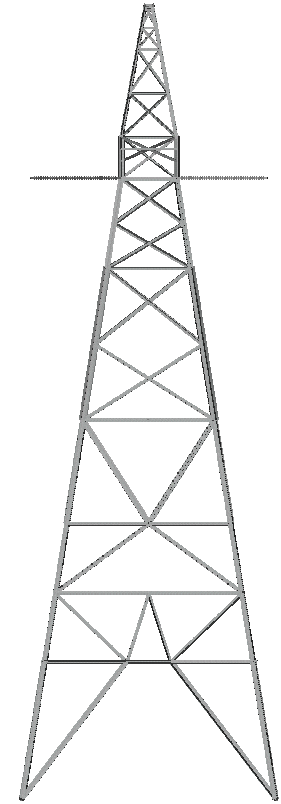

Transverse

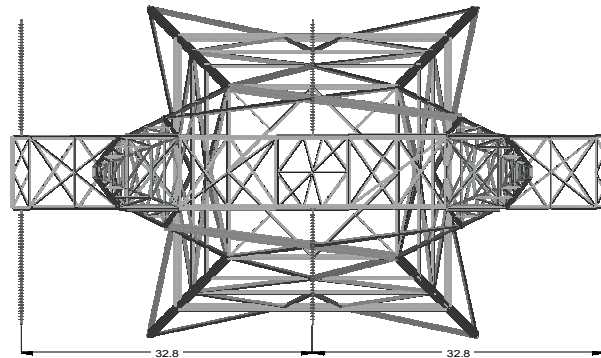

Plan

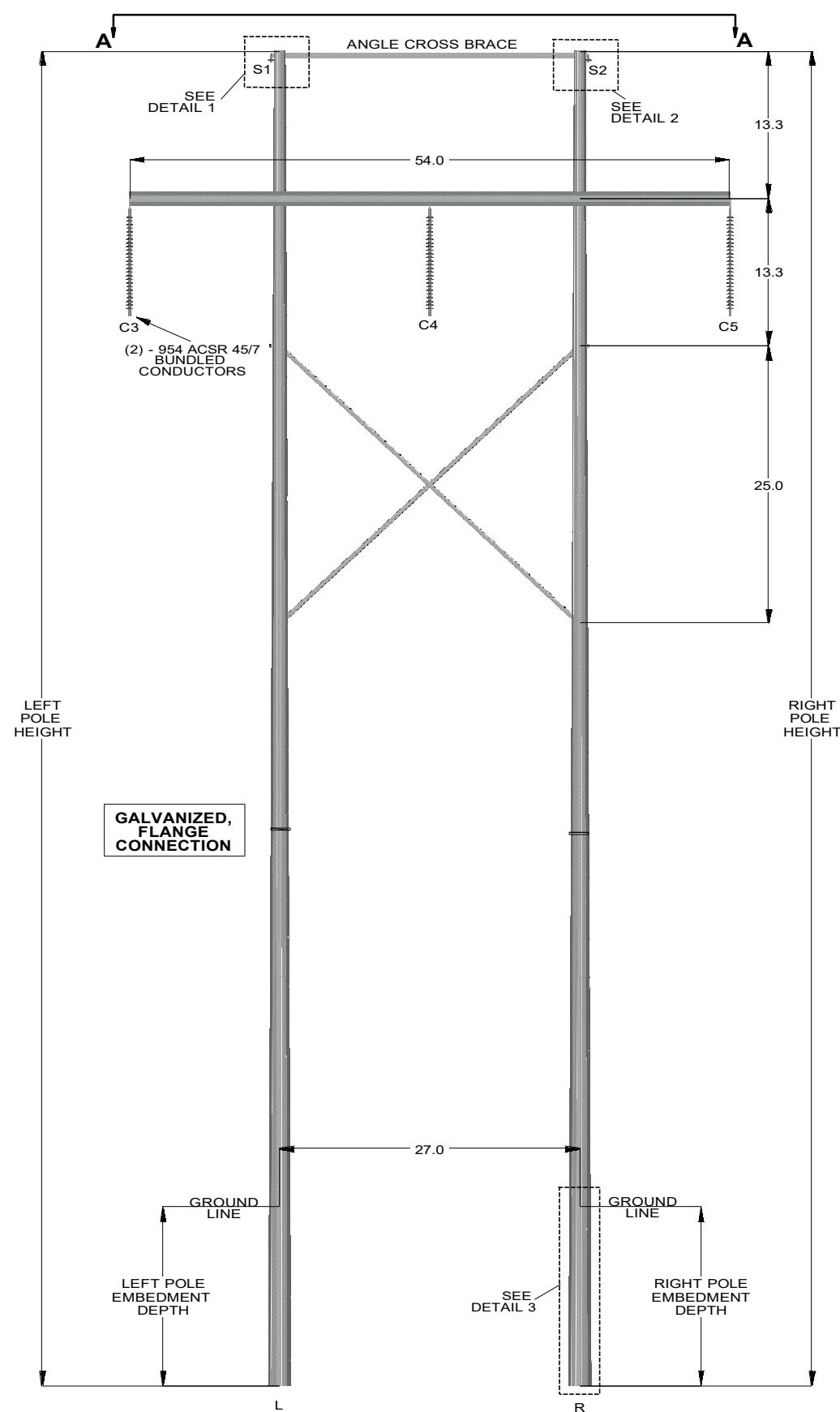

345KV TANGENT H-FRAME

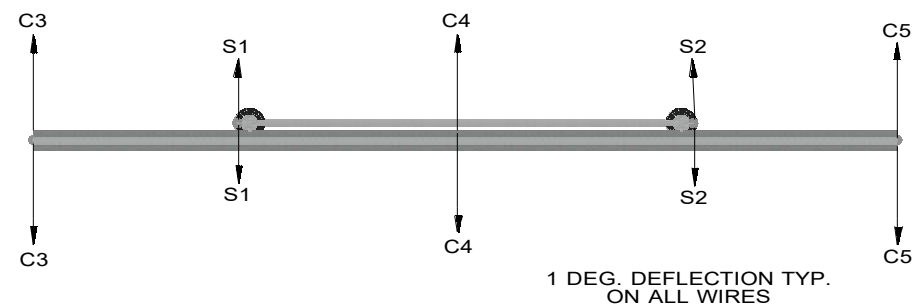

SECTION A-A

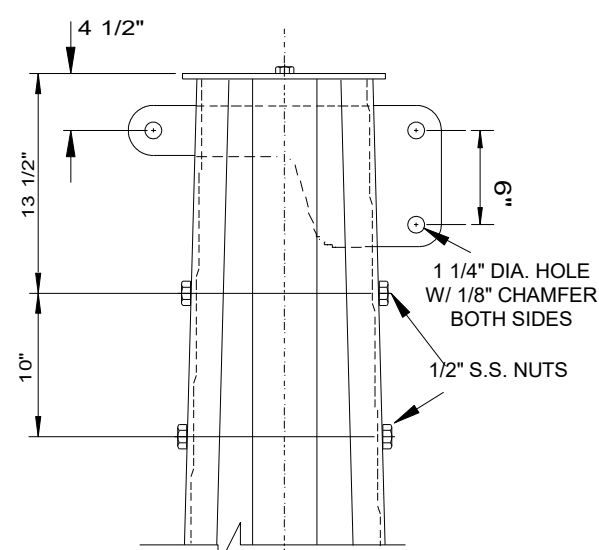

DETAIL 1 - LEFT POLE TOP

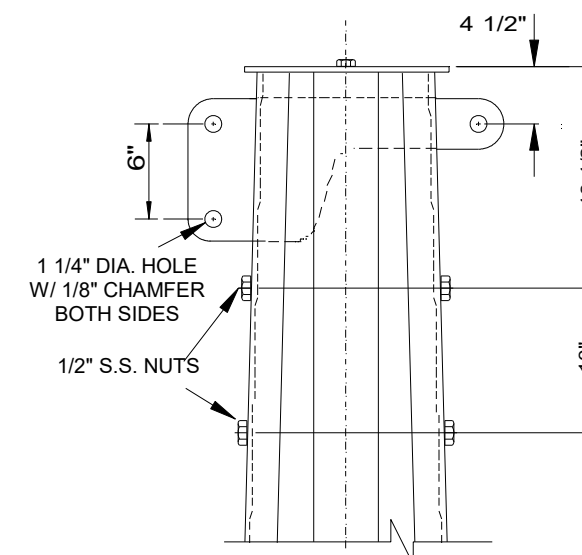

DETAIL 2 - RIGHT POLE TOP

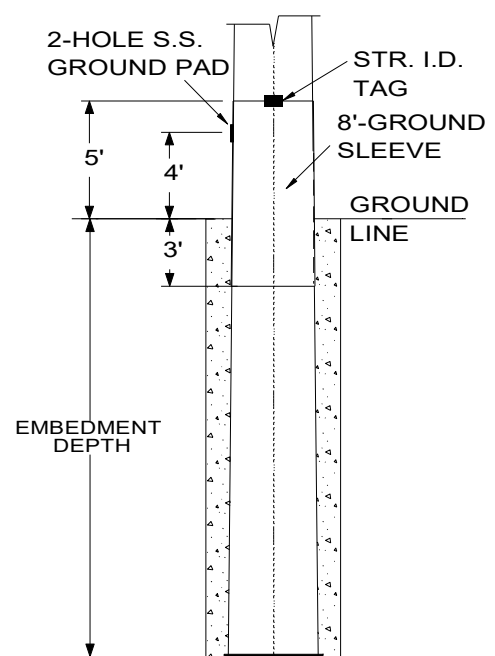

DETAIL 3 - RIGHT POLE BOTTOM

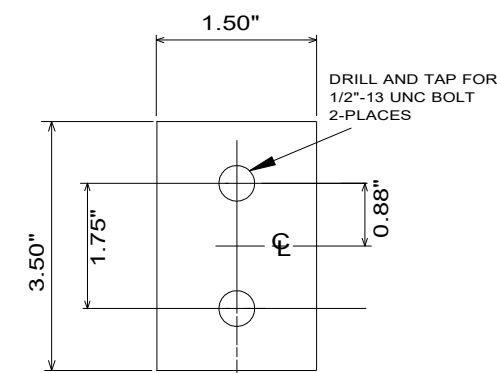

DETAIL 4 - TYP. GROUND PAD



Project: LI-167000	Drawn: KEM	Checked:	Approved:
-----------------------	---------------	----------	-----------

HARDIN COUNTY - GLENDALE SOUTH 345KV

345KV 27-FT TANGENT H-FRAME
GLENDALE FORD PROJECT
WEST ROUTE

Scale: NTS	Drawing Number:
------------	-----------------

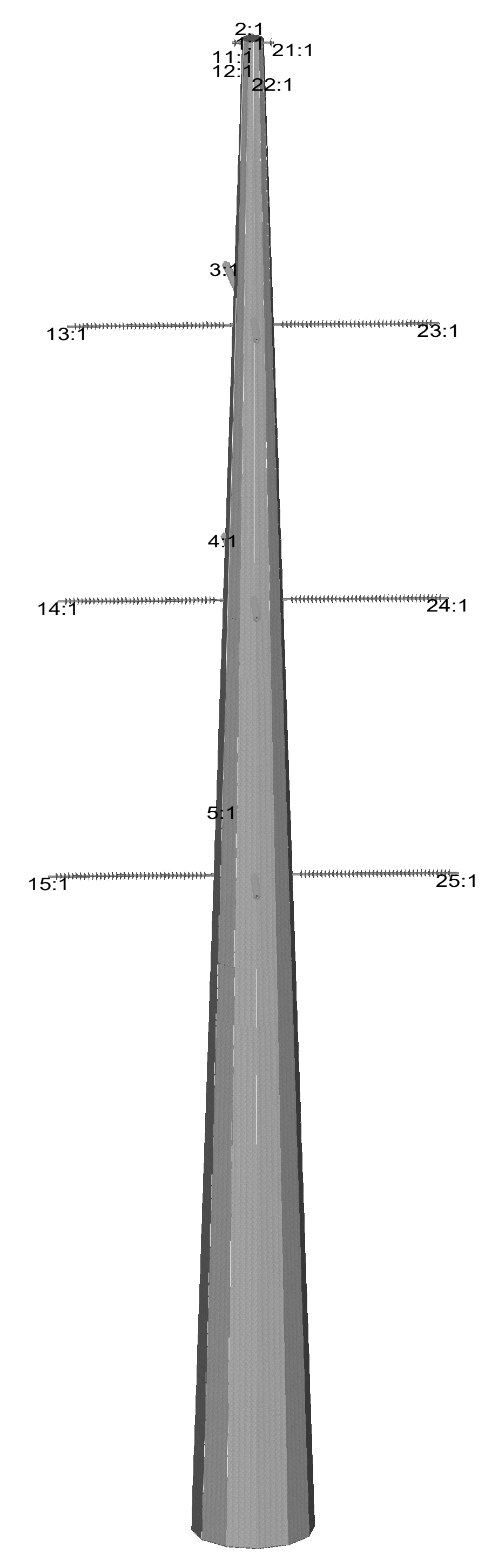
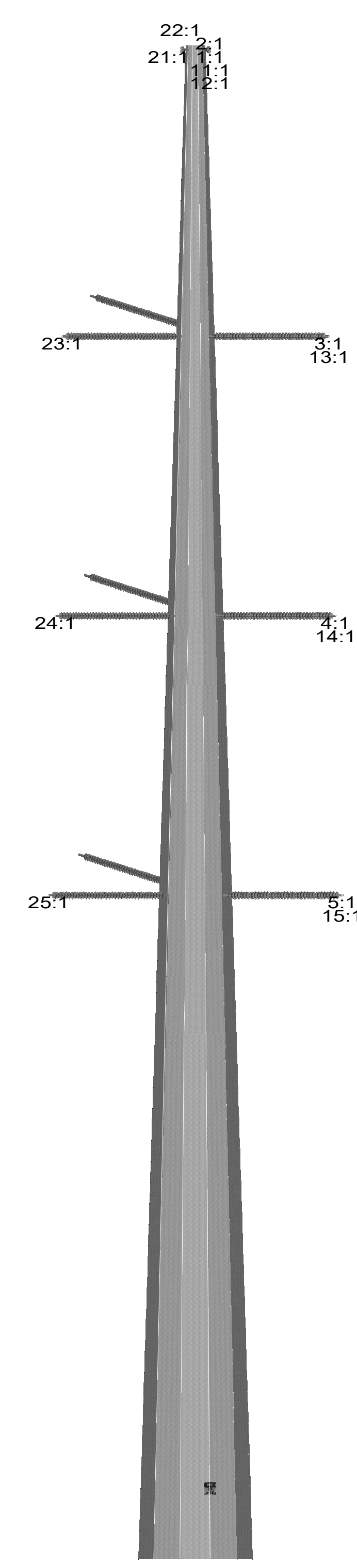
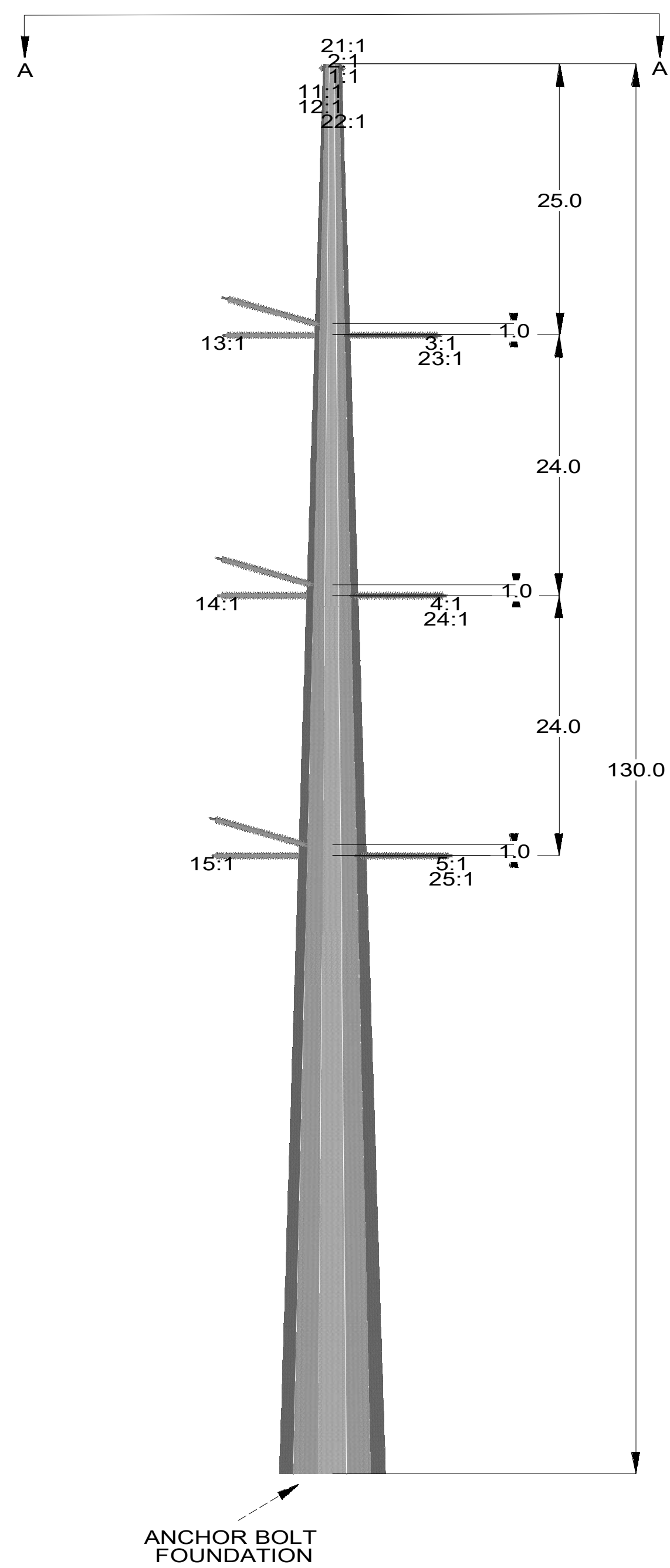
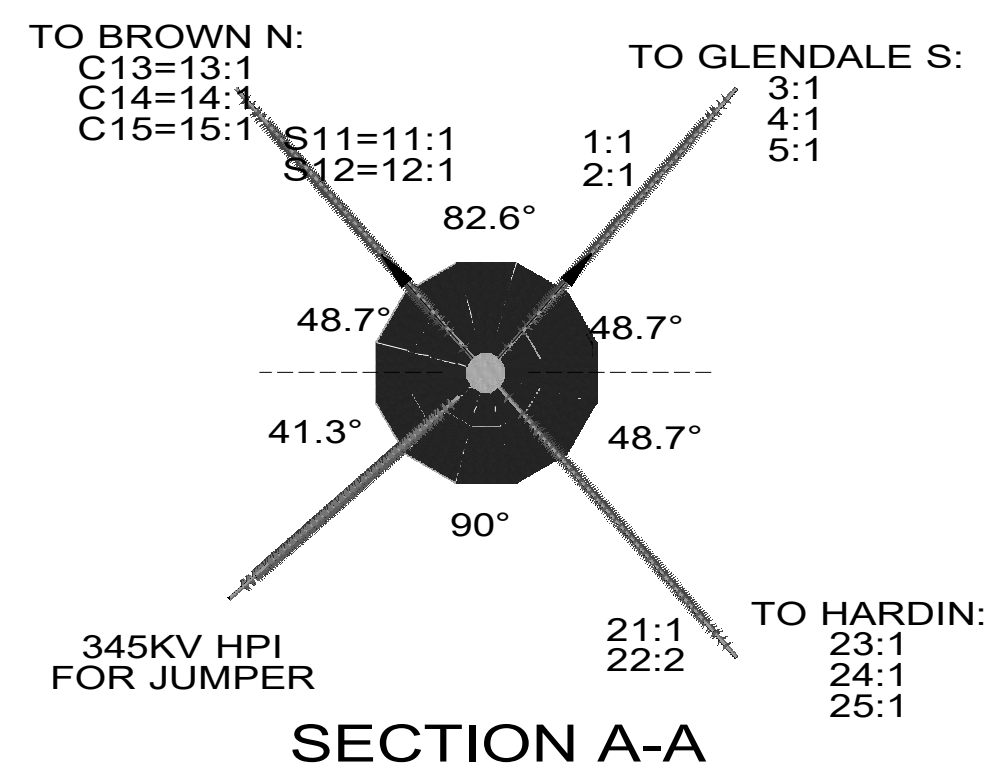

WIRE CHART		
WIRE NO.	WIRE	DEF. ANGLE
1	0.528" OPGW	A-A
2	7#8 ALWD	A-A
3	2- 954 ACSR 45/7 BUNDLED	A-A
4	2- 954 ACSR 45/7 BUNDLED	A-A
5	2- 954 ACSR 45/7 BUNDLED	A-A
11	7#8 ALWD	A-A
12	7#8 ALWD	A-A
13	2- 954 ACSR 45/7 BUNDLED	A-A
14	2- 954 ACSR 45/7 BUNDLED	A-A
15	2- 954 ACSR 45/7 BUNDLED	A-A
21	7#8 ALWD	A-A
22	7#8 ALWD	A-A
23	2- 954 ACSR 45/7 BUNDLED	A-A
24	2- 954 ACSR 45/7 BUNDLED	A-A
25	2- 954 ACSR 45/7 BUNDLED	A-A

CABLE PROPERTIES		
WIRE	DIAMETER (in)	UNIT WEIGHT (lbs/ft)
AFL DNO-11268 OPGW	0.528	0.388
7#8 ALWD	0.385	0.262
2-954 ACSR 45/7 BUNDLED	1.165 X 2	1.074 x 2



Project: LI-167444 Drawn: NAP Checked: Approved:

GLENDALE S - BROWN N 345KV LINE

STRUCTURE #16
 130' SELF-SUPPORTING
 DEADEND STRUCTURE

Scale: NTS Drawing Number: STR16-P1

CASE 1:	NEC HEAVY LOADING 1/2" ICE, 4 PSF WIND AT 0° F 10 PSF ON POLE 1.5 X STR. WT + DOWN LOAD	WIRE O.L.F: TRANS. 2.5 LONG. 1.65 VERT. 1.5
CASE 2:	EXTREME WIND (90 MPH) 21 PSF AT 60°F, NO ICE (INITIAL) 26.25 PSF ON POLE 1.25 X STR. WT + DOWN LOAD	WIRE O.L.F: TRANS. 1.1 LONG. 1.1 VERT. 1.1
CASE 3:	EXTREME ICE WITH WIND 1" ICE, 2.31 PSF WIND AT 15°F 2.90 PSF ON POLE 1.1 X STR. WT. + DOWN LOAD	WIRE O.L.F: TRANS. 1.1 LONG. 1.1 VERT. 1.1
CASE 4:	EXTREME ICE 1" ICE, NO WIND AT 32°F 0 PSF ON POLE 1.1 X STR. WT. + DOWN LOAD	WIRE O.L.F: TRANS. 1.1 LONG. 1.1 VERT. 1.1
CASE 5:	STRINGING LOAD NO ICE, NO WIND, 0°F 0 PSF ON POLE 1.1 X STR. WT. + DOWN LOAD	WIRE O.L.F: TRANS. 1.1 LONG. 1.1 VERT. 1.1
CASE 6:	CAMBER/DEFLECTION LOAD NO ICE, NO WIND, 60°F 1.1 X STR. WT. + DOWN LOAD	WIRE O.L.F: TRANS. 1.1 LONG. 1.1 VERT. 1.1

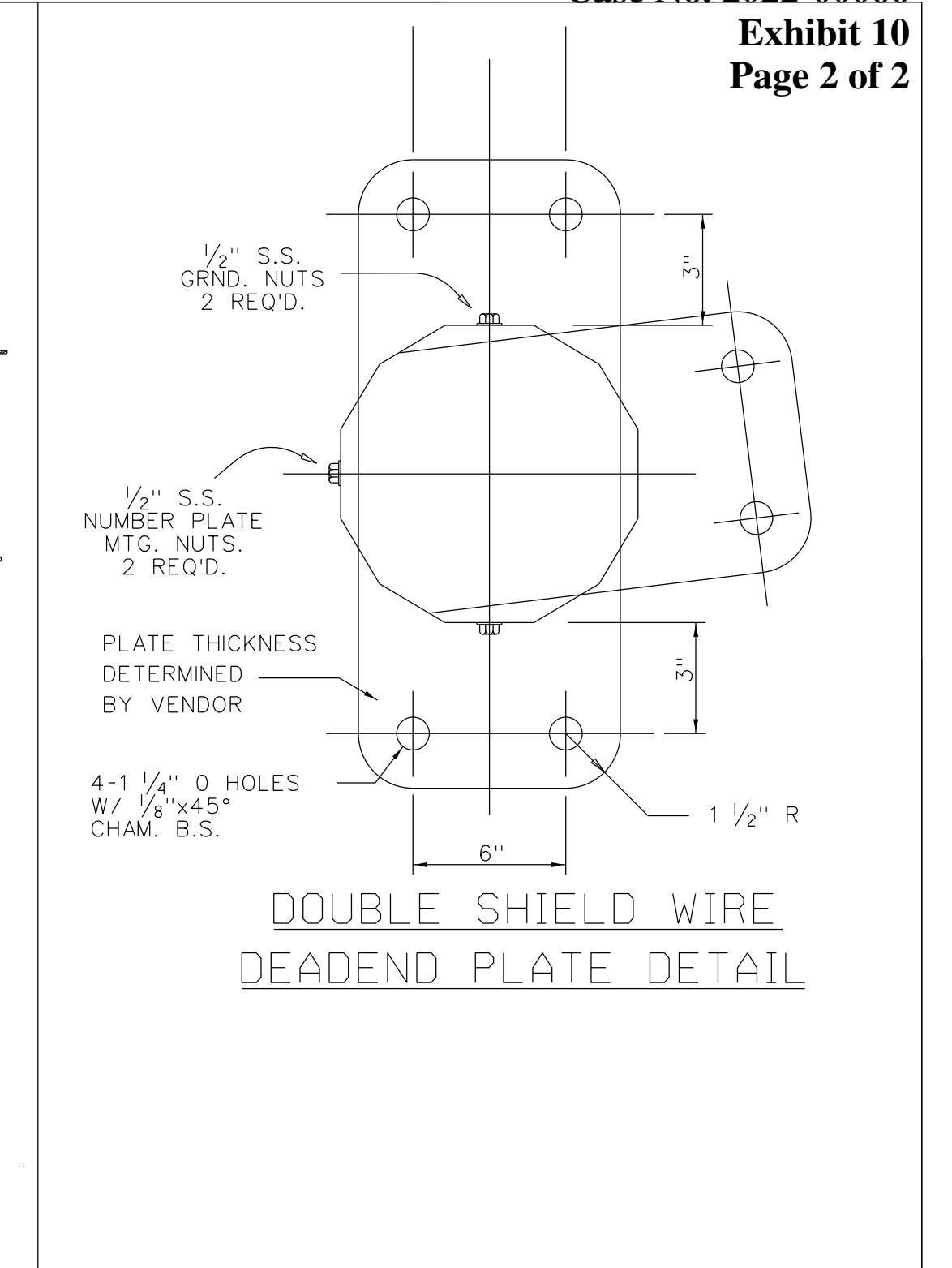
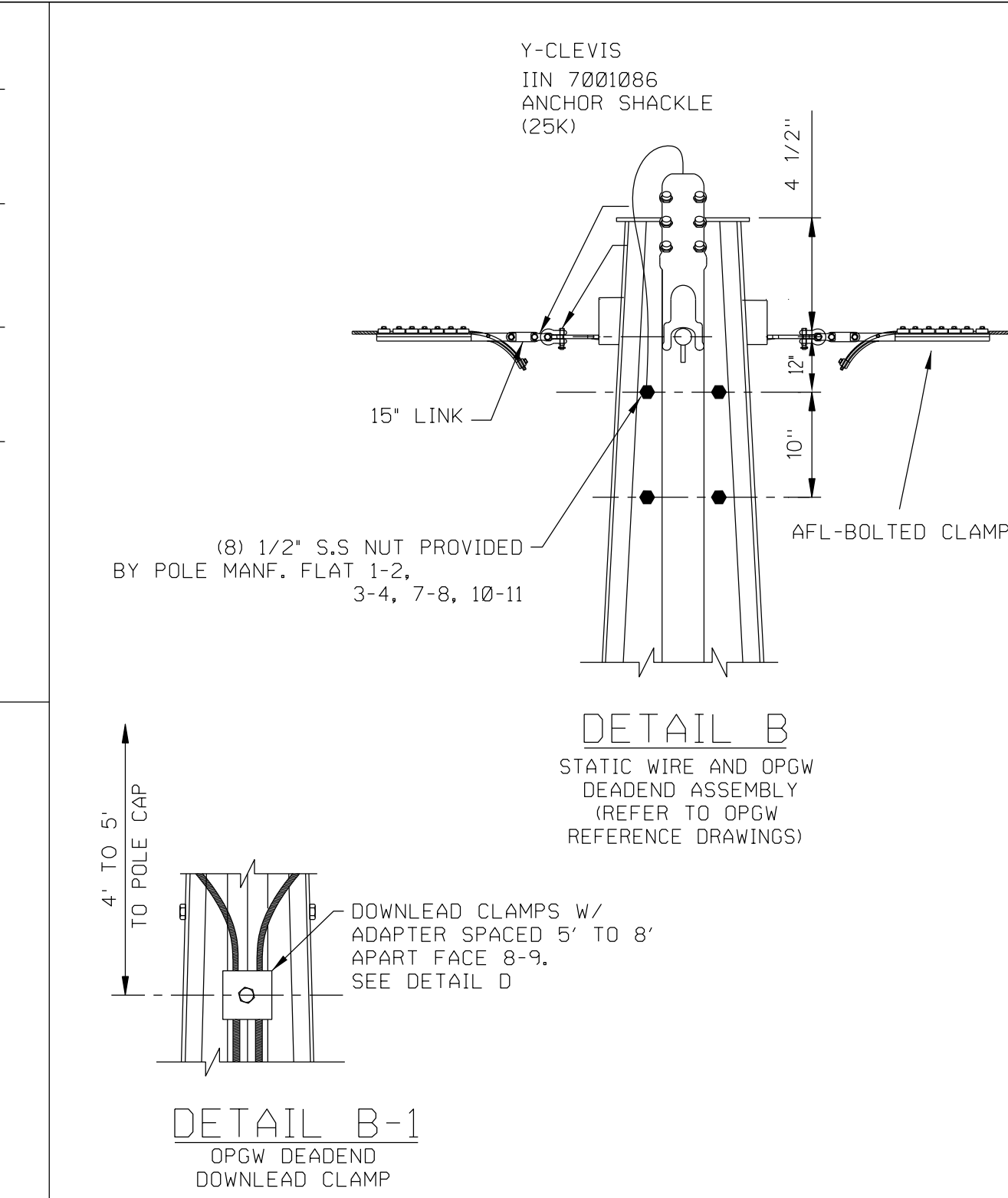
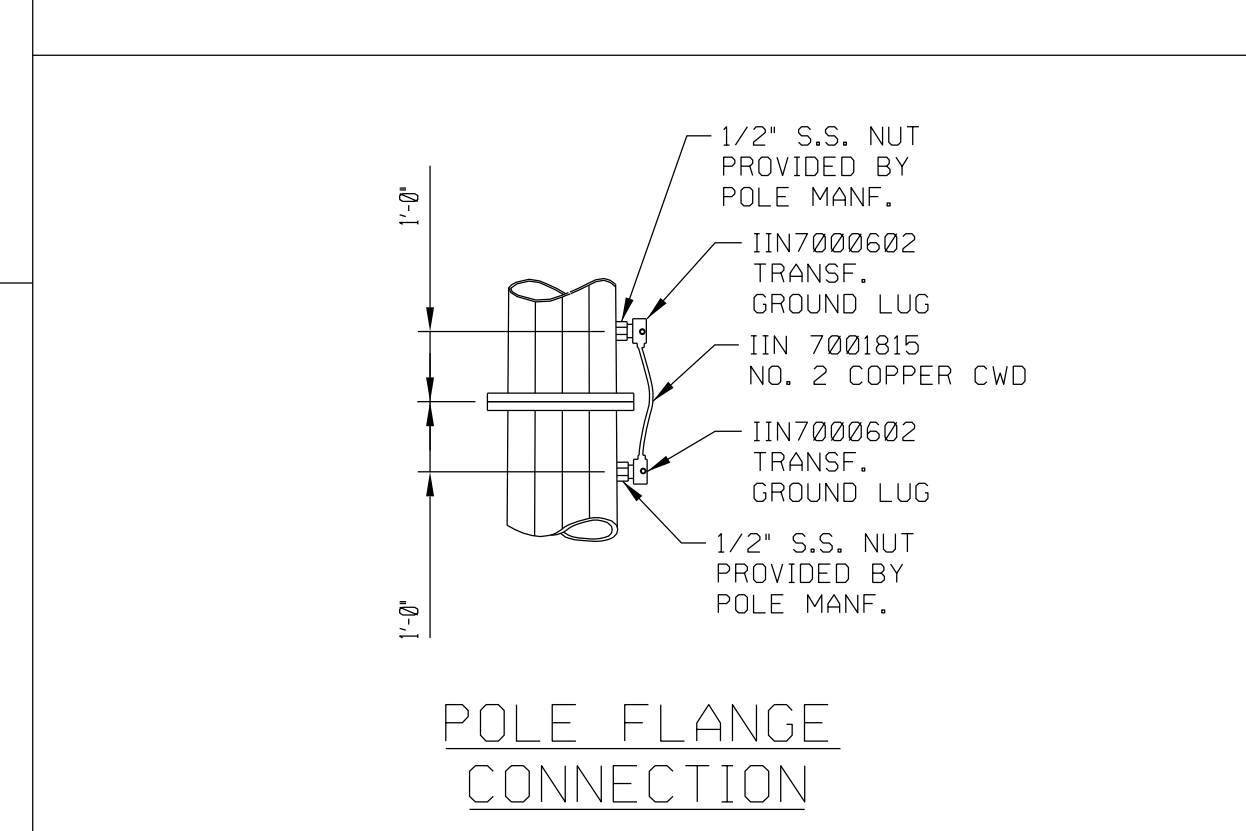
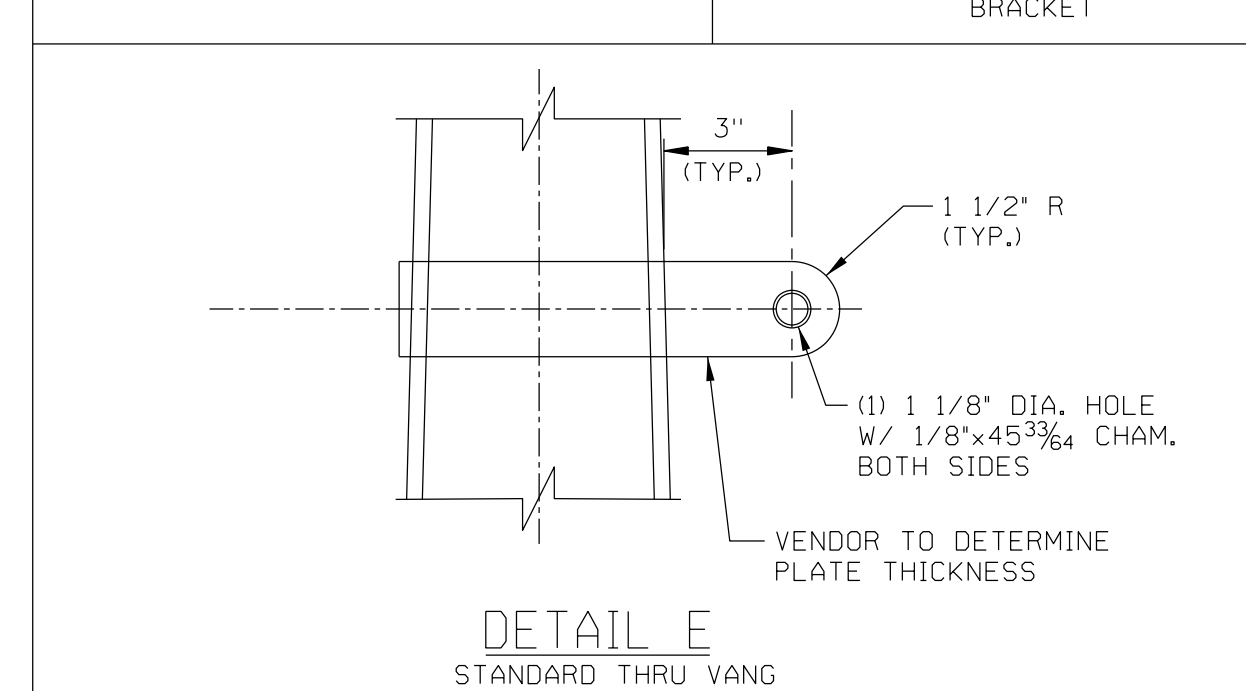
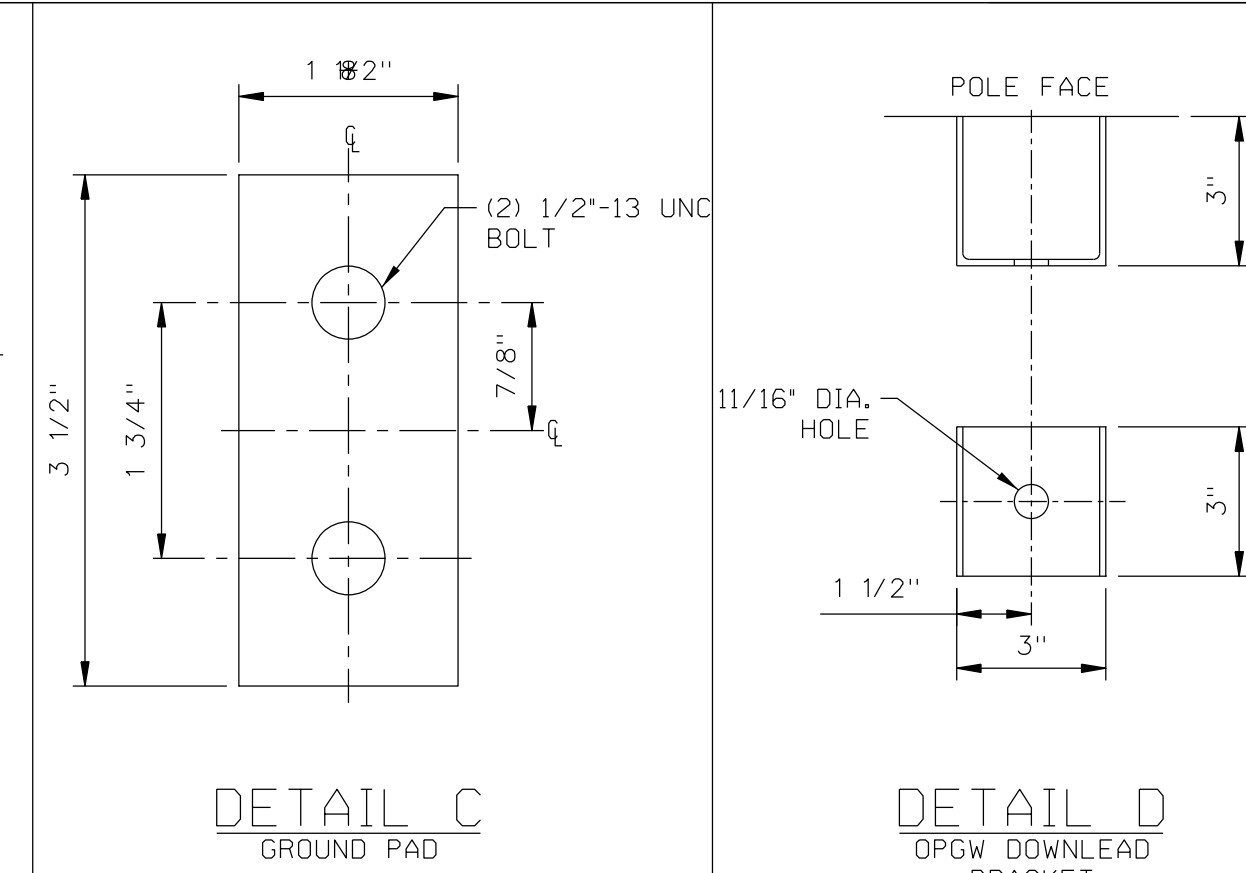
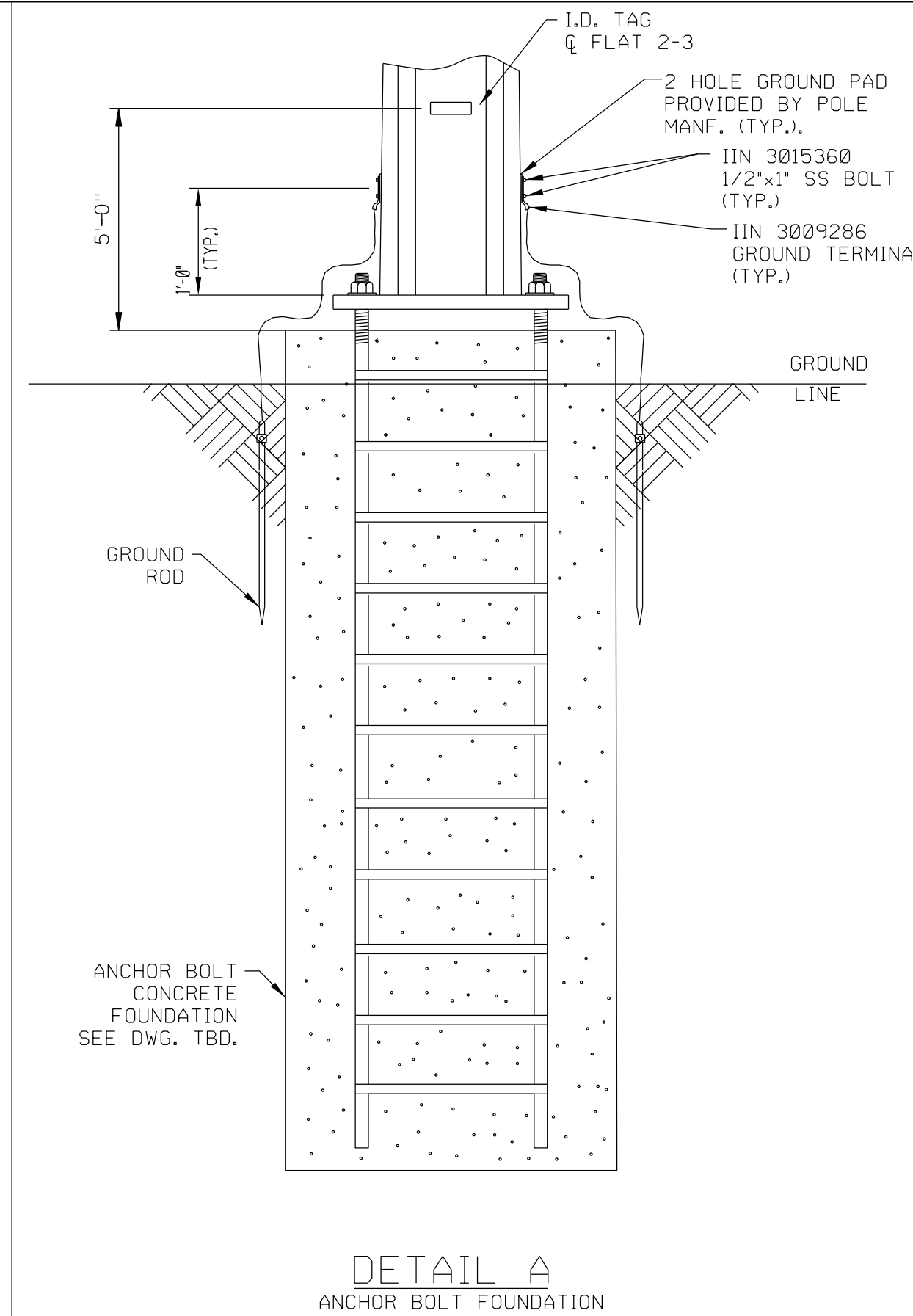

STRUCTURE 16-TEMPORARY										
WIRE NO.	WIRE DESCRIPTION	WIRE DEFLECTION ANGLE (DEG)	WIND SPAN (FT)	WEIGHT SPAN (FT)	CASE 1: SESC HEAVY INITIAL DESIGN TENSION (LBS)	CASE 2: EXTREME WIND DESIGN TENSION (LBS)	CASE 3: EXTREME ICE WITH WIND DESIGN TENSION (LBS)	CASE 4: EXTREME ICE DESIGN TENSION (LBS)	CASE 5: STRINGING LOAD (LBS)	CASE 6: CAMBER LOAD (LBS)
S1	0.528" OPGW	A-A	120	500	2050	1300	2800	2700	800	600
S2	7#8 ALWD	A-A	120	500	1650	950	2350	2250	500	400
C3,C4,C5	954 ACSR 45/7 (BUNDLED)	A-A	120	550	6000	3800	6850	6400	4450	2250
S11	7#8 ALWD	A-A	320	500	3350	1950	4750	4600	1050	900
S12	7#8 ALWD	A-A	320	500	3350	1950	4750	4600	1050	900
C13,C14,C15	954 ACSR 45/7 (BUNDLED)	A-A	320	450	7800	5900	10150	9800	4100	3350
S21	7#8 ALWD	A-A	1330	1730	6850	4350	9050	8850	3600	2900
S22	7#8 ALWD	A-A	1330	1730	6850	4350	9050	8850	3600	2900
C23,C24,C25	954 ACSR 45/7 (BUNDLED)	A-A	1330	1700	13500	10500	16900	16600	8750	7200

STRUCTURE 16-PERMANENT										
WIRE NO.	WIRE DESCRIPTION	WIRE DEFLECTION ANGLE (DEG)	WIND SPAN (FT)	WEIGHT SPAN (FT)	CASE 1: SESC HEAVY INITIAL DESIGN TENSION (LBS)	CASE 2: EXTREME WIND DESIGN TENSION (LBS)	CASE 3: EXTREME ICE WITH WIND DESIGN TENSION (LBS)	CASE 4: EXTREME ICE DESIGN TENSION (LBS)	CASE 5: STRINGING LOAD (LBS)	CASE 6: CAMBER LOAD (LBS)
S1	0.528" OPGW	A-A	120	500	2050	1300	2800	2700	800	600
S2	7#8 ALWD	A-A	120	500	1650	950	2350	2250	500	400
C3,C4,C5	954 ACSR 45/7 (BUNDLED)	A-A	120	550	6000	3800	6850	6400	4450	2250
S11	7#8 ALWD	A-A	320	500	3350	1950	4750	4600	1050	900
S12	7#8 ALWD	A-A	320	500	3350	1950	4750	4600	1050	900
C13,C14,C15	954 ACSR 45/7 (BUNDLED)	A-A	320	450	7800	5900	10150	9800	4100	3350

NOTES:

- POLE SHALL HAVE A FLANGE CONNECTION.
- POLE AND ALL ATTACHMENTS SHALL RECEIVE A GALVANIZED FINISH.
- POLE SHALL BE CAMBERED IF POLE TOP DEFLECTION, WITH CAMBER LOADS APPLIED, EXCEED 1% OF POLE HEIGHT, CAMBER LOAD SHALL RECEIVED AN OLF OF 1.10. SEE SECTION 5.00 IN SPECIFICATIONS.
- PROVIDE LIFTING VANGS
- PROVIDE ANCHOR BOLTS.
- PROVIDE STEP BOLTS STARTING AT 12' ABOVE GROUND LINE.
- DESIGN POLE FOR TERMINAL DEADEND LOAD:
 - WITH ONLY WIRES S1,S2,C3,C4,C5 ATTACHED FOR LOAD CASES 1-4.
 - WITH ONLY WIRES S11,S12,C13,C14,C15 ATTACHED FOR LOAD CASES 1-4.

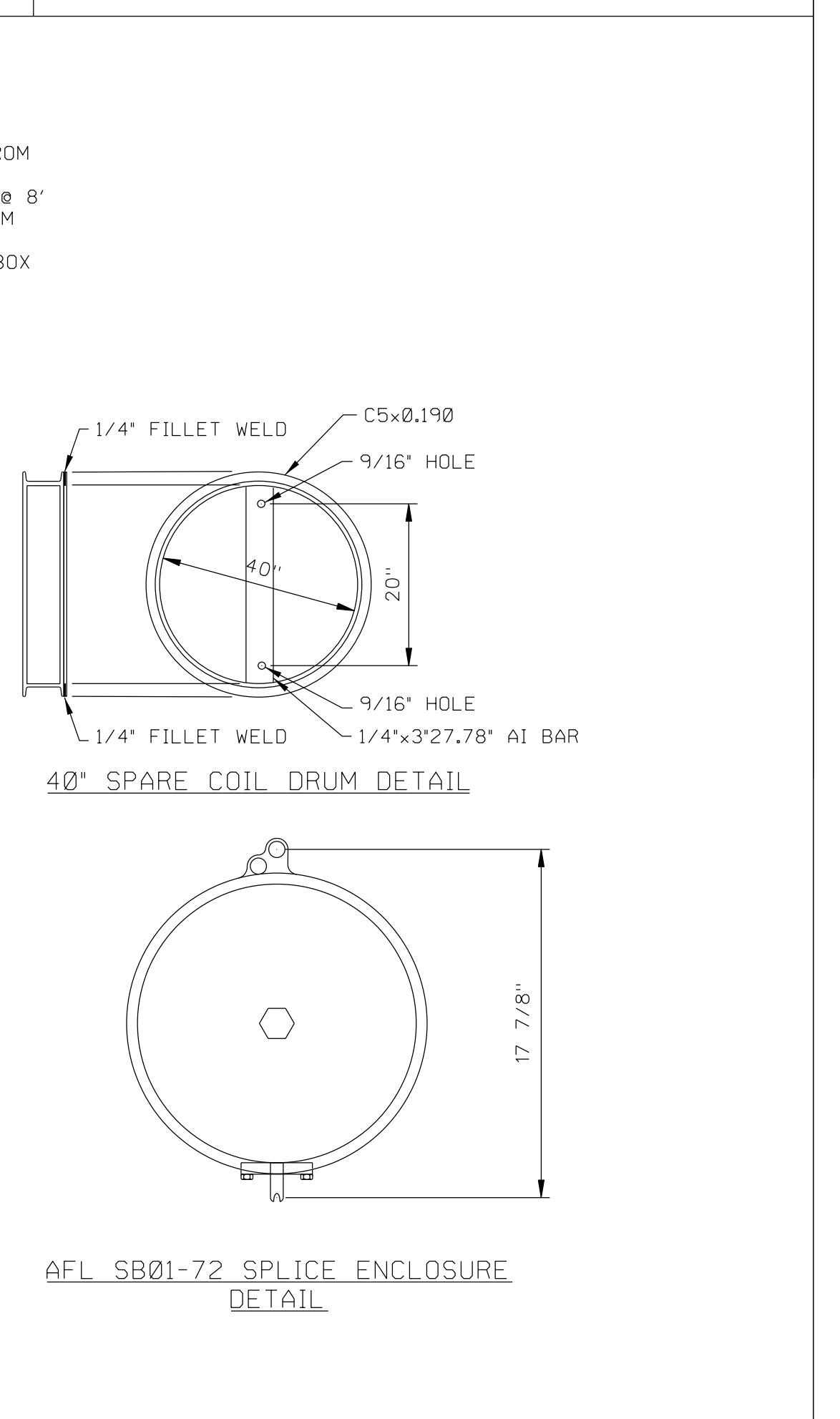
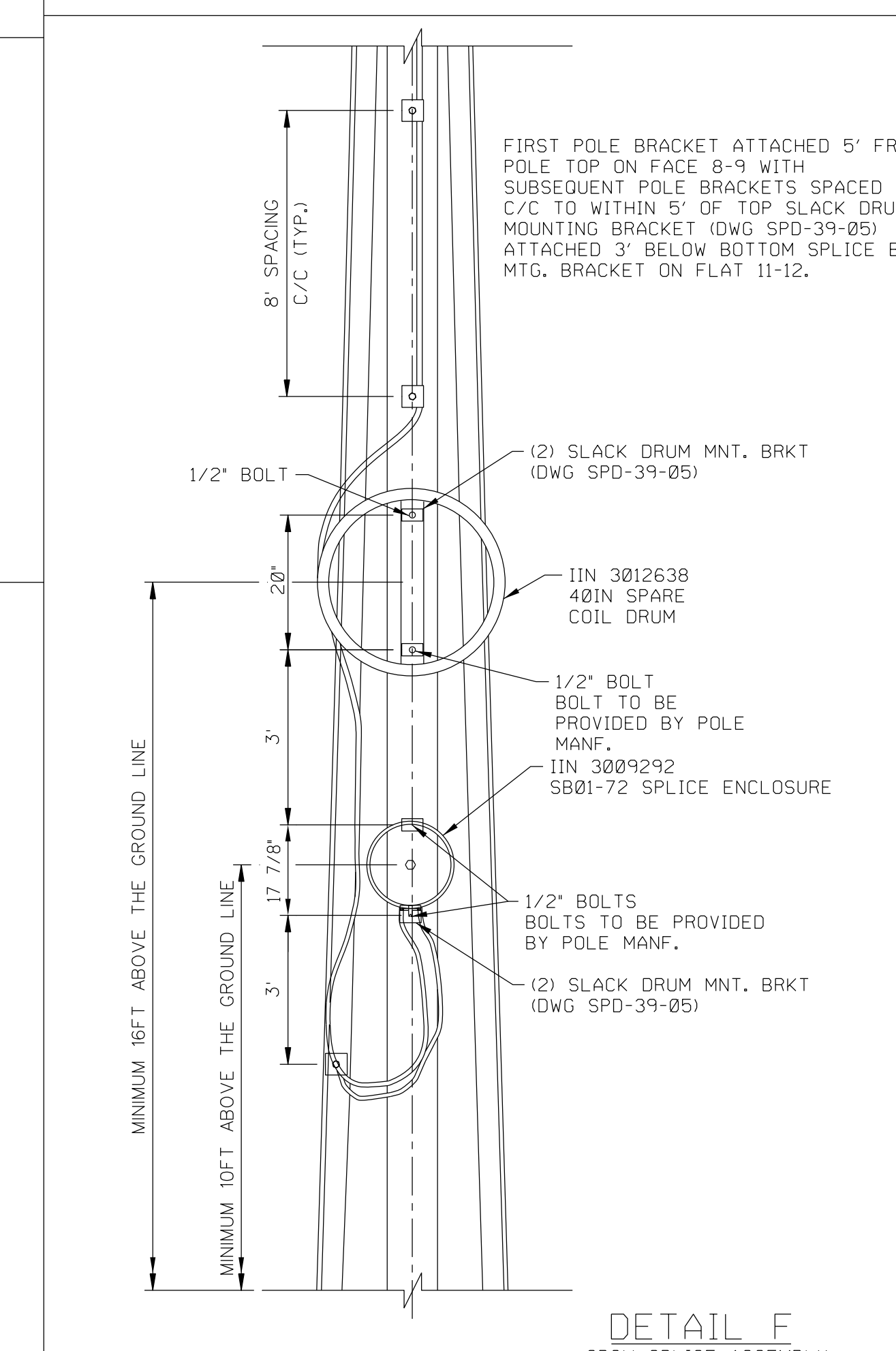
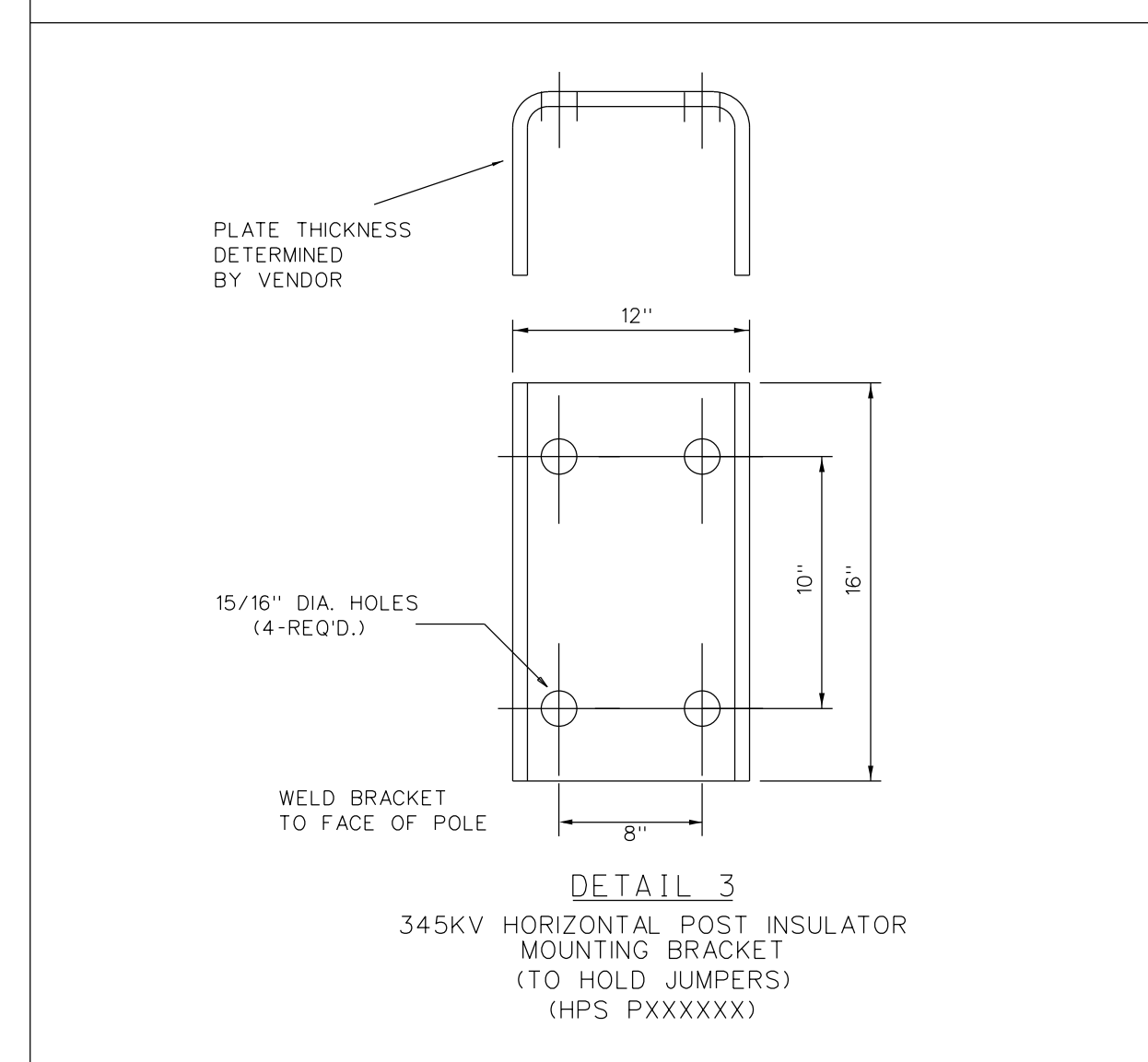
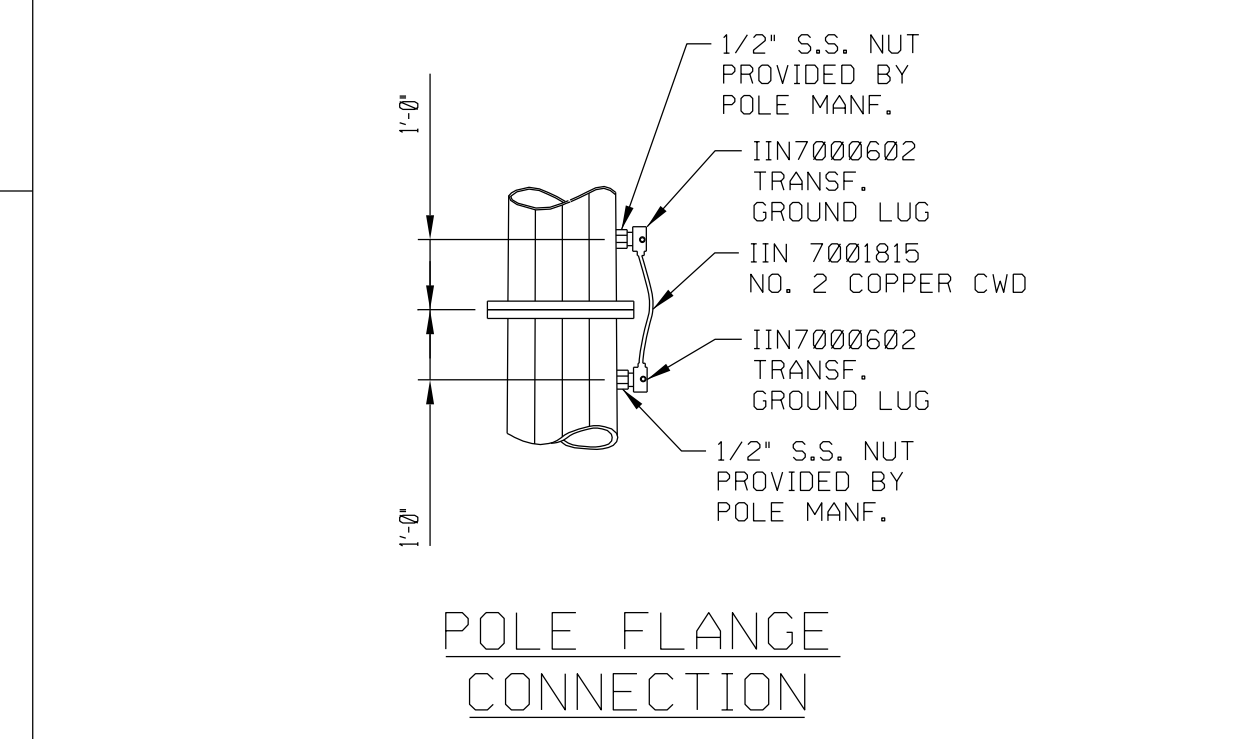

KU Kentucky Utilities Company
Lexington, Kentucky

Project: LI-167444	Drawn: NAP	Checked:	Approved:
GLENDALE SOUTH - BROWN NORTH 345KV			
STRUCTURE #16 130' SELF-SUPPORTING DEADEND STRUCTURE			
Scale: NTS	Drawing Number: STR16-P2		

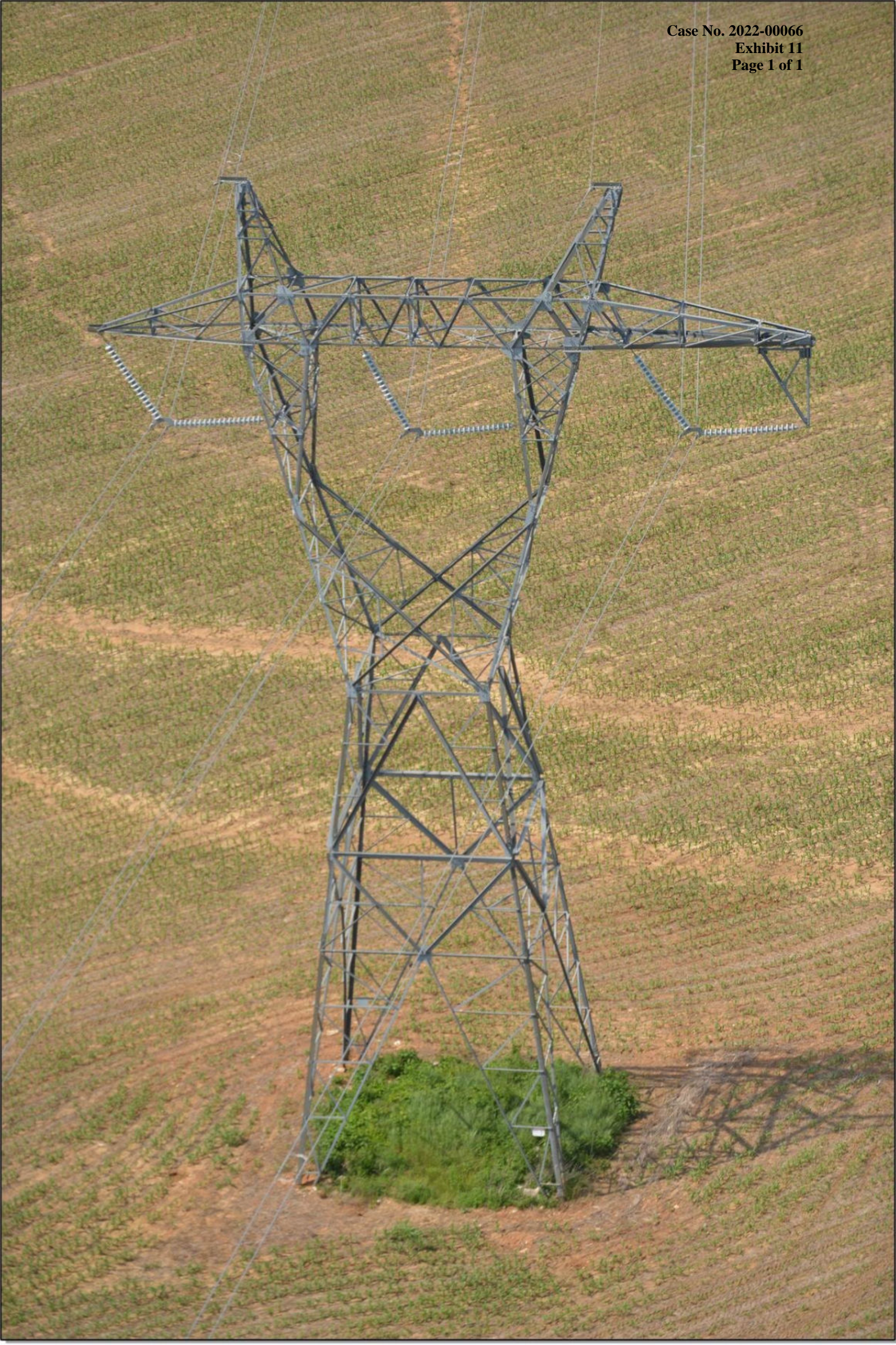







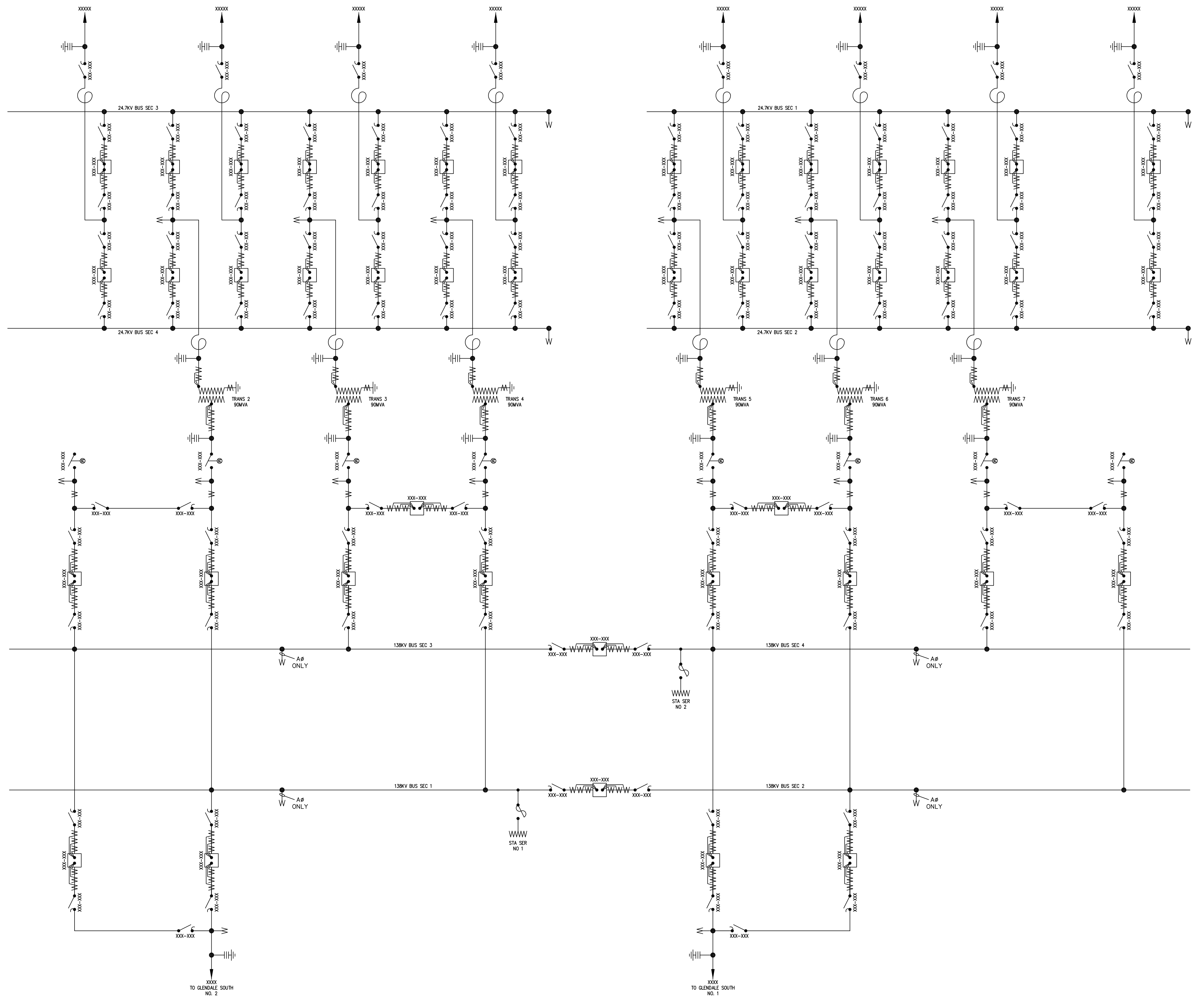
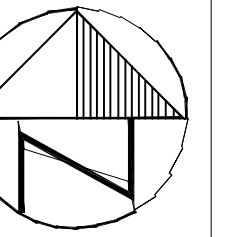

STATION LOCATION
 HOOBLE RD #
 GLENDALE, KY 42740
 57.588248, -85.886739

PRELIMINARY

FOR REVIEW ONLY
 NOT FOR CONSTRUCTION

DRAWING RELEASE RECORD

DRAWING RELEASE RECORD

REV.	DATE	PROJECT	DRAWN	APPROVED	DESCRIPTION

REV.	DATE	PROJECT	DRAWN	APPROVED	DESCRIPTION

Project:	Drawn: BV 03/04/2022	Approved:	Scale: NONE
GLENDALE INDUSTRIAL SUBSTATION 138/24.7KV SUBSTATION SWITCHING DIAGRAM			
		Drawing Number: SD-470	Revision A

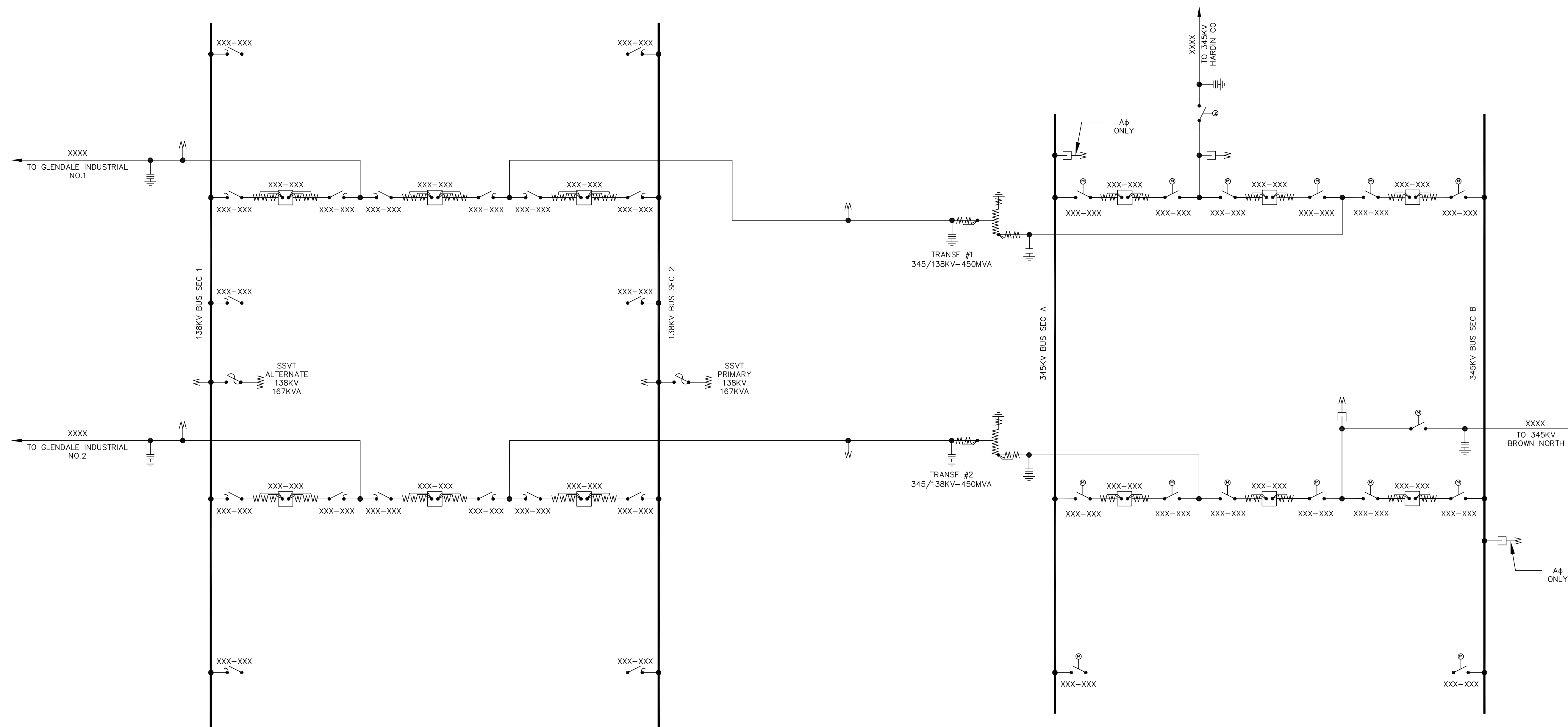
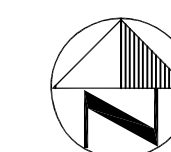

STATION LOCATION
 HODGVILLE RD W
 GLENDALE KY 42740
 37.588248, -85.886739

PRELIMINARY

FOR REVIEW ONLY
 NOT FOR CONSTRUCTION



SUBSTATION ENGINEERING AND DESIGN

GLENDALE SOUTH
345/138KV SUBSTATION
SWITCHING DIAGRAM

DRAWN: HMB-B&V
 REVISED: _____

KU-SD-251 A