

**COMMONWEALTH OF KENTUCKY
BEFORE THE PUBLIC SERVICE COMMISSION**

In the Matter of:

THE APPLICATION OF)	
CELLCO PARTNERSHIP D/B/A VERIZON WIRELESS)	
FOR ISSUANCE OF A CERTIFICATE OF PUBLIC)	CASE NO. 2022-0016
CONVENIENCE AND NECESSITY TO CONSTRUCT)	
A WIRELESS COMMUNICATIONS FACILITY)	
IN THE COMMONWEALTH OF KENTUCKY)	
IN THE COUNTY OF BALLARD)	

SITE NAME: BARLOW

* * * * *

**APPLICATION FOR
CERTIFICATE OF PUBLIC CONVENIENCE AND NECESSITY
FOR CONSTRUCTION OF A WIRELESS COMMUNICATIONS FACILITY**

Cellco Partnership, d/b/a Verizon Wireless (“Applicant”), by counsel, pursuant to (i) KRS §§278.020, 278.040, 278.650, 278.665, and other statutory authority, and the rules and regulations applicable thereto, and (ii) the Telecommunications Act of 1996, respectfully submits this Application requesting issuance of a Certificate of Public Convenience and Necessity (“CPCN”) from the Kentucky Public Service Commission (“PSC”) to construct, maintain, and operate a Wireless Communications Facility (“WCF”) to serve the customers of the Applicant with wireless communications services.

In support of this Application, Applicant respectfully provides and states the following information:

1. The complete name and address of the Applicant: Cellco Partnership, d/b/a Verizon Wireless, having a local address of 2421 Holloway Road, Louisville, KY 40299.

2. Applicant is a Delaware general partnership and a copy of the Amended Certificate of Assumed Name is on file with the Secretary of State of Commonwealth of Kentucky is included as part of **Exhibit A**.

3. Applicant proposes construction of an antenna tower for communications services, which is to be located in an area outside the jurisdiction of a planning commission, and Applicant submits this application to the PSC for a certificate of public convenience and necessity pursuant to KRS §§ 278.020(1), 278.040, 278.650, 278.665, and other statutory authority.

4. The Applicant operates on frequencies licensed by the Federal Communications Commission ("FCC") pursuant to applicable FCC requirements. A copy of the Applicant's FCC licenses to provide wireless services are attached to this Application or described as part of **Exhibit B**, and the facility will be constructed and operated in accordance with applicable FCC regulations.

5. The public convenience and necessity require the construction of the proposed WCF. The construction of the WCF will bring or improve the Applicant's services to an area currently not served or not adequately served by the Applicant by increasing coverage or capacity and thereby enhancing the public's access to innovative and competitive wireless communications services. A statement from Applicant's RF Design Engineer outlining said need is attached as **Exhibit Q** along with Propagation Maps attached as **Exhibit Qa**. The WCF is an integral link in the Applicant's network design that must be in place to provide adequate coverage to the service area.

6. To address the above-described service needs, Applicant proposes to construct a WCF at 2244 Steve Denton Road, Barlow KY 42024 (37° 06' 42.15"North latitude, 89° 02'

44.58” West longitude), on a parcel of land located entirely within the county referenced in the caption of this application. The property on which the WCF will be located is owned by Myatt Family Trust pursuant to a Deed recorded at Deed Book 93, Page 150 in the office of the County Clerk. The proposed WCF will consist of a 285-foot tall tower, with an approximately 5-foot tall lightning arrestor attached at the top, for a total height of 290-feet. The WCF will also include concrete foundations and a shelter or cabinets to accommodate the placement of the Applicant's radio electronics equipment and appurtenant equipment. The Applicant's equipment cabinet or shelter will be approved for use in the Commonwealth of Kentucky by the relevant building inspector. The WCF compound will be fenced and all access gate(s) will be secured. A description of the manner in which the proposed WCF will be constructed is attached as **Exhibit C** and **Exhibit D**.

7. A list of utilities, corporations, or persons with whom the proposed WCF is likely to compete along with a map showing the proposed location as well as the identified like facilities is attached as **Exhibit E**.

8. The site development plan and a vertical profile sketch of the WCF signed and sealed by a professional engineer registered in Kentucky depicting the tower height, as well as a proposed configuration for the antennas of the Applicant has also been included as part of **Exhibit C**.

9. Foundation design plans signed and sealed by a professional engineer registered in Kentucky and a description of the standards according to which the tower was designed are included as part of **Exhibit D**.

10. Applicant has considered the likely effects of the installation of the proposed WCF on nearby land uses and values and has concluded that there is no more suitable location

reasonably available from which adequate services can be provided, and that there are no reasonably available opportunities to co-locate Applicant's antennas on an existing structure. When suitable towers or structures exist, Applicant attempts to co-locate on existing structures such as communications towers or other structures capable of supporting Applicant's facilities; however, no other suitable or available co-location site was found to be located in the vicinity of the site.

11. A copy of the Determination of No Hazard to Air Navigation issued by the Federal Aviation Administration (“FAA”) is attached as **Exhibit F**.

12. A copy of the Kentucky Airport Zoning Commission (“KAZC”) Approval to construct the tower is attached as Exhibit G.

13. A geotechnical engineering report was performed at the WCF site by Alt & Witzig Engineering, Inc. Indianapolis, IN, dated August 30, 2018, and is attached as **Exhibit H**. The name and address of the geotechnical engineering firm and the professional engineer registered in Kentucky who prepared the report are included as part of **Exhibit H**.

14. Clear directions to the proposed WCF site from the County seat are attached as **Exhibit I**. The name and telephone number of the preparer of **Exhibit I** are included as part of this exhibit.

15. Applicant, pursuant to a written agreement, has acquired the right to use the WCF site and associated property rights. A copy of the agreement or an abbreviated agreement recorded with the County Clerk is attached as **Exhibit J**.

16. Personnel directly responsible for the design and construction of the proposed WCF are well qualified and experienced. The tower and foundation drawings for the proposed tower submitted as part of **Exhibit D** bear the signature and stamp of a professional engineer

registered in the Commonwealth of Kentucky. All tower designs meet or exceed the minimum requirements of applicable laws and regulations.

17. The Construction Manager for the proposed facility is Vince Caprino and the identity and qualifications of each person directly responsible for design and construction of the proposed tower are contained in **Exhibit R**.

18. As noted on the Survey attached as part of **Exhibit C**, the surveyor has determined that the tower site and access easement are not within any flood hazard area per Flood Hazard Boundary Map, Community Panel Number 21007C0085C, Dated July 7, 2014. Also find a letter from the surveyor regarding the Flood Data, attached as **Exhibit Ca**.

19. **Exhibit C** includes a map drawn to an appropriate scale that shows the location of the proposed tower and identifies every owner of real estate within 500 feet of the proposed tower (according to the records maintained by the County Property Valuation Administrator). Every structure and every easement within 500 feet of the proposed tower or within 200 feet of the access road including intersection with the public street system is illustrated in **Exhibit C**.

20. Applicant has notified every person who, according to the records of the County Property Valuation Administrator, owns property which is within 500 feet of the proposed tower or contiguous to the site property, by certified mail, return receipt requested, of the proposed construction. Each notified property owner has been provided with a map of the location of the proposed construction, the PSC docket number for this application, the address of the PSC, and will be informed of his or her right to request intervention. A list of the notified property owners and a copy of the form of the notice to be sent by certified mail to each landowner are attached as **Exhibit K** and **Exhibit L**, respectively.

21. Applicant has notified the applicable County Judge/Executive by certified mail, return receipt requested, of the proposed construction. This notice included the PSC docket number under which the application will be processed and informed the County Judge/Executive of his/her right to request intervention. A copy of this notice is attached as **Exhibit M**.

22. Notice signs meeting the requirements prescribed by 807 KAR 5:063, Section 1(2) that measure at least 2 feet in height and 4 feet in width and that contain all required language in letters of required height, have been posted, one in a visible location on the proposed site and one on the nearest public road. Such signs shall remain posted for at least two weeks after filing of the Application, and a copy of the posted text is attached as **Exhibit N**. A legal notice advertisement regarding the location of the proposed facility has been published in a newspaper of general circulation in the county in which the WCF is proposed to be located. A copy of the newspaper legal notice advertisement is attached as **Exhibit O**.

23. The general area where the proposed facility is to be located is undeveloped and removed a significant distance from any residential structures. The nearest residential structure is 284.38 feet from the proposed tower site.

24. The process that was used by the Applicant's radio frequency engineers in selecting the site for the proposed WCF was consistent with the general process used for selecting all other existing and proposed WCF facilities within the proposed network design area. Applicant's radio frequency engineers have conducted studies and tests in order to develop a highly efficient network that is designed to handle voice and data traffic in the service area. The engineers determined an optimum area for the placement of the proposed facility in terms of elevation and location to provide the best quality service to customers in the service area. A radio frequency design search area prepared in reference to these radio frequency studies was

considered by the Applicant when searching for sites for its antennas that would provide the coverage deemed necessary by the Applicant. A map of the area in which the tower is proposed to be located which is drawn to scale and clearly depicts the necessary search area within which the site should be located pursuant to radio frequency requirements is attached as **Exhibit P**.

25. The tower must be located at the proposed location and proposed height to provide necessary service to wireless communications users in the subject area, as set out and documented in the RF Design Engineers' Statement of Need and Propagation Maps attached as **Exhibit Q**. The proposed tower will expand and improve voice and data service for Verizon Wireless customers.

26. All Exhibits to this Application are hereby incorporated by reference as if fully set out as part of the Application.

27. All responses and requests associated with this Application may be directed to:

Russell L. Brown
Clark, Quinn, Moses, Scott & Grahn, LLP
320 North Meridian Street, Suite 1100
Indianapolis, IN 46204
Phone: (317) 637-1321
FAX: (317) 687-2344
Email: rbrown@clarkquinnlaw.com

WHEREFORE, Applicant respectfully request that the PSC accept the foregoing Application for filing, and having met the requirements of KRS §§278.020(1), 278.650, and 278.665 and all applicable rules and regulations of the PSC, grant a Certificate of Public Convenience and Necessity to construct and operate the WCF at the location set forth herein.

Respectfully submitted,

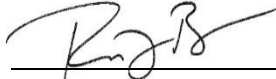

Russell L. Brown

Clark, Quinn, Moses, Scott & Grahn, LLP

320 North Meridian Street, Suite 1100

Indianapolis, IN 46204

Phone: (317) 637-1321 / FAX: (317) 687-2344

Email: rbrown@clarkquinnlaw.com

Attorney for Cellco Partnership d/b/a Verizon Wireless

LIST OF EXHIBITS

- A Applicant Entity
- B FCC License Documentation
- C Site Development Plan:
500' Vicinity Map Legal Descriptions
Flood Plain Certification Site Plan
Vertical Tower Profile
- Ca Letter from Surveyor regarding Flood Data
- D Tower and Foundation Design
- E Competing Utilities, Corporations, or Persons List
And Map of Like Facilities in Vicinity
- F FAA
- G KAZC Approval
- H Geotechnical Report
- I Directions to WCF Site
- J Copy of Real Estate Agreement
- K Notification Listing
- L Copy of Property Owner Notification
- M Copy of County Judge/Executive notice
- N Copy of Posted Notices
- O Copy of Newspaper Legal Notice Advertisement
- P Copy of Radio Frequency Design Search Area
- Q Copy of RF Design Engineer State of Need
- Qa Propagation Maps
- R List of Qualified Professionals

A

COMMONWEALTH OF KENTUCKY
TREY GRAYSON
SECRETARY OF STATE



1
Secretary of State
Received and Filed
08/27/2008 12:05:00 PM
Fee Receipt: \$20.00

CERTIFICATE OF ASSUMED NAME

This certifies that the assumed name of
Verizon Wireless

has been adopted by See Addendum

which is the "real name" of (YOU MUST CHECK ONE)

- | | |
|--|---|
| <input type="checkbox"/> a Domestic General Partnership | <input checked="" type="checkbox"/> a Foreign General Partnership |
| <input type="checkbox"/> a Domestic Registered Limited Liability Partnership | <input type="checkbox"/> a Foreign Registered Limited Liability Partnership |
| <input type="checkbox"/> a Domestic Limited Partnership | <input type="checkbox"/> a Foreign Limited Partnership |
| <input type="checkbox"/> a Domestic Business Trust | <input type="checkbox"/> a Foreign Business Trust |
| <input type="checkbox"/> a Domestic Corporation | <input type="checkbox"/> a Foreign Corporation |
| <input type="checkbox"/> a Domestic Limited Liability Company | <input type="checkbox"/> a Foreign Limited Liability Company |
| <input type="checkbox"/> a Joint Venture | |

organized and existing in the state or country of Delaware, and whose address is
One Verizon Way Masking Ridge NJ 07920

The certificate of assumed name is executed by

NYNEX PCS Inc.

[Signature]
Jose A. Schepker-Assistant Secretary
June 18, 2008

0641227.07 dcornish
 AMD
 Allison Lundergan Grimes
 Kentucky Secretary of State
 Received and Filed:
 1/22/2013 1:43 PM
 Fee Receipt: \$20.00



COMMONWEALTH OF KENTUCKY
 ELAINE N. WALKER, SECRETARY OF STATE

Division of Business Filings Business Filings PO Box 718 Frankfort, KY 40602 (502) 564-3400 www.sos.ky.gov	Amended Certificate of Assumed Name (Domestic or Foreign Business Entity) AAN
---	---

Pursuant to the provisions of KRS 365, the undersigned applies to amend the certificate of assumed name and, for that purpose, submits the following statement:

- The assumed name is Verizon Wireless
(The name must be identical to the name on record with the Secretary of State.)
- The certificate of assumed name was filed with the Secretary of State on: 6/21/2006
- The current principal office address (if any) is:
One Verizon Way Basking Ridge NJ 07920
Street Address or Post Office Box Number City State Zip
- The principal office address is hereby changed to:
Street Address or Post Office Box Number City State Zip
- This application will be effective upon filing, unless a delayed effective date and/or time is provided. The effective date or the delayed effective date cannot be prior to the date the application is filed. The date and/or time is: _____
(Delayed effective date and/or time)
- The changes in the identity of the partners are as follows: See Addendum for current partners

I declare under penalty of perjury under the laws of Kentucky that the foregoing is true and correct.
 GTE Wireless Incorporated

 Signature of Applicant	<u>Jane A. Schapker</u> Printed Name	<u>Assistant Secretary</u> Title	<u>1/21/2012</u> Date
---	---	-------------------------------------	--------------------------

Addendum

The full name of the Partnership is Celco Partnership, a Delaware general partnership composed of the following partners:

<i>General Partners of Celco Partnership</i>	<i>Address</i>
Bell Atlantic Mobile Systems LLC	One Verizon Way Basking Ridge, NJ 07920
GTE Wireless Incorporated	One Verizon Way Basking Ridge, NJ 07920
PCS Nucleus, L.P.	Denver Place South Tower 999-18 th Street, Suite 1750 Denver, CO 80202
IV PartnerCo, LLC	Denver Place South Tower 999-18 th Street, Suite 1750 Denver, CO 80202

REFERENCE COPY

This is not an official FCC license. It is a record of public information contained in the FCC's licensing database on the date that this reference copy was generated. In cases where FCC rules require the presentation, posting, or display of an FCC license, this document may not be used in place of an official FCC license.



**Federal Communications Commission
Wireless Telecommunications Bureau**

RADIO STATION AUTHORIZATION

LICENSEE: KENTUCKY RSA NO. 1 PARTNERSHIP

ATTN: REGULATORY
KENTUCKY RSA NO. 1 PARTNERSHIP
5055 NORTH POINT PKWY, NP2NE NETWORK ENGINEERING
ALPHARETTA, GA 30022

Call Sign KNKQ306	File Number
Radio Service CL - Cellular	
Market Numer CMA443	Channel Block B
Sub-Market Designator 0	

FCC Registration Number (FRN): 0001836709

Market Name Kentucky 1 - Fulton

Grant Date 08-30-2011	Effective Date 11-02-2016	Expiration Date 10-01-2021	Five Yr Build-Out Date	Print Date
---------------------------------	-------------------------------------	--------------------------------------	-------------------------------	-------------------

Site Information:

Location	Latitude	Longitude	Ground Elevation (meters)	Structure Hgt to Tip (meters)	Antenna Structure Registration No.
1	36-20-59.2 N	089-22-12.3 W	98.0		

Address: 0.68 MILE SOUTH OF LASSITER CORNER & REEL FOOT LAKE

City: LASSITER CORNER **County:** LAKE **State:** TN **Construction Deadline:**

Antenna: 1

Maximum Transmitting ERP in Watts: 135.800

Azimuth(from true north)	0	45	90	135	180	225	270	315
Antenna Height AAT (meters)	148.000	117.000	107.000	117.000	121.000	147.000	149.000	146.000
Transmitting ERP (watts)	133.300	103.500	36.500	4.500	1.500	3.900	38.800	109.600

Conditions:

Pursuant to §309(h) of the Communications Act of 1934, as amended, 47 U.S.C. §309(h), this license is subject to the following conditions: This license shall not vest in the licensee any right to operate the station nor any right in the use of the frequencies designated in the license beyond the term thereof nor in any other manner than authorized herein. Neither the license nor the right granted thereunder shall be assigned or otherwise transferred in violation of the Communications Act of 1934, as amended. See 47 U.S.C. § 310(d). This license is subject in terms to the right of use or control conferred by §706 of the Communications Act of 1934, as amended. See 47 U.S.C. §606.

Licensee Name: KENTUCKY RSA NO. 1 PARTNERSHIP

Call Sign: KNKQ306

File Number:

Print Date:

Location	Latitude	Longitude	Ground Elevation (meters)	Structure Hgt to Tip (meters)	Antenna Structure Registration No.
2	36-45-58.0 N	088-38-50.0 W	143.0	147.8	1043917

Address: 416 Jimtown Road

City: MAYFIELD County: GRAVES State: KY Construction Deadline:

Antenna: 2

Maximum Transmitting ERP in Watts:	140.820							
Azimuth(from true north)	0	45	90	135	180	225	270	315
Antenna Height AAT (meters)	124.300	120.000	100.800	92.100	88.300	103.100	108.600	100.800
Transmitting ERP (watts)	91.200	87.100	85.110	85.110	89.130	87.100	89.130	89.130

Location	Latitude	Longitude	Ground Elevation (meters)	Structure Hgt to Tip (meters)	Antenna Structure Registration No.
4	36-54-35.5 N	089-04-01.6 W	110.3	121.0	1030662

Address: (Wickliffe) 353 CR 1307

City: Bardwell County: CARLISLE State: KY Construction Deadline:

Antenna: 4

Maximum Transmitting ERP in Watts:	140.820							
Azimuth(from true north)	0	45	90	135	180	225	270	315
Antenna Height AAT (meters)	107.500	98.100	119.800	96.700	86.900	133.300	130.900	130.400
Transmitting ERP (watts)	189.230	48.640	1.690	0.930	0.930	0.930	1.810	52.120

Antenna: 5

Maximum Transmitting ERP in Watts:	140.820							
Azimuth(from true north)	0	45	90	135	180	225	270	315
Antenna Height AAT (meters)	107.500	98.100	119.800	96.700	86.900	133.300	130.900	130.400
Transmitting ERP (watts)	1.710	64.860	368.980	174.580	8.750	0.930	0.930	0.930

Antenna: 6

Maximum Transmitting ERP in Watts:	140.820							
Azimuth(from true north)	0	45	90	135	180	225	270	315
Antenna Height AAT (meters)	107.800	98.100	119.800	96.700	86.900	133.300	130.900	130.400
Transmitting ERP (watts)	0.350	0.350	1.230	35.330	112.440	35.270	1.000	0.350

Location	Latitude	Longitude	Ground Elevation (meters)	Structure Hgt to Tip (meters)	Antenna Structure Registration No.
6	36-31-12.4 N	088-50-41.5 W	144.2	122.2	1030665

Address: (Fulton) 550 Powell Road

City: Fulton County: HICKMAN State: KY Construction Deadline:

Antenna: 4

Maximum Transmitting ERP in Watts:	140.820							
Azimuth(from true north)	0	45	90	135	180	225	270	315
Antenna Height AAT (meters)	128.200	122.800	123.200	135.200	147.500	157.200	143.900	141.700
Transmitting ERP (watts)	110.570	412.100	98.560	4.220	1.510	0.920	0.920	6.530

Antenna: 5

Maximum Transmitting ERP in Watts:	140.820							
Azimuth(from true north)	0	45	90	135	180	225	270	315
Antenna Height AAT (meters)	128.200	122.800	123.200	135.200	147.500	157.200	143.900	141.700
Transmitting ERP (watts)	0.550	0.550	0.550	0.550	1.480	16.430	11.480	0.700

Licensee Name: KENTUCKY RSA NO. 1 PARTNERSHIP

Call Sign: KNKQ306

File Number:

Print Date:

Location	Latitude	Longitude	Ground Elevation (meters)	Structure Hgt to Tip (meters)	Antenna Structure Registration No.
6	36-31-12.4 N	088-50-41.5 W	144.2	122.2	1030665

Address: (Fulton) 550 Powell Road

City: Fulton County: HICKMAN State: KY Construction Deadline:

Antenna: 6

Maximum Transmitting ERP in Watts:	140.820							
Azimuth(from true north)	0	45	90	135	180	225	270	315
Antenna Height AAT (meters)	128.200	122.800	123.200	135.200	147.500	157.200	143.900	141.700
Transmitting ERP (watts)	135.480	5.650	2.230	0.920	1.320	5.450	78.640	402.820

Location	Latitude	Longitude	Ground Elevation (meters)	Structure Hgt to Tip (meters)	Antenna Structure Registration No.
7	36-38-26.2 N	088-16-00.1 W	165.8	90.8	1030663

Address: (Murray) 1431 Van Cleave Road

City: Murray County: CALLOWAY State: KY Construction Deadline:

Antenna: 4

Maximum Transmitting ERP in Watts:	140.820							
Azimuth(from true north)	0	45	90	135	180	225	270	315
Antenna Height AAT (meters)	106.900	107.100	115.000	106.900	87.400	91.300	86.200	97.500
Transmitting ERP (watts)	124.240	6.420	0.560	0.560	0.560	0.830	39.630	251.940

Antenna: 5

Maximum Transmitting ERP in Watts:	140.820							
Azimuth(from true north)	0	45	90	135	180	225	270	315
Antenna Height AAT (meters)	106.900	107.100	115.000	106.900	87.400	91.300	86.200	97.500
Transmitting ERP (watts)	3.450	96.460	263.070	57.230	1.700	0.560	0.560	0.560

Antenna: 6

Maximum Transmitting ERP in Watts:	140.820							
Azimuth(from true north)	0	45	90	135	180	225	270	315
Antenna Height AAT (meters)	106.900	107.100	115.000	106.900	87.400	91.300	86.200	97.500
Transmitting ERP (watts)	0.370	0.370	0.370	12.730	121.110	104.340	9.310	0.370

Location	Latitude	Longitude	Ground Elevation (meters)	Structure Hgt to Tip (meters)	Antenna Structure Registration No.
8	37-03-51.4 N	088-57-23.6 W	116.4	92.4	1030664

Address: (La Center) 220 RICHARDSON LN

City: LA CENTER County: BALLARD State: KY Construction Deadline:

Antenna: 2

Maximum Transmitting ERP in Watts:	140.820							
Azimuth(from true north)	0	45	90	135	180	225	270	315
Antenna Height AAT (meters)	85.600	78.400	71.900	66.000	65.300	67.000	87.700	96.100
Transmitting ERP (watts)	2.110	71.430	167.460	63.670	0.330	0.640	0.330	0.330

Antenna: 3

Maximum Transmitting ERP in Watts:	140.820							
Azimuth(from true north)	0	45	90	135	180	225	270	315
Antenna Height AAT (meters)	85.600	78.400	71.900	66.000	65.300	67.000	87.700	96.100
Transmitting ERP (watts)	1.230	1.000	1.380	23.440	338.840	457.090	66.070	2.240

Licensee Name: KENTUCKY RSA NO. 1 PARTNERSHIP

Call Sign: KNKQ306

File Number:

Print Date:

Location	Latitude	Longitude	Ground Elevation (meters)	Structure Hgt to Tip (meters)	Antenna Structure Registration No.
8	37-03-51.4 N	088-57-23.6 W	116.4	92.4	1030664

Address: (La Center) 220 RICHARDSON LN

City: LA CENTER County: BALLARD State: KY Construction Deadline:

Antenna: 4

Maximum Transmitting ERP in Watts:	140.820							
Azimuth(from true north)	0	45	90	135	180	225	270	315
Antenna Height AAT (meters)	85.600	78.400	71.900	66.000	65.300	67.000	87.700	96.100
Transmitting ERP (watts)	165.960	6.610	0.910	0.500	0.500	0.890	45.710	223.870

Location	Latitude	Longitude	Ground Elevation (meters)	Structure Hgt to Tip (meters)	Antenna Structure Registration No.
10	36-44-07.9 N	088-58-29.2 W	131.9	92.9	1030723

Address: 3975 State Route 2206

City: CLINTON County: HICKMAN State: KY Construction Deadline:

Antenna: 2

Maximum Transmitting ERP in Watts:	140.820							
Azimuth(from true north)	0	45	90	135	180	225	270	315
Antenna Height AAT (meters)	100.500	101.900	98.900	84.700	107.900	118.900	119.900	100.400
Transmitting ERP (watts)	96.610	96.610	96.610	96.610	96.610	96.610	96.610	96.610

Location	Latitude	Longitude	Ground Elevation (meters)	Structure Hgt to Tip (meters)	Antenna Structure Registration No.
11	37-02-00.0 N	088-22-10.0 W	105.5	106.7	1040303

Address: (Calvert City) 641 Jary Johnson Rd.

City: Calvert City County: MARSHALL State: KY Construction Deadline:

Antenna: 2

Maximum Transmitting ERP in Watts:	140.820							
Azimuth(from true north)	0	45	90	135	180	225	270	315
Antenna Height AAT (meters)	78.900	77.600	88.100	83.000	68.600	85.300	97.900	93.100
Transmitting ERP (watts)	23.380	330.300	378.360	36.130	0.970	0.970	0.970	0.970

Antenna: 3

Maximum Transmitting ERP in Watts:	140.820							
Azimuth(from true north)	0	45	90	135	180	225	270	315
Antenna Height AAT (meters)	78.900	77.600	88.100	83.000	68.600	85.300	97.900	93.100
Transmitting ERP (watts)	0.970	0.970	0.970	14.730	240.930	357.480	49.940	1.230

Antenna: 4

Maximum Transmitting ERP in Watts:	140.820							
Azimuth(from true north)	0	45	90	135	180	225	270	315
Antenna Height AAT (meters)	78.900	77.600	88.100	83.000	68.600	85.300	97.900	93.100
Transmitting ERP (watts)	63.740	2.060	0.660	0.660	0.660	4.020	107.530	274.970

Licensee Name: KENTUCKY RSA NO. 1 PARTNERSHIP

Call Sign: KKNQ306

File Number:

Print Date:

Location	Latitude	Longitude	Ground Elevation (meters)	Structure Hgt to Tip (meters)	Antenna Structure Registration No.
12	36-34-49.2 N	088-31-45.2 W	155.5	91.4	1202399

Address: 12201 SR 97

City: TriCity County: GRAVES State: KY Construction Deadline:

Antenna: 2

Maximum Transmitting ERP in Watts:	140.820							
Azimuth(from true north)	0	45	90	135	180	225	270	315
Antenna Height AAT (meters)	75.100	73.400	74.100	70.100	102.600	100.900	74.700	81.300
Transmitting ERP (watts)	0.280	4.680	67.610	91.200	13.180	0.450	0.250	0.200

Antenna: 3

Maximum Transmitting ERP in Watts:	140.820							
Azimuth(from true north)	0	45	90	135	180	225	270	315
Antenna Height AAT (meters)	75.100	73.400	74.100	70.100	102.600	100.900	74.700	81.300
Transmitting ERP (watts)	0.360	0.200	0.200	0.350	18.200	89.130	66.070	2.630

Antenna: 4

Maximum Transmitting ERP in Watts:	140.820							
Azimuth(from true north)	0	45	90	135	180	225	270	315
Antenna Height AAT (meters)	75.100	73.400	74.100	70.100	102.600	100.900	74.700	81.300
Transmitting ERP (watts)	100.000	38.020	0.200	0.380	0.200	0.200	1.260	42.660

Location	Latitude	Longitude	Ground Elevation (meters)	Structure Hgt to Tip (meters)	Antenna Structure Registration No.
14	37-05-47.2 N	088-42-35.2 W	104.2	63.4	1200593

Address: (Paducah West) 4415 Merredith Rd.

City: Paducah County: MCCRACKEN State: KY Construction Deadline: 07-08-2014

Antenna: 4

Maximum Transmitting ERP in Watts:	140.820							
Azimuth(from true north)	0	45	90	135	180	225	270	315
Antenna Height AAT (meters)	59.900	55.900	65.200	50.700	38.200	34.700	42.800	64.600
Transmitting ERP (watts)	24.580	50.820	50.310	19.100	0.840	0.330	0.330	1.370

Antenna: 5

Maximum Transmitting ERP in Watts:	140.820							
Azimuth(from true north)	0	45	90	135	180	225	270	315
Antenna Height AAT (meters)	59.900	55.900	65.200	50.700	38.200	34.700	42.800	64.600
Transmitting ERP (watts)	0.440	0.440	12.210	76.570	112.800	57.980	5.460	0.440

Antenna: 6

Maximum Transmitting ERP in Watts:	140.820							
Azimuth(from true north)	0	45	90	135	180	225	270	315
Antenna Height AAT (meters)	59.900	55.900	65.200	50.700	38.200	34.700	42.800	64.600
Transmitting ERP (watts)	20.830	0.780	0.440	0.440	2.790	42.940	108.040	89.900

Licensee Name: KENTUCKY RSA NO. 1 PARTNERSHIP

Call Sign: KNKQ306

File Number:

Print Date:

Location	Latitude	Longitude	Ground Elevation (meters)	Structure Hgt to Tip (meters)	Antenna Structure Registration No.
15	36-46-54.2 N	088-03-28.1 W	199.0	126.5	1205551

Address: 14664 Canton Road

City: Golden Pond County: TRIGG State: KY Construction Deadline: 05-19-2006

Antenna: 2

Maximum Transmitting ERP in Watts:	140.820							
Azimuth(from true north)	0	45	90	135	180	225	270	315
Antenna Height AAT (meters)	165.000	178.000	160.400	174.500	170.600	167.000	177.000	183.900
Transmitting ERP (watts)	96.610	96.610	96.610	96.610	96.610	96.610	96.610	96.610

Location	Latitude	Longitude	Ground Elevation (meters)	Structure Hgt to Tip (meters)	Antenna Structure Registration No.
16	36-34-03.0 N	089-10-30.9 W	109.4	91.4	1282534

Address: (Hickman site) Holley Street

City: Hickman County: FULTON State: KY Construction Deadline: 05-28-2014

Antenna: 1

Maximum Transmitting ERP in Watts:	140.820							
Azimuth(from true north)	0	45	90	135	180	225	270	315
Antenna Height AAT (meters)	105.500	102.800	96.700	89.300	75.700	68.400	107.900	107.300
Transmitting ERP (watts)	141.700	118.910	1.140	0.580	0.580	0.580	0.580	4.050

Antenna: 2

Maximum Transmitting ERP in Watts:	140.820							
Azimuth(from true north)	0	45	90	135	180	225	270	315
Antenna Height AAT (meters)	105.500	102.800	96.700	89.300	75.700	68.400	107.900	107.300
Transmitting ERP (watts)	0.580	4.050	141.730	118.910	1.140	0.580	0.580	0.580

Antenna: 3

Maximum Transmitting ERP in Watts:	140.820							
Azimuth(from true north)	0	45	90	135	180	225	270	315
Antenna Height AAT (meters)	105.500	102.800	96.700	89.300	75.700	68.400	107.900	107.300
Transmitting ERP (watts)	0.460	0.460	0.460	0.460	0.460	7.710	45.610	24.600

Location	Latitude	Longitude	Ground Elevation (meters)	Structure Hgt to Tip (meters)	Antenna Structure Registration No.
17	37-10-55.4 N	088-56-43.7 W	102.7	99.1	1252613

Address: (Monkey's Eyebrow) 4625 Odgen Colvin Circle

City: Kevil County: BALLARD State: KY Construction Deadline: 10-24-2014

Antenna: 1

Maximum Transmitting ERP in Watts:	140.820							
Azimuth(from true north)	0	45	90	135	180	225	270	315
Antenna Height AAT (meters)	85.900	83.500	90.600	69.600	74.300	84.600	86.500	83.200
Transmitting ERP (watts)	7.080	125.890	478.630	112.200	4.570	1.580	1.000	1.000

Antenna: 2

Maximum Transmitting ERP in Watts:	140.820							
Azimuth(from true north)	0	45	90	135	180	225	270	315
Antenna Height AAT (meters)	85.900	83.500	90.600	69.600	74.300	84.600	86.500	83.200
Transmitting ERP (watts)	1.000	1.410	12.020	213.800	446.680	64.570	2.820	1.000

Licensee Name: KENTUCKY RSA NO. 1 PARTNERSHIP

Call Sign: KNKQ306

File Number:

Print Date:

Location	Latitude	Longitude	Ground Elevation (meters)	Structure Hgt to Tip (meters)	Antenna Structure Registration No.
17	37-10-55.4 N	088-56-43.7 W	102.7	99.1	1252613

Address: (Monkey's Eyebrow) 4625 Odgen Colvin Circle

City: Kevil County: BALLARD State: KY Construction Deadline: 10-24-2014

Antenna: 4

Maximum Transmitting ERP in Watts: 140.820

Azimuth (from true north)	0	45	90	135	180	225	270	315
Antenna Height AAT (meters)	85.900	83.500	90.600	69.600	74.300	84.600	86.500	83.200
Transmitting ERP (watts)	2.000	2.000	2.000	2.000	2.000	398.110	549.540	4.900

Control Points:

Control Pt. No. 3

Address: 500 W. Dove Rd.

City: Southlake County: TARRANT State: TX Telephone Number: (800)264-6620

Waivers/Conditions:

License renewal granted on a conditional basis, subject to the outcome of FCC proceeding WT Docket No. 10-112 (see FCC 10-86, paras. 113 and 126).

EV BARLOW

2557 STEVE DENTON ROAD
 BARLOW, KY 42024
 BALLARD COUNTY
 TENANT: KENTUCKY RSA NO.1 PARTNERSHIP
 d/b/a VERIZON WIRELESS
 "EV BARLOW"

GPD GROUP, INC.
 520 South Main Street, Suite 2531
 Akron, OH 44311
 330.572.2100 Fax: 330.572.2102

KENTUCKY RSA No.1 PARTNERSHIP
 d/b/a VERIZON WIRELESS

 250 E. 96th STREET
 INDIANAPOLIS, IN 46240

KENTUCKY RSA No. 1 PARTNERSHIP
 d/b/a VERIZON WIRELESS

 250 E. 96th STREET
 INDIANAPOLIS, IN 46240

**PROPOSED 280' SELF SUPPORT TOWER
 w/5' LIGHTNING ROD
 TOTAL TOWER HEIGHT 285'**

FROM EVANSVILLE MTSO: 800 RUSSELL ROAD, CHANDLER, IN 47610: HEAD WEST RUSSELL ROAD (.2 MI), TURN RIGHT (NORTH) AT THE 1ST CROSS STREET TO STAY ON RUSSELL ROAD (.3 MI), TURN LEFT (EAST) ONTO GARDNER ROAD (1.6 MI), TURN LEFT (SOUTH) ONTO IN-62 (4.2 MI), TURN RIGHT ONTO THE I-164 S RAMP (.3 MI), MERGE ONTO I-69 S (8.1 MI), TAKE EXIT 0 TO MERGE ONTO US-41 S, TOWARD HENDERSON KY (1 MI), MERGE ONTO US-41 S (6.1 MI), KEEP LEFT TO STAY ON US-41 S (2.4 MI), KEEP LEFT TO CONTINUE ON PENNYRILE PKWY, FOLLOW SIGNS FOR OWENSBORO (1.1 MI), CONTINUE ONTO I-69 / PENNYRILE PKWY (42.6 MI), KEEP RIGHT AT THE FORK TO STAY ON I-69, FOLLOW SIGNS FOR PADUCAH (38.4 MI), TAKE EXIT 68B FOR I-24 W, TOWARD PADUCAH (.3 MI), MERGE ONTO I-24 W/I-69 S (15.9 MI), KEEP RIGHT TO CONTINUE ON I-24 W (20.9 MI), TAKE EXIT 4 FOR US-60, TOWARD I-24 / WICKLIFFE / PADUCAH (.2 MI), TURN LEFT ONTO US-60 W / HINKLEVILLE ROAD (15 MI), TURN RIGHT ONTO KY-310 N (6.5 MI), TURN LEFT ONTO KY-1105 S (2.2 MI), TURN RIGHT (WEST) ONTO SALLIE CRICE ROAD (.1 MI), SITE WILL BE ON LEFT (SOUTH) SIDE OF ROAD.

FROM BALLARD COUNTY SEAT: 132 4TH STREET, WICKLIFFE, KY 42087: HEAD NORTH ON 4TH STREET, TOWARD OHIO ST (.4 MI), 4TH STREET BECOMES LEE STREET (.1 MI), CONTINUE ONTO US-60 E / N 6TH ST (6.1 MI), TURN RIGHT ONTO BROADWAY ST (.2 MI), TURN LEFT AT THE 2ND CROSS STREET ONTO N 6TH ST (.2 MI), CONTINUE ONTO KY 1105 / OSCAR RD (4.3 MI), TURN LEFT ONTO SALLIE CRICE RD (.1 MI), SITE WILL BE ON LEFT SIDE OF ROAD.

<p>VERIZON WIRELESS SITE</p> <p>EV BARLOW PROJECT#: 20161506655 MARKET ID: LOCATION CODE: 433012</p> <p>SITE ADDRESS</p> <p>2557 STEVE DENTON ROAD, BARLOW, KY 42024 E911 ADDRESS: TBD</p> <p>TOWER OWNER</p> <p>VERIZON WIRELESS 2421 HOLLOWAY ROAD LOUISVILLE, KY 40299 CONTACT: AMY HARPER MOBILE: 502-552-0330 E-MAIL: amy.harper@verizonwireless.com</p> <p>PROPERTY OWNER</p> <p>MYATT FAMILY TRUST 2244 STEVE DENTON ROAD, BARLOW, KY 42024 CONTACT: JIMMIE H. MYATT PHONE: 270-334-3616 E-MAIL: TBD</p>	<p>POLICE</p> <p>BALLARD COUNTY SHERIFF 437 OHIO ST WICKLIFFE, KY 42087 PHONE: 270-335-3561</p> <p>FIRE</p> <p>BARLOW TWP FIRE DEPARTMENT 347 LAKE DR BARLOW, KY 42024 PHONE: 270-334-3641</p> <p>GENERAL INFORMATION</p> <p>LATITUDE -37° 06' 42.15" N LONGITUDE -89° 02' 44.58" W 1983 (NAD83) ELEVATION -363.85' AMSL 1988 (NAVD88)</p> <p>VERIZON WIRELESS EASEMENT</p> <p>100'-0" x 100'-0" (10,000 SF)</p> <p>VERIZON WIRELESS LEASE AREA</p> <p>12'-0" x 30'-0" (360 SF)</p> <p>PROJECT TOTAL DISTURBED AREA</p> <p>COMPOUND: (10,000 SF) = (0.23 ACRE) ACCESS DRIVE: (3645 SF) = (0.08 ACRE) GROSS AREA: (13645 SF) = (0.31 ACRE)</p>
--	---

PROJECT SUMMARY

<p>VERIZON WIRELESS SCOPE:</p> <ul style="list-style-type: none"> INSTALL A NEW 280' SELF-SUPPORT TOWER w/ 5' LIGHTNING ROD (TOTAL 285') INSTALL A NEW TOWER FOUNDATION SYSTEM INSTALL A NEW 98'x98' FENCED GRAVEL COMPOUND INSTALL A NEW ELECTRICAL SERVICE RUN TO SITE H-FRAME INSTALL A NEW GRAVEL ACCESS DRIVE NO WATER OR SEWAGE SERVICES RUN TO SITE INSTALL NEW TOWER & SITE GROUNDING SYSTEM INSTALL NEW VZW SUBSURFACE GROUNDING SYSTEM INSTALL A NEW 11'-6"x19'-6" CONCRETE EQUIPMENT/GENERATOR PAD INSTALL ELECTRICAL SERVICE CONDUIT WITH PULL TAPES FROM ILC ENCLOSURE STUB-UP WITHIN VZW EQUIPMENT PAD TO UTILITY H-FRAME INSTALL NEW CONDUITS WITH PULL TAPES FROM VZW ILC ENCLOSURE STUB-UPS TO EQUIPMENT ENCLOSURE STUB-UPS WITHIN VZW EQUIPMENT PAD INSTALL NEW CONDUITS WITH PULL TAPES FROM VZW ILC & EQUIPMENT ENCLOSURES STUB-UP TO GENERATOR LOCATION WITHIN VZW EQUIPMENT PAD INSTALL NEW CONDUITS WITH PULL TAPES FROM RF CABINET TO OVP H-FRAME LIT FIBER LOCATION INSTALL (1) NEW "VERIZON WIRELESS ONLY" FIBER OPTIC CONDUIT WITH PULL TAPE AND TRACER WIRE FROM VZW EQUIPMENT TO NEW "VERIZON WIRELESS ONLY" HAND HOLE OUTSIDE COMPOUND THEN TO NEW "VERIZON WIRELESS ONLY" 38"ØØØ HAND HOLE AT R.O.W. INSTALL (1) NEW "VERIZON WIRELESS ONLY" FIBER OPTIC CONDUIT WITH PULL TAPE FROM NEW "VERIZON WIRELESS ONLY" HAND HOLE AND STUB UP AT FUTURE FIBER PEDESTAL LOCATION INSTALL A NEW 11'-6"x14'-9" PREFABRICATED CANOPY ON EXISTING CONCRETE PAD FOUNDATION INSTALL VZW ICE BRIDGE AND FOUNDATIONS INSTALL VZW ANTENNA MOUNTING SUPPORT STRUCTURE ON TOWER INSTALL VZW ANTENNAS, LINES, COAX, GPS ANTENNA AND RADIO EQUIPMENT INSTALL EXISTING SUBSURFACE GROUND LEADS TO VZW EQUIPMENT & FACILITIES INSTALL VZW ELECTRIC SERVICE CONDUCTORS FROM UTILITY H-FRAME TO VZW ILC ENCLOSURE INSTALL VZW GENERATOR CIRCUITS FROM VZW ILC & EQUIPMENT ENCLOSURES TO VZW GENERATOR INSTALL CIRCUITS FROM VZW ILC TO VZW EQUIPMENT ENCLOSURES INSTALL NEW OUTDOOR OVP AND CABLING H-FRAME SUPPORT INSTALL (2) 1-1/4" & (1) 1" INNERDUCTS WITH PULL TAPES AND TRACER WIRE WITHIN OWNER INSTALLED "VERIZON WIRELESS ONLY" FIBER OPTIC CONDUITS INSTALL TOWER LIGHTING SYSTEM

PROJECT DESCRIPTION

<p>ALL WORK AND MATERIALS SHALL BE PERFORMED AND INSTALLED IN ACCORDANCE WITH THE CURRENT EDITIONS OF THE FOLLOWING CODES AS ADOPTED BY THE LOCAL GOVERNING AUTHORITIES. NOTHING IN THESE PLANS IS TO BE CONSTRUCTED TO PERMIT WORK NOT CONFORMING TO THESE CODES.</p> <p>BUILDING CODE 2013 KENTUCKY BUILDING CODE (KBC 2012) STRUCTURAL CODE TIA/EIA-222 - REVISION G (INCLUDES ADDENDUM #2) MECHANICAL CODE 2012 INTERNATIONAL MECHANICAL CODE (IMC 2012) PLUMBING CODE KENTUCKY STATE PLUMBING CODE (815 KAR CHAP. 20) ELECTRICAL CODE 2014 NATIONAL ELECTRICAL CODE (NEC) - NFPA 70 FIRE/LIFE SAFETY CODE 2012 INTERNATIONAL FIRE CODE (2012 IFC) ENERGY CODE 2012 INTERNATIONAL ENERGY CODE (COMMERCIAL) GAS CODE 2009 NATIONAL FUEL GAS CODE (NFPA 54)</p> <p>ACCESSIBILITY REQUIREMENTS: FACILITY IS UNMANNED AND NOT FOR HUMAN HABITATION. HANDICAPPED ACCESS REQUIREMENTS ARE NOT REQUIRED IN ACCORDANCE WITH THE 2009 IBC BUILDING CODE.</p>
--

APPLICABLE CODES

<p>SURVEYOR</p> <p>BENCHMARK SERVICES, INC. 318 NORTH MAIN STREET P.O. BOX 5 HUNTINGBURG, IN 47542 PHONE: 812-683-3049 FAX: 812-683-2040</p> <p>ELECTRICAL</p> <p>JACKSON PURCHASE ENERGY ADDRESS: 2900 IRVIN COBB ROAD PADUCAH, KY 42002 CONTACT: TOM DILLWORTH PHONE: 270-556-0112 EMAIL: tom.dillworth@JPEnergy.com</p>	<p>ENGINEER</p> <p>GPD GROUP, INC. 520 SOUTH MAIN STREET, SUITE 2531 AKRON, OH 44311 CONTACT: TRACI PREBLE, 317-299-2996</p>
---	---

CONSULTANT TEAM

SHEET NUMBER	DESCRIPTION
T-1	PROJECT INFORMATION, SITE MAPS, SHEET INDEX
R-1	SURVEY PLAN
R-1	REVISION LOG
TOWER ELEVATION	
TE-1	TOWER ELEVATION
CIVIL	
C-0	ENVIRONMENTAL EVALUATION "NOTICE TO CONTRACTOR" (REFERENCE ONLY)
C-1	OVERALL SITE PLAN w/AERIAL OVERLAY
C-1A	OVERALL SITE PLAN w/PAD DISTANCE TO PROPERTY LINES
C-1B	TOWER DISTANCE TO PROPERTY LINES AND RESIDENTIAL STRUCTURE
C-2	GRADING AND E&S CONTROL PLAN
C-3	DETAILED SITE PLAN
C-4	DIMENSIONED SITE PLAN
C-5	DETAILED EQUIPMENT PAD PLAN
C-6	GENERAL SITE CONSTRUCTION NOTES
C-7	BEST MANAGEMENT PRACTICES & EROSION CONTROL DETAILS AND NOTES
SITE DETAILS	
D-1	FENCE DETAILS AND NOTES
D-2	SITE DETAILS
D-3	EQUIPMENT PAD & CANOPY ELEVATIONS (REFERENCE ONLY)
D-4	SITE FENCE SIGNAGE (REFERENCE ONLY)
STRUCTURAL	
S-1	FOUNDATION PLAN AND STRUCTURAL NOTES
S-2	FOUNDATION DETAILS
S-3	FOUNDATION CONDUIT PENETRATION PLAN
S-4	ICE BRIDGE DETAILS
ELECTRICAL	
E-1	SITE UTILITY PLAN
E-2	EQUIPMENT PAD UTILITY PLAN & EQUIPMENT PAD TRENCH SECTIONS
E-3	PANEL SCHEDULE, ONE LINE DIAGRAM, ELECTRICAL NOTES AND DETAILS
E-4	ELECTRICAL DETAILS
E-5	OVP & INTEGRATED LOAD CENTER H-FRAME ELEVATIONS AND DETAILS
E-6	EQUIPMENT CABINET ELEVATIONS
E-7	EQUIPMENT PAD LIGHTING PLAN
GROUNDING	
G-1	GROUNDING SITE PLAN
G-2	GROUNDING NOTES
G-3	GROUNDING DETAILS
G-4	GROUNDING DETAILS
G-5	GROUNDING DETAILS
REFERENCE DRAWINGS	
RF-1	ANTENNA PLAN AND DETAILS (REFERENCE ONLY)
TOWER (BY OTHERS)	
TW-1	TOWER DETAILS (REFERENCE ONLY)



VICINITY MAP



LOCATION MAP



AERIAL

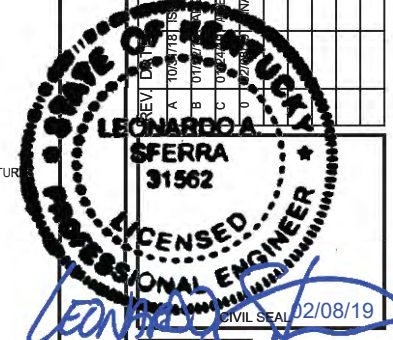

EV BARLOW
 2557 STEVE DENTON ROAD
 BARLOW, KY 42024

TITLE SHEET

ISSUED FOR:	
REVIEW	---
PERMIT	---
CONSTRUCTION	---
RECORD	---

PROJECT MANAGER	DESIGNER
TTP	DTC

JOB NO.
2017770.39

T-1

GOBBLES KNOB HUNTING CLUB, LLC
SALLIE CIRCLE ROAD
2224 DENTON ROAD
BARLOW, KY 42024
MAP NO. 24-15
DEED BOOK 112, PAGE 348

COMMONWEALTH OF KENTUCKY
DEPT OF FISH & WILDLIFE
OSCAR ROAD
HIGHWAY 1105
LA CENTER, KY 42056
MAP NO. 24-16
DEED BOOK NA, PAGE NA

SURVEYOR NOTE:
THE OWNER INFORMATION LISTED ON THIS ADJOINER DRAWING WAS OBTAINED FROM THE RECORDS FROM THE BALLARD COUNTY PVA WEBSITE AS OF 12:00 P.M. JANUARY 24, 2022. IF THIS INFORMATION IS TO BE USED FOR LEGAL PURPOSES SUCH AS A LEGAL NOTICE, THE INFORMATION SHOULD BE VERIFIED BY THE PERSON SENDING SAID NOTICE. BENCHMARK SERVICES, INC. ASSUMES NO LIABILITY FOR CHANGES IN INFORMATION AFTER THE LISTED DATE AND TIME.

ADDITIONALLY, ALL BUILDINGS AND STRUCTURES SHOWN HEREON WERE IDENTIFIED FROM GOOGLE EARTH IMAGES. IF SAID STRUCTURES ARE REQUIRED TO BE LABELED FURTHER OR DIMENSIONED A VISIT TO THE SITE WILL BE REQUIRED.

MYATT FAMILY TRUST
2224 STEVE DENTON ROAD
BARLOW, KY 42024
MAP NO. 24-29
DEED BOOK 112, PAGE 246
Location Address
6764 SALLIE CRICE ROAD

TALL PAULS HUNTING CLUB, LLC
197 ANTIOCH CHURCH ROAD
LA CENTER, KY 42056
MAP NO. 24-29-01
DEED BOOK 81, PAGE 60

CHARLES MYATT & DEE ANN MYATT, TRUSTEES
MYATT FAMILY TRUST
2224 STEVE DENTON ROAD
BARLOW, KY 42024
MAP NO. 24-30
DEED BOOK 112, PAGE 227

DAVID L. JONES
2925 STEVE DENTON ROAD
BARLOW, KY 42024
MAP NO. 24-30-01
DEED BOOK 93, PAGE 150

RHONDA RICE & COY SIMMONS
11930 WALLACE RD
KEVIL, KY 42053
MAP NO. 24-37
DEED BOOK 86, PAGE 364
Location Address
4355 OSCAR ROAD

MYATT FAMILY TRUST
2224 STEVE DENTON ROAD
BARLOW, KY 42024
MAP NO. 24-32
DEED BOOK 112, PAGE 222

MYATT POULTRY, LLC
2224 STEVE DENTON ROAD
BARLOW, KY 42024
MAP NO. 24-30-02
DEED BOOK 112, PAGE 344
Location Address
2059 STEVE DENTON ROAD

JOHN K. MOSS, ETAL
47406 JUNIPER
MACOMB, MI 48044
MAP NO. 24-36
RECORD 25, PAGE 49625
Location Address
STEVE DENTON ROAD

TALL PAULS HUNTING CLUB, LLC
197 ANTIOCH CHURCH ROAD
LA CENTER, KY 42056
MAP NO. 14-07
DEED BOOK 81, PAGE 60

MYATT FAMILY TRUST
2224 STEVE DENTON ROAD
BARLOW, KY 42024
MAP NO. 24-33
DEED BOOK 112, PAGE 234

JAMES WESLEY III ROLLINGS
CAROLYN ROLLINGS
2742 OSCAR ROAD
BARLOW, KY 42024
MAP NO. 24-24
RECORD 9, PAGE 14645

CHARLES & DEENA MYATT
CHAD & Alysia MYATT
2224 STEVE DENTON ROAD
BARLOW KY 42024
MAP NO. 24-31
DEED BOOK 114, PAGE 422
Location Address
2557 STEVE DENTON ROAD

LAND SURVEYOR'S CERTIFICATE

I HEREBY CERTIFY THAT THIS PLAT AND SURVEY WERE MADE UNDER MY SUPERVISION AND THAT THE ANGULAR AND LINEAR MEASUREMENTS AS WITNESSED BY MONUMENTS SHOWN HEREON ARE TRUE AND CORRECT TO THE BEST OF MY KNOWLEDGE AND BELIEF.

Ralph M. Wallem

RALPH M. WALLEM

PLS NO. 80040185

NOTE: THIS DRAWING DOES NOT REPRESENT A BOUNDARY SURVEY.



PROJECT NUMBER:
20161506655

SITE NAME:
EV BARLOW

SITE ADDRESS:
2557 STEVE DENTON RD
BARLOW, KY 42024

LEASE AREA:
10000 SQ. FT.

PROPERTY OWNER:
MYATT FAMILY TRUST
CHARLES MYATT & DEENA MYATT, TRUSTEES
2224 STEVE DENTON ROAD
BARLOW, KENTUCKY 42024

TAX PARCEL ID:
24-30

COUNTY:
BALLARD COUNTY

SOURCE OF TITLE:
DEED BK 112, PG 227

LATITUDE: 37°06'42.145" N
LONGITUDE: 89°02'44.583" W

DWG BY:	CHKD BY:	DATE:
GVW	RMW	1.9.19

STATE OF KENTUCKY
RALPH M. WALLEM
2195
LICENSED PROFESSIONAL LAND SURVEYOR

NO.	REVISION/ISSUE	DATE:
1.	REVISED UPDATED	1.24.22

TITLE:
500' RADIUS & AJAINERS MAP

SHEET:
1 OF 1

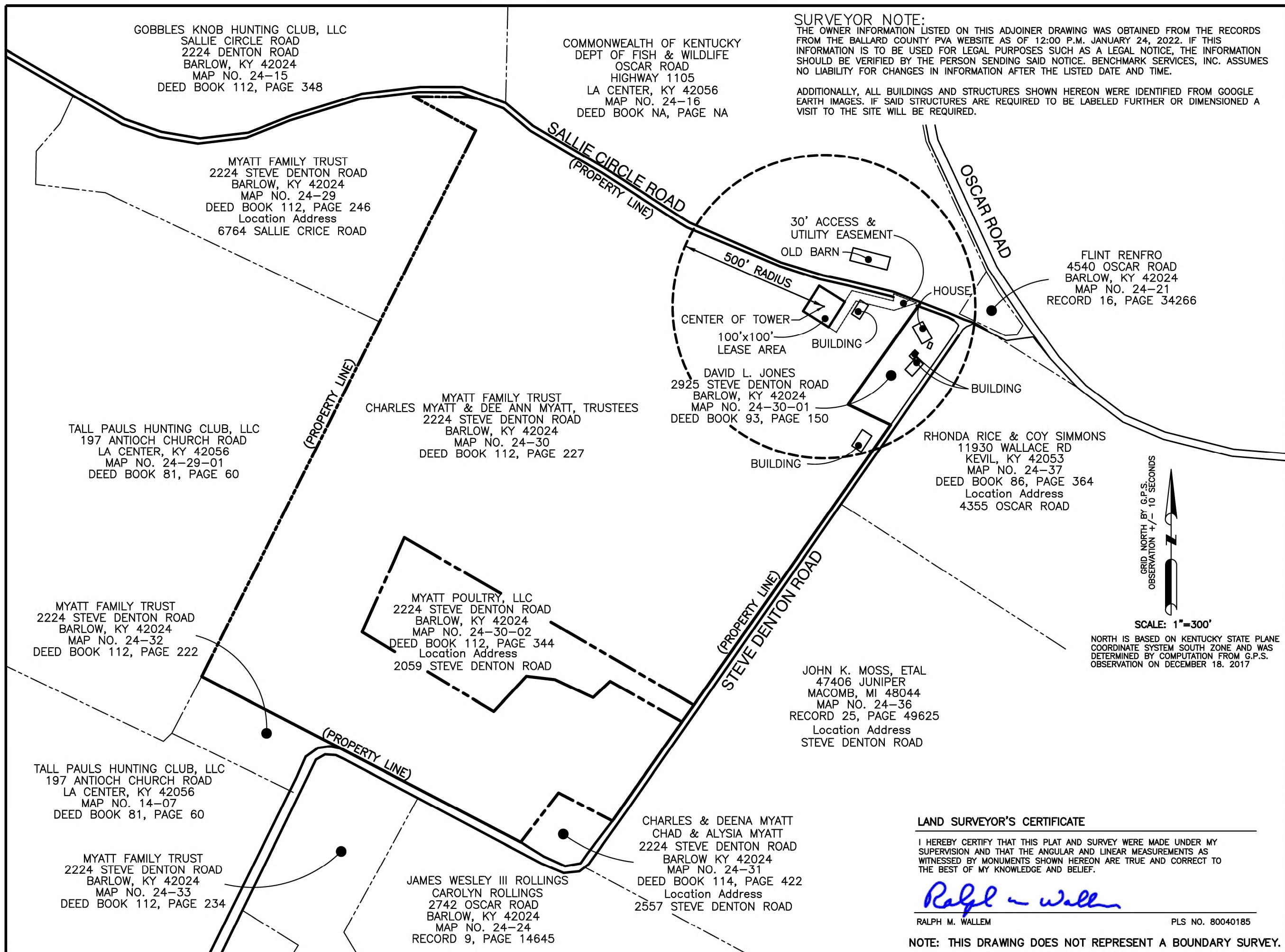

SCALE: 1"=300'

NORTH IS BASED ON KENTUCKY STATE PLANE COORDINATE SYSTEM SOUTH ZONE AND WAS DETERMINED BY COMPUTATION FROM G.P.S. OBSERVATION ON DECEMBER 18, 2017

SURVEYOR CERTIFICATE

TO: PIKE LEGAL GROUP
 AMERICAN TITLE COMPANY, INC FILE NO. CT-566
 COMMITMENT DATE: NOVEMBER 27, 2017 @8:00 AM
 SITE NAME: EV BARLOW "STEVE DENTON ROAD"



1961 NORTHPOINT BLVD.
 SUITE 130
 HIXSON, TN 37343



Consulting Engineers
 Land Surveyors
 338 North Main Street
 Henderson, TN 37057
 (615) 683-2043
 benchmark@bmsurvey.com

PROJECT NUMBER:
 20161506655

SITE NAME:
 EV BARLOW

SITE ADDRESS:
 2557 STEVE DENTON RD
 BARLOW, KY 42024

LEASE AREA:
 10000 SQ. FT.

PROPERTY OWNER:
 MYATT FAMILY TRUST
 CHARLES MYATT & DEENA MYATT, TRUSTEES
 2244 STEVE DENTON ROAD
 BARLOW, KENTUCKY 42024

TAX PARCEL ID:
 24-30

COUNTY:
 BALLARD COUNTY

SOURCE OF TITLE:
 DEED BK 112, PG 227

LATITUDE: 37° 08' 42.145" N
LONGITUDE: 89° 02' 44.583" W

DWG BY:	CHKD BY:	DATE:
GWW	RMW	12.22.17

NO.	REVISION/ISSUE	DATE:
1.	ADD TITLE ADD VERIZON LEASE ADD PARENT PARCEL	8.28.18
2.	REMOVE FLOOD ZONE NOTE	1.15.19

TITLE:
 SURVEY PLAN

SHEET:
 1 OF 3

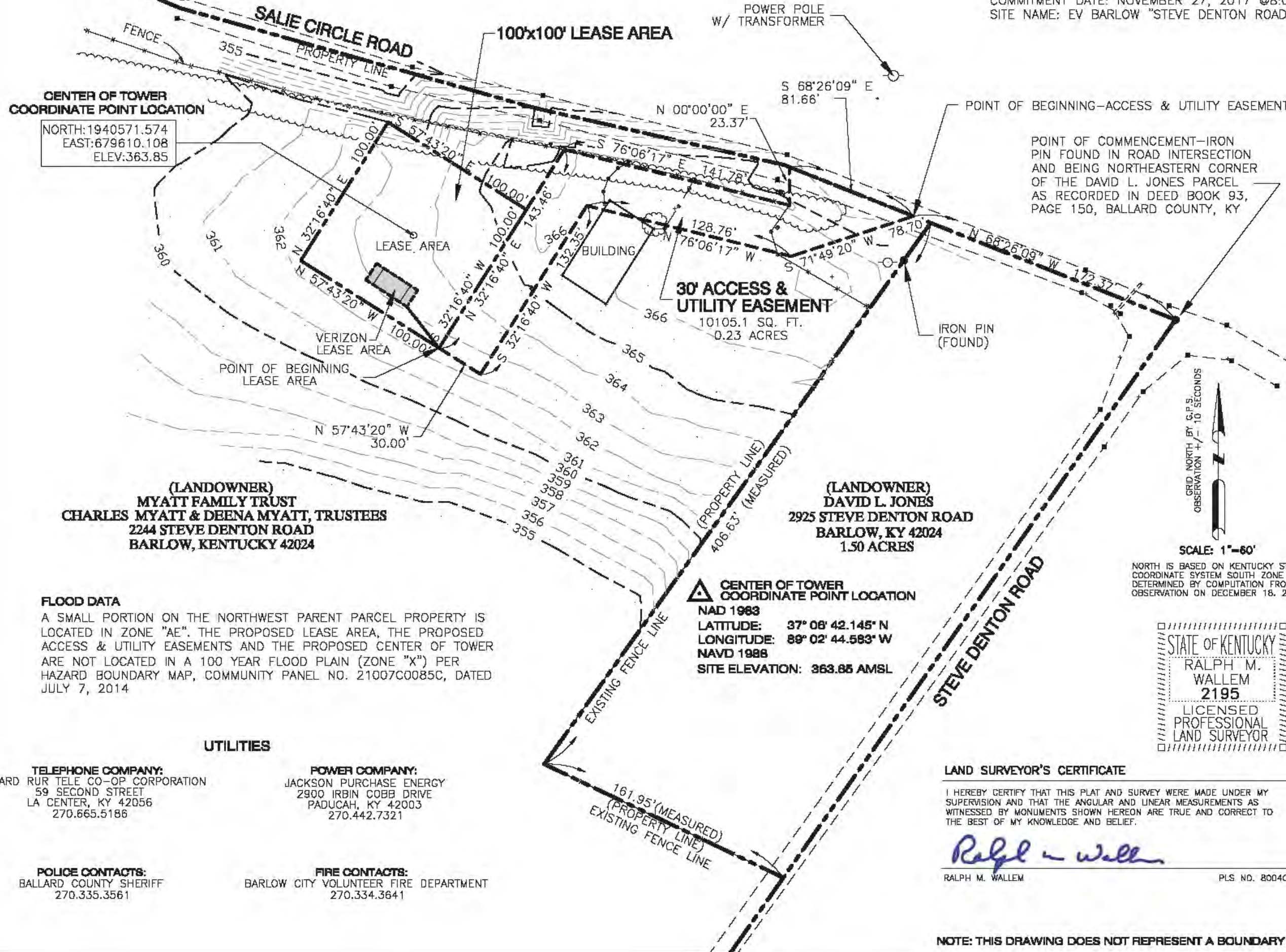

**CENTER OF TOWER
 COORDINATE POINT LOCATION**
 NORTH: 1940571.574
 EAST: 679610.108
 ELEV: 363.85

**POINT OF COMMENCEMENT—IRON
 PIN FOUND IN ROAD INTERSECTION
 AND BEING NORTHEASTERN CORNER
 OF THE DAVID L. JONES PARCEL
 AS RECORDED IN DEED BOOK 93,
 PAGE 150, BALLARD COUNTY, KY**

**30' ACCESS &
 UTILITY EASEMENT**
 10105.1 SQ. FT.
 0.23 ACRES



**CENTER OF TOWER
 COORDINATE POINT LOCATION**
 NAD 1983
 LATITUDE: 37° 08' 42.145" N
 LONGITUDE: 89° 02' 44.583" W
 NAVD 1988
 SITE ELEVATION: 363.85 AMSL

STATE OF KENTUCKY
 RALPH M. WALLEM
 2195
 LICENSED
 PROFESSIONAL
 LAND SURVEYOR

LAND SURVEYOR'S CERTIFICATE

I HEREBY CERTIFY THAT THIS PLAT AND SURVEY WERE MADE UNDER MY SUPERVISION AND THAT THE ANGULAR AND LINEAR MEASUREMENTS AS WITNESSED BY MONUMENTS SHOWN HEREON ARE TRUE AND CORRECT TO THE BEST OF MY KNOWLEDGE AND BELIEF.

Ralph M. Wallem
 RALPH M. WALLEM PLS. NO. 80040185

NOTE: THIS DRAWING DOES NOT REPRESENT A BOUNDARY SURVEY.

**(LANDOWNER)
 MYATT FAMILY TRUST
 CHARLES MYATT & DEENA MYATT, TRUSTEES
 2244 STEVE DENTON ROAD
 BARLOW, KENTUCKY 42024**

**(LANDOWNER)
 DAVID L. JONES
 2925 STEVE DENTON ROAD
 BARLOW, KY 42024
 1.50 ACRES**

FLOOD DATA
 A SMALL PORTION ON THE NORTHWEST PARENT PARCEL PROPERTY IS LOCATED IN ZONE "AE". THE PROPOSED LEASE AREA, THE PROPOSED ACCESS & UTILITY EASEMENTS AND THE PROPOSED CENTER OF TOWER ARE NOT LOCATED IN A 100 YEAR FLOOD PLAIN (ZONE "X") PER HAZARD BOUNDARY MAP, COMMUNITY PANEL NO. 21007C0085C, DATED JULY 7, 2014

UTILITIES

TELEPHONE COMPANY:
 BALLARD RUR TELE CO-OP CORPORATION
 59 SECOND STREET
 LA CENTER, KY 42056
 270.665.5186

POWER COMPANY:
 JACKSON PURCHASE ENERGY
 2900 IRBIN COBB DRIVE
 PADUCAH, KY 42003
 270.442.7321

POLICE CONTACTS:
 BALLARD COUNTY SHERIFF
 270.335.3561

FIRE CONTACTS:
 BARLOW CITY VOLUNTEER FIRE DEPARTMENT
 270.334.3641

SURVEYOR CERTIFICATE

TO: PIKE LEGAL GROUP
 AMERICAN TITLE COMPANY, INC FILE NO. CT-566
 COMMITMENT DATE: NOVEMBER 27, 2017 @8:00 AM
 SITE NAME: EV BARLOW "STEVE DENTON ROAD"
 GRANTEE: THE MYATT FAMILY TRUST
 DATE: NOVEMBER 16, 2016
 GRANTOR: CHARLES MYATT AND DEENA MYATT, HUSBAND & WIFE, AND CHARLES MYATT AS EXECUTOR OF THE ESTATE OF JIMMY MYATT
 BOOK/PAGE: 112, 227

SCHEDULE B-SECTION II
 I CERTIFY THAT THIS PLAT AND SURVEY WERE MADE UNDER MY SUPERVISION, AND THAT THE ANGULAR AND LINEAR MEASUREMENTS, AS WHITNESSED BY MONUMENTS SHOWN HEREON, ARE TRUE AND CORRECT TO THE BEST OF MY KNOWLEDGE AND BELIEF.
 THIS SURVEY AND PLAT MEETS OR EXCEEDS THE MINIMUM STANDARDS OF THE GOVERNING AUTHORITIES.

SURVEYOR STATEMENT-MY COMMENTS ARE BASED SOLELY ON THE TITLE DOCUMENT THAT HAVE BEEN SUPPLIED TO ME BY THE TITLE COMPANY. SINCE THE TITLE DOCUMENTS ARE FURNISHED FOR THE PARENT TRACT, OUR TOPOGRAPHIC SURVEY IS OF A PORTION OF THAT TRACT. MY COMMENTS ARE RESTRICTED TO EXCLUSIONS THAT I CAN DETERMINE AFFECT ONLY OUR PORTION OF THE PARENT TRACT. NO BOUNDARY SURVEY WAS PERFORMED ON THE PARENT TRACT, THUS IT IS NOT POSSIBLE TO DETERMINE WITH CERTAINTY EXCLUSIONS REFERENCING THE PARENT TRACT.

SCHEDULE "B" SECTION II EXCEPTIONS
 ITEM 1 -NOT A SURVEYOR RELATED ITEM.
 ITEM 2 -NOT A SURVEYOR RELATED ITEM.
 ITEM 3 -NOT A SURVEYOR RELATED ITEM.

Ralph M. Wallem
 END OF SCHEDULE B-II
 RALPH M. WALLEM INDIANA LAND SURVEYOR
 EFFECTIVE DATE: NOVEMBER 10, 2015

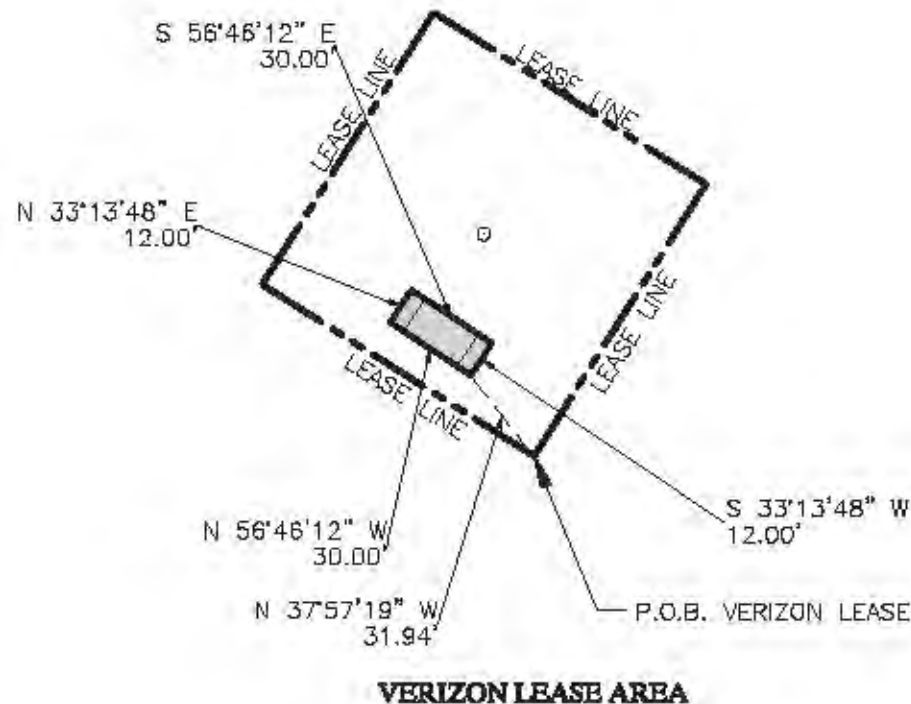

LEASE AREA DESCRIPTION

A PART OF A 69 ACRE PARCEL OF LAND OWNED BY THE MYATT FAMILY TRUST AS RECORDED IN DEED BOOK 112, PAGE 227, AND LYING SOUTHWEST OF THE INTERSECTION OF SALIE CIRCLE ROAD AND STEVE DENTON ROAD, BALLARD COUNTY, KENTUCKY.

COMMENCING AT AN IRON PIN FOUND AT THE INTERSECTION OF SAID SALIE CIRCLE ROAD AND STEVE DENTON ROAD, SAID POINT ALSO BEING THE NORTHEAST CORNER OF A PARCEL OF LAND OWNED BY DAVID L. JONES AS RECORDED IN DEED BOOK 93, PAGE 150, THENCE ALONG THE CENTERLINE OF SALIE CIRCLE ROAD NORTH 68 DEGREES 26 MINUTES 09 SECONDS WEST 172.37 FEET; THENCE SOUTH 71 DEGREES 49 MINUTES 20 SECONDS WEST 78.70 FEET; THENCE NORTH 76 DEGREES 06 MINUTES 17 SECONDS WEST 128.76 FEET; THENCE SOUTH 32 DEGREES 16 MINUTES 40 SECONDS WEST 132.35 FEET; THENCE NORTH 57 DEGREES 43 MINUTES 20 SECONDS WEST 30.00 FEET TO THE SOUTHERNMOST LEASE CORNER AND BEING THE TRUE PLACE OF BEGINNING OF THIS LEASE AREA DESCRIPTION; THENCE NORTH 57 DEGREES 43 MINUTES 20 SECONDS WEST 100.00 FEET; THENCE NORTH 32 DEGREES 16 MINUTES 40 SECONDS EAST 100.00 FEET; THENCE SOUTH 57 DEGREES 43 MINUTE 20 SECONDS EAST 100.00 FEET; THENCE SOUTH 32 DEGREES 16 MINUTES 40 SECONDS WEST 100.00 FEET TO THE TRUE PLACE OF BEGINNING AND CONTAINING 10,000 SQUARE FEET, (0.23 ACRES), MORE OR LESS.

30' ACCESS & UTILITY EASEMENT DESCRIPTION

A PART OF A 69 ACRE PARCEL OF LAND OWNED BY THE MYATT FAMILY TRUST AS RECORDED IN DEED BOOK 112, PAGE 227, AND LYING SOUTHWEST OF THE INTERSECTION OF SALIE CIRCLE ROAD AND STEVE DENTON ROAD, BALLARD COUNTY, KENTUCKY.

COMMENCING AT AN IRON PIN FOUND AT THE INTERSECTION OF SAID SALIE CIRCLE ROAD AND STEVE DENTON ROAD, SAID POINT ALSO BEING THE NORTHEAST CORNER OF A PARCEL OF LAND OWNED BY DAVID L. JONES AS RECORDED IN DEED BOOK 93, PAGE 150, THENCE ALONG THE CENTERLINE OF SALIE CIRCLE ROAD NORTH 68 DEGREES 26 MINUTES 09 SECONDS WEST 172.37 FEET TO THE TRUE PLACE OF BEGINNING OF THIS ACCESS AND EASEMENT DESCRIPTION; THENCE SOUTH 71 DEGREES 49 MINUTES 20 SECONDS WEST 78.70 FEET; THENCE NORTH 76 DEGREES 06 MINUTES 17 SECONDS WEST 128.76 FEET; THENCE SOUTH 32 DEGREES 16 MINUTES 40 SECONDS WEST 132.35 FEET; THENCE NORTH 57 DEGREES 43 MINUTES 20 SECONDS WEST 30.00 FEET TO THE SOUTHERNMOST LEASE CORNER; THENCE NORTH 32 DEGREES 16 MINUTES 40 SECONDS EAST 143.46 FEET; THENCE SOUTH 76 DEGREES 06 MINUTES 17 SECONDS EAST 141.78 FEET; THENCE NORTH 00 DEGREES 00 MINUTES 00 SECONDS EAST 23.37 FEET; THENCE SOUTH 68 DEGREES 26 MINUTES 09 SECONDS EAST 81.66 FEET TO THE TRUE PLACE OF BEGINNING AND CONTAINING 10,105.1 SQUARE FEET, (0.23 ACRES), MORE OR LESS.

VERIZON LEASE AREA DESCRIPTION

A PART OF A 69 ACRE PARCEL OF LAND OWNED BY THE MYATT FAMILY TRUST AS RECORDED IN DEED BOOK 112, PAGE 227, AND LYING SOUTHWEST OF THE INTERSECTION OF SALIE CIRCLE ROAD AND STEVE DENTON ROAD, BALLARD COUNTY, KENTUCKY.

COMMENCING AT AN IRON PIN FOUND AT THE INTERSECTION OF SAID SALIE CIRCLE ROAD AND STEVE DENTON ROAD, SAID POINT ALSO BEING THE NORTHEAST CORNER OF A PARCEL OF LAND OWNED BY DAVID L. JONES AS RECORDED IN DEED BOOK 93, PAGE 150, THENCE ALONG THE CENTERLINE OF SALIE CIRCLE ROAD NORTH 68 DEGREES 26 MINUTES 09 SECONDS WEST 172.37 FEET; THENCE SOUTH 71 DEGREES 49 MINUTES 20 SECONDS WEST 78.70 FEET; THENCE NORTH 76 DEGREES 06 MINUTES 17 SECONDS WEST 128.76 FEET; THENCE SOUTH 32 DEGREES 16 MINUTES 40 SECONDS WEST 132.35 FEET; THENCE NORTH 57 DEGREES 43 MINUTES 20 SECONDS WEST 30.00 FEET TO THE SOUTHERNMOST LEASE CORNER; THENCE NORTH 37 DEGREES 57 MINUTES 19 SECONDS WEST 31.94 FEET TO THE TRUE PLACE OF BEGINNING OF THIS VERIZON LEASE AREA; THENCE NORTH 56 DEGREES 46 MINUTES 12 SECONDS WEST 30.00 FEET; THENCE NORTH 33 DEGREES 13 MINUTES 48 SECONDS EAST 12.00 FEET; THENCE SOUTH 56 DEGREES 46 MINUTES 12 SECONDS EAST 30.00 FEET; THENCE SOUTH 33 DEGREES 13 MINUTES 48 SECONDS WEST 12.00 FEET AND CONTAINING 360 SQUARE FEET.



1961 NORTHPOINT BLVD.
 SUITE 130
 HIXSON, TN 37343



PROJECT NUMBER:
 20161506855

SITE NAME:
 EV BARLOW

SITE ADDRESS:
 2557 STEVE DENTON RD
 BARLOW, KY 42024

LEASE AREA:
 10000 SQ. FT.

PROPERTY OWNER:
 MYATT FAMILY TRUST
 CHARLES MYATT & DEENA MYATT, TRUSTEES
 2244 STEVE DENTON ROAD
 BARLOW, KENTUCKY 42024

TAX PARCEL ID:
 24-30

COUNTY:
 BALLARD COUNTY

SOURCE OF TITLE:
 DEED BK 112, PG 227

LATITUDE: 37° 06' 42.146" N
 LONGITUDE: 89° 02' 44.583" W

DWG BY:	CHKD BY:	DATE:
GWW	RMW	12.22.17

NO.	REVISION/ISSUE	DATE:
1.	ADD TITLE ADD VERIZON LEASE ADD PARENT PARCEL	6.28.18
2.	REMOVE ZONE NOTE	1.15.18

TITLE:
 SURVEY PLAN

SHEET:
 2 OF 3

PARENT PARCEL DESCRIPTION

TRACT NO 1: BEGINNING AT A STAKE IN THE CORNER OF THE HULDA CRICE TRACT WITH DOUBLE WHITE OAK, SOUTH 41 DEG. WEST 13 LINKS, BLACK OAK NORTH 18½ DEG. EAST 30 LINKS; THENCE NORTH 71 DEG. WEST 58 POLES TO A STAKE IN TERRELL'S LINE; THENCE NORTH 18½ DEG. EAST WITH TERRELL LINE 127 POLS TO A STAKE IN THE CENTER OF THE TERRELL LANDING ROAD, SASSAFRAS SOUTH 46 DEG. WEST 1 POLE AND LARGE WHITE OAK NORTH 18 DEG. EAST 2 POLES AND 87 LINKS; THENCE SOUTH 84 DEG. EAST WITH THE CENTER OF SAID ROAD 84 POLES TO A STAKE IN HULDA CRICE'S LINE; THENCE SOUTH 28 DEG. WEST 134 POLES TO THE BEGINNING, CONTAINING 56 ACRES AND 34 POLES, MORE OR LESS. SUBJECT TO LEGAL HIGHWAYS.

EXCEPTION NO. 1; LESS AND EXCEPT HOWEVER, A ONE ACRE TRACT OF LAND CONVEYED BY WILLIAM B. WATSON TO JIMMIE MYATT BY DEED DATED JANUARY 27, 1960, DEED BOOK 64, PAGE 250 AND DESCRIBED AS FOLLOWS; BEGINNING AT A STAKE AT THE SOUTHEAST CORNER OF A 56 ACRE TRACT OF LAND, SAID STAKE BEING THE CENTER OF AND AT A TURN OF A COUNTY GRAVEL ROAD KNOWN AS STEVE DENTON ROAD; THENCE NORTH 71 DEG. WEST 210 FEET TO A STAKE IN THE CENTER OF SAID ROAD; THENCE NORTH 18½ DEG. WEST 210 FEET WITH THE CENTER OF STEVE DENTON ROAD TO THE POINT OF BEGINNING, CONTAINING ONE (1) ACRE, AND BEING ONE ACRE OUT OF THE SOUTHEAST CORNER OF THE 56 ACRE TRACT.

EXCEPTION NO. 2; LESS AND EXCEPT HOWEVER, A ONE AND ONE-HALF ACRE TRACT OF LAND CONVEYED BY BILLIE EVELYN EWING AND HUSBAND, BILL N. EWING TO DAVID JONES BY DEED DATED APRIL 19, 1984 OF RECORD IN MICROFILM CABINET 1, DRAWER 9, CARD NO. _____ AND DESCRIBED AS FOLLOWS: BEGINNING AT A POINT IN THE CENTER OF THE TERRELL LANDING COUNTY ROAD, SAID POINT BEING THE CENTER OF THE DENTON COUNTY ROAD SOUTH 30 DEG. WEST 413 FEET TO A NEW CORNER IN THE HENRY ADAMS TRACT OF LAND; THENCE ON A NEW LINE WITH THE ADAMS LAND NORTH 80 DEG. WEST 160 FEET; THENCE NORTH 30 DEG. EAST 413 FEET TO A POINT IN THE CENTER OF TERRELL LANDING COUNTY GRAVEL ROAD; THENCE WITH THE CENTER OF SAID ROAD SOUTH 80 DEG. EAST 160 FEET TO THE POINT OF BEGINNING AND CONTAINING ONE AND ONE HALF ACRES, MORE OR LESS, ACCORDING TO A SURVEY MADE APRIL 13, 1983 BY B. ALLIE, SURVEYOR, WICKLIFFE, KENTUCKY.

TRACT NO. 2: BEGINNING AT A BLACK OAK ON THE BANK OF A RAVINE, IN TERRELL'S LINE; THENCE NORTH 18 DEG. EAST 5½ POLES TO A STAKE IN THE CENTER OF TERRELL LANDING ROAD, SASSAFRAS AND WHITE OAK POINTERS; THENCE NORTH 65 DEG. WEST 33 POLES TO A STAKE IN THE RAVINE; THENCE SOUTH 82 DEG. WEST 20 POLES TO THE INTERSECTION OF THE TERRELL LINE; THENCE WITH TERRELL'S LINE IN A SOUTHERN DIRECTION TO THE BEGINNING AND CONTAINING 2½ ACRES, MORE OR LESS, SUBJECT TO LEGAL HIGHWAYS.

TRACT NO. 3: BEGINNING AT A STAKE IN THE NORTHEAST CORNER OF THE ORIGINAL 191½ ACRE TRACT OF LAND OWNED BY J.H. CRICE; THENCE SOUTH 20 DEG. WEST 132½ POLES; THENCE NORTH 71 DEG. WEST 27.17 POLES TO A STAKE, A NEW CORNER; THENCE NORTH 20 DEG. EAST 132½ POLES TO A STAKE IN THE NORTH LINE OF THE ORIGINAL J.H. CRICE TRACT OF LAND; THENCE SOUTH 72 DEG. EAST 27.17 POLES TO THE BEGINNING, CONTAINING 22½ ACRES, MORE OR LESS, BY ACTUAL SURVEY MADE BY D.W. JUDD, MCCrackEN COUNTY SURVEYOR, IN YEAR 1938, BUT SUBJECT TO ALL LEGAL HIGHWAYS.

LESS AND EXCEPT HOWEVER, A TWO ACRE TRACT OF LAND CONVEYED BY JESSIE C. HOWLE AND HUSBAND, A.K. HOWLE TO JESSIE ROSS BY DEED DATED MAY 7, 1945, DEED BOOK 51, PAGE 212, AND DESCRIBED AS FOLLOWS: BEGINNING AT A STAKE IN THE ROAD AT THE SOUTHEAST CORNER OF THE 22½ ACRE TRACT; THENCE NORTH 71 DEG. WEST 450 FEET TO THE SOUTHWEST CORNER OF THE 22½ ACRE TRACT; THENCE NORTH 20 DEG. EAST APPROXIMATELY 195 FEET TO A STAKE, A NEW CORNER, THENCE SOUTH 71 DEG. EAST 450 FEET TO A STAKE, THE SOUTHWEST CORNER OF THE 56 ACRE TRACT; THENCE SOUTH 20 DEG. WEST APPROXIMATELY 195 FEET TO THE PLACE OF BEGINNING, CONTAINING TWO (2) ACRES, MORE OR LESS, SUBJECT TO ALL LEGAL HIGHWAYS.

BEING IN ALL RESPECTS THE SAME PROPERTY CONVEYED TO JIMMIE MYATT AND WIFE, ETHEL MYATT, S ONE-HALF (½) INTEREST, AND CHARLES MYATT AND WIFE, DEENA MYATT, A ONE-HALF (½) INTEREST, BY DEED DATED APRIL 19, 1984, RECORDED IN CABINET 1, DRAWER 9, CARD 16, 1128 BALLARD COUNTY CLERK'S OFFICE. ETHEL MYATT PREDECEASED JIMMIE MYATT. UPON HER DEATH THIER ONE-HALF (½) IN THE PROPERTY FULLY VESTED IN JIMMIE MYATT PURSUANT TO THE SURVIVORSHIP CLAUSE STATED IN THE AFORESAID DEED. JIMMIE MYATT IS NOW DESEASED. PURSUANT TO THE TERMS OF THE LAST WILL AND TESTAMENT OF JIMMIE MYATT RECORDED IN WILL BOOK 6, PAGE 71, CHARLES MYATT IS APPOINTED AS EXECUTOR WITH THE POWER TO TRANSFER REAL ESTATE.

TO HAVE AND TO HOLD THE ABOVE PREMISES, TOGETHER WITH ALL APPURTENANCES THEREUNTO BELONGING, TO THE GRANTEE, ITS SUCCESSORS AND ASSIGNS FOREVER.

PARENT PARCEL DEED DESCRIPTION FURNISHED TO BENCHMARK SERVICES, INC. NO BOUNDARY SURVEY WAS PERFORMED TO CREATE THIS LEASE/ACCESS AREA.



1961 NORTHPOINT BLVD.
SUITE 130
HIXSON, TN 37343



PROJECT NUMBER:
20181508855

SITE NAME:
EV BARLOW

SITE ADDRESS:
**2557 STEVE DENTON RD
BARLOW, KY 42024**

LEASE AREA:
10000 SQ. FT.

PROPERTY OWNER:
**MYATT FAMILY TRUST
CHARLES MYATT & DEENA MYATT, TRUSTEES
2244 STEVE DENTON ROAD
BARLOW, KENTUCKY 42024**

TAX PARCEL ID:
24-30

COUNTY:
BALLARD COUNTY

SOURCE OF TITLE:
DEED BK 112, PG 227

LATITUDE: **37° 06' 42.146" N**
LONGITUDE: **89° 02' 44.583" W**

DWG BY:	CHKD BY:	DATE:
GWW	RMW	12.22.17

NO.	REVISION/ISSUE	DATE:
1.	ADD TITLE ADD VERBEN LINE ADD PARENT PARCEL	8.28.18
2.	REMOVE ZONE NOTE	1.15.19

TITLE:
SURVEY PLAN

SHEET:
3 OF 3

REVISION LOG

REV*	MM/DD/YY	SHEET NUMBER & NAME
A	10/31/18	<ul style="list-style-type: none"> ISSUED FOR REVIEW
B	01/22/19	<ul style="list-style-type: none"> ADDED DISTANCE TO HOUSE
C	01/24/19	<ul style="list-style-type: none"> CALLED OUT ALL BUILDINGS ON OVERALL PLANS REVISED TITLE OF SHEET C-1B TO "TOWER DISTANCE TO PROPERTY LINES AND RESIDENTIAL STRUCTURES" REVISED SHEET INDEX TO REFLECT SHEET C-1B TITLE CHANGE
0	02/08/19	<ul style="list-style-type: none"> FINAL CONSTRUCTION DRAWINGS

GPD GROUP, INC.
 520 South Main Street, Suite 2531
 Akron, OH 44311
 330.572.2100 Fax: 330.572.2102

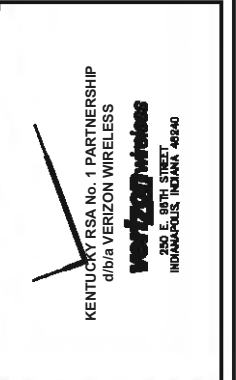

REV	DATE	DESCRIPTION
A	10/31/18	ISSUED FOR 90% REVIEW
B	01/22/19	ADDED DISTANCE TO HOUSE
C	01/24/19	CALLING OUT BUILDINGS AND RESIDENTIAL STRUCTURES
0	02/08/19	FINAL CONSTRUCTION DRAWINGS



EV BARLOW
 2557 STEVE DENTON ROAD
 BARLOW, KY 42024

REVISION LOG

ISSUED FOR:	
REVIEW	--
PERMIT	--
CONSTRUCTION	--
RECORD	--

PROJECT MANAGER	DESIGNER
TTP	DTC

JOB NO.
2017770.39

R-1

Drawing Name: O:\2017\201777039\EV Barlow\AEC\DEV Barlow CD.dwg
February 8, 2019 2:6 PM - skrschneer

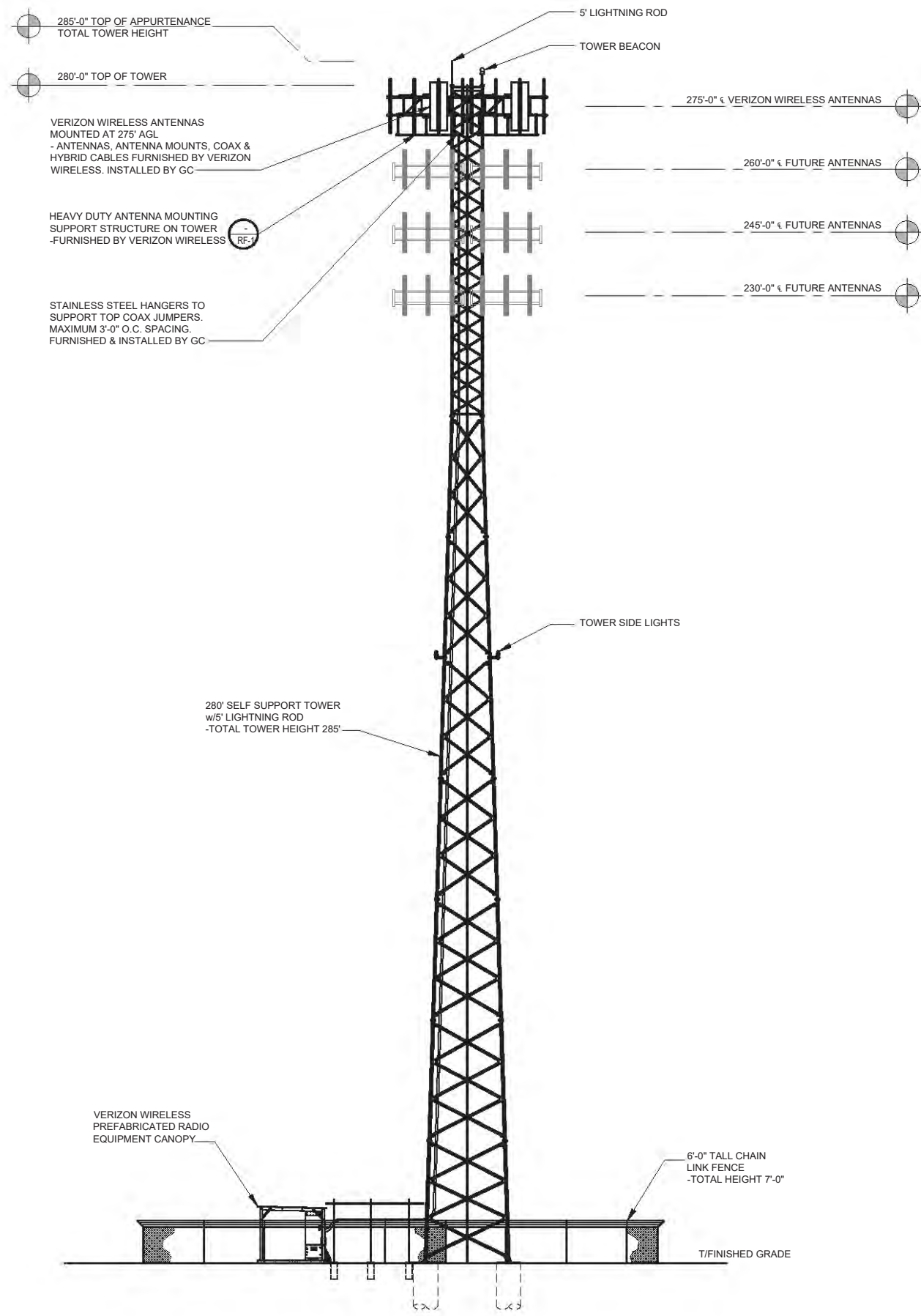

TOWER ELEVATION
SCALE: N.T.S. 1
TE-1

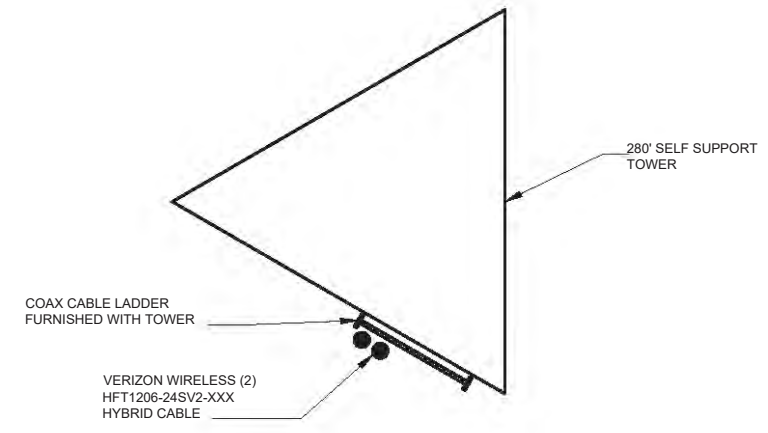

COAX PLAN
SCALE: N.T.S. NORTH

NOTE:
1. IT IS THE INSTALLING CONTRACTOR'S RESPONSIBILITY TO VERIFY ALL ANTENNA INFORMATION AGAINST FINAL RADIO ENGINEERING PLAN PROVIDED BY KENTUCKY RSA No. 1 PARTNERSHIP d/b/a VERIZON WIRELESS
2. ALL TOWER LIGHTING SHALL BE INSTALLED AS REQUIRED BY THE FEDERAL AVIATION ADMINISTRATION AND RECOMMENDED BY THE USFWS INTERIM GUIDELINES (2000) FOR LIGHTING OF TOWERS OVER 200' IN HEIGHT.

GPD GROUP, INC.
520 South Main Street, Suite 2531
Akron, OH 44311
330.572.2100 Fax: 330.572.2102

KENTUCKY RSA No. 1 PARTNERSHIP
d/b/a VERIZON WIRELESS
INDIANAPOLIS, INDIANA 46240



REV	DATE	DESCRIPTION
A	10/2/18	ISSUED FOR 90% REVIEW
B	07/27/19	ISSUED DISTANCE TO HOUSE
C	07/27/19	REBUILDING CALL OUTS AND REVISED SHEET TITLE
D	07/27/19	FINAL CONSTRUCTION DRAWINGS

EV BARLOW
2557 STEVE DENTON ROAD
BARLOW, KY 42024
TOWER ELEVATION

ISSUED FOR:	
REVIEW	--
PERMIT	--
CONSTRUCTION	--
RECORD	--
PROJECT MANAGER	DESIGNER
TTP	DTC

JOB NO.
2017770.39

TE-1

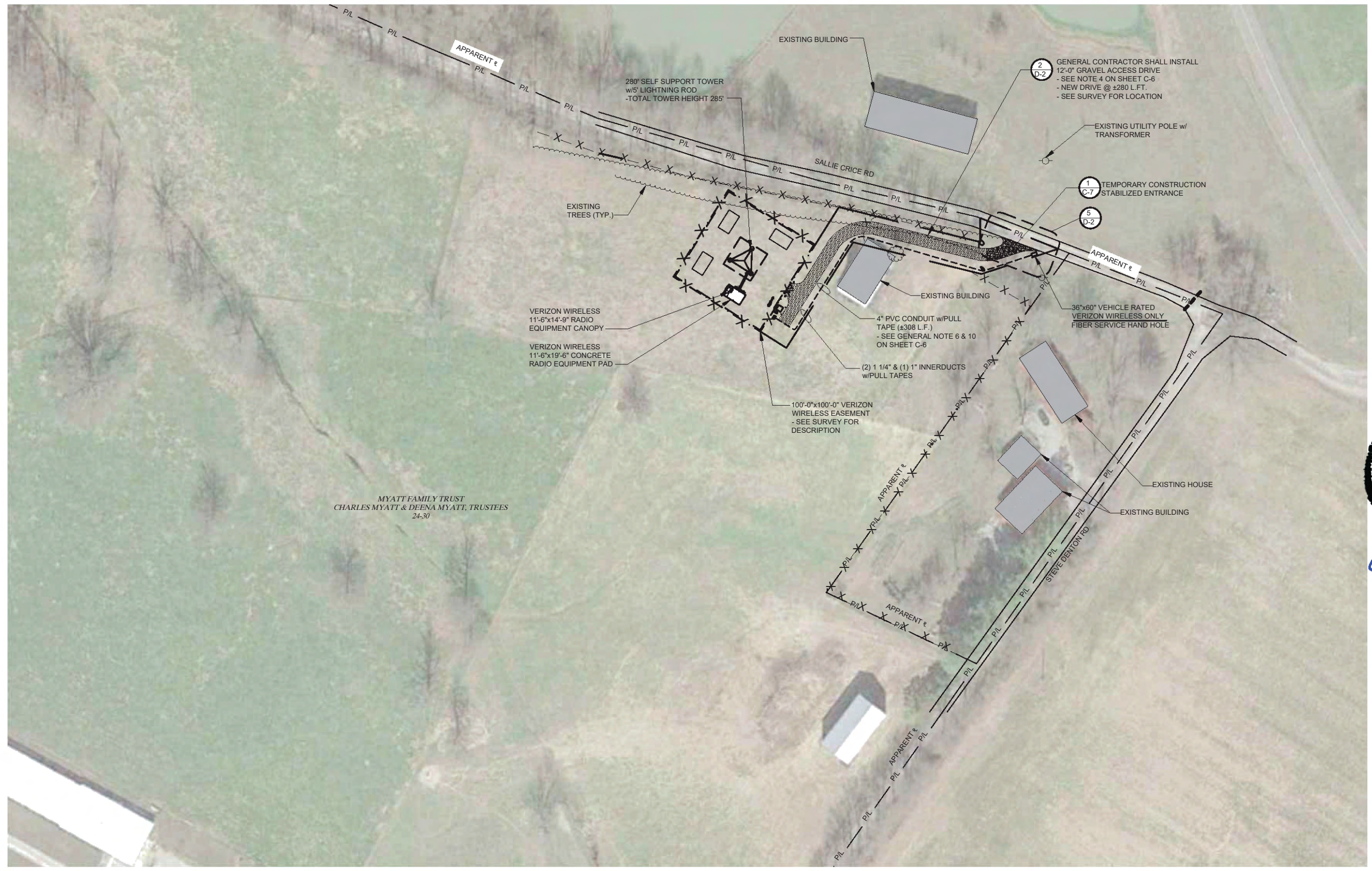

MYATT FAMILY TRUST
 CHARLES MYATT & DEENA MYATT, TRUSTEES
 24-30

2 D-2 GENERAL CONTRACTOR SHALL INSTALL
 12'-0" GRAVEL ACCESS DRIVE
 - SEE NOTE 4 ON SHEET C-6
 - NEW DRIVE @ ±280 L.F.T.
 - SEE SURVEY FOR LOCATION

1 C-7 TEMPORARY CONSTRUCTION
 STABILIZED ENTRANCE

5 D-2

VERIZON WIRELESS
 11'-6"x14'-9" RADIO
 EQUIPMENT CANOPY

VERIZON WIRELESS
 11'-6"x19'-6" CONCRETE
 RADIO EQUIPMENT PAD

4" PVC CONDUIT w/PULL
 TAPE (±308 L.F.)
 - SEE GENERAL NOTE 6 & 10
 ON SHEET C-6

(2) 1 1/4" & (1) 1" INNERDUCTS
 w/PULL TAPES

100'-0"x100'-0" VERIZON
 WIRELESS EASEMENT
 - SEE SURVEY FOR
 DESCRIPTION

36"x60" VEHICLE RATED
 VERIZON WIRELESS ONLY
 FIBER SERVICE HAND HOLE

EXISTING HOUSE

EXISTING BUILDING

EXISTING BUILDING

EXISTING BUILDING

SALLIE CRICE RD

STEVE DENTON RD

APPARENT E

APPARENT E

APPARENT E

APPARENT E

APPARENT E

REV	DATE	DESCRIPTION
A	10/27/17	REVISED FOR 90% REVIEW
B	07/27/18	REVISED DISTANCE TO HOUSE
C	07/27/18	REVISED BUILDING FOOTPRINT AND REVISIONS
D	07/27/18	REVISED CONSTRUCTION DRAWINGS

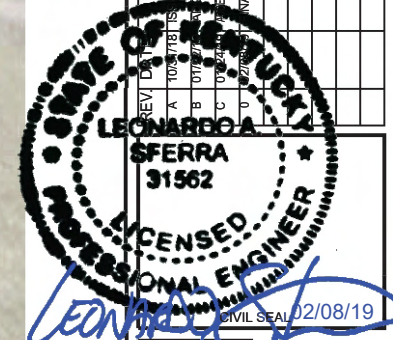

EV BARLOW
 2557 STEVE DENTON ROAD
 BARLOW, KY 42024
**OVERALL SITE PLAN w/
 AERIAL OVERLAY**

ISSUED FOR:	
REVIEW	--
PERMIT	--
CONSTRUCTION	--
RECORD	--

PROJECT MANAGER	DESIGNER
TTP	DTC

JOB NO.
2017770.39

C-1

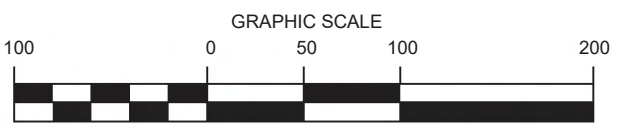

**OVERALL SITE PLAN
 w/AERIAL OVERLAY**

SCALE: 1" = 100'



Drawing Name: O:\2017\201777039\EV Barlow\AEC\DEV Barlow CD.dwg
 February 8, 2019 2:6 PM - skrschner

GPD GROUP, INC.
 520 South Main Street, Suite 2531
 Akron, OH 44311
 330.572.2100 Fax: 330.572.2102

KENTUCKY RSA No. 1 PARTNERSHIP
Verizon Wireless
 db/a VERIZON WIRELESS
 1000 W. MARKET, SUITE 400
 INDIANAPOLIS, IN 46204

NO.	DESCRIPTION	DATE
A	REVISED FOR 90% REVIEW	
B	REVISED DISTANCE TO HOUSE	
C	REVISED DISTANCE TO HOUSE	
D	REVISED DISTANCE TO HOUSE	
E	REVISED DISTANCE TO HOUSE	
F	REVISED DISTANCE TO HOUSE	
G	REVISED DISTANCE TO HOUSE	
H	REVISED DISTANCE TO HOUSE	
I	REVISED DISTANCE TO HOUSE	
J	REVISED DISTANCE TO HOUSE	
K	REVISED DISTANCE TO HOUSE	
L	REVISED DISTANCE TO HOUSE	
M	REVISED DISTANCE TO HOUSE	
N	REVISED DISTANCE TO HOUSE	
O	REVISED DISTANCE TO HOUSE	
P	REVISED DISTANCE TO HOUSE	
Q	REVISED DISTANCE TO HOUSE	
R	REVISED DISTANCE TO HOUSE	
S	REVISED DISTANCE TO HOUSE	
T	REVISED DISTANCE TO HOUSE	
U	REVISED DISTANCE TO HOUSE	
V	REVISED DISTANCE TO HOUSE	
W	REVISED DISTANCE TO HOUSE	
X	REVISED DISTANCE TO HOUSE	
Y	REVISED DISTANCE TO HOUSE	
Z	REVISED DISTANCE TO HOUSE	

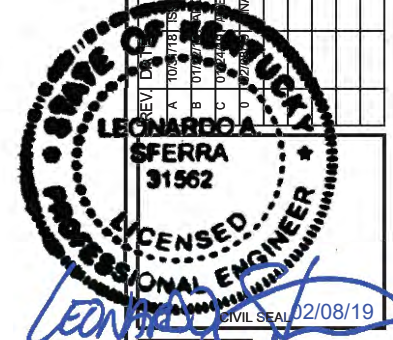

EV BARLOW
 2557 STEVE DENTON ROAD
 BARLOW, KY 42024
**OVERALL SITE PLAN w/
 PAD DISTANCE TO
 PROPERTY LINES**

ISSUED FOR:	
REVIEW	--
PERMIT	--
CONSTRUCTION	--
RECORD	--

PROJECT MANAGER	DESIGNER
TTP	DTC

JOB NO.
2017770.39

C-1A

Kentucky 811
 Know what's below.
 Call before you dig.
 Call Monday thru Friday, 7 am - 6 p.m.
 1-800-752-6007
PER KENTUCKY STATE LAW, IT IS AGAINST THE LAW
 TO EXCAVATE WITHOUT NOTIFYING THE
 UNDERGROUND LOCATION SERVICE TWO (2)
 WORKING DAYS BEFORE COMMENCING WORK.

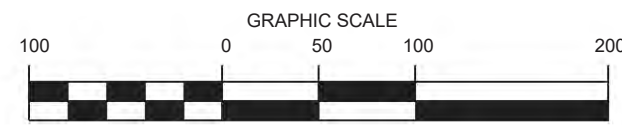
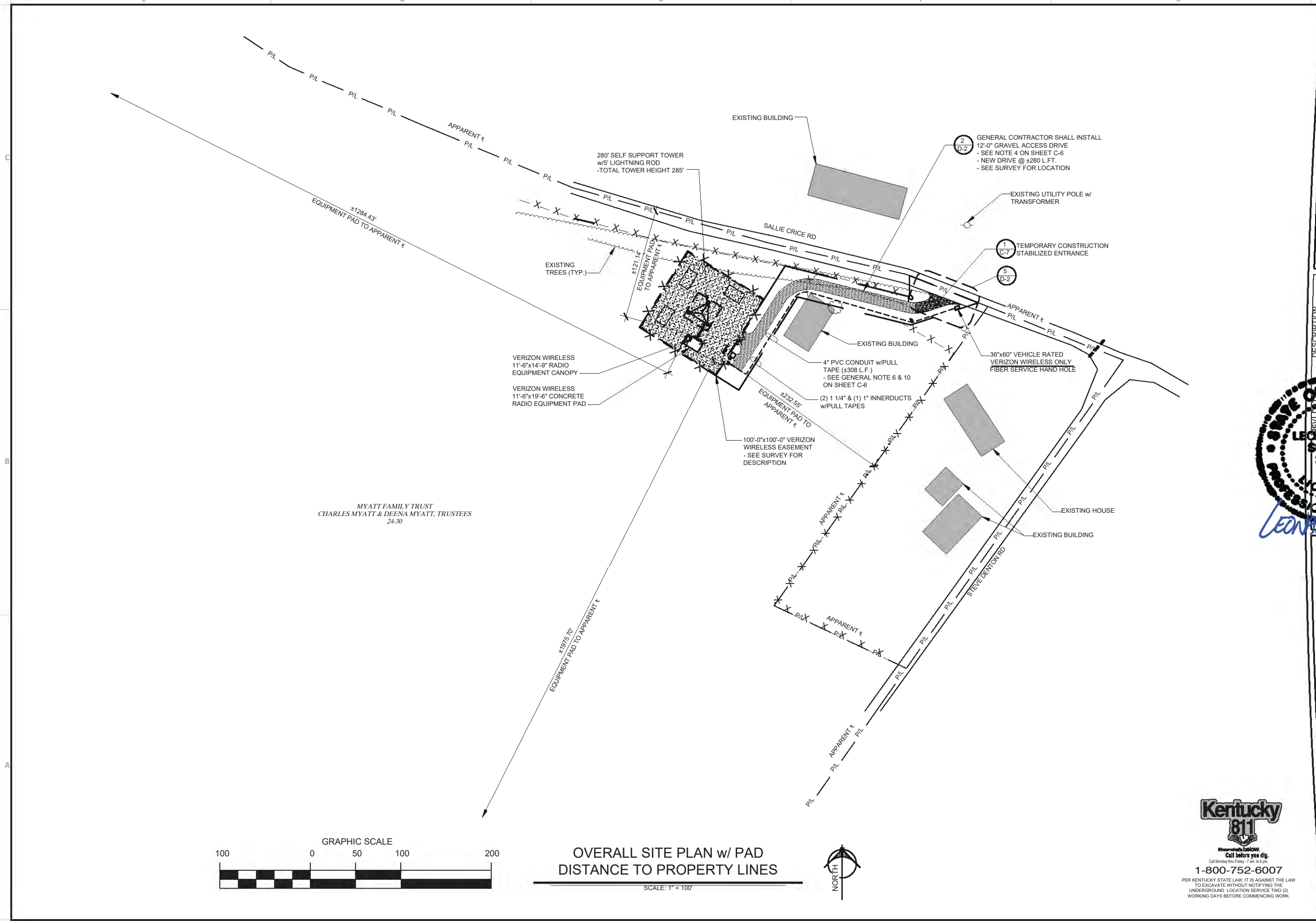

**OVERALL SITE PLAN w/ PAD
 DISTANCE TO PROPERTY LINES**

SCALE: 1" = 100'



Drawing Name: O:\2017\201777039\EV Barlow\AEC\DEV Barlow CD.dwg
 February 8, 2019 2:6 PM - skrschneer

KENTUCKY RSA No. 1 PARTNERSHIP
Verizon Wireless
 d/b/a VERIZON WIRELESS
 1000 W. MARKET ST., SUITE 400
 INDIANAPOLIS, IN 46204

NO.	DESCRIPTION	DATE	BY
1	ISSUED FOR PERMIT		
2	REVISION		

STATE OF KENTUCKY
LEONARDO SFERRA
 31562
 LICENSED PROFESSIONAL ENGINEER
 CIVIL SEAL 02/08/19

EV BARLOW
 2557 STEVE DENTON ROAD
 BARLOW, KY 42024
**TOWER DISTANCE TO
 PROPERTY LINES AND
 RESIDENTIAL STRUCTURES**

ISSUED FOR:	
REVIEW	--
PERMIT	--
CONSTRUCTION	--
RECORD	--

PROJECT MANAGER	DESIGNER
TTP	DTC

JOB NO.
2017770.39

C-1B

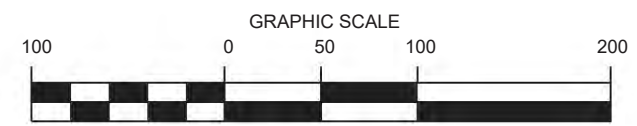
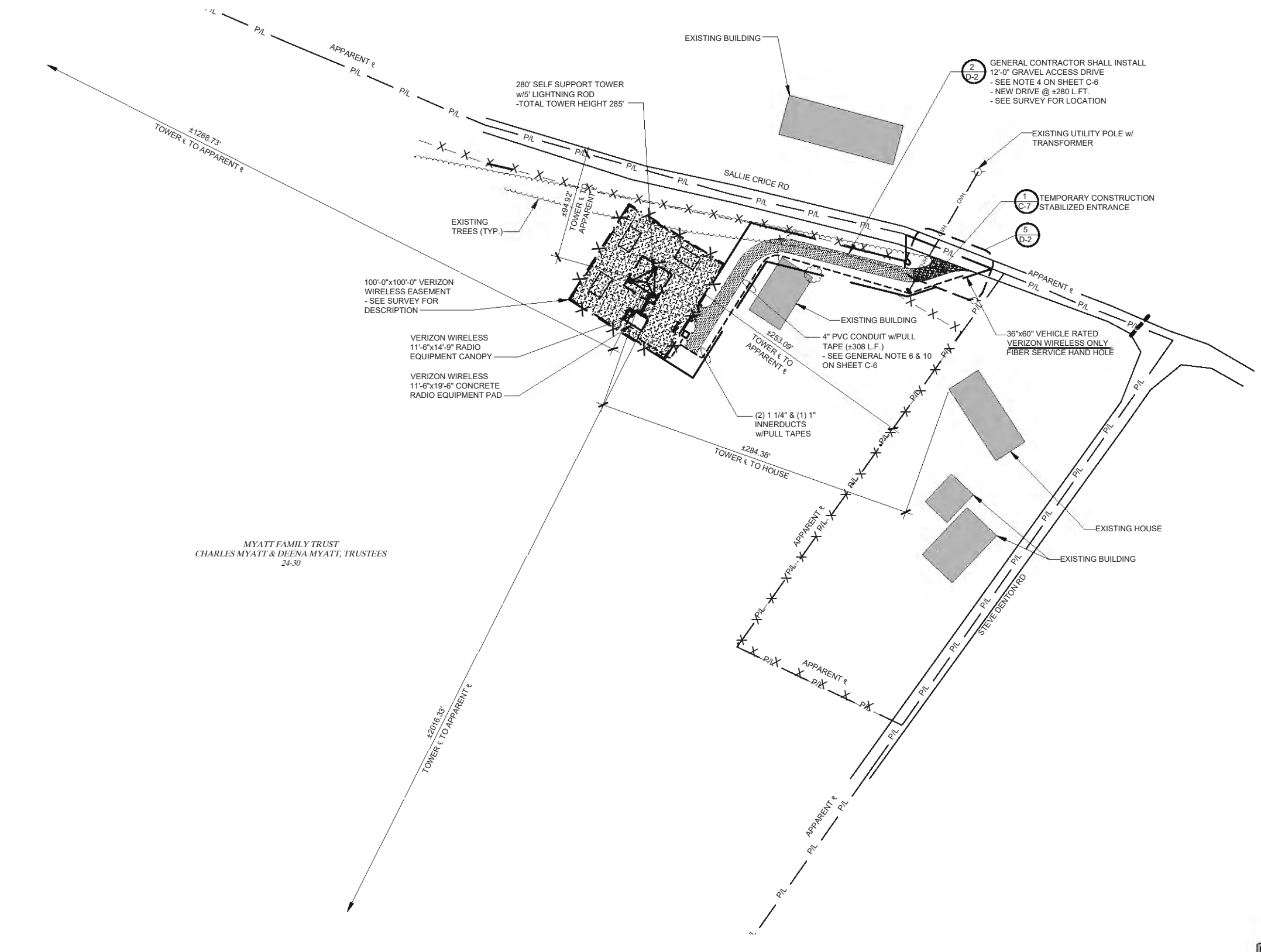

**TOWER DISTANCE TO
 PROPERTY LINES AND
 RESIDENTIAL STRUCTURES**
 SCALE: 1" = 100'



Kentucky 811
 Know what's below. Call before you dig.
 Call Monday thru Friday - 7 am to 6 pm
 1-800-752-6007
PER KENTUCKY STATE LAW, IT IS AGAINST THE LAW TO EXCAVATE WITHOUT NOTIFYING THE UNDERGROUND LOCATION SERVICE TWO (2) WORKING DAYS BEFORE COMMENCING WORK.

KENTUCKY RSA No. 1 PARTNERSHIP
 d/b/a VERIZON WIRELESS
 VERIZON WIRELESS
 10000 W. WILSON AVENUE
 INDIANAPOLIS, IN 46240

NO.	DATE	DESCRIPTION
A	10/2/18	ISSUED FOR 90% REVIEW
B	07/17/19	ISSUED FOR DISTANCE TO HOUSE
C	07/17/19	ISSUED FOR BUILDING CALCULATIONS AND REVISIONS
D	07/17/19	ISSUED FOR FINAL CONSTRUCTION DRAWINGS



EV BARLOW
 2557 STEVE DENTON ROAD
 BARLOW, KY 42024
**GRADING AND E&S
 CONTROL PLAN**

ISSUED FOR:	
REVIEW	--
PERMIT	--
CONSTRUCTION	--
RECORD	--

PROJECT MANAGER	DESIGNER
TTP	DTC

JOB NO.
2017770.39

C-2

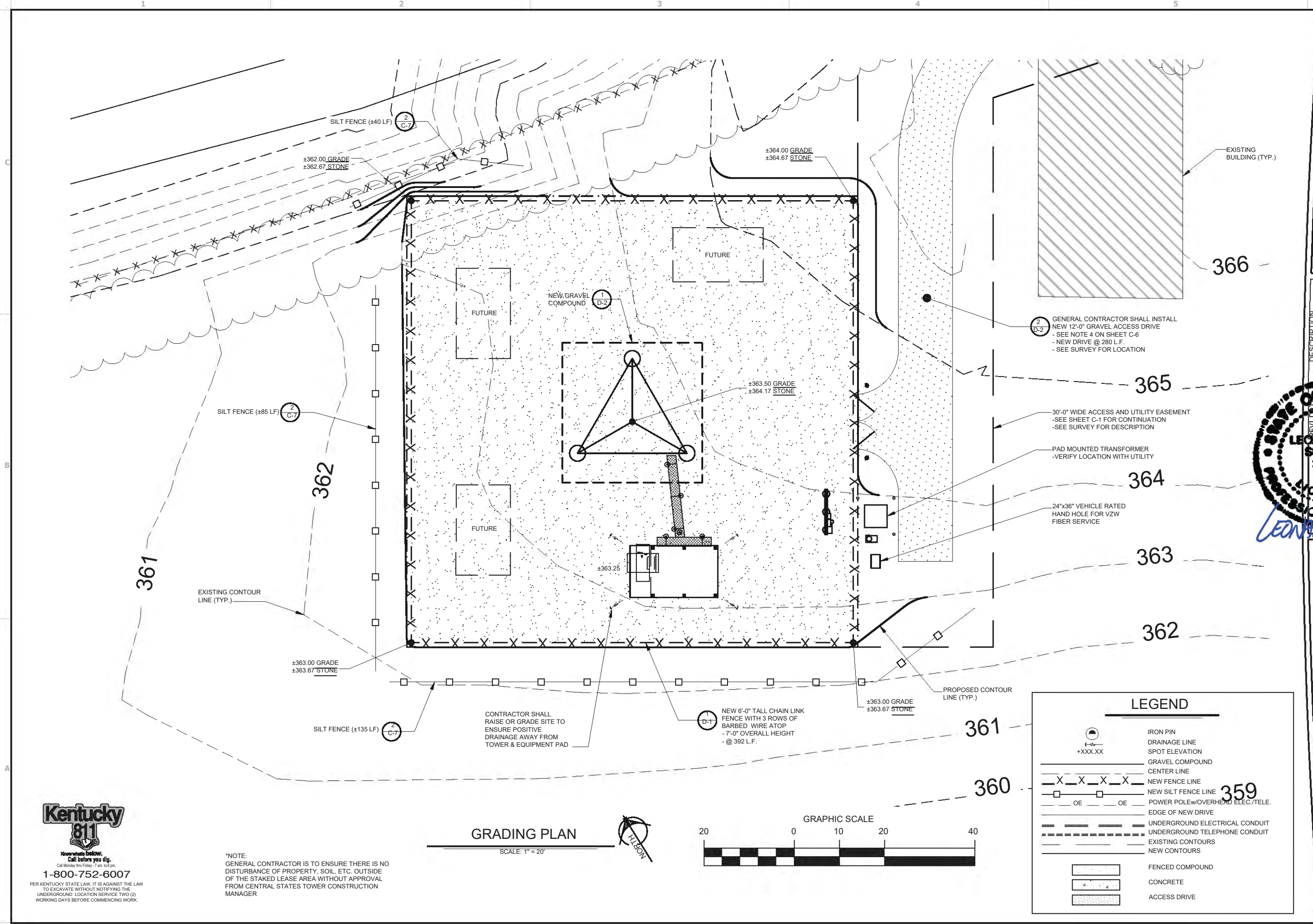

Drawing Name: C:\2017\201777039\EV Barlow\AE\CD\EV Barlow CD.dwg
 February 8, 2019 2:6 PM - skrschneer

Kentucky 811
 Know what's below.
 Call before you dig.
 Call Monday thru Friday - 7 am. to 5 pm.
 1-800-752-6007

PER KENTUCKY STATE LAW, IT IS AGAINST THE LAW TO EXCAVATE WITHOUT NOTIFYING THE UNDERGROUND LOCATION SERVICE TWO (2) WORKING DAYS BEFORE COMMENCING WORK.

KENTUCKY RSA No. 1 PARTNERSHIP
 d/b/a VERIZON WIRELESS

 10000 VERIZON WAY
 INDIANAPOLIS, IN 46240

NO.	DESCRIPTION	DATE
1	ISSUED FOR REVIEW FOR 90% REVIEW	
2	ISSUED FOR PERMIT	
3	ISSUED FOR CONSTRUCTION	
4	ISSUED FOR RECORD	

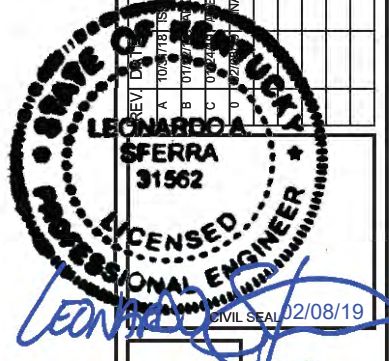

EV BARLOW
 2557 STEVE DENTON ROAD
 BARLOW, KY 42024
DETAILED SITE PLAN

ISSUED FOR:	
REVIEW	--
PERMIT	--
CONSTRUCTION	--
RECORD	--

PROJECT MANAGER	DESIGNER
TTP	DTC

JOB NO.
2017770.39

C-3

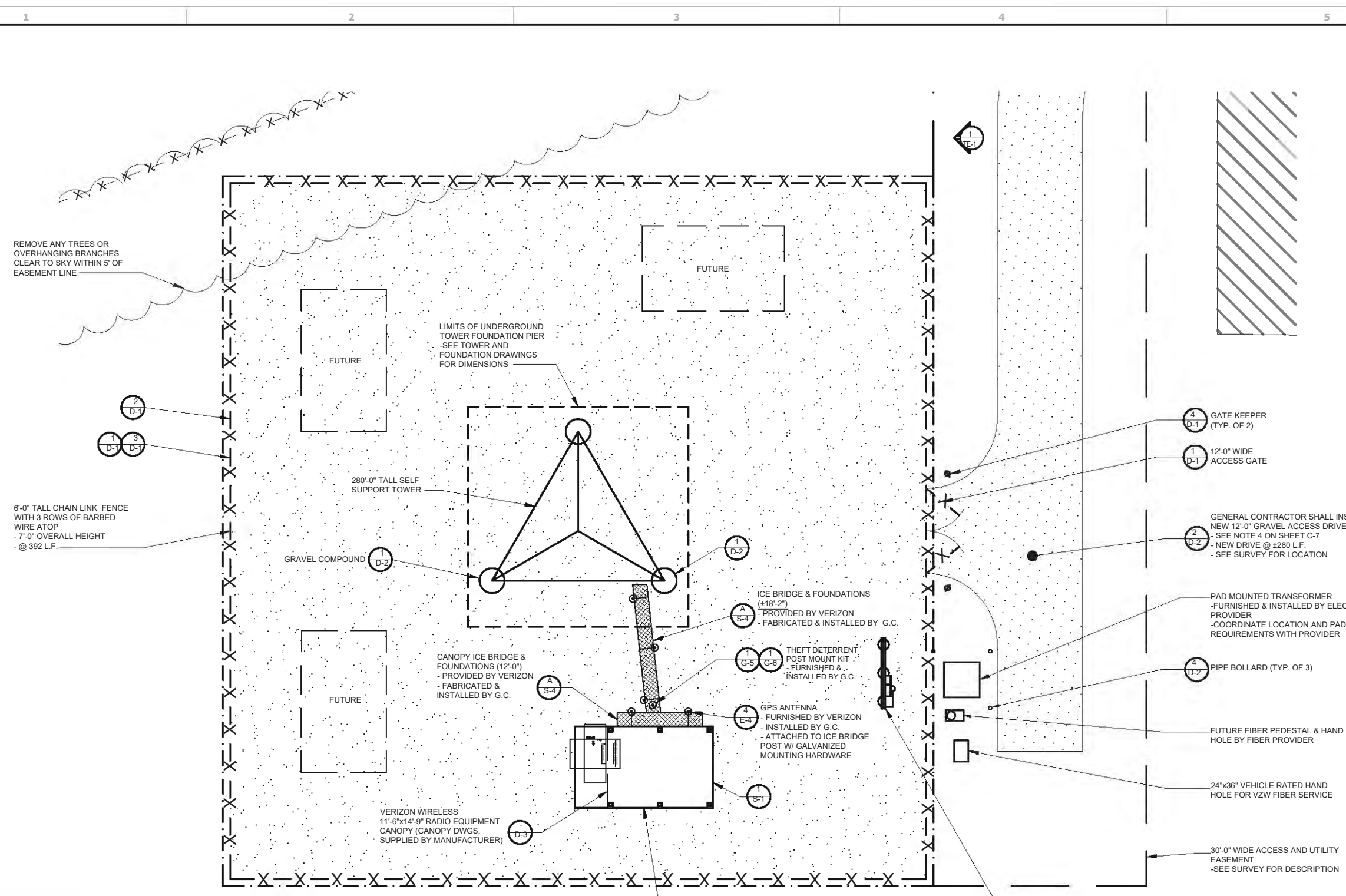

LEGEND

	IRON PIN
	DRAINAGE LINE
	SPOT ELEVATION
	GRAVEL COMPOUND
	CENTER LINE
	NEW FENCE LINE
	NEW SILT FENCE LINE
	POWER POLE/W/OVERHEAD ELEC./TELE.
	EDGE OF NEW DRIVE
	UNDERGROUND ELECTRICAL CONDUIT
	UNDERGROUND TELEPHONE CONDUIT
	EXISTING CONTOURS
	NEW CONTOURS
	FENCED COMPOUND
	CONCRETE
	ACCESS DRIVE

DETAILED SITE PLAN
 SCALE: 1/16" = 1'-0"

*NOTE:
 GENERAL CONTRACTOR IS TO INSURE
 THERE IS NO DISTURBANCE OF
 PROPERTY, SOIL, ETC. OUTSIDE OF THE
 STAKED LEASE AREA WITHOUT
 APPROVAL FROM VERIZON WIRELESS
 CONSTRUCTION MANAGER

Kentucky 811
 Know what's below.
 Call before you dig.
 1-800-752-6007
 PER KENTUCKY STATE LAW, IT IS AGAINST THE LAW
 TO EXCAVATE WITHOUT NOTIFYING THE
 UNDERGROUND LOCATION SERVICE TWO (2)
 WORKING DAYS BEFORE COMMENCING WORK

Drawing Name: O:\2017\201777039\EV Barlow\AEC\DEV Barlow CD.dwg
 February 8, 2019 2:6 PM - skrschneer

KENTUCKY RSA No. 1 PARTNERSHIP
 d/b/a VERIZON WIRELESS

 INDICAPULUIS, ILLINOIS 62424-4624

REVISION	DATE	DESCRIPTION
A	10/2/18	REVISED FOR 90% REVIEW
B	07/17/19	REVISED DISTANCE TO HOUSE
C	02/08/19	REVISED BUILDING CALLOUTS AND REVISED SHEET TITLE
D	02/08/19	REVISED CONSTRUCTION DRAWINGS



EV BARLOW
 2557 STEVE DENTON ROAD
 BARLOW, KY 42024

**DIMENSIONED
 SITE PLAN**

ISSUED FOR:	
REVIEW	--
PERMIT	--
CONSTRUCTION	--
RECORD	--

PROJECT MANAGER	DESIGNER
TTP	DTC

JOB NO.
2017770.39

C-4

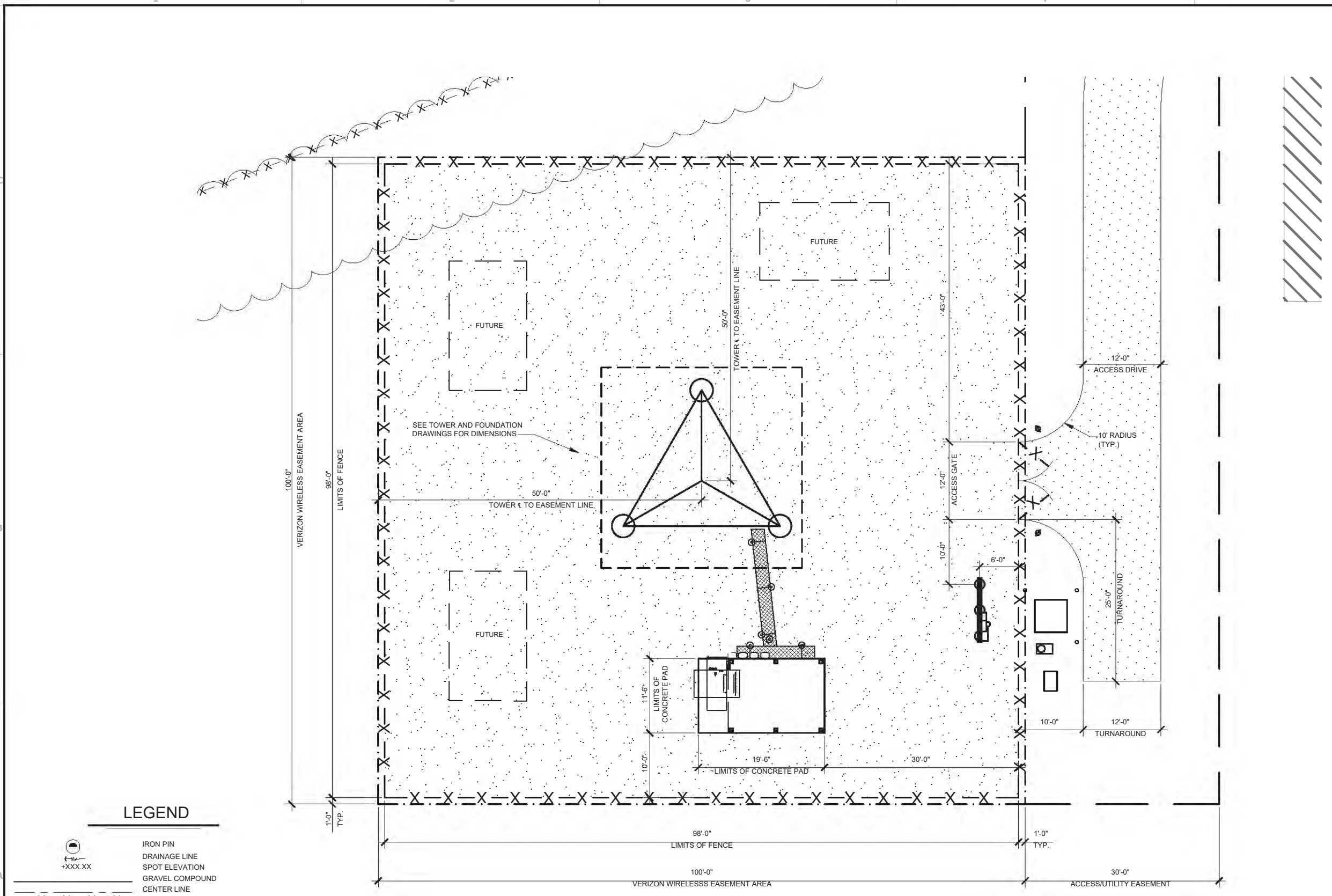

- LEGEND**
- IRON PIN
 - DRAINAGE LINE
 - SPOT ELEVATION
 - GRAVEL COMPOUND
 - CENTER LINE
 - NEW FENCE LINE
 - NEW SILT FENCE LINE
 - POWER POLE/OVERHEAD ELEC./TELE.
 - EDGE OF NEW DRIVE
 - UNDERGROUND ELECTRICAL CONDUIT
 - UNDERGROUND TELEPHONE CONDUIT
 - EXISTING CONTOURS
 - NEW CONTOURS
 - FENCED COMPOUND
 - CONCRETE
 - ACCESS DRIVE

DIMENSIONED SITE PLAN
 SCALE: 1/16" = 1'-0"



*NOTE:
 GENERAL CONTRACTOR IS TO ENSURE
 THERE IS NO DISTURBANCE OF
 PROPERTY, SOIL, ETC. OUTSIDE OF THE
 STAKED LEASE AREA WITHOUT
 APPROVAL FROM VERIZON WIRELESS
 CONSTRUCTION MANAGER

Kentucky 811
 Know what's below.
 Call before you dig.
 1-800-752-6007
 PER KENTUCKY STATE LAW, IT IS AGAINST THE LAW
 TO EXCAVATE WITHOUT NOTIFYING THE
 UNDERGROUND LOCATION SERVICE TWO (2)
 WORKING DAYS BEFORE COMMENCING WORK.

Drawing Name: O:\2017\20177039\EV Barlow\AEC\DEV Barlow CD.dwg
 February 8, 2019 2:7 PM - skrschneer

KENTUCKY RSA No. 1 PARTNERSHIP
 d/b/a Verizon Wireless

 1000 W. MARKET, SUITE 40240
 INDIANAPOLIS, IN 46240

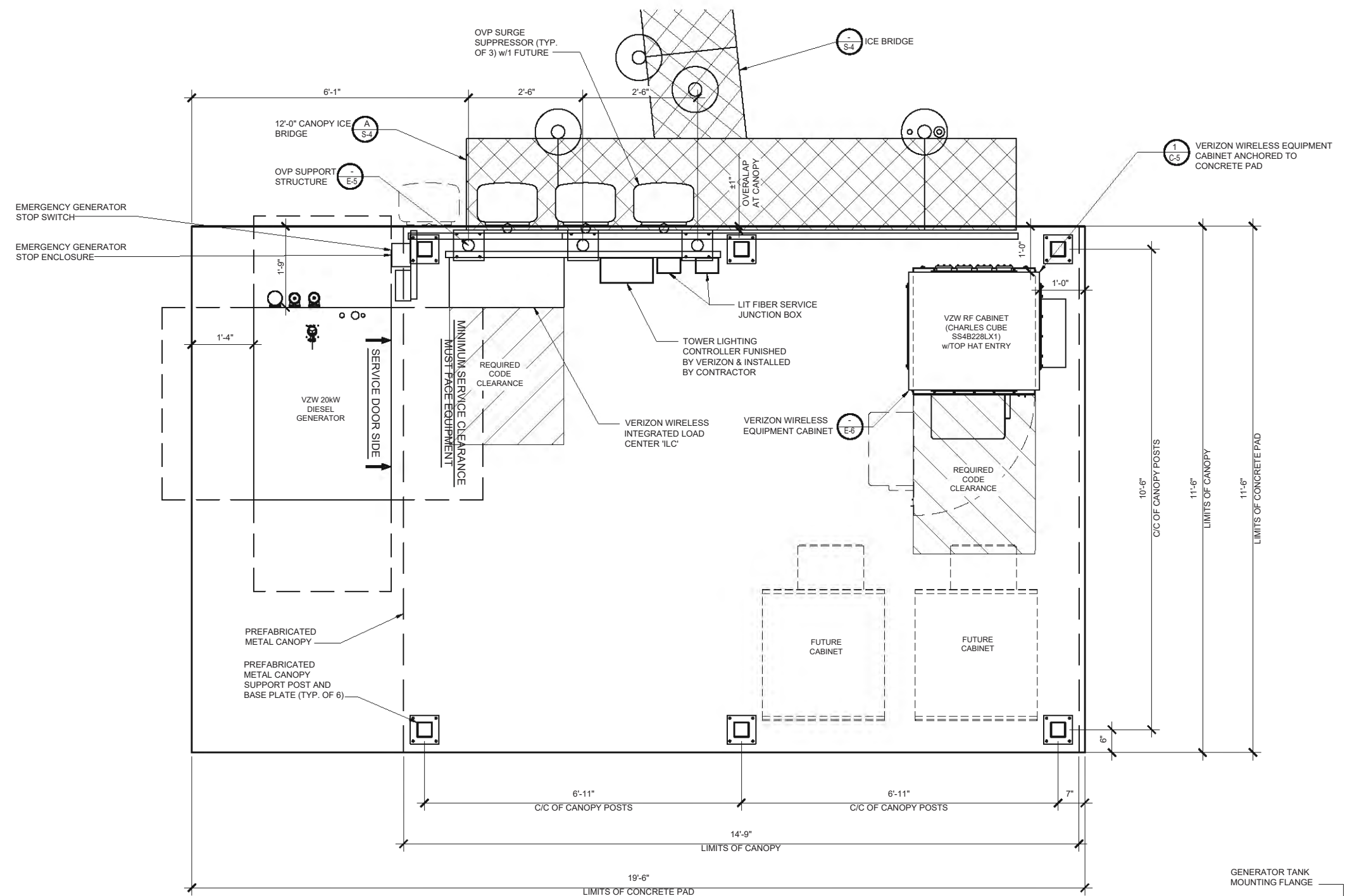

STATE OF KENTUCKY
LEONARDO SFERRA
 31562
 LICENSED PROFESSIONAL ENGINEER
 CIVIL SEAL 02/08/19

EV BARLOW
 2557 STEVE DENTON ROAD
 BARLOW, KY 42024
DETAILED EQUIPMENT PAD PLAN

ISSUED FOR:	
REVIEW	--
PERMIT	--
CONSTRUCTION	--
RECORD	--
PROJECT MANAGER	DESIGNER
TTP	DTC

JOB NO.
2017770.39
C-5

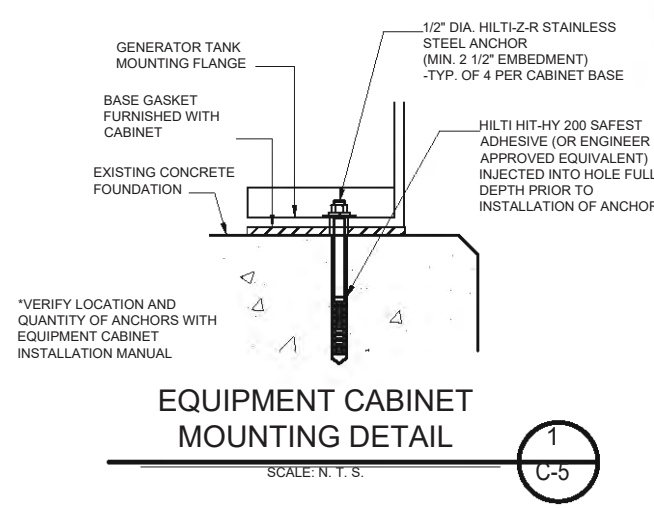

EROSION & SEDIMENT CONTROL NOTES

- ALL WORK SPECIFIED AS AIAN DOT ITEM SHALL BE GOVERNED BY THE STATE OF INDIANA OF DEPARTMENT OF TRANSPORTATION CONSTRUCTION AND MATERIAL SPECIFICATION HANDBOOK. IT IS CONTRACTORS RESPONSIBILITY TO POSSESS AND BE FAMILIAR WITH APPLICABLE SECTIONS.
- THIS CONTRACT DRAWING SHALL BE MADE AVAILABLE ON SITE AT ALL TIMES AND PRESENTED UPON REQUEST. IF UNFORESEEN STORM WATER POLLUTION PREVENTION IS ENCOUNTERED, ADDITIONAL STORM WATER POLLUTION PREVENTION (SWPP) MEASURES MAY BE REQUESTED BY THE OWNER, COUNTY ENGINEER, PROJECT ENGINEER OR SOIL CONSERVATION SERVICE REPRESENTATIVE AT ANYTIME. SUCH REQUESTS SHALL BE IMPLEMENTED IMMEDIATELY AT CONTRACTOR'S EXPENSE.
- ALL STORM WATER POLLUTION PREVENTION ITEMS SHALL BE INSTALLED AS SHOWN OR NOTED ON THIS SHEET.
- PLANT TEMPORARY SEEDING AND MULCHING IN ALL AREAS THAT SHALL BE INACTIVE FOR 7 DAYS OR MORE. ALL DISTURBED AND ERODED EARTH SHALL BE REGRADED AND SEEDED WITHIN 14 DAYS WITH SEEDING, AS DEFINED ABOVE AND AS SHOWN ON THE TABLE BELOW. TO ESTABLISH STABILITY AND PROVIDE SEDIMENT CONTROL, WHERE POSSIBLE. TEMPORARY SEEDING GROWTH SHALL NOT BE MOWED UNTIL IT HAS GONE TO SEED FOR 1 YEAR.

	JAN.	FEB.	MAR.	APR.	MAY	JUN.	JUL.	AUG.	SEP.	OCT.	NOV.	DEC.
PERMANENT SEEDINGS			A									
DORMANT SEEDINGS	B									B		
TEMPORARY SEEDINGS			C		D							
SODDING			E**									
MULCHING	F											

- A. KENTUCKY BLUEGRASS 90 LBS./AC/MIXED PERENNIAL RYEGRASS 30 LBS./ACRE
- B. KENTUCKY BLUEGRASS 135 LBS./AC/MIXED PERENNIAL RYEGRASS 45 LBS./AC. 2 TON STRAW MULCH PER ACRE
- C. SPRING OATS 100 LBS./ACRE
- D. WHEAT OR CEREAL RYE 150 LBS./ACRE
- E. SOD (NURSERY CROWN KENTUCKY BLUEGRASS) 150 LBS./ACRE
- F. STRAW MULCH 2 TONS PER ACRE
- * IRRIGATION NEEDED DURING JUNE, JULY & SEPTEMBER
- ** IRRIGATION NEEDED FOR 2-3 WEEKS AFTER SODDING

- PERMANENT VEGETATION SHALL BE INSTALLED WITHIN 10 DAYS AT THE COMPLETION OF ANY GRADED AREAS, WEATHER PERMITTING. ALL PERMANENT VEGETATION SHALL CONSIST OF PLANTING AND SOD
- AT SUCH TIME ROUGH GRADING OF THE SITE IS COMPLETE AND DRAINAGE DIVERTS TO INLETS, INLET SEDIMENT FILTERS SHALL BE INSTALLED AT ALL INLET STRUCTURES TO KEEP PIPING SYSTEMS FREE OF SILTATION.
- SILT BARRIERS SHALL BE INSTALLED AROUND ALL EXISTING OR NEW STORM INLETS, CATCH BASINS AND YARD DRAINS. INSTALL ROCK CHECK DAMS FOR HEADWALL INLETS FOR STORM WATER POLLUTION PREVENTION.
- STORM WATER POLLUTION PREVENTION MEASURES SHALL BE INSTALLED OR TOPSOIL STOCKPILES AND OTHER TEMPORARILY DISTURBED AREAS AS SHOWN ON THESE PLANS AND AS DIRECTED BY THE ENGINEER.
- CONTRACTOR SHALL INSPECT ALL SWPP MEASURES DAILY AND REPAIR AS NECESSARY TO PREVENT EROSION. SILTATION SHALL BE REMOVED FROM AREAS WHERE FAILURES HAVE OCCURRED AND CORRECTIVE ACTION TAKEN WITHIN 24 HOURS TO MAINTAIN ALL SWPP.
- SILT BARRIERS, CONSTRUCTION ENTRANCES, AND SILT FENCES SHALL REMAIN IN PLACE UNTIL A GOOD STAND OF GRASS HAS BEEN OBTAINED AND/OR PAVING OPERATIONS ARE COMPLETE. CONTRACTOR SHALL KEEP SILT FROM ENTERING ANY STORM DRAINAGE SYSTEM. ONCE SITE HAS BEEN COMPLETELY STABILIZED, ANY SILT IN PIPES AND DRAINAGE SWALES SHALL BE REMOVED WITHIN 10 DAYS.
- TEMPORARY SEDIMENTATION AND STORM WATER POLLUTION PREVENTION MEASURES MUST BE INSPECTED AND LOGGED BY THE CONTRACTOR FOR INSPECTION, LOGGING SHALL BE WEEKLY AND AFTER RAIN STORMS.
- UTILITY COMPANIES MUST COMPLY WITH ALL STORM WATER POLLUTION PREVENTION MEASURES AS DEFINED ON THE STORM WATER PREVENTION PLANS, DETAILS AND NOTES.
- THE TOTAL AREA OF DISTURBANCE FOR THIS PROJECT IS APPROXIMATELY 0.96 ACRES.
- ALL EXISTING WATER COURSES WITHIN THE PROJECT LIMITS SHALL BE TEMPORARILY PROTECTED DURING LAND CLEARING AND GRADING OPERATIONS. SOILS WITHIN 50 FEET OF SAID WATER COURSES SHALL BE STABILIZED WITHIN 2 DAYS OF THE INITIAL CLEARING / GRADING OPERATION AS SHOWN ON PLANS.
- ALL DISTURBED AREAS SHALL BE STABILIZED WITHIN 7 DAYS OF FINAL GRADING.
- IT IS THE CONTRACTOR'S RESPONSIBILITY TO MAINTAIN ALL SEDIMENTATION AND STORM WATER POLLUTION PREVENTION ITEMS AT ALL TIMES.
- ALL STORM WATER POLLUTION PREVENTION PRACTICES WILL BE INSTALLED BEFORE ANY OTHER EARTH MOVING OCCURS.
- THE FOLLOWING STORM WATER POLLUTION PREVENTION AND SEDIMENT CONTROL MEASURES WILL BE USED ON THIS SITE:
 - SILT BARRIERS
 - SILT FENCE
 - CONSTRUCTION ENTRANCE
 - EROSION CONTROL SEED BLANKETS - SPEC FOR TEMPORARY EROSION CONTROL BLANKETS ON SLOPES/DITCHES

CONSTRUCTION SEQUENCE

- STAKE AND/OR FLAG LIMITS OF CLEARING
- DURING PRECONSTRUCTION MEETING ALL EROSION & SEDIMENT CONTROL FACILITIES & PROCEDURES SHALL BE DISCUSSED
- CLEARING & GRUBBING, AS NECESSARY, FOR INSTALLATION OF PERIMETER CONTROLS.
- INSTALL SILT FENCE PERIMETER CONTROLS AS SHOWN ON PLANS.
- INSTALL CONSTRUCTION ENTRANCE, IF CONDITIONS ARE SUCH THAT MUD IS COLLECTION ON VEHICLE TIRES, THE TIRES MUST BE CLEANED BEFORE THE VEHICLES ENTER THE PUBLIC ROADWAY. THE SITE ENTRANCE SHALL BE MAINTAINED IN A CONDITION THAT WILL PREVENT THE TRACKING OR FLOW OF MUD INTO THE PUBLIC RIGHT-OF-WAY. ALL MATERIALS SPILLED, DROPPED, WASHED OR TRACKED FROM VEHICLES ONTO THE ROADWAY MUST BE REMOVED PROMPTLY.
- CLEARING & GRUBBING THE REMAINING SITE AS NECESSARY.
- BEGIN FILLING & GRADING AS REQUIRED TO REACH SUBGRADE.
- CONSTRUCT AND MAINTAIN TEMPORARY DRAINAGE SWALES DURING FILLING AND GRADING ACTIVITIES.
- CONSTRUCT SITE WORK INCLUDING STORM DRAINAGE FACILITIES.
- MAINTAIN EROSION & SEDIMENTATION CONTROL MEASURES UNTIL THE SITE HAS BEEN COMPLETELY STABILIZED.
- REMOVE SEDIMENT CONTROLS.

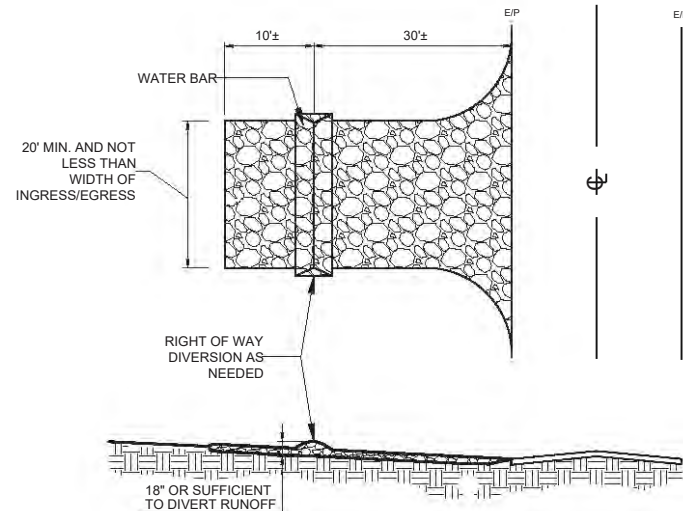

NOTES:

- STONE SIZE - TWO INCH STONE SHALL BE USED, OR RECYCLED CONCRETE EQUIVALENT.
- THE CONSTRUCTION ENTRANCE SHALL COINCIDE WITH THE PROPOSED DRIVE AS SHOWN ON THE PLAN.
- PAVEMENT THICKNESS - STONE LAYER SHALL BE AT LEAST 6" THICK. DRIVEWAY WIDTH - THE ENTRANCE SHALL BE AT LEAST 10' WIDE, BUT NOT LESS THAN FULL WIDTH AT POINTS WHERE INGRESS/EGRESS OCCURS.
- BEDDING - A GEOTEXTILE SHALL BE PLACED OVER THE ENTIRE AREA PRIOR TO PLACING STONE. IT SHALL HAVE A GRAB TENSILE STRENGTH OF AT LEAST 200 LBS. AND A MULLEN BURST STRENGTH OF AT LEAST 190 LBS.
- CULVERT - A PIPE OR CULVERT SHALL BE CONSTRUCTED UNDER THE ENTRANCE IF NEEDED TO PREVENT SURFACE WATER FLOWING ACROSS THE ENTRANCE FROM BEING DIRECTED OUT ONTO PAVED SURFACES.
- WATER BAR - A WATER BAR SHALL BE CONSTRUCTED AS PART OF THE CONSTRUCTION ENTRANCE IF NEEDED TO PREVENT SURFACE RUNOFF FROM FLOWING THE LENGTH OF THE CONSTRUCTION ENTRANCE AND OUT ONTO PAVED SURFACES.
- MAINTENANCE - TOP DRESSING OF ADDITIONAL STONE SHALL BE APPLIED AS CONDITIONS DEMAND, MUD SPILLED, DROPPED, WASHED OR TRACKED ONTO PUBLIC ROADS, OR ANY SURFACE WHERE RUNOFF IS NOT CHECKED BY SEDIMENT CONTROLS, SHALL BE REMOVED IMMEDIATELY. REMOVAL SHALL BE ACCOMPLISHED BY SCRAPING OR SWEEPING.
- CONSTRUCTIONS ENTRANCES SHALL NOT BE RELIED UPON TO REMOVE MUD FROM VEHICLES AND PREVENT OFF SITE TRACKING. VEHICLES THAT ENTER AND LEAVE THE CONSTRUCTION SHALL BE RESTRICTED FROM MUDDY AREAS.

TEMPORARY STABILIZED CONSTRUCTION ENTRANCE

SCALE: N.T.S.

1
C-7

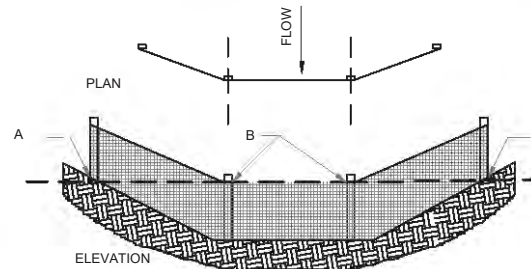
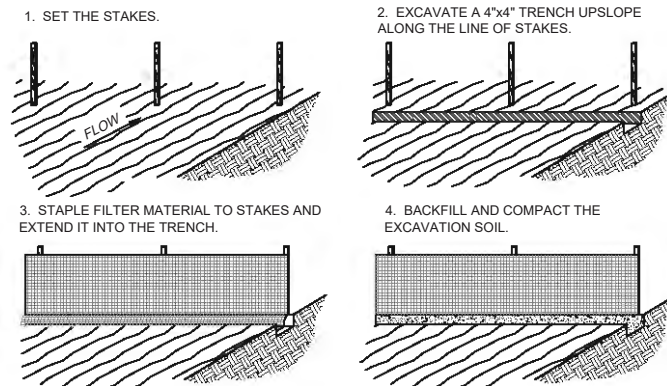

SILT FENCE DETAIL

SCALE: N.T.S.

2
C-7

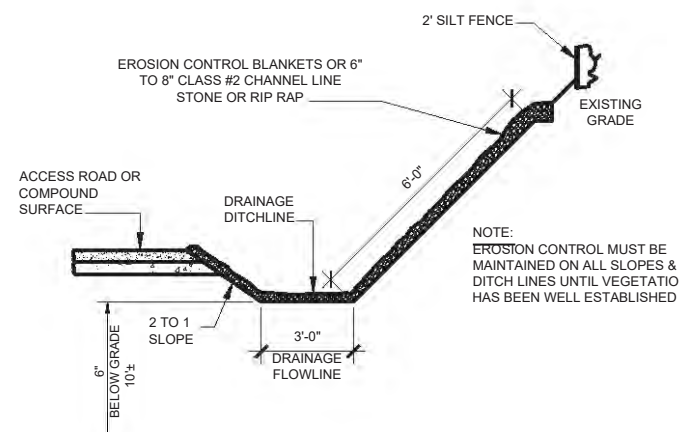

NOTES:

- WHEN FACED WITH SLOPES LESS THAN 2 TO 1 SLOPES, ALL SLOPES SHOULD BE DOZER TRACKED PRIOR TO SEEDING. ALL SLOPES SHOULD HAVE EROSION CONTROL BLANKETS OR RIP RAP EMBEDDED ON SLOPES SURFACES TO REDUCE EROSION.
- ALL FLOWLINES MUST BE INSTALLED BELOW SUB-GRADE OF COMPOUND, (AT MINIMUM OF 6" BELOW)

DRAINAGE DITCHLINE DETAIL (SWALE)

SCALE: N.T.S.

3
C-7

GPD GROUP, INC.
520 South Main Street, Suite 2531
Akron, OH 44311
330.572.2100 Fax: 330.572.2102

KENTUCKY RSA No. 1 PARTNERSHIP
d/b/a VERIZON WIRELESS
INDIANAPOLIS, INDIANA 46240



EV BARLOW
2557 STEVE DENTON ROAD
BARLOW, KY 42024

BEST MANAGEMENT PRACTICES & EROSION CONTROL DETAILS & NOTES

ISSUED FOR:	
REVIEW	--
PERMIT	--
CONSTRUCTION	--
RECORD	--

PROJECT MANAGER	DESIGNER
TTP	DTC

JOB NO.
2017770.39

C-7

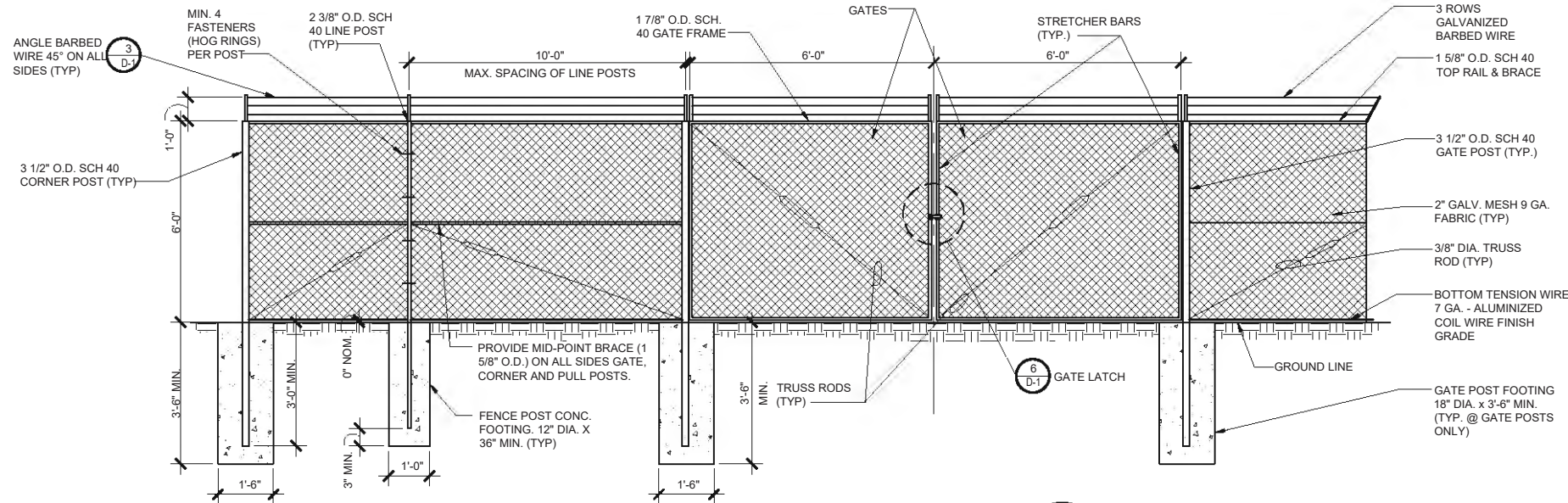

CHAIN LINK FENCE & POST DETAIL (1) D-1
SCALE: N.T.S.

- ### CHAIN LINK FENCING NOTES
- ALL FENCE AND FABRIC SHALL BE HOT DIPPED GALVANIZED WITH A MINIMUM OF 2 OZ. PER SQUARE FOOT, 9 GAUGE WIRE (MIN. BREAKING STRENGTH OF 1,290 LBS) WITH 2" MESH. ALL BARBED WIRE SHALL BE ALUMINUM OR COATED PER NOTE #4.
 - BOTTOM EDGE OF FENCE FABRIC SHALL EXTEND TO FINISHED GRADE.
 - SITE FENCE SHALL BE 6'-0" FABRIC W/ 3 STRAND BARBED WIRE FOR TOTAL HEIGHT OF 7'-0".
 - BARBED WIRE SHALL MEET ASTM A 121, CLASS 3 GALV. OR ASTM A 585, TYPE 1, CLASS 2 COATING (NOT LESS THAN 0.8 OZ. PER SQ. FT.) AND SHALL BE THREE STRAND 12.5 GAGE W/4 POINT BARBS AT 5" O/C.
 - BOTTOM OF CONCRETE BASE SHALL BE SET BELOW FROSTLINE (SEE LOCAL CODE). WHERE SOIL BEARING CAPACITY IS LESS THAN 2000 PSF, INCREASE CONCRETE SURROUNDING FENCE POST FOUNDATION DIAMETERS BY 8", PROVIDE CONCRETE WITH A 28 DAY STRENGTH OF 3000 PSI (MIN.)
 - PROVIDE A DIAGONAL BRACE ROD AND TURN BUCKLE ON BOTH GATE LEAFS.
 - ALL RAILS AND BRACES SHALL BE SCHEDULE 40 STEEL PIPE, AND ALL FENCE POSTS SHALL BE SCHEDULE 40 STEEL PIPE, AND BE 2 OZ. GALVANIZED COATED.
 - CONTRACTOR SHALL ENSURE ALL POSTS ARE PLUMB.
 - ALL FENCE SHALL BE FABRICATED AND INSTALLED PER ASTM F2611-15, ASTM F567-14a AND CHAIN LINK FENCE MANUFACTURES INSTITUTE CLFMI-PM 2445.
 - CONTRACTOR SHALL FURNISH AND INSTALL ONE (1) MASTER LOCK LONG SHANK #175LH COMBINATION PADLOCK. COMBINATION TO BE SET AT 7011.

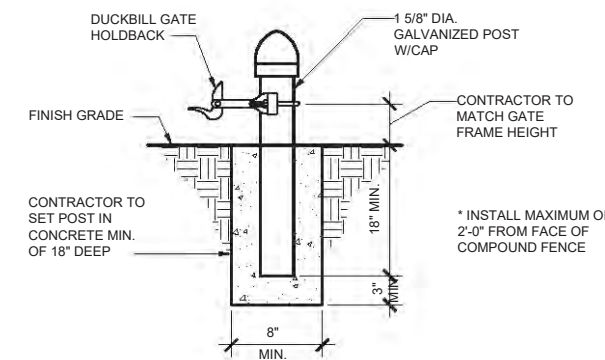

GATE KEEPER DETAIL (4) D-1
SCALE: N.T.S.

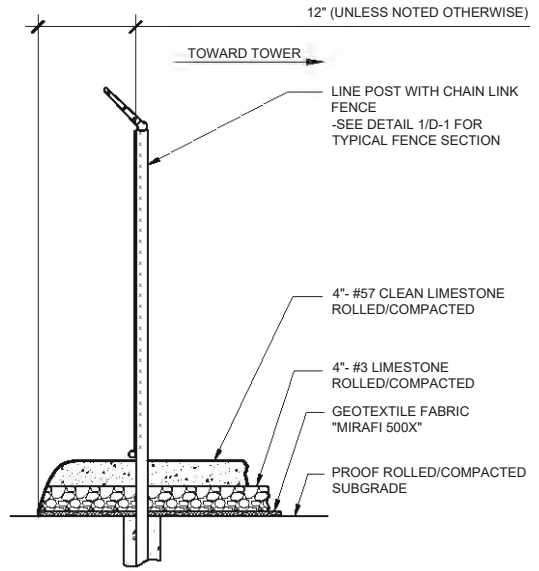

SITE AREA SURFACING (2) D-1
SCALE: N.T.S.

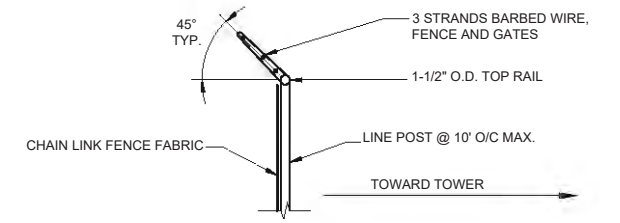

TYPICAL BARBED WIRE DETAIL (3) D-1
SCALE: N.T.S.

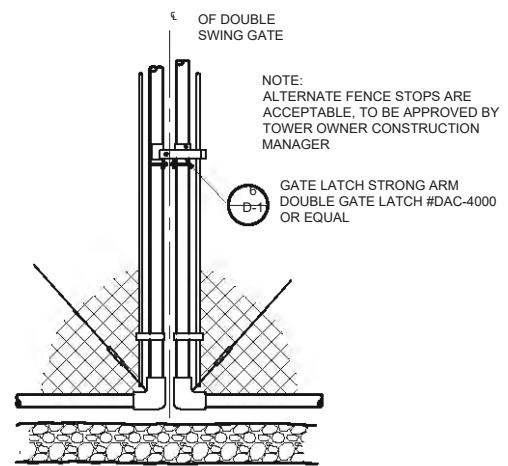

GATE LATCH DETAIL (5) D-1
SCALE: N.T.S.

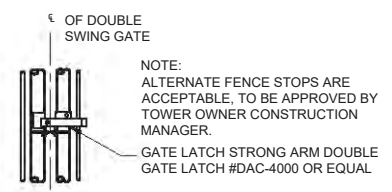

GATE LATCH DETAIL (6) D-1
SCALE: N.T.S.



GPD GROUP, INC.
520 South Main Street, Suite 2531
Akron, OH 44311
330.572.2100 Fax: 330.572.2102

KENTUCKY RSA No. 1 PARTNERSHIP
d/b/a Verizon Wireless
INDIANAPOLIS, INDIANA 46240

NO.	DESCRIPTION	DATE	BY
A	ISSUED FOR 90% REVIEW		
B	ISSUED FOR 100% REVIEW		
C	ISSUED FOR DISTANCE TO HOUSE		
D	ISSUED FOR BUILDING CALLS AND REVISIONS		
E	ISSUED FOR FINAL CONSTRUCTION DRAWINGS		

EV BARLOW
2557 STEVE DENTON ROAD
BARLOW, KY 42024

FENCE DETAILS AND NOTES

ISSUED FOR:	
REVIEW	--
PERMIT	--
CONSTRUCTION	--
RECORD	--

PROJECT MANAGER	DESIGNER
TTP	DTC

JOB NO.
2017770.39

D-1

KENTUCKY RSA No. 1 PARTNERSHIP
 d/b/a VERIZON WIRELESS
 VERIZON WIRELESS
 10000 W. WINDY HILL BLVD. SUITE 400
 INDIANAPOLIS, IN 46240

NO.	DESCRIPTION	DATE	BY
A	REVIEW FOR 90% REVIEW		
B	NOTED DISTANCE TO HOUSE		
C	REBUILDING CALLS AND REVISIONS		
D	FINAL CONSTRUCTION DRAWINGS		

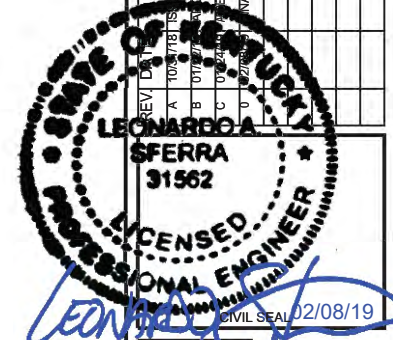

EV BARLOW
 2557 STEVE DENTON ROAD
 BARLOW, KY 42024

SITE DETAILS

ISSUED FOR:	
REVIEW	--
PERMIT	--
CONSTRUCTION	--
RECORD	--

PROJECT MANAGER	DESIGNER
TTP	DTC

JOB NO.
2017770.39

D-2

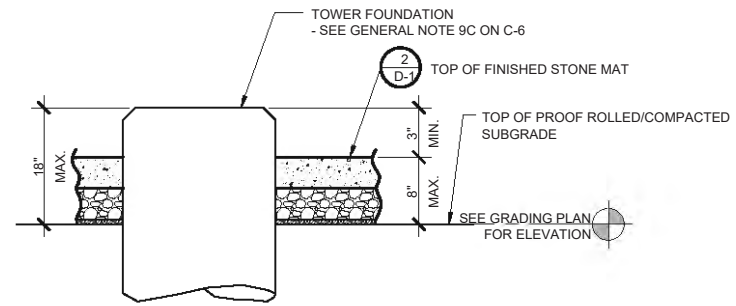

PARTIAL COMPOUND SECTION
 SCALE: N.T.S.

NOTE:
 1. CONTRACTOR SHALL PRIME & PAINT BOLLARDS OSHA YELLOW

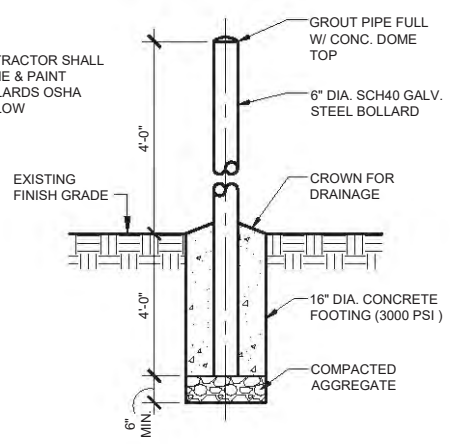

BOLLARD DETAIL
 SCALE: N.T.S.

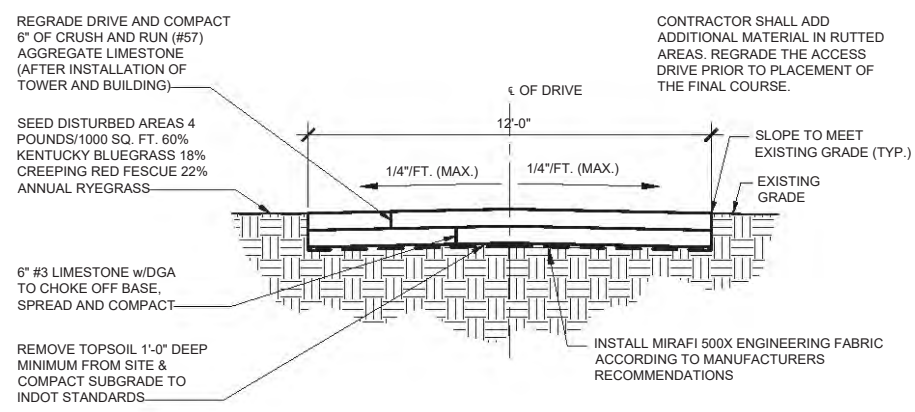

ACCESS DRIVE TYPICAL SECTION
 SCALE: N.T.S.

12'-0" GRAVEL ACCESS DRIVE
 - SEE NOTE 4 ON SHEET C-6
 - NEW DRIVE @ ±280 L.F.T.
 - SEE SURVEY FOR LOCATION

NEW UTILITY POLE PROVIDED & INSTALLED BY UTILITY CO.

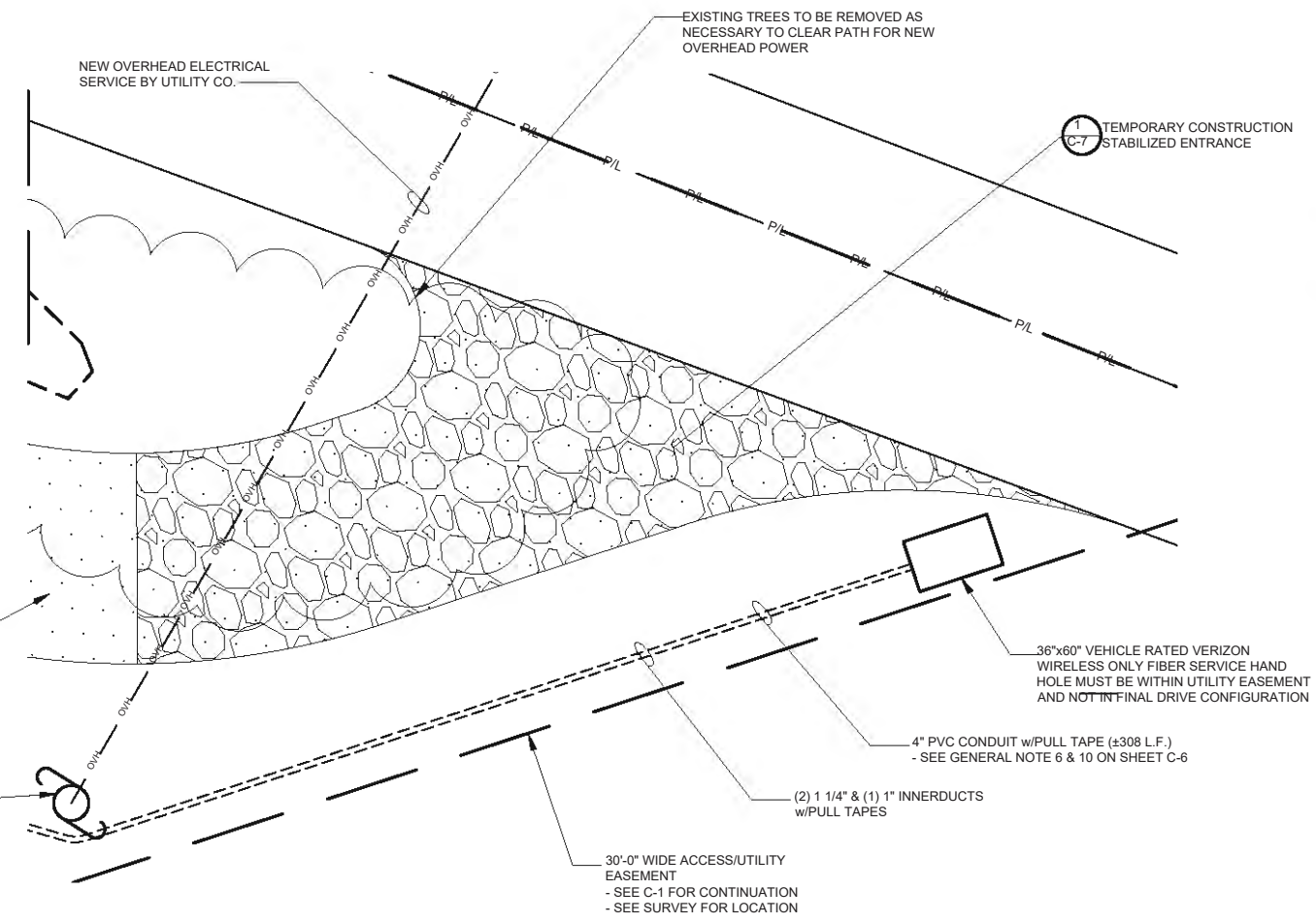

ENLARGED FIBER HAND HOLE PLAN AT R.O.W.
 SCALE: 3/32" = 1'-0"

5
D-2



1 2 3 4 5

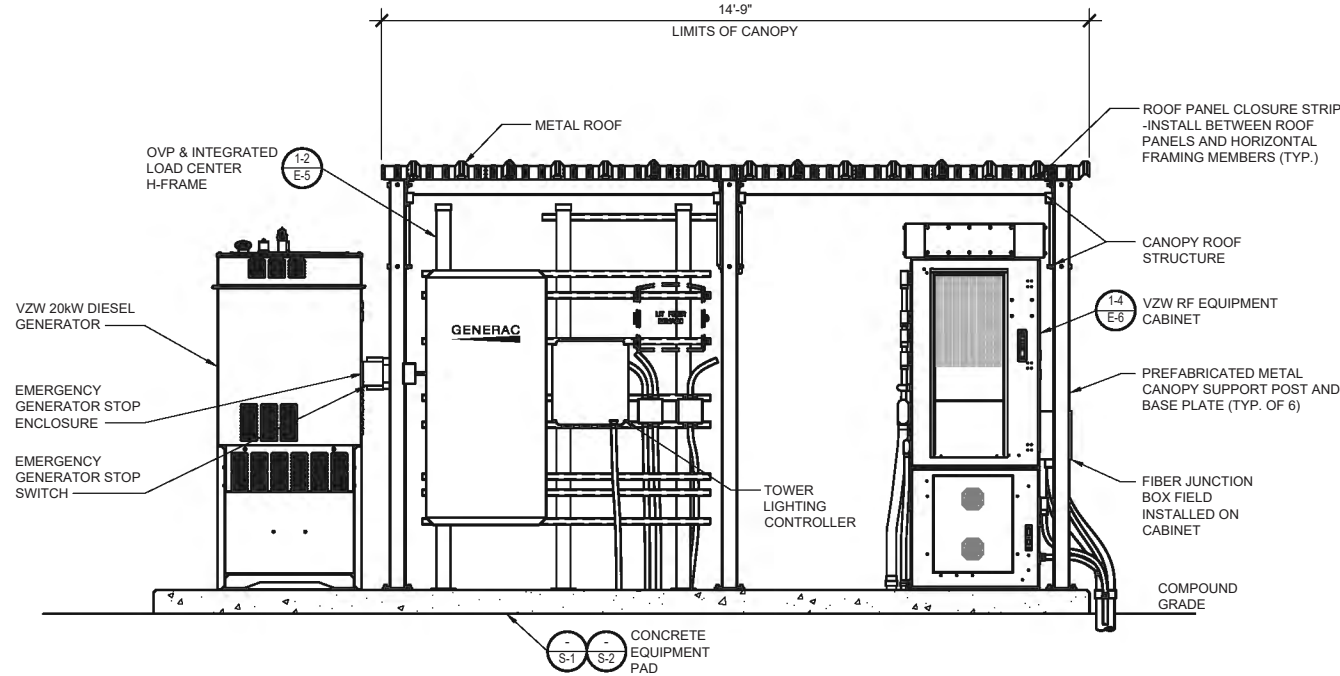

NOTE:
CANOPY ROOF PANELS PROFILE R/PBR. PROVIDE 1.7lb DENSITY POLYETHYLENE FOAM PANEL CLOSURE STRIPS TO MATCH PROFILE. AS MANUFACTURED BY: SEALTITE BUILDING FASTENERS "ST CLOSURE" STRIPS OR EQUAL (VERIFY PROFILE WITH ROOF PANELS SUPPLIED WITH CANOPY)

FRONT ELEVATION
SCALE: 1/4" = 1'-0"

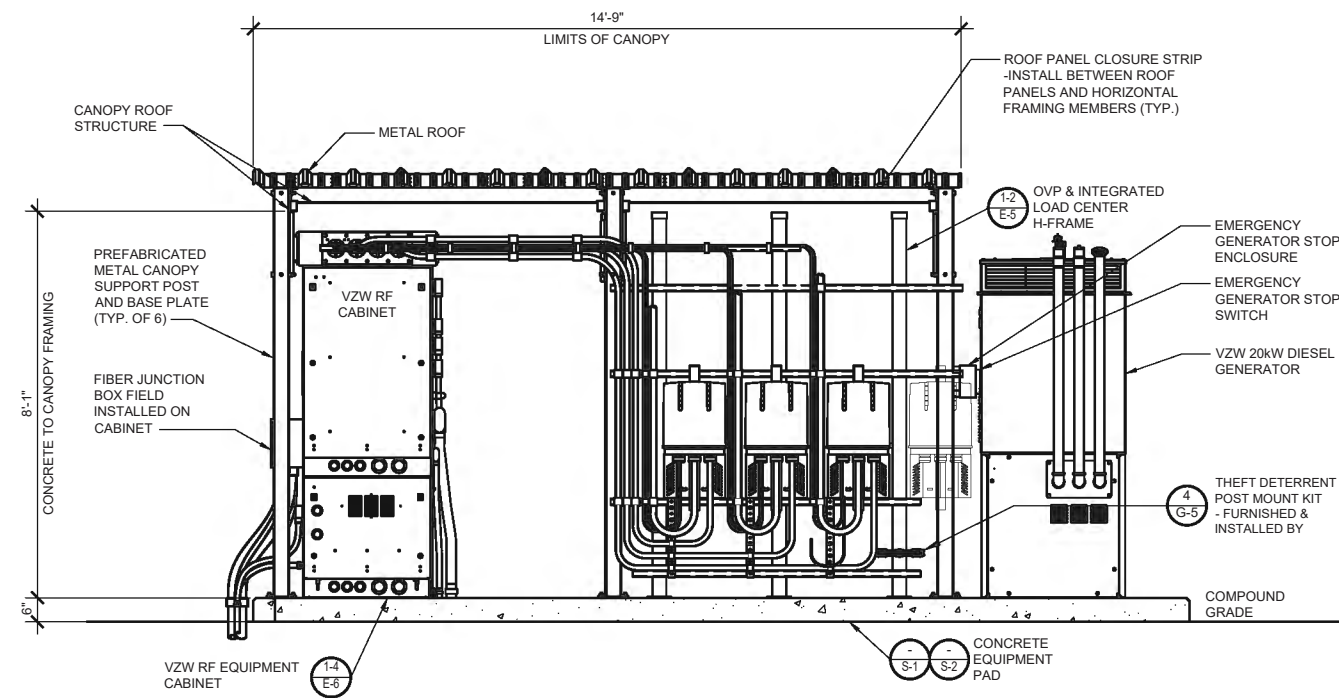

REAR ELEVATION
SCALE: 1/4" = 1'-0"

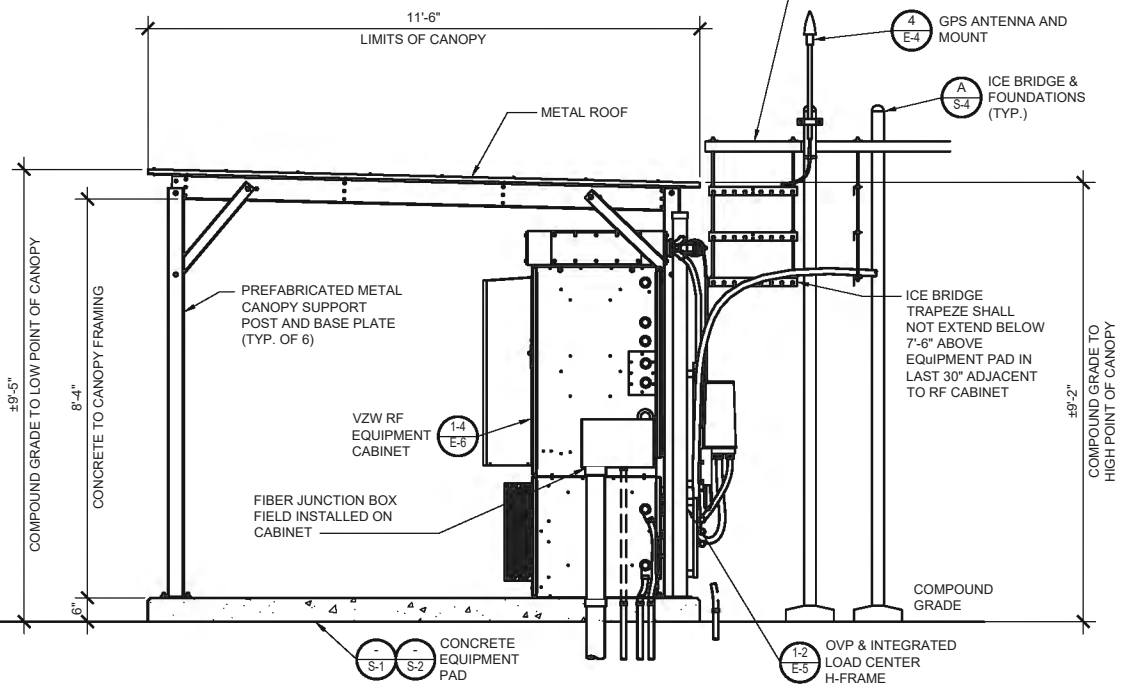

RIGHT ELEVATION
SCALE: 1/4" = 1'-0"

REV.	DATE	DESCRIPTION
A	10/31/18	ISSUED FOR 90% REVIEW
B	01/22/19	ADDED DISTANCE TO HOUSE
C	01/24/19	ADDED BUILDING CALL OUTS AND REVISED SHEET TITLE
D	02/08/19	FINAL CONSTRUCTION DRAWINGS

REFERENCE ONLY

EV BARLOW
2557 STEVE DENTON ROAD
BARLOW, KY 42024

CANOPY ELEVATIONS (REFERENCE ONLY)

ISSUED FOR:	
REVIEW	--
PERMIT	--
CONSTRUCTION	--
RECORD	--

PROJECT MANAGER	DESIGNER
TTP	DTC

JOB NO.
2017770.39

D-3

NOTES:

VERIZON WIRELESS SITE ID SIGN, RFE SIGNS, NOC INFORMATION SIGN AND ALL OTHER SIGNAGE NOT REFERENCED IN THIS DRAWING WILL BE FURNISHED AND INSTALLED BY VERIZON WIRELESS PERSONELL PER VERIZON WIRELESS RFC SIGNAGE & DEMARCATION POLICY.

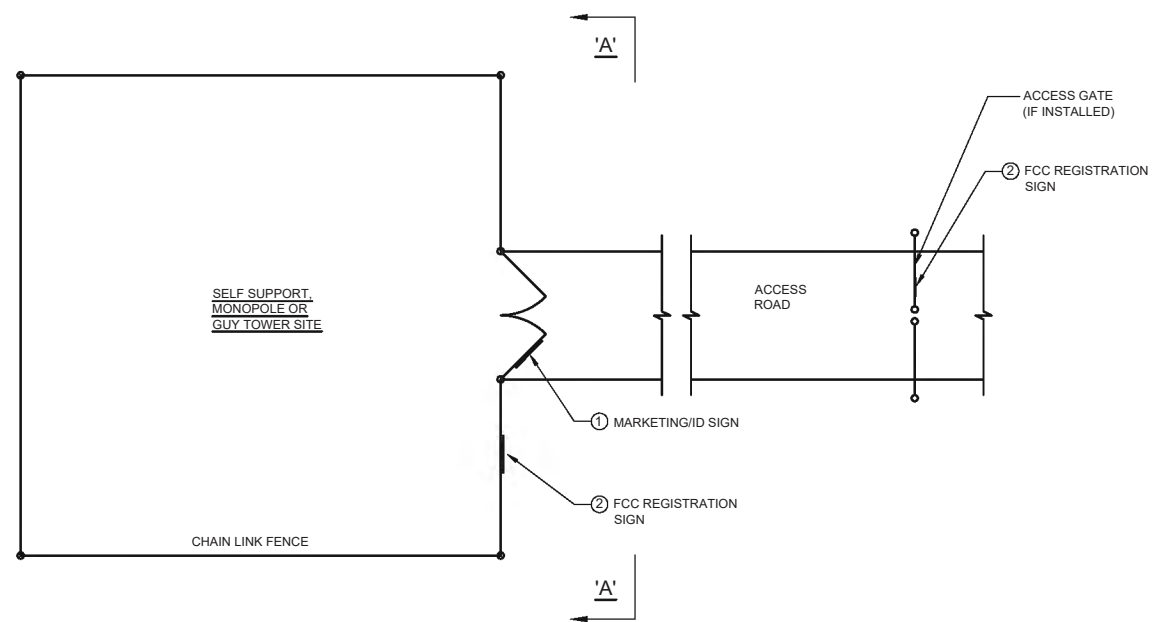

TYPICAL SITE FENCE SIGNAGE PLAN

SCALE: N. T. S.

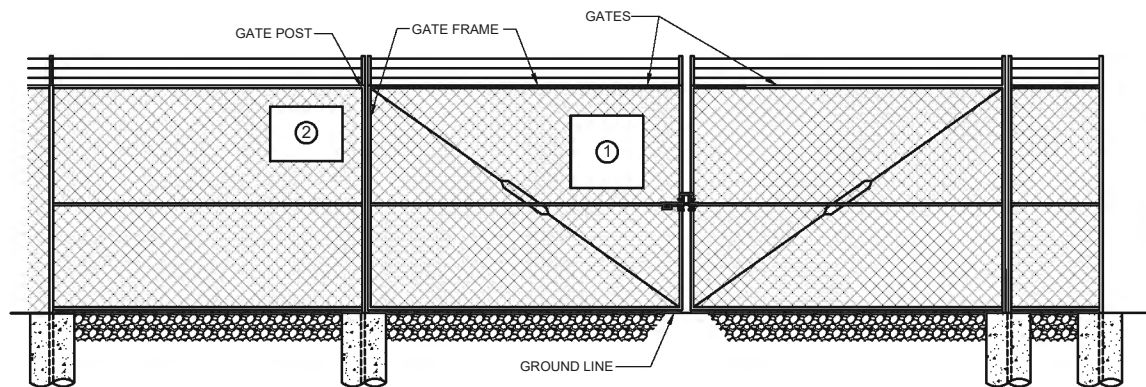

ELEVATION "A-A"

SCALE: N. T. S.

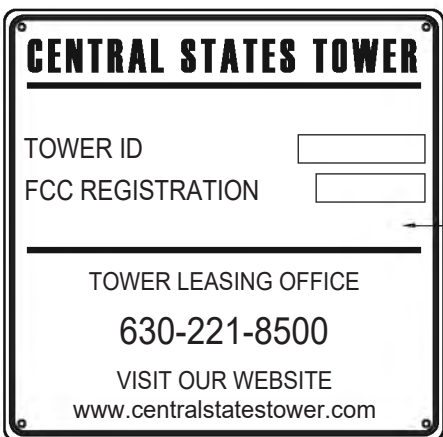

MARKETING/ID SIGN

24" WIDE x 24" HIGH

1

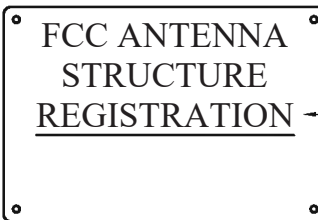

FCC REGISTRATION SIGN

24" WIDE x 18" HIGH

2

WHITE BACKGROUND
w/BLACK LETTERING

WHITE BACKGROUND
w/BLACK LETTERING

GPD GROUP, INC.
520 South Main Street, Suite 2531
Akron, OH 44311
330.572.2100 Fax: 330.572.2102

KENTUCKY RSA No. 1 PARTNERSHIP
verizon wireless
d/b/a VERIZON WIRELESS
250 E. 9TH STREET
INDIANAPOLIS, INDIANA 46340

REV.	DATE	DESCRIPTION
A	10/31/18	ISSUED FOR 90% REVIEW
B	01/22/19	ADDED DISTANCE TO HOUSE
C	01/24/19	ADDED BUILDING CALL OUTS AND REVISED SHEET TITLE
D	02/08/19	FINAL CONSTRUCTION DRAWINGS

REFERENCE ONLY

EV BARLOW
2557 STEVE DENTON ROAD
BARLOW, KY 42024
**SITE FENCE SIGNAGE
(REFERENCE ONLY)**

ISSUED FOR:	
REVIEW	--
PERMIT	--
CONSTRUCTION	--
RECORD	--

PROJECT MANAGER	DESIGNER
TTP	DTC

JOB NO.
2017770.39

D-4

Drawing Name: O:\2017\201777039\EV Barlow\AEC\DEV Barlow CD.dwg
February 8, 2019 2:7 PM - skrschner

STRUCTURAL NOTES

1. PLATFORM SYSTEM DESIGN LOADINGS:

ROOF SNOW LOAD	70 PSF
DEAD LOADS	ACTUAL MATERIAL WEIGHTS
BASIC WIND SPEED	120 MPH

DESIGN CODES

INTERNATIONAL BUILDING CODE (IBC) 2012
 MINIMUM DESIGN LOADS FOR BUILDINGS AND OTHER STRUCTURES ASCE7-10
 OSHA REGULATIONS

2. STRUCTURAL STEEL:

PIPE - ASTM A53 TYPE E OR S GRADE B, OR ASTM A501.
 STRUCTURE FINISH - AFTER FABRICATION ACCORDING TO ASTM A123.

3. BUILDING FOUNDATION SYSTEM:

THE SUBSURFACE REPORT WAS PROVIDED BY ALT & WITZIG ENGINEERING, INC., DATED AUGUST 30, 2018.

ALLOWABLE BEARING CAPACITY BLDG. FOOTINGS 2,000 PSF

ALL CONTRACTORS SHALL EXERCISE GREAT CARE DURING EXCAVATION. ALL CONTRACTORS SHALL PREDETERMINE UTILITY LOCATIONS AND NOTIFY THE ENGINEER IMMEDIATELY IF DEVIATION FROM PLANS EXIST.

THE SUBSURFACE REPORT IS NOT TO BE CONSIDERED AS A COMPLETE RECORD OF THE EXISTING CONDITIONS AT THE SITE. THE CONTRACTOR SHALL VERIFY ALL EXISTING SITE CONDITIONS, INCLUDING SUBSURFACE CONDITIONS. THE CONTRACTOR SHALL OBTAIN PERMISSION FROM THE OWNER PRIOR TO SITE ENTRY FOR THE PURPOSE OF CONDUCTING SOIL TESTING AND VERIFICATION OF EXISTING CONDITIONS.

FOUNDATION SUBGRADES SHALL BE HAND TRIMMED AND COMPACTED. ALL BACKFILL TO BE COMPACTED TO 95% MAXIMUM DRY DENSITY IN ACCORDANCE WITH ASTM D-1557.

4. CONCRETE WORK:

CONCRETE CYLINDERS SHALL BE TAKEN AND TESTED BY A QUALIFIED CONCRETE TESTING COMPANY. THE GENERAL CONTRACTOR SHALL PROVIDE ONE (1) CYLINDER SAMPLE TAKEN PER TRUCK OR FOUR (4) TOTAL FOR BUILDING FOUNDATION AND THE CONCRETE MUST MEET A 4" SLUMP. THE GENERAL CONTRACTOR SHALL PROVIDE THREE (3) COPIES OF TESTING RESULTS TO VERIZON WIRELESS AND TOWER OWNER CONSTRUCTION MANAGERS. FAILURE TO PROVIDE WRITTEN DOCUMENTATION WILL RESULT IN A DEDUCTION FROM THE CONTRACT. THE CONTRACTOR WILL BE HELD RESPONSIBLE FOR ANY ADDITIONAL COSTS IN TESTING DUE TO DELAYS BY THE GENERAL CONTRACTOR OR HIS SUBCONTRACTORS. USE AIR ENTRAINMENT IN EXTERIOR SLABS.

SPECIFICATIONS - LATEST EDITION OF ACI-318 AS ADOPTED BY THE STATE OF KENTUCKY
 - BLDG. FOUNDATION F_c = 4000 PSI @ 28 DAYS

MATERIALS - REINFORCING - ASTM A615, GRADE 60
 - ANCHOR BOLTS - ASTM F1554 A36

REINFORCING COVERS - FOOTINGS
 TOP 2"
 BOTTOM/SIDES 3"

REINFORCING EMBEDMENT AND LAP SPLICES (INCHES) FOR 4000 PSI CONCRETE

BAR SIZE	ANCHORAGE	SPLICE (OTHER)	ANCHORAGE (TOP)	SPLICE (TOP)
#4	12"	25"	25"	33"

CHAMFER TOP CORNERS OF ALL FOUNDATIONS (3/4")

5. BURIED CABLE LOCATIONS INFORMATION

CONTACT 48 HR. PRIOR TO DIGGING, GRADING, OR DRILLING 1-800-752-6007 OR 811

ADDITIONAL CONCRETE NOTES:

- ALL CONCRETE CONSTRUCTION SHALL CONFORM TO ACI'96, "STANDARD SPECIFICATION FOR STRUCTURAL CONCRETE" AND ACI 305, 306 AND 307 UNLESS NOTED OTHERWISE.
- ALL DETAILING, FABRICATION AND PLACING OF CONCRETE SHALL CONFORM TO ACI 318-11.
- ALL CONCRETE EXPOSED TO WEATHER SHALL CONTAIN 6% (±1%) AIR ENTRAINMENT.
- PROVIDE CORNER BARS AT ALL LOCATIONS WHERE REINFORCEMENT CHANGES DIRECTION.

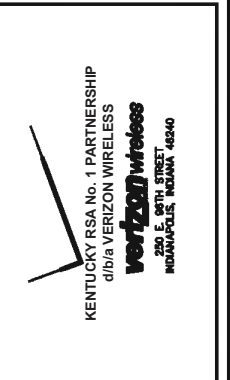

REV	DATE	DESCRIPTION
A	02/08/2019	ISSUED FOR 90% REVIEW
B	02/22/19	ADDED DISTANCE TO HOUSE
C	02/24/19	ADDED BUILDING CALL OUTS AND REVISED SHEET TITLE
D	02/24/19	FINAL CONSTRUCTION DRAWINGS

EV BARLOW
 2557 STEVE DENTON ROAD
 BARLOW, KY 42024
**FOUNDATION PLAN,
 DETAILS AND NOTES**

ISSUED FOR:	
REVIEW	---
PERMIT	---
CONSTRUCTION	---
RECORD	---

PROJECT MANAGER	DESIGNER
TTP	DTC

JOB NO.
2017770.39

S-1



PER KENTUCKY STATE LAW, IT IS AGAINST THE LAW TO EXCAVATE WITHOUT NOTIFYING THE UNDERGROUND LOCATION SERVICE TWO (2) WORKING DAYS BEFORE COMMENCING WORK.

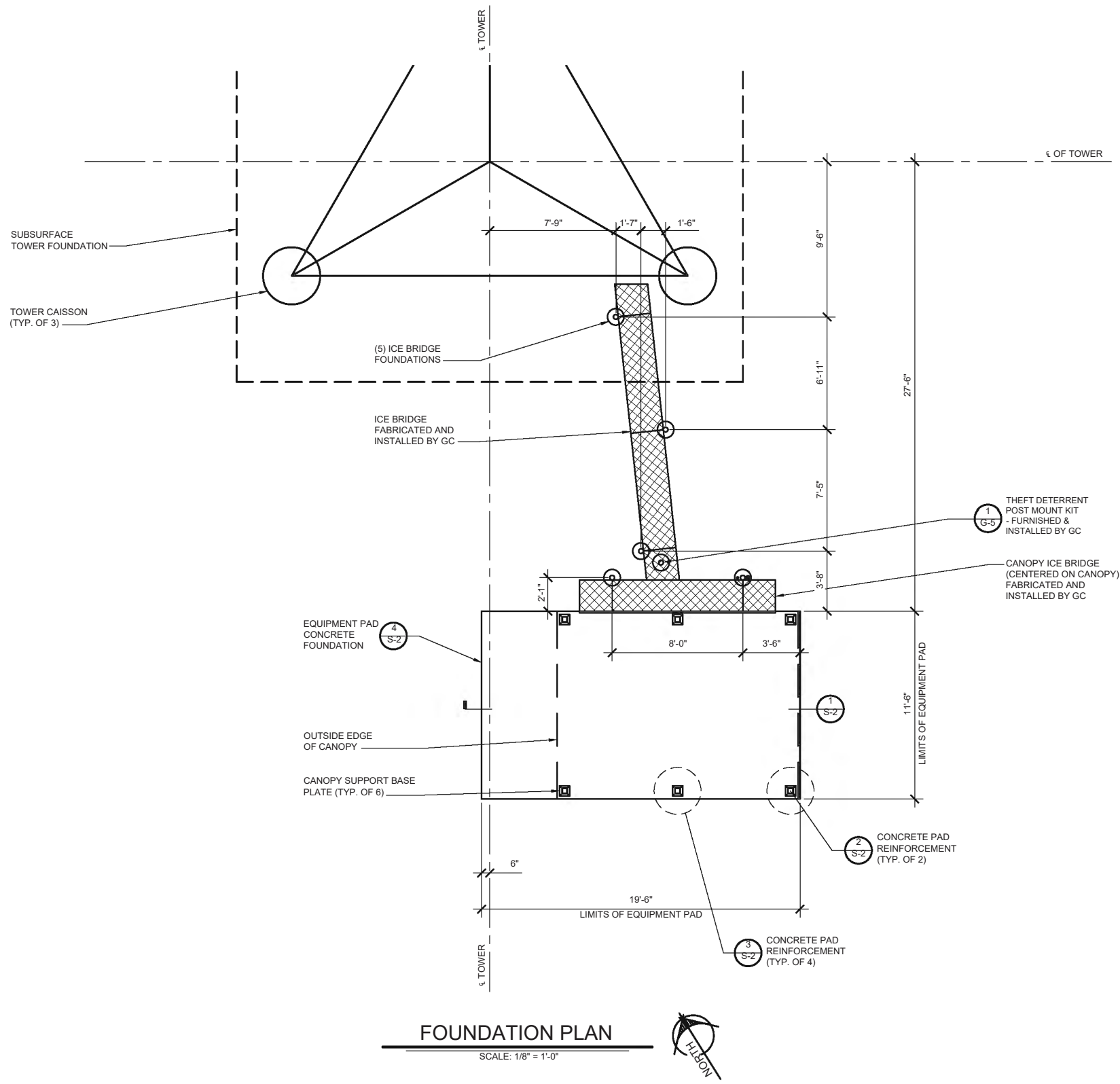

REV.	DATE	DESCRIPTION
A	02/08/2019	ISSUED FOR 90% REVIEW
B	02/22/19	ADDED DISTANCE TO HOUSE
C	02/24/19	REBUILDING CALL OUTS AND REVISED SHEET TITLE
D	08/09/19	FINAL CONSTRUCTION DRAWINGS

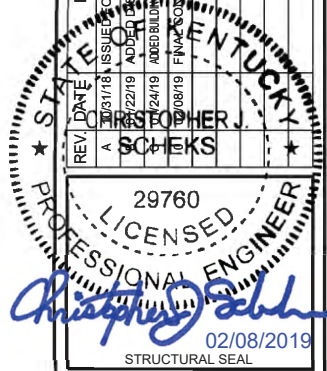

EV BARLOW
 2557 STEVE DENTON ROAD
 BARLOW, KY 42024

FOUNDATION DETAILS

ISSUED FOR:	
REVIEW	---
PERMIT	---
CONSTRUCTION	---
RECORD	---
PROJECT MANAGER	DESIGNER
TTP	DTC

JOB NO.
2017770.39

S-2

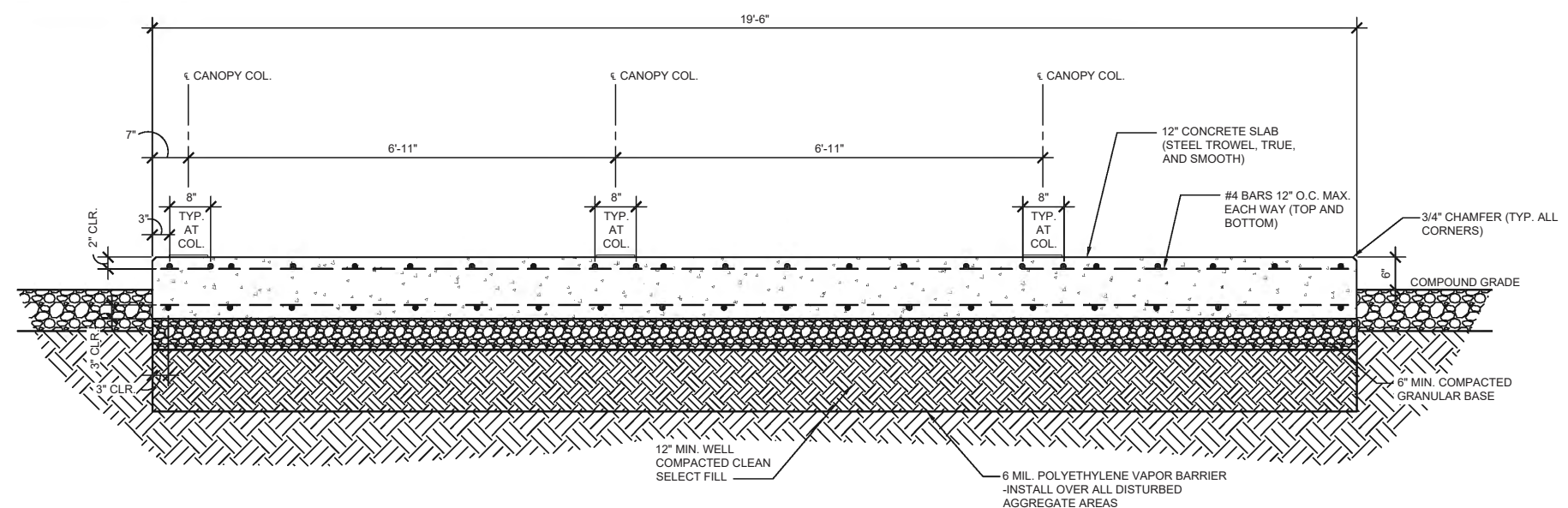

CONCRETE PAD SECTION
 SCALE: N.T.S. (1) S-2

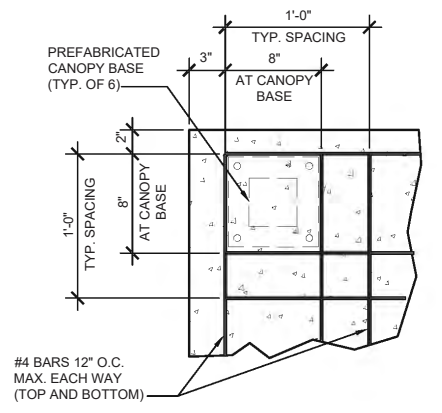

CORNER PAD REINFORCEMENT DETAIL
 SCALE: N.T.S. (TYP. OF 2) (2) S-2

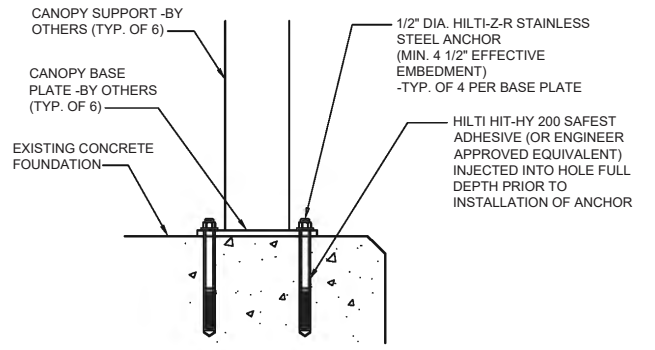

CANOPY BASE PLATE ANCHOR DETAIL
 SCALE: N.T.S. (4) S-2

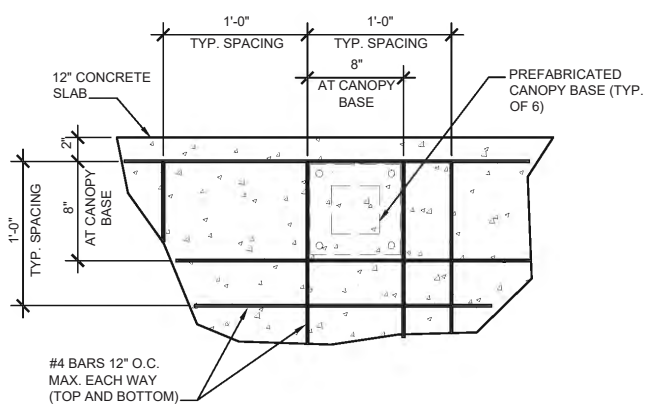

INTERMEDIATE PAD REINFORCEMENT DETAIL
 SCALE: N.T.S. (TYP. OF 4) (3) S-2

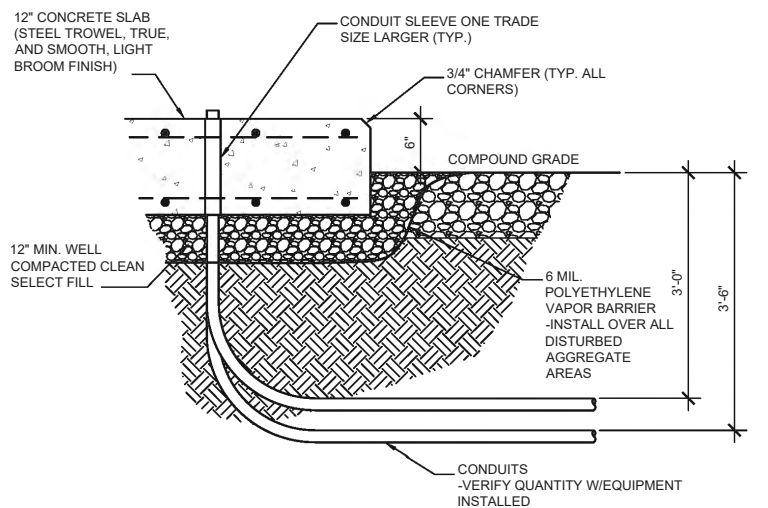

CONDUIT PENETRATION DETAIL
 SCALE: N.T.S. (5) S-2

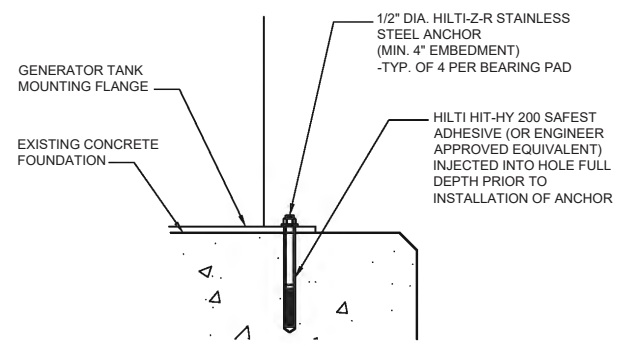

GENERATOR ANCHOR DETAIL
 SCALE: N.T.S. (7) S-2

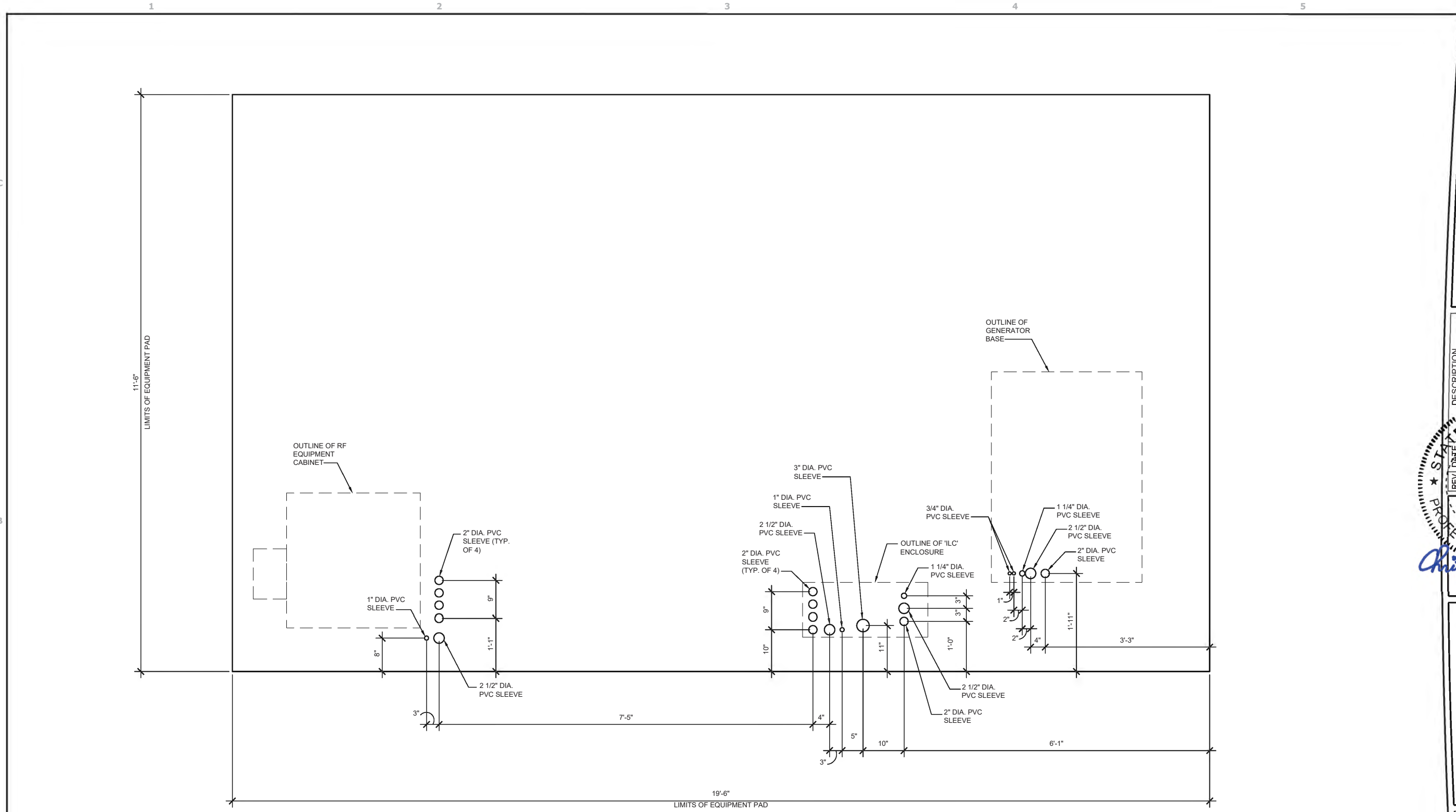

CONDUIT PENETRATION PLAN

SCALE: 1/2" = 1'-0"

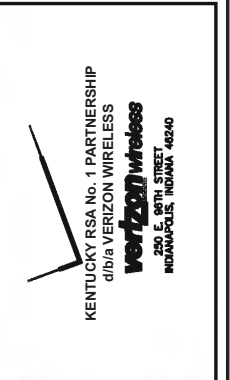

REV.	DATE	DESCRIPTION
A	02/08/2019	ISSUED FOR 90% REVIEW
	02/22/19	ADDED DISTANCE TO HOUSE
	02/24/19	REBUILT CALL OUTS AND REVISED SHEET TITLE
	08/09/19	FINAL CONSTRUCTION DRAWINGS

STATE OF KENTUCKY
 REGISTERED PROFESSIONAL ENGINEER
 29760
Christopher John
 02/08/2019
 STRUCTURAL SEAL

EV BARLOW
 2557 STEVE DENTON ROAD
 BARLOW, KY 42024

FOUNDATION CONDUIT PENETRATION PLAN

ISSUED FOR:	
REVIEW	--
PERMIT	--
CONSTRUCTION	--
RECORD	--

PROJECT MANAGER	DESIGNER
TTP	DTC

JOB NO.
2017770.39

S-3

Drawing Name: O:\2017\201777038\EV Barlow\AEC\DEV Barlow CD.dwg
 February 8, 2019 2:7 PM - skrschneer

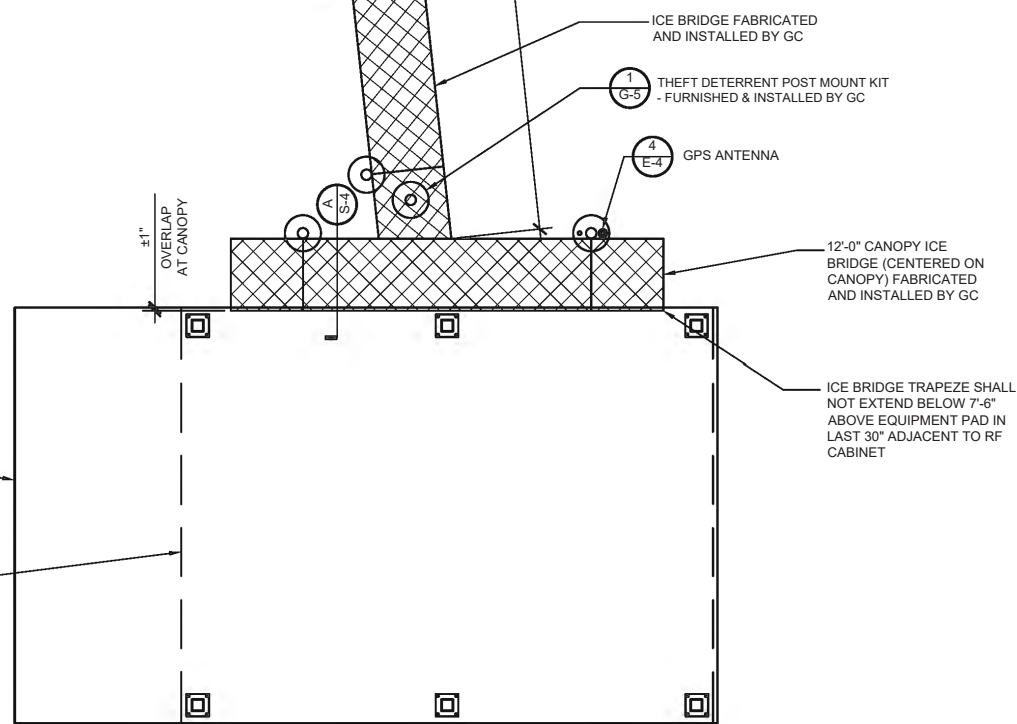
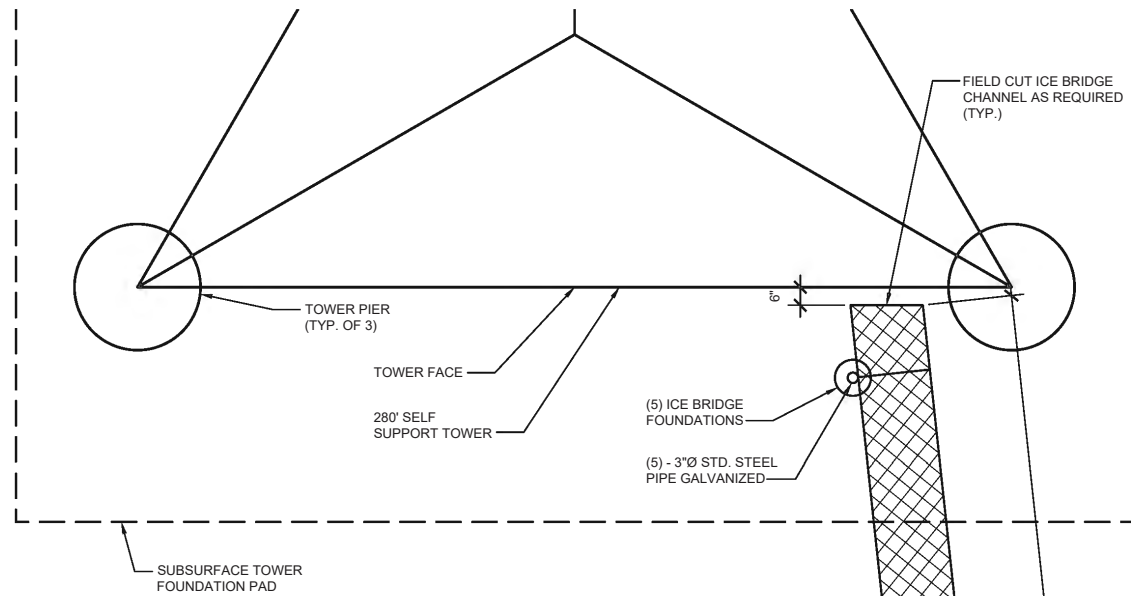

ICE BRIDGE PLAN

SCALE: 3/16" = 1'-0"

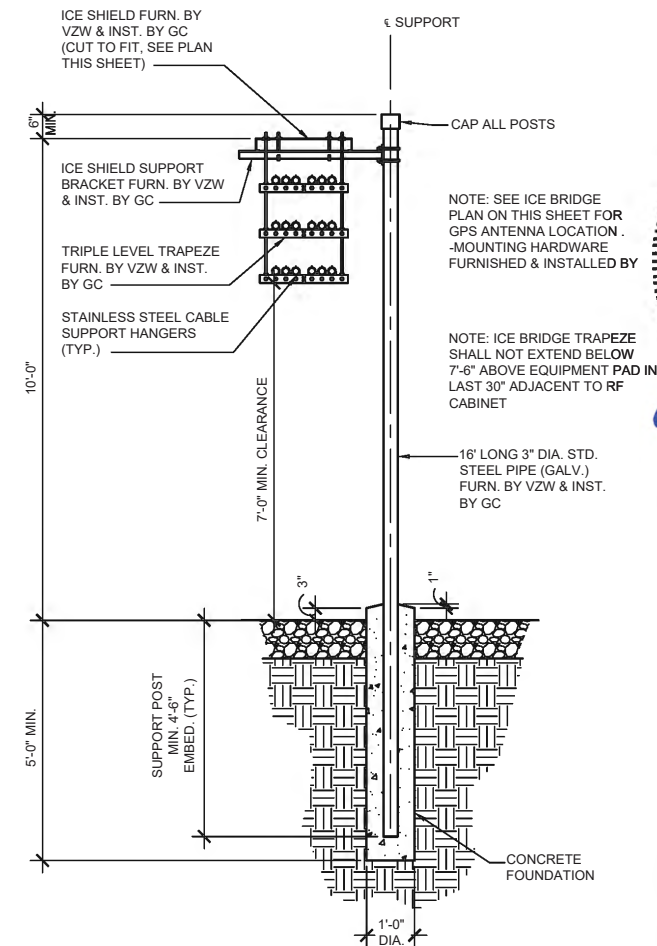

GPD GROUP, INC.
 520 South Main Street, Suite 2531
 Akron, OH 44311
 330.572.2100 Fax: 330.572.2102

KENTUCKY RSA No. 1 PARTNERSHIP
 d/b/a VERIZON WIRELESS
 Verizon Wireless
 250 E. 90TH STREET
 INDIANAPOLIS, INDIANA 46240

REV.	DATE	DESCRIPTION
A	02/08/2019	ISSUED FOR 90% REVIEW
B	02/22/19	ADDED DISTANCE TO HOUSE
C	02/24/19	ADDED BUILDING CALL OUTS AND REVISED SHEET TITLE
D	02/28/19	FINAL CONSTRUCTION DRAWINGS

STATE OF KENTUCKY
 PROFESSIONAL ENGINEER
 29760
 Christopher J. Schaefer
 02/08/2019
 STRUCTURAL SEAL

EV BARLOW
 2557 STEVE DENTON ROAD
 BARLOW, KY 42024
ICE BRIDGE DETAILS

ISSUED FOR:	
REVIEW	--
PERMIT	--
CONSTRUCTION	--
RECORD	--
PROJECT MANAGER	DESIGNER
TTP	DTC

JOB NO.
 2017770.39

S-4

ELECTRICAL NOTES:

- EMERGENCY GENERATOR SHALL BE AS MANUFACTURED BY HOFFMAN ENCLOSURE (P/N A865JFGQRPWR) OR APPROVED EQUAL.
- GENERATOR EMERGENCY STOP SWITCH SHALL BE OF A SINGLE PUSH BUTTON OPERATING MODE USING A MAINTAINED PUSH/PULL ACTUATOR AS MANUFACTURED BY PILLA ELECTRICAL PRODUCTS (P/N GS120) OR APPROVED EQUAL.
- CONTACT BLOCKS SHALL BE RATED AT CONTINUOUS CURRENT OF 10A @ 120 VAC.
- PROVIDE 6'-0" MAX. LIQUIDTIGHT FLEXIBLE METAL CONDUIT AT ALL EQUIPMENT AND GENERATOR CONNECTIONS.
- ALL CONDUIT SHALL BE ROUTED WITHIN 2'-0" OF PERIMETER COMPOUND FENCE WHERE APPLICABLE.
- CONDUIT TRENCH WIDTH SHALL NOT EXCEED 18" AT ALL ACCESS DRIVE LOCATIONS AND WHEN CROSSING THE COMPOUND GATE OPENING.
- ALL CONDUIT RACEWAYS BETWEEN CABINETS ABOVE PAD SHALL BE 2" DIAMETER IMC WITH WEATHERPROOF FITTINGS.
- NO JOINT SERVICE TRENCHES ALLOWED ON VERIZON WIRELESS INSTALLATIONS. A MINIMUM 12" OF CLEAR SOIL MUST BE MAINTAINED BETWEEN SERVICES.

EMERGENCY GENERATOR STOP SWITCH MOUNTED IN ENCLOSURE
 EMERGENCY GENERATOR STOP ENCLOSURE MOUNTED TO CANOPY UTILITY FRAME
 SEE PAD UTILITY PLAN ON SHEET E-2 FOR EQUIPMENT AND GENERATOR CONDUIT DESCRIPTIONS
 VZW 20kW DIESEL GENERATOR
 VERIZON WIRELESS 11'-6"x19'-6" CONCRETE RADIO EQUIPMENT PAD
 VERIZON WIRELESS 11'-6"x14'-9" RADIO EQUIPMENT CANOPY

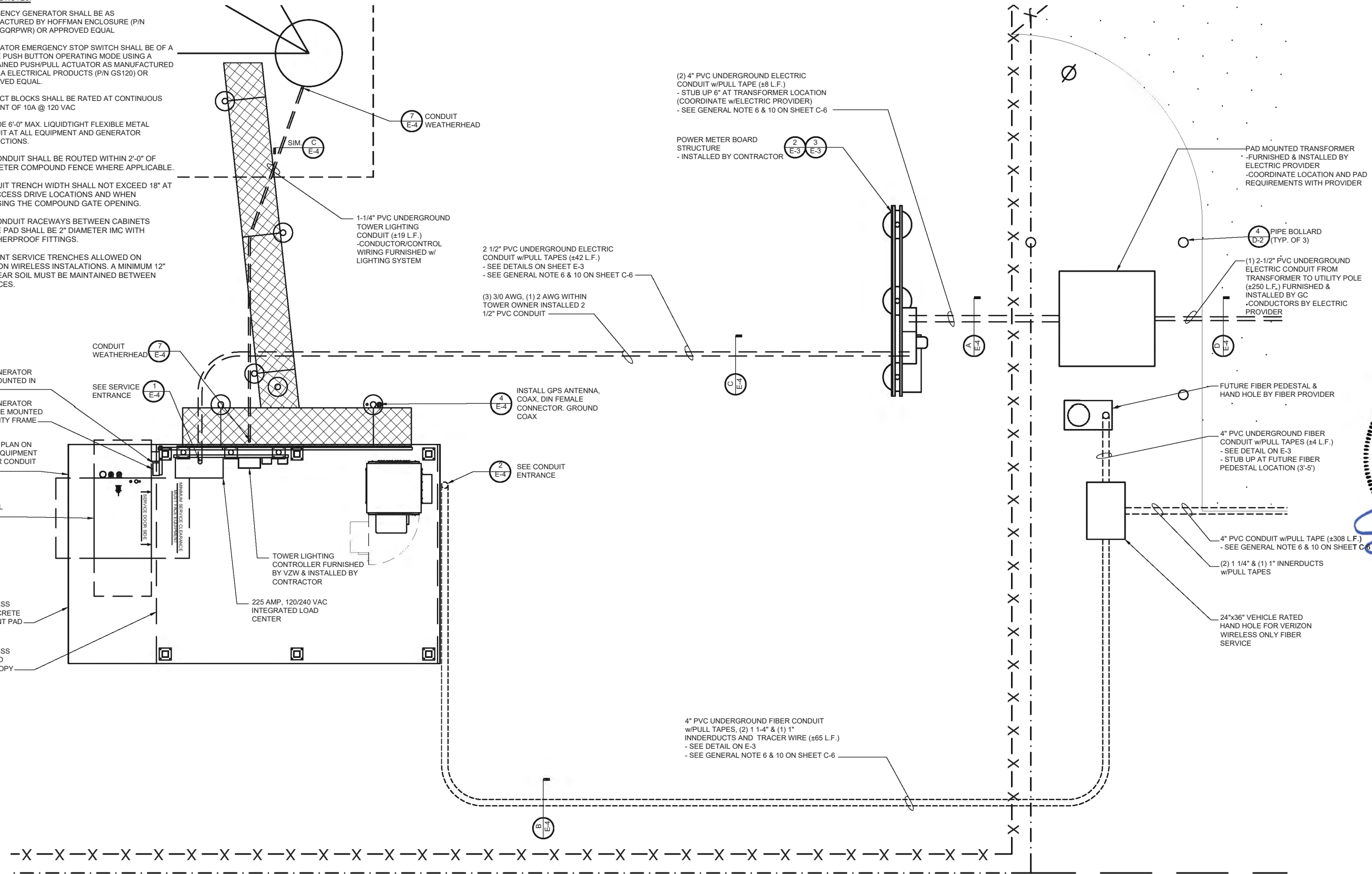

SITE UTILITY PLAN

SCALE: N.T.S.



GPD GROUP, INC.
 520 South Main Street, Suite 2531
 Akron, OH 44311
 330.572.2100 Fax: 330.572.2102

KENTUCKY RSA No. 1 PARTNERSHIP
Verizon Wireless
 d/b/a VERIZON WIRELESS
 250 E. 9TH STREET
 INDIANAPOLIS, INDIANA 46240

REVISION	DESCRIPTION
1	ISSUED FOR 90% REVIEW
2	ISSUED FOR 100% REVIEW
3	ISSUED FOR PERMIT
4	ISSUED FOR CONSTRUCTION
5	ISSUED FOR RECORD

STEVEN P. SCHAUB
 29008
 LICENSED PROFESSIONAL ENGINEER
 02/08/2019
 ELECTRICAL SEAL

EV BARLOW
 2557 STEVE DENTON ROAD
 BARLOW, KY 42024
SITE UTILITY PLAN

ISSUED FOR:	
REVIEW	--
PERMIT	--
CONSTRUCTION	--
RECORD	--

PROJECT MANAGER	DESIGNER
TTP	DTC

JOB NO.
2017770.39

E-1

Drawing Name: O:\2017\201777038\EV Barlow\AEC\DEV Barlow CD.dwg
February 8, 2019 2:7 PM - skrschneer

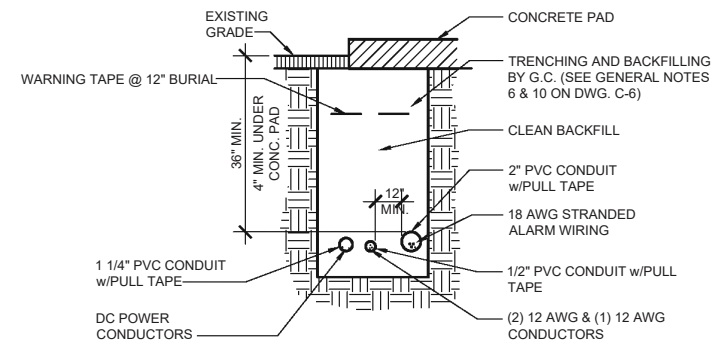

POWER PLANT FEEDER TRENCH SECTION DETAIL

SCALE: N.T.S.

A
E-2

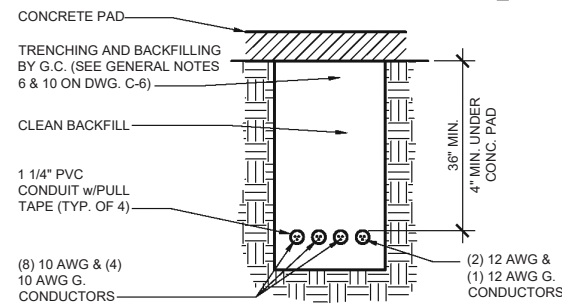

POWER PLANT FEEDER TRENCH SECTION DETAIL

SCALE: N.T.S.

B
E-2

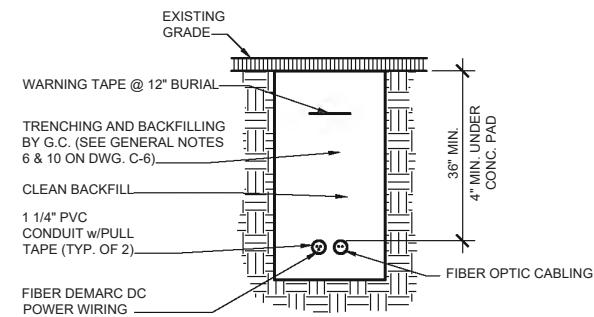

FIBER DEMARC TRENCH SECTION DETAIL

SCALE: N.T.S.

C
E-2

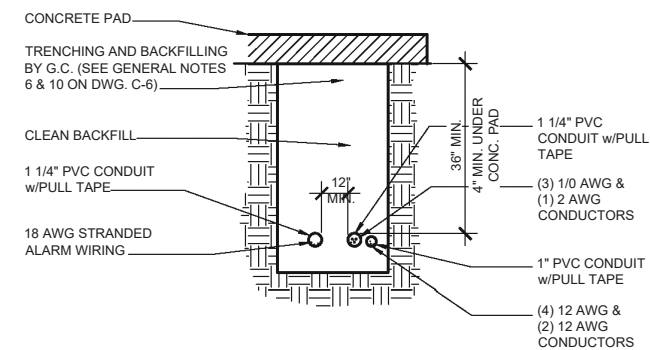

GENERATOR FEEDER TRENCH SECTION DETAIL

SCALE: N.T.S.

D
E-2

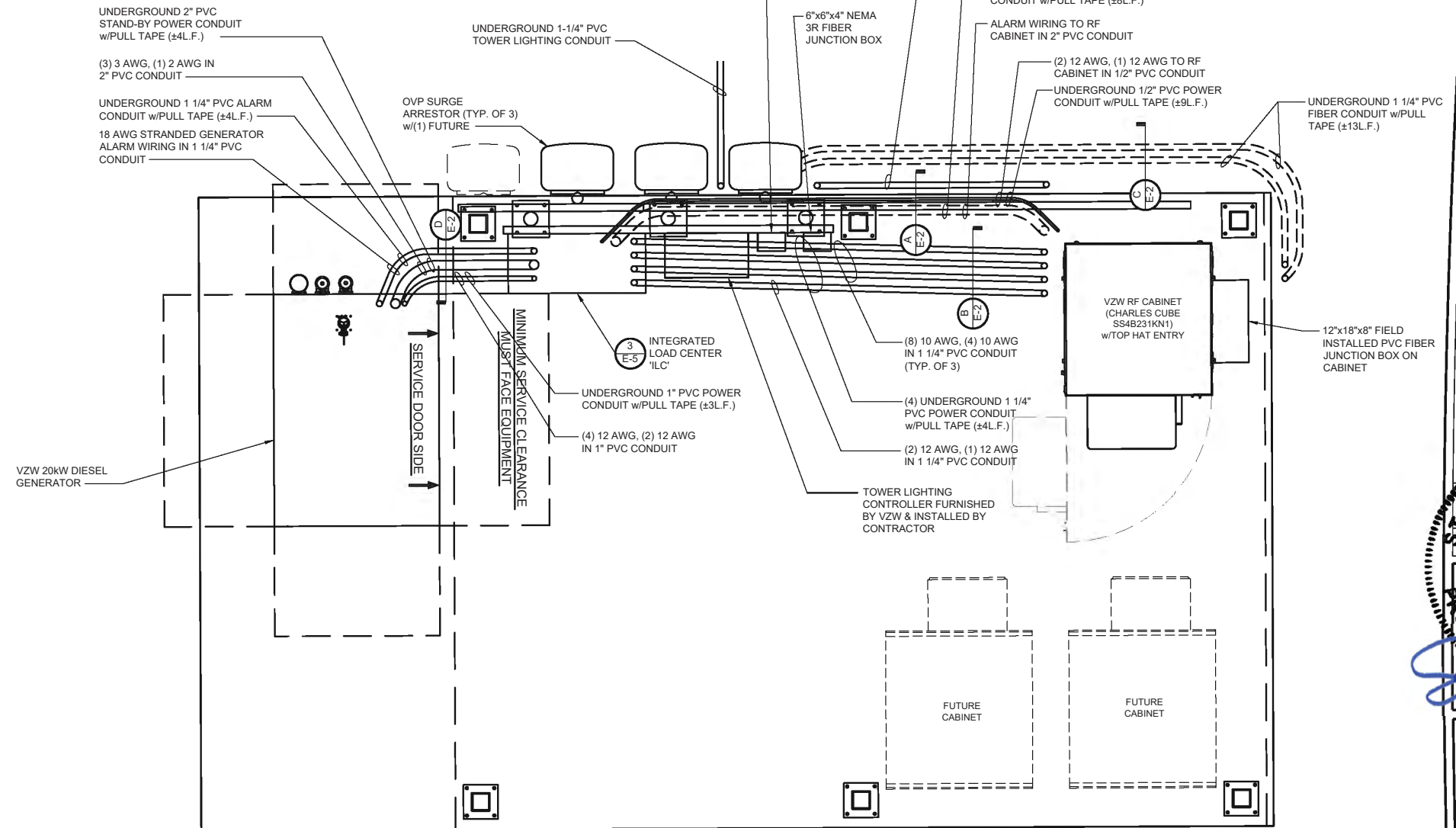

EQUIPMENT PAD UTILITY PLAN

SCALE: 3/8" = 1'-0"



ELECTRICAL NOTES:

1. EMERGENCY GENERATOR SHALL BE AS MANUFACTURED BY HOFFMAN ENCLOSURE (P/N A865JFGQRPWR) OR APPROVED EQUAL.
2. GENERATOR EMERGENCY STOP SWITCH SHALL BE OF A SINGLE PUSH BUTTON OPERATING MODE USING A MAINTAINED PUSH/PULL ACTUATOR AS MANUFACTURED BY PILLA ELECTRICAL PRODUCTS (P/N GS120) OR APPROVED EQUAL.
3. CONTACT BLOCKS SHALL BE RATED AT CONTINUOUS CURRENT OF 10A @ 120 VAC
4. PROVIDE 6'-0" MAX. LIQUIDTIGHT FLEXIBLE METAL CONDUIT AT ALL EQUIPMENT AND GENERATOR CONNECTIONS.
5. ALL CONDUIT SHALL BE ROUTED WITHIN 2'-0" OF PERIMETER COMPOUND FENCE WHERE APPLICABLE.
6. CONDUIT TRENCH WIDTH SHALL NOT EXCEED 18" AT ALL ACCESS DRIVE LOCATIONS AND WHEN CROSSING THE COMPOUND GATE OPENING.
7. ALL CONDUIT RACEWAYS BETWEEN CABINETS ABOVE PAD SHALL BE 2" DIAMETER IMC WITH WEATHERPROOF FITTINGS.
8. NO JOINT SERVICE TRENCHES ALLOWED ON VERIZON WIRELESS INSTALATIONS. A MINIMUM 12" OF CLEAR SOIL MUST BE MAINTAINED BETWEEN SERVICES.

GPD GROUP, INC.
520 South Main Street, Suite 2531
Akron, OH 44311
330.572.2100 Fax: 330.572.2102

KENTUCKY RSA No. 1 PARTNERSHIP
Verizon Wireless
d/b/a VERIZON WIRELESS
250 E. 9TH STREET
INDIANAPOLIS, INDIANA 46240

REVISION	DESCRIPTION
A	ISSUED FOR 90% REVIEW
B	ISSUED FOR 100% REVIEW
C	ISSUED FOR 100% REVIEW
D	ISSUED FOR 100% REVIEW
E	ISSUED FOR 100% REVIEW
F	ISSUED FOR 100% REVIEW
G	ISSUED FOR 100% REVIEW
H	ISSUED FOR 100% REVIEW
I	ISSUED FOR 100% REVIEW
J	ISSUED FOR 100% REVIEW
K	ISSUED FOR 100% REVIEW
L	ISSUED FOR 100% REVIEW
M	ISSUED FOR 100% REVIEW
N	ISSUED FOR 100% REVIEW
O	ISSUED FOR 100% REVIEW
P	ISSUED FOR 100% REVIEW
Q	ISSUED FOR 100% REVIEW
R	ISSUED FOR 100% REVIEW
S	ISSUED FOR 100% REVIEW
T	ISSUED FOR 100% REVIEW
U	ISSUED FOR 100% REVIEW
V	ISSUED FOR 100% REVIEW
W	ISSUED FOR 100% REVIEW
X	ISSUED FOR 100% REVIEW
Y	ISSUED FOR 100% REVIEW
Z	ISSUED FOR 100% REVIEW

STEVEN P. SCHAUB
29008
LICENSED PROFESSIONAL ENGINEER
02/08/2019
ELECTRICAL SEAL

EV BARLOW
2557 STEVE DENTON ROAD
BARLOW, KY 42024

EQUIPMENT PAD UTILITY PLAN & EQUIPMENT PAD TRENCH SECTIONS

ISSUED FOR:	
REVIEW	--
PERMIT	--
CONSTRUCTION	--
RECORD	--
PROJECT MANAGER	DESIGNER
TTP	DTC

JOB NO.
2017770.39

E-2

VERIZON PANEL "A" SCHEDULE

MAIN: 225/2 VOLTAGE: 120/240 PHASE: 1 WIRE: 3

DESCRIPTION	BRKR.	WATTS	S.C.		WATTS	BRKR.	DESCRIPTION
RECTIFIER #1	20/2	1800	1	2	1800	20/2	RECTIFIER #2
RECTIFIER #3	20/2	1800	3	4	1800	20/2	RECTIFIER #4
RECTIFIER #5	20/2	1800	5	6	1800	20/2	RECTIFIER #6
RECTIFIER #7	20/2	1800	7	8	1800	20/2	RECTIFIER #8
SPACE			9	10	1800		SPACE
SPACE			11	12	1800		SPACE
SPACE			13	14	1800		SPACE
SPACE			15	16	1800		SPACE
SPACE			17	18			SPACE
SPACE			19	20			SPACE
SPACE			21	22			SPACE
SPACE			23	24			SPACE
SPACE			25	26			SPACE
SPACE			27	28			SPACE
SPACE			29	30	TBD		SPACE
GFCI RECEPTACLE (RF CABINET)	15/1	180	31	32	TBD	TBD	TOWER LIGHTING
CANOPY LIGHTS	20/1	126	33	34	180	15/1	GFCI RECEPTACLE
GEN. BLOCK HEATER	20/1	1500	35	36	250	20/1	GEN. BATTERY CHARGER

SURGE ARRESTOR

SURFACE MOUNTED NEMA 3R w/DOOR
22K AIC BREAKERS
(E.C. SHALL VERIFY AIC RATINGS W/LOCAL POWER CO.)

NON-CONTINUOUS LOAD = 0.00 KW, 00.00 AMPS
CONTINUOUS LOAD = 31.04 KW X 1.25 = 38.80 KW, 161.67 AMPS
TOTAL CONNECTED LOAD = 38.80 KW, 161.67 AMPS

PANEL SCHEDULE "A"

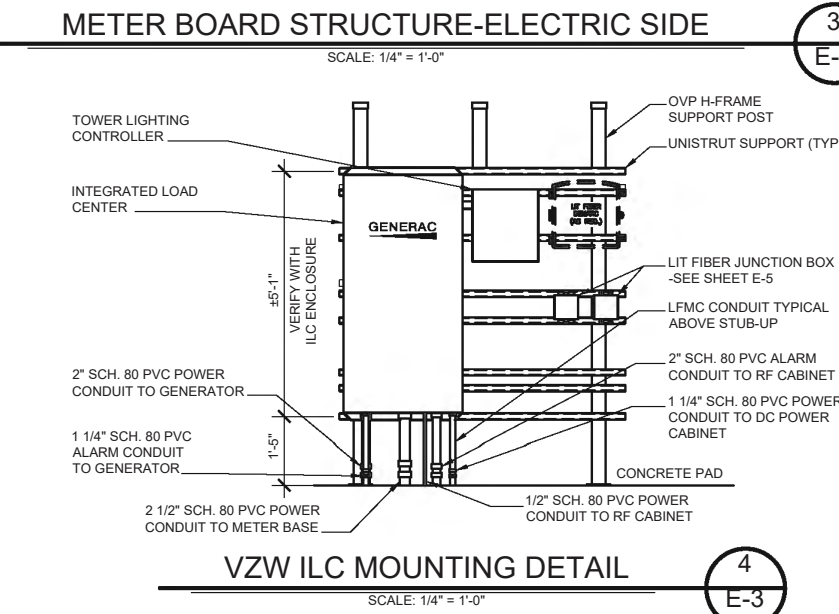
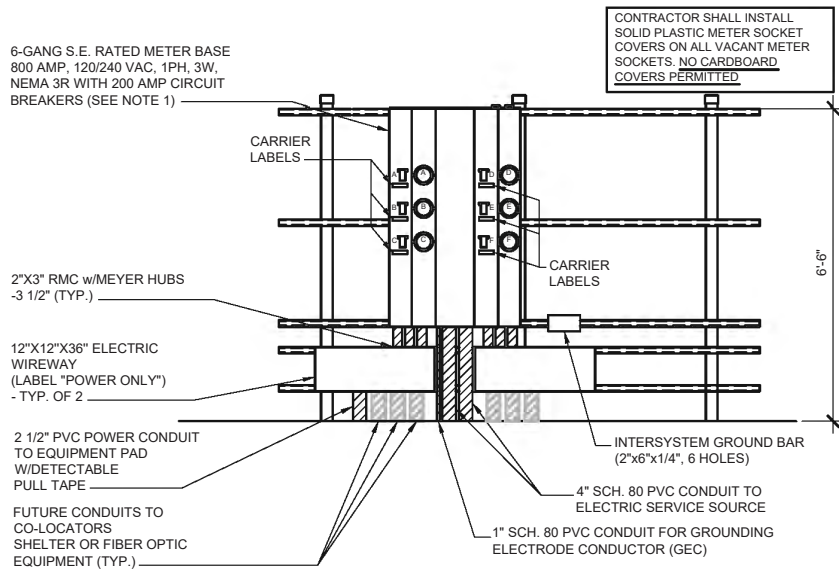
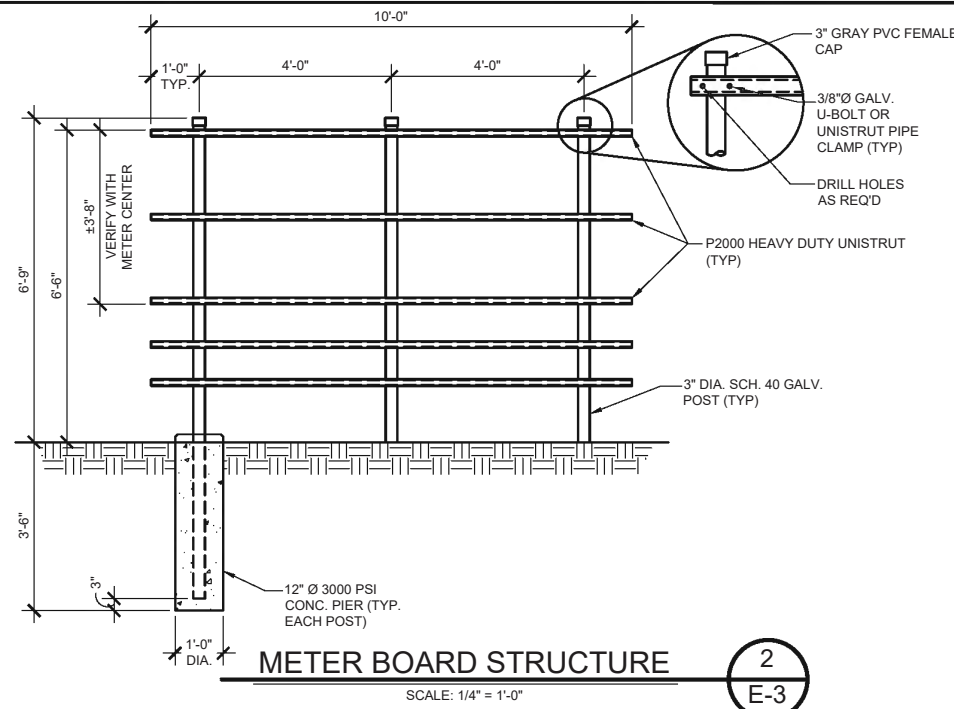
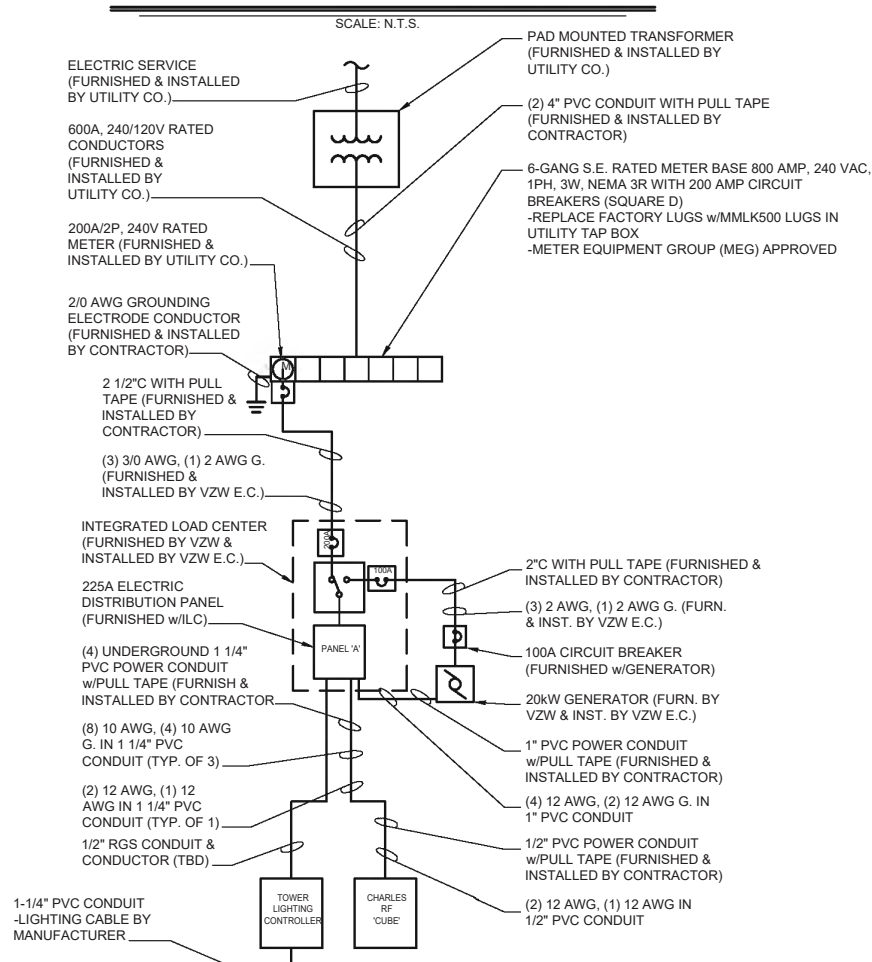

GENERAL ELECTRICAL NOTES

- UNLESS NOTED AS VERIZON WIRELESS GENERAL CONTRACTOR OR GC, ALL WORK ITEMS ON ELECTRICAL "E" & GROUNDING "G" SHEETS SHALL BE PERFORMED BY THE GENERAL CONTRACTOR'S ELECTRICAL CONTRACTOR. ALL WORK SHOWN AS NEW UNLESS NOTED EXISTING.
- THE GENERAL CONTRACTOR AND VERIZON WIRELESS ELECTRICAL CONTRACTORS SHALL BE LICENSED TO PERFORM WORK IN THE COUNTY OF THIS PROJECT AND SHALL BE RESPONSIBLE FOR OBTAINING AN ELECTRICAL PERMIT FROM THE COUNTY.
- UNDERGROUND CONDUIT SHALL BE SCH. 40 PVC PLASTIC DUCT WITH ALL BENDS MINIMUM 24" RADIUS 90° SWEEP SCH. 80 UNLESS OTHERWISE NOTED ON DRAWINGS. ELECTRICAL AND FIBER UTILITY LATERAL CONDUITS SHALL BE MINIMUM 36" RADIUS 90° SWEEP SCH. 80. ALL PVC SCH-80 PIPING AND FITTINGS SHALL USE BELL END WHERE FEASIBLE.
- ALL WORK SHALL BE IN ACCORDANCE WITH N.F.P.A. AND N.E.C. CODES, NEMA STANDARDS AND ALL LOCAL CODES.
- PRIOR TO TRENCHING AND FOR COORDINATING OF THE FIBER AND ELECTRICAL SERVICES, SEE SHEET C-6 GENERAL NOTE #6 FOR UTILITY CONTACT NAMES & PHONE NUMBERS.
- ABOVE GRADE RISER CONDUIT SHALL BE RIGID SCH. 80 PVC WITH MATCHING FITTINGS UNLESS NOTED OTHERWISE.
- ALL WIRE SHALL BE COPPER, 600V THHN-2/THWN-2 OR XHHW-2 90°C UNLESS NOTED OTHERWISE.
- ALL ELECTRICAL CONTRACTORS SHALL ABIDE BY ALL GUIDELINES REQUIRED BY TOWER OWNER AND VERIZON WIRELESS, INCLUDING BUT NOT LIMITED TO, a) STAGE CONSTRUCTION AND REPORT WHEN ON AND OFF THE SITE. b) PROVIDE LOG BOOK RECORDS OF PERSONNEL ON TOWER. c) PROVIDE R.F. MONITORING DEVICES TO TOWER PERSONNEL. d) VERIZON WIRELESS TO INSPECT ALL TRENCHING BEFORE BACKFILLING.
- THE ELECTRICAL CONTRACTOR SHALL INSTALL ALL UNDERGROUND CONDUITS SHOWN ON PLANS UNLESS NOTED OTHERWISE. ALL UNDERGROUND CONDUIT SHALL BE STUBBED-UP AND CAPPED AT THE LOCATION INDICATED ON PLANS. VZW CONTRACTOR SHALL COMPLETE ALL CONDUIT TERMINATIONS TO VZW ENCLOSURES.
- THE VZW ELECTRICAL CONTRACTOR SHALL VERIFY ELECTRICAL SERVICE REQUIRED - 120/240V, SINGLE PHASE, 200 AMP BEFORE ROUGH IN.
- GENERAL CONTRACTOR AND VZW ELECTRICAL CONTRACTORS SHALL PROVIDE FIRE WATCH DURING ALL WELDING OPERATIONS. TWO (2) HAND HELD 30 LB. FIRE EXTINGUISHERS & ADEQUATE WATER SUPPLY SHALL BE APPROVED BY THE CLIENT AND THE TOWNSHIP WATER AUTHORITY.
- SEAL ALL PENETRATIONS WITH SILICONE SEALANT.
- ELECTRICAL WORK PRESENTS SPECIFIC THREATS TO THE HEALTH AND SAFETY OF WORKERS ON SITE. SPECIFICALLY ELECTROCUTIONS ARE THE FOURTH LEADING CAUSE OF DEATH ON CONSTRUCTION SITES. ALL ELECTRICAL WORKERS SHALL HAVE CURRENT CERTIFICATIONS WHICH SATISFY ALL TRAINING REQUIREMENTS FOR THE ELECTRICAL WORK THEY ARE PERFORMING PER OSHA STANDARDS. ALL ELECTRICAL WORKERS SHALL ADHERE TO ALL SAFETY RULES AND REGULATIONS FOR WORKER AND PUBLIC SAFETY. ALL WORK SHALL BE PERFORMED BY QUALIFIED ELECTRICIANS TRAINED FOR THE TYPE OF WORK AND THE VOLTAGES PRESENT FOR EACH TASK. THE CONTRACTOR SHALL REVIEW ALL LANDOWNER, PRIME CONTRACTOR, CARRIER, OSHA, NFPA 70E, AND LOCAL SAFETY GUIDELINES AND AT ALL TIMES SHALL CONFORM TO THE MOST RESTRICTIVE OF THESE STANDARDS TO ENSURE A SAFE WORKPLACE.
- CONNECT NEUTRAL TERMINAL IN SERVICE DISCONNECTING DEVICE TO GROUNDING ELECTRODE. (2/0 AWG TINNED STRANDED COPPER GROUNDING ELECTRODE CONDUCTOR IN 1" PVC CONDUIT). CONNECT FIRST GROUNDING ELECTRODE TO SECOND GROUNDING ELECTRODE WITH 2/0 AWG TINNED STRANDED COPPER CONDUCTOR EXOTHERMICALLY WELDED TO ELECTRODES.
- VZW E.C. SHALL VERIFY SUFFICIENT CAPACITY EXISTS AT EXISTING METER CENTER. NOTIFY ENGINEER IMMEDIATELY IF SERVICE IS NOT ADEQUATE.
- REFER TO ELECTRICAL SITE PLAN FOR CONDUIT AND WIRE REQUIREMENTS.
- ALL ELECTRICAL EQUIPMENT PLACARDS MUST BE ENGRAVED PLASTIC LABELS ONLY. NO P-TOUCH LABELS ARE TO BE USED. PLACARDS SHALL BE 1 1/2" x 5" IN SIZE AND PERMANENTLY AFFIXED TO THE ENCLOSURES EASILY VISIBLE LOCATIONS.
- VERIZON WIRELESS ELECTRICAL PLACARD REQUIREMENTS:
 - AVAILABLE FAULT CURRENT RATING FROM UTILITY PROVIDER WITH DATE.
 - VERIZON WIRELESS SERVICE DISCONNECT AT METER BASE.
 - VERIZON MAIN BREAKER AT INTEGRATED LOAD CENTER "ILC".
 - GENERATOR NEUTRAL CONDUCTOR BONDED TO SERVICE GROUNDING ELECTRODE IN THIS ENCLOSURE AT METER CENTER AND INTEGRATED LOAD CENTER "ILC" NEUTRAL BAR.
 - VERIZON WIRELESS GENERATOR
 - VERIZON WIRELESS FIBER ONLY AT ALL VERIZON WIRELESS FIBER HAND HOLES FASTENED TO INSIDE WALL OF HAND HOLE.
- ALL EQUIPMENT SHALL BE GROUNDED PER LATEST EDITION OF NEC AND AS INDICATED ON GROUNDING PLAN.
- ELECTRICAL EQUIPMENT SHALL BE MIN 3'-0" FROM ANY STRUCTURE AND AS REQUIRED BY LOCAL UTILITY COMPANIES.
- 2 AWG BARE SOLID TINNED COPPER WIRE LEADS FROM NEW H-FRAME STRUCTURE TO BE BONDED TO EXISTING GROUNDING SYSTEM (TYP)
- ALL METALLIC CABINETS & ENCLOSURES MUST BE GROUNDED WITH 2 AWG TO GROUND RING.
- ALL ABOVE GRADE GROUND VZW CONNECTIONS SHALL BE IN 1/2" FLEXIBLE PVC CONDUIT w/ANTI-THEFT COMPOUND. ALL OTHER LEADS SHALL BE IN 1/2" PVC CONDUIT.
- ALL HARDWARE USED MUST BE GALVANIZED OR STAINLESS STEEL, NO ZINC OR OTHER MATERIAL IS TO BE USED.
- VERIZON WIRELESS FURNISH & INSTALL ALL INNER CONNECTING CONDUITS BETWEEN CABINETS AND LAND ALL AC POWER TO VZW EQUIPMENT.
- ALL CONDUIT RUNS SHALL HAVE A CONTINUOUS SLOPE DOWNWARD AND AWAY FROM THE METERBOARD SO THAT WATER WILL NOT FLOW FROM THE EQUIPMENT. TRENCHES SHALL BE EXCAVATED ALONG STRAIGHT LINES BEFORE CONDUIT ARE INSTALLED SO THE ELEVATION CAN BE ADJUSTED, IF NECESSARY, TO AVOID UNSEEN OBSTACLES.
- PRIOR TO THE SUBMISSION OF BIDS, THE GENERAL CONTRACTOR AND HIS SUBCONTRACTORS SHALL VERIFY ALL DETAILS AND SCHEDULES ON THE DRAWINGS AND SPECIFICATIONS PROVIDED BY THE OWNER, FOR MEANING OF ABBREVIATIONS AND ADDITIONAL REQUIREMENTS AND INFORMATION, CHECK STRUCTURAL AND OTHER MECHANICAL AND ELECTRICAL DRAWINGS FOR SCALE, SPACE LIMITATIONS, DOOR SWINGS, ADJACENT CARRIER EQUIPMENT COORDINATION AND ADDITIONAL INFORMATION, ETC. REPORT ANY DISCREPANCIES, CONFLICTS, ETC. TO THE OWNER BEFORE SUBMITTING BIDS.

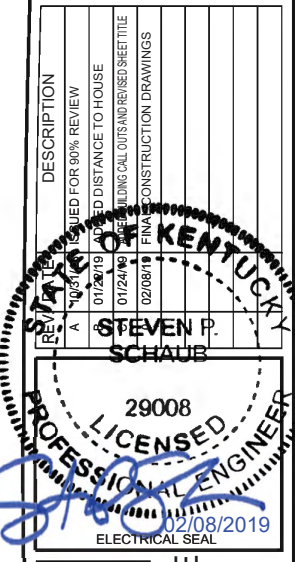
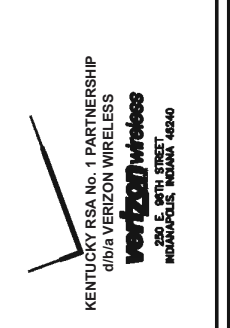

EV BARLOW
2557 STEVE DENTON ROAD
BARLOW, KY 42024

PANEL SCHEDULE, ONE LINE DIAGRAM, ELECTRICAL NOTES AND DETAILS

ISSUED FOR:	
REVIEW	---
PERMIT	---
CONSTRUCTION	---
RECORD	---
PROJECT MANAGER	DESIGNER
TTP	DTC

JOB NO.
2017770.39

E-3

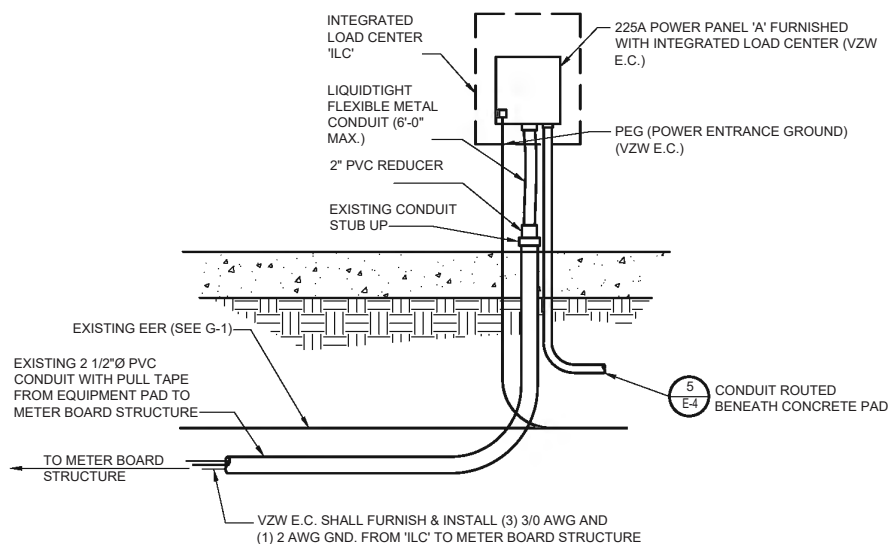

SERVICE ENTRANCE DETAIL

SCALE: N.T.S.

1
E-4

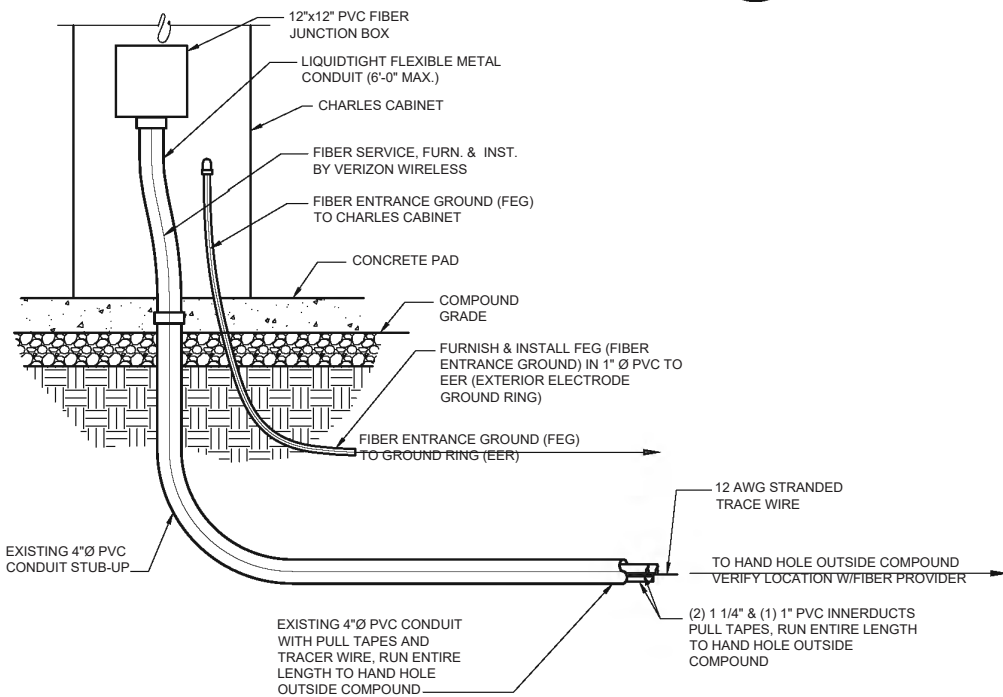

FIBER CONDUIT ENTRANCE DETAIL

SCALE: N.T.S.

2
E-4

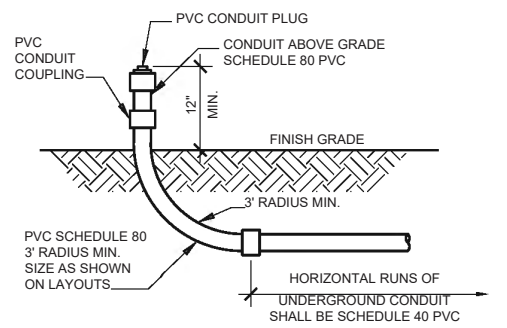

UNDERGROUND CONDUIT STUB-UP DETAIL

SCALE: N. T. S.

3
E-4

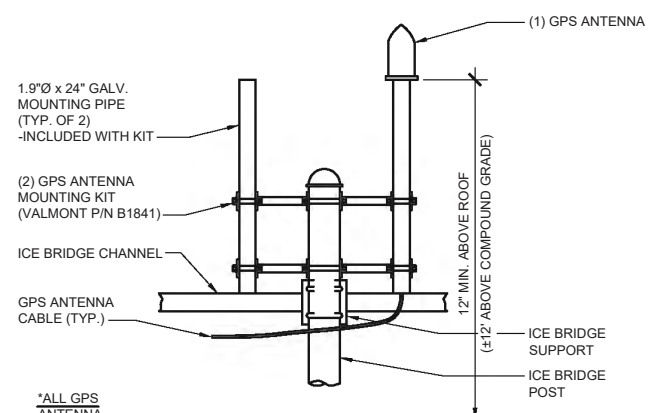

GPS MOUNT DETAIL

SCALE: N.T.S.
(BY GC)

4
E-4

NOTE:
GPS ANTENNA MUST BE INSTALLED IN SUCH A MANNER AS TO PROVIDE A 360° CLEAR VIEW OF THE SKY AT ITS LOWEST MOUNTING POINT

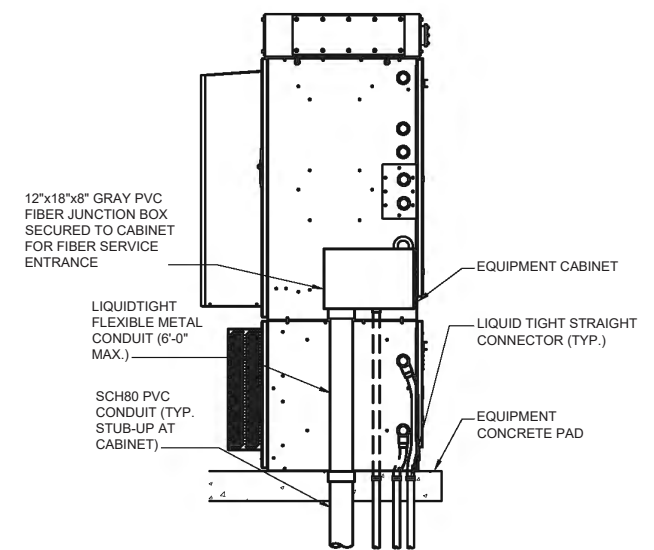

TYP. CABINET CONDUIT ENTRANCE DETAIL

SCALE: N.T.S.
(BY GC)

5
E-4



FIBER HAND HOLE PLACARD DETAIL

SCALE: N.T.S.

6
E-4

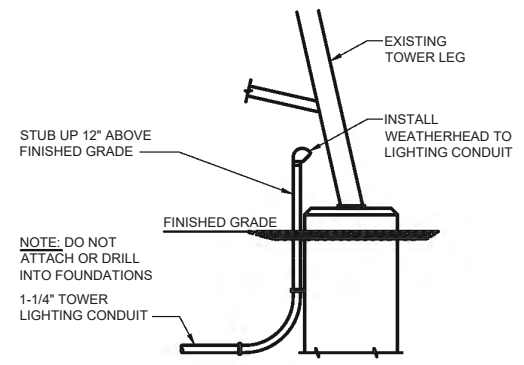

TOWER LIGHTING CONDUIT DETAIL

SCALE: N.T.S.

7
E-4

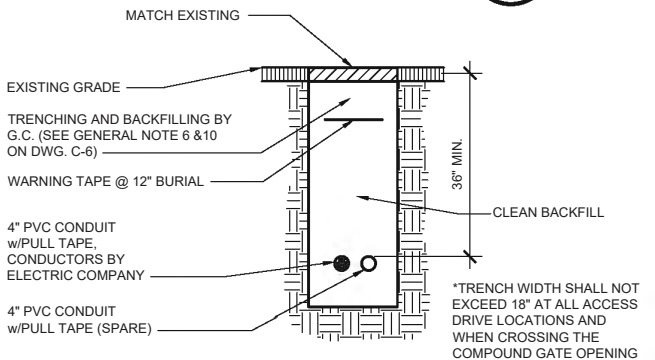

SERVICE LATERAL TRENCH SECTION DETAIL

SCALE: N.T.S.

A
E-4

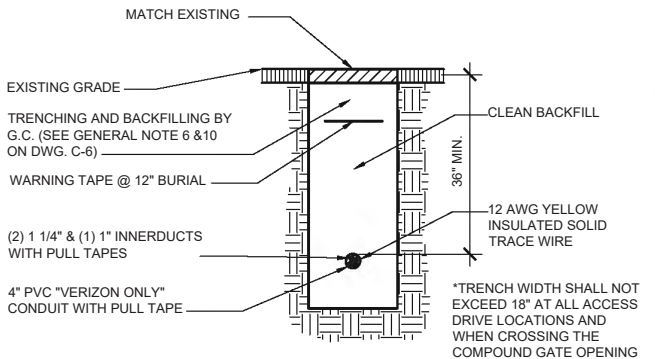

FIBER TRENCH SECTION DETAIL

SCALE: N.T.S.

B
E-4

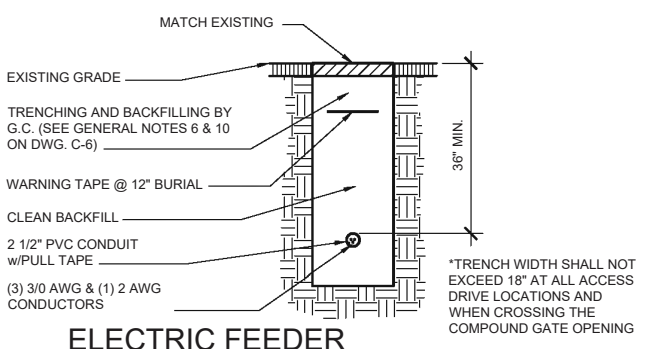

ELECTRIC FEEDER TRENCH SECTION DETAIL

SCALE: N.T.S.

C
E-4

GPD GROUP, INC.
520 South Main Street, Suite 2531
Akron, OH 44311
330.572.2100 Fax: 330.572.2102

KENTUCKY RSA No. 1 PARTNERSHIP
d/b/a Verizon Wireless
250 E. 9TH STREET
INDIANAPOLIS, INDIANA 46240

REVISIONS

NO.	DATE	DESCRIPTION
1	01/28/19	ISSUED FOR 90% REVIEW
2	01/28/19	ISSUED DISTANCE TO HOUSE
3	01/28/19	ISSUED BUILDING CALL OUTS AND REVISED SHEET TITLE
4	02/08/19	FINAL CONSTRUCTION DRAWINGS

STEVEN P. SCHAUB
29008
LICENSED PROFESSIONAL ENGINEER
02/08/2019
ELECTRICAL SEAL

EV BARLOW
2557 STEVE DENTON ROAD
BARLOW, KY 42024

ELECTRICAL DETAILS

ISSUED FOR:

REVIEW	---
PERMIT	---
CONSTRUCTION	---
RECORD	---

PROJECT MANAGER	DESIGNER
TTP	DTC

JOB NO.
2017770.39

E-4

NO.	DATE	DESCRIPTION
1	01/28/19	ISSUED FOR 90% REVIEW
2	01/28/19	REVISED DISTANCE TO HOUSE
3	01/28/19	REVISED DISTANCE TO HOUSE
4	01/28/19	REVISED DISTANCE TO HOUSE
5	01/28/19	REVISED DISTANCE TO HOUSE
6	01/28/19	REVISED DISTANCE TO HOUSE
7	01/28/19	REVISED DISTANCE TO HOUSE
8	01/28/19	REVISED DISTANCE TO HOUSE
9	01/28/19	REVISED DISTANCE TO HOUSE
10	01/28/19	REVISED DISTANCE TO HOUSE
11	01/28/19	REVISED DISTANCE TO HOUSE
12	01/28/19	REVISED DISTANCE TO HOUSE
13	01/28/19	REVISED DISTANCE TO HOUSE
14	01/28/19	REVISED DISTANCE TO HOUSE
15	01/28/19	REVISED DISTANCE TO HOUSE
16	01/28/19	REVISED DISTANCE TO HOUSE
17	01/28/19	REVISED DISTANCE TO HOUSE
18	01/28/19	REVISED DISTANCE TO HOUSE
19	01/28/19	REVISED DISTANCE TO HOUSE
20	01/28/19	REVISED DISTANCE TO HOUSE

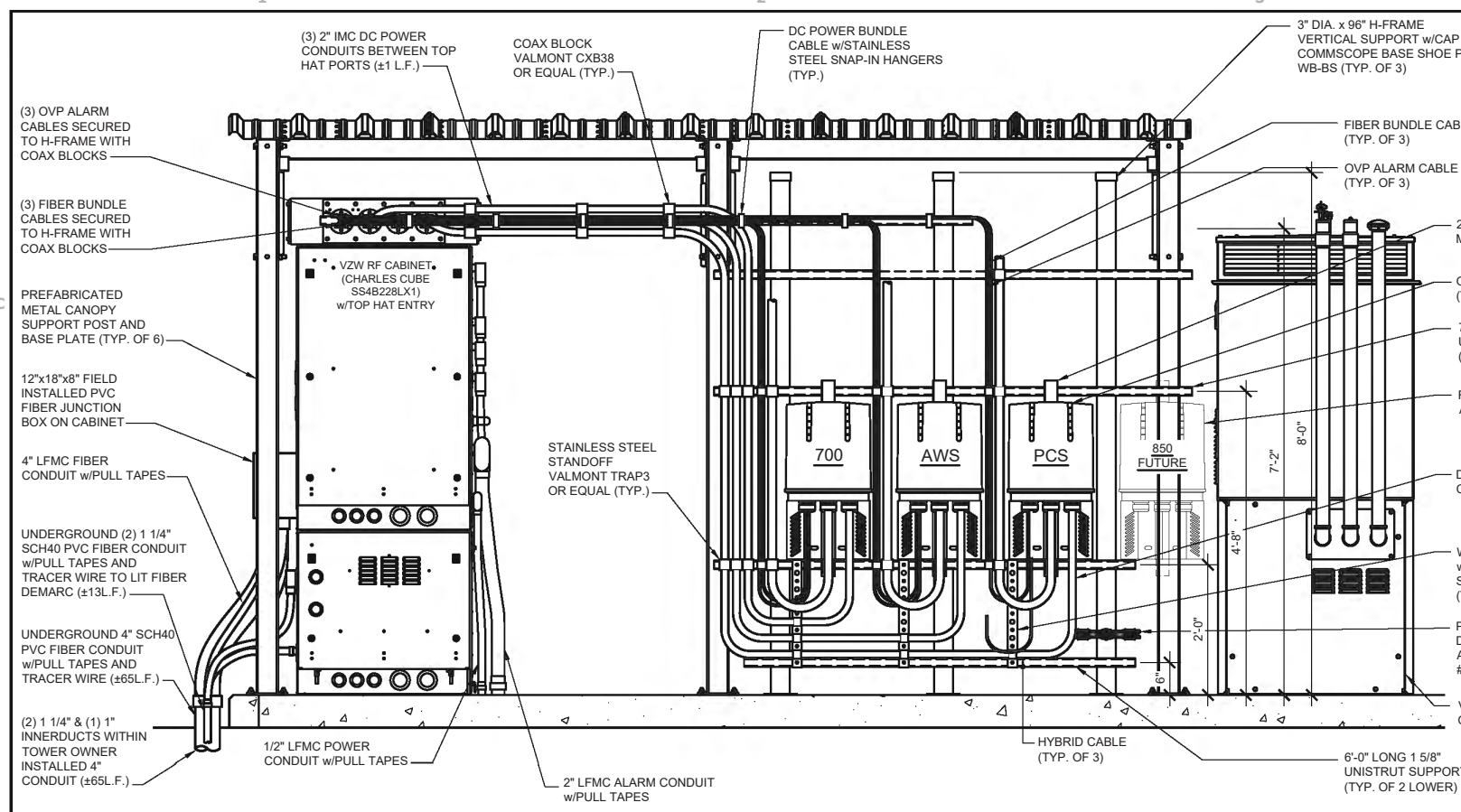
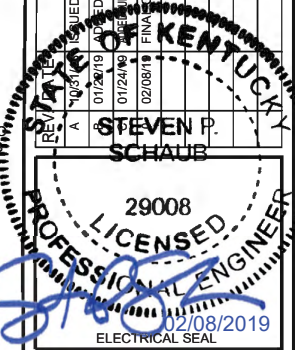

OUTDOOR OVP EQUIPMENT ELEVATION (OVP SIDE) - REAR

SCALE: 3/8" = 1'-0"

1
E-5

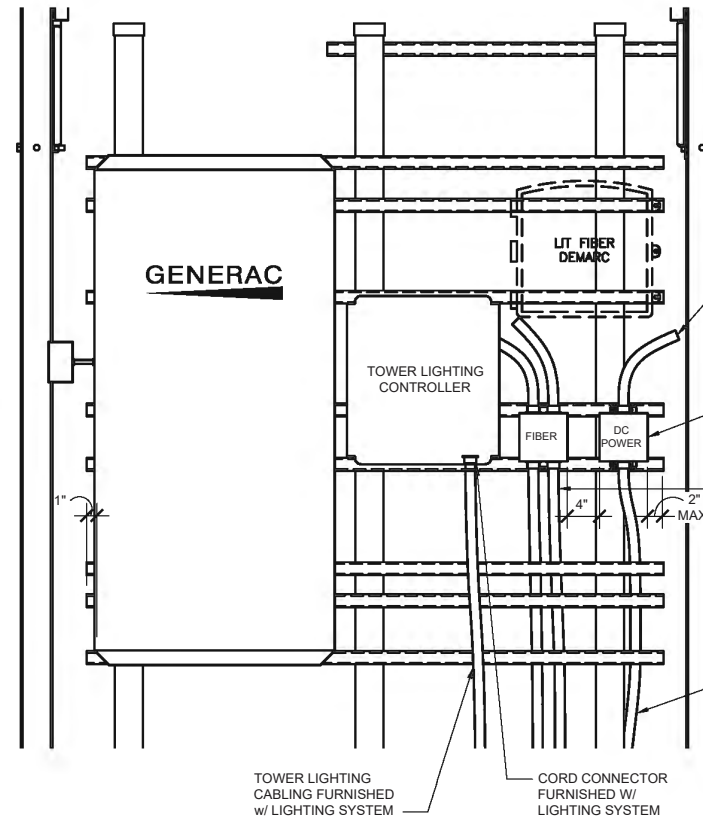

ENLARGED OVP H-FRAME ELEVATION (LIT FIBER DEMARC)

SCALE: 1/2" = 1'-0"

3
E-5

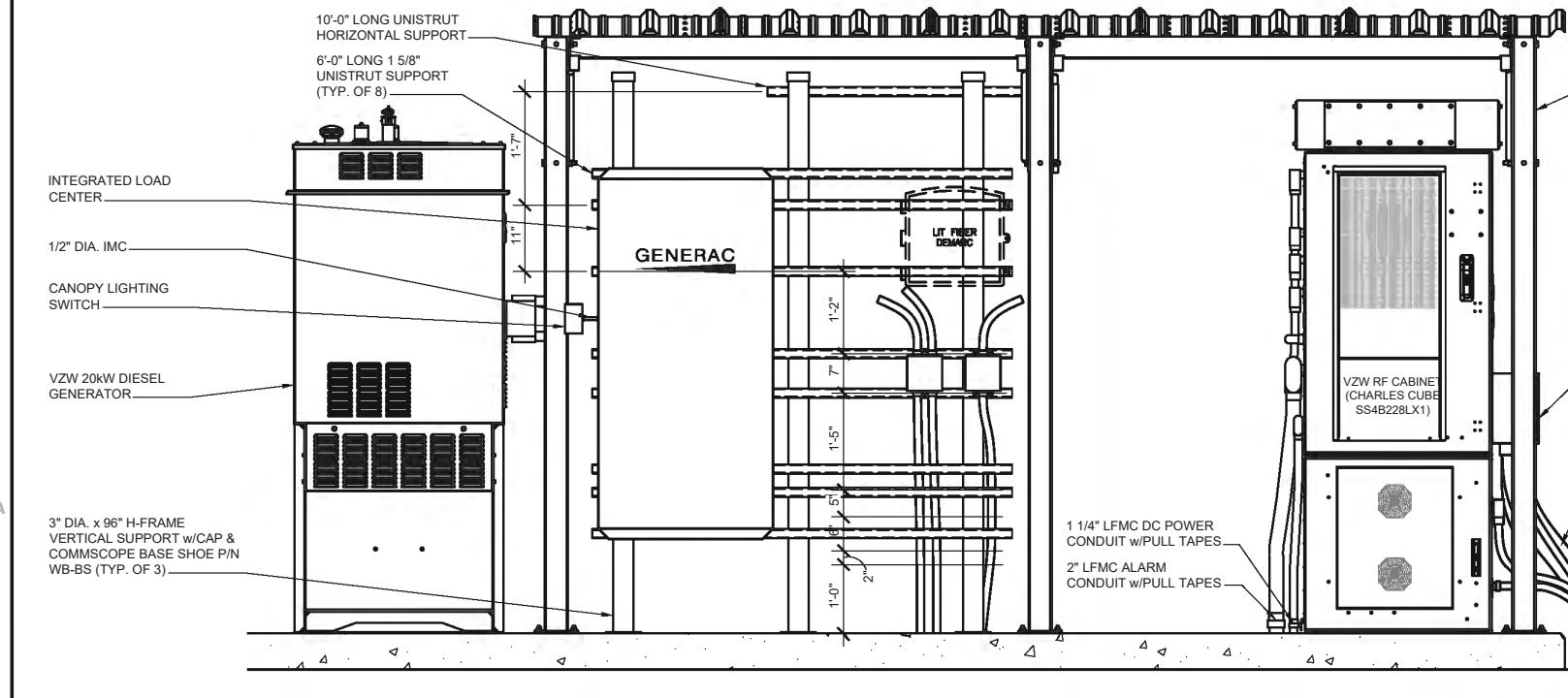

OUTDOOR OVP EQUIPMENT ELEVATION (ILC SIDE) - FRONT

SCALE: 3/8" = 1'-0"

2
E-5

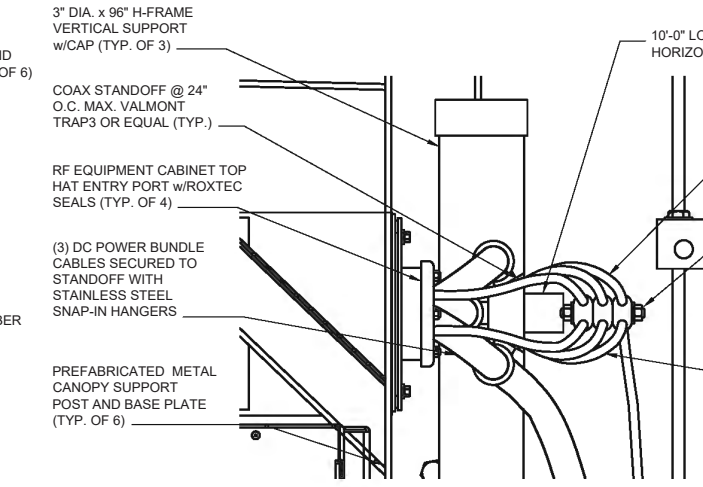

ENLARGED CABLE SUPPORT DETAIL

SCALE: 1 1/2" = 1'-0"

4
E-5

EV BARLOW
 2557 STEVE DENTON ROAD
 BARLOW, KY 42024

OVP & INTEGRATED LOAD CENTER H-FRAME ELEVATIONS AND DETAILS

ISSUED FOR:	
REVIEW	--
PERMIT	--
CONSTRUCTION	--
RECORD	--

PROJECT MANAGER	DESIGNER
TTP	DTC

JOB NO.
2017770.39

E-5

1

2

3

4

5

NOTE:
 FIBER OPTIC INNERDUCTS SHALL TERMINATE INSIDE CHARLES CABINET ONLY

NOTE:
 VERIFY INTERIOR EQUIPMENT LOCATION PRIOR TO JUNCTION BOX FASTENER INSTALLATION. NO SHARP FASTENER EDGES PERMITTED WITHIN CHARLES CABINET

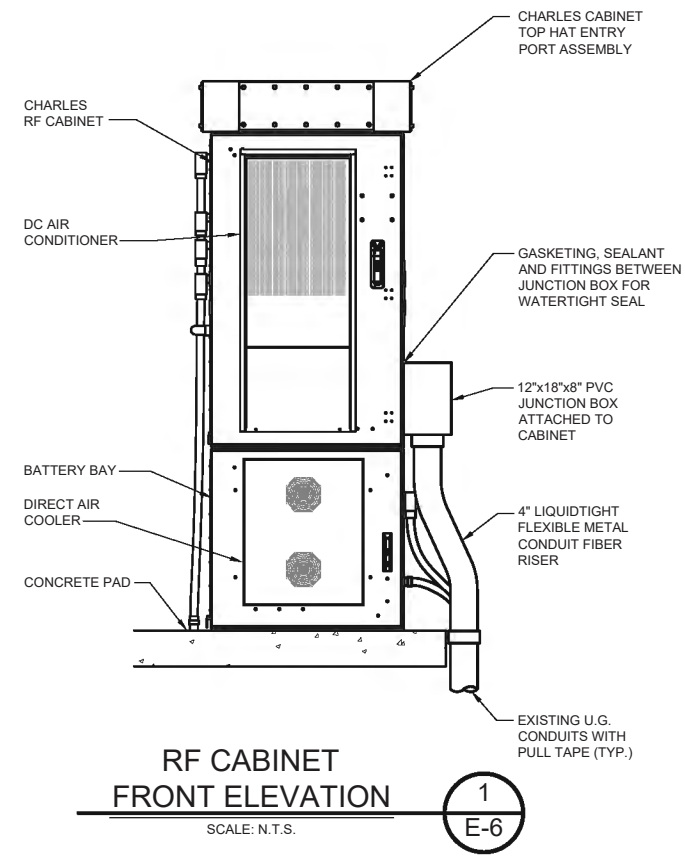
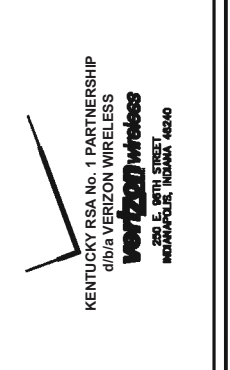

RF CABINET FRONT ELEVATION
 SCALE: N.T.S. **1**
 E-6

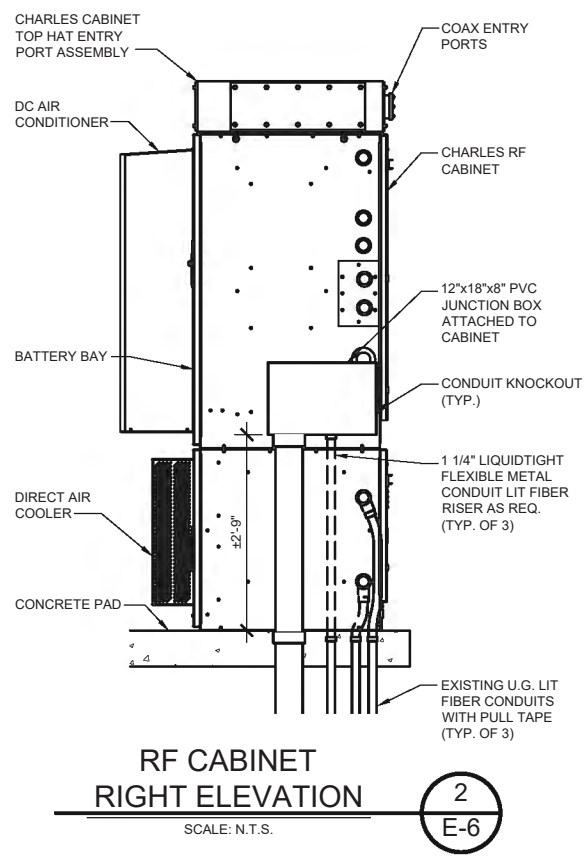

RF CABINET RIGHT ELEVATION
 SCALE: N.T.S. **2**
 E-6

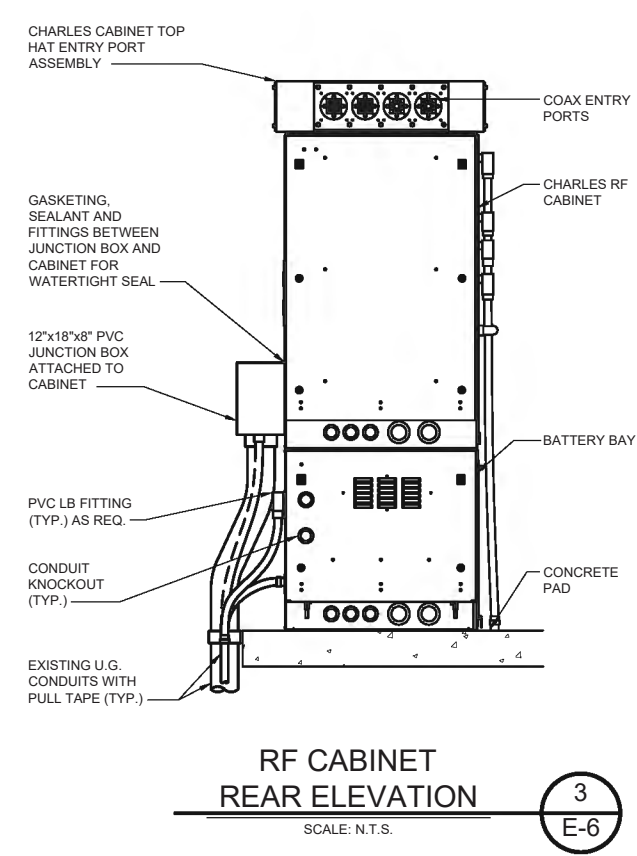

RF CABINET REAR ELEVATION
 SCALE: N.T.S. **3**
 E-6

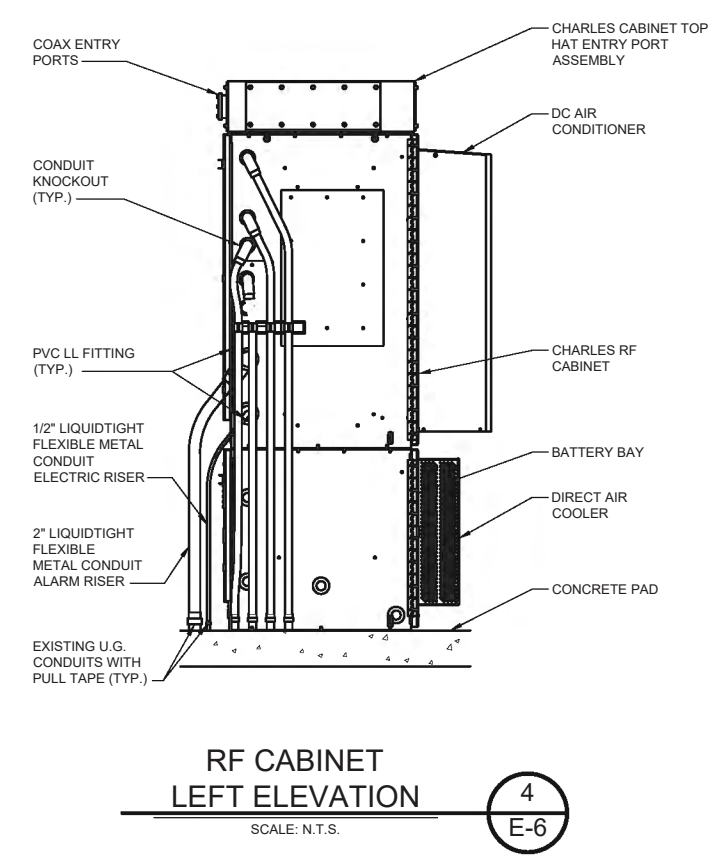

RF CABINET LEFT ELEVATION
 SCALE: N.T.S. **4**
 E-6

REV.	DATE	DESCRIPTION
A	10/21/18	ISSUED FOR 90% REVIEW
B	01/22/19	ADDED DISTANCE TO HOUSE
C	01/24/19	ADDED BUILDING CALL OUTS AND REVISED SHEET TITLE
D	02/08/19	FINAL CONSTRUCTION DRAWINGS

REFERENCE ONLY

EV BARLOW
 2557 STEVE DENTON ROAD
 BARLOW, KY 42024
EQUIPMENT CABINET ELEVATIONS

ISSUED FOR:	
REVIEW	--
PERMIT	--
CONSTRUCTION	--
RECORD	--
PROJECT MANAGER	DESIGNER
TTP	DTC

JOB NO.
2017770.39

E-6

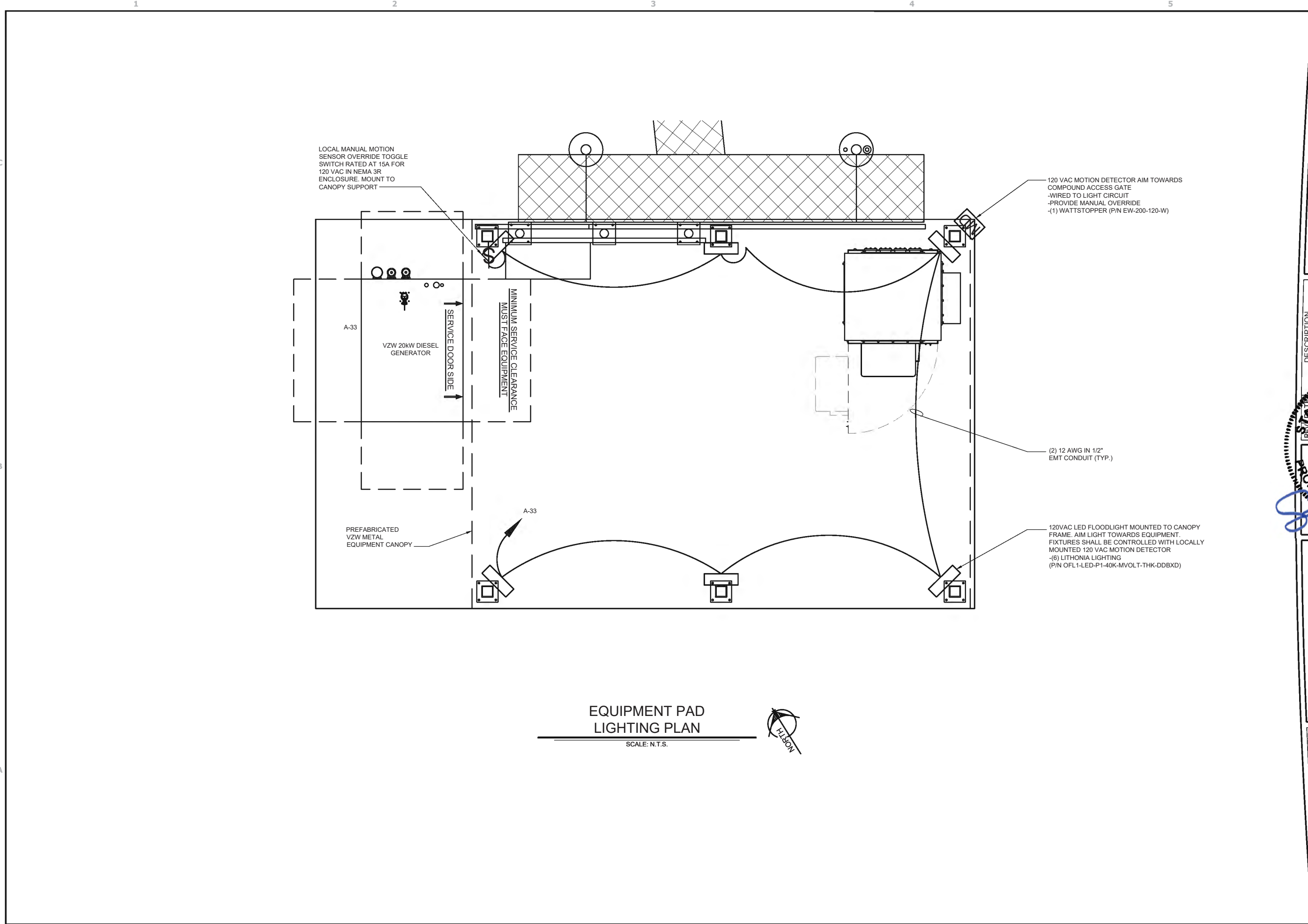

**EQUIPMENT PAD
 LIGHTING PLAN**

SCALE: N.T.S.



KENTUCKY RSA No. 1 PARTNERSHIP
Verizon Wireless
 d/b/a VERIZON WIRELESS
 250 E. 9TH STREET
 INDIANAPOLIS, INDIANA 46240

REVISION	DESCRIPTION
A	REVISED FOR 90% REVIEW
B	REVISED DISTANCE TO HOUSE
C	REVISED BUILDING CALL OUTS AND REVISED SHEET TITLE
D	REVISED CONSTRUCTION DRAWINGS
E	FINAL

STATE OF KENTUCKY
 STEVEN P. SCHAUB
 29008
LICENSED PROFESSIONAL ENGINEER
 02/08/2019
 ELECTRICAL SEAL

EV BARLOW
 2557 STEVE DENTON ROAD
 BARLOW, KY 42024
**EQUIPMENT PAD
 LIGHTING PLAN**

ISSUED FOR:	
REVIEW	--
PERMIT	--
CONSTRUCTION	--
RECORD	--

PROJECT MANAGER	DESIGNER
TTP	DTC

JOB NO.
2017770.39

E-7

Drawing Name: C:\2017\201777039\EV Barlow\AEC\DEV Barlow CD.dwg
 February 8, 2019 2:28 PM - skrschneer

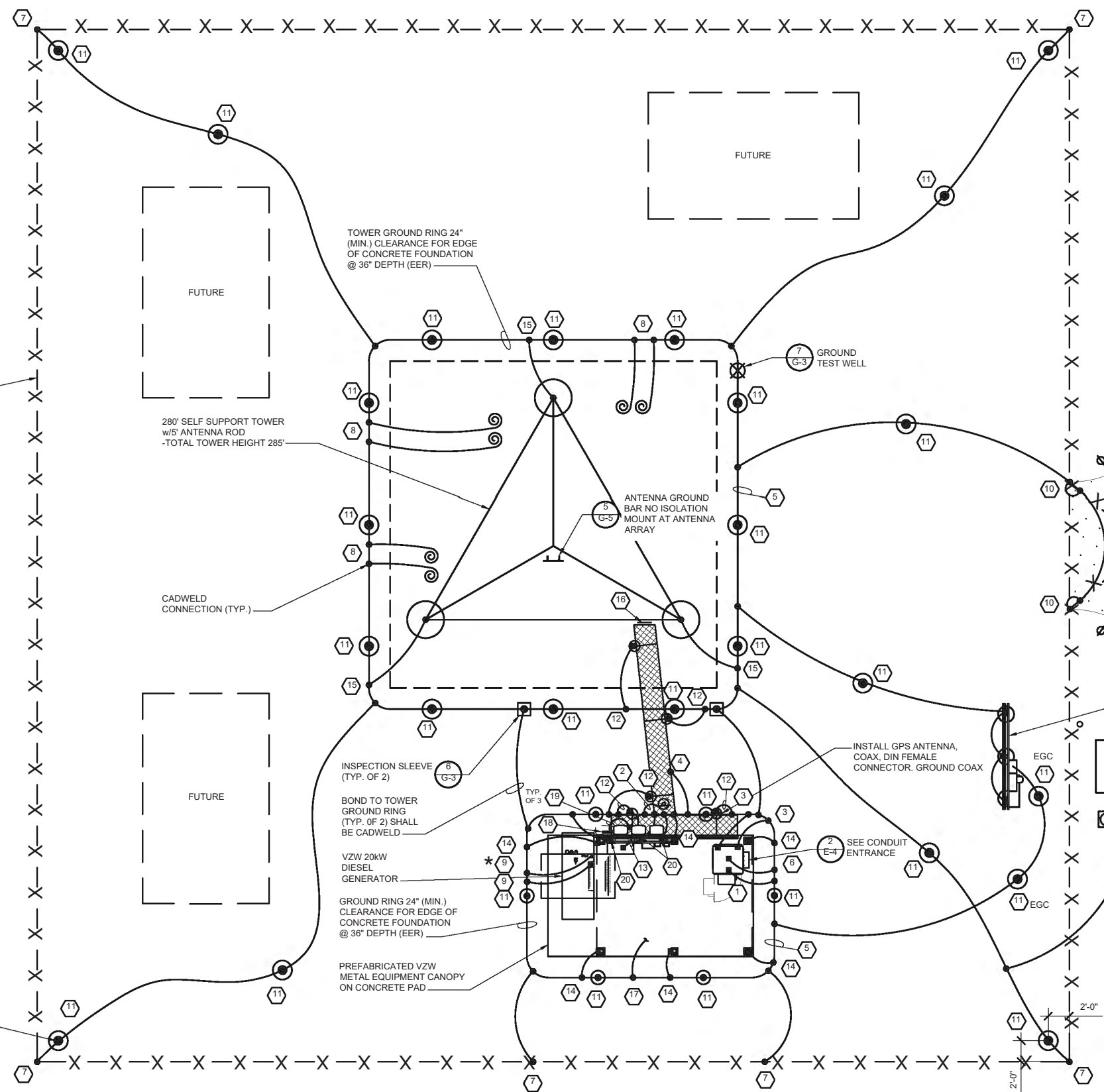

6'-0" TALL CHAIN LINK FENCE WITH 3 ROWS OF BARBED WIRE ATOP. - 7'-0" OVERALL HEIGHT

FUTURE

280' SELF SUPPORT TOWER w/5 ANTENNA ROD -TOTAL TOWER HEIGHT 285'

CADWELD CONNECTION (TYP.)

FUTURE

GROUND ROD 2'-0" CLEAR FROM FENCE (TYP. EACH CORNER)

TOWER GROUND RING 24" (MIN.) CLEARANCE FOR EDGE OF CONCRETE FOUNDATION @ 36" DEPTH (EER)

ANTENNA GROUND BAR NO ISOLATION MOUNT AT ANTENNA ARRAY

GROUND TEST WELL

INSPECTION SLEEVE (TYP. OF 2)

BOND TO TOWER GROUND RING (TYP. OF 2) SHALL BE CADWELD

VZW 20kW DIESEL GENERATOR

GROUND RING 24" (MIN.) CLEARANCE FOR EDGE OF CONCRETE FOUNDATION @ 36" DEPTH (EER)

PREFABRICATED VZW METAL EQUIPMENT CANOPY ON CONCRETE PAD

INSTALL GPS ANTENNA, COAX, DIN FEMALE CONNECTOR. GROUND COAX

SEE CONDUIT ENTRANCE

METER BOARD STRUCTURE GROUND 2 AWG BARE SOLID TINNED COPPER (TYPICAL OF EACH POST)

PIPE BOLLARD (TYP. OF 3)

PAD MOUNTED TRANSFORMER -FURNISHED & INSTALLED BY ELECTRIC PROVIDER -COORDINATE LOCATION WITH PROVIDER

FUTURE FIBER PEDESTAL & HAND HOLE BY FIBER PROVIDER

2 AWG BTSC FUTURE FIBER PEDESTAL GROUND (COIL UP 6' AT PEDESTAL LOCATION)

24"x36" VEHICLE RATED HAND HOLE FOR VERIZON WIRELESS ONLY FIBER SERVICE

TOWER GROUND RING NOTES:

1. GROUNDING PLAN SHOWN IS FOR A PAD AND PIER TOWER FOUNDATION. IF THE TOWER OWNER ELECTS TO INSTALL A CAISSON FOUNDATION THE TOWER GROUND RING (EER) WILL BE MODIFIED. THE TOWER GROUND RING (EER) SHALL BE INSTALLED PER VERIZON WIRELESS STANDARDS. 24" MIN. CLEARANCE FROM THE TOWER FOUNDATIONS AT 36" MIN. BELOW GRADE.
2. ALL GROUND RODS SHALL BE INSTALLED PER VERIZON WIRELESS STANDARDS.
3. ALL GROUND LEADS DEPICTED ON THIS PLAN SHALL BE MODIFIED TO CONNECT TO THE MODIFIED TOWER GROUND RING (EER) LOCATION.

- NOTES:**
1. ALL ABOVE GRADE GROUND LEADS TO BE INSTALLED IN 1/2" NON-CONDUCTIVE FLEXIBLE PVC CONDUIT WITH ANTI-THEFT COMPOUND.
 2. COORDINATE ICE BRIDGE POST GROUND LEAD INSTALLATION WITH ICE BRIDGE POST LOCATIONS ON SHEET S-1.
 3. SEE SHEET G-2 FOR GROUNDING KEYED NOTES.

GROUNDING SITE PLAN

SCALE: N.T.S.



GPD GROUP, INC.
 520 South Main Street, Suite 2531
 Akron, OH 44311
 330.572.2100 Fax: 330.572.2102

KENTUCKY RSA No. 1 PARTNERSHIP
Verizon Wireless
 d/b/a VERIZON WIRELESS
 250 E. 9TH STREET
 INDIANAPOLIS, INDIANA 46240

REVISION	DESCRIPTION
A	100% REVIEW FOR 90% REVIEW
B	100% REVIEW FOR 90% REVIEW
C	100% REVIEW FOR 90% REVIEW
D	100% REVIEW FOR 90% REVIEW
E	100% REVIEW FOR 90% REVIEW
F	100% REVIEW FOR 90% REVIEW
G	100% REVIEW FOR 90% REVIEW
H	100% REVIEW FOR 90% REVIEW
I	100% REVIEW FOR 90% REVIEW
J	100% REVIEW FOR 90% REVIEW
K	100% REVIEW FOR 90% REVIEW
L	100% REVIEW FOR 90% REVIEW
M	100% REVIEW FOR 90% REVIEW
N	100% REVIEW FOR 90% REVIEW
O	100% REVIEW FOR 90% REVIEW
P	100% REVIEW FOR 90% REVIEW
Q	100% REVIEW FOR 90% REVIEW
R	100% REVIEW FOR 90% REVIEW
S	100% REVIEW FOR 90% REVIEW
T	100% REVIEW FOR 90% REVIEW
U	100% REVIEW FOR 90% REVIEW
V	100% REVIEW FOR 90% REVIEW
W	100% REVIEW FOR 90% REVIEW
X	100% REVIEW FOR 90% REVIEW
Y	100% REVIEW FOR 90% REVIEW
Z	100% REVIEW FOR 90% REVIEW

STEVEN P. SCHAUB
 29008
 LICENSED PROFESSIONAL ENGINEER
 02/08/2019
 ELECTRICAL SEAL

EV BARLOW
 2557 STEVE DENTON ROAD
 BARLOW, KY 42024
GROUNDING SITE PLAN

ISSUED FOR:	
REVIEW	---
PERMIT	---
CONSTRUCTION	---
RECORD	---

PROJECT MANAGER	DESIGNER
TTP	DTC

JOB NO.
2017770.39

G-1

GROUNDING KEYED NOTES

- 1 BBG: FURN. & INST. 1 - 2/0 AWG INSULATED STRANDED COPPER GND. WIRE FOR BATTERY BAY GROUND (BBG) TO (EER). CONNECTION TO (EER) SHALL BE CADWELD. CONNECT THE 1 - 2/0 AWG INSULATED STRANDED COPPER GND. CONNECTION TO THE GROUND BAR IN THE BATTERY BAY SHALL BE MECHANICAL. ROUTE LEAD IN LIQUIDTIGHT FLEXIBLE NONMETALLIC CONDUIT w/ANTI-THEFT COMPOUND.
- 2 CEPSG: FURN. & INST. 1 - 2 AWG BARE SOLID TINNED COPPER GND. WIRE FOR CEPSG POST TO (EER). FURNISH & INSTALL THE THEFT DETERRENT GROUND POST ASSEMBLY PART #TDSGAPAC14 FOR THE COAX ENTRY PROTECTION SYSTEM (AS MFG'D. BY ERICO GROUNDING) TO THE POST. CONNECT THE 2 AWG BARE SOLID TINNED COPPER TO THE POST. THE CONNECTION TO POST SHALL BE CADWELD. REFER TO THE GENERAL INSTALLATION GUIDE AS SUPPLIED WITH THEFT DETERRENT POST MOUNT GROUND ASSEMBLY. SEE DETAIL 1 ON SHEET G-4 FOR DETAILS. CONNECTION (EER) SHALL BE CADWELD.
- 3 CG: FURN. & INST. 2 - 2 AWG BARE SOLID TINNED COPPER GND. WIRE FOR CABINET GROUND (CG) TO (EER). CONNECTION (EER) SHALL BE CADWELD. FURN. & INST. TWO HOLE LONG BARREL LUGS ON EXISTING 2 AWG BARE TINNED COPPER LEADS. VZW E.C. SHALL FURNISH & INSTALL DRAGON TOOTH WASHERS AND #8 STAINLESS STEEL FASTENERS ON ALL EQUIPMENT CABINET EXTERIOR GROUND LOCATIONS (TYP. 2 PER CABINET). REMOVE ALL SURFACE PAINT AND USE ANTIOXIDENT COMPOUND BETWEEN METAL AND WASHER. ALL LEADS SHALL BE DRESSED TO REDUCE TRIP HAZARDS. DETAIL 3 ON SHEET G-4 FOR DETAILS.
- 4 CSG: FURN. & INST. 1 - 2 AWG BARE SOLID TINNED COPPER GND WIRE FOR ICE BRIDGE CHANNEL TO (EER). CONNECTION (EER) AND ICE BRIDGE CHANNEL SHALL BE CADWELD.
- 5 EER: FURN. & INST. 2 AWG BARE SOLID TINNED COPPER BURIED EXTERIOR ELECTRODE GROUND RING (EER) AROUND RADIO EQUIPMENT PAD AND TOWER BURIED AT 36" OR 6" BELOW FROST LINE (WHICHEVER IS GREATER). MAINTAIN 24" FROM EQUIPMENT PAD AND TOWER FOUNDATIONS MINIMUM.
- 6 FEG: FURN. & INST. 1 - 2 AWG BARE SOLID TINNED COPPER GND. WIRE FOR FIBER ENTRANCE GROUND (FEG) TO (TGE). RUN INTO THE POWER PLANT CABINET AND MAKE A MECHANICAL CONNECTION TO THE FIBER SERVICE GROUND POINT. ROUTE LEAD IN GALV. FLEXIBLE METALLIC CONDUIT CRIMPED TO LEAD AT 6" O.C. CONNECTION TO (EER) SHALL BE CADWELD.
- 7 FG: FURN. & INST. 1 - 2 AWG BARE SOLID TINNED COPPER GND WIRE FROM NEW FENCING TO GROUND RING (EER). CONNECTION TO FENCING SHALL BE AT THE BASE OF FENCE POST USING CADWELD AND WEAVE GND. WIRE THRU FABRIC AND ATTACH TO TOP RAIL WITH CADWELD. CONNECTION TO (EER) SHALL BE CADWELD.
- 8 FTWGL: FURN. & INST. FUTURE TOWER WAVEGUIDE GROUND BAR LEADS. CONTRACTOR SHALL COIL UP TEN (10') OF 2 AWG SOLID TINNED COPPER GROUND (TYP.)
- 9 GEG: FURN. & INST. 1 - 2 AWG BARE SOLID TINNED COPPER GND. WIRE FOR THE GENERATOR ENCLOSURE TO (EER). CONNECTION TO GENERATOR ENCLOSURE SHALL BE MECHANICAL. ROUTE LEAD IN FLEXIBLE NONMETALLIC CONDUIT w/ANTI-THEFT COMPOUND. *GENERATOR SERVICE GROUND WHERE REQUIRED BY JURISDICTION HAVING AUTHORITY
- 10 GG: FURN. & INST. 1 - 2 AWG BARE SOLID TINNED COPPER GND WIRE AT EACH GATE POST AND PROVIDE GROUND WIRE TO BONDING JUMPER FROM GATE POST TO FENCE POST.
- 11 GRE: FURN. & INST. GROUND RODS TO 36" BELOW FINISH GRADE (OR 6" BELOW FROST LINE, WHICHEVER IS GREATER) AT A MINIMUM SPACING OF 10'-0" AT RADIO EQUIPMENT PAD GROUND SYSTEM. CONNECTION TO (EER) SHALL BE CADWELD.
- 12 IBSG: FURN. & INST. 1 - 2 AWG BARE SOLID TINNED COPPER GND. WIRE FROM ICE BRIDGE SUPPORT POST TO (EER). CONNECTION TO (EER) & ICE BRIDGE SUPPORT POST SHALL BE CADWELD. SEE SHEET S-1 FOR ICE BRIDGE POST LOCATIONS.
- 13 PEG: FURN. & INST. 1 - 2 AWG BARE SOLID TINNED COPPER GND. WIRE FOR THE 'ILC' GROUND BAR TO (EER). CONNECT 1 - 2 AWG BARE SOLID TINNED COPPER GND WIRE FOR THE POWER ENTRANCE GROUND (PEG). CONNECTION OF THE WIRE TO THE INTEGRATED LOAD CENTER GROUND BAR SHALL BE MECHANICAL. ROUTE LEAD IN FLEXIBLE NONMETALLIC CONDUIT w/ANTI-THEFT COMPOUND. CONNECTION (EER) SHALL BE CADWELD.
- 14 PCSG: FURN. & INST. 1 - 2 AWG BARE SOLID TINNED COPPER GND. WIRE FOR THE PAD CANOPY SUPPORT BASE TO (EER). CONNECT SOLID TINNED COPPER ONE HOLE GROUND TAB. WITH AN EXOTHERMIC CONNECTION. THE CONNECTION OF THE GROUND WIRE AND LUG TO THE CANOPY SUPPORT BASE SHALL BE MECHANICAL. SEE DETAIL 3 ON SHEET G-3. ROUTE LEAD IN FLEXIBLE NONMETALLIC CONDUIT w/ANTI-THEFT COMPOUND. CONNECTION (EER) SHALL BE CADWELD.
- 15 TBG: FURN. & INST. 1 - 2 AWG BARE SOLID TINNED COPPER GND. WIRE FROM TOWER LEG BASE PLATE TO (EER). CONNECTION TO TOWER LEG BASE PLATE SHALL BE CADWELD OR MECHANICAL TO LEG AND (EER) SHALL BE CADWELD.
- 16 TWG: FURN. & INST. THEFT DETERRENT GROUND ASSEMBLY KIT PART #TDSGABC14 FOR THE TOWER WAVEGUIDE GROUND (TWG) DIRECTLY TO THE TOWER (SEE SITE SPECIFIC GROUNDING PLAN OF DESIGN DRAWINGS).
- 17 UG: FURN. & INST. 1 - 2 AWG BARE SOLID TINNED COPPER GND. WIRE (UFER GROUND) FOR PAD FOUNDATION REINFORCEMENT STEEL CONNECTION TO (EER) SHALL BE CADWELD. PROVIDE HEAT SHRINK TUBING OR ELECTRICAL TAPE PROTECTION FOR CONDUCTOR AT TRANSITION BETWEEN CONCRETE AND SOIL.
- 18 OGA: VZW E.C. SHALL FURN. & INST. THE THEFT DETERRENT GROUND ASSEMBLY KIT PART #TDSGAPC14 FOR THE OVP GROUND (OGL) DIRECTLY TO THE OVP H-FRAME POST. SEE DETAIL 4 ON SHEET G-4.
- 19 OGL: FURN. & INST. 1 - 6 AWG GREEN INSULATED STRANDED COPPER GND. WIRE FROM OVP GROUND POINT TO OVP GROUND ASSEMBLY (OGA). CONNECTION TO GROUND BAR SHALL BE MECHANICAL.
- 20 OHG: FURN. & INST. 1 - 2 AWG BARE SOLID TINNED COPPER GND. WIRE FOR THE 'OVP' H-FRAME TO (EER). (TYP. OF 3.) CONNECTION (EER) SHALL BE CADWELD.

GROUNDING NOTES

1. ALL UNDERGROUND CONNECTIONS ON THE LIGHTNING PROTECTION SYSTEM SHALL BE EXOTHERMIC WELDED USING THE CADWELD PROCESS. THE VERIZON WIRELESS E.C. SHALL FURN. & INST. ALL THESE CONNECTIONS, INCLUDING WELD METALS, MOLDS AND TOOLS. THE VERIZON WIRELESS E.C. SHALL FURN. & INST. 5/8" x 10' COPPER CLAD STEEL (COPPER JACKET 0.0012" MIN.) GROUND RODS, DRIVEN VERTICAL TO 36" BELOW FIN. GRADE (OR 6" BELOW FROSTLINE, WHICHEVER IS GREATER) @ 10'-0" O.C. MINIMUM.
2. THE E.C. SHALL FURN. & INST. 2 AWG BARE SOLID TINNED COPPER GND. WIRE AT A DEPTH OF 36" BELOW FIN. GRADE FOR THE TOWER AND EQUIPMENT PAD (EER) AND ICE BRIDGE (CSG).
3. ALL EXTERIOR GND. CONNECTIONS SHALL BE EXOTHERMIC CADWELD (U.N.O).
4. UPON COMPLETION OF THE EQUIPMENT PAD GROUNDING RING AND BEFORE BONDING TO THE TOWER GROUND RING, THE VERIZON WIRELESS E.C. SHALL MEGGER TEST THIS GROUNDING FIELD. THE REQUIRED RESISTANCE LEVEL IS 5 OHMS OR LESS. THE VERIZON WIRELESS E.C. SHALL NOTIFY THE ENGINEER IF THESE REQUIREMENTS ARE NOT ACHIEVED. THE VERIZON WIRELESS E.C. SHALL SUBMIT PRICING TO VERIZON WIRELESS FOR THE INSTALLATION OF ADDITIONAL GROUND RODS REQUIRED FOR PROPER RESISTANCE. UPON APPROVAL FROM VERIZON WIRELESS, THE VERIZON WIRELESS E.C. SHALL INSTALL ADDITIONAL GROUND RODS AS REQUIRED. AFTER PASSING TEST, THE VERIZON WIRELESS E.C. SHALL BOND THE EQUIPMENT PAD RING TO THE TOWER RING. THE VERIZON WIRELESS E.C. SHALL NOTIFY VERIZON WIRELESS CONSTRUCTION MANAGER 48 HOURS PRIOR TO BACKFILLING TRENCHES, POURING CONCRETE FOR FOUNDATIONS, TO INSPECT BONDS AND INSPECT ANY/ALL BREAKS AND REPAIRS TO THE GROUND RING.
5. GROUND SYSTEM SHALL BE VISUALLY INSPECTED BY A VERIZON WIRELESS CONSTRUCTION ENGINEER BEFORE BACKFILLING IF REQUESTED.
6. NO SHARP 90° BENDS SHALL BE USED. A LONG SWINGING RADIUS BEND REQUIRED.
7. ALL EQUIPMENT PAD AND EQUIPMENT GROUNDING SHALL BE IN ACCORDANCE WITH VERIZON WIRELESS SPECIFICATIONS.
8. ALL ABOVE GROUND BARE COPPER CONDUCTORS BELOW 10' ABOVE GRADE SHALL BE INSTALLED IN FLEXIBLE PVC CONDUIT. CONDUIT SHALL BE FILLED WITH THEFT DETERRENT COMPOUND (ELECTRIC MOTION COMPANY ANTI-THEFT COMPOUND EM-5101).
9. BARE COPPER CONDUCTORS SHALL NOT BE INSTALLED WHERE THEY MAY BE IN CONTACT WITH GALVANIZED METALS. THE CONDUCTORS SHALL BE INSULATED OR ENCLOSED IN PVC CONDUIT, PLASTIC SEALTIGHT OR INSTALLED WITH STANDOFF SUCH THAT NO CONTACT BETWEEN DISSIMILAR METALS MAY TAKE PLACE.
10. CONNECTION OF COPPER CONDUCTORS TO GALVANIZED METAL OR ALUMINUM SHALL BE AVOIDED. BRASS OR STAINLESS STEEL LUGS OR BARS SHALL BE USED FOR THESE CONNECTIONS.
11. ALL CRIMP LUG CONNECTIONS TO ALL GROUND BARS SHALL BE LUBRICATED WITH A CORROSION INHIBITOR ("OXY-GREASE") OR APPROVED EQUAL.
12. GROUND ASSEMBLIES SHALL BE THEFT DETERRENT DESIGN AS MANUFACTURED BY ERICO INC. AND FURNISHED BY VERIZON WIRELESS. PROVIDE TWO (2) LUG HOLES PER VERIZON WIRELESS STANDARDS. UNLESS NOTED OTHERWISE.

LEGEND

BBG	BATTERY BAY GROUND
CEPSG	COAX ENTRY PROTECTION SYSTEM GROUND
CG	CABINET GROUND
CSG	CABLE SUPPORT GROUND
EER	BURIED EXTERIOR ELECTRODE GROUND RING
EGC	EQUIPMENT GROUNDING CONDUCTOR (NEC DESIGNATION)
FEG	FIBER ENTRANCE GROUND
FG	FENCE GROUND
FTWGL	FUTURE TOWER WAVEGUIDE GROUND LEAD
GEC	GROUNDING ELECTRODE CONDUCTOR (NEC DESIGNATION)
GEG	GENERATOR ENCLOSURE GROUND
GES	GROUNDING ELECTRODE SYSTEM (NEC DESIGNATION)
GG	GATE GROUND
GRE	GROUND ROD ELECTRODE
IBSG	ICE BRIDGE SUPPORT GROUND
OGA	OVP GROUND ASSEMBLY
OGL	OVP GROUND LEAD
OHG	OVP H-FRAME SUPPORT GROUND
PEG	POWER ENTRANCE GROUND
PCSG	PAD CANOPY SUPPORT GROUND DOWN LEAD
TBG	TOWER BASE GROUND
TWG	TOWER WAVEGUIDE GROUND ASSEMBLY
UG	UFER GROUND (PIER FOUNDATION)
	CABLE TO CABLE CADWELD CONNECTION
	CABLE TO GND. ROD CADWELD CONNECTION
	TEST WELL
	INSPECTION PORT CABLE TO CABLE CADWELD CONNECTION



REVISION	DATE	DESCRIPTION	BY
A	01/28/19	ISSUED FOR 90% REVIEW	
B	01/28/19	ISSUED DISTANCE TO HOUSE	
C	01/24/19	ISSUED CALL OUTS AND REVISED SHEET TITLE	
D	02/08/19	FINAL CONSTRUCTION DRAWINGS	

STEVEN P. SCHAUB
29008
LICENSED PROFESSIONAL ENGINEER
02/08/2019
ELECTRICAL SEAL

EV BARLOW
2557 STEVE DENTON ROAD
BARLOW, KY 42024

GROUNDING NOTES

ISSUED FOR:	
REVIEW	---
PERMIT	---
CONSTRUCTION	---
RECORD	---

PROJECT MANAGER	DESIGNER
TTP	DTC

JOB NO.
2017770.39

G-2

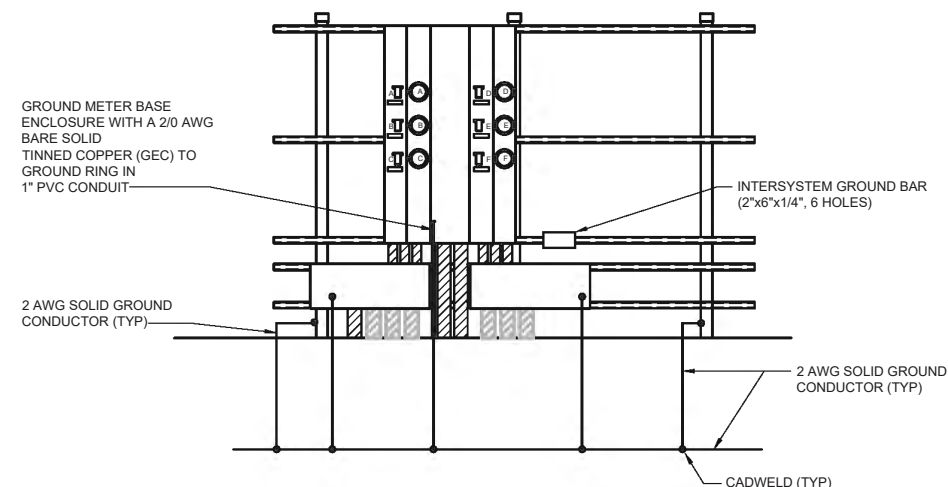

METER BOARD STRUCTURE GROUNDING

SCALE: 1/4" = 1'-0"

1
G-3

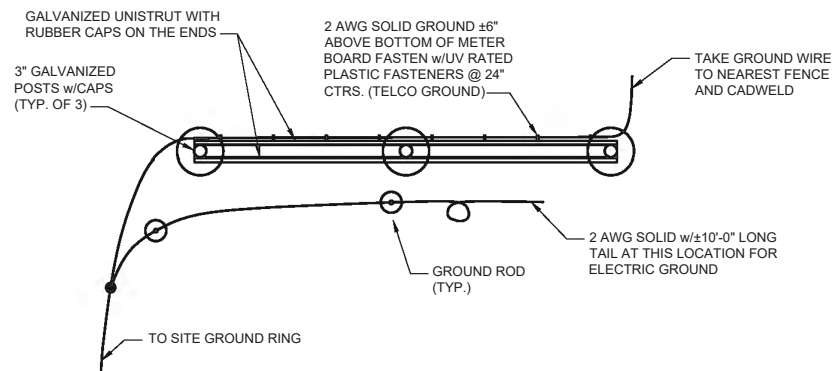

METER BOARD STRUCTURE GROUND PLAN

SCALE: N.T.S.

2
G-3

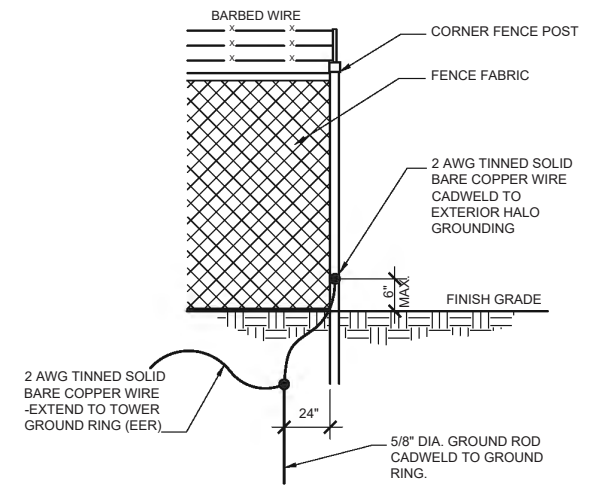

FENCE GROUNDING DETAIL

SCALE: N.T.S.

3
G-3

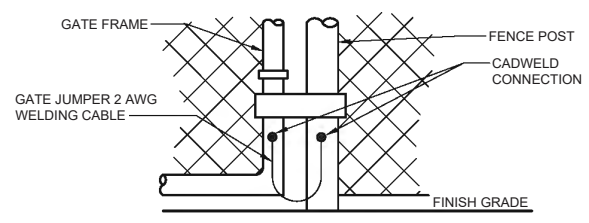

GATE GROUNDING DETAIL

SCALE: N.T.S.

4
G-3

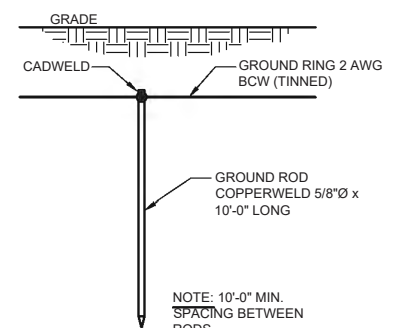

GROUND ROD DETAIL

SCALE: N.T.S.
(TYP. FOR CONTRACTOR AND GC)

5
G-3

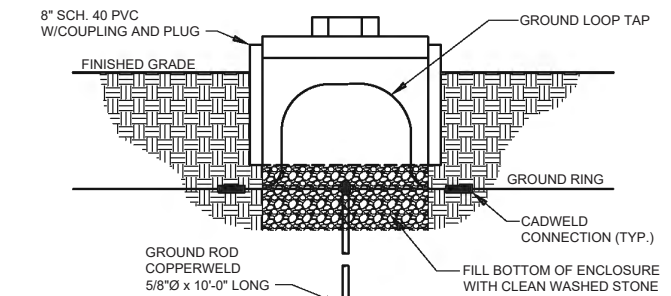

GROUND TEST WELL DETAIL

SCALE: N.T.S.

7
G-3

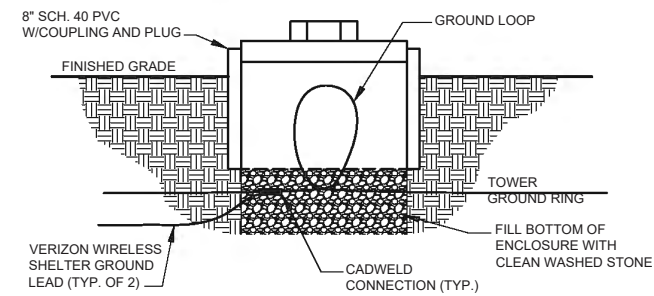

INSPECTION SLEEVE DETAIL

SCALE: N.T.S.

6
G-3

GPD GROUP, INC.
520 South Main Street, Suite 2531
Akron, OH 44311
330.572.2100 Fax: 330.572.2102

KENTUCKY RSA No. 1 PARTNERSHIP
d/b/a Verizon Wireless
250 E. 9TH STREET
INDIANAPOLIS, INDIANA 46240

REVISION	DESCRIPTION
A	REVISED FOR 90% REVIEW
B	REVISED DISTANCE TO HOUSE
C	REVISED BUILDING CALL OUTS AND REVISED SHEET TITLE
D	REVISED FINISH CONSTRUCTION DRAWINGS

STATE OF KENTUCKY
STEVEN P. SCHAUB
29008
LICENSED PROFESSIONAL ENGINEER
02/08/2019
ELECTRICAL SEAL

EV BARLOW
2557 STEVE DENTON ROAD
BARLOW, KY 42024

GROUNDING DETAILS

ISSUED FOR:	
REVIEW	---
PERMIT	---
CONSTRUCTION	---
RECORD	---

PROJECT MANAGER	DESIGNER
TTP	DTC

JOB NO.
2017770.39

G-3

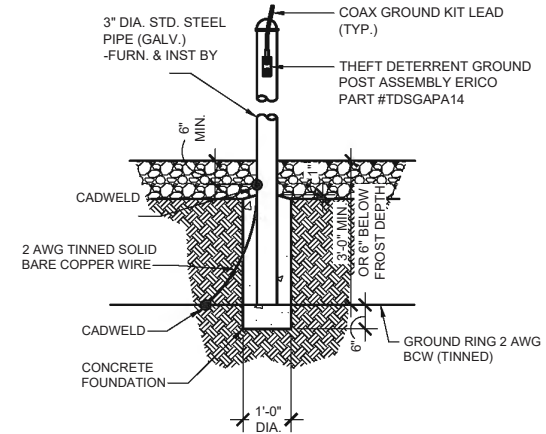

**THEFT DETERRENT POST MOUNT
GROUND DETAIL (CEPSG)**

SCALE: N.T.S.
(BY GC)

1
G-4

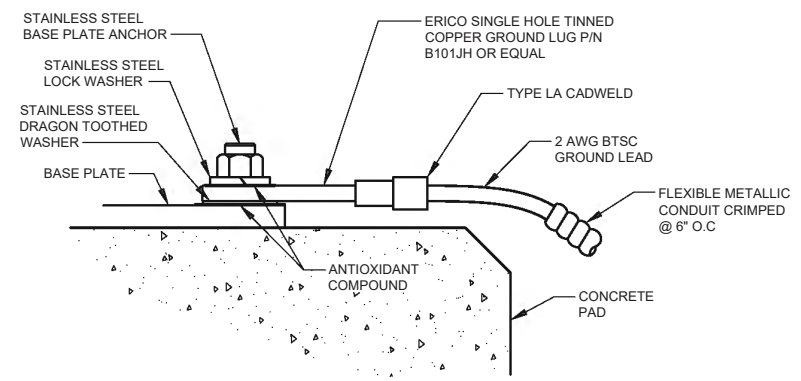

1. ALL HARDWARE SHALL BE 18-8 STAINLESS STEEL.
2. INSTALL ANCHOR LENGTH TO ALLOW EXPOSURE OF AT LEAST TWO THREADS.
3. AT CONNECTIONS MADE TO STEEL OR ANY OTHER DISSIMILAR METALS, A DRAGON TOOTH WASHER SHALL BE USED BETWEEN THE CONNECTOR AND METAL.
4. IF NO DRAGON TOOTH WASHER IS USED, THOROUGHLY REMOVE A SECTION OF THE COATING APPROXIMATELY THE SIZE OF THE CONNECTOR WITH AN ABRASIVE STYLE TOOL.
5. No-Ox-ID ANTI-OXIDATION COMPOUND (SANCHEM) SHALL BE USED AT ALL COPPER TO COPPER CONNECTIONS.
6. A ZINC BASED (GRAY COLORED) ANTI-OXIDATION COMPOUND SHALL BE USED AT ALL COPPER TO STEEL CONNECTIONS.
7. PENTROX OR EQUAL ANTI-OXIDATION COMPOUND SHALL BE USED AT ALL COPPER TO ALUMINUM CONNECTIONS.

**GROUND LUG TO BASEPLATE
INSTALLATION DETAIL**

SCALE: N.T.S.

3
G-4

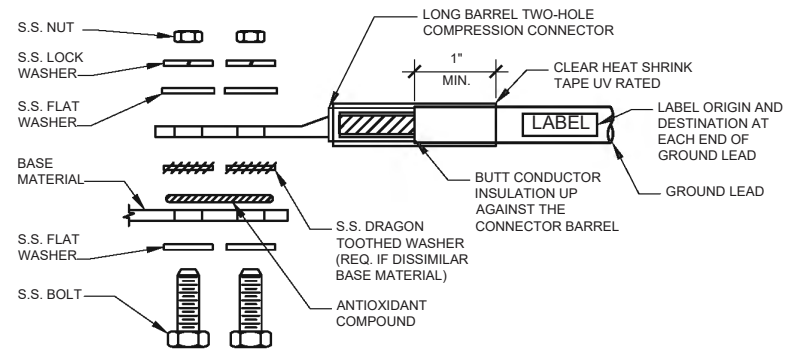

1. ALL HARDWARE SHALL BE 18-8 STAINLESS STEEL.
2. CHOOSE BOLT LENGTH TO ALLOW EXPOSURE OF AT LEAST TWO THREADS.
3. BACK TO BACK LUG CONNECTIONS ARE ACCEPTABLE WHEN BONDED TO A GROUND BAR OR STEEL OBJECT.
4. AT CONNECTIONS MADE TO STEEL OR ANY OTHER DISSIMILAR METALS, A DRAGON TOOTH WASHER SHALL BE USED BETWEEN THE CONNECTOR AND METAL.
5. IF NO DRAGON TOOTH WASHER IS USED, THOROUGHLY REMOVE A SECTION OF THE COATING APPROXIMATELY THE SIZE OF THE CONNECTOR WITH AN ABRASIVE STYLE TOOL.
6. No-Ox-ID ANTI-OXIDATION COMPOUND (SANCHEM) SHALL BE USED AT ALL COPPER TO COPPER CONNECTIONS.
7. A ZINC BASED (GRAY COLORED) ANTI-OXIDATION COMPOUND SHALL BE USED AT ALL COPPER TO STEEL CONNECTIONS.
8. PENTROX OR EQUAL ANTI-OXIDATION COMPOUND SHALL BE USED AT ALL COPPER TO ALUMINUM CONNECTIONS.

GROUND LUG INSTALLATION DETAIL

SCALE: N.T.S.

2
G-4

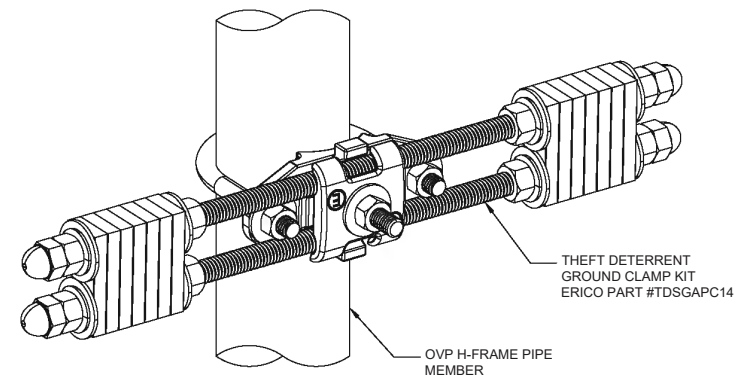

OVP GROUND ASSEMBLY (OGA)

SCALE: N.T.S.
(BY GC)

4
G-4

KENTUCKY RSA No. 1 PARTNERSHIP
Verizon Wireless
d/b/a VERIZON WIRELESS
250 E. 9TH STREET
INDIANAPOLIS, INDIANA 46240

REVISION	DESCRIPTION
A	ISSUED FOR 90% REVIEW
B	ISSUED FOR 100% REVIEW
C	ISSUED FOR 100% REVIEW
D	ISSUED FOR 100% REVIEW
E	ISSUED FOR 100% REVIEW
F	ISSUED FOR 100% REVIEW
G	ISSUED FOR 100% REVIEW
H	ISSUED FOR 100% REVIEW
I	ISSUED FOR 100% REVIEW
J	ISSUED FOR 100% REVIEW
K	ISSUED FOR 100% REVIEW
L	ISSUED FOR 100% REVIEW
M	ISSUED FOR 100% REVIEW
N	ISSUED FOR 100% REVIEW
O	ISSUED FOR 100% REVIEW
P	ISSUED FOR 100% REVIEW
Q	ISSUED FOR 100% REVIEW
R	ISSUED FOR 100% REVIEW
S	ISSUED FOR 100% REVIEW
T	ISSUED FOR 100% REVIEW
U	ISSUED FOR 100% REVIEW
V	ISSUED FOR 100% REVIEW
W	ISSUED FOR 100% REVIEW
X	ISSUED FOR 100% REVIEW
Y	ISSUED FOR 100% REVIEW
Z	ISSUED FOR 100% REVIEW

STEVEN P. SCHAUB
29008
LICENSED PROFESSIONAL ENGINEER
02/08/2019
ELECTRICAL SEAL

EV BARLOW
2557 STEVE DENTON ROAD
BARLOW, KY 42024

GROUNDING DETAILS

ISSUED FOR:	
REVIEW	---
PERMIT	---
CONSTRUCTION	---
RECORD	---

PROJECT MANAGER	DESIGNER
TTP	DTC

JOB NO.
2017770.39

G-4

KENTUCKY RSA No. 1 PARTNERSHIP
 d/b/a Verizon Wireless
 250 E. 9TH STREET
 INDIANAPOLIS, INDIANA 46240

REVISION	DESCRIPTION
A	ISSUED FOR 90% REVIEW
B	ISSUED FOR 100% REVIEW
C	ISSUED FOR DISTANCE TO HOUSE
D	ISSUED FOR BUILDING CALL OUTS AND REVISED SHEET TITLE
E	ISSUED FOR CONSTRUCTION DRAWINGS
F	ISSUED FOR FINAL

STATE OF KENTUCKY
STEVEN P. SCHAUB
 29008
 LICENSED PROFESSIONAL ENGINEER
 02/08/2019
 ELECTRICAL SEAL

EV BARLOW
 2557 STEVE DENTON ROAD
 BARLOW, KY 42024
GROUNDING DETAILS

ISSUED FOR:	
REVIEW	---
PERMIT	---
CONSTRUCTION	---
RECORD	---

PROJECT MANAGER	DESIGNER
TTP	DTC

JOB NO.
2017770.39

G-5

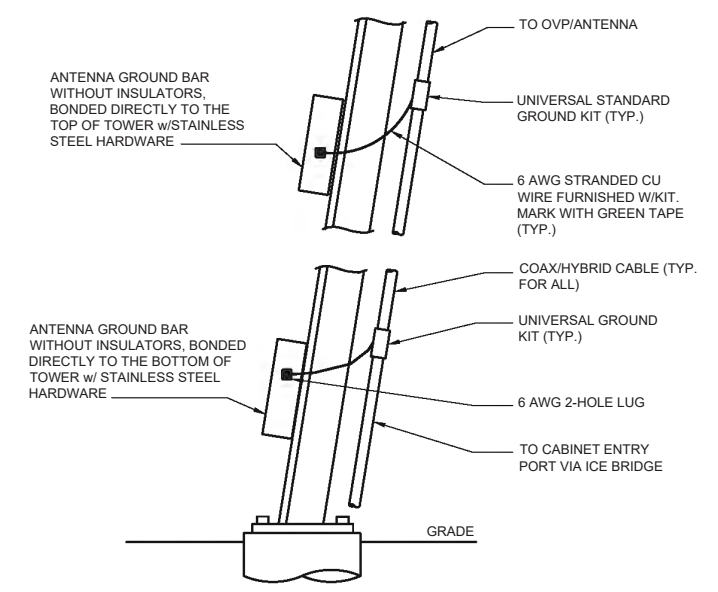
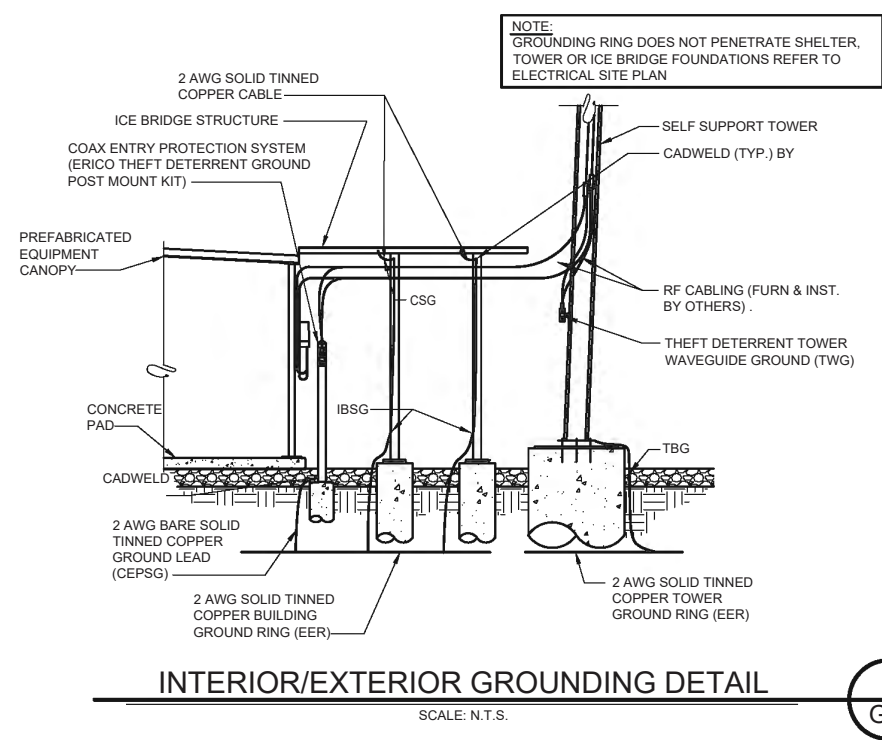

ANTENNA CABLE GROUNDING INSTALLATION DETAIL
 SCALE: N.T.S.

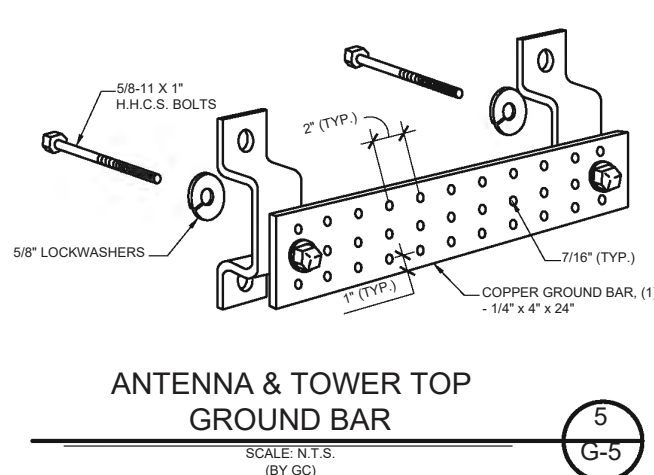
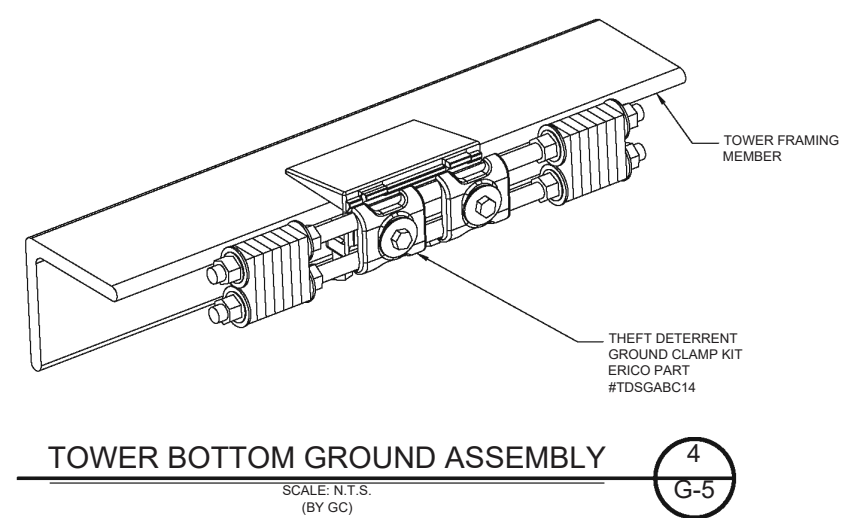
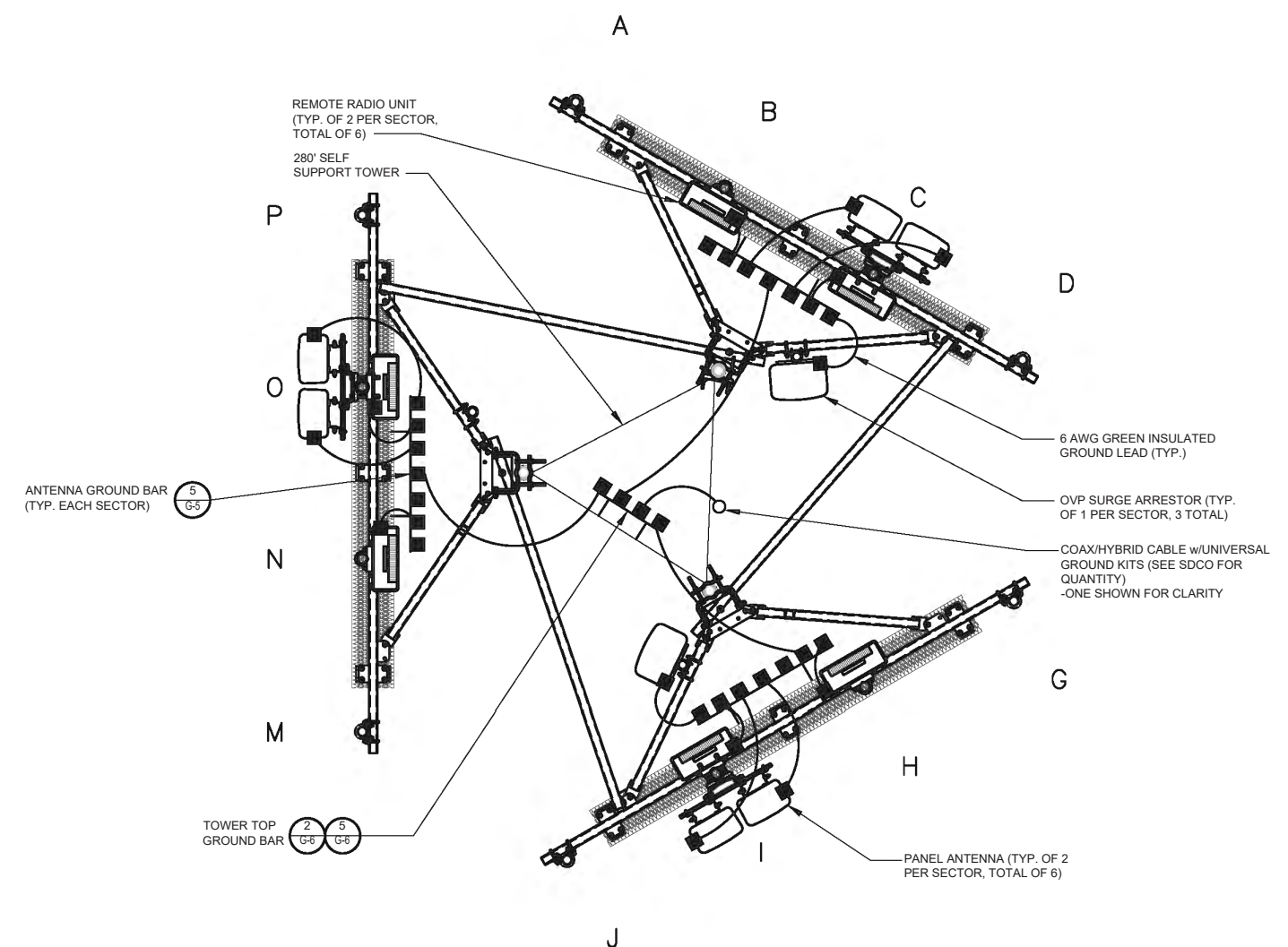

Drawing Name: O:\2017\201777038\EV Barlow\AEC\DEV Barlow CD.dwg
February 8, 2019 2:8 PM - skrschmer

REV.	DATE	DESCRIPTION
A	10/31/18	ISSUED FOR 90% REVIEW
B	01/22/19	ADDED DISTANCE TO HOUSE
C	01/24/19	ADDED BUILDING CALL OUTS AND REVISED SHEET TITLE
D	02/08/19	FINAL CONSTRUCTION DRAWINGS

REFERENCE ONLY

EV BARLOW
2557 STEVE DENTON ROAD
BARLOW, KY 42024

ANTENNA PLAN AND DETAILS (REFERENCE ONLY)

ISSUED FOR:	
REVIEW	--
PERMIT	--
CONSTRUCTION	--
RECORD	--

PROJECT MANAGER	DESIGNER
TTP	DTC

JOB NO.
2017770.39

RF-1

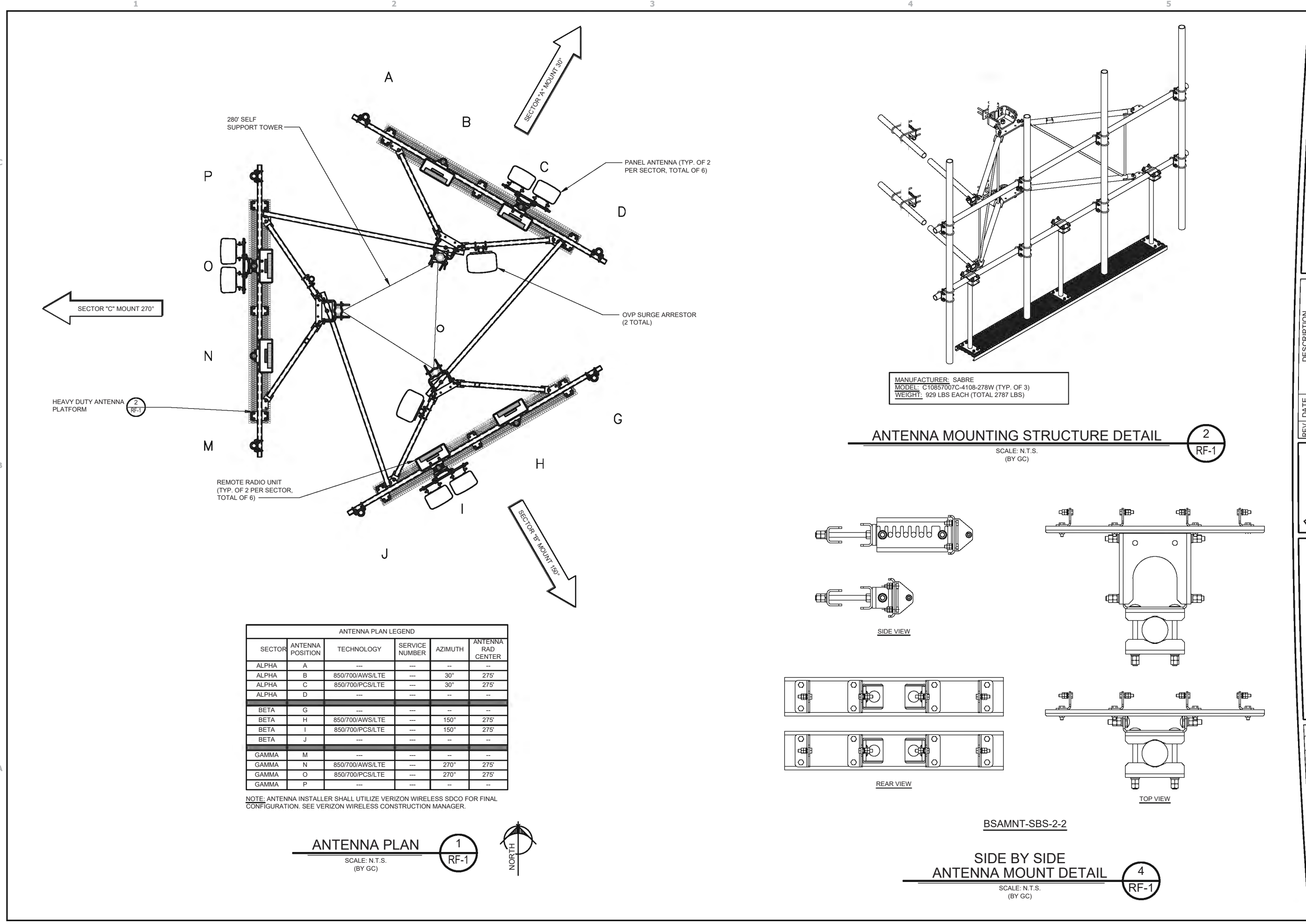

ANTENNA PLAN LEGEND					
SECTOR	ANTENNA POSITION	TECHNOLOGY	SERVICE NUMBER	AZIMUTH	ANTENNA RAD CENTER
ALPHA	A	--	--	--	--
ALPHA	B	850/700/AWS/LTE	--	30°	275'
ALPHA	C	850/700/PCS/LTE	--	30°	275'
ALPHA	D	--	--	--	--
BETA	G	--	--	--	--
BETA	H	850/700/AWS/LTE	--	150°	275'
BETA	I	850/700/PCS/LTE	--	150°	275'
BETA	J	--	--	--	--
GAMMA	M	--	--	--	--
GAMMA	N	850/700/AWS/LTE	--	270°	275'
GAMMA	O	850/700/PCS/LTE	--	270°	275'
GAMMA	P	--	--	--	--

NOTE: ANTENNA INSTALLER SHALL UTILIZE VERIZON WIRELESS SDCO FOR FINAL CONFIGURATION. SEE VERIZON WIRELESS CONSTRUCTION MANAGER.

ANTENNA PLAN
SCALE: N.T.S.
(BY GC)

1
RF-1



ANTENNA MOUNTING STRUCTURE DETAIL

SCALE: N.T.S.
(BY GC)

2
RF-1

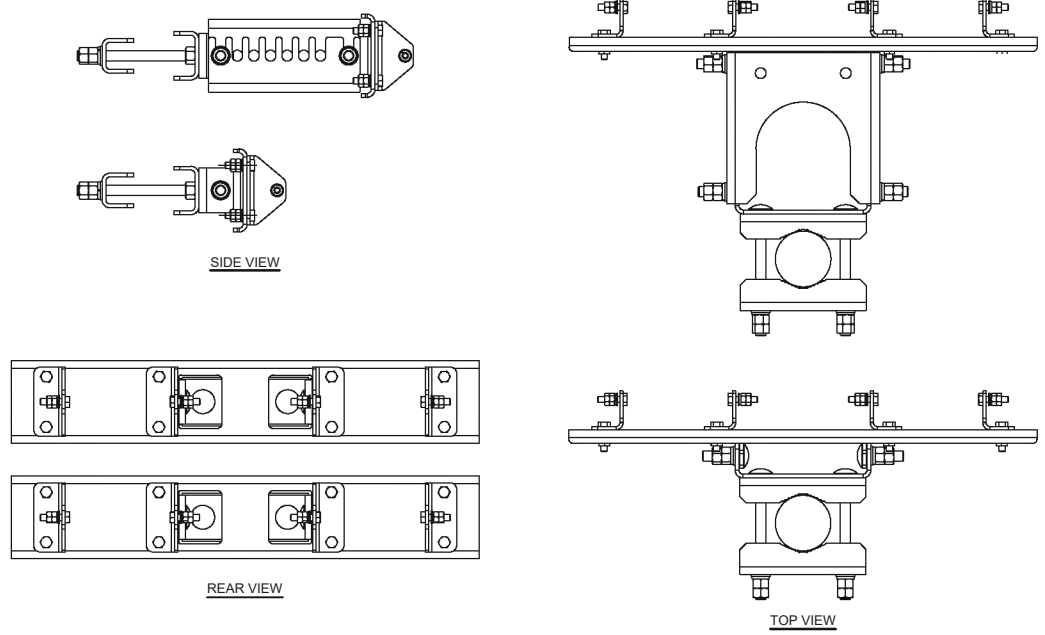

BSAMNT-SBS-2-2

SIDE BY SIDE ANTENNA MOUNT DETAIL

SCALE: N.T.S.
(BY GC)

4
RF-1

Drawing Name: O:\2017\201777038\EV Barlow\AEC\DEV Barlow CD.dwg
February 8, 2019 2:8 PM - skrschneer

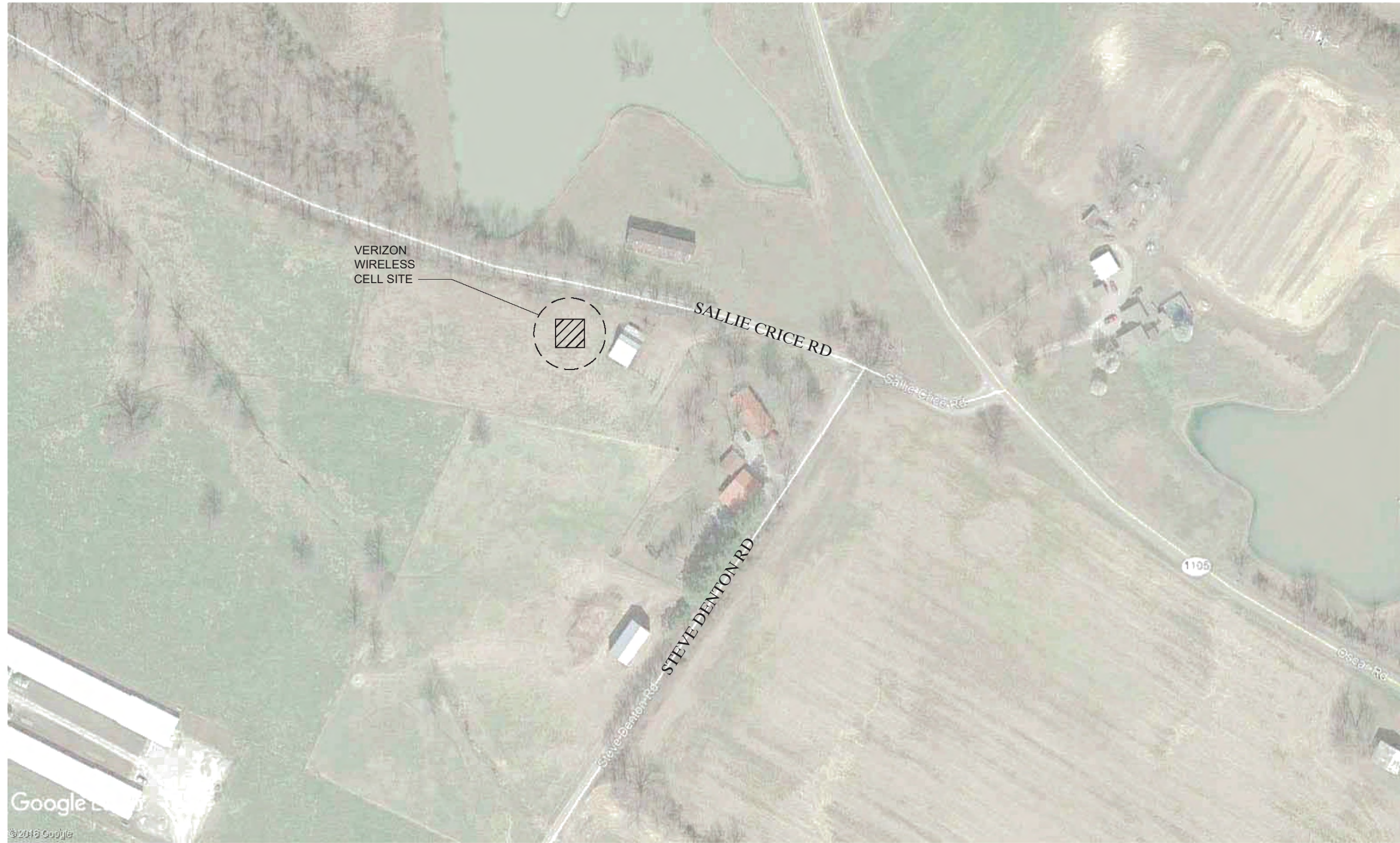

VERIZON WIRELESS
 SITE NAME: EV BARLOW - B
 SITE ADDRESS: XXXX STEVE DENTON RD
 BARLOW, KY 42024
 SITE EMIS#: 616190973
 SITE COORDINATES: 37°06'42.15" N, 89°02'44.58" W

VERIZON WIRELESS TIER II SITE MAP
 SCALE: N.T.S.



GPD GROUP, INC.
 520 South Main Street, Suite 2531
 Akron, OH 44311
 330.572.2100 Fax: 330.572.2102

KENTUCKY RSA No. 1 PARTNERSHIP
 d/b/a VERIZON WIRELESS

 255 S. MAIN STREET
 INDIANAPOLIS, INDIANA 46240

REV	DATE	DESCRIPTION
A	10/31/18	ISSUED FOR 90% REVIEW
B	01/22/19	ADDED DISTANCE TO HOUSE
C	01/24/19	ADDED BUILDING CALL OUTS AND REVISED SHEET TITLE
D	02/08/19	FINAL CONSTRUCTION DRAWINGS

REFERENCE ONLY

EV BARLOW
 2557 STEVE DENTON ROAD
 BARLOW, KY 42024
**EMERGENCY RESPONSE
 TIER II SITE MAP
 (REFERENCE ONLY)**

ISSUED FOR:	
REVIEW	--
PERMIT	--
CONSTRUCTION	--
RECORD	--

PROJECT MANAGER	DESIGNER
TTP	DTC

JOB NO.
2017770.39

ER-1

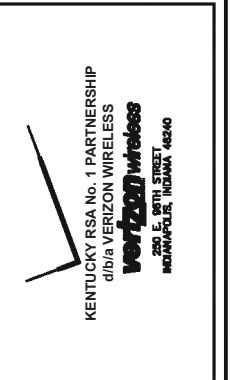

REV.	DATE	DESCRIPTION
A	10/31/18	ISSUED FOR 90% REVIEW
B	01/22/19	ADDED DISTANCE TO HOUSE
C	01/24/19	ADDED BUILDING CALL OUTS AND REVISED SHEET TITLE
D	02/08/19	FINAL CONSTRUCTION DRAWINGS

REFERENCE ONLY

EV BARLOW
 2557 STEVE DENTON ROAD
 BARLOW, KY 42024

EMERGENCY RESPONSE TIER II
 VERIZON WIRELESS EQUIPMENT PLAN
 (REFERENCE ONLY)

ISSUED FOR:	
REVIEW	--
PERMIT	--
CONSTRUCTION	--
RECORD	--

PROJECT MANAGER	DESIGNER
TTP	DTC

JOB NO.
2017770.39

ER-2

SALLIE CRICE RD

STEVE DENTON RD

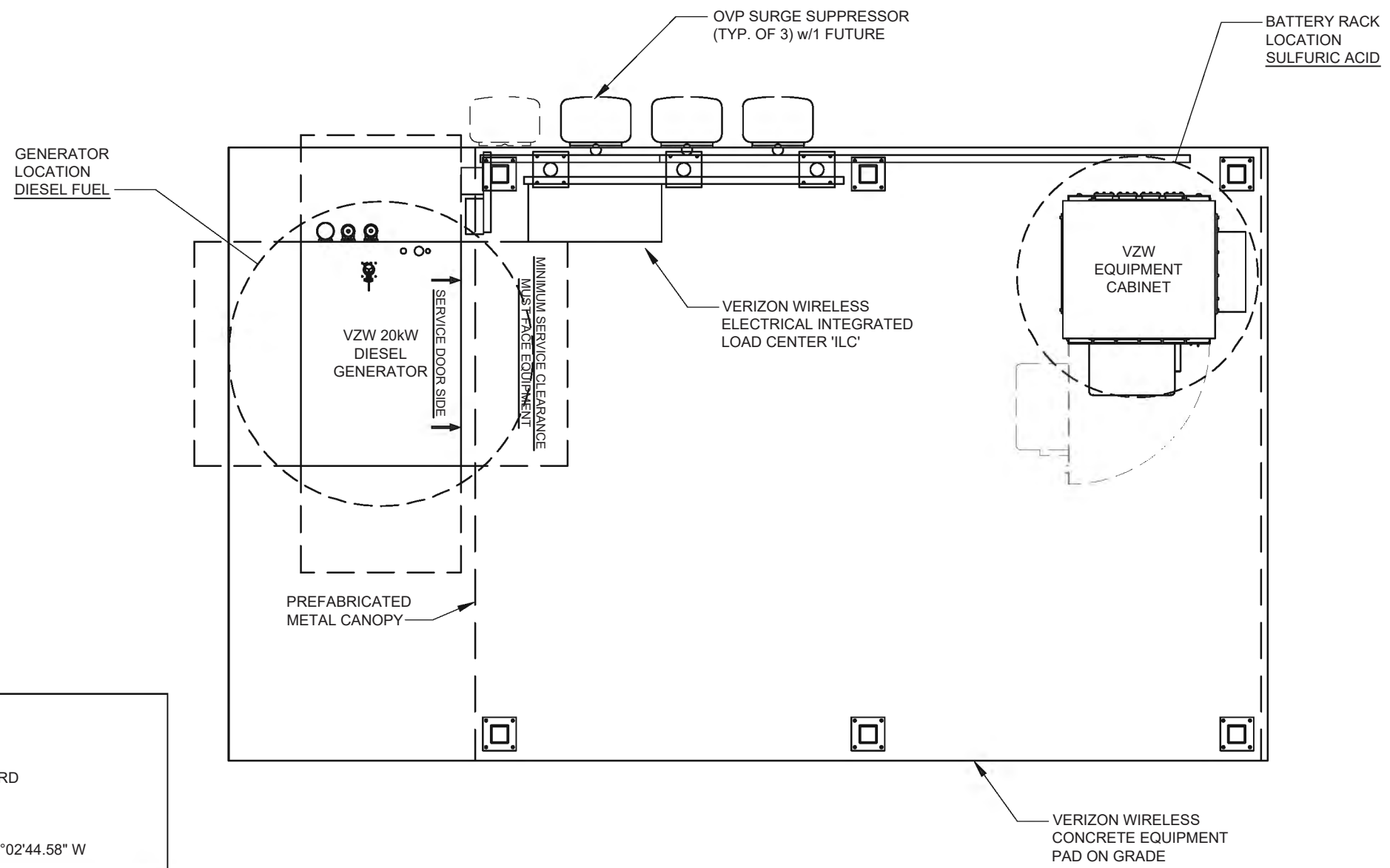

VERIZON WIRELESS
 SITE NAME: EV BARLOW - B
 SITE ADDRESS: XXXX STEVE DENTON RD
 BARLOW, KY 42024
 SITE EMIS#: 616190973
 SITE COORDINATES: 37°06'42.15" N, 89°02'44.58" W

NOTE:
 LOCATION OF VERIZON WIRELESS EQUIPMENT PAD
 IN RELATION TO PUBLIC RIGHTS OF WAY ARE FOR
 REFERENCE ONLY. DISTANCE TO RIGHTS OF WAY
 VARIES.

VERIZON WIRELESS TIER II EQUIPMENT PLAN

SCALE: N.T.S.



Drawing Name: O:\2017\2017770385\EV Barlow\AEC\DWG\Barlow CD.dwg
 February 8, 2019 2:28 PM - skrschner

Legs	4.25 S.R.	4.0 S.R.	3.75 S.R.	3.25 S.R.	3.0 S.R.	2.75 S.R.	2.5 S.R.	2.0 S.R.	1.75 S.R.
Diagonals	L 3 X 3 X 1/4	L 3 1/2 X 3 1/2 X 1/4	L 2 1/2 X 2 1/2 X 3/16	L 2 X 2 X 3/16	L 2 X 2 X 3/16	L 2 X 2 X 1/8	L 2 X 2 X 1/8	L 2 X 2 X 1/8	L 2 X 2 X 1/8
Horizontals	A	C	NONE	NONE	NONE	NONE	NONE	NONE	NONE
Internals	C	D	NONE	NONE	NONE	NONE	NONE	NONE	NONE
Sub-Diagonals	D	(1) 3/4"	(1) 3/4"	(1) 3/4"	(1) 3/4"	(1) 3/4"	(1) 3/4"	(1) 3/4"	(1) 3/4"
Sub-Horizontals	D	(2) 3/4"	(2) 3/4"	(2) 3/4"	(2) 3/4"	(2) 3/4"	(2) 3/4"	(2) 3/4"	(2) 3/4"
Brace Bolts	22.5	20.75	17.25	15.5	13.75	12	10.25	8.5	6.75
Top Face Width	22.5	20.75	17.25	15.5	13.75	12	10.25	8.5	6.75
Panel Count/Height	2 @ 10'	18 @ 6.6667'	16 @ 6.6667'	14 @ 6.6667'	12 @ 6.6667'	10 @ 6.6667'	8 @ 6.6667'	6 @ 6.6667'	4 @ 6.6667'
Section Weight	5038	5808	5625	4383	4269	3663	3561	2790	2058
								1850	1150
									1000

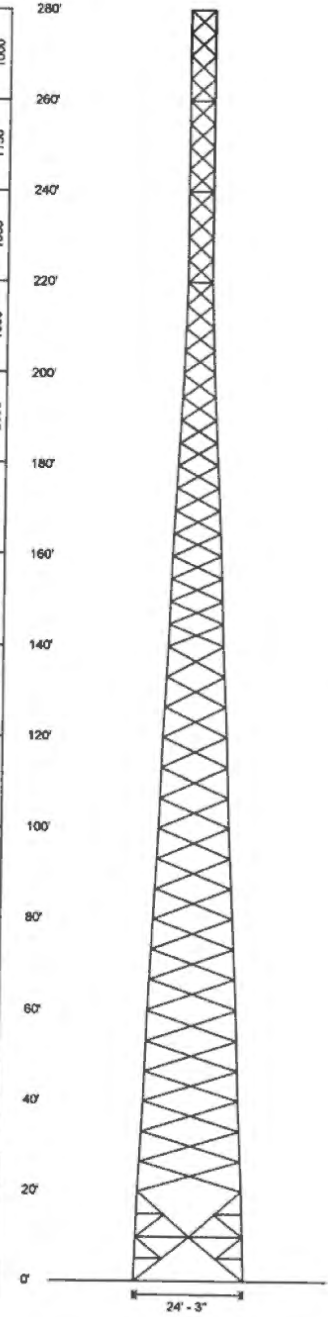

Design Criteria - ANSI/TIA-222-H

Wind Speed (No Ice)	107 mph
Wind Speed (Ice)	30 mph
Design Ice Thickness	1.50 in
Risk Category	II
Exposure Category	C
Topographic Factor Procedure	Method 1 (Simplified)
Topographic Category	1
Ground Elevation	361 ft

Base Reactions

Total Foundation		Individual Footing	
Shear (kips)	61.54	Shear (kips)	37.71
Axial (kips)	189.36	Compression (kips)	443
Moment (ft-kips)	8768	Uplift (kips)	382
Torsion (ft-kips)	28.97		

Material List

Display	Value
A	L 3 X 3 X 1/4
B	L 2 X 2 X 1/8
C	L 3 X 3 X 3/16
D	L 2 1/2 X 2 1/2 X 3/16

- ### Notes
- All legs are A572 Grade 50.
 - All braces are A572 Grade 50.
 - All brace bolts are A325-X.
 - The tower model is S3R Series SD.
 - Transmission lines are to be attached to standard 12 hole waveguide ladders with stackable hangers.
 - Azimuths are relative (not based on true north).
 - Foundation loads shown are maximums.
 - All unequal angles are oriented with the short leg vertical.
 - Weights shown are estimates. Final weights may vary.
 - This tower design and, if applicable, the foundation design(s) shown on the following page(s) also meet or exceed the requirements of the 2012 International Building Code.
 - Tower Rating: 97.02%

Designed Appurtenance Loading

Elev	Description	Tx-Line
275	3V-Boom - 12ft Face - 3ft Standoff	
275	(1) RCMDC-6627-PF-48	
275	(3) 4449 B13 + B5	
275	(3) 8843 B2 + B6A	
275	(3) CBC78T-DS-43	
275	(6) JAHH-85C-R3B	(2) 1 1/4"
260	Leg Dish Mount	
260	(1) 8' Solid Dish W/ Radome	(1) 1 5/8"
245	3V-Boom - 10ft Face - 3ft Standoff	

Elev	Description	Tx-Line
245	(6) JAHH-85C-R3B	(12) 1 5/8"
230	3V-Boom - 10ft Face - 3ft Standoff	
230	(6) JAHH-85C-R3B	(12) 1 5/8"
215	3V-Boom - 10ft Face - 3ft Standoff	
215	(6) JAHH-85C-R3B	(12) 1 5/8"
200	3V-Boom - 10ft Face - 3ft Standoff	
200	(6) JAHH-85C-R3B	(12) 1 5/8"
185	Leg Dish Mount	
185	(1) 8' Solid Dish W/ Radome	(1) 1 5/8"

Sabre Communications Corporation
 7101 Southbridge Drive
 P.O. Box 654
 Sioux City, IA 51102-0654
 Phone: (712) 258-8800
 Fax: (712) 279-0814

Job: 19-5171-TJH
 Customer: VERIZON WIRELESS
 Site Name: Barlow, KY 232179
 Description: 280' S3R
 Date: 12/13/2018 By: NM

Sabre Communications Corporation
 7101 Southbridge Drive
 P.O. Box 654
 Sioux City, IA 51102-0654
 Phone: (712) 258-8800
 Fax: (712) 279-0814

Job: 19-5171-TJH
 Customer: VERIZON WIRELESS
 Site Name: Barlow, KY 232179
 Description: 280' S3R
 Date: 12/13/2018 By: NM

GPD GROUP, INC.
 520 South Main Street, Suite 2531
 Akron, OH 44311
 330.572.2100 Fax: 330.572.2102

KENTUCKY RSA No. 1 PARTNERSHIP
 d/b/a VERIZON WIRELESS

 280 E. 8TH STREET
 INDIANAPOLIS, INDIANA 46240

REV	DATE	DESCRIPTION
A	10/31/18	ISSUED FOR 90% REVIEW
B	01/22/19	ADDED DISTANCE TO HOUSE
C	01/24/19	ADDED BUILDING CALL OUTS AND REVISED SHEET TITLE
0	02/08/19	FINAL CONSTRUCTION DRAWINGS

REFERENCE ONLY

EV BARLOW
 2557 STEVE DENTON ROAD
 BARLOW, KY 42024

TOWER DETAILS
 (REFERENCE ONLY)

ISSUED FOR:	
REVIEW	--
PERMIT	--
CONSTRUCTION	--
RECORD	--
PROJECT MANAGER	DESIGNER
TTP	DTC

JOB NO.
2017770.39

TW-1

TOWER ELEVATION

1

TW-1

SCALE: N.T.S.

DESIGN APPURTENANCE LOADING

2

TW-1

SCALE: N.T.S.

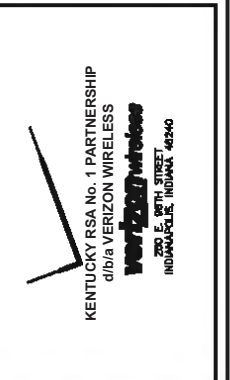

No.: 19-5171-TJH
 Date: 12/13/2018
 By: NM

Customer: VERIZON WIRELESS
Site: Barlow, KY 232179
 280 ft. Model S3R Series SD Self Supporting Tower

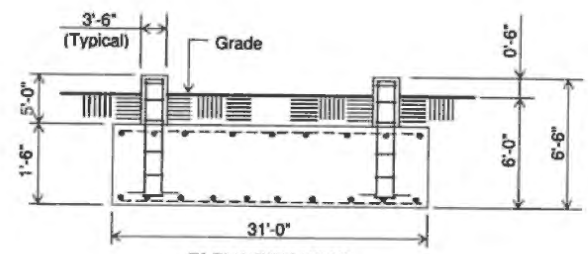
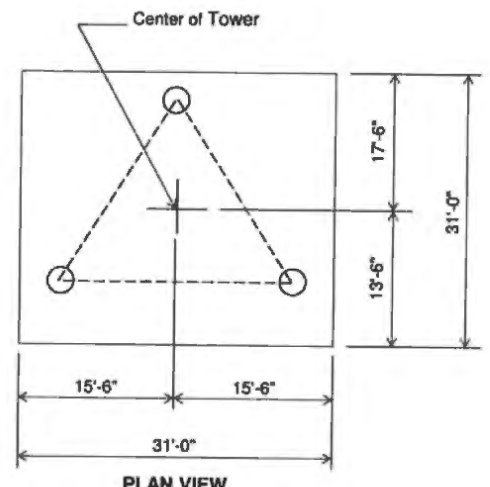

ELEVATION VIEW
 (58.7 cu. yds.)
 (1 REQD.; NOT TO SCALE)

CAUTION: Center of tower is not in center of slab.

- Notes:**
- 1) Concrete shall have a minimum 28-day compressive strength of 4,500 psi, in accordance with ACI 318-14.
 - 2) Rebar to conform to ASTM specification A615 Grade 60.
 - 3) All rebar to have a minimum of 3" concrete cover.
 - 4) All exposed concrete corners to be chamfered 3/4".
 - 5) The foundation design is based on the geotechnical report by Alt & Witzig Engineering, Inc., Project No. 18IN0510 dated: August 30th, 2018.
 - 6) See the geotechnical report for compaction requirements, if specified.
 - 7) 4.5' of soil cover is required over the entire area of the foundation slab.
 - 8) The bottom anchor bolt template shall be positioned as closely as possible to the bottom of the anchor bolts.
 - 9) Tie overlaps shall be staggered with a nominal 180° separation.

Rebar Schedule per Mat and per Pier	
Pier	(18) #7 vertical rebar w/ hooks at bottom w/ #4 rebar ties, two (2) within top 5" of pier then 4" C/C
Mat	(59) #9 horizontal rebar evenly spaced each way top and bottom. (236 total)
Anchor Bolts per Leg	
(6)	1.25" dia. x 63" F1554-105 on a 10" B.C. w/ 7.5" max. projection above concrete.

Information contained herein is the sole property of Sabre Towers & Poles, constitutes a trade secret as defined by Iowa Code Ch. 550 and shall not be reproduced, copied or used in whole or part for any purpose whatsoever without the prior written consent of Sabre Towers & Poles.
 7101 Southbridge Dr - P.O. Box 658 - Slouss City, IA 51102-0658 - Phone 712.258.8690 - Fax 712.258.8250

REV	DATE	DESCRIPTION
A	10/31/18	ISSUED FOR 90% REVIEW
B	01/22/19	ADDED DISTANCE TO HOUSE
C	01/24/19	ADDED BUILDING CALL OUTS AND REVISED SHEET TITLE
0	02/08/19	FINAL CONSTRUCTION DRAWINGS

REFERENCE ONLY

EV BARLOW
 2557 STEVE DENTON ROAD
 BARLOW, KY 42024

TOWER DETAILS
 (REFERENCE ONLY)

ISSUED FOR:	
REVIEW	--
PERMIT	--
CONSTRUCTION	--
RECORD	--
PROJECT MANAGER	DESIGNER
TTP	DTC

JOB NO.
2017770.39

TW-2

BENCHMARK SERVICES, INC.
Consulting Engineers & Land Surveyors
318 NORTH MAIN STREET
HUNTINGBURG, INDIANA 47542
(812) 683-3049

January 15, 2019

TO: Whom it may concern,

**RE: Verizon Site Name: EV Barlow
Flood Data Ballard County, KY**

Parcel Owner: Myatt Family Trust
Charles Myatt & Deena Myatt, Trustees
2557 Steve Denton Road
Barlow, KY 42024

Proposed Center of Tower: Latitude 37° 06' 42.145" and the Longitude of 89° 02' 44.583" and a ground elevation of 363.85' AMSL.

A small portion on the Northwest Parent Parcel Property is located in Zone "AE", The proposed Lease Area, the proposed Access & Utility Easements and the proposed Center of Tower are not located in a 100-year flood plain (Zone X) per Flood Hazard Boundary Map, Community Panel No 21007C0085C, dated of July, 7, 2014.

Please see the attached Map 21007C0085C.

RALPH M. WALLEM
BENCHMARK SERVICES, INC.
Consulting Engineers & Land Surveyors
DATE: 1.15.2019
PROFESSIONAL LAND SURVEYOR NO. 2195



National Flood Hazard Layer FIRMette



37°6'56.47"N



Legend

SEE FIS REPORT FOR DETAILED LEGEND AND INDEX MAP FOR FIRM PANEL LAYOUT

SPECIAL FLOOD HAZARD AREAS		Without Base Flood Elevation (BFE) Zone A, V, A99
		With BFE or Depth Zone AE, AD, AH, VE, AR
		Regulatory Floodway
OTHER AREAS OF FLOOD HAZARD		0.2% Annual Chance Flood Hazard, Areas of 1% annual chance flood with average depth less than one foot or with drainage areas of less than one square mile Zone X
		Future Conditions 1% Annual Chance Flood Hazard Zone X
		Area with Reduced Flood Risk due to Levee. See Notes, Zone X
		Area with Flood Risk due to Levee Zone D
OTHER AREAS		NO SCREEN Area of Minimal Flood Hazard Zone X
		Effective LOMRs
GENERAL STRUCTURES		Area of Undetermined Flood Hazard Zone D
		Channel, Culvert, or Storm Sewer
		Levee, Dike, or Floodwall
OTHER FEATURES		Cross Sections with 1% Annual Chance Water Surface Elevation
		Coastal Transect
		Coastal Transect Elevation
		Base Flood Elevation Line (BFE)
		Limit of Study
MAP PANELS		Jurisdiction Boundary
		Coastal Transect Baseline
		Profile Baseline
		Hydrographic Feature
		Digital Data Available
		No Digital Data Available
		Unmapped
		The pin displayed on the map is an approximate point selected by the user and does not represent an authoritative property location.

This map complies with FEMA's standards for the use of digital flood maps if it is not void as described below. The basemap shown complies with FEMA's basemap accuracy standards

The flood hazard information is derived directly from the authoritative NFHL web services provided by FEMA. This map was exported on 1/15/2019 at 12:38:07 PM and does not reflect changes or amendments subsequent to this date and time. The NFHL and effective information may change or become superseded by new data over time.

This map image is void if the one or more of the following map elements do not appear: basemap imagery, flood zone labels, legend, scale bar, map creation date, community identifiers, FIRM panel number, and FIRM effective date. Map images for unmapped and unmodernized areas cannot be used for regulatory purposes.

USGS The National Map: Orthoimagery. Data refreshed October, 2017.

0 250 500 1,000 1,500 2,000 Feet 1:6,000

89°25'33.28\"/>



Structural Design Report
280' S3R Series SD Self-Supporting Tower
Site: Barlow, KY
Site Number: 232179

Prepared for: VERIZON WIRELESS
by: Sabre Towers & Poles™
Job Number: 19-5171-TJH

December 13, 2018

Tower Profile.....	1-2
Foundation Design Summary (Option 1).....	3
Foundation Design Summary (Option 2).....	4
Maximum Leg Loads.....	5
Maximum Diagonal Loads.....	6
Maximum Foundation Loads.....	7
Calculations.....	8-26

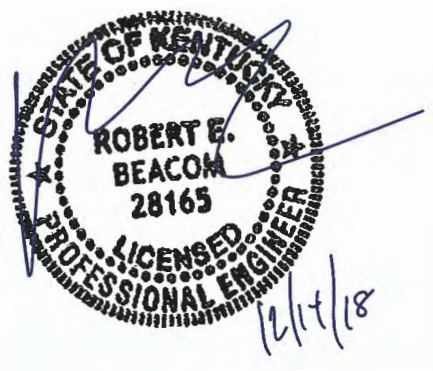

Legs	4.25 S.R.	4.0 S.R.	3.75 S.R.	3.25 S.R.	3.0 S.R.	2.75 S.R.	2.5 S.R.	2.0 S.R.	1.75 S.R.
Diagonals	L 3 X 3 X 1/4	L 3 X 3 X 3/16	L 2 1/2 X 2 1/2 X 3/16	L 2 X 2 X 3/16	L 2 X 2 X 1/8				
Horizontals	A	NONE							
Internals	C	NONE							
Sub-Diagonals	D	NONE							
Sub-Horizontals	D	NONE							
Brace Bolts	(2) 3/4"	(1) 3/4"							
Top Face Width	22.5'	20.75'	19'	17.25'	15.5'	13.75'	12'	10.25'	8.5'
Panel Count/Height	2 @ 10'	18 @ 6.6667'		28 @ 5'					
Section Weight	6038	5808	5625	4383	4269	3653	3561	2790	2098
						1850	1555	1150	1000

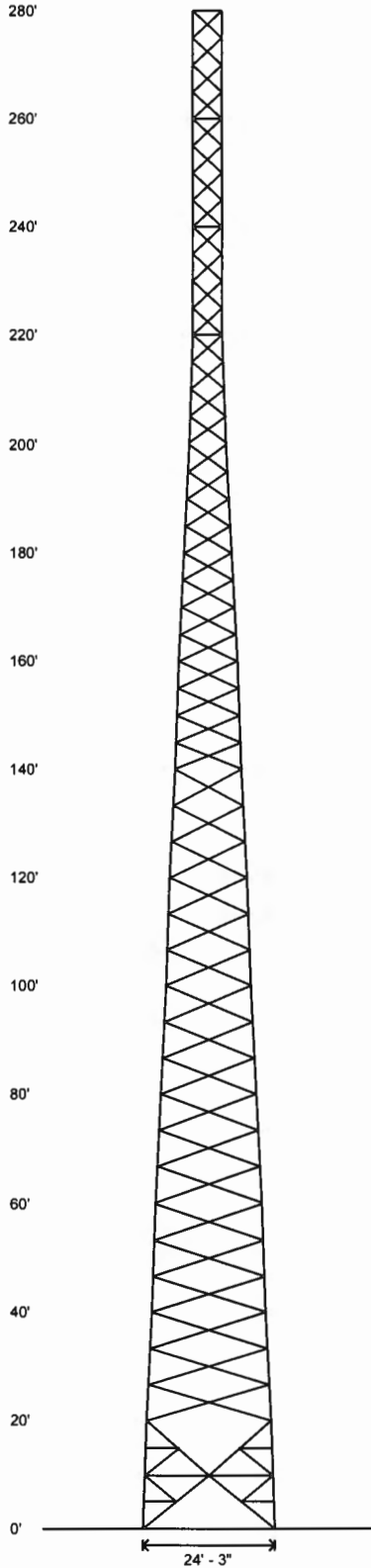

Design Criteria - ANSI/TIA-222-H

Wind Speed (No Ice)	107 mph
Wind Speed (Ice)	30 mph
Design Ice Thickness	1.50 in
Risk Category	II
Exposure Category	C
Topographic Factor Procedure	Method 1 (Simplified)
Topographic Category	1
Ground Elevation	361 ft

Base Reactions

Total Foundation		Individual Footing	
Shear (kips)	61.54	Shear (kips)	37.71
Axial (kips)	189.36	Compression (kips)	443
Moment (ft-kips)	8768	Uplift (kips)	382
Torsion (ft-kips)	28.97		

Material List

Display	Value
A	L 3 X 3 X 1/4
B	L 2 X 2 X 1/8
C	L 3 X 3 X 3/16
D	L 2 1/2 X 2 1/2 X 3/16

Notes

- 1) All legs are A572 Grade 50.
- 2) All braces are A572 Grade 50.
- 3) All brace bolts are A325-X.
- 4) The tower model is S3R Series SD.
- 5) Transmission lines are to be attached to standard 12 hole waveguide ladders with stackable hangers.
- 6) Azimuths are relative (not based on true north).
- 7) Foundation loads shown are maximums.
- 8) All unequal angles are oriented with the short leg vertical.
- 9) Weights shown are estimates. Final weights may vary.
- 10) This tower design and, if applicable, the foundation design(s) shown on the following page(s) also meet or exceed the requirements of the 2012 International Building Code.
- 11) Tower Rating: 97.02%

	Sabre Communications Corporation 7101 Southbridge Drive P.O. Box 658 Sioux City, IA 51102-0658 Phone: (712) 258-6690 Fax: (712) 279-0614	Job: 19-5171-TJH Customer: VERIZON WIRELESS Site Name: Barlow, KY 232179 Description: 280' S3R Date: 12/13/2018 By: NM
	<small>Information contained herein is the sole property of Sabre Communications Corporation, constitutes a trade secret as defined by Iowa Code Ch. 530 and shall not be reproduced, copied or used in whole or part for any purpose whatsoever without the prior written consent of Sabre Communications Corporation.</small>	

Designed Appurtenance Loading

Elev	Description	Tx-Line
275	3V-Boom - 12ft Face - 3ft Standoff	
275	(1) RCMDC-6627-PF-48	
275	(3) 4449 B13 + B5	
275	(3) 8843 B2 + B66A	
275	(3) CBC78T-DS-43	
275	(6) JAHH-65C-R3B	(2) 1 1/4"
260	Leg Dish Mount	
260	(1) 8' Solid Dish W/ Radome	(1) 1 5/8"
245	3V-Boom - 10ft Face - 3ft Standoff	

Elev	Description	Tx-Line
245	(6) JAHH-65C-R3B	(12) 1 5/8"
230	3V-Boom - 10ft Face - 3ft Standoff	
230	(6) JAHH-65C-R3B	(12) 1 5/8"
215	3V-Boom - 10ft Face - 3ft Standoff	
215	(6) JAHH-65C-R3B	(12) 1 5/8"
200	3V-Boom - 10ft Face - 3ft Standoff	
200	(6) JAHH-65C-R3B	(12) 1 5/8"
185	Leg Dish Mount	
185	(1) 8' Solid Dish W/ Radome	(1) 1 5/8"

	Sabre Communications Corporation 7101 Southbridge Drive P. O. Box 858 Sioux City, IA 51102-0658 Phone: (712) 258-8690 Fax: (712) 279-0614	Job: 19-5171-TJH Customer: VERIZON WIRELESS Site Name: Barlow, KY 232179 Description: 280' S3R Date: 12/13/2018 By: NM
	<small>Information contained herein is the sole property of Sabre Communications Corporation, constitutes a trade secret as defined by Iowa Code Ch. 550 and shall not be reproduced, copied or used in whole or part for any purpose whatsoever without the prior written consent of Sabre Communications Corporation.</small>	

Customer: VERIZON WIRELESS

Site: Barlow, KY 232179

280 ft. Model S3R Series SD Self Supporting Tower

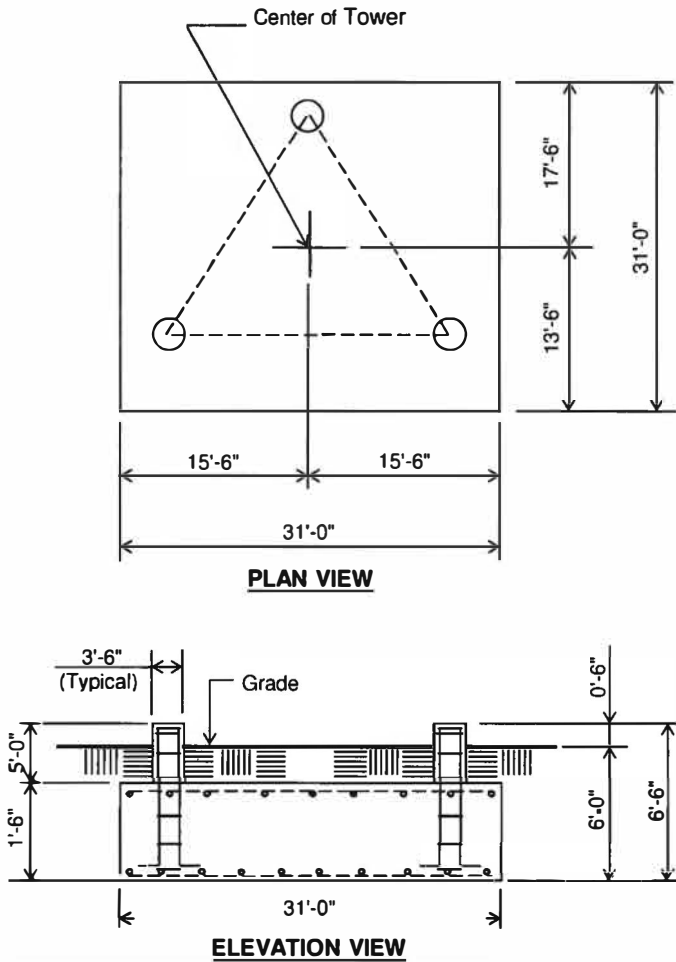

PLAN VIEW

ELEVATION VIEW

(58.7 cu. yds.)

(1 REQD.; NOT TO SCALE)

CAUTION: Center of tower is not in center of slab.

Notes:

- 1) Concrete shall have a minimum 28-day compressive strength of 4,500 psi, in accordance with ACI 318-14.
- 2) Rebar to conform to ASTM specification A615 Grade 60.
- 3) All rebar to have a minimum of 3" concrete cover.
- 4) All exposed concrete corners to be chamfered 3/4".
- 5) The foundation design is based on the geotechnical report by Alt & Witzig Engineering, Inc., Project No. 18IN0510 dated: August 30th, 2018.
- 6) See the geotechnical report for compaction requirements, if specified.
- 7) 4.5' of soil cover is required over the entire area of the foundation slab.
- 8) The bottom anchor bolt template shall be positioned as closely as possible to the bottom of the anchor bolts.
- 9) Tie overlaps shall be staggered with a nominal 180° separation.

Rebar Schedule per Mat and per Pier	
Pier	(18) #7 vertical rebar w/ hooks at bottom w/ #4 rebar ties, two (2) within top 5" of pier then 4" C/C
Mat	(59) #9 horizontal rebar evenly spaced each way top and bottom. (236 total)
Anchor Bolts per Leg	
(6) 1.25" dia. x 63" F1554-105 on a 10" B.C. w/ 7.5" max. projection above concrete.	

Information contained herein is the sole property of Sabre Towers & Poles, constitutes a trade secret as defined by Iowa Code Ch. 550 and shall not be reproduced, copied or used in whole or part for any purpose whatsoever without the prior written consent of Sabre Towers & Poles.

Customer: VERIZON WIRELESS

Site: Barlow, KY 232179

280 ft. Model S3R Series SD Self Supporting Tower

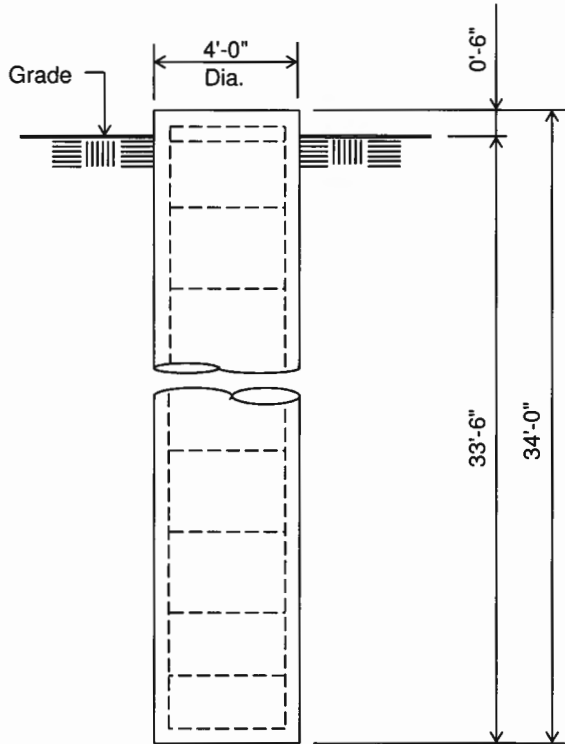

ELEVATION VIEW

(15.8 cu. yds.)

(3 REQUIRED; NOT TO SCALE)

Notes:

- 1) Concrete shall have a minimum 28-day compressive strength of 4,500 psi, in accordance with ACI 318-14.
- 2) Rebar to conform to ASTM specification A615 Grade 60.
- 3) All rebar to have a minimum of 3" concrete cover.
- 4) All exposed concrete corners to be chamfered 3/4".
- 5) The foundation design is based on the geotechnical report by Alt & Witzig Engineering, Inc., Project No. 18IN0510 dated: August 30th, 2018.
- 6) See the geotechnical report for drilled pier installation requirements, if specified.
- 7) The bottom anchor bolt template shall be positioned as closely as possible to the bottom of the anchor bolts.
- 8) Tie overlaps shall be staggered with a nominal 180° separation.

Rebar Schedule per Pier	
Pier	(12) #9 vertical rebar w/ #4 ties, two (2) within top 5" of pier then 12" C/C
Anchor Bolts per Leg	
	(6) 1.25" dia. x 63" F1554-105 on a 10" B.C. w/ 7.5" max. projection above concrete.

Information contained herein is the sole property of Sabre Towers & Poles, constitutes a trade secret as defined by Iowa Code Ch. 550 and shall not be reproduced, copied or used in whole or part for any purpose whatsoever without the prior written consent of Sabre Towers & Poles.

Maximum

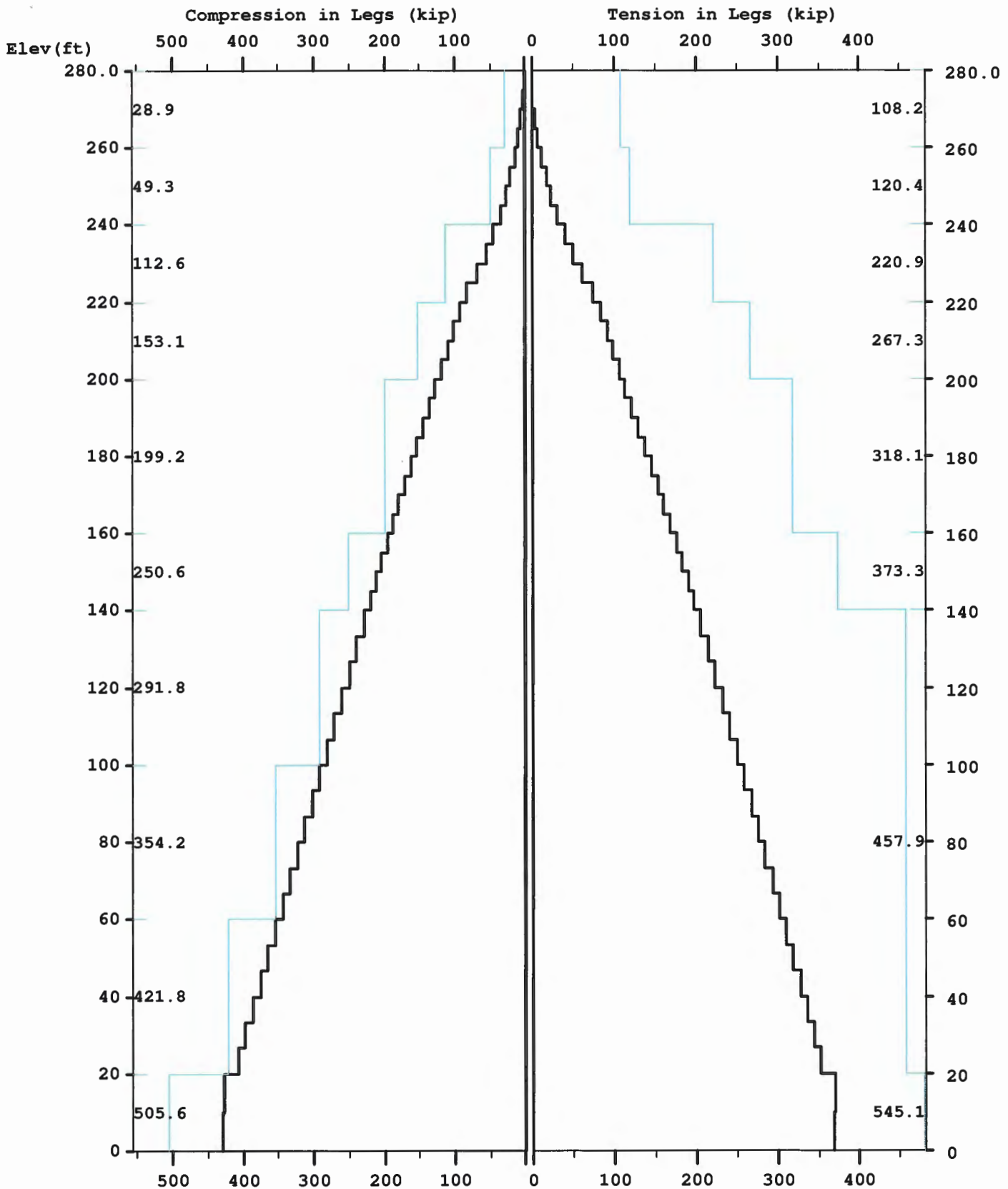

Maximum

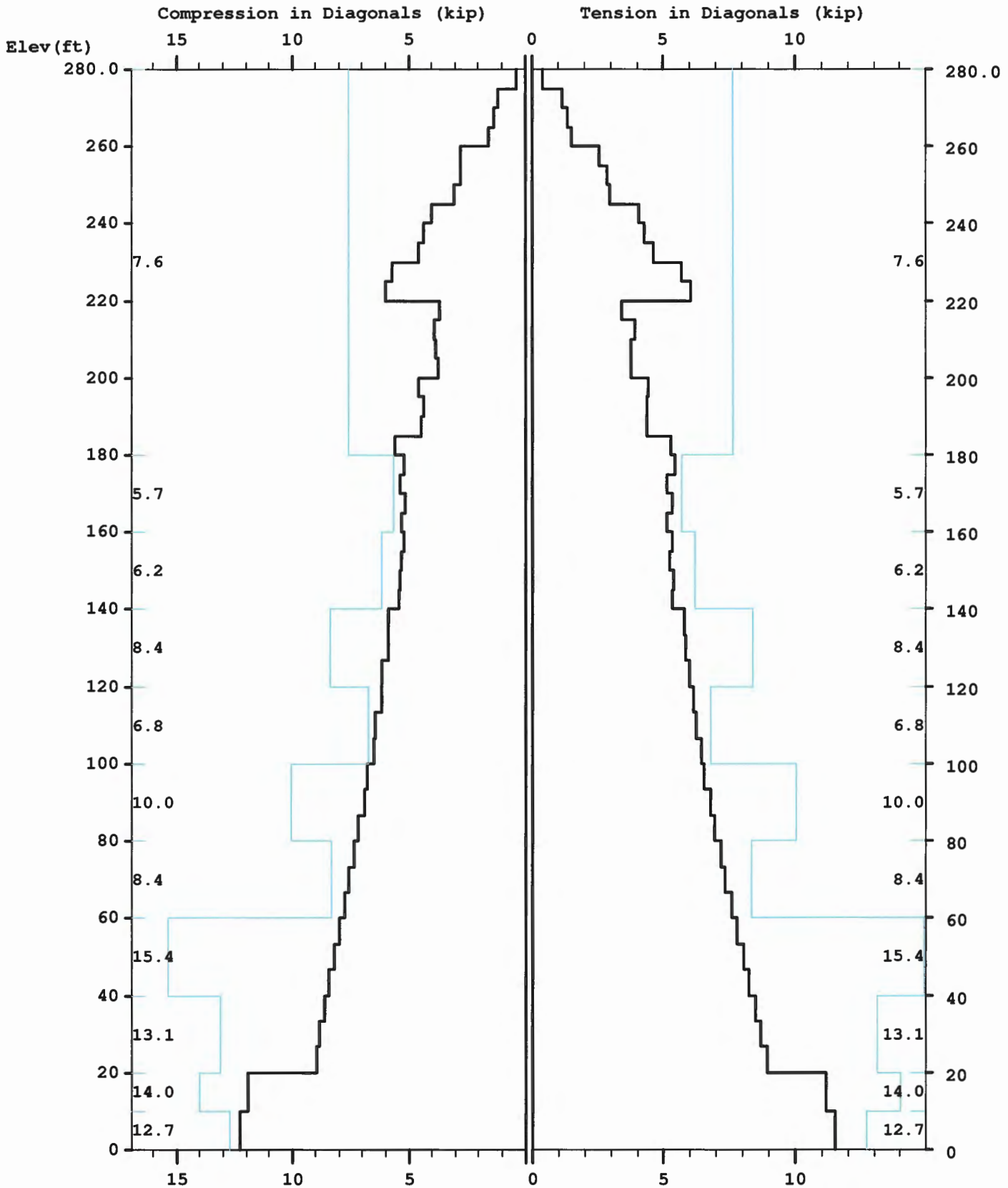

Maximum

TOTAL FOUNDATION LOADS (kip, ft-kip)

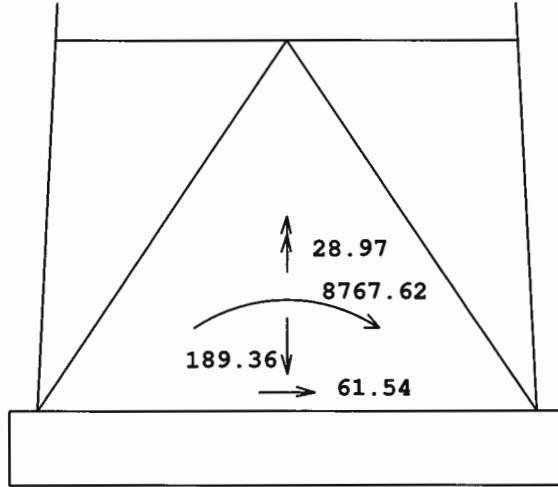

INDIVIDUAL FOOTING LOADS (kip)

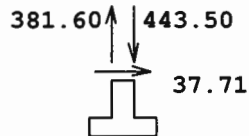
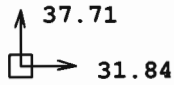

Latticed Tower Analysis (Unguyed)
 Processed under license at:

(c)2015 Guymast Inc. 416-736-7453

Sabre Towers and Poles

on: 13 dec 2018 at: 13:23:34

MAST GEOMETRY (ft)

PANEL TYPE	NO.OF LEGS	ELEV.AT BOTTOM	ELEV.AT TOP	F.W..AT BOTTOM	F.W..AT TOP	TYPICAL PANEL HEIGHT
X	3	275.00	280.00	5.00	5.00	5.00
X	3	260.00	275.00	5.00	5.00	5.00
X	3	255.00	260.00	5.00	5.00	5.00
X	3	240.00	255.00	5.00	5.00	5.00
X	3	235.00	240.00	5.00	5.00	5.00
X	3	220.00	235.00	5.00	5.00	5.00
X	3	215.00	220.00	5.44	5.00	5.00
X	3	200.00	215.00	6.75	5.44	5.00
X	3	180.00	200.00	8.50	6.75	5.00
X	3	160.00	180.00	10.25	8.50	5.00
X	3	140.00	160.00	12.00	10.25	5.00
X	3	120.00	140.00	13.75	12.00	6.67
X	3	100.00	120.00	15.50	13.75	6.67
X	3	80.00	100.00	17.25	15.50	6.67
X	3	60.00	80.00	19.00	17.25	6.67
X	3	40.00	60.00	20.75	19.00	6.67
X	3	20.00	40.00	22.50	20.75	6.67
V	3	10.00	20.00	23.37	22.50	10.00
A	3	0.00	10.00	24.25	23.37	10.00

MEMBER PROPERTIES

MEMBER TYPE	BOTTOM ELEV ft	TOP ELEV ft	X-SECTN AREA in.sq	RADIUS OF GYRAT in	ELASTIC MODULUS ksi	THERMAL EXPANSN /deg
LE	260.00	280.00	2.405	0.438	29000.	0.0000117
LE	240.00	260.00	3.142	0.438	29000.	0.0000117
LE	220.00	240.00	4.909	0.438	29000.	0.0000117
LE	200.00	220.00	5.940	0.438	29000.	0.0000117
LE	160.00	200.00	7.069	0.438	29000.	0.0000117
LE	140.00	160.00	8.296	0.438	29000.	0.0000117
LE	100.00	140.00	11.045	0.438	29000.	0.0000117
LE	60.00	100.00	12.566	0.438	29000.	0.0000117
LE	0.00	60.00	14.186	0.438	29000.	0.0000117
DI	160.00	280.00	0.484	0.626	29000.	0.0000117
DI	140.00	160.00	0.715	0.626	29000.	0.0000117
DI	100.00	140.00	0.902	0.626	29000.	0.0000117
DI	60.00	100.00	1.090	0.626	29000.	0.0000117
DI	20.00	60.00	1.688	0.626	29000.	0.0000117
DI	0.00	20.00	1.438	0.626	29000.	0.0000117
HO	275.00	280.00	0.484	0.626	29000.	0.0000117
HO	255.00	260.00	0.484	0.626	29000.	0.0000117
HO	235.00	240.00	0.484	0.626	29000.	0.0000117
HO	215.00	220.00	0.484	0.626	29000.	0.0000117
HO	0.00	10.00	1.438	0.626	29000.	0.0000117
BR	0.00	10.00	1.090	0.000	29000.	0.0000117

FACTORED MEMBER RESISTANCES

BOTTOM ELEV ft	TOP ELEV ft	LEGS		DIAGONALS		HORIZONTALS		INT BRACING	
		COMP kip	TENS kip	COMP kip	TENS kip	COMP kip	TENS kip	COMP kip	TENS kip
275.0	280.0	28.89	108.24	7.62	7.62	7.37	7.37	0.00	0.00
260.0	275.0	28.89	108.24	7.62	7.62	0.00	0.00	0.00	0.00
255.0	260.0	49.29	120.41	7.62	7.62	7.37	7.37	0.00	0.00
240.0	255.0	49.29	120.41	7.62	7.62	0.00	0.00	0.00	0.00
235.0	240.0	112.60	220.89	7.62	7.62	7.37	7.37	0.00	0.00
220.0	235.0	112.60	220.89	7.62	7.62	0.00	0.00	0.00	0.00

19-5171-TJH

215.0	220.0	153.15	267.28	7.62	7.62	7.37	7.37	0.00	0.00
200.0	215.0	153.15	267.28	7.62	7.62	0.00	0.00	0.00	0.00
180.0	200.0	199.21	318.09	7.62	7.62	0.00	0.00	0.00	0.00
160.0	180.0	199.21	318.09	5.68	5.68	0.00	0.00	0.00	0.00
140.0	160.0	250.56	373.31	6.19	6.19	0.00	0.00	0.00	0.00
120.0	140.0	291.83	457.90	8.39	8.39	0.00	0.00	0.00	0.00
100.0	120.0	291.83	457.90	6.77	6.77	0.00	0.00	0.00	0.00
80.0	100.0	354.16	457.90	10.03	10.03	0.00	0.00	0.00	0.00
60.0	80.0	354.16	457.90	8.35	8.35	0.00	0.00	0.00	0.00
40.0	60.0	421.75	457.90	15.39	15.39	0.00	0.00	0.00	0.00
20.0	40.0	421.75	457.90	13.14	13.14	0.00	0.00	0.00	0.00
10.0	20.0	505.61	545.12	14.02	14.02	0.00	0.00	0.00	0.00
0.0	10.0	505.61	545.12	12.71	12.71	13.05	13.05	9.39	9.39

=====

* Only 3 condition(s) shown in full
 * RRUS/TMAs were assumed to be behind antennas

* Some wind loads may have been derived from full-scale wind tunnel testing

=====

LOADING CONDITION A

107 mph wind with no ice. Wind Azimuth: 0°

PL - 0

MAST LOADING

LOAD TYPE	ELEV ft	APPLY.. RADIUS ft	LOAD.. AZI	LOAD AZIFORCES.....	MOMENTS.....	
					HORIZ kip	DOWN kip	VERTICAL ft-kip	TORSNAL ft-kip
C	275.0	0.00	0.0	0.0	1.98	2.79	0.00	0.00
C	245.0	0.00	0.0	0.0	1.74	2.10	0.00	0.00
C	230.0	0.00	0.0	0.0	1.71	2.10	0.00	0.00
C	215.0	0.00	0.0	0.0	1.69	2.10	0.00	0.00
C	200.0	0.00	0.0	0.0	1.66	2.10	0.00	0.00
D	280.0	0.00	180.0	0.0	0.06	0.05	0.00	0.00
D	275.0	0.00	180.0	0.0	0.06	0.05	0.00	0.00
D	275.0	0.00	42.0	0.0	0.07	0.06	0.01	0.03
D	260.0	0.00	42.0	0.0	0.07	0.06	0.01	0.03
D	260.0	0.00	42.0	0.0	0.08	0.07	0.02	0.03
D	245.0	0.00	42.0	0.0	0.07	0.06	0.02	0.03
D	245.0	0.00	42.0	0.0	0.11	0.08	0.05	0.08
D	240.0	0.00	42.0	0.0	0.11	0.08	0.05	0.08
D	240.0	0.00	42.0	0.0	0.12	0.11	0.05	0.08
D	230.0	0.00	42.0	0.0	0.11	0.10	0.05	0.08
D	230.0	0.00	56.0	0.0	0.13	0.12	0.06	0.10
D	220.0	0.00	56.0	0.0	0.14	0.12	0.06	0.10
D	220.0	0.00	57.2	0.0	0.14	0.14	0.06	0.10
D	215.0	0.00	57.2	0.0	0.14	0.14	0.06	0.10
D	215.0	0.00	83.4	0.0	0.15	0.15	0.06	0.11
D	200.0	0.00	87.2	0.0	0.15	0.15	0.06	0.10
D	200.0	0.00	90.5	0.0	0.17	0.19	0.06	0.06
D	185.0	0.00	93.1	0.0	0.18	0.19	0.05	0.06
D	185.0	0.00	84.7	0.0	0.18	0.19	0.06	0.06
D	160.0	0.00	86.2	0.0	0.18	0.19	0.06	0.06
D	160.0	0.00	80.8	0.0	0.18	0.22	0.08	0.07
D	140.0	0.00	82.6	0.0	0.19	0.23	0.07	0.06
D	140.0	0.00	78.2	0.0	0.19	0.26	0.09	0.07
D	120.0	0.00	79.5	0.0	0.19	0.27	0.08	0.07
D	120.0	0.00	76.2	0.0	0.19	0.27	0.10	0.07
D	100.0	0.00	77.2	0.0	0.19	0.27	0.09	0.07
D	100.0	0.00	74.7	0.0	0.20	0.30	0.11	0.07
D	80.0	0.00	75.5	0.0	0.21	0.31	0.10	0.07
D	80.0	0.00	73.4	0.0	0.20	0.31	0.12	0.07
D	60.0	0.00	74.1	0.0	0.20	0.31	0.12	0.07
D	60.0	0.00	72.4	0.0	0.21	0.38	0.14	0.07
D	40.0	0.00	72.9	0.0	0.21	0.39	0.13	0.07
D	40.0	0.00	71.5	0.0	0.20	0.39	0.15	0.07
D	20.0	0.00	72.0	0.0	0.20	0.40	0.14	0.07
D	20.0	0.00	70.8	0.0	0.15	0.34	0.16	0.06
D	10.0	0.00	70.8	0.0	0.15	0.34	0.16	0.06
D	10.0	0.00	71.1	0.0	0.18	0.41	0.15	0.06
D	0.0	0.00	71.1	0.0	0.18	0.41	0.15	0.06

ANTENNA LOADING
=====

.....ANTENNA.....	ATTACHMENT			ANTENNA FORCES.....			
TYPE	ELEV ft	AZI	RAD ft	AZI	AXIAL kip	SHEAR kip	GRAVITY kip	TORSION ft-kip
STD+R	260.0	0.0	4.4	0.0	1.40	0.00	0.40	0.00
STD+R	185.0	0.0	6.2	0.0	1.31	0.00	0.40	0.00

LOADING CONDITION k =====

107 mph wind with no ice. Wind Azimuth: 0

PL - 0

MAST LOADING
=====

LOAD TYPE	ELEV ft	APPLY..LOAD. RADIUS ft	..AT AZI	LOAD AZIFORCES.....	MOMENTS.....	
					HORIZ kip	DOWN kip	VERTICAL ft-kip	TORSNAL ft-kip
C	275.0	0.00	0.0	0.0	1.98	2.09	0.00	0.00
C	245.0	0.00	0.0	0.0	1.74	1.58	0.00	0.00
C	230.0	0.00	0.0	0.0	1.71	1.58	0.00	0.00
C	215.0	0.00	0.0	0.0	1.69	1.58	0.00	0.00
C	200.0	0.00	0.0	0.0	1.66	1.58	0.00	0.00
D	280.0	0.00	180.0	0.0	0.06	0.04	0.00	0.00
D	275.0	0.00	180.0	0.0	0.06	0.04	0.00	0.00
D	275.0	0.00	42.0	0.0	0.07	0.04	0.01	0.03
D	260.0	0.00	42.0	0.0	0.07	0.04	0.01	0.03
D	260.0	0.00	42.0	0.0	0.08	0.05	0.01	0.03
D	245.0	0.00	42.0	0.0	0.07	0.05	0.01	0.03
D	245.0	0.00	42.0	0.0	0.11	0.06	0.03	0.08
D	240.0	0.00	42.0	0.0	0.11	0.06	0.03	0.08
D	240.0	0.00	42.0	0.0	0.12	0.08	0.03	0.08
D	230.0	0.00	42.0	0.0	0.11	0.08	0.03	0.08
D	230.0	0.00	56.0	0.0	0.13	0.09	0.05	0.10
D	220.0	0.00	56.0	0.0	0.14	0.09	0.05	0.10
D	220.0	0.00	57.2	0.0	0.14	0.11	0.05	0.10
D	215.0	0.00	57.2	0.0	0.14	0.11	0.05	0.10
D	215.0	0.00	83.4	0.0	0.15	0.11	0.05	0.11
D	200.0	0.00	87.2	0.0	0.15	0.11	0.04	0.10
D	200.0	0.00	90.5	0.0	0.17	0.14	0.04	0.06
D	185.0	0.00	93.1	0.0	0.18	0.14	0.04	0.06
D	185.0	0.00	84.7	0.0	0.18	0.14	0.05	0.06
D	160.0	0.00	86.2	0.0	0.18	0.15	0.04	0.06
D	160.0	0.00	80.8	0.0	0.18	0.17	0.06	0.07
D	140.0	0.00	82.6	0.0	0.19	0.17	0.05	0.06
D	140.0	0.00	78.2	0.0	0.19	0.20	0.07	0.07
D	120.0	0.00	79.5	0.0	0.19	0.20	0.06	0.07
D	120.0	0.00	76.2	0.0	0.19	0.20	0.07	0.07
D	100.0	0.00	77.2	0.0	0.19	0.20	0.07	0.07
D	100.0	0.00	74.7	0.0	0.20	0.23	0.08	0.07
D	80.0	0.00	75.5	0.0	0.21	0.23	0.08	0.07
D	80.0	0.00	73.4	0.0	0.20	0.23	0.09	0.07
D	60.0	0.00	74.1	0.0	0.20	0.24	0.09	0.07
D	60.0	0.00	72.4	0.0	0.21	0.29	0.10	0.07
D	40.0	0.00	72.9	0.0	0.21	0.29	0.10	0.07
D	40.0	0.00	71.5	0.0	0.20	0.29	0.11	0.07
D	20.0	0.00	72.0	0.0	0.20	0.30	0.11	0.07
D	20.0	0.00	70.8	0.0	0.15	0.26	0.12	0.06
D	10.0	0.00	70.8	0.0	0.15	0.26	0.12	0.06
D	10.0	0.00	71.1	0.0	0.18	0.31	0.12	0.06
D	0.0	0.00	71.1	0.0	0.18	0.31	0.12	0.06

ANTENNA LOADING
=====

.....ANTENNA.....	ATTACHMENT			ANTENNA FORCES.....			
TYPE	ELEV ft	AZI	RAD ft	AZI	AXIAL kip	SHEAR kip	GRAVITY kip	TORSION ft-kip
STD+R	260.0	0.0	4.4	0.0	1.40	0.00	0.30	0.00
STD+R	185.0	0.0	6.2	0.0	1.31	0.00	0.30	0.00

LOADING CONDITION AU =====

30 mph wind with 1.5 ice. Wind Azimuth: 0°

PL - 0

MAST LOADING

=====

LOAD TYPE	ELEV ft	APPLY.. RADIUS ft	LOAD..AT AZI	LOAD AZIFORCES.....	MOMENTS.....	
					HORIZ kip	DOWN kip	VERTICAL ft-kip	TORSNAL ft-kip
C	275.0	0.00	0.0	0.0	0.29	5.78	0.00	0.00
C	245.0	0.00	0.0	0.0	0.25	4.66	0.00	0.00
C	230.0	0.00	0.0	0.0	0.25	4.64	0.00	0.00
C	215.0	0.00	0.0	0.0	0.24	4.63	0.00	0.00
C	200.0	0.00	0.0	0.0	0.24	4.61	0.00	0.00
D	280.0	0.00	180.0	0.0	0.01	0.19	0.00	0.00
D	275.0	0.00	180.0	0.0	0.01	0.19	0.00	0.00
D	275.0	0.00	42.0	0.0	0.01	0.19	0.07	0.01
D	260.0	0.00	42.0	0.0	0.01	0.19	0.07	0.01
D	260.0	0.00	42.0	0.0	0.01	0.24	0.08	0.01
D	255.0	0.00	42.0	0.0	0.01	0.24	0.08	0.01
D	255.0	0.00	42.0	0.0	0.01	0.21	0.08	0.01
D	245.0	0.00	42.0	0.0	0.01	0.21	0.08	0.01
D	245.0	0.00	42.0	0.0	0.01	0.26	0.20	0.01
D	240.0	0.00	42.0	0.0	0.01	0.26	0.20	0.01
D	240.0	0.00	42.0	0.0	0.01	0.32	0.20	0.01
D	235.0	0.00	42.0	0.0	0.01	0.32	0.20	0.01
D	235.0	0.00	42.0	0.0	0.01	0.29	0.20	0.01
D	230.0	0.00	42.0	0.0	0.01	0.29	0.20	0.01
D	230.0	0.00	62.1	0.0	0.02	0.35	0.21	0.01
D	220.0	0.00	62.1	0.0	0.02	0.35	0.21	0.01
D	220.0	0.00	63.2	0.0	0.02	0.40	0.21	0.01
D	215.0	0.00	63.2	0.0	0.02	0.40	0.21	0.01
D	215.0	0.00	91.3	0.0	0.02	0.42	0.23	0.01
D	205.0	0.00	93.2	0.0	0.02	0.43	0.22	0.01
D	205.0	0.00	95.1	0.0	0.02	0.43	0.21	0.01
D	200.0	0.00	95.1	0.0	0.02	0.43	0.21	0.01
D	200.0	0.00	85.6	0.0	0.02	0.52	0.17	0.00
D	185.0	0.00	87.6	0.0	0.02	0.53	0.15	0.00
D	185.0	0.00	79.6	0.0	0.02	0.53	0.19	0.00
D	160.0	0.00	80.5	0.0	0.02	0.56	0.17	0.00
D	160.0	0.00	76.3	0.0	0.02	0.59	0.22	0.00
D	140.0	0.00	77.7	0.0	0.02	0.60	0.20	0.00
D	140.0	0.00	74.3	0.0	0.02	0.63	0.26	0.00
D	120.0	0.00	75.2	0.0	0.02	0.64	0.23	0.00
D	120.0	0.00	72.7	0.0	0.02	0.64	0.29	0.00
D	100.0	0.00	73.4	0.0	0.02	0.66	0.27	0.00
D	100.0	0.00	71.4	0.0	0.02	0.71	0.32	0.00
D	80.0	0.00	72.0	0.0	0.02	0.72	0.30	0.00
D	80.0	0.00	70.4	0.0	0.02	0.72	0.36	0.00
D	60.0	0.00	70.9	0.0	0.02	0.74	0.33	0.00
D	60.0	0.00	69.6	0.0	0.02	0.82	0.39	0.00
D	40.0	0.00	70.0	0.0	0.02	0.84	0.37	0.00
D	40.0	0.00	69.0	0.0	0.02	0.83	0.42	0.00
D	20.0	0.00	69.3	0.0	0.02	0.84	0.40	0.00
D	20.0	0.00	68.4	0.0	0.02	0.74	0.50	0.00
D	10.0	0.00	68.4	0.0	0.02	0.74	0.50	0.00
D	10.0	0.00	68.4	0.0	0.02	0.99	0.62	0.00
D	0.0	0.00	68.4	0.0	0.02	0.99	0.62	0.00

ANTENNA LOADING

=====

.....ANTENNA..... TYPEATTACHMENT.....	ANTENNA FORCES.....					
	ELEV ft	AZI	RAD ft	AZI	AXIAL kip	SHEAR kip	GRAVITY kip	TORSION ft-kip
STD+R	260.0	0.0	4.4	0.0	0.12	0.00	1.57	0.00
STD+R	185.0	0.0	6.2	0.0	0.11	0.00	1.53	0.00

MAXIMUM ANTENNA AND REFLECTOR ROTATIONS:

=====

ELEV AZI TYPEBEAM DEFLECTIONS (deg).....

ft	deg	*	19-5171-TJH			TOTAL
			PITCH	YAW	ROLL	
260.0	0.0	STD+R	1.315 J	0.469 AL	-1.551 S	1.396 b
185.0	0.0	STD+R	0.827 J	0.218 AL	-0.978 S	0.855 J

MAXIMUM TENSION IN MAST MEMBERS (kip)

ELEV ft	LEGS	DIAG	HORIZ	BRACE
280.0	-----	-----	0.24 C	0.00 A
	0.16 AE	0.38 S		
275.0	-----	-----	0.03 g	0.00 A
	0.63 k	1.16 n		
270.0	-----	-----	0.02 A	0.00 A
	3.78 k	1.35 D		
265.0	-----	-----	0.03 J	0.00 A
	6.96 k	1.51 AF		
260.0	-----	-----	0.49 AF	0.00 A
	11.26 k	2.58 D		
255.0	-----	-----	0.08 M	0.00 A
	17.18 k	2.87 D		
250.0	-----	-----	0.02 m	0.00 A
	23.37 k	2.96 AF		
245.0	-----	-----	0.07 A	0.00 A
	30.25 k	4.07 D		
240.0	-----	-----	0.51 A	0.00 A
	39.77 k	4.27 n		
235.0	-----	-----	0.18 A	0.00 A
	49.79 k	4.63 D		
230.0	-----	-----	0.07 AC	0.00 A
	60.71 k	5.68 D		
225.0	-----	-----	0.20 A	0.00 A
	74.39 k	6.01 D		
220.0	-----	-----	0.55 AC	0.00 A
	84.01 k	3.43 k		
215.0	-----	-----	0.16 A	0.00 A
	91.47 k	3.91 X		
210.0	-----	-----	0.03 A	0.00 A
	98.93 k	3.77 AH		
205.0	-----	-----	0.16 A	0.00 A
	106.43 k	3.75 X		
200.0	-----	-----	0.01 AU	0.00 A
	113.33 k	4.40 k		
195.0	-----	-----	0.12 A	0.00 A
	121.72 k	4.35 S		
190.0	-----	-----	0.07 e	0.00 A
	129.31 k	4.37 AH		
185.0	-----	-----	0.09 A	0.00 A
	137.53 k	5.29 AH		
180.0	-----	-----	0.09 e	0.00 A
	144.93 k	5.44 F		
175.0	-----	-----	0.08 A	0.00 A
	153.56 k	5.15 AH		
170.0	-----	-----	0.06 e	0.00 A
	160.78 k	5.31 F		
165.0	-----	-----	0.07 A	0.00 A
	168.77 k	5.14 AH		
160.0	-----	-----	0.05 J	0.00 A
	175.84 k	5.31 F		
155.0	-----	-----	0.05 A	0.00 A
	183.39 k	5.21 AH		
150.0	-----	-----	0.05 M	0.00 A
	190.30 k	5.37 F		
145.0	-----	-----	0.05 A	0.00 A
	197.57 k	5.33 AH		
140.0	-----	-----	0.05 M	0.00 A
	205.43 k	5.80 F		
133.3	-----	-----	0.05 A	0.00 A
	214.77 k	5.83 AE		
126.7	-----	-----	0.04 M	0.00 A
	223.61 k	5.99 F		
120.0	-----	-----	0.05 A	0.00 A
	232.70 k	6.12 AE		
113.3	-----	-----	0.04 A	0.00 A
	241.44 k	6.23 F		
106.7	-----	-----	0.04 A	0.00 A
	250.34 k	6.43 AE		

19-5171-TJH					
100.0	-----			0.03 A	0.00 A
	258.96 k	6.54 j			
93.3	-----			0.04 A	0.00 A
	267.70 k	6.80 AE			
86.7	-----			0.03 A	0.00 A
	276.27 k	6.94 U			
80.0	-----			0.03 A	0.00 A
	284.97 k	7.20 AE			
73.3	-----			0.03 A	0.00 A
	293.52 k	7.36 U			
66.7	-----			0.03 A	0.00 A
	302.16 k	7.60 AE			
60.0	-----			0.03 A	0.00 A
	310.65 k	7.78 U			
53.3	-----			0.03 A	0.00 A
	319.16 k	8.03 AE			
46.7	-----			0.02 A	0.00 A
	327.59 k	8.22 U			
40.0	-----			0.02 A	0.00 A
	336.10 k	8.48 U			
33.3	-----			0.04 AE	0.00 A
	344.54 k	8.70 U			
26.7	-----			0.16 AC	0.00 A
	353.00 k	8.96 S			
20.0	-----			0.22 A	0.00 A
	369.91 k	11.17 AT			
10.0	-----			0.62 k	0.00 AF
	368.97 k	11.50 AT			
0.0	-----			0.00 A	0.00 A

MAXIMUM COMPRESSION IN MAST MEMBERS (kip)

ELEV ft	LEGS	DIAG	HORIZ	BRACE
280.0	-----		-0.24 U	0.00 A
	-0.25 C	-0.37 A		
275.0	-----		-0.02 y	0.00 A
	-2.64 BM	-1.17 V		
270.0	-----		-0.02 AC	0.00 A
	-6.01 S	-1.34 V		
265.0	-----		-0.01 AO	0.00 A
	-9.45 S	-1.55 D		
260.0	-----		-0.62 F	0.00 A
	-14.58 S	-2.75 G		
255.0	-----		-0.05 AC	0.00 A
	-20.66 S	-2.77 AF		
250.0	-----		-0.02 CA	0.00 A
	-26.88 S	-3.04 D		
245.0	-----		-0.05 AC	0.00 A
	-35.31 S	-4.03 V		
240.0	-----		-0.43 AC	0.00 A
	-45.07 S	-4.37 D		
235.0	-----		-0.16 AC	0.00 A
	-55.75 S	-4.57 n		
230.0	-----		-0.07 A	0.00 A
	-68.29 S	-5.73 D		
225.0	-----		-0.17 AC	0.00 A
	-82.62 S	-6.01 D		
220.0	-----		-0.64 A	0.00 A
	-92.65 S	-3.64 S		
215.0	-----		-0.14 AC	0.00 A
	-102.21 S	-3.87 AH		
210.0	-----		-0.02 AC	0.00 A
	-110.19 S	-3.87 S		
205.0	-----		-0.13 AC	0.00 A
	-118.42 S	-3.74 X		
200.0	-----		0.00 AC	0.00 A
	-127.18 S	-4.58 S		
195.0	-----		-0.10 AC	0.00 A
	-136.47 S	-4.35 AH		
190.0	-----		-0.04 w	0.00 A
	-144.73 S	-4.48 S		
185.0	-----		-0.09 k	0.00 A

19-5171-TJH

180.0	-154.26 S	-5.59 F	-0.05 t	0.00 A
175.0	-162.45 S	-5.21 AH	-0.07 AC	0.00 A
170.0	-171.51 S	-5.37 F	-0.04 AO	0.00 A
165.0	-179.61 S	-5.14 AH	-0.06 AC	0.00 A
160.0	-188.17 S	-5.31 F	-0.04 AO	0.00 A
155.0	-196.14 S	-5.19 AE	-0.04 AC	0.00 A
150.0	-204.45 S	-5.35 F	-0.04 AO	0.00 A
145.0	-212.31 S	-5.35 AE	-0.04 AC	0.00 A
140.0	-220.40 S	-5.44 F	-0.04 AO	0.00 A
133.3	-229.45 S	-5.89 U	-0.05 AC	0.00 A
126.7	-240.11 S	-5.91 F	-0.04 AC	0.00 A
120.0	-250.42 S	-6.16 U	-0.04 AC	0.00 A
113.3	-260.90 S	-6.20 U	-0.03 AC	0.00 A
106.7	-271.14 S	-6.46 U	-0.04 AC	0.00 A
100.0	-281.50 S	-6.54 U	-0.03 AC	0.00 A
93.3	-291.73 S	-6.80 U	-0.03 AC	0.00 A
86.7	-302.12 S	-6.93 U	-0.03 AC	0.00 A
80.0	-312.42 S	-7.20 U	-0.03 AC	0.00 A
73.3	-322.83 S	-7.35 U	-0.02 AC	0.00 A
66.7	-333.17 S	-7.59 U	-0.03 AC	0.00 A
60.0	-343.59 S	-7.75 U	-0.02 AC	0.00 A
53.3	-354.04 S	-8.01 U	-0.02 AC	0.00 A
46.7	-364.65 S	-8.20 U	-0.02 AC	0.00 A
40.0	-375.25 S	-8.46 U	-0.02 AC	0.00 A
33.3	-385.92 S	-8.64 U	-0.05 C	0.00 A
26.7	-396.60 S	-8.82 U	-0.19 A	0.00 A
20.0	-407.30 S	-8.96 U	-0.18 AC	0.00 A
10.0	-427.23 S	-11.91 S	-0.75 S	0.00 D
0.0	-428.48 S	-12.27 S	0.00 A	0.00 A

FORCE/RESISTANCE RATIO IN LEGS

MAST ELEV ft	-- LEG COMPRESSION --			---- LEG TENSION ----		
	MAX COMP	COMP RESIST	FORCE/ RESIST RATIO	MAX TENS	TENS RESIST	FORCE/ RESIST RATIO
280.00	0.25	28.89	0.01	0.16	108.24	0.00
275.00	2.64	28.89	0.09	0.63	108.24	0.01
270.00	6.01	28.89	0.21	3.78	108.24	0.03
265.00	9.45	28.89	0.33	6.96	108.24	0.06
260.00	14.58	49.29	0.30	11.26	120.41	0.09
255.00	20.66	49.29	0.42	17.18	120.41	0.14

19-5171-TJH

250.00	26.88	49.29	0.55	23.37	120.41	0.19
245.00	35.31	49.29	0.72	30.25	120.41	0.25
240.00	45.07	112.60	0.40	39.77	220.89	0.18
235.00	55.75	112.60	0.50	49.79	220.89	0.23
230.00	68.29	112.60	0.61	60.71	220.89	0.27
225.00	82.62	112.60	0.73	74.39	220.89	0.34
220.00	92.65	153.15	0.60	84.01	267.28	0.31
215.00	102.21	153.15	0.67	91.47	267.28	0.34
210.00	110.19	153.15	0.72	98.93	267.28	0.37
205.00	118.42	153.15	0.77	106.43	267.28	0.40
200.00	127.18	199.21	0.64	113.33	318.09	0.36
195.00	136.47	199.21	0.69	121.72	318.09	0.38
190.00	144.73	199.21	0.73	129.31	318.09	0.41
185.00	154.26	199.21	0.77	137.53	318.09	0.43
180.00	162.45	199.21	0.82	144.93	318.09	0.46
175.00	171.51	199.21	0.86	153.56	318.09	0.48
170.00	179.61	199.21	0.90	160.78	318.09	0.51
165.00	188.17	199.21	0.94	168.77	318.09	0.53
160.00	196.14	250.56	0.78	175.84	373.31	0.47
155.00	204.45	250.56	0.82	183.39	373.31	0.49
150.00	212.31	250.56	0.85	190.30	373.31	0.51
145.00	220.40	250.56	0.88	197.57	373.31	0.53
140.00	229.45	291.83	0.79	205.43	457.90	0.45
133.33	240.11	291.83	0.82	214.77	457.90	0.47
126.67	250.42	291.83	0.86	223.61	457.90	0.49
120.00	260.90	291.83	0.89	232.70	457.90	0.51
113.33	271.14	291.83	0.93	241.44	457.90	0.53
106.67	281.50	291.83	0.96	250.34	457.90	0.55
100.00	291.73	354.16	0.82	258.96	457.90	0.57
93.33	302.12	354.16	0.85	267.70	457.90	0.58
86.67	312.42	354.16	0.88	276.27	457.90	0.60
80.00	322.83	354.16	0.91	284.97	457.90	0.62
73.33	333.17	354.16	0.94	293.52	457.90	0.64
66.67	343.59	354.16	0.97	302.16	457.90	0.66
60.00	354.04	421.75	0.84	310.65	457.90	0.68
53.33	364.65	421.75	0.86	319.16	457.90	0.70
46.67	375.25	421.75	0.89	327.59	457.90	0.72
40.00	385.92	421.75	0.92	336.10	457.90	0.73
33.33	396.60	421.75	0.94	344.54	457.90	0.75
26.67	407.30	421.75	0.97	353.00	457.90	0.77

20.00	427.23	505.61	0.84	369.91	545.12	0.68
10.00	428.48	505.61	0.85	368.97	545.12	0.68
0.00						

FORCE/RESISTANCE RATIO IN DIAGONALS

MAST ELEV ft	- DIAG COMPRESSION -			--- DIAG TENSION ---		
	MAX COMP	COMP RESIST	FORCE/ RESIST RATIO	MAX TENS	TENS RESIST	FORCE/ RESIST RATIO
280.00	0.37	7.62	0.05	0.38	7.62	0.05
275.00	1.17	7.62	0.15	1.16	7.62	0.15
270.00	1.34	7.62	0.18	1.35	7.62	0.18
265.00	1.55	7.62	0.20	1.51	7.62	0.20
260.00	2.75	7.62	0.36	2.58	7.62	0.34
255.00	2.77	7.62	0.36	2.87	7.62	0.38
250.00	3.04	7.62	0.40	2.96	7.62	0.39
245.00	4.03	7.62	0.53	4.07	7.62	0.53
240.00	4.37	7.62	0.57	4.27	7.62	0.56
235.00	4.57	7.62	0.60	4.63	7.62	0.61
230.00	5.73	7.62	0.75	5.68	7.62	0.75
225.00	6.01	7.62	0.79	6.01	7.62	0.79
220.00	3.64	7.62	0.48	3.43	7.62	0.45
215.00	3.87	7.62	0.51	3.91	7.62	0.51
210.00	3.87	7.62	0.51	3.77	7.62	0.49
205.00	3.74	7.62	0.49	3.75	7.62	0.49
200.00	4.58	7.62	0.60	4.40	7.62	0.58
195.00	4.35	7.62	0.57	4.35	7.62	0.57
190.00	4.48	7.62	0.59	4.37	7.62	0.57
185.00	5.59	7.62	0.73	5.29	7.62	0.69
180.00	5.21	5.68	0.92	5.44	5.68	0.96
175.00	5.37	5.68	0.95	5.15	5.68	0.91
170.00	5.14	5.68	0.91	5.31	5.68	0.93
165.00	5.31	5.68	0.93	5.14	5.68	0.90
160.00	5.19	6.19	0.84	5.31	6.19	0.86
155.00	5.35	6.19	0.86	5.21	6.19	0.84
150.00	5.35	6.19	0.86	5.37	6.19	0.87
145.00	5.44	6.19	0.88	5.33	6.19	0.86
140.00	5.89	8.39	0.70	5.80	8.39	0.69
133.33	5.91	8.39	0.70	5.83	8.39	0.69
126.67	6.16	8.39	0.73	5.99	8.39	0.71
120.00	6.20	6.77	0.92	6.12	6.77	0.90
113.33	6.46	6.77	0.95	6.23	6.77	0.92

19-5171-TJH

106.67	6.54	6.77	0.97	6.43	6.77	0.95
100.00	6.80	10.03	0.68	6.54	10.03	0.65
93.33	6.93	10.03	0.69	6.80	10.03	0.68
86.67	7.20	10.03	0.72	6.94	10.03	0.69
80.00	7.35	8.35	0.88	7.20	8.35	0.86
73.33	7.59	8.35	0.91	7.36	8.35	0.88
66.67	7.75	8.35	0.93	7.60	8.35	0.91
60.00	8.01	15.39	0.52	7.78	15.39	0.51
53.33	8.20	15.39	0.53	8.03	15.39	0.52
46.67	8.46	15.39	0.55	8.22	15.39	0.53
40.00	8.64	13.14	0.66	8.48	13.14	0.65
33.33	8.82	13.14	0.67	8.70	13.14	0.66
26.67	8.96	13.14	0.68	8.96	13.14	0.68
20.00	11.91	14.02	0.85	11.17	14.02	0.80
10.00	12.27	12.71	0.97	11.50	12.71	0.91
0.00						

MAXIMUM INDIVIDUAL FOUNDATION LOADS: (kip)

NORTH	LOAD EAST	COMPONENTS DOWN	UPLIFT	TOTAL SHEAR
37.71 s	31.84 e	443.50 s	-381.60 k	37.71 s

MAXIMUM TOTAL LOADS ON FOUNDATION : (kip & kip-ft)

HORIZONTAL			DOWN	OVERTURNING		TORSION	
NORTH	EAST	TOTAL @ 0.0		NORTH	EAST	TOTAL @ 0.0	
61.5 s	52.9 b	61.5 s	189.4 BK	8767.6 s	7480.3 b	8767.6 s	29.0 AT

Latticed Tower Analysis (Unguyed)
 Processed under license at:

(c)2015 Guymast Inc. 416-736-7453

Sabre Towers and Poles

on: 13 dec 2018 at: 13:24:12

 ***** Service Load Condition *****

- * Only 1 condition(s) shown in full
- * RRUS/TMAS were assumed to be behind antennas
- * Some wind loads may have been derived from full-scale wind tunnel testing

LOADING CONDITION A

MAST LOADING
=====

LOAD TYPE	ELEV ft	APPLY. RADIUS ft	LOAD. AT AZI	LOAD AZIFORCES.....	MOMENTS.....	
					HORIZ kip	DOWN kip	VERTICAL ft-kip	TORSNAL ft-kip
C	275.0	0.00	0.0	0.0	0.62	2.33	0.00	0.00
C	245.0	0.00	0.0	0.0	0.55	1.75	0.00	0.00
C	230.0	0.00	0.0	0.0	0.54	1.75	0.00	0.00
C	215.0	0.00	0.0	0.0	0.53	1.75	0.00	0.00
C	200.0	0.00	0.0	0.0	0.52	1.75	0.00	0.00
D	280.0	0.00	180.0	0.0	0.02	0.05	0.00	0.00
D	260.0	0.00	42.0	0.0	0.02	0.05	0.02	0.01
D	260.0	0.00	42.0	0.0	0.03	0.06	0.01	0.01
D	245.0	0.00	42.0	0.0	0.02	0.05	0.01	0.01
D	245.0	0.00	42.0	0.0	0.03	0.07	0.04	0.03
D	240.0	0.00	42.0	0.0	0.03	0.07	0.04	0.03
D	240.0	0.00	42.0	0.0	0.04	0.09	0.04	0.03
D	230.0	0.00	42.0	0.0	0.04	0.09	0.04	0.03
D	230.0	0.00	56.0	0.0	0.04	0.10	0.05	0.03
D	220.0	0.00	56.0	0.0	0.04	0.10	0.05	0.03
D	220.0	0.00	57.2	0.0	0.05	0.12	0.05	0.03
D	215.0	0.00	57.2	0.0	0.05	0.12	0.05	0.03
D	215.0	0.00	83.4	0.0	0.05	0.13	0.05	0.03
D	200.0	0.00	87.2	0.0	0.05	0.13	0.05	0.03
D	200.0	0.00	90.5	0.0	0.05	0.16	0.05	0.02
D	185.0	0.00	93.1	0.0	0.06	0.16	0.04	0.02
D	185.0	0.00	84.7	0.0	0.06	0.16	0.05	0.02
D	160.0	0.00	86.2	0.0	0.06	0.16	0.05	0.02
D	160.0	0.00	80.8	0.0	0.06	0.19	0.06	0.02
D	140.0	0.00	82.6	0.0	0.06	0.19	0.06	0.02
D	140.0	0.00	78.2	0.0	0.06	0.22	0.07	0.02
D	120.0	0.00	79.5	0.0	0.06	0.22	0.07	0.02
D	120.0	0.00	76.2	0.0	0.06	0.22	0.08	0.02
D	100.0	0.00	77.2	0.0	0.06	0.23	0.08	0.02
D	100.0	0.00	74.7	0.0	0.06	0.25	0.09	0.02
D	80.0	0.00	75.5	0.0	0.06	0.26	0.09	0.02
D	80.0	0.00	73.4	0.0	0.06	0.26	0.10	0.02
D	60.0	0.00	74.1	0.0	0.06	0.26	0.10	0.02
D	60.0	0.00	72.4	0.0	0.07	0.32	0.11	0.02
D	40.0	0.00	72.9	0.0	0.07	0.32	0.11	0.02
D	40.0	0.00	71.5	0.0	0.06	0.33	0.12	0.02
D	20.0	0.00	72.0	0.0	0.06	0.33	0.12	0.02
D	20.0	0.00	70.8	0.0	0.05	0.28	0.13	0.02
D	10.0	0.00	70.8	0.0	0.05	0.28	0.13	0.02
D	10.0	0.00	71.1	0.0	0.06	0.34	0.13	0.02
D	0.0	0.00	71.1	0.0	0.06	0.34	0.13	0.02

ANTENNA LOADING
=====

.....ANTENNA..... TYPE	ATTACHMENT			ANTENNA FORCES.....			
	ELEV ft	AZI	RAD ft	AZI	AXIAL kip	SHEAR kip	GRAVITY kip	TORSION ft-kip
STD+R	260.0	0.0	4.4	0.0	0.44	0.00	0.34	0.00
STD+R	185.0	0.0	6.2	0.0	0.41	0.00	0.34	0.00

MAXIMUM MAST DISPLACEMENTS:
=====

ELEV ft	-----DEFLECTIONS (ft)-----			--TILTS (DEG)---		TWIST DEG
	NORTH	EAST	DOWN	NORTH	EAST	
280.0	1.192 S	-1.009 J	0.012 S	0.498 S	-0.422 J	-0.147 d
275.0	1.148 S	-0.972 J	0.012 S	0.498 S	-0.423 J	-0.147 d
270.0	1.104 S	-0.935 J	0.012 S	0.497 S	-0.422 J	-0.147 d
265.0	1.061 S	-0.898 J	0.011 S	0.495 S	-0.420 J	-0.147 d
260.0	1.017 S	-0.862 J	0.011 S	0.492 S	-0.416 J	-0.148 d
255.0	0.974 S	-0.825 J	0.011 S	0.487 S	-0.412 J	-0.141 d
250.0	0.932 S	-0.789 J	0.011 S	0.480 S	-0.406 J	-0.134 d
245.0	0.889 S	-0.753 J	0.010 S	0.472 S	-0.399 J	-0.128 d
240.0	0.848 S	-0.718 J	0.010 S	0.460 S	-0.389 J	-0.122 d

19-5171-TJH						
235.0	0.807 S	-0.684 J	0.010 S	0.451 S	-0.381 J	-0.116 d
230.0	0.768 S	-0.650 J	0.010 S	0.439 S	-0.371 J	-0.110 d
225.0	0.728 S	-0.617 J	0.009 S	0.425 S	-0.359 J	-0.104 d
220.0	0.691 S	-0.586 J	0.009 S	0.407 S	-0.344 J	-0.098 d
215.0	0.656 S	-0.556 J	0.009 S	0.392 S	-0.331 J	-0.092 d
210.0	0.621 S	-0.527 J	0.009 S	0.378 S	-0.319 J	-0.088 d
205.0	0.588 S	-0.499 J	0.009 S	0.362 S	-0.306 J	-0.083 d
200.0	0.557 S	-0.472 J	0.008 S	0.347 S	-0.293 J	-0.079 d
195.0	0.526 S	-0.446 J	0.008 S	0.335 S	-0.283 J	-0.075 d
190.0	0.497 S	-0.421 J	0.008 S	0.322 S	-0.272 J	-0.072 d
185.0	0.468 S	-0.397 J	0.008 S	0.309 S	-0.262 J	-0.069 d
180.0	0.441 S	-0.374 J	0.007 S	0.297 S	-0.251 J	-0.063 d
175.0	0.414 S	-0.352 J	0.007 S	0.284 S	-0.240 J	-0.057 d
170.0	0.389 S	-0.330 J	0.007 S	0.271 S	-0.229 J	-0.052 d
165.0	0.364 S	-0.310 J	0.007 S	0.258 S	-0.218 J	-0.047 d
160.0	0.341 S	-0.290 J	0.007 S	0.245 S	-0.207 J	-0.042 d
155.0	0.319 S	-0.272 J	0.006 S	0.234 S	-0.198 J	-0.039 d
150.0	0.298 S	-0.254 J	0.006 S	0.223 S	-0.189 J	-0.036 d
145.0	0.279 S	-0.237 J	0.006 S	0.212 S	-0.179 J	-0.034 d
140.0	0.260 S	-0.221 J	0.006 S	0.201 S	-0.170 J	-0.031 d
133.3	0.236 S	-0.201 J	0.005 S	0.189 S	-0.161 J	-0.028 d
126.7	0.213 S	-0.182 J	0.005 S	0.178 S	-0.151 J	-0.026 d
120.0	0.192 S	-0.164 J	0.005 S	0.167 S	-0.142 J	-0.024 d
113.3	0.172 S	-0.147 J	0.005 S	0.156 S	-0.133 J	-0.022 d
106.7	0.153 S	-0.131 J	0.005 S	0.145 S	-0.123 J	-0.020 d
100.0	0.136 S	-0.116 J	0.004 S	0.134 S	-0.114 J	-0.018 d
93.3	0.120 S	-0.102 J	0.004 S	0.125 S	-0.106 J	-0.016 d
86.7	0.104 S	-0.089 J	0.004 S	0.115 S	-0.098 J	-0.014 d
80.0	0.090 S	-0.077 J	0.004 S	0.105 S	-0.090 J	-0.013 d
73.3	0.077 S	-0.066 J	0.003 S	0.096 S	-0.082 J	-0.011 d
66.7	0.065 S	-0.055 J	0.003 S	0.086 S	-0.073 J	-0.010 d
60.0	0.054 S	-0.046 J	0.003 S	0.077 S	-0.065 J	-0.008 d
53.3	0.044 S	-0.038 J	0.003 S	0.068 S	-0.058 J	-0.007 d
46.7	0.036 S	-0.031 J	0.002 S	0.060 S	-0.051 J	-0.006 d
40.0	0.028 S	-0.024 J	0.002 S	0.051 S	-0.044 J	0.005 h
33.3	0.021 S	-0.018 J	0.002 U	0.043 S	-0.037 J	0.004 h
26.7	0.015 S	-0.013 J	0.001 C	0.034 S	-0.029 J	0.003 h
20.0	0.007 S	-0.006 J	0.001 I	0.025 S	-0.021 J	0.002 h
10.0	0.002 U	-0.002 L	0.001 C	0.013 S	-0.011 J	0.001 h
0.0	0.000 A	0.000 A	0.000 A	0.000 A	0.000 A	0.000 A

MAXIMUM ANTENNA AND REFLECTOR ROTATIONS:

ELEV ft	AZI deg	TYPE *BEAM DEFLECTIONS (deg).....			
			PITCH	YAW	ROLL	TOTAL
260.0	0.0	STD+R	0.416 J	0.148 d	-0.492 S	0.442 J
185.0	0.0	STD+R	0.262 J	0.069 d	-0.309 S	0.270 J

MAXIMUM TENSION IN MAST MEMBERS (kip)

ELEV ft	LEGS	DIAG	HORIZ	BRACE
280.0	-----	-----	0.08 o	0.00 A
	0.03 g	0.12 e		
275.0	-----	-----	0.01 g	0.00 A
	0.00 A	0.36 D		
270.0	-----	-----	0.01 A	0.00 A
	0.51 A	0.43 D		
265.0	-----	-----	0.01 b	0.00 A
	1.48 A	0.47 V		
260.0	-----	-----	0.15 X	0.00 A
	2.64 M	0.84 D		
255.0	-----	-----	0.03 M	0.00 A
	4.38 A	0.92 D		
250.0	-----	-----	0.00 C	0.00 A
	6.32 A	0.92 V		
245.0	-----	-----	0.03 A	0.00 A
	7.99 A	1.29 D		
240.0	-----	-----	0.19 A	0.00 A
	10.97 A	1.32 D		
235.0	-----	-----	0.07 A	0.00 A
	13.98 A	1.48 D		
230.0	-----	-----	0.02 S	0.00 A
	16.96 A	1.79 D		

19-5171-TJH

225.0	-----		0.07 A	0.00 A
	21.17 A	1.91 D		
220.0	-----		0.14 S	0.00 A
	24.16 A	1.04 A		
215.0	-----		0.06 A	0.00 A
	25.88 A	1.25 X		
210.0	-----		0.01 A	0.00 A
	28.13 A	1.17 X		
205.0	-----		0.06 A	0.00 A
	30.33 A	1.18 X		
200.0	-----		0.00 A	0.00 A
	31.95 A	1.37 A		
195.0	-----		0.04 A	0.00 A
	34.38 A	1.38 S		
190.0	-----		0.03 e	0.00 A
	36.62 A	1.35 X		
185.0	-----		0.03 A	0.00 A
	38.80 A	1.62 X		
180.0	-----		0.03 e	0.00 A
	40.94 A	1.74 F		
175.0	-----		0.03 A	0.00 A
	43.53 A	1.59 X		
170.0	-----		0.02 e	0.00 A
	45.58 A	1.69 F		
165.0	-----		0.02 A	0.00 A
	47.94 A	1.59 X		
160.0	-----		0.02 J	0.00 A
	49.94 A	1.68 F		
155.0	-----		0.02 A	0.00 A
	52.13 A	1.62 X		
150.0	-----		0.02 M	0.00 A
	54.07 A	1.70 F		
145.0	-----		0.02 A	0.00 A
	56.16 A	1.66 X		
140.0	-----		0.02 M	0.00 A
	58.34 A	1.83 F		
133.3	-----		0.02 A	0.00 A
	60.96 A	1.82 S		
126.7	-----		0.02 M	0.00 A
	63.39 A	1.89 F		
120.0	-----		0.02 A	0.00 A
	65.92 A	1.92 S		
113.3	-----		0.01 M	0.00 A
	68.32 A	1.97 F		
106.7	-----		0.02 A	0.00 A
	70.78 A	2.01 S		
100.0	-----		0.01 M	0.00 A
	73.12 A	2.07 j		
93.3	-----		0.01 A	0.00 A
	75.49 A	2.14 S		
86.7	-----		0.01 A	0.00 A
	77.78 A	2.18 S		
80.0	-----		0.01 A	0.00 A
	80.13 A	2.26 S		
73.3	-----		0.01 A	0.00 A
	82.42 A	2.32 S		
66.7	-----		0.01 A	0.00 A
	84.74 A	2.39 S		
60.0	-----		0.01 A	0.00 A
	86.96 A	2.45 S		
53.3	-----		0.01 A	0.00 A
	89.14 A	2.53 S		
46.7	-----		0.01 A	0.00 A
	91.29 A	2.59 S		
40.0	-----		0.01 A	0.00 A
	93.47 A	2.67 S		
33.3	-----		0.01 g	0.00 A
	95.61 A	2.74 S		
26.7	-----		0.04 S	0.00 A
	97.76 A	2.83 S		
20.0	-----		0.08 A	0.00 A
	102.56 A	3.49 j		
10.0	-----		0.17 A	0.00 Y
	101.51 A	3.59 j		
0.0	-----		0.00 A	0.00 A

MAXIMUM COMPRESSION IN MAST MEMBERS (kip)

ELEV ft	LEGS	DIAG	HORIZ	BRACE
280.0	----- -0.10 o	----- -0.12 M	-0.08 g	0.00 A
275.0	----- -1.36 s	----- -0.38 D	0.00 o	0.00 A
270.0	----- -2.51 e	----- -0.42 V	0.00 s	0.00 A
265.0	----- -3.62 s	----- -0.50 D	0.00 A	0.00 A
260.0	----- -5.48 s	----- -0.90 G	-0.20 h	0.00 A
255.0	----- -7.45 s	----- -0.86 V	-0.01 s	0.00 A
250.0	----- -9.43 s	----- -0.97 D	-0.01 F	0.00 A
245.0	----- -12.54 s	----- -1.28 V	-0.01 s	0.00 A
240.0	----- -15.68 s	----- -1.41 D	-0.11 G	0.00 A
235.0	----- -19.21 s	----- -1.43 D	-0.04 s	0.00 A
230.0	----- -23.61 s	----- -1.83 D	-0.02 A	0.00 A
225.0	----- -28.27 s	----- -1.91 D	-0.04 s	0.00 A
220.0	----- -31.50 s	----- -1.20 S	-0.23 A	0.00 A
215.0	----- -35.09 s	----- -1.21 X	-0.03 s	0.00 A
210.0	----- -37.70 s	----- -1.24 S	0.00 s	0.00 A
205.0	----- -40.45 s	----- -1.18 X	-0.03 s	0.00 A
200.0	----- -43.69 s	----- -1.46 S	0.00 A	0.00 A
195.0	----- -46.82 s	----- -1.36 X	-0.03 s	0.00 A
190.0	----- -49.55 s	----- -1.43 S	-0.01 M	0.00 A
185.0	----- -52.91 s	----- -1.80 F	-0.03 A	0.00 A
180.0	----- -55.66 s	----- -1.62 X	-0.01 b	0.00 A
175.0	----- -58.63 s	----- -1.72 F	-0.02 A	0.00 A
170.0	----- -61.38 s	----- -1.60 X	-0.01 s	0.00 A
165.0	----- -64.21 s	----- -1.69 F	-0.02 h	0.00 A
160.0	----- -66.93 s	----- -1.63 S	-0.01 s	0.00 A
155.0	----- -69.72 s	----- -1.70 F	-0.01 h	0.00 A
150.0	----- -72.40 s	----- -1.68 S	-0.01 s	0.00 A
145.0	----- -75.14 s	----- -1.73 F	-0.01 s	0.00 A
140.0	----- -78.24 s	----- -1.86 S	-0.01 s	0.00 A
133.3	----- -81.90 s	----- -1.88 F	-0.01 s	0.00 A
126.7	----- -85.46 s	----- -1.94 S	-0.01 s	0.00 A
120.0	----- -89.06 s	----- -1.97 S	-0.01 s	0.00 A
113.3	----- -92.61 s	----- -2.04 S	-0.01 s	0.00 A
106.7	----- -96.18 s	----- -2.07 S	-0.01 s	0.00 A
100.0	----- -99.74 s	----- -2.15 S	-0.01 s	0.00 A
93.3	----- -103.36 s	----- -2.19 S	-0.01 s	0.00 A
86.7	-----	-----	-0.01 s	0.00 A

19-5171-TJH

80.0	-106.97 s	-2.27 s	-0.01 s	0.00 A
73.3	-110.60 s	-2.33 s	-0.01 s	0.00 A
66.7	-114.23 s	-2.40 s	-0.01 s	0.00 A
60.0	-117.87 s	-2.45 s	-0.01 s	0.00 A
53.3	-121.58 s	-2.54 s	-0.01 s	0.00 A
46.7	-125.36 s	-2.60 s	0.00 s	0.00 A
40.0	-129.15 s	-2.67 s	0.00 s	0.00 A
33.3	-132.97 s	-2.74 s	-0.02 C	0.00 A
26.7	-136.80 s	-2.79 s	-0.07 A	0.00 A
20.0	-140.63 s	-2.83 U	-0.04 s	0.00 A
10.0	-147.40 s	-3.80 s	-0.25 s	0.00 G
0.0	-148.44 s	-3.91 s	0.00 A	0.00 A

MAXIMUM INDIVIDUAL FOUNDATION LOADS: (kip)

NORTH	LOAD EAST	COMPONENTS DOWN	UPLIFT	TOTAL SHEAR
12.59 s	10.65 e	153.57 s	-105.06 A	12.59 s

MAXIMUM TOTAL LOADS ON FOUNDATION : (kip & kip-ft)

HORIZONTAL			DOWN	OVERTURNING			TORSION
NORTH	EAST	TOTAL @ 0.0		NORTH	EAST	TOTAL @ 0.0	
19.4 S	-16.6 J	19.4 S	65.0 X	2769.9 S	-2364.1 J	2769.9 S	9.1 h

MAT FOUNDATION DESIGN BY SABRE TOWERS & POLES

Tower Description 280' S3R Series SD
 Customer VERIZON WIRELESS
 Project Number 19-5171-TJH
 Date 12/13/2018
 Engineer NM

Overall Loads:			
Factored Moment (ft-kips)	8767.62		
Factored Axial (kips)	189.36		
Factored Shear (kips)	61.54		
Individual Leg Loads:			
Factored Uplift (kips)	382.00		
Factored Download (kips)	444.00		
Factored Shear (kips)	38.00		
		Tower eccentric from mat (ft)=	2
Width of Tower (ft)	24.25	Allowable Bearing Pressure (ksf)	3.00
Ultimate Bearing Pressure	9.00	Safety Factor	3.00
Bearing Φ s	0.75		
Bearing Design Strength (ksf)	6.75	Max. Factored Net Bearing Pressure (ksf)	4.49
Water Table Below Grade (ft)	999		
Width of Mat (ft)	31	Minimum Mat Width (ft)	30.08
Thickness of Mat (ft)	1.5		
Depth to Bottom of Slab (ft)	6		
Bolt Circle Diameter (in)	10		
Effective Anchor Bolt Embedment	52.625	Minimum Pier Diameter (ft)	2.17
Diameter of Pier (ft)	3.5	Equivalent Square b (ft)	3.10
Ht. of Pier Above Ground (ft)	0.5		
Ht. of Pier Below Ground (ft)	4.5		
Quantity of Bars in Mat	59		
Bar Diameter in Mat (in)	1.128		
Area of Bars in Mat (in ²)	58.96		
Spacing of Bars in Mat (in)	6.29	Recommended Spacing (in)	6 to 12
Quantity of Bars Pier	18		
Bar Diameter in Pier (in)	0.875		
Tie Bar Diameter in Pier (in)	0.5	Minimum Pier A _s (in ²)	6.93
Spacing of Ties (in)	4	Recommended Spacing (in)	5 to 12
Area of Bars in Pier (in ²)	10.82		
Spacing of Bars in Pier (in)	5.93		
f'c (ksi)	4.5		
fy (ksi)	60		
Unit Wt. of Soil (kcf)	0.12		
Unit Wt. of Concrete (kcf)	0.15		
Volume of Concrete (yd ³)	58.73		

MAT FOUNDATION DESIGN BY SABRE TOWERS & POLES (CONTINUED)

Two-Way Shear:

Average d (in)	13.872		
ϕv_c (ksi)	0.201	v_u (ksi)	0.158
$\phi v_c = \phi(2 + 4/\beta_c)f_c^{1/2}$	0.302		
$\phi v_c = \phi(\alpha_s d/b_o + 2)f_c^{1/2}$	0.237		
$\phi v_c = \phi 4f_c^{1/2}$	0.201		
Shear perimeter, b_o (in)	204.37		
β_c	1		

Stability:

Overturning Design Strength (ft-k)	11045.8	Factored Overturning Moment (ft-k)	9167.6
------------------------------------	---------	------------------------------------	--------

One-Way Shear:

ϕV_c (kips)	519.3	V_u (kips)	509.1
-------------------	-------	--------------	-------

Pier Design:

Design Tensile Strength (kips)	584.5	T_u (kips)	382.0
--------------------------------	-------	--------------	-------

Shear:

ϕ	0.75		
V_c (kips)	84.9		
V_s (kips)	197.9	$V_{s,max}$ (kips)	757.3
ϕV_n (kips)	212.1	V_u (kips)	38.0
Maximum Spacing (in)	11.15	(Only if Shear Ties are Required)	
Actual Hook Development (in)	12.74	Req'd Hook Development l_{dh} (in) - Tension	10.96
		Req'd Hook Development l_{dc} (in) - Compression	11.81

Anchor Bolt Pull-Out:

$N_{ua} / \phi N_n$	0.81	$V_{ua} / \phi V_n$	0.17
Pier Rebar Development Length (in)	41.18	Required Length of Development (in)	23.48

Flexure in Slab:

ϕM_n (ft-kips)	3350.7	M_u (ft-kips)	3335.0
a (in)	2.49		
Steel Ratio	0.01143		
β_1	0.825		
Maximum Steel Ratio (ρ_t)	0.0197		
Minimum Steel Ratio	0.0018		
Rebar Development in Pad (in)	93.61	Required Development in Pad (in)	16.77

Condition	1 is OK, 0 Fails
Minimum Mat Width	1
Maximum Soil Bearing Pressure	1
Pier Area of Steel	1
Pier Shear	1
Two-Way Shear	1
Overturning	1
Anchor Bolt Pull-Out	1
Flexure	1
Steel Ratio	1
Interaction Diagram Visual Check	1
One-Way Shear	1
Hook Development	1
Minimum Mat Depth	1
Anchor Bolt Punching Shear	1

DRILLED STRAIGHT PIER DESIGN BY SABRE TOWERS & POLES

Tower Description 280' S3R Series SD
 Customer Name VERIZON WIRELESS
 Job Number 19-5171-TJH
 Date 12/13/2018
 Engineer NM

Factored Uplift (kips)	382
Factored Download (kips)	444
Factored Shear (kips)	38
Ultimate Bearing Pressure	12
Bearing ϕ_s	0.75
Bearing Design Strength (ksf)	9
Water Table Below Grade (ft)	999
Bolt Circle Diameter (in)	10
Effective Anchor Bolt Embedment	52.625
Pier Diameter (ft)	4
Ht. Above Ground (ft)	0.5
Pier Length Below Ground (ft)	33.5
Quantity of Bars	12
Bar Diameter (in)	1.128
Area of Bars (in ²)	11.99
Spacing of Bars (in)	10.32
Tie Bar Diameter (in)	0.5
Spacing of Ties (in)	12
f'_c (ksi)	4.5
f_y (ksi)	60

Minimum Pier Diameter (ft) 2.17

Minimum Area of Steel (in²) 9.05

Unit Wt. of Concrete (kcf)	0.15
Download Friction ϕ_s	0.75
Uplift Friction ϕ_s	0.75
Volume of Concrete (yd ³)	15.82
Skin Friction Factor for Uplift	1
Ignore Bottom Length in Download?	<input type="checkbox"/>

Length to Ignore Download (ft) **0**

Depth at Bottom of Layer (ft)	Ult. Skin Friction (ksf)	(Ult. Skin Friction)*(Uplift Factor)	γ (kcf)
6	0.00	0.00	0.12
23.5	1.20	1.20	0.12
28.5	1.20	1.20	0.13
35	2.00	2.00	0.13
0	0.00	0.00	0
0	0.00	0.00	0
0	0.00	0.00	0
0	0.00	0.00	0
0	0.00	0.00	0
0	0.00	0.00	0

DRILLED STRAIGHT PIER DESIGN BY SABRE TOWERS & POLES (CONTINUED)

Download:

Factored Net Weight of Concrete (kips)	14.8
Bearing Design Strength (kips)	113.1
Skin Friction Design Strength (kips)	348.7
Download Design Strength (kips)	461.8

Factored Net Download (kips) 458.8

Uplift:

Nominal Skin Friction (kips)	465.0
W _c , Weight of Concrete (kips)	64.1
W _R , Soil Resistance (kips)	2070.4
$\phi_s W_r + 0.9W_c$ (kips)	1610.5
Uplift Design Strength (kips)	406.4

Factored Uplift (kips) 382.0

Tension:

Design Tensile Strength (kips)	647.6
--------------------------------	-------

T_u (kips) 382.0

Shear:

ϕ	0.75
V _c (kips)	142.9
V _s (kips)	75.4
ϕV_n (kips)	163.7

V_{s,max} (kips) 989.2
 V_u (kips) 38.0

Anchor Bolt Pull-Out:

N _{ua} / ϕN_n	0.81
Rebar Development Length (in)	39.17

V_{ua} / ϕV_n 0.17
 Required Length of Development (in) 30.27

Condition	1 is OK, 0 Fails
Download	1
Uplift	1
Area of Steel	1
Shear	1
Anchor Bolt Pull-Out	1
Interaction Diagram Visual Check	1

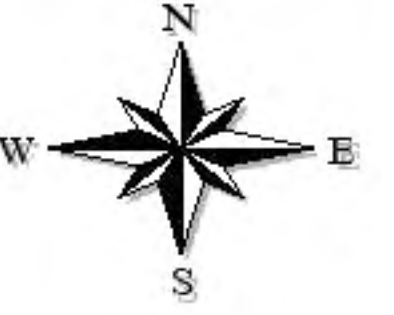

KENTUCKY RSA No. 1
PARTNERSHIP d/b/a

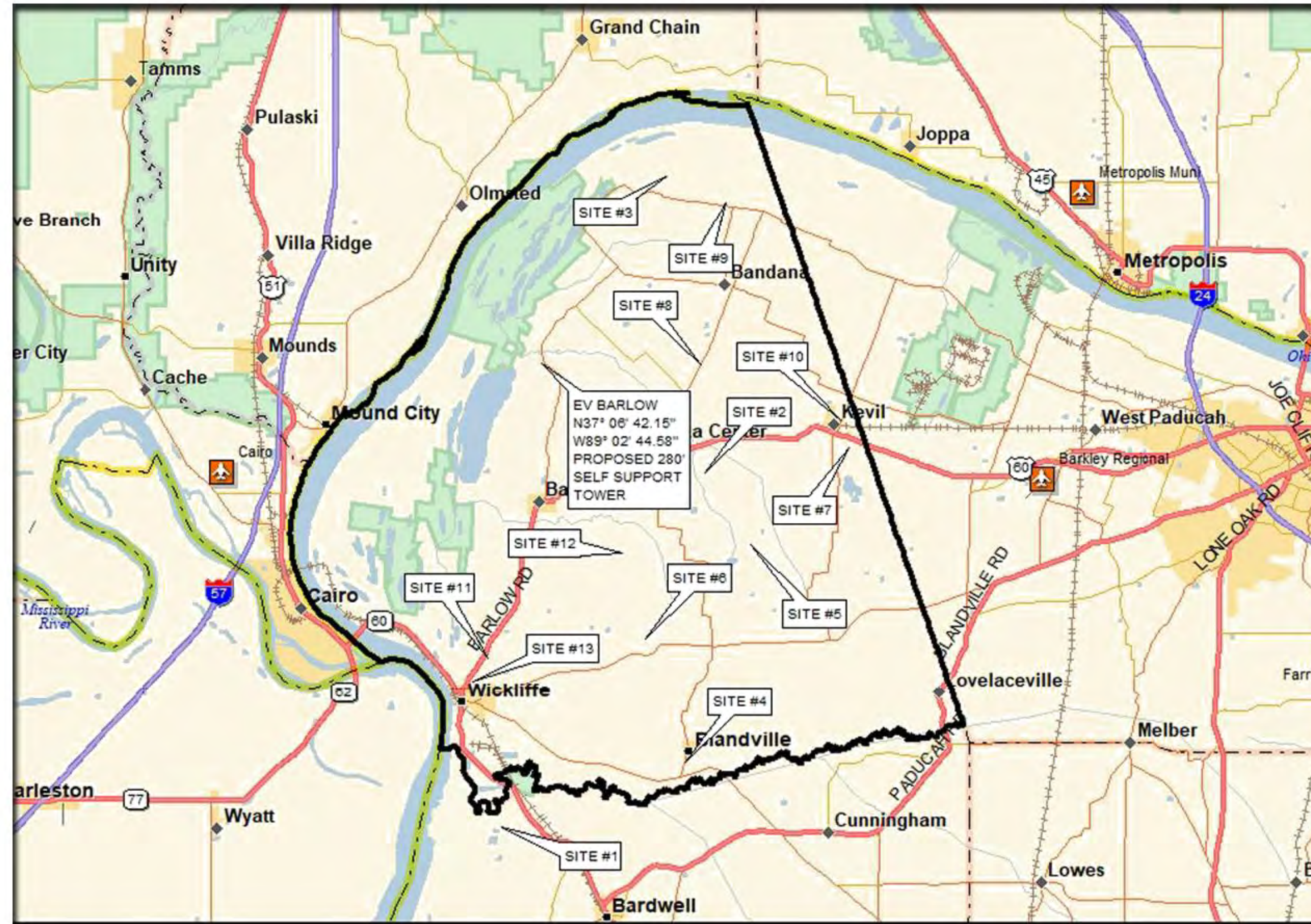

MAP NOT TO SCALE

BALLARD COUNTY, KENTUCKY VERIZON WIRELESS TOWER SITE EV BARLOW TOWER LOCATION EXHIBIT

BROADCAST AND TRANSMIT STRUCTURE LOCATIONS
DEPICTED ARE ALL KNOWN STRUCTURE SITES THAT
HAVE BEEN REGISTERED WITH THE FEDERAL
COMMUNICATIONS COMMISSION WITHIN 1/2 MILE
OF THE LIMITS OF BALLARD COUNTY ON OR BEFORE
JANUARY 31, 2022

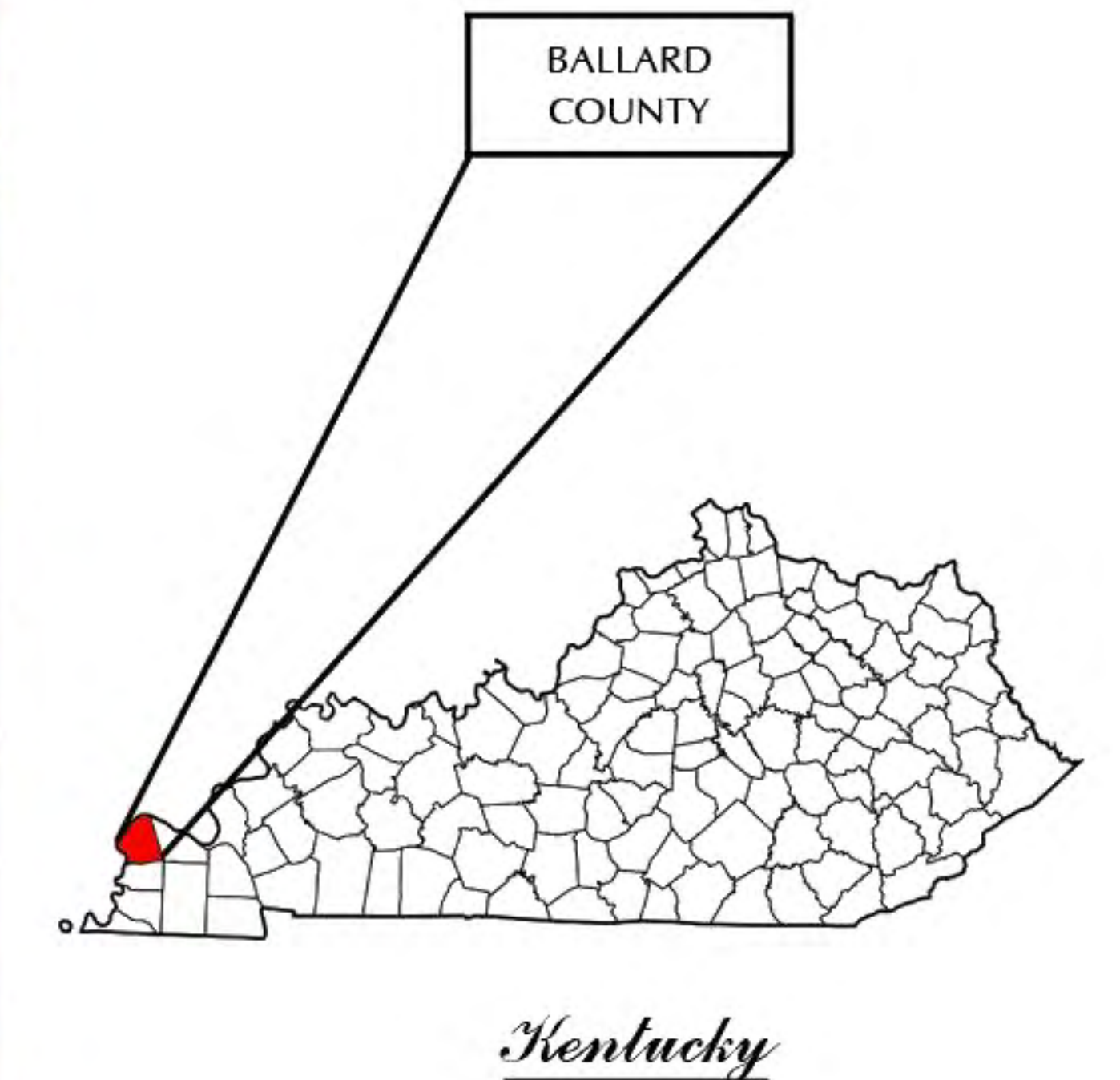

- SITE #1: FCC# 1030662 CROWN CASTLE GT COMPANY, LLC N36°54'35.5", W89°04'01.6"
- SITE #2: FCC# 1030664 CROWN CASTLE GT COMPANY, LLC N37°03'51.4", W88°57'23.6"
- SITE #3: FCC# 1044387 AMERICAM FAMILY ASSOCIATION N37°11'36.0", W88°58'40.0"
- SITE #4: FCC# 1044596 WITHERS BROADCASTING COMPANY OF PADUCAH, LLC N36°56'17.0", W88°58'01.0"
- SITE #5: FCC# 1061534 SBA PROPERTIES, LLC N37°01'59.6", W88°55'53.8"
- SITE #6: FCC# 1222068 AMERICAN FAMILY ASSOCIATION N36°59'32.1", W88°59'19.2"
- SITE #7: FCC# 1229412 TOWERS III, LLC N37°04'30.1", W88°52'42.7"

- SITE #8: FCC# 1244919 CCATT, LLC N37°06'39.7", W88°57'32.4"
- SITE #9: FCC# 1252613 KENTUCKY RSA NO. 1 PARTNERSHIP N37°10'55.4", W88°56'43.7"
- SITE #10: FCC# 1265272 TV6 HOLDINGS, LLC N37°05'12.6", W88°52'56.7"
- SITE #11: FCC# 1265530 KENTUCKY RSA NO. 1 PARTNERSHIP N36°59'01.1", W89°04'29.2"
- SITE #12: FCC# 1313667 KENTUCKY RSA NO. 1 PARTNERSHIP N37°01'45.6", W89°00'07.6"
- SITE #13: FCC# 1318625 KENTUCKY STATE POLICE N36°58'24.9", W89°04'58.4"



Mail Processing Center
 Federal Aviation Administration
 Southwest Regional Office
 Obstruction Evaluation Group
 10101 Hillwood Parkway
 Fort Worth, TX 76177

Aeronautical Study No.
 2018-ASO-17808-OE

Issued Date: 10/01/2018

Network Regulatory
 Kentucky RSA No. 1 Partnership
 5055 North Point Pkwy
 Alpharetta, GA 30005

**** DETERMINATION OF NO HAZARD TO AIR NAVIGATION ****

The Federal Aviation Administration has conducted an aeronautical study under the provisions of 49 U.S.C., Section 44718 and if applicable Title 14 of the Code of Federal Regulations, part 77, concerning:

Structure: Antenna Tower EV Barlow - B (2580839)
 Location: Barlow, KY
 Latitude: 37-06-42.14N NAD 83
 Longitude: 89-02-44.58W
 Heights: 364 feet site elevation (SE)
 285 feet above ground level (AGL)
 649 feet above mean sea level (AMSL)

This aeronautical study revealed that the structure does not exceed obstruction standards and would not be a hazard to air navigation provided the following condition(s), if any, is(are) met:

As a condition to this Determination, the structure is to be marked/lighted in accordance with FAA Advisory circular 70/7460-1 L Change 2, Obstruction Marking and Lighting, a med-dual system - Chapters 4,8(M-Dual),&12.

Any failure or malfunction that lasts more than thirty (30) minutes and affects a top light or flashing obstruction light, regardless of its position, should be reported immediately to (877) 487-6867 so a Notice to Airmen (NOTAM) can be issued. As soon as the normal operation is restored, notify the same number.

It is required that FAA Form 7460-2, Notice of Actual Construction or Alteration, be e-filed any time the project is abandoned or:

- At least 10 days prior to start of construction (7460-2, Part 1)
- Within 5 days after the construction reaches its greatest height (7460-2, Part 2)

This determination expires on 04/01/2020 unless:

- (a) the construction is started (not necessarily completed) and FAA Form 7460-2, Notice of Actual Construction or Alteration, is received by this office.
- (b) extended, revised, or terminated by the issuing office.

- (c) the construction is subject to the licensing authority of the Federal Communications Commission (FCC) and an application for a construction permit has been filed, as required by the FCC, within 6 months of the date of this determination. In such case, the determination expires on the date prescribed by the FCC for completion of construction, or the date the FCC denies the application.

NOTE: REQUEST FOR EXTENSION OF THE EFFECTIVE PERIOD OF THIS DETERMINATION MUST BE E-FILED AT LEAST 15 DAYS PRIOR TO THE EXPIRATION DATE. AFTER RE-EVALUATION OF CURRENT OPERATIONS IN THE AREA OF THE STRUCTURE TO DETERMINE THAT NO SIGNIFICANT AERONAUTICAL CHANGES HAVE OCCURRED, YOUR DETERMINATION MAY BE ELIGIBLE FOR ONE EXTENSION OF THE EFFECTIVE PERIOD.

This determination is based, in part, on the foregoing description which includes specific coordinates, heights, frequency(ies) and power. Any changes in coordinates, heights, and frequencies or use of greater power, except those frequencies specified in the Colo Void Clause Coalition; Antenna System Co-Location; Voluntary Best Practices, effective 21 Nov 2007, will void this determination. Any future construction or alteration, including increase to heights, power, or the addition of other transmitters, requires separate notice to the FAA. This determination includes all previously filed frequencies and power for this structure.

If construction or alteration is dismantled or destroyed, you must submit notice to the FAA within 5 days after the construction or alteration is dismantled or destroyed.

This determination does include temporary construction equipment such as cranes, derricks, etc., which may be used during actual construction of the structure. However, this equipment shall not exceed the overall heights as indicated above. Equipment which has a height greater than the studied structure requires separate notice to the FAA.

This determination concerns the effect of this structure on the safe and efficient use of navigable airspace by aircraft and does not relieve the sponsor of compliance responsibilities relating to any law, ordinance, or regulation of any Federal, State, or local government body.

A copy of this determination will be forwarded to the Federal Communications Commission (FCC) because the structure is subject to their licensing authority.

If we can be of further assistance, please contact our office at (718) 553-2611, or angelique.eersteling@faa.gov. On any future correspondence concerning this matter, please refer to Aeronautical Study Number 2018-ASO-17808-OE.

Signature Control No: 381530823-386435140
Angelique Eersteling
Technician

(DNE)

Attachment(s)
Frequency Data
Map(s)

cc: FCC

Frequency Data for ASN 2018-ASO-17808-OE

LOW FREQUENCY	HIGH FREQUENCY	FREQUENCY UNIT	ERP	ERP UNIT
6	7	GHz	55	dBW
6	7	GHz	42	dBW
10	11.7	GHz	55	dBW
10	11.7	GHz	42	dBW
17.7	19.7	GHz	55	dBW
17.7	19.7	GHz	42	dBW
21.2	23.6	GHz	55	dBW
21.2	23.6	GHz	42	dBW
614	698	MHz	1000	W
614	698	MHz	2000	W
698	806	MHz	1000	W
806	901	MHz	500	W
806	824	MHz	500	W
824	849	MHz	500	W
851	866	MHz	500	W
869	894	MHz	500	W
896	901	MHz	500	W
901	902	MHz	7	W
929	932	MHz	3500	W
930	931	MHz	3500	W
931	932	MHz	3500	W
932	932.5	MHz	17	dBW
935	940	MHz	1000	W
940	941	MHz	3500	W
1670	1675	MHz	500	W
1710	1755	MHz	500	W
1850	1910	MHz	1640	W
1850	1990	MHz	1640	W
1930	1990	MHz	1640	W
1990	2025	MHz	500	W
2110	2200	MHz	500	W
2305	2360	MHz	2000	W
2305	2310	MHz	2000	W
2345	2360	MHz	2000	W
2496	2690	MHz	500	W

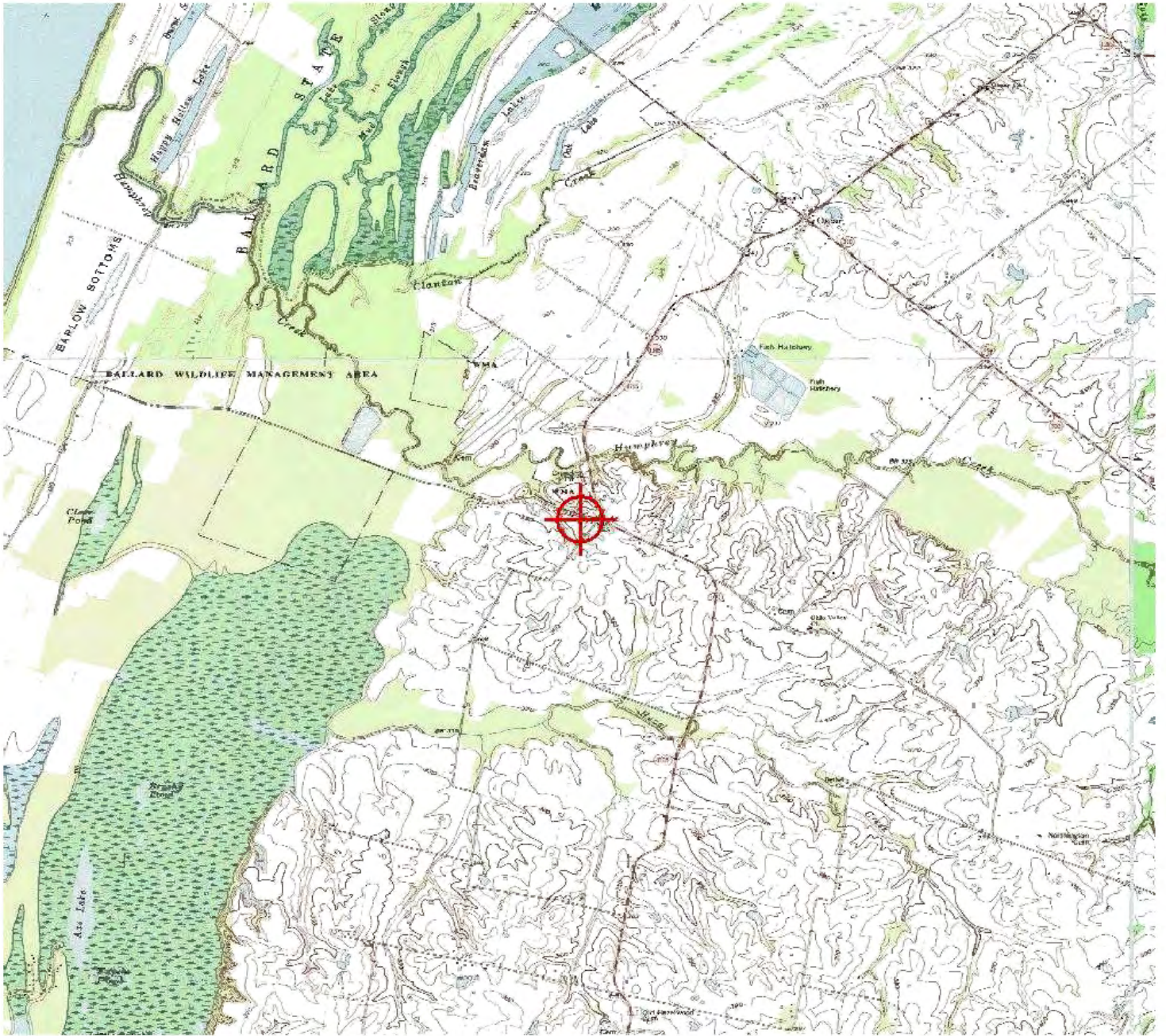



KENTUCKY AIRPORT ZONING COMMISSION

MATTHEW BEVIN
Governor

421 Buttermilk Pike
Covington, KY 41017
www.transportation.ky.gov
859-341-2700

CONSTRUCTION/ALTERATION STATUS REPORT

December 21, 2018

AERONAUTICAL STUDY NUMBER: AS-004-PAH-2018-092

Verizon Wireless Tennessee
Verizon Wireless Tennessee
5055 North Point Pkwy, NP2NE
Alpharetta, GA 30022

This concerns the permit which was issued to you by the Kentucky Airport Zoning Commission on December 21, 2018. This permit is valid for a period of 18 Month(s) from its date of issuance. If construction is not completed within the said 18-Month period, this permit shall lapse and be void, and no work shall be performed without the issuance of a new permit. When appropriate, please indicate the status of the project in the place below and return this letter to John Houlihan, Administrator, Kentucky Airport Zoning Commission, 421 Buttermilk Pike, Covington, KY, 41017. 859-341-2700.

STRUCTURE: Antenna Tower
LOCATION: Barlow, KY
COORDINATES: 37° 6' 42.14" N / 89° 2' 44.58" W
HEIGHT: 285' AGL /649' AMSL

CONSTRUCTION/ALTERATION STATUS

1. The project () is abandoned. () is not abandoned.

2. Construction status is as follows:

Structure reached its greatest height of _____ ft. AGL
_____ ft. AMSL on _____ (date).

Date construction was completed. _____

Type of obstruction marking/painting. _____

Type of obstruction lighting. _____

As built coordinates. _____

Miscellaneous Information. _____

DATE _____

SIGNATURE/TITLE _____



Geotechnical Report and Resistivity

Verizon Wireless EV Barlow

2244 Steve Denton Road
Barlow, Kentucky

August 30, 2018

Prepared For:



Verizon Wireless
250 East 96th Street
Suite 175
Indianapolis, Indiana

Prepared By:



**SUBSURFACE INVESTIGATION &
GEOTECHNICAL RECOMMENDATIONS**

**EV BARLOW – CELL TOWER
2244 STEVE DENTON ROAD
BARLOW, KENTUCKY
A&W PROJECT NO: 18IN0510**

**PREPARED FOR:
GPD GROUP
INDIANAPOLIS, INDIANA**

**PREPARED BY:
ALT & WITZIG ENGINEERING, INC.
GEOTECHNICAL DIVISION**

AUGUST 30, 2018



Alt & Witzig Engineering, Inc.

4105 West 99th Street • Indianapolis • Indiana • 46032
Ph (317) 875-7000 • Fax (317) 876-3705

August 30, 2018

GPD Group
8275 Allison Pointe Trail, Suite 220
Indianapolis, Indiana 46250
ATTN: Ms. Traci Preble

Report of Subsurface Investigation & Geotechnical Recommendations

RE: EV Barlow – Cell Tower
2244 Steve Denton Road
Barlow, Kentucky
Alt & Witzig File: **18IN0510**

Dear Ms. Preble:

In compliance with your request, we have completed a subsurface investigation and geotechnical evaluation for the above referenced project. It is our pleasure to transmit herewith one (1) electronic copy of our report.

The purpose of this subsurface investigation was to determine the various soils profile components and the engineering characteristics of the materials encountered in order to provide information to be used for preparing a foundation for the proposed cellular tower and equipment building.

Project Description

It is anticipated that a new 285-foot tall self-support cell tower will be constructed at this site. A prefabricated equipment building will also be constructed at this site

The site is located west of State Road 1105 and approximately one-hundred (100) feet south of Sallie Crice Road near Barlow, Kentucky (Exhibit 1). The site may be located using the Barlow Quadrangle, Kentucky-Illinois 7½ minute topographic map.

Based upon the project plans provided by GPD to Alt & Witzig Engineering, the ground surface elevation at the tower center is taken to be 348.0' AMSL. All depths referred to in this report and on the Boring Logs are referenced from the existing ground surface.

Offices:

Cincinnati • Columbus • Dayton, Ohio
Evansville • Ft. Wayne • Indianapolis • Lafayette • Merrillville/South Bend, Indiana

***Subsurface Investigation and Foundation Engineering
Construction Materials Testing and Inspection
Environmental Services***

Exhibit 1: 2017 Aerial Photograph with Overlay



Field Methods

The field investigation included a reconnaissance of the project site, performing one (1) soil boring (B-1) for the proposed tower and one (1) soil boring for the equipment building (B-2), performing standard penetration tests, and obtaining soil samples retained in the standard split-spoon sampler. The apparent groundwater level at the boring location was also determined.

The soil boring was performed with an all terrain vehicle-mounted drilling rig equipped with a rotary head. Conventional hollow-stem augers were used to advance the holes. The advancement of the borings was temporarily stopped at regular intervals in order to perform standard penetration tests in accordance with ASTM Procedure D-1586. The standard penetration test involves driving a split spoon soil sampler into the ground by dropping a 140-pound hammer, thirty (30) inches. The number of hammer drops required to advance the split-spoon sampler one (1) foot into the soil is defined as the standard penetration value. The soil samples retained in the split-spoon sampling device as a result of the penetration tests were obtained, classified, and labeled for further laboratory investigation.



Laboratory Investigation

A laboratory investigation was conducted to ascertain additional pertinent engineering characteristics of the subsurface materials at the site of the proposed tower. The laboratory testing program included:

- Visual classification of soils.
- Moisture content determination in accordance with ASTM D-2216.
- Samples of the cohesive soil were frequently tested in unconfined compression by use of a calibrated spring testing machine.
- A pocket penetrometer was used as an aid in determining the strength of the soil.

The values of the unconfined compressive strength as determined on soil samples from the split-spoon sampling must be considered approximate recognizing the manner in which they were obtained since the split-spoon sampling techniques provide a representative but somewhat disturbed soil sample.

Site Specific Subsurface Conditions

At the ground surface, the borings encountered approximately six (6) inches of topsoil. Beneath the topsoil, the borings encountered very soft to stiff silty clays with varying amounts of sand and gravel extending to depths of twenty-three and one-half (23½) feet (Elev. 319.5 feet) in boring B-1 and ten (10) feet (Elev. 338.0 feet) in boring B-2. In boring B-1, these soils transitioned into a hard consistency that extended to a depth of twenty-eight and one-half (28½) feet. At this depth, dry, very dense, clayey sand was encountered to the termination depth of the boring at thirty-seven (37) feet, where auger refusal was encountered. Detailed soil descriptions at the boring location have been included on the *Boring Logs* in the Appendix of this report.

Bedrock

The site is located along the Mississippi Embayment of the Mississippi Alluvial Plain within the Jackson Purchase Region of Kentucky. This part of Kentucky is relatively flat-lying, with numerous lakes, ponds, sloughs, and swamps. Geologic maps published by the US Geological Service indicate the Mississippi Embayment is the northward continuation of the fluvial sediments of the Mississippi River Delta. The current sedimentary area was formed in the Cretaceous and early Cenozoic periods by the filling with sediment of an existing basin. The soils in this region consists primarily of loess. The underlying bedrock in this region consists primarily of limestone formed in the Ordovician period.



Groundwater

Water level observations made during and upon completion of drilling operations yielded dry boreholes. These measurements are noted on the *Boring Logs* presented herewith. The exact location at which water is encountered should be anticipated to fluctuate somewhat depending upon normal seasonal variations in precipitation and surface runoff.

It should be noted that the groundwater level measurement recorded on the individual *Boring Logs* in the Appendix of this report is accurate for the specific date on which the measurements was performed. It must be understood that the groundwater level will fluctuate throughout the year. The *Boring Logs* do not indicate these fluctuations.

Seismic Parameters

An evaluation of the seismic site class has been performed for this site. The State of Kentucky has integrated the 2015 International Building Code into the Indiana Building Code (IBC). The seismic site class is determined by averaging soil conditions within the top 100 feet with respect to the shear wave velocity in accordance with ASCE 7. Our evaluation is based on data obtained for borings performed to depths of 33 feet at this site and information provided by the Indiana Geological Survey for a depth of 100 feet. A detailed report generated by the USGS Earthquake Hazard program (<http://earthquake.usgs.gov/designmaps/us/application.php>) has been attached to this letter. Following are the summarized requested seismic parameters.

Seismic Parameters

Site Soil Classification	Site Class D
MCE Spectral Response Accelerations	$S_s = 2.506$ $S_1 = 0.951$
Site Coefficients	$F_a = 1.0$ $F_v = 1.5$

Geotechnical Recommendations

Information provided by GPD Group indicates that the proposed 285-foot self-support cell tower will be constructed in the general vicinity of soil boring B-1; and an equipment building will be constructed in the general vicinity of boring B-2. Our experience with this type of structure indicates that the structural loads of the tower will be supported by an extended mat foundation or a caisson system and the buildings will be supported by conventional spread footings and continuous wall footings. It is recommended that a representative of Alt & Witzig Engineering, Inc. be on-site to monitor the excavation and inspect the base of the foundations.



Tower Foundation Recommendations

Extended Footing or Extended Mat Foundation

If spread footings are desired, they should be founded at a minimum depth of four (4) feet below existing grade. The soil parameters presented in *Table 1* may be utilized for the design of a shallow foundation.

Table 1: Shallow Foundation Soil Parameters

Soil Description	Depth Below Existing Grade (feet)	Allowable Bearing Pressure (psf) FS=3	Unit Weight (pcf)	C (psf)/Φ (°)	Adhesion (psf)
Silty Clay	4-9	3,000	120	2,000	1250

It is anticipated that lateral wind loads and overturning moments will act on the spread footing. To help resist the overturning moment, it may be necessary to place a larger footing than necessary for bearing capacity. Also, any soil placed above the footing may be considered to help resist overturning moments if compacted to a minimum of 98 percent of the maximum dry density as determined from ASTM D-698 (Standard Proctor).

Depending upon the time of the year that the excavations are made, seepage from surface runoff may occur. Since these foundation materials tend to soften/loosen when exposed to free water, every effort should be made to keep the excavations dry should water be encountered. It is also recommended that concrete for footings be poured as soon as possible after the excavations are complete. A mud mat may be placed to provide the contractors a firm working surface and protect the exposed subgrade soils from softening.

Caissons/Drilled Piers

A caisson type foundation is advantageous to use when it is necessary to resist large overturning moments such as those caused by wind loads against the proposed structure. As an alternative to a shallow foundation system, a caisson type foundation system may be considered to support this tower structure. A straight shaft caisson/drilled pier may be considered. If a caisson or drilled shaft is used to support the structure, it should be designed using the soil parameters provided in *Table 2*.



Table 2: Deep Foundation Soil Parameters

Soil Type	Depth Below Grade (Feet)	Allowable Skin Friction for Gravity Loads SF=2	Design End Bearing Pressure SF=3	Effective Unit Weight (pcf)	C (psf) / Φ (°)
Silty Clay	6 – 23.5	600 psf	NA	120 pcf	2000 psf
Hard Silty Clay	23.5 – 28.5	600 psf	4,000 psf	130 pcf	2000 psf
Clayey Sand	28.5+	1000 psf	4,000 psf	130 pcf	28°

*Skin friction may be utilized in shaft compression and tension. The top one-shaft diameter should be neglected.

Equipment Building Foundation Recommendations

A net allowable bearing pressure of **2,000 psf** is recommended for dimensioning continuous wall footings at this site. The above-suggested bearing pressure is provided assuming the footings will be founded on medium stiff natural soils or properly compacted fill materials at a minimum depth of three (3) feet below grade.

Equipment Building Slab Recommendations

This structure will be a slab-on-grade supported by natural soils and/or compacted fill materials. In those areas where the existing grade is lower than the design floor elevation, a well-compacted structural fill will be necessary to raise the site to the desired grade. The fill material shall consist of INDOT No. 53 Stone.

After the building areas have been raised to the proper elevation, a granular fill should be placed immediately beneath the floor slab. It is recommended that all material placed in the floor slab areas be compacted to a density of 100 percent of maximum dry density in accordance with ASTM D-698. Recommendations for proper filling procedures are presented later in the Appendix of this report.

Statement of Limitations

Our subsurface investigation was conducted in accordance with guidelines set forth in the scope of services and applicable industry standards.

An inherent limitation of any geotechnical engineering study is that conclusions must be drawn on the basis of data collected at a limited number of discrete locations. The geotechnical parameters provided in this report were developed from the information obtained from the test borings that depict subsurface conditions only at these specific locations and on the particular date indicated on the boring logs. Soil conditions at other locations may differ from conditions encountered at these



boring locations and groundwater levels shall be expected to vary with time. The nature and extent of variations between the borings may not become evident until the course of construction.

Often, because of design and construction details that occur on a project, questions rise concerning the soil conditions. If we can give further service in these matters, please contact us at your convenience.

Very truly yours,

Alt & Witzig Engineering, Inc.

A handwritten signature in black ink, appearing to read 'D. M. Shumate', written over a horizontal line.

David M. Shumate
Staff Geologist

A handwritten signature in black ink, appearing to read 'David C. Harness', written in a cursive style.

David C. Harness, P.E.



APPENDIX

Recommended Specifications for Compacted Fills and Backfills

Site Location Map

Boring Location Plan

Boring Logs

General Notes

USGS Design Maps Summary

Custom Soil Resource Report for Ballard and McCracken Counties, Kentucky

RECOMMENDED SPECIFICATIONS FOR COMPACTED FILLS AND BACKFILLS

All fill shall be formed from material free of vegetable matter, rubbish, large rock, and other deleterious material. Prior to placement of fill, a sample of the proposed fill material should be submitted to the soils engineer for his approval. The fill material should be placed in layers not to exceed eight (8) inches in loose thickness and should be sprinkled with water as required to secure specified compactions. Each layer should be uniformly compacted by means of suitable equipment of the type required by the materials composing the fill. Under no circumstances should a bulldozer or similar tracked vehicles be used as compacting equipment. Material containing an excess of water so the specified compaction limits cannot be attained should be spread and dried to a moisture content which will permit proper compaction. All fill should be compacted to the specified percent of the maximum density obtained in accordance with ASTM density Test D-698 (100 percent of maximum dry density below and above the base of footing elevation). Should the results of the in-place density tests indicate that the specified compaction limits are not obtained; the areas represented by such tests should be reworked and retested as required until the specified limits are reached.

SITE LOCATION MAP

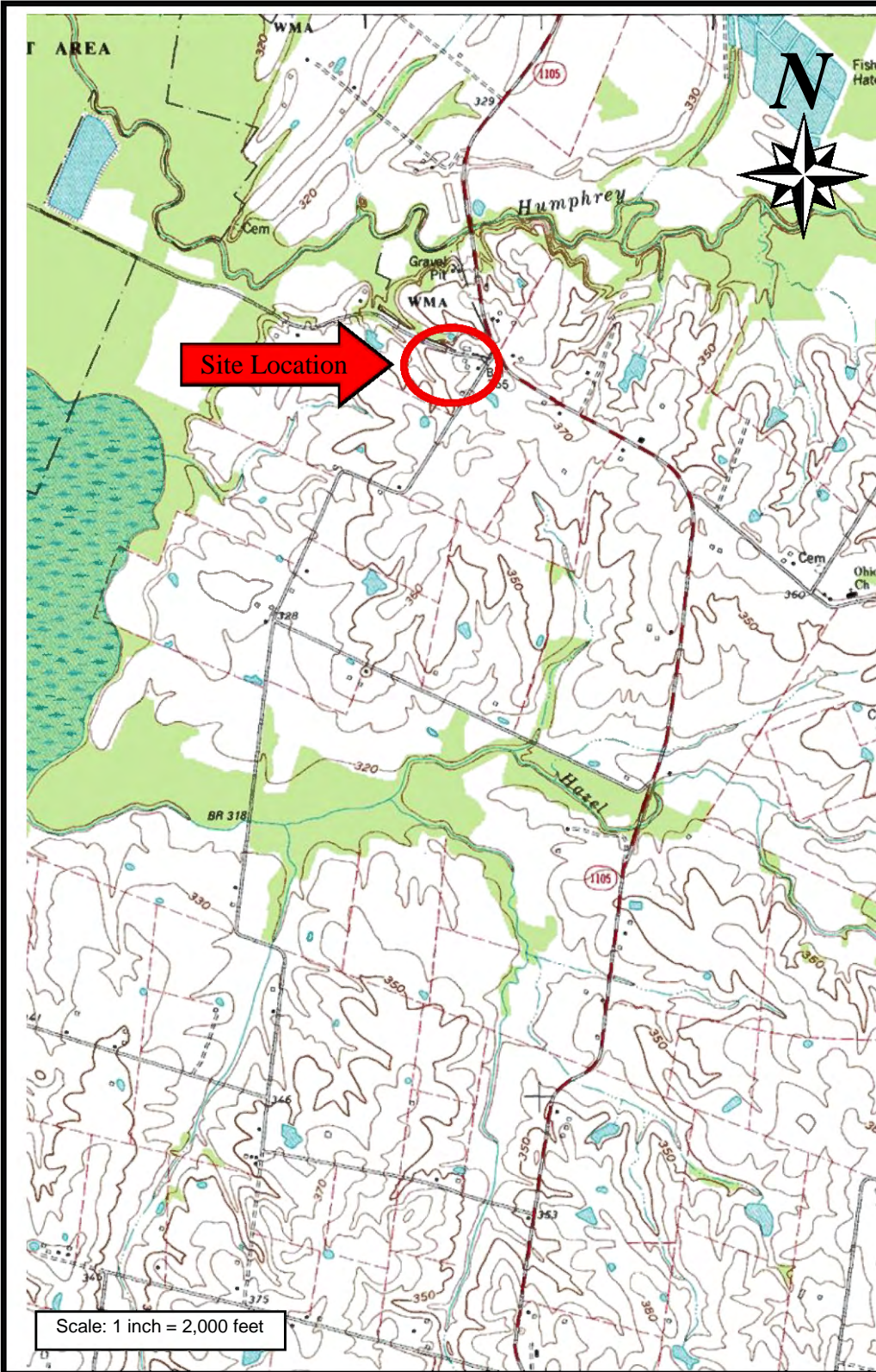

USGS Topographic Map:
Barlow Quadrangle

PROJECT: EV Barlow-Cell Tower
LOCATION: 2244 Steve Denton Road
CLIENT: GPD Group
A&W File No.: 18IN0510

A
W Alt & Witzig Engineering Inc.
4105 W. 99th Street · Carmel, IN 46032
TEL (317)875-7000 · FAX (317) 876-3705
www.altwitzig.com

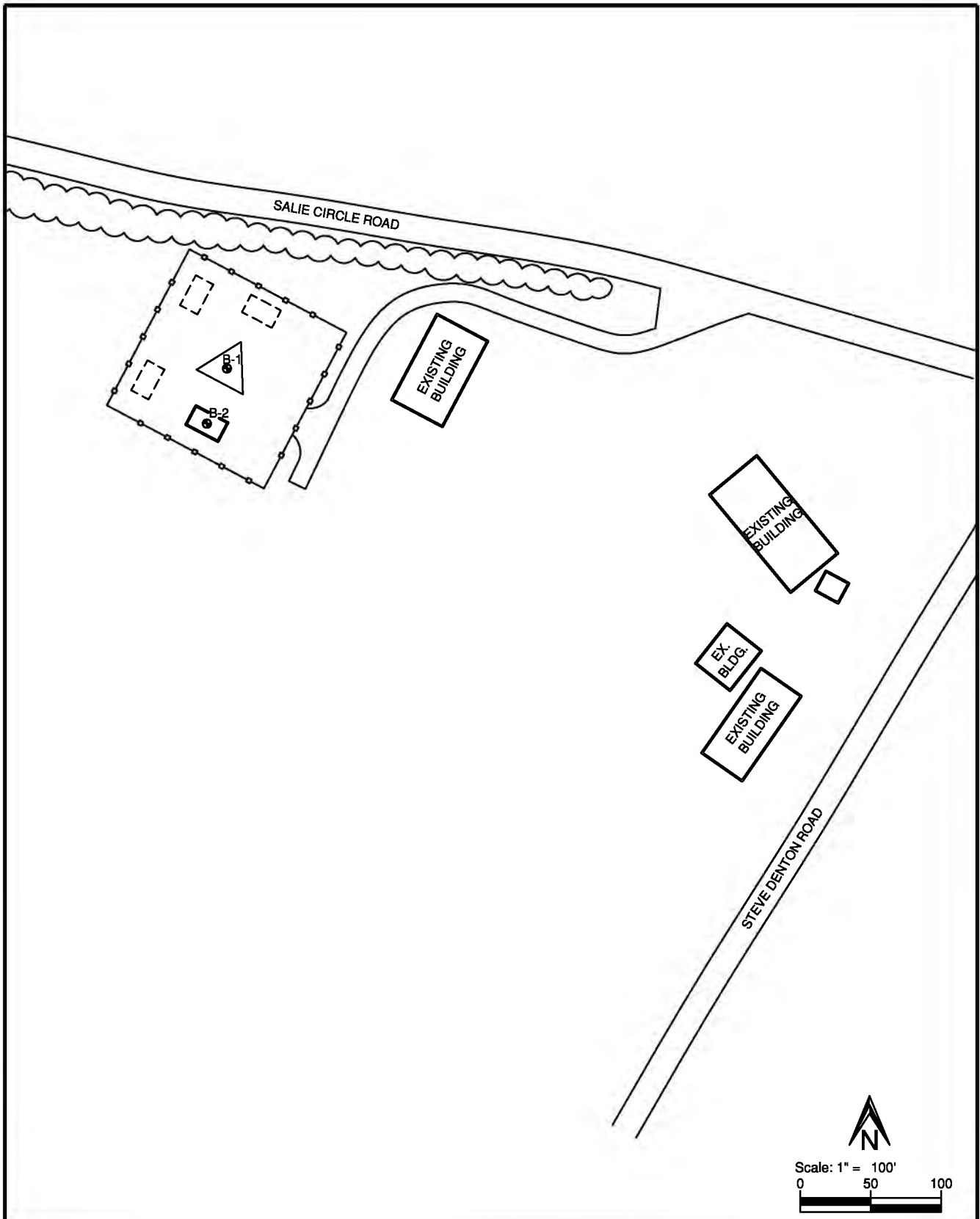

BORING LOCATION PLAN

PROJECT NAME: EV Barlow-Cell Tower
 LOCATION: 2244 Steve Denton Road
 PREPARED FOR: GPD Group
 PROJECT NO: 18IN0510

Project Manager: DS
 Checked By: DH
 Drawn By: JT
 Date: 08/18

AW Alt & Witzig Engineering, Inc.
 4105 West 99th Street • Carmel, IN 46032
 Telephone: (317) 875-7000 • Fax (317) 876-3705



BORING LOG

Alt & Witzig Engineering, Inc.

CLIENT GPD Group
 PROJECT NAME EV Barlow Cell Tower
 PROJECT LOCATION Barlow, Kentucky

BORING # B-1
 ALT & WITZIG FILE # 18IN0510
 Latitude 37.11175 Longitude -89.045767

DRILLING and SAMPLING INFORMATION

Date Started 8/7/18 Hammer Wt. 140 lbs.
 Date Completed 8/7/18 Hammer Drop 30 in.
 Boring Method HSA Spoon Sampler OD 2 in.
 Driller S. Champion Rig Type D-50 Track ATV

TEST DATA

STRATA ELEV.	SOIL CLASSIFICATION	Strata Depth	Depth Scale	Sample No.	Sample Type	Sampler Graphics Recovery Graphics	Ground Water	Standard Penetration Test, N - blows/foot	Qu-tsf Unconfined Compressive Strength	PP-tsf Pocket Penetrometer	Moisture Content % Dry Unit Weight (pcf)	Remarks
347.5	TOPSOIL	0.5		1	SS			9		4.5	17.6	
				2	SS			10		4.0	14.0	
				3	SS			8		3.0	22.6	
			5	4	SS			9		2.5	24.8	
				5	SS			3		1.0	26.5	
	Brown Silty CLAY		10									
				6	SS			7		0.5	26.3	
			15									
				8	SS			13	2.3	2.5	28.5	
			20									
324.5	Brownish Red Silty CLAY with Sand and Gravel	23.5		9	SS			74		2.0	19.2	
			25									
319.5	Brownish Red Clayey SAND with Gravel	28.5		10	SS			86				
			30									
				11	SS			71				
			35									
311.0	End of Boring at 35 feet	37.0										

Sample Type
 SS - Driven Split Spoon
 ST - Pressed Shelby Tube
 CA - Continuous Flight Auger
 RC - Rock Core
 CU - Cuttings
 CT - Continuous Tube

Groundwater
 ○ During Drilling Dry ft.
 ▼ At Completion Dry ft.

Boring Method
 HSA - Hollow Stem Augers
 CFA - Continuous Flight Augers
 DC - Driving Casing
 MD - Mud Drilling



BORING LOG

Alt & Witzig Engineering, Inc.

CLIENT GPD Group
 PROJECT NAME EV Barlow Cell Tower
 PROJECT LOCATION Barlow, Kentucky

BORING # B-2
 ALT & WITZIG FILE # 18IN0510
 Latitude 37.11167 Longitude -89.045823

DRILLING and SAMPLING INFORMATION

Date Started 8/7/18 Hammer Wt. 140 lbs.
 Date Completed 8/7/18 Hammer Drop 30 in.
 Boring Method HSA Spoon Sampler OD 2 in.
 Driller S. Champion Rig Type D-50 Track ATV

TEST DATA

STRATA ELEV.	SOIL CLASSIFICATION	Strata Depth	Depth Scale	Sample No.	Sample Type	Sampler Graphics Recovery Graphics	Ground Water	Standard Penetration Test, N - blows/foot	Qu-tsf Unconfined Compressive Strength	PP-tsf Pocket Penetrometer	Moisture Content % Dry Unit Weight (pcf)	Remarks
347.5	TOPSOIL	0.5		1	SS			11		4.5	15.8	
				2	SS			11		3.0	23.0	
				3	SS			9	1.2	2.5	24.8	
	Brown Silty CLAY		5									
				4	SS			8		2.0	26.5	
				5	SS			3			29.5	
338.0	End of Boring at 10 feet	10.0	10									

Sample Type
 SS - Driven Split Spoon
 ST - Pressed Shelby Tube
 CA - Continuous Flight Auger
 RC - Rock Core
 CU - Cuttings
 CT - Continuous Tube

Groundwater
 ○ During Drilling _____ Dry ft.
 ▼ At Completion _____ Dry ft.

Boring Method
 HSA - Hollow Stem Augers
 CFA - Continuous Flight Augers
 DC - Driving Casing
 MD - Mud Drilling

MATERIAL GRAPHICS LEGEND



CL-ML: USCS Low Plasticity Silty Clay



SC: USCS Clayey Sand



TOPSOIL

SOIL PROPERTY SYMBOLS

N: Standard "N" penetration value. Blows per foot of a 140-lb hammer falling 30" on a 2" O.D. split-spoon.

Qu: Unconfined Compressive Strength, tsf

PP: Pocket Penetrometer, tsf

LL: Liquid Limit, %

PL: Plastic Limit, %

PI: Plasticity Index, %

DRILLING AND SAMPLING SYMBOLS

GROUNDWATER SYMBOLS

- Apparent water level noted while drilling.
- ∇ Apparent water level noted upon completion.
- ▼ Apparent water level noted upon delayed time.

SAMPLER SYMBOLS

⊗ SS: Split Spoon

**RELATIVE DENSITY & CONSISTANCY CLASSIFICATION
(NON-COHESIVE SOILS)**

<u>TERM</u>	<u>BLOWS PER FOOT</u>
Very Loose	0 - 5
Loose	6 - 10
Medium Dense	11 - 30
Dense	31 - 50
Very Dense	>51

**RELATIVE DENSITY & CONSISTANCY CLASSIFICATION
(COHESIVE SOILS)**

<u>TERM</u>	<u>BLOWS PER FOOT</u>
Very Soft	0 - 3
Soft	4 - 5
Medium Stiff	6 - 10
Stiff	11 - 15
Very Stiff	16 - 30
Hard	>31

GENERAL NOTES - PROJECT SPECIFIC - 18IN0510 GINT.GPJ US EVAL.GDT 8/30/18



Alt & Witzig Engineering, Inc.
4105 West 99th St.
Carmel, IN 46032
Telephone: 317-875-7000
Fax:

GENERAL NOTES

Project: EV Barlow Cell Tower

Location: Barlow, Kentucky

Number: 18IN0510

USGS Design Maps Summary Report

User-Specified Input

Report Title 18IN0510
Wed August 15, 2018 15:23:27 UTC

Building Code Reference Document 2012/2015 International Building Code
(which utilizes USGS hazard data available in 2009)

Site Coordinates 37.11175°N, 89.04577°W

Site Soil Classification Site Class D – "Stiff Soil"

Risk Category I/II/III



USGS-Provided Output

$S_S = 2.506 \text{ g}$	$S_{MS} = 2.506 \text{ g}$	$S_{DS} = 1.671 \text{ g}$
$S_1 = 0.951 \text{ g}$	$S_{M1} = 1.426 \text{ g}$	$S_{D1} = 0.951 \text{ g}$

For information on how the S_S and S_1 values above have been calculated from probabilistic (risk-targeted) and deterministic ground motions in the direction of maximum horizontal response, please return to the application and select the "2009 NEHRP" building code reference document.

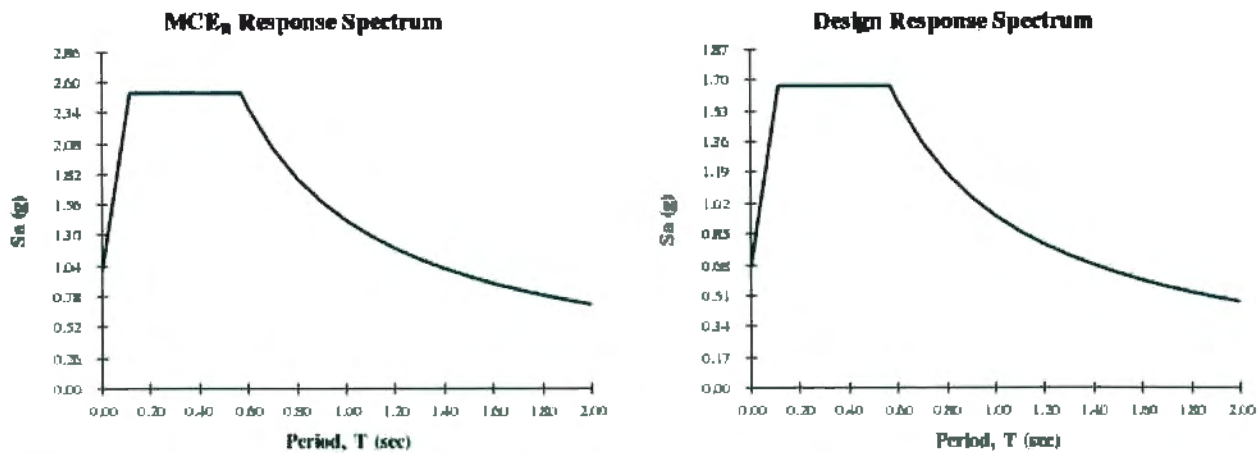

Although this information is a product of the U.S. Geological Survey, we provide no warranty, expressed or implied, as to the accuracy of the data contained therein. This tool is not a substitute for technical subject-matter knowledge.

Design Maps Detailed Report

2012/2015 International Building Code (37.11175°N, 89.04577°W)

Site Class D – “Stiff Soil”, Risk Category I/II/III

Section 1613.3.1 — Mapped acceleration parameters

Note: Ground motion values provided below are for the direction of maximum horizontal spectral response acceleration. They have been converted from corresponding geometric mean ground motions computed by the USGS by applying factors of 1.1 (to obtain S_5) and 1.3 (to obtain S_1). Maps in the 2012/2015 International Building Code are provided for Site Class B. Adjustments for other Site Classes are made, as needed, in Section 1613.3.3.

From [Figure 1613.3.1\(1\)](#) ^[1] $S_5 = 2.506 \text{ g}$ **From [Figure 1613.3.1\(2\)](#) ^[2]** $S_1 = 0.951 \text{ g}$ **Section 1613.3.2 — Site class definitions**

The authority having jurisdiction (not the USGS), site-specific geotechnical data, and/or the default has classified the site as Site Class D, based on the site soil properties in accordance with Section 1613.

2010 ASCE-7 Standard – Table 20.3-1
SITE CLASS DEFINITIONS

Site Class	\bar{v}_s	\bar{N} or \bar{N}_{ch}	\bar{s}_u
A. Hard Rock	>5,000 ft/s	N/A	N/A
B. Rock	2,500 to 5,000 ft/s	N/A	N/A
C. Very dense soil and soft rock	1,200 to 2,500 ft/s	>50	>2,000 psf
D. Stiff Soil	600 to 1,200 ft/s	15 to 50	1,000 to 2,000 psf
E. Soft clay soil	<600 ft/s	<15	<1,000 psf
Any profile with more than 10 ft of soil having the characteristics:			
<ul style="list-style-type: none"> • Plasticity index $PI > 20$, • Moisture content $w \geq 40\%$, and • Undrained shear strength $\bar{s}_u < 500 \text{ psf}$ 			
F. Soils requiring site response analysis in accordance with Section 21.1	See Section 20.3.1		

For SI: 1ft/s = 0.3048 m/s 1lb/ft² = 0.0479 kN/m²

Section 1613.3.3 — Site coefficients and adjusted maximum considered earthquake spectral response acceleration parameters

TABLE 1613.3.3(1)
VALUES OF SITE COEFFICIENT F_s

Site Class	Mapped Spectral Response Acceleration at Short Period				
	$S_s \leq 0.25$	$S_s = 0.50$	$S_s = 0.75$	$S_s = 1.00$	$S_s \geq 1.25$
A	0.8	0.8	0.8	0.8	0.8
B	1.0	1.0	1.0	1.0	1.0
C	1.2	1.2	1.1	1.0	1.0
D	1.6	1.4	1.2	1.1	1.0
E	2.5	1.7	1.2	0.9	0.9
F	See Section 11.4.7 of ASCE 7				

Note: Use straight-line interpolation for intermediate values of S_s

For Site Class = D and $S_s = 2.506$ g, $F_s = 1.000$

TABLE 1613.3.3(2)
VALUES OF SITE COEFFICIENT F_v

Site Class	Mapped Spectral Response Acceleration at 1-s Period				
	$S_1 \leq 0.10$	$S_1 = 0.20$	$S_1 = 0.30$	$S_1 = 0.40$	$S_1 \geq 0.50$
A	0.8	0.8	0.8	0.8	0.8
B	1.0	1.0	1.0	1.0	1.0
C	1.7	1.6	1.5	1.4	1.3
D	2.4	2.0	1.8	1.6	1.5
E	3.5	3.2	2.8	2.4	2.4
F	See Section 11.4.7 of ASCE 7				

Note: Use straight-line interpolation for intermediate values of S_1

For Site Class = D and $S_1 = 0.951$ g, $F_v = 1.500$

Equation (16-37): $S_{MS} = F_a S_s = 1.000 \times 2.506 = 2.506 \text{ g}$

Equation (16-38): $S_{M1} = F_v S_1 = 1.500 \times 0.951 = 1.426 \text{ g}$

Section 1613.3.4 — Design spectral response acceleration parameters

Equation (16-39): $S_{DS} = \frac{2}{3} S_{MS} = \frac{2}{3} \times 2.506 = 1.671 \text{ g}$

Equation (16-40): $S_{D1} = \frac{2}{3} S_{M1} = \frac{2}{3} \times 1.426 = 0.951 \text{ g}$

Section 1613.3.5 — Determination of seismic design category

TABLE 1613.3.5(1)

SEISMIC DESIGN CATEGORY BASED ON SHORT-PERIOD (0.2 second) RESPONSE ACCELERATION

VALUE OF S_{DS}	RISK CATEGORY		
	I or II	III	IV
$S_{DS} < 0.167g$	A	A	A
$0.167g \leq S_{DS} < 0.33g$	B	B	C
$0.33g \leq S_{DS} < 0.50g$	C	C	D
$0.50g \leq S_{DS}$	D	D	D

For Risk Category = I and $S_{DS} = 1.671 g$, Seismic Design Category = D

TABLE 1613.3.5(2)

SEISMIC DESIGN CATEGORY BASED ON 1-SECOND PERIOD RESPONSE ACCELERATION

VALUE OF S_{D1}	RISK CATEGORY		
	I or II	III	IV
$S_{D1} < 0.067g$	A	A	A
$0.067g \leq S_{D1} < 0.133g$	B	B	C
$0.133g \leq S_{D1} < 0.20g$	C	C	D
$0.20g \leq S_{D1}$	D	D	D

For Risk Category = I and $S_{D1} = 0.951 g$, Seismic Design Category = D

Note: When S_1 is greater than or equal to 0.75g, the Seismic Design Category is **E** for buildings in Risk Categories I, II, and III, and **F** for those in Risk Category IV, irrespective of the above.

Seismic Design Category \equiv "the more severe design category in accordance with Table 1613.3.5(1) or 1613.3.5(2)" = E

Note: See Section 1613.3.5.1 for alternative approaches to calculating Seismic Design Category.

References

1. Figure 1613.3.1(1): [https://earthquake.usgs.gov/hazards/designmaps/downloads/pdfs/IBC-2012-Fig1613p3p1\(1\).pdf](https://earthquake.usgs.gov/hazards/designmaps/downloads/pdfs/IBC-2012-Fig1613p3p1(1).pdf)
2. Figure 1613.3.1(2): [https://earthquake.usgs.gov/hazards/designmaps/downloads/pdfs/IBC-2012-Fig1613p3p1\(2\).pdf](https://earthquake.usgs.gov/hazards/designmaps/downloads/pdfs/IBC-2012-Fig1613p3p1(2).pdf)

Custom Soil Resource Report for **Ballard and McCracken Counties, Kentucky**

18IN0510



Preface

Soil surveys contain information that affects land use planning in survey areas. They highlight soil limitations that affect various land uses and provide information about the properties of the soils in the survey areas. Soil surveys are designed for many different users, including farmers, ranchers, foresters, agronomists, urban planners, community officials, engineers, developers, builders, and home buyers. Also, conservationists, teachers, students, and specialists in recreation, waste disposal, and pollution control can use the surveys to help them understand, protect, or enhance the environment.

Various land use regulations of Federal, State, and local governments may impose special restrictions on land use or land treatment. Soil surveys identify soil properties that are used in making various land use or land treatment decisions. The information is intended to help the land users identify and reduce the effects of soil limitations on various land uses. The landowner or user is responsible for identifying and complying with existing laws and regulations.

Although soil survey information can be used for general farm, local, and wider area planning, onsite investigation is needed to supplement this information in some cases. Examples include soil quality assessments (<http://www.nrcs.usda.gov/wps/portal/nrcs/main/soils/health/>) and certain conservation and engineering applications. For more detailed information, contact your local USDA Service Center (<https://offices.sc.egov.usda.gov/locator/app?agency=nrcs>) or your NRCS State Soil Scientist (http://www.nrcs.usda.gov/wps/portal/nrcs/detail/soils/contactus/?cid=nrcs142p2_053951).

Great differences in soil properties can occur within short distances. Some soils are seasonally wet or subject to flooding. Some are too unstable to be used as a foundation for buildings or roads. Clayey or wet soils are poorly suited to use as septic tank absorption fields. A high water table makes a soil poorly suited to basements or underground installations.

The National Cooperative Soil Survey is a joint effort of the United States Department of Agriculture and other Federal agencies, State agencies including the Agricultural Experiment Stations, and local agencies. The Natural Resources Conservation Service (NRCS) has leadership for the Federal part of the National Cooperative Soil Survey.

Information about soils is updated periodically. Updated information is available through the NRCS Web Soil Survey, the site for official soil survey information.

The U.S. Department of Agriculture (USDA) prohibits discrimination in all its programs and activities on the basis of race, color, national origin, age, disability, and where applicable, sex, marital status, familial status, parental status, religion, sexual orientation, genetic information, political beliefs, reprisal, or because all or a part of an individual's income is derived from any public assistance program. (Not all prohibited bases apply to all programs.) Persons with disabilities who require

alternative means for communication of program information (Braille, large print, audiotape, etc.) should contact USDA's TARGET Center at (202) 720-2600 (voice and TDD). To file a complaint of discrimination, write to USDA, Director, Office of Civil Rights, 1400 Independence Avenue, S.W., Washington, D.C. 20250-9410 or call (800) 795-3272 (voice) or (202) 720-6382 (TDD). USDA is an equal opportunity provider and employer.

Contents

Preface	2
Soil Map	5
Soil Map.....	6
Legend.....	7
Map Unit Legend.....	8
Map Unit Descriptions.....	8
Ballard and McCracken Counties, Kentucky.....	10
GrB2—Grenada silt loam, 2 to 6 percent slopes, eroded.....	10
GrC3—Grenada silt loam, 6 to 12 percent slopes, severely eroded.....	11

Soil Map

The soil map section includes the soil map for the defined area of interest, a list of soil map units on the map and extent of each map unit, and cartographic symbols displayed on the map. Also presented are various metadata about data used to produce the map, and a description of each soil map unit.

Custom Soil Resource Report Soil Map



Soil Map may not be valid at this scale.

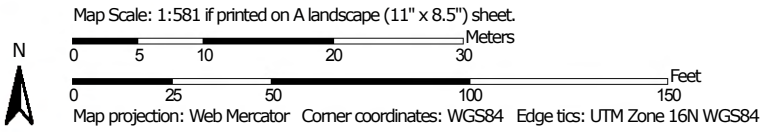



MAP LEGEND

Area of Interest (AOI)

 Area of Interest (AOI)



















Soils

 Soil Map Unit Polygons

 Soil Map Unit Lines

 Soil Map Unit Points

Special Point Features





-  Blowout
-  Borrow Pit
-  Clay Spot
-  Closed Depression
-  Gravel Pit
-  Gravelly Spot
-  Landfill
-  Lava Flow
-  Marsh or swamp
-  Mine or Quarry
-  Miscellaneous Water
-  Perennial Water
-  Rock Outcrop
-  Saline Spot
-  Sandy Spot
-  Severely Eroded Spot
-  Sinkhole
-  Slide or Slip
-  Sodic Spot

-  Spoil Area
-  Stony Spot
-  Very Stony Spot
-  Wet Spot
-  Other
-  Special Line Features

Water Features

 Streams and Canals

Transportation

-  Rails
-  Interstate Highways
-  US Routes
-  Major Roads
-  Local Roads

Background

 Aerial Photography

MAP INFORMATION

The soil surveys that comprise your AOI were mapped at 1:12,000.

Warning: Soil Map may not be valid at this scale.

Enlargement of maps beyond the scale of mapping can cause misunderstanding of the detail of mapping and accuracy of soil line placement. The maps do not show the small areas of contrasting soils that could have been shown at a more detailed scale.

Please rely on the bar scale on each map sheet for map measurements.

Source of Map: Natural Resources Conservation Service
 Web Soil Survey URL:
 Coordinate System: Web Mercator (EPSG:3857)

Maps from the Web Soil Survey are based on the Web Mercator projection, which preserves direction and shape but distorts distance and area. A projection that preserves area, such as the Albers equal-area conic projection, should be used if more accurate calculations of distance or area are required.

This product is generated from the USDA-NRCS certified data as of the version date(s) listed below.

Soil Survey Area: Ballard and McCracken Counties, Kentucky
 Survey Area Data: Version 11, Oct 3, 2017

Soil map units are labeled (as space allows) for map scales 1:50,000 or larger.

Date(s) aerial images were photographed: Sep 13, 2011—Oct 7, 2011

The orthophoto or other base map on which the soil lines were compiled and digitized probably differs from the background imagery displayed on these maps. As a result, some minor shifting of map unit boundaries may be evident.

Map Unit Legend

Map Unit Symbol	Map Unit Name	Acres in AOI	Percent of AOI
GrB2	Grenada silt loam, 2 to 6 percent slopes, eroded	0.2	21.8%
GrC3	Grenada silt loam, 6 to 12 percent slopes, severely eroded	0.9	78.2%
Totals for Area of Interest		1.1	100.0%

Map Unit Descriptions

The map units delineated on the detailed soil maps in a soil survey represent the soils or miscellaneous areas in the survey area. The map unit descriptions, along with the maps, can be used to determine the composition and properties of a unit.

A map unit delineation on a soil map represents an area dominated by one or more major kinds of soil or miscellaneous areas. A map unit is identified and named according to the taxonomic classification of the dominant soils. Within a taxonomic class there are precisely defined limits for the properties of the soils. On the landscape, however, the soils are natural phenomena, and they have the characteristic variability of all natural phenomena. Thus, the range of some observed properties may extend beyond the limits defined for a taxonomic class. Areas of soils of a single taxonomic class rarely, if ever, can be mapped without including areas of other taxonomic classes. Consequently, every map unit is made up of the soils or miscellaneous areas for which it is named and some minor components that belong to taxonomic classes other than those of the major soils.

Most minor soils have properties similar to those of the dominant soil or soils in the map unit, and thus they do not affect use and management. These are called noncontrasting, or similar, components. They may or may not be mentioned in a particular map unit description. Other minor components, however, have properties and behavioral characteristics divergent enough to affect use or to require different management. These are called contrasting, or dissimilar, components. They generally are in small areas and could not be mapped separately because of the scale used. Some small areas of strongly contrasting soils or miscellaneous areas are identified by a special symbol on the maps. If included in the database for a given area, the contrasting minor components are identified in the map unit descriptions along with some characteristics of each. A few areas of minor components may not have been observed, and consequently they are not mentioned in the descriptions, especially where the pattern was so complex that it was impractical to make enough observations to identify all the soils and miscellaneous areas on the landscape.

The presence of minor components in a map unit in no way diminishes the usefulness or accuracy of the data. The objective of mapping is not to delineate pure taxonomic classes but rather to separate the landscape into landforms or landform segments that have similar use and management requirements. The delineation of such segments on the map provides sufficient information for the

Custom Soil Resource Report

development of resource plans. If intensive use of small areas is planned, however, onsite investigation is needed to define and locate the soils and miscellaneous areas.

An identifying symbol precedes the map unit name in the map unit descriptions. Each description includes general facts about the unit and gives important soil properties and qualities.

Soils that have profiles that are almost alike make up a *soil series*. Except for differences in texture of the surface layer, all the soils of a series have major horizons that are similar in composition, thickness, and arrangement.

Soils of one series can differ in texture of the surface layer, slope, stoniness, salinity, degree of erosion, and other characteristics that affect their use. On the basis of such differences, a soil series is divided into *soil phases*. Most of the areas shown on the detailed soil maps are phases of soil series. The name of a soil phase commonly indicates a feature that affects use or management. For example, Alpha silt loam, 0 to 2 percent slopes, is a phase of the Alpha series.

Some map units are made up of two or more major soils or miscellaneous areas. These map units are complexes, associations, or undifferentiated groups.

A *complex* consists of two or more soils or miscellaneous areas in such an intricate pattern or in such small areas that they cannot be shown separately on the maps. The pattern and proportion of the soils or miscellaneous areas are somewhat similar in all areas. Alpha-Beta complex, 0 to 6 percent slopes, is an example.

An *association* is made up of two or more geographically associated soils or miscellaneous areas that are shown as one unit on the maps. Because of present or anticipated uses of the map units in the survey area, it was not considered practical or necessary to map the soils or miscellaneous areas separately. The pattern and relative proportion of the soils or miscellaneous areas are somewhat similar. Alpha-Beta association, 0 to 2 percent slopes, is an example.

An *undifferentiated group* is made up of two or more soils or miscellaneous areas that could be mapped individually but are mapped as one unit because similar interpretations can be made for use and management. The pattern and proportion of the soils or miscellaneous areas in a mapped area are not uniform. An area can be made up of only one of the major soils or miscellaneous areas, or it can be made up of all of them. Alpha and Beta soils, 0 to 2 percent slopes, is an example.

Some surveys include *miscellaneous areas*. Such areas have little or no soil material and support little or no vegetation. Rock outcrop is an example.

Ballard and McCracken Counties, Kentucky

GrB2—Grenada silt loam, 2 to 6 percent slopes, eroded

Map Unit Setting

National map unit symbol: 2wn5t
Elevation: 310 to 640 feet
Mean annual precipitation: 52 to 62 inches
Mean annual air temperature: 48 to 69 degrees F
Frost-free period: 175 to 244 days
Farmland classification: All areas are prime farmland

Map Unit Composition

Grenada, eroded, and similar soils: 90 percent
Minor components: 10 percent
Estimates are based on observations, descriptions, and transects of the mapunit.

Description of Grenada, Eroded

Setting

Landform: Ridges
Landform position (two-dimensional): Shoulder
Landform position (three-dimensional): Nose slope
Down-slope shape: Convex
Across-slope shape: Linear
Parent material: Fine-silty noncalcareous loess

Typical profile

Ap - 0 to 5 inches: silt loam
Bw - 5 to 21 inches: silt loam
E - 21 to 28 inches: silt loam
Btx/E - 28 to 38 inches: silt loam
Btx - 38 to 80 inches: silt loam

Properties and qualities

Slope: 2 to 6 percent
Depth to restrictive feature: 17 to 36 inches to fragipan
Natural drainage class: Moderately well drained
Runoff class: Medium
Capacity of the most limiting layer to transmit water (Ksat): Moderately low to moderately high (0.06 to 0.20 in/hr)
Depth to water table: About 18 to 32 inches
Frequency of flooding: None
Frequency of ponding: None
Available water storage in profile: Moderate (about 6.0 inches)

Interpretive groups

Land capability classification (irrigated): None specified
Land capability classification (nonirrigated): 2e
Hydrologic Soil Group: C
Ecological site: Northern Loess Fragipan Upland - PROVISIONAL (F134XY012AL)
Hydric soil rating: No

Minor Components

Calloway

Percent of map unit: 6 percent
Landform: Flats
Landform position (three-dimensional): Tread
Down-slope shape: Concave
Across-slope shape: Linear
Hydric soil rating: No

Collins

Percent of map unit: 4 percent
Landform: Flood-plain steps
Landform position (three-dimensional): Talf
Down-slope shape: Linear
Across-slope shape: Linear
Hydric soil rating: No

GrC3—Grenada silt loam, 6 to 12 percent slopes, severely eroded

Map Unit Setting

National map unit symbol: 1qls1
Elevation: 320 to 500 feet
Mean annual precipitation: 40 to 56 inches
Mean annual air temperature: 46 to 69 degrees F
Frost-free period: 177 to 222 days
Farmland classification: Not prime farmland

Map Unit Composition

Grenada, severely eroded, and similar soils: 85 percent
Minor components: 15 percent
Estimates are based on observations, descriptions, and transects of the mapunit.

Description of Grenada, Severely Eroded

Setting

Landform: Ridges
Landform position (two-dimensional): Backslope
Landform position (three-dimensional): Side slope
Down-slope shape: Convex
Across-slope shape: Linear
Parent material: Thick fine-silty noncalcareous loess

Typical profile

H1 - 0 to 4 inches: silt loam
H2 - 4 to 18 inches: silt loam
H3 - 18 to 22 inches: silt loam
H4 - 22 to 32 inches: silt loam
H5 - 32 to 80 inches: silt loam

Custom Soil Resource Report

Properties and qualities

Slope: 6 to 12 percent
Depth to restrictive feature: 18 to 23 inches to fragipan
Natural drainage class: Moderately well drained
Runoff class: High
Capacity of the most limiting layer to transmit water (Ksat): Moderately low to moderately high (0.06 to 0.20 in/hr)
Depth to water table: About 18 to 24 inches
Frequency of flooding: None
Frequency of ponding: None
Available water storage in profile: Low (about 4.9 inches)

Interpretive groups

Land capability classification (irrigated): None specified
Land capability classification (nonirrigated): 4e
Hydrologic Soil Group: D
Hydric soil rating: No

Minor Components

Purchase, severely eroded

Percent of map unit: 7 percent
Landform: Ridges
Landform position (two-dimensional): Backslope
Landform position (three-dimensional): Side slope
Down-slope shape: Convex
Across-slope shape: Linear
Hydric soil rating: No

Calloway

Percent of map unit: 4 percent
Landform: Ridges
Landform position (two-dimensional): Shoulder
Landform position (three-dimensional): Side slope
Down-slope shape: Convex
Across-slope shape: Linear
Hydric soil rating: No

Falaya

Percent of map unit: 2 percent
Landform: Drainageways
Down-slope shape: Linear
Across-slope shape: Linear
Hydric soil rating: No

Collins

Percent of map unit: 2 percent
Landform: Drainageways
Down-slope shape: Linear
Across-slope shape: Linear
Hydric soil rating: No



Alt & Witzig Engineering, Inc.

4105 West 99th Street • Indianapolis • Indiana • 46032
Ph (317) 875-7000 • Fax (317) 876-3705

August 30, 2018

GPD Group
8275 Allison Pointe Trail, Suite 220
Indianapolis, Indiana 46250
ATTN: Ms. Traci Preble

Resistivity Results

RE: EV Barlow – Cell Tower
2244 Steve Denton Road
Barlow, Kentucky
Alt & Witzig File: **18IN0510**

Dear Ms. Preble:

To aid in the design of the grounding equipment for the referenced project, soil resistivity tests were performed at the site. The resistivity testing was performed using an AEMC Model 6472 Soil Resistance Meter per ASTM G-57 (The Wenner Vertical Profiling Method). A qualified technician familiar with this equipment and testing procedure performed the appropriate test to obtain the resistivity values at multiple depths. Alt & Witzig Engineering, Inc. was able to gather the necessary resistivity information in all four (4) directions.

The Wenner Vertical Profiling Method was used by centering the potential electrodes on a traverse line between the current electrodes and maintaining an equal “a” spacing between the electrodes. The depths of interests or “a” spacing of 2½ feet, 5 feet, 12½ feet, 20 feet and 50 feet.

The resistivity test was performed on August 28, 2018. The weather during data collection was between 80 and 92 degrees and sunny. The measurements were taken in general vicinity of the proposed tower location and approximately one-hundred (100) feet south of Sallie Crice Road. The layouts of the arrays are shown below in *Exhibit 1*.

Offices:

Cincinnati • Columbus • Dayton, Ohio
Evansville • Ft. Wayne • Indianapolis • Lafayette • Merrillville/South Bend, Indiana

***Subsurface Investigation and Foundation Engineering
Construction Materials Testing and Inspection
Environmental Services***



Exhibit 1: Aerial Photograph of Site Showing the Layout of the Resistivity Array.



We appreciate the opportunity to be of service to you on this project. If we can give further service in these matters, please contact us at your convenience.

Very truly yours,
Alt & Witzig Engineering, Inc.

David M. Shumate
Geologist

David C. Harness, P.E.
Sr. Geotechnical Engineer

- Attachments:
- Boring Location Plan
 - Resistivity Testing Results

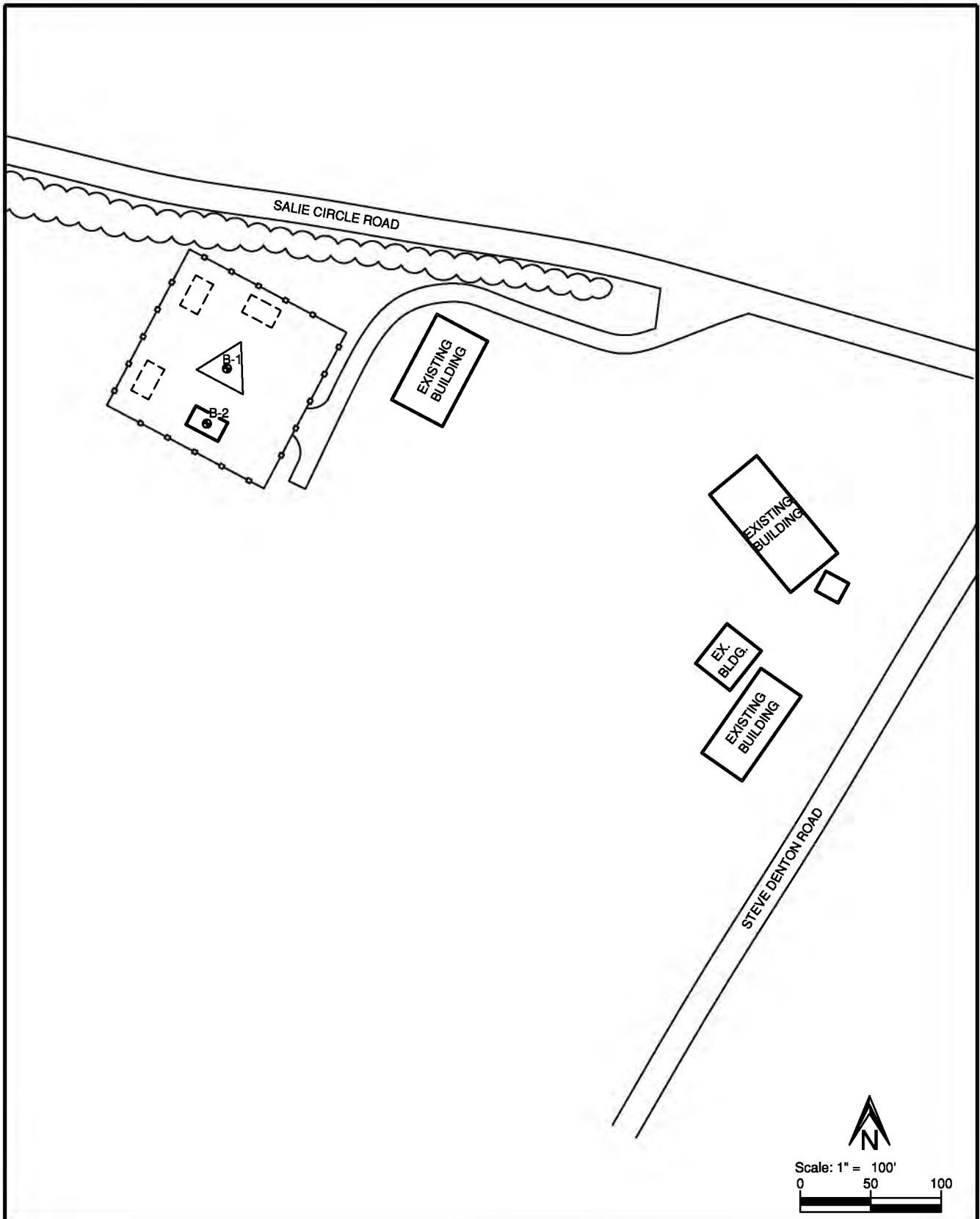

BORING LOCATION PLAN

PROJECT NAME: EV Barlow-Cell Tower
 LOCATION: 2244 Steve Denton Road
 PREPARED FOR: GPD Group
 PROJECT NO: 18IN0510

Project Manager: DS
 Checked By: DH
 Drawn By: JT
 Date: 08/18

AW Alt & Witzig Engineering, Inc.
 4105 West 99th Street • Carmel, IN 46032
 Telephone: (317) 875-7000 • Fax (317) 876-3705



Alt & Witzig Engineering, Inc
 4105 West 99th Street
 Carmel, IN 46032
 (317) 875-7000
 www.altwitzig.com

RESISTIVITY TESTING
WENNER 4-ELECTRODE METHOD
ASTM G57

A&W Project ID: 18IN0510

Site Location: EV Barlow

A&W Field Technician:	L. Folz	Engineer:	D. Harness
Weather Conditions	Sunny	Meter Used	AEMC 6472
Air Temperature:	80 - 92	Ground Condition:	Corn Field
Start Date	8/28/2018	Start Time	10:30am
End Date	8/28/2018	End Time	2:30pm

Where, ρ = resistivity in $\Omega \cdot cm$
 a = electrode separation, ft
 R = resistance, Ω

$$\rho, \Omega \cdot cm = 191.5 aR$$

Important notes:

- (1) large, nonconductive bodies shall not be included in the survey. Nonconductive bodies include: frozen soil, boulders, concrete foundations,
- (2) conductive structures such as pipes and cables shall not be within 1/2 a of the electrode span unless they are at right angles to the span.

Location	Spacing between electrodes, a (ft)	range switch	Dial Reading	Resistance, R ohms	Multiplier	Resistivity, ρ $\Omega \cdot cm$
NORTH	2.5	1	14.13	14.13	478.75	6,765
	5	1	6.818	6.818	957.5	6,528
	12.5	1	2.06	2.06	2393.75	4,931
	20	1	1.459	1.459	3830	5,588
	50	1	0.778	0.778	9575	7,449
SOUTH	2.5	1	9.242	9.242	478.75	4,425
	5	1	6.048	6.048	957.5	5,791
	12.5	1	2.196	2.196	2393.75	5,257
	20	1	1.466	1.466	3830	5,615
	50	1	0.828	0.828	9575	7,928
EAST	2.5	1	25.94	25.94	478.75	12,419
	5	1	7.36	7.36	957.5	7,047
	12.5	1	4.23	4.23	2393.75	10,126
	20	1	0.866	0.866	3830	3,317
	50	1	0.675	0.675	9575	6,463
WEST	2.5	1	55.44	55.44	478.75	26,542
	5	1	14.82	14.82	957.5	14,190
	12.5	1	2.311	2.311	2393.75	5,532
	20	1	1.355	1.355	3830	5,190
	50	1	1.064	1.064	9575	10,188

DIRECTIONS TO WFC SITE:

FROM BALLARD COUNTY SEAT; TAKE US-60 E TO N 6TH ST IN BARLOW (6.8 MI), HEAD NORTH ON 4TH ST TOWARD OHIO ST, PASS BY NAPA AUTO PARTS AUTO TIRE AND PARTS OF WICKCKLIFFE (ON THE RIGHT IN 0.2 MI)(0.5 MI), 4TH ST TURNS SLIGHTLY RIGHT AND BECOMES LEE ST (0.1 MI), CONTINUE ONTO US-60 E/N 6TH ST (CONTINUE TO FOLLOW US-60 E) (6.1 MI), TURN RIGHT ONTO BROADWAY ST (0.2 MI), TAKE KY-1105 N/OSCAR RD TO STEVE DENTON RD (5.3 MI), TURN LEFT AT THE 2ND CROSS STREET ONTO N 6TH ST (0.2 M), CONTINUE ONTO KY-1105 N/OSCAR RD (4.3 MI), TURN LEFT ONTO SALLIE CRICE RD (226 FT), TURN LEFT ONTO STEVE DENTON RD, ARRIVE AT DESTINATION 2244 STEVE DENTON RD.



PREPARED BY: GPD GROUP, INC. (317) 299-2996

utility is unable to use the aforementioned right-of-way, LESSOR has agreed to grant an additional right-of-way either to the LESSEE or to the public utility at no cost to the LESSEE.

3. The Commencement Date of the Agreement, of which this is a Memorandum, is the first day of the month after LESSEE begins installation of LESSEE'S communication equipment.
4. LESSEE has the right of first refusal to purchase the Premises during the initial term and all renewal terms of the Agreement.
5. The terms, covenants and provisions of the Agreement, the terms of which are hereby Incorporated by reference into this Memorandum, shall extend to and be binding upon the respective executors, administrators, heirs, successors and assigns of LESSOR and LESSEE.

IN WITNESS WHEREOF, hereunto and to a duplicate hereof, LESSOR and LESSEE have caused this Memorandum to be duly executed on the date first written hereinabove.

LESSOR:

THE MYATT FAMILY TRUST, DATED
SEPTEMBER 9, 2011, BY AND THROUGH
CHARLES MYATT AND DEENA MYATT,
TRUSTEES

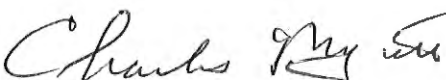
BY: 
Charles Myatt, Trustee

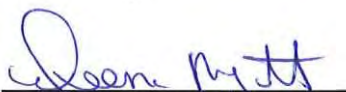
BY: 
Deena Myatt, Trustee

LESSEE:

KENTUCKY RSA 1 PARTNERSHIP D/B/A
VERIZON WIRELESS

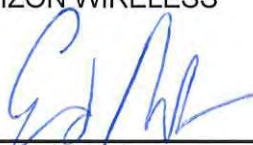
By: 
Name: Ed Maher
Title: Director Network Field Engineering

COMMONWEALTH OF KENTUCKY)
)
COUNTY OF BALLARD)

ACKNOWLEDGEMENT

I, Kreg D Denton, a Notary Public for said County and State, do hereby certify that Charles Myatt and Deena Myatt, personally came before me this day and acknowledged that they are the Trustees of The Myatt Family Trust, dated September 9, 2011, and being authorized to do so, executed the foregoing Memorandum of Land Lease Agreement as their own act and deed on behalf of The Myatt Family Trust, dated September 9, 2011.

WITNESS my hand and official Notarial Seal, this 16th day of October, 2018.

Kreg D. Denton
Notary Public

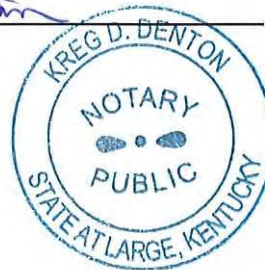

My Commission Expires:
7-17-2022

STATE OF MICHIGAN)
)
COUNTY OF OAKLAND)

ACKNOWLEDGMENT

I, Barbara Madigan Evans, a Notary Public for said County and State, do hereby certify that Ed Maher personally came before me this day and acknowledged that he is the Director Network Field Engineering for Kentucky RSA 1 Partnership d/b/a Verizon Wireless, and that he, as Director Network Field Engineering, being authorized to do so, executed the foregoing Memorandum of Land Lease Agreement on behalf of Kentucky RSA 1 Partnership d/b/a Verizon Wireless.

WITNESS my hand and official Notarial Seal, this 21st day of November, 2018.

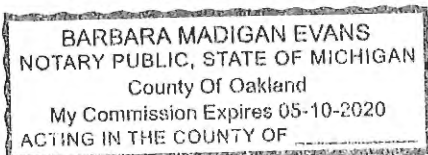

Barbara Madigan Evans
Notary Public

My Commission Expires:

"I affirm, under the penalties for perjury, that I have taken reasonable care to redact each Social Security number in this document, unless required by law." Matthew R. Clark

EXHIBIT A

[WRITTEN METES AND BOUNDS OF THE PREMISES
AND INGRESS/EGRESS AND UTILITY EASEMENT]

LEASE AREA DESCRIPTION

A PART OF A 69 ACRE PARCEL OF LAND OWNED BY THE MYATT FAMILY TRUST AS RECORDED IN DEED BOOK 112, PAGE 227, AND LYING SOUTHWEST OF THE INTERSECTION OF SALIE CIRCLE ROAD AND STEVE DENTON ROAD, BALLARD COUNTY, KENTUCKY.

COMMENCING AT AN IRON PIN FOUND AT THE INTERSECTION OF SAID SALIE CIRCLE ROAD AND STEVE DENTON ROAD, SAID POINT ALSO BEING THE NORTHEAST CORNER OF A PARCEL OF LAND OWNED BY DAVID L. JONES AS RECORDED IN DEED BOOK 93, PAGE 150, THENCE ALONG THE CENTERLINE OF SALIE CIRCLE ROAD NORTH 68 DEGREES 26 MINUTES 09 SECONDS WEST 172.37 FEET; THENCE SOUTH 71 DEGREES 49 MINUTES 20 SECONDS WEST 78.70 FEET; THENCE NORTH 76 DEGREES 06 MINUTES 17 SECONDS WEST 128.76 FEET; THENCE SOUTH 32 DEGREES 16 MINUTES 40 SECONDS WEST 132.35 FEET; THENCE NORTH 57 DEGREES 43 MINUTES 20 SECONDS WEST 30.00 FEET TO THE SOUTHERNMOST LEASE CORNER AND BEING THE TRUE PLACE OF BEGINNING OF THIS LEASE AREA DESCRIPTION; THENCE NORTH 57 DEGREES 43 MINUTES 20 SECONDS WEST 100.00 FEET; THENCE NORTH 32 DEGREES 16 MINUTES 40 SECONDS EAST 100.00 FEET; THENCE SOUTH 57 DEGREES 43 MINUTE 20 SECONDS EAST 100.00 FEET; THENCE SOUTH 32 DEGREES 16 MINUTES 40 SECONDS WEST 100.00 FEET TO THE TRUE PLACE OF BEGINNING AND CONTAINING 10,000 SQUARE FEET, (0.23 ACRES), MORE OR LESS.

30' ACCESS & UTILITY EASEMENT DESCRIPTION

A PART OF A 69 ACRE PARCEL OF LAND OWNED BY THE MYATT FAMILY TRUST AS RECORDED IN DEED BOOK 112, PAGE 227, AND LYING SOUTHWEST OF THE INTERSECTION OF SALIE CIRCLE ROAD AND STEVE DENTON ROAD, BALLARD COUNTY, KENTUCKY.

COMMENCING AT AN IRON PIN FOUND AT THE INTERSECTION OF SAID SALIE CIRCLE ROAD AND STEVE DENTON ROAD, SAID POINT ALSO BEING THE NORTHEAST CORNER OF A PARCEL OF LAND OWNED BY DAVID L. JONES AS RECORDED IN DEED BOOK 93, PAGE 150, THENCE ALONG THE CENTERLINE OF SALIE CIRCLE ROAD NORTH 68 DEGREES 26 MINUTES 09 SECONDS WEST 172.37 FEET TO THE TRUE PLACE OF BEGINNING OF THIS ACCESS AND EASEMENT DESCRIPTION; THENCE SOUTH 71 DEGREES 49 MINUTES 20 SECONDS WEST 78.70 FEET; THENCE NORTH 76 DEGREES 06 MINUTES 17 SECONDS WEST 128.76 FEET; THENCE SOUTH 32 DEGREES 16 MINUTES 40 SECONDS WEST 132.35 FEET; THENCE NORTH 57 DEGREES 43 MINUTES 20 SECONDS WEST 30.00 FEET TO THE SOUTHERNMOST LEASE CORNER; THENCE NORTH 32 DEGREES 16 MINUTES 40 SECONDS EAST 143.46 FEET; THENCE SOUTH 76 DEGREES 06 MINUTES 17 SECONDS EAST 141.78 FEET; THENCE NORTH 00 DEGREES 00 MINUTES 00 SECONDS EAST 23.37 FEET; THENCE SOUTH 68 DEGREES 26 MINUTES 09 SECONDS EAST 81.66 FEET TO THE TRUE PLACE OF BEGINNING AND CONTAINING 10,105.1 SQUARE FEET, (0.23 ACRES), MORE OR LESS.

STATE OF KENTUCKY
 RALPH M. WALLEM
 2195
 LICENSED PROFESSIONAL LAND SURVEYOR

LAND SURVEYOR'S CERTIFICATE

I HEREBY CERTIFY THAT THIS PLAT AND SURVEY WERE MADE UNDER MY SUPERVISION AND THAT THE ANGULAR AND LINEAR MEASUREMENTS AS WITNESSED BY MONUMENTS SHOWN HEREON ARE TRUE AND CORRECT TO THE BEST OF MY KNOWLEDGE AND BELIEF.

Ralph M. Wallem
 RALPH M. WALLEM

PLS NO. 80040185

NOTE: THIS DRAWING DOES NOT REPRESENT A BOUNDARY SURVEY.

verizon

TdeCAD
 Wireless

1961 NORTHPOINT BLVD.
 SUITE 130
 HIXSON, TN 37343

BENCHMARK
 SERVICES, INC.
 Consulting Engineers
 Land Surveyors
 316 North Main Street
 Huntington, TN 42422
 (615) 653-3046
 benchmark@bmv.tn.gov

PROJECT NUMBER:
 20161506655

SITE NAME:
 EV BARLOW

STATE ADDRESS:
 2557 STEVE DENTON RD
 BARLOW, KY 42024

LEASE AREA:
 10000 SQ. FT.

PROPERTY OWNER:
 MYATT FAMILY TRUST
 CHARLES MYATT & DEENA MYATT, TRUSTEES
 2244 STEVE DENTON ROAD
 BARLOW, KENTUCKY 42024

TAX PARCEL ID:
 24-30

COUNTY:
 BALLARD COUNTY

SOURCE OF TITLE:
 DEED BK 112, PG 227

LATITUDE: 37° 06' 42.145" N
 LONGITUDE: 89° 02' 44.583" W

DWG BY:	CHKD BY:	DATE:
GVW	RMW	12.22.17

NO.	REVISION/ISSUE	DATE:

TITLE:
 SURVEY PLAN

SHEET:
 2 OF 2

EXHIBIT "A"

EXHIBIT B

**[BOUNDARY SURVEY OF THE PREMISES
AND INGRESS/EGRESS AND UTILITY EASEMENT]**

deCAD

Wireless

1961 NORTHPOINT BLVD.
SUITE 130
HIXSON, TN 37343

BENCHMARK SERVICES, INC.

Consulting Engineers
Land Surveyors
250 South Main Street
Franklin, KY 40501
606.792.2600
www.benchmarksurvey.com

PROJECT NUMBER:
20161506655

SITE NAME:
EV BARLOW

SITE ADDRESS:
2557 STEVE DENTON RD
BARLOW, KY 42024

LEASE AREA:
10000 SQ. FT.

PROPERTY OWNER:
MYATT FAMILY TRUST
CHARLES MYATT & DEENA MYATT, TRUSTEES
2244 STEVE DENTON ROAD
BARLOW, KENTUCKY 42024

COUNTY:
BALLARD COUNTY

SOURCE OF TITLE:
DEED BK 112, PG 227

CHD BY: DATE:
RMW 12.22.17

TITLE:
SURVEY PLAN

SHEET:
1 OF 2

EXHIBIT "B"

△ CENTER OF TOWER
COORDINATE POINT LOCATION
NAD 1983
LATITUDE: 37° 06' 42.145" N
LONGITUDE: 89° 02' 44.583" W
NAVD 1988
SITE ELEVATION: 363.85 AMSL

POINT OF BEGINNING-ACCESS & UTILITY EASEMENT
POINT OF COMMENCEMENT-IRON
PIN FOUND IN ROAD INTERSECTION
AND BEING NORTHEASTERN CORNER
OF THE DAVID L. JONES PARCEL
AS RECORDED IN DEED BOOK 93,
PAGE 150, BALLARD COUNTY, KY

SCALE: 1"=60'
NORTH IS BASED ON KENTUCKY STATE PLANE
COORDINATE SYSTEM SOUTH ZONE AND WAS
DETERMINED BY COMPUTATION FROM G.P.S.
OBSERVATION ON DECEMBER 18, 2017

STATE OF KENTUCKY
RALPH M. WALLEM
2195
LICENSED PROFESSIONAL
LAND SURVEYOR

LAND SURVEYOR'S CERTIFICATE

I HEREBY CERTIFY THAT THIS PLAT AND SURVEY WERE MADE UNDER MY
SUPERVISION AND THAT THE ANGULAR AND LINEAR MEASUREMENTS AS
WITNESSED BY MONUMENTS SHOWN HEREON ARE TRUE AND CORRECT TO
THE BEST OF MY KNOWLEDGE AND BELIEF.

Ralph M. Wallem
RALPH M. WALLEM

PLS' NO. 80040185

NOTE: THIS DRAWING DOES NOT REPRESENT A BOUNDARY SURVEY.

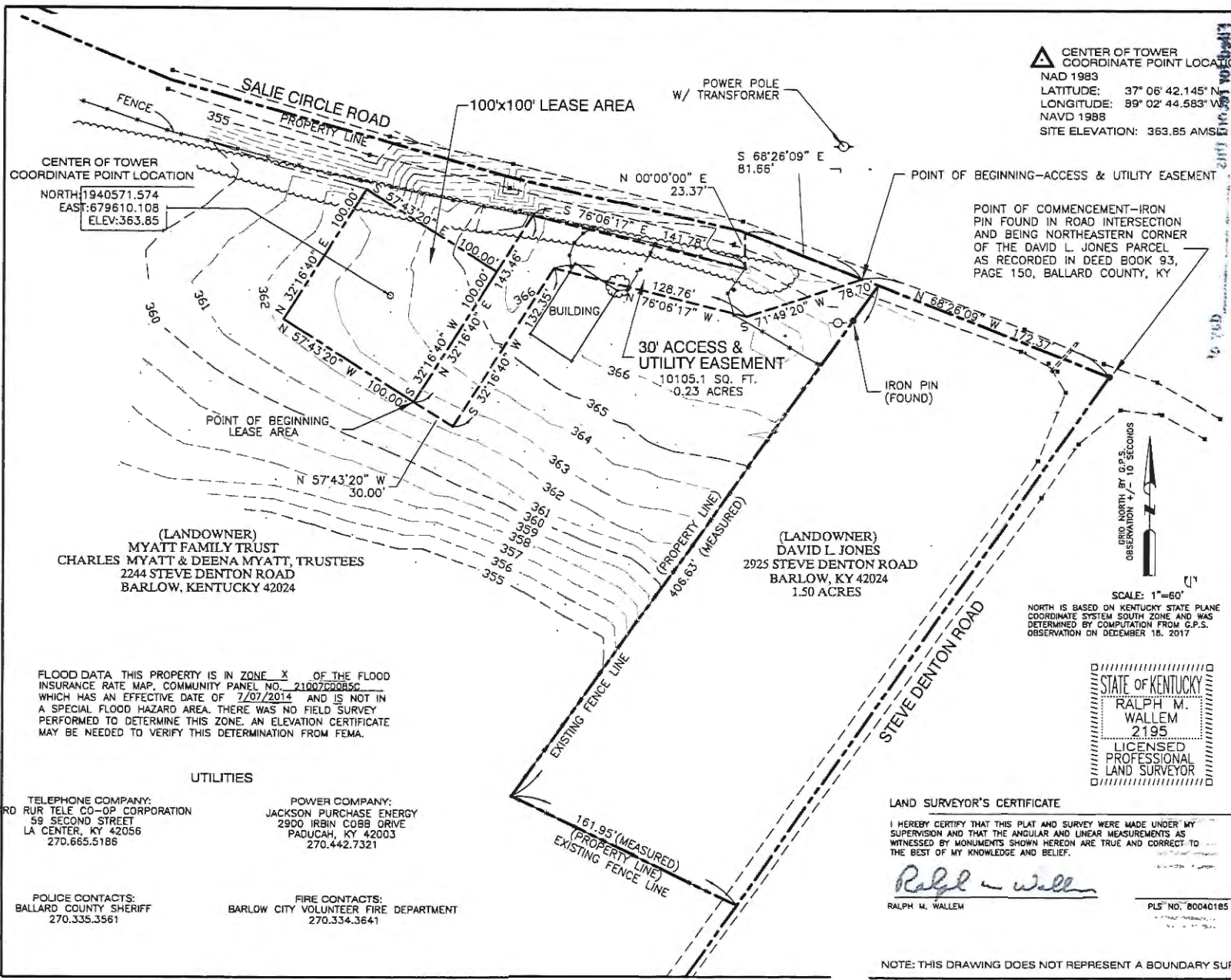

CENTER OF TOWER
COORDINATE POINT LOCATION
NORTH: 1940571.574
EAST: 679610.108
ELEV: 363.85

(LANDOWNER)
MYATT FAMILY TRUST
CHARLES MYATT & DEENA MYATT, TRUSTEES
2244 STEVE DENTON ROAD
BARLOW, KENTUCKY 42024

(LANDOWNER)
DAVID L. JONES
2925 STEVE DENTON ROAD
BARLOW, KY 42024
1.50 ACRES

FLOOD DATA THIS PROPERTY IS IN ZONE X OF THE FLOOD
INSURANCE RATE MAP, COMMUNITY PANEL NO. 21007C0085C
WHICH HAS AN EFFECTIVE DATE OF 7/07/2014 AND IS NOT IN
A SPECIAL FLOOD HAZARD AREA. THERE WAS NO FIELD SURVEY
PERFORMED TO DETERMINE THIS ZONE. AN ELEVATION CERTIFICATE
MAY BE NEEDED TO VERIFY THIS DETERMINATION FROM FEMA.

UTILITIES

TELEPHONE COMPANY:
BALLARD RUR TELE CO-OP CORPORATION
59 SECOND STREET
LA CENTER, KY 42056
270.665.5186

POWER COMPANY:
JACKSON PURCHASE ENERGY
2900 IRBIN COBB DRIVE
PADUCAH, KY 42003
270.442.7321

POLICE CONTACTS:
BALLARD COUNTY SHERIFF
270.335.3561

FIRE CONTACTS:
BARLOW CITY VOLUNTEER FIRE DEPARTMENT
270.334.3641

Filed for record this 3rd day of
Dec 2018, at 11:36 o'clock A m
recorded in Deed Book 118 page 287
LYNN W. LANE, Ballard County Clerk
By Katie S. Mercer
Fee \$ 29.00



265748
Filed on: 12/03/2018 12:02:56 PM
Book: DEED Number: 118
Pages: 287 - 293
Lynn Lane, Ballard County Clerk
DC: KATIE
Deed Tax: \$0.00

1/29

NOTICE LIST

1. Commonwealth of Kentucky
Dept. of Fish & Wildlife
Oscar Road
Highway 1105
La Center, KY 42056
2. Myatt Family Trust
Charles Myatt & Dee Ann Myatt, Trustees
2224 Steve Denton Road
Barlow, KY 42024
3. David L. Jones
2925 Steve Denton Road
Barlow, KY 42024
4. Flint Renfo
4540 Oscar Road
Barlow, KY 42024
5. Rhonda Rice & Coy Simmons
11930 Wallace Rd.
Kevil, KY 42053



February 2, 2022

Matthew R. Clark
Robert B. Scott
Charles R. Grahn
Frank D. Otte*
John "Bart" Herriman
William W. Gooden**
Michael P. Maxwell
Russell L. Brown**†
Jennifer F. Perry
Keith L. Beall
N. Davey Neal
Travis W. Cohron
Maggie L. Sadler
Kristin A. McIlwain
Olivia A. Hess

Land Use Consultant
Elizabeth Bentz Williams, AICP

**Notice of Proposed Construction of
Wireless Communications Facility
Site Name: Barlow**

Raymond J. Grahn (2015)
Alex M. Clark (1991)
Peter A. Pappas (1986)
Thomas M. Quinn (1973)
Joseph M. Howard (1964)

*Also admitted in Montana
†Also admitted in Kentucky
**Registered Civil Mediator

Cellco Partnership, d/b/a Verizon Wireless has filed an application with the Kentucky Public Service Commission ("PSC") to construct a new wireless communications facility on a site located at Steve Denton Road, Barlow, KY, 42024 (North Latitude: (37° 06' 42.15", West Longitude 89° 02' 44.58"). The proposed facility will include a 285-foot tall antenna tower, plus a 5-foot lightning arrestor, for a total height of 290 feet with related ground facilities. This facility is needed to provide improved coverage for wireless communications in the area.

This notice is being sent to you because the County Property Valuation Administrator's records indicate that you may own property that is within a 500' radius of the proposed tower site or contiguous to the property on which the tower is to be constructed. You have a right to submit testimony to the Kentucky Public Service Commission ("PSC"), either in writing or to request intervention in the PSC's proceedings on the application. You may contact the PSC for additional information concerning this matter at: Kentucky Public Service Commission, Executive Director, 211 Sower Boulevard, P.O. Box 615, Frankfort, Kentucky 40602. Please refer to docket number 2022-00016 in any correspondence sent in connection with this matter.

We have attached a map showing the site location for the proposed tower. Applicant's radio frequency engineers assisted in selecting the proposed site for the facility, and they have determined it is the proper location and elevation needed to provide quality service to wireless customers in the area. Please feel free to contact us at 317-637-1321 if you have any comments or questions about this proposal.

Sincerely,
Russell L. Brown

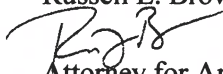
Attorney for Applicant
RLB/jdj
enclosure

VICINITY MAP

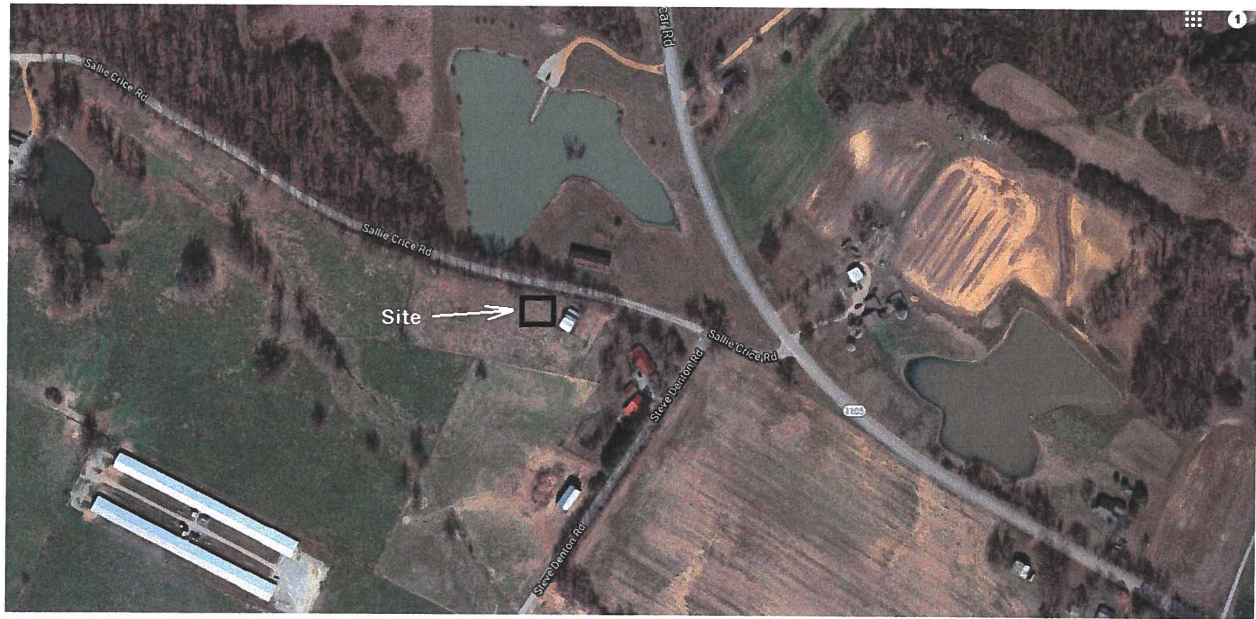
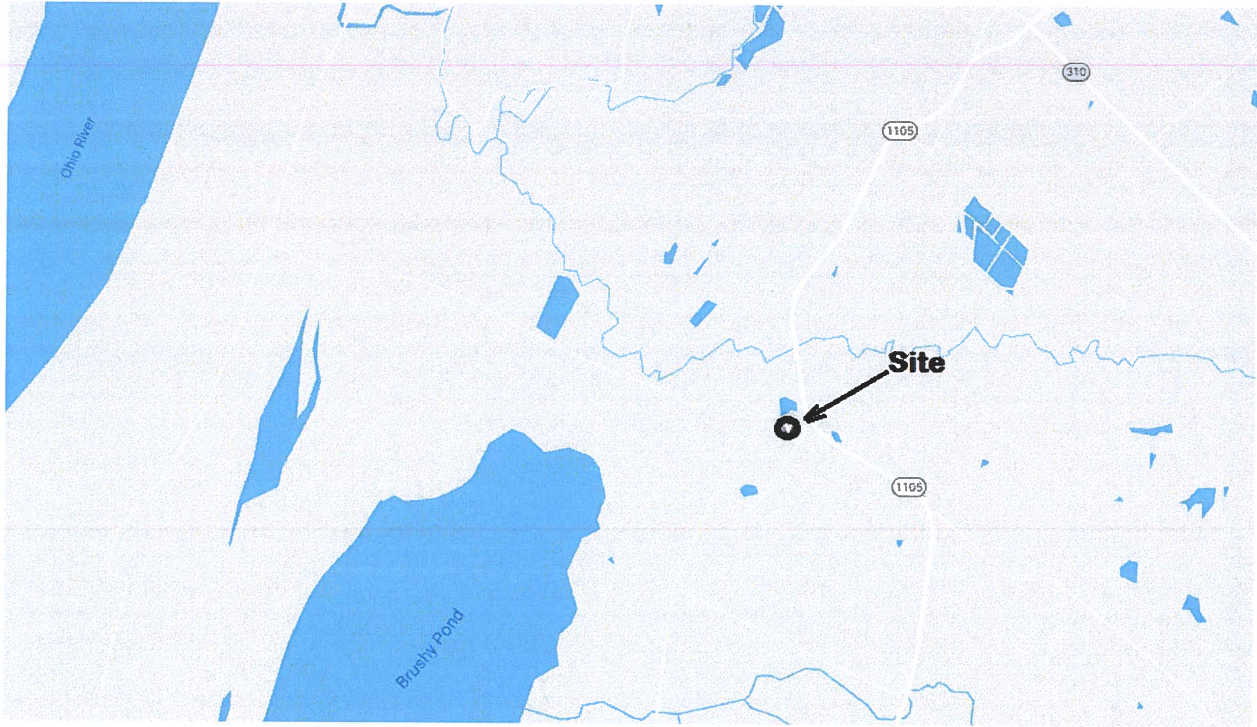

ClarkQuinn
Clark, Quinn, Moses, Scott & Grahn, LLP



FIRST-CLASS



US POSTAGE IMI PITNEY BOWES

ZIP 46204 \$ **007.33⁰**
02 7H
0006035028 FEB 02 2022

Commonwealth of Kentucky
Dept. of Fish & Wildlife
Oscar Road
Highway 1105
La Center, KY 42056



ClarkQuinn
Clark, Quinn, Moses, Scott & Grahn, LLP



FIRST-CLASS



US POSTAGE IMI PITNEY BOWES

ZIP 46204 \$ **007.33⁰**
02 7H
0006035028 FEB 02 2022

Myatt Family Trust
Charles Myatt & Dee Ann Myatt, Trustees
2224 Steve Denton Road
Barlow, KY 42024



ClarkQuinn
Clark, Quinn, Moses, Scott & Grahn, LLP



FIRST-CLASS



US POSTAGE IMI PITNEY BOWES

ZIP 46204 \$ **007.33⁰**
02 7H
0006035028 FEB 02 2022

David L. Jones
2925 Steve Denton Road
Barlow, KY 42024

CERTIFIED MAIL[®]

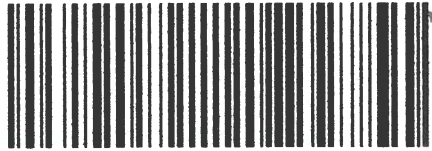
ClarkQuinn
Clark, Quinn, Moses, Scott & Grahn, LLP



7020 1810 0002 1853 5010

FIRST-CLASS



US POSTAGE[™] IMI PITNEY BOWES



ZIP 46204 \$ 007.33⁰
02 7H
0006035028 FEB 02 2022

Flint Renfo
4540 Oscar Road
Barlow, KY 42024

CERTIFIED MAIL[®]

ClarkQuinn
Clark, Quinn, Moses, Scott & Grahn, LLP

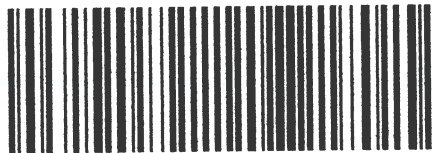

7020 1810 0002 1853 0039

FIRST-CLASS



US POSTAGE[™] IMI PITNEY BOWES



ZIP 46204 \$ 007.33⁰
02 7H
0006035028 FEB 02 2022

Rhonda Rice & Coy Simmons
11930 Wallace Road
Kevil, KY 42053

7020 1810 0002 1853 0039

U.S. Postal Service™
CERTIFIED MAIL® RECEIPT
Domestic Mail Only

For delivery information, visit our website at www.usps.com®.

OFFICIAL USE

Certified Mail Fee \$	Postmark Here
Extra Services & Fees (check box, add fee as appropriate)	
<input type="checkbox"/> Return Receipt (hardcopy) \$	
<input type="checkbox"/> Return Receipt (electronic) \$	
<input type="checkbox"/> Certified Mail Restricted Delivery \$	
<input type="checkbox"/> Adult Signature Required \$	
<input type="checkbox"/> Adult Sign	
Postage \$	
Total Posta \$	
Sent To	
Street and /	
City, State, ZIP+4®	

Rhonda Rice & Coy Simmons
 11930 Wallace Road
 Kevil, KY 42053

PS Form 3800, April 2015 PSN 7530-02-000-9047 See Reverse for Instructions

7020 1810 0002 1853 0041

U.S. Postal Service™
CERTIFIED MAIL® RECEIPT
Domestic Mail Only

For delivery information, visit our website at www.usps.com®.

OFFICIAL USE

Certified Mail Fee \$	Postmark Here
Extra Services & Fees (check box, add fee as appropriate)	
<input type="checkbox"/> Return Receipt (hardcopy) \$	
<input type="checkbox"/> Return Receipt (electronic) \$	
<input type="checkbox"/> Certified Mail Restricted Delivery \$	
<input type="checkbox"/> Adult Signature Required \$	
<input type="checkbox"/> Adult Sign	
Postage \$	
Total Posta \$	
Sent To	
Street and A	
City, State, ZIP+4®	

Myatt Family Trust
 Charles Myatt &
 Dee Ann Myatt, Trustees
 2224 Steve Denton Road
 Barlow, KY 42024

PS Form 3800, April 2015 PSN 7530-02-000-9047 See Reverse for Instructions

7020 1810 0002 1853 5027

U.S. Postal Service™
CERTIFIED MAIL® RECEIPT
Domestic Mail Only

For delivery information, visit our website at www.usps.com®.

OFFICIAL USE

Certified Mail Fee \$	Postmark Here
Extra Services & Fees (check box, add fee as appropriate)	
<input type="checkbox"/> Return Receipt (hardcopy) \$	
<input type="checkbox"/> Return Receipt (electronic) \$	
<input type="checkbox"/> Certified Mail Restricted Delivery \$	
<input type="checkbox"/> Adult Signature Required \$	
<input type="checkbox"/> Adult Sign	
Postage \$	
Total P \$	
Sent To	
Street	
City, State, ZIP+4®	

David L. Jones
 2925 Steve Denton Road
 Barlow, KY 42024

PS Form 3800, April 2015 PSN 7530-02-000-9047 See Reverse for Instructions

7020 1810 0002 1853 5010

U.S. Postal Service™
CERTIFIED MAIL® RECEIPT
Domestic Mail Only

For delivery information, visit our website at www.usps.com®.

OFFICIAL USE

Certified Mail Fee \$	Postmark Here
Extra Services & Fees (check box, add fee as appropriate)	
<input type="checkbox"/> Return Receipt (hardcopy) \$	
<input type="checkbox"/> Return Receipt (electronic) \$	
<input type="checkbox"/> Certified Mail Restricted Delivery \$	
<input type="checkbox"/> Adult Signature Required \$	
<input type="checkbox"/> Ad	
Postage \$	
Total \$	
Sent To	
Street	
City, State, ZIP+4®	

Flint Renfo
 4540 Oscar Road
 Barlow, KY 42024

PS Form 3800, April 2015 PSN 7530-02-000-9047 See Reverse for Instructions

7020 1810 0002 1853 5034

U.S. Postal Service™
CERTIFIED MAIL® RECEIPT
Domestic Mail Only

For delivery information, visit our website at www.usps.com®.

OFFICIAL USE

Certified Mail Fee \$	Postmark Here
Extra Services & Fees (check box, add fee as appropriate)	
<input type="checkbox"/> Return Receipt (hardcopy) \$	
<input type="checkbox"/> Return Receipt (electronic) \$	
<input type="checkbox"/> Certified Mail Restricted Delivery \$	
<input type="checkbox"/> Adult Signature Required \$	
<input type="checkbox"/> Adult S	
Postage \$	
Total Pos \$	
Sent To	
Street and	
City, State, ZIP+4®	

Commonwealth of Kentucky
 Dept. of Fish & Wildlife
 Oscar Road
 Highway 1105
 La Center, KY 42056

PS Form 3800, April 2015 PSN 7530-02-000-9047 See Reverse for Instructions



ClarkQuinn
Clark, Quinn, Moses, Scott & Grahn, LLP

February 2, 2022

VIA CERTIFIED MAIL
7020 1810 0002 1853 0596

Hon. Todd Cooper
437 Ohio Street
Wickliffe, KY 402087

RE: Notice of Proposal to Construct Wireless Communications Facility
Kentucky Public Service Commission Docket No. 2022- 00016
Site Name: Barlow

Dear Judge Cooper:

Cellco Partnership, d/b/a Verizon Wireless has filed an application with the Kentucky Public Service Commission ("PSC") to construct a new wireless communications facility on a site located at Steve Denton Road, Barlow, KY, 42024 (North Latitude: (37° 06' 42.15", West Longitude 89° 02' 44.58"). The proposed facility will include a 285-foot tall antenna tower, plus a 5-foot lightning arrester, for a total height of 290 feet with related ground facilities. This facility is needed to provide improved coverage for wireless communications in the area.

You have a right to submit comments to the PSC or to request intervention in the PSC's proceedings on the application. You may contact the PSC at: Executive Director, Public Service Commission, 211 Sower Boulevard, P.O. Box 615, Frankfort, Kentucky 40602. Please refer to docket number 2022-00016 in any correspondence sent in connection with this matter.

We have attached a map showing the site location for the proposed tower. Verizon Wireless' radio frequency engineers assisted in selecting the proposed site for the facility, and they have determined it is the proper location and elevation needed to provide quality service to wireless customers in the area. Please feel free to contact us with any comments or questions you may have.

Sincerely,

Russell L. Brown

Attorney for Applicants

RLB/jdj
enclosure

Matthew R. Clark
Robert B. Scott
Charles R. Grahn
Frank D. Otte*
John "Bart" Herriman
William W. Gooden**
Michael P. Maxwell
Russell L. Brown**†
Jennifer F. Perry
Keith L. Beall
N. Davey Neal
Travis W. Cohron
Maggie L. Sadler
Kristin A. McIlwain
Olivia A. Hess

Land Use Consultant
Elizabeth Bentz Williams, AICP

Raymond J. Grahn (2015)
Alex M. Clark (1991)
Peter A. Pappas (1986)
Thomas M. Quinn (1973)
Joseph M. Howard (1964)

*Also admitted in Montana
†Also admitted in Kentucky
**Registered Civil Mediator

VICINITY MAP

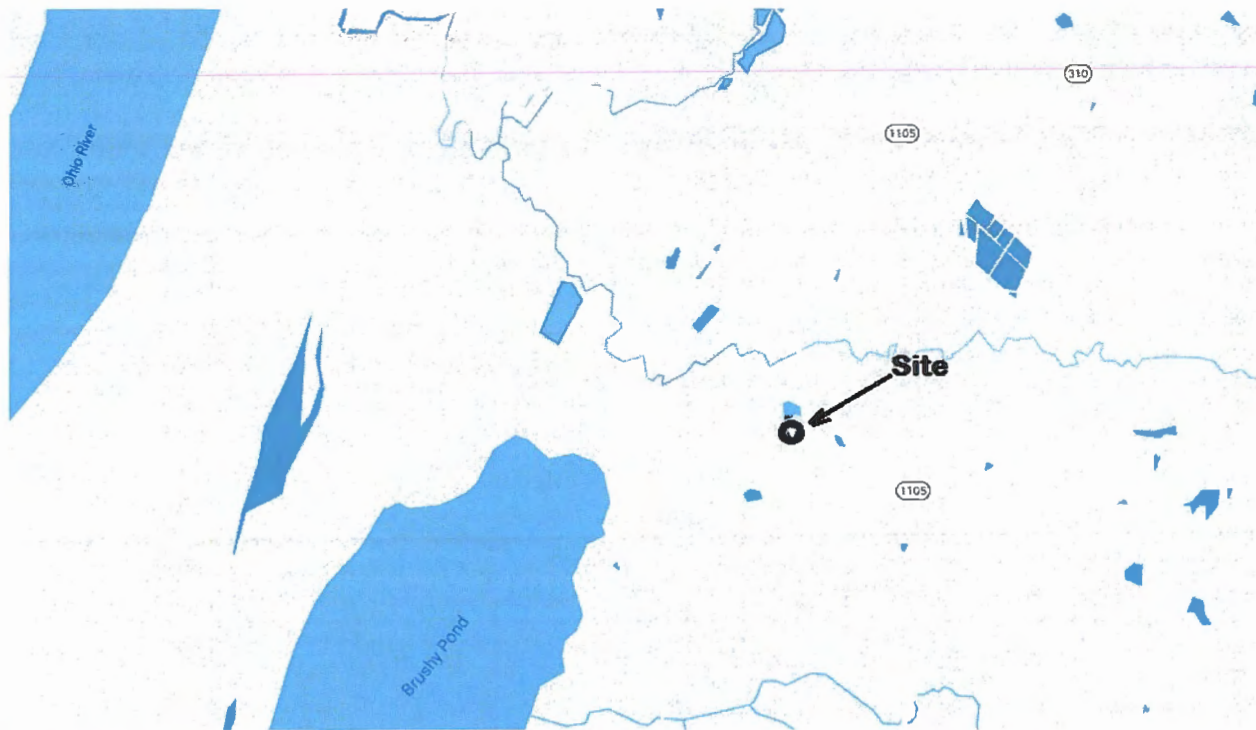



ClarkQuinn
Clark, Quinn, Moses, Scott & Grahn, LLP

February 2, 2022

Matthew R. Clark
Robert B. Scott
Charles R. Grahn
Frank D. Otte*
John "Bart" Herriman
William W. Gooden**
Michael P. Maxwell
Russell L. Brown**†
Jennifer F. Perry
Keith L. Beall
N. Davey Neal
Travis W. Cohron
Maggie L. Sadler
Kristin A. McIlwain
Olivia A. Hess

Land Use Consultant
Elizabeth Bentz Williams, AICP

**Notice of Proposed Construction of
Wireless Communications Facility
Site Name: Barlow**

Raymond J. Grahn (2015)
Alex M. Clark (1991)
Peter A. Pappas (1986)
Thomas M. Quinn (1973)
Joseph M. Howard (1964)

*Also admitted in Montana
†Also admitted in Kentucky
**Registered Civil Mediator

Cellco Partnership, d/b/a Verizon Wireless has filed an application with the Kentucky Public Service Commission ("PSC") to construct a new wireless communications facility on a site located at Steve Denton Road, Barlow, KY, 42024 (North Latitude: (37° 06' 42.15", West Longitude 89° 02' 44.58"). The proposed facility will include a 285-foot tall antenna tower, plus a 5-foot lightning arrestor, for a total height of 290 feet with related ground facilities. This facility is needed to provide improved coverage for wireless communications in the area.

This notice is being sent to you because the County Property Valuation Administrator's records indicate that you may own property that is within a 500' radius of the proposed tower site or contiguous to the property on which the tower is to be constructed. You have a right to submit testimony to the Kentucky Public Service Commission ("PSC"), either in writing or to request intervention in the PSC's proceedings on the application. You may contact the PSC for additional information concerning this matter at: Kentucky Public Service Commission, Executive Director, 211 Sower Boulevard, P.O. Box 615, Frankfort, Kentucky 40602. Please refer to docket number 2022-00016 in any correspondence sent in connection with this matter.

We have attached a map showing the site location for the proposed tower. Applicant's radio frequency engineers assisted in selecting the proposed site for the facility, and they have determined it is the proper location and elevation needed to provide quality service to wireless customers in the area. Please feel free to contact us at 317-637-1321 if you have any comments or questions about this proposal.

Sincerely,
Russell L. Brown

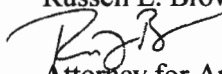
Attorney for Applicant
RLB/jdj
enclosure

VICINITY MAP

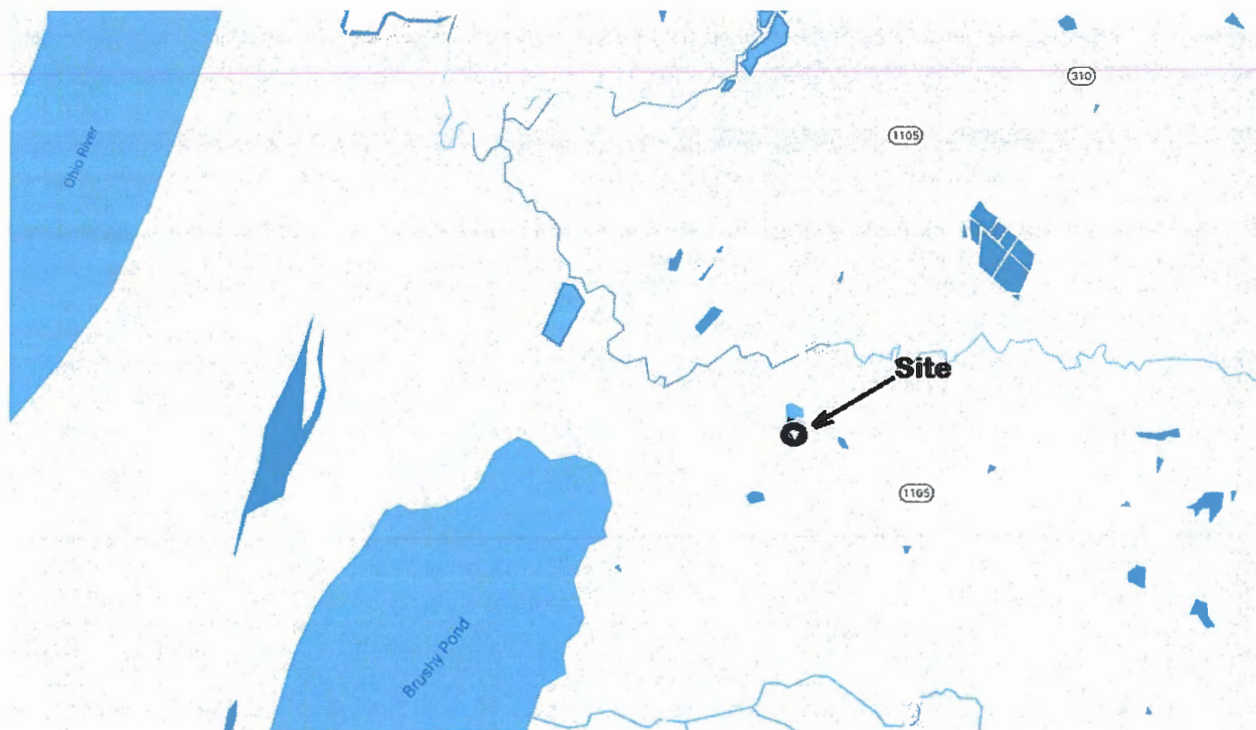

SITE NAME: Barlow NOTICE SIGNS

The signs are at least (2) feet by four (4) feet in size, of durable material, with the text printed in black letters at least one (1) inch in height against a white background, except for the word "**tower**," which is at least four (4) inches in height.

Cellco Partnership, d/b/a Verizon Wireless propose to construct a telecommunications **tower** on this site. If you have questions, please contact Clark, Quinn, Moses, Scott & Grahn, LLP, 320 N. Meridian Street, Indianapolis, IN 46204; 317-637-1321, or the Executive Director, Public Service Commission, 211 Sower Boulevard, PO Box 615, Frankfort, Kentucky 40602. Please refer to docket number 2022-00016 in your correspondence.

Cellco Partnership, d/b/a Verizon Wireless propose to construct a telecommunications **tower** on this site. If you have questions, please contact Clark, Quinn, Moses, Scott & Grahn, LLP, 320 N. Meridian Street, Indianapolis, IN 46204; 317-637-1321, or the Executive Director, Public Service Commission, 211 Sower Boulevard, PO Box 615, Frankfort, Kentucky 40602. Please refer to docket number 2022-00016 in your correspondence.

VIA EMAIL: larrah@ky-news.com
advanceyeoman@gmail.com

Kentucky Publishing Inc.
1540 McCracken Blvd.
Paducah, KY 42001

February 1, 2022

RE: Legal Notice Advertisement
Site Name: Barlow

Dear Ms. Workman:

Please publish the following legal notice advertisement in the next available edition of the *Advance Yeoman*:

NOTICE

Cellco Partnership, d/b/a Verizon Wireless has filed an application with the Kentucky Public Service Commission ("PSC") to construct a new wireless communications facility on a site located at Steve Denton Road, Barlow, KY, 42024 (North Latitude: (37° 06' 42.15", West Longitude 89° 02' 44.58"). You may contact the PSC for additional information concerning this matter at: Kentucky Public Service Commission, Executive Director, 211 Sower Boulevard, P.O. Box 615, Frankfort, Kentucky 40602. Please refer to docket number 2022-00016 in any correspondence sent in connection with this matter.

After this advertisement has been published, please forward a tearsheet copy, affidavit of publication, and invoice to Clark, Quinn, Moses, Scott & Grahn, LLC, 320 N. Meridian Street, Indianapolis, IN 46204 or by email to ebw@clarkquinnlaw.com. Please call me or Elizabeth Bentz Williams, in our offices at (317) 637-1321 if you have any questions. Thank you for your assistance.

Sincerely

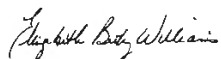

Elizabeth Bentz Williams
Clark, Quinn, Moses, Scott & Grahn, LLC

Radio Frequency Design Search Area





Wednesday, December 5, 2018

RE: Proposed Verizon Wireless Communications Facility

Site Name: **EV Barlow.**

Type of Tower: 280' self-support Tower.

Location: 2557 Steve Denton Rd Barlow, KY 42024.

To Whom It May Concern:

As a radio frequency engineer for Verizon Wireless, I am providing this letter to state the need for a Verizon Wireless site called **EV Barlow.**

The **EV Barlow** site is proposed with the below objectives:

1. Offload 4G traffic from busy site to the northwest.
2. Offload 4G traffic from busy site to the northeast.
3. Improve 4G throughput to existing heavy data users.
4. Improve 4G network reliability by increasing the amount of time our customers operate on 4G instead of 3G.

Currently the area is experiencing high demand for wireless high-speed data. Growth forecasts have triggered the need for an additional site in the area. The tower is needed to provide all Verizon customers in the area with the best experience on their 4G wireless devices.

Raw Land – Design plans for a new tower would provide tower height of **280'**. The new structure height was decided upon to best cover the offload area and interact with the existing Verizon sites. If we are limited to building a structure less than the proposed height, another tower would be needed in the vicinity in the near future. In addition, building a structure that is too short can cause existing taller sites to shoot over the proposed site and building a site that is too tall can cause the proposed site to shoot over existing sites. Both situations create a poor experience from a user perspective. The new structure will be placed near the center of the area with high traffic demand and offload the surrounding sites greatly. The new tower design meets stated objectives.

Verizon Wireless cares about the communities as well as the environment and prefers to collocate on existing structures when available. It can be noticed from any map that Verizon Wireless is currently collocated on many existing structures in the area. We prefer collocation due to reduced construction costs, faster deployment, and environment protection. However, Verizon Wireless was unable to find a suitable structure within the center of demand area to collocate the proposed **EV Barlow** site.



Verizon Wireless design engineers establish search area criteria in order to effectively meet coverage objectives as well as offload existing Verizon cell sites. When met, the criterion also reduces the need for a new site to cover the area in the immediate future. Each cellular site covers a limited area, depending on site configuration and the surrounding terrain. Cell sites are built in an interconnected network; which means each cell site must be located so that their respective coverage areas are contiguous. This provides uninterrupted communications throughout the coverage area.

Since collocation is generally the most cost-effective means for prompt deployment of new facilities, Verizon Wireless makes every effort to investigate the feasibility for using existing towers or other tall structures for collocation when designing a new site or system expansion. However, collocation on an existing tower or tall structure is not always feasible due to location of existing cell sites. Cell sites are placed in a way so they provide smooth hand off to each other and are placed at some distance from each other to eliminate too much overlap. Too much overlap may result in a waste of resources and raise a system capacity overload concern.

This cell site has been designed, and shall be constructed and operated in a manner that satisfies regulations and requirements of all applicable governmental agencies that have been charged with regulating tower specifications, operation, construction, and placement, including the FAA and FCC.

Sincerely,

Michael Fahim.

RF Engineer, Verizon Wireless

A handwritten signature in blue ink that reads "Michael Fahim". The signature is written in a cursive style and is positioned below the typed name.



STATE OF INDIANA

COUNTY OF HAMILTON

Subscribed and sworn to before me this 5th day of DECEMBER, 2018.

Notary Public

Signature *Thomas D Herndon*

THOMAS D. HERNDON
Notary Public, State of Indiana
SEAL
My Commission Expires 9/2/2023

Printed THOMAS D. HERNDON

County of Residence HAMILTON

My Commission expires:

9-2-2023



Wednesday, December 5, 2018

RE: Ballard County Zoning Plots

Site Name: **EV Barlow.**

To Whom It May Concern:

This map is not a guarantee of coverage and may contain areas with no service. This map reflects a depiction of predicted and approximate wireless coverage of the network and is intended to provide a relative comparison of coverage. The depictions of coverage do not guarantee service availability as there are many factors that can influence coverage and service availability. These factors vary from location to location and change over time. The coverage areas may include locations with limited or no coverage. Even within a coverage area shown, there are many factors, including but not limited to, usage volumes, service, outage, and customer's equipment, and terrain, proximity to buildings, foliage, and weather that may impact service.

The proposed site is needed to offload capacity from existing sites. This map reflects the predicted coverage area that will be offloaded from existing sites and transferred to the proposed site.

Michael Fahim.

RF Engineer, Verizon Wireless

EV Barlow Pre

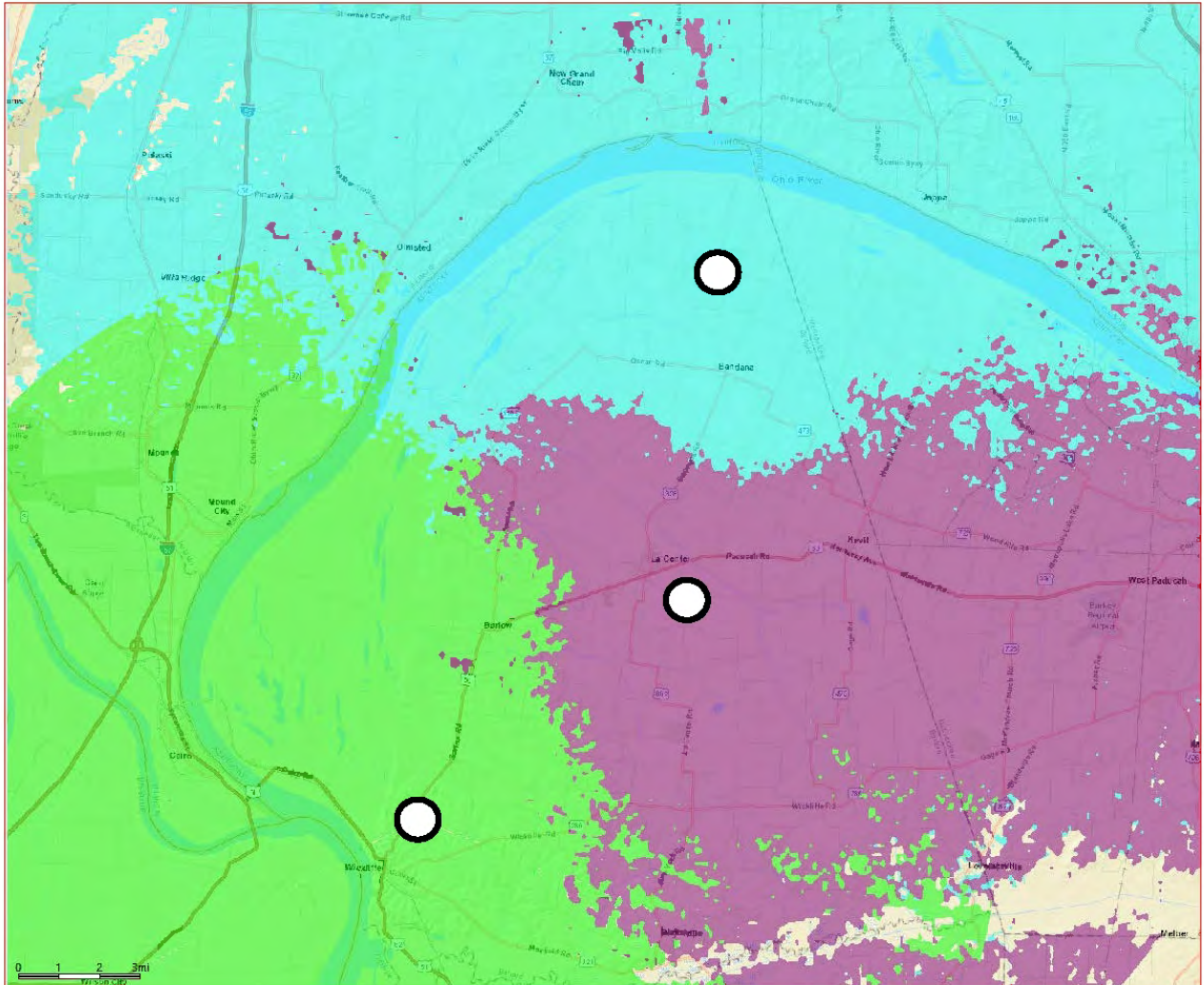

Legend:

Existing Verizon Sites	○
Proposed Verizon Site	●
Future Verizon Site	○
County Border	-----

EV Barlow Post

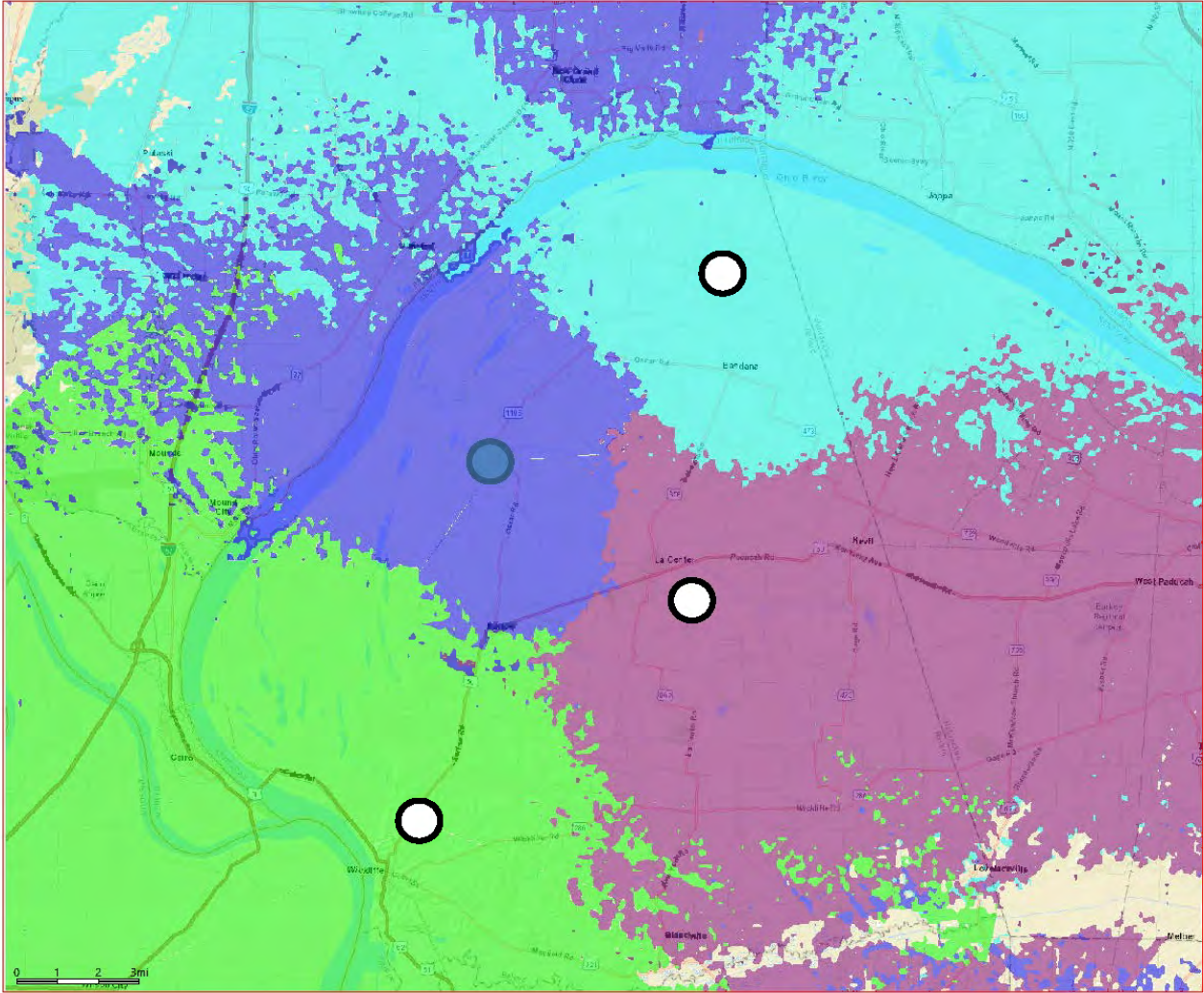

Legend:

Existing Verizon Sites	○
Proposed Verizon Site	●
Future Verizon Site	○
County Border	-----

Exhibit R
List and Identity and Qualifications of Professionals

Ralph M. Wallem
Professional Land Surveyor
Kentucky License 2195
Benchmark Services, Inc.
318 North Main Street, PO Box 5
Huntingburg, IN 47542

Leonardo A. Sfera
Professional Civil Engineer
Kentucky License 31562
GPD Group, Incorporated
520 South Main Street, Suite 2531
Akron, OH 44311

Christopher J. Scheks
Professional Structural Engineer
Kentucky License 29760
GPD Group, Incorporated
520 South Main Street, Suite
2531 Akron, OH 44311

Stephen P. Schaub
Professional Electrical Engineer
Kentucky License 29006
GPD Group, Incorporated
520 South Main Street, Suite
2531 Akron, OH 44311

Robert E. Beacom
Professional Engineer
Kentucky License 28165
Saber Communications Corporation
7101 Southbridge Drive, PO Box 658
Sioux City, IA 51102 - 0658

Vince Caprino
Construction Manager
Verizon Wireless

2421 Holloway Road
Louisville, KY 40299

Michael Fahim
RF Engineer
Verizon Wireless
2421 Holloway Road
Louisville, KY 40299

David M. Shumate
Staff Geologist
Davis C. Harness
Professional Electrical Engineer
Kentucky License 20569
Alt & Witzig Engineering, Inc.
4105 West 99th Street
Indianapolis, IN 46032

Electrical
Tom Dilworth
Jackson Purchase Energy
2900 Urban Cobb Toad
Paducah, KY 42002

