

COMMONWEALTH OF KENTUCKY
BEFORE THE KENTUCKY STATE BOARD ON
ELECTRIC GENERATION AND TRANSMISSION SITING

In the Matter of:

ELECTRONIC APPLICATION OF)	
STONEFIELD SOLAR, LLC FOR A)	
CERTIFICATE OF CONSTRUCTION FOR)	
AN APPROXIMATELY 120 MEGAWATT)	Case No. 2022-00011
MERCHANT ELECTRIC SOLAR GENERATING)	
FACILITY AND NONREGULATED)	
TRANSMISSION LINE IN HARDIN COUNTY,)	
KENTUCKY PURSUANT TO KRS 278.700)	
ET SEQ. AND 807 KAR 5:110.)	

Application for Certificate of Construction

Stonefield Solar, LLC (“the Applicant” or “Stonefield Solar”), files this application requesting from the Kentucky State Board on Electric Generation and Transmission Siting (“the Board”) certificates of construction for an approximately 120 megawatt (MW) merchant electric solar generating facility and a nonregulated electric transmission line pursuant to KRS 278.704 and 278.714 (the “Application”). The generating facility and nonregulated transmission line for which the certificates are sought will be located in Hardin County, Kentucky.

In support of this Application and for ease of review, the Applicant submits herewith the Table of Contents required by 807 KAR 5:110 §3(2)(b) and a Crosswalk of Regulatory Requirements. The Crosswalk lists the legal requirements for a merchant electric generating facility application and a nonregulated electric transmission line application, and the principal place(s) each requirement is addressed in these Application materials. The facts on which the Application is based are contained in the concurrently filed exhibits, reports, and the statements further made by the Applicant, as follows:

I. Applicant Information

1. Pursuant to KRS 278.706(2)(a) and 278.714(2)(a), the name, address, and telephone number of the person proposing to construct and own the merchant electric generating facility and nonregulated electric transmission line is as follows: Stonefield Solar, LLC; 500 Sansome St, Suite 500, San Francisco, CA, 94111. The applicant's telephone number is: (270) 681-5720 and its email address is: info@stonefieldsolar.com. Communications should be directed to the attention of Rick Ferrera.

II. Description of Proposed Site

2. The proposed Stonefield Solar Project (“the Project”) is a 120 MW solar facility capable of providing enough clean, renewable electricity to power approximately 24,000 Kentucky homes. Photovoltaic (PV) solar modules are used to convert sunlight into direct current (DC) electricity which is then converted to alternating current (AC) electricity through inverters. Transformers step up AC electricity to a higher voltage so that it can connect to the regional transmission grid.

3. Pursuant to KRS 278.706(2)(b), The Project is located on 1,030 acres of unincorporated property near Elizabethtown, Kentucky in Hardin County (Exhibit A). The Project footprint, generally the area within the fence line where Project infrastructure will be located, includes 817 acres. The site consists of eight parcels leased from three landowners and one parcel with an option to be purchased by the Applicant (see Exhibit A). All parcels are currently zoned Rural Residential Zone (R-2), which is the default zoning for Hardin County, and currently are used primarily for agricultural purposes. The properties include primarily row crops and vegetation is sparse aside from forested riparian areas generally associated with West Rhudes Creek and the

ephemeral and intermittent streams that cross the properties. Many of the delineated onsite waters (streams and wetlands) do not fall under the jurisdiction of the U.S. Army Corps of Engineers because they lack surface water connections to jurisdictional features. Additionally, the site is situated in an area known for karst geology, including sinkholes. The generation site parcels will likely be rezoned to Heavy Industrial (I-2) prior to commencing construction. The Project is adjacent to a Vulcan Materials Company construction aggregates quarry and generally fits within the I-2 category.

4. Pursuant to KRS 278.714(2)(b) the nonregulated electric transmission line will start at approximate coordinates 37°38'29.94" N 85°56'38.48" W and run north to east approximately 13,523 feet to the existing Central Hardin 138kV substation, owned and operated by Eastern Kentucky Power Cooperative (EKPC), a Touchstone Energy Cooperative located on Pritchard Parkway in Elizabethtown. The proposed voltage of the nonregulated electric transmission line is 69 kV and maintained within a proposed 50-foot right-of-way. The proposed right-of-way will be within a number of parcels (Exhibit A-1). The nonregulated electric transmission line will be approximately 159 feet from the nearest non-participating residential structure and there are no participating structures near the proposed route. One school and one public or private park exist within one mile of the proposed nonregulated electric transmission line as shown in Exhibit A-2. The proposed nonregulated electric transmission line will not exist within 1,000 feet of a residential neighborhood, school, or park.

5. Approximately 50,000 linear feet of private access roads will be utilized within the facility and will be constructed of all-weather gravel. The array access roads will not exceed 12 feet in width, except for turning radii, which will not exceed 40 feet in radius. Two-foot shoulders will be constructed on all access roads. The substation access road will not exceed 20 feet in width.

The Project solar arrays will be secured with approximately 68,800 linear feet of perimeter agricultural fence which will consist of wood posts and fixed-knot woven wire, and will not exceed seven feet in height. Fixed lighting at the perimeter will be limited to gates and the substation area, will be down-lit, and motion-activated to minimize light spillage. The Project will utilize construction methods that minimize large-scale grading and removal of native soil. Clearing and grubbing will occur where necessary. Grading may be required to level rough or undulating areas of the site and to prepare soils for concrete foundations, substation equipment, and inverters. Access roads will also be grubbed, graded, and compacted. The site cut and fill will be appropriately balanced, with no anticipation of import/export necessary.

6. Project components will include PV solar modules mounted on single axis tracker systems supported by steel posts. Panels will move to track the sun over the course of the day. Other components of the PV system include combiner boxes, inverters, high voltage transformers, junction boxes, DC and AC electrical collection systems, a Project substation, and gen-tie lines. The Project's approximately 260,000 PV solar modules will be supported by racking systems and oriented in rows running north to south. The racking system will be supported by approximately 50,000 steel posts installed with a combination of pile-driving machines and augers. The center height of the racking structures will be approximately four feet to eight feet above the ground. The highest point of each module will be approximately 20 feet above the ground. The modules will be connected using DC cables that can either be buried in a trench or attached to the racking system. The DC cables gather at the end of racking systems to combiner boxes which are connected to cables routing to an inverter.

7. Additionally, the Project will include an onsite transmission line, fiber optic cable for communications either underground or on overhead lines, a meteorological station mounted on

a concrete foundation, interior access ways, and a facility perimeter road. The Project will include, as necessary, an operation and maintenance (“O&M”) building, parking area, and other associated facilities such as above-ground water storage tanks, security gate, signage, and flagpoles. During construction, the Project will include a temporary construction mobilization and laydown area for construction trailers, construction workforce parking, above ground water and fuel tanks, materials receiving, and materials storage.

8. Approximately 38 inverters will be installed throughout the Project to convert the DC power from the 1,500-volt DC collection system to AC power, which will then be transmitted to the Project substation via the 34.5-kilovolt (kV) AC collection system. The AC collection system will include underground and/or overhead segments. Underground segments of the AC collection system will be buried a minimum of three feet below grade; and overhead portions will not exceed a maximum height of 45 feet above grade. The AC collection system will be comprised of medium voltage (MV) cable that will transfer electricity to the Project substation. Approximately 360,000 linear feet of DC collection system cables and 90,000 linear feet of AC collection cables would be installed throughout the Project. Collection cables are congregated into common trenches and run adjacent to one another. All electrical inverters and medium voltage transformers will be placed on concrete foundations or steel piles.

9. The Project will require one onsite substation that will include one 127-mega volt ampere (MVA) transformer and all necessary equipment to convert and boost incoming MV electricity to the high voltage electricity necessary to interconnect via an approximately 13,523-foot nonregulated electric transmission line to be constructed between the Project footprint and the existing 138kV Central Hardin substation owned and operated by EKPC. It is anticipated that the gen-tie poles and substation components will not exceed 110 feet above grade.

III. Public Notice Evidence

10. Pursuant to KRS 278.706(2)(c), public notice of the filing of this application was provided to adjacent landowners and magistrates (Exhibit B-1) on July 21 and 22, 2022 and to the general public via publication in The News Enterprise, which is the newspaper of general circulation in Hardin County, on July 23, 2022. (Exhibit B-2).

11. Letters were mailed to the adjacent landowners on October 28, 2021, to provide notice of the public information meeting held on November 11, 2021. An example of the letter and delivery proof to the adjacent landowners and magistrates can be found in Exhibit B-3 as well as a scanned copy of the notice of the public information meeting that was published in The News Enterprise on October 28, 2021, in Exhibit B-4.

IV. Compliance with Local Ordinance and Regulations

12. Pursuant to KRS 278.706(2)(d), Hardin County has promulgated the Hardin County Development Guidance System Zoning Ordinance, 2009 (hereinafter “the Ordinance”) and the Applicant has designed the Project to be consistent with the applicable Ordinance requirements. The Applicant certifies that the Project will comply with all local ordinances and regulations concerning noise control and with any applicable local planning and zoning ordinances. Pursuant to KRS 278,704(3), the following setbacks were established by the Ordinance: on property zoned as I-2, Hardin County requires a minimum front yard setback of 50 feet; minimum side yard setback of 20 feet, or 40 feet if adjoining commercial/industrial zones and 100 feet if adjoining residential and agricultural zones; minimum rear yard setback of 35 feet; or 40 feet if adjoining commercial/industrial zones, and 100 feet if adjoining residential and agricultural zones. The

signed Statement of Compliance is contained in Exhibit C. The Ordinance is enclosed as SAR Exhibit F.

V. Setback Requirements

13. Pursuant to KRS 278.706(2)(e), the Project will not include any exhaust stacks or wind turbines as part of the facility; the Project will not be required to follow setback requirements set forth in KRS 278.704(3), from the property boundary of any adjoining property owner to the energy generating facilities as a result of the locally established setback requirements.

14. The Applicant retained Kirkland Appraisals, LLC, to assess potential effects of the Project on nearby property values. The matched pair analysis shows no impact on home values due to abutting or adjoining a solar facility, as well as no impact to abutting or adjacent vacant residential or agricultural land where the Project is properly screened and buffered. The adjoining properties have sufficient setbacks from the proposed solar panels and supplemental vegetation is proposed to enhance the areas where the existing trees are insufficient to provide proper screening.

VI. Public Notice Report

15. Pursuant to KRS 278.706(2)(f), the Applicant has made a substantial effort to engage the public in numerous ways regarding the Project. Stonefield Solar has created a Project website (<https://stonefieldsolar.com/>) to publish information about the Project and to provide an email and telephone number for feedback. It has held in-person public meetings, online public meetings, in-person meetings with media, county officials, and neighboring residents. In all communications, Stonefield Solar has endeavored to be transparent regarding the specifics of the proposed Project.

16. A public in-person meeting was held at 6:00 PM on November 11, 2021, at the Central Kentucky Community Foundation's Home of Philanthropy in Elizabethtown, about seven miles from the proposed Project site, to inform the public about the Project and receive comments from the public. A notice announcing the public meeting was published in The News Enterprise on October 28, 2021 (Exhibit B-4). Additionally, notice was mailed to adjacent property owners on October 28, 2021 (Exhibit B-3)

17. The meeting was attended by the following members of Candela Renewables, the parent company of the Applicant:

- James Cook, VP of Project Development
- Roy Skinner, VP of Project Siting and Execution
- Rick Ferrera, Senior Manager of Development
- Matt Kiehlmeier, Manager of Real Estate

Also present were subject matter experts who are heavily involved in the Stonefield Solar Project:

- Mark Carney, Managing Director at e3rm
- David Lamb, P.E., President at Associated Engineers

Approximately 40 members of the public attended the meeting, which was an open house format with informational poster boards spaced around the room. Stationed next to each poster board were 1-2 of the Project representatives who were available to answer questions from the community. The contents of the poster boards presented at the meeting included information about the Applicant, an overview of utility-scale solar development, a map of the Project showing a preliminary layout plan, the anticipated permitting timeline and construction schedule, the Applicant's active development portfolio, property tax benefits, and a visual simulation of a viewshed from the Project. The presentation materials and an attendance list from the public meeting are included in Exhibit B-5. The following is a brief description of other public involvement activities, in addition to the public meeting and various outreach activities/meetings

with local stakeholders, undertaken prior to the submission of this Application. Stonefield Solar will continue these efforts and will participate in any public notice, comment, and hearings which may be initiated as part of ongoing permitting activities.

Table 1. Public Involvement Activities

Date	Event	Audience	Notes
3/1 – 8/31/2021	Meetings with Hardin County Planning Director and Hardin County Engineer	Hardin County	Multiple meetings with Hardin County Planning Director and Hardin County Engineer to discuss the project’s development site plan.
11/2/2021	Virtual Presser	Public	The Applicant participated in a moderated virtual presser to provide the media information about the emerging solar development in Hardin County. Participating panelists included the President/COO of the Elizabethtown-Hardin County Industrial Foundation, and Former USDA Rural Development State Director under the Trump Administration. Hardin County Deputy Judge and Nolin RECC’s CEO also provided statements to be read during the event.
10/28/2021	Mailing	Adjacent Landowners	Public Information meeting notice letter
10/28/2021	The News Enterprise	Public Newspaper Advertisement	Public Notice of informational meeting
11/12/2021	Public Meeting	Public	Informational meeting about the Project to give the public a chance to engage with project representatives and ask questions .
11/13/2021	The News Enterprise	Public Newspaper Article	An article in the local newspaper, The News Enterprise, circulated on Nov. 13th, 2021, providing testimonials from attendees at the Project’s public meeting.
4/21/2022	Multicultural Fair	Public	Elizabethtown Community and Technical College hosted a Multicultural Fair and invited the Project team to setup as part of an Earth Day exhibit.
6/16/2022	Meeting with Hardin County Planning Director and Hardin County Engineer	Hardin County	Meeting with Hardin County Planning Director and Hardin County Engineer to discuss the Project’s development site plan.
6/16/2022	Meeting with KY Trans Cab District 4 Representative	Kentucky Transportation Cabinet	Meeting with Kentucky Transportation Cabinet District 4 Representative to discuss the Project’s development site plan.

7/21-22/2022	Mailing	Adjacent Landowners	Application Filing letter
7/23/2022	The News Enterprise	Public Newspaper Advertisement	Public Notice of Application Filing

VII. Efforts to Locate Near Existing Electric Generation

18. Consistent with KRS 278.706(2)(g), Stonefield Solar took into account whether the proposed solar project could be located on, adjoining, or in proximity to the location of existing electric generating facilities. For solar projects like Stonefield Solar, key factors for site selection are favorable geography, willing landowner participation, and access to transmission lines. The land needed to site Stonefield Solar was not available on or adjoining to an existing electric generation facility. However, Stonefield Solar selected a location in proximity to an existing transmission line.

19. The onsite substation will connect to the existing electric grid via an approximately 13,523-foot nonregulated electric transmission line to be constructed between the Project footprint and the existing 69 kV Central Hardin Substation, owned and operated by EKPC. Information on PJM's studies of the interconnection cost and infrastructure are included in the System Impact Study included in Exhibit D.

VIII. Proof of Service to County and Municipality Officials

20. Pursuant to KRS 278.706(2)(h), a copy of the Siting Board application for Stonefield Solar, LLC, was electronically transmitted to the Judge-Executive of Hardin County, Harry Berry, the chief executive officer of the county in which the proposed generating facility is to be located. The proposed facility is not being located within the boundaries of any municipal corporation. It also has been served on the Chairman of the Hardin County Planning &

Development Commission, Mark Hinton, the chief officer of the public agency charged with the duty of planning land use in Hardin County, on August 19, 2022. Proof of this service is provided in Exhibit B-6.

IX. Effect on Kentucky Electricity Generation System

21. Pursuant to KRS 278.706(2)(i), the Project is within EKPC's service territory, and therefore, the interconnection of the Project will be on the EKPC system. An analysis of the proposed solar generating facility's projected effect on the electricity transmission system is provided in Exhibit D.

X. Effect on Local and Regional Economies

22. Pursuant to KRS 278.706(2)(j), an Economic Impact Study was completed for the Project by Strategic Economic Research enclosed as Exhibit E. As the study demonstrates, utility-scale solar energy projects have numerous economic benefits. Solar installations create job opportunities in the local area during both the short-term construction phase and the long-term operational phase. In addition to the workers directly involved in the construction and maintenance of the solar energy project, numerous other jobs are supported through indirect supply chain purchases and the higher spending that is induced by these workers. Solar projects strengthen the local tax base and help improve county services, and local infrastructure such as public roads.

23. According to the Economic Impact Study, the Project is projected to create 93 local (Hardin County) jobs during construction and the equivalent of 7.6 full time local, long term jobs during operation. To the extent feasible, jobs will be sourced locally. The Project is anticipated to create over \$6,500,000 in new local earnings during construction and another \$290,000 in new local long-term earnings; and a local output of more than \$8,000,000 during construction and

\$1,000,000 during operation. In addition, the Project is projected to raise the local tax base by \$2,400,000 over the life of the Project. See Exhibit E for a full report on the impact of the Project on local and regional economies.

XI. Record of Environmental Violations

24. Pursuant to KRS 278.706(2)(k), neither the Applicant, nor any entity with ownership interest in the Project, has violated any state or federal environmental laws or regulations. There are no pending actions, judicial or administrative, against the Applicant nor any entity with ownership interest in the Project.

XII. Site Assessment Report

25. Pursuant to KRS 278.706(2)(l), the Site Assessment Report (SAR) is being contemporaneously filed herewith; please see the separate document titled “Stonefield Solar, LLC, Kentucky State Board on Electric Generation and Transmission Application, Site Assessment Report, Case No. 2022-00011”, August 2022 and labeled as Exhibit F to this application.

Dated this 19th day of August 2022.

Respectfully submitted,

FROST BROWN TODD LLC



Gregory T. Dutton
FROST BROWN TODD LLC
400 W. Market Street, 32nd Floor
Louisville, KY 40202
(502) 589-5400
(502) 581-1087 (fax)
gddutton@fbtlaw.com
Counsel for Stonefield Solar, LLC

**Statutory/Regulation Requirements
General ESB Certificate**

KRS 278.	Description	Filing
278.706(2)(a)	The name, address, and telephone number of the person proposing to construct and own the merchant generating facility.	Application ¶1
(2)(b)	A full description of the proposed site, including a map showing the distance of the proposed site from residential neighborhoods, the nearest residential structures, schools, and public and private parks that are located within a two (2) mile radius of the proposed facility.	Application ¶¶2-9, Exhibit A
(2)(c)	Evidence of public notice that shall include the location of the proposed site and a general description of the project, state that the proposed line is subject to approval by the board, and provide the telephone number and address of the Public Service Commission. Public notice shall be given within thirty (30) days immediately preceding the application filing to: <ul style="list-style-type: none"> 1. Landowners whose property borders the proposed site; and 2. The general public in a newspaper of general circulation in the county or municipality in which the facility is to be located. 	Application ¶¶10-11, Exhibit B-1, B-2
(2)(d)	A statement certifying that the proposed plant will be in compliance with all local ordinances and regulations concerning noise control and with any local planning and zoning ordinances. The statement shall also disclose setback requirements established by the planning and zoning Commission as provided under KRS 278.704(3).	Application ¶12, Exhibit C
(2)(e) [1st]	If the facility is not proposed to be located on a site ... in an area where a planning and zoning commission has established a setback requirement pursuant to KRS 278.704(3), a statement that ... all proposed structures or facilities used for generation of electricity are two thousand (2,000) feet from any residential neighborhood, school, hospital, or nursing home facility....	N/A
(2)(e) [2nd]	If the facility is proposed to be located on a site of a former coal processing plant and the facility will use on-site waste coal as a fuel source, a statement that the proposed site is compatible with the setback requirements provided under KRS 278.704(5).	N/A
(2)(e) [3rd]	If the facility is proposed to be located in a jurisdiction that has established setback requirements pursuant to KRS 278.704(3), a statement that the proposed site is in compliance with those established setback requirements.	Application ¶12, Exhibit C

(2)(f)(1)	A complete report of the applicant's public involvement program activities undertaken prior to the filing of the application, including: The scheduling and conducting of a public meeting in the county or counties in which the proposed facility will be constructed at least ninety (90) days prior to the filing of an application, for the purpose of informing the public of the project being considered and receiving comment on it.	Application ¶¶15-17, Exhibit B-3, B-4, B-5
(2)(f)(2)	Evidence that notice of the time, subject, and location of the meeting was published in the newspaper of general circulation in the county, and that individual notice was mailed to all owners of property adjoining the proposed project at least two (2) weeks prior to the meeting.	Application ¶¶15-17, Exhibit B-3, B-4
(2)(f)(3)	Any use of media coverage, direct mailing, fliers, newsletters, additional public meetings, establishment of a community advisory group, and any other efforts to obtain local involvement in the siting process.	Application ¶¶15-17, Exhibit B-5
(2)(g)	A summary of the efforts made by the applicant to locate the proposed facility on a site where existing electric generating facilities are located.	Application ¶¶18-19, Exhibit D
(2)(h)	Proof of service of a copy of the application upon the chief executive officer of each county and municipal corporation in which the proposed line is to be located, and upon the chief officer of each public agency charged with the duty of planning land use in the general area in which the line is proposed to be located.	Application ¶20, Exhibit B-6
(2)(i)	An analysis of the proposed facility's projected effect on the electricity transmission system in Kentucky.	Application ¶21, Exhibit D
(2)(j)	An analysis of the proposed facility's economic impact on the affected region and the state.	Application ¶22-23, Exhibit E
(2)(k)	A detailed listing of all violations by it, or any person with an ownership interest, of federal or state environmental laws, rules, or administrative regulations, whether judicial or administrative, where violations have resulted in criminal convictions or civil or administrative fines exceeding five thousand dollars (\$5,000). The status of any pending action, whether judicial or administrative, shall also be submitted.	Application ¶24
(2)(l)	A site assessment report as specified in KRS 278.708.	Application ¶25
278.704(2)	Except as provided [by locally-established setback requirements or through a deviation granted pursuant to KRS 278.704(4)] ... all proposed structures or facilities used for generation of electricity are two thousand (2,000) feet from any residential neighborhood, school, hospital, or nursing home facility.	Application ¶13

.704(3)	If the merchant electric generating facility is proposed to be located in a county or a municipality with planning and zoning, then setback requirements from a property boundary, residential neighborhood, school, hospital, or nursing home facility may be established by the planning and zoning commission.	Application ¶¶12-13, Exhibit C
278.708(1)	A site assessment report...as required under KRS 278.706(2)(1).	Application ¶25, Exhibit F
.708(2)	A site assessment report...prepared by the applicant or its designee.	Application Exhibit F
.708(3)(a)	A description of the proposed facility that shall include a proposed site development plan that describes: <ol style="list-style-type: none"> 1. Surrounding land uses for residential, commercial, agricultural, and recreational purposes; 2. The legal boundaries of the proposed site; 3. Proposed access control to the site; 4. The location of facility buildings, transmission lines, and other structures; 5. Location and use of access ways, internal roads, and railways; 6. Existing or proposed utilities to service the facility; 7. Compliance with applicable setback requirements as provided under KRS 278.704(2), (3), (4), or (5); and 8. Evaluation of the noise levels expected to be produced by the facility. 	SAR ¶¶1-10, Exhibit A, SAR Exhibit A, A-1, C, D, F
(3)(b)	An evaluation of the compatibility of the facility with scenic surroundings;	SAR ¶11, SAR Exhibit B
(3)(c)	The potential changes in property values and land use resulting from the siting, construction, and operation of the proposed facility for property owners adjacent to the facility.	SAR ¶12, SAR Exhibit B
(3)(d)	Evaluation of anticipated peak and average noise levels associated with the facility's construction and operation at the property boundary; and	SAR ¶¶13-15, SAR Exhibit D
(3)(e)	The impact of the facility's operation on road and rail traffic to and within the facility, including anticipated levels of fugitive dust created by the traffic and any anticipated degradation of roads and lands in the vicinity of the facility.	SAR ¶¶ 6-18, SAR Exhibit E, G
.708(4)	The site assessment report shall also suggest any mitigating measures to be implemented by the applicant to minimize or avoid adverse effects identified in the site assessment report.	SAR ¶¶19-23

EXHIBIT A

C:\Users\stacoleman\OneDrive - Stantec\Office 365\PROJECTS\KY_Solar_Noise\mapping\stomellied_2m\map.mxd Revised: 2022-08-10 By: acoleman

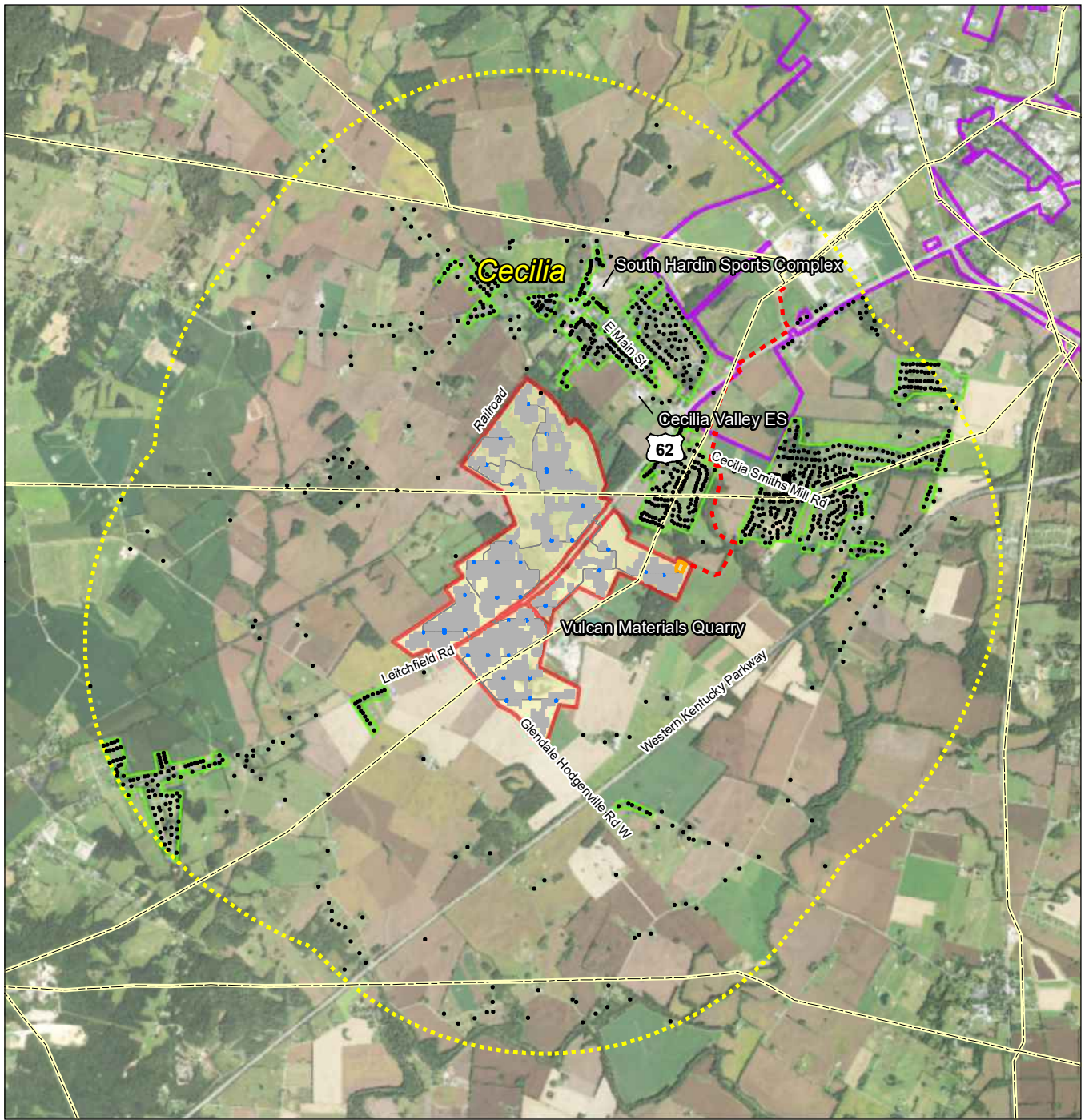

- Legend**
- Residential Structures
 - Electrical Power Transmission Lines
 - ⋯ 2 Mile Buffer
 - Proposed Access Roads
 - Proposed PV Layout
 - Proposed Inverter Locations
 - Proposed Substation Location
 - Proposed Gen-Tie
 - Project Footprint Area
 - Residential Neighborhood per KRS 278.700
 - Elizabethtown Municipal Limits

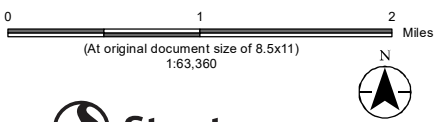

Project Location: Cecilia, KY
 Prepared by ALC on 2022-08-02
 TR by JA on 2022-08-02

Client/Project: Stonefield Solar Facility Project Site
 172658271 REV B

Figure No.: **Exhibit A (Application)**
 Title: **Stonefield Solar Project**

Notes
 1. Coordinate System: NAD 1983 2011 StatePlane Kentucky South FIPS 1602 Ft US
 2. Data Sources: ESRI, Stantec
 3. Background: KY NAIP 2018

Disclaimer: This document has been prepared based on information provided by others as cited in the Notes section. Stantec has not verified the accuracy and/or completeness of this information and shall not be responsible for any errors or omissions which may be incorporated herein as a result. Stantec assumes no responsibility for data supplied in electronic format, and the recipient accepts full responsibility for verifying the accuracy and completeness of the data.

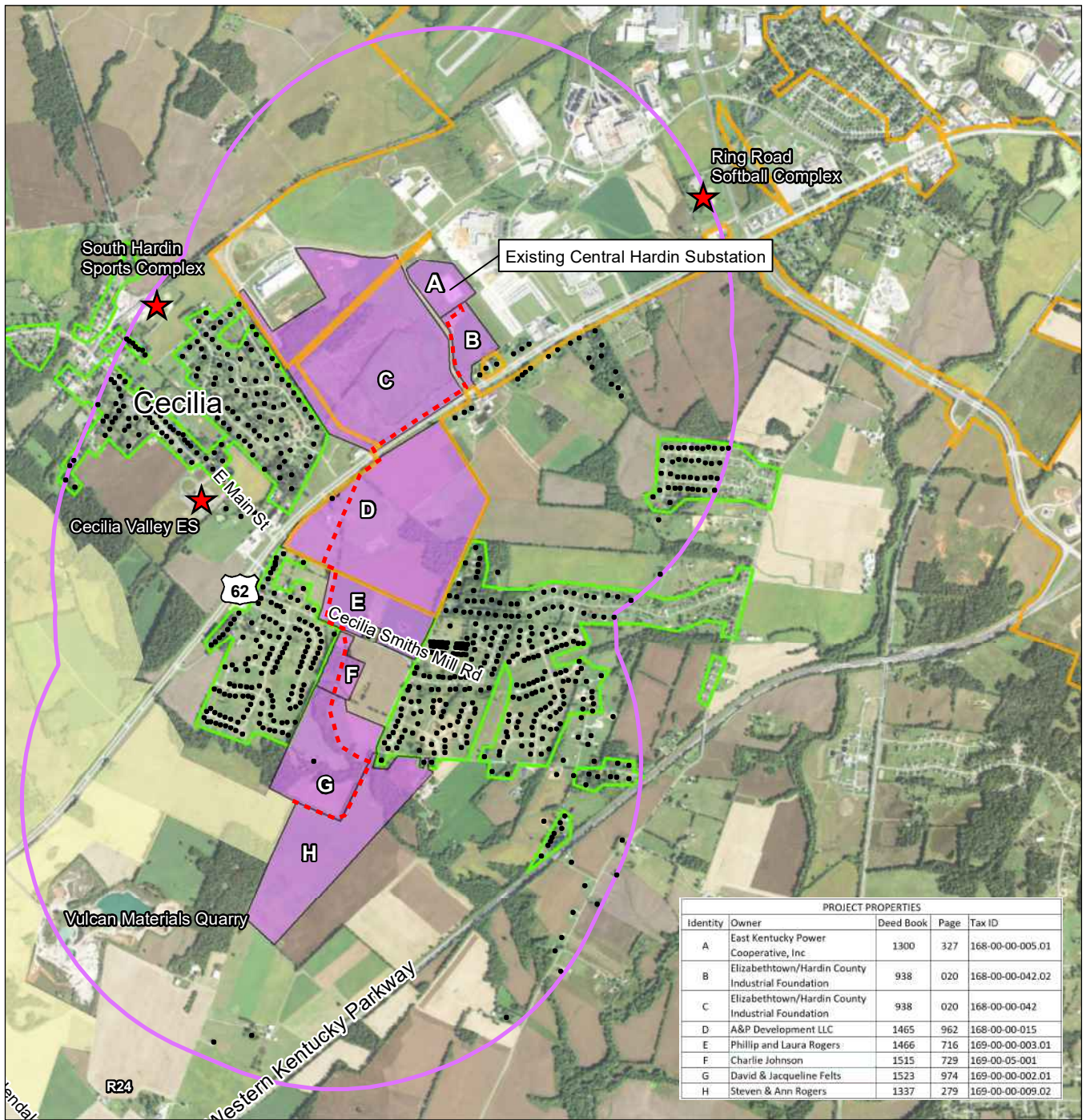

Legend

- Residential Structures within 1 mile
- ★ Schools and Recreation Areas
- - - Proposed Gen-Tie
- 1 Mile Transition Line Radius Boundary
- ▭ Elizabethtown Municipal Limits
- ▭ Parcels Crossed by Transmission Line
- ▭ Project Footprint Area
- ▭ Residential Neighborhood per KRS 278.700

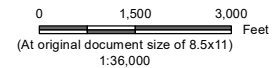

Project Location: Cecilia, KY
 Client/Project: 172658271 REVA

Prepared by ALC on 2022-08-02
 TR by JA on 2022-08-02

Stonefield Solar Facility
 Gen-Tie Parcel Map

Figure No. **Exhibit A-1 (Application)**

Title **Stonefield Solar Project**

Notes
 1. Coordinate System: NAD 1983 2011 StatePlane Kentucky South FIPS 1602 Ft US
 2. Data Sources: ESRI, Stantec
 3. Background: KY NAIP 2018

Exhibit B-1



Dear Neighbor,

As you are likely aware, Stonefield Solar, LLC, is proposing to develop, construct and operate an approximately 120-megawatt solar merchant electric generating facility and nonregulated transmission line to be located in Hardin County, Kentucky. The proposed solar project will be situated on approximately 1,030 acres and will consist of photovoltaic panels and their associated racking systems, inverters, collection system, transmission line, project substation and other project equipment. The project will connect to a substation to be constructed on site. The substation will connect to the existing electric grid via an approximately 13,523-foot nonregulated transmission line to be constructed between the project footprint and the existing Central Hardin Substation located on Pritchard Parkway in Elizabethtown.

Stonefield Solar, LLC (Case No. 2022-00011), is required to file an application with the Kentucky Electric Generation and Transmission Siting Board (“Board”) to obtain a certificate for the construction of the proposed merchant electric generating facility and nonregulated electric transmission line. This filing will occur in the coming weeks. This proposed construction is subject to approval by the Board, which can be reached at P.O. Box 615, 211 Sower Boulevard, Frankfort, Kentucky 40602-0615, or via phone at (502) 564-3940.

Please feel free to contact us if you have any questions.

Best regards,

A handwritten signature in black ink that reads "Rick Ferrera".

Rick Ferrera
Senior Manager, Project Development

Phone: (270) 681-5720
Email: info@stonefieldsolar.com
Company Website: www.candelarenewables.com
Project Website: stonefieldsolar.com

Exhibit B-1 - Stonefield Solar - Adj Landowner Letter & Notices

Landowner	Tracking Information	City	Stat	Zip	Delivered	Parcel ID
BUCHANAN DONALD G -ETAL-	USPS 7022 0410 0001 3131 2038	Elizabethtown	KY	42701	Delivery Attempted	148-00-00-011
ROGERS CLARENCE M -ETAL-	USPS 7022 0410 0001 3131 2021	Glendale	KY	42740	Delivered to Agent for Final Delivery	148-00-00-012.01 & 148-00-00-012
WALTZ JACOB	USPS 7022 0410 0001 3131 2045	Glendale	KY	42740	Delivered to Agent for Final Delivery	149-00-00-003
ROGERS STEVEN C & ANN D	USPS 7022 0410 0001 3131 2014	Glendale	KY	42740	Delivered to Agent for Final Delivery	149-00-00-004 & 169-00-00-009.02
SIMCOE J DAVID	USPS 7022 0410 0001 3131 2007	Glendale	KY	41740	Delivered to Agent for Final Delivery	149-00-00-001
CLARK JAMES KEVIN & CHARLOTTE ANN	USPS 7022 0410 0001 3131 1994	Cecilia	KY	42724	Delivered, Left with Individual	148-00-00-013
DORIS CLAIBORNE LLC &	USPS 7022 0410 0001 3131 1987	Vernon Hills	IL	60061	Delivery Attempted	126-00-00-021
DAVIS GEORGE A LIVING TRUST	USPS 7022 0410 0001 3131 1970	Cecilia	KY	42724	Delivered, Left with Individual	148-00-00-008
CHILDERS JUSTIN & SHANNON	USPS 7022 0410 0001 3131 1963	Cecilia	KY	42724	Delivered, Left with Individual	148-00-00-009
GREY CLAYTON & GERALDINE &	USPS 7022 0410 0001 3131 1956	Cecilia	KY	42724	Delivered, Left with Individual	148-00-00-002
KUTCHER ANDREW J	USPS 7022 0410 0001 3131 1949	Cecilia	KY	42724	Delivery Attempted	168-00-00-007
BRYANT SCOTT M & MICHELLE L	USPS 7022 0410 0001 3131 1932	Cecilia	KY	42724	Delivery Attempted	168-00-00-008
PRESTON THERESA K	USPS 7022 0410 0001 3131 1925	Cecilia	KY	42724	Notice Left (No Authorized Recipient Available)	168-00-00-009
JEWELL JOSHUA T & CYNTHIA M	USPS 7022 0410 0001 3131 1918	Cecilia	KY	42724	Delivered, Left with Individual	168-00-00-010
TAUL JOANN REVOCABLE LIVING TRUST	USPS 7022 0410 0001 3131 1901	Elizabethtown	KY	42701	Delivered to Agent for Final Delivery	168-20-00-035.02
GOODMAN RANDALL & DEBROAH	USPS 7022 0410 0001 3131 1895	Cecilia	KY	42724	Notice Left (No Authorized Recipient Available)	168-00-00-011
HALL SEAN C & RENA	USPS 7022 0410 0001 3131 1888	Cecilia	KY	42724	Notice Left (No Authorized Recipient Available)	169-00-00-001.01
BACK FORTY RENTALS LLC	USPS 7022 0410 0001 3131 1871	Sonora	KY	42776	Delivered, Left with Individual	169-00-02-075
	USPS 7022 0410 0001 3131 XXXX- receipt torn	Cecilia	KY	42724		169-00-02-076
SPEARS MICAH RODNEY &		Cecilia	KY	42724	Delivered, Left with Individual	169-00-02-077
CLINE JASON L & LIA C	USPS 7022 0410 0001 3131 1857	Cecilia	KY	42724	Delivered, Left with Individual	169-00-02-111
WEEDY REBEKAH	USPS 7022 0410 0001 3131 1840	Cecilia	KY	42724	Delivered, Left with Individual	169-00-02-112
SKAGGS JESSE & ANLEY	USPS 7022 0410 0001 3131 1833	Cecilia	KY	42724	Delivered, Left with Individual	169-00-02-113
WILLITS JERIMIAH & DESTINI	USPS 7022 1670 0001 5081 6132	Cecilia	KY	42724	Delivered, Individual Picked Up at Post Office	169-00-02-121
REED W DOUGLAS & DONNA K	USPS 7022 0410 0001 5081 6125	Cecilia	KY	42724	Delivery Attempted	169-00-00-002.01
FELTS DAVID R & JACQUELINE J	USPS 7022 1670 0001 5081 6118	Cecilia	KY	42724	Delivered, Individual Picked Up at Post Office	168-20-00-036.02 & 168-20-00-037
WILDCAT PROPERTIES LLC	USPS 7022 1670 0001 5081 6101	Elizabethtown	KY	42701	Delivered, Left with Individual	147-00-00-044.01
LUSH DOUGLAS H 7 SHARMIN H	USPS 7022 1670 0001 5081 6095	Cecilia	KY	42724	Delivery Attempted	148-00-00-002
GREY CLAYTON L & GERALDINE H	USPS 7022 1670 0001 5081 6323	Cecilia	KY	42724	Delivered, Left with Individual	147-00-00-028 & 147-00-00-028.04
SEXTON DONALD R & LINDA R	USPS 7022 1670 0001 5081 6316	Cecilia	KY	42724	Delivered, Left with Individual	147-00-00-028.01
YATES DAVID L & CLARISSA G	USPS 7022 1670 0001 5081 6039	Cecilia	KY	42724	Delivery Attempted	148-00-00-006
WAUGH, Jimmy N	USPS 7022 1670 0001 5081 6293	Cecilia	KY	42724	Delivered, Left with Individual	169-00-02-110
GARDNER JACKIE R	USPS 7022 1670 0001 5081 6194	Cecilia	KY	42724	Delivery Attempted	
Buchanan Reba et al	USPS 7022 1670 0001 5081 6187	Elizabethtown	KY	42701	Delivery Attempted	
Buchanan Property Group, LLC	USPS 7022 1670 0001 5081 6170	Elizabethtown	KY	42701	Delivery Attempted	
Dr Christopher and DaneNell Knight	USPS 7022 1670 0001 5081 6163	Elizabethtown	KY	42701	Delivery Attempted	
KYTC District 4 Attn: Jacob Riggs	USPS 7022 1670 0001 5081 6156	Elizabethtown	KY	42701	Delivered, Front Desk/Reception/Mail Room	
KYTC Central Office	USPS 7022 1670 0001 5081 6149	Frankfort	KY	40622	Delivered, Individual Picked Up at Postal Facility	
District 1 Magistrate- Roy Easter	USPS 7022 0410 0001 3192 6321	Radcliff	KY	40160	Delivery Attempted	
District 2 Magistrate- Doug Goodman	USPS 7022 0410 0001 3129 6338	Radcliff	KY	40159	Delivered, Individual Picked Up at Post Office	
District 3 Magistrate- Lisa Williams	USPS 7022 0410 0001 3129 6345	Elizabethtown	KY	42701	Delivered, Individual Picked Up at Post Office	
District 4 Magistrate- Fred Clem, Jr.	USPS 7022 0410 0001 3129 6369	Elizabethtown	KY	42701	Delivery Attempted	
District 5 Magistrate- Bill Wiseman	USPS 7022 0410 0001 3129 6314	Elizabethtown	KY	42701	Delivery Attempted	
District 6 Magistrate- E.G. Thompson	USPS 7022 0410 0001 3129 6352	Elizabethtown	KY	42701	Delivered, Left with Individual	
District 7 Magistrate- Ronnie Goodman	USPS 7022 0410 0001 3129 6284	Cecilia	KY	42724	Delivered, Left with Individual	
District 8 Magistrate- Garry King	USPS 7022 0410 0001 3129 6277	Vine Grove	KY	40175	Delivered, Left with Individual	

7022 0410 0001 3129 6345

U.S. Postal Service™ CERTIFIED MAIL® RECEIPT

Domestic Mail Only

For delivery information, visit our website at www.usps.com™.

OFFICIAL USE

Certified Mail Fee

\$

Extra Services & Fees (check box, add fee as appropriate)

- Return Receipt (hardcopy) \$
- Return Receipt (electronic) \$
- Certified Mail Restricted Delivery \$
- Adult Signature Required \$
- Adult Signature Restricted Delivery \$

Postmark Here
JUL 21 2022

Postage

\$

Total Postage and Fees

\$

Sent To

Lisa Williams

Street and Apt. No., or PO Box No.

73 Whispering Pine Way

City, State, ZIP+4®

Elizabethtown, KY 40322

PS Form 3800, April 2015 PSN 7530-02-000-9047

See Reverse for Instructions

7022 0410 0001 3129 6321

U.S. Postal Service™ CERTIFIED MAIL® RECEIPT

Domestic Mail Only

For delivery information, visit our website at www.usps.com™.

OFFICIAL USE

Certified Mail Fee

\$

Extra Services & Fees (check box, add fee as appropriate)

- Return Receipt (hardcopy) \$
- Return Receipt (electronic) \$
- Certified Mail Restricted Delivery \$
- Adult Signature Required \$
- Adult Signature Restricted Delivery \$

Postmark Here
JUL 21 2022

Postage

\$

Total Postage and Fees

\$

Sent To

Roy Easter

Street and Apt. No., or PO Box No.

1420 Hunters Lane

City, State, ZIP+4®

Radcliff, KY 40160

PS Form 3800, April 2015 PSN 7530-02-000-9047

See Reverse for Instructions

7022 0410 0001 3129 6369

U.S. Postal Service™ CERTIFIED MAIL® RECEIPT

Domestic Mail Only

For delivery information, visit our website at www.usps.com™.

OFFICIAL USE

Certified Mail Fee

\$

Extra Services & Fees (check box, add fee as appropriate)

- Return Receipt (hardcopy) \$
- Return Receipt (electronic) \$
- Certified Mail Restricted Delivery \$
- Adult Signature Required \$
- Adult Signature Restricted Delivery \$

Postmark Here
JUL 21 2022

Postage

\$

Total Postage and Fees

\$

Sent To

Fred Clem, Jr.

Street and Apt. No., or PO Box No.

365 Timber Lane

City, State, ZIP+4®

Elizabethtown, KY 40301

PS Form 3800, April 2015 PSN 7530-02-000-9047

See Reverse for Instructions

7022 0410 0001 3129 6338

U.S. Postal Service™ CERTIFIED MAIL® RECEIPT

Domestic Mail Only

For delivery information, visit our website at www.usps.com™.

OFFICIAL USE

Certified Mail Fee

\$

Extra Services & Fees (check box, add fee as appropriate)

- Return Receipt (hardcopy) \$
- Return Receipt (electronic) \$
- Certified Mail Restricted Delivery \$
- Adult Signature Required \$
- Adult Signature Restricted Delivery \$

Postmark Here
JUL 21 2022

Postage

\$

Total Postage and Fees

\$

Sent To

Doug Goodman

Street and Apt. No., or PO Box No.

PO Box 304

City, State, ZIP+4®

Radcliff, KY 40159

PS Form 3800, April 2015 PSN 7530-02-000-9047

See Reverse for Instructions

7022 0410 0001 3129 6352

**U.S. Postal Service™
CERTIFIED MAIL® RECEIPT**
Domestic Mail Only

For delivery information, visit our website at www.usps.com®.

OFFICIAL USE

Certified Mail Fee
\$

Extra Services & Fees (check box, add fee as appropriate)

<input type="checkbox"/> Return Receipt (hardcopy)	\$
<input type="checkbox"/> Return Receipt (electronic)	\$
<input type="checkbox"/> Certified Mail Restricted Delivery	\$
<input type="checkbox"/> Adult Signature Required	\$
<input type="checkbox"/> Adult Signature Restricted Delivery	\$

Postage
\$

Total Postage and Fees
\$

Sent To **E. G. Thompson**
Street and Apt. No., or PO Box No.
672 Beasley Boulevard
City, State, ZIP+4®
Elizabethtown, KY 42701

PS Form 3800, April 2015 PSN 7530-02-000-9047 See Reverse for Instructions

7022 0410 0001 3129 6277

**U.S. Postal Service™
CERTIFIED MAIL® RECEIPT**
Domestic Mail Only

For delivery information, visit our website at www.usps.com®.

OFFICIAL USE

Certified Mail Fee
\$

Extra Services & Fees (check box, add fee as appropriate)

<input type="checkbox"/> Return Receipt (hardcopy)	\$
<input type="checkbox"/> Return Receipt (electronic)	\$
<input type="checkbox"/> Certified Mail Restricted Delivery	\$
<input type="checkbox"/> Adult Signature Required	\$
<input type="checkbox"/> Adult Signature Restricted Delivery	\$

Postage
\$

Total Postage and Fees
\$

Sent To **Garry King**
Street and Apt. No., or PO Box No.
1004 Muirfield Court
City, State, ZIP+4®
Vine Grove, KY 40175

PS Form 3800, April 2015 PSN 7530-02-000-9047 See Reverse for Instructions

7022 0410 0001 3129 6314

**U.S. Postal Service™
CERTIFIED MAIL® RECEIPT**
Domestic Mail Only

For delivery information, visit our website at www.usps.com®.

OFFICIAL USE

Certified Mail Fee
\$

Extra Services & Fees (check box, add fee as appropriate)

<input type="checkbox"/> Return Receipt (hardcopy)	\$
<input type="checkbox"/> Return Receipt (electronic)	\$
<input type="checkbox"/> Certified Mail Restricted Delivery	\$
<input type="checkbox"/> Adult Signature Required	\$
<input type="checkbox"/> Adult Signature Restricted Delivery	\$

Postage
\$

Total Postage and Fees
\$

Sent To **Bill Wiseman**
Street and Apt. No., or PO Box No.
315 Churchill Court
City, State, ZIP+4®
Elizabethtown, KY 42701

PS Form 3800, April 2015 PSN 7530-02-000-9047 See Reverse for Instructions

7022 0410 0001 3129 6284

**U.S. Postal Service™
CERTIFIED MAIL® RECEIPT**
Domestic Mail Only

For delivery information, visit our website at www.usps.com®.

OFFICIAL USE

Certified Mail Fee
\$

Extra Services & Fees (check box, add fee as appropriate)

<input type="checkbox"/> Return Receipt (hardcopy)	\$
<input type="checkbox"/> Return Receipt (electronic)	\$
<input type="checkbox"/> Certified Mail Restricted Delivery	\$
<input type="checkbox"/> Adult Signature Required	\$
<input type="checkbox"/> Adult Signature Restricted Delivery	\$

Postage
\$

Total Postage and Fees
\$

Sent To **Ronnie Gooden**
Street and Apt. No., or PO Box No.
475 Meadowview Lane
City, State, ZIP+4®
Cecilia, KY 42724

PS Form 3800, April 2015 PSN 7530-02-000-9047 See Reverse for Instructions

7022 0410 0001 3131 1671

U.S. Postal Service™
CERTIFIED MAIL® RECEIPT
Domestic Mail Only

For delivery information, visit our website at www.usps.com®.

OFFICIAL USE

Certified Mail Fee

\$

Extra Services & Fees (check box, add fee as appropriate)

- Return Receipt (hardcopy) \$
- Return Receipt (electronic) \$
- Certified Mail Restricted Delivery \$
- Adult Signature Required \$
- Adult Signature Restricted Delivery \$

Postmark
Here



Postage

\$

Total Postage and Fees

\$

Sent To

Micah Rodney Spears
Street and Apt. No., or PO Box No.
59 Marilyn Monroe Ct
City, State, ZIP+4®
Cecilia, KY 42724

PS Form 3800, April 2015 PSN 7530-02-000-9047

See Reverse for Instructions

7022 0410 0001 3131 1671

U.S. Postal Service™
CERTIFIED MAIL® RECEIPT
Domestic Mail Only

For delivery information, visit our website at www.usps.com®.

OFFICIAL USE

Certified Mail Fee

\$

Extra Services & Fees (check box, add fee as appropriate)

- Return Receipt (hardcopy) \$
- Return Receipt (electronic) \$
- Certified Mail Restricted Delivery \$
- Adult Signature Required \$
- Adult Signature Restricted Delivery \$

Postmark
Here



Postage

\$

Total Postage and Fees

\$

Sent To

Back Forty Rentals
Street and Apt. No., or PO Box No.
1404 Herseshoe Bend Road
City, State, ZIP+4®
Sunova, KY 42776

PS Form 3800, April 2015 PSN 7530-02-000-9047

See Reverse for Instructions

7022 1670 0001 5081 6125

U.S. Postal Service™
CERTIFIED MAIL® RECEIPT
Domestic Mail Only

For delivery information, visit our website at www.usps.com®.

OFFICIAL USE

Certified Mail Fee

\$

Extra Services & Fees (check box, add fee as appropriate)

- Return Receipt (hardcopy) \$
- Return Receipt (electronic) \$
- Certified Mail Restricted Delivery \$
- Adult Signature Required \$
- Adult Signature Restricted Delivery \$

Postmark
Here



Postage

\$

Total Postage and Fees

\$

Sent To

Douglas W & Donna K Reed
Street and Apt. No., or PO Box No.
297 Rodeo Drive
City, State, ZIP+4®
Cecilia, KY 42724

PS Form 3800, April 2015 PSN 7530-02-000-9047

See Reverse for Instructions

7022 1670 0001 5081 6125

U.S. Postal Service™
CERTIFIED MAIL® RECEIPT
Domestic Mail Only

For delivery information, visit our website at www.usps.com®.

OFFICIAL USE

Certified Mail Fee

\$

Extra Services & Fees (check box, add fee as appropriate)

- Return Receipt (hardcopy) \$
- Return Receipt (electronic) \$
- Certified Mail Restricted Delivery \$
- Adult Signature Required \$
- Adult Signature Restricted Delivery \$

Postmark
Here



Postage

\$

Total Postage and Fees

\$

Sent To

David R & Jacqueline S Felts
Street and Apt. No., or PO Box No.
999 Smith Mill Road
City, State, ZIP+4®
Cecilia, KY 42724

PS Form 3800, April 2015 PSN 7530-02-000-9047

See Reverse for Instructions

7022 0410 0001 3131 1833

U.S. Postal Service™
CERTIFIED MAIL® RECEIPT

Domestic Mail Only

For delivery information, visit our website at www.usps.com®.

OFFICIAL USE

Certified Mail Fee	\$
Extra Services & Fees (check box, add fee as appropriate)	
<input type="checkbox"/> Return Receipt (hardcopy)	\$
<input type="checkbox"/> Return Receipt (electronic)	\$
<input type="checkbox"/> Certified Mail Restricted Delivery	\$
<input type="checkbox"/> Adult Signature Required	\$
<input type="checkbox"/> Adult Signature Restricted Delivery	\$
Postage	\$
Total Postage and Fees	\$
Sent To	Jesse & Anley Skiggs
Street and Apt. No., or PO Box No.	615 Rodeo Drive
City, State, ZIP+4®	Cecilia, KY 42724

PS Form 3800, April 2015 PSN 7530-02-000-9047 See Reverse for Instructions



7022 1670 0001 5081 6132

U.S. Postal Service™
CERTIFIED MAIL® RECEIPT

Domestic Mail Only

For delivery information, visit our website at www.usps.com®.

OFFICIAL USE

Certified Mail Fee	\$
Extra Services & Fees (check box, add fee as appropriate)	
<input type="checkbox"/> Return Receipt (hardcopy)	\$
<input type="checkbox"/> Return Receipt (electronic)	\$
<input type="checkbox"/> Certified Mail Restricted Delivery	\$
<input type="checkbox"/> Adult Signature Required	\$
<input type="checkbox"/> Adult Signature Restricted Delivery	\$
Postage	\$
Total Postage and Fees	\$
Sent To	Serimiah & Destani Willis
Street and Apt. No., or PO Box No.	611 Rodeo Drive
City, State, ZIP+4®	Cecilia, KY 42724

PS Form 3800, April 2015 PSN 7530-02-000-9047 See Reverse for Instructions



7022 0410 0001 3131 1949

U.S. Postal Service™
CERTIFIED MAIL® RECEIPT

Domestic Mail Only

For delivery information, visit our website at www.usps.com®.

OFFICIAL USE

Certified Mail Fee	\$
Extra Services & Fees (check box, add fee as appropriate)	
<input type="checkbox"/> Return Receipt (hardcopy)	\$
<input type="checkbox"/> Return Receipt (electronic)	\$
<input type="checkbox"/> Certified Mail Restricted Delivery	\$
<input type="checkbox"/> Adult Signature Required	\$
<input type="checkbox"/> Adult Signature Restricted Delivery	\$
Postage	\$
Total Postage and Fees	\$
Sent To	Andrew J kutcher
Street and Apt. No., or PO Box No.	5934 Leitchfield Loop
City, State, ZIP+4®	Cecilia, KY 42724

PS Form 3800, April 2015 PSN 7530-02-000-9047 See Reverse for Instructions



7022 0410 0001 3131 1840

U.S. Postal Service™
CERTIFIED MAIL® RECEIPT

Domestic Mail Only

For delivery information, visit our website at www.usps.com®.

OFFICIAL USE

Certified Mail Fee	\$
Extra Services & Fees (check box, add fee as appropriate)	
<input type="checkbox"/> Return Receipt (hardcopy)	\$
<input type="checkbox"/> Return Receipt (electronic)	\$
<input type="checkbox"/> Certified Mail Restricted Delivery	\$
<input type="checkbox"/> Adult Signature Required	\$
<input type="checkbox"/> Adult Signature Restricted Delivery	\$
Postage	\$
Total Postage and Fees	\$
Sent To	Rebekah Heedy
Street and Apt. No., or PO Box No.	616 Rodeo Drive
City, State, ZIP+4®	Cecilia, KY 42724

PS Form 3800, April 2015 PSN 7530-02-000-9047 See Reverse for Instructions



7022 0410 0001 3131 1925

U.S. Postal Service™
CERTIFIED MAIL® RECEIPT
Domestic Mail Only

For delivery information, visit our website at www.usps.com®.

OFFICIAL USE

Certified Mail Fee

\$

Extra Services & Fees (check box, add fee as appropriate)

- Return Receipt (hardcopy) \$
- Return Receipt (electronic) \$
- Certified Mail Restricted Delivery \$
- Adult Signature Required \$
- Adult Signature Restricted Delivery \$

Postage

\$

Total Postage and Fees

\$

Sent To

Theresa K Preston

Street and Apt. No., or PO Box No.

5894 Leitchfield Loop

City, State, ZIP+4®

Cecilia, KY 42724

PS Form 3800, April 2015 PSN 7530-02-000-9047

See Reverse for Instructions



7022 0410 0001 3131 1932

U.S. Postal Service™
CERTIFIED MAIL® RECEIPT
Domestic Mail Only

For delivery information, visit our website at www.usps.com®.

OFFICIAL USE

Certified Mail Fee

\$

Extra Services & Fees (check box, add fee as appropriate)

- Return Receipt (hardcopy) \$
- Return Receipt (electronic) \$
- Certified Mail Restricted Delivery \$
- Adult Signature Required \$
- Adult Signature Restricted Delivery \$

Postage

\$

Total Postage and Fees

\$

Sent To

Scott M & Michelle L Bryant

Street and Apt. No., or PO Box No.

5916 Leitchfield Road

City, State, ZIP+4®

Cecilia, KY 42724

PS Form 3800, April 2015 PSN 7530-02-000-9047

See Reverse for Instructions

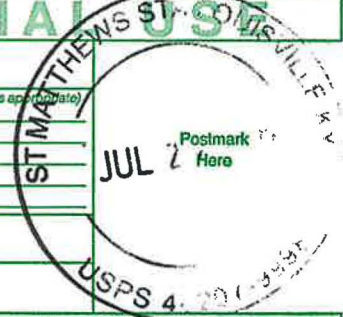

7022 0410 0001 3131 1901

U.S. Postal Service™
CERTIFIED MAIL® RECEIPT
Domestic Mail Only

For delivery information, visit our website at www.usps.com®.

OFFICIAL USE

Certified Mail Fee

\$

Extra Services & Fees (check box, add fee as appropriate)

- Return Receipt (hardcopy) \$
- Return Receipt (electronic) \$
- Certified Mail Restricted Delivery \$
- Adult Signature Required \$
- Adult Signature Restricted Delivery \$

Postage

\$

Total Postage and Fees

\$

Sent To

Tavi Joann Revocable Living Trust

Street and Apt. No., or PO Box No.

212 B Harmony Way

City, State, ZIP+4®

Elizabethan, KY 42701

PS Form 3800, April 2015 PSN 7530-02-000-9047

See Reverse for Instructions



7022 0410 0001 3131 1918

U.S. Postal Service™
CERTIFIED MAIL® RECEIPT
Domestic Mail Only

For delivery information, visit our website at www.usps.com®.

OFFICIAL USE

Certified Mail Fee

\$

Extra Services & Fees (check box, add fee as appropriate)

- Return Receipt (hardcopy) \$
- Return Receipt (electronic) \$
- Certified Mail Restricted Delivery \$
- Adult Signature Required \$
- Adult Signature Restricted Delivery \$

Postage

\$

Total Postage and Fees

\$

Sent To

Joshua T & Cynthia M Jewell

Street and Apt. No., or PO Box No.

5878 Leitchfield Road

City, State, ZIP+4®

Cecilia, KY 42724

PS Form 3800, April 2015 PSN 7530-02-000-9047

See Reverse for Instructions



7022 1670 0001 5081 6101

U.S. Postal Service™
CERTIFIED MAIL® RECEIPT
Domestic Mail Only

For delivery information, visit our website at www.usps.com®.

OFFICIAL USE

Certified Mail Fee
\$

Extra Services & Fees (check box, add fee as appropriate)

Return Receipt (hardcopy) \$

Return Receipt (electronic) \$

Certified Mail Restricted Delivery \$

Adult Signature Required \$

Adult Signature Restricted Delivery \$

Postage
\$

Total Postage and Fees
\$

Sent To
Street and Apt. No., or PO Box No.
City, State, ZIP+4®

PS Form 3800, April 2015 PSN 7530-02-000-9047 See Reverse for Instructions

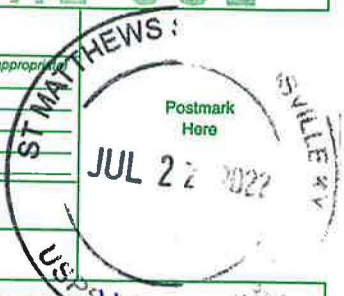

Wildcat Properties LLC
 643 Bates Road
 Elizabethtown, KY 42701

7022 1670 0001 5081 6095

U.S. Postal Service™
CERTIFIED MAIL® RECEIPT
Domestic Mail Only

For delivery information, visit our website at www.usps.com®.

OFFICIAL USE

Certified Mail Fee
\$

Extra Services & Fees (check box, add fee as appropriate)

Return Receipt (hardcopy) \$

Return Receipt (electronic) \$

Certified Mail Restricted Delivery \$

Adult Signature Required \$

Adult Signature Restricted Delivery \$

Postage
\$

Total Postage and Fees
\$

Sent To
Street and Apt. No., or PO Box No.
City, State, ZIP+4®

PS Form 3800, April 2015 PSN 7530-02-000-9047 See Reverse for Instructions



Douglas H & Sharmin H Lush
 524 St Ambrose Ch Ln
 Cecilia, KY 42724

7022 1670 0001 5081 6293

U.S. Postal Service™
CERTIFIED MAIL® RECEIPT
Domestic Mail Only

For delivery information, visit our website at www.usps.com®.

OFFICIAL USE

Certified Mail Fee
\$

Extra Services & Fees (check box, add fee as appropriate)

Return Receipt (hardcopy) \$

Return Receipt (electronic) \$

Certified Mail Restricted Delivery \$

Adult Signature Required \$

Adult Signature Restricted Delivery \$

Postage
\$

Total Postage and Fees
\$

Sent To
Street and Apt. No., or PO Box No.
City, State, ZIP+4®

PS Form 3800, April 2015 PSN 7530-02-000-9047 See Reverse for Instructions



Jimmy N Waugh
 6541 Leitchfield Road
 Cecilia, KY 42724

7022 0410 0001 3131 1857

U.S. Postal Service™
CERTIFIED MAIL® RECEIPT
Domestic Mail Only

For delivery information, visit our website at www.usps.com®.

OFFICIAL USE

Certified Mail Fee
\$

Extra Services & Fees (check box, add fee as appropriate)

Return Receipt (hardcopy) \$

Return Receipt (electronic) \$

Certified Mail Restricted Delivery \$

Adult Signature Required \$

Adult Signature Restricted Delivery \$

Postage
\$

Total Postage and Fees
\$

Sent To
Street and Apt. No., or PO Box No.
City, State, ZIP+4®

PS Form 3800, April 2015 PSN 7530-02-000-9047 See Reverse for Instructions



Jason L & Lia C Cline
 173 W Dana Reed Boulevard
 Cecilia, KY 42724

7022 1670 0001 5081 6309

U.S. Postal Service™
CERTIFIED MAIL® RECEIPT
Domestic Mail Only

For delivery information, visit our website at www.usps.com®.

OFFICIAL USE

Certified Mail Fee

\$

Extra Services & Fees (check box, add fee as appropriate)

- Return Receipt (hardcopy) \$
- Return Receipt (electronic) \$
- Certified Mail Restricted Delivery \$
- Adult Signature Required \$
- Adult Signature Restricted Delivery \$

Postage

\$

Total Postage and Fees

\$

Sent To

David L & Clarissa G Yates
Street and Apt. No., or PO Box No.
191 Lewis Lane
City, State, ZIP+4®
Cecilia, KY 40204

PS Form 3800, April 2015 PSN 7530-02-000-9047

See Reverse for Instructions



7022 1670 0001 5081 6194

U.S. Postal Service™
CERTIFIED MAIL® RECEIPT
Domestic Mail Only

For delivery information, visit our website at www.usps.com®.

OFFICIAL USE

Certified Mail Fee

\$

Extra Services & Fees (check box, add fee as appropriate)

- Return Receipt (hardcopy) \$
- Return Receipt (electronic) \$
- Certified Mail Restricted Delivery \$
- Adult Signature Required \$
- Adult Signature Restricted Delivery \$

Postage

\$

Total Postage and Fees

\$

Sent To

Jackie A Gardner
Street and Apt. No., or PO Box No.
610 Rodeo Drive
City, State, ZIP+4®
Cecilia, KY 40204

PS Form 3800, April 2015 PSN 7530-02-000-9047

See Reverse for Instructions



7022 1670 0001 5081 6323

U.S. Postal Service™
CERTIFIED MAIL® RECEIPT
Domestic Mail Only

For delivery information, visit our website at www.usps.com®.

OFFICIAL USE

Certified Mail Fee

\$

Extra Services & Fees (check box, add fee as appropriate)

- Return Receipt (hardcopy) \$
- Return Receipt (electronic) \$
- Certified Mail Restricted Delivery \$
- Adult Signature Required \$
- Adult Signature Restricted Delivery \$

Postage

\$

Total Postage and Fees

\$

Sent To

Clayton L & Geraldine H Grey
Street and Apt. No., or PO Box No.
656 S Black Branch Road
City, State, ZIP+4®
Cecilia, KY 40204

PS Form 3800, April 2015 PSN 7530-02-000-9047

See Reverse for Instructions



7022 1670 0001 5081 6316

U.S. Postal Service™
CERTIFIED MAIL® RECEIPT
Domestic Mail Only

For delivery information, visit our website at www.usps.com®.

OFFICIAL USE

Certified Mail Fee

\$

Extra Services & Fees (check box, add fee as appropriate)

- Return Receipt (hardcopy) \$
- Return Receipt (electronic) \$
- Certified Mail Restricted Delivery \$
- Adult Signature Required \$
- Adult Signature Restricted Delivery \$

Postage

\$

Total Postage and Fees

\$

Sent To

Donald R & Linda R Sexton
Street and Apt. No., or PO Box No.
434 S Black Branch Road
City, State, ZIP+4®
Cecilia, KY 40204

PS Form 3800, April 2015 PSN 7530-02-000-9047

See Reverse for Instructions

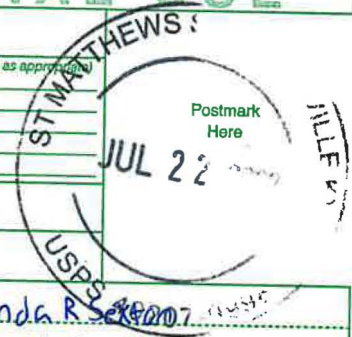

7022 0410 0001 3131 1888

U.S. Postal Service™
CERTIFIED MAIL® RECEIPT
Domestic Mail Only

For delivery information, visit our website at www.usps.com™.

OFFICIAL USE

Certified Mail Fee

\$

- Return Receipt (hardcopy) \$
- Return Receipt (electronic) \$
- Certified Mail Restricted Delivery \$
- Adult Signature Required \$
- Adult Signature Restricted Delivery \$

Postage

\$

Total Postage and Fees

\$

Sent To Sean C & Rena Hall

Street and Apt. No., or PO Box No. 5781 Leitchfield Road

City, State, ZIP+4® Cecilia, KY 40224

PS Form 3800, April 2015 PSN 7530-02-000-9047 See Reverse for Instructions



7022 0410 0001 3131 1895

U.S. Postal Service™
CERTIFIED MAIL® RECEIPT
Domestic Mail Only

For delivery information, visit our website at www.usps.com™.

OFFICIAL USE

Certified Mail Fee

\$

- Return Receipt (hardcopy) \$
- Return Receipt (electronic) \$
- Certified Mail Restricted Delivery \$
- Adult Signature Required \$
- Adult Signature Restricted Delivery \$

Postage

\$

Total Postage and Fees

\$

Sent To Randall & Deborah Goodman

Street and Apt. No., or PO Box No. 5854 Leitchfield Road

City, State, ZIP+4® Cecilia, KY 40224

PS Form 3800, April 2015 PSN 7530-02-000-9047 See Reverse for Instructions



7022 1670 0001 5081 6156

U.S. Postal Service™
CERTIFIED MAIL® RECEIPT
Domestic Mail Only

For delivery information, visit our website at www.usps.com™.

OFFICIAL USE

Certified Mail Fee

\$

- Return Receipt (hardcopy) \$
- Return Receipt (electronic) \$
- Certified Mail Restricted Delivery \$
- Adult Signature Required \$
- Adult Signature Restricted Delivery \$

Postage

\$

Total Postage and Fees

\$

Sent To Attn: Jacob Riggs

Street and Apt. No., or PO Box No. KYTC District 4, 634 E Dixie Avenue

City, State, ZIP+4® Elizabethtown, KY 40201

PS Form 3800, April 2015 PSN 7530-02-000-9047 See Reverse for Instructions



7022 1670 0001 5081 6149

U.S. Postal Service™
CERTIFIED MAIL® RECEIPT
Domestic Mail Only

For delivery information, visit our website at www.usps.com™.

OFFICIAL USE

Certified Mail Fee

\$

- Return Receipt (hardcopy) \$
- Return Receipt (electronic) \$
- Certified Mail Restricted Delivery \$
- Adult Signature Required \$
- Adult Signature Restricted Delivery \$

Postage

\$

Total Postage and Fees

\$

Sent To KYTC Central Office

Street and Apt. No., or PO Box No. 200 Merc Street

City, State, ZIP+4® Frankfort, KY 40602

PS Form 3800, April 2015 PSN 7530-02-000-9047 See Reverse for Instructions



7022 1670 0001 5081 6170

**U.S. Postal Service™
CERTIFIED MAIL® RECEIPT**
Domestic Mail Only

For delivery information, visit our website at www.usps.com®.

OFFICIAL USE

Certified Mail Fee
\$

Extra Services & Fees (check box, add fee as appropriate)

<input type="checkbox"/> Return Receipt (hardcopy)	\$
<input type="checkbox"/> Return Receipt (electronic)	\$
<input type="checkbox"/> Certified Mail Restricted Delivery	\$
<input type="checkbox"/> Adult Signature Required	\$
<input type="checkbox"/> Adult Signature Restricted Delivery	\$

Postage
\$

Total Postage and Fees
\$

Sent To Buchanan Property Group LLC 37-4
Street and Apt. No., or PO Box No. 801 Lakeside Drive
City, State, ZIP+4® Elizabethtown, KY 42701

PS Form 3800, April 2015 PSN 7530-02-000-9047 See Reverse for Instructions

Postmark Here
JUL 22 2022
ST MATTHEWS ST
USPS 4020

7022 1670 0001 5081 6168

**U.S. Postal Service™
CERTIFIED MAIL® RECEIPT**
Domestic Mail Only

For delivery information, visit our website at www.usps.com®.

OFFICIAL USE

Certified Mail Fee
\$

Extra Services & Fees (check box, add fee as appropriate)

<input type="checkbox"/> Return Receipt (hardcopy)	\$
<input type="checkbox"/> Return Receipt (electronic)	\$
<input type="checkbox"/> Certified Mail Restricted Delivery	\$
<input type="checkbox"/> Adult Signature Required	\$
<input type="checkbox"/> Adult Signature Restricted Delivery	\$

Postage
\$

Total Postage and Fees
\$

Sent To Dr Christopher and Dana Nell Knight 1-4900
Street and Apt. No., or PO Box No. 281 Timber Lane
City, State, ZIP+4® Elizabethtown, KY 42701

PS Form 3800, April 2015 PSN 7530-02-000-9047 See Reverse for Instructions

Postmark Here
JUL 22 2022
ST MATTHEWS ST
USPS 4020

7022 0410 0001 3131 1956

**U.S. Postal Service™
CERTIFIED MAIL® RECEIPT**
Domestic Mail Only

For delivery information, visit our website at www.usps.com®.

OFFICIAL USE

Certified Mail Fee
\$

Extra Services & Fees (check box, add fee as appropriate)

<input type="checkbox"/> Return Receipt (hardcopy)	\$
<input type="checkbox"/> Return Receipt (electronic)	\$
<input type="checkbox"/> Certified Mail Restricted Delivery	\$
<input type="checkbox"/> Adult Signature Required	\$
<input type="checkbox"/> Adult Signature Restricted Delivery	\$

Postage
\$

Total Postage and Fees
\$

Sent To Clayton & Geraldine Grey
Street and Apt. No., or PO Box No. 670 S Black Branch Road
City, State, ZIP+4® Cecilia, KY 42724

PS Form 3800, April 2015 PSN 7530-02-000-9047 See Reverse for Instructions

Postmark Here
JUL 22 2022
ST MATTHEWS ST
USPS 4020

7022 1670 0001 5081 6187

**U.S. Postal Service™
CERTIFIED MAIL® RECEIPT**
Domestic Mail Only

For delivery information, visit our website at www.usps.com®.

OFFICIAL USE

Certified Mail Fee
\$

Extra Services & Fees (check box, add fee as appropriate)

<input type="checkbox"/> Return Receipt (hardcopy)	\$
<input type="checkbox"/> Return Receipt (electronic)	\$
<input type="checkbox"/> Certified Mail Restricted Delivery	\$
<input type="checkbox"/> Adult Signature Required	\$
<input type="checkbox"/> Adult Signature Restricted Delivery	\$

Postage
\$

Total Postage and Fees
\$

Sent To Reba Buchanan
Street and Apt. No., or PO Box No. 801 Lakeside Drive
City, State, ZIP+4® Elizabethtown, KY 42701

PS Form 3800, April 2015 PSN 7530-02-000-9047 See Reverse for Instructions

Postmark Here
JUL 22 2022
ST MATTHEWS ST
USPS 4020

7022 0410 0001 3131 1970

U.S. Postal Service™
CERTIFIED MAIL® RECEIPT
Domestic Mail Only

For delivery information, visit our website at www.usps.com™.

OFFICIAL USE

Certified Mail Fee
\$

Extra Services & Fees (check box, add fee as appropriate)

<input type="checkbox"/> Return Receipt (hardcopy)	\$
<input type="checkbox"/> Return Receipt (electronic)	\$
<input type="checkbox"/> Certified Mail Restricted Delivery	\$
<input type="checkbox"/> Adult Signature Required	\$
<input type="checkbox"/> Adult Signature Restricted Delivery	\$

Postage
\$

Total Postage and Fees
\$

Sent To **Davis George A Living Trust**
 Street and Apt. No., or PO Box No. **161 Lombardy Drive**
 City, State, ZIP+4® **Cecilia, Ky 42724**

PS Form 3800, April 2015 PSN 7530-02-000-9047 See Reverse for Instructions

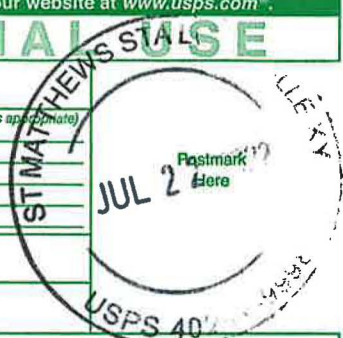

7022 0410 0001 3131 1967

U.S. Postal Service™
CERTIFIED MAIL® RECEIPT
Domestic Mail Only

For delivery information, visit our website at www.usps.com™.

OFFICIAL USE

Certified Mail Fee
\$

Extra Services & Fees (check box, add fee as appropriate)

<input type="checkbox"/> Return Receipt (hardcopy)	\$
<input type="checkbox"/> Return Receipt (electronic)	\$
<input type="checkbox"/> Certified Mail Restricted Delivery	\$
<input type="checkbox"/> Adult Signature Required	\$
<input type="checkbox"/> Adult Signature Restricted Delivery	\$

Postage
\$

Total Postage and Fees
\$

Sent To **Justin & Shannon Childers**
 Street and Apt. No., or PO Box No. **7372 Leitchfield Road**
 City, State, ZIP+4® **Cecilia, Ky 42724**

PS Form 3800, April 2015 PSN 7530-02-000-9047 See Reverse for Instructions

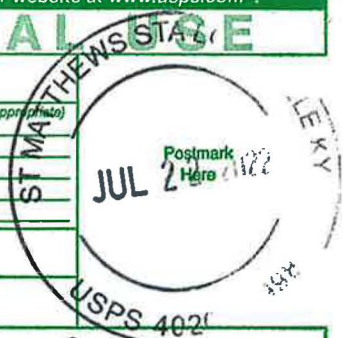

7022 0410 0001 3131 1994

U.S. Postal Service™
CERTIFIED MAIL® RECEIPT
Domestic Mail Only

For delivery information, visit our website at www.usps.com™.

OFFICIAL USE

Certified Mail Fee
\$

Extra Services & Fees (check box, add fee as appropriate)

<input type="checkbox"/> Return Receipt (hardcopy)	\$
<input type="checkbox"/> Return Receipt (electronic)	\$
<input type="checkbox"/> Certified Mail Restricted Delivery	\$
<input type="checkbox"/> Adult Signature Required	\$
<input type="checkbox"/> Adult Signature Restricted Delivery	\$

Postage
\$

Total Postage and Fees
\$

Sent To **James Kevin & Charlotte Ann Clark**
 Street and Apt. No., or PO Box No. **7865 Leitchfield Road**
 City, State, ZIP+4® **Cecilia, Ky 42724**

PS Form 3800, April 2015 PSN 7530-02-000-9047 See Reverse for Instructions



7022 0410 0001 3131 1967

U.S. Postal Service™
CERTIFIED MAIL® RECEIPT
Domestic Mail Only

For delivery information, visit our website at www.usps.com™.

OFFICIAL USE

Certified Mail Fee
\$

Extra Services & Fees (check box, add fee as appropriate)

<input type="checkbox"/> Return Receipt (hardcopy)	\$
<input type="checkbox"/> Return Receipt (electronic)	\$
<input type="checkbox"/> Certified Mail Restricted Delivery	\$
<input type="checkbox"/> Adult Signature Required	\$
<input type="checkbox"/> Adult Signature Restricted Delivery	\$

Postage
\$

Total Postage and Fees
\$

Sent To **Doris Claiborne LLC**
 Street and Apt. No., or PO Box No. **935 Lakeview Parkway, Suite 190**
 City, State, ZIP+4® **Vernon Hills, IL 60061**

PS Form 3800, April 2015 PSN 7530-02-000-9047 See Reverse for Instructions



7022 0410 0001 3131 2021

U.S. Postal Service™ CERTIFIED MAIL® RECEIPT

Domestic Mail Only

For delivery information, visit our website at www.usps.com™.

OFFICIAL USE

Certified Mail Fee

\$

Extra Services & Fees (check box, add fee as appropriate)

- Return Receipt (hardcopy) \$
- Return Receipt (electronic) \$
- Certified Mail Restricted Delivery \$
- Adult Signature Required \$
- Adult Signature Restricted Delivery \$

Postage

\$

Total Postage and Fees

\$

Sent To

Clarence Rogers

413 Reynolds Road

Glendale, KY 42740

PS Form 3800, April 2015 PSN 7530-02-000-9047 See Reverse for Instructions

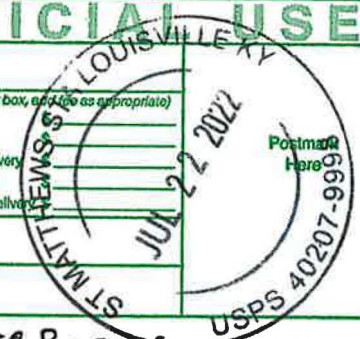

7022 0410 0001 3131 2007

U.S. Postal Service™ CERTIFIED MAIL® RECEIPT

Domestic Mail Only

For delivery information, visit our website at www.usps.com™.

OFFICIAL USE

Certified Mail Fee

\$

Extra Services & Fees (check box, add fee as appropriate)

- Return Receipt (hardcopy) \$
- Return Receipt (electronic) \$
- Certified Mail Restricted Delivery \$
- Adult Signature Required \$
- Adult Signature Restricted Delivery \$

Postage

\$

Total Postage and Fees

\$

Sent To

J David Simcoe

262 S Long Grave Road

Glendale, KY 42740

PS Form 3800, April 2015 PSN 7530-02-000-9047 See Reverse for Instructions



7022 0410 0001 3131 2030

U.S. Postal Service™ CERTIFIED MAIL® RECEIPT

Domestic Mail Only

For delivery information, visit our website at www.usps.com™.

OFFICIAL USE

Certified Mail Fee

\$

Extra Services & Fees (check box, add fee as appropriate)

- Return Receipt (hardcopy) \$
- Return Receipt (electronic) \$
- Certified Mail Restricted Delivery \$
- Adult Signature Required \$
- Adult Signature Restricted Delivery \$

Postage

\$

Total Postage and Fees

\$

Sent To

Donald Buchanan

801 Lakeside Drive

Elizabethtown, KY 42701

PS Form 3800, April 2015 PSN 7530-02-000-9047 See Reverse for Instructions



7022 0410 0001 3131 2014

U.S. Postal Service™ CERTIFIED MAIL® RECEIPT

Domestic Mail Only

For delivery information, visit our website at www.usps.com™.

OFFICIAL USE

Certified Mail Fee

\$

Extra Services & Fees (check box, add fee as appropriate)

- Return Receipt (hardcopy) \$
- Return Receipt (electronic) \$
- Certified Mail Restricted Delivery \$
- Adult Signature Required \$
- Adult Signature Restricted Delivery \$

Postage

\$

Total Postage and Fees

\$

Sent To

Steven C & Ann D Rogers

315 Reynolds Road

Glendale, KY 42740

PS Form 3800, April 2015 PSN 7530-02-000-9047 See Reverse for Instructions



U.S. Postal Service™
CERTIFIED MAIL® RECEIPT
Domestic Mail Only

For delivery information, visit our website at: www.usps.com

OFFICIAL USE

Certified Mail Fee	\$
Extra Services & Fees (check box, add fee as appropriate)	
<input type="checkbox"/> Return Receipt (hardcopy)	\$
<input type="checkbox"/> Return Receipt (electronic)	\$
<input type="checkbox"/> Certified Mail Restricted Delivery	\$
<input type="checkbox"/> Adult Signature Required	\$
<input type="checkbox"/> Adult Signature Restricted Delivery	\$

Postage	\$
Total Postage and Fees	\$

Sent To	Jacob Waltz
Street and Apt. No., or PO Box No.	5230 Glendale Hodgenville Road W
City, State, ZIP+4®	Glendale, KY 40740

PS Form 3800, April 2015 PSN 7530-02-000-9047 See Reverse for Instructions

7022 0410 0001 3131 0140 0140 2007



Exhibit B-2

Kentucky Classified Network

TO PLACE AN AD
CALL 270-765-3862 or EMAIL:
kyclass@thenewsenterprise.com

0100 ANNOUNCEMENTS

BANKRUPTCY, DIVORCE, WORK INJURIES.
Kelley Law Offices, E'town, 769-2368.
Divorce, Fee: Uncontested no children \$300, children \$350. **CLIENT PAYS COURT COST AND EXPENSES.**
A debt relief agency. This is an advertisement.

CASH PAID FOR:
Used Furniture, Yard Sale Leftovers, Home Contents, Estates, Free Pick up for aluminum, tin cans, electronics scrap. **Call 270-735-7812.**

FOR SALE
SWEET CORN, TOMATOES, POTATOES, GREEN BEANS & CUCUMBERS
Plus all other produce is ready.

8:30 am to 7 pm
Mon thru Sat.
Closed Sundays.
Ben Miller.
716 Upton Rd.
Upton Ky.

FARM-FRESH FOODS
HOME GROWN GARDEN FRESH PRODUCE.
Tomatoes, Green Beans, Onions, Squash, Red Beets, Cucumbers, Cabbage, Potatoes. Available First of July
Sweet Corn, Peppers, Cantaloupes, Watermelons.
John Miller
955 Upton Road.
Upton, KY 42784.

LOOKING FOR
A. B. McDonough son of Sibylla M. McDonough. Call 817-561-2698.

LOOKING TO BUY
4-wheelers, dirt bikes, mowers & zero turns, golf carts & tractors. **Call or text 270-766-9940**

TAKING DONATIONS for a small shed 10x10 or 10x12, Cooker, stoves, refrigerators, washers, dryers, jazzy chairs for the church. Working condition. Please call 270-763-7956

White female 75 years old looking for a man around my age for companionship. 270-862-9280

Find it!
IN THE CLASSIFIEDS!

0150 GARAGE / ESTATE SALES

3 Day Estate/ Garage Sale in Rineyville, KY
58 Fletcher Court Rineyville, KY 40162
Starting Friday July 21st at 9:00am to 6:00pm
Saturday July 22nd 9am-5:00pm
Sunday July 23rd 12:00pm-5:00pm
Everything must go. Men's clothing (Size L shirts/jackets/hoodies, 36-38 Pants, Size 10 shoes), Women's Clothing (Petite Sizes, Size 5 shoes)
Like new wicker Patio Furniture Set
Numerous small appliances (blenders, pressure cooker, steamers, toaster oven, grills, crock pots, waffle maker, etc)
Women's Bicycle Christmas Décor
Home Decor (signs, pictures, paintings, trinkets, etc)
Cook Books
Pot, pans, dishes, cups
Blankets, sheets, misc bedding
Variety of Light Bulbs, cleaners, home maintenance items
Curio Cabinet
CDs, DVDs
Antiques (Dishware, china, telephone line insulators, whiskey trolley collection, etc)
Too much to list, and adding more as we go through the house.
All very nice items for sale, priced to move.

YARD SALE
AS SEEN IN THE NEWS-ENTERPRISE
Schedule your Yard Sale ad for 3 Days!

Receive 10 lines of text (approx. 35-40 words), a Banner, Border and Yard Sale Sign* for **less than \$30.**

Must submit information by 11 am the day prior to publication date.

Call: 270-765-3862
Email: KyClass@thenewsenterprise.com
Or stop by in person: The News-Enterprise 200 Sycamore Street Suite 134 Elizabethtown, KY
Lobby hours 10 am-2 pm
**signs available at the office*

0200 EMPLOYMENT

KONSEI USA, INC
Leading supplier in manufacturer of automotive parts and still growing!

NOW HIRING!
Machine Operators Full Time
\$13/hour to start
12 hour shifts
Will return to 8 hour shifts as soon as we have the manpower!
Employee benefits for Full-Time

APPLY AT OUR OFFICE
401 Commerce Pkwy.,
Hodgenville, KY 42748
(270) 358-0145
Ext. 1212

HIRING NUTRITION SERVICE WORKERS for Elizabethtown Independent Schools District Nutrition Services Department.

•Substitute and full time positions are currently available.
•Little or no experience is required to join our team.
•We are looking for dedicated workers who are willing to learn and have a passion for feeding nutritious meals to hungry students!
•Multiple positions are available with opportunities for advancement.
•Work while your child is in school.

• Paid Holidays, Sick/Personal Leave, Summers Off ... lots of Benefits!

How to apply?
Visit www.ETOWN.K12.KY.US or call Marty Adams at 270-766-1231.

0300 PETS
FRENCH BULL DOGS-
2 females, 4 males, up to date on shots. \$2,500 each. Call 270-218-0544.

NEED A CAREER? GET ONE HERE.
The Classifieds.

0400 FARM

FARM Fresh
HOME GROWN PRODUCE FOR SALE.
Sweet Corn
\$3.00 a dozen or \$15.00 a bushel.
Tomatoes, Green Beans, Potatoes, Cucumbers, Candy Onions.
Harvey Miller
1076 Upton Road
Upton, KY 42784

0500 MERCHANDISE
JOYCE'S FURNITURE

"Quality Furniture Low Prices."

Lots to choose from:
• Sofa sets.
• Reclining furniture
• Sectionals.
• Bedroom Suites - Cherry & Oak.
• Mattress Sets - all sizes
• A variety of Curios - Oak & Cherry.
• Tables & Chairs - formal & country.
• End, Coffee & Sofa Tables
...and more

Come See Us Before You Buy. You Will Be Glad You Did.

Layaway - Finance Available

Joyce's Furniture
14 miles from E'town
H.W. 62 West
270-862-3641
Closed Sun & Mon
Open 10:30a-6p (EST)

HOYER LIFT, jazzy chair, water softener, stackable washer & dryer, portable washer & dryer, hospital bed, 6ft dresser with mirror, stove, treadmill, 14 cubic refrigerator, side by side refrigerator, washer & dryer. 4 chairs. 270-763-7956.

0500 MERCHANDISE

WINDOWS
Custom Built Vinyl Windows for any home.
Call Wagler Windows now for in home free estimate.
270-932-1644

0600 REAL ESTATE FOR RENT
All real estate advertising in the newspaper is subject to the Fair Housing Act which makes it illegal to advertise "any preference, limitation or discrimination based on race, color, religion, sex, handicap, familial status or national origin or an intention to make any such preference, limitation or discrimination." Familial status includes children under the age of 18 living with parents or legal custodians, pregnant women and people securing custody of children under 18. This newspaper will not knowingly accept any advertising for real estate which is in violation of the law. Our readers are hereby informed that all dwellings advertised in this newspaper are available on an equal opportunity basis. To complain of discrimination, call HUD toll-free at 1-800-669-9777. The toll free telephone number for the hearing impaired is 1-800-927-9275.

HERITAGE MANOR At North Miles and Colonial Dr. Duplex community. 2 & 3 bedroom w/1 & 2 baths. Stove, refrigerator, dishwasher, laundry hookup. Cathedral ceilings, skylights, fireplaces, ceiling fan, walk in closets. Children welcome. Your own private yard and driveway. Call 270-765-3770 or 502-708-2550.

0700 REAL ESTATE FOR SALE
FOR SALE
479 acres, 3655 Lower Colesburg Road. 3 B/R Brick home, open ground and lots of woods.
The Land Store
Call Tim Aulbach at 270-766-8263

0700 REAL ESTATE FOR SALE

Kentucky Land Co. of Irvington
1-866-865-5263 or (270) 547-4222
498 S. Woodlawn St., Owner Financing with **No Penalty** for early pay off!!

Irvington, KY
Very nice corner Lot .72 acres. OK for Stick Built or Modular with Block Foundation. City Water, City Sewer. Asking \$23,900.

5 Acre Lot
off of 86 on Jesse Priest Lane. Completely Wooded. Electric available. Asking \$37,900.

Several Nice Lots
on Dairy lane off of Bewleyville-Rosetta Rd

Hudson, KY
Very nice 5 acre tracts located on Cedar Creek Lane. Electric available. Asking \$39,900 each.

3.75 Acre Lot
on Hwy 86. Has County water and blacktop road. Asking \$34,900.

Westview, KY
2 lots total of 1.4 acres. Rough River waterfront. Located on The Cliffs Lane. Asking \$45,900.

Falls of Rough
3 very nice lots on Tick Ridge Road. Lots are wooded. Great for camping and Building site. No restrictions. Water & Electric at road.

www.KY-landco.com

SUMMIT CREEK
City lots with sewer on Hutcherson Ln. off Patriot Pkwy \$42,500 & up. Agent Owned.

BECKLEYWOODS
New Glendale Rd. \$33,500 & up. Agent Owned.

The Land Store
(270) 737-0399

0900 LEGALS

Fort Knox proposes to demolish Crittenberger School, Building 4553, in order to construct a new Child Development Center (CDC) on the site. Fort Knox has been unsuccessful in finding a new tenant or a reuse for the property since 2017. Constructed in 1952, it was determined Eligible for listing in the National Register of Historic Places in 2013. Fort Knox, in consultation with Kentucky State Historic Preservation Officer (SHPO), has determined that this undertaking will result in an adverse effect to the historic building. In accordance with the National Historic Preservation Act (36 C.F.R. part 800) Fort Knox is inviting interested members of the public to comment on the proposed undertaking and mitigation measures. Documents describing the proposed demolition project and the means by which Fort Knox proposes to mitigate the adverse effects are available for public review at the (1) Barr Library, 62 Spearhead Division Avenue, Fort Knox, KY 40121; (2) Hardin County Public Library, 100 Jim Owens Drive, Elizabethtown, KY 42701 and (3) the Meade County Public Library, 996 Old Ekron Road, Brandenburg, KY 40108 for 30 days following the initial publication of this notice, July 18, 2022. Public comments regarding the project can be addressed to E. Nicole Mills, AMIM-KNP-E, 125 6th AVE STE 224, Fort Knox, KY 40121, email: elizabeth.n.mills4.civ@army.mil.

0900 LEGALS

NEED A CAREER? GET ONE HERE.
The Classifieds.

0900 LEGALS

NOTICE
Stonefield Solar, LLC, is proposing to develop, construct and operate an approximately 120-megawatt solar merchant electric generating facility and nonregulated transmission line to be located in Hardin County, Kentucky. The proposed solar project will be situated on approximately 1,030 acres along US Highway 62 south of Elizabethtown and will consist of photovoltaic panels and their associated racking systems, inverters, collection system, transmission line, project substation, and other project equipment. The project will connect to a substation to be constructed on site. The substation will connect to the existing electric grid via an approximately 13,523-foot nonregulated transmission line to be constructed between the project footprint and the existing Central Hardin Substation located on Pritchard Parkway in Elizabethtown. More information on the project can be found at www.stonefieldsolar.com. Stonefield Solar, LLC (Case No. 2022-00011), is required to file an application with the Kentucky Electric Generation and Transmission Siting Board ("Board") to obtain a certificate for the construction of the proposed merchant electric generating facility and nonregulated electric transmission line. This filing will occur in the coming weeks. This proposed construction is subject to approval by the Board, which can be reached at P.O. Box 615, 211 Sower Boulevard, Frankfort, Kentucky 40602-0615, or via phone at (502) 564-3940. A person who wishes to become a party to a proceeding before the board may, by written motion filed no later than thirty (30) days after the application has been submitted, request leave to intervene. A party may, upon written motion filed no later than thirty (30) days after an application has been filed, request the board to schedule an evidentiary hearing at the offices of the Public Service Commission, 211 Sower Boulevard, Frankfort, Kentucky, 40602. A request for a local public hearing or local public information meeting shall be made by at least three (3) interested persons who reside in the county or municipal corporation in which the merchant electric generation facility is proposed to be located. The request shall be made in writing and shall be filed within thirty (30) days following the filing of a completed application. If you have questions, please contact Stonefield Solar at info@stonefieldsolar.com or at (270) 681-5720.

0900 LEGALS

HOME
Is Where the HEART IS

0900 LEGALS

It's in the Classifieds!

jobs find your career
Technology Careers
General Careers
Education Careers

Exhibit B-3



October 28, 2021

[NAME]

[Address]

[CITY, STATE, ZIP]

Dear Name,

I am writing to inform you of a proposed photovoltaic solar energy project of up to 120-megawatts near the Vulcan Quarry site along US-62 located near Cecilia, KY. The project is being developed by Stonefield Solar, LLC, an affiliate of Candela Renewables. We have been working to develop the project for over a year, and in the first quarter of 2022 we intend to formally submit our application to the Kentucky Electric Generation and Transmission Siting Board for review and approval to begin construction.

The state review process will take six months or more, and construction would begin no earlier than fourth quarter of 2022. We are also in discussion with the Hardin County Planning and Development Commission staff and the Hardin County Engineer regarding the County's site development requirements related to stormwater management, vegetation management, site access, property line setbacks, viewshed impacts, and other considerations critical to developing a project that can be a good neighbor.

Candela Renewables is one of the most experienced utility-scale solar project development companies in the United States. The company was founded in 2018 by a team of people who have worked together for decades developing coal, gas, and most recently solar projects across the country. We have worked on dozens of solar projects that are operating successfully today across the U.S., with combined generation of over 4,000 megawatts of power – equivalent to about 1.6 times as much power as the Niagara Dam hydroelectric power project is capable of producing. More information is available on our project website at www.stonefieldsolar.com if you are interested in learning more about us.

We are pleased to invite you to a Public Information Meeting to be held on Thursday, November 11, 2021, from 6 to 8 p.m. in the Community Hall at Central Kentucky Community Foundation located at 200 Jim Owen Drive, Elizabethtown, KY 42701.

If you'd like to contact me directly, you can call me at (270) 681-0415 or email me at info@stonefieldsolar.com. I look forward to seeing you at the meeting or discussing with you soon via phone or email.

Thank You,

Rick Ferrera
Project Manager

Landowner	Address	Parcel ID
BUCHANAN DONALD G -ETAL-	801 LAKSESIDE DR ELIZABETHTOWN KY 42701	148-00-00-011
ROGERS CLARENCE M -ETAL-	413 REYNOLDS RD413 REYNOLDS RD GLENDALE KY 42740	148-00-00-012.01 & 148-00-00-012
WALTZ JACOB	5230 GLENDALE HODGENVILLE RD W GLENDALE KY 42740	149-00-00-003
ROGERS STEVEN C	315 REYNOLDS RD GLENDALE KY 42740	149-00-00-004
SIMCOE J DAVID	262 S LONG GROVE RD GLENDALE KY 42740-0000	149-00-00-001
TAYLOR SUSAN G, Estate of	714 FOXCROFT TRL MARLETTA GA 30067-5508	148-00-00-013
DORIS CLAIBORNE LLC &	935 LAKEVIEW PKWY SUITE 190 VERNON HILLS IL 60061	126-00-00-021
DAVIS GEORGE A LIVING TRUST	161 LOMBARDY DR CECILIA KY 42724-0000	148-00-00-008
CHILDERS JUSTIN & SHANNON	7372 LEITCHFIELD RD CECILIA KY 42724	148-00-00-009
GREY CLAYTON & GERALDINE &	670 S BLACK BRANCH RD CECILIA KY 42724	148-00-00-002
KUTCHER ANDREW J	5934 LEITCHFIELD LOOP CECILIA KY 42724-9530	168-00-00-007
BRYANT SCOTT M & MICHELLE L	5916 LEITCHFIELD RD CECILIA KY 42724	168-00-00-008
PRESTON THERESA K	5894 LEITCHFIELD LOOP CECILIA KY 42724	168-00-00-009
JEWELL JOSHUA T & CYNTHIA M	5878 LEITCHFIELD RD CECILIA KY 42724	168-00-00-010
TAUL JOANN REVOCABLE LIVING TRUST	212B HARMONY WAY ELIZABETHTOWN KY 42701	168-20-00-035.02
GOODMAN RANDALL & DEBROAH	5854 LEITCHFIELD RD CECILIA KY 42724-0000	168-00-00-011
HALL SEAN C & RENA	5781 LEITCHFIELD RD CECILIA KY 42724	169-00-00-001.01
BACK FORTY RENTALS LLC	1404 HORSESHOE BEND RD SONORA KY 42776	169-00-02-075
SPEARS MICAH RODNEY &	59 MARILYN MONROE CT CECILIA KY 42724	169-00-02-076
CLINE JASON L & LIA C	173 W DONNA REED BLVD CECILIA KY 42724	169-00-02-077
HENSLEY TIMOTHY M & STEPHANIE A	616 RODEO DR CECILIA KY 42724	169-00-02-111
BOONE REGINA	615 RODEO DR CECILIA KY 42724	169-00-02-112
EARLE ELIJAH E	611 RODEO DR CECILIA KY 42724	169-00-02-113
CONRAD TERRY WAYNE & AMANDA RENE	297 RODEO DR CECILIA KY 42724	169-00-02-121
FELTS DAVID R & JACQUELINE J	999 SMITH MILL RD CECILIA KY 42724	169-00-00-002.01
ROGERS STEVEN C & ANN D	315 REYNOLDS RD GLENDALE KY 42740	169-00-00-009.02
WILDCAT PROPERTIES LLC	643 BATES RD ELIZABETHTOWN KY 42701	168-20-00-036.02 & 168-20-00-037
LUSH DOUGLAS H 7 SHARMIN H	524 ST AMBROSE CH LN CECILIA KY 42724	147-00-00-044.01
GRAY CLAYTON L & GERALDINE H	656 S BLACK BRANCH RD CECILIA KY 42724	148-00-00-001
SEXTON DONALD R & LINDA R	434 S BLACK BRANCH RD CECILIA KY 42724	147-00-00-028 & 147-00-00-028.04
YATES DAVID L & CLARISSA G	194 LEWIS LN CECILIA KY 42724	147-00-00-028.01
WAUGH, Jimmy N	6541 Leitchfield Rd, Cecilia, KY 42724	148-00-00-006
KYTC District 4 Attn: Jacob Riggs	634 E Dixie Ave, Elizabethtown, KY 42701	KYTC District 4 Attn: Jacob Riggs
KYTC Central Office	200 Mero St, Frankfort, KY 40622	KYTC Central Office
Gardner, Jackie	610 Rodeo DR CECILIA KY 42724	169-00-02-110
Roy Easter	1420 Hunters Lane Radcliff KY 40160	Magistrate District 1
Doug Goodman	P.O. Box 304 Radcliff, KY 40159	Magistrate District 2
Lisa Williams	73 Whispering Pine Way, Elizabethtown, KY 42701	Magistrate District 3
Fred Clem Jr.	365 Timber Ln. Elizabethtown, KY 42701	Magistrate District 4
Bill Wiseman	315 Churchhill Ct. Elizabethtown, KY 42701	Magistrate District 5
E.G. Thompson	672 Beasley Blvd, Elizabethtown, KY 42701	Magistrate District 6
Ronnie Goodman	475 Meadowview Ln. Cecilia, KY 42724	Magistrate District 7
Garry King	1004 Muirfield Ct. Vine Grove, KY 40175	Magistrate District 8

10509 Timberwood Circle
Suite 100
Louisville, KY 40223

FIRST-CLASS



PITNEY BOWES
US POSTAGE
02 1P \$ 000.53⁰
0001219868 OCT 28 2021
MAILED FROM ZIP CODE 40223

DAVID & CLARISSA YATES
194 LEWIS LN.
CECILIA, KY 42724

10509 Timberwood Circle
Suite 100
Louisville, KY 40223

FIRST-CLASS



PITNEY BOWES
US POSTAGE
02 1P \$ 000.53⁰
0001219868 OCT 28 2021
MAILED FROM ZIP CODE 40223

KYTC DISTRICT 4, ATTN: JACOB RIGGS
634 E. DIXIE AVE.
ELIZABETHTOWN, KY 42701

10509 Timberwood Circle
Suite 100
Louisville, KY 40223

FIRST-CLASS



PITNEY BOWES
US POSTAGE
02 1P \$ 000.53⁰
0001219868 OCT 28 2021
MAILED FROM ZIP CODE 40223

JACKIE GARDNER
610 RODEO DR.
CECILIA, KY 42724

10509 Timberwood Circle
Suite 100
Louisville, KY 40223

FIRST-CLASS



PITNEY BOWES
US POSTAGE
02 1P \$ 000.53⁰
0001219868 OCT 28 2021
MAILED FROM ZIP CODE 40223

KYTC CENTRAL OFFICE
200 MERO ST.
FRANKFORT, KY 40622

10509 Timberwood Circle
Suite 100
Louisville, KY 40223



DOUGLAS LUSH
524 ST AMBROSE CH LN.
CECILIA, KY 42724

10509 Timberwood Circle
Suite 100
Louisville, KY 40223



CLAYTON & GERALDINE GREY
656 S BLACK BRANCH RD.
CECILIA, KY 42724

10509 Timberwood Circle
Suite 100
Louisville, KY 40223



DONALD & LINDA SEXTON
434 S BLACK BRANCH RD.
CECILIA, KY 42724

10509 Timberwood Circle
Suite 100
Louisville, KY 40223



JIMMY WAUGH
6541 LEITCHFIELD RD.
CECILIA, KY 42724

10509 Timberwood Circle
Suite 100
Louisville, KY 40223



ELIJAH EARLE
611 RODEO DR.
CECILIA, KY 42724

10509 Timberwood Circle
Suite 100
Louisville, KY 40223



STEVEN & ANN ROGERS
315 REYNOLDS RD.
GLENDALE, KY 42740

10509 Timberwood Circle
Suite 100
Louisville, KY 40223



DAVID & JACQUELINE FELTS
999 SMITH MILL RD.
CECILIA, KY 42724

10509 Timberwood Circle
Suite 100
Louisville, KY 40223



WILDCAT PROPERTIES, LLC
643 BATES RD.
ELIZABETHTOWN, KY 42701

10509 Timberwood Circle
Suite 100
Louisville, KY 40223



MICAH RODNEY SPEARS
59 MARILYN MONROE CT.
CECILIA, KY 42724

10509 Timberwood Circle
Suite 100
Louisville, KY 40223



TIMOTHY & STEPHANIE HENSLEY
616 RODEO DR.
CECILIA, KY 42724

10509 Timberwood Circle
Suite 100
Louisville, KY 40223



TERRY & AMANDA CONRAD
297 RODEO DR.
CECILIA, KY 42724

10509 Timberwood Circle
Suite 100
Louisville, KY 40223



REGINA BOONE
615 RODEO DR.
CECILIA, KY 42724

10509 Timberwood Circle
Suite 100
Louisville, KY 40223



JASON & LIA CLINE
173 W DONNA REED BLVD.
CECILIA, KY 42724

10509 Timberwood Circle
Suite 100
Louisville, KY 40223



BACK FORTY RENTALS LLC
1404 HORSESHOE BEND RD.
SONORA, KY 42776

10509 Timberwood Circle
Suite 100
Louisville, KY 40223



SEAN & RENA HALL
5781 LEITCHFIELD RD.
CECILIA, KY 42724

10509 Timberwood Circle
Suite 100
Louisville, KY 40223



JOANN TAUL REVOCABLE LIVING TRUST
212B HARMONY WAY
ELIZABETHTOWN, KY 42701

10509 Timberwood Circle
Suite 100
Louisville, KY 40223



SCOTT & MICHELLE BRYANT
5916 LEITCHFIELD RD.
CECILIA, KY 42724

10509 Timberwood Circle
Suite 100
Louisville, KY 40223



RANDALL & DEBORAN GOODMAN
5854 LEITCHFIELD RD.
CECILIA, KY 42724

10509 Timberwood Circle
Suite 100
Louisville, KY 40223



JOSHUA & CYNTHIA JEWELL
5878 LEITCHFIELD RD.
CECILIA, KY 42724

10509 Timberwood Circle
Suite 100
Louisville, KY 40223



THERESA K. PRESTON
5894 LEITCHFIELD LOOP
CECILIA, KY 42724

10509 Timberwood Circle
Suite 100
Louisville, KY 40223

FIRST-CLASS



US POSTAGE
02 1P **\$ 000.53⁰**
0001219868 OCT 28 2021
MAILED FROM ZIP CODE 40223

CLAYTON & GERALDINE GREY
670 S BLACK BRANCH RD.
CECILIA, KY 42724

10509 Timberwood Circle
Suite 100
Louisville, KY 40223

FIRST-CLASS



US POSTAGE
02 1P **\$ 000.53⁰**
0001219868 OCT 28 2021
MAILED FROM ZIP CODE 40223

DORIS CLAIBORNE, LLC
935 LAKEVIEW PKWY SUITE 190
VERNON HILLS, IL 60061

10509 Timberwood Circle
Suite 100
Louisville, KY 40223

FIRST-CLASS



US POSTAGE
02 1P **\$ 000.53⁰**
0001219868 OCT 28 2021
MAILED FROM ZIP CODE 40223

GEORGE A. DAVIS LIVING TRUST
161 LOMBARDY DR.
CECILIA, KY 42724

10509 Timberwood Circle
Suite 100
Louisville, KY 40223

FIRST-CLASS



US POSTAGE
02 1P **\$ 000.53⁰**
0001219868 OCT 28 2021
MAILED FROM ZIP CODE 40223

DAVID J. SIMCOE
262 S LONG GROVE RD.
GLENDALE, KY 42740

10509 Timberwood Circle
Suite 100
Louisville, KY 40223



DONALD BUCHANAN, ET AL
801 LAKESIDE DR.
ELIZABETHTOWN, KY 42701

10509 Timberwood Circle
Suite 100
Louisville, KY 40223



CLARENCE ROGERS, ET AL
413 REYNOLDS RD.
GLENDALE, KY 42740

10509 Timberwood Circle
Suite 100
Louisville, KY 40223



STEVEN C. ROGERS
315 REYNOLDS RD.
GLENDALE, KY 42740

10509 Timberwood Circle
Suite 100
Louisville, KY 40223



JACOB WALTZ
5230 GLENDALE HODGENVILLE RD. W
GLENDALE, KY 42740

10509 Timberwood Circle
Suite 100
Louisville, KY 40223



ANDREW J. KUTCHER
5934 LEITCHFIELD LOOP
CECILIA, KY 42724

10509 Timberwood Circle
Suite 100
Louisville, KY 40223



ESTATE OF SUSAN G. TAYLOR
714 FOXCROFT TRL.
MARIETTA, GA 30067

10509 Timberwood Circle
Suite 100
Louisville, KY 40223



JUSTIN & SHANNON CHILDERS
7372 LEITCHFIELD RD.
CECILIA, KY 42724

10509 Timberwood Circle
Suite 100
Louisville, KY 40223



Magistrate District 1
Roy Easter
1420 Hunters Lane
Radcliff, KY 40160

10509 Timberwood Circle
Suite 100
Louisville, KY 40223



Magistrate District 2
Doug Goodman
P.O. Box 304
Radcliff, KY 40159

10509 Timberwood Circle
Suite 100
Louisville, KY 40223



Magistrate District 3
Lisa Williams
73 Whispering Pine Way
Elizabethtown, KY 42701

10509 Timberwood Circle
Suite 100
Louisville, KY 40223



Magistrate District 4
Fred Clem, Jr.
365 Timber Lane
Elizabethtown, KY 42701

10509 Timberwood Circle
Suite 100
Louisville, KY 40223

FIRST-CLASS



Magistrate District 8
Garry King
1004 Muirfield Court
Vine Grove, KY 40175

10509 Timberwood Circle
Suite 100
Louisville, KY 40223

FIRST-CLASS



Magistrate District 7
Ronnie Goodman
475 Meadowview Lane
Cecilia, KY 42724

10509 Timberwood Circle
Suite 100
Louisville, KY 40223

FIRST-CLASS



Magistrate District 6
E.G. Thompson
672 Beasley Boulevard
Elizabethtown, KY 42701

10509 Timberwood Circle
Suite 100
Louisville, KY 40223

FIRST-CLASS



Magistrate District 5
Bill Wiseman
315 Churchill Court
Elizabethtown, KY 42701

Exhibit B-4

0900 LEGALS

0900 LEGALS

0900 LEGALS

0900 LEGALS

PUBLIC NOTICE
STONEFIELD SOLAR PROJECT

Stonefield Solar, LLC is proposing to develop and construct an approximately 120-megawatt photovoltaic solar electric generating facility to be located near the Vulcan Materials Quarry along U.S. Highway 62 in Hardin County, KY. The public is invited to learn more about the Project through the Project website and a Public Information Meeting. The website can be accessed at stonefieldsolar.com. Additionally, you may email questions to info@stonefieldsolar.com or call the Project hotline at (270) 681-0415. A Public Information Meeting will be held for the purpose of informing the public of the project being considered and receiving comment on it. The meeting will be held on Thursday, November 11, from 6PM to 8PM using an open house format. The meeting location will be the Community Hall at the Central Kentucky Community Foundation at 200 Jim Owen Drive in Elizabethtown. The Project website includes information about the size and location of the proposed Project and the anticipated economic impact. Those who prefer not to attend in person are welcome to review the Project website and to use the Project email address and phone number to provide feedback.

Public Notice

The City of Elizabethtown's Consolidated Annual Performance Evaluation Report (CAPER) as pertaining to the Community Development Block Grant 2020-21 program year is available for review. This report indicates the goals, objectives, and accomplishments of projects and activities that were funded throughout the year. The CAPER report will be submitted to the Department of Housing and Urban Development, Louisville District Office of Community Planning & Development for review and approval by November 18, 2021.

The public and/or any interested persons are invited to review and comment on the report. The comment period will run from November 1 thru November 15, 2021. This report will be available upon request at the City of Elizabethtown, Hardin County Public Library, and the Elizabethtown Housing Authority. All written comments should be addressed to: City of Elizabethtown, Department of Planning & Development, Attention: Melissa Harrell-Nepi, P.O. Box 550, Elizabethtown, KY 42702-0550.

CLASSIFIEDS



Easy-To-Find Bargains In The Classifieds

BUSINESSES & SERVICES DIRECTORY

Bailey's Masonry, Inc. Since 1980
BRICK • BLOCK • CHIMNEY CLEANING/INSPECTIONS
 1331 Battle Training Road, Elizabethtown
270-765-0969
 Fully Licensed & Insured - Bonded
 Billy J. Bailey, Owner - baileysmasonry@bbtel.com
Commercial - Industrial - Residential
TUCK POINTING • FOUNDATION REPAIRS • REPAIRING OF FIREPLACES AND CHIMNEYS



Custom Homes • Room Additions • Remodeling • Sun Rooms • Garages • Decks • Framing

Clayton Construction Company
 www.claytonconstruction.wisebuyingmall.com
WORK GUARANTEED • FREE ESTIMATES • WORK GUARANTEED • FREE ESTIMATES • WORK GUARANTEED
ALL YOUR CONSTRUCTION NEEDS • OVER 35 YEARS EXPERIENCE
 Owner
James Goldsmith
Home 270-737-3967
 Licensed & Insured Mobile 270-317-0572



NEED A HANDYMAN?

HouseDoctors®
 Handyman Professionals | Home Improvements

- Small Job Specialists
- Kitchen & Bath Remodeling
- Drywall Installation/Repair
- Doors Installation/Repair
- Weather Stripping
- Caulking
- Grab Bar Installation
- And Many More

270-506-3430
 www.housedoctors.com/handyman-hardincounty | hd541@housedoctors.com



All Around Aluminum

Over 40 Years Experience Fully Insured

- Vinyl Siding & Windows
- Continuous Gutters 5"x6"
- Leaf Free Leaf System
- Awning & Carports

Nathan Smallwood, Owner **270-877-5338 | 270-737-1036**



Vessels Roofing 2021 Readers' Choice Winner
 "The oldest roofing company in Hardin County!"

Specializing In Residential Roofing Projects
270-737-7464
 www.vesselsroofing.com

- Flashing Chimneys
- Skylites
- Dormers
- Gutters & Guards
- Vinyl Siding
- Soffit Work
- And More



Delivery Fee: \$75.00* | Pick Up Fee: \$75.00*
 Delivery fee, pickup fee, and 1st month's rent charge must be paid in advance. Loaded & unloading storage unit is offered.
 * Delivery & pick up fee applies to Hardin County. Call us at 270.352.0601 for rates outside of Hardin County.

Corvin's IN TOWN MOVING
 270-351-0601
 1-866-338-3045

Now Featuring Nationwide Moving

310 S. Dixie, Radcliff | 270.352.0601
 Mon. - Fri. 9 am - 6 pm & Sat. 9 am - 5 pm
 www.corvinofradcliff.com
 corvinmoving@gmail.com
NOW OFFERING ON SITE STORAGE



LI'L MANS SERVICES
 William or Bill Peak
 270-735-6219

Specializing in:
 Fire, Water & Smoke Damage • Odor Control
 Carpet Cleaning • Remodeling • Handyman Services
Carpet Cleaning - 3 Rooms \$80

Service Our Community for over 35 Years



RIGGS Construction & Home Improvement

Metal - Shingles - Siding - Remodeling
 Home Improvements - Windows & Doors
 All Types of Carpentry

270-360-0493 / 270-401-9899
 Building/Metal Distributor



Exhibit B-5

Candela Renewables, established in 2018, is the most accomplished team of utility-scale solar power plant developers in North America.

Members of the team have previously created over **7,000 MW** of contracted projects in final development, construction, or operation.

Candela currently holds a portfolio of **8,000 MW solar projects** together with **4,600 MW of energy storage** projects spanning 9 states in the U.S., of which 25 projects totaling 3,200 MW of solar and 2,000 MW of storage could be operational before 2026.

We are technology agnostic, flexible in our approach and well capitalized through our partnership with Naturgy Energy Group.



8,000 MW

SOLAR PROJECT PORTFOLIO

4,600 MW

ENERGY STORAGE PORTFOLIO

Selected Active Development Portfolio



Deep knowledge of energy markets enabling timely and cost-effective solar solutions for regulators, customers and consumers throughout the U.S.

CAISO
8 Projects | 2,150 MW

SOUTHWEST
5 Projects | 1,100 MW

ERCOT
3 Projects | 750 MW

SOUTHEAST
2 Projects | 150 MW

NYISO
4 Projects | 80 MW

PJM
5 Projects | 546 MW

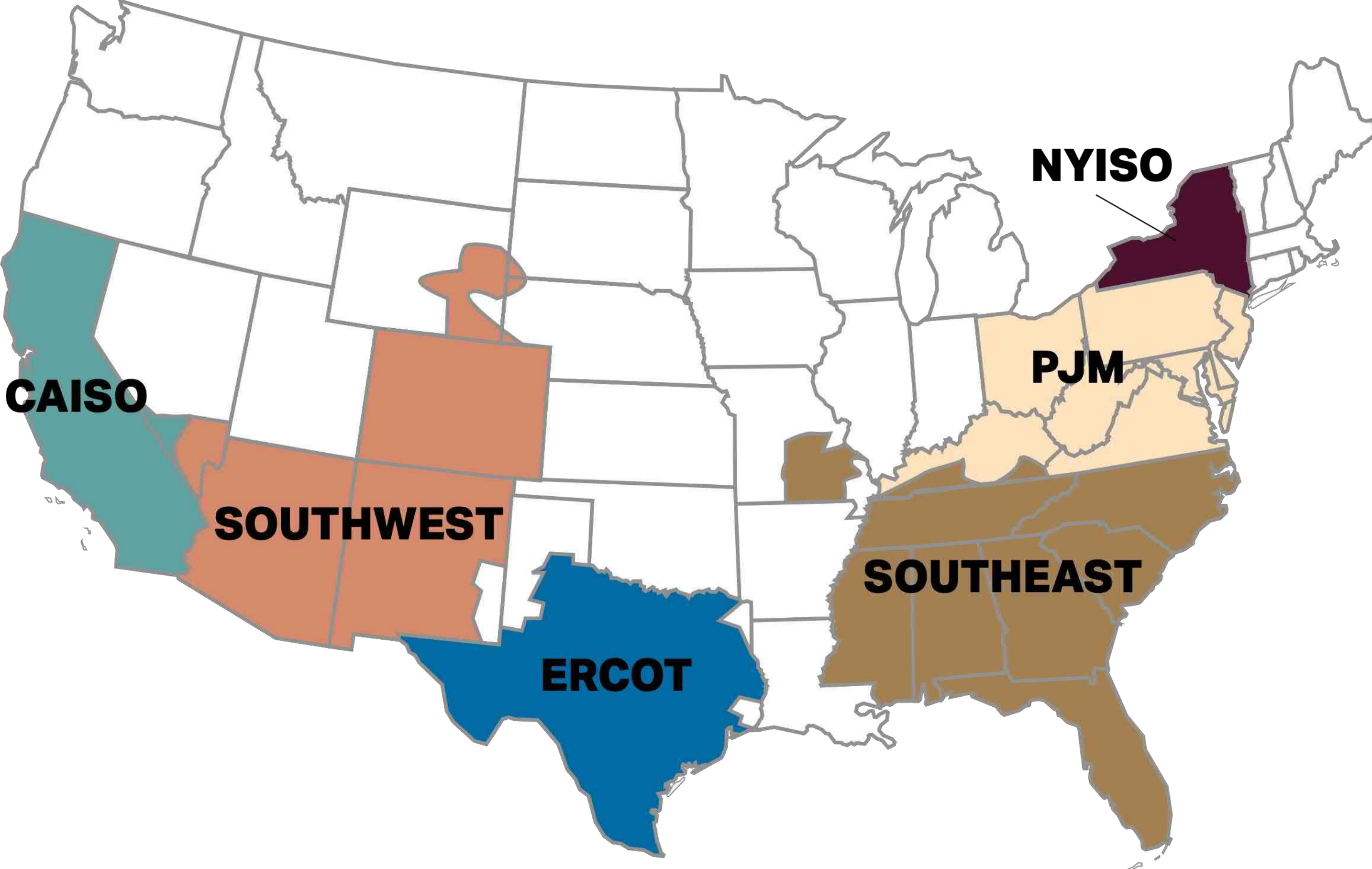

Permitting Site Plan

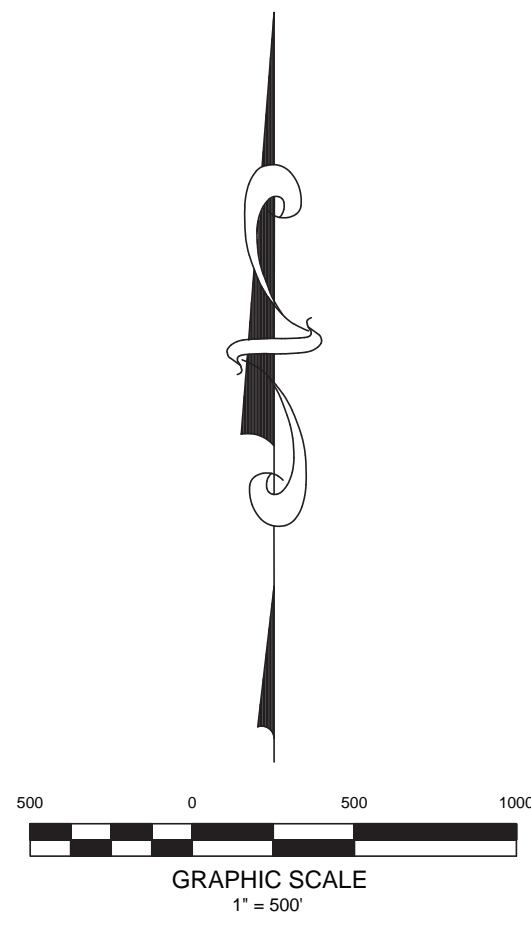
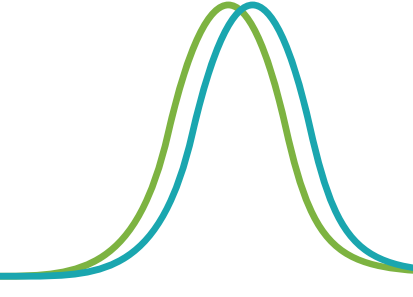

- Legend**
- PROJECT BOUNDARY
 - ADJOINER PROPERTY LINES
 - CENTERLINE CSX RAILROAD
 - VULCAN LEASE/PERMIT LINE
 - 100-YR FLOOD ZONE BOUNDARY PER FEMA FIRM MAPPING
 - POTENTIAL JURISDICTIONAL STREAMS (PER STANTEC)
 - POTENTIAL NON-JURISDICTIONAL STREAMS (PER STANTEC)
 - POTENTIAL JURISDICTIONAL WETLANDS (PER STANTEC)
 - POTENTIAL NON-JURISDICTIONAL WETLANDS (PER STANTEC)
 - SINKHOLES PER KENTUCKY GEOLOGICAL SURVEY DATA
 - ELECTRIC LINES
 - WATER LINES PER HARDIN COUNTY WATER DISTRICT NO.2
 - PROPOSED ELIZABETH TOWN WASTEWATER SYSTEM EXTENSION PER KENTUCKY INFRASTRUCTURE AUTHORITY - WATER RESOURCE INFORMATION SYSTEM MAPPING
 - SETBACK EXCLUSIONS (TO FENCE LINES) PER HARDIN COUNTY PLANNING AND ZONING - BASED ON I-2 REZONING
 - FRONT SETBACK (ROAD RIGHT-OF-WAY), RAILROAD R-O-W - 50'
 - SIDE SETBACK - 20' IF ADJOINING INDUSTRIAL ZONES, 100' IF ADJOINING RESIDENTIAL OR AGRICULTURAL ZONES
 - REAR SETBACK - 100' IF ADJOINING RESIDENTIAL OR AGRICULTURAL ZONES
- SITE FACILITIES**
- PV TRACKER ROWS
 - SECURITY FENCING
 - PROJECT SUBSTATION
 - PRIVATE GRAVEL ACCESS ROAD
 - INVERTER AND TRANSFORMER

GENERAL NOTES

AERIAL PHOTOGRAPHY PER ASSOCIATED ENGINEERS, INC. DRONE FLIGHT DATED JULY 23, 2021.
 DATUM: KY SOUTH NAD 83 COORDINATES.

PROPERTY INFORMATION PRESENTED ON THIS MAP AS PER ASSOCIATED ENGINEERS, INC. PROPERTY RESEARCH. THIS MAP DOES NOT DEPICT THE RESULTS OF AN ACTUAL BOUNDARY OR LEASE SURVEY AND SHOULD NOT BE USED FOR RECORDING OR LAND TRANSFER.

For Buried Line/Date Locations

 CALL 48 HOURS IN ADVANCE OF DIGGING.

PERMITTING SITE PLAN
 STONEFIELD SOLAR PROJECT
 HARDIN COUNTY, KENTUCKY

2740 NORTH MAIN ST. • MADISONVILLE, KY. 42431-9470
 PHONE: 270-821-7732 • FAX: 270-821-7789 • WWW.ASSOCIATEDENGINEERS.COM

REVISIONS:	DATE	PROJECT NO.	SCALE
		21-0088E	1" = 500'
			DRAWN BY
			JCC/DLM

Stonefield Solar Project Visual Simulation



Visual Renderings based on publicly available terrain data (LiDar), photographs taken by Stantec Consulting on August 25, 2021, and solar equipment specifications provided by Candela Renewables.

Photovoltaic Solar Farm

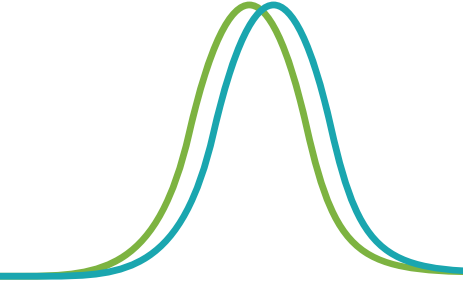

Modules

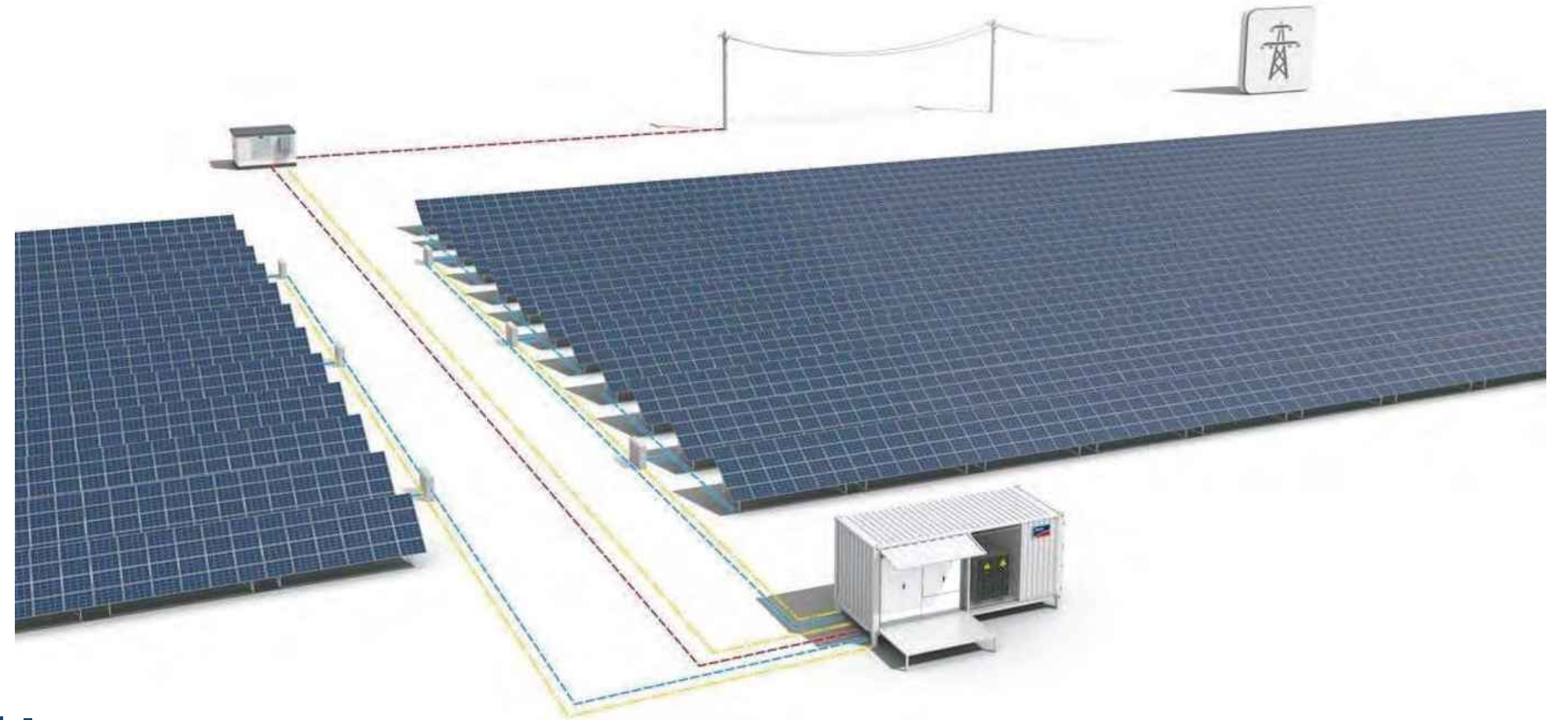
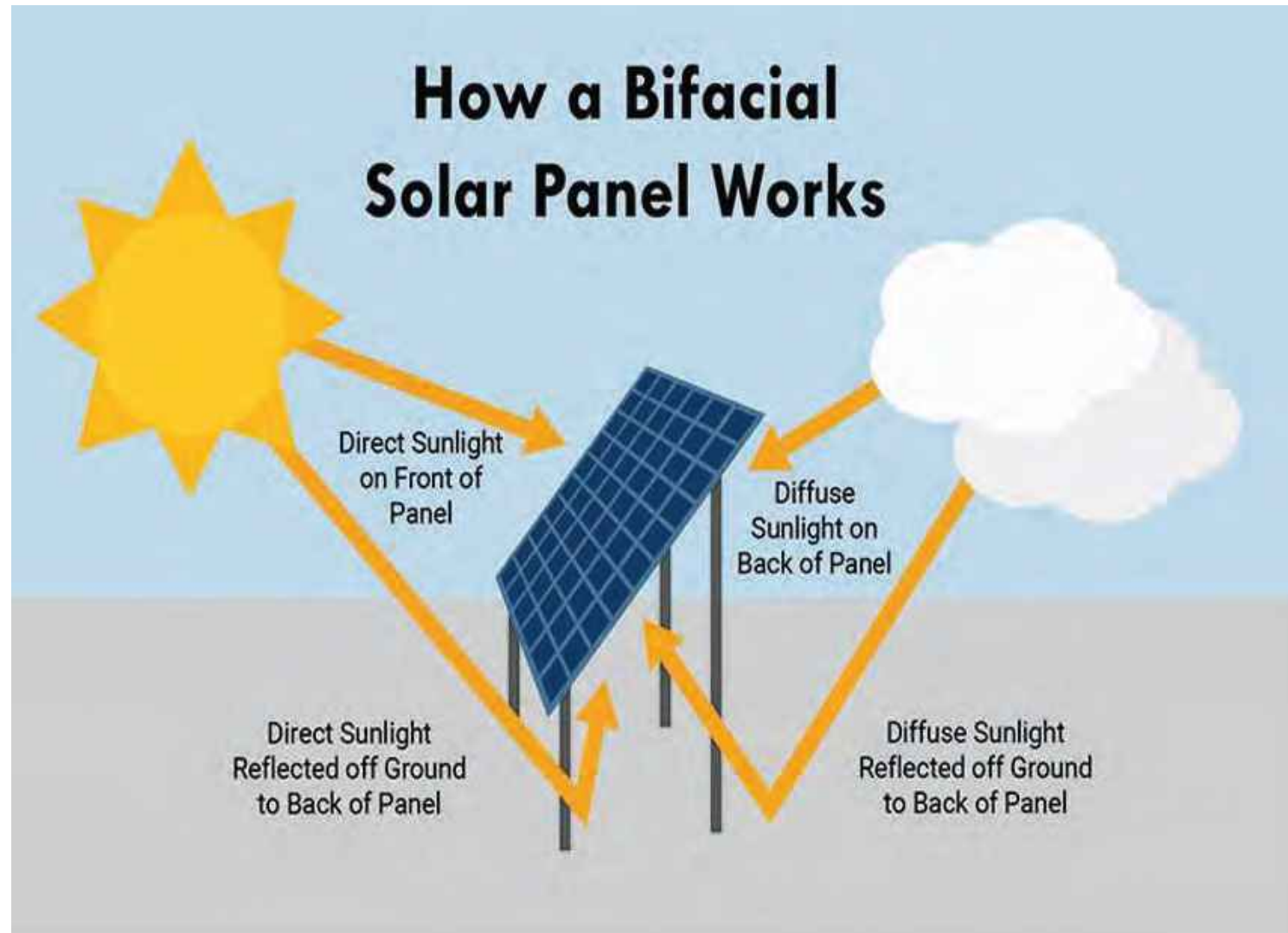

Tracker



Central Inverter



Project Substation



Bi-facial technology improves efficiency



Technology

Modules laid out in rows running north-south, with single-axis tracking technology rotating from east to west to follow the sun throughout the day.

Construction

A 120 MW solar farm is typically constructed over a period of 9 to 12 months, with an average of 250 construction jobs at a time. Activities include site prep and installation of components. Special attention will be paid to sinkholes, drain tiles, dust control and sensitive species.



Property Tax Benefits

Compared to current land use, Stonefield Solar is expected to generate over 24 times as much tax revenue for Hardin County during the first year of the project's life

Property Tax Revenue Generated by Current Land Use

1. < \$10,000 of tax revenue generated annually by properties involved in project

Year 1: < \$10,000

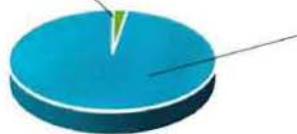

Total Over 40 Years:
< \$400,000

Property Tax Revenue Generated by Stonefield Solar Project

1. Real and tangible personal property taxes expected to generate \$240,000 in first year of project and \$5.7 million over life of project
2. Solar projects do not impose significant new financial obligations on county, so most new revenue will be available for use

Total Over 40 Years:
\$5,700,000

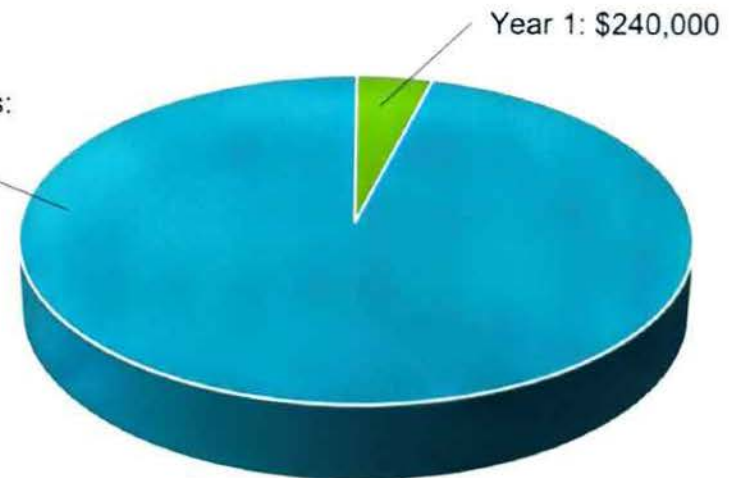

■ Year 1 ■ Total Over 40 Years

StoneField Solar Public Meeting November 11, 2021

Name	Phone	Address	Email
Tim + Anne Hall	270-765-9698	9822 New Glendale Rd Sonoma KY 42716	antihall@windstream.net
Doug Lush	270-862-4731	524 St. Ambrose Ch Ln Cecilia Ky	
Ken Anderson	270-862-4731		
Sean + Renee Hall	770-739-6748	5833 Leitchfield Loop Cecilia	
Connie Goff	270-769-8686	6435 N Long Grove Rd Cecilia	
Chuck Clark	270-234-4932	↓	
Tamara Taylor		5378 Ruckelshaus Rd Elizabethton	
Jean Felts	270-862-4568	999 Cecilia Smithmills Rd Cecilia	
Cheryl Thompson	270-270-347		
EMILY STROBACH	330-714-7298	KENTON	

Exhibit B-6

COMMONWEALTH OF KENTUCKY
BEFORE THE KENTUCKY STATE BOARD ON ELECTRIC GENERATION
AND TRANSMISSION SITING

In the Matter of:

ELECTRONIC APPLICATION OF)
STONEFIELD SOLAR, LLC FOR A)
CERTIFICATE OF CONSTRUCTION FOR) Case No. 2022-00011
AN APPROXIMATELY 120 MEGAWATT)
MERCHANT ELECTRIC SOLAR GENERATING)
FACILITY AND NONREGULATED)
TRANSMISSION LINE IN HARDIN COUNTY,)
KENTUCKY PURSUANT TO KRS 278.700)
ET SEQ. AND 807 KAR 5:110.)

Proof Of Service in Compliance with KRS 278.706(2)(h) and 278.714(2)(f)

Comes the Affiant, Aubree Muse, and hereby states as follows:

1. I am over the age of 18 and a resident of Kentucky.
2. On this day, August 19, 2022, I personally delivered electronic versions of the Stonefield Solar, LLC, Application for a construction certificate to construct a merchant solar electric generating facility and a non-regulated transmission line to the following individuals/locations:

County Judge-Executive Harry Berry
150 N. Provident Way, Suite 314
Elizabethtown, KY 42701
(270) 765-2350

Planning Commission Chairman Mark Hinton
150 N. Provident Way, Suite 225
Elizabethtown, KY 42701
(270) 769-5479

Date: August 19, 2022

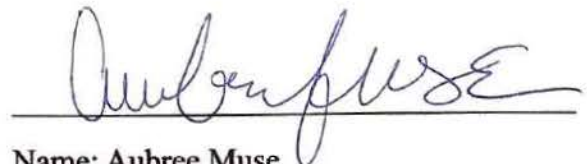

Name: Aubree Muse
Title: Development Analyst, Candela Renewables

(COMMONWEALTH OF KENTUCKY)

(COUNTY OF HARDIN)

Subscribed and sworn before me, I Maci Belfiore, a

Notary Public, in and for the County and State above, do hereby declare that the Affiant,

Audree Muse did appear personally before me

and furnish to me adequate identification of proving their identity and stated that

she (he/she) did sign this document of their own free will, on this the 19th day of

August, 2022.

(AFFIX SEAL)



Maci Belfiore

Notary Public

My Commission expires: 7.24.2025

EXHIBIT C

COMMONWEALTH OF KENTUCKY
BEFORE THE KENTUCKY STATE BOARD ON ELECTRIC GENERATION
AND TRANSMISSION SITING

In the Matter of:

ELECTRONIC APPLICATION OF)	
STONEFIELD SOLAR, LLC FOR A)	
CERTIFICATE OF CONSTRUCTION FOR)	
AN APPROXIMATELY 120 MEGAWATT)	Case No. 2022-00011
MERCHANT ELECTRIC SOLAR GENERATING)	
FACILITY AND NONREGULATED)	
TRANSMISSION LINE IN HARDIN COUNTY,)	
KENTUCKY PURSUANT TO KRS 278.700)	
AND 807 KAR 5:110.)	

Certification Required by KRS 278.706(2)(d)

Comes the Affiant, James F Cook, and hereby states as follows:

1. I am over the age of 18 and a resident of California.
2. I am the Vice President of Development of Candela Renewables, LLC, the contract development agent for Stonefield Solar, LLC.
3. I have conducted an inquiry into the facts contained in this Statement and have found them to be true to the best of my knowledge and belief.
4. I hereby certify that the proposed facility as planned and to be constructed in Hardin County, Kentucky will be in compliance with all local ordinances and regulations concerning noise control, and will be in compliance with any local planning and zoning ordinances.
5. I have been informed that the general setback requirements established by the Hardin County Planning and Zoning Commission for structures in a Heavy Industrial (I-2) zone are Minimum Front Yard Setback of 50 feet (40 feet for adjoining commercial zones); Minimum Side Yard Setback of 20 feet (40 feet for adjoining commercial zones, 100 feet for adjoining residential and agricultural zones); and Minimum Rear Yard Setback of 35 feet (40 feet for adjoining commercial zones, 100 feet for adjoining residential and agricultural zones).

Signed this 18th day of AUGUST, 2022.

Candela Renewables, LLC, contract
development agent for Stonefield Solar,
LLC

By: 
Name: James F Cook
Title: Vice President

A notary public or other officer completing this certificate
verifies only the identity of the individual who signed the
document to which this certificate is attached, and not the
truthfulness, accuracy, or validity of that document.

State of California
County of Santa Clara
Subscribed and sworn to (or affirmed) before me
on this 18th day of August, 2022
by JAMES F. COOK
proved to me on the basis of satisfactory evidence
to be the person(s) who appeared before me.

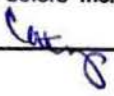
Signature: 

 **CATHY M. WONG**
COMM. #2403771
Notary Public - California
Santa Clara County
My Comm. Expires June 4, 2026

EXHIBIT D



Generation Interconnection
REVISED System Impact Study Report
for
Queue Project AF2-391
CENTRAL HARDIN 69 KV
72.0 MW Capacity / 120 MW Energy

January 2022

Table of Contents

1	Introduction.....	4
2	Preface.....	4
3	General.....	5
4	Point of Interconnection.....	6
5	Cost Summary.....	6
6	Transmission Owner Scope of Work.....	7
6.1	Attachment Facilities.....	7
6.2	Direct Connection Cost Estimate.....	7
6.3	Non-Direct Connection Cost Estimate.....	7
7	Interconnection Customer Requirements.....	8
8	Revenue Metering and SCADA Requirements.....	9
8.1	PJM Requirements.....	9
8.2	Meteorological Data Reporting Requirements.....	9
8.3	Interconnected Transmission Owner Requirements.....	9
9	Summer Peak Analysis.....	10
9.1	Generation Deliverability.....	10
9.2	Multiple Facility Contingency.....	10
9.3	Contribution to Previously Identified Overloads.....	12
9.4	Steady-State Voltage Requirements.....	14
9.5	Potential Congestion due to Local Energy Deliverability.....	14
9.6	System Reinforcements.....	20
9.7	Flow Gate Details.....	27
10	Light Load Analysis.....	37
10.1	Generation Deliverability.....	37
10.2	Multiple Facility Contingency.....	37
10.3	Contribution to Previously Identified Overloads.....	37
10.4	Steady-State Voltage Requirements.....	37
10.5	Potential Congestion due to Local Energy Deliverability.....	37
11	Short Circuit Analysis.....	38
12	Stability and Reactive Power.....	38
13	Affected Systems.....	38

13.1	TVA.....	38
13.2	MISO	38
13.3	LG&E.....	38
14	Attachment 1: One Line Diagram	39

1 Introduction

This System Impact Study has been prepared in accordance with the PJM Open Access Transmission Tariff, 205, as well as the System Impact Study Agreement between the Interconnection Customer (IC), and PJM Interconnection, LLC (PJM), Transmission Provider (TP). The Interconnected Transmission Owner (ITO) is EKPC.

2 Preface

The intent of the System Impact Study is to determine a plan, with approximate cost and construction time estimates, to connect the subject generation interconnection project to the PJM network at a location specified by the Interconnection Customer. As a requirement for interconnection, the Interconnection Customer may be responsible for the cost of constructing: Network Upgrades, which are facility additions, or upgrades to existing facilities, that are needed to maintain the reliability of the PJM system. All facilities required for interconnection of a generation interconnection project must be designed to meet the technical specifications (on PJM web site) for the appropriate transmission owner.

In some instances an Interconnection Customer may not be responsible for 100% of the identified network upgrade cost because other transmission network uses, e.g. another generation interconnection or merchant transmission upgrade, may also contribute to the need for the same network reinforcement. The possibility of sharing the reinforcement costs with other projects may be identified in the Feasibility Study, but the actual allocation will be deferred until the System Impact Study is performed.

The System Impact Study estimates do not include the feasibility, cost, or time required to obtain property rights and permits for construction of the required facilities. The project developer is responsible for the right of way, real estate, and construction permit issues. For properties currently owned by Transmission Owners, the costs may be included in the study.

The Interconnection Customer seeking to interconnect a wind or solar generation facility shall maintain meteorological data facilities as well as provide that meteorological data which is required per Schedule H to the Interconnection Service Agreement and Section 8 of Manual 14D.

An Interconnection Customer with a proposed new Customer Facility that has a Maximum Facility Output equal to or greater than 100 MW shall install and maintain, at its expense, phasor measurement units (PMUs). See Section 8.5.3 of Appendix 2 to the Interconnection Service Agreement as well as section 4.3 of PJM Manual 14D for additional information.

3 General

The Interconnection Customer (IC), has proposed a Solar generating facility located in Hardin County, Kentucky. The installed facilities will have a total capability of 120 MW with 72.0 MW of this output being recognized by PJM as Capacity.

The proposed in-service date for this project is June 15, 2023. This study does not imply a TO commitment to this in-service date.

Queue Number	AF2-391
Project Name	CENTRAL HARDIN 69 KV
State	Kentucky
County	Hardin
Transmission Owner	EKPC
MFO	120
MWE	120
MWC	72.0
Fuel	Solar
Basecase Study Year	2023

Any new service customers who can feasibly be commercially operable prior to June 1st of the basecase study year are required to request interim deliverability analysis.

4 Point of Interconnection

AF2-391 will interconnect with the EKPC transmission system at the Central Hardin 69kV substation.

5 Cost Summary

The AF2-391 project will be responsible for the following costs:

Description	Total Cost
Total Physical Interconnection Costs	\$910,000
Allocation towards System Network Upgrade Costs*	\$3,299,136**
Total Costs	\$4,209,136**

*As your project progresses through the study process and other projects modify their request or withdraw, then your cost allocation could change.

** Final LG&E Impacts and necessary LG&E system upgrade(s) will be determined once the LG&E affected system study is completed by LG&E.

The estimates provided in this report are preliminary in nature, as they were determined without the benefit of detailed engineering studies. Final estimates will require an on-site review and coordination to determine final construction requirements. In addition, Stability analysis will be completed during the Facilities Study stage. It is possible that a need for additional upgrades could be identified by these studies.

This cost excludes a Federal Income Tax Gross Up charges. This tax may or may not be charged based on whether this project meets the eligibility requirements of IRS Notice 2016-36, 2016-25 I.R.B. (6/20/2016). If at a future date it is determined that the Federal Income Tax Gross charge is required, the Transmission Owner shall be reimbursed by the Interconnection Customer for such taxes.

Note 1: PJM Open Access Transmission Tariff (OATT) section 217.3A outline cost allocation rules. The rules are further clarified in PJM Manual 14A Attachment B. The allocation of costs for a network upgrade will start with the first Queue project to cause the need for the upgrade. Later queue projects will receive cost allocation contingent on their contribution to the violation and are allocated to the queues that have not closed less than 5 years following the execution of the first Interconnection Service Agreement which identifies the need for this upgrade.

Note 2: For customers with System Reinforcements listed: If your present cost allocation to a System Reinforcement indicates \$0, then please be aware that as changes to the interconnection process occur, such as prior queued projects withdrawing from the queue, reducing in size, etc, the cost responsibilities can change and a cost allocation may be assigned to your project. In addition, although your present cost allocation to a System Reinforcement is presently \$0, your project may need this system reinforcement completed to be deliverable to the PJM system. If your project comes into service prior to completion of the system reinforcement, an interim deliverability study for your project will be required.

6 Transmission Owner Scope of Work

The total physical interconnection costs is given in the table below:

6.1 Attachment Facilities

The total preliminary cost estimate for the Attachment work is given in the table below. These costs do not include CIAC Tax Gross-up.

Description	Total Cost
Install necessary equipment (a 69 kV isolation switch structure and associated switch, plus interconnection metering, fiber-optic connection and telecommunications equipment, circuit breaker and associated switches, and relay panels) at Central Hardin substation, to accept the IC generator lead line/bus (Estimated time to implement is 12 months)	\$780,000
Total Attachment Facility Costs	\$780,000

6.2 Direct Connection Cost Estimate

The total preliminary cost estimate for the Direct Connection work is given in the table below. These costs do not include CIAC Tax Gross-up.

Description	Total Cost
None	\$
Total Direct Connection Facility Costs	\$0

6.3 Non-Direct Connection Cost Estimate

The total preliminary cost estimate for the Non-Direct Connection work is given in the table below. These costs do not include CIAC Tax Gross-up.

Description	Total Cost
Install necessary microwave infrastructure at Central Hardin for telecommunications/telemetry needs.	\$130,000
Total Non-Direct Connection Facility Costs	\$130,000

7 Interconnection Customer Requirements

It is understood that the Interconnection Customer (IC) is responsible for all costs associated with this interconnection. The costs above are reimbursable to the Transmission Owner. The cost of the IC's generating plant and the costs for the line connecting the generating plant to the Point of Interconnection are not included in this report; these are assumed to be the IC's responsibility.

The Generation Interconnection Agreement does not in or by itself establish a requirement for the Transmission Owner to provide power for consumption at the developer's facilities. A separate agreement may be reached with the local utility that provides service in the area to ensure that infrastructure is in place to meet this demand and proper metering equipment is installed. It is the responsibility of the developer to contact the local service provider to determine if a local service agreement is required.

1. An Interconnection Customer entering the New Services Queue on or after October 1, 2012 with a proposed new Customer Facility that has a Maximum Facility Output equal to or greater than 100 MW shall install and maintain, at its expense, phasor measurement units (PMUs). See Section 8.5.3 of Appendix 2 to the Interconnection Service Agreement as well as section 4.3 of PJM Manual 14D for additional information.
2. The Interconnection Customer may be required to install and/or pay for metering as necessary to properly track real time output of the facility as well as installing metering which shall be used for billing purposes. See Section 8 of Appendix 2 to the Interconnection Service Agreement as well as Section 4 of PJM Manual 14D for additional information.

8 Revenue Metering and SCADA Requirements

8.1 PJM Requirements

The Interconnection Customer will be required to install equipment necessary to provide Revenue Metering (KWH, KVARH) and real time data (KW, KVAR) for IC's generating Resource. See PJM Manuals M-01 and M-14D, and PJM Tariff Section 8 of Attachment O.

8.2 Meteorological Data Reporting Requirements

The solar generation facility shall provide the Transmission Provider with site-specific meteorological data including:

- Back Panel temperature (Fahrenheit) - (Required for plants with Maximum Facility Output of 3 MW or higher)
- Irradiance (Watts/meter²) - (Required for plants with Maximum Facility Output of 3 MW or higher)
- Ambient air temperature (Fahrenheit) - (Accepted, not required)
- Wind speed (meters/second) - (Accepted, not required)
- Wind direction (decimal degrees from true north) - (Accepted, not required)

8.3 Interconnected Transmission Owner Requirements

The IC will be required to comply with all Interconnected Transmission Owner's revenue metering requirements for generation interconnection customers located at the following link:

<http://www.pjm.com/planning/design-engineering/to-tech-standards/>

9 Summer Peak Analysis

The Queue Project AF2-391 was evaluated as a 120.0 MW (Capacity 72.0 MW) injection at the Central Hardin 69 kV substation in the EKPC area. Project AF2-391 was evaluated for compliance with applicable reliability planning criteria (PJM, NERC, NERC Regional Reliability Councils, and Transmission Owners). Project AF2-391 was studied with a commercial probability of 100%. Potential network impacts were as follows:

9.1 Generation Deliverability

(Single or N-1 contingencies for the Capacity portion only of the interconnection)

- 1.(EKPC - EKPC) The 2CENT HARDIN-2KARGLE 69 kV line (from bus 341287 to bus 341713 ckt 1) loads from 89.21% to 122.49% (AC power flow) of its normal rating (89 MVA) for non-contingency condition. This project contributes approximately 30.53 MW to the thermal violation.
- 2.(EKPC - LGEE) The 2KARGLE-2ETOWN KU 69 kV line (from bus 341713 to bus 324519 ckt 1) loads from 99.68% to 145.09% (AC power flow) of its normal rating (66 MVA) for non-contingency condition. This project contributes approximately 30.53 MW to the thermal violation.
- 3.(EKPC - EKPC) The AF2-260 TAP-2STEPHENSBRG 69 kV line (from bus 959690 to bus 342307 ckt 1) loads from 97.54% to 110.13% (AC power flow) of its normal rating (89 MVA) for non-contingency condition. This project contributes approximately 11.77 MW to the thermal violation.

9.2 Multiple Facility Contingency

(Double Circuit Tower Line, Fault with a Stuck Breaker, and Bus Fault contingencies for the full energy output)

- 1.(LGEE - EKPC) The 2ETOWN KU-2KARGLE 69 kV line (from bus 324519 to bus 341713 ckt 1) loads from 71.69% to 194.09% (AC power flow) of its emergency rating (76 MVA) for the bus fault outage of 'EKPC_P2-2_CENT HARD 138'. This project contributes approximately 90.03 MW to the thermal violation.

```
CONTINGENCY 'EKPC_P2-2_CENT HARD 138'          /* CENTRAL HARDIN
138 BUS
  OPEN BRANCH FROM BUS 341287 TO BUS 342568 CKT 1      /* 341287 2CENT
HARDIN69.000 342568 4CENT HARDIN138.00
END
```

- 2.(LGEE - EKPC) The 2ETOWN KU-2KARGLE 69 kV line (from bus 324519 to bus 341713 ckt 1) loads from 68.18% to 190.4% (AC power flow) of its emergency rating (76 MVA) for the bus fault outage of 'EKPC_P2-3_CHARD W124-804'. This project contributes approximately 89.45 MW to the thermal violation.

```
CONTINGENCY 'EKPC_P2-3_CHARD W124-804'        /* CENTRAL HARDIN
  OPEN BRANCH FROM BUS 341287 TO BUS 342568 CKT 1      /* 341287 2CENT
```

HARDIN69.000 342568 4CENT HARDIN138.00
 OPEN BRANCH FROM BUS 324047 TO BUS 342568 CKT 1 /* 324047
 4BLACKBRNCH 138.00 342568 4CENT HARDIN138.00
 OPEN BRANCH FROM BUS 324047 TO BUS 324260 CKT 1 /* 324047
 4BLACKBRNCH 138.00 324260 4HARDBG 138.00
 END

3.(EKPC - EKPC) The 2KARGLE-2CENT HARDIN 69 kV line (from bus 341713 to bus 341287 ckt 1) loads from 41.4% to 132.88% (AC power flow) of its emergency rating (98 MVA) for the bus fault outage of 'EKPC_P2-3_CHARD W124-804'. This project contributes approximately 89.45 MW to the thermal violation.

CONTINGENCY 'EKPC_P2-3_CHARD W124-804' /* CENTRAL HARDIN
 OPEN BRANCH FROM BUS 341287 TO BUS 342568 CKT 1 /* 341287 2CENT
 HARDIN69.000 342568 4CENT HARDIN138.00
 OPEN BRANCH FROM BUS 324047 TO BUS 342568 CKT 1 /* 324047
 4BLACKBRNCH 138.00 342568 4CENT HARDIN138.00
 OPEN BRANCH FROM BUS 324047 TO BUS 324260 CKT 1 /* 324047
 4BLACKBRNCH 138.00 324260 4HARDBG 138.00
 END

4.(EKPC - EKPC) The 2KARGLE-2CENT HARDIN 69 kV line (from bus 341713 to bus 341287 ckt 1) loads from 40.16% to 131.94% (AC power flow) of its emergency rating (98 MVA) for the bus fault outage of 'EKPC_P2-2_CENT HARD 138'. This project contributes approximately 90.03 MW to the thermal violation.

CONTINGENCY 'EKPC_P2-2_CENT HARD 138' /* CENTRAL HARDIN
 138 BUS
 OPEN BRANCH FROM BUS 341287 TO BUS 342568 CKT 1 /* 341287 2CENT
 HARDIN69.000 342568 4CENT HARDIN138.00
 END

5.(EKPC - EKPC) The 2STEPHENSBRG-2UPTON T 69 kV line (from bus 342307 to bus 342403 ckt 1) loads from 90.44% to 107.36% (AC power flow) of its emergency rating (39 MVA) for the bus fault outage of 'EKPC_P2-2_KU HODG 69'. This project contributes approximately 8.36 MW to the thermal violation.

CONTINGENCY 'EKPC_P2-2_KU HODG 69' /* KU HODGENVILLE 69
 TIE

OPEN BUS 341632 /* 2HODGENVILLE
END

6.(EKPC - EKPC) The AF2-308 TAP-2CENT HARDIN 69 kV line (from bus 960170 to bus 341287 ckt 1) loads from 98.58% to 134.07% (AC power flow) of its emergency rating (98 MVA) for the bus fault outage of 'EKPC_P2-4_CHARD W124-91T'. This project contributes approximately 30.55 MW to the thermal violation.

CONTINGENCY 'EKPC_P2-4_CHARD W124-91T' /* CENTRAL HARDIN
OPEN BRANCH FROM BUS 324047 TO BUS 342568 CKT 1 /* 324047
4BLACKBRNCH 138.00 342568 4CENT HARDIN138.00
OPEN BRANCH FROM BUS 324047 TO BUS 324260 CKT 1 /* 324047
4BLACKBRNCH 138.00 324260 4HARDBG 138.00
OPEN BRANCH FROM BUS 324261 TO BUS 342568 CKT 1 /* 324261 4HARDN
138.00 342568 4CENT HARDIN138.00
END

7.(EKPC - EKPC) The AF2-308 TAP-2CENT HARDIN 69 kV line (from bus 960170 to bus 341287 ckt 1) loads from 98.57% to 134.07% (AC power flow) of its emergency rating (98 MVA) for the line fault with failed breaker contingency outage of 'EKPC_P4-2_CHARD W124-814'. This project contributes approximately 30.55 MW to the thermal violation.

CONTINGENCY 'EKPC_P4-2_CHARD W124-814' /* CENTRAL HARDIN
OPEN BRANCH FROM BUS 341287 TO BUS 342568 CKT 1 /* 341287 2CENT
HARDIN69.000 342568 4CENT HARDIN138.00
OPEN BRANCH FROM BUS 324261 TO BUS 342568 CKT 1 /* 324261 4HARDN
138.00 342568 4CENT HARDIN138.00
END

9.3 Contribution to Previously Identified Overloads

(This project contributes to the following contingency overloads, i.e. "Network Impacts", identified for earlier generation or transmission interconnection projects in the PJM Queue)

1.(LGEE - OVEC) The 7TRIMBL REAC-06CLIFTY 345 kV line (from bus 324010 to bus 248000 ckt 1) loads from 130.05% to 131.12% (DC power flow) of its emergency rating (1451 MVA) for the single line contingency outage of 'AEP_P1-2_#363'. This project contributes approximately 15.62 MW to the thermal violation.

CONTINGENCY 'AEP_P1-2_#363'
OPEN BRANCH FROM BUS 243208 TO BUS 243209 CKT 1 / 243208 05JEFRSO
765 243209 05ROCKPT 765 1

END

2. (LGEE - OVEC) The 7TRIMBL REAC-06CLIFTY 345 kV line (from bus 324010 to bus 248000 ckt 1) loads from 115.35% to 116.75% (AC power flow) of its normal rating (1134 MVA) for non-contingency condition. This project contributes approximately 15.4 MW to the thermal violation.

3.(EKPC - EKPC) The 2CENT HARDIN-2KARGLE 69 kV line (from bus 341287 to bus 341713 ckt 1) loads from 156.5% to 198.4% (AC power flow) of its emergency rating (98 MVA) for the single line contingency outage of 'EKPC_P1-2_CHARD-HARD138'. This project contributes approximately 40.88 MW to the thermal violation.

```
CONTINGENCY 'EKPC_P1-2_CHARD-HARD138'          /* CENTRAL
HARDIN - KU HARDIN
  OPEN BRANCH FROM BUS 324261 TO BUS 342568 CKT 1      /* 324261 4HARDN
138.00 342568 4CENT HARDIN138.00
END
```

4.(EKPC - LGEE) The 2KARGLE-2ETOWN KU 69 kV line (from bus 341713 to bus 324519 ckt 1) loads from 184.06% to 238.31% (AC power flow) of its emergency rating (76 MVA) for the single line contingency outage of 'EKPC_P1-2_CHARD-HARD138'. This project contributes approximately 40.88 MW to the thermal violation.

```
CONTINGENCY 'EKPC_P1-2_CHARD-HARD138'          /* CENTRAL
HARDIN - KU HARDIN
  OPEN BRANCH FROM BUS 324261 TO BUS 342568 CKT 1      /* 324261 4HARDN
138.00 342568 4CENT HARDIN138.00
END
```

5.(EKPC - EKPC) The AF2-260 TAP-2STEPHENSBRG 69 kV line (from bus 959690 to bus 342307 ckt 1) loads from 106.81% to 125.45% (AC power flow) of its emergency rating (98 MVA) for the single line contingency outage of 'EKPC_P1-2_C HAR-KU ETN69'. This project contributes approximately 19.31 MW to the thermal violation.

```
CONTINGENCY 'EKPC_P1-2_C HAR-KU ETN69'          /* CENTRAL HARDIN - KU ETOWN
  OPEN BRANCH FROM BUS 341287 TO BUS 341713 CKT 1      /* 341287 2CENT
HARDIN69.000 341713 2KARGLE 69.000
  OPEN BRANCH FROM BUS 324519 TO BUS 341713 CKT 1      /* 324519 2ETOWN
KU 69.000 341713 2KARGLE 69.000
END
```

6.(EKPC - EKPC) The AF2-308 TAP-2CENT HARDIN 69 kV line (from bus 960170 to bus 341287 ckt 1) loads from 125.33% to 144.96% (AC power flow) of its emergency rating (98 MVA) for the bus fault outage of 'EKPC_P2-2_KU HODG 69'. This project contributes approximately 16.59 MW to the thermal violation.

```
CONTINGENCY 'EKPC_P2-2_KU HODG 69'                /* KU HODGENVILLE 69
TIE
OPEN BUS 341632                                /* 2HODGENVILLE
END
```

9.4 Steady-State Voltage Requirements

To be determined.

9.5 Potential Congestion due to Local Energy Deliverability

PJM also studied the delivery of the energy portion of this interconnection request. Any problems identified below are likely to result in operational restrictions to the project under study. The developer can proceed with network upgrades to eliminate the operational restriction at their discretion by submitting a Merchant Transmission Interconnection request.

Note: Only the most severely overloaded conditions are listed below. There is no guarantee of full delivery of energy for this project by fixing only the conditions listed in this section. With a Transmission Interconnection Request, a subsequent analysis will be performed which shall study all overload conditions associated with the overloaded element(s) identified.

1. (LGEE - OVEC) The 7TRIMBL REAC-06CLIFTY 345 kV line (from bus 324010 to bus 248000 ckt 1) loads from 136.33% to 138.17% (AC power flow) of its emergency rating (1451 MVA) for the single line contingency outage of 'AEP_P1-2_#363'. This project contributes approximately 26.03 MW to the thermal violation.

```
CONTINGENCY 'AEP_P1-2_#363'
OPEN BRANCH FROM BUS 243208 TO BUS 243209 CKT 1      / 243208 05JEFRSO
765 243209 05ROCKPT 765 1
END
```

2. (LGEE - OVEC) The 7TRIMBL REAC-06CLIFTY 345 kV line (from bus 324010 to bus 248000 ckt 1) loads from 122.66% to 124.97% (AC power flow) of its normal rating (1134 MVA) for non-contingency condition. This project contributes approximately 25.67 MW to the thermal violation.

3. (LGEE - OVEC) The 7TRIMBL REAC-06CLIFTY 345 kV line (from bus 324010 to bus 248000 ckt 1) loads from 122.66% to 124.97% (AC power flow) of its normal rating (1134 MVA) for non-contingency condition. This project contributes approximately 25.67 MW to the thermal violation.

4. (EKPC - EKPC) The 2CENT HARDIN-2KARGLE 69 kV line (from bus 341287 to bus 341713 ckt 1) loads from 196.85% to 266.7% (AC power flow) of its emergency rating (98 MVA) for the single line contingency outage of 'EKPC_P1-2_CHARD-HARD138'. This project contributes approximately 68.13 MW to the thermal violation.

```
CONTINGENCY 'EKPC_P1-2_CHARD-HARD138'          /* CENTRAL
HARDIN - KU HARDIN
  OPEN BRANCH FROM BUS 324261 TO BUS 342568 CKT 1      /* 324261 4HARDN
138.00 342568 4CENT HARDIN138.00
END
```

5. (EKPC - EKPC) The 2CENT HARDIN-2KARGLE 69 kV line (from bus 341287 to bus 341713 ckt 1) loads from 108.67% to 164.31% (AC power flow) of its normal rating (89 MVA) for non-contingency condition. This project contributes approximately 50.88 MW to the thermal violation.

6. (EKPC - EKPC) The 2CENT HARDIN-2KARGLE 69 kV line (from bus 341287 to bus 341713 ckt 1) loads from 108.67% to 164.31% (AC power flow) of its normal rating (89 MVA) for non-contingency condition. This project contributes approximately 50.88 MW to the thermal violation.

7. (EKPC - LGEE) The 2KARGLE-2ETOWN KU 69 kV line (from bus 341713 to bus 324519 ckt 1) loads from 236.06% to 326.36% (AC power flow) of its emergency rating (76 MVA) for the single line contingency outage of 'EKPC_P1-2_CHARD-HARD138'. This project contributes approximately 68.13 MW to the thermal violation.

```
CONTINGENCY 'EKPC_P1-2_CHARD-HARD138'          /* CENTRAL
HARDIN - KU HARDIN
  OPEN BRANCH FROM BUS 324261 TO BUS 342568 CKT 1      /* 324261 4HARDN
138.00 342568 4CENT HARDIN138.00
END
```

8. (EKPC - LGEE) The 2KARGLE-2ETOWN KU 69 kV line (from bus 341713 to bus 324519 ckt 1) loads from 125.93% to 201.6% (AC power flow) of its normal rating (66 MVA) for non-contingency condition. This project contributes approximately 50.88 MW to the thermal violation.

9. (EKPC - LGEE) The 2KARGLE-2ETOWN KU 69 kV line (from bus 341713 to bus 324519 ckt 1) loads from 125.93% to 201.6% (AC power flow) of its normal rating (66 MVA) for non-contingency condition. This project contributes approximately 50.88 MW to the thermal violation.

10. (EKPC - EKPC) The 2STEPHENSBRG-2UPTON T 69 kV line (from bus 342307 to bus 342403 ckt 1) loads from 83.91% to 104.96% (AC power flow) of its emergency rating (39 MVA) for the single line contingency outage of 'EKPC_P1-2_C HAR-KU ETN69'. This project contributes approximately 10.44 MW to the thermal violation.

```
CONTINGENCY 'EKPC_P1-2_C HAR-KU ETN69'          /* CENTRAL HARDIN - KU ETOWN
  OPEN BRANCH FROM BUS 341287 TO BUS 341713 CKT 1    /* 341287 2CENT
HARDIN69.000 341713 2KARGLE 69.000
  OPEN BRANCH FROM BUS 324519 TO BUS 341713 CKT 1    /* 324519 2ETOWN
KU 69.000 341713 2KARGLE 69.000
END
```

11. (EKPC - LGEE) The 4CENT HARDIN-4HARDIN CO 138 kV line (from bus 342568 to bus 324261 ckt 1) loads from 95.6% to 123.08% (AC power flow) of its emergency rating (265 MVA) for the single line contingency outage of 'EKPC_P1-2_C HAR-KU ETN69'. This project contributes approximately 71.65 MW to the thermal violation.

```
CONTINGENCY 'EKPC_P1-2_C HAR-KU ETN69'          /* CENTRAL HARDIN - KU ETOWN
  OPEN BRANCH FROM BUS 341287 TO BUS 341713 CKT 1    /* 341287 2CENT
HARDIN69.000 341713 2KARGLE 69.000
  OPEN BRANCH FROM BUS 324519 TO BUS 341713 CKT 1    /* 324519 2ETOWN
KU 69.000 341713 2KARGLE 69.000
END
```

12. (EKPC - LGEE) The 4CENT HARDIN-4HARDIN CO 138 kV line (from bus 342568 to bus 324261 ckt 1) loads from 87.02% to 104.22% (AC power flow) of its normal rating (208 MVA) for non-contingency condition. This project contributes approximately 34.57 MW to the thermal violation.

13. (EKPC - LGEE) The 4CENT HARDIN-4HARDIN CO 138 kV line (from bus 342568 to bus 324261 ckt 1) loads from 87.02% to 104.22% (AC power flow) of its normal rating (208 MVA) for non-contingency condition. This project contributes approximately 34.57 MW to the thermal violation.

14. (EKPC - EKPC) The 4CENT HARDIN 138/69 kV transformer (from bus 342568 to bus 341287 ckt 1) loads from 95.19% to 111.66% (AC power flow) of its emergency rating (175 MVA) for the single line contingency outage of 'EKPC_P1-2_CHARD-HARD138'. This project contributes approximately 28.72 MW to the thermal violation.

```
CONTINGENCY 'EKPC_P1-2_CHARD-HARD138'          /* CENTRAL HARDIN - KU HARDIN
OPEN BRANCH FROM BUS 324261 TO BUS 342568 CKT 1    /* 324261 4HARDN
138.00 342568 4CENT HARDIN138.00
END
```

15. (EKPC - EKPC) The AF2-111 TAP-7SPURLOCK 345 kV line (from bus 958170 to bus 342838 ckt 1) loads from 105.54% to 106.48% (AC power flow) of its emergency rating (1151 MVA) for the single line contingency outage of 'AEP_P1-2_#1027'. This project contributes approximately 13.18 MW to the thermal violation.

```
CONTINGENCY 'AEP_P1-2_#1027'
OPEN BRANCH FROM BUS 248000 TO BUS 324010 CKT 1    / 248000 06CLIFTY
345 324010 7TRIMBL REAC 345 1
OPEN BRANCH FROM BUS 324010 TO BUS 324114 CKT 1    / 324010 7TRIMBL
REAC 345 324114 7TRIMBLE CO 345 1
END
```

16. (EKPC - EKPC) The AF2-111 TAP-7SPURLOCK 345 kV line (from bus 958170 to bus 342838 ckt 1) loads from 103.46% to 104.3% (AC power flow) of its normal rating (1056 MVA) for non-contingency condition. This project contributes approximately 10.74 MW to the thermal violation.

17. (EKPC - EKPC) The AF2-111 TAP-7SPURLOCK 345 kV line (from bus 958170 to bus 342838 ckt 1) loads from 103.46% to 104.3% (AC power flow) of its normal rating (1056 MVA) for non-contingency condition. This project contributes approximately 10.74 MW to the thermal violation.

18. (EKPC - EKPC) The AF2-260 TAP-2STEPHENSBRG 69 kV line (from bus 959690 to bus 342307 ckt 1) loads from 133.99% to 165.16% (AC power flow) of its emergency rating (98 MVA) for the single line contingency outage of 'EKPC_P1-2_C HAR-KU ETN69'. This project contributes approximately 32.18 MW to the thermal violation.

```
CONTINGENCY 'EKPC_P1-2_C HAR-KU ETN69'          /* CENTRAL HARDIN - KU ETOWN
  OPEN BRANCH FROM BUS 341287 TO BUS 341713 CKT 1    /* 341287 2CENT
HARDIN69.000 341713 2KARGLE 69.000
  OPEN BRANCH FROM BUS 324519 TO BUS 341713 CKT 1    /* 324519 2ETOWN
KU 69.000 341713 2KARGLE 69.000
END
```

19. (EKPC - EKPC) The AF2-260 TAP-2STEPHENSBRG 69 kV line (from bus 959690 to bus 342307 ckt 1) loads from 122.63% to 143.67% (AC power flow) of its normal rating (89 MVA) for non-contingency condition. This project contributes approximately 19.62 MW to the thermal violation.

20. (EKPC - EKPC) The AF2-260 TAP-2STEPHENSBRG 69 kV line (from bus 959690 to bus 342307 ckt 1) loads from 122.63% to 143.67% (AC power flow) of its normal rating (89 MVA) for non-contingency condition. This project contributes approximately 19.62 MW to the thermal violation.

21. (EKPC - EKPC) The AF2-308 TAP-2CENT HARDIN 69 kV line (from bus 960170 to bus 341287 ckt 1) loads from 106.21% to 131.09% (AC power flow) of its normal rating (89 MVA) for non-contingency condition. This project contributes approximately 19.62 MW to the thermal violation.

22. (EKPC - EKPC) The AF2-308 TAP-2CENT HARDIN 69 kV line (from bus 960170 to bus 341287 ckt 1) loads from 106.21% to 131.09% (AC power flow) of its normal rating (89 MVA) for non-contingency condition. This project contributes approximately 19.62 MW to the thermal violation.

23. (EKPC - EKPC) The AF2-308 TAP-2CENT HARDIN 69 kV line (from bus 960170 to bus 341287 ckt 1) loads from 100.98% to 125.14% (AC power flow) of its emergency rating (98 MVA) for the single line contingency outage of 'EKPC_P1-2_CHARD-HRDBG138'. This project contributes approximately 20.76 MW to the thermal violation.

```
CONTINGENCY 'EKPC_P1-2_CHARD-HRDBG138'          /* CENTRAL HARDIN - HARDINSBURG
  OPEN BRANCH FROM BUS 324047 TO BUS 342568 CKT 1    /* 324047
4BLACKBRNCH 138.00 342568 4CENT HARDIN138.00
  OPEN BRANCH FROM BUS 324047 TO BUS 324260 CKT 1    /* 324047
4BLACKBRNCH 138.00 324260 4HARDBG 138.00
END
```

24. (EKPC - EKPC) The AF2-308 TAP-AF2-260 TAP 69 kV line (from bus 960170 to bus 959690 ckt 1) loads from 91.92% to 122.91% (AC power flow) of its emergency rating (98 MVA) for the single line contingency outage of 'EKPC_P1-2_C HAR-KU ETN69'. This project contributes approximately 32.18 MW to the thermal violation.

```
CONTINGENCY 'EKPC_P1-2_C HAR-KU ETN69'          /* CENTRAL HARDIN - KU ETOWN
  OPEN BRANCH FROM BUS 341287 TO BUS 341713 CKT 1    /* 341287 2CENT
HARDIN69.000 341713 2KARGLE 69.000
  OPEN BRANCH FROM BUS 324519 TO BUS 341713 CKT 1    /* 324519 2ETOWN
KU 69.000 341713 2KARGLE 69.000
END
```

25. (EKPC - EKPC) The AF2-308 TAP-AF2-260 TAP 69 kV line (from bus 960170 to bus 959690 ckt 1) loads from 82.89% to 103.73% (AC power flow) of its normal rating (89 MVA) for non-contingency condition. This project contributes approximately 19.62 MW to the thermal violation.

26. (EKPC - EKPC) The AF2-308 TAP-AF2-260 TAP 69 kV line (from bus 960170 to bus 959690 ckt 1) loads from 82.89% to 103.73% (AC power flow) of its normal rating (89 MVA) for non-contingency condition. This project contributes approximately 19.62 MW to the thermal violation.

9.6 System Reinforcements

Facility	Upgrade Description	Cost	Cost Allocated to AF2-090	Upgrade Number
2STEPHENSBRG-2UPTON T 69 kV line (from bus 342307 to bus 342403 ckt 1)	<p><u>EKPC Reinforcement:</u> <u>Project ID:</u> n6238 Increase the maximum operating temperature of the 4/0 ACSR conductor in the Stephensburg-Upton Tap 69 kV line section to 212 degrees F (10.75 miles) \$750K. 18 months. 49/54 MVA SN/SE. <u>Type:</u> FAC <u>Cost:</u> \$750,000 <u>Time Estimate:</u> 18 Months <u>Ratings:</u> 49/54 MVA SN/SE</p> <p><u>Notes:</u> AF2-391 is the driver for this upgrade.</p>	\$750,000	\$750,000	N8009
7TRIMBL REAC-06CLIFTY 345 kV line (from bus 324010 to bus 248000 ckt 1)	<p><u>LG&E:</u> Trimble-Clifty 345 kV line is a tie line between LG&E and OVEC. The line is owned by LG&E. The potential upgrade on the Trimble-Clifty 345 kV line, if determined to be a constraint by LG&E, is to reconductor the line with a high temperature conductor and upgrade necessary terminal equipment to achieve ratings of 2610/2610 MVA SN/SE. Cost estimate is \$17.4M with a time estimate of 18 months.</p> <p>**LG&E will determine if there are any LG&E system impacts, including on Trimble- Clifty line. Final LG&E Impacts and necessary LG&E system upgrade(s) will be determined once the LG&E affected system study is completed by LG&E.</p> <p><u>OVEC:</u> No upgrades required</p>	\$17,400,000	TBD**	N/A

2CENT HARDIN-2KARGLE 69 kV line (from bus 341287 to bus 341713 ckt 1))	<p><u>EKPC Reinforcement:</u> Project ID: n6238 Increase the operating temperature of the 556.5 MCM ACSR/TW conductor from 212F to 302F. EKPC's new rating would be Normal 103 MVA/Emergency 129 MVA. Cost of upgrade: \$40,000. Time to complete 6 months. Type: FAC Cost: \$40,000 Time Estimate: 6 Months Ratings: 103/129 MVA SN/SE</p> <p>The cost allocation table is as follows:</p> <table border="1"> <thead> <tr> <th>Queue</th> <th>MW contribution</th> <th>% Allocation</th> <th>Cost \$40 K</th> </tr> </thead> <tbody> <tr> <td>AF2-260</td> <td>23.5</td> <td>24.8%</td> <td>9.916</td> </tr> <tr> <td>AF2-308</td> <td>12.2</td> <td>12.9%</td> <td>5.148</td> </tr> <tr> <td>AF2-309</td> <td>18.2</td> <td>19.2%</td> <td>7.679</td> </tr> <tr> <td>AF2-391</td> <td>40.9</td> <td>43.1%</td> <td>17.257</td> </tr> </tbody> </table>	Queue	MW contribution	% Allocation	Cost \$40 K	AF2-260	23.5	24.8%	9.916	AF2-308	12.2	12.9%	5.148	AF2-309	18.2	19.2%	7.679	AF2-391	40.9	43.1%	17.257			
	Queue	MW contribution	% Allocation	Cost \$40 K																				
	AF2-260	23.5	24.8%	9.916																				
	AF2-308	12.2	12.9%	5.148																				
AF2-309	18.2	19.2%	7.679																					
AF2-391	40.9	43.1%	17.257																					
<p><u>EKPC Reinforcement:</u> Project ID: n6238.1 Replace the 556 MCM ACSR jumpers at the Central Hardin substation using bundled 500 MCM copper or equivalent. EKPC's new rating would be Normal 103 MVA/Emergency 132 MVA. Cost of upgrade: \$15,000. Time to complete 6 months. Type: FAC Cost: \$15,000 Time Estimate: 6 Months Ratings: 103/132 MVA SN/SE</p> <p>The cost allocation table is as follows:</p> <table border="1"> <thead> <tr> <th>Queue</th> <th>MW contribution</th> <th>% Allocation</th> <th>Cost \$15 K</th> </tr> </thead> <tbody> <tr> <td>AF2-309</td> <td>18.2</td> <td>30.8%</td> <td>4.619</td> </tr> <tr> <td>AF2-391</td> <td>40.9</td> <td>69.2%</td> <td>10.381</td> </tr> </tbody> </table>	Queue	MW contribution	% Allocation	Cost \$15 K	AF2-309	18.2	30.8%	4.619	AF2-391	40.9	69.2%	10.381	\$40,000 + \$15,000 + \$450,000 + \$0	\$17,257 + \$10,381 + \$311,421 + \$0	N6238 N6238.1 N6238.2 N6238.3									
Queue	MW contribution	% Allocation	Cost \$15 K																					
AF2-309	18.2	30.8%	4.619																					
AF2-391	40.9	69.2%	10.381																					
<p><u>EKPC Reinforcement:</u> Project ID: n6238.2 Rebuild the Central Hardin-Kargle 69 kV line section using 954 MCM ACSS conductor at 392 degrees F (0.6 miles). EKPC's new rating would be Normal 114 MVA/Emergency 146 MVA. Cost of upgrade: \$450,000. Time to complete 12 months. Type: FAC Cost: \$450,000 Time Estimate: 12 Months Ratings: 114/146 MVA SN/SE</p> <p>The cost allocation table is as follows:</p> <table border="1"> <thead> <tr> <th>Queue</th> <th>MW contribution</th> <th>% Allocation</th> <th>Cost \$450 K</th> </tr> </thead> <tbody> <tr> <td>AF2-309</td> <td>18.2</td> <td>30.8%</td> <td>138.579</td> </tr> <tr> <td>AF2-391</td> <td>40.9</td> <td>69.2%</td> <td>311.421</td> </tr> </tbody> </table>	Queue	MW contribution	% Allocation	Cost \$450 K	AF2-309	18.2	30.8%	138.579	AF2-391	40.9	69.2%	311.421												
Queue	MW contribution	% Allocation	Cost \$450 K																					
AF2-309	18.2	30.8%	138.579																					
AF2-391	40.9	69.2%	311.421																					

Facility	Upgrade Description	Cost	Cost Allocated to AF2-090	Upgrade Number
	<p><u>EKPC Reinforcement:</u> <u>Project ID:</u> n6238.3 Change the Zone 3 relay setting at Central Hardin associated with the line protection to at least 228 MVA LTE rating. EKPC's new rating would be Normal 147 MVA/Emergency 228 MVA. Cost of upgrade: \$0. Time to complete 6 months. <u>Type:</u> FAC <u>Cost:</u> \$0 <u>Time Estimate:</u> 6 Months <u>Ratings:</u> 147/228 MVA SN/SE</p>			

Facility	Upgrade Description	Cost	Cost Allocated to AF2-090	Upgrade Number																								
<p>2KARGLE-2ETOWN KU 69 kV line (from bus 341713 to bus 324519 ckt 1)</p>	<p><u>EKPC Reinforcement:</u> <u>Project ID:</u> n7035.1 Increase the maximum operating temperature of the 556 MCM ACSR conductor in the Kargle-KU Elizabethtown 69 kV line section to 302 degrees F (1.45 miles). Cost estimate: \$100 K. Time Estimate: 9 months. New expected SE rating after the upgrade will be 132 MVA. <u>Type:</u> FAC <u>Cost:</u> \$100,000 <u>Time Estimate:</u> 9 Months <u>Ratings:</u> 132 MVA SE</p> <p>The cost allocation table is as follows:</p> <table border="1" data-bbox="396 688 966 961"> <thead> <tr> <th>Queue</th> <th>MW contribution</th> <th>% Allocation</th> <th>Cost \$100 K</th> </tr> </thead> <tbody> <tr> <td>AF2-090</td> <td>29.8</td> <td>23.9%</td> <td>23.917</td> </tr> <tr> <td>AF2-260</td> <td>23.5</td> <td>18.9%</td> <td>18.860</td> </tr> <tr> <td>AF2-308</td> <td>12.2</td> <td>9.8%</td> <td>9.791</td> </tr> <tr> <td>AF2-309</td> <td>18.2</td> <td>14.6%</td> <td>14.607</td> </tr> <tr> <td>AF2-391</td> <td>40.9</td> <td>32.8%</td> <td>32.825</td> </tr> </tbody> </table>	Queue	MW contribution	% Allocation	Cost \$100 K	AF2-090	29.8	23.9%	23.917	AF2-260	23.5	18.9%	18.860	AF2-308	12.2	9.8%	9.791	AF2-309	18.2	14.6%	14.607	AF2-391	40.9	32.8%	32.825	<p>\$100,000 + \$2,010,000</p>	<p>\$32,825 + \$1,391,000</p>	<p>N7035.1 N7035.2</p>
	Queue	MW contribution	% Allocation	Cost \$100 K																								
AF2-090	29.8	23.9%	23.917																									
AF2-260	23.5	18.9%	18.860																									
AF2-308	12.2	9.8%	9.791																									
AF2-309	18.2	14.6%	14.607																									
AF2-391	40.9	32.8%	32.825																									
<p><u>EKPC Reinforcement:</u> <u>Project ID:</u> n7035.2 Rebuild the 556 MCM ACSR conductor section of the Kargle-KU Elizabethtown 69 kV line section using 954 MCM ACSR conductor (1.45 miles). Cost estimate: \$2.01 M. Time Estimate: 15 months. New expected SE rating after the upgrade will be 182 MVA. <u>Type:</u> FAC <u>Cost:</u> \$2,010,000 <u>Time Estimate:</u> 15 Months <u>Ratings:</u> 182 MVA SE</p> <p>The cost allocation table is as follows:</p> <table border="1" data-bbox="396 1394 966 1537"> <thead> <tr> <th>Queue</th> <th>MW contribution</th> <th>% Allocation</th> <th>Cost \$2.01 M</th> </tr> </thead> <tbody> <tr> <td>AF2-309</td> <td>18.2</td> <td>30.8%</td> <td>0.619</td> </tr> <tr> <td>AF2-391</td> <td>40.9</td> <td>69.2%</td> <td>1.391</td> </tr> </tbody> </table> <p><u>LG&E:</u> LG&E impacts to be determined during the LG&E affected system study.</p>	Queue	MW contribution	% Allocation	Cost \$2.01 M	AF2-309	18.2	30.8%	0.619	AF2-391	40.9	69.2%	1.391																
Queue	MW contribution	% Allocation	Cost \$2.01 M																									
AF2-309	18.2	30.8%	0.619																									
AF2-391	40.9	69.2%	1.391																									

Facility	Upgrade Description	Cost	Cost Allocated to AF2-090	Upgrade Number												
<p>AF2-260 TAP-2STEPHENSBRG 69 kV line (from bus 959690 to bus 342307 ckt 1)</p>	<p>EKPC Reinforcement: Project ID: n7149 Increase the maximum operating temperature of the 556 MCM ACSR conductor in the AF2-260 Tap-Stephensburg 69 kV line section to 302 degrees F (2.1 miles). Cost Estimate: 150 K. Time Estimate: 9 months. New expected SE rating after the upgrade will be 125 MVA. Type: FAC Cost: \$150,000 Time Estimate: 9 Months Ratings: 125 MVA SE</p> <p>The cost allocation table is as follows:</p> <table border="1" data-bbox="396 690 967 835"> <thead> <tr> <th>Queue</th> <th>MW contribution</th> <th>% Allocation</th> <th>Cost \$150 K</th> </tr> </thead> <tbody> <tr> <td>AF2-309</td> <td>7.1</td> <td>14.8%</td> <td>22.188</td> </tr> <tr> <td>AF2-391</td> <td>40.9</td> <td>85.2%</td> <td>127.813</td> </tr> </tbody> </table>	Queue	MW contribution	% Allocation	Cost \$150 K	AF2-309	7.1	14.8%	22.188	AF2-391	40.9	85.2%	127.813	\$150,000	\$127,813	N7149
Queue	MW contribution	% Allocation	Cost \$150 K													
AF2-309	7.1	14.8%	22.188													
AF2-391	40.9	85.2%	127.813													

<p>AF2-308 TAP-2CENT HARDIN 69 kV line (from bus 960170 to bus 341287 ckt 1)</p>	<p><u>EKPC Reinforcement:</u> <u>Project ID:</u> n7036.1 Increase the maximum operating temperature of the 556 MCM ACSR conductor in the AF2-308 Tap-Central Hardin 69 kV line section to 302 degrees F (4.15 miles). Cost estimate: 280 K \$1,730,000. Time Estimate: 9 months. New expected SE rating after the upgrade will be 129 MVA 103.0/129.0/135.0 MVA. <u>Type:</u> FAC <u>Cost:</u> \$280,000 <u>Time Estimate:</u> 9 Months <u>Ratings:</u> 103/129 MVA SN/SE</p> <p>The cost allocation table is as follows:</p> <table border="1"> <thead> <tr> <th>Queue</th> <th>MW contribution</th> <th>% Allocation</th> <th>Cost \$280 K</th> </tr> </thead> <tbody> <tr> <td>AF2-308</td> <td>28.0</td> <td>23.3%</td> <td>65.230</td> </tr> <tr> <td>AF2-309</td> <td>70.0</td> <td>58.2%</td> <td>163.075</td> </tr> <tr> <td>AF2-365</td> <td>5.6</td> <td>4.7%</td> <td>13.046</td> </tr> <tr> <td>AF2-391</td> <td>16.6</td> <td>13.8%</td> <td>38.649</td> </tr> </tbody> </table>	Queue	MW contribution	% Allocation	Cost \$280 K	AF2-308	28.0	23.3%	65.230	AF2-309	70.0	58.2%	163.075	AF2-365	5.6	4.7%	13.046	AF2-391	16.6	13.8%	38.649			
	Queue	MW contribution	% Allocation	Cost \$280 K																				
	AF2-308	28.0	23.3%	65.230																				
AF2-309	70.0	58.2%	163.075																					
AF2-365	5.6	4.7%	13.046																					
AF2-391	16.6	13.8%	38.649																					
<p><u>EKPC Reinforcement:</u> <u>Project ID:</u> n7036.2 Replace the 556 MCM ACSR jumpers at the Central Hardin substation using bundled 500 MCM copper or equivalent. Cost Estimate: \$25 K. Time Estimate: 6 months. New expected SE rating after the upgrade will be 132 MVA. <u>Type:</u> FAC <u>Cost:</u> \$25,000 <u>Time Estimate:</u> 6 Months <u>Ratings:</u> 132 MVA SE</p> <p>The cost allocation table is as follows:</p> <table border="1"> <thead> <tr> <th>Queue</th> <th>MW contribution</th> <th>% Allocation</th> <th>Cost \$25 K</th> </tr> </thead> <tbody> <tr> <td>AF2-308</td> <td>70.0</td> <td>80.8%</td> <td>20.210</td> </tr> <tr> <td>AF2-309</td> <td>16.6</td> <td>19.2%</td> <td>4.790</td> </tr> </tbody> </table>	Queue	MW contribution	% Allocation	Cost \$25 K	AF2-308	70.0	80.8%	20.210	AF2-309	16.6	19.2%	4.790	<p>\$280,000 + \$25,000 + \$3,210,000</p>	<p>\$38,649 + \$4,790 + \$615,000</p>	<p>N7036.1 N7036.2 N7036.3</p>									
Queue	MW contribution	% Allocation	Cost \$25 K																					
AF2-308	70.0	80.8%	20.210																					
AF2-309	16.6	19.2%	4.790																					
<p><u>EKPC Reinforcement:</u> <u>Project ID:</u> n7036.3 Rebuild the AF2-308 Tap-Central Hardin 69 kV line section using 954 MCM ACSS conductor at 392 degrees F (4.15 miles). Cost Estimate: \$3.21 M. Time Estimate: 16 months. New expected SE rating after the upgrade will be 143 MVA. <u>Type:</u> FAC <u>Cost:</u> \$3,210,000 <u>Time Estimate:</u> 16 Months <u>Ratings:</u> 143 MVA SE</p>																								

Facility	Upgrade Description			Cost	Cost Allocated to AF2-090	Upgrade Number
	The cost allocation table is as follows:					
	Queue	MW contribution	% Allocation	Cost \$3.21 M		
	AF2-308	70.0	80.8%	2.595		
	AF2-309	16.6	19.2%	0.615		
	Total Cost			\$24,430,000	\$3,299,136**	

Note : For customers with System Reinforcements listed: If your present cost allocation to a System Reinforcement indicates \$0, then please be aware that as changes to the interconnection process occur, such as prior queued projects withdrawing from the queue, reducing in size, etc, the cost responsibilities can change and a cost allocation may be assigned to your project. In addition, although your present cost allocation to a System Reinforcement is presently \$0, your project may need this system reinforcement completed to be deliverable to the PJM system. If your project comes into service prior to completion of the system reinforcement, an interim deliverability study for your project will be required.

9.7 Flow Gate Details

The following indices contain additional information about each facility presented in the body of the report. For each index, a description of the flowgate and its contingency was included for convenience. The intent of the indices is to provide more details on which projects/generators have contributions to the flowgate in question. All New Service Queue Requests, through the end of the Queue under study, that are contributors to a flowgate will be listed in the indices. Please note that there may be contributors that are subsequently queued after the queue under study that are not listed in the indices. Although this information is not used "as is" for cost allocation purposes, it can be used to gage the impact of other projects/generators. It should be noted the project/generator MW contributions presented in the body of the report are Full MW Impact contributions which are also noted in the indices column named "Full MW Impact", whereas the loading percentages reported in the body of the report, take into consideration the PJM Generator Deliverability Test rules such as commercial probability of each project as well as the ramping impact of "Adder" contributions. The MW Impact found and used in the analysis is shown in the indices column named "Gendeliv MW Impact".

(LGEE - EKPC) The 2ETOWN KU-2KARGLE 69 kV line (from bus 324519 to bus 341713 ckt 1) loads from 71.69% to 194.09% (AC power flow) of its emergency rating (76 MVA) for the bus fault outage of 'EKPC_P2-2_CENT HARD 138'. This project contributes approximately 90.03 MW to the thermal violation.

CONTINGENCY 'EKPC_P2-2_CENT HARD 138' /* CENTRAL HARDIN
 138 BUS
 OPEN BRANCH FROM BUS 341287 TO BUS 342568 CKT 1 /* 341287 2CENT
 HARDIN69.000 342568 4CENT HARDIN138.00
 END

<i>Bus Number</i>	<i>Bus Name</i>	<i>Full Contribution</i>
957961	AF2-090 C	3.00
957962	AF2-090 E	1.48
960172	AF2-308 BAT	16.31
961003	AF2-391 BAT	90.03
LTF	CALDERWOOD	0.13
LTF	CATAWBA	0.05
LTF	CHEOAH	0.13
LTF	COFFEEN	< 0.01
LTF	EDWARDS	< 0.01
LTF	FARMERCITY	< 0.01
LTF	G-007	0.01
LTF	LGEE	0.19
LTF	NEWTON	0.03
LTF	NY	< 0.01
LTF	O-066	0.07
LTF	PRAIRIE	0.36

(EKPC - EKPC) The 2KARGLE-2CENT HARDIN 69 kV line (from bus 341713 to bus 341287 ckt 1) loads from 41.4% to 132.88% (AC power flow) of its emergency rating (98 MVA) for the bus fault outage of 'EKPC_P2-3_CHARD W124-804'. This project contributes approximately 89.45 MW to the thermal violation.

```
CONTINGENCY 'EKPC_P2-3_CHARD W124-804'          /* CENTRAL HARDIN
OPEN BRANCH FROM BUS 341287 TO BUS 342568 CKT 1    /* 341287 2CENT
HARDIN69.000 342568 4CENT HARDIN138.00
OPEN BRANCH FROM BUS 324047 TO BUS 342568 CKT 1    /* 324047
4BLACKBRNCH 138.00 342568 4CENT HARDIN138.00
OPEN BRANCH FROM BUS 324047 TO BUS 324260 CKT 1    /* 324047
4BLACKBRNCH 138.00 324260 4HARDBG 138.00
END
```

<i>Bus Number</i>	<i>Bus Name</i>	<i>Full Contribution</i>
957961	AF2-090 C	3.66
957962	AF2-090 E	1.81
960172	AF2-308 BAT	16.19
961003	AF2-391 BAT	89.45
LTF	CALDERWOOD	0.13
LTF	CATAWBA	0.05
LTF	CHEOAH	0.13
LTF	COFFEEN	0.01
LTF	EDWARDS	< 0.01
LTF	FARMERCITY	< 0.01
LTF	G-007	< 0.01
LTF	LGEE	0.21
LTF	NEWTON	0.06
LTF	NY	< 0.01
LTF	O-066	0.06
LTF	PRAIRIE	0.44

(EKPC - EKPC) The 2STEPHENSBURG-2UPTON T 69 kV line (from bus 342307 to bus 342403 ckt 1) loads from 90.44% to 107.36% (AC power flow) of its emergency rating (39 MVA) for the bus fault outage of 'EKPC_P2-2_KU HODG 69'. This project contributes approximately 8.36 MW to the thermal violation.

CONTINGENCY 'EKPC_P2-2_KU HODG 69' /* KU HODGENVILLE 69
TIE
OPEN BUS 341632 /* 2HODGENVILLE
END

<i>Bus Number</i>	<i>Bus Name</i>	<i>Full Contribution</i>
959691	AF2-260 C	9.6
959692	AF2-260 E	4.8
960171	AF2-308	3.87
960181	AF2-309 C	5.8
960182	AF2-309 E	3.87
961001	AF2-391 C 01	5.02
961002	AF2-391 E 01	3.35
LTF	CALDERWOOD	0.1
LTF	CATAWBA	0.04
LTF	CBM-W1	0.18
LTF	CHEOAH	0.1
LTF	FARMERCITY	< 0.01
LTF	G-007	0.01
LTF	LGEE	0.11
LTF	NY	< 0.01
LTF	O-066	0.07
LTF	PRAIRIE	0.1
LTF	WEC	< 0.01

(LGEE - OVEC) The 7TRIMBL REAC-06CLIFTY 345 kV line (from bus 324010 to bus 248000 ckt 1) loads from 130.05% to 131.12% (DC power flow) of its emergency rating (1451 MVA) for the single line contingency outage of 'AEP_P1-2_#363'. This project contributes approximately 15.62 MW to the thermal violation.

CONTINGENCY 'AEP_P1-2_#363'

OPEN BRANCH FROM BUS 243208 TO BUS 243209 CKT 1 / 243208 05JEFRSO
 765 243209 05ROCKPT 765 1
 END

<i>Bus Number</i>	<i>Bus Name</i>	<i>Full Contribution</i>
243442	05RKG1	14.7
243443	05RKG2	14.48
342900	1COOPER1 G	2.45
342903	1COOPER2 G	4.75
342918	1JKCT 1G	1.91
342921	1JKCT 2G	1.4
342924	1JKCT 3G	1.91
342927	1JKCT 4G	1.27
342930	1JKCT 5G	1.26
342933	1JKCT 6G	1.27
342936	1JKCT 7G	1.27
342939	1JKCT 9G	1.31
342942	1JKCT 10G	1.31
342945	1LAUREL 1G	1.38
932551	AC2-075 C	0.95
933441	AC2-157 C	4.85
936381	AD2-048 C	3.43
936571	AD2-072 C 01	10.12
939131	AE1-143 C	9.58
940041	AE1-246 C 01	11.96
940831	AE2-071 C	3.03
941341	AE2-130 C	30.62
941411	AE2-138 C	15.16
941981	AE2-210 C 01	5.22
942411	AE2-254 C 01	4.03
942591	AE2-275 C 01	6.82
942601	AE2-276	3.19
942891	AE2-308 C 01	11.52
943111	AE2-339 C	2.56
943701	AF1-038 C	4.66
943821	AF1-050 C	5.42
944151	AF1-083 C 01	4.98
944201	AF1-088 FTIR	63.85
944511	AF1-116 C	10.74
944621	AF1-127 C 01	4.44
945381	AF1-203 C	1.73
945861	AF1-251 C	10.73

957141	AF2-008 FTIR	31.93
957961	AF2-090 C	16.47
959691	AF2-260 C	12.28
960151	AF2-306	1.68
960161	AF2-307 C	2.55
960171	AF2-308	5.81
960181	AF2-309 C	8.72
960641	AF2-355 C 01	15.13
960741	AF2-365 C 01	4.74
961001	AF2-391 C 01	15.62
LTF	CBM-S1	97.41
LTF	CBM-S2	14.8
LTF	CBM-W1	20.42
LTF	CBM-W2	56.26
LTF	CPL	1.2
955451	J1027	13.72
955461	J1028	15.21
955891	J1074	22.99
956911	J1189	0.45
952811	J759	9.7
952821	J762	29.93
952861	J783 C	9.3
953611	J800	14.01
953931	J856	9.41
LTF	LGEE	18.14
LTF	MADISON	12.34
LTF	MEC	6.1
LTF	NY	0.27
LTF	TVA	9.52
LTF	WEC	0.67
930461	AB1-087	35.12
930471	AB1-088	35.12
925981	AC1-074 C 01	3.99

(EKPC - EKPC) The 2CENT HARDIN-2KARGLE 69 kV line (from bus 341287 to bus 341713 ckt 1) loads from 156.5% to 198.4% (AC power flow) of its emergency rating (98 MVA) for the single line contingency outage of 'EKPC_P1-2_CHARD-HARD138'. This project contributes approximately 40.88 MW to the thermal violation.

CONTINGENCY 'EKPC_P1-2_CHARD-HARD138' /* CENTRAL
HARDIN - KU HARDIN
OPEN BRANCH FROM BUS 324261 TO BUS 342568 CKT 1 /* 324261 4HARDN
138.00 342568 4CENT HARDIN138.00
END

<i>Bus Number</i>	<i>Bus Name</i>	<i>Full Contribution</i>
957961	AF2-090 C	29.76
959691	AF2-260 C	23.49
960171	AF2-308	12.16
960181	AF2-309 C	18.24
960741	AF2-365 C 01	1.62
961001	AF2-391 C 01	40.88
LTF	BLUEG	1.1
LTF	CBM-S1	2.85
LTF	CBM-S2	0.98
LTF	CBM-W1	1.59
LTF	CBM-W2	3.58
LTF	CPLE	0.08
952821	J762	13.45
LTF	MADISON	0.86
LTF	MEC	0.42
LTF	NY	< 0.01
LTF	TRIMBLE	0.31
LTF	TVA	0.79
LTF	WEC	0.04

(EKPC - LGEE) The 2KARGLE-2ETOWN KU 69 kV line (from bus 341713 to bus 324519 ckt 1) loads from 184.06% to 238.31% (AC power flow) of its emergency rating (76 MVA) for the single line contingency outage of 'EKPC_P1-2_CHARD-HARD138'. This project contributes approximately 40.88 MW to the thermal violation.

```
CONTINGENCY 'EKPC_P1-2_CHARD-HARD138'          /* CENTRAL
HARDIN - KU HARDIN
OPEN BRANCH FROM BUS 324261 TO BUS 342568 CKT 1      /* 324261 4HARDN
138.00 342568 4CENT HARDIN138.00
END
```

<i>Bus Number</i>	<i>Bus Name</i>	<i>Full Contribution</i>
957961	AF2-090 C	29.76
959691	AF2-260 C	23.49
960171	AF2-308	12.16
960181	AF2-309 C	18.24
960741	AF2-365 C 01	1.62
961001	AF2-391 C 01	40.88
LTF	BLUEG	1.1
LTF	CBM-S1	2.85
LTF	CBM-S2	0.98
LTF	CBM-W1	1.59
LTF	CBM-W2	3.58
LTF	CPLE	0.08
952821	J762	13.45
LTF	MADISON	0.86
LTF	MEC	0.42
LTF	NY	< 0.01
LTF	TRIMBLE	0.31
LTF	TVA	0.79
LTF	WEC	0.04

(EKPC - EKPC) The AF2-260 TAP-2STEPHENSBRG 69 kV line (from bus 959690 to bus 342307 ckt 1) loads from 106.81% to 125.45% (AC power flow) of its emergency rating (98 MVA) for the single line contingency outage of 'EKPC_P1-2_C HAR-KU ETN69'. This project contributes approximately 19.31 MW to the thermal violation.

CONTINGENCY 'EKPC_P1-2_C HAR-KU ETN69' /* CENTRAL HARDIN
 - KU ETOWN
 OPEN BRANCH FROM BUS 341287 TO BUS 341713 CKT 1 /* 341287 2CENT
 HARDIN69.000 341713 2KARGLE 69.000
 OPEN BRANCH FROM BUS 324519 TO BUS 341713 CKT 1 /* 324519 2ETOWN
 KU 69.000 341713 2KARGLE 69.000
 END

<i>Bus Number</i>	<i>Bus Name</i>	<i>Full Contribution</i>
957961	AF2-090 C	5.05
959691	AF2-260 C	28.76
960171	AF2-308	11.98
960181	AF2-309 C	17.98
961001	AF2-391 C 01	19.31
LTF	CALDERWOOD	0.13
LTF	CATAWBA	0.05
LTF	CHEOAH	0.13
LTF	COFFEEN	< 0.01
LTF	FARMERCITY	< 0.01
LTF	LGEE	0.18
LTF	NEWTON	< 0.01
LTF	NY	< 0.01
LTF	PRAIRIE	0.31
LTF	WEC	< 0.01

(EKPC - EKPC) The AF2-308 TAP-2CENT HARDIN 69 kV line (from bus 960170 to bus 341287 ckt 1) loads from 125.33% to 144.96% (AC power flow) of its emergency rating (98 MVA) for the bus fault outage of 'EKPC_P2-2_KU HODG 69'. This project contributes approximately 16.59 MW to the thermal violation.

CONTINGENCY 'EKPC_P2-2_KU HODG 69'

/* KU HODGENVILLE 69

TIE

OPEN BUS 341632

/* 2HODGENVILLE

END

<i>Bus Number</i>	<i>Bus Name</i>	<i>Full Contribution</i>
959691	AF2-260 C	41.13
959692	AF2-260 E	20.57
960171	AF2-308	20.39
960181	AF2-309 C	30.59
960182	AF2-309 E	20.39
960741	AF2-365 C 01	3.37
960742	AF2-365 E 01	2.25
961003	AF2-391 BAT	16.59
LTF	BLUEG	0.88
LTF	CBM-S1	2.48
LTF	CBM-S2	1.01
LTF	CBM-W1	0.38
LTF	CBM-W2	1.81
LTF	CPL	0.09
LTF	G-007A	0.03
LTF	GIBSON	0.05
LTF	MADISON	0.48
LTF	MEC	0.19
LTF	TILTON	0.02
LTF	TRIMBLE	0.25
LTF	TVA	0.63
LTF	VFT	0.07
LTF	WEC	< 0.01

10 Light Load Analysis

The Queue Project AF2-391 was evaluated as a 120.0 MW (Capacity 120.0 MW) injection at the Central Hardin 69 kV substation in the EKPC area. Project AF2-391 was evaluated for compliance with applicable reliability planning criteria (PJM, NERC, NERC Regional Reliability Councils, and Transmission Owners). Project AF2-391 was studied with a commercial probability of 100.0 %. Potential network impacts were as follows:

10.1 Generation Deliverability

(Single or N-1 contingencies for the Capacity portion only of the interconnection)

None

10.2 Multiple Facility Contingency

(Double Circuit Tower Line, Fault with a Stuck Breaker, and Bus Fault contingencies for the full energy output)

None

10.3 Contribution to Previously Identified Overloads

(This project contributes to the following contingency overloads, i.e. "Network Impacts", identified for earlier generation or transmission interconnection projects in the PJM Queue)

None

10.4 Steady-State Voltage Requirements

To be determined

10.5 Potential Congestion due to Local Energy Deliverability

PJM also studied the delivery of the energy portion of this interconnection request. Any problems identified below are likely to result in operational restrictions to the project under study. The developer can proceed with network upgrades to eliminate the operational restriction at their discretion by submitting a Merchant Transmission Interconnection request.

Note: Only the most severely overloaded conditions are listed below. There is no guarantee of full delivery of energy for this project by fixing only the conditions listed in this section. With a Transmission Interconnection Request, a subsequent analysis will be performed which shall study all overload conditions associated with the overloaded element(s) identified.

None

11 Short Circuit Analysis

The following Breakers are overdutied:

None

12 Stability and Reactive Power

(Summary of the VAR requirements based upon the results of the dynamic studies)

To be determined in the Facilities Study Phase.

13 Affected Systems

13.1 TVA

None

13.2 MISO

Preliminary MISO impacts have been identified. Please refer to the MISO Affected System report for details. Final MISO impacts to be determined by MISO during the Facilities Study phase.

13.3 LG&E

An LG&E affected system study is required. An LG&E affected system study agreement will need to be signed.

14 Attachment 1: One Line Diagram

AF2-391 Conceptual Single-Line Diagram of Interconnection Facilities

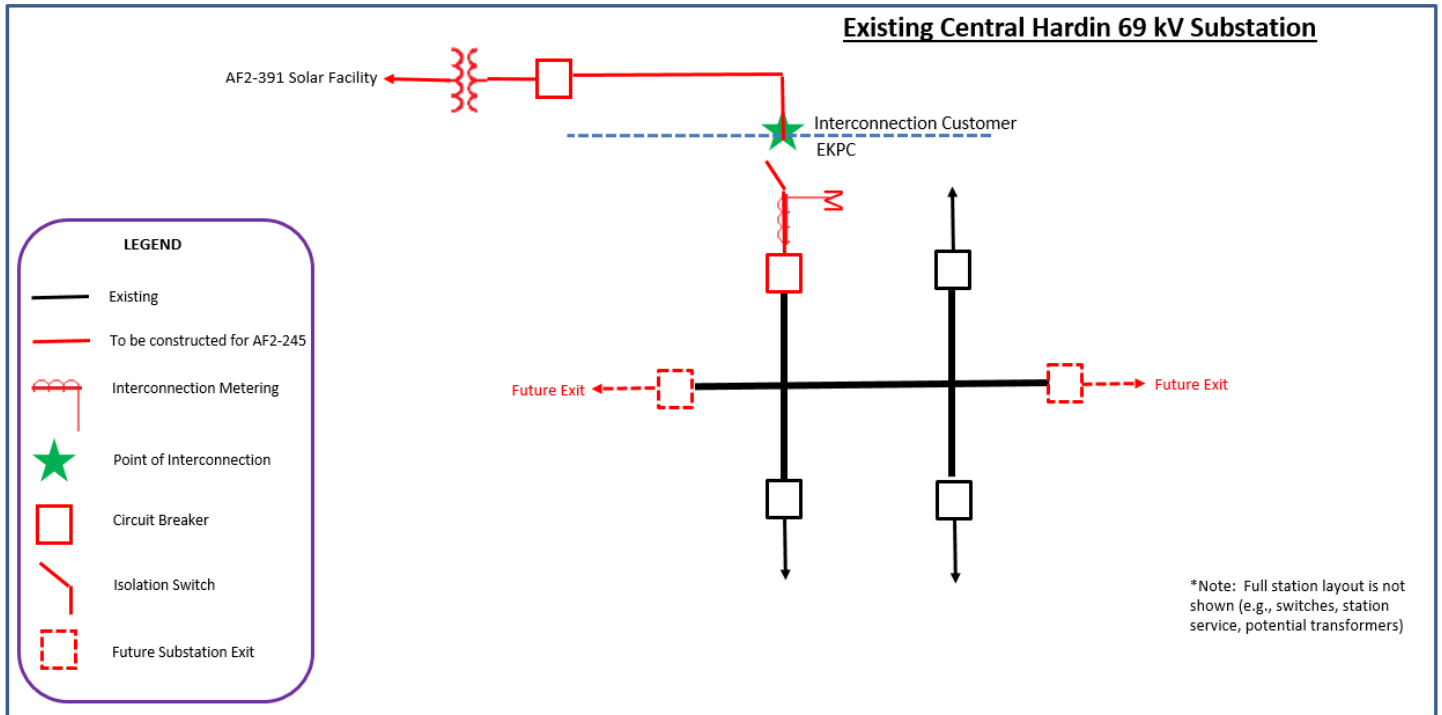



**Generation Interconnection
Feasibility Study Report
for
Queue Project AF2-391
CENTRAL HARDIN 69 KV
72 MW Capacity / 120 MW Energy**

July 2020

Table of Contents

- 1 Introduction..... 4
- 2 Preface..... 4
- 3 General..... 5
- 4 Point of Interconnection..... 6
- 5 Cost Summary 6
- 6 Transmission Owner Scope of Work..... 7
 - 6.1 Attachment Facilities..... 7
 - 6.2 Direct Connection Cost Estimate..... 7
 - 6.3 Non-Direct Connection Cost Estimate..... 7
- 7 Incremental Capacity Transfer Rights (ICTRs) 8
- 8 Interconnection Customer Requirements..... 8
- 9 Revenue Metering and SCADA Requirements 8
 - 9.1 PJM Requirements..... 8
 - 9.2 Meteorological Data Reporting Requirements..... 8
 - 9.3 Interconnected Transmission Owner Requirements..... 9
- 10 Summer Peak - Load Flow Analysis - Primary POI.....10
 - 10.1 Generation Deliverability11
 - 10.2 Multiple Facility Contingency11
 - 10.3 Contribution to Previously Identified Overloads.....12
 - 10.4 Potential Congestion due to Local Energy Deliverability.....12
 - 10.5 System Reinforcements - Summer Peak Load Flow - Primary POI.....14
 - 10.6 Flow Gate Details - Primary POI16
 - 10.6.1 Index 117
 - 10.6.2 Index 218
 - 10.6.3 Index 319
 - 10.6.4 Index 420
 - 10.6.5 Index 522
 - 10.7 Queue Dependencies23
 - 10.8 Contingency Descriptions - Primary POI.....25
- 11 Light Load Analysis.....27
- 12 Short Circuit Analysis – Primary POI.....27

13	Stability and Reactive Power Assessment.....	27
14	Affected Systems	27
14.1	LG&E.....	27
14.2	MISO	27
14.3	TVA.....	27
14.4	Duke Energy Progress.....	27
15	Summer Peak - Load Flow Analysis - Secondary POI	28
15.1	Generation Deliverability	29
15.2	Multiple Facility Contingency	29
15.3	Contribution to Previously Identified Overloads.....	29
15.4	Potential Congestion due to Local Energy Deliverability.....	30
15.5	Flow Gate Details - Secondary POI.....	32
15.5.1	Index 1	33
15.5.2	Index 2	34
15.5.3	Index 3	35
15.5.4	Index 4	36
15.5.5	Index 5	37
15.5.6	Index 6	38
15.5.7	Index 7	40
15.6	Contingency Descriptions - Secondary POI.....	41
16	Light Load Analysis – Secondary POI	43
17	Short Circuit Analysis – Secondary POI.....	43
18	Stability and Reactive Power Assessment – Secondary POI	43
19	Affected Systems – Secondary POI	43
19.1	LG&E.....	43
19.2	MISO	43
19.3	TVA.....	43
19.4	Duke Energy Progress.....	43
20	Attachment 1: One Line Diagram	44

1 Introduction

This Feasibility Study has been prepared in accordance with the PJM Open Access Transmission Tariff, 36.2, as well as the Feasibility Study Agreement between the Interconnection Customer (IC), and PJM Interconnection, LLC (PJM), Transmission Provider (TP). The Interconnected Transmission Owner (ITO) is EKPC.

2 Preface

The intent of the feasibility study is to determine a plan, with ballpark cost and construction time estimates, to connect the subject generation to the PJM network at a location specified by the Interconnection Customer. The Interconnection Customer may request the interconnection of generation as a capacity resource or as an energy-only resource. As a requirement for interconnection, the Interconnection Customer may be responsible for the cost of constructing: (1) Direct Connections, which are new facilities and/or facilities upgrades needed to connect the generator to the PJM network, and (2) Network Upgrades, which are facility additions, or upgrades to existing facilities, that are needed to maintain the reliability of the PJM system.

In some instances a generator interconnection may not be responsible for 100% of the identified network upgrade cost because other transmission network uses, e.g. another generation interconnection, may also contribute to the need for the same network reinforcement. Cost allocation rules for network upgrades can be found in PJM Manual 14A, Attachment B. The possibility of sharing the reinforcement costs with other projects may be identified in the feasibility study, but the actual allocation will be deferred until the impact study is performed.

The Interconnection Customer seeking to interconnect a wind or solar generation facility shall maintain meteorological data facilities as well as provide that meteorological data which is required per Schedule H to the Interconnection Service Agreement and Section 8 of Manual 14D.

An Interconnection Customer with a proposed new Customer Facility that has a Maximum Facility Output equal to or greater than 100 MW shall install and maintain, at its expense, phasor measurement units (PMUs). See Section 8.5.3 of Appendix 2 to the Interconnection Service Agreement as well as section 4.3 of PJM Manual 14D for additional information.

The Feasibility Study estimates do not include the feasibility, cost, or time required to obtain property rights and permits for construction of the required facilities. The project developer is responsible for the right of way, real estate, and construction permit issues. For properties currently owned by Transmission Owners, the costs may be included in the study.

3 General

The Interconnection Customer (IC), has proposed a Solar; Storage generating facility located in Hardin County, Kentucky. The installed facilities will have a total capability of 120 MW with 72 MW of this output being recognized by PJM as Capacity. The proposed in-service date for this project is June 15, 2023. This study does not imply a TO commitment to this in-service date.

Queue Number	AF2-391
Project Name	CENTRAL HARDIN 69 KV
State	Kentucky
County	Hardin
Transmission Owner	EKPC
MFO	120
MWE	120
MWC	72
Fuel	Solar; Storage
Basecase Study Year	2023

Any new service customers who can feasibly be commercially operable prior to June 1st of the basecase study year are required to request interim deliverability analysis.

4 Point of Interconnection

AF2-391 will interconnect with the EKPC transmission system along one of the following Points of Interconnection:

Primary POI: Central Hardin 69 kV substation

Secondary POI: Central Hardin to Stephensburg 69 kV line

5 Cost Summary

The AF2-391 project will be responsible for the following costs:

Description	Total Cost
Total Physical Interconnection Costs	\$910,000
Total System Network Upgrade Costs	\$1,790,000
Total Costs	\$2,700,000

This cost excludes a Federal Income Tax Gross Up charges. This tax may or may not be charged based on whether this project meets the eligibility requirements of IRS Notice 88-129. If at a future date it is determined that the Federal Income Tax Gross charge is required, the Transmission Owner shall be reimbursed by the Interconnection Customer for such taxes.

Cost allocations for any System Upgrades will be provided in the System Impact Study Report.

6 Transmission Owner Scope of Work

6.1 Attachment Facilities

The total preliminary cost estimate for the Attachment work is given in the table below. These costs do not include CIAC Tax Gross-up.

	Total Cost
Install necessary equipment (a 69 kV isolation switch structure and associated switch, plus interconnection metering, fiber-optic connection and telecommunications equipment, circuit breaker and associated switches, and relay panels) at Central Hardin substation, to accept the IC generator lead line/bus (Estimated time to implement is 12 months)	\$780,000
Total Attachment Facility Costs	\$780,000

6.2 Direct Connection Cost Estimate

The total preliminary cost estimate for the Direct Connection work is given in the table below. These costs do not include CIAC Tax Gross-up.

Description	Total Cost
Total Direct Connection Facility Costs	\$0

6.3 Non-Direct Connection Cost Estimate

The total preliminary cost estimate for the Non-Direct Connection work is given in the table below. These costs do not include CIAC Tax Gross-up.

Description	Total Cost
Install necessary microwave infrastructure at Central Hardin for telecommunications/telemetry needs.	\$130,000
Total Non-Direct Connection Facility Costs	\$130,000

7 Incremental Capacity Transfer Rights (ICTRs)

Will be determined at a later study phase

8 Interconnection Customer Requirements

It is understood that the Interconnection Customer (IC) is responsible for all costs associated with this interconnection. The costs above are reimbursable to the Transmission Owner. The cost of the IC's generating plant and the costs for the line connecting the generating plant to the Point of Interconnection are not included in this report; these are assumed to be the IC's responsibility.

The Generation Interconnection Agreement does not in or by itself establish a requirement for the Transmission Owner to provide power for consumption at the developer's facilities. A separate agreement may be reached with the local utility that provides service in the area to ensure that infrastructure is in place to meet this demand and proper metering equipment is installed. It is the responsibility of the developer to contact the local service provider to determine if a local service agreement is required.

1. An Interconnection Customer entering the New Services Queue on or after October 1, 2012 with a proposed new Customer Facility that has a Maximum Facility Output equal to or greater than 100 MW shall install and maintain, at its expense, phasor measurement units (PMUs). See Section 8.5.3 of Appendix 2 to the Interconnection Service Agreement as well as section 4.3 of PJM Manual 14D for additional information.
2. The Interconnection Customer may be required to install and/or pay for metering as necessary to properly track real time output of the facility as well as installing metering which shall be used for billing purposes. See Section 8 of Appendix 2 to the Interconnection Service Agreement as well as Section 4 of PJM Manual 14D for additional information.

9 Revenue Metering and SCADA Requirements

9.1 PJM Requirements

The Interconnection Customer will be required to install equipment necessary to provide Revenue Metering (KWH, KVARH) and real time data (KW, KVAR) for IC's generating Resource. See PJM Manuals M-01 and M-14D, and PJM Tariff Section 8 of Attachment O.

9.2 Meteorological Data Reporting Requirements

Solar generation facilities shall provide the Transmission Provider with site-specific meteorological data including:

- Back Panel temperature (Fahrenheit)
- Irradiance (Watts/meter²)
- Ambient air temperature (Fahrenheit) – (Accepted, not required)
- Wind speed (meters/second) – (Accepted, not required)
- Wind direction (decimal degrees from true north) – (Accepted, not required)

9.3 Interconnected Transmission Owner Requirements

The IC will be required to comply with all Interconnected Transmission Owner's revenue metering requirements for generation interconnection customers located at the following link:

<http://www.pjm.com/planning/design-engineering/to-tech-standards/>

10 Summer Peak - Load Flow Analysis - Primary POI

The Queue Project AF2-391 was evaluated as a 120.0 MW (Capacity 72.0 MW) injection at the Central Hardin 69 kV substation in the EKPC area. Project AF2-391 was evaluated for compliance with applicable reliability planning criteria (PJM, NERC, NERC Regional Reliability Councils, and Transmission Owners). Project AF2-391 was studied with a commercial probability of 53.0 %. Potential network impacts were as follows:

10.1 Generation Deliverability

(Single or N-1 contingencies for the Capacity portion only of the interconnection)

ID	FROM BUS#	FROM BUS	kV	FROM BUS AREA	TO BUS#	TO BUS	kV	TO BUS AREA	CKT ID	CONT NAME	Type	Rating MVA	PRE PROJECT LOADING %	POST PROJECT LOADING %	AC DC	MW IMPACT
102045974	341287	2CENT HARDIN	69.0	EKPC	341713	2KARGLE	69.0	EKPC	1	Base Case	single	89.0	85.34	119.65	DC	30.53

10.2 Multiple Facility Contingency

(Double Circuit Tower Line, Fault with a Stuck Breaker, and Bus Fault contingencies for the full energy output)

ID	FROM BUS#	FROM BUS	kV	FROM BUS AREA	TO BUS#	TO BUS	kV	TO BUS AREA	CKT ID	CONT NAME	Type	Rating MVA	PRE PROJECT LOADING %	POST PROJECT LOADING %	AC DC	MW IMPACT
157526574	341713	2KARGLE	69.0	EKPC	341287	2CENT HARDIN	69.0	EKPC	1	EKPC_P2-2_CENT HARD 138	bus	98.0	35.2	127.07	DC	90.03
157526575	341713	2KARGLE	69.0	EKPC	341287	2CENT HARDIN	69.0	EKPC	1	EKPC_P2-3_CHARD W124-804	bus	98.0	33.95	125.23	DC	89.45
157526824	341713	2KARGLE	69.0	EKPC	341287	2CENT HARDIN	69.0	EKPC	1	EKPC_P4-5_CHARD W124-848	breaker	98.0	35.2	127.07	DC	90.03
157526825	341713	2KARGLE	69.0	EKPC	341287	2CENT HARDIN	69.0	EKPC	1	EKPC_P4-2_CHARD W124-804	breaker	98.0	33.95	125.23	DC	89.45
157526826	341713	2KARGLE	69.0	EKPC	341287	2CENT HARDIN	69.0	EKPC	1	EKPC_P4-2_CHARD W124-814	breaker	98.0	31.54	122.82	DC	89.45
157526827	341713	2KARGLE	69.0	EKPC	341287	2CENT HARDIN	69.0	EKPC	1	EKPC_P4-6_CHARD W124-91T	breaker	98.0	31.44	122.71	DC	89.45
112349989	960170	AF2-308 TAP	69.0	EKPC	341287	2CENT HARDIN	69.0	EKPC	1	EKPC_P2-3_CHARD W124-814	bus	98.0	90.96	122.14	DC	30.55
157526550	960170	AF2-308 TAP	69.0	EKPC	341287	2CENT HARDIN	69.0	EKPC	1	EKPC_P2-3_CHARD W124-804	bus	98.0	90.96	122.14	DC	30.55
157526551	960170	AF2-308 TAP	69.0	EKPC	341287	2CENT HARDIN	69.0	EKPC	1	EKPC_P2-4_CHARD W124-91T	bus	98.0	90.96	122.14	DC	30.55
157526841	960170	AF2-308 TAP	69.0	EKPC	341287	2CENT HARDIN	69.0	EKPC	1	EKPC_P4-6_CHARD W124-91T	breaker	98.0	90.96	122.14	DC	30.55
157526842	960170	AF2-308 TAP	69.0	EKPC	341287	2CENT HARDIN	69.0	EKPC	1	EKPC_P4-2_CHARD W124-804	breaker	98.0	90.96	122.14	DC	30.55
157526843	960170	AF2-308 TAP	69.0	EKPC	341287	2CENT HARDIN	69.0	EKPC	1	EKPC_P4-2_CHARD W124-814	breaker	98.0	90.96	122.14	DC	30.55

ID	FROM BUS#	FROM BUS	kV	FROM BUS AREA	TO BUS#	TO BUS	kV	TO BUS AREA	CKT ID	CONT NAME	Type	Rating MVA	PRE PROJECT LOADING %	POST PROJECT LOADING %	AC DC	MW IMPACT
157526844	960170	AF2-308 TAP	69.0	EKPC	341287	2CENT HARDIN	69.0	EKPC	1	EKPC_P4-5_CHARD W124-848	breaker	98.0	87.21	117.79	DC	29.97

10.3 Contribution to Previously Identified Overloads

(This project contributes to the following contingency overloads, i.e. "Network Impacts", identified for earlier generation or transmission interconnection projects in the PJM Queue)

ID	FROM BUS#	FROM BUS	kV	FROM BUS AREA	TO BUS#	TO BUS	kV	TO BUS AREA	CKT ID	CONT NAME	Type	Rating MVA	PRE PROJECT LOADING %	POST PROJECT LOADING %	AC DC	MW IMPACT
98932084	324010	7TRIMBL REAC	345.0	LGEE	248000	06CLIFT Y	345.0	OVEC	1	AEP_P1-2_#363	single	1451.0	129.85	130.93	DC	15.61
98932088	324010	7TRIMBL REAC	345.0	LGEE	248000	06CLIFT Y	345.0	OVEC	1	Base Case	single	1134.0	114.02	115.38	DC	15.39
102045969	341287	2CENT HARDIN	69.0	EKPC	341713	2KARGL E	69.0	EKPC	1	EKPC_P1-2_CHARD - HARD138	single	98.0	148.25	189.96	DC	40.88
102045551	342307	2STEPHENSBRG	69.0	EKPC	342403	2UPTON T	69.0	EKPC	1	EKPC_P2-2_KU HODG 69	bus	39.0	107.85	117.51	DC	8.36
102045548	960170	AF2-308 TAP	69.0	EKPC	341287	2CENT HARDIN	69.0	EKPC	1	EKPC_P2-2_KU HODG 69	bus	98.0	118.24	135.17	DC	16.59

10.4 Potential Congestion due to Local Energy Deliverability

PJM also studied the delivery of the energy portion of this interconnection request. Any problems identified below are likely to result in operational restrictions to the project under study. The developer can proceed with network upgrades to eliminate the operational restriction at their discretion by submitting a Merchant Transmission Interconnection request.

Note: Only the most severely overloaded conditions are listed below. There is no guarantee of full delivery of energy for this project by fixing only the conditions listed in this section. With a Transmission Interconnection Request, a subsequent analysis will be performed which shall study all overload conditions associated with the overloaded element(s) identified.

ID	FROM BUS#	FROM BUS	kV	FROM BUS AREA	TO BUS#	TO BUS	kV	TO BUS AREA	CKT ID	CONT NAME	Type	Rating MVA	PRE PROJECT LOADING %	POST PROJECT LOADING %	AC DC	MW IMPACT
98932081	324010	7TRIMBL REAC	345.0	LGEE	248000	06CLIFT Y	345.0	OVEC	1	AEP_P1-2_#363	operation	1451.0	134.42	136.21	DC	26.02
98932087	324010	7TRIMBL REAC	345.0	LGEE	248000	06CLIFT Y	345.0	OVEC	1	Base Case	operation	1134.0	121.81	124.07	DC	25.66
102045968	341287	2CENT HARDIN	69.0	EKPC	341713	2KARGL E	69.0	EKPC	1	EKPC_P1-2_CHARD - HARD138	operation	98.0	184.7	254.22	DC	68.13
102045970	341287	2CENT HARDIN	69.0	EKPC	341713	2KARGL E	69.0	EKPC	1	Base Case	operation	89.0	102.99	160.16	DC	50.88

ID	FROM BUS#	FROM BUS	kV	FROM BUS AREA	TO BUS#	TO BUS	kV	TO BUS AREA	CKT ID	CONT NAME	Type	Rating MVA	PRE PROJECT LOADIN G %	POST PROJECT LOADIN G %	AC DC	MW IMPACT
102046286	342307	2STEPHENSBRG	69.0	EKPC	342403	2UPTONT	69.0	EKPC	1	EKPC_P1-2_C HAR-KU ETN69	operation	39.0	98.04	110.1	DC	10.44
102046288	342307	2STEPHENSBRG	69.0	EKPC	342403	2UPTONT	69.0	EKPC	1	Base Case	operation	35.0	91.73	100.81	DC	7.05
112823930	342568	4CENT HARDIN	138.0	EKPC	341287	2CENT HARDIN	69.0	EKPC	1	EKPC_P1-2_CHARD - HARD138	operation	175.0	92.62	109.03	DC	28.72
102046217	960170	AF2-308 TAP	69.0	EKPC	342307	2STEPHENSBRG	69.0	EKPC	1	EKPC_P1-2_C HAR-KU ETN69	operation	98.0	90.49	123.33	DC	32.18
102046220	960170	AF2-308 TAP	69.0	EKPC	342307	2STEPHENSBRG	69.0	EKPC	1	Base Case	operation	89.0	80.44	102.49	DC	19.62
102046348	960170	AF2-308 TAP	69.0	EKPC	341287	2CENT HARDIN	69.0	EKPC	1	Base Case	operation	89.0	96.94	118.98	DC	19.62
157526463	960170	AF2-308 TAP	69.0	EKPC	341287	2CENT HARDIN	69.0	EKPC	1	EKPC_P1-2_CHARD - HRDBG138	operation	98.0	90.7	111.88	DC	20.76

10.5 System Reinforcements - Summer Peak Load Flow - Primary POI

ID	Idx	Facility	Upgrade Description	Cost
102045548,112 349989,157526 843,157526842, 157526841,157 526844,157526 551,157526550	3	AF2-308 TAP 69.0 kV - 2CENT HARDIN 69.0 kV Ckt 1	<u>EKPC</u> EKPC-r0087 (1459) : Increase the maximum operating temperature of the 556 MCM ACSR conductor in the AF2-308 Tap-Central Hardin 69 kV line section to 302 degrees F (4.15 miles) Project Type : FAC Cost : \$280,000 Time Estimate : 9.0 Months	\$280,000
98932088,9893 2084	4	7TRIMBL REAC 345.0 kV - 06CLIFTY 345.0 kV Ckt 1	<u>LGEE</u> NonPJM Area (1634) : The external (i.e. Non-PJM) Transmission Owner, LGEE, will not evaluate this violation until the impact study phase. Project Type : FAC Cost : \$0 Time Estimate : N/A Months	\$0
157526825,157 526824,157526 827,157526826, 157526575,157 526574	2	2KARGLE 69.0 kV - 2CENT HARDIN 69.0 kV Ckt 1	<u>EKPC</u> EKPC-r0086b (1454) : Replace the 556 MCM ACSR jumpers at the Central Hardin substation using bundled 500 MCM copper or equivalent Project Type : FAC Cost : \$15,000 Time Estimate : 6.0 Months EKPC-r0086c (1455) : Rebuild the Central Hardin-Kargle 69 kV line section using 954 MCM ACSS conductor at 392 degrees F (0.6 miles) Project Type : FAC Cost : \$450,000 Time Estimate : 12.0 Months	\$465,000

ID	Idx	Facility	Upgrade Description	Cost
102045974,102045969	1	2CENT HARDIN 69.0 kV - 2KARGLE 69.0 kV Ckt 1	<p>EKPC EKPC-r0086a (1480) : Increase the maximum operating temperature of the 556 MCM ACSR conductor in the Central Hardin-Kargle 69 kV line section to 302 degrees F (0.6 miles) Project Type : FAC Cost : \$40,000 Time Estimate : 6.0 Months</p> <p>EKPC-r0086b (1481) : Replace the 556 MCM ACSR jumpers at the Central Hardin substation using bundled 500 MCM copper or equivalent Project Type : FAC Cost : \$15,000 Time Estimate : 6.0 Months</p> <p>EKPC-r0086c (1482) : Rebuild the Central Hardin-Kargle 69 kV line section using 954 MCM ACSS conductor at 392 degrees F (0.6 miles) Project Type : FAC Cost : \$450,000 Time Estimate : 12.0 Months</p> <p>EKPC-r0086d (1483) : Change the Zone 3 relay setting at Central Hardin associated with the line protection to at least 190 MVA LTE rating. Project Type : FAC Cost : \$0 Time Estimate : 6.0 Months</p> <p>EKPC-r0086e (1484) : Replace the 750 MCM ACSR jumpers at the Central Hardin substation using bundled 500 MCM copper or equivalent Project Type : FAC Cost : \$15,000 Time Estimate : 6.0 Months</p> <p>EKPC-r0086f (1485) : Replace the 1200A disconnect switches W124-623 and W124-625 at Central Hardin substation and W80-605 at the Kargle tap location.. Project Type : FAC Cost : \$300,000 Time Estimate : 12.0 Months</p>	\$780,000
102045551	5	2STEPHENSBRG 69.0 kV - 2UPTON T 69.0 kV Ckt 1	<p>EKPC EKPC-r0089 (1488) : Increase the maximum operating temperature of the 4/0 ACSR conductor in the Stephensburg-Upton Tap 69 kV line section to 212 degrees F (10.75 miles) Project Type : FAC Cost : \$730,000 Time Estimate : 18.0 Months</p>	\$730,000
			TOTAL COST	\$1,790,000

10.6 Flow Gate Details - Primary POI

The following indices contain additional information about each facility presented in the body of the report. For each index, a description of the flowgate and its contingency was included for convenience. The intent of the indices is to provide more details on which projects/generators have contributions to the flowgate in question. All New Service Queue Requests, through the end of the Queue under study, that are contributors to a flowgate will be listed in the indices. Please note that there may be contributors that are subsequently queued after the queue under study that are not listed in the indices. Although this information is not used "as is" for cost allocation purposes, it can be used to gage the impact of other projects/generators. It should be noted the project/generator MW contributions presented in the body of the report are Full MW Impact contributions which are also noted in the indices column named "Full MW Impact", whereas the loading percentages reported in the body of the report, take into consideration the PJM Generator Deliverability Test rules such as commercial probability of each project as well as the ramping impact of "Adder" contributions. The MW Impact found and used in the analysis is shown in the indices column named "Gendeliv MW Impact".

10.6.1 Index 1

ID	FROM BUS#	FROM BUS	FROM BUS AREA	TO BUS#	TO BUS	TO BUS AREA	CKT ID	CONT NAME	Type	Rating MVA	PRE PROJECT LOADING %	POST PROJECT LOADING %	AC DC	MW IMPACT
102045969	341287	2CENT HARDIN	EKPC	341713	2KARGLE	EKPC	1	EKPC_P1-2_CHARD-HARD138	single	98.0	148.25	189.96	DC	40.88

Bus #	Bus	Gendeliv MW Impact	Type	Full MW Impact
952821	J762	13.4600	PJM External (MISO)	13.4600
957961	AF2-090 C	29.7580	80/20	29.7580
959691	AF2-260 C O1	19.1730	80/20	19.1730
960171	AF2-308	11.7765	80/20	11.7765
960181	AF2-309 C	17.6648	80/20	17.6648
960741	AF2-365 C O1	1.6191	80/20	1.6191
961001	AF2-391 C O1	40.8773	80/20	40.8773
WEC	WEC	0.0438	Confirmed LTF	0.0438
CPLE	CPLE	0.0814	Confirmed LTF	0.0814
CBM-W2	CBM-W2	3.5708	Confirmed LTF	3.5708
NY	NY	0.0061	Confirmed LTF	0.0061
CBM-W1	CBM-W1	1.5387	Confirmed LTF	1.5387
TVA	TVA	0.7840	Confirmed LTF	0.7840
CBM-S2	CBM-S2	0.9768	Confirmed LTF	0.9768
CBM-S1	CBM-S1	2.8457	Confirmed LTF	2.8457
MADISON	MADISON	0.8588	Confirmed LTF	0.8588
MEC	MEC	0.4147	Confirmed LTF	0.4147
BLUEG	BLUEG	1.1024	Confirmed LTF	1.1024
TRIMBLE	TRIMBLE	0.3066	Confirmed LTF	0.3066

10.6.2 Index 2

ID	FROM BUS#	FROM BUS	FROM BUS AREA	TO BUS#	TO BUS	TO BUS AREA	CKT ID	CONT NAME	Type	Rating MVA	PRE PROJECT LOADING %	POST PROJECT LOADING %	AC DC	MW IMPACT
157526824	341713	2KARGLE	EKPC	341287	2CENT HARDIN	EKPC	1	EKPC_P4-5_CHARD W124-848	breaker	98.0	35.2	127.07	DC	90.03

Bus #	Bus	Gendeliv MW Impact	Type	Full MW Impact
960172	AF2-308 BAT	15.8222	50/50	15.8222
961003	AF2-391 BAT	90.0300	50/50	90.0300
LGEE	LGEE	0.1877	Confirmed LTF	0.1877
NEWTON	NEWTON	0.0312	Confirmed LTF	0.0312
FARMERCITY	FARMERCITY	0.0062	Confirmed LTF	0.0062
CALDERWOOD	CALDERWOOD	0.1287	Confirmed LTF	0.1287
NY	NY	0.0028	Confirmed LTF	0.0028
PRAIRIE	PRAIRIE	0.3642	Confirmed LTF	0.3642
O-066	O-066	0.0672	Confirmed LTF	0.0672
CHEOAH	CHEOAH	0.1276	Confirmed LTF	0.1276
EDWARDS	EDWARDS	0.0042	Confirmed LTF	0.0042
G-007	G-007	0.0104	Confirmed LTF	0.0104
CATAWBA	CATAWBA	0.0473	Confirmed LTF	0.0473

10.6.3 Index 3

ID	FROM BUS#	FROM BUS	FROM BUS AREA	TO BUS#	TO BUS	TO BUS AREA	CKT ID	CONT NAME	Type	Rating MVA	PRE PROJECT LOADING %	POST PROJECT LOADING %	AC DC	MW IMPACT
102045548	960170	AF2-308 TAP	EKPC	341287	2CENT HARDIN	EKPC	1	EKPC_P2-2_KU HODG 69	bus	98.0	118.24	135.17	DC	16.59

Bus #	Bus	Gendeliv MW Impact	Type	Full MW Impact
959691	AF2-260 C O1	36.8184	50/50	36.8184
959692	AF2-260 E O1	18.4092	50/50	18.4092
960171	AF2-308	20.0096	50/50	20.0096
960181	AF2-309 C	30.0145	50/50	30.0145
960182	AF2-309 E	20.0096	50/50	20.0096
960741	AF2-365 C O1	3.3723	50/50	3.3723
960742	AF2-365 E O1	2.2482	50/50	2.2482
961003	AF2-391 BAT	16.5936	50/50	16.5936
WEC	WEC	0.0079	Confirmed LTF	0.0079
CPL	CPL	0.0880	Confirmed LTF	0.0880
G-007A	G-007A	0.0240	Confirmed LTF	0.0240
VFT	VFT	0.0645	Confirmed LTF	0.0645
CBM-W2	CBM-W2	1.8018	Confirmed LTF	1.8018
CBM-W1	CBM-W1	0.3378	Confirmed LTF	0.3378
TVA	TVA	0.6342	Confirmed LTF	0.6342
CBM-S2	CBM-S2	1.0057	Confirmed LTF	1.0057
CBM-S1	CBM-S1	2.4623	Confirmed LTF	2.4623
TILTON	TILTON	0.0189	Confirmed LTF	0.0189
MADISON	MADISON	0.4778	Confirmed LTF	0.4778
MEC	MEC	0.1891	Confirmed LTF	0.1891
GIBSON	GIBSON	0.0513	Confirmed LTF	0.0513
BLUEG	BLUEG	0.8802	Confirmed LTF	0.8802
TRIMBLE	TRIMBLE	0.2460	Confirmed LTF	0.2460

10.6.4 Index 4

ID	FROM BUS#	FROM BUS	FROM BUS AREA	TO BUS#	TO BUS	TO BUS AREA	CKT ID	CONT NAME	Type	Rating MVA	PRE PROJECT LOADING %	POST PROJECT LOADING %	AC DC	MW IMPACT
98932084	324010	7TRIMBL REAC	LGEE	248000	06CLIFTY	OVEC	1	AEP_P1-2_#363	single	1451.0	129.85	130.93	DC	15.61

Bus #	Bus	Gendeliv MW Impact	Type	Full MW Impact
243442	05RKG1	14.5062	80/20	14.5062
243443	05RKG2	14.2864	80/20	14.2864
342900	1COOPER1 G	2.4207	80/20	2.4207
342903	1COOPER2 G	4.6942	80/20	4.6942
342918	1JKCT 1G	1.8896	80/20	1.8896
342921	1JKCT 2G	1.3706	80/20	1.3706
342924	1JKCT 3G	1.8896	80/20	1.8896
342927	1JKCT 4G	1.2540	80/20	1.2540
342930	1JKCT 5G	1.2472	80/20	1.2472
342933	1JKCT 6G	1.2540	80/20	1.2540
342936	1JKCT 7G	1.2540	80/20	1.2540
342939	1JKCT 9G	1.2895	80/20	1.2895
342942	1JKCT 10G	1.2895	80/20	1.2895
342945	1LAUREL 1G	1.3659	80/20	1.3659
925981	AC1-074 C O1	3.9855	80/20	3.9855
930461	AB1-087	35.0735	80/20	35.0735
930471	AB1-088	35.0735	80/20	35.0735
932551	AC2-075 C	0.9466	80/20	0.9466
933441	AC2-157 C	4.8465	80/20	4.8465
936381	AD2-048 C	3.4301	80/20	3.4301
936571	AD2-072 C O1	10.1176	80/20	10.1176
939131	AE1-143 C	9.5735	80/20	9.5735
940041	AE1-246 C O1	11.9517	80/20	11.9517
940831	AE2-071 C	3.0314	80/20	3.0314
941341	AE2-130 C	30.5808	80/20	30.5808
941411	AE2-138 C	15.1422	80/20	15.1422
941981	AE2-210 C O1	5.2176	80/20	5.2176
942411	AE2-254 C O1	4.0278	80/20	4.0278
942591	AE2-275 C O1	6.8134	80/20	6.8134
942601	AE2-276	3.1885	80/20	3.1885
942891	AE2-308 C O1	11.5071	80/20	11.5071
943111	AE2-339 C	2.5623	80/20	2.5623
943701	AF1-038 C	4.6588	80/20	4.6588
943821	AF1-050 C	5.4126	80/20	5.4126
944151	AF1-083 C O1	4.9790	80/20	4.9790
944201	AF1-088 FTIR	63.7700	80/20	63.7700
944511	AF1-116 C	10.7366	80/20	10.7366
944621	AF1-127 C O1	4.4322	80/20	4.4322
945381	AF1-203 C	1.7322	80/20	1.7322
945541	AF1-219 C O1	3.2077	80/20	3.2077
945861	AF1-251 C	10.7144	80/20	10.7144
946021	AF1-267 C	3.8151	80/20	3.8151

Bus #	Bus	Gendeliv MW Impact	Type	Full MW Impact
952811	J759	9.7391	PJM External (MISO)	9.7391
952821	J762	30.0320	PJM External (MISO)	30.0320
952861	J783 C	9.3334	PJM External (MISO)	9.3334
953611	J800	14.1350	PJM External (MISO)	14.1350
953931	J856	9.4496	PJM External (MISO)	9.4496
955451	J1027	13.7985	PJM External (MISO)	13.7985
955461	J1028	15.2805	PJM External (MISO)	15.2805
955891	J1074	23.0880	PJM External (MISO)	23.0880
956911	J1189	0.4479	PJM External (MISO)	0.4479
957141	AF2-008 FTIR	31.8850	80/20	31.8850
957961	AF2-090 C	16.4592	80/20	16.4592
959691	AF2-260 C O1	11.9778	80/20	11.9778
960151	AF2-306	1.6749	80/20	1.6749
960161	AF2-307 C	2.5510	80/20	2.5510
960171	AF2-308	5.7854	80/20	5.7854
960181	AF2-309 C	8.6780	80/20	8.6780
960621	AF2-353 C	35.6776	80/20	35.6776
960641	AF2-355 C O1	15.1214	80/20	15.1214
960741	AF2-365 C O1	4.7367	80/20	4.7367
961001	AF2-391 C O1	15.6096	80/20	15.6096
961281	AF2-419 C	1.8240	80/20	1.8240
961291	AF2-420 C	1.8240	80/20	1.8240
WEC	WEC	0.6634	Confirmed LTF	0.6634
LGEE	LGEE	18.1402	Confirmed LTF	18.1402
CPL	CPL	1.1986	Confirmed LTF	1.1986
CBM-W2	CBM-W2	56.1670	Confirmed LTF	56.1670
NY	NY	0.2737	Confirmed LTF	0.2737
CBM-W1	CBM-W1	19.6532	Confirmed LTF	19.6532
TVA	TVA	9.5130	Confirmed LTF	9.5130
CBM-S2	CBM-S2	14.7563	Confirmed LTF	14.7563
CBM-S1	CBM-S1	97.4858	Confirmed LTF	97.4858
MADISON	MADISON	12.3480	Confirmed LTF	12.3480
MEC	MEC	6.0890	Confirmed LTF	6.0890

10.6.5 Index 5

ID	FROM BUS#	FROM BUS	FROM BUS AREA	TO BUS#	TO BUS	TO BUS AREA	CKT ID	CONT NAME	Type	Rating MVA	PRE PROJECT LOADING %	POST PROJECT LOADING %	AC DC	MW IMPACT
102045551	342307	2STEPHENSBRG	EKPC	342403	2UPTON T	EKPC	1	EKPC_P2-2_KU HODG 69	bus	39.0	107.85	117.51	DC	8.36

Bus #	Bus	Gendeliv MW Impact	Type	Full MW Impact
959691	AF2-260 C O1	11.8140	50/50	11.8140
959692	AF2-260 E O1	5.9070	50/50	5.9070
960171	AF2-308	4.0634	50/50	4.0634
960181	AF2-309 C	6.0950	50/50	6.0950
960182	AF2-309 E	4.0634	50/50	4.0634
961001	AF2-391 C O1	2.2608	Adder	5.02
961002	AF2-391 E O1	1.5072	Adder	3.35
WEC	WEC	0.0063	Confirmed LTF	0.0063
LGEE	LGEE	0.1090	Confirmed LTF	0.1090
FARMERCITY	FARMERCITY	0.0021	Confirmed LTF	0.0021
CALDERWOOD	CALDERWOOD	0.1004	Confirmed LTF	0.1004
NY	NY	0.0044	Confirmed LTF	0.0044
CBM-W1	CBM-W1	0.1751	Confirmed LTF	0.1751
PRAIRIE	PRAIRIE	0.1007	Confirmed LTF	0.1007
O-066	O-066	0.0739	Confirmed LTF	0.0739
CHEOAH	CHEOAH	0.0991	Confirmed LTF	0.0991
G-007	G-007	0.0114	Confirmed LTF	0.0114
CATAWBA	CATAWBA	0.0350	Confirmed LTF	0.0350

10.7 Queue Dependencies

The Queue Projects below are listed in one or more indices for the overloads identified in your report. These projects contribute to the loading of the overloaded facilities identified in your report. The percent overload of a facility and cost allocation you may have towards a particular reinforcement could vary depending on the action of these earlier projects. The status of each project at the time of the analysis is presented in the table. This list may change as earlier projects withdraw or modify their requests.

Queue Number	Project Name	Status
AB1-087	Sullivan 345kV #1	Active
AB1-088	Sullivan 345kV #2	Active
AC1-074	Jacksonville-Renaker 138kV I	Active
AC2-075	Great Blue Heron Solar	Active
AC2-157	Sullivan 345 kV	Active
AD2-048	Cynthia-Headquarters 69 kV	Active
AD2-072	Van Arsdell-Mercer Industrial 69kV	Active
AE1-143	Marion County 161 kV	Active
AE1-246	Barren County-Summer Shade 161 kV	Active
AE2-071	Patton Rd-Summer Shade 69 kV	Active
AE2-130	Rockport 765 kV	Active
AE2-138	Avon-North Clark 345 kV	Active
AE2-210	Avon-North Clark 345 kV	Active
AE2-254	Garrard County-Tommy-Gooch 69 kV	Active
AE2-275	JK Smith-Fawkes 138 kV	Active
AE2-276	Sullivan 345kV	Active
AE2-308	Three Forks-Dale 138 kV	Active
AE2-339	Avon 138 kV	Active
AF1-038	Sewellton Jct-Webbs Crossroads 69 kV	Active
AF1-050	Summer Shade - Green County 161 kV	Active
AF1-083	Green County-Saloma 161 kV	Active
AF1-088	Sullivan 345 kV	Active
AF1-116	Marion County 161 kV	Active
AF1-127	Avon 345 kV	Active
AF1-203	Patton Rd-Summer Shade 69 kV	Active
AF1-219	Hunt Farm 69 kV	Active
AF1-251	Avon-North Clark 345 kV	Active
AF1-267	Union City Tap 138 kV	Active
AF2-008	Sullivan 345 kV	Active
AF2-090	Central Hardin 138 kV	Active
AF2-260	Stephensburg 69 kV	Active
AF2-306	Hope-Blevins Valley Tap 69 kV	Active
AF2-307	Hope-Blevins Valley Tap 69 kV	Active
AF2-308	Central Hardin-Stephensburg 69 kV	Active
AF2-309	Central Hardin-Stephensburg 69 kV	Active
AF2-353	Rockport 765 kV	Active
AF2-355	West Gerrard-J.K. Smith 345 nKV	Active
AF2-365	Munfordville KU Tap-Horse Cave Jct. 69 kV	Active
AF2-391	Central Hardin 69 kV	Active

Queue Number	Project Name	Status
AF2-419	Hunt Farm-Ballard 69 kV	Active
AF2-420	Hunt Farm-Ballard 69 kV	Active
J1027	MISO	MISO
J1028	MISO	MISO
J1074	MISO	MISO
J1189	MISO	MISO
J759	MISO	MISO
J762	MISO	MISO
J783	MISO	MISO
J800	MISO	MISO
J856	MISO	MISO

10.8 Contingency Descriptions - Primary POI

Contingency Name	Contingency Definition
EKPC_P4-2_CHARD W124-814	CONTINGENCY 'EKPC_P4-2_CHARD W124-814' /* CENTRAL HARDIN OPEN BRANCH FROM BUS 341287 TO BUS 342568 CKT 1 /* 341287 2CENT HARDIN69.000 342568 4CENT HARDIN138.00 OPEN BRANCH FROM BUS 324261 TO BUS 342568 CKT 1 /* 324261 4HARDN 138.00 342568 4CENT HARDIN138.00 END
EKPC_P2-4_CHARD W124-91T	CONTINGENCY 'EKPC_P2-4_CHARD W124-91T' /* CENTRAL HARDIN OPEN BRANCH FROM BUS 324047 TO BUS 342568 CKT 1 /* 324047 4BLACKBRNCH 138.00 342568 4CENT HARDIN138.00 OPEN BRANCH FROM BUS 324047 TO BUS 324260 CKT 1 /* 324047 4BLACKBRNCH 138.00 324260 4HARDBG 138.00 OPEN BRANCH FROM BUS 324261 TO BUS 342568 CKT 1 /* 324261 4HARDN 138.00 342568 4CENT HARDIN138.00 END
EKPC_P4-2_CHARD W124-804	CONTINGENCY 'EKPC_P4-2_CHARD W124-804' /* CENTRAL HARDIN OPEN BRANCH FROM BUS 341287 TO BUS 342568 CKT 1 /* 341287 2CENT HARDIN69.000 342568 4CENT HARDIN138.00 OPEN BRANCH FROM BUS 324047 TO BUS 342568 CKT 1 /* 324047 4BLACKBRNCH 138.00 342568 4CENT HARDIN138.00 OPEN BRANCH FROM BUS 324047 TO BUS 324260 CKT 1 /* 324047 4BLACKBRNCH 138.00 324260 4HARDBG 138.00 END
AEP_P1-2_#363	CONTINGENCY 'AEP_P1-2_#363' OPEN BRANCH FROM BUS 243208 TO BUS 243209 CKT 1 / 243208 05JEFRSO 765 243209 05ROCKPT 765 1 END
EKPC_P2-3_CHARD W124-814	CONTINGENCY 'EKPC_P2-3_CHARD W124-814' /* CENTRAL HARDIN OPEN BRANCH FROM BUS 341287 TO BUS 342568 CKT 1 /* 341287 2CENT HARDIN69.000 342568 4CENT HARDIN138.00 OPEN BRANCH FROM BUS 324261 TO BUS 342568 CKT 1 /* 324261 4HARDN 138.00 342568 4CENT HARDIN138.00 END
EKPC_P1-2_CHARD-HRDBG138	CONTINGENCY 'EKPC_P1-2_CHARD-HRDBG138' /* CENTRAL HARDIN - HARDINSBURG OPEN BRANCH FROM BUS 324047 TO BUS 342568 CKT 1 /* 324047 4BLACKBRNCH 138.00 342568 4CENT HARDIN138.00 OPEN BRANCH FROM BUS 324047 TO BUS 324260 CKT 1 /* 324047 4BLACKBRNCH 138.00 324260 4HARDBG 138.00 END

Contingency Name	Contingency Definition
EKPC_P2-3_CHARD W124-804	CONTINGENCY 'EKPC_P2-3_CHARD W124-804' /* CENTRAL HARDIN OPEN BRANCH FROM BUS 341287 TO BUS 342568 CKT 1 /* 341287 2CENT HARDIN69.000 342568 4CENT HARDIN138.00 OPEN BRANCH FROM BUS 324047 TO BUS 342568 CKT 1 /* 324047 4BLACKBRNCH 138.00 342568 4CENT HARDIN138.00 OPEN BRANCH FROM BUS 324047 TO BUS 324260 CKT 1 /* 324047 4BLACKBRNCH 138.00 324260 4HARDBG 138.00 END
EKPC_P4-5_CHARD W124-848	CONTINGENCY 'EKPC_P4-5_CHARD W124-848' /* CENTRAL HARDIN OPEN BRANCH FROM BUS 341287 TO BUS 342568 CKT 1 /* 341287 2CENT HARDIN69.000 342568 4CENT HARDIN138.00 END
EKPC_P1-2_CHARD-HARD138	CONTINGENCY 'EKPC_P1-2_CHARD-HARD138' /* CENTRAL HARDIN - KU HARDIN OPEN BRANCH FROM BUS 324261 TO BUS 342568 CKT 1 /* 324261 4HARDN 138.00 342568 4CENT HARDIN138.00 END
EKPC_P2-2_CENT HARD 138	CONTINGENCY 'EKPC_P2-2_CENT HARD 138' /* CENTRAL HARDIN 138 BUS OPEN BRANCH FROM BUS 341287 TO BUS 342568 CKT 1 /* 341287 2CENT HARDIN69.000 342568 4CENT HARDIN138.00 END
Base Case	
EKPC_P4-6_CHARD W124-91T	CONTINGENCY 'EKPC_P4-6_CHARD W124-91T' /* CENTRAL HARDIN OPEN BRANCH FROM BUS 324047 TO BUS 342568 CKT 1 /* 324047 4BLACKBRNCH 138.00 342568 4CENT HARDIN138.00 OPEN BRANCH FROM BUS 324047 TO BUS 324260 CKT 1 /* 324047 4BLACKBRNCH 138.00 324260 4HARDBG 138.00 OPEN BRANCH FROM BUS 324261 TO BUS 342568 CKT 1 /* 324261 4HARDN 138.00 342568 4CENT HARDIN138.00 END
EKPC_P1-2_C HAR-KU ETN69	CONTINGENCY 'EKPC_P1-2_C HAR-KU ETN69' /* CENTRAL HARDIN - KU ETOWN OPEN BRANCH FROM BUS 341287 TO BUS 341713 CKT 1 /* 341287 2CENT HARDIN69.000 341713 2KARGLE 69.000 OPEN BRANCH FROM BUS 324519 TO BUS 341713 CKT 1 /* 324519 2ETOWN KU 69.000 341713 2KARGLE 69.000 END
EKPC_P2-2_KU HODG 69	CONTINGENCY 'EKPC_P2-2_KU HODG 69' /* KU HODGENVILLE 69 TIE OPEN BUS 341632 /* 2HODGENVILLE END

11 Light Load Analysis

Light Load Studies (As applicable)

To be determined during later study phases.

12 Short Circuit Analysis – Primary POI

The following Breakers are overdutied:

To be determined during later study phases.

13 Stability and Reactive Power Assessment

(Summary of the VAR requirements based upon the results of the dynamic studies)

To be determined during later study phases.

14 Affected Systems

14.1 LG&E

LG&E Impacts to be determined during later study phases (as applicable).

14.2 MISO

MISO Impacts to be determined during later study phases (as applicable).

14.3 TVA

TVA Impacts to be determined during later study phases (as applicable).

14.4 Duke Energy Progress

Duke Energy Progress Impacts to be determined during later study phases (as applicable).

15 Summer Peak - Load Flow Analysis - Secondary POI

The Queue Project AF2-391 was evaluated as a 120.0 MW (Capacity 72.0 MW) injection tapping the Central Hardin to Stephensburg 69 kV line in the EKPC area. Project AF2-391 was evaluated for compliance with applicable reliability planning criteria (PJM, NERC, NERC Regional Reliability Councils, and Transmission Owners). Project AF2-391 was studied with a commercial probability of 53.0 %. Potential network impacts were as follows:

15.1 Generation Deliverability

(Single or N-1 contingencies for the Capacity portion only of the interconnection)

ID	FROM BUS#	FROM BUS	kV	FROM BUS AREA	TO BUS#	TO BUS	kV	TO BUS AREA	CK T ID	CONT NAME	Type	Rating MVA	PRE PROJECT LOADIN G %	POST PROJECT LOADIN G %	AC D C	MW IMPACT
102045974	341287	2CENT HARDIN	69.0	EKPC	341713	2KARGLE	69.0	EKPC	1	Base Case	single	89.0	91.98	121.43	DC	26.22
153570637	959690	AF2-260 TAP	69.0	EKPC	342307	2STEPHENSBRG	69.0	EKPC	1	EKPC_P1-2_CHARD - HARD138	single	98.0	96.82	118.68	DC	21.42
153570638	959690	AF2-260 TAP	69.0	EKPC	342307	2STEPHENSBRG	69.0	EKPC	1	Base Case	single	89.0	96.59	118.57	DC	19.57
153570809	960170	AF2-308 TAP	69.0	EKPC	959690	AF2-260 TAP	69.0	EKPC	1	EKPC_P1-2_CHARD - KU ETN69	single	98.0	79.48	106.05	DC	26.04
153570549	961000	AF2-391 TAP	69.0	EKPC	341287	2CENT HARDIN	69.0	EKPC	1	Base Case	single	89.0	71.42	130.34	DC	52.43
153570550	961000	AF2-391 TAP	69.0	EKPC	341287	2CENT HARDIN	69.0	EKPC	1	EKPC_P1-2_STEPH-KUEAST69	single	98.0	64.52	121.53	DC	55.88

15.2 Multiple Facility Contingency

(Double Circuit Tower Line, Fault with a Stuck Breaker, and Bus Fault contingencies for the full energy output)

ID	FROM BUS#	FROM BUS	kV	FROM BUS AREA	TO BUS#	TO BUS	kV	TO BUS AREA	CK T ID	CONT NAME	Type	Rating MVA	PRE PROJECT LOADIN G %	POST PROJECT LOADIN G %	AC D C	MW IMPACT
102045551	342307	2STEPHENSBRG	69.0	EKPC	342403	2UPTO NT	69.0	EKPC	1	EKPC_P2-2_KU HODG 69	bus	39.0	97.67	131.41	DC	13.16

15.3 Contribution to Previously Identified Overloads

(This project contributes to the following contingency overloads, i.e. "Network Impacts", identified for earlier generation or transmission interconnection projects in the PJM Queue)

ID	FROM BUS#	FROM BUS	kV	FROM BUS AREA	TO BUS#	TO BUS	kV	TO BUS AREA	CK T ID	CONT NAME	Type	Rating MVA	PRE PROJECT LOADIN G %	POST PROJECT LOADIN G %	AC D C	MW IMPACT
98932084	324010	7TRIMBL REAC	345.0	LGEE	248000	06CLIFTY	345.0	OVEC	1	AEP_P1-2_#363	single	1451.0	129.83	130.88	DC	15.22
98932085	324010	7TRIMBL REAC	345.0	LGEE	248000	06CLIFTY	345.0	OVEC	1	AEP_P1-2_#10136	single	1451.0	124.25	125.31	DC	15.25
98932088	324010	7TRIMBL REAC	345.0	LGEE	248000	06CLIFTY	345.0	OVEC	1	Base Case	single	1134.0	114.0	115.33	DC	15.0
102045969	341287	2CENT HARDIN	69.0	EKPC	341713	2KARGLE	69.0	EKPC	1	EKPC_P1-2_CHARD - HARD138	single	98.0	154.74	190.72	DC	35.26
153090128	341287	2CENT HARDIN	69.0	EKPC	341713	2KARGLE	69.0	EKPC	1	EKPC_P2-4_CHARD W124-91T	bus	98.0	189.42	268.73	DC	77.72

ID	FROM BUS#	FROM BUS	kV	FROM BUS AREA	TO BUS#	TO BUS	kV	TO BUS AREA	CK T ID	CONT NAME	Type	Rating MVA	PRE PROJECT LOADIN G %	POST PROJECT LOADIN G %	AC D C	MW IMPAC T
100346027	341713	2KARGL E	69.0	EKPC	324519	2ETOWN KU	69.0	LGEE	1	EKPC_P1-2_CHAR D-HARD138	single	76.0	180.98	227.37	DC	35.26
100346032	341713	2KARGL E	69.0	EKPC	324519	2ETOWN KU	69.0	LGEE	1	Base Case	single	66.0	102.66	142.38	DC	26.22
153570636	959690	AF2-260 TAP	69.0	EKPC	342307	2STEPHENSBR G	69.0	EKPC	1	EKPC_P1-2_C HAR-KU ETN69	single	98.0	107.69	134.26	DC	26.04
153090108	961000	AF2-391 TAP	69.0	EKPC	341287	2CENT HARDIN	69.0	EKPC	1	EKPC_P2-2_STEPB G 69	bus	98.0	191.73	314.18	DC	120.0
153090109	961000	AF2-391 TAP	69.0	EKPC	341287	2CENT HARDIN	69.0	EKPC	1	EKPC_P2-2_KU HODG 69	bus	98.0	130.32	226.3	DC	94.05

15.4 Potential Congestion due to Local Energy Deliverability

PJM also studied the delivery of the energy portion of this interconnection request. Any problems identified below are likely to result in operational restrictions to the project under study. The developer can proceed with network upgrades to eliminate the operational restriction at their discretion by submitting a Merchant Transmission Interconnection request.

Note: Only the most severely overloaded conditions are listed below. There is no guarantee of full delivery of energy for this project by fixing only the conditions listed in this section. With a Transmission Interconnection Request, a subsequent analysis will be performed which shall study all overload conditions associated with the overloaded element(s) identified.

ID	FROM BUS#	FROM BUS	kV	FROM BUS AREA	TO BUS#	TO BUS	kV	TO BUS AREA	CK T ID	CONT NAME	Type	Rating MVA	PRE PROJEC T LOADIN G %	POST PROJEC T LOADIN G %	AC D C	MW IMPAC T
98932081	324010	7TRIMBL REAC	345.0	LGEE	248000	06CLIFTY	345.0	OVE C	1	AEP_P1-2_#363	operatio n	1451.0	134.37	136.12	DC	25.37
98932087	324010	7TRIMBL REAC	345.0	LGEE	248000	06CLIFTY	345.0	OVE C	1	Base Case	operatio n	1134.0	121.76	123.96	DC	25.0
102045968	341287	2CENT HARDIN	69.0	EKPC	341713	2KARGLE	69.0	EKP C	1	EKPC_P1-2_CHAR D-HARD138	operatio n	98.0	193.52	253.49	DC	58.77
102045970	341287	2CENT HARDIN	69.0	EKPC	341713	2KARGLE	69.0	EKP C	1	Base Case	operatio n	89.0	111.31	160.4	DC	43.69
102046346	341533	2GLENDALE	69.0	EKPC	341632	2HODGENVIL LE	69.0	EKP C	1	EKPC_P1-2_C HAR-KU ETN69	operatio n	66.0	85.6	110.18	DC	16.22
100346026	341713	2KARGLE	69.0	EKPC	324519	2ETOWN KU	69.0	LGE E	1	EKPC_P1-2_CHAR D-HARD138	operatio n	76.0	230.99	308.32	DC	58.77
100346028	341713	2KARGLE	69.0	EKPC	324519	2ETOWN KU	69.0	LGE E	1	Base Case	operatio n	66.0	128.74	194.94	DC	43.69

ID	FROM BUS#	FROM BUS	kV	FRO M BUS AREA	TO BUS#	TO BUS	kV	TO BUS AREA	CK T ID	CONT NAME	Type	Ratin g MVA	PRE PROJEC T LOADIN G %	POST PROJEC T LOADIN G %	AC D C	MW IMPAC T
102046286	342307	2STEPHENSBRG	69.0	EKPC	342403	2UPTON T	69.0	EKP C	1	EKPC_P1-2_C HAR-KU ETN69	operatio n	39.0	90.94	126.3	DC	13.79
100346320	342568	4CENT HARDIN	138.0	EKPC	324261	4HARDIN CO	138.0	LGE E	1	EKPC_P1-2_C HAR-KU ETN69	operatio n	265.0	93.75	117.17	DC	62.06
153570631	959690	AF2-260 TAP	69.0	EKPC	342307	2STEPHENSBRG	69.0	EKP C	1	EKPC_P1-2_C HAR-KU ETN69	operatio n	98.0	132.95	177.24	DC	43.4
153570633	959690	AF2-260 TAP	69.0	EKPC	342307	2STEPHENSBRG	69.0	EKP C	1	Base Case	operatio n	89.0	119.73	156.37	DC	32.61
153570804	960170	AF2-308 TAP	69.0	EKPC	959690	AF2-260 TAP	69.0	EKP C	1	EKPC_P1-2_C HAR-KU ETN69	operatio n	98.0	90.59	134.87	DC	43.4
153570806	960170	AF2-308 TAP	69.0	EKPC	959690	AF2-260 TAP	69.0	EKP C	1	Base Case	operatio n	89.0	80.56	117.2	DC	32.61
153570544	961000	AF2-391 TAP	69.0	EKPC	341287	2CENT HARDIN	69.0	EKP C	1	Base Case	operatio n	89.0	115.51	213.7	DC	87.39
153570545	961000	AF2-391 TAP	69.0	EKPC	341287	2CENT HARDIN	69.0	EKP C	1	EKPC_P1-2_STEPH - KUEAST69	operatio n	98.0	108.39	203.42	DC	93.13
153571012	961000	AF2-391 TAP	69.0	EKPC	960170	AF2-308 TAP	69.0	EKP C	1	EKPC_P1-2_C HAR-KU ETN69	operatio n	98.0	62.01	106.29	DC	43.4

15.5 Flow Gate Details - Secondary POI

The following indices contain additional information about each facility presented in the body of the report. For each index, a description of the flowgate and its contingency was included for convenience. The intent of the indices is to provide more details on which projects/generators have contributions to the flowgate in question. All New Service Queue Requests, through the end of the Queue under study, that are contributors to a flowgate will be listed in the indices. Please note that there may be contributors that are subsequently queued after the queue under study that are not listed in the indices. Although this information is not used "as is" for cost allocation purposes, it can be used to gage the impact of other projects/generators. It should be noted the project/generator MW contributions presented in the body of the report are Full MW Impact contributions which are also noted in the indices column named "Full MW Impact", whereas the loading percentages reported in the body of the report, take into consideration the PJM Generator Deliverability Test rules such as commercial probability of each project as well as the ramping impact of "Adder" contributions. The MW Impact found and used in the analysis is shown in the indices column named "Gendeliv MW Impact".

15.5.1 Index 1

ID	FROM BUS#	FROM BUS	FROM BUS AREA	TO BUS#	TO BUS	TO BUS AREA	CKT ID	CONT NAME	Type	Rating MVA	PRE PROJECT LOADING %	POST PROJECT LOADING %	AC DC	MW IMPACT
153090128	341287	2CENT HARDIN	EKPC	341713	2KARGLE	EKPC	1	EKPC_P2-4_CHARD W124-91T	bus	98.0	189.42	268.73	DC	77.72

Bus #	Bus	Gendeliv MW Impact	Type	Full MW Impact
957961	AF2-090 C	54.8614	50/50	54.8614
957962	AF2-090 E	27.1326	50/50	27.1326
959691	AF2-260 C O2	32.5398	50/50	32.5398
959692	AF2-260 E O2	16.2699	50/50	16.2699
960171	AF2-308	15.7094	50/50	15.7094
960181	AF2-309 C	23.5641	50/50	23.5641
960182	AF2-309 E	15.7094	50/50	15.7094
960741	AF2-365 C O2	4.1397	50/50	4.1397
960742	AF2-365 E O2	2.7598	50/50	2.7598
961001	AF2-391 C O2	46.6337	50/50	46.6337
961002	AF2-391 E O2	31.0891	50/50	31.0891
WEC	WEC	0.0069	Confirmed LTF	0.0069
CPL	CPL	0.0728	Confirmed LTF	0.0728
G-007A	G-007A	0.0192	Confirmed LTF	0.0192
VFT	VFT	0.0516	Confirmed LTF	0.0516
CBM-W2	CBM-W2	1.5315	Confirmed LTF	1.5315
CBM-W1	CBM-W1	0.3002	Confirmed LTF	0.3002
TVA	TVA	0.5264	Confirmed LTF	0.5264
CBM-S2	CBM-S2	0.8323	Confirmed LTF	0.8323
CBM-S1	CBM-S1	2.0192	Confirmed LTF	2.0192
TILTON	TILTON	0.0132	Confirmed LTF	0.0132
MADISON	MADISON	0.4012	Confirmed LTF	0.4012
MEC	MEC	0.1589	Confirmed LTF	0.1589
GIBSON	GIBSON	0.0349	Confirmed LTF	0.0349
BLUEG	BLUEG	0.7673	Confirmed LTF	0.7673
TRIMBLE	TRIMBLE	0.2137	Confirmed LTF	0.2137

15.5.2 Index 2

ID	FROM BUS#	FROM BUS	FROM BUS AREA	TO BUS#	TO BUS	TO BUS AREA	CKT ID	CONT NAME	Type	Rating MVA	PRE PROJECT LOADING %	POST PROJECT LOADING %	AC DC	MW IMPACT
153570636	959690	AF2-260 TAP	EKPC	342307	2STEPHENSBRG	EKPC	1	EKPC_P1-2_CHAR-KU ETN69	single	98.0	107.69	134.26	DC	26.04

Bus #	Bus	Gendeliv MW Impact	Type	Full MW Impact
957961	AF2-090 C	5.0482	80/20	5.0482
959691	AF2-260 C O2	27.7452	80/20	27.7452
960171	AF2-308	12.4463	80/20	12.4463
960181	AF2-309 C	18.6694	80/20	18.6694
961001	AF2-391 C O2	26.0381	80/20	26.0381
WEC	WEC	0.0013	Confirmed LTF	0.0013
LGEE	LGEE	0.1820	Confirmed LTF	0.1820
NEWTON	NEWTON	0.0043	Confirmed LTF	0.0043
FARMERCITY	FARMERCITY	0.0053	Confirmed LTF	0.0053
CALDERWOOD	CALDERWOOD	0.1342	Confirmed LTF	0.1342
NY	NY	0.0044	Confirmed LTF	0.0044
PRAIRIE	PRAIRIE	0.3100	Confirmed LTF	0.3100
CHEOAH	CHEOAH	0.1326	Confirmed LTF	0.1326
CATAWBA	CATAWBA	0.0486	Confirmed LTF	0.0486

15.5.3 Index 3

ID	FROM BUS#	FROM BUS	FROM BUS AREA	TO BUS#	TO BUS	TO BUS AREA	CKT ID	CONT NAME	Type	Rating MVA	PRE PROJECT LOADING %	POST PROJECT LOADING %	AC DC	MW IMPACT
153570809	960170	AF2-308 TAP	EKPC	959690	AF2-260 TAP	EKPC	1	EKPC_P1-2_CHAR-KU ETN69	single	98.0	79.48	106.05	DC	26.04

Bus #	Bus	Gendeliv MW Impact	Type	Full MW Impact
957961	AF2-090 C	5.0482	80/20	5.0482
960171	AF2-308	12.4463	80/20	12.4463
960181	AF2-309 C	18.6694	80/20	18.6694
961001	AF2-391 C O2	26.0381	80/20	26.0381
WEC	WEC	0.0013	Confirmed LTF	0.0013
LGEE	LGEE	0.1820	Confirmed LTF	0.1820
NEWTON	NEWTON	0.0043	Confirmed LTF	0.0043
FARMERCITY	FARMERCITY	0.0053	Confirmed LTF	0.0053
CALDERWOOD	CALDERWOOD	0.1342	Confirmed LTF	0.1342
NY	NY	0.0044	Confirmed LTF	0.0044
PRAIRIE	PRAIRIE	0.3100	Confirmed LTF	0.3100
CHEOAH	CHEOAH	0.1326	Confirmed LTF	0.1326
CATAWBA	CATAWBA	0.0486	Confirmed LTF	0.0486

15.5.4 Index 4

ID	FROM BUS#	FROM BUS	FROM BUS AREA	TO BUS#	TO BUS	TO BUS AREA	CKT ID	CONT NAME	Type	Rating MVA	PRE PROJECT LOADING %	POST PROJECT LOADING %	AC DC	MW IMPACT
153090108	961000	AF2-391 TAP	EKPC	341287	2CENT HARDIN	EKPC	1	EKPC_P2-2_STEPBG 69	bus	98.0	191.73	314.18	DC	120.0

Bus #	Bus	Gendeliv MW Impact	Type	Full MW Impact
959691	AF2-260 C O2	60.0000	50/50	60.0000
959692	AF2-260 E O2	30.0000	50/50	30.0000
960171	AF2-308	28.0000	50/50	28.0000
960181	AF2-309 C	42.0000	50/50	42.0000
960182	AF2-309 E	28.0000	50/50	28.0000
961001	AF2-391 C O2	72.0000	50/50	72.0000
961002	AF2-391 E O2	48.0000	50/50	48.0000

15.5.5 Index 5

ID	FROM BUS#	FROM BUS	FROM BUS AREA	TO BUS#	TO BUS	TO BUS AREA	CKT ID	CONT NAME	Type	Rating MVA	PRE PROJECT LOADING %	POST PROJECT LOADING %	AC DC	MW IMPACT
102045551	342307	2STEPHENSBRG	EKPC	342403	2UPTON T	EKPC	1	EKPC_P2-2_KU HODG 69	bus	39.0	97.67	131.41	DC	13.16

Bus #	Bus	Gendeliv MW Impact	Type	Full MW Impact
959691	AF2-260 C O2	9.1668	50/50	9.1668
959692	AF2-260 E O2	4.5834	50/50	4.5834
960171	AF2-308	4.0634	50/50	4.0634
960181	AF2-309 C	6.0950	50/50	6.0950
960182	AF2-309 E	4.0634	50/50	4.0634
961001	AF2-391 C O2	7.8962	50/50	7.8962
961002	AF2-391 E O2	5.2642	50/50	5.2642
WEC	WEC	0.0063	Confirmed LTF	0.0063
LGEE	LGEE	0.1090	Confirmed LTF	0.1090
FARMERCITY	FARMERCITY	0.0021	Confirmed LTF	0.0021
CALDERWOOD	CALDERWOOD	0.1004	Confirmed LTF	0.1004
NY	NY	0.0044	Confirmed LTF	0.0044
CBM-W1	CBM-W1	0.1751	Confirmed LTF	0.1751
PRAIRIE	PRAIRIE	0.1007	Confirmed LTF	0.1007
O-066	O-066	0.0739	Confirmed LTF	0.0739
CHEOAH	CHEOAH	0.0991	Confirmed LTF	0.0991
G-007	G-007	0.0114	Confirmed LTF	0.0114
CATAWBA	CATAWBA	0.0350	Confirmed LTF	0.0350

15.5.6 Index 6

ID	FROM BUS#	FROM BUS	FROM BUS AREA	TO BUS#	TO BUS	TO BUS AREA	CKT ID	CONT NAME	Type	Rating MVA	PRE PROJECT LOADING %	POST PROJECT LOADING %	AC DC	MW IMPACT
98932084	324010	7TRIMBL REAC	LGEE	248000	06CLIFTY	OVEC	1	AEP_P1-2_#363	single	1451.0	129.83	130.88	DC	15.22

Bus #	Bus	Gendeliv MW Impact	Type	Full MW Impact
243442	05RKG1	14.5062	80/20	14.5062
243443	05RKG2	14.2864	80/20	14.2864
342900	1COOPER1 G	2.4207	80/20	2.4207
342903	1COOPER2 G	4.6942	80/20	4.6942
342918	1JKCT 1G	1.8896	80/20	1.8896
342921	1JKCT 2G	1.3706	80/20	1.3706
342924	1JKCT 3G	1.8896	80/20	1.8896
342927	1JKCT 4G	1.2540	80/20	1.2540
342930	1JKCT 5G	1.2472	80/20	1.2472
342933	1JKCT 6G	1.2540	80/20	1.2540
342936	1JKCT 7G	1.2540	80/20	1.2540
342939	1JKCT 9G	1.2895	80/20	1.2895
342942	1JKCT 10G	1.2895	80/20	1.2895
342945	1LAUREL 1G	1.3659	80/20	1.3659
925981	AC1-074 C O1	3.9855	80/20	3.9855
930461	AB1-087	35.0735	80/20	35.0735
930471	AB1-088	35.0735	80/20	35.0735
932551	AC2-075 C	0.9466	80/20	0.9466
933441	AC2-157 C	4.8465	80/20	4.8465
936381	AD2-048 C	3.4301	80/20	3.4301
936571	AD2-072 C O1	10.1176	80/20	10.1176
939131	AE1-143 C	9.5735	80/20	9.5735
940041	AE1-246 C O1	11.9517	80/20	11.9517
940831	AE2-071 C	3.0314	80/20	3.0314
941341	AE2-130 C	30.5808	80/20	30.5808
941411	AE2-138 C	15.1422	80/20	15.1422
941981	AE2-210 C O1	5.2176	80/20	5.2176
942411	AE2-254 C O1	4.0278	80/20	4.0278
942591	AE2-275 C O1	6.8134	80/20	6.8134
942601	AE2-276	3.1885	80/20	3.1885
942891	AE2-308 C O1	11.5071	80/20	11.5071
943111	AE2-339 C	2.5623	80/20	2.5623
943701	AF1-038 C	4.6588	80/20	4.6588
943821	AF1-050 C	5.4126	80/20	5.4126
944151	AF1-083 C O1	4.9790	80/20	4.9790
944201	AF1-088 FTIR	63.7700	80/20	63.7700
944511	AF1-116 C	10.7366	80/20	10.7366
944621	AF1-127 C O1	4.4322	80/20	4.4322
945381	AF1-203 C	1.7322	80/20	1.7322
945541	AF1-219 C O1	3.2077	80/20	3.2077
945861	AF1-251 C	10.7144	80/20	10.7144
946021	AF1-267 C	3.8151	80/20	3.8151

Bus #	Bus	Gendeliv MW Impact	Type	Full MW Impact
952811	J759	9.7391	PJM External (MISO)	9.7391
952821	J762	30.0320	PJM External (MISO)	30.0320
952861	J783 C	9.3334	PJM External (MISO)	9.3334
953611	J800	14.1350	PJM External (MISO)	14.1350
953931	J856	9.4496	PJM External (MISO)	9.4496
955451	J1027	13.7985	PJM External (MISO)	13.7985
955461	J1028	15.2805	PJM External (MISO)	15.2805
955891	J1074	23.0880	PJM External (MISO)	23.0880
956911	J1189	0.4479	PJM External (MISO)	0.4479
957141	AF2-008 FTIR	31.8850	80/20	31.8850
957961	AF2-090 C	16.4592	80/20	16.4592
959691	AF2-260 C O2	12.3348	80/20	12.3348
960151	AF2-306	1.6749	80/20	1.6749
960161	AF2-307 C	2.5510	80/20	2.5510
960171	AF2-308	5.7854	80/20	5.7854
960181	AF2-309 C	8.6780	80/20	8.6780
960621	AF2-353 C	35.6776	80/20	35.6776
960641	AF2-355 C O2	14.1574	80/20	14.1574
960741	AF2-365 C O2	5.1087	80/20	5.1087
961001	AF2-391 C O2	15.2215	80/20	15.2215
961281	AF2-419 C	1.8240	80/20	1.8240
961291	AF2-420 C	1.8240	80/20	1.8240
WEC	WEC	0.6634	Confirmed LTF	0.6634
LGEE	LGEE	18.1402	Confirmed LTF	18.1402
CPL	CPL	1.1986	Confirmed LTF	1.1986
CBM-W2	CBM-W2	56.1670	Confirmed LTF	56.1670
NY	NY	0.2737	Confirmed LTF	0.2737
CBM-W1	CBM-W1	19.6657	Confirmed LTF	19.6657
TVA	TVA	9.5130	Confirmed LTF	9.5130
CBM-S2	CBM-S2	14.7563	Confirmed LTF	14.7563
CBM-S1	CBM-S1	97.4858	Confirmed LTF	97.4858
MADISON	MADISON	12.3480	Confirmed LTF	12.3480
MEC	MEC	6.0890	Confirmed LTF	6.0890

15.5.7 Index 7

ID	FROM BUS#	FROM BUS	FROM BUS AREA	TO BUS#	TO BUS	TO BUS AREA	CKT ID	CONT NAME	Type	Rating MVA	PRE PROJECT LOADING %	POST PROJECT LOADING %	AC DC	MW IMPACT
100346027	341713	2KARGLE	EKPC	324519	2ETOWN KU	LGEE	1	EKPC_P1- 2_CHAR- HARD138	single	76.0	180.98	227.37	DC	35.26

Bus #	Bus	Gendeliv MW Impact	Type	Full MW Impact
952821	J762	13.4600	PJM External (MISO)	13.4600
957961	AF2-090 C	29.7580	80/20	29.7580
959691	AF2-260 C O2	24.3390	80/20	24.3390
960171	AF2-308	11.7765	80/20	11.7765
960181	AF2-309 C	17.6648	80/20	17.6648
960741	AF2-365 C O2	2.8143	80/20	2.8143
961001	AF2-391 C O2	35.2620	80/20	35.2620
WEC	WEC	0.0438	Confirmed LTF	0.0438
CPLE	CPLE	0.0814	Confirmed LTF	0.0814
CBM-W2	CBM-W2	3.5708	Confirmed LTF	3.5708
NY	NY	0.0061	Confirmed LTF	0.0061
CBM-W1	CBM-W1	1.5387	Confirmed LTF	1.5387
TVA	TVA	0.7840	Confirmed LTF	0.7840
CBM-S2	CBM-S2	0.9768	Confirmed LTF	0.9768
CBM-S1	CBM-S1	2.8457	Confirmed LTF	2.8457
MADISON	MADISON	0.8588	Confirmed LTF	0.8588
MEC	MEC	0.4147	Confirmed LTF	0.4147
BLUEG	BLUEG	1.1024	Confirmed LTF	1.1024
TRIMBLE	TRIMBLE	0.3066	Confirmed LTF	0.3066

15.6 Contingency Descriptions - Secondary POI

Contingency Name	Contingency Definition
EKPC_P2-4_CHARD W124-91T	CONTINGENCY 'EKPC_P2-4_CHARD W124-91T' /* CENTRAL HARDIN OPEN BRANCH FROM BUS 324047 TO BUS 342568 CKT 1 /* 324047 4BLACKBRNCH 138.00 342568 4CENT HARDIN138.00 OPEN BRANCH FROM BUS 324047 TO BUS 324260 CKT 1 /* 324047 4BLACKBRNCH 138.00 324260 4HARDBG 138.00 OPEN BRANCH FROM BUS 324261 TO BUS 342568 CKT 1 /* 324261 4HARDN 138.00 342568 4CENT HARDIN138.00 END
EKPC_P1-2_STEPH-KUEAST69	CONTINGENCY 'EKPC_P1-2_STEPH-KUEAST69' /* STEPHENSBURG - KU EASTVIEW OPEN BRANCH FROM BUS 324509 TO BUS 342307 CKT 1 /* 324509 2EASTVW 69.000 342307 2STEPHNSBRG69.000 END
EKPC_P2-2_STEPBG 69	CONTINGENCY 'EKPC_P2-2_STEPBG 69' /* STEPHENSBURG 69 BUS OPEN BUS 342307 /* 2STEPHNSBRG END
EKPC_P1-2_CHARD-HARD138	CONTINGENCY 'EKPC_P1-2_CHARD-HARD138' /* CENTRAL HARDIN - KU HARDIN OPEN BRANCH FROM BUS 324261 TO BUS 342568 CKT 1 /* 324261 4HARDN 138.00 342568 4CENT HARDIN138.00 END
AEP_P1-2_#10136	CONTINGENCY 'AEP_P1-2_#10136' OPEN BRANCH FROM BUS 243208 TO BUS 243209 CKT 1 / 243208 05JEFRSO 765 243209 05ROCKPT 765 1 OPEN BRANCH FROM BUS 243209 TO BUS 243443 CKT 2 / 243209 05ROCKPT 765 243443 05RKG2 26.0 2 REMOVE UNIT 2H FROM BUS 243443 / 243443 05RKG2 26.0 REMOVE UNIT 2L FROM BUS 243443 / 243443 05RKG2 26.0 END
AEP_P1-2_#363	CONTINGENCY 'AEP_P1-2_#363' OPEN BRANCH FROM BUS 243208 TO BUS 243209 CKT 1 / 243208 05JEFRSO 765 243209 05ROCKPT 765 1 END
Base Case	

Contingency Name	Contingency Definition
EKPC_P1-2_C HAR-KU ETN69	CONTINGENCY 'EKPC_P1-2_C HAR-KU ETN69' /* CENTRAL HARDIN - KU ETOWN OPEN BRANCH FROM BUS 341287 TO BUS 341713 CKT 1 /* 341287 2CENT HARDIN69.000 341713 2KARGLE 69.000 OPEN BRANCH FROM BUS 324519 TO BUS 341713 CKT 1 /* 324519 2ETOWN KU 69.000 341713 2KARGLE 69.000 END
EKPC_P2-2_KU HODG 69	CONTINGENCY 'EKPC_P2-2_KU HODG 69' /* KU HODGENVILLE 69 TIE OPEN BUS 341632 /* 2HODGENVILLE END

16 Light Load Analysis – Secondary POI

Light Load Studies (As applicable)

To be determined during later study phases.

17 Short Circuit Analysis – Secondary POI

The following Breakers are overdutied:

To be determined during later study phases.

18 Stability and Reactive Power Assessment – Secondary POI

(Summary of the VAR requirements based upon the results of the dynamic studies)

To be determined during later study phases.

19 Affected Systems – Secondary POI

19.1 LG&E

LG&E Impacts to be determined during later study phases (as applicable).

19.2 MISO

MISO Impacts to be determined during later study phases (as applicable).

19.3 TVA

TVA Impacts to be determined during later study phases (as applicable).

19.4 Duke Energy Progress

Duke Energy Progress Impacts to be determined during later study phases (as applicable).

20 Attachment 1: One Line Diagram

AF2-391 Conceptual Single-Line Diagram of Interconnection Facilities

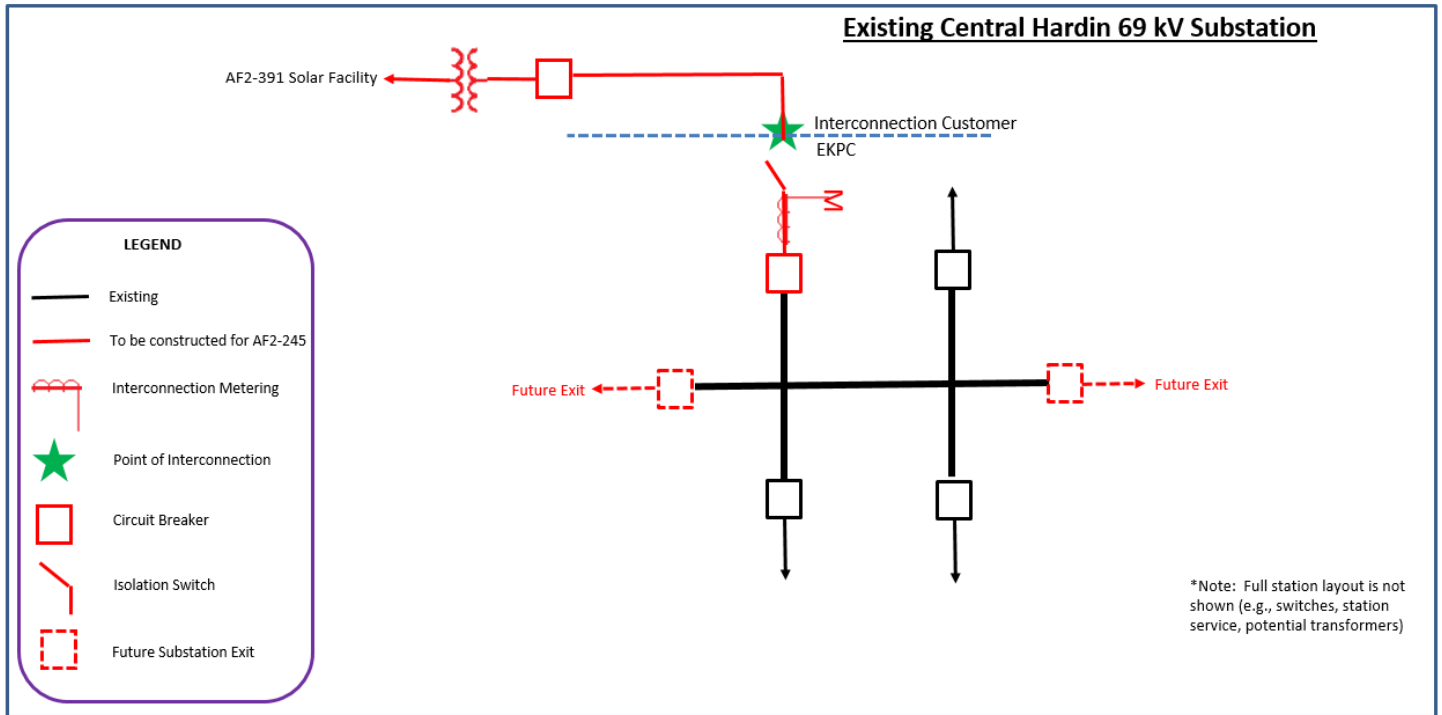

EXHIBIT E

Economic Impact of Stonefield Solar Project



Report was prepared for Candela Renewables under contract with Stantec.

December 2021

SER

Strategic
Economic
Research, LLC

by David G. Loomis
Strategic Economic Research, LLC
strategieconomic.com
815-905-2750

About the Author



Dr. David G. Loomis

Professor of Economics, Illinois State University
Co-Founder of the Center for Renewable Energy
President of Strategic Economic Research, LLC

Dr. David G. Loomis is Professor of Economics at Illinois State University and Co-Founder of the Center for Renewable Energy. He has over 10 years of experience in the renewable energy field and has performed economic analyses at the county, region, state and national levels for utility-scale wind and solar generation. He has served as a consultant for Apex Clean Energy, Clean Line Energy Partners, EDF Renewables, E.ON Climate and Renewables, Geronimo Energy, Invenergy, J-Power, the National Renewable Energy Laboratories, Ranger Power, State of Illinois, Tradewind, and others. He has testified on the economic impacts of energy projects before the Illinois Commerce Commission, Iowa Utilities Board, Missouri Public Service Commission, Illinois Senate Energy and Environment Committee, the Wisconsin Public Service Commission, Kentucky Public Service Commission, Ohio Public Siting Board, and numerous county boards. Dr. Loomis is a widely recognized expert and has been quoted in the Wall Street Journal, Forbes Magazine, Associated Press, and Chicago Tribune as well as appearing on CNN.

Dr. Loomis has published over 38 peer-reviewed articles in leading energy policy and economics journals. He has raised and managed over \$7 million in grants and contracts from government, corporate and foundation sources. He received the 2011 Department of Energy's Midwestern Regional Wind Advocacy Award and the 2006 Best Wind Working Group Award. Dr. Loomis received his Ph.D. in economics from Temple University in 1995.

Strategic Economic Research, LLC

Strategic Economic Research, LLC (SER) has produced over 150 economic impact reports in 28 states for renewable energy projects across the US. SER specializes in economic analysis at the county, regional, state or national levels to analyze the jobs, income, taxes and economic output that will flow from a particular industry.

Research Associates

Bryan Loomis, MBA, Vice President

Ethan Loomis, Director of Marketing

Madison Schneider, Project Manager

Christopher Thankan, Economic Analyst

Zoe Calio, Project Manager

Patrick Chen, Property Tax Analysis

Kathryn Keithley, Property Tax Analysis

Morgan Stong, Data Specialist

David Whitworth, Data Specialist

SER

Strategic
Economic
Research, LLC

Table of Contents

- I. Executive Summary of Findings1
- II. U.S. Solar PV Industry Growth and Economic Development 2
 - a. U.S. Solar PV Industry Growth..... 2
 - b. Kentucky Solar PV Industry 4
 - c. Economic Benefits of Utility-Scale Solar PV Energy 6
- III. Project Description and Location 8
 - a. Stonefield Solar Project 8
 - b. Hardin County, Kentucky..... 8
 - i. Economic and Demographic Statistics 9
 - ii. Agricultural Statistics 11
- IV. Economic Impact Methodology12
- V. Economic Impact Results..... 14
- VI. Tax Revenue17
- VII. Conclusion20
- VIII. References.....21
- IX. Curriculum Vita - David G. Loomis..... 24



Table of Contents - Figures & Tables

Figure 1 – Annual U.S. Solar PV Installations, 2010-2026E 2

Figure 2 – U.S. Annual Solar PV Installed Price Trends Over Time..... 2

Figure 3 – U.S. Utility PV Installations vs. Contracted Pipeline 3

Figure 4 – Solar Company Locations in Kentucky 4

Figure 5 – Kentucky Annual Solar Installations. 5

Figure 6 – Electric Generation Employment by Technology 5

Figure 7 – Location of Hardin County, Kentucky 8

Figure 8 – Total Employment in Hardin County from 2007 to 2019 9

Figure 9 – Population in Hardin County from 2010 to 2019 10

Figure 10 – Median Household Income in Hardin County from 2010 to 2019 10

Figure 11 – Real Gross Domestic Product (GDP) in Hardin County from 2010 to 2019..... 10

Figure 12 – Number of Farms in Hardin County from 1992 to 2017 11

Figure 13 – Land in Farms in Hardin County from 1992 to 2017 11

Table 1 – Employment by Industry in Hardin County..... 9

Table 2 – Total Employment Impact from Stonefield Solar Project 14

Table 3 – Total Earnings Impact from Stonefield Solar Project..... 16

Table 4 – Total Output Impact from Stonefield Solar Project..... 16

Table 5 – Total Property Taxes Paid by Stonefield Solar Project..... 19

I. Executive Summary of Findings

Candela Renewables is developing the Stonefield Solar Project in Hardin County, Kentucky. The purpose of this report is to aid decision makers in evaluating the economic impact of this project on Hardin County and the Commonwealth of Kentucky. The basis of this analysis is to study the direct, indirect, and induced impacts on job creation, wages, and total economic output.

Stonefield Solar Project is a 120-megawatt alternating current (MWac) utility-scale solar powered-electric generation facility that will utilize photovoltaic (PV) panels installed on a single-axis tracking system. Solar power electric generation facilities are commonly referred to as PV systems or solar PV. The Project represents an investment in excess of \$114 million. The total development is anticipated to result in the following:

Economic Impact of the Stonefield Solar Project, Hardin County, KY

Jobs – all jobs numbers are full-time equivalents

- Over 93 new local jobs during construction for Hardin County
- Over 209 new local jobs during construction for the Commonwealth of Kentucky
- Over 7.6 new local long-term jobs for Hardin County
- Over 9.9 new local long-term jobs for the Commonwealth of Kentucky

Earnings

- Over \$6.5 million in new local earnings during construction for Hardin County
- Over \$14 million in new local earnings during construction for the Commonwealth of Kentucky
- Over \$290 thousand in new local long-term earnings for Hardin County annually
- Over \$503 thousand in new local long-term earnings for the Commonwealth of Kentucky annually

Output

- Over \$8 million in new local output during construction for Hardin County
- Over \$21 million in new local output during construction for the Commonwealth of Kentucky
- Over \$1 million in new local long-term output for Hardin County annually
- Over \$1.5 million in new local long-term output for the Commonwealth of Kentucky

Property Taxes

- Over \$2.4 million in total school district revenue over the life of the Project
- Over \$626 thousand in total county property taxes for Hardin County over the life of the Project
- Over \$6.7 million in property taxes in total for all taxing districts over the life of the Project

II. U.S. Solar PV Industry Growth and Economic Development

a. U.S. Solar PV Industry Growth

The U.S. solar industry is growing at a rapid but uneven pace, with systems installed for onsite use, including residential, commercial and industrial properties and with utility-scale solar powered-electric generation facilities intended for wholesale distribution, such as Stonefield Solar. From 2013 to 2018, the amount of electricity generated from solar had more than quadrupled, increasing 444%. (SEIA, 2020). The industry has continued to add increasing numbers of PV systems to the grid. In the first half of 2021, the U.S. installed over 11,000 MW direct current (MWdc) of solar PV driven mostly by utility-scale PV which exceeds most of the annual installations in the last decade. Figure 1 shows the historical capacity additions as well as the forecasted additions into 2026. The primary driver of this overall sharp pace of growth is large price declines in solar equipment. The overall price of solar PV has declined from \$5.79/watt in 2010 to \$1.33/watt in 2020 (SEIA, 2020). According to Figure 2, utility-scale solar fixed tilt and single-axis tracking have declined from \$1.50/watt at the beginning of 2015 to near \$1.00/watt by the first quarter of 2021. Solar PV also benefits from the Federal Investment Tax Credit (ITC) which provides a 26 percent tax credit for residential and commercial properties.

Figure 1 – Annual U.S. Solar PV Installations, 2010-2026E

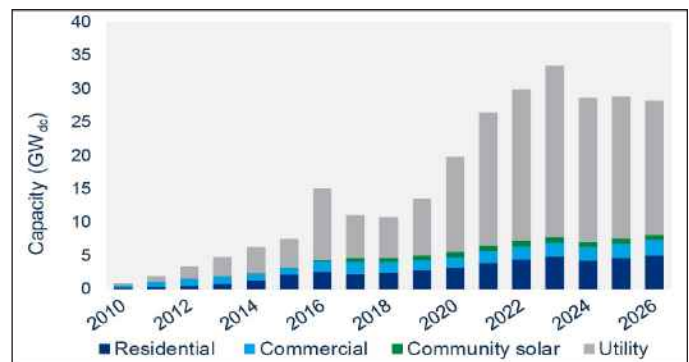

Source: Solar Energy Industries Association, Solar Market Insight Report Q3 2021

Figure 2 – U.S. Annual Solar PV Installed Price Trends Over Time

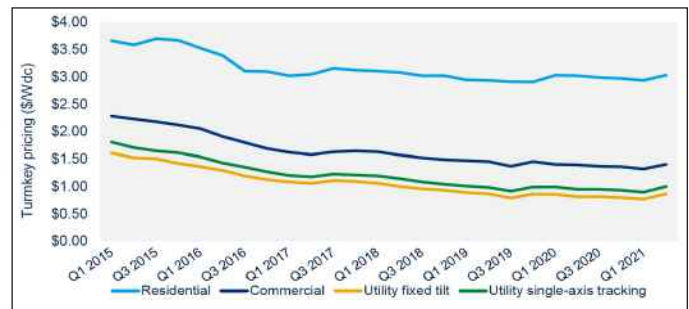

Source: Solar Energy Industries Association, Solar Market Insight Report Q3 2021

Utility-scale PV leads the installation growth in the U.S. A total of 19,200 MWdc of utility PV projects were completed in 2020. According to Figure 3, there are 85,000 MWdc of contracted utility-scale installations that have not been built yet.

Figure 3 – U.S. Utility PV Installations vs. Contracted Pipeline

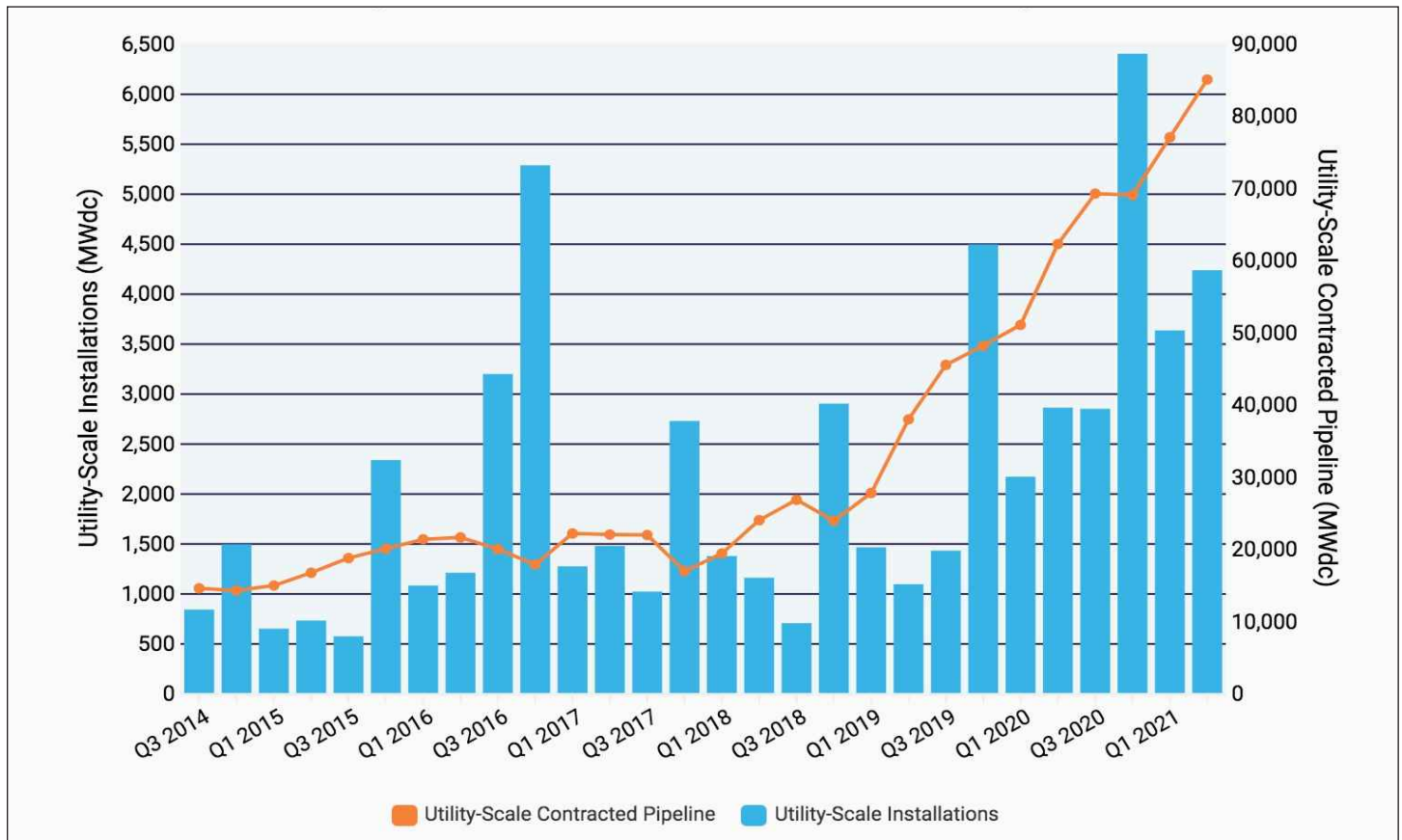

Source: Solar Energy Industries Association, Solar Market Insight Report 2021 Q2

b. Kentucky Solar PV Industry

According to SEIA (2021), Kentucky is ranked 47th in the U.S. in cumulative installations of solar PV. California, Texas, and Florida are the top 3 states for solar PV which may not be surprising because of the high solar irradiation that they receive. However, other states with similar solar irradiation to Kentucky rank highly including New Jersey (7th), Massachusetts (8th), New York (10th), and Maryland (17th). In 2020, Kentucky installed 5.73 MW of solar electric capacity bringing its cumulative capacity to 64.41 MW.

Kentucky has great potential to expand its solar installations. Kentucky has three utility-scale solar farms in operation: Cooperative Solar Farm One is an 8.5 MW installation in Winchester, KY; General Motors has installed a 0.85 MW project at its location in Bowling Green, KY; and Crittenden Solar Facility is a 2MW installation in Grant County, KY. The 120 MW Stonefield Solar Project will be one of the largest installations in Kentucky to date.

There are more than 51 solar companies in Kentucky including 14 manufacturers, 19 installers/developers, and 18 others.¹ Figure 4 shows the locations of solar companies in Kentucky as of the time of this report. Currently, there are 1,249 solar jobs in the Commonwealth of Kentucky according to SEIA (2021).

Figure 4 – Solar Company Locations in Kentucky

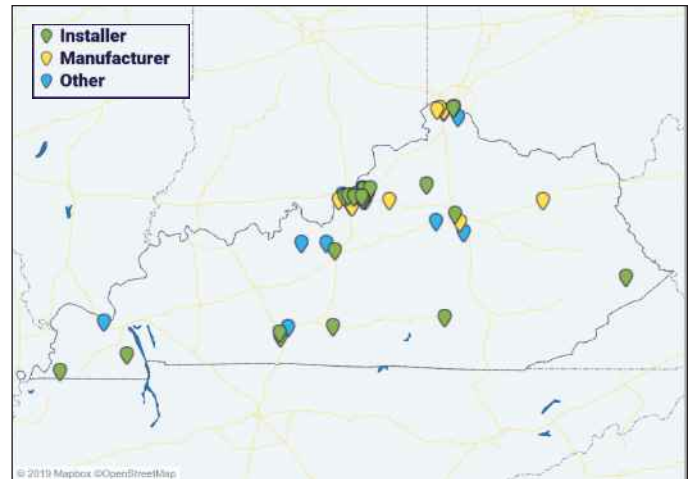

Solar Energy Industries Association, Solar Spotlight: Kentucky, 2021

Figure 5 shows the Kentucky historical installed capacity by year according to SEIA (2021). Huge growth was seen in 2017 and is forecasted to continue to grow in 2021 and beyond. Over the next five years, solar in Kentucky is projected to grow by 814.76 MW.

The U.S. Department of Energy sponsors the U.S. Energy and Employment Report each year. Electric Power Generation covers all utility and non-utility employment across electric generating technologies, including fossil fuels, nuclear, and renewable technologies. It also includes employees engaged in facility construction, turbine and other generation equipment manufacturing, operations and maintenance, and wholesale parts distribution for all electric generation technologies. According to Figure 6, employment in the solar energy industry (1,745) trails behind coal electric generation (1,790) but is larger than natural gas generation (688) and wind electric generation (166). (U.S. Department of Energy. (2020))

Figure 5 – Kentucky Annual Solar Installations

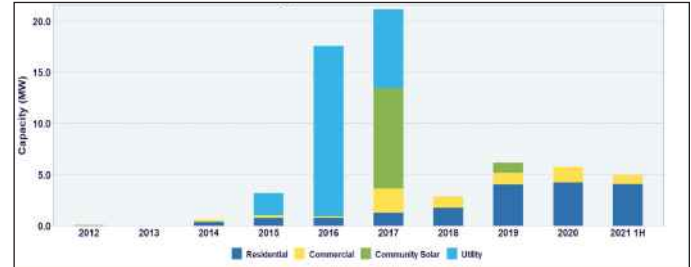

Source: Solar Energy Industries Association, Solar Spotlight: Kentucky, 2021

Figure 6 – Electric Generation Employment by Technology

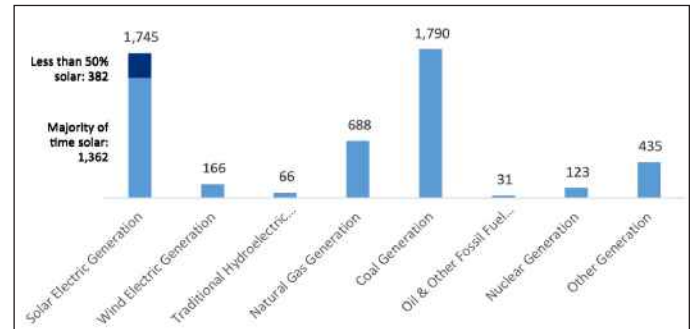

Source: US Energy and Employment Report 2020: Kentucky

c. Economic Benefits of Utility-Scale Solar PV Energy

Utility-scale solar powered-electric generation facilities have numerous economic benefits. Solar PV installations create job opportunities in the local area during both the short-term construction phase and the long-term operational phase. In addition to the workers directly involved in the construction and maintenance of the solar energy project, numerous other jobs are supported through indirect supply chain purchases and the higher spending that is induced by these workers. Solar PV projects strengthen the local tax base and help improve county services, and local infrastructure, such as public roads.

Numerous studies have quantified the economic benefits of Solar PV projects across the United States and have been published in peer-reviewed academic journals using the same methodology as this report. Some of these studies examine smaller-scale solar systems, and some examine utility-scale solar energy. Croucher (2012) uses NREL's Jobs and Economic Development Impacts ("JEDI") modeling methodology to find which state will receive the greatest economic impact from installing one hundred 2.5 kW residential systems. He shows that Pennsylvania ranked first supporting 28.98 jobs during installation and 0.20 jobs during operations. Illinois ranked second supporting 27.65 jobs during construction and 0.18 jobs during operations.

Jo et. al. (2016) analyzes the financing options and economic impact of solar PV systems in Normal, IL and uses the JEDI model to determine the county and state economic impact. The study examines the effect of 100 residential retrofit fixed-mount crystalline-silicone systems having a nameplate capacity of 5kW. Eight JEDI models estimated the economic impacts using different input assumptions. They found that county employment impacts varied from 377 to 1,059 job-years during construction and 18.8 to 40.5 job-years during the operating years. Each job-year is a full-time equivalent job of 2,080 hours for a year.

More recently, Michaud et. al (2020) performed an analysis of the economic impact of utility-scale solar energy projects in the State of Ohio. They detail three scenarios: low (2.5 GW), moderate (5 GW) and high (7.5 GW). Using the JEDI model, they find that between 18,039 and 54,113 jobs would be supported during construction and between 207 and 618 jobs would be supported annually during operations. In addition, between \$22.5 million and \$67.5 million annually in tax revenues would come from these projects.

Loomis et. al. (2016) estimates the economic impact for the State of Illinois if the state were to reach its maximum potential for solar PV. The study estimates the economic impact of three different scenarios for Illinois – building new solar installations of either 2,292 MW, 2,714 MW or 11,265 MW. The study assumes that 60% of the capacity is utility-scale solar, 30% of the capacity is commercial, and 10% of the capacity is residential. It was found that employment impacts vary from 26,753 to 131,779 job years during construction and from 1,223 to 6,010 job years during operating years.

Finally, Jenniches (2018) performed a review of the literature assessing the regional economic impacts of renewable energy sources. After reviewing all of the different techniques for analyzing the economic impacts, he concludes “for assessment of current renewable energy developments, beyond employment in larger regions, IO [Input-Output] tables are the most suitable approach.” (Jenniches, 2018, 48). Input-Output analysis is the basis for the methodology used in the economic impact analysis of this report. The JEDI PV model is an input-output model that measures the spending patterns and location-specific economic structures that reflect expenditures supporting varying levels of employment, income, and output. The JEDI PV model is the methodology used in this analysis and is explained in Section IV.



III. Project Description and Location

a. Stonefield Solar Project

Candela Renewables is developing the Stonefield Solar Project in Hardin County, Kentucky. The Project consists of an estimated 120-megawatt alternative current (MWac) utility-scale solar powered-electric generation facility that will utilize photovoltaic (PV) panels installed on a single-axis tracking system. The Project represents an investment in excess of \$114 million.

b. Hardin County, Kentucky

Hardin County is located in the Central part of Kentucky (see Figure 7). It has a total area of 630 square miles and the U.S. Census estimates that the 2019 population was 110,958 with 47,248 housing units. The county has a population density of 169 (persons per square mile) compared to 107 for the Commonwealth of Kentucky. Median household income in the county was \$54,367 (US. Census Bureau).

Figure 7 – Location of Hardin County, Kentucky

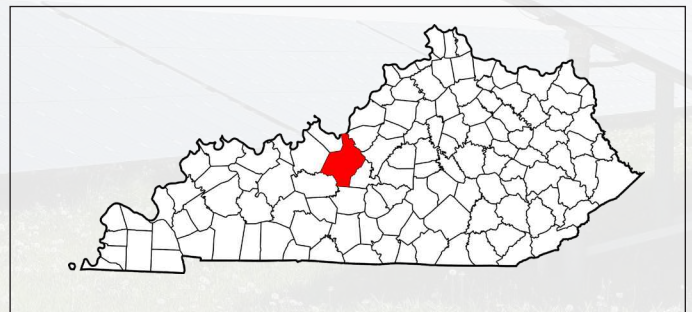

i. Economic and Demographic Statistics

As shown in Table 1, the largest industry is “Administrative Government” followed by “Manufacturing,” “Retail Trade” and “Accommodation and Food Services.” These data for Table 1 come from IMPLAN covering the year 2019 (the latest year available).

Table 1 – Employment by Industry in Hardin County

Industry	Number	Percent
Administrative Government	17,453	26.9%
Manufacturing	7,022	10.8%
Retail Trade	6,457	10.0%
Accommodation and Food Services	5,375	8.3%
Health Care and Social Assistance	4,617	7.1%
Administrative and Support and Waste Management and Remediation Services	3,603	5.6%
Professional, Scientific, and Technical Services	3,027	4.7%
Other Services (except Public Administration)	2,513	3.9%
Real Estate and Rental and Leasing	2,414	3.7%
Construction	2,394	3.7%
Finance and Insurance	2,069	3.2%
Agriculture, Forestry, Fishing and Hunting	1,666	2.6%
Transportation and Warehousing	1,631	2.5%
Information	925	1.4%
Wholesale Trade	877	1.4%
Management of Companies and Enterprises	723	1.1%
Government Enterprises	626	1.0%
Arts, Entertainment, and Recreation	625	1.0%
Mining, Quarrying, and Oil and Gas Extraction	363	0.6%
Educational Services	308	0.5%
Utilities	144	0.2%

Source: Impact Analysis for Planning (IMPLAN), County Employment by Industry, 2019

Table 1 provides the most recent snapshot of total employment but does not examine the historical trends within the county. Figure 8 shows employment from 2007 to 2019. Total employment in Hardin County was at its lowest at 62,761 in 2009 and its highest at 68,124 in 2011 (BEA, 2021). Since 2011, employment in the county has fluctuated.

Figure 8 – Total Employment in Hardin County from 2007 to 2019

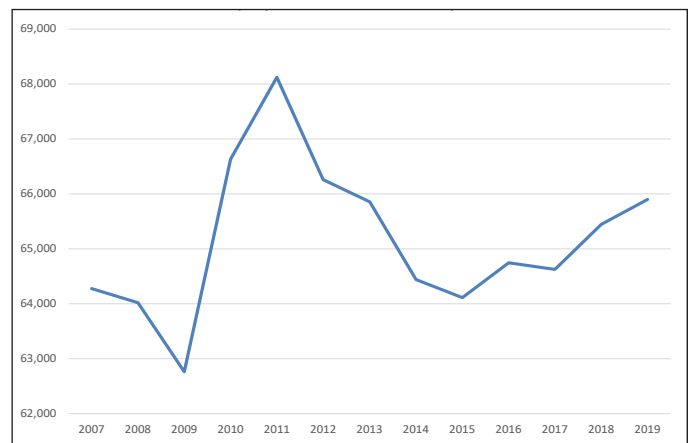

Source: Bureau of Economic Analysis, Regional Data, GDP and Personal Income, 2007-2019

Unlike the trend of employment, the overall population in the county has been increasing steadily, as shown in Figure 9. Hardin County population was 100,876 in 2010 and 108,527 in 2019, a gain of 7,651 (FRED, 2021). The average annual population increase over this time period was 850.

Similar to the population trend, household income has been trending upward in Hardin County. Figure 10 shows the median household income in Hardin County from 2010 to 2019. Household income was at its lowest at \$44,203 in 2010 and its highest at \$57,711 in 2019 (FRED, 2021).

Real Gross Domestic Product (GDP) is a measure of the value of goods and services produced in an area and adjusted for inflation over time. The Real GDP for Hardin County has been slowly increasing since hitting a low in 2015, as shown in Figure 11 (BEA, 2021).

Figure 10 – Median Household Income in Hardin County from 2010 to 2019

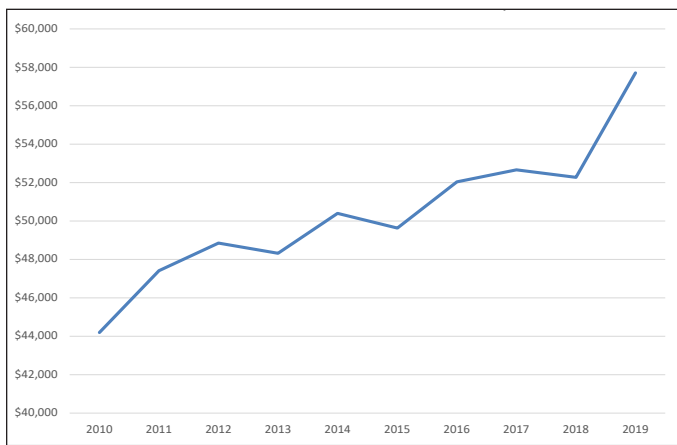

Source: Federal Reserve Bank of St. Louis Economic Data, U.S. Census Bureau, Estimate of Median Household Income, 2010-2019

Figure 9 – Population in Hardin County from 2010 to 2019

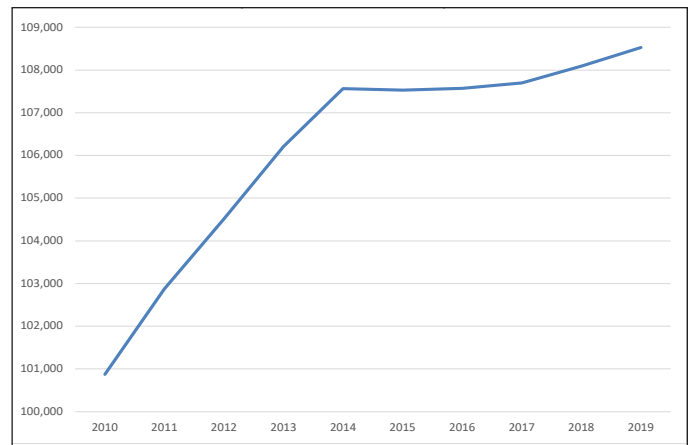

Source: Federal Reserve Bank of St. Louis Economic Data, U.S. Census Bureau, Population Estimates, 2010-2019

Figure 11 – Real Gross Domestic Product (GDP) in Hardin County from 2010 to 2019

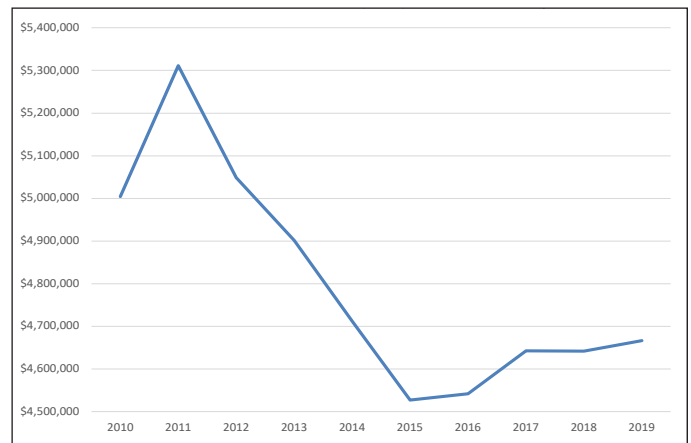

Source: Bureau of Economic Analysis, Regional Data, GDP and Personal Income, 2010-2019

The farming industry has declined in Hardin County. As shown in Figure 12, the number of farms has decreased from 1,810 in 1992 to 1,305 in 2017. The amount of land in farms has also decreased. The county farmland hit a high of 239,740 acres in 2002, and then falling to 199,201 acres in 2017 according to Figure 13.

Figure 12 – Number of Farms in Hardin County from 1992 to 2017

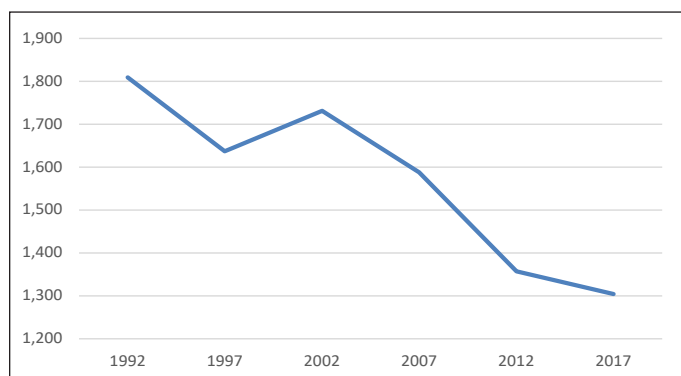

Source: Census of Agriculture, 1992-2017

Figure 13 – Land in Farms in Hardin County from 1992 to 2017

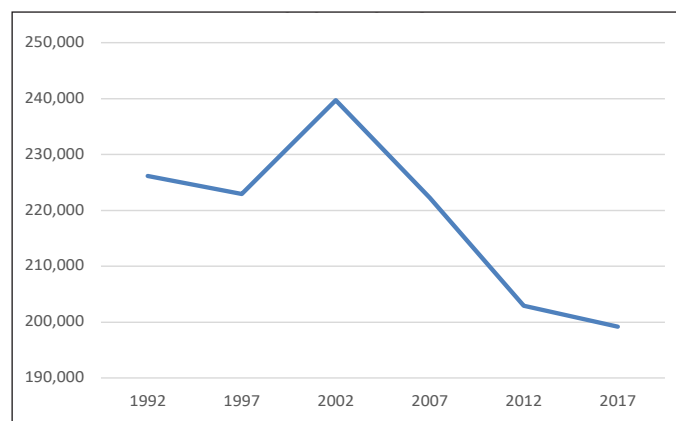

Source: Census of Agriculture, 1992-2017

ii. Agricultural Statistics

Kentucky is ranked twenty-sixth among U. S. states in total value of agricultural products sold (Census, 2017). It is ranked twenty-third in the value of livestock, and twenty-third in the value of crops (Census, 2017). In 2020, Kentucky had 74,500 farms and 12.9 million acres in operation with the average farm being 173 acres (United States Department of Agriculture, 2021). Kentucky had 48 thousand cattle and produced 938 million pounds of milk (United States Department of Agriculture, 2021). In 2020, Kentucky yields averaged 2.47 tons per acre for hay with a total market value of \$1.57 billion (United States Department of Agriculture, 2021). Soybean yields averaged 55 bushels per acre with a total market value of \$1.1 billion (United States Department of Agriculture, 2021). The average net cash farm income per farm is \$20,784 (Census, 2017).

In 2017, Hardin County had 1,305 farms covering 199,201 acres for an average farm size of 153 acres (Census, 2017). The total market value of products sold was \$59 million, with 30 percent coming from livestock sales and 70 percent coming from crop sales (Census, 2017). The average net cash farm income of operations was \$8,303 (Census, 2017).

IV. Economic Impact Methodology

The economic analysis of solar PV project presented uses National Renewable Energy Laboratories' Jobs and Economic Development Impacts (JEDI) PV Model (PV12.23.16). The JEDI PV Model is an input-output model that measures the spending patterns and location-specific economic structures that reflect expenditures supporting varying levels of employment, income, and output. That is, the JEDI PV Model takes into account that the output of one industry can be used as an input for another. For example, when a PV system is installed, there are both soft costs consisting of permitting, installation and customer acquisition costs, and hardware costs, of which the PV module is the largest component. The purchase of a module not only increases demand for manufactured components and raw materials, but also supports labor to build and install a module. When a module is purchased from a manufacturing facility, the manufacturer uses some of that money to pay employees. The employees use a portion of their compensation to purchase goods and services within their community. Likewise, when a developer pays workers to install the systems, those workers spend money in the local economy that boosts economic activity and employment in other sectors. The goal of economic impact analysis is to quantify all of those reverberations throughout the local and state economy.

The first JEDI Model was developed in 2002 to demonstrate the economic benefits associated with developing wind farms in the United States. Since then, JEDI models have been developed for biofuels, natural gas, coal, transmission lines and many other forms of energy. These models were created by Marshall Goldberg of MRG & Associates, under contract with the National Renewable Energy Laboratory. The JEDI model utilizes state-specific industry multipliers obtained from IMPLAN (Impact analysis for PLANning). IMPLAN software and data are managed and updated by the Minnesota IMPLAN Group, Inc., using data collected at federal, state, and local levels. This study analyzes the gross jobs that the new solar energy project development supports and does not analyze the potential loss of jobs due to declines in other forms of electric generation.

The total economic impact can be broken down into three distinct types: direct impacts, indirect impacts, and induced impacts. **Direct impacts** during the construction period refer to the changes that occur in the onsite construction industries in which the direct final demand (i.e., spending on construction labor and services) change is made. Onsite construction-related services include installation labor, engineering, design, and other professional services. Direct impacts during operating years refer to the final demand changes that occur in the onsite spending for the solar operations and maintenance workers.

The initial spending on the construction and operation of the solar PV installation will create a second layer of impacts, referred to as “supply chain impacts” or “indirect impacts.” **Indirect impacts** during the construction period consist of changes in inter-industry purchases resulting from the direct final demand changes and include construction spending on materials and PV equipment, as well as other purchases of goods and offsite services. Utility-scale solar PV indirect impacts include PV modules, inverters, tracking systems, cabling, and foundations.

Induced impacts during construction refer to the changes that occur in household spending as household income increases or decreases as a result of the direct and indirect effects of final demand changes. Local spending by employees working directly or indirectly on the Project that receive their paychecks and then spend money in the community is included. The JEDI model includes additional local jobs and economic activity that are supported by the purchases of these goods and services.



V. Economic Impact Results

The economic impact results were derived from detailed project cost estimates supplied by Candela Renewables. In addition, Candela Renewables also estimated the percentages of project materials and labor that will be coming from within Hardin County and the Commonwealth of Kentucky.

Two separate JEDI models were produced to show the economic impact of Stonefield Solar Project. The first JEDI model used the 2019 Hardin County multipliers from IMPLAN. The second JEDI model used the 2019 IMPLAN multipliers for the Commonwealth of Kentucky and the same project costs. Because all new multipliers from IMPLAN and specific project cost data from Stonefield Solar Project are used, the JEDI model serves only to translate the project costs into IMPLAN sectors.

Tables 2-4 show the output from these models. Table 2 lists the total employment impact from Stonefield Solar Project for Hardin County and the Commonwealth of Kentucky. Table 3 shows the impact on total earnings and Table 4 contains the impact on total output.

Table 2 – Total Employment Impact from Stonefield Solar Project

	Hardin County Jobs	Commonwealth of Kentucky
Construction		
Project Development and Onsite Labor Impacts (direct)	78	146
Module and Supply Chain Impacts (indirect)	10	38
Induced Impacts	4	26
<i>New Local Jobs during Construction</i>	93	209
Operations (Annual)		
Onsite Labor Impacts (direct)	1.8	2.0
Local Revenue and Supply Chain Impacts (indirect)	5.1	5.6
Induced Impacts	0.8	2.3
<i>New Local Long-Term Jobs</i>	7.6	9.9

The results from the JEDI model show significant employment impacts from Stonefield Solar Project. Employment impacts can be broken down into several different components. Direct jobs created during the construction phase typically last anywhere from 12 to 18 months depending on the size of the project; however, the direct job numbers present in Table 2 from the JEDI model are based on a full time equivalent (FTE) basis for a year. In other words, 1 job = 1 FTE = 2,080 hours worked in a year. A part time or temporary job would constitute only a fraction of a job according to the JEDI model. For example, the JEDI model results show 78 new direct jobs during construction in Hardin County, though the construction of the solar center could involve closer to 156 workers working half-time for a year. Thus, due to the short-term nature of construction projects, the JEDI model often significantly understates the number of people actually hired to work on the project. It is important to keep this fact in mind when looking at the numbers or when reporting the numbers.

As shown in Table 2, new local jobs created or retained during construction total over 93 for Hardin County, and over 209 for the Commonwealth of Kentucky. New local long-term jobs created from Stonefield Solar Project operations and maintenance activities total over 7.6 for Hardin County and over 9.9 for the Commonwealth of Kentucky.

Direct jobs created during the operational phase last the life of the solar PV project, typically 20-30 years. Direct construction jobs and operations and maintenance jobs both require highly-skilled workers in the fields of construction, management, and engineering. These well-paid professionals boost economic development in rural communities where new employment opportunities are often welcome due to economic downturns. Accordingly, it is important to not just look at the number of jobs but also the earnings that they produce. Table 3 shows the earnings impacts from Stonefield Solar Project, which are categorized by construction impacts and operations impacts. The new local earnings during construction totals over \$6.5 million for Hardin County and over \$14 million for the Commonwealth of Kentucky. The new local long-term earnings totals over \$290,000 for Hardin County and over \$503,000 for the Commonwealth of Kentucky.

Table 3 – Total Earnings Impact from Stonefield Solar Project

	Hardin County	Commonwealth of Kentucky
Construction		
Project Development and Onsite Earnings Impacts	\$5,916,008	\$10,949,738
Module and Supply Chain Impacts	\$423,890	\$1,890,347
Induced Impacts	\$193,873	\$1,213,185
<i>New Local Earnings during Construction</i>	\$6,533,771	\$14,053,270
Operations (Annual)		
Onsite Labor Impacts	\$58,785	\$130,332
Local Revenue and Supply Chain Impacts	\$199,083	\$263,089
Induced Impacts	\$32,949	\$109,953
<i>New Local Long-Term Earnings</i>	\$290,816	\$503,374

Output refers to economic activity or the value of production in the state or local economy. It is an equivalent measure to the Gross Domestic Product, which measures output on a national basis. According to Table 4, the new local output during construction totals over \$8 million for Hardin County and over \$21 million for the Commonwealth of Kentucky. The new local long-term output totals over \$1 million for Hardin County and over \$1.5 million for the Commonwealth of Kentucky.

Table 4 – Total Output Impact from Stonefield Solar Project

	Hardin County	Commonwealth of Kentucky
Construction		
Project Development and Onsite Jobs Impacts on Output	\$5,969,718	\$11,569,825
Module and Supply Chain Impacts	\$1,387,742	\$5,688,852
Induced Impacts	\$697,817	\$3,763,836
<i>New Local Output during Construction</i>	\$8,055,277	\$21,022,513
Operations (Annual)		
Onsite Labor Impacts	\$58,785	\$130,332
Local Revenue and Supply Chain Impacts	\$875,098	\$1,044,476
Induced Impacts	\$116,006	\$338,343
<i>New Local Long-Term Output</i>	\$1,049,889	\$1,513,151

VI. Tax Revenue

Utility size solar PV energy projects increase the property tax base of a county, creating a new revenue source for education and other local government services, such as fire protection, parks, health and safety. Stonefield Solar would be subject to manufacturing machinery, tangible personal property and real property taxes. Estimates of the taxable value of each type of property were derived in consultation with the client.

Table 5 details the tax implications of Stonefield Solar Project. There are several important assumptions built into the analysis in this table.

- First, the analysis assumes that the total taxable manufacturing machinery property at the start of the Project will be \$99.0 million, tangible personal property at the start of the Project will be \$9.8 million and that the total taxable real property will be \$6.2 million.
- Second, the table assumes annual depreciation of the manufacturing machinery property of 4% with a cap of 80% depreciation and annual depreciation of tangible personal property of 6.67% with a cap of 70% depreciation.
- Third, all tax rates are assumed to stay constant at their 2020 (2019 tax year) millage rates. For example, the Commonwealth of Kentucky rate for manufacturing machinery is 15, tangible personal property is 45 and real property is 11.9 (rates are cents per \$100 of assessed value). The Hardin County School District rate is 65.2 cents per \$100 of assessed value.
- Fourth, manufacturing machinery tax is only paid to the Commonwealth of Kentucky. Tangible personal property tax and real property tax is paid to both the state and the taxing entities within the county though some taxing entities have different rates for the different types of property.
- Fifth, no comprehensive tax payment was calculated, and these calculations are only to be used to illustrate the economic impact of the Project.
- Sixth, if Stonefield Solar pursues an Industrial Revenue Bond Resolution and Payment in Lieu of Taxes agreement, it would alter the state and county revenue projections.

As shown in Table 5, a conservative estimate of the total property taxes paid by the Project starts out at over \$331,000 per year and declines due to depreciation (and offset by the trending factor) until it reaches the maximum depreciation in 2042. The expected total property taxes paid over the 40-year lifetime of the Project is over \$6.7 million, and the average annual property taxes paid will be over \$167,000. The total amounts paid over 40 years are over \$874 for Timberland Fire Protection, over \$3,700 for Soil Conservation, over \$79,000 for Extension Services, over \$83,000 for the Health District, over \$460,000 for General Fiscal Court, and over \$3.6 million for the Commonwealth of Kentucky.

In Kentucky the largest taxing jurisdictions for property taxes are local school districts. However, the tax implications for school districts are more complicated than for other taxing bodies. School districts receive state aid based on the assessed value of the taxable property within its district. As assessed value increases, the state aid to the school district is decreased.

Table 5 also shows the direct property tax revenue coming from the Project to Hardin County School Districts. This tax revenue uses the assumptions outlined earlier to calculate the other tax revenue and assumes that 100% of the project area is in the school districts. Over the 40-year life of the Project, the school districts are expected to receive over \$2.4 million in tax revenue.

Table 5 – Total Property Taxes Paid by Stonefield Solar Project

Tax Year	Timberland Fire Protection	Soil Conservation	Extension Services	Health District	General Fiscal Court	Hardin County School Districts	State of Kentucky	Total Property Taxes
2024	\$22	\$93	\$3,726	\$3,516	\$19,762	\$104,190	\$199,774	\$331,083
2025	\$22	\$93	\$3,552	\$3,372	\$18,942	\$99,944	\$190,906	\$316,832
2026	\$22	\$93	\$3,378	\$3,229	\$18,121	\$95,698	\$182,039	\$302,581
2027	\$22	\$93	\$3,205	\$3,086	\$17,301	\$91,453	\$173,171	\$288,330
2028	\$22	\$93	\$3,031	\$2,943	\$16,480	\$87,207	\$164,304	\$274,079
2029	\$22	\$93	\$2,857	\$2,799	\$15,660	\$82,961	\$155,437	\$259,828
2030	\$22	\$93	\$2,683	\$2,656	\$14,839	\$78,715	\$146,569	\$245,577
2031	\$22	\$93	\$2,509	\$2,513	\$14,019	\$74,469	\$137,702	\$231,327
2032	\$22	\$93	\$2,335	\$2,370	\$13,198	\$70,223	\$128,834	\$217,076
2033	\$22	\$93	\$2,161	\$2,226	\$12,378	\$65,978	\$119,967	\$202,825
2034	\$22	\$93	\$1,988	\$2,083	\$11,557	\$61,732	\$111,100	\$188,574
2035	\$22	\$93	\$1,814	\$1,940	\$10,737	\$57,486	\$102,232	\$174,323
2036	\$22	\$93	\$1,640	\$1,796	\$9,916	\$53,240	\$93,365	\$160,072
2037	\$22	\$93	\$1,640	\$1,796	\$9,916	\$53,240	\$87,428	\$154,135
2038	\$22	\$93	\$1,640	\$1,796	\$9,916	\$53,240	\$81,491	\$148,198
2039	\$22	\$93	\$1,640	\$1,796	\$9,916	\$53,240	\$75,554	\$142,261
2040	\$22	\$93	\$1,640	\$1,796	\$9,916	\$53,240	\$69,617	\$136,324
2041	\$22	\$93	\$1,640	\$1,796	\$9,916	\$53,240	\$63,680	\$130,387
2042	\$22	\$93	\$1,640	\$1,796	\$9,916	\$53,240	\$60,711	\$127,419
2043	\$22	\$93	\$1,640	\$1,796	\$9,916	\$53,240	\$60,711	\$127,419
2044	\$22	\$93	\$1,640	\$1,796	\$9,916	\$53,240	\$60,711	\$127,419
2045	\$22	\$93	\$1,640	\$1,796	\$9,916	\$53,240	\$60,711	\$127,419
2046	\$22	\$93	\$1,640	\$1,796	\$9,916	\$53,240	\$60,711	\$127,419
2047	\$22	\$93	\$1,640	\$1,796	\$9,916	\$53,240	\$60,711	\$127,419
2048	\$22	\$93	\$1,640	\$1,796	\$9,916	\$53,240	\$60,711	\$127,419
2049	\$22	\$93	\$1,640	\$1,796	\$9,916	\$53,240	\$60,711	\$127,419
2050	\$22	\$93	\$1,640	\$1,796	\$9,916	\$53,240	\$60,711	\$127,419
2051	\$22	\$93	\$1,640	\$1,796	\$9,916	\$53,240	\$60,711	\$127,419
2052	\$22	\$93	\$1,640	\$1,796	\$9,916	\$53,240	\$60,711	\$127,419
2053	\$22	\$93	\$1,640	\$1,796	\$9,916	\$53,240	\$60,711	\$127,419
2054	\$22	\$93	\$1,640	\$1,796	\$9,916	\$53,240	\$60,711	\$127,419
2055	\$22	\$93	\$1,640	\$1,796	\$9,916	\$53,240	\$60,711	\$127,419
2056	\$22	\$93	\$1,640	\$1,796	\$9,916	\$53,240	\$60,711	\$127,419
2057	\$22	\$93	\$1,640	\$1,796	\$9,916	\$53,240	\$60,711	\$127,419
2058	\$22	\$93	\$1,640	\$1,796	\$9,916	\$53,240	\$60,711	\$127,419
2059	\$22	\$93	\$1,640	\$1,796	\$9,916	\$53,240	\$60,711	\$127,419
2060	\$22	\$93	\$1,640	\$1,796	\$9,916	\$53,240	\$60,711	\$127,419
2061	\$22	\$93	\$1,640	\$1,796	\$9,916	\$53,240	\$60,711	\$127,419
2062	\$22	\$93	\$1,640	\$1,796	\$9,916	\$53,240	\$60,711	\$127,419
2063	\$22	\$93	\$1,640	\$1,796	\$9,916	\$53,240	\$60,711	\$127,419
TOTAL	\$874	\$3,727	\$79,153	\$83,033	\$460,641	\$2,460,782	\$3,618,813	\$6,707,023
AVG ANNUAL	\$22	\$93	\$1,979	\$2,076	\$11,516	\$61,520	\$90,470	\$167,676

Source: Author's calculations

VII. Conclusion

In summary, Stonefield Solar Project, a 120-megawatt alternating current (MWac) utility-scale solar project represents an investment in excess of \$114 million. The total development is anticipated to result in the following:

Jobs – all jobs numbers are full-time equivalents

- Over 93 new local jobs during construction for Hardin County
- Over 209 new local jobs during construction for the Commonwealth of Kentucky
- Over 7.6 new local long-term jobs for Hardin County
- Over 9.9 new local long-term jobs for the Commonwealth of Kentucky

Earnings

- Over \$6.5 million in new local earnings during construction for Hardin County
- Over \$14 million in new local earnings during construction for the Commonwealth of Kentucky
- Over \$290 thousand in new local long-term earnings for Hardin County annually
- Over \$503 thousand in new local long-term earnings for the Commonwealth of Kentucky annually

Output

- Over \$8 million in new local output during construction for Hardin County
- Over \$21 million in new local output during construction for the Commonwealth of Kentucky
- Over \$1 million in new local long-term output for Hardin County annually
- Over \$1.5 million in new local long-term output for the Commonwealth of Kentucky

Property Taxes

- Over \$2.4 million in total school district revenue over the life of the Project
- Over \$626 thousand in total county property taxes for Hardin County over the life of the Project
- Over \$6.7 million in property taxes in total for all taxing districts over the life of the Project

VIII. References

Bureau of Economic Analysis (BEA). (2021). Interactive Data Tools: Regional Data. GDP and Personal Income. Accessed at <https://apps.bea.gov/iTable/iTable.cfm?reqid=70&step=1&isuri=1>

Berkman, M., M. Tran, and W. Ahlgren. 2011. "Economic and Fiscal Impacts of the Desert Sunlight Solar Farm." Prepared for First Solar, Tempe, AZ (US).

Bezdek (2007) Economic and Jobs Impacts of the Renewable Energy and Energy Efficiency Industries: U.S. and Ohio, presented at SOLAR 2007, Cleveland, Ohio, accessed at https://www.utoledo.edu/centers/urban-affairs/publications/jobs_report.pdf.

Bhavin, Shah. (2008). Solar Cell Supply Chain. Asia Pacific Equity Research, accessed on 11/1/2013 at <https://www.slideshare.net/JackChalice/solar-cell-supply-chain>.

Census of Agriculture – Kentucky State and County Data. (1992). United States Department of Agriculture. Accessed at <http://lib-usda-05.serverfarm.cornell.edu/usda/AgCensusImages/1992/01/17/1570/Table-01.pdf>.

Census of Agriculture – Kentucky State and County Data. (1997). United States Department of Agriculture. Accessed at <http://lib-usda-05.serverfarm.cornell.edu/usda/AgCensusImages/1997/01/17/1600/Table-01.pdf>.

Census of Agriculture – Kentucky State and County Data. (2002). United States Department of Agriculture. Accessed at <http://lib-usda-05.serverfarm.cornell.edu/usda/AgCensusImages/2002/01/17/1704/Table-01.pdf>.

Census of Agriculture – Kentucky State and County Data. (2007). United States Department of Agriculture. Accessed at https://www.nass.usda.gov/Publications/AgCensus/2007/Full_Report/Volume_1,_Chapter_2_County_Level/Kentucky/st21_2_001_001.pdf.

Census of Agriculture – Kentucky State and County Data. (2012). United States Department of Agriculture. Accessed at https://www.nass.usda.gov/Publications/AgCensus/2012/Full_Report/Volume_1,_Chapter_2_County_Level/Kentucky/st21_2_001_001.pdf.

Census of Agriculture – Kentucky State and County Data. (2017). United States Department of Agriculture. Accessed at https://www.nass.usda.gov/Publications/AgCensus/2017/Full_Report/Volume_1,_Chapter_2_County_Level/Kentucky/st21_2_0001_0001.pdf.

Center for Competitive Florida. (2009). The Positive Economic Impact of Solar Energy on the Sunshine State, Briefings, accessed 11/25/2013 at <https://floridatxwatch.org/Research/Blog/ArtMID/34888/ArticleID/15997/The-Positive-Economic-Impact-of-Solar-Energy-on-the-Sunshine-State>.

Center for Rural Affairs. 2021. Taxing Utility-Scale Solar Projects in Iowa, accessed 5/21/21 at: <https://www.cfra.org/publications/resource-guide-taxing-utility-scale-solar-projects-iowa>

Croucher, Matt, 2012. Which state is Yoda?. *Energy Policy*, Elsevier, vol. 42(C), pages 613-615.

Federal Reserve Bank of St. Louis Economic Data (FRED). (2021). U.S. Census Bureau, Population Estimates. Accessed at <https://fred.stlouisfed.org/searchresults/?st=population>.

Federal Reserve Bank of St. Louis Economic Data (FRED). (2021). U.S. Census Bureau, Median Household Income. Accessed at <https://fred.stlouisfed.org/searchresults/?st=Median%20household%20income>

IMPLAN Group LLC. IMPLAN 2021. Huntersville, NC. IMPLAN.com.

Jenniches, Simon. 2018. Assessing the Regional Economic Impacts of Renewable Energy Sources, *Renewable and Sustainable Energy Reviews*, Elsevier, 93, 35-51. Accessed at <https://www.sciencedirect.com/science/article/pii/S1364032118303447>.

Jo, J.H., Cross, J., Rose, Z., Daebel, E., Verderber, A., and Loomis, D. G. (2016). Financing options and economic impact: distributed generation using solar photovoltaic systems in Normal, Illinois, *AIMS Energy*, 4(3): 504-516.

Jo J. H., Loomis, D.G., and Aldeman, M. R. (2013). Optimum penetration of utility-scale grid-connected solar photovoltaic systems in Illinois, *Renewable Energy*, 60, 20-26. Accessed at <https://www.semanticscholar.org/paper/Optimum-penetration-of-utility-scale-grid-connected-Jo-Loomis/e5c89236f450baf9a84f8b64efc29ab3aa81015e>.

Loomis, D.G., Jo, J.H., and Aldeman, M.R., (2016). Economic Impact Potential of Solar Photovoltaics in Illinois, *Renewable Energy*, 87, 253-258.

Michaud, G., Khalaf, C., Zimmer, M. & Jenkins, D. (2020). Measuring the economic impacts of utility-scale solar in Ohio. Developed for the Utility Scale Solar Energy Coalition of Ohio (USSEC). Accessed at <https://www.ohio.edu/voinovich-school/news-resources/reports-publications/utility-scale-solar>.

National Renewable Energy Laboratories. (2012). Utility-Scale Concentrating Solar Power and Photovoltaics Projects: A Technology and Market Overview. National Renewable Energy Laboratory. Accessed at <https://www.nrel.gov/docs/fy12osti/51137.pdf>.

Overview of the Solar Energy Industry and Supply Chain, accessed on 10/30/2013 at <http://www.thecemc.org>.

Platt, R.H. (1985). The Farmland Conversion Debate: NALS and Beyond. *The Professional Geographer*, 37 (4), 433-442. Accessed at <https://www.tandfonline.com/doi/abs/10.1111/j.0033-0124.1985.00433.x>.

Solar Energy Industries Association (SEIA). (2021). State Solar Spotlight: Kentucky. September 2021. Solar Energy Industries Association, accessed at <https://www.seia.org/sites/default/files/2021-09/Kentucky.pdf>

Solar Energy Industries Association (SEIA). (2021). U.S. Solar Market Insight Report 2021 Q2. June 2021. Solar Energy Industries Association, accessed at <https://www.seia.org/research-resources/solar-market-insight-report-2021-q2>.

Solar Energy Industries Association (SEIA). (2021). U.S. Solar Market Insight Report 2021 Q3. September 2021. Solar Energy Industries Association, accessed at <https://www.seia.org/research-resources/solar-market-insight-report-2021-q3>.

Solar Foundation. (2013). An Assessment of the Economic, Revenue, and Societal Impacts of Colorado's Solar Industry. October 2013, accessed at https://www.bizjournals.com/denver/blog/earth_to_power/2013/10/solar-power-industry-says-economic.html.

Stone & Associates (2011). Overview of the Solar Energy Industry and Supply Chain, Prepared for the Blue Green Alliance, accessed at <https://www.bgafoundation.org/wp-content/uploads/2016/08/>

Solar-Overview-for-BGA-Final-Jan-2011.pdf. Toothman, Jessica, and Aldous, Scott. (2013). How Solar Cells Work, How Stuff Works, accessed at <https://science.howstuffworks.com/environmental/energy/solar-cell.htm>.

United States Census Bureau. (2021). QuickFacts: Hardin County, Kentucky. Accessed at <https://www.census.gov/quickfacts/hardincountykentucky>.

United States Department of Agriculture (USDA). (2021). 2020 State Agricultural Overview: Kentucky. Accessed at https://www.nass.usda.gov/Quick_Stats/Ag_Overview/stateOverview.php?state=KENTUCKY

U.S. Department of Energy. (2020). 2020 U.S. Energy & Employment Report. Energy Employment by State. Accessed at <https://static1.squarespace.com/static/5a98cf80ec4eb7c5cd928c61/t/5e78198f28dc473dd3225f04/1584929183186/USEER-Energy-Employment-by-State-2020.pdf>.

IX. Curriculum Vita - David G. Loomis

David G. Loomis
 Illinois State University
 Department of Economics
 Campus Box 4200
 Normal, IL 61790-4200
 (815) 905-2750
 dloomis@ilstu.edu

Education

Doctor of Philosophy, Economics, Temple University, Philadelphia, Pennsylvania, May 1995.

Bachelor of Arts, Mathematics and Honors Economics, Temple University, Magna Cum Laude, May 1985.

Experience

1996-present Illinois State University, Normal, IL
 Full Professor – Department of Economics (2010-present)

Associate Professor - Department of Economics (2002-2009)

Assistant Professor - Department of Economics (1996-2002)

- Taught Regulatory Economics, Telecommunications Economics and Public Policy, Industrial Organization and Pricing, Individual and Social Choice, Economics of Energy and Public Policy and a Graduate Seminar Course in Electricity, Natural Gas and Telecommunications Issues.
- Supervised as many as 5 graduate students in research projects each semester.
- Served on numerous departmental committees.

1997-present Institute for Regulatory Policy Studies, Normal, IL

Executive Director (2005-present)

Co-Director (1997-2005)

- Grew contributing membership from 5 companies to 16 organizations.
- Doubled the number of workshop/training events annually.
- Supervised 2 Directors, Administrative Staff and internship program.
- Developed and implemented state-level workshops concerning regulatory issues related to the electric, natural gas, and telecommunications industries.

2006-2018 Illinois Wind Working Group, Normal, IL

Director

- Founded the organization and grew the organizing committee to over 200 key wind stakeholders
- Organized annual wind energy conference with over 400 attendees
- Organized strategic conferences to address critical wind energy issues
- Initiated monthly conference calls to stakeholders
- Devised organizational structure and bylaws

2007-2018 Center for Renewable Energy, Normal, IL
Director

- Created founding document approved by the Illinois State University Board of Trustees and Illinois Board of Higher Education.
- Secured over \$150,000 in funding from private companies.
- Hired and supervised 4 professional staff members and supervised 3 faculty members as Associate Directors.
- Reviewed renewable energy manufacturing grant applications for Illinois Department of Commerce and Economic Opportunity for a \$30 million program.
- Created technical “Due Diligence” documents for the Illinois Finance Authority loan program for wind farm projects in Illinois.

2011-present Strategic Economic Research, LLC
President

- Performed economic impact analyses on policy initiatives and energy projects such as wind energy, solar energy, natural gas plants and transmission lines at the county and state level.
- Provided expert testimony before state legislative bodies, state public utility commissions, and county boards.
- Wrote telecommunications policy impact report comparing Illinois to other Midwestern states.

1997-2002 International Communications
Forecasting Conference

Chair

- Expanded Planning Committee with representatives from over 18 different international companies and delivered high quality conference attracting over 500 people over 4 years.

1985-1996 Bell Atlantic, Philadelphia, Pa.
Economist - Business Research

- Wrote and taught Applied Business Forecasting multimedia course.
- Developed and documented 25 econometric demand models that were used in regulatory filings.
- Provided statistical and analytic support to regulatory costing studies.
- Served as subject matter expert in switched and special access.
- Administered \$4 million budget including \$1.8 million consulting budget.

Professional Awards and Memberships

2016 Outstanding Cross-Disciplinary Team Research Award with Jin Jo and Matt Aldeman – recognizes exemplary collaborative research conducted by multiple investigators from different disciplines.

2011 Midwestern Regional Wind Advocacy Award from the U. S. Department of Energy's Wind Powering America presented at WindPower 2011

2009 Economics Department Scott M. Elliott Faculty Excellence Award – awarded to faculty who demonstrate excellence in teaching, research and service.

2009 Illinois State University Million Dollar Club – awarded to faculty who have over \$1 million in grants through the university.

2008 Outstanding State Wind Working Group Award from the U. S. Department of Energy's Wind Power America presented at WindPower 2008.

1999 Illinois State University Teaching Initiative Award

Member of the American Economic Association, National Association of Business Economists, International Association for Energy Economics, Institute for Business Forecasters; Institute for International Forecasters, International Telecommunications Society.

Professional Publications

34. Aldeman, M.R., Jo, J.H., and Loomis, D.G. (2018). Quantification of Uncertainty Associated with Wind Assessments of Various Intervals, Transactions of the Canadian Society for Mechanical Engineering, forthcoming.

33. Jin, J.H., Cross, J., Rose, Z., Daebel, E., Verderber, A., and Loomis, D. G. (2016). Financing options and economic impact: distributed generation using solar photovoltaic systems in Normal, Illinois, AIMS Energy, 4(3): 504-516.

32. Loomis, D.G., Hayden, J., Noll, S. and Payne, J.E. (2016). Economic Impact of Wind Energy Development in Illinois, The Journal of Business Valuation and Economic Loss Analysis, 11(1), 3-23.

31. Loomis, D.G., Jo, J.H., and Aldeman, M.R., (2016). Economic Impact Potential of Solar Photovoltaics in Illinois, Renewable Energy, 87, 253-258.

30. Aldeman, M.R., Jo, J.H., and Loomis, D.G. (2015). The Technical Potential for Wind Energy in Illinois, Energy, 90(1), 1082-1090.

29. Tegen, S., Keyser, D., Flores-Espino, F., Miles, J., Zammit, D. and Loomis, D. (2015). Offshore Wind Jobs and Economic Development Impacts in the United States: Four Regional Scenarios, National Renewable Energy Laboratory Technical Report, NREL/TP-5000-61315, February.

28. Loomis, D. G. and Bowden, N. S. (2013). Nationwide Database of Electric Rates to Become Available, Natural Gas & Electricity, 30 (5), 20-25.

-
27. Jin, J. H., Loomis, D. G., and Aldeman, M. R. (2013). Optimum penetration of utility-scale grid-connected solar photovoltaic systems in Illinois, *Renewable Energy*, 60, 20-26.
26. Malm, E., Loomis, D. G., DeFranco, J. (2012). A Campus Technology Choice Model with Incorporated Network Effects: Choosing Between General Use and Campus Systems, *International Journal of Computer Trends and Technology*, 3(4), 622-629.
25. Chupp, B. A., Hickey, E.A. & Loomis, D. G. (2012). Optimal Wind Portfolios in Illinois, *Electricity Journal*, 25, 46-56.
24. Hickey, E., Loomis, D. G., & Mohammadi, H. (2012). Forecasting hourly electricity prices using ARMAX-GARCH models: An application to MISO hubs, *Energy Economics*, 34, 307-315.
23. Theron, S., Winter, J.R, Loomis, D. G., & Spaulding, A. D. (2011). Attitudes Concerning Wind Energy in Central Illinois. *Journal of the America Society of Farm Managers and Rural Appraisers*, 74, 120-128.
22. Payne, J. E., Loomis, D. G. & Wilson, R. (2011). Residential Natural Gas Demand in Illinois: Evidence from the ARDL Bounds Testing Approach. *Journal of Regional Analysis and Policy*, 41(2), 138.
21. Loomis, D. G. & Ohler, A. O. (2010). Are Renewable Portfolio Standards A Policy Cure-all? A Case Study of Illinois's Experience. *Environmental Law and Policy Review*, 35, 135-182.
20. Gil-Alana, L. A., Loomis, D. G., & Payne, J. E. (2010). Does energy consumption by the U.S. electric power sector exhibit long memory behavior? *Energy Policy*, 38, 7512-7518.
19. Carlson, J. L., Payne, J. E., & Loomis, D. G. (2010). An assessment of the Economic Impact of the Wind Turbine Supply Chain in Illinois. *Electricity Journal*, 13, 75-93.
18. Apergis, N., Payne, J. E., & Loomis, D. G. (2010). Are shocks to natural gas consumption transitory or permanent? *Energy Policy*, 38, 4734-4736.
17. Apergis, N., Payne, J. E., & Loomis, D. G. (2010). Are fluctuations in coal consumption transitory or permanent? Evidence from a panel of U.S. states. *Applied Energy*, 87, 2424-2426.
16. Hickey, E. A., Carlson, J. L., & Loomis, D. G. (2010). Issues in the determination of the optimal portfolio of electricity supply options. *Energy Policy*, 38, 2198-2207.
15. Carlson, J. L., & Loomis, D. G. (2008). An assessment of the impact of deregulation on the relative price of electricity in Illinois. *Electricity Journal*, 21, 60-70.
14. Loomis, D. G., (2008). The telecommunications industry. In H. Bidgoli (Ed.), *The handbook of computer networks* (pp. 3-19). Hoboken, NJ: John Wiley & Sons.
13. Cox, J. E., Jr., & Loomis, D. G. (2007). A managerial approach to using error measures in the evaluation of forecasting methods. *International Journal of Business Research*, 7, 143-149.

Professional Publications (continued)

12. Cox, J. E., Jr., & Loomis, D. G. (2006). Improving forecasting through textbooks – a 25 year review. *International Journal of Forecasting*, 22, 617-624.
11. Swann, C. M., & Loomis, D. G. (2005). Competition in local telecommunications – there's more than you think. *Business Economics*, 40, 18-28.
10. Swann, C. M., & Loomis, D. G. (2005). Intermodal competition in local telecommunications markets. *Information Economics and Policy*, 17, 97-113.
9. Swann, C. M., & Loomis, D. G. (2004). Telecommunications demand forecasting with intermodal competition – a multi-equation modeling approach. *Teletronikk*, 100, 180-184.
8. Cox, J. E., Jr., & Loomis, D. G. (2003). Principles for teaching economic forecasting. *International Review of Economics Education*, 1, 69-79.
7. Taylor, L. D. & Loomis, D. G. (2002). *Forecasting the internet: understanding the explosive growth of data communications*. Boston: Kluwer Academic Publishers.
6. Wiedman, J. & Loomis, D. G. (2002). U.S. broadband pricing and alternatives for internet service providers. In D. G. Loomis & L. D. Taylor (Eds.) Boston: Kluwer Academic Publishers.
5. Cox, J. E., Jr. & Loomis, D. G. (2001). Diffusion of forecasting principles: an assessment of books relevant to forecasting. In J. S. Armstrong (Ed.), *Principles of Forecasting: A Handbook for Researchers and Practitioners* (pp. 633-650). Norwell, MA: Kluwer Academic Publishers.
4. Cox, J. E., Jr. & Loomis, D. G. (2000). A course in economic forecasting: rationale and content. *Journal of Economics Education*, 31, 349-357.
3. Malm, E. & Loomis, D. G. (1999). Active market share: measuring competitiveness in retail energy markets. *Utilities Policy*, 8, 213-221.
2. Loomis, D. G. (1999). Forecasting of new products and the impact of competition. In D. G. Loomis & L. D. Taylor (Eds.), *The future of the telecommunications industry: forecasting and demand analysis*. Boston: Kluwer Academic Publishers.
1. Loomis, D. G. (1997). Strategic substitutes and strategic complements with interdependent demands. *The Review of Industrial Organization*, 12, 781-791.

Expert Testimony

23. McLean County (Illinois) Zoning Board of Appeals, Application for Special Use Permit for a Wind Energy Conversion System, on behalf of Invenergy, LLC, Direct Oral Testimony, January 4, 2018.
22. New Mexico Public Regulation Commission, Case No. 17-00275-UT, Application of Sagamore Wind Energy LLC, on behalf of Invenergy, LLC, Direct Written Testimony filed November 6, 2017.
21. Ohio Power Siting Board, Case No. 17-773-EL-BGN, In the Matter of Hardin Solar Energy LLC for a Certificate of Environmental Compatibility and Public Need to Construct a Solar-Powered Electric Generation Facility in Hardin County, Ohio, on behalf of Invenergy, LLC, Exhibit with Report filed July 5, 2017.
20. Macon County (Illinois) Environmental, Education, Health and Welfare Committee, Application for Special Use Permit for a Wind Energy Conversion System, on behalf of E.ON Energy, Direct Oral Testimony, August 20, 2015.
19. Illinois Commerce Commission, Case No. 15-0277, Oral Cross-examination Testimony on behalf of Grain Belt Express Clean Line LLC appeared before the Commission on August 19, 2015.
18. Macon County (Illinois) Zoning Board of Appeals, Application for Special Use Permit for a Wind Energy Conversion System, on behalf of E.ON Energy, Direct Oral Testimony, August 11, 2015.
17. Illinois Commerce Commission, Case No. 15-0277, Written Rebuttal Testimony on behalf of Grain Belt Express Clean Line LLC filed August 7, 2015.
16. Kankakee County (Illinois) Planning, Zoning, and Agriculture Committee, Application for Special Use Permit for a Wind Energy Conversion System, on behalf of EDF Renewables, Direct Oral Testimony, July 22, 2015.
15. Kankakee County (Illinois) Zoning Board of Appeals, Application for Special Use Permit for a Wind Energy Conversion System, on behalf of EDF Renewables, Direct Oral Testimony, July 13, 2015.
14. Bureau County (Illinois) Zoning Board of Appeals, Application for Special Use Permit for a Wind Energy Conversion System, on behalf of Berkshire Hathaway Energy/Geronimo Energy, Direct Oral Testimony, June 16, 2015.
13. Illinois Commerce Commission, Case No. 15-0277, Written Direct Testimony on behalf of Grain Belt Express Clean Line LLC filed April 10, 2015.
12. Livingston County (Illinois) Zoning Board of Appeals, Application for Special Use Permit for a Wind Energy Conversion System, on behalf of Invenergy, Oral Cross-Examination, December 8-9, 2014.
11. Missouri Public Service Commission, Case No. EA-2014-0207, Oral Cross-examination Testimony on behalf of Grain Belt Express Clean Line LLC appeared before the Commission on November 21, 2014.

Expert Testimony (continued)

10. Livingston County (Illinois) Zoning Board of Appeals, Application for Special Use Permit for a Wind Energy Conversion System, on behalf of Invenergy, Direct Oral Testimony, November 17-19, 2014.
9. Missouri Public Service Commission, Case No. EA-2014-0207, Written Surrebuttal Testimony on behalf of Grain Belt Express Clean Line LLC, filed October 14, 2014.
8. Missouri Public Service Commission, Case No. EA-2014-0207, Written Direct Testimony on behalf of Grain Belt Express Clean Line LLC, filed March 26, 2014.
7. Illinois Commerce Commission, Case No. 12-0560, Oral Cross-examination Testimony on behalf of Rock Island Clean Line LLC appeared before the Commission on December 11, 2013.
6. Illinois Commerce Commission, Case No. 12-0560, Written Rebuttal Testimony on behalf of Rock Island Clean Line LLC filed August 20, 2013.
5. Boone County (Illinois) Board, Examination of Wind Energy Conversion System Ordinance, Direct Testimony and Cross-Examination, April 23, 2013.
4. Illinois Commerce Commission, Case No. 12-0560, Written Direct Testimony on behalf of Rock Island Clean Line LLC filed October 10, 2012.
3. Whiteside County (Illinois) Board and Whiteside County Planning and Zoning Committee, Examination of Wind Energy Conversion System Ordinance, Direct Testimony and Cross-Examination, on behalf of the Center for Renewable Energy, April 12, 2012.
2. State of Illinois Senate Energy and Environment Committee, Direct Testimony and Cross-Examination, on behalf of the Center for Renewable Energy, October 28, 2010.
1. Livingston County (Illinois) Zoning Board of Appeals, Application for Special Use Permit for a Wind Energy Conversion System, on behalf of the Center for Renewable Energy, Direct Testimony and Cross-Examination, July 28, 2010.

Selected Presentations

“Smart Cities and Micro Grids: Cost Recovery Issues,” presented September 12, 2017 at the National Association of Regulatory Utility Commissioners Staff Subcommittee on Accounting and Finance Meeting, Springfield, IL.

“Cloud Computing: Regulatory Principles and ICC NOI,” presented September 11, 2017 at the National Association of Regulatory Utility Commissioners Staff Subcommittee on Accounting and Finance Meeting, Springfield, IL.

“Illinois Wind, Illinois Solar and the Illinois Future Energy Jobs Act,” presented July 25, 2017 at the Illinois County Assessors Meeting, Normal, IL.

“Illinois Wind, Illinois Solar and the Illinois Future Energy Jobs Act,” presented April 21, 2017 at the Illinois Association of County Zoning Officers Meeting, Bloomington, IL.

“Energy Storage Economics and RTOs,” presented October 30, 2016 at the Energy Storage Conference at Argonne National Laboratory.

“Wind Energy in Illinois,” on October 6, 2016 at the B/N Daybreak Rotary Club, Bloomington, IL.

“Smart Grid for Schools,” presented August 17, 2016 to the Ameren External Affairs Meeting, Decatur, IL.

“Solar Energy in Illinois,” presented July 28, 2016 at the 3rd Annual K-12 Teachers Clean Energy Workshop, Richland Community College, Decatur, IL.

“Wind Energy in Illinois,” presented July 28, 2016 at the 3rd Annual K-12 Teachers Clean Energy Workshop, Richland Community College, Decatur, IL.

“Smart Grid for Schools,” presented June 21, 2016 at the ISEIF Grantee and Ameren Meeting, Decatur, IL.

“Costs and Benefits of Renewable Energy,” presented November 4, 2015 at the Osher Lifelong Learning Institute at Bradley, University, Peoria, IL.

“Energy Sector Workforce Issues,” presented September 17, 2015 at the Illinois Workforce Investment Board, Springfield, IL.

“The Past, Present and Future of Wind Energy in Illinois,” presented March 13, 2015 at the Peoria Rotary Club, Peoria, IL.

“Where Are All the Green Jobs?” presented January 28, 2015 at the 2015 Illinois Green Economy Network Sustainability Conference, Normal, IL.

“Teaching Next Generation Energy Concepts with Next Generation Science Standards: Addressing the Critical Need for a More Energy-Literate Workforce,” presented September 30, 2014 at the Mathematics and Science Partnerships Program 2014 Conference in Washington, DC.

“National Utility Rate Database,” presented October 23, 2013 at Solar Power International, Chicago, IL.

Selected Presentations (continued)

“Potential Economic Impact of Offshore Wind Energy in the Great Lakes,” presented May 6, 2013 at WindPower 2013, Chicago, IL.

“Why Illinois? Windy City, Prairie Power,” presented May 5, 2013 at WindPower 2013, Chicago, IL.

“National Utility Rate Database,” presented January 29, 2013 at the EUEC Conference, Phoenix, AZ.

“Energy Learning Exchange and Green Jobs,” presented December 13, 2012 at the TRICON Meeting of Peoria and Tazewell County Counselors, Peoria, IL.

“Potential Economic Impact of Offshore Wind Energy in the Great Lakes,” presented November 12, 2012 at the Offshore Wind Jobs and Economic Development Impacts Webinar.

“Energy Learning Exchange,” presented October 31, 2012 at the Utility Workforce Development Meeting, Chicago, IL.

“Wind Energy in McLean County,” presented June 26, 2012 at BN By the Numbers, Normal, IL.

“Wind Energy,” presented June 14, 2012 at the Wind for Schools Statewide Teacher Workshop, Normal, IL.

“Economic Impact of Wind Energy in Illinois,” presented June 6, 2012 at AWEA’s WINDPOWER 2012, Atlanta, GA.

“Trends in Illinois Wind Energy,” presented March 6, 2012 at the AWEA Regional Wind Energy Summit – Midwest in Chicago, IL.

“Challenges and New Growth Strategies in the Wind Energy Business,” invited plenary session speaker at the Green Revolution Leaders Forum, November 18, 2011 in Seoul, South Korea.

“Overview of the Center for Renewable Energy,” presented July 20, 2011 at the University-Industry Consortium Meeting at Illinois Institute of Technology, Chicago, IL.

“Building the Wind Turbine Supply Chain,” presented May 11, 2011 at the Supply Chain Growth Conference, Chicago, IL

“Building a Regional Energy Policy for Economic Development,” presented April 4, 2011 at the Midwestern Legislative Conference’s Economic Development Committee Webinar.

“Wind Energy 101,” presented February 7, 2011 at the Wind Power in Central Illinois - A Public Forum, CCNET Renewable Energy Group, Champaign, IL. “Alternative Energy Strategies,” presented with Matt Aldeman November 19, 2010 at the Innovation Talent STEM Education Forum, Chicago, IL.

“Siting and Zoning in Illinois,” presented November 17, 2010 at the Wind Powering America Webinar.

“What Governor Quinn Should Do about Energy?” presented November 15, 2010 at the Illinois Chamber of Commerce Energy Forum Conference, Chicago, IL.

“Is Wind Energy Development Right for Illinois,” presented with Matt Aldeman October 28, 2010 at the Illinois Association of Illinois County Zoning Officials Annual Seminar in Utica, IL.

“Economic Impact of Wind Energy in Illinois,” presented July 22, 2010 at the AgriEnergy Conference in Champaign, IL.

“Renewable Energy Major at ISU,” presented July 21, 2010 at Green Universities and Colleges Subcommittee Webinar.

“Economics of Wind Energy,” presented May 19, 2010 at the U.S. Green Building Council meeting in Chicago, IL.

“Forecasting: A Primer for the Small Business Entrepreneur,” presented with James E. Cox, Jr. April 14, 2010 at the Allied Academies’ Spring International Conference in New Orleans, LA.

“Are Renewable Portfolio Standards a Policy Cure-All? A Case Study of Illinois’ Experience,” presented January 30, 2010 at the 2010 William and Mary Environmental Law and Policy Review Symposium in Williamsburg, VA.

“Creating Partnerships between Universities and Industry,” presented November 19, 2009, at New Ideas in Educating a Workforce in Renewable Energy and Energy Efficiency in Albany, NY.

“Educating Illinois in Renewable Energy,” presented November 14, 2009 at the Illinois Science Teachers Association in Peoria, IL.

“Green Collar Jobs,” invited presentation October 14, 2009 at the 2009 Workforce Forum in Peoria, IL.

“The Role of Wind Power in Illinois,” presented March 4, 2009 at the Association of Illinois Electric Cooperatives Engineering Seminar in Springfield, IL.

“The Economic Benefits of Wind Farms,” presented January 30, 2009 at the East Central Illinois Economic Development District Meeting in Champaign, IL.

“Green Collar Jobs in Illinois,” presented January 6, 2009 at the Illinois Workforce Investment Board Meeting in Macomb, Illinois.

“Green Collar Jobs: What Lies Ahead for Illinois?” presented August 1, 2008 at the Illinois Employment and Training Association Conference.

“Mapping Broadband Access in Illinois,” presented October 16, 2007 at the Rural Telecon ’07 conference.

“A Managerial Approach to Using Error Measures to Evaluate Forecasting Methods,” presented October 15, 2007 at the International Academy of Business and Economics.

“Dollars and Sense: The Pros and Cons of Renewable Fuel,” presented October 18, 2006 at Illinois State University Faculty Lecture Series.

“Broadband Access in Illinois,” presented July 28, 2006 at the Illinois Association of Regional Councils Annual Meeting.

“Broadband Access in Illinois,” presented November 17, 2005 at the University of Illinois’ Connecting the e to Rural Illinois.

Selected Presentations (continued)

“Improving Forecasting Through Textbooks – A 25 Year Review,” with James E. Cox, Jr., presented June 14, 2005 at the 25th International Symposium on Forecasting.

“Telecommunications Demand Forecasting with Intermodal Competition, with Christopher Swann, presented April 2, 2004 at the Telecommunications Systems Management Conference 2004.

“Intermodal Competition,” with Christopher Swann, presented April 3, 2003 at the Telecommunications Systems Management Conference 2003.

“Intermodal Competition in Local Exchange Markets,” with Christopher Swann, presented June 26, 2002 at the 20th Annual International Communications Forecasting Conference.

“Assessing Retail Competition,” presented May 23, 2002 at the Institute for Regulatory Policy Studies’ Illinois Energy Policy for the 21st Century workshop.

“The Devil in the Details: An Analysis of Default Service and Switching,” with Eric Malm presented May 24, 2001 at the 20th Annual Advanced Workshop on Regulation and Competition.

“Forecasting Challenges for U.S. Telecommunications with Local Competition,” presented June 28, 1999 at the 19th International Symposium on Forecasting.

“Acceptance of Forecasting Principles in Forecasting Textbooks,” presented June 28, 1999 at the 19th International Symposium on Forecasting.

“Forecasting Challenges for Telecommunications With Local Competition,” presented June 17, 1999 at the 17th Annual International Communications Forecasting Conference.

“Measures of Market Competitiveness in Deregulating Industries,” with Eric Malm, presented May 28, 1999 at the 18th Annual Advanced Workshop on Regulation and Competition.

“Trends in Telecommunications Forecasting and the Impact of Deregulation,” Proceedings of EPRI’s 11th Forecasting Symposium, 1998.

“Forecasting in a Competitive Age: Utilizing Macroeconomic Forecasts to Accurately Predict the Demand for Services,” invited speaker, Institute for International Research Conference, September 29, 1997.

“Regulatory Fairness and Local Competition Pricing,” presented May 30, 1996 at the 15th Annual Advanced Workshop in Regulation and Public Utility Economics.

“Optimal Pricing For a Regulated Monopolist Facing New Competition: The Case of Bell Atlantic Special Access Demand,” presented May 28, 1992 at the Rutgers Advanced Workshop in Regulation and Public Utility Economics.

Grants

“SmartGrid for Schools 2018 and Energy Challenge,” with William Hunter, Illinois Science and Energy Innovation Foundation, RSP Award # A15-0092-002 - extended, January 2017, \$300,000.

“Energy Learning Exchange - Implementing Nationally Recognized Energy Curriculum and Credentials in Illinois,” Northern Illinois University, RSP Award # A17-0098, February, 2017, \$13,000.

“SmartGrid for Schools 2017 and Energy Challenge,” with William Hunter, Illinois Science and Energy Innovation Foundation, RSP Award # A15-0092-002 - extended, January 2017, \$350,000.

“Illinois Jobs Project,” University of California Berkeley, RSP Award # A16-0148, August, 2016, \$10,000.

“Energy Workforce Ready Through Building Performance Analysis,” Illinois Department of Commerce and Economic Opportunity through the Department of Labor, RSP # A16-0139, June, 2016, \$328,000 (grant was de-obligated before completion).

“SmartGrid for Schools 2016 and Smart Appliance Challenge,” with William Hunter, Brad Christenson and Jeritt Williams, Illinois Science and Energy Innovation Foundation, RSP Award # A15-0092-002, January 2016, \$450,000.

“SmartGrid for Schools 2015,” with William Hunter and Matt Aldeman, Illinois Science and Energy Innovation Foundation, RSP Award # A15-0092-001, February 2015, \$400,000.

“Economic Impact of Nuclear Plant Closings: A Response to HR 1146,” Illinois Department of Economic Opportunity, RSP Award # 14-025001 amended, January, 2015, \$22,000.

“Partnership with Midwest Renewable Energy Association for Solar Market Pathways” with Missy Nergard and Jin Jo, U.S. Department of Energy Award Number DE-EE0006910, October, 2014, \$109,469 (ISU Award amount).

“Renewable Energy for Schools,” with Matt Aldeman and Jin Jo, Illinois Department of Commerce and Economic Opportunity, Award Number 14-025001, June, 2014, \$130,001.

“SmartGrid for Schools 2014,” with William Hunter and Matt Aldeman, Illinois Science and Energy Innovation Foundation, RSP # 14B116, March 2014, \$451,701.

“WINDPOWER 2014 Conference Exhibit,” Illinois Department of Commerce and Economic Opportunity, RSP #14C167, March, 2014, \$95,000.

“Lake Michigan Offshore Wind Energy Buoy,” with Matt Aldeman, Illinois Clean Energy Community Foundation, Request ID 6435, November, 2013, \$90,000.

“Teaching Next Generation Energy Concepts with Next Generation Science Standards,” with William Hunter, Matt Aldeman and Amy Bloom, Illinois State Board of Education, RSP # 13B170A, October, 2013, second year, \$159,954; amended to \$223,914.

Grants (continued)

“Solar for Schools,” with Matt Aldeman, Illinois Green Economy Network, RSP # 13C280, August, 2013, \$66,072.

“Energy Learning Exchange Implementation Grant,” with William Hunter and Matt Aldeman, Illinois Department of Commerce and Economic Opportunity, Award Number 13-052003, June, 2013, \$350,000.

“Teaching Next Generation Energy Concepts with Next Generation Science Standards,” with William Hunter, Matt Aldeman and Amy Bloom, Illinois State Board of Education, RSP # 13B170, April, 2013, \$159,901.

“Illinois Sustainability Education SEP,” Illinois Department of Commerce and Economic Opportunity, Award Number 08-431006, March, 2013, \$225,000.

“Illinois Pathways Energy Learning Exchange Planning Grant,” with William Hunter and Matt Aldeman, Illinois State Board of Education (Source: U.S. Department of Education), RSP # 13A007, December, 2012, \$50,000.

“Illinois Sustainability Education SEP,” Illinois Department of Commerce and Economic Opportunity, Award Number 08-431005, June 2011, amended March, 2012, \$98,911.

“Wind for Schools Education and Outreach,” with Matt Aldeman, Illinois Department of Commerce and Economic Opportunity, Award Number 11-025001, amended February, 2012, \$111,752.

“A Proposal to Support Solar Energy Potential and

Job Creation for the State of Illinois Focused on Large Scale Photovoltaic System,” with Jin Jo (lead PI), Illinois Department of Commerce and Economic Opportunity, Award Number 12-025001, January 2012, \$135,000.

“National Database of Utility Rates and Rate Structure,” U.S. Department of Energy, Award Number DE-EE0005350TDD, 2011-2014, \$850,000.

“Illinois Sustainability Education SEP,” Illinois Department of Commerce and Economic Opportunity, Award Number 08-431005, June 2011, \$75,000.

“Illinois Pathways Energy Learning Exchange Planning Grant,” with William Hunter and Matt Aldeman, Illinois State Board of Education (Source: U.S. Department of Education), RSP # 13A007, December, 2012, \$50,000.

“Illinois Sustainability Education SEP,” Illinois Department of Commerce and Economic Opportunity, Award Number 08-431005, June 2011, amended March, 2012, \$98,911.

“Wind for Schools Education and Outreach,” with Matt Aldeman, Illinois Department of Commerce and Economic Opportunity, Award Number 11-025001, amended February, 2012, \$111,752.

“A Proposal to Support Solar Energy Potential and Job Creation for the State of Illinois Focused on Large Scale Photovoltaic System,” with Jin Jo (lead PI), Illinois Department of Commerce and Economic Opportunity, Award Number 12-025001, January 2012, \$135,000.

“National Database of Utility Rates and Rate Structure,” U.S. Department of Energy, Award Number DE-EE0005350TDD, 2011-2014, \$850,000.

“Illinois Sustainability Education SEP,” Illinois Department of Commerce and Economic Opportunity, Award Number 08-431005, June 2011, \$75,000.

“Wind for Schools Education and Outreach,” with Matt Aldeman, Illinois Department of Commerce and Economic Opportunity, Award Number 11-025001, March 2011, \$190,818.

“Using Informal Science Education to Increase Public Knowledge of Wind Energy in Illinois,” with Amy Bloom and Matt Aldeman, Scott Elliott Cross-Disciplinary Grant Program, February 2011, \$13,713.

“Wind Turbine Market Research,” with Matt Aldeman, Illinois Manufacturers Extension Center, May, 2010, \$4,000.

“Petco Resource Assessment,” with Matt Aldeman, Petco Petroleum Co., April, 2010 amended August 2010 \$34,000; original amount \$18,000.

“Wind for Schools Education and Outreach,” with Anthony Lornbach and Matt Aldeman, Scott Elliott Cross-Disciplinary Grant Program, February, 2010, \$13,635.

“IGA IFA/ISU Wind Due Diligence,” Illinois Finance Authority, November, 2009, \$8,580 amended December 2009; original amount \$2,860.

“Green Industry Business Development Program, with the Shaw Group and Illinois Manufacturers Extension Center, Illinois Department of Commerce and Economic Opportunity, Award Number 09-021007, August 2009, \$245,000.

“Wind Turbine Workshop Support,” Illinois Department of Commerce and Economic Opportunity, June 2009, \$14,900.

“Illinois Wind Workers Group,” with Randy Winter, U.S. Department of Energy, Award Number DE-EE0000507, 2009-2011, \$107,941.

“Wind Turbine Supply Chain Study,” with J. Lon Carlson and James E. Payne, Illinois Department of Commerce and Economic Opportunity, Award Number 09-021003, April 2009, \$125,000.

“Renewable Energy Team Travel to American Wind Energy Association WindPower 2009 Conference, Center for Mathematics, Science and Technology, February 2009, \$3,005.

“Renewable Energy Educational Lab Equipment,” with Randy Winter and David Kennell, Illinois Clean Energy Community Foundation (peer-reviewed), February, 2008, \$232,600.

“Proposal for New Certificate Program in Electricity, Natural Gas and Telecommunications Economics,” with James E. Payne, Extended Learning Program Grant, April, 2007, \$29,600.

Grants (continued)

“Illinois Broadband Mapping Study,” with J. Lon Carlson and Rajeev Goel, Illinois Department of Commerce and Economic Opportunity, Award Number 06-205008, 2006-2007, \$75,000.

“Illinois Wind Energy Education and Outreach Project,” with David Kennell and Randy Winter, U.S. Department of Energy, Award Number DE-FG36-06GO86091, 2006-2010, \$990,000.

“Wind Turbine Installation at Illinois State University Farm,” with Doug Kingman and David Kennell, Illinois Clean Energy Community Foundation (peer-reviewed), May, 2004, \$500,000.

“Illinois State University Wind Measurement Project,” Doug Kingman and David Kennell, Illinois Clean Energy Community Foundation (peer-reviewed), with August, 2003, \$40,000.

“Illinois State University Wind Measurement Project,” with Doug Kingman and David Kennell, NEG Micon matching contribution, August, 2003, \$65,000.

“Distance Learning Technology Program,” Illinois State University Faculty Technology Support Services, Summer 2002, \$3,000.

“Providing an Understanding of Telecommunications Technology By Incorporating Multimedia into Economics 235,” Instructional Technology Development Grant (peer-reviewed), January 15, 2001, \$1,400.

“Using Real Presenter to create a virtual tour of GTE’s Central Office,” with Jack Chizmar, Instructional Technology Literacy Mentoring Project Grant (peer-reviewed), January 15, 2001, \$1,000.

“An Empirical Study of Telecommunications Industry Forecasting Practices,” with James E. Cox, College of Business University Research Grant (peer-reviewed), Summer, 1999, \$6,000.

“Ownership Form and the Efficiency of Electric Utilities: A Meta-Analytic Review” with L. Dean Hiebert, Institute for Regulatory Policy Studies research grant (peer-reviewed), August 1998, \$6,000.

Total Grants: \$7,740,953

External Funding

Corporate Funding for Institute for Regulatory Policy Studies, Ameren (\$7,500), Aqua Illinois (\$7,500); Commonwealth Edison (\$7,500); Exelon (\$7,500); Illinois American Water (\$7,500); Midcontinent ISO (\$7,500); NICOR Energy (\$7,500); People Gas Light and Coke (\$7,500); PJM Interconnect (\$7,500); Fiscal Year 2017, \$67,500 total.

Workshop Surplus for Institute for Regulatory Policy Studies, with Adrienne Ohler, Fiscal Year 2017, \$18,342.

Corporate Funding for Institute for Regulatory Policy Studies, Ameren (\$7,500), Aqua Illinois (\$7,500); Commonwealth Edison (\$7,500); Exelon (\$7,500); Illinois American Water (\$7,500) ITC Holdings (\$7,500); Midcontinent ISO (\$7,500); NICOR Energy (\$7,500); People Gas Light and Coke (\$7,500); PJM Interconnect (\$7,500); Fiscal Year 2017, \$75,000 total.

Workshop Surplus for Institute for Regulatory Policy Studies, with Adrienne Ohler, Fiscal Year 2016, \$19,667.

Corporate Funding for Energy Learning Exchange, Calendar Year 2016, \$53,000.

Corporate Funding for Institute for Regulatory Policy Studies, Ameren (\$7,500), Aqua Illinois (\$7,500); Commonwealth Edison (\$7,500); Exelon/Constellation NewEnergy (\$7,500); Illinois American Water (\$7,500) ITC Holdings (\$7,500); Midcontinent ISO (\$7,500); NICOR Energy (\$7,500); People Gas Light and Coke (\$7,500); PJM Interconnect (\$7,500); Utilities, Inc. (\$7,500) Fiscal Year 2016, \$82,500 total.

Workshop Surplus for Institute for Regulatory Policy Studies, with Adrienne Ohler, Fiscal Year 2015, \$15,897.

Corporate Funding for Institute for Regulatory Policy Studies, Ameren (\$7,500), Alliance Pipeline (\$7,500); Aqua Illinois (\$7,500); AT&T (\$7,500); Commonwealth Edison (\$7,500); Exelon/Constellation NewEnergy (\$7,500); Illinois American Water (\$7,500) ITC Holdings (\$7,500); Midcontinent ISO (\$7,500); NICOR Energy (\$7,500); People Gas Light and Coke (\$7,500); PJM Interconnect (\$7,500); Fiscal Year 2015, \$90,000 total.

Corporate Funding for Energy Learning Exchange, Calendar Year 2014, \$55,000.

Workshop Surplus for Institute for Regulatory Policy Studies, with Adrienne Ohler, Fiscal Year 2014, \$12,381.

External Funding (continued)

Corporate Funding for Institute for Regulatory Policy Studies, Ameren (\$7,500), Alliance Pipeline (\$7,500); Aqua Illinois (\$7,500); AT&T (\$7,500); Commonwealth Edison (\$7,500); Constellation NewEnergy (\$7,500); Illinois American Water (\$7,500) ITC Holdings (\$7,500); Midwest Energy Efficiency Alliance (\$4,500); Midwest Generation (\$7,500); MidWest ISO (\$7,500); NICOR Energy (\$7,500); People Gas Light and Coke (\$7,500); PJM Interconnect (\$7,500); Fiscal Year 2014, \$102,000 total.

Corporate Funding for Energy Learning Exchange, Calendar Year 2013, \$53,000.

Workshop Surplus for Institute for Regulatory Policy Studies, with Adrienne Ohler, Fiscal Year 2013, \$17,097.

Corporate Funding for Institute for Regulatory Policy Studies, Ameren (\$7,500), Alliance Pipeline (\$7,500); Aqua Illinois (\$7,500); AT&T (\$7,500); Commonwealth Edison (\$7,500); Constellation NewEnergy (\$7,500); Illinois American Water (\$7,500) ITC Holdings (\$7,500); Midwest Generation (\$7,500); MidWest ISO (\$7,500); NICOR Energy (\$7,500); People Gas Light and Coke (\$7,500); PJM Interconnect (\$7,500); Fiscal Year 2013, \$97,500 total.

Corporate Funding for Illinois Wind Working Group, Calendar Year 2012, \$29,325.

Workshop Surplus for Institute for Regulatory Policy Studies, with Adrienne Ohler, Fiscal Year 2012, \$16,060.

Corporate Funding for Institute for Regulatory Policy Studies, Alliance Pipeline (\$7,500); Aqua Illinois (\$7,500); AT&T (\$7,500); Commonwealth Edison (\$7,500); Constellation NewEnergy (\$7,500); Illinois American Water (\$7,500) ITC Holdings (\$7,500); Midwest Generation (\$7,500); MidWest ISO (\$7,500); NICOR Energy (\$7,500); People Gas Light and Coke (\$7,500); PJM Interconnect (\$7,500); Fiscal Year 2012, \$90,000 total.

Corporate Funding for Illinois Wind Working Group, Calendar Year 2011, \$57,005.

Workshop Surplus for Institute for Regulatory Policy Studies, with Adrienne Ohler, Fiscal Year 2011, \$13,562.

Corporate Funding for Institute for Regulatory Policy Studies, Alliance Pipeline (\$7,500); Aqua Illinois (\$7,500); AT&T (\$7,500); Commonwealth Edison (\$7,500); Constellation NewEnergy (\$7,500); Illinois American Water (\$7,500) ITC Holdings (\$7,500); Midwest Generation (\$7,500); MidWest ISO (\$7,500); NICOR Energy (\$7,500); People Gas Light and Coke (\$7,500); PJM Interconnect (\$7,500); Fiscal Year 2011, \$90,000 total.

Corporate Funding for Center for Renewable Energy, Calendar Year 2010, \$50,000.

Corporate Funding for Illinois Wind Working Group, Calendar Year 2010, \$49,000.

Workshop Surplus for Institute for Regulatory Policy Studies, with Lon Carlson, Fiscal Year 2010, \$17,759.

Corporate Funding for Institute for Regulatory Policy Studies, Alliance Pipeline (\$7,500); Ameren (\$7,500); AT&T (\$7,500); Commonwealth Edison (\$7,500); Constellation NewEnergy (\$7,500); ITC Holdings (\$7,500); Midwest Generation (\$7,500); MidWest ISO (\$7,500); NICOR Energy (\$7,500); People Gas Light and Coke (\$7,500); PJM Interconnect (\$7,500); Fiscal Year 2010, \$82,500 total.

Corporate Funding for Illinois Wind Working Group, Calendar Year 2009, \$57,140.

Workshop Surplus for Institute for Regulatory Policy Studies, with Lon Carlson, Fiscal Year 2009, \$21,988.

Corporate Funding for Institute for Regulatory Policy Studies, Alliance Pipeline (\$7,500); Ameren (\$7,500); AT&T (\$7,500); Commonwealth Edison (\$7,500); Constellation NewEnergy (\$7,500); MidAmerican Energy (\$7,500); Midwest Generation (\$7,500); MidWest ISO (\$7,500); NICOR Energy (\$7,500); People Gas Light and Coke (\$7,500); PJM Interconnect (\$7,500); Fiscal Year 2009, \$82,500 total.

Corporate Funding for Center for Renewable Energy, Calendar Year 2008, \$157,500.

Corporate Funding for Illinois Wind Working Group, Calendar Year 2008, \$38,500.

Workshop Surplus for Institute for Regulatory Policy Studies, with Lon Carlson, Fiscal Year 2008, \$28,489.

Corporate Funding for Institute for Regulatory Policy Studies, Alliance Pipeline (\$5,000); Ameren (\$5,000); AT&T (\$5,000); Commonwealth Edison (\$5,000); Constellation NewEnergy (\$5,000); MidAmerican Energy (\$5,000); Midwest Generation (\$5,000); MidWest ISO (\$5,000); NICOR Energy (\$5,000); Peabody Energy (\$5,000); People Gas Light and Coke (\$5,000); PJM Interconnect (\$5,000); Fiscal Year 2008, \$60,000 total.

Corporate Funding for Illinois Wind Working Group, Calendar Year 2007, \$16,250.

Workshop Surplus for Institute for Regulatory Policy Studies, with Lon Carlson, Fiscal Year 2007, \$19,403.

Corporate Funding for Institute for Regulatory Policy Studies, AARP (\$3,000), Alliance Pipeline (\$5,000), Ameren (\$5,000); Citizens Utility Board (\$5,000); Commonwealth Edison (\$5,000); Constellation NewEnergy (\$5,000); MidAmerican Energy (\$5,000); Midwest Generation (\$5,000); MidWest ISO (\$5,000); NICOR Energy (\$5,000); Peabody Energy (\$5,000), People Gas Light and Coke (\$5,000); PJM Interconnect (\$5,000); SBC (\$5,000); Verizon (\$5,000); Fiscal Year 2007, \$73,000 total.

Workshop Surplus for Institute for Regulatory Policy Studies, with Lon Carlson, Fiscal Year 2006, \$13,360.

External Funding (continued)

Corporate Funding for Institute for Regulatory Policy Studies, AARP (\$1,500), Alliance Pipeline (\$2,500), Ameren (\$5,000); Citizens Utility Board (\$5,000); Commonwealth Edison (\$5,000); Constellation NewEnergy (\$5,000); DTE Energy (\$5,000); MidAmerican Energy (\$5,000); Midwest Generation (\$5,000); MidWest ISO (\$5,000); NICOR Energy (\$5,000); Peabody Energy (\$2,500), People Gas Light and Coke (\$5,000); PJM Interconnect (\$5,000); SBC (\$5,000); Verizon (\$5,000); Fiscal Year 2006, \$71,500 total.

Workshop Surplus for Institute for Regulatory Policy Studies, with L. Dean Hiebert, Fiscal Year 2005, \$12,916.

Corporate Funding for Institute for Regulatory Policy Studies, with L. Dean Hiebert, AmerenCIPS (\$5,000); Citizens Utility Board (\$5,000); Commonwealth Edison (\$5,000); Constellation NewEnergy (\$5,000); Illinois Power (\$5,000); MidAmerican Energy (\$5,000); Midwest Generation (\$5,000); MidWest ISO (\$5,000); NICOR Energy (\$5,000); People Gas Light and Coke (\$5,000); PJM Interconnect (\$5,000); SBC (\$2,500); Verizon (\$2,500); Fiscal Year 2005, \$60,000 total.

Workshop Surplus for Institute for Regulatory Policy Studies, with L. Dean Hiebert, Fiscal Year 2004, \$17,515.

Corporate Funding for Institute for Regulatory Policy Studies, with L. Dean Hiebert, AmerenCIPS (\$5,000); Commonwealth Edison (\$5,000); Constellation NewEnergy (\$5,000); Illinois Power (\$5,000); MidAmerican Energy (\$5,000); Midwest Generation (\$5,000); NICOR Energy (\$5,000); People Gas Light and Coke (\$5,000); PJM Interconnect (\$5,000); Fiscal Year 2004, \$45,000 total.

Workshop Surplus for Institute for Regulatory Policy Studies, with L. Dean Hiebert, Fiscal Year 2003, \$8,300.

Corporate Funding for Institute for Regulatory Policy Studies, with L. Dean Hiebert, AmerenCIPS (\$5,000); AT&T (\$2,500); Commonwealth Edison (\$5,000); Illinois Power (\$5,000); MidAmerican Energy (\$5,000); NICOR Energy (\$5,000); People Gas Light and Coke (\$5,000); Fiscal Year 2003, \$32,500 total.

Workshop Surplus for Institute for Regulatory Policy Studies, with L. Dean Hiebert, Calendar Year 2002, \$15,700.

Corporate Funding for Institute for Regulatory Policy Studies, with L. Dean Hiebert, AmerenCIPS (\$2,500); AT&T (\$5,000); Commonwealth Edison (\$2,500); Illinois Power (\$2,500); MidAmerican Energy (\$2,500); NICOR Energy (\$2,500); People Gas Light and Coke (\$2,500); Calendar Year 2002, \$17,500 total.

Corporate Funding for International Communications Forecasting Conference, National Economic Research Associates (\$10,000); Taylor Nelson Sofres Telecoms (\$10,000); Calendar Year 2002, \$20,000 total

Corporate Funding for Institute for Regulatory Policy Studies, with L. Dean Hiebert, AmerenCIPS (\$5,000); AT&T (\$5,000); Commonwealth Edison (\$5,000); Illinois Power (\$5,000); MidAmerican Energy (\$5,000); NICOR Energy (\$5,000); People Gas Light and Coke (\$5,000); Calendar Year 2001, \$35,000 total.

Workshop Surplus for Institute for Regulatory Policy Studies, with L. Dean Hiebert, Calendar Year 2001, \$19,400.

Corporate Funding for International Communications Forecasting Conference, National Economic Research Associates (\$10,000); Taylor Nelson Sofres Telecoms (\$10,000); SAS Institute (\$10,000); Calendar Year 2001, \$30,000 total.

Corporate Funding for Institute for Regulatory Policy Studies, with L. Dean Hiebert, AmerenCIPS (\$5,000); AT&T (\$5,000); Commonwealth Edison (\$5,000); Illinois Power (\$5,000); MidAmerican Energy (\$5,000); NICOR Energy (\$5,000); People Gas Light and Coke (\$5,000); Calendar Year 2000, \$35,000 total.

Workshop Surplus for Institute for Regulatory Policy Studies, with L. Dean Hiebert, Calendar Year 2000, \$20,270.

Corporate Funding for International Communications Forecasting Conference, National Economic Research Associates (\$10,000); Taylor Nelson Sofres Telecoms (\$10,000); Calendar Year 2000, \$20,000 total.

Corporate Funding for Institute for Regulatory Policy Studies, with L. Dean Hiebert, AmerenCIPS (\$5,000); AT&T (\$5,000); Commonwealth Edison (\$5,000); Illinois Power (\$5,000); MidAmerican Energy (\$5,000); NICOR Energy (\$5,000); People Gas Light and Coke (\$5,000); Calendar Year 1999, \$35,000 total.

Workshop Surplus for Institute for Regulatory Policy Studies, with L. Dean Hiebert, Calendar Year 1999, \$10,520.

Corporate Funding for International Communications Forecasting Conference, National Economic Research Associates (\$10,000); PNR Associates (\$10,000); Calendar Year 1999, \$20,000 total.

Corporate Funding for Institute for Regulatory Policy Studies, with L. Dean Hiebert, AmerenCIPS (\$5,000); CILCO (\$5,000); Commonwealth Edison (\$5,000); Illinois Power (\$5,000); MidAmerican Energy (\$5,000); People Gas Light and Coke (\$5,000); Calendar Year 1998, \$30,000 total.

Workshop Surplus for Institute for Regulatory Policy Studies, with L. Dean Hiebert, Calendar Year 1998, \$44,334.

Corporate Funding for International Communications Forecasting Conference, National Economic Research Associates (\$10,000); PNR Associates (\$10,000); Calendar Year 1998, \$20,000 total.

Corporate Funding for Institute for Regulatory Policy Studies, with L. Dean Hiebert, AmerenCIPS (\$5,000); CILCO (\$5,000); Commonwealth Edison (\$5,000); Illinois Power (\$5,000); MidAmerican Energy (\$5,000); People Gas Light and Coke (\$5,000); Calendar Year 1997, \$30,000 total.

Workshop Surplus for Institute for Regulatory Policy Studies, with L. Dean Hiebert, Calendar Year 1997, \$19,717.

Total External Funding: \$2,492,397



by David G. Loomis
Strategic Economic Research, LLC
strategiceconomic.com
815-905-2750