

# AUGUSTA SUPPLY LINE PROJECT CHANGE ORDER #1

FOR THE  
BRACKEN COUNTY WATER DISTRICT

OCTOBER 2021

PREPARED BY:

**COMMISSIONERS:**

ANTHONY HABERMEHL - CHAIRMAN  
DALE APPELMAN  
LOUIE KING  
EDDIE KERN  
TIMOTHY SWEENEY  
DIANA MORAN - OFFICE MANAGER  
MICHAEL BROTHERS - FIELD MANAGER



222 East Main Street, Ste. 1 • Georgetown, KY 40324

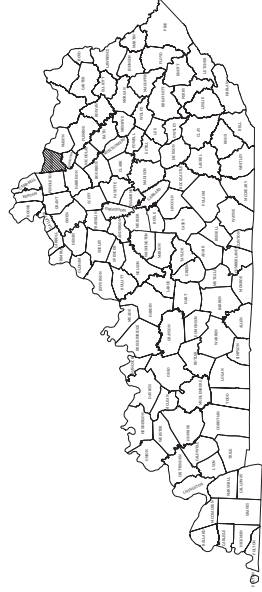

PROJECT NO. 19025







PROJECT #: 19025  
 DATE: SEPTEMBER 2021  
 PROJECT MGR: PBR  
 DRAWN BY: GNV  
 CHECKED BY: BKL

**BE BLUEGRASS ENGINEERING, P.L.L.C.**  
 222 East Main Street, Ste. 1 - Georgetown, KY 40324

**AUGUSTA SUPPLY LINE  
 CO 1  
 AERIAL PLAN VIEW  
 STA. 10+00 TO STA. 30+45**

NO.	DATE	REVISIONS	BY

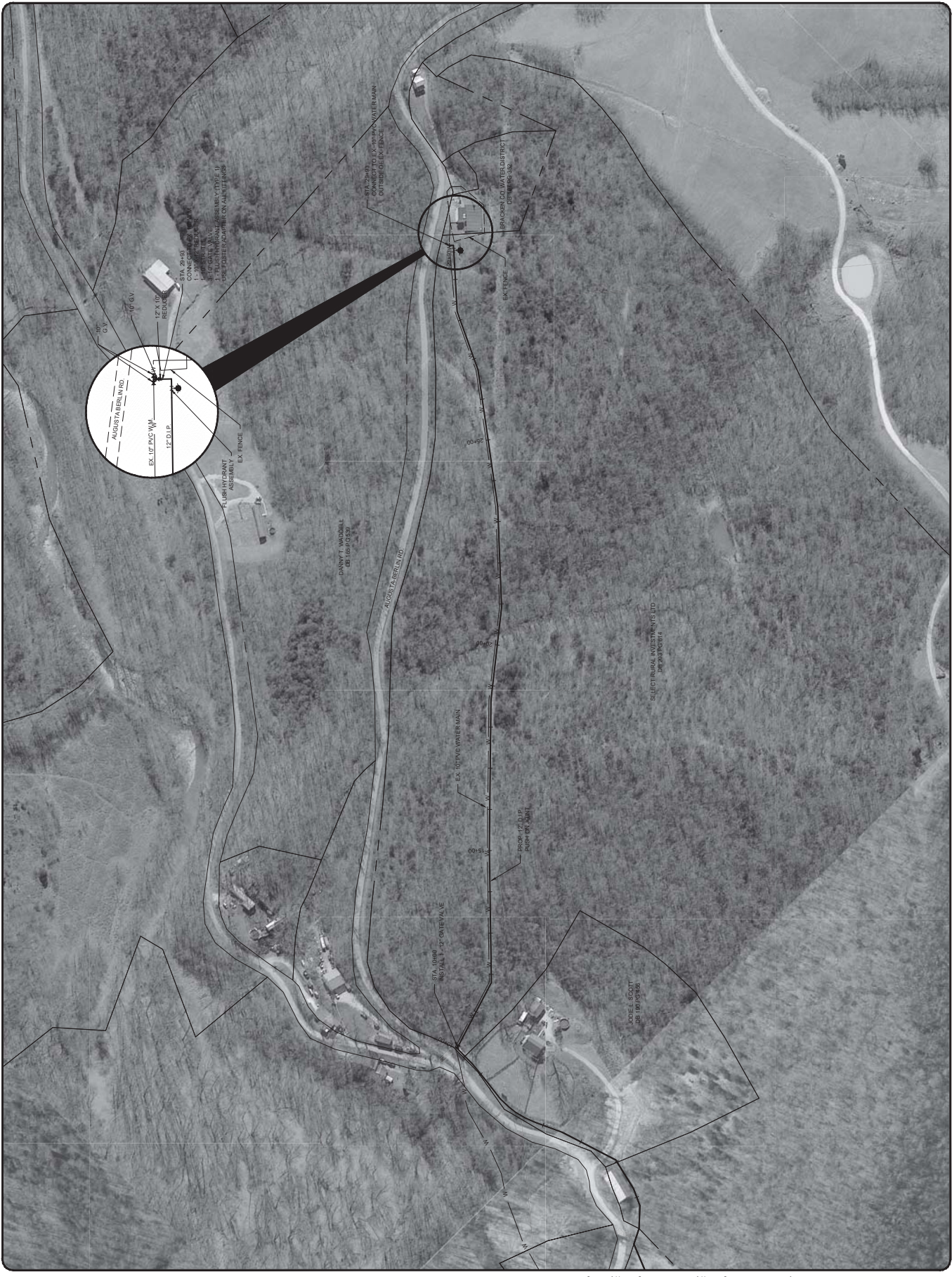

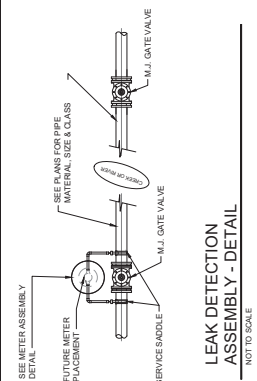

- NOTE:**
- CONTRACTOR IS RESPONSIBLE FOR ALL PLUMBING
  - SEE SPECIFICATIONS REGARDING SPECIFIC MAKE
  - MODEL TYPE AS LISTED IN SPECIFICATIONS
  - METER BOX SEE SPECIFICATIONS
  - METER-SEE SPECIFICATIONS
  - METER-SEE SPECIFICATIONS
  - TRACER WIRE TO BE CONNECTED TO WATER MAIN AND TERMINATING IN THE METER BOX
  - SERVICE SADDLE-SEE SPECIFICATION

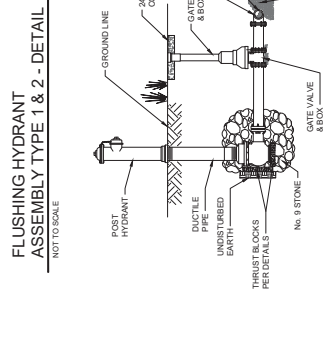
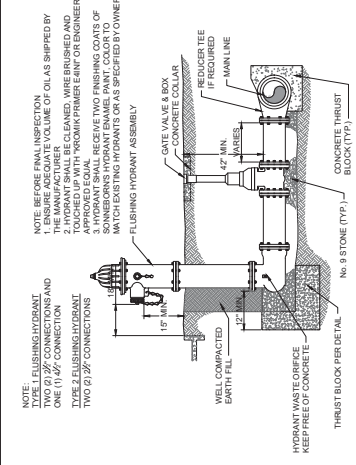
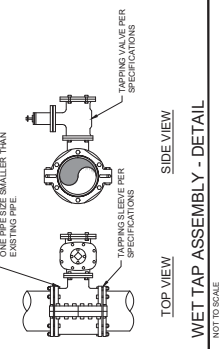
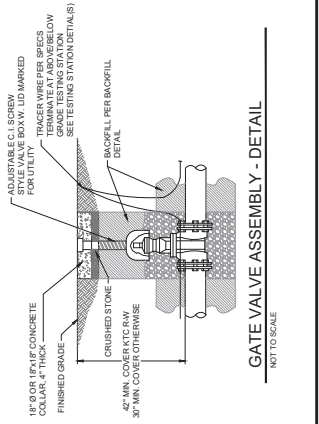
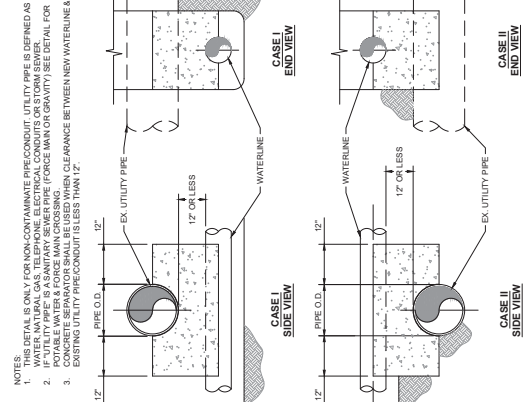
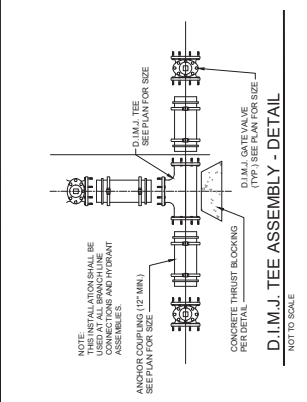
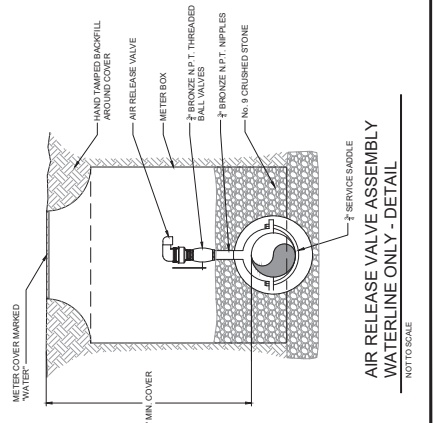
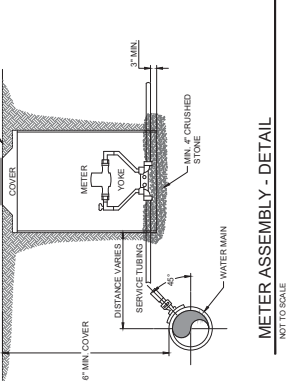

NO.	DATE	REVISIONS	BY

STANDARD DETAILS - WATER LINES  
AUGUSTA SUPPLY LINE PROJECT  
CO 1

**BLUEGRASS ENGINEERING, INC.**  
222 East Main Street, Ste. 1 - Georgetown, KY 40324

PROJECT # 19225  
DATE JUNE 2020  
PROJECT NO. PBR  
DRAWN BY: GRV  
CHECKED BY: MRC



THIS DRAWING HAS BEEN PREPARED AT THE SCALE INDICATED. REPRODUCTION OF THIS DRAWING MAY BE MADE BY ANY PERSON WITHOUT THE WRITTEN PERMISSION OF BLUEGRASS ENGINEERING, P.L.C. AND ACTING UNDER THE DIRECTION OF A LICENSED ENGINEER. IN PROCEEDING WITH THIS DRAWING UNDER THE DIRECTION OF A LICENSED ENGINEER. PROJECTS\broken County Water District\19225 - Augusta Supply Line\DWG\STANDARD DETAILS - WATERLINES.dwg



**DETAIL NOTES:**

- COVER UP TO AND INCLUDING ZONE 4 SHALL BE ESTABLISHED BEFORE TRENCH EXCAVATION.
- ZONE 4 - 6" MIN. CONSOLIDATION EARTH BACKFILL INCLUDING TOPSOIL, NO ROCK ALLOWED.
- ZONE 3 - CONSOLIDATED SOIL (NO ROCK GREATER THAN 6" DIAMETER) NO. 9 OR 7.5 STONE
- ZONE 2 - FROM THE SPRINGLINE OF THE PIPE TO A DEPTH OF 12" MIN. THE SAME MATERIAL AS SPECIFIED FOR ZONE 3 SHALL BE USED. COMPACTED IN AREAS SUBJECT TO TRAFFIC.
- ZONE 1 - BEDDING MATERIAL IN EARTH EXCAVATION AREAS SHALL BE CLEAN EARTH, FREE FROM ROCKS, DEBRIS OR OTHER FOREIGN MATERIAL. THE CONTRACTOR SHALL PROVIDE BEDDING MATERIAL AND LEVEL AS ENCOUNTERED.

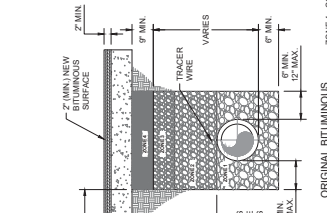
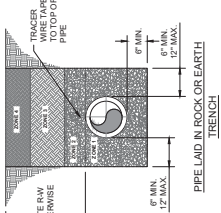

**PIPE BACKFILL - DETAIL**  
NOT TO SCALE

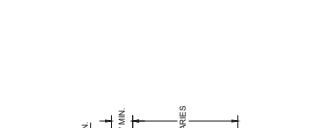

**PIPE BACKFILL - DETAIL**  
NOT TO SCALE

**THRUST BLOCK SCHEDULE**

PIPE SIZE	3/4" BEND			45° BEND			20° BEND			11° BEND			TELE BEND SOIL				
	REINFORCING D	W	L	REINFORCING D	W	L	REINFORCING D	W	L	REINFORCING D	W	L	REINFORCING D	W	L		
4"	3.750	21	18	30	10	18	14	1.000	06	16	12	12	060	02	12	12	
6"	7.000	39	16	42	24	3.750	18	30	18	2.000	11	16	12	12	12	12	
8"	12.200	61	24	42	42	7.500	24	36	30	4.000	30	24	24	24	24	24	
10"	20.000	148	24	60	42	10.500	24	42	36	6.000	44	24	36	24	24	24	
12"	30.000	278	30	72	60	15.750	148	30	54	7.500	69	30	36	24	24	24	
14"	39.000	433	36	78	72	20.000	222	36	60	10.000	117	36	42	36	24	27.500	
16"	49.000	635	42	84	84	27.500	326	42	66	14.000	161	42	48	42	7.500	63	
																30	37.750
																44	43
																48	44
																51	45
																54	46
																57	47
																60	48
																63	49
																66	50
																69	51
																72	52
																75	53
																78	54
																81	55
																84	56
																87	57
																90	58
																93	59
																96	60
																99	61
																102	62
																105	63
																108	64
																111	65
																114	66
																117	67
																120	68
																123	69
																126	70
																129	71
																132	72
																135	73
																138	74
																141	75
																144	76
																147	77
																150	78
																153	79
																156	80
																159	81
																162	82
																165	83
																168	84
																171	85
																174	86
																177	87
																180	88
																183	89
																186	90
																189	91
																192	92
																195	93
																198	94
																201	95
																204	96
																207	97
																210	98
																213	99
																216	100

NOTE: CONCRETE SHALL BE MIN. 40% PSI. SEE PLAN SHEET FOR SIZE, MATERIAL, & LOCATION OF PIPE. SIZES OF ALL TRENCHES TO BE UNDISTURBED SOIL. TRENCH DEPTH TO MAY NOT BE SMALLER THAN SPECIFIED. ALL TRENCHES SHALL BE UNDISTURBED SOIL. PLACE CONCRETE ANCHORS AS SHOWN. ALL FITTINGS SHALL BE WRAPPED IN PLASTIC WRAP. GRP FITTINGS SHALL BE USED ON ALL FITTINGS.

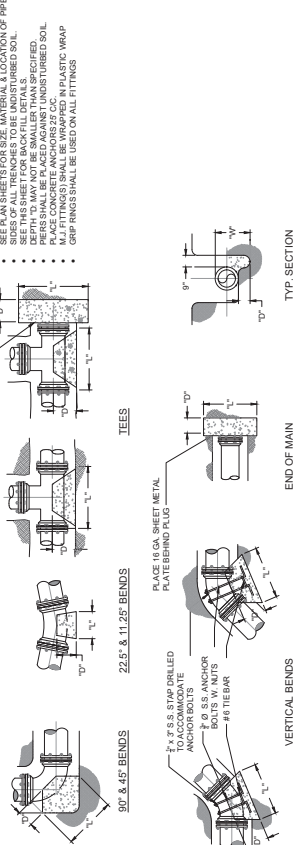

**CONCRETE THRUST BLOCK - DETAIL**  
NOT TO SCALE

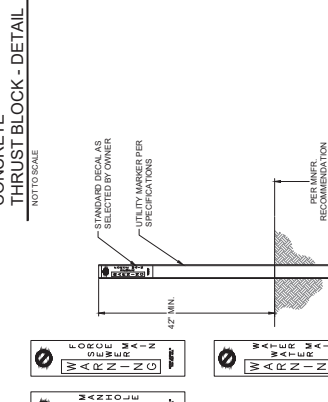

**UTILITY MARKER - DETAIL**  
NOT TO SCALE

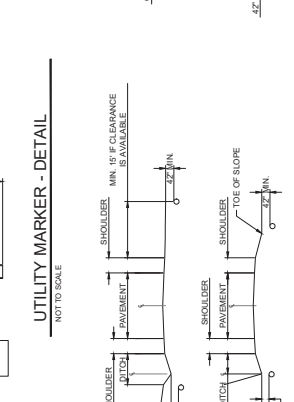

**UTILITY PIPELINE WITHIN KTC ROW - DETAIL**  
NOT TO SCALE

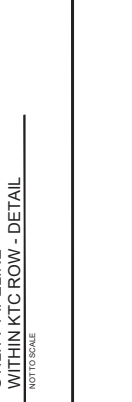

**PIPE BACKFILL - DETAIL**  
NOT TO SCALE

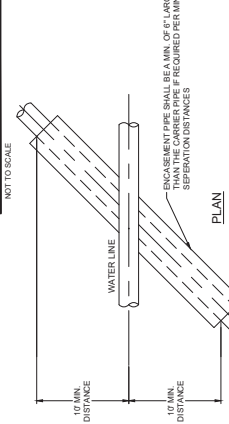

**POTABLE WATER LINE & FORCE MAIN CROSSING - DETAIL**  
NOT TO SCALE

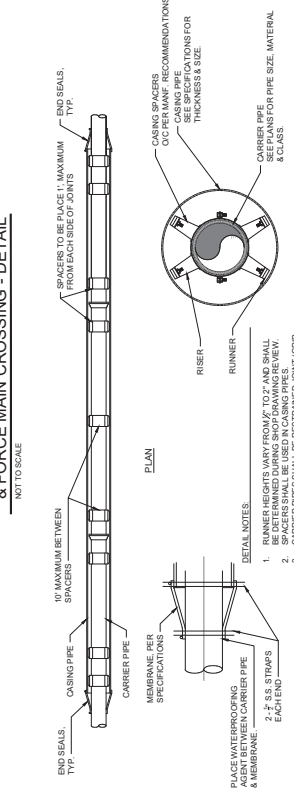

**CASING - DETAIL**  
NOT TO SCALE

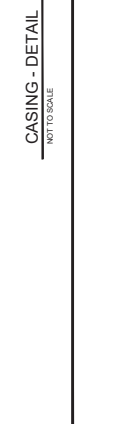

NO.	DATE	REVISIONS	BY

THIS DRAWING HAS BEEN PREPARED AT THE SCALE INDICATED. REPRODUCTION OF THIS DRAWING MAY BE MADE FOR PERSONAL USE ONLY. ANY REPRODUCTION FOR OTHER PURPOSES WITHOUT WRITTEN PERMISSION FROM BLUEGRASS ENGINEERING, P.L.C. AND ACTING UNDER THE DIRECTION OF A LICENSED ENGINEER. PROJECT NO. 202207

NO.	DATE	REVISIONS	BY

STANDARD DETAILS - EROSION  
 AUGUSTA SUPPLY LINE PROJECT  
 CO 1



PROJECT #: 19025  
 DATE: JUNE 2020  
 PROJECT NO.: PBR  
 DRAWN BY: GRV  
 CHECKED BY: MRC



05

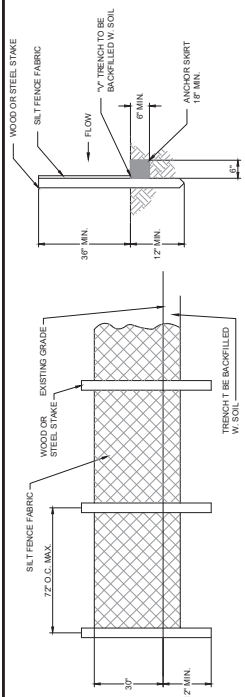

SILT FENCE - DETAIL  
 NOT TO SCALE

- NOTES:**
- SILT FENCE FABRIC SHALL BE PURCHASED IN A CONTINUOUS ROLL AND CUT TO THE LENGTH OF THE OF THE SPACING BETWEEN STAKES SHALL BE 3 FEET MIN. OVERLAP AND SECURELY SEALED.
  - POSTS SHALL BE AT LEAST 3 FEET IN LENGTH.
  - WOOD POSTS SHALL BE 2 INCHES BY 2 INCHES OR EQUIVALENT STEEL POSTS SHALL BE 100 LBS PER LINEAR FOOT.
  - IF REQUIRED A WIRE MESH SUPPORT FENCE SHALL BE FASTENED SECURELY TO THE UPOPER SIDE OF THE POSTS AND EXTEND INTO THE TRENCH A MINIMUM OF 2 INCHES AND SHALL NOT EXTEND MORE THAN 36 INCHES ABOVE THE TOP OF THE TRENCH.
  - TURN SILT FENCE UP SLOPE AT ENDS.

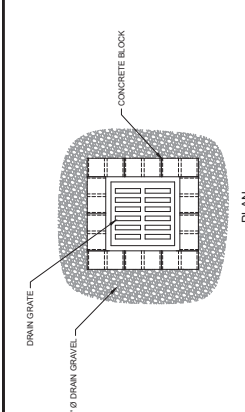

DROP INLET PROTECTION - DETAIL  
 NOT TO SCALE

- NOTES:**
- DROP INLET PROTECTION ARE TO BE USED FOR NEARBY LEVEL DRAINAGE AREAS.
  - EXCAVATE A BASIN OF SUFFICIENT SIZE ADJACENT TO THE DROP INLET.
  - CONCRETE BLOCKS SHALL BE SET IN A GRAVEL BED AND THE ELEVATION DOWN SLOPE TO PREVENT RUNOFF FROM BYPASSING THE INLET STRUCTURE.
  - TEMPORARY DIME MAY BE NECESSARY ON THE DOWNSLOPE SIDE OF THE STRUCTURE.

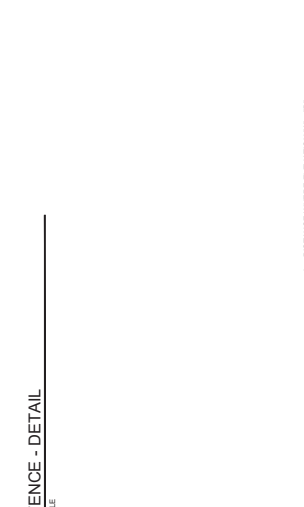

ROCK CHECK DAM - DETAIL  
 NOT TO SCALE

- NOTES:**
- ROCK CHECK DAMS SHOULD BE CONSTRUCTED OF GRADED 3 TO 10 INCH STONE. MECHANICAL OR HAND PLACEMENTS SHALL BE REQUIRED TO ENSURE COMPLETE COVERAGE OF THE ENTIRE WIDTH OF THE CHANNEL AND THAT THE CENTER OF THE DAM IS LOWER THAN THE SIDES.
  - WALK OFF THE DAM.

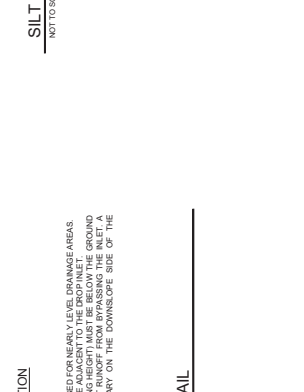

CURB INLET SEDIMENT BARRIER - DETAIL  
 NOT TO SCALE

- NOTES:**
- USE BLOCK AND GRAVEL TYPE SEDIMENT BARRIER WHEN CURB INLET IS LOCATED IN GENTLY SLOPING STREET.
  - SEGMENT WHERE WATER CAN FLOW AND ALLOW SEDIMENT TO SEPARATE FROM RUNOFF.
  - BARRIER SHALL ALLOW FOR OVERFLOW FROM SEVERE STORMEVENT.
  - REMOVED FROM THE TRAVELED WAY IMMEDIATELY.



STABILIZED CONSTRUCTION ENTRANCE - DETAIL  
 NOT TO SCALE

- NOTES:**
- A STABILIZED ENTRANCE PAD OF CRUSHED STONE SHALL BE LOCATED WHERE TRAFFIC WILL ENTER OR LEAVE THE CONSTRUCTION SITE ONTO A PUBLIC STREET.
  - THE STABILIZED ENTRANCE SHALL BE BASED FOR THE CONSTRUCTION ENTRANCE.
  - TREES, STAMPS, ROOTS, BRUSH, WEEDS, AND OTHER OBJECTIONABLE MATERIALS SHALL BE REMOVED FROM THE ENTRANCE.
  - UNDESIRABLE MATERIAL SHALL BE REMOVED FROM THE ROADWAY AND PARKING AREAS.
  - GRADING, SURFACE PREPARATION, AND COMPACTION SHALL BE DONE AS NEEDED. FILL MATERIAL SHALL BE COMPACTED AND EARTHWORKING EQUIPMENT SHALL BE OPERATED IN THE AREAS TO BE STABILIZED.
  - THE STABILIZED ENTRANCE SHALL BE GRADIENT TO THE ELEVATION AS SHOWN.
  - ALL CUTS AND FILLS SHALL BE 2:1 OR FLATTER TO THE EXTENT POSSIBLE.
  - WATERBARRIERS OR BARRIERS MAY BE USED TO CONTROL SURFACE RUNOFF.

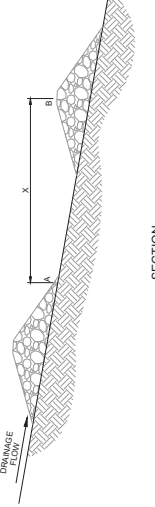

EROSION CONTROL NOTES

- EROSION CONTROL NOTES:**
- A KROSSLER STORMWATER PERMIT IS REQUIRED. COVERAGE STARTS WHEN THE KY DIVISION OF WATER ACKNOWLEDGES RECEIPT OF A NOTICE OF INTENT FOR CONSTRUCTION.
  - STABILIZATION SHALL BEGIN WITHIN 14 DAYS ON AREAS OF THE SITE WHERE CONSTRUCTION ACTIVITIES HAVE REMAININGLY CEASED OR HAVE BEEN SUSPENDED FOR MORE THAN 90 DAYS. WHEN SNOW COVER OR DELAYS IN STABILIZATION SHALL BEGIN AS SOON AS POSSIBLE. STABILIZATION PRACTICES SHALL BE MAINTAINED THROUGHOUT THE CONSTRUCTION PERIOD.
  - FOR ALL CRITICAL AREAS (WITHIN 25' OF A STREAM), SOIL STABILIZATION TECHNIQUES SHALL BE IMPLEMENTED WITHIN 24 HOURS OR AS SOON AS PRACTICAL AFTER THE AREAS HAVE BEEN EXPOSED FROM THE ROADWAY. STABILIZATION PRACTICES SHALL BE MAINTAINED THROUGHOUT THE CONSTRUCTION PERIOD.
  - A STORMWATER PREVENTION PLAN (SWPPP) SHALL BE DEVELOPED AND IMPLEMENTED AS OUTLINED IN THE KROSSLER STORMWATER PERMIT KTR 10.
  - INLET PROTECTION IS REQUIRED TO MINIMIZE DISCHARGE OF SEDIMENT, LAKE WATER, AND OTHER POLLUTANTS TO THE RECEIVING WATER BODY.
  - ALL SLOPES EXCEEDING 3:1 SHALL HAVE EXTRA SOLE PROTECTION SUCH AS NETTING.
  - SEDIMENT BASINS (DEBRIS BASINS, DESLTING BASINS, OR SEDIMENT TRAPS) SHALL BE INSTALLED DURING THE INITIAL GRADING AT LOCATIONS THAT WILL DISCHARGE INTO DRAINAGE CHANNELS OR SEWERS OR ONTO ADJACENT LAND.
  - ALL SLOPES EXCEEDING 3:1 SHALL HAVE EXTRA SOLE PROTECTION SUCH AS NETTING.
  - INLET PROTECTION IS REQUIRED TO MINIMIZE DISCHARGE OF SEDIMENT, LAKE WATER, AND OTHER POLLUTANTS TO THE RECEIVING WATER BODY.
  - STREETS, INTO DRAINAGE CHANNELS OR SEWERS OR ONTO ADJACENT LAND.
  - EROSION CONTROL MEASURES SHOWN ARE THE MINIMUM REQUIRED. CONTRACTOR SHALL PROVIDE ADDITIONAL CONTROL AND REVISE THE CONTROLS AS NECESSARY.
  - ALL DRAINAGE CONTROL MEASURES, DISCHARGE LOCATIONS, VEHICLE EXITS, DISTURBED AREAS OF THE SITE, AND MATERIALS STORAGE AREAS SHALL BE INSPECTED WEEKLY AND WITHIN 24 HOURS OF THE END OF A STORM THAT IS 0.2 INCHES OR GREATER. EACH INSPECTION MUST BE DOCUMENTED IN ACCORDANCE WITH THE KROSSLER STORMWATER PERMIT KTR 10.
  - SEDIMENT ACCUMULATED AT THE SILT FENCES, INLET PROTECTION AREAS, AND OTHER SILT CHECK DEVICES SHOULD BE REMOVED NO LATER THAN WHEN IT IS NEARLY FULL. SEDIMENT MUST BE REMOVED FROM ANY SEDIMENT BASINS WHEN THE NO MORE THAN 10 VOLUME HAS BEEN FILLED WITH COLLECTED SEDIMENT.
  - ALL REQUIRED REPAIRS ARE TO BE MADE IMMEDIATELY.
  - ALL REQUIRED REPAIRS ARE TO BE SPRIGGED AND VEGETATED OR OTHERWISE STABILIZED IN A MANNER THAT DOES NOT RESULT IN MUDDY RUNOFF TO NEARBY DITCHES AND WATER BODIES.
  - INSPECT THE CONSTRUCTION ENTRANCE DAILY TO ENSURE NO TRACKING OR PART ONTO LOCAL ROADWAYS. ALL SEDIMENT SPILLED, DROPPED, WASHED OR TRACKED OFF THE CONSTRUCTION SITE IS TO BE PICKED UP AND DISPOSED OF PROPERLY.
  - MAINTAIN THE ENTRANCE AS NECESSARY TO PREVENT TRACKING OF DIRT.

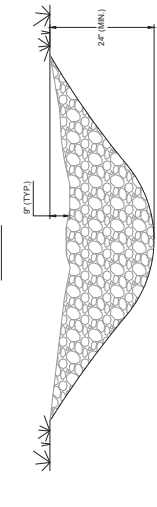

EROSION CONTROL NOTES

- EROSION CONTROL NOTES:**
- A KROSSLER STORMWATER PERMIT IS REQUIRED. COVERAGE STARTS WHEN THE KY DIVISION OF WATER ACKNOWLEDGES RECEIPT OF A NOTICE OF INTENT FOR CONSTRUCTION.
  - STABILIZATION SHALL BEGIN WITHIN 14 DAYS ON AREAS OF THE SITE WHERE CONSTRUCTION ACTIVITIES HAVE REMAININGLY CEASED OR HAVE BEEN SUSPENDED FOR MORE THAN 90 DAYS. WHEN SNOW COVER OR DELAYS IN STABILIZATION SHALL BEGIN AS SOON AS POSSIBLE. STABILIZATION PRACTICES SHALL BE MAINTAINED THROUGHOUT THE CONSTRUCTION PERIOD.
  - FOR ALL CRITICAL AREAS (WITHIN 25' OF A STREAM), SOIL STABILIZATION TECHNIQUES SHALL BE IMPLEMENTED WITHIN 24 HOURS OR AS SOON AS PRACTICAL AFTER THE AREAS HAVE BEEN EXPOSED FROM THE ROADWAY. STABILIZATION PRACTICES SHALL BE MAINTAINED THROUGHOUT THE CONSTRUCTION PERIOD.
  - A STORMWATER PREVENTION PLAN (SWPPP) SHALL BE DEVELOPED AND IMPLEMENTED AS OUTLINED IN THE KROSSLER STORMWATER PERMIT KTR 10.
  - INLET PROTECTION IS REQUIRED TO MINIMIZE DISCHARGE OF SEDIMENT, LAKE WATER, AND OTHER POLLUTANTS TO THE RECEIVING WATER BODY.
  - ALL SLOPES EXCEEDING 3:1 SHALL HAVE EXTRA SOLE PROTECTION SUCH AS NETTING.
  - SEDIMENT BASINS (DEBRIS BASINS, DESLTING BASINS, OR SEDIMENT TRAPS) SHALL BE INSTALLED DURING THE INITIAL GRADING AT LOCATIONS THAT WILL DISCHARGE INTO DRAINAGE CHANNELS OR SEWERS OR ONTO ADJACENT LAND.
  - ALL SLOPES EXCEEDING 3:1 SHALL HAVE EXTRA SOLE PROTECTION SUCH AS NETTING.
  - INLET PROTECTION IS REQUIRED TO MINIMIZE DISCHARGE OF SEDIMENT, LAKE WATER, AND OTHER POLLUTANTS TO THE RECEIVING WATER BODY.
  - STREETS, INTO DRAINAGE CHANNELS OR SEWERS OR ONTO ADJACENT LAND.
  - EROSION CONTROL MEASURES SHOWN ARE THE MINIMUM REQUIRED. CONTRACTOR SHALL PROVIDE ADDITIONAL CONTROL AND REVISE THE CONTROLS AS NECESSARY.
  - ALL DRAINAGE CONTROL MEASURES, DISCHARGE LOCATIONS, VEHICLE EXITS, DISTURBED AREAS OF THE SITE, AND MATERIALS STORAGE AREAS SHALL BE INSPECTED WEEKLY AND WITHIN 24 HOURS OF THE END OF A STORM THAT IS 0.2 INCHES OR GREATER. EACH INSPECTION MUST BE DOCUMENTED IN ACCORDANCE WITH THE KROSSLER STORMWATER PERMIT KTR 10.
  - SEDIMENT ACCUMULATED AT THE SILT FENCES, INLET PROTECTION AREAS, AND OTHER SILT CHECK DEVICES SHOULD BE REMOVED NO LATER THAN WHEN IT IS NEARLY FULL. SEDIMENT MUST BE REMOVED FROM ANY SEDIMENT BASINS WHEN THE NO MORE THAN 10 VOLUME HAS BEEN FILLED WITH COLLECTED SEDIMENT.
  - ALL REQUIRED REPAIRS ARE TO BE MADE IMMEDIATELY.
  - ALL REQUIRED REPAIRS ARE TO BE SPRIGGED AND VEGETATED OR OTHERWISE STABILIZED IN A MANNER THAT DOES NOT RESULT IN MUDDY RUNOFF TO NEARBY DITCHES AND WATER BODIES.
  - INSPECT THE CONSTRUCTION ENTRANCE DAILY TO ENSURE NO TRACKING OR PART ONTO LOCAL ROADWAYS. ALL SEDIMENT SPILLED, DROPPED, WASHED OR TRACKED OFF THE CONSTRUCTION SITE IS TO BE PICKED UP AND DISPOSED OF PROPERLY.
  - MAINTAIN THE ENTRANCE AS NECESSARY TO PREVENT TRACKING OF DIRT.

