

**COMMONWEALTH OF KENTUCKY
BEFORE THE PUBLIC SERVICE COMMISSION**

In the matter of:

THE APPLICATION OF EAST KENTUCKY NETWORK,)
LLC FOR THE ISSUANCE OF A CERTIFICATE OF)
PUBLIC CONVENIENCE AND NECESSITY TO) CASE NO. 2020-00397
CONSTRUCT A REPLACEMENT TOWER IN LAWRENCE)
COUNTY, KENTUCKY)

East Kentucky Network, LLC d/b/a Appalachian Wireless, was granted authorization to provide cellular service in the KY-9 Cellular Market Area (CMA451) by the Federal Communications Commission (FCC). FCC license is included as Exhibit 1. East Kentucky Network, LLC merger documents were filed with the Commission on February 2, 2001 in Case No. 2001-022. East Kentucky Network, LLC is a Kentucky Limited Liability Company that was organized on June 16, 1998. East Kentucky Network, LLC is in good standing with the state of Kentucky.

In an effort to improve service in Lawrence County, pursuant to KRS 278.020 Subsection 1 and 807 KAR 5:001, East Kentucky Network, LLC is seeking the Commission's approval to construct a 190 foot self supporting tower on a tract of land located at 2371 Fuller Ridge Road, Louisa, Lawrence County, Kentucky (38°09'32.46"N 82°39'53.24"W). A map and detailed directions to the site can be found in Exhibit 7.

Construction of the proposed tower is required by public convenience and necessity. Due to increasing demand for telecommunications service, the proposed tower is necessary to provide adequate coverage. The proposed tower will improve service in Lawrence County by providing an interconnection between East Kentucky Network, LLC's other sites thereby forming a cohesive network.

Exhibit 2 is a list of all Property owners according to the Property Valuation Administrator's record who own property within 500 feet of the proposed Tower and all property owners who own property contiguous to the property upon which construction is proposed in accordance with the Property Valuation Administrator's record.

Pursuant to 807 KAR 5:063 Section 1(1)(l), Section 1(m) and Section 2, all affected property owners according to the Property Valuation Administrator's record who own property within 500 feet of the proposed Tower or contiguous to the property upon which construction is proposed were notified by certified mail return receipt requested of East Kentucky Network, LLC's proposed construction and informed of their right to intervene. They were given the docket number under which this application is filed. Enclosed in Exhibit 2 is a copy of that notification.

Lawrence County has no formal local planning unit. In absence of this unit, the Lawrence County Judge Executive's office was notified by certified mail, return receipt requested, of East Kentucky Network, LLC's proposal and informed of their right to intervene. The Lawrence County Judge Executive's office was also given the docket number under which this application is filed. Enclosed in Exhibit 3 is a copy of that notification.

Notice of the location of the proposed construction was published in The Big Sandy News, December 16, 2020 edition. Enclosed is a copy of that notice in Exhibit 3. The Big Sandy News is the newspaper with the largest circulation in Lawrence County.

A geologist was employed to determine soil and rock types and to ascertain the distance to solid bedrock. The geotechnical report is enclosed as Exhibit 4.

A copy of the tower design information is enclosed as Exhibit 5. The proposed tower has been designed by engineers at Rohn Tower Company and will be constructed under their

supervision. Their qualifications are evidenced in Exhibit 5 by the seal and signature of the registered professional engineer responsible for this project.

The tower will be erected by S & S Tower Services of St. Albans, West Virginia. S & S Tower Services has vast experience in the erection of communications towers. Their qualifications are described in Exhibit 13.

FAA determination and Kentucky Airport Zoning Commission application are included as Exhibit 6.

No Federal Communications Commission approval is required prior to construction of this facility. Once service is established from this tower we must immediately notify the Federal Communications Commission of its operation. Prior approval is needed only if the proposed facility increases the size of the cellular geographic service area. This cell site will not expand the cellular geographic service area.

Two notice signs meeting the requirements prescribed by 807 KAR 5:063, Section 1(2), measuring at least two (2) feet in height and four (4) feet in width and containing all required language in letters of required height, have been posted, one at a visible location on the proposed site and one on the nearest public road. The two signs were posted on December 14, 2020, and will remain posted for at least two weeks after filing of this application as specified.

Enclosed in Exhibit 8 is a copy of East Kentucky Network, LLC's Assignment of Lease Agreements for the site location along with a lot description.

The proposed construction site is on a very rugged mountain top in close proximity to the existing tower. There is an existing 170' guyed tower owned by East Kentucky Network, LLC and will be removed upon construction of the proposed tower.

East Kentucky Network, LLC's operation will not affect the use of nearby land nor its value. No more suitable site exists in the area. A copy of the search area map is enclosed in Exhibit 7.

No other tower capable of supporting East Kentucky Network, LLC's load exists in the general area; therefore, there is no opportunity for co-location of our facilities with anyone else.

Enclosed, and filed as Exhibit 9 is a survey of the proposed tower site signed by a Kentucky registered professional engineer.

Exhibit 10 is a map in one (1) inch equals 200 feet scale identifying every structure and every owner of real estate within 500 feet of the proposed tower and all property owners who own contiguous property to the property upon which construction is proposed.

Exhibit 11 contains a vertical sketch of the tower supplied by David Rasnick, Kentucky registered professional engineer.

Enclosed as Exhibit 12 is a list of utilities, corporations, or persons with whom the tower is likely to compete.

[THE REMAINDER OF THIS PAGE INTENTIONALLY LEFT BLANK.]

WHEREFORE, Applicant, having met the requirements of KRS 278.020(1), 278.650, 278.665, and all applicable rules and regulations of the PSC, respectfully requests that the PSC accept the foregoing Application for filing and grant a Certificate of Public Convenience and Necessity to construct and operate the proposed tower.

The foregoing document was prepared by Krystal Branham, Regulatory Compliance Attorney for East Kentucky Network, LLC d/b/a Appalachian Wireless. All related questions or correspondence concerning this filing should be mailed to East Kentucky Network, LLC d/b/a Appalachian Wireless, 101 Technology Trail, Ivel, KY 41642.

SUBMITTED BY: Lynn Haney DATE: 12/14/2020
Lynn Haney, Regulatory Compliance Director

APPROVED BY: W.A. Gillum DATE: 12/16/2020
W.A. Gillum, General Manager

ATTORNEY: Krystal Branham DATE: 12/15/2020
Hon. Krystal Branham, Attorney

CONTACT INFORMATION:

W.A. Gillum, General Manager
Phone: (606) 477-2355, Ext. 111
Email: wagillum@ekn.com

Lynn Haney, Regulatory Compliance Director
Phone: (606) 477-2355, Ext. 1007
Email: lhaney@ekn.com

Krystal Branham, Attorney
Phone: (606) 477-2355, Ext. 1009
Email: kbranham@ekn.com

Mailing Address:

**East Kentucky Network, LLC
d/b/a Appalachian Wireless
101 Technology Trail
Ivel, KY 41642**

1	FCC License
2	Copies of Cell Site Notice to Land Owners
3	Notifications of County Judge Executive and Newspaper
4	Universal Soil Bearing Analysis
5	Tower Design
6	FAA Determination and KAZC Application
7	Driving Directions from County Court House and Map to Suitable Scale
8	Assignment of Lease Agreements
9	Survey of Site Signed/Sealed by Professional Engineer Registered in State of Kentucky
10	Site Survey Map with Property Owners Identified in Accordance with PVA of County
11	Vertical Profile Sketch of Proposed Tower
12	List of Competitors
13	Qualifications
14	
15	

Exhibit 1

ULS License

Cellular License - KNKN880 - East Kentucky Network, LLC d/b/a Appalachian Wireless

Call Sign	KNKN880	Radio Service	CL - Cellular
Status	Active	Auth Type	Regular

Market

Market	CMA451 - Kentucky 9 - Elliott	Channel Block	B
Submarket	0	Phase	2

Dates

Grant	08/30/2011	Expiration	10/01/2021
Effective	09/04/2014	Cancellation	

Five Year Buildout Date

10/23/1996

Control Points

1 U.S. 23, HAROLD, KY

Licensee

FRN	0001786607	Type	Limited Liability Company
-----	------------	------	---------------------------

Licensee

East Kentucky Network, LLC d/b/a Appalachian Wireless
 101 Technology Trail
 Ivel, KY 41642
 ATTN W.A. Gillum, General Manager / CEO
 P:(606)477-2355

Contact

Lukas, Nace, Gutierrez & Sachs, LLP	P:(703)584-8665
Pamela L Gist Esq	F:(703)584-8696
8300 Greensboro Drive	E:pgist@fcclaw.com
McLean, VA 22102	

Ownership and Qualifications

Radio Service Type	Mobile
Regulatory Status	Common Carrier Interconnected Yes

Alien Ownership

The Applicant answered "No" to each of the Alien Ownership questions.

Basic Qualifications

The Applicant answered "No" to each of the Basic Qualification questions.

Demographics

Race

Ethnicity

Gender

Exhibit 2

EXHIBIT 2 – LIST OF PROPERTY OWNERS

Statement Pursuant to Section 1 (1) (I) 807 KAR 5:063

Section 1 (1)(I) 1. The following is a list of every property owner who according to property valuation administrator's records, owns property within 500 feet of the proposed tower and each have been: notified by certified mail, return receipt requested, of the proposed construction,

Section 1 (1)(I) 2. Every person listed below who, according to the property valuation administrator's records, owns property within 500 feet of the proposed tower has been: Given the Commission docket number under which the application will be processed: and

Section 1 (1)(I) 3. Every person listed below who, according to property valuation administrator's records owns property within 500 feet of the proposed tower has been: Informed of his right to request intervention.

Section 2. If the construction is proposed for an area outside the incorporated boundaries of a city, the application shall state that public notices required by Section 1(1)(L) have been sent to every person who, according to the property valuation administrator, owns property contiguous to the property upon which the construction is proposed

LIST OF PROPERTY OWNERS

Paul Rice
2615 Fuller Ridge Road
Louisa, KY 41230

William and Barbara Harris
388 Mink Lane
Louisa, KY 41230

Arthur and Angela Crigger
58 Beech Street
Kermit, WV 25674

Tracey Ann Jordan
9546 Faulkner Sqaure
Brentwood, TN 37027

Glenda Tackett
139 Bobcat Ridge Road
Louisa , KY 41230

David and Lisa Roberts
2263 Fuller Ridge Road
Louisa, KY 41230

Big Sandy Water District
Fuller Branch Tank Site Easement
18200 State Rt 3
Cattletsburg, KY 41129

VIA: U.S. CERTIFIED MAIL

PUBLIC NOTICE

December 17, 2020

Paul Rice
2615 Fuller Ridge Road
Louisa, KY 41230

RE: Public Notice-Public Service Commission of Kentucky (Case No. 2020-00397)

East Kentucky Network, LLC d/b/a Appalachian Wireless has applied to the Public Service Commission of Kentucky for a Certificate of Public Convenience and Necessity to construct and operate a new facility to provide cellular telecommunications service in Lawrence County. The facility will include a 190'-foot self-supporting tower with attached antennas extending upwards, and an equipment shelter located on a tract of land at 2371 Fuller Ridge Road, Louisa. A map showing the location of the proposed new facility is enclosed. This notice is being sent to you because you may own property within a 500' radius of the proposed tower or own property contiguous to the property upon which construction is proposed.

The Commission invites your comments regarding the proposed construction. You also have the right to intervene in this matter. The Commission must receive your initial communication within 20 days of the date of this letter as shown above.

Your comments and request for intervention should be addressed to: Executive Director's Office, Public Service Commission of Kentucky, P.O. Box 615, Frankfort, KY 40602. Please refer to Case No. 2020-00397 in your correspondence.

If you have any questions for East Kentucky Network, LLC, please direct them to my attention at the following address: East Kentucky Network, LLC, 101 Technology Trail, Ivel, KY 41642 or call me at 606-477-2355, Ext. 1007.

Sincerely,



Lynn Haney, CPA
Regulatory Compliance Director
Enclosure 1



VIA: U.S. CERTIFIED MAIL

PUBLIC NOTICE

December 17, 2020

William and Barbara Harris
388 Mink Lane
Louisa, KY 41230

RE: Public Notice-Public Service Commission of Kentucky (Case No. 2020-00397)

East Kentucky Network, LLC d/b/a Appalachian Wireless has applied to the Public Service Commission of Kentucky for a Certificate of Public Convenience and Necessity to construct and operate a new facility to provide cellular telecommunications service in Lawrence County. The facility will include a 190'-foot self-supporting tower with attached antennas extending upwards, and an equipment shelter located on a tract of land at 2371 Fuller Ridge Road, Louisa. A map showing the location of the proposed new facility is enclosed. This notice is being sent to you because you may own property within a 500' radius of the proposed tower or own property contiguous to the property upon which construction is proposed.

The Commission invites your comments regarding the proposed construction. You also have the right to intervene in this matter. The Commission must receive your initial communication within 20 days of the date of this letter as shown above.

Your comments and request for intervention should be addressed to: Executive Director's Office, Public Service Commission of Kentucky, P.O. Box 615, Frankfort, KY 40602. Please refer to Case No. 2020-00397 in your correspondence.

If you have any questions for East Kentucky Network, LLC, please direct them to my attention at the following address: East Kentucky Network, LLC, 101 Technology Trail, Ivel, KY 41642 or call me at 606-477-2355, Ext. 1007.

Sincerely,

Lynn Haney, CPA
Regulatory Compliance Director
Enclosure 1



VIA: U.S. CERTIFIED MAIL

PUBLIC NOTICE

December 17, 2020

Arthur and Angela Crigger
58 Beech Street
Kermit, WV 25674

RE: Public Notice-Public Service Commission of Kentucky (Case No. 2020-00397)

East Kentucky Network, LLC d/b/a Appalachian Wireless has applied to the Public Service Commission of Kentucky for a Certificate of Public Convenience and Necessity to construct and operate a new facility to provide cellular telecommunications service in Lawrence County. The facility will include a 190'-foot self-supporting tower with attached antennas extending upwards, and an equipment shelter located on a tract of land at 2371 Fuller Ridge Road, Louisa. A map showing the location of the proposed new facility is enclosed. This notice is being sent to you because you may own property within a 500' radius of the proposed tower or own property contiguous to the property upon which construction is proposed.

The Commission invites your comments regarding the proposed construction. You also have the right to intervene in this matter. The Commission must receive your initial communication within 20 days of the date of this letter as shown above.

Your comments and request for intervention should be addressed to: Executive Director's Office, Public Service Commission of Kentucky, P.O. Box 615, Frankfort, KY 40602. Please refer to Case No. 2020-00397 in your correspondence.

If you have any questions for East Kentucky Network, LLC, please direct them to my attention at the following address: East Kentucky Network, LLC, 101 Technology Trail, Ivel, KY 41642 or call me at 606-477-2355, Ext. 1007.

Sincerely,

A handwritten signature in blue ink that reads "Lynn Haney".

Lynn Haney, CPA
Regulatory Compliance Director
Enclosure 1



VIA: U.S. CERTIFIED MAIL

PUBLIC NOTICE

December 17, 2020

Tracey Ann Jordan
9546 Faulkner Sqaure
Brentwood, TN 37027

RE: Public Notice-Public Service Commission of Kentucky (Case No. 2020-00397)

East Kentucky Network, LLC d/b/a Appalachian Wireless has applied to the Public Service Commission of Kentucky for a Certificate of Public Convenience and Necessity to construct and operate a new facility to provide cellular telecommunications service in Lawrence County. The facility will include a 190'-foot self-supporting tower with attached antennas extending upwards, and an equipment shelter located on a tract of land at 2371 Fuller Ridge Road, Louisa. A map showing the location of the proposed new facility is enclosed. This notice is being sent to you because you may own property within a 500' radius of the proposed tower or own property contiguous to the property upon which construction is proposed.

The Commission invites your comments regarding the proposed construction. You also have the right to intervene in this matter. The Commission must receive your initial communication within 20 days of the date of this letter as shown above.

Your comments and request for intervention should be addressed to: Executive Director's Office, Public Service Commission of Kentucky, P.O. Box 615, Frankfort, KY 40602. Please refer to Case No. 2020-00397 in your correspondence.

If you have any questions for East Kentucky Network, LLC, please direct them to my attention at the following address: East Kentucky Network, LLC, 101 Technology Trail, Ivel, KY 41642 or call me at 606-477-2355, Ext. 1007.

Sincerely,

A handwritten signature in blue ink that reads "Lynn Haney".

Lynn Haney, CPA
Regulatory Compliance Director
Enclosure 1

VIA: U.S. CERTIFIED MAIL

PUBLIC NOTICE

December 17, 2020

Glenda Tackett
139 Bobcat Ridge Road
Louisa, KY 41230

RE: Public Notice-Public Service Commission of Kentucky (Case No. 2020-00397)

East Kentucky Network, LLC d/b/a Appalachian Wireless has applied to the Public Service Commission of Kentucky for a Certificate of Public Convenience and Necessity to construct and operate a new facility to provide cellular telecommunications service in Lawrence County. The facility will include a 190'-foot self-supporting tower with attached antennas extending upwards, and an equipment shelter located on a tract of land at 2371 Fuller Ridge Road, Louisa. A map showing the location of the proposed new facility is enclosed. This notice is being sent to you because you may own property within a 500' radius of the proposed tower or own property contiguous to the property upon which construction is proposed.

The Commission invites your comments regarding the proposed construction. You also have the right to intervene in this matter. The Commission must receive your initial communication within 20 days of the date of this letter as shown above.

Your comments and request for intervention should be addressed to: Executive Director's Office, Public Service Commission of Kentucky, P.O. Box 615, Frankfort, KY 40602. Please refer to Case No. 2020-00397 in your correspondence.

If you have any questions for East Kentucky Network, LLC, please direct them to my attention at the following address: East Kentucky Network, LLC, 101 Technology Trail, Ivel, KY 41642 or call me at 606-477-2355, Ext. 1007.

Sincerely,



Lynn Haney, CPA
Regulatory Compliance Director
Enclosure 1



VIA: U.S. CERTIFIED MAIL

PUBLIC NOTICE

December 17, 2020

David and Lisa Roberts
2263 Fuller Ridge Road
Louisa, KY 41230

RE: Public Notice-Public Service Commission of Kentucky (Case No. 2020-00397)

East Kentucky Network, LLC d/b/a Appalachian Wireless has applied to the Public Service Commission of Kentucky for a Certificate of Public Convenience and Necessity to construct and operate a new facility to provide cellular telecommunications service in Lawrence County. The facility will include a 190'-foot self-supporting tower with attached antennas extending upwards, and an equipment shelter located on a tract of land at 2371 Fuller Ridge Road, Louisa. A map showing the location of the proposed new facility is enclosed. This notice is being sent to you because you may own property within a 500' radius of the proposed tower or own property contiguous to the property upon which construction is proposed.

The Commission invites your comments regarding the proposed construction. You also have the right to intervene in this matter. The Commission must receive your initial communication within 20 days of the date of this letter as shown above.

Your comments and request for intervention should be addressed to: Executive Director's Office, Public Service Commission of Kentucky, P.O. Box 615, Frankfort, KY 40602. Please refer to Case No. 2020-00397 in your correspondence.

If you have any questions for East Kentucky Network, LLC, please direct them to my attention at the following address: East Kentucky Network, LLC, 101 Technology Trail, Ivel, KY 41642 or call me at 606-477-2355, Ext. 1007.

Sincerely,

A handwritten signature in blue ink that reads "Lynn Haney".

Lynn Haney, CPA
Regulatory Compliance Director
Enclosure 1



VIA: U.S. CERTIFIED MAIL

PUBLIC NOTICE

December 17, 2020

Big Sandy Water District
Fuller Branch Tank Site Easement
18200 State Rt 3
Cattlettsburg, KY 41129

RE: Public Notice-Public Service Commission of Kentucky (Case No. 2020-00397)

East Kentucky Network, LLC d/b/a Appalachian Wireless has applied to the Public Service Commission of Kentucky for a Certificate of Public Convenience and Necessity to construct and operate a new facility to provide cellular telecommunications service in Lawrence County. The facility will include a 190'-foot self-supporting tower with attached antennas extending upwards, and an equipment shelter located on a tract of land at 2371 Fuller Ridge Road, Louisa. A map showing the location of the proposed new facility is enclosed. This notice is being sent to you because you may own property within a 500' radius of the proposed tower or own property contiguous to the property upon which construction is proposed.

The Commission invites your comments regarding the proposed construction. You also have the right to intervene in this matter. The Commission must receive your initial communication within 20 days of the date of this letter as shown above.

Your comments and request for intervention should be addressed to: Executive Director's Office, Public Service Commission of Kentucky, P.O. Box 615, Frankfort, KY 40602. Please refer to Case No. 2020-00397 in your correspondence.

If you have any questions for East Kentucky Network, LLC, please direct them to my attention at the following address: East Kentucky Network, LLC, 101 Technology Trail, Ivel, KY 41642 or call me at 606-477-2355, Ext. 1007.

Sincerely,


Lynn Haney, CPA
Regulatory Compliance Director
Enclosure 1

Fallsburg Replacement

Location:
2371 Fuller Ridge Road
Louisa, KY 41230

Coordinates:
38° 09' 32.46" N
82° 39' 53.24" W

Legend

 1/2 Mile Radius

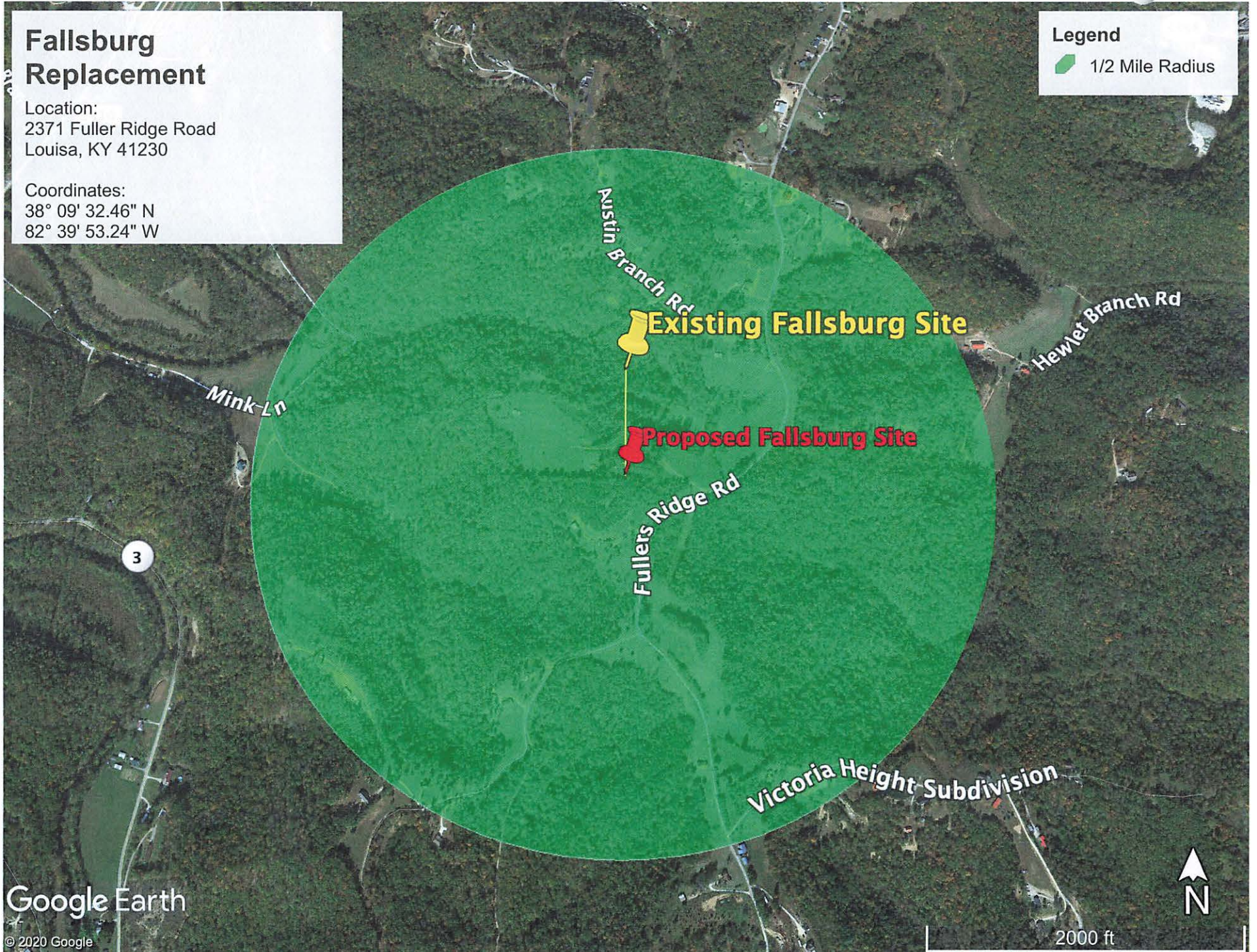


Exhibit 3

VIA: U.S. CERTIFIED MAIL

December 17, 2020

Phillip L. Carter, Judge Executive
122 Main Cross Street
Louisa, KY 41230

RE: Public Notice-Public Service Commission of Kentucky (Case No. 2020-00397)

East Kentucky Network, LLC d/b/a Appalachian Wireless has applied to the Public Service Commission of Kentucky for a Certificate of Public Convenience and Necessity to construct and operate a new facility to provide cellular telecommunications service in Lawrence County. The facility will include a 190-foot self-supporting tower with attached antennas extending upwards, and an equipment shelter located on a tract of land at 2371 Fullers Ridge Road, Louisa, Lawrence County, Kentucky. A map showing the location of the proposed new facility is enclosed. This notice is being sent to you because you are the County Judge Executive of Lawrence County.

The Commission invites your comments regarding the proposed construction. You also have the right to intervene in this matter. The Commission must receive your initial communication within 20 days of the date of this letter as shown above.

Your comments and request for intervention should be addressed to: Executive Director's Office, Public Service Commission of Kentucky, P.O. Box 615, Frankfort, KY 40602. Please refer to Case No. 2020-00397 in your correspondence.

If you have any questions for East Kentucky Network, LLC, please direct them to my attention at the following address: East Kentucky Network, LLC, 101 Technology Trail, Ivel, KY 41642 or call me at 606-477-2355, Ext. 1007.

Sincerely,

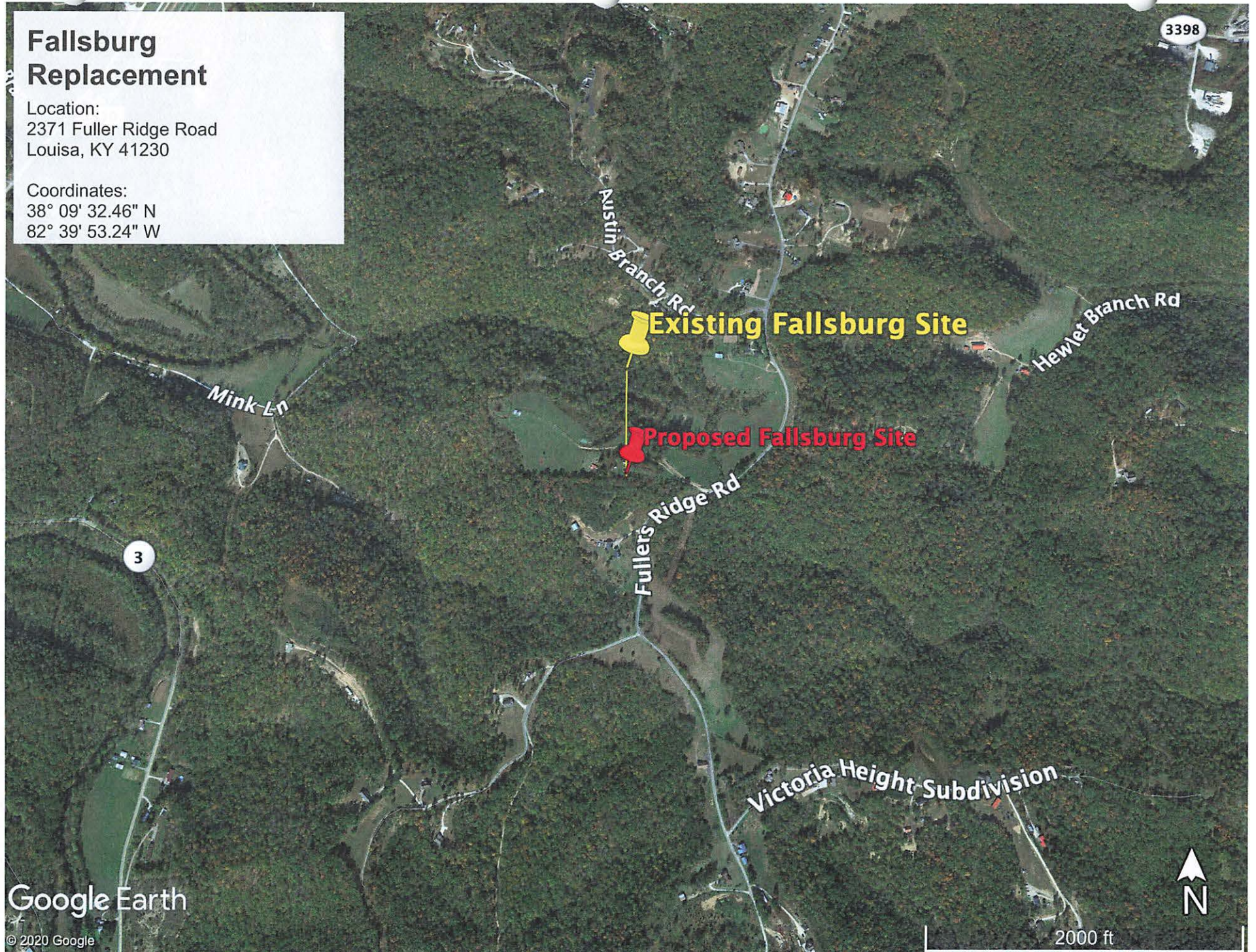


Lynn Haney, CPA
Regulatory Compliance Director
Enclosure

Fallsburg Replacement

Location:
2371 Fuller Ridge Road
Louisa, KY 41230

Coordinates:
38° 09' 32.46" N
82° 39' 53.24" W



Google Earth

© 2020 Google

2000 ft

dba Appalachian Wireless
101 Technology Trail
Ivel, KY 41642
Phone: 606-477-2355
Fax: 606-791-2225

EAST KENTUCKY
NETWORK



To: The Big Sandy News
Attn: Classifieds

From: Raina Helton
Regulatory Compliance Assistant

Email: brenda@thebigsandynews.com **Date:** December 11, 2020

Re: PUBLIC NOTICE ADVERTISEMENT **Pages:** 1

Please place the following Public Notice Advertisement in The Big Sandy Times to be ran on December 16, 2020

PUBLIC NOTICE:

RE: Public Service Commission of Kentucky (CASE NO. 2020-00397)

Public Notice is hereby given that East Kentucky Network, LLC, dba Appalachian Wireless has applied to the Kentucky Public Service Commission to construct a replacement cellular telecommunications tower on a tract of land located at 2371 Fuller Ridge Road, Louisa, Lawrence County, Kentucky. The proposed tower will be a 190 foot self-supporting tower with attached antennas. If you would like to respond to this notice, please contact the Executive Director, Public Service Commission, 211 Sower Boulevard, PO Box 615, Frankfort, Kentucky 40602. Please refer to Case No. 2020-00397.

If you have any questions about the placement of the above mentioned notice, please call me at 606-477-2375, ext. 1005.

Thank you,

Raina Helton
Regulatory Compliance Paralegal

The message above and the information contained in the documents transmitted are confidential and intended only for the person(s) named above. Dissemination, distribution or copying of this communication by anyone other than the person(s) named above is prohibited. If you have received this communication in error, please notify us immediately by telephone and return the original message to us at the address listed above via regular mail. Thank you.

Exhibit 4



230 Swartz Drive • Hazard • Kentucky • 41701
Phone (606) 551-1050

EAST KENTUCKY ENGINEERING, LLC.

**APPALACHIAN WIRELESS
Geotechnical Investigation on the
Fullers Ridge Tower Site
Lawrence County, Kentucky
EKYENG Project No. 165-000-0118**

PREPARED FOR:

Appalachian Wireless.
101 Technology Trail
Ivel, Kentucky 41642

PREPARED BY:

Richard Dirk Smith PE, PLS
President
East Kentucky Engineering
230 Swartz Drive
Hazard, Kentucky 41701

_____, 20215, November 16th, 2020



EAST KENTUCKY ENGINEERING, LLC.

EXECUTIVE SUMMARY

1.0 INTRODUCTION

2.0 PROJECT DESCRIPTION

3.0 SITE DESCRIPTION & HISTORICAL MINING

3.1 GENERAL INFORMATION

3.2 SURFACE MINING

3.3 UNDERGROUND MINING

3.4 FLOOD HAZARD

4.0 FIELD EXPLORATION

4.1 SITE INFORMATION

4.2 TRENCHING

4.3 GROUNDWATER

4.4 SEISMIC SITE CLASSIFICATION

5.0 DISCUSSION AND RECOMMENDATIONS

5.1 GENERAL

5.2 SHALLOW MAT FOUNDATIONS RECOMMENDATIONS

5.3 BURIED UTILITIES

6.0 WARRANTY

6.1 SUBSURFACE EXPLORATION

6.2 LABORATORY AND FIELD TEST

6.3 ANALYSIS AND RECOMMENDATIONS

6.4 CONSTRUCTION MONITORING

6.5 GENERAL

SPECIFICATIONS

I – GENERAL

II – ENGINEERED FILL BENEATH STRUCTURES CLEARING AND GRADING SPECIFICATIONS

III – GUIDELINES FOR EXCAVATIONS AND TRENCHING

IV – GENERAL CONCRETE SPECIFICATIONS

APPENDIX A – PHOTOGRAPHS

APPENDIX B – BORING LOGS

APPENDIX C – SEISMIC DATA

APPENDIX D – MAPS



EAST KENTUCKY ENGINEERING, LLC.

EXECUTIVE SUMMARY

A geotechnical investigation has been performed on the Fullers Ridge Tower Site, located in Lawrence County, Kentucky. This site is readily accessible. A location map is shown in Figure 1 of this report. Field inspections were completed by trenching with an excavator. The following geotechnical considerations were identified:

- Trenching utilized for this study encountered soils and sandstone.
- Elevations were taken from aerial DEM mapping available at ArcGIS Kentucky Elevation Data, and Static GPS Surveying.
- The maximum estimated base elevation of the tower mat foundation is 1006.0 ft.
- This site is on a knob adjacent to an existing tower.
- **The allowable bearing capacities are estimated at 8 TSF for the sandstone rock foundations, with a tower pad elevation of 1012.0 ft.**
- The 2018 Kentucky Building Code seismic site classification for this site is "A."
- If during the foundation design it becomes necessary to lower or raise the footer, alternate design recommendations can be provided by EKYENG.
- Close monitoring of the construction operations discussed herein will be critical in achieving the design subgrade support. We, therefore, recommend that EKYENG is retained to monitor this portion of the work.

This executive summary is included to provide a general overview of the project and should not be relied upon except for the purpose it was prepared. Please rely on the complete report for the information on the findings, recommendations, and all other concerns.



EAST KENTUCKY ENGINEERING, LLC.

1. INTRODUCTION

East Kentucky Engineering (EKYENG) was retained by Mr. Stanton Neece of Appalachian Wireless to prepare a geotechnical engineering report for the proposed tower site located on the Fullers Ridge Property, in Lawrence County, Kentucky. A site location map is shown in Figure No. 1.

Pits were opened by trenching. The purpose of these services is to provide information and geotechnical engineering recommendations about subsurface conditions, earthwork, seismic considerations, groundwater conditions, and foundation design.

2.0 PROJECT DESCRIPTION

The proposed communication facility will consist of a self-supporting tower of undetermined height and ancillary support areas. The footing area is estimated to be 28 ft. X 28 ft. with an estimated base of the tower footer elevation at 1006.0 ft. Based on the information provided, we estimate the structural loads will be like the following conditions.

CONDITION	LOAD
Total Shear	40 Kips
Axial Load	50 Kips

We anticipate that overturning will govern the structural design. If the loading is significantly different than these expected values, EKYENG should be notified to re-evaluate the recommendations provided in this report.



EAST KENTUCKY ENGINEERING, LLC.

3.0 SITE DESCRIPTION & HISTORICAL MINING

3.1 GENERAL INFORMATION

The site location is on a knob, adjacent to an existing tower in Lawrence County, Kentucky. The current surface elevation is approximately 1,008 ft. Research on the historical mining was conducted by obtaining previous mine license maps from the "Kentucky Mine Mapping Information System" (KMMIS).

3.2 SURFACE MINING

No surface mining or auger mining was found during our research that would influence this site. No adverse issues from surface mining activities are expected at this site location.

3.3 UNDERGROUND MINING

No underground mines were found within the vicinity of this site. Therefore, no subsidence issues are anticipated.

3.4 FLOOD HAZARD

A flood determination was conducted by EKYENG. For this determination, the FEMA Flood Map Service was reviewed for this location. The flood map for the selected area is number **21127C0120D-210258**. The flood zone for this area is Zone X and is an area of minimal flood Hazard. A FIRMette map is included in Appendix C of this report.

4.0 FIELD EXPLORATION

4.1 SITE INFORMATION

The proposed site is located on a knob in Lawrence County, Kentucky. The site lies within the Fallsburg Quadrangle. The site is not readily accessible by conventional exploratory equipment. An estimated pad location was determined



EAST KENTUCKY ENGINEERING, LLC.

based on the information provided. Foundation dimensions were estimated to be a 28 ft X 28 ft footer for this report.

4.2 TRENCHING

This investigation was conducted by trenching with an excavator to determine subsurface information. The combinations of trenching and visual inspections were used to evaluate the site lithology and type of materials immediately below the proposed tower site. The following soils and rock properties were found.

TABLE 2

Test Pit	DEPTH INCREMENT, (FT.) TO REFUSAL	SOILS TYPE
TR	0.0 / 4.0	Soils / Clays
TR	4.0 / 12.0	Sandstone

Note: A cross-section of this information is in Appendix D of this report

4.3 GROUNDWATER

Groundwater in Eastern Kentucky is characterized by water flowing through a system of internal fractures that lead to an alluvial aquifer near the bottom of valley floors. Large, defined aquifers other than the alluvium is not common, especially in higher elevations such as where this tower site is proposed. Therefore, groundwater should not be a concern in this area. During field test activities, no groundwater resources were observed.

4.4 SEISMIC SITE CLASSIFICATION



EAST KENTUCKY ENGINEERING, LLC.

Based on the encountered soil conditions at the project site, the site classification was determined to be "Site Class A" per the 2018 Kentucky Building Code. In addition, an S_{D5} coefficient of 0.086 g was calculated, and an S_{D1} coefficient of 0.041 g was also calculated for design based on the aforementioned building code.

5.0 DISCUSSION AND RECOMMENDATIONS

5.1 GENERAL

The structure will be a self-supporting free-standing tri-pole tower with a mat foundation. Due to wind loading, lattice tower foundations can experience both vertical loads and horizontal loads. The vertical loads act in both an upward and downward direction as the tower attempts to overturn and can act in any directions.

5.2 SHALLOW MAT FOUNDATIONS RECOMMENDATIONS

We are recommending shallow foundations. It should be noted that the material type and bearing capacity can vary significantly due to the inconsistency of the underlying material. Based on the laboratory and field testing, visual inspection of the materials, and practical experience we have estimated that the **allowable bearing capacity of the weathered interbedded sandstone at this site will be 8 TSF at the estimated mat base elevation of 1006.0 ft.** The sandstone unit is present from the range of 1005.0 ft to 1000.0 ft and will provide the necessary cut width to support the proposed mat without overhanging outside the rock outcrop line.

It is furthermore recommended that the slabs-on-grade be supported on a 4 to 6-inch layer of relatively clean granular material such as sand and gravel or crushed stone. This is to help distribute concentrated loads and equalize moisture conditions beneath the slab. Proper drainage must be incorporated into this granular layer to preclude future wet areas in the finished slab-on-grade.



EAST KENTUCKY ENGINEERING, LLC.

However, all topsoil and/or other deleterious materials encountered during site preparation must be removed and replaced with 4000 psi concrete below the foundation base. Provided that a minimum of 4 inches of granular material is placed below the new slab-on-grade, a modulus of subgrade reaction (k_{30}) of 100 lbs/cu in can be used for the design of the slabs.

The support structure for this tower can be placed as needed. It is recommended that test pits are examined to ensure that any of these structures are on the competent materials. If pockets of soft, loose, or otherwise unsuitable material are encountered in the footing excavations, and it is inconvenient to lower the footings, the proposed footing elevations may be re-established by backfilling after the undesirable material has been removed. The undercut excavation beneath each footing should extend to suitable bearing soils, and the dimensions of the excavation base should be determined by imaginary planes extending outward and down on a 1 (vertical) to 1 (horizontal) slope from the base perimeter of the footing. The entire excavation should then be refilled with a well-compacted engineered fill, or lean concrete (Please note that the width of the lean concrete zone should be equal or wider than the width of the overlying footing element). Special care should be exercised to remove any sloughed, loose or soft materials near the base of the excavation slopes. In addition, special care should be taken to "tie-in" the compacted fill with the excavation slopes, with benches as necessary, to ensure that no pockets of loose or soft materials will be left in place along the excavation slopes below the foundation bearing level. All Federal, State, and Local regulations should be strictly adhered to relative to excavation side-slope geometry.

5.3 BURIED UTILITIES

Excavations for buried utility pipelines should follow the guidelines outlined in this report. Depending on the pipeline material, a minimum thickness of at least 0.5 feet of select fine-grained granular bedding material should be used beneath all below-grade pipes, with a minimum cover thickness of at least 3 feet to afford an



EAST KENTUCKY ENGINEERING, LLC.

"arching" effect and reduce stresses on the pipe. The cover thickness may be reduced if the external loading condition on the pipe is relatively light or if the pipe is designed to withstand the external loading condition. It is not recommended that "pea-gravel", or other "open-work" aggregates be used for trench backfill since these materials are nearly impossible to compact and tend to pond water within their interstices.

6.0 WARRANTY

Our professional services have been performed, our findings obtained, and our recommendations prepared in accordance with generally accepted geotechnical engineering principles and practices. No other warranty, express or implied, is made.

While the services of EKYENG are a valuable and integral part of the design and construction teams, we do not warrant, guarantee, or ensure the quality or completeness of services provided by other members of those teams, the quality, completeness, or satisfactory performance of construction plans and specifications which we have not prepared, nor the ultimate performance of building site materials.

6.1 SUBSURFACE EXPLORATION

Subsurface exploration is normally accomplished by test borings, although test pits are sometimes employed. The location and elevation of the test locations should be considered accurate only to the degree inherent with the method used.

The boring log includes sampling information, description of the materials recovered, approximate depth of boundaries between soil and rock strata, and groundwater data. The boring log represents conditions specifically at the location and time the testing was conducted. The boundaries between different soil strata are indicated at specific depths; however, these depths are in fact



EAST KENTUCKY ENGINEERING, LLC.

approximate and are somewhat dependent upon the frequency of sampling (The transition between soil strata is often gradual). Free groundwater level readings are made at the times and under conditions stated on the boring logs (Groundwater levels change with time and season). The trenches and pits do not always remain open sufficiently long enough for the measured water level to coincide with the groundwater table.

6.2 LABORATORY AND FIELD TESTS

Laboratory and field tests are performed by specific ASTM standards unless otherwise indicated. All determinations included in each ASTM standard are not always required and performed. Each test report indicates the measurements and determinations made.

6.3 ANALYSIS AND RECOMMENDATIONS

The geotechnical report is prepared primarily to aid in the engineering design of site work and structural foundations. Although the information in the report is expected to be sufficient for these purposes, it is not intended to determine the cost of construction or to stand alone as a construction specification.

Our engineering report recommendations are based primarily on data from test borings or other methods made at the locations shown on the attached drawings. Soil variations may exist between test sites, and these variations may not become evident until construction. If significant variations are then noted, the geotechnical engineer should be contacted so that field conditions can be examined and recommendations revised if necessary.

The geotechnical engineering report states our understanding as to the location, dimensions and structural features proposed for the site. Any significant changes in the nature, design, or location of the site improvements **MUST** be communicated to the geotechnical engineer such that the geotechnical analysis, conclusions, and recommendations can be appropriately adjusted. The



EAST KENTUCKY ENGINEERING, LLC.

geotechnical engineer should be given the opportunity to review all drawings that have been prepared based on their recommendations.

6.4 CONSTRUCTION MONITORING

Construction monitoring is a vital element of complete geotechnical services. The field engineer/inspector is the owner's "representative" observing the work of the contractor, performing tests as required in the specifications, and reporting data developed from such tests and observations. The field engineer or inspector does not direct the contractor's construction means, methods, operations or personnel. The field inspector/engineer does not interfere with the relationship between the owner and the contractor and, except as an observer, does not become a substitute owner on site. The field inspector/engineer is responsible for his own safety but has no responsibility for the safety of other personnel at the site. The field inspector/engineer is an important member of a team whose responsibility is to watch and test the work being done and report to the owner whether that work is being carried out in general conformance with the plans and specifications.

6.5 GENERAL

The scope of our services did not include an environmental assessment for the presence or absence of hazardous or toxic materials in the soil, surface water, groundwater or air, on, within or beyond the site studied. Any statements in the report or on the boring logs regarding odors, staining of soils or other unusual items or conditions observed are strictly for the information of our client.

To evaluate the site for possible environmental liabilities, we recommend an environmental assessment, consisting of a detailed site reconnaissance, a record review, and report of findings. Additional subsurface drilling and samplings, including groundwater sampling, may be required.



EAST KENTUCKY ENGINEERING, LLC.

This report has been prepared for the exclusive use of Appalachian Wireless, for specific application to the proposed cellular tower located on the Fullers Ridge Property located in Lawrence County, Kentucky. Specific design and construction recommendations have been provided in the various sections of the report. The report shall, therefore, be used in its entirety. This report is not a bidding document and shall not be used for that purpose. Anyone reviewing this report must interpret and draw their conclusions regarding the specific construction techniques and methods that were chosen. EKYENG is not responsible for the independent conclusions, opinions or recommendations made by others based on the field exploratory and laboratory test data presented in this report.



EAST KENTUCKY ENGINEERING, LLC.

SPECIFICATIONS

I – GENERAL

1.0 STANDARDS AND DEFINITIONS

1.1 **STANDARDS** - All standards refer to latest edition unless otherwise noted.

1.1.1 ASTM D-698-70 (Method C) "Standard Test Methods for Moisture. Density Relations of Soils and Soil-Aggregate Mixtures Using 5.5-lb (2.5 kg.) Rammer and 12-inch (305-mm) Drop".

1.1.2 ASTM D-2922 "Standard Test Method for Density of Soil and Soil-Aggregate in Place by Nuclear Methods (Shallow Depth)."

1.1.3 ASTM D-1556 "Standard Test Method for Density of Soil in place by the Sand-Cone Method."

1.2 DEFINITIONS

1.2.1 Owner - In these specifications, the word "Owner" shall mean Appalachian Wireless.

1.2.2 Engineer - In these specifications, the word "Engineer" shall mean the Owner designated engineer.

1.2.3 Design Engineer - In these specifications, the words "Design Engineer" shall mean the Owner designated design engineer.

1.2.4 Contractor - In these specifications, the word "Contractor" shall mean the firm or corporation undertaking the execution of any work under the terms of these specifications.

1.2.5 Approved - In these specifications the word "approved" shall refer to the approval of the Engineer or his designated representative.

1.2.6 As Directed - In these specifications the words "as directed" shall refer to the directions to the Contractor from the Owner or his designated representative.



2.0 GENERAL CONDITIONS

- 2.1 The Contractor shall furnish all labor, material, and equipment and perform all work and services except those set-out and furnished by the Owner, necessary to complete in a satisfactory manner the site preparation, excavation, filling, compaction, grading as shown on the plans and as described therein.

This work shall consist of all mobilization clearing and grading, grubbing, stripping, removal of existing material unless otherwise stated, preparation of the land to be filled, filling of the land, spreading and compaction of the fill, and all subsidiary work necessary to complete the grading of the cut and fill areas to conform with the lines, grades, slopes, and specifications.

This work is to be accomplished under the observation of the Owner or his designated representative.

- 2.2 Prior to bidding the work, the Contractor shall examine, investigate and inspect the construction site as to the nature and location of the work, and the general and local conditions at the construction site, including, without limitation, the character of surface or subsurface conditions and obstacles to be encountered on and around the construction site; and shall make such additional investigation as he may deem necessary for the planning and proper execution of the work.

If conditions other than those indicated are discovered by the Contractor, the Owner should be notified immediately. The material which the Contractor believes to be a changed condition should not be disturbed so that the owner can investigate the condition.

- 2.3 The construction shall be performed under the direction of an experienced engineer who is familiar with the design plan.



EAST KENTUCKY ENGINEERING, LLC.

II - ENGINEERED FILL BENEATH STRUCTURES CLEARING AND GRADING SPECIFICATIONS

1.0 GENERAL CONDITIONS

The Contractor shall furnish all labor, materials, and equipment, and perform all work and services necessary to complete in a satisfactory manner the site preparation, excavation, filling, compaction and grading as shown on the plans and as described therein.

This work shall consist of all clearing and grading, removal of existing structures unless otherwise stated, preparation of the land to be filled, filling of the land, spreading and compaction of the fill, and all subsidiary work necessary to complete the grading of the cut and fill areas to conform with the lines, grades, slopes, and specifications.

This work is to be accomplished under the constant and continuous supervision of the Owner or his designated representative.

In these specifications, the terms "approved" and "as directed" shall refer to directions to the Contractor from the Owner or his designated representative.

2.0 SUBSURFACE CONDITIONS

Prior to bidding the work, the Contractor shall examine, investigate and inspect the construction site as to the nature and location of the work, and the general and local conditions at the construction site, including without limitation, the character of surface or subsurface conditions and obstacles to be encountered on and around the construction site; and shall make such additional investigation as he may deem necessary for the planning and proper execution of the work. Borings and/or soil investigations shall have been made. Results of these borings and studies will be made available by the Owner to the Contractor upon his request, but the Owner is not responsible for any interpretations or conclusions with respect thereto made by the Contractor based on such information, and the



EAST KENTUCKY ENGINEERING, LLC.

Owner further has no responsibility for the accuracy of the borings and the soil investigations.

If conditions other than those indicated are discovered by the Contractor, the Owner should be notified immediately. The material which the Contractor believes to be a changed condition should not be disturbed so that the Owner can investigate the condition.

3.0 SITE PREPARATION

Within the specified areas, all trees, brush, stumps, logs, tree roots, and structures scheduled for demolition shall be removed and disposed of.

All cut, and fill areas shall be properly stripped. Topsoil will be removed to its full depth and stockpiled for use in finish grading. Any rubbish, organic and other objectionable soils, and other deleterious material shall be disposed of off the site, or as directed by the Owner or his designated representative if on-site disposal is provided. In no case shall such objectionable material be allowed in or under the fill unless specifically authorized in writing.

Prior to the addition of fill, the original ground shall be compacted to job specifications as outlined below. Special notice shall be given to the proposed fill area now. If wet spots, spongy conditions, or groundwater seepage is found, corrective measures must be taken before the placement of fill.

4.0 FORMATION OF FILL AREAS

Fills shall be formed of satisfactory materials placed in successive horizontal layers of not more than eight (8) inches in loose depth for the full width of the cross-section. The depth of lift may be increased if the Contractor can demonstrate the ability to compact a larger lift. If compaction is accomplished using hand-tamping equipment, lifts will be limited to 4-inch loose lifts. Engineered fill placed below the structure bearing elevation shall be compacted to at least 95% of the maximum dry unit weight with a moisture content within 2% of the optimum moisture content as determined by the modified Proctor test. The top size of the material placed shall not exceed 4 inches.



EAST KENTUCKY ENGINEERING, LLC.

All material entering the fill shall be free of organic matter such as leaves grass, roots, and other objectionable material.

The operations on earthwork shall be suspended at any time when satisfactory results cannot be obtained because of rain, freezing weather, or other unsatisfactory conditions. The Contractor shall keep the work areas graded to provide the drainage always.

The fill material shall be of the proper moisture content before compaction efforts are started. Wetting or drying of the material and manipulation to secure a uniform moisture content throughout the layer shall be required. Should the material be too wet to permit proper compaction or rolling, all work thus affected shall be delayed until the material has dried to the required moisture content. The moisture content of the fill material should be no more than two (2) percentage points higher or lower than optimum unless otherwise authorized. Sprinkling shall be done with equipment that will satisfactorily distribute the water over the disced area. Any areas inaccessible to a roller shall be consolidated and compacted by mechanical tampers. The equipment shall be operated in such a manner that hardpan, cemented gravel, clay or other chunky soil material will be broken up into small particles and become incorporated with the other material in the layer.

In the construction of filled areas, starting layers shall be placed in the deepest portion of the fill, and as placement progresses, additional layers shall be constructed in horizontal planes. Original slopes shall be continuous, vertically benched to provide horizontal fill planes. The size of the benches shall be formed so that the base of the bench is horizontal, and the back of the bench is vertical. As many benches as are necessary to bring the site to final grade shall be constructed. Filling operations shall begin on the lowest bench, with the fill being placed in horizontal eight (8) inch thick loose lifts unless otherwise authorized. The filling shall progress in this manner until the entire first bench has been filled, before any fill is placed on the succeeding benches. Proper drainage shall always be maintained during benching and filling of the benches, to ensure that all water is drained away from the fill area.



EAST KENTUCKY ENGINEERING, LLC.

Frozen material shall not be placed in the fill nor shall the fill be placed upon frozen material.

The Contractor shall be responsible for the stability of all fills made under the contract and shall replace any portion, which in the opinion of the Owner or his designated representative, has become displaced due to carelessness or negligence on the part of the Contractor. Fill damaged by inclement weather shall be repaired at the Contractor's expense.

5.0 SLOPE RATIO AND STORM WATER RUN-OFF

Slopes shall not be greater than 2 (horizontal) to 1 (vertical) in both cut and fill, or as illustrated on the construction drawings. Excavations shall be constructed in accordance with all Federal, State and local codes relative to slope geometry.

6.0 GRADING

The Contractor shall furnish, operate, and maintain such equipment as is necessary to construct uniform layers and control smoothness of grade for maximum compaction and drainage.

7.0 COMPACTING

The compaction equipment shall be approved equipment of such design, weight, and quantity to obtain the required density in accordance with these specifications.

8.0 TESTING AND INSPECTION SERVICES

Testing and inspection services will be provided by the Owner.



GUIDELINES FOR EXCAVATIONS AND TRENCHES

The following represents some general guidelines relative to the design and construction of excavations and trenches. It must be emphasized that these guidelines are not intended to represent a "safety plan," but rather are presented herein to provide general guidance regarding the design characteristics and safety measures for excavations and trenches.

1. Check with the following utilities prior to breaking ground:
 - Sewer
 - Telephone
 - Fuel
 - Electric
 - Water
 - Gas
 - Cable

When utility companies or owners do not respond to your request within 48 hours, the contractor may only then proceed provided the contractor does so with caution by using detection equipment or other acceptable means to locate utility installations.

Once the excavation is open, the contractor should protect and support the exposed underground utilities or remove installations to safeguard workers and prevent damage to exposed utilities.

2. Access and egress ramps must be designed by a "competent person" and structural ramps used for equipment must be designed by a "competent person" with qualified knowledge in structural design. In addition:
 - Ramps must be secured to prevent displacement.
 - Ramps used in lieu of steps must have cleats to prevent slipping; and



EAST KENTUCKY ENGINEERING, LLC.

- Trenching excavations four feet or greater in depth must have a stairway, ladder, ramps or other safe means to egress with lateral travel no more than 25 feet.
3. Workers must be provided with reflector garments, such as warning orange or red vests, when exposed to vehicular traffic.
 4. Contractors must not allow workers to work under or near equipment when there is danger of falling debris, spillage or equipment-related injuries.
 5. Mobile equipment, operating adjacent to an open excavation or approaching the edge of an excavation, must have one of the following when the operator's view is obstructed:
 - Warning System
 - Mechanical Signals
 - Barricades
 - Stop Logs
 - Hand Signals
 6. The contractor must check the atmosphere for hazardous gases and oxygen deficiencies when excavating four feet or greater around landfills, or when hazardous substances are stored nearby, and when the contractor expects there could be any exposure to the workers.
 7. When hazardous atmospheric conditions exist, or when conditions could change, the contractor must make emergency rescue equipment readily available including breathing apparatus, safety harnesses with lifelines and a basket stretcher.
 8. When workers enter bell-bottom pier holes or other deep and confined excavations, the worker must wear (always while performing work in the confined space) a separate lifeline attached to a harness. The line must be



EAST KENTUCKY ENGINEERING, LLC.

attended by someone above while work is being performed. The worker must check for hazardous atmospheric conditions prior to entry.

9. The contractor must ensure that water does not accumulate in open excavations and must inspect the excavation prior to allowing workers to re-enter after heavy rains.
10. Adjacent structures (buildings, walls, etc.) must be supported or secured to prevent worker exposure to unsafe conditions and damage to existing structures.
11. A registered professional engineer must approve operations when a contractor underpins existing structures to ensure worker safety and prevent damage to existing structures.
12. Workers must not be exposed to loose soil and rock or materials in and around excavations. Materials, such as removed soil and rock, must not be stored closer than two feet from the edge of the excavation.
13. Daily inspections of the excavation, the adjacent areas, and protective systems must be made by a "competent person" for evidence of possible cave-ins, indications of failure of protective systems, hazardous atmospheres or other hazardous conditions. The "competent person" must stop work immediately and remove workers from the excavation when conditions change and pose a threat to their safety.
14. Workers must not be exposed to fall hazards associated with excavations. Protective walkways or bridges with standard guardrails must be provided.
15. All wells, pits, shafts etc. must be barricaded or covered. After completion of work, all wells, pits, shafts etc. must be backfilled.



IV - GENERAL CONCRETE SPECIFICATIONS

1.0 GENERAL

It is the intent of this specification to secure, for every part of the work, concrete of homogenous structure which, when hardened, will have the required strength and resistance to weathering. To this end, the limiting values of concrete and the requirements hereinafter specified must be met. Standard tests of the cement, aggregates, concrete and reinforcement will be made by the Owner as it sees fit. The Contractor shall furnish the material for all required samples plus such labor as required to obtain samples. The Contractor shall provide to authorized representatives of the Owner, convenient access to all parts of the work of all concreting operations for sampling and inspection.

2.0 SCOPE

Contractor shall furnish all materials, labor, services, transportation, tools, equipment, and related items required to complete work indicated on the drawings and/or specified.

Unless otherwise noted or as modified by more stringent requirements specified herein, all plain and reinforced concrete work shall be performed in full compliance with applicable requirements of the Building Code Requirements for Reinforced Concrete ACI 318.

Contractor shall obtain Owner's approval of all subgrades, footing bottoms, forms, and reinforcement just prior to placing concrete.

Contractor shall coordinate the work specified in this section with that specified in other sections so that all anchors, pipes and other embedded items are properly installed before concrete is placed.

Contractor shall clean all exposed concrete surfaces and obtain approval of Owner for method of cleaning.



EAST KENTUCKY ENGINEERING, LLC.

3.0 MATERIALS

All materials shall be of the respective quality specified herein, delivered, stored, and handled as to prevent inclusion of foreign matter and damage by dampness or breakage. Packaged material shall be stored in original container until ready for use. Materials showing evidence of dampness or other damage may be rejected.

- A. Fine and Coarse Aggregates: Coarse and fine aggregates shall conform to ASTM Specification C33. The maximum size of aggregate shall not be larger than one-fifth ($1/5$) of the narrowest dimensions between forms, or larger than three fourths ($3/4$) of the minimum clear spacing between reinforcement.
1. Fine Aggregate: Sand shall be composed essentially of clean, hard, strong, durable grains free of structurally weak grains, organic matter, loam, clay, silt, salt, mica or other fine materials that may affect bonding of the cement paste.
 2. Coarse Aggregate: Cement concrete shall consist of crushed rock or screened gravel and shall be composed essentially of clean, hard, strong and impermeable particles, resistant to wear and frost and free from deleterious amounts of organic matter, loam, clay, salts, mica, and soft, thin, elongated, laminated or disintegrated stone, and shall be inert to water and cement.
- B. Portland Cement: Portland cement shall conform to ASTM Specification C150. Type I or Type II Portland Cement shall be used if they are not intermixed during any one batch. Type II Portland Cement shall not be used unless indicated on the plans.
- C. Water: Water for mixing and curing shall be clean, fresh, and free from deleterious materials.
- D. Metal Reinforcement: Rebar shall be Grade 60 and with deformations conforming to ASTM Specification A305. Welded wire mesh shall conform to W4 x W4 size and be of Grade 60 steel.



EAST KENTUCKY ENGINEERING, LLC.

- E. Admixtures: Except as herein noted, admixtures shall not be used.
1. Under adverse weather conditions only retarding or accelerating agents containing no chloride may be used.
 2. Air-Entraining Agent shall be used for all concrete will give an entrained air range of not less than 4 percent but no greater than 8 percent in the finished product. Under no circumstances shall the air-entraining be interground with cement.
 3. Approval in writing shall be required from Owner prior to the use of any admixture.

4.0 FORM

Forms shall be constructed with proper shoring and cross-bracing, safeguarding the total structure and specifically lateral stability and sufficiently strong to stand vibrations of concrete and to carry, without appreciable deflection or displacement, all dead and live loads to which they may be subjected.

5.0 INSERTS, ETC.

Anchors, bolts, dowels, conduit, water stops, vent pipes and other similar built-in or concreted-in items shall be properly located, accurately positioned and secured. The Contractor shall cooperate in placing of such items with other contractors who require a fastening device for their work, and he shall maintain them in proper location during the progress of his work.

6.0 REINFORCEMENT

Reinforcement at the time concrete is placed shall be free from rust, scale or other coatings that will destroy or reduce the bond.



EAST KENTUCKY ENGINEERING, LLC.

Reinforcement shall be accurately placed and securely tied at intersections and shall be securely held in position during the placing of concrete by pacers, chairs, or other approved supports.

The reinforcement of foundations, footings and other principal structural members in which the concrete is deposited against the ground shall not have less than three (3) inches of concrete between it and the ground contact surface. If concrete surfaces after removal of the forms are to be exposed to the weather or to be in contact with the ground or rock, reinforcement shall be protected with not less than two (2) inches of concrete,

7.0 CONCRETE

Concrete for the various parts of the work shall be of 4000 pounds per square inch compressive strength with a minimum 28-day cure. Contractor is responsible to provide a mix of not less than 6 bags of cement per yard of concrete and not more than 7 gallons of water per bag of cement, producing a minimum slump of 2-1/2 inches and a maximum slump of 4-1/2 inches. Concrete that exceeds the above range of maximum or minimum slump requirements may be rejected by the Owner. All concrete shall be air-entrained. Contractors are required to furnish the name or names of the company(s) that will be providing the mix. The Owner reserves the right to disapprove any concrete supplier that has been known to supply an undesirable material to the Owner on previous occasions.

8.0 DEPOSITING CONCRETE

4.1. Preparation for Placing Concrete: Before depositing concrete, the Contractor shall:

1. Remove from space to be occupied by concrete all debris, including snow, ice, and water unless otherwise permitted by Owner.
2. Provide diversion, satisfactory to Owner, of any flow of water to an excavation to avoid washing the freshly deposited concrete.



EAST KENTUCKY ENGINEERING, LLC.

3. Coat the forms prior to placing of reinforcing steel as required in form work.
 4. Secure firmly in correct position, all reinforcement and other items to be encased and remove therefrom all coating including ice and frost.
- B. Transportation of Concrete from Batch Plant: The concrete shall be delivered to the site of the work and discharge shall be completed within 90 minutes after addition of the cement and water to the aggregates. Each batch of concrete delivered at the job site shall be accompanied by a time slip issued at the batching plant, bearing the time of charging of the mixer drum with the cement and aggregates.
- C. Transporting of Concrete from Mixer to Place of Final Deposit: Transportation shall be done as rapidly as practical by means which shall prevent the separation or loss of the ingredients. If chutes are used, they shall be at a slope not flatter than one vertical to two horizontal. Buggies or carts shall be equipped with pneumatic rubber tires or surfaces of runways shall be sufficiently smooth or both so as not to cause separation or segregation of concrete ingredients. Concrete shall not be allowed to drop freely more than 4 feet. Where greater drops are required, canvas "elephant trunks" or galvanized iron chutes equipped with suitable hopper heads shall be employed and a sufficient number placed to ensure that the concrete may be effectively compacted into horizontal layers not exceeding 12 inches in thickness with minimum lateral movements.
- D. Depositing of Concrete: Depositing of concrete shall:



EAST KENTUCKY ENGINEERING, LLC.

1. Proceed continuously after once starting until reaching the end of a section of construction joint location shown on the drawings, or as approved by the Owner. The operations shall be conducted so that no concrete is deposited on concrete sufficiently hardened to cause formation of seams, and planes of weakness.
 2. Be as near as practical to its final position in the forms.
 3. Proceed to maintain constantly a top surface which is approximately level.
 4. Be placed before initial set has occurred, and in no event after it has contained its water content for more than 90 minutes.
 5. Be thoroughly worked and compacted by means of suitable tools to provide impermeability, durability and strength and shall be thoroughly worked around reinforcements and embedded items and into corners of forms and to be free from voids, pockets or honeycombing. Care shall be taken to provide impermeability.
- E. Vibration Equipment: Vibration equipment shall be of the appropriate type and shall, always, be adequate in number of units and power of each unit to properly consolidate all concrete.
- F. Monolithic Pours: Proper delivery of concrete shall be the Contractor's responsibility to make a mono-lithic pour without delays and changes of cold joints.



EAST KENTUCKY ENGINEERING, LLC.

9.0 CURING

All concrete work shall be protected from injurious action by the sun, rain, flowing water, frost and other injury and shall be covered with plastic after application of curing compound for three (3) days on pours located above ground.

Contractor shall not remove any formwork for a minimum period of 24 hours after a concrete pour without written approval of the Owner.

10.0 CONCRETE FINISHES

Finishes of all exposed concrete shall be free of defects which impair its durability or adversely affect its appearance. All such surfaces when stripped, shall be uniform in appearance and any surfaces displaying any deviations from adjacent uniform surfaces shall be rejected and subject to removal.

Finished work shall be level and plumb, true to lines, and dimensions. Finished plane surfaces shall be smooth, and as nearly perfect as practical; however, deviations from a true plane shall not exceed 1/8 inch when measured from a 6-foot straight edge placed against the surface to any point on the surface and under the straight edge.

All exposed surfaces shall have defects corrected, protrusions removed, and holes filled.



EAST KENTUCKY ENGINEERING, LLC.

APPENDIX A PHOTOGRAPHS



Trench Photograph



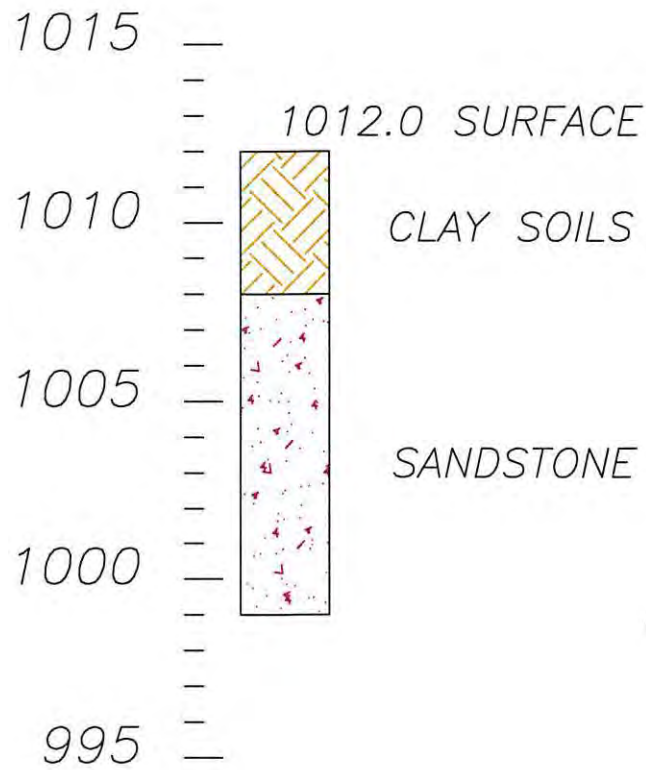
Trench Photograph



EAST KENTUCKY ENGINEERING, LLC.

APPENDIX B BORING LOG

BORING LOG



Drawn:	Date: 11/15/20
Job:	Scale: 1" = 5'
Drawing:	
Tool Palette EKYENG	

APPALACHIAN WIRELESS
BORING LOG
FULLERS RIDGE TOWER SITE
FLOYD COUNTY KENTUCKY



East Kentucky Engineering, LLC

230 Swartz Drive
Hazard, KY 41701
(606) 551-1050



EAST KENTUCKY ENGINEERING, LLC.

APPENDIX C SEISMIC



Latitude, Longitude: 38.15902, -82.66479



Date	11/23/2020, 3:47:22 AM
Design Code Reference Document	IBC-2015
Risk Category	IV
Site Class	A - Hard Rock

Type	Value	Description
S _S	0.161	MCE _R ground motion. (for 0.2 second period)
S ₁	0.076	MCE _R ground motion. (for 1.0s period)
S _{MS}	0.129	Site-modified spectral acceleration value
S _{M1}	0.061	Site-modified spectral acceleration value
S _{DS}	0.086	Numeric seismic design value at 0.2 second SA
S _{D1}	0.041	Numeric seismic design value at 1.0 second SA

Type	Value	Description
SDC	A	Seismic design category
F _a	0.8	Site amplification factor at 0.2 second
F _v	0.8	Site amplification factor at 1.0 second
PGA	0.076	MCE _G peak ground acceleration
F _{PGA}	0.8	Site amplification factor at PGA
PGA _M	0.061	Site modified peak ground acceleration
T _L	12	Long-period transition period in seconds
S _{sRT}	0.161	Probabilistic risk-targeted ground motion. (0.2 second)
S _{sUH}	0.175	Factored uniform-hazard (2% probability of exceedance in 50 years) spectral acceleration
S _{sD}	1.5	Factored deterministic acceleration value. (0.2 second)
S _{1RT}	0.076	Probabilistic risk-targeted ground motion. (1.0 second)
S _{1UH}	0.085	Factored uniform-hazard (2% probability of exceedance in 50 years) spectral acceleration.
S _{1D}	0.6	Factored deterministic acceleration value. (1.0 second)
PGA _d	0.6	Factored deterministic acceleration value. (Peak Ground Acceleration)
C _{RS}	0.923	Mapped value of the risk coefficient at short periods
C _{R1}	0.903	Mapped value of the risk coefficient at a period of 1 s

DISCLAIMER

While the information presented on this website is believed to be correct, SEAC / OSHPD and its sponsors and contributors assume no responsibility or liability for its accuracy. The material presented in this web application should not be used or relied upon for any specific application without competent examination and verification of its accuracy, suitability and applicability by engineers or other licensed professionals. SEAC / OSHPD do not intend that the use of this information replace the sound judgment of such competent professionals, having experience and knowledge in the field of practice, nor to substitute for the standard of care required of such professionals in interpreting and applying the results of the seismic data provided by this website. Users of the information from this website assume all liability arising from such use. Use of the output of this website does not imply approval by the governing building code bodies responsible for building code approval and interpretation for the building site described by latitude/longitude location in the search results of this website.



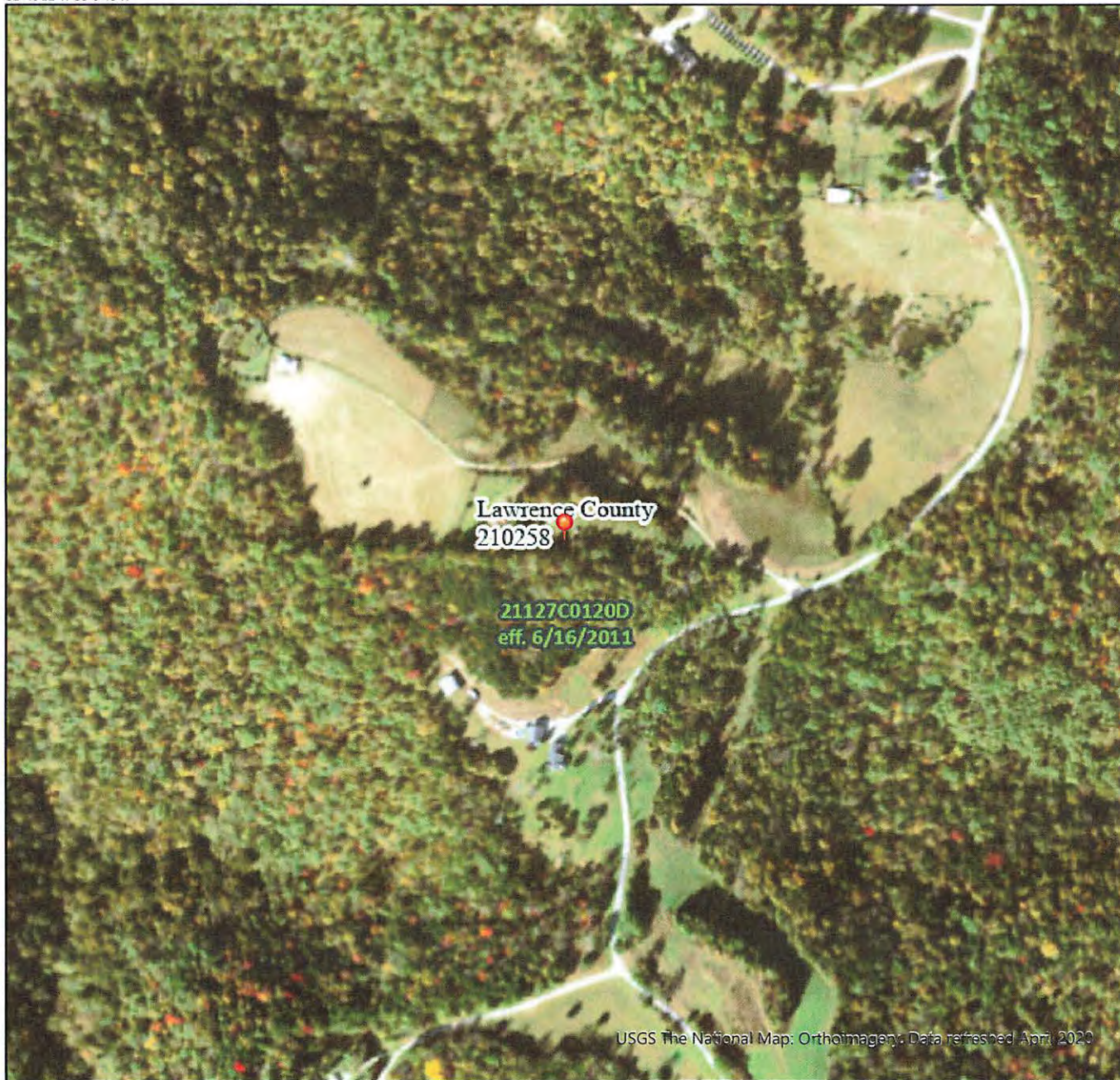
EAST KENTUCKY ENGINEERING, LLC.

APPENDIX D MAPS

National Flood Hazard Layer FIRMette



82°40'12"W 38°9'46"N



USGS The National Map: Orthoimagery; Data refreshed April 2020



Legend

SEE FIS REPORT FOR DETAILED LEGEND AND INDEX MAP FOR FIRM PANEL LAYOUT

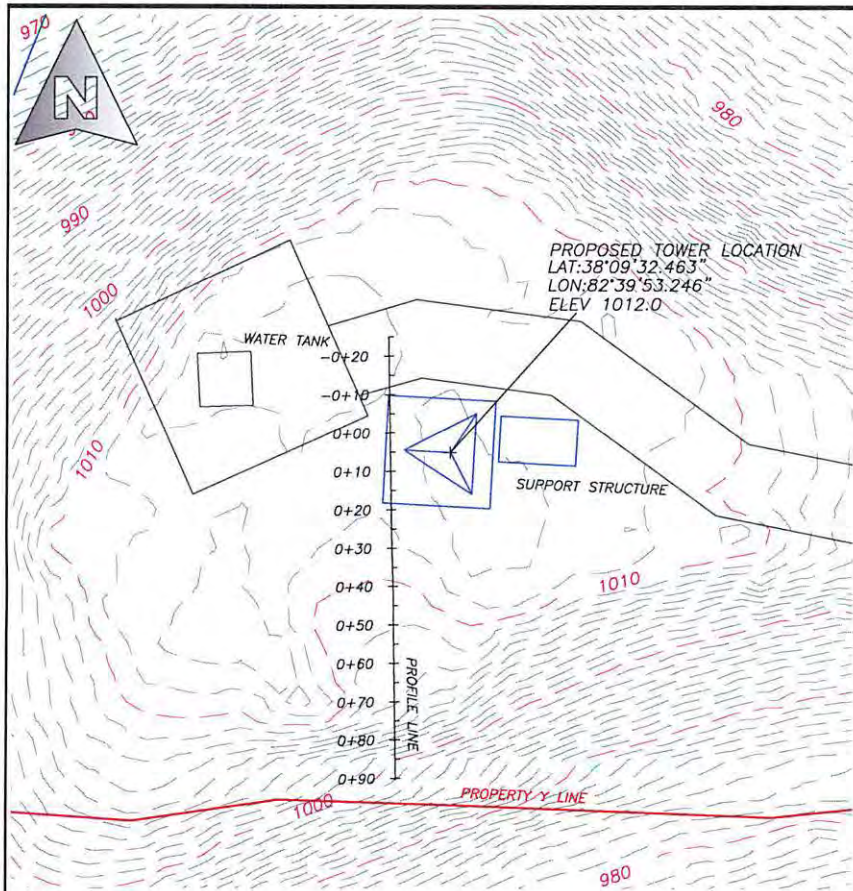
SPECIAL FLOOD HAZARD AREAS		Without Base Flood Elevation (BFE) Zone A, V, A99
		With BFE or Depth Zone AE, AO, AH, VE, AR
		Regulatory Floodway
OTHER AREAS OF FLOOD HAZARD		0.2% Annual Chance Flood Hazard, Areas of 1% annual chance flood with average depth less than one foot or with drainage areas of less than one square mile Zone X
		Future Conditions 1% Annual Chance Flood Hazard Zone X
		Area with Reduced Flood Risk due to Levee. See Notes, Zone X
		Area with Flood Risk due to Levee Zone D
OTHER AREAS		NO SCREEN Area of Minimal Flood Hazard Zone X
		Effective LOMRs
		Area of Undetermined Flood Hazard Zone D
GENERAL STRUCTURES		Channel, Culvert, or Storm Sewer
		Levee, Dike, or Floodwall
OTHER FEATURES		20.2 Cross Sections with 1% Annual Chance Water Surface Elevation
		17.5
		Coastal Transect
		Base Flood Elevation Line (BFE)
		Limit of Study
		Jurisdiction Boundary
MAP PANELS		Coastal Transect Baseline
		Profile Baseline
		Hydrographic Feature
		Digital Data Available
		No Digital Data Available
		Unmapped
		The pin displayed on the map is an approximate point selected by the user and does not represent an authoritative property location.



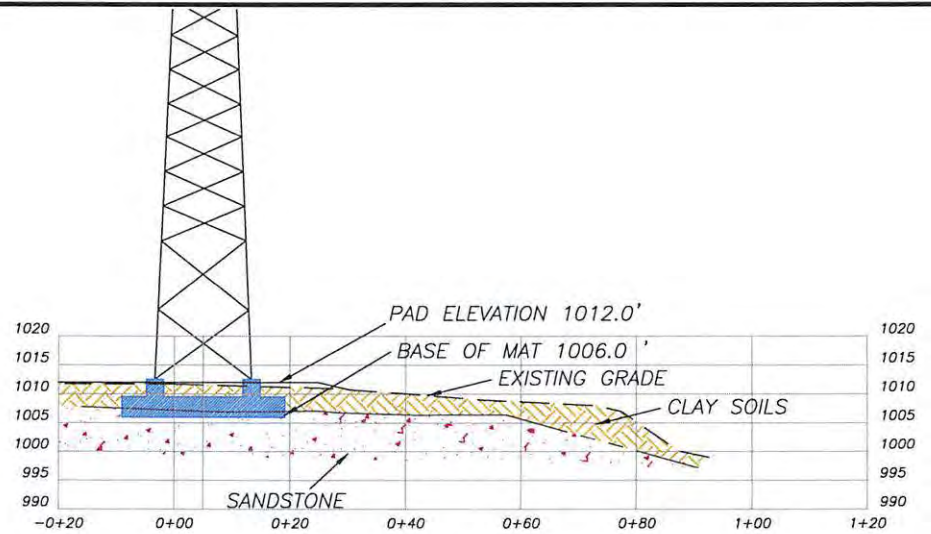
This map complies with FEMA's standards for the use of digital flood maps if it is not void as described below. The basemap shown complies with FEMA's basemap accuracy standards

The flood hazard information is derived directly from the authoritative NFHL web services provided by FEMA. This map was exported on 10/12/2020 at 2:45 PM and does not reflect changes or amendments subsequent to this date and time. The NFHL and effective information may change or become superseded by new data over time.

This map image is void if the one or more of the following map elements do not appear: basemap imagery, flood zone labels, legend, scale bar, map creation date, community identifiers, FIRM panel number, and FIRM effective date. Map images for unmapped and unmodernized areas cannot be used for regulatory purposes.



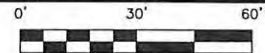
PLAN VIEW
1"=30'



PROFILE
1"=20'

East Kentucky Engineering, LLC

230 Swartz
Hazard, KY 41701
(606) 551-1050
Email: ekyeng@ekyang.net



Drawn by: RDS 11/6/2020
Job #: 165-000-0118 Scale: 1" = AS NOTED
File Location:

APPALACHIAN WIRELESS
PROPOSED FULLERS RIDGE TOWER LOCATION
LAWRENCE COUNTY
KENTUCKY

Exhibit 5



1 Fairholm Avenue
Peoria, IL 61603 USA
Phone 309-566-3000
FAX 309-566-3079

December 3, 2020

East Kentucky Network
Attn: Stanton Neece
101 Technology Trail
Ivel, KY 41642

Reference: 190 FT RT SELF SUPPORT TOWER
FULLERS RIDGE, KENTUCKY

File Number: 236161

<u>Copies</u>	<u>Drawing Number</u>	<u>Description</u>
1	236161-01-D1	Design Sealed for the State of KENTUCKY
1	236161-01-F1	Foundation

Email: sneece@ekn.com

Sincerely,

JD Long

jdd



1 Fairholm Avenue
Peoria, IL 61603 USA
Phone: (309)-566-3000
Fax: (309)-566-3079

DATE: DECEMBER 03, 2020

PURCHASER: EAST KENTUCKY NETWORK

PROJECT: 190 FT RT SELF SUPPORT TOWER
FULLERS RIDGE, KENTUCKY

FILE NUMBER:236161

DRAWINGS: 236161-01-D1 , 236161-01-F1

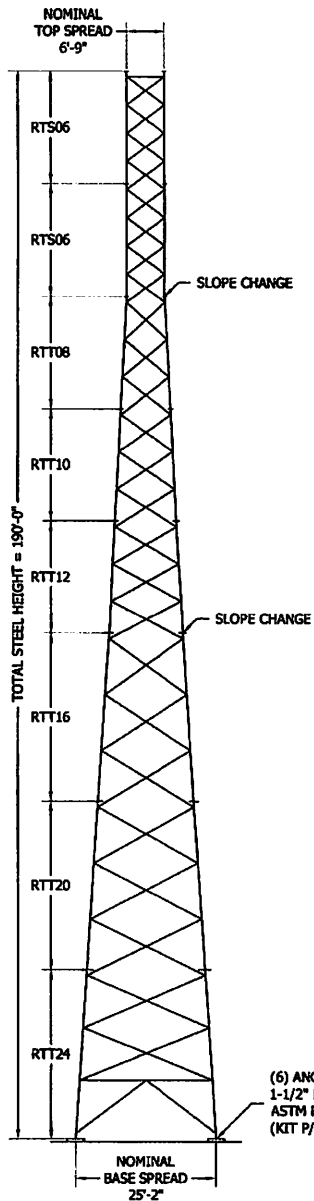
I CERTIFY THAT THE REFERENCED DRAWINGS WERE PREPARED UNDER MY SUPERVISION IN ACCORDANCE WITH THE DESIGN AND LOADING CRITERIA SPECIFIED BY THE PURCHASER AND THAT I AM A REGISTERED PROFESSIONAL ENGINEER UNDER THE LAWS OF THE STATE OF KENTUCKY.

CERTIFIED BY: _____

DATE: _____

12/3/20



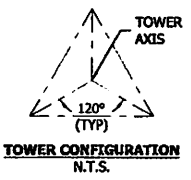


(6) ANCHOR BOLTS (18 TOTAL)
1-1/2" DIA. X 74" LONG
ASTM F1554 Gr. 105
(KIT P/N: 18K2516RTFST)

GENERAL NOTES

1. ROHN PRODUCTS, LLC TOWER DESIGNS CONFORM TO ANSI/TIA-222-G UNLESS OTHERWISE SPECIFIED UNDER TOWER DESIGN LOADING.
2. THE DESIGN LOADING CRITERIA INDICATED HAS BEEN PROVIDED TO ROHN. THE DESIGN LOADING CRITERIA HAS BEEN ASSUMED TO BE BASED ON SITE-SPECIFIC DATA IN ACCORDANCE WITH ANSI/TIA-222-G AND MUST BE VERIFIED BY OTHERS PRIOR TO INSTALLATION.
3. ANTENNAS AND LINES LISTED IN TOWER DESIGN LOADING TABLE ARE PROVIDED BY OTHERS UNLESS OTHERWISE SPECIFIED.
4. STEP BOLTS WITH SAFETY CLIMB SYSTEM ARE PROVIDED AS A CLIMBING FACILITY FOR THE INSTALLATION OF THE STRUCTURE.
5. TOWER MEMBER DESIGN DOES NOT INCLUDE STRESSES DUE TO ERECTION SINCE ERECTION EQUIPMENT AND CONDITIONS ARE UNKNOWN. DESIGN ASSUMES COMPETENT AND QUALIFIED PERSONNEL WILL ERECT THE TOWER.
6. WORK SHALL BE IN ACCORDANCE WITH ANSI/TIA-222-G, "STRUCTURAL STANDARDS FOR STEEL ANTENNA TOWERS AND ANTENNA SUPPORTING STRUCTURES".
7. THE MINIMUM YIELD STRENGTH OF STRUCTURAL STEEL MEMBERS SHALL BE 50 KSI.
8. FIELD CONNECTIONS SHALL BE BOLTED. NO FIELD WELDS SHALL BE ALLOWED.
9. STRUCTURAL BOLTS SHALL CONFORM TO GRADE A325 PER ASTM F3125, EXCEPT WHERE NOTED.
10. PAL NUTS ARE PROVIDED FOR ALL TOWER BOLTS.
11. STRUCTURAL STEEL AND CONNECTION BOLTS SHALL BE HOT-DIPPED GALVANIZED AFTER FABRICATION, IN ACCORDANCE WITH ANSI/TIA-222-G.
12. ALL HIGH STRENGTH BOLTS, UNLESS OTHERWISE NOTED FOR DOUBLE ANGLE MEMBERS, ARE TO BE TIGHTENED TO A "SNUG TIGHT" CONDITION AS DEFINED IN THE RCSC "SPECIFICATION FOR STRUCTURAL JOINTS USING HIGH-STRENGTH BOLTS". NO OTHER MINIMUM BOLT TENSION OR TORQUE VALUES ARE REQUIRED.
13. PURCHASER SHALL VERIFY THE INSTALLATION IS IN CONFORMANCE WITH LOCAL, STATE, AND FEDERAL REQUIREMENTS FOR OBSTRUCTION MARKING AND LIGHTING.
14. TOLERANCE ON TOWER STEEL HEIGHT IS EQUAL TO PLUS 1% OR MINUS 1/2%.
15. DESIGN ASSUMES THAT, AS A MINIMUM, MAINTENANCE AND INSPECTION WILL BE PERFORMED OVER THE LIFE OF THE STRUCTURE IN ACCORDANCE WITH ANSI/TIA-222-G.
16. DESIGN ASSUMES LEVEL GRADE AT TOWER SITE.
17. DESIGN ASSUMES ALL ANTENNAS ARE MOUNTED SYMMETRICALLY TO MINIMIZE TORQUE, IF APPLICABLE.
18. FOUNDATIONS SHALL BE DESIGNED TO SUPPORT THE REACTIONS SHOWN FOR THE CONDITIONS EXISTING AT THE SITE.

MAXIMUM FACTORED REACTIONS	
COMPRESSION PER LEG	= 456.7 KIPS
TENSION PER LEG	= 399.7 KIPS
SHEAR PER LEG	= 53.1 KIPS
TOTAL SHEAR	= 87.1 KIPS
TOTAL O.T.M	= 9,437.2 FT-KIPS



TOWER DESIGN LOADING		
DESIGN WIND LOAD PER ANSI/TIA-222-G USING THE FOLLOWING DESIGN CRITERIA: ASCE 7-16 ULTIMATE WIND SPEED (NO ICE): 106 MPH BASIC WIND SPEED (W/ICE): 30 MPH PER ASCE 7-16 DESIGN ICE THICKNESS: 1.50" PER ASCE 7-16 EXPOSURE CATEGORY: C STRUCTURE CLASS: II TOPOGRAPHIC CATEGORY: 5 (PER ASCE 7-16 SECTION 26.8.) TYPE OF FEATURE: 3-D AXISYMMETRIC HILL CREST HEIGHT OF FEATURE ABOVE SURROUNDING TERRAIN (H): 367 FT. DISTANCE OF STRUCTURE FROM CREST OF FEATURE (X): 0.00 FT. DISTANCE UPWIND OF CREST FROM HALF HEIGHT OF FEATURE (LH): 850 FT. EARTHQUAKE SPECTRAL RESPONSE ACCELERATION: Ss: 0.162, S1: 0.072, SITE CLASS: D		
THIS STRUCTURE HAS BEEN DESIGNED TO SUPPORT THE FOLLOWING LOADS:		
ELEVATION (FT)	ANTENNA LOADING	LINE SIZE (NOM)
TOP	LIGHTNING ROD	-
185	(12) NN-65A-M & (12) RRU5 2212 ON (3) SECTOR FRAMES	(6) 1-5/8", (4) 7/8"
175	(12) NN-65A-M & (12) RRU5 2212 ON (3) SECTOR FRAMES	(6) 1-5/8", (4) 7/8"
165	(12) NN-65A-M & (12) RRU5 2212 ON (3) SECTOR FRAMES	(4) 7/8"
145	(2) 8FT HP DISHES [AZ. 0 & 180 DEG][6 GHz]	(2) EW63
135	(12) NN-65A-M & (12) RRU5 2212 ON (3) SECTOR FRAMES	(4) 7/8"
125	(12) NN-65A-M & (12) RRU5 2212 ON (3) SECTOR FRAMES	(4) 7/8"
115	(12) NN-65A-M & (12) RRU5 2212 ON (3) SECTOR FRAMES	(4) 7/8"

SECTION MAIN MEMBER SCHEDULE			
SECTION	LEGS	DIAGONALS	HORIZONTALS
RTS06	PIPE 2.875x0.203	L1 3/4x1 3/4x3/16 (4)	L1 3/4x1 3/4x3/16 (1)
RTS06	PIPE 3.500x0.216	L2x2x3/16 (4)	N/A
RTT08	PIPE 4.500x0.337	L2 1/2x2 1/2x1/4 (3)	N/A
RTT10	PIPE 5.563x0.375	L3x3x1/4 (3)	N/A
RTT12	PIPE 6.625x0.432	L3x3x1/4 (3)	N/A
RTT16	PIPE 8.625x0.375	L3 1/2x3 1/2x1/4 (3)	N/A
RTT20	PIPE 8.625x0.500	L3 1/2x3 1/2x1/4 (3)	N/A
RTT24	PIPE 8.625x0.500	L4x4x3/8 (3)	L3 1/2x3 1/2x1/4 (1)

NOTE:
SECTION NUMBERS ARE FOR REFERENCE ONLY.
FOR NOMINAL FACE WIDTH DIMENSIONS, REFER TO THE STRESS ANALYSIS.
THE NUMBERS SHOWN IN PARENTHESES INDICATE THE NUMBER OF BAYS FROM TOP TO BOTTOM.

FILE NO. **236161**

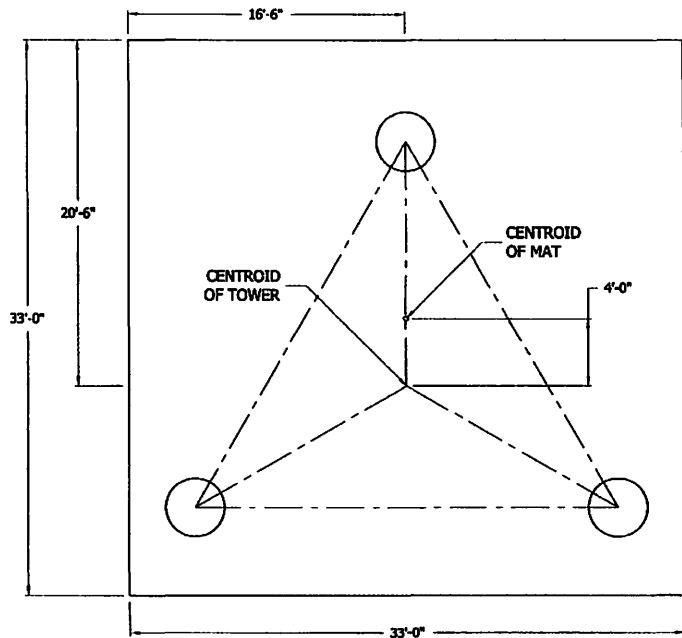
REVISIONS			
REV	DESCRIPTION	DWN	CHK

ROHN
PRODUCTS LLC
PO BOX 5999
PEORIA, IL 61601-5999
TOLL FREE 800-727-ROHN

THIS DRAWING IS THE PROPERTY OF ROHN. IT IS NOT TO BE REPRODUCED, COPIED OR TRACED IN WHOLE OR IN PART WITHOUT OUR WRITTEN CONSENT.

**EAST KENTUCKY NETWORK
DESIGN PROFILE
190 FT RT TOWER
FULLERS RIDGE, KY**

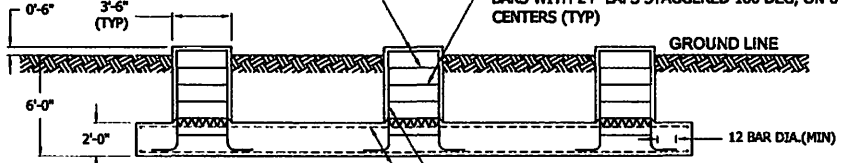
DWN: SWG	CHKD: HA	DATE: 12/03/2020
ENGR: HA	SHEET #: 1 OF 1	
PRJ. ENGR: SWG	PRJ. MANGR:	
DRAWING NO: 236161-01-D1	REV: 0	



(2) NO. 4 CIRCULAR STIRRUPS ENCLOSING VERTICAL BARS @ 2-1/2" C-C W/ 180 DEG. STAGGERED 6" MIN LAPS TERMINATED AT EACH END WITH A STD. ACI 318 HOOK ENGAGING A VERTICAL BAR WITH 2" COVER (TYP).

PLAN VIEW

NO. 4 CIRCULAR STIRRUPS ENCLOSING VERTICAL BARS WITH 24" LAPS STAGGERED 180 DEG. ON 6" CENTERS (TYP)



ELEVATION VIEW

(40) NO. 8 HORIZONTAL BARS EQUALLY SPACED EACH WAY, TOP & BOTTOM (160 TOTAL)

(14) NO. 9 VERTICAL BARS EQUALLY SPACED ON 33" DIA. CIRCULAR CAGE (CENTERLINE OF VERT. BARS) W/ STD ACI 318 HOOKS AT BOTTOM (TYP)

FACTORED REACTIONS

Maximum O.T.M =	9,437.2 FT-K
Total Tower Wt =	59.0 KIPS
Total Shear =	87.1 KIPS
Max. Shear/Leg =	53.1 KIPS
Max. Ten./Leg =	399.7 KIPS
Max. Comp./Leg =	458.7 KIPS

CONCRETE VOLUME

ROUND PIER	4.8 CU.YDS
PAD	80.7 CU.YDS
TOTAL	85.5 CU.YDS

GENERAL NOTES

- FOUNDATION DESIGN HAS BEEN DEVELOPED IN ACCORDANCE WITH GENERALLY ACCEPTED PROFESSIONAL ENGINEERING PRINCIPLES AND PRACTICES WITHIN THE LIMITS OF THE SUBSURFACE DATA PROVIDED. FOUNDATION DESIGN MODIFICATIONS MAY BE REQUIRED IN THE EVENT THE FOLLOWING DESIGN PARAMETERS ARE NOT APPLICABLE FOR THE SUBSURFACE CONDITIONS ENCOUNTERED.
 - ULTIMATE SOIL BEARING PRESSURE AT 6 FT DEPTH = 16,000 PSF.
 - GROUND WATER TABLE IS AT OR BELOW FOUNDATION DEPTH.
 - MAXIMUM FROST PENETRATION DEPTH LESS THAN FOUNDATION DEPTH.
- WORK SHALL BE IN ACCORDANCE WITH THE PROJECT CONSTRUCTION DOCUMENTS, LOCAL CODES, SAFETY REGULATIONS AND UNLESS OTHERWISE NOTED, THE LATEST REVISION OF ACI 318, "BUILDING CODE REQUIREMENTS FOR REINFORCED CONCRETE". PROCEDURES FOR THE PROTECTION OF EXCAVATIONS, EXISTING CONSTRUCTION AND UTILITIES SHALL BE ESTABLISHED PRIOR TO FOUNDATION INSTALLATION.
- CONCRETE MATERIALS SHALL CONFORM TO THE APPROPRIATE STATE REQUIREMENTS FOR EXPOSED STRUCTURAL CONCRETE.
- PROPORTIONS OF CONCRETE MATERIALS SHALL BE SUITABLE FOR THE INSTALLATION METHOD UTILIZED AND SHALL RESULT IN DURABLE CONCRETE FOR RESISTANCE TO LOCAL ANTICIPATED AGGRESSIVE ACTIONS. THE DURABILITY REQUIREMENTS OF ACI 318 SHALL BE SATISFIED BASED ON THE CONDITIONS EXPECTED AT THE SITE. AS A MINIMUM, CONCRETE SHALL DEVELOP A MINIMUM COMPRESSIVE STRENGTH OF 4,500 PSI IN 28 DAYS.
- MAXIMUM SIZE OF AGGREGATE SHALL NOT EXCEED SIZE SUITABLE FOR INSTALLATION METHOD UTILIZED OR 3/4 CLEAR DISTANCE BEHIND OR BETWEEN REINFORCING. WORKABILITY AND METHODS OF CONSOLIDATION SUCH AS VIBRATING SHALL BE UTILIZED TO PREVENT HONEYCOMBS OR VOIDS.
- REINFORCEMENT SHALL BE DEFORMED AND CONFORM TO THE REQUIREMENTS OF ASTM A615 GRADE 60 UNLESS OTHERWISE NOTED. SPLICES IN REINFORCEMENT SHALL NOT BE ALLOWED UNLESS OTHERWISE INDICATED.
- WELDING IS PROHIBITED ON REINFORCING STEEL AND EMBEDMENTS.
- MINIMUM CONCRETE COVER FOR REINFORCEMENT SHALL BE 3 INCHES UNLESS OTHERWISE NOTED. APPROVED SPACERS SHALL BE USED TO INSURE A 3 INCH MINIMUM COVER ON REINFORCEMENT.
- CONCRETE COVER FROM TOP OF FOUNDATION TO ENDS OF VERTICAL REINFORCEMENT SHALL NOT EXCEED 3 INCHES NOR BE LESS THAN 2 INCHES.
- FOUNDATION DESIGN ASSUMES STRUCTURAL BACKFILL TO BE COMPACTED IN 8 INCH MAXIMUM LAYERS TO 95% OF MAXIMUM DRY DENSITY AT OPTIMUM MOISTURE CONTENT IN ACCORDANCE WITH ASTM D1557. ADDITIONALLY, STRUCTURAL BACKFILL MUST HAVE A MINIMUM COMPACTED UNIT WEIGHT OF 110 POUNDS PER CUBIC FOOT.
- FOUNDATION DESIGN HAS BEEN BASED ON GEOTECHNICAL REPORT NO. 165-000-0118 DATED 11/16/2020 BY EAST KENTUCKY ENGINEERING, LLC.
- FOUNDATION DEPTH INDICATED IS BASED ON THE GRADE LINE DESCRIBED IN THE REFERENCED GEOTECHNICAL REPORT. FOUNDATION MODIFICATION MAY BE REQUIRED IN THE EVENT CUT OR FILL OPERATIONS HAVE TAKEN PLACE SUBSEQUENT TO THE GEOTECHNICAL INVESTIGATION.
- FOUNDATION DESIGN ASSUMES THE RECOMMENDATIONS IN THE REFERENCED GEOTECHNICAL REPORT CONCERNING VERIFICATION OF SUBSURFACE CONDITIONS ARE IMPLEMENTED PRIOR TO PLACEMENT OF CONCRETE.
- FOUNDATION INSTALLATION SHALL BE SUPERVISED BY PERSONNEL KNOWLEDGEABLE AND EXPERIENCED WITH THE PROPOSED FOUNDATION TYPE. CONSTRUCTION SHALL BE IN ACCORDANCE WITH GENERALLY ACCEPTED INSTALLATION PRACTICES.
- ALL CONSTRUCTION AND SAFETY EQUIPMENT AND TEMPORARY SUPPORTS REQUIRED FOR CONSTRUCTION SHALL BE DETERMINED, FURNISHED AND INSTALLED BY THE CONTRACTOR BASED ON THE MEANS AND METHODS CHOSEN BY THE CONTRACTOR. ALL CONSTRUCTION ACTIVITIES SHALL BE PERFORMED BY COMPETENT, QUALIFIED AND TRAINED PERSONNEL.
- FOUNDATION DESIGN ASSUMES INSTALLATION PROCEDURES WILL INCORPORATE THE PROCEDURES RECOMMENDED IN THE REFERENCED GEOTECHNICAL REPORT.
- FOUNDATION DESIGN ASSUMES FIELD INSPECTIONS WILL BE PERFORMED TO VERIFY THAT CONSTRUCTION MATERIALS, INSTALLATION METHODS AND ASSUMED DESIGN PARAMETERS ARE ACCEPTABLE BASED ON CONDITIONS EXISTING AT THE SITE.
- FOR FOUNDATION AND ANCHOR TOLERANCES SEE ANCHOR ROD LAYOUT DRAWING.
- LOOSE MATERIAL SHALL BE REMOVED FROM BOTTOM OF EXCAVATION PRIOR TO CONCRETE PLACEMENT. SIDES OF EXCAVATION SHALL BE ROUGH AND FREE OF LOOSE CUTTINGS.
- CONCRETE SHALL BE PLACED IN A MANNER THAT WILL PREVENT SEGREGATION OF CONCRETE MATERIALS, INFILTRATION OF WATER OR SOIL AND OTHER OCCURRENCES WHICH MAY DECREASE THE STRENGTH OR DURABILITY OF THE FOUNDATION.
- CONCRETE PREFERABLY SHALL BE PLACED AGAINST UNDISTURBED SOIL. WHEN FORMS ARE NECESSARY, THEY SHALL BE REMOVED PRIOR TO PLACING STRUCTURAL BACKFILL.
- CONSTRUCTION JOINTS, IF REQUIRED AT THE BASE OF THE PIERS, SHALL BE INTENTIONALLY ROUGHENED TO A FULL AMPLITUDE OF 1/4 INCH. FOUNDATION DESIGN ASSUMES NO OTHER CONSTRUCTION JOINTS.
- TOP OF FOUNDATION SHALL BE SLOPED TO DRAIN WITH A FLOATED FINISH.
- EXPOSED EDGES OF CONCRETE SHALL BE CHAMFERED 3/4" X 3/4" MINIMUM.

NOTE: SEE STRUCTURE ASSEMBLY DRAWING FOR FOUNDATION LAYOUT AND ANCHORAGE EMBEDMENT DRAWING NUMBER.

FILE NO.	236161		
REVISIONS			
REV	DESCRIPTION	DWN	CHK



PO BOX 5999
PEORIA, IL 61601-5999
TOLL FREE 800-727-ROHN

THIS DRAWING IS THE PROPERTY OF ROHN. IT IS NOT TO BE REPRODUCED, COPIED OR TRACED IN WHOLE OR IN PART WITHOUT OUR WRITTEN CONSENT.

EAST KENTUCKY NETWORK
MAT W/RAISED PIERS
FOUNDATION DESIGN
FULLERS RIDGE- KY

DWN:	SWG	CHKD:	HA	DATE:	12/3/2020
ENGR:	HA	SHEET #:		1 OF 1	
PRJ. ENGR:	SWG	PRJ. MANGR:			
DRAWING NO:	236161-01-F1			REV:	0

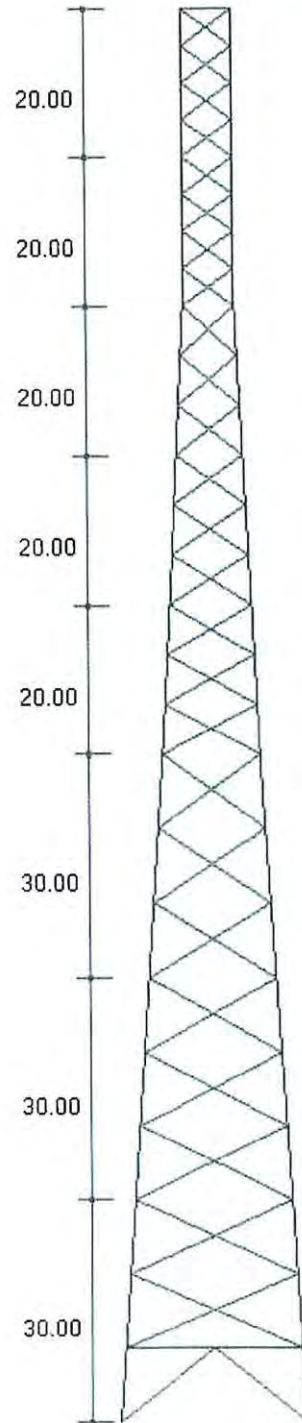
File: W:\Jobs\2020\236161\ENGINEERING\236161.out
Contract: 236161
Project: 190 FT RT TOWER
Date and Time: 12/3/2020 10:08:30 AM

Revision: 0
Site: FULLERS RIDGE- KY
Engineer: SWG *HA*

DESIGN SPECIFICATION

Design Standard: ANSITIA-222-G-2005 Add.2
Ultimate Design Wind Speed (No Ice) = 106.0 (mph)
Nominal Design Wind Speed (No Ice) = 82.1 (mph)
Basic Wind Speed (With Ice) = 30.0 (mph)
Design Ice Thickness = 0.75 (in)
Structure Class = II
Exposure Category = C
Topographic Category = 5

Sct.	Length (ft)	Top W. (in)	Bot Width (in)
1	30.00	253.97	301.97
2	30.00	205.97	253.97
3	30.00	157.97	205.97
4	20.00	132.24	157.97
5	20.00	107.32	132.24
6	20.00	82.40	107.32
7	20.00	81.53	82.40
8	20.00	80.99	81.53



MAXIMUM BASE REACTIONS

Download (Kips) 456.6
Uplift (Kips) 399.7
Shear (Kips) 53.1



TSTower - v 5.8.6 Tower Analysis Program
 (c) 1997-2020 TowerSoft www.TSTower.com



Licensed to: ROHN Products LLC
 Peoria, IL

File: W:\Jobs\2020\236161\ENGINEERING\236161.out
 Contract: 236161
 Project: 190 FT RT TOWER
 Date and Time: 12/3/2020 10:08:30 AM

Revision: 0
 Site: FULLERS RIDGE- KY
 Engineer: SWG

Section A: PROJECT DATA

Project Title: 190 FT RT TOWER
 Customer Name: EAST KENTUCKY NETWORK
 Site: FULLERS RIDGE- KY
 Contract No.: 236161
 Revision: 0
 Engineer: SWG
 Date: Dec 3 2020
 Time: 10:07:04 AM

Design Standard: ANSI/TIA-222-G-2005 Addendum 2

GENERAL DESIGN CONDITIONS

Start wind direction: 0.00 (Deg)
 End wind direction: 330.00 (Deg)
 Increment wind direction: 30.00 (Deg)
 Elevation above ground: 0.00 (ft)
 Gust Response Factor Gh: 0.85
 Structure class: II
 Exposure category: C
 Topographic category: 5
 Type of Hill: 3-D Axisymmetrical Hill
 Height of crest above surrounding terrain: 367.00 (ft)
 Distance from Crest to the tower (x): 0.00 (ft)
 Distance upwind of crest where difference in ground elevation is half the hill height (Lh): 850.00 (ft)
 Location of tower on the hill: Downwind
 Material Density: 490.1 (lbs/ft³)
 Young's Modulus: 29000.0 (ksi)
 Poisson Ratio: 0.30
 Weight Multiplier: 1.25
 Minimum Bracing Resistance as per 4.4.1

WIND ONLY CONDITIONS:

Ultimate Design Wind Speed (No Ice): 106.00 (mph)
 Nominal Design Wind Speed (No Ice): 82.11 (mph)
 Directionality Factor Kd: 0.85
 Importance Factor I: 1.00
 Wind Load Factor: 1.60
 Dead Load Factor: 1.20
 Dead Load Factor for Uplift: 0.90

WIND AND ICE CONDITIONS:

Basic Wind Speed (With Ice): 30.00 (mph)
 Directionality Factor Kd: 0.85
 Wind Load Importance Factor Iw: 1.00
 Ice Thickness Importance Factor Ii: 1.00
 Ice Thickness: 0.75 (in)
 Ice Density: 56.19 (lbs/ft³)
 Wind Load Factor: 1.00
 Dead Load Factor: 1.20
 Ice Load Factor: 1.00

WIND ONLY SERVICEABILITY CONDITIONS:

Serviceability Wind Speed: 60.00 (mph)
 Directionality Factor Kd: 0.85
 Importance Factor I: 1.00
 Wind Load Factor: 1.00
 Dead Load Factor: 1.00

EARTHQUAKE CONDITIONS:



TSTower - v 5.8.6 Tower Analysis Program
(c) 1997-2020 TowerSoft www.TSTower.com



ROHN
Products
Licensed to: ROHN Products LLC
Peoria, IL

File: W:\Jobs\2020\236161\ENGINEERING\236161.out
Contract: 236161
Project: 190 FT RT TOWER
Date and Time: 12/3/2020 10:08:30 AM

Revision: 0
Site: FULLERS RIDGE- KY
Engineer: SWG

Site class definition: D
Spectral response acceleration Ss: 0.162
Spectral response acceleration Sl: 0.072
Acceleration-based site coefficient Fa: 1.600
Velocity-based site coefficient Fv: 2.400
Design spectral response acceleration Sds: 0.173
Design spectral response acceleration Sdl: 0.115
Seismic analysis method: 1
Fundamental frequency of structure fl: 1.092
Total seismic shear Vs (Kips) : 2.47

Analysis performed using: TowerSoft Finite Element Analysis Program



TSTower - v 5.8.6 Tower Analysis Program
 (c) 1997-2020 TowerSoft www.TSTower.com



Graduate
 Licensed to: ROHN Products LLC
 Peoria, IL

File: W:\Jobs\2020\236161\ENGINEERING\236161.out
 Contract: 236161
 Project: 190 FT RT TOWER
 Date and Time: 12/3/2020 10:08:30 AM

Revision: 0
 Site: FULLERS RIDGE- KY
 Engineer: SWG

Section B: STRUCTURE GEOMETRY

TOWER GEOMETRY

Cross-Section	Height (ft)	Tot Height (ft)	# of Section	Bot Width (in)	Top Width (in)
Triangular	190.00	190.00	8	301.97	60.99

SECTION GEOMETRY

Sec #	Sec. Name	Elevation		Widths		Legs (lbs)	Brcg. (lbs)	Masses			Brcg. Clear. (in)	
		Bottom (ft)	Top (ft)	Bottom (in)	Top (in)			Sec.Brc (lbs)	Int.Brc (lbs)	Sect. (lbs)		Database (lbs)
8	RTS06	170.00	190.00	82	81	434	586	0	0	1020	0	0.787
7	RTS06	150.00	170.00	82	82	569	614	0	0	1183	0	0.787
6	RTT08	130.00	150.00	107	82	1127	944	0	0	2071	0	0.787
5	RTT10	110.00	130.00	132	107	1562	1324	0	0	2886	0	0.787
4	RTT12	90.00	110.00	158	132	2151	1522	0	0	3673	0	0.787
3	RTT16*	60.00	90.00	206	158	3727	2353	0	0	6080	0	0.787
2	RTT20*	30.00	60.00	254	206	4899	2799	0	0	7698	0	0.787
1	RTT24*	0.00	30.00	302	254	4899	5281	0	166	10346	0	0.787
Total Mass:						19369	15423	0	166	34957	0	

PANEL GEOMETRY

Sec#	Pnl#	Type	SecBrcg	Mid. Horiz Continuous	Horiz	Height (ft)	Bottom Width (in)	Top Width (in)	Plan Bracing	Hip Bracing	Gusset Plate Area (ft^2)	Gusset Plate Weight (lbs)
8	4	X	(None)	Yes	5.0	81.1	81.0	(None)	(None)	0.300	0.00	
8	3	X	(None)	None	5.0	81.3	81.1	(None)	(None)	0.300	0.00	
8	2	X	(None)	None	5.0	81.4	81.3	(None)	(None)	0.300	0.00	
8	1	X	(None)	None	5.0	81.5	81.4	(None)	(None)	0.300	0.00	
7	4	X	(None)	None	5.0	81.7	81.5	(None)	(None)	0.300	0.00	
7	3	X	(None)	None	5.0	82.0	81.7	(None)	(None)	0.300	0.00	
7	2	X	(None)	None	5.0	82.2	82.0	(None)	(None)	0.300	0.00	
7	1	X	(None)	None	5.0	82.4	82.2	(None)	(None)	0.300	0.00	
6	3	X	(None)	None	6.7	90.7	82.4	(None)	(None)	0.300	0.00	
6	2	X	(None)	None	6.7	99.0	90.7	(None)	(None)	0.300	0.00	
6	1	X	(None)	None	6.7	107.3	99.0	(None)	(None)	0.300	0.00	
5	3	X	(None)	None	6.7	115.6	107.3	(None)	(None)	0.300	0.00	
5	2	X	(None)	None	6.7	123.9	115.6	(None)	(None)	0.300	0.00	
5	1	X	(None)	None	6.7	132.2	123.9	(None)	(None)	0.300	0.00	
4	3	X	(None)	None	6.7	140.8	132.2	(None)	(None)	0.300	0.00	
4	2	X	(None)	None	6.7	149.4	140.8	(None)	(None)	0.300	0.00	
4	1	X	(None)	None	6.7	158.0	149.4	(None)	(None)	0.300	0.00	
3	3	X	(None)	None	10.0	174.0	158.0	(None)	(None)	0.300	0.00	
3	2	X	(None)	None	10.0	190.0	174.0	(None)	(None)	0.300	0.00	
3	1	X	(None)	None	10.0	206.0	190.0	(None)	(None)	0.300	0.00	
2	3	X	(None)	None	10.0	222.0	206.0	(None)	(None)	0.300	0.00	
2	2	X	(None)	None	10.0	238.0	222.0	(None)	(None)	0.300	0.00	
2	1	X	(None)	None	10.0	254.0	238.0	(None)	(None)	0.300	0.00	
1	3	X	(None)	None	10.0	270.0	254.0	(None)	(None)	0.300	0.00	
1	2	X	(None)	None	10.0	286.0	270.0	(None)	(None)	0.300	0.00	
1	1	K	(None)	Yes	10.0	302.0	286.0	2-Subdiv.	(None)	0.300	0.00	

MEMBER PROPERTIES

Sec/Member	Type	Description	Steel Grade	Conn. Type	Bolt #-Size	Bolt Grade	End Dist.	Edge Dist.	Gusset Thick.	Gusset Grade	Bolt Space	Dble Mem.
8/4	Leg	PIPE 2.875x0.203	A500 gr.	CSTension	4-0.750	A325X	(in)	(in)	(in)	(in)	(in)	(in)

File: W:\Jobs\2020\236161\ENGINEERING\236161.out
Contract: 236161
Project: 190 FT RT TOWER
Date and Time: 12/3/2020 10:08:30 AM

Revision: 0
Site: FULLERS RIDGE- KY
Engineer: SWG

8/4	Diag	L1 3/4x1 3/4x3/16	A529 gr.50Bolted	1-0.625	A325X	1.500	0.875	0.250	A572 gr.50	2.000
8/4	Horiz	L1 3/4x1 3/4x3/16	A529 gr.50Bolted	1-0.625	A325X	1.500	0.875	0.250	A572 gr.50	2.000
8/3	Leg	PIPE 2.875x0.203	A500 gr.CSTension	4-0.750	A325X	1.500	0.875	0.250	A572 gr.50	2.000
8/3	Diag	L1 3/4x1 3/4x3/16	A529 gr.50Bolted	1-0.625	A325X	1.500	0.875	0.250	A572 gr.50	2.000
8/2	Leg	PIPE 2.875x0.203	A500 gr.CSTension	4-0.750	A325X	1.500	0.875	0.250	A572 gr.50	2.000
8/2	Diag	L1 3/4x1 3/4x3/16	A529 gr.50Bolted	1-0.625	A325X	1.500	0.875	0.250	A572 gr.50	2.000
8/1	Leg	PIPE 2.875x0.203	A500 gr.CSTension	4-0.750	A325X	1.500	0.875	0.250	A572 gr.50	2.000
8/1	Diag	L1 3/4x1 3/4x3/16	A529 gr.50Bolted	1-0.625	A325X	1.500	0.875	0.250	A572 gr.50	2.000
7/4	Leg	PIPE 3.500x0.216	A500 gr.CSTension	5-0.875	A325X	1.500	1.000	0.250	A572 gr.50	2.000
7/4	Diag	L2x2x3/16	A529 gr.50Bolted	1-0.625	A325X	1.500	1.000	0.250	A572 gr.50	2.000
7/3	Leg	PIPE 3.500x0.216	A500 gr.CSTension	5-0.875	A325X	1.500	1.000	0.250	A572 gr.50	2.000
7/3	Diag	L2x2x3/16	A529 gr.50Bolted	1-0.625	A325X	1.500	1.000	0.250	A572 gr.50	2.000
7/2	Leg	PIPE 3.500x0.216	A500 gr.CSTension	5-0.875	A325X	1.500	1.000	0.250	A572 gr.50	2.000
7/2	Diag	L2x2x3/16	A529 gr.50Bolted	1-0.625	A325X	1.500	1.000	0.250	A572 gr.50	2.000
7/1	Leg	PIPE 3.500x0.216	A500 gr.CSTension	5-0.875	A325X	1.500	1.000	0.250	A572 gr.50	2.000
7/1	Diag	L2x2x3/16	A529 gr.50Bolted	1-0.625	A325X	1.500	1.000	0.250	A572 gr.50	2.000
6/3	Leg	PIPE 4.500x0.337	A500 gr.CSTension	5-1.000	A325X	1.500	1.250	0.250	A572 gr.50	2.000
6/3	Diag	L2 1/2x2 1/2x1/4	A529 gr.50Bolted	1-0.625	A325X	1.500	1.250	0.250	A572 gr.50	2.000
6/2	Leg	PIPE 4.500x0.337	A500 gr.CSTension	5-1.000	A325X	1.500	1.250	0.250	A572 gr.50	2.000
6/2	Diag	L2 1/2x2 1/2x1/4	A529 gr.50Bolted	1-0.625	A325X	1.500	1.250	0.250	A572 gr.50	2.000
6/1	Leg	PIPE 4.500x0.337	A500 gr.CSTension	5-1.000	A325X	1.500	1.250	0.250	A572 gr.50	2.000
6/1	Diag	L2 1/2x2 1/2x1/4	A529 gr.50Bolted	1-0.625	A325X	1.500	1.250	0.250	A572 gr.50	2.000
5/3	Leg	PIPE 5.563x0.375	A500 gr.CSTension	6-1.000	A325X	1.500	1.620	0.250	A572 gr.50	2.000
5/3	Diag	L3x3x1/4	A529 gr.50Bolted	1-0.625	A325X	1.500	1.620	0.250	A572 gr.50	2.000
5/2	Leg	PIPE 5.563x0.375	A500 gr.CSTension	6-1.000	A325X	1.500	1.620	0.250	A572 gr.50	2.000
5/2	Diag	L3x3x1/4	A529 gr.50Bolted	1-0.625	A325X	1.500	1.620	0.250	A572 gr.50	2.000
5/1	Leg	PIPE 5.563x0.375	A500 gr.CSTension	6-1.000	A325X	1.500	1.620	0.250	A572 gr.50	2.000
5/1	Diag	L3x3x1/4	A529 gr.50Bolted	1-0.625	A325X	1.500	1.620	0.250	A572 gr.50	2.000
4/3	Leg	PIPE 6.625x0.432	A500 gr.CSTension	6-1.500	A325X	1.500	1.620	0.250	A572 gr.50	2.000
4/3	Diag	L3x3x1/4	A529 gr.50Bolted	1-0.625	A325X	1.500	1.620	0.250	A572 gr.50	2.000
4/2	Leg	PIPE 6.625x0.432	A500 gr.CSTension	6-1.500	A325X	1.500	1.620	0.250	A572 gr.50	2.000
4/2	Diag	L3x3x1/4	A529 gr.50Bolted	1-0.625	A325X	1.500	1.620	0.250	A572 gr.50	2.000
4/1	Leg	PIPE 6.625x0.432	A500 gr.CSTension	6-1.500	A325X	1.500	1.620	0.250	A572 gr.50	2.000
4/1	Diag	L3x3x1/4	A529 gr.50Bolted	1-0.625	A325X	1.500	1.620	0.250	A572 gr.50	2.000
3/3	Leg	PIPE 8.625x0.375	A500 gr.CSTension	6-1.500	A325X	1.125	2.000	0.375	A572 gr.50	2.000
3/3	Diag	L3 1/2x3 1/2x1/4	A529 gr.50Bolted	2-0.625	A325X	1.125	2.000	0.375	A572 gr.50	2.000
3/2	Leg	PIPE 8.625x0.375	A500 gr.CSTension	6-1.500	A325X	1.125	2.000	0.375	A572 gr.50	2.000
3/2	Diag	L3 1/2x3 1/2x1/4	A529 gr.50Bolted	2-0.625	A325X	1.125	2.000	0.375	A572 gr.50	2.000
3/1	Leg	PIPE 8.625x0.375	A500 gr.CSTension	6-1.500	A325X					

File: W:\Jobs\2020\236161\ENGINEERING\236161.out
Contract: 236161
Project: 190 FT RT TOWER
Date and Time: 12/3/2020 10:08:30 AM

Revision: 0
Site: FULLERS RIDGE- KY
Engineer: SWG

3/1	Diag	L3 1/2x3 1/2x1/4	A529 gr.50Bolted	2-0.625	A325X	1.125	2.000	0.375	A572 gr.50	2.000
2/3	Leg	PIPE 8.625x0.500	A500 gr.CSTension	6-1.500	A325X					
2/3	Diag	L3 1/2x3 1/2x1/4	A529 gr.50Bolted	2-0.625	A325X	1.125	2.000	0.375	A572 gr.50	2.000
2/2	Leg	PIPE 8.625x0.500	A500 gr.CSTension	6-1.500	A325X					
2/2	Diag	L3 1/2x3 1/2x1/4	A529 gr.50Bolted	2-0.625	A325X	1.125	2.000	0.375	A572 gr.50	2.000
2/1	Leg	PIPE 8.625x0.500	A500 gr.CSTension	6-1.500	A325X					
2/1	Diag	L3 1/2x3 1/2x1/4	A529 gr.50Bolted	2-0.625	A325X	1.125	2.000	0.375	A572 gr.50	2.000
1/3	Leg	PIPE 8.625x0.500	A500 gr.CSTension	6-1.500	A325X					
1/3	Diag	L4x4x3/8	A529 gr.50Bolted	2-0.625	A325X	1.125	2.000	0.375	A572 gr.50	2.000
1/2	Leg	PIPE 8.625x0.500	A500 gr.CSTension	6-1.500	A325X					
1/2	Diag	L4x4x3/8	A529 gr.50Bolted	2-0.625	A325X	1.125	2.000	0.375	A572 gr.50	2.000
1/1	Leg	PIPE 8.625x0.500	A500 gr.CSTension	6-1.500	A325X					
1/1	Diag	L4x4x3/8	A529 gr.50Bolted	2-0.625	A325X	1.125	2.000	0.375	A572 gr.50	2.000
1/1	Horiz	L3 1/2x3 1/2x1/4	A529 gr.50Bolted	2-0.625	A325X	1.125	2.000	0.375	A572 gr.50	2.000
1/1	PlanH1	L3x3x3/16	A529 gr.50Bolted	1-0.625	A325X	1.500	1.620	0.250	A572 gr.50	2.000



ENGINEERING SOFTWARE
 TSTower - v 5.8.6 Tower Analysis Program
 (c) 1997-2020 TowerSoft www.TSTower.com



Graduate
 Licensed to: ROHN Products LLC
 Peoria, IL

File: W:\Jobs\2020\236161\ENGINEERING\236161.out
 Contract: 236161
 Project: 190 FT RT TOWER
 Date and Time: 12/3/2020 10:08:30 AM

Revision: 0
 Site: FULLERS RIDGE- KY
 Engineer: SWG

Section C: ANTENNA DATA

Structure Azimuth from North: 0

ANTENNAS

Ant No.	Elev. (ft)	Antenna (#) Type	Ant. Azim.	Mount. Radius (ft)	Mount Type	Mount Azim.	Tx Line (#)Type	Mounting Pipe Size (in)	Mounting Pipe Length (ft)	Ka
1	145.00	(1) HP8	0	4.50		0			Full Shielded	1.00
2	145.00	(1) HP8 Vert. Offset 0.00 (ft)	180	4.50		120				1.00

ANTENNA AND MOUNT WIND AREAS AND WEIGHTS

Ant No.	Antenna/Mount	Frontal Bare Area (ft)^2	Lateral Bare Area (ft)^2	Frontal Iced Area (ft)^2	Lateral Iced Area (ft)^2	Weight Bare (lbs)	Weight Iced (lbs)	Frequency GHz	Allowable Signal Loss dB	Gh Mount Ka
1	HP8	69.63	4.85	69.63	4.85	447.53	2480.50	6.00	10	0.85
2	HP8	69.63	4.85	69.63	4.85	447.53	2480.50	6.00	10	0.85

File: W:\Jobs\2020\236161\ENGINEERING\236161.out
Contract: 236161
Project: 190 FT RT TOWER
Date and Time: 12/3/2020 10:08:30 AM

Revision: 0
Site: FULLERS RIDGE- KY
Engineer: SWG

Section D: TRANSMISSION LINE DATA

Transmission Lines Position

No.	Bot El (ft)	Top El (ft)	Desc.	Radius (ft)	Az.	Orient.	No.	No. of Rows	Vert.	Antenna	User Ka
1	0.00	190.00	3/8 CABLE	15.00	0.00	0.00	1	1	Yes		
2	0.00	185.00	TX Ladder	7.05	60.00	30.00	1	1	No		
3	135.00	185.00	LDF5P-50A	1.90	60.00	25.00	4	2	No		
4	0.00	185.00	LDF7P-50A	6.74	60.00	35.00	6	2	No		
5	0.00	175.00	TX Ladder	7.05	180.00	150.00	1	1	No		
6	125.00	175.00	LDF5P-50A	2.26	180.00	145.00	4	2	No		
7	0.00	175.00	LDF7P-50A	6.74	180.00	155.00	6	2	No		
8	0.00	165.00	TX Ladder	7.05	300.00	270.00	1	1	No		
9	115.00	165.00	LDF5P-50A	2.63	300.00	265.00	4	2	No		
10	0.00	145.00	EW63	6.74	300.00	275.00	2	1	No		
11	0.00	135.00	LDF5P-50A	7.46	60.00	25.00	8	2	No		
12	0.00	125.00	LDF5P-50A	7.46	180.00	145.00	8	2	No		
13	0.00	115.00	LDF5P-50A	8.87	300.00	265.00	8	2	No		

Transmission Lines Details

No.	Desc.	Width (in)	Depth (in)	Unit Mass (lb/ft)	Line Spacing (in)	Row Spacing (in)
1	3/8 CABLE	0.38	0.38	1.00	2.750	2.750
2	TX Ladder	4.70	1.50	4.00	2.750	2.750
3	LDF5P-50A	1.10	1.10	0.33	2.250	2.750
4	LDF7P-50A	2.01	2.01	0.92	2.250	2.750
5	TX Ladder	4.70	1.50	4.00	2.750	2.750
6	LDF5P-50A	1.10	1.10	0.33	2.250	2.750
7	LDF7P-50A	2.01	2.01	0.92	2.250	2.750
8	TX Ladder	4.70	1.50	4.00	2.750	2.750
9	LDF5P-50A	1.10	1.10	0.33	2.250	2.750
10	EW63	1.16	2.01	0.51	2.250	2.750
11	LDF5P-50A	1.10	1.10	0.33	2.250	2.750
12	LDF5P-50A	1.10	1.10	0.33	2.250	2.750
13	LDF5P-50A	1.10	1.10	0.33	2.250	2.750



TSTower - v 5.8.6 Tower Analysis Program
 (c) 1997-2020 TowerSoft www.TSTower.com



ROHN Products
 Licensed to: ROHN Products LLC
 Peoria, IL

File: W:\Jobs\2020\236161\ENGINEERING\236161.out
 Contract: 236161
 Project: 190 FT RT TOWER
 Date and Time: 12/3/2020 10:08:30 AM

Revision: 0
 Site: FULLERS RIDGE- KY
 Engineer: SWG

Section F: POINT LOAD DATA

Structure Azimuth from North:0.00

POINT LOADS

No.	Description	Elev. (ft)	Radius (ft)	Azim. (Deg)	Orient. (Deg)	Vertical Offset (ft)	Tx Line	Comments
1	LIGHTNING ROD	190.00	1.00	0.0	0.0	0.00		
2	CARRIER	185.00	1.00	0.0	0.0	0.00		
3	CARRIER	175.00	1.00	120.0	120.0	0.00		
4	CARRIER	165.00	1.00	240.0	240.0	0.00		
5	CARRIER	135.00	1.00	0.0	0.0	0.00		
6	CARRIER	125.00	1.00	120.0	120.0	0.00		
7	CARRIER	115.00	1.00	240.0	240.0	0.00		

POINT LOADS WIND AREAS AND WEIGHTS

No.	Description	Frontal Bare Area (ft^2)	Lateral Bare Area (ft^2)	Frontal Iced Area (ft^2)	Lateral Iced Area (ft^2)	Weight Bare (Kips)	Weight Iced (Kips)	Gh
1	LIGHTNING ROD	1.00	1.00	2.00	2.00	0.10	0.20	0.85
2	CARRIER	116.00	116.00	303.00	303.00	2.90	9.90	0.85
3	CARRIER	116.00	116.00	303.00	303.00	2.90	9.90	0.85
4	CARRIER	116.00	116.00	303.00	303.00	2.90	9.90	0.85
5	CARRIER	116.00	116.00	303.00	303.00	2.90	9.90	0.85
6	CARRIER	116.00	116.00	303.00	303.00	2.90	9.90	0.85
7	CARRIER	116.00	116.00	303.00	303.00	2.90	9.90	0.85



ENGINEERING SOFTWARE
 TSTower - v 5.8.6 Tower Analysis Program
 (c) 1997-2020 TowerSoft www.TSTower.com



Graduate
 Licensed to: ROHN Products LLC
 Peoria, IL

File: W:\Jobs\2020\236161\ENGINEERING\236161.out
 Contract: 236161
 Project: 190 FT RT TOWER
 Date and Time: 12/3/2020 10:08:30 AM

Revision: 0
 Site: FULLERS RIDGE- KY
 Engineer: SWG

Section H: STRUCTURE DISPLACEMENT DATA
 Load Combination Wind Only - Serviceability

Wind Direction		Maximum displacements					
Node	Elev. (ft)	N-S Disp (in)	W-E Disp (in)	Vert. Disp (in)	N-S Rot (Deg)	W-E Rot (Deg)	Twist (Deg)
84	190.0	8.3	7.8	-0.1	0.42	0.40	-0.04
81	185.0	7.8	7.4	-0.1	0.44	0.42	-0.05
78	180.0	7.4	6.9	-0.1	0.42	0.40	-0.03
75	175.0	6.9	6.5	-0.1	0.44	0.42	-0.05
72	170.0	6.5	6.1	-0.1	0.41	0.39	-0.02
69	165.0	6.0	5.7	-0.1	0.42	0.40	-0.04
66	160.0	5.6	5.2	-0.1	0.39	0.37	-0.02
63	155.0	5.2	4.9	-0.1	0.37	0.35	-0.03
60	150.0	4.8	4.5	-0.1	0.34	0.32	-0.02
57	143.3	4.3	4.1	-0.1	0.32	0.30	-0.03
54	136.7	3.9	3.6	-0.1	0.29	0.28	-0.02
51	130.0	3.5	3.2	-0.1	0.27	0.26	-0.02
48	123.3	3.1	2.9	-0.1	0.25	0.24	-0.01
45	116.7	2.7	2.6	-0.1	0.24	0.22	-0.01
42	110.0	2.4	2.2	-0.1	0.21	0.20	-0.01
39	103.3	2.1	2.0	-0.1	0.21	0.19	-0.01
36	96.7	1.8	1.7	-0.1	0.18	0.17	0.00
33	90.0	1.6	1.5	0.0	0.16	0.15	-0.01
30	80.0	1.2	1.1	0.0	0.13	0.12	-0.01
27	70.0	0.9	0.9	0.0	0.12	0.11	-0.01
24	60.0	0.7	0.6	0.0	0.09	0.09	-0.01
21	50.0	0.5	0.5	0.0	0.09	0.08	0.00
18	40.0	0.3	0.3	0.0	0.06	0.06	0.00
15	30.0	0.2	0.2	0.0	0.05	0.05	0.00
12	20.0	0.1	-0.1	0.0	0.03	0.03	0.00
8	10.0	0.0	0.0	0.0	0.01	-0.01	0.00
3	0.0	0.0	0.0	0.0	0.00	0.00	0.00



TOWER SOFTWARE
 TSTower - v 5.8.6 Tower Analysis Program
 (c) 1997-2020 TowerSoft www.TSTower.com



ROHN
 Graduate
 Licensed to: ROHN Products LLC
 Peoria, IL

File: W:\Jobs\2020\236161\ENGINEERING\236161.out
 Contract: 236161
 Project: 190 FT RT TOWER
 Date and Time: 12/3/2020 10:08:30 AM

Revision: 0
 Site: FULLERS RIDGE- KY
 Engineer: SWG

Section J: ANTENNA DISPLACEMENT DATA
 Load Combination Wind Only - Serviceability

Wind Direction		Maximum displacements						
Ant.	Elev. (ft)	N-S Disp (in)	W-E Disp (in)	Vert.Disp (in)	N-S Rot (Deg)	W-E Rot (Deg)	Twist Tot (Deg)	Allow. (Deg)
1	145.00	4.4	4.2	-0.1	0.32	0.30	-0.03	1.11
2	145.00	4.4	4.2	-0.1	0.32	0.30	-0.03	1.11

File: W:\Jobs\2020\236161\ENGINEERING\236161.out
Contract: 236161
Project: 190 FT RT TOWER
Date and Time: 12/3/2020 10:08:30 AM

Revision: 0
Site: FULLERS RIDGE- KY
Engineer: SWG

Section L: STRENGTH ASSESSMENT SORTED DATA
Load Combination Max Envelope
Wind Direction Maximum

Sec	Pnl	Elev.	MType	Desc.	Len	kl/r	Gov. comp. cap. (Kips)	Gov. tens. cap. (Kips)	Max Compr. (Kips)	Max Tens. (Kips)	Asses. Ratio
		(ft)			(ft)						
8	4	185.00	Leg	PIPE 2.875x0.203	5.00	63.4	57.1	76.5	1.3	1.0	0.02
8	3	180.00	Leg	PIPE 2.875x0.203	5.00	63.4	57.1	76.5	6.4	2.3	0.11
8	2	175.00	Leg	PIPE 2.875x0.203	5.00	63.4	57.1	76.5	9.4	6.1	0.16
8	1	170.00	Leg	PIPE 2.875x0.203	5.00	63.4	57.1	76.5	18.2	13.4	0.32
7	4	165.00	Leg	PIPE 3.500x0.216	5.00	51.7	82.5	100.4	29.2	23.7	0.35
7	3	160.00	Leg	PIPE 3.500x0.216	5.00	51.7	82.5	100.4	42.4	34.3	0.51
7	2	155.00	Leg	PIPE 3.500x0.216	5.00	51.7	82.5	100.4	60.5	51.4	0.73
7	1	150.00	Leg	PIPE 3.500x0.216	5.00	51.7	82.5	100.4	75.6	66.1	0.92
6	3	143.33	Leg	PIPE 4.500x0.337	6.68	54.2	160.1	198.4	92.8	82.7	0.58
6	2	136.67	Leg	PIPE 4.500x0.337	6.68	54.2	160.1	198.4	111.0	98.3	0.69
6	1	130.00	Leg	PIPE 4.500x0.337	6.68	54.2	160.1	198.4	131.5	116.0	0.82
5	3	123.33	Leg	PIPE 5.563x0.375	6.68	43.6	239.3	275.0	153.3	135.0	0.64
5	2	116.67	Leg	PIPE 5.563x0.375	6.68	43.6	239.3	275.0	175.0	154.6	0.73
5	1	110.00	Leg	PIPE 5.563x0.375	6.68	43.6	239.3	275.0	199.0	175.6	0.83
4	3	103.33	Leg	PIPE 6.625x0.432	6.68	36.4	343.5	378.5	221.9	196.9	0.65
4	2	96.67	Leg	PIPE 6.625x0.432	6.68	36.4	343.5	378.5	244.1	217.2	0.71
4	1	90.00	Leg	PIPE 6.625x0.432	6.68	36.4	343.5	378.5	264.3	236.1	0.77
3	3	80.00	Leg	PIPE 8.625x0.375	10.03	41.2	386.3	437.4	285.8	255.5	0.74
3	2	70.00	Leg	PIPE 8.625x0.375	10.03	41.2	386.3	437.4	309.8	276.9	0.80
3	1	60.00	Leg	PIPE 8.625x0.375	10.03	41.2	386.3	437.4	330.3	295.0	0.86
2	3	50.00	Leg	PIPE 8.625x0.500	10.03	41.8	505.4	574.2	351.9	313.7	0.70
2	2	40.00	Leg	PIPE 8.625x0.500	10.03	41.8	505.4	574.2	371.3	330.2	0.73
2	1	30.00	Leg	PIPE 8.625x0.500	10.03	41.8	505.4	574.2	391.5	347.2	0.77
1	3	20.00	Leg	PIPE 8.625x0.500	10.03	41.8	505.4	574.2	410.2	362.7	0.81
1	2	10.00	Leg	PIPE 8.625x0.500	10.03	41.8	505.4	574.2	429.9	378.5	0.85
1	1	0.00	Leg	PIPE 8.625x0.500	10.03	41.8	505.4	574.2	440.0	385.5	0.87
8	4	185.00	Diag	L1 3/4x1 3/4x3/16	8.40	134.0	7.8	10.7	2.0	2.2	0.26
8	3	180.00	Diag	L1 3/4x1 3/4x3/16	8.41	134.1	7.8	10.7	2.8	2.7	0.36
8	2	175.00	Diag	L1 3/4x1 3/4x3/16	8.42	134.3	7.8	10.7	3.1	3.1	0.39
8	1	170.00	Diag	L1 3/4x1 3/4x3/16	8.43	134.5	7.7	10.7	5.4	5.3	0.70
7	4	165.00	Diag	L2x2x3/16	8.44	117.2	11.7	11.8	5.6	5.7	0.48
7	3	160.00	Diag	L2x2x3/16	8.46	117.4	11.6	11.8	7.6	7.5	0.66
7	2	155.00	Diag	L2x2x3/16	8.47	117.5	11.6	11.8	7.9	8.0	0.68
7	1	150.00	Diag	L2x2x3/16	8.49	117.7	11.6	11.8	8.4	8.3	0.73
6	3	143.33	Diag	L2 1/2x2 1/2x1/4	9.82	113.6	15.2	15.2	7.3	6.9	0.48
6	2	136.67	Diag	L2 1/2x2 1/2x1/4	10.34	118.7	15.2	15.2	9.3	9.1	0.61
6	1	130.00	Diag	L2 1/2x2 1/2x1/4	10.88	125.2	15.2	15.2	10.4	10.4	0.68
5	3	123.33	Diag	L3x3x1/4	11.44	111.2	15.2	15.2	11.0	10.9	0.73
5	2	116.67	Diag	L3x3x1/4	12.00	115.8	15.2	15.2	12.2	12.2	0.80
5	1	110.00	Diag	L3x3x1/4	12.59	120.4	15.2	15.2	13.0	12.9	0.86
4	3	103.33	Diag	L3x3x1/4	13.19	125.8	15.2	15.2	12.8	12.8	0.84
4	2	96.67	Diag	L3x3x1/4	13.81	132.3	15.2	15.2	12.6	12.6	0.83
4	1	90.00	Diag	L3x3x1/4	14.44	138.8	15.2	15.2	12.4	12.4	0.82
3	3	80.00	Diag	L3 1/2x3 1/2x1/4	17.07	135.9	20.7	30.4	11.5	11.2	0.56
3	2	70.00	Diag	L3 1/2x3 1/2x1/4	18.17	143.4	18.6	30.4	11.1	11.3	0.60
3	1	60.00	Diag	L3 1/2x3 1/2x1/4	19.30	151.0	16.7	30.4	11.3	11.1	0.68
2	3	50.00	Diag	L3 1/2x3 1/2x1/4	20.45	158.8	15.1	30.4	11.2	11.4	0.74
2	2	40.00	Diag	L3 1/2x3 1/2x1/4	21.62	166.7	13.7	30.4	11.6	11.4	0.85
2	1	30.00	Diag	L3 1/2x3 1/2x1/4	22.81	174.7	12.5	30.4	11.7	11.8	0.93
1	3	20.00	Diag	L4x4x3/8	24.02	163.1	24.3	30.4	12.1	11.9	0.50
1	2	10.00	Diag	L4x4x3/8	25.23	170.3	22.3	30.4	12.3	12.4	0.55
1	1	0.00	Diag	L4x4x3/8	16.08	181.3	19.7	30.4	15.4	15.4	0.78
8	4	185.00	Horiz	L1 3/4x1 3/4x3/16	6.75	216.3	3.0	10.7	1.7	1.6	0.56



TSTower - v 5.8.6 Tower Analysis Program
(c) 1997-2020 TowerSoft www.TSTower.com



Peoria, IL
Licensed to: ROHN Products LLC

File: W:\Jobs\2020\236161\ENGINEERING\236161.out
Contract: 236161
Project: 190 FT RT TOWER
Date and Time: 12/3/2020 10:08:30 AM

Revision: 0
Site: FULLERS RIDGE- KY
Engineer: SWG

1	L	0.00	Horiz	L3 1/2x3 1/2x1/4	11.92	167.2	13.7	30.4	12.2	12.0	0.89
1	1	0.00	PlanH1	L3x3x3/16	11.92	242.3	4.2	14.7	0.1	0.1	0.02

File: W:\Jobs\2020\236161\ENGINEERING\236161.out
Contract: 236161
Project: 190 FT RT TOWER
Date and Time: 12/3/2020 10:08:30 AM

Revision: 0
Site: FULLERS RIDGE- KY
Engineer: SWG

Section M: SECTION PROPERTIES DATA

Sec	Pan	Memb. Type	Steel Grade	Conn. Type	Bolts	Bolt Size (in)	Bolt Grade	End Dist. (in)	Gusset Thick. (in)	kl/r	Comp. (Kips)	Tens. Cap. (Kips)	Bolt Cap. (Kips)	Bear. Cap. (Kips)	Block Shear (Kips)
8	4	Leg	A500 gr.CS	Tension	4	0.750	A325X	1.125	N/A	63.4	57.1	76.5	121.7T	N/A	N/A
8	4	Diag	A529 gr.50	Bolted	1	0.625	A325X	1.500	0.250	134.0	7.8	17.4	15.2S	14.7	10.7
8	4	Horiz	A529 gr.50	Bolted	1	0.625	A325X	1.500	0.250	216.3	3.0	17.4	15.2S	14.7	10.7
8	3	Leg	A500 gr.CS	Tension	4	0.750	A325X	1.125	N/A	63.4	57.1	76.5	121.7T	N/A	N/A
8	3	Diag	A529 gr.50	Bolted	1	0.625	A325X	1.500	0.250	134.1	7.8	17.4	15.2S	14.7	10.7
8	2	Leg	A500 gr.CS	Tension	4	0.750	A325X	1.125	N/A	63.4	57.1	76.5	121.7T	N/A	N/A
8	2	Diag	A529 gr.50	Bolted	1	0.625	A325X	1.500	0.250	134.3	7.8	17.4	15.2S	14.7	10.7
8	1	Leg	A500 gr.CS	Tension	4	0.750	A325X	1.125	N/A	63.4	57.1	76.5	121.7T	N/A	N/A
8	1	Diag	A529 gr.50	Bolted	1	0.625	A325X	1.500	0.250	134.5	7.7	17.4	15.2S	14.7	10.7
7	4	Leg	A500 gr.CS	Tension	5	0.875	A325X	1.313	N/A	51.7	82.5	100.4	209.9T	N/A	N/A
7	4	Diag	A529 gr.50	Bolted	1	0.625	A325X	1.500	0.250	117.2	11.7	20.7	15.2S	14.7	11.8
7	3	Leg	A500 gr.CS	Tension	5	0.875	A325X	1.313	N/A	51.7	82.5	100.4	209.9T	N/A	N/A
7	3	Diag	A529 gr.50	Bolted	1	0.625	A325X	1.500	0.250	117.4	11.6	20.7	15.2S	14.7	11.8
7	2	Leg	A500 gr.CS	Tension	5	0.875	A325X	1.313	N/A	51.7	82.5	100.4	209.9T	N/A	N/A
7	2	Diag	A529 gr.50	Bolted	1	0.625	A325X	1.500	0.250	117.5	11.6	20.7	15.2S	14.7	11.8
7	1	Leg	A500 gr.CS	Tension	5	0.875	A325X	1.313	N/A	51.7	82.5	100.4	209.9T	N/A	N/A
7	1	Diag	A529 gr.50	Bolted	1	0.625	A325X	1.500	0.250	117.7	11.6	20.7	15.2S	14.7	11.8
6	3	Leg	A500 gr.CS	Tension	5	1.000	A325X	1.500	N/A	54.2	160.1	198.4	275.3T	N/A	N/A
6	3	Diag	A529 gr.50	Bolted	1	0.625	A325X	1.500	0.250	113.6	20.8	36.5	15.2S	19.5	18.7
6	2	Leg	A500 gr.CS	Tension	5	1.000	A325X	1.500	N/A	54.2	160.1	198.4	275.3T	N/A	N/A
6	2	Diag	A529 gr.50	Bolted	1	0.625	A325X	1.500	0.250	118.7	19.1	36.5	15.2S	19.5	18.7
6	1	Leg	A500 gr.CS	Tension	5	1.000	A325X	1.500	N/A	54.2	160.1	198.4	275.3T	N/A	N/A
6	1	Diag	A529 gr.50	Bolted	1	0.625	A325X	1.500	0.250	125.2	17.2	36.5	15.2S	19.5	18.7
5	3	Leg	A500 gr.CS	Tension	6	1.000	A325X	1.500	N/A	43.6	239.3	275.0	330.3T	N/A	N/A
5	3	Diag	A529 gr.50	Bolted	1	0.625	A325X	1.500	0.250	111.2	26.2	45.6	15.2S	19.5	23.2
5	2	Leg	A500 gr.CS	Tension	6	1.000	A325X	1.500	N/A	43.6	239.3	275.0	330.3T	N/A	N/A
5	2	Diag	A529 gr.50	Bolted	1	0.625	A325X	1.500	0.250	115.8	24.3	45.6	15.2S	19.5	23.2
5	1	Leg	A500 gr.CS	Tension	6	1.000	A325X	1.500	N/A	43.6	239.3	275.0	330.3T	N/A	N/A
5	1	Diag	A529 gr.50	Bolted	1	0.625	A325X	1.500	0.250	120.4	22.4	45.6	15.2S	19.5	23.2
4	3	Leg	A500 gr.CS	Tension	6	1.500	A325X	2.250	N/A	36.4	343.5	378.5	765.3T	N/A	N/A
4	3	Diag	A529 gr.50	Bolted	1	0.625	A325X	1.500	0.250	125.8	20.6	45.6	15.2S	19.5	23.2
4	2	Leg	A500 gr.CS	Tension	6	1.500	A325X	2.250	N/A	36.4	343.5	378.5	765.3T	N/A	N/A
4	2	Diag	A529 gr.50	Bolted	1	0.625	A325X	1.500	0.250	132.3	18.6	45.6	15.2S	19.5	23.2
4	1	Leg	A500 gr.CS	Tension	6	1.500	A325X	2.250	N/A	36.4	343.5	378.5	765.3T	N/A	N/A
4	1	Diag	A529 gr.50	Bolted	1	0.625	A325X	1.500	0.250	138.8	16.9	45.6	15.2S	19.5	23.2
3	3	Leg	A500 gr.CS	Tension	6	1.500	A325X	2.250	N/A	41.2	386.3	437.4	765.3T	N/A	N/A
3	3	Diag	A529 gr.50	Bolted	2	0.625	A325X	1.125	0.375	135.9	20.7	54.8	30.4S	34.1	34.2
3	2	Leg	A500 gr.CS	Tension	6	1.500	A325X	2.250	N/A	41.2	386.3	437.4	765.3T	N/A	N/A
3	2	Diag	A529 gr.50	Bolted	2	0.625	A325X	1.125	0.375	143.4	18.6	54.8	30.4S	34.1	34.2
3	1	Leg	A500 gr.CS	Tension	6	1.500	A325X	2.250	N/A	41.2	386.3	437.4	765.3T	N/A	N/A
3	1	Diag	A529 gr.50	Bolted	2	0.625	A325X	1.125	0.375	151.0	16.7	54.8	30.4S	34.1	34.2
2	3	Leg	A500 gr.CS	Tension	6	1.500	A325X	2.250	N/A	41.8	505.4	574.2	765.3T	N/A	N/A
2	3	Diag	A529 gr.50	Bolted	2	0.625	A325X	1.125	0.375	158.8	15.1	54.8	30.4S	34.1	34.2
2	2	Leg	A500 gr.CS	Tension	6	1.500	A325X	2.250	N/A	41.8	505.4	574.2	765.3T	N/A	N/A
2	2	Diag	A529 gr.50	Bolted	2	0.625	A325X	1.125	0.375	166.7	13.7	54.8	30.4S	34.1	34.2
2	1	Leg	A500 gr.CS	Tension	6	1.500	A325X	2.250	N/A	41.8	505.4	574.2	765.3T	N/A	N/A
2	1	Diag	A529 gr.50	Bolted	2	0.625	A325X	1.125	0.375	174.7	12.5	54.8	30.4S	34.1	34.2
1	3	Leg	A500 gr.CS	Tension	6	1.500	A325X	2.250	N/A	41.8	505.4	574.2	765.3T	N/A	N/A
1	3	Diag	A529 gr.50	Bolted	2	0.625	A325X	1.125	0.375	163.1	24.3	94.1	30.4S	51.2	51.2
1	2	Leg	A500 gr.CS	Tension	6	1.500	A325X	2.250	N/A	41.8	505.4	574.2	765.3T	N/A	N/A
1	2	Diag	A529 gr.50	Bolted	2	0.625	A325X	1.125	0.375	170.3	22.3	94.1	30.4S	51.2	51.2



ENGINEERING SOFTWARE
 TSTower - v 5.8.6 Tower Analysis Program
 (c) 1997-2020 TowerSoft www.TSTower.com



Graduate
 Licensed to: ROHN Products LLC
 Peoria, IL

File: W:\Jobs\2020\236161\ENGINEERING\236161.out
 Contract: 236161
 Project: 190 FT RT TOWER
 Date and Time: 12/3/2020 10:08:30 AM

Revision: 0
 Site: FULLERS RIDGE- KY
 Engineer: SWG

1	1	Leg	A500	gr.CS	Tension	6	1.500	A325X	2.250	N/A	41.8	505.4	574.2	765.3T	N/A	N/A
1	1	Diag	A529	gr.50	Bolted	2	0.625	A325X	1.125	0.375	181.3	19.7	94.1	30.4S	51.2	51.2
1	1	Horiz	A529	gr.50	Bolted	2	0.625	A325X	1.125	0.375	167.2	13.7	54.8	30.4S	34.1	34.2
1	1	PlanH1	A529	gr.50	Bolted	1	0.625	A325X	1.500	0.250	242.3	4.2	34.6	15.2S	14.7	17.5



TSTower - v 5.8.6 Tower Analysis Program
(c) 1997-2020 TowerSoft www.TSTower.com



Graduate
Licensed to: ROHN Products LLC
Peoria, IL

File: W:\Jobs\2020\236161\ENGINEERING\236161.out
Contract: 236161
Project: 190 FT RT TOWER
Date and Time: 12/3/2020 10:08:30 AM

Revision: 0
Site: FULLERS RIDGE- KY
Engineer: SWG

Section N: LEG REACTION DATA

Load Combination	Max Envelope				
Wind Direction	Maximum				
	Force-Y Download (Kips)	Force-Y Uplift (Kips)	Shear-X (Kips)	Shear-Z (Kips)	Max Shear (Kips)
	456.65	399.72			53.09



TSTower - v 5.8.6 Tower Analysis Program
 (c) 1997-2020 TowerSoft www.TSTower.com



ROHN
 Graduate
 Licensed to: ROHN Products LLC
 Peoria, IL

File: W:\Jobs\2020\236161\ENGINEERING\236161.out
 Contract: 236161
 Project: 190 FT RT TOWER
 Date and Time: 12/3/2020 10:08:30 AM

Revision: 0
 Site: FULLERS RIDGE- KY
 Engineer: SWG

Section O: TOWER FOUNDATION DATA

Load Combination Max Envelope
 Wind Direction Maximum

Axial Load (Kips)	Shear Load-X (Kips)	Shear Load-Z (Kips)	Total Shear (Kips)	Moment-X (Kipsft)	Moment-Y (Kipsft)	Moment-Z (Kipsft)	Total Moment (Kipsft)
70.81	-87.12	-0.02	87.12	-2.46	-12.28	9437.23	9437.23
53.11	-87.13	-0.02	87.13	-1.84	-12.28	9436.77	9436.77

Customer: EAST KENTUCKY NETWORK
 Project: 190 FT RT TOWER
 Site: FULLERS RIDGE- KY
 Engr. File: 236161
 Build Code: ANSI/TIA-222-H-2016



Mat Foundation

ver.2.2.15

Design Parameters

Description	Load Case					
	1	2	3	4	5	Service
Total Moment, ft-kips	9,437.23	9,436.77	1,648.31	341.79	341.03	3,181.12
Total Shear, kips	87.12	87.13	14.16	2.46	2.46	29.37
Total Tower Wt, kips	70.81	53.11	209.37	70.77	53.08	58.98
Max. Uplift, kips	393.80	399.72	4.18	.00	.00	121.01
Shear, kips	47.63	48.07	3.01	15.15	15.15	15.15
Max Download, kips	456.65	450.73	145.42	39.22	33.30	165.63
Shear	53.09	52.66	13.75	3.29	2.85	18.83
Soil L.F.	1.20	0.90	1.20	1.20	0.90	1.00
Concrete L.F.	1.20	0.90	1.20	1.20	0.90	1.00

Foundation	
Ht. AGL, ft	0.50
Depth, ft.	6.00
Tower	
Face Width, ft	25.16
Offset, in	48.00
Soil	
Blow Count	N/A
Inplace Unit Wt, pcf	110.00
Submerged Unit Wt, pcf	60.00
Friction Angle, ϕ , deg.	30.00
Cohesion, ksf	N/A
Uplift Angle, deg.	30.00
Water Depth, ft	None
Ult Bearing Capacity, ksf	16.00

Mat	
Thickness, ft	2.00
Width, ft	33.00
EA, in	18.00
Batter, in/ft	0.00

Pier	
Height, ft	4.50
Diameter, ft	3.50
No. Piers	3
Shape	Round

Anchor Bolts	
Diameter, in	1.5000
No.	6
Length, in	74.00
Bolt Circle, in	20.00
Projection, in	9.00

Pocket	
Diameter, in	N/A
Thickness, ft	N/A

Concrete	
28 Day Strength, ksi	4.50
Dry Unit Wt, pcf	150.00
Wet Unit Wt, pcf	88.00

Rebar Fy	
Vertical, ksi	60.00
Circular, ksi	60.00
Horizontal, ksi	60.00

Results

ϕM_N - Parallel Axis 12,251.89 ft-kips
 ϕM_N - Diagonal Axis 13,490.03 ft-kips
 Moment - Interaction Ratio 0.836
 ϕV_N - Lateral Load 205.93 kips
 Lateral Load - Interaction Ratio 0.423

Final Mat Dimension : 33.00 x 33.00 x 2.00 ft. thick w/ (3) 3.50 ft. Dia. Piers

Final Pocket Dimension : Pockets not required

Total Volume of Concrete : 85.5 yd³

Designed By: SWG
 Date: 03 Dec,20 @ 10:10 AM

Checked By: H/A
 Date: 12/13/20

Customer: EAST KENTUCKY NETWORK
 Project: 190 FT RT TOWER
 Site: FULLERS RIDGE- KY
 Engr. File: 236161
 Build Code: ANSI/TIA-222-H-2016



Mat Foundation

ver.2.2.15

OTM Capacity

Controlling Load Case: 2 [Wind w/Min. Dead Load]
 Foundation Width = 33.00 ft
 $M_U = 10,242.7$ ft-kips

	ϕM_N , ft-kips	x, ft	N	σ_{UR}
Parallel	12,251.9	3.300	0.100	9.92
Diagonal	13,490.0	10.436	0.224	9.92

$\phi M_N = 12,251.89$ ft-kips IRatio = 0.836
 $\phi V_N = 205.93$ kips IRatio = 0.423

Mat Design

$\gamma_c = 123.33$ pcf

Exterior Slab	x, ft	N	σ_R , ksf	P_s , kips	P_{su} , kips	Moment, ft-kips/ft		Shear, kips/ft	
						DownLoad Side	Uplift Side	DownLoad Side	Uplift Side
Parallel	7.977	0.242	3.06	26.07	0.00	21.39	11.19	10.13	4.52
Diagonal	16.234	0.348	3.06	26.07	0.00	88.73	39.79	19.43	8.73

Interior Slab	Moment, ft-kips/ft		Shear, kips/ft		Soil Pressure Termination
	DownLoad Side	Uplift Side	DownLoad Side	Uplift Side	
	22.56	69.80	5.77	8.27	6.07

Punching Shear	Download			Uplift			Description
	Interior	Edge	Corner	Interior	Edge	Corner	
b_o , ft	18.74	17.21	13.84	16.08	15.88	13.18	2-Way Shear
V_{su} , psi	122.62	140.05	183.82	124.37	130.94	167.98	
ϕV_c , psi	228.08	228.08	228.08	228.08	228.08	228.08	
IR	0.54	0.61	0.81	0.55	0.57	0.74	
M_{ult} , ft-kips	143.3			129.8			Moment transfer to slab
B_e , ft	8.7			8.3			
M_u , ft-kips/ft	16.5			15.6			
Edge Distances: a = 5.97 ft. b = 3.92 ft. c = 5.24 ft.							

Summary	Max. Value	Utilization
Slab Moment, ft-kips/ft	88.73	0.965
Slab Shear, kips/ft	19.43	0.747
Punching Shear, psi	183.82	0.806
Soil Bearing Required, σ_{UR} , ksf	4.08	0.255

Mat Reinforcement	
Min. Steel Area (Strength)	.912 in ² /ft.
Min. Steel Area (Temperature)	.259 in ² /ft.
Steel Strain Actual	0.016
Minimum Steel Strain Required	0.005

40 - #8 Horizontal bars equally spaced @10.00 in., each way, top and bottom, total of 160, $A_s = 0.952$ in²/ft

Designed By: SWG
 Date: 03 Dec,20 @ 10:10 AM

Checked By: HA
 Date: 12/3/20

Customer: EAST KENTUCKY NETWORK
 Project: 190 FT RT TOWER
 Site: FULLERS RIDGE- KY
 Engr. File: 236161
 Build Code: ANSI/TIA-222-H-2016



Mat Foundation

ver.2.2.15

Pier Design

Controlling Load Case: 2 [Wind w/Min. Dead Load]

C = 450.73 kips	Vc = 52.66 kips	Mc = 236.97 ft-kips
T = 399.72 kips	Vt = 48.07 kips	Mt = 216.32 ft-kips
Fy = 60.00 ksi	Fyt = 60.00 ksi	L.F. = 1.00
H = 42.00 in.	Ds = 33.00 in.	F'c = 4.50 ksi
U = 1.00	Irs = Round	

*** NOTE: Pier cross section is Round ***

SUMMARY OF ANALYSIS

Minimum area of steel required	= 13.862 in ²	(Rhomin = 0.0100)
Area of steel provided.	= 13.991 in ²	(Rhoactual = 0.0101)
Maximum steel area limit	= 110.836 in ²	(Rhomax = 0.0800)

(14) #9 Vertical Bars equally spaced w/ #4 Circular Ties @ 6" on center.

CIRCULAR TIE DATA

Size	Spacing
3	6.3
4	11.4
5	12.0
6	12.0

Use spacing shown or maximum tie spacing specified in ACI 318, Section 7.10.5 for compression reinforcement, whichever is less.

DEVELOPMENT LENGTH MODIFIERS FOR BAR DEVELOPMENT

Modifier for tension development = 1.000
 Modifier for compression development = 0.149

REQUIRED Ld = MODIFIER * BASIC Ld * ACI 318 MODIFIERS, (12 in. min.)

Designed By: SWG
 Date: 03 Dec,20 @ 10:10 AM

Checked By: HA
 Date: 12/3/20

Exhibit 6



Mail Processing Center
Federal Aviation Administration
Southwest Regional Office
Obstruction Evaluation Group
10101 Hillwood Parkway
Fort Worth, TX 76177

Aeronautical Study No.
2020-ASO-31494-OE

Issued Date: 12/07/2020

Cindy D. McCarty
East Kentucky Network, LLC
101 Technology Trail
Ivel, KY 41642

**** DETERMINATION OF NO HAZARD TO AIR NAVIGATION ****

The Federal Aviation Administration has conducted an aeronautical study under the provisions of 49 U.S.C., Section 44718 and if applicable Title 14 of the Code of Federal Regulations, part 77, concerning:

Structure:	Antenna Tower Fullers Ridge
Location:	Louisa, KY
Latitude:	38-09-32.46N NAD 83
Longitude:	82-39-53.24W
Heights:	1012 feet site elevation (SE) 199 feet above ground level (AGL) 1211 feet above mean sea level (AMSL)

This aeronautical study revealed that the structure does not exceed obstruction standards and would not be a hazard to air navigation provided the following condition(s), if any, is(are) met:

Based on this evaluation, marking and lighting are not necessary for aviation safety. However, if marking/lighting are accomplished on a voluntary basis, we recommend it be installed in accordance with FAA Advisory circular 70/7460-1 M.

This determination expires on 06/07/2022 unless:

- (a) the construction is started (not necessarily completed) and FAA Form 7460-2, Notice of Actual Construction or Alteration, is received by this office.
- (b) extended, revised, or terminated by the issuing office.
- (c) the construction is subject to the licensing authority of the Federal Communications Commission (FCC) and an application for a construction permit has been filed, as required by the FCC, within 6 months of the date of this determination. In such case, the determination expires on the date prescribed by the FCC for completion of construction, or the date the FCC denies the application.

NOTE: REQUEST FOR EXTENSION OF THE EFFECTIVE PERIOD OF THIS DETERMINATION MUST BE E-FILED AT LEAST 15 DAYS PRIOR TO THE EXPIRATION DATE. AFTER RE-EVALUATION OF CURRENT OPERATIONS IN THE AREA OF THE STRUCTURE TO DETERMINE THAT NO SIGNIFICANT AERONAUTICAL CHANGES HAVE OCCURRED, YOUR DETERMINATION MAY BE ELIGIBLE FOR ONE EXTENSION OF THE EFFECTIVE PERIOD.

This determination is based, in part, on the foregoing description which includes specific coordinates, heights, frequency(ies) and power. Any changes in coordinates, heights, and frequencies or use of greater power, except those frequencies specified in the Colo Void Clause Coalition; Antenna System Co-Location; Voluntary Best Practices, effective 21 Nov 2007, will void this determination. Any future construction or alteration, including increase to heights, power, or the addition of other transmitters, requires separate notice to the FAA. This determination includes all previously filed frequencies and power for this structure.

If construction or alteration is dismantled or destroyed, you must submit notice to the FAA within 5 days after the construction or alteration is dismantled or destroyed.

This determination does include temporary construction equipment such as cranes, derricks, etc., which may be used during actual construction of the structure. However, this equipment shall not exceed the overall heights as indicated above. Equipment which has a height greater than the studied structure requires separate notice to the FAA.

This determination concerns the effect of this structure on the safe and efficient use of navigable airspace by aircraft and does not relieve the sponsor of compliance responsibilities relating to any law, ordinance, or regulation of any Federal, State, or local government body.

A copy of this determination will be forwarded to the Federal Communications Commission (FCC) because the structure is subject to their licensing authority.

If we can be of further assistance, please contact our office at (817) 222-5928, or chris.smith@faa.gov. On any future correspondence concerning this matter, please refer to Aeronautical Study Number 2020-ASO-31494-OE.

Signature Control No: 453995067-458622312
Chris Smith
Specialist

(DNE)

Attachment(s)
Frequency Data
Map(s)

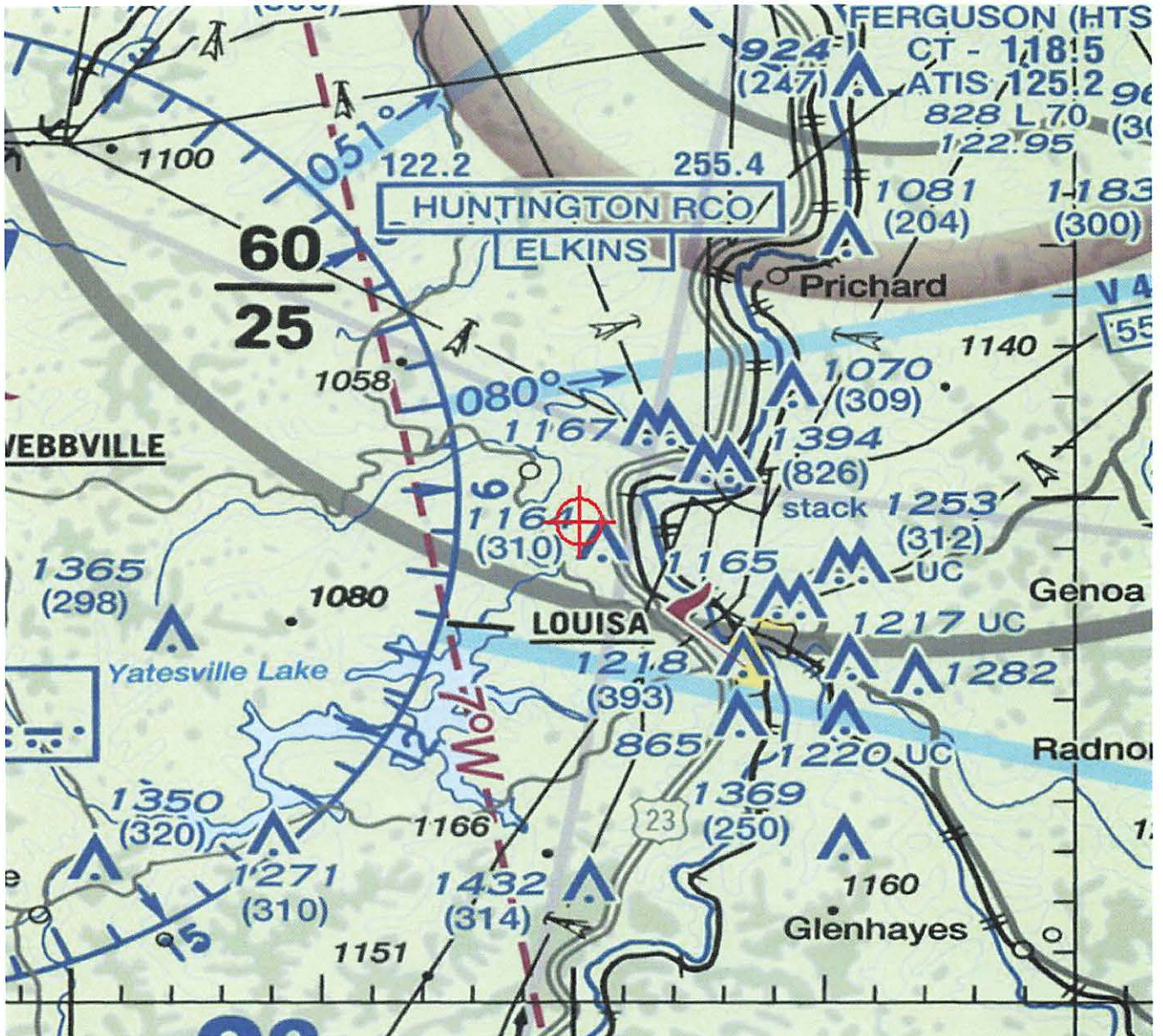
cc: FCC

Frequency Data for ASN 2020-ASO-31494-OE

LOW FREQUENCY	HIGH FREQUENCY	FREQUENCY UNIT	ERP	ERP UNIT
6	7	GHz	55	dBW
6	7	GHz	42	dBW
10	11.7	GHz	55	dBW
10	11.7	GHz	42	dBW
17.7	19.7	GHz	55	dBW
17.7	19.7	GHz	42	dBW
21.2	23.6	GHz	55	dBW
21.2	23.6	GHz	42	dBW
614	698	MHz	1000	W
614	698	MHz	2000	W
698	806	MHz	1000	W
806	901	MHz	500	W
806	824	MHz	500	W
824	849	MHz	500	W
851	866	MHz	500	W
869	894	MHz	500	W
896	901	MHz	500	W
901	902	MHz	7	W
929	932	MHz	3500	W
930	931	MHz	3500	W
931	932	MHz	3500	W
932	932.5	MHz	17	dBW
935	940	MHz	1000	W
940	941	MHz	3500	W
1670	1675	MHz	500	W
1710	1755	MHz	500	W
1850	1910	MHz	1640	W
1850	1990	MHz	1640	W
1930	1990	MHz	1640	W
1990	2025	MHz	500	W
2110	2200	MHz	500	W
2305	2360	MHz	2000	W
2305	2310	MHz	2000	W
2345	2360	MHz	2000	W
2496	2690	MHz	500	W

TOPO Map for ASN 2020-ASO-31494-OE







APPLICATION FOR PERMIT TO CONSTRUCT OR ALTER A STRUCTURE

JURISDICTION

602 KAR 50:030

Section 1. The commission has zoning jurisdiction over that airspace over and around the public use and military airports within the Commonwealth which lies above the imaginary surface that extends outward and upward at one (1) of the following slopes:

- (1) 100 to one (1) for a horizontal distance of 20,000 feet from the nearest point of the nearest runway of each public use airport and military airport with at least one (1) runway 3,200 feet or more in length; or
- (2) fifty (50) to one (1) for a horizontal distance of 10,000 feet from the nearest point of the nearest runway of each public use and military airport with its longest runway less than 3,200 feet in length.

Section 2. The commission has zoning jurisdiction over the use of land and structures within public use airports within the state.

Section 3. The commission has jurisdiction from the ground upward within the limits of the primary and approach surfaces of each public use airport and military airport as depicted on airport zoning maps approved by the Kentucky Airport Zoning Commission.

Section 4. The Commission has jurisdiction over the airspace of the Commonwealth that exceeds 200 feet in height above the ground.

Section 5. The owner or person who has control over a structure which penetrates or will penetrate the airspace over which the Commission has Jurisdiction shall apply for a permit from the Commission in accordance with 602 KAR 50:090.

INSTRUCTIONS

1. "Alteration" means to increase or decrease the height of a structure or change the obstruction marking and lighting.
2. "Applicant" means the person who will own or have control over the completed structure.
3. "Certification by Applicant" shall be made by the individual who will own or control the completed structure; or a partner in a partnership; or the president or authorized officer of a corporation company, or association; or the authorized official of a body politic; or the legally designated representative of a trustee, receiver, or assignee.
4. Prepare the application and forward to the Kentucky Airport Zoning Commission, 421 Buttermilk Pike, Covington, KY 41017. For questions, telephone 859-341-2700.
5. The statutes applicable to the Kentucky Airport Commission are KRS 183.861 to 183.990 and the administrative regulations are 602 KAR Chapter 50.
6. When applicable, attach the following appendices to the application:

Appendix A. A 7.5 minute quadrangle topographical map prepared by the U.S. Geological Survey and the Kentucky Geological Survey with the exact location of the structure which is the subject of the application indicated thereon. (*The 7.5 minute quadrangle map may be obtained from the Kentucky Geological Survey, Department of Mines and Minerals, Lexington, KY 40506.*)

Appendix B. For structures on or very near to property of a public use airport, a copy of the airport layout drawing (ALP) with the exact location of the structure which is the subject of this application indicated thereon. (*The ALP may be obtained from the Chairperson of the local airport board or the Kentucky Airport Zoning Commission.*)

Appendix C. Copies of Federal Aviation Administration Applications (*FFA Form 7460-1*) or any orders issued by the manager, Air Traffic Division, FAA regional office.

Appendix D. If the applicant has indicated in item number 7 of the application that the structure will not be marked or lighted in accordance with the regulations of the Commission, the applicant shall attach a written request for a determination by the commission that the marking and lighting are not necessary. The applicant shall specifically state the reasons that the absence of marking and lighting will not impair the safety of air navigation.

Appendix E. The overall height in feet of the overhead transmission line or static wire above ground level or mean water level with span length 1,000 feet and over shall be depicted on a blueprint profile map.

PENALTIES

1. Persons failing to comply with the Airport Zoning Commission statutes and regulations are liable for a fine or imprisonment as set forth in KRS 183.990(3).
2. Applicants are cautioned: Noncompliance with Federal Aviation Administration Regulations may provide for further penalties.



KENTUCKY TRANSPORTATION CABINET
KENTUCKY AIRPORT ZONING COMMISSION

TC 55-2
Rev. 05/2017
Page 2 of 2

APPLICATION FOR PERMIT TO CONSTRUCT OR ALTER A STRUCTURE

APPLICANT (name) East Kentucky Network, LLC		PHONE 606-339-1006	FAX 606-339-1363	KY AERONAUTICAL STUDY #	
ADDRESS (street) 101 Technology Trail		CITY Ivel		STATE KY	ZIP 41642
APPLICANT'S REPRESENTATIVE (name) Cindy McCarty		PHONE 606-339-1006	FAX 606-339-1363		
ADDRESS (street) 101 Technology Trail		CITY Ivel		STATE KY	ZIP 41642
APPLICATION FOR <input checked="" type="checkbox"/> New Construction <input type="checkbox"/> Alteration <input type="checkbox"/> Existing				WORK SCHEDULE	
DURATION <input type="checkbox"/> Permanent <input type="checkbox"/> Temporary (months days)				Start 1/1/2021 End 1/31/2021	
TYPE <input type="checkbox"/> Crane <input type="checkbox"/> Building <input checked="" type="checkbox"/> Antenna Tower <input type="checkbox"/> Power Line <input type="checkbox"/> Water Tank <input type="checkbox"/> Landfill <input type="checkbox"/> Other		MARKING/PAINTING/LIGHTING PREFERRED <input type="checkbox"/> Red Lights & Paint <input checked="" type="checkbox"/> White- medium intensity <input type="checkbox"/> White- high intensity <input type="checkbox"/> Dual- red & medium intensity white <input type="checkbox"/> Dual- red & high intensity white <input type="checkbox"/> Other			
LATITUDE 38°09'32.46"		LONGITUDE 82°39'53.24"		DATUM <input checked="" type="checkbox"/> NAD83 <input type="checkbox"/> NAD27 <input type="checkbox"/> Other	
NEAREST KENTUCKY City Louisa County Lawrence		NEAREST KENTUCKY PUBLIC USE OR MILITARY AIRPORT Ashland Regional Airport			
SITE ELEVATION (AMSL, feet) 1012		TOTAL STRUCTURE HEIGHT (AGL, feet) 199		CURRENT (FAA aeronautical study #) 2020-ASO-31494-OE	
OVERALL HEIGHT (site elevation plus total structure height, feet) 1211				PREVIOUS (FAA aeronautical study #)	
DISTANCE (from nearest Kentucky public use or Military airport to structure) 24.0 nm				PREVIOUS (KY aeronautical study #)	
DIRECTION (from nearest Kentucky public use or Military airport to structure) SW					
DESCRIPTION OF LOCATION (Attach USGS 7.5 minute quadrangle map or an airport layout drawing with the precise site marked and any certified survey.) Located along Fuller Ridge Road (Lawrence County), KY					
DESCRIPTION OF PROPOSAL Replace the existing 190' tower with a new 190' tower with top-mounted antennas (overall height of 199' AGL)					
FAA Form 7460-1 (Has the "Notice of Construction or Alteration" been filed with the Federal Aviation Administration?) <input type="checkbox"/> No <input checked="" type="checkbox"/> Yes, when? 10-15-2020					
CERTIFICATION (I hereby certify that all the above entries, made by me, are true, complete, and correct to the best of my knowledge and belief.)					
PENALTIES (Persons failing to comply with KRS 183.861 to 183.990 and 602 KAR 050 are liable for fines and/or imprisonment as set forth in KRS 183.990(3). Noncompliance with FAA regulations may result in further penalties.)					
NAME Cindy McCarty	TITLE In-House Counsel	SIGNATURE		DATE 10-15-2020	
COMMISSION ACTION		<input type="checkbox"/> Chairperson, KAZC <input type="checkbox"/> Administrator, KAZC			
<input type="checkbox"/> Approved	SIGNATURE		DATE		
<input type="checkbox"/> Disapproved					

Exhibit 7

Driving Directions for Fullers Ridge

Beginning on East Main Street beside the Lawrence County Court House in Louisa, Kentucky travel approximately 200' to the intersection of East Main Street and Vinson Ave. Turn right on Vinson Ave. and drive four tenths of a mile. Turn right onto KY-3. Continue on KY-3 for 3.3 miles and turn right onto Fullers Ridge Road. Drive 2.4 miles and turn left onto a gated gravel road (sign posted). Drive 0.1 miles to the site (sign posted).

Prepared By:

Daryl Bartley

Cell Site Compliance Agent

East Kentucky Network, LLC

d/b/a Appalachian Wireless

(606) 791-0310 (cell)

(606) 339-1369 (fax)

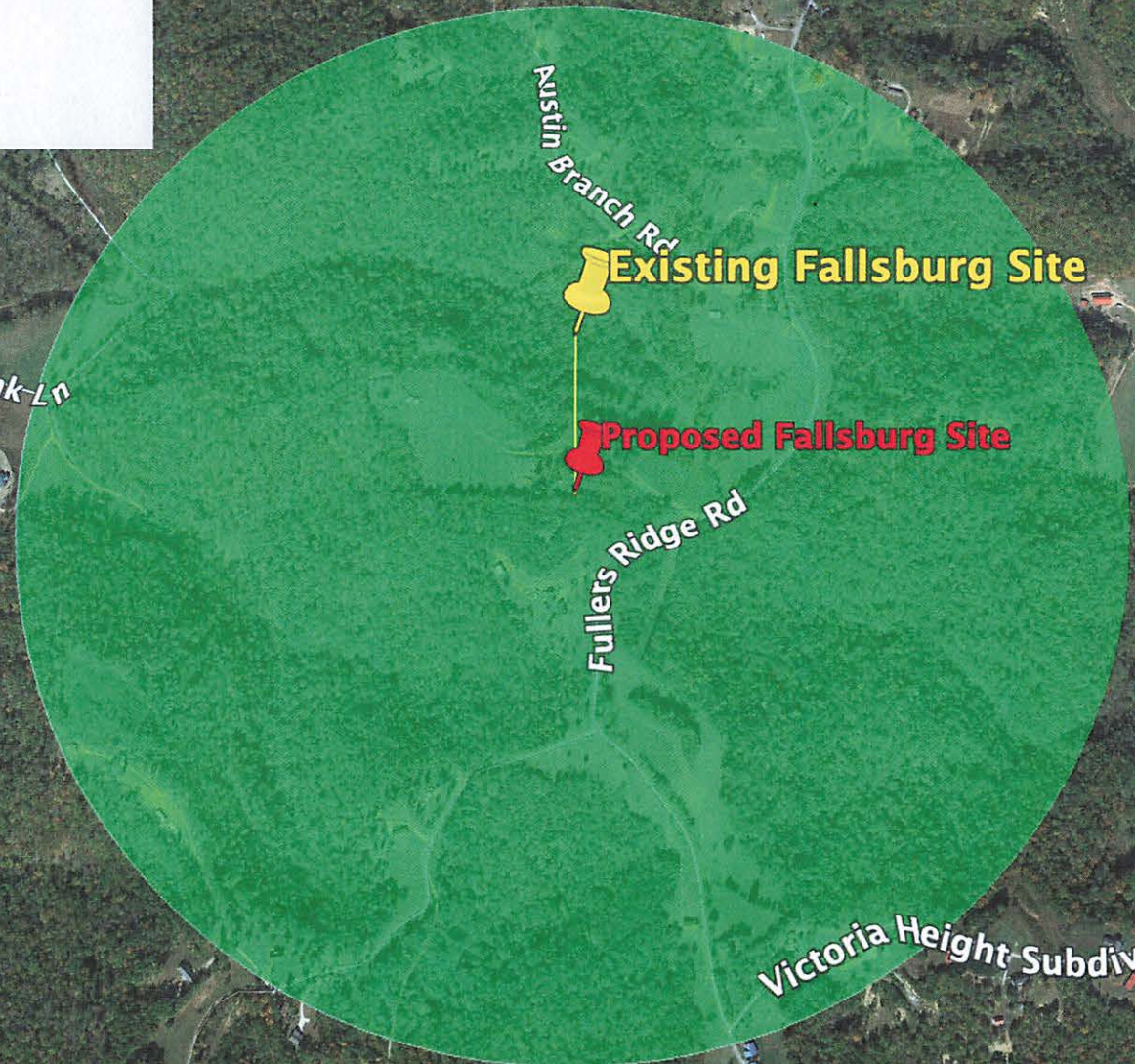
dbartley@ekn.com

Fallsburg Replacement

Location:
2371 Fuller Ridge Road
Louisa, KY 41230

Coordinates:
38° 09' 32.46" N
82° 39' 53.24" W

Legend
1/2 Mile Radius



Google Earth

© 2020 Google



2000 ft

Exhibit 8

ASSIGNMENT OF LEASE AGREEMENTS

THIS ASSIGNMENT OF LEASE AGREEMENTS (the "Agreement") is entered into and effective as of the 28th day of September 2020, (the "Effective Date"), by and between **HIGHLAND COMMUNICATIONS, INC.** ("Assignor"), with a mailing address of 217 Rocky Branch Road, Sandy Hook, Kentucky 41171, and **EAST KENTUCKY NETWORK, LLC D/B/A APPALACHIAN WIRELESS** ("Assignee"), with a mailing address of 101 Technology Trail, Ivel, Kentucky 41642. Assignor and Assignee shall be referred to collectively as the "Parties" or individually as a "Party."

WHEREAS, Assignor is the lessee under that certain Lease Agreement dated May 15, 1987, recorded in the Lawrence County Clerk's Office in Miscellaneous Book 21, Page 679 (hereinafter referred to as the "1987 Lease") and that certain Lease Agreement dated August 5, 1993, recorded in the Lawrence County Clerk's Office in Miscellaneous Book 26, Page 286 (hereinafter referred to as the "1993 Lease"); and

WHEREAS, the property described in the 1987 Lease and in the 1993 Lease is hereinafter referred to collectively as the "Property"; and

WHEREAS, Assignor desires to assign all of its right, title, and interest in the 1987 Lease and in the 1993 Lease to Assignee, and Assignee desires to accept and assume Assignor's obligations under the 1987 Lease and the 1993 Lease; and

NOW THEREFORE, based upon the foregoing premises, which are not mere recitals but an integral part of this Agreement, the mutual promises contained herein, and for other good and valuable consideration, the receipt and sufficiency of which are hereby acknowledged, the Parties, intending to be legally bound, agree as follows:

WITNESSETH

Assignor hereby grants, transfers, conveys, and assigns to Assignee: that certain Lease Agreement dated May 15, 1987, recorded in the Lawrence County Clerk's Office in Miscellaneous Book 21, Page 679; that certain Lease Agreement dated August 5, 1993, recorded in the Lawrence County Clerk's Office in Miscellaneous Book 26, Page 286; and all of Assignor's right, title, and interest in and to the Property referred to in said 1987 Lease and 1993 Lease.

This conveyance is made subject to all of the terms and conditions of the 1987 Lease and the 1993 Lease, Assignee to have and to hold the same with all appurtenances thereunto belonging with covenant of special warranty.

The current term of both the 1987 Lease and the 1993 Lease is for the ten-year period beginning on May 15, 2017, and ending on May 14, 2027, and may be renewed for additional ten-year terms as provided in the leases.

[Remainder of page intentionally left blank.]

IN WITNESS WHEREOF, the Parties have executed this Assignment of Lease Agreements on the date(s) indicated below.

Assignor:

HIGHLAND COMMUNICATIONS, INC.

W A Gillum
By: W.A. Gillum
Its: President
Date: 9-28-2020

COMMONWEALTH OF KENTUCKY
COUNTY OF Floyd :

Subscribed, sworn to and acknowledged before me by W.A. Gillum, the President of Highland Communications, Inc. on the 28th day of September, 2020.

Raina S. Helton
Notary Public
Commission No.: KYNP375

My Commission Expires: 2-6-2024



[Signatures continue on next page.]

Assignee:

EAST KENTUCKY NETWORK, LLC D/B/A
APPALACHIAN WIRELESS

Keith Gabbard
By: Keith Gabbard
Its: President
Date: 10-8-2020

COMMONWEALTH OF KENTUCKY
COUNTY OF Jackson:

Subscribed, sworn to and acknowledged before me by Keith Gabbard, the President of East Kentucky Network, LLC d/b/a Appalachian Wireless on the 8th day of October, 2020.

Beverly Fee
Notary Public
Commission No.: KYND 7542

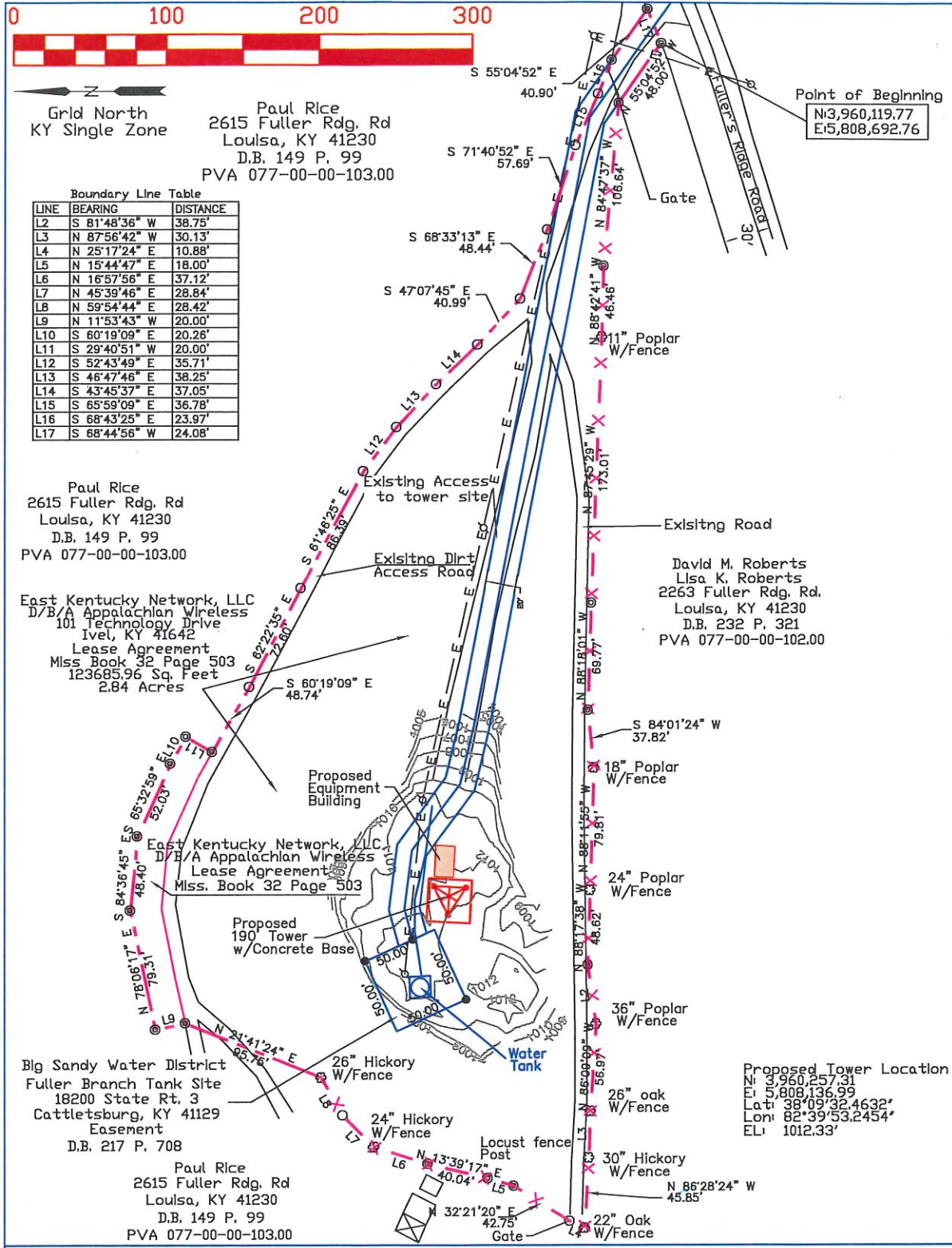
My Commission Expires: 5/18/2024

This instrument prepared by:

Cindy D. McCarty
Cindy D. McCarty, Attorney
101 Technology Trail
Ivel, Kentucky 41642
(606) 339-1006

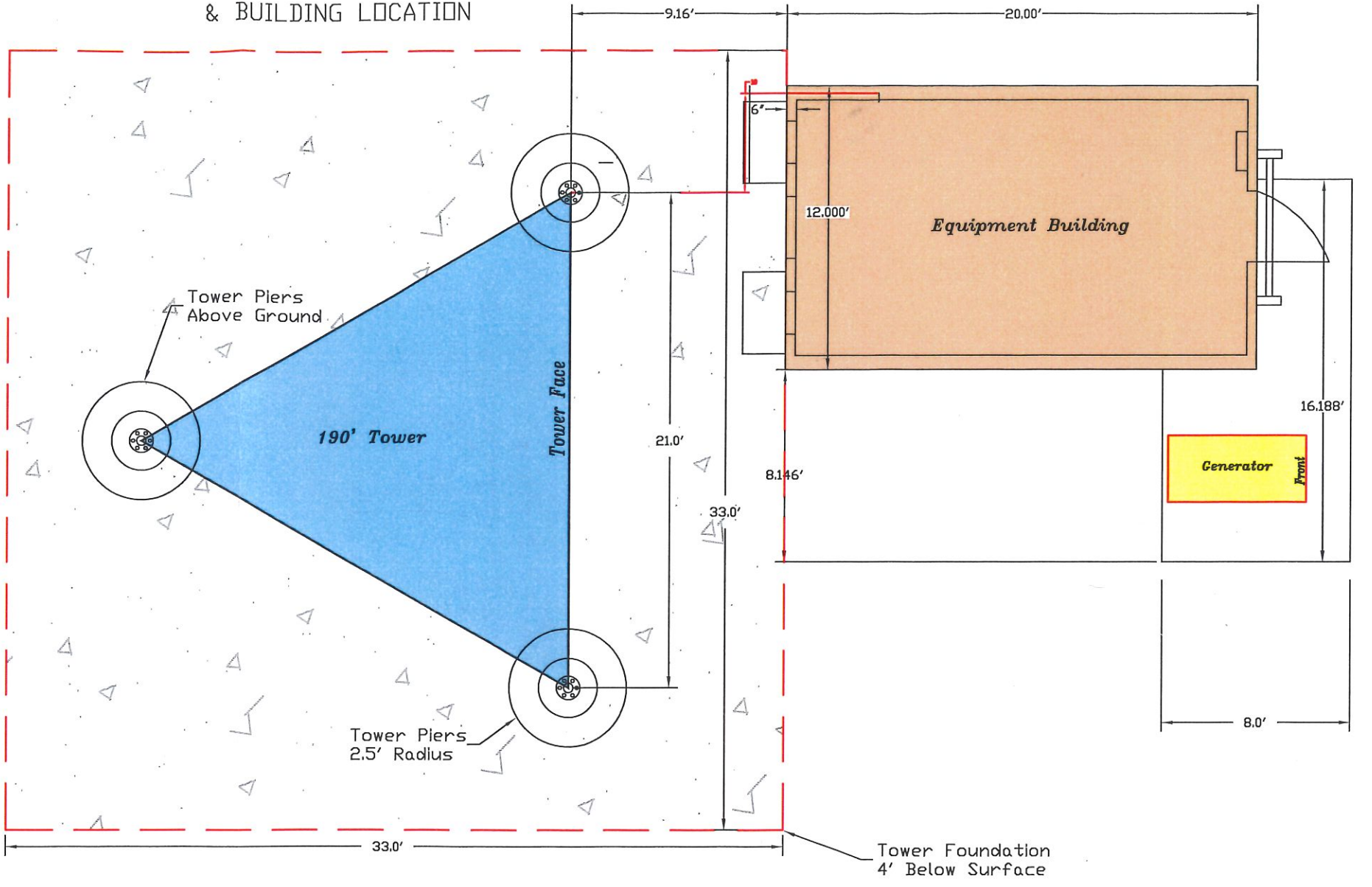


Exhibit 9



FULLER RIDGE TOWER

SITE SURVEY WITH PROPOSED TOWER & BUILDING LOCATION



FAA Certification

Note: Tower Foundation & distance between Tower Legs may change due to design criteria, by others.
Note: This is a Site Plan of the tower indicating the proposed Tower & Tower Component location. No design criteria was considered in the preparation of this drawing.

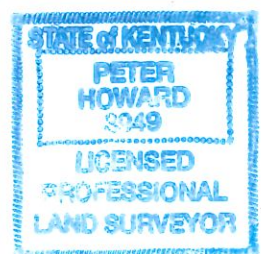
David Rasnick 12/9/20
David Rasnick PE# 12,713 DATE



Legend

- ⊙ 1/2" re-bar set with a plastic cap stamped Summit Engineering, L.S. #3949 unless otherwise noted.
- △ Proposed Tower Location
- Boundary
- - - Adjoining Property Lines

Peter Howard, PLS #3949
265 Hambley Blvd.
Pikeville, KY 41501
606-432-1447



David Rasnick #12,713
265 Hambley Blvd.
Pikeville, KY 41501
606-432-1447

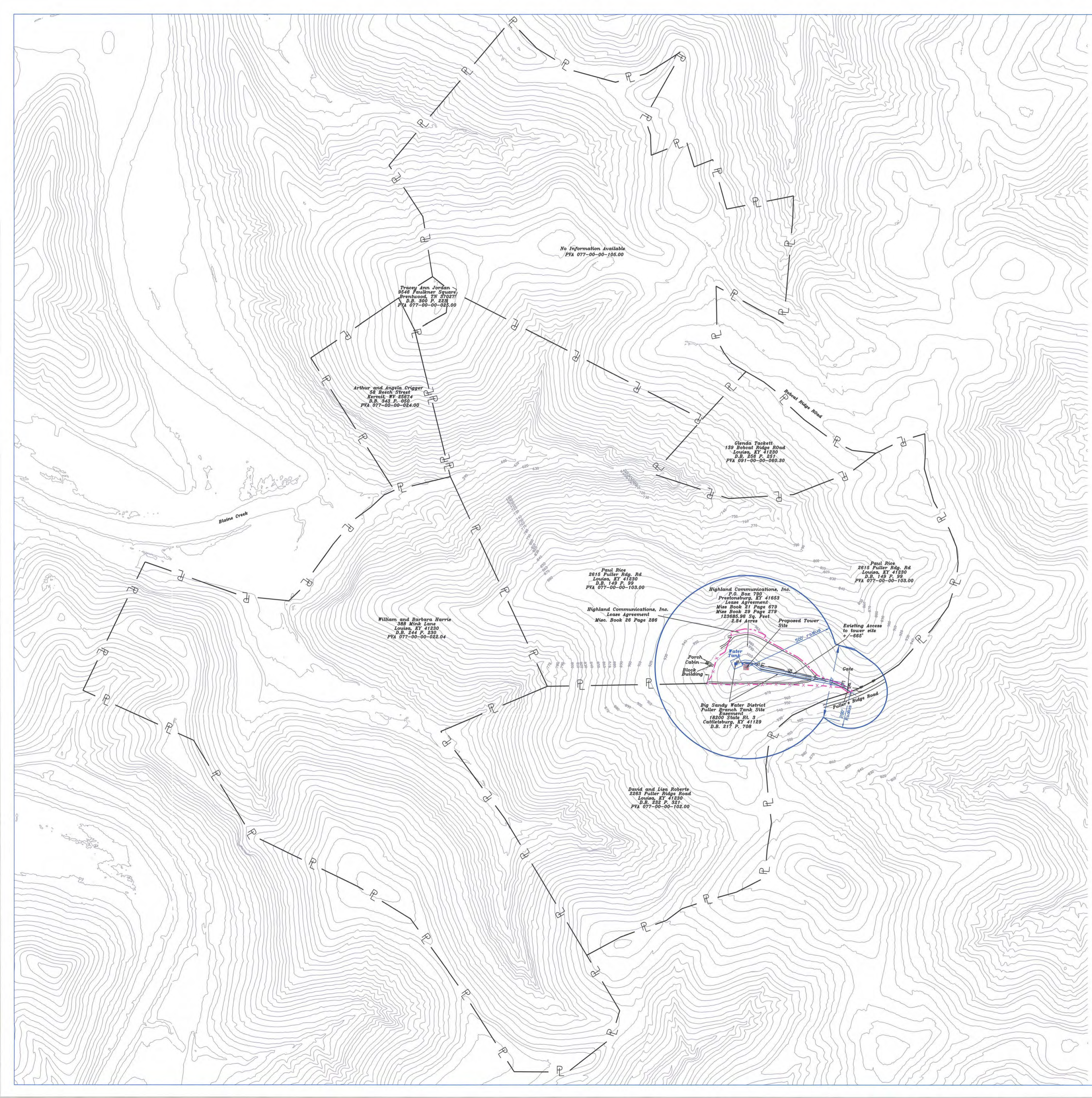
EAST KENTUCKY NETWORK D/B/A APPALACHIAN WIRELESS 101 TECHNOLOGY TRAIL, IVEL, KY 41643				SUMMIT ENGINEERING, INC 265 HAMBLEY BLVD. PIKEVILLE, KY. 41501 (606) 432-1447	
Fuller Ridge Tower Site Map Located Along Fuller Ridge Road Lawrence County, KY					
Scale: As Noted	Drawn By: PH	Chk By: PH	Apprvd. By:	PER. NO:	
Plot Date:				ATT:	
File Name: Z:\East Ky Network\Fuller Ridge Tower\Fuller Ridge 09-30-2020\Fuller Ridge Site Plan-revised.dwg					

FAA Certification

In Accordance with FAA Order 8260.195, Appendix C, I hereby certify that the Obstacle Accuracy Codes for the proposed tower meets or exceeds accuracy 2C (+50 ft Horizontal and +20 ft Vertical).

Peter Howard 12/9/2020
Peter Howard, PLS #3949 Date

Exhibit 10



UTILITIES

Electric
 American Electric Power
 23000 U.S. 23
 Louisa, KY 41230
 (606)-886-2415

Telephone & Cable
 Foothills Communications
 1621 KY Route 40 West
 Staffordsville, KY 41256
 (606)-673-3193

Water & Sewer
 Rattlesnake Ridge Dist.
 PO Box 475
 Crayson, KY 41143
 (606)-474-7570

Natural Gas
 Frontier Natural Gas
 PO Box 408
 Prestonsburg, KY 41653
 (606)-886-2431



The tract of land shown hereon is located on Fullers Ridge Road between Blaine Creek and the Big Sandy River, Lawrence County, Kentucky.

The proposed tower shown hereon is located on the same tracts of land per lease agreement between Highland Communications, Inc. by Paul Rice with an effective date of May 16, 1987 and recorded in Misc. Book 21 Page 679 and renewed on May 05, 2007 and recorded in Misc. Book 29 Page 279, lodged in the Lawrence County Clerk's Office.

Property lines shown hereon are based on information provided by the Lawrence County PVA office.

Access from the intersection of U.S. 23 and Waller Branch Road. Travel West on Waller Branch Road for 1.531/- miles to the intersection of Waller Branch Road and Fullers Branch Road. Turn right onto Fullers Branch Road and drive north for 0.83 +/- miles to the tower access road on left.

Topography of the area surrounding the tower site is forest covered rolling hill terrain with slopes ranging from 2.00% to 30%. Land use within the 600' radius is undisturbed forest with a water tank and hillside property.

Contours shown hereon were taken from Lidar Mapping.
 Contour interval = 10'

Summit Engineering, Inc. makes no warranty as to the title or ownership of property.

Adjoining land owners listed are based on Property Valuation Administration (PVA) records issued by a representative from Lawrence County, to be in compliance with all statutory and regulatory requirements before the Kentucky Public Service Commission and for telecommunication.

Proposed tower site IS NOT in the 100 year flood hazard area and has a average elevation of 1,012'. Firm Map 210258 0210 D Map Effective: June 16, 2011

The utility lines shown hereon represent the utilities as they were observed in the field. The lines and structures have not been marked therefor, the locations of all utilities may not be shown.

Tracy Ann Jordan
 9540 Paulsner Square
 Brentwood, TN 37027
 D.B. 300 P. 223
 PVA 077-00-00-023.00

Arthur and Angela Origer
 58 Beech Street
 Armitage, TN 38374
 D.B. 343 P. 059
 PVA 077-00-00-024.00

Glenda Tackett
 139 Bobcat Ridge Road
 Louisa, KY 41230
 D.B. 248 P. 521
 PVA 091-00-00-080.30

Paul Rice
 2616 Fuller Rd. Rd
 Louisa, KY 41230
 D.B. 145 P. 90
 PVA 077-00-00-103.00

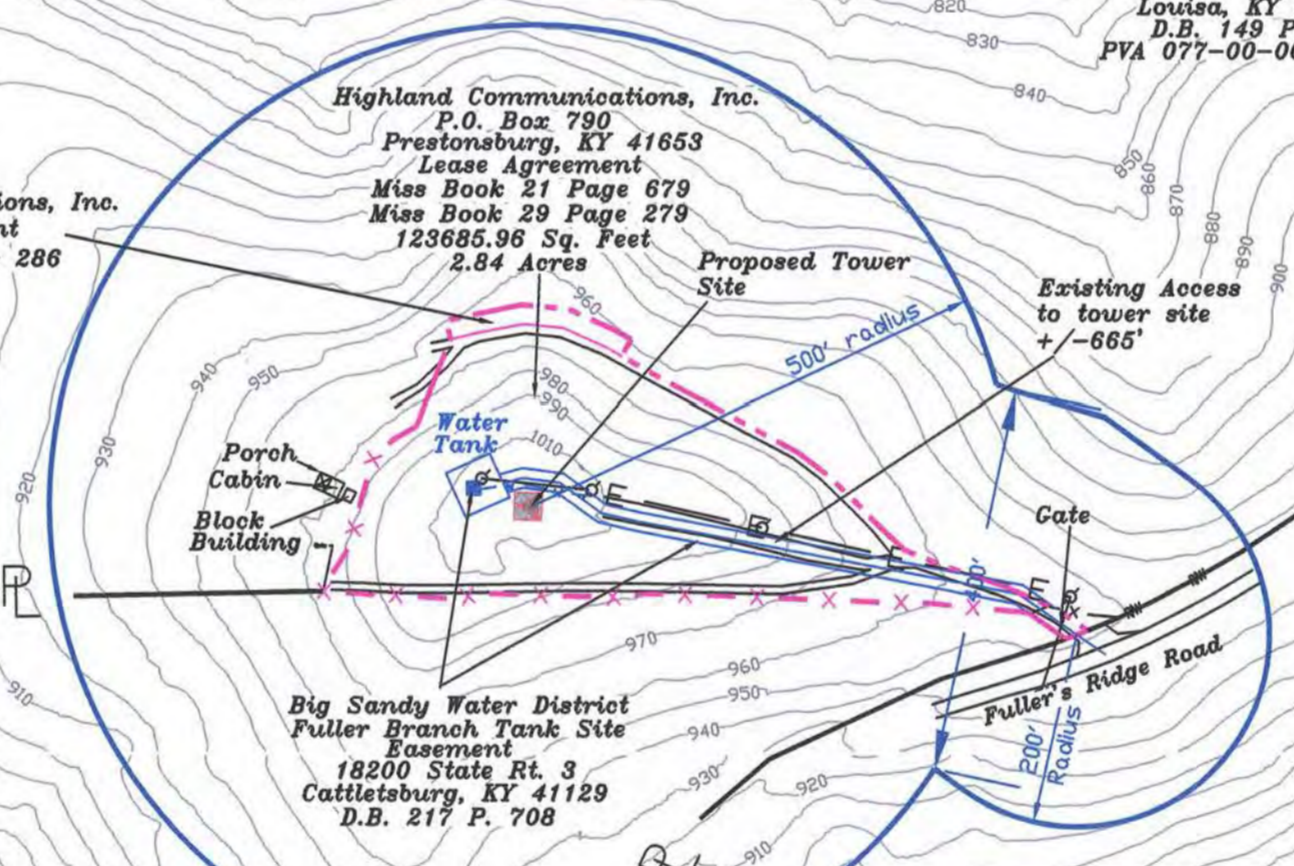
Paul Rice
 2616 Fuller Rd. Rd
 Louisa, KY 41230
 D.B. 145 P. 90
 PVA 077-00-00-103.00

Highland Communications, Inc.
 P.O. Box 780
 Prestonsburg, KY 41653
 Lease Agreement
 Misc Book 21 Page 679
 Misc Book 29 Page 279
 123886.90 Sq. Feet
 2.54 Acres

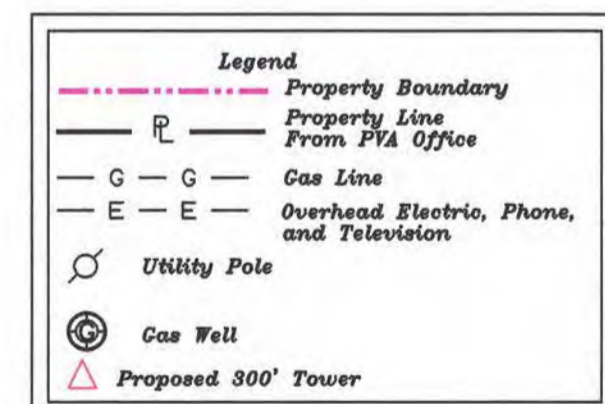
Highland Communications, Inc.
 Lease Agreement
 Misc. Book 28 Page 286

William and Barbara Harris
 288 Mink Lane
 Louisa, KY 41230
 D.B. 244 P. 230
 PVA 077-00-00-028.04

David and Lisa Roberts
 2283 Fuller Ridge Road
 Louisa, KY 41230
 D.B. 232 P. 321
 PVA 077-00-00-102.00



Note: Property lines shown hereon have not been surveyed in the field. This map is for exhibit only and not for the sale or transfer of property.



Peter Howard, PLS 3949
 266 Hambley Bl.
 Knoxville, TN 37901
 606-582-1447



I hereby certify that the information depicted by this map is correct to the best of my knowledge and is in accordance with the record data as found in the office of the Property Valuation Administrator of Lawrence County, Kentucky.

Peter Howard PLS No. 3949 Date: 12/10/2020

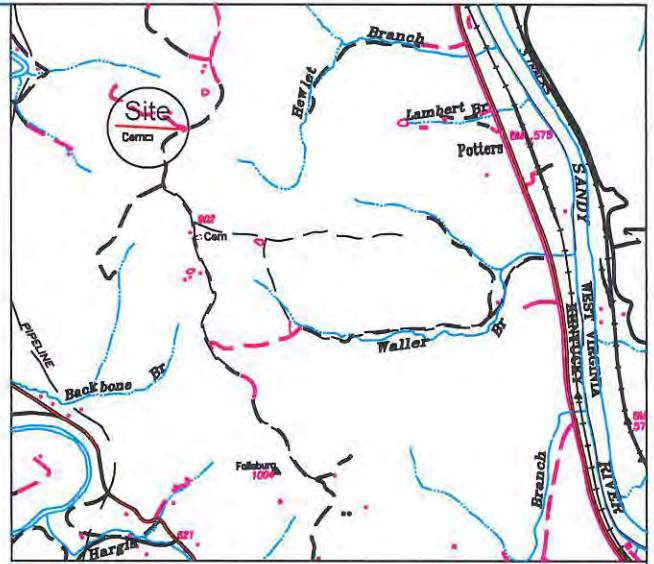
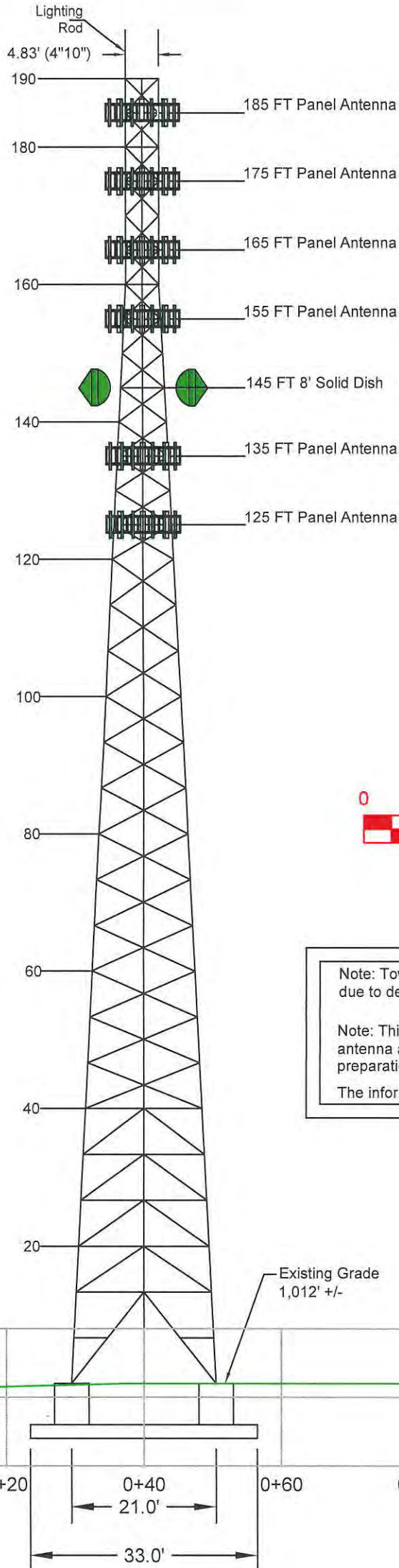
EAST KENTUCKY NETWORK 101 Technology Trail, Ivel, KY 41642 Property Owner Map Fuller Ridge Tower Fuller Ridge Road, Lawrence County, KY		SUMMIT ENGINEERING, INC. 244 E. Main Street Ivel, KY 41642 PH: 606-321-1447 FAX: 606-321-1447		
Scale: 1"=200'	Drawn By: []	Chk By: []	Apprv. By: []	PER. NO: []
Plot Date: 10 DECEMBER 2020 - 1:14 PM	ATT: []		ATT: []	
File Name: 21\Est\Ky\Hwrd\Fuller Ridge Tower\Fuller Ridge 00-30-2020\3C Map\Fuller Ridge Tower Property Map.dwg				



Exhibit 11

Fuller Ridge Tower

VERTICAL PROFILE SKETCH
EAST KENTUCKY NETWORK
d/b/a APPALACHIAN WIRELESS



Vicinity Map
Not to Scale
Fallsburg, KY
7 1/2' Quadrangle Map

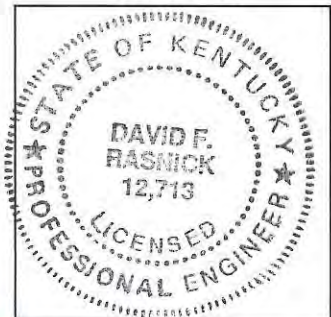


Note: Tower Foundation & distance between Tower Legs may change due to design criteria, by others.

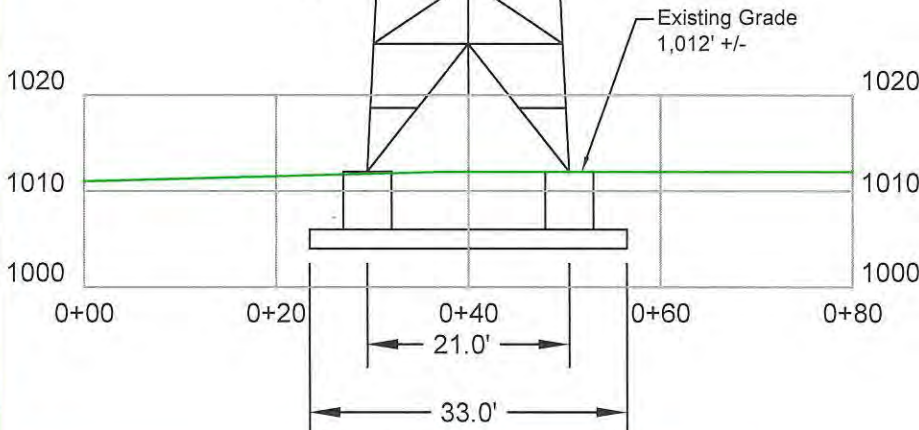
Note: This is a vertical sketch of the tower indicating the proposed antenna and dish elevations. No design criteria was considered in the preparations of this drawing.

The information shown hereon is correct to the best of my knowledge

David Rasnick, PE #12,713
265 Hambley Blvd.
Pikeville, KY 41501
606-432-1447



David Rasnick 12/9/20
David Rasnick PE #12,713 Date




DATE: 12/09/2020	FILENAME:	East Kentucky Network d/b/a Appalachian Wireless 101 Technology Trail, Ivel, KY 41642	SUMMIT ENGINEERING INC. 
SCALE: 1"=20'	DISK NO.		
DRAWN BY: PH		Vertical Profile Sketch Fuller Ridge Tower Lawrence County, Kentucky	265 Hambley BLVD PO Box 3007 Pikeville, KY 41502 606-432-1447 Pikeville, KY Lexington, KY S. Charleston, WV

Exhibit 12

Utility ID	Utility Name	Utility Type	Class	City	State
4107900	365 Wireless, LLC	Cellular	D	Atlanta	GA
4109300	Access Point, Inc.	Cellular	D	Cary	NC
4108300	Air Voice Wireless, LLC	Cellular	A	Bloomfield Hill	MI
4110650	Alliant Technologies of KY, L.L.C.	Cellular	C	Morristown	NJ
44451184	Alltel Communications, LLC	Cellular	A	Basking Ridge	NJ
4110850	AltaWorx, LLC	Cellular	C	Fairhope	AL
4107800	American Broadband and Telecommunications Company	Cellular	C	Toledo	OH
4108650	AmeriMex Communications Corp.	Cellular	D	Dunedin	FL
4105100	AmeriVision Communications, Inc. d/b/a Affinity 4	Cellular	D	Virginia Beach	VA
4110700	Andrew David Balholm dba Norcell	Cellular	C	Clayton	WA
4108600	BCN Telecom, Inc.	Cellular	D	Morristown	NJ
4110550	Blue Casa Mobile, LLC	Cellular	D	Santa Barbara	CA
4108750	Blue Jay Wireless, LLC	Cellular	C	Carrollton	TX
4111050	BlueBird Communications, LLC	Cellular	C	New York	NY
4202300	Bluegrass Wireless, LLC	Cellular	A	Elizabethtown	KY
4107600	Boomerang Wireless, LLC	Cellular	B	Hiawatha	IA
4105500	BullsEye Telecom, Inc.	Cellular	D	Southfield	MI
4110050	CampusSims, Inc.	Cellular	D	Boston	MA
4100700	Cellco Partnership dba Verizon Wireless	Cellular	A	Basking Ridge	NJ
4106600	Cintex Wireless, LLC	Cellular	D	Rockville	MD
4111000	ComApp Technologies LLC	Cellular	C	Melrose	MA
4101900	Consumer Cellular, Incorporated	Cellular	A	Portland	OR
4106400	Credo Mobile, Inc.	Cellular	A	San Francisco	CA
4108850	Cricket Wireless, LLC	Cellular	A	San Antonio	TX
4001900	CTC Communications Corp. d/b/a EarthLink Business I	Cellular	D	Grand Rapids	MI
10640	Cumberland Cellular Partnership	Cellular	A	Elizabethtown	KY
4101000	East Kentucky Network, LLC dba Appalachian Wireless	Cellular	A	Ivel	KY
4002300	Easy Telephone Service Company dba Easy Wireless	Cellular	D	Ocala	FL
4109500	Enhanced Communications Group, LLC	Cellular	D	Bartlesville	OK
4110450	Excellus Communications, LLC	Cellular	D	Chattanooga	TN
4105900	Flash Wireless, LLC	Cellular	C	Concord	NC
4104800	France Telecom Corporate Solutions L.L.C.	Cellular	D	Oak Hill	VA
4109350	Global Connection Inc. of America	Cellular	D	Norcross	GA
4102200	Globalstar USA, LLC	Cellular	B	Covington	LA
4109600	Google North America Inc.	Cellular	A	Mountain View	CA
33350363	Granite Telecommunications, LLC	Cellular	D	Quincy	MA
4106000	GreatCall, Inc. d/b/a Jitterbug	Cellular	A	San Diego	CA
10630	GTE Wireless of the Midwest dba Verizon Wireless	Cellular	A	Basking Ridge	NJ
4110600	Horizon River Technologies, LLC	Cellular	C	Atlanta	GA
4103100	i-Wireless, LLC	Cellular	A	Newport	KY
4109800	IM Telecom, LLC d/b/a Infiniti Mobile	Cellular	D	Tulsa	OK
22215360	KDDI America, Inc.	Cellular	D	New York	NY
10872	Kentucky RSA #1 Partnership	Cellular	A	Basking Ridge	NJ
10680	Kentucky RSA #3 Cellular General	Cellular	A	Elizabethtown	KY
10681	Kentucky RSA #4 Cellular General	Cellular	A	Elizabethtown	KY
4109750	Konatel, Inc. dba telecom.mobi	Cellular	D	Johnstown	PA
4110900	Lunar Labs, Inc.	Cellular	C	Detroit	MI
4107300	Lycamobile USA, Inc.	Cellular	D	Newark	NJ
4108800	MetroPCS Michigan, LLC	Cellular	A	Bellevue	WA
4109650	Mitel Cloud Services, Inc.	Cellular	D	Mesa	AZ
4202400	New Cingular Wireless PCS, LLC dba AT&T Mobility, PCS	Cellular	A	San Antonio	TX
10900	New Par dba Verizon Wireless	Cellular	A	Basking Ridge	NJ
4000800	Nextel West Corporation	Cellular	D	Overland Park	KS
4001300	NPCR, Inc. dba Nextel Partners	Cellular	D	Overland Park	KS

4001800	OnStar, LLC	Cellular	A	Detroit	MI
4110750	Onvoy Spectrum, LLC	Cellular	C	Plymouth	MN
4109050	Patriot Mobile LLC	Cellular	D	Southlake	TX
4110250	Plintron Technologies USA LLC	Cellular	D	Bellevue	WA
33351182	PNG Telecommunications, Inc. dba PowerNet Global Communications	Cellular	D	Cincinnati	OH
4202100	Powertel/Memphis, Inc. dba T-Mobile	Cellular	A	Bellevue	WA
4107700	Puretalk Holdings, LLC	Cellular	A	Covington	GA
4106700	Q Link Wireless, LLC	Cellular	A	Dania	FL
4108700	Ready Wireless, LLC	Cellular	B	Hiawatha	IA
4110500	Republic Wireless, Inc.	Cellular	D	Raleigh	NC
4111100	ROK Mobile, Inc.	Cellular	C	Culver City	CA
4106200	Rural Cellular Corporation	Cellular	A	Basking Ridge	NJ
4108550	Sage Telecom Communications, LLC dba TruConnect	Cellular	D	Los Angeles	CA
4109150	SelecTel, Inc. d/b/a SelecTel Wireless	Cellular	D	Freemont	NE
4106300	SI Wireless, LLC	Cellular	A	Carbondale	IL
4110150	Spectrotel, Inc. d/b/a Touch Base Communications	Cellular	D	Neptune	NJ
4200100	Sprint Spectrum, L.P.	Cellular	A	Atlanta	GA
4200500	SprintCom, Inc.	Cellular	A	Atlanta	GA
4109550	Stream Communications, LLC	Cellular	D	Dallas	TX
4110200	T C Telephone LLC d/b/a Horizon Cellular	Cellular	D	Red Bluff	CA
4202200	T-Mobile Central, LLC dba T-Mobile	Cellular	A	Bellevue	WA
4002500	TAG Mobile, LLC	Cellular	D	Carrollton	TX
4109700	Telecom Management, Inc. dba Pioneer Telephone	Cellular	D	South Portland	ME
4107200	Telefonica USA, Inc.	Cellular	D	Miami	FL
4108900	Telrite Corporation dba Life Wireless	Cellular	D	Covington	GA
4108450	Tempo Telecom, LLC	Cellular	D	Kansas City	MO
4109950	The People's Operator USA, LLC	Cellular	D	New York	NY
4109000	Ting, Inc.	Cellular	A	Toronto	ON
4110400	Torch Wireless Corp.	Cellular	D	Jacksonville	FL
4103300	Touchtone Communications, Inc.	Cellular	D	Whippany	NJ
4104200	TracFone Wireless, Inc.	Cellular	D	Miami	FL
4002000	Truphone, Inc.	Cellular	D	Durham	NC
4110300	UVNV, Inc.	Cellular	D	Costa Mesa	CA
4105700	Virgin Mobile USA, L.P.	Cellular	A	Atlanta	GA
4110800	Visible Service LLC	Cellular	C	Lone Tree	CO
4106500	WiMacTel, Inc.	Cellular	D	Palo Alto	CA
4110950	Wing Tel Inc.	Cellular	C	New York	NY
4109900	Wireless Telecom Cooperative, Inc. dba theWirelessFreeway	Cellular	D	Louisville	KY

Exhibit 13

S & S Tower Services
120 Branden Dr.
Mousie, KY 41839

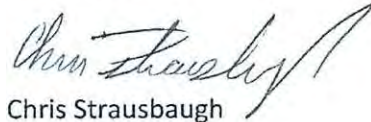
Kentucky Public Service Commission
211 Sower Blvd.
P.O. Box 615
Frankfort, KY 40602-0615

Dear Commissioners:

The Construction Manager for the proposed communications facility will be Dave Strausbaugh. His contact information is (606) 497-6730 or dstrausbaugh010@gmail.com.

Dave has been in the industry completing civil construction and constructing towers since 1991. He has worked for S&S Tower Services since 2015 as Construction Manager overseeing the construction of telecommunications towers and sites.

Thank you,



Chris Strausbaugh
Owner
S&S Tower Services
(606) 497-5798