

**COMMONWEALTH OF KENTUCKY**  
**BEFORE THE PUBLIC SERVICE COMMISSION**

**In the Matter of:**

<b>ELECTRONIC APPLICATION OF LOUISVILLE</b>	)	
<b>GAS AND ELECTRIC COMPANY FOR AN</b>	)	
<b>ADJUSTMENT OF ITS ELECTRIC AND GAS</b>	)	
<b>RATES, A CERTIFICATE OF PUBLIC</b>	)	
<b>CONVENIENCE AND NECESSITY TO DEPLOY</b>	)	<b>CASE NO. 2020-00350</b>
<b>ADVANCED METER INFRASTRUCTURE,</b>	)	
<b>APPROVAL OF CERTAIN REGULATORY AND</b>	)	
<b>ACCOUNTING TREATMENTS, AND</b>	)	
<b>ESTABLISHMENT OF A ONE-YEAR</b>	)	
<b>SURCREDIT</b>	)	

**RESPONSE OF**  
**LOUISVILLE GAS AND ELECTRIC COMPANY**  
**TO**  
**COMMISSION STAFF'S FIFTH REQUEST FOR INFORMATION**  
**DATED MARCH 19, 2021**

**FILED: APRIL 1, 2021**

**VERIFICATION**

**COMMONWEALTH OF KENTUCKY   )**  
  )  
**COUNTY OF JEFFERSON        )**

The undersigned, **Daniel K. Arbough**, being duly sworn, deposes and says that he is Treasurer for Kentucky Utilities Company and Louisville Gas and Electric Company and an employee of LG&E and KU Services Company, and that he has personal knowledge of the matters set forth in the responses for which he is identified as the witness, and the answers contained therein are true and correct to the best of his information, knowledge and belief.

  
\_\_\_\_\_ )  
**Daniel K. Arbough**

Subscribed and sworn to before me, a Notary Public in and before said County and State, this 29<sup>th</sup> day of March \_\_\_\_\_ 2021.

  
\_\_\_\_\_ )  
Notary Public  
Notary Public ID No. 603967

My Commission Expires:

**July 11, 2022**



VERIFICATION

COMMONWEALTH OF KENTUCKY )  
 )  
COUNTY OF JEFFERSON )

The undersigned, **Kent W. Blake**, being duly sworn, deposes and says that he is Chief Financial Officer for Kentucky Utilities Company and Louisville Gas and Electric Company and an employee of LG&E and KU Services Company, and that he has personal knowledge of the matters set forth in the responses for which he is identified as the witness, and the answers contained therein are true and correct to the best of his information, knowledge and belief.



**Kent W. Blake**

Subscribed and sworn to before me, a Notary Public in and before said County and State, this 29<sup>th</sup> day of March 2021.

  
Notary Public

Notary Public ID No. 603967

My Commission Expires:

**July 11, 2022**



**VERIFICATION**

**COMMONWEALTH OF KENTUCKY )**  
**)**  
**COUNTY OF JEFFERSON )**

The undersigned, **Robert M. Conroy**, being duly sworn, deposes and says that he is Vice President, State Regulation and Rates, for Kentucky Utilities Company and Louisville Gas and Electric Company and an employee of LG&E and KU Services Company, and that he has personal knowledge of the matters set forth in the responses for which he is identified as the witness, and the answers contained therein are true and correct to the best of his information, knowledge and belief.

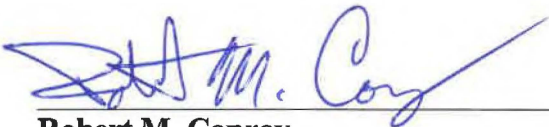
  
\_\_\_\_\_ **Robert M. Conroy**

Subscribed and sworn to before me, a Notary Public in and before said County and State, this 31<sup>st</sup> day of March 2021.

  
\_\_\_\_\_ Notary Public  
Notary Public ID No. **603967**

My Commission Expires:

**July 11, 2022**

VERIFICATION

STATE OF TEXAS )  
 )  
COUNTY OF TRAVIS )

The undersigned, **Adrien McKenzie**, being duly sworn, deposes and states that he is a President of FINCAP, Inc., and that he has personal knowledge of the matters set forth in the responses for which he is identified as the witness, and the answers contained therein are true and correct to the best of his information, knowledge and belief.

  
Adrien McKenzie

Subscribed and sworn to before me, a Notary Public in and before said County and State, this 30th day of MARCH 2021.

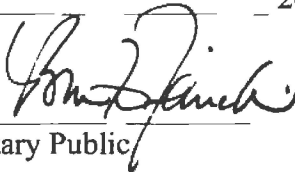
 (SEAL)  
Notary Public

Notary Public ID No. 131906507

My Commission Expires:

2/25/2023

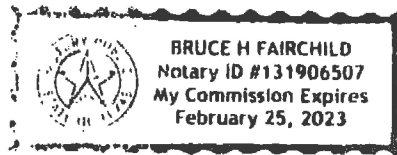

**VERIFICATION**

**COMMONWEALTH OF KENTUCKY** )  
 )  
**COUNTY OF JEFFERSON** )

The undersigned, **Eileen L. Saunders**, being duly sworn, deposes and says that she is Vice President, Customer Services for Louisville Gas and Electric Company and Kentucky Utilities Company and an employee of LG&E and KU Services Company, and that she has personal knowledge of the matters set forth in the responses for which she is identified as the witness, and the answers contained therein are true and correct to the best of her information, knowledge and belief.

  
\_\_\_\_\_  
**Eileen L. Saunders**

Subscribed and sworn to before me, a Notary Public in and before said County and State, this 29<sup>th</sup> day of March 2021.

  
\_\_\_\_\_  
Notary Public  
Notary Public ID No. KY NP 14646

My Commission Expires:

10-16-2024

VERIFICATION

STATE OF NORTH CAROLINA )  
 )  
COUNTY OF BUNCOMBE )

The undersigned, **William Steven Seelye**, being duly sworn, deposes and states that he is a Principal of The Prime Group, LLC, and that he has personal knowledge of the matters set forth in the responses for which he is identified as the witness, and the answers contained therein are true and correct to the best of his information, knowledge and belief.

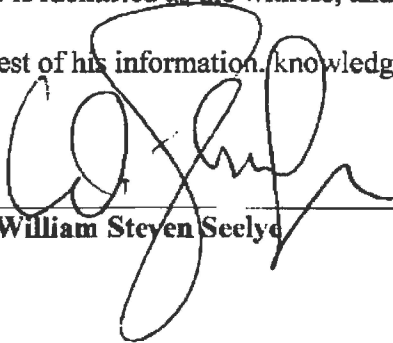
  
\_\_\_\_\_  
William Steven Seelye

Subscribed and sworn to before me, a Notary Public in and before said County and State, this 31<sup>st</sup> day of March 2021.

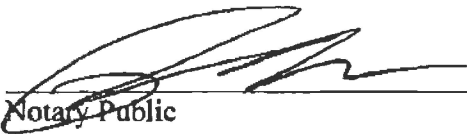
 (SEAL)  
\_\_\_\_\_  
Notary Public

Notary Public ID No. \_\_\_\_\_

My Commission Expires:

3-7-26

**Bryant P. Cooper**  
Notary Public  
Buncombe County, NC  
My Commission Expires: 03/07/26

**VERIFICATION**

**COMMONWEALTH OF KENTUCKY )**  
**)**  
**COUNTY OF JEFFERSON )**

The undersigned, **John K. Wolfe**, being duly sworn, deposes and says that he is Vice President, Electric Distribution for Kentucky Utilities Company and Louisville Gas and Electric Company and an employee of LG&E and KU Services Company, and that he has personal knowledge of the matters set forth in the responses for which he is identified as the witness, and the answers contained therein are true and correct to the best of his information, knowledge and belief.

  
\_\_\_\_\_  
**John K. Wolfe**

Subscribed and sworn to before me, a Notary Public in and before said County and State, this 29th day of March 2021.

  
\_\_\_\_\_  
Notary Public

Notary Public ID No. **603967**

My Commission Expires:

**July 11, 2022**  
\_\_\_\_\_

**LOUISVILLE GAS AND ELECTRIC COMPANY**

**Response to Commission Staff's Fifth Request for Information**  
**Dated March 19, 2021**

**Case No. 2020-00350**

**Question No. 1**

**Responding Witness: Lonnie E. Bellar**

- Q-1. Provide the date in which LG&E officially made its decision to propose, as part of the instant rate application, to shorten the remaining useful lives of LG&E's coal-fired generation units for depreciation purposes
- A-1. The examination of the retirement dates in Exhibit LEB-2, Analysis of Generating Unit Retirement Years, was conducted between July and September 2020; the determinations concerning the retirement dates in the analysis were established in October 2020 when the report was finalized and issued.

Mill Creek Unit 1's retirement date was changed from 2032 to 2024 as a result of the decision to install ELG water treatment capacity for only three of four Mill Creek units based on the 2020 Environmental Compliance Plan presented in Case No. 2020-00061, *Electronic Application of Louisville Gas and Electric Company for Approval of Its 2020 Compliance Plan for Recovery by Environmental Surcharge*. This decision was finalized in September 2020 with the issuance of the Commission's order approving LG&E's ECR environmental compliance plan.

The Companies for many years have continuously evaluated the risk of the retirement of their generation units through their annual planning process. In addition, in their 2018 IRP (Case No. 2018-00348), the Companies' evaluated 55- and 65-year operating lives for all coal units. Further in the Companies' 2020 ECR Plan presented in Case Nos. 2020-00060 and 2020-00061, after demonstrating that the ELG investments were least-cost based on the assumed retirement years, the Companies evaluated the risk of early retirement for the Mill Creek, Ghent, and Trimble County coal units by identifying the year through which the units must operate to justify the ELG investments. For the Mill Creek station, the analysis demonstrated that installing water treatment capacity for three Mill Creek units is least-cost even if Mill Creek Unit 2 is retired at the end of 2028.

The retirement dates identified in Exhibit LEB-2 do not affect or otherwise change the conclusions and plans in the Companies' 2020 Environmental Compliance Plan. As discussed in Exhibit LEB-2, the Companies now expect

that SCR will be required on Mill Creek Unit 2 between 2027 and 2029 to comply with current and future NAAQS (see Exhibit LEB-2 at page 5 and the broader discussion beginning at page 4). This expectation is largely based on exceedances of the 70 parts-per-billion 2015 NAAQS ozone standard in the Jefferson County area during the 2020 ozone season, which were not known when the analysis supporting the 2020 ECR Plan was completed in the first quarter of 2020.

**LOUISVILLE GAS AND ELECTRIC COMPANY**

**Response to Commission Staff's Fifth Request for Information  
Dated March 19, 2021**

**Case No. 2020-00350**

**Question No. 2**

**Responding Witness: Daniel K. Arbough**

- Q-2. Refer to the Application, Tab 59, Schedule F-6 Professional Service Expenses, page 8 of 10. Provide a detailed analysis of the budgeted legal fees for the forecasted test period.
- A-2. See attached which shows the detail of outside counsel legal fees that make up LG&E's legal fees shown in the Attachment to Filing Requirement, Table 59 – 807 KAR 5:001 Section 16(8)(f), page 8 of 10. When creating the budget for this area of expense the Company estimates legal expenses by matter for the first year in the Business Plan; for purposes of the Business Plan supporting LG&E's application in this rate case that would be 2021. As such, the forecasted test period is an estimate based on matters expected during 2021 and matters that may continue into or develop in 2022.



The attachment is being provided in a separate file in Excel format.

**LOUISVILLE GAS AND ELECTRIC COMPANY**

**Response to Commission Staff's Fifth Request for Information**  
**Dated March 19, 2021**

**Case No. 2020-00350**

**Question No. 3**

**Responding Witness: Adrien M. McKenzie**

Q-3. Refer to the Direct Testimony of Adrian M. McKenzie, pages 14–18. There have been recent ROE awards to electric utilities with only transmission and distribution assets that have been below 9.0 percent.

- a. Everything else being equal, explain generally whether “wires only” utilities are less risky than vertically integrated electric utilities that own and operate generation facilities. If so, explain the risk factors associated with the ownership and operation of generation facilities that enhances the utilities’ risk.
- b. Provide a detailed explanation of how each of the risk factors enumerated above relate specifically to LG&E. Include in the response an explanation of how the well-established rate recovery mechanisms and regulatory processes fail to alleviate any additional risk such that a higher awarded ROE is warranted.

A-3. The most recent RRA Regulatory Focus report reported that for 2020 there were only six electric distribution utility rate proceedings with ROEs below 9.0% out of the total of 55 cases surveyed.<sup>1</sup> In three of those cases, RRA indicated that the ROE was the result of a stipulation or settlement, noting that “[d]ecision particulars [are] not necessarily precedent setting or specifically adopted by the regulatory body.”

Apart from whether the utility is “wires-only” or vertically integrated, other case-specific features differentiate these outcomes from the vast majority of regulatory commission findings and from the circumstances faced by LG&E. For example, the three cases that established ROEs of 8.80% through stipulation or settlement in New York also included provisions for multi-year rate plans, earnings sharing, and revenue decoupling.

---

<sup>1</sup> S&P Market Intelligence, *Major Rate Case Decisions – January–December 2020*, RRA Regulatory Focus (Feb. 2, 2021). Provided as Supplemental Response to PSC 2-69(b), filed Feb, 9, 2021.

Similarly, the 8.38% ROEs set for Ameren Illinois Company (Ameren Illinois) and Commonwealth Edison Company (ComEd) reflect the results of an ROE mechanism approved in connection with a performance-based formula ratemaking framework that includes full revenue decoupling of electric rates. Under the formula, ROE is computed as a fixed 580 basis points above the rate on 30-year Treasury bonds. As indicated in Mr. McKenzie's direct testimony (pp. 20-21), changes in the magnitude—or even direction—of yields on Treasury securities do not serve as a direct guide to movements in the cost of equity for utilities. Nor does this ROE reflect the Illinois Commerce Commission's (ICC) current assessment of the cost of capital for utilities. For example, the ICC approved an ROE of 9.67% for Ameren Illinois' gas utility operations in January 2021, with a 52% common equity ratio.<sup>2</sup> S&P indicated that pending legislation in Illinois would raise the risk premium over Treasury bond yields by 100 basis points, which would imply an ROE above 9% for Ameren Illinois' and ComEd's electric utility operations.<sup>3</sup>

Meanwhile, a February 19, 2020 order from the Maine Public Utilities Commission (MPUC) approved a 9.25% ROE for Central Maine Power Company (CMP). However, the MPUC also imposed a 1.00% ROE reduction (to 8.25%) for management efficiency associated with CMP's customer service performance following with implementation of a new billing system in 2017. The 1.00% management efficiency adjustment will be removed once CMP has demonstrated satisfactory customer service performance on specific quality measures for a rolling average period of 18 months.

- a. The extent to which a utility is “wires only” or vertically integrated represents one salient aspect of investors' evaluation of a utility's risk exposure. The construction and operation of generation facilities entails a number of risks that are not faced by energy distribution utilities, including exposure to risks regarding the prudence of construction and fuel procurement, combustion waste, concerns regarding carbon transition risks, and the financial pressures associated with supporting related capital investment programs to ensure adequate generating capacity and meet other societal mandates, such as environmental compliance and renewables goals.
- b. Through its ownership of generation assets, LG&E is exposed to all the risks enumerated in subpart (a). As S&P Global Ratings concluded, “[T]he company has about 3,000 megawatts of generation capacity, which entails greater operating risk than its transmission and distribution operations.”<sup>4</sup>

---

<sup>2</sup> Ameren Illinois Company, 2020 Form 10-K Report at p. 8. Available at: [https://www.sec.gov/ix?doc=/Archives/edgar/data/18654/000100291021000065/aee-20201231.htm#f2f6a31d3bf04a31946c203851e6d676\\_28](https://www.sec.gov/ix?doc=/Archives/edgar/data/18654/000100291021000065/aee-20201231.htm#f2f6a31d3bf04a31946c203851e6d676_28).

<sup>3</sup> See, e.g., S&P Global Ratings, *Ameren Illinois Co.*, RatingsDirect (Apr. 27, 2020).

<sup>4</sup> S&P Global Ratings, *Louisville Gas & Electric Co.* (Mar. 16, 2020). Provided as Attachment 6 to Response to AG-KIUC 1-104.

Similarly, Moody's Investors Service noted that LG&E is in the midst of a capital investment program that "represents about 33% of LG&E's net book value . . ." <sup>5</sup> While Moody's observed that regulatory lag associated with these capital expenditures would be "somewhat moderated" by approved regulatory mechanisms, Moody's also noted that LG&E's financial profile would continue to weaken. Moody's also concluded that "LG&E has elevated carbon transition risk within the U.S. regulated utility sector because it is a vertically integrated utility that has large, fossil based generation capacity." <sup>6</sup> Moreover, as discussed in Mr. McKenzie's direct testimony, while the investment community views the regulatory mechanisms approved for LG&E to be supportive, they do not distinguish LG&E's risks from those of other utilities. <sup>7</sup>

For 2020, RRA Regulatory Focus reported an average ROE for electric distribution utilities of 9.10% versus 9.55% for vertically integrated electric utilities such as LG&E. Considering the distinctions in risks attributable to LG&E's integrated electric utility operations, as well as the case-specific factors enumerated above, reported ROEs for "wires-only" utilities do not serve as an appropriate benchmark to evaluate a fair ROE in this proceeding.

---

<sup>5</sup> Moody's Investors Service, *Louisville Gas & Electric Company*, Credit Opinion (Oct. 23, 2020). Provided as Attachment 3 to Response to AG-KIUC 1-104.

<sup>6</sup> *Id.*

<sup>7</sup> McKenzie Direct at 28-32; Exhibit AMM-3.

**LOUISVILLE GAS AND ELECTRIC COMPANY**

**Response to Commission Staff's Fifth Request for Information  
Dated March 19, 2021**

**Case No. 2020-00350**

**Question No. 4**

**Responding Witness: Lonnie E. Bellar / Robert M. Conroy**

- Q-4. Refer to the Direct Testimony of Lonnie E. Bellar (Bellar Testimony), Exhibit LEB-2, pages 8–9 of 16 and TFS2020–00270.<sup>8</sup>

Explain why the document reflecting planned capacity retirements and additions filed with the tariff filing did not reflect the retirements and additions contained in Exhibit LEB-2, Tables 2–5.

- A-4. Attachment 2 to the TFS2020-00270 filing only reflected the planned retirement of the Zorn CT in 2021 as it was the only retirement that the Companies had planned at the time of the filing in May 2020. The tables in LEB-2 reflect the retirements and capacity additions that were assumed after the TFS2020–00270 filing. See the response to Question No. 1.

The Companies continuously evaluate and update their assumptions and plans to reflect current and forecasted conditions as warranted for maintaining the system to deliver safe, reliable, and low-cost power to their customers. Because the tariff period relevant to the TFS2020-00270 is July 2020 through June 2022, these differences in assumptions had no impact on the calculation of the tariff rates.

---

<sup>8</sup> TFS2020-00270, Louisville Gas & Electric Company revised tariff updating the Purchase Rates for Small Capacity Co-generation and Small Power Production Qualifying Facilities (SQF), (filed May 28, 2020).

**LOUISVILLE GAS AND ELECTRIC COMPANY**

**Response to Commission Staff's Fifth Request for Information  
Dated March 19, 2021**

**Case No. 2020-00350**

**Question No. 5**

**Responding Witness: Lonnie E. Bellar**

- Q-5. Refer to the Bellar Testimony, Exhibit LEB-2, page 9 of 16. Confirm that LG&E plans to add two combustion turbines in 2028 and that this is the only planned generation addition.
- A-5. Confirmed but only in the context of Exhibit LEB-2. See the response to PSC 3-5 and Exhibit LEB-2 at page 7. For purposes of the analysis in Exhibit LEB-2, the Companies assumed that Mill Creek Unit 2 and Brown Unit 3 would be replaced with capacity from simple-cycle combustion turbines ("CTs") to create a generation portfolio that is minimally compliant for reliability, obviating the need to consider a range of fuel prices or a range of potential replacement alternatives. The point of this study was not to identify a potentially optimal future portfolio, but to determine whether the existing retirement years are reasonable and if not to determine reasonable retirement years based on current information. The study demonstrates that the proposed retirement years are reasonable even when potential energy-related benefits from other types of resources (e.g., renewables and natural gas combined cycle) are ignored.

The Companies have issued a request for proposals for potential actual generation replacement alternatives. The Companies will evaluate the energy and capacity benefits of these proposals along with self-build alternatives to determine an optimal future generation portfolio. In addition, the Companies will file their 2021 Integrated Resource Plan in October 2021.

**LOUISVILLE GAS AND ELECTRIC COMPANY**

**Response to Commission Staff's Fifth Request for Information  
Dated March 19, 2021**

**Case No. 2020-00350**

**Question No. 6**

**Responding Witness: Lonnie E. Bellar**

- Q-6. Refer to the Bellar Testimony, Exhibit LEB-2, page 10 of 16. For Mill Creek Unit 2, provide the average environmental compliance costs per MW of capacity.
- A-6. The estimated cost of SCR for Mill Creek Unit 2 is \$455,000 per MW in 2020 dollars. This cost is computed as the quotient of the estimated SCR capital cost (\$135 million) and Mill Creek Unit 2's net summer rating (297 MW). As such, the cost excludes other environmental compliance costs in the unit's existing stay-open costs.

**LOUISVILLE GAS AND ELECTRIC COMPANY**

**Response to Commission Staff's Fifth Request for Information  
Dated March 19, 2021**

**Case No. 2020-00350**

**Question No. 7**

**Responding Witness: Lonnie E. Bellar / Kent W. Blake**

- Q-7. Regarding the proposed AMI project, provide responses to the following items.
- a. Explain in detail why LG&E considers its existing non-AMI meters to be obsolete.
  - b. State whether LG&E is willing to guarantee the level of benefits as set forth in the economic analysis will inure to its customers.
  - c. If approved, state whether LG&E is willing to implement a floor in connection with the establishment of any regulatory liabilities which floor would equal the amount of the benefits that were projected in KU's economic analysis.
  - d. If approved, state whether LG&E is willing to implement a ceiling in connection with the establishment of any regulatory assets which ceiling would equal the amount of the capital cost of the AMI project as estimated in KU's economic analysis.
- A-7.
- a. As stated in Bellar's direct testimony at page 60, the Companies have looked thoroughly at the issue of whether existing electric meters are obsolete and have determined that 734,000 of the Companies' 1,008,000 electric meters are electromechanical, obsolete, and are no longer being manufactured. Table 2 on page 7 of Exhibit LEB-3 Analysis of Metering Alternatives provides a summary of the Companies' meter assets. The Companies issued a request for information in March 2020 to gather information from meter vendors regarding the future availability and pricing for various meter types. All respondents stated that electromechanical meters are no longer manufactured (see Appendix B – Metering RFI Summary to Exhibit LEB-3). In the Status Quo metering alternative, electromechanical meters are replaced as they fail with non-communicating electronic meters.



Pages 3-4 and 17-19 of Exhibit LEB-3 explain how the analysis evaluates Automatic Meter Reading obsolescence risk. The impact of this risk on the cost benefit analysis is shown in Table 1 at page 4.

- b. No. The Companies do not believe such a guaranty is necessary, appropriate or consistent with regulatory precedent in Kentucky. It is not necessary since the Companies are not seeking to incorporate the AMI project into rates in this proceeding. The Companies have proposed to defer all rate impacts of the AMI project until it is completed. At that time, all costs will be known, and all monetary benefits, except for those already flowing through the Companies' fuel adjustment clause, will be included in the Companies' rates at that time if any change thereto is needed. Such a guaranty is also not appropriate given the fact that externalities beyond the Companies control could cause costs and benefits to vary from those currently projected in the Companies' cost-benefit analyses. The Companies continue to believe that the costs and benefits projected in its current analysis are reasonable and likely conservative, as noted by certain intervenors in this proceeding. When the AMI project is incorporated into base rates, the Commission and other parties will be able to review the actual costs, as well as current and projected benefits at that time. The Companies acknowledge that, should actual costs be significantly greater or benefits be significantly less than those included in the Companies' current cost-benefit analyses in this proceeding, such variations will be scrutinized and the Companies must be able to support the prudence of their actions and reasonableness of investment. Finally, the Companies do not believe such a guaranty is consistent with regulatory precedent in Kentucky. LG&E acknowledges and accepts that the authorization of the AMI project by the approval of the AMI ratemaking proposal and the issuance of the certificate of public convenience and necessity does not guarantee cost recovery of the AMI project costs. Consequently, LG&E cannot promise with unconditional certainty or guarantee the level of benefits as set forth in the economic analysis will inure to its customers. Guaranteeing the level of benefits is not consistent with the risk, and thus the return, associated with the regulatory compact for prudent investments.
- c. No. See the response to part b. In addition, such an asymmetrical condition whereby a certain level of benefits are guaranteed with any incremental benefits being provided to customers and any shortfall of achieving benefits relative to those projected at the start of the project are absorbed by the utility is not consistent with the Companies' efforts to bring the benefits outlined in the testimonies of Mr. Bellar, Ms. Saunders and Mr. Wolfe to customers in an innovative manner with the Companies having already proposed to carry the net costs in the early years until they are offset by the cumulative monetary benefits of the project such that, based on the Companies' current projections, will never result in an increase in the Companies' combined revenue

requirement. The Companies would expect to consider actual costs, projected benefits, allocations, as well as regulatory asset and liability balances in their next base rate proceedings following full AMI deployment to optimize cost recovery for the benefit of LG&E and KU customers at that time. Optimizing these benefits on an individual utility basis will likely require different amortization periods between LG&E and KU in their next rate cases to account for differences in the revenue requirements certain years with offsetting reductions in the revenue requirements in those same years. In approving the ratemaking proposal set forth in Mr. Blake's direct testimony, the Commission is not foregoing its authority to review the costs, regulatory assets and regulatory liabilities for ratemaking purposes in the next base rate case.

- d. No. See the response to parts b and c. Just to clarify, the Companies have not proposed to record the capital costs of the project as a regulatory asset but rather will record such costs as Construction Work in Progress (CWIP). The proposed regulatory assets requested were limited to (1) operating expenses associated with the projection implementation; (2) the remaining net book value of electric meters to be replaced and retired as part of this project; and (3) the difference between AFUDC accrued at the Companies' weighted average cost of capital and that calculated using a strict interpretation of the FERC methodology. As shown in Exhibit KWB-1 in the Blake direct testimony, the combination of those three are projected to be significantly less than the projected capital costs to be recorded in CWIP.

**LOUISVILLE GAS AND ELECTRIC COMPANY**

**Response to Commission Staff's Fifth Request for Information  
Dated March 19, 2021**

**Case No. 2020-00350**

**Question No. 8**

**Responding Witness: Eileen L. Saunders**

- Q-8. Refer to LG&E's Response to Commission Staff's Third Request for Information, Item 9, which discussed disconnections and reconnections. For the past two calendar years and for the year to date, provide the following:
- a. The percentage of disconnection/reconnections performed by contract labor;
  - b. The percentage of disconnection/reconnections performed by employees; and
  - c. The percentage of disconnection/reconnections performed after hours.

A-8.

a. - c. Percentage of Disconnection/Reconnections Performed

	<u>2019</u>	<u>2020</u>	<u>2021 Feb YTD</u>
a. By Contractors	92%	71%	90%
b. By Employees	8%	29%	10%
c. After Hours	17%	21%	4%

Note: Moratorium on disconnections March 16, 2020 through October 20, 2020. Non-residential disconnects resumed on November 12, 2020. Residential disconnects remain suspended.

**LOUISVILLE GAS AND ELECTRIC COMPANY**

**Response to Commission Staff's Fifth Request for Information**  
**Dated March 19, 2021**

**Case No. 2020-00350**

**Question No. 9**

**Responding Witness: Eileen L. Saunders**

Q-9. Refer to LG&E's Response to Commission Staff's Third Request for Information, Item 22, which explains that increases or decreases in the number of disconnect and reconnects would result in increased or decreased contract labor expense.

- a. Explain whether LG&E experienced a decrease in contract labor expenses during the moratorium on disconnections or whether the contract laborers that would normally perform those services were repurposed to other tasks.
- b. Explain whether LG&E experienced a decrease in employee labor expenses during the moratorium on disconnections or whether the employees that would normally perform those services were repurposed to other tasks.

A-9.

- a. The Company experienced contract labor savings of approximately \$435,000 in the base year which accounts for less overtime, some vacancies, and some repurposed contractors during the moratorium due to the Covid19 pandemic conditions. Contractors used to perform disconnects also normally perform other customer service order related tasks. During the moratorium, contractors continued to perform other customer service order related tasks and some were repurposed to perform other duties within the Company in the gas meter shop. PPE protocol was enhanced due to the pandemic which lengthened the time to complete certain work types, particularly those inside customer premises. The conditions in the base year are an anomaly and not the forecast test period, and do not represent a recurring level of expense going forward.
- b. The Company maintained the same level of employees during the moratorium but some overtime savings of \$214,601 in the base year were realized due to the Covid19 pandemic conditions. Company employees who perform disconnects also normally perform other customer service order related tasks. During the moratorium, Company employees continued to perform other customer service order related tasks and were not repurposed to perform other tasks within the Company. PPE protocol was enhanced due to the pandemic

which lengthened the time to complete certain work types, particularly those inside customer premises. The conditions in the base year are an anomaly and not the forecast test period, and do not represent a recurring level of expense going forward.

**LOUISVILLE GAS AND ELECTRIC COMPANY**

**Response to Commission Staff's Fifth Request for Information  
Dated March 19, 2021**

**Case No. 2020-00350**

**Question No. 10**

**Responding Witness: Eileen L. Saunders**

- Q-10. Refer LG&E's Response to Metropolitan Housing Coalition, Kentuckians for the Commonwealth, and Kentucky Solar Energy Society's Second Request for Information, Item 2(d), which explains that, from March 16, 2020, through December 31, 2020, LG&E tracked the number of customers who would have been assessed a late fee on their bill if not for the moratorium on late payment fees. For 2018 through present, provide the percentage of customers, broken down by year, month, and class of customer, who were charged a late payment fee. From March 16, 2020, through December 31, 2020, the percentage included should reflect the percentage of customers who would have been charged a late payment fee if not for the moratorium on late payment fees.
- A-10. See attached. From March 2020 through December 2020 the percentages in the attached reflect the customers that would have incurred a late payment charge. However, it cannot be determined from the data in the attachment whether the incurrence of the late payment charge is due to the moratorium on the imposition of a late payment charge or the moratorium on disconnection due to non-payment. The moratoriums on assessing late payment fees and on disconnections impacted LG&E's accounts receivables for the past year. Since March 13, 2020, past due amounts have increased by about \$21 million of which 60 days past due have increased by about \$17 million. The total accounts receivable are now \$27 million above the March 13, 2020 level. Current balances account for approximately 76% of the Company total accounts receivable balance versus 89% at March 13, 2020.

Louisville Gas and Electric  
January 2018 through February 2021

Percentage of Customers with Late Payment Charge

<u>2018</u>	<u>January</u>	<u>February</u>	<u>March</u>	<u>April</u>	<u>May</u>	<u>June</u>	<u>July</u>	<u>August</u>	<u>September</u>	<u>October</u>	<u>November</u>	<u>December</u>
Commercial	9%	10%	7%	7%	8%	8%	9%	9%	7%	8%	7%	7%
Industrial	5%	8%	4%	6%	4%	5%	6%	6%	4%	5%	5%	5%
Public Authority	1%	1%	1%	1%	1%	1%	2%	1%	1%	1%	1%	1%
Residential	18%	18%	11%	12%	15%	14%	17%	18%	12%	15%	12%	12%
<u>2019</u>	<u>January</u>	<u>February</u>	<u>March</u>	<u>April</u>	<u>May</u>	<u>June</u>	<u>July</u>	<u>August</u>	<u>September</u>	<u>October</u>	<u>November</u>	<u>December</u>
Commercial	8%	8%	8%	6%	7%	7%	9%	9%	6%	7%	7%	8%
Industrial	5%	6%	5%	4%	5%	7%	8%	6%	4%	6%	7%	9%
Public Authority	2%	1%	1%	1%	1%	1%	1%	1%	1%	1%	1%	1%
Residential	17%	15%	14%	11%	11%	13%	17%	20%	13%	15%	11%	12%
<u>2020</u>	<u>January</u>	<u>February</u>	<u>March</u>	<u>April</u>	<u>May</u>	<u>June</u>	<u>July</u>	<u>August</u>	<u>September</u>	<u>October</u>	<u>November</u>	<u>December</u>
Commercial	8%	7%	11%	16%	14%	14%	14%	16%	15%	14%	11%	9%
Industrial	6%	5%	6%	8%	9%	7%	8%	7%	11%	6%	6%	7%
Public Authority	1%	1%	1%	2%	1%	4%	5%	8%	9%	2%	3%	2%
Residential	17%	14%	16%	14%	11%	14%	17%	19%	17%	17%	12%	18%
<u>2021</u>	<u>January</u>	<u>February</u>										
Commercial	10%	9%										
Industrial	11%	8%										
Public Authority	2%	1%										
Residential	16%	18%										

\*From March 16, 2020, through December 31, 2020, the percentage included reflects the customers who would have been charged a late payment charge if there had not been a moratorium

**LOUISVILLE GAS AND ELECTRIC COMPANY**

**Response to Commission Staff's Fifth Request for Information  
Dated March 19, 2021**

**Case No. 2020-00350**

**Question No. 11**

**Responding Witness: Lonnie E. Bellar / Robert M. Conroy**

Q-11. Refer to LG&E's Response to Commission Staff's Third Request for Information, Item 44(a), which explains the circumstances under which LG&E foresees it would use vaporized liquefied petroleum gas and air and liquefied natural gas to supplement its gas supply.

- a. Given that LG&E has not developed any scenarios, volumes, or costs for a propane air plant because a propane air plant is not flexible enough to be used in a variety of supply requirement scenarios and locations, explain why it is reasonable for LG&E's tariff to contain a provision allowing it to supplement its supply of natural gas with a mixture of vaporized liquefied petroleum gas and air.
- b. Regarding liquefied natural gas, indicate the type of demand-like or set-up facility charges that would be associated with liquefied natural gas and indicate whether LG&E has any immediate plans to incur that kind of cost in order to meet a "just in case" situation.

A-11.

- a. LG&E's gas tariff has for many decades included language regarding the right to supplement LG&E's supply of natural gas with a mixture of vaporized liquefied petroleum gas and air. This language is consistent with the tariffs of Atmos Energy and Delta Natural Gas. Furthermore, LG&E believes that such language was incorporated into the Commission's regulations but has been recently removed. Having the language regarding the right to supplement LG&E's supply of natural gas with a mixture of vaporized liquefied petroleum gas and air in the tariff now gives the Company the flexibility to utilize this source in the future should it provide lower costs to customers.
- b. In its response to Question No. 44 of Commission Data Request No. 3, LG&E described a scenario to meet customers' firm gas supply requirements during a peaking situation requiring an equivalent of about 2,600 Mcf over the course of five (5) days with an estimated cost of \$166,000. In this particular scenario, the demand cost component was estimated to be about \$27,000. The payment



of these demand-like reservation fees would ensure that LG&E has access to a specified service level for a defined term (*i.e.*, for a term of three (3) months for up to 500 Mcf/hour). LG&E has no immediate plans to incur LNG-related costs in order to meet a “just in case” situation. LG&E’s plans (immediate or otherwise) to incur LNG-related costs are subject to the on-going assessments of the reliability needs of its gas system and the use of LNG-based solutions pending the Commission’s approval of the proposed tariff language.

**LOUISVILLE GAS AND ELECTRIC COMPANY**

**Response to Commission Staff's Fifth Request for Information**  
**Dated March 19, 2021**

**Case No. 2020-00350**

**Question No. 12**

**Responding Witness: Lonnie E. Bellar**

Q-12. Regarding the Bullitt County gas pipeline, provide responses to the following items.

- a. Provide an update on the projected capital cost to construct the pipeline as well as a break-out of the estimated capital costs.
- b. State whether there are any amounts associated with cost in aid of construction will be applied towards the capital cost of the Bullitt Count gas pipeline project. If so, provide a break-out of those amounts and the associated entities that will be providing those costs.
- c. Provide the names and addresses of the 400 potential customers that have been denied gas service due to lack of gas service in the area that the Bullitt County gas pipeline will be providing gas service.
- d. Out of those 400 potential customers, state when the first potential customer was denied gas service.
- e. Provide the annual throughput for the last seven years of the gas pipelines in the area where the Bullitt Count Pipeline project is to be constructed.

A-12.

- a. The current project estimate is \$74.2 million. See breakout in the table below.

Category	Estimated Cost (\$ million)
Real Estate and Right of Way	\$4.10
Material	\$5.00
Contract Labor	\$62.70
Company Labor	\$1.70
Miscellaneous	\$0.70

**The project estimate does contain contingency.**

- b. Because of the need to reinforce the infrastructure in Bullitt County due to the dependency of thousands of customers on the existing primary feed to the area, and the capacity constraints affecting the area, there are no costs in aid of construction that will be applied towards the capital costs.
- c. See attached. The information requested is confidential and proprietary and is being provided under seal pursuant to a petition for confidential protection.
- d. The first deferral was in May 2019.
- e. While LG&E measures the real time pressure of gas flowing into the pipelines within the Bullitt County Pipeline project area for operational purposes, the gas flows associated with those pressure measurements are not measured. The growth in the design day model peak hour projections in Bullitt County has resulted in denials of service due to inability to meet minimum design pressures. The proposed pipeline project will mitigate this issue in addition to increasing reliability of the system for existing customers by adding a second high-pressure supply of gas to the area.

Gas system models are developed annually prior to the upcoming winter operating season utilizing Synergi Gas, LG&E’s hydraulic modeling and simulation software. The table below provides the projected peak hourly load and annual percent change for a design day in Bullitt County for the past 8 winter operating seasons. The software generates a load file for the entire model using rolling 3-year meter reads and weather data to determine customer base loads and then applies correction factors for the desired temperature day of the model. This is done for all customers except for firm transport customers which have loads that are typically process driven and accounted for in the model load file based on actual flow data.

Winter Operating Season	Design Day Peak Hour Load (mcfh)	Design Day Peak Hour Load increase (%)
2013-2014	1,271	
2014 -2015	1,390	9.36%
2015 -2016	1,461	5.09%
2016 -2017	1,468	0.49%
2017-2018	1,475	0.49%
2018 -2019	1,535	4.05%
2019 -2020	1,610	4.89%
2020 -2021	1,540	-4.36%

As shown in the table above, Bullitt County experienced a projected design day peak hour growth of over 26% between the 2013 – 2014 winter operating season and the 2019 – 2020 winter operating season with a compound annual

growth rate (CAGR) of 3.43%. The decrease in projected design day load in the 2020 – 2021 model is attributed to reduced commercial and industrial customer operations during the COVID 19 pandemic and not expected to be a permanent load reduction. Including the 2020 – 2021 projected design day peak hour load the increase from the 2013 – 2014 winter operating season was about 21% with a CAGR of 2.43%.

The entire attachment is  
Confidential and  
provided separately  
under seal.

**LOUISVILLE GAS AND ELECTRIC COMPANY**

**Response to Commission Staff's Fifth Request for Information  
Dated March 19, 2021**

**Case No. 2020-00350**

**Question No. 13**

**Responding Witness: William Steven Seelye**

- Q-13. The percentage increase to the base demand charge for rate classes TODS, TODP, RTS, and FLS is increased significantly as compared to the percentage increases proposed for the energy charge and intermediate and peak demand components. Provide an explanation for this proposed rate design.
- A-13. The increases in both the demand charges and energy charges are based on the results from the Companies' cost of service studies. The energy charges for TODS, TODP, RTS, and FLS were derived from the energy-related costs calculated in the Companies' cost of service studies. Most of the increased revenue requirements reflected in the cost of service studies reflect increases in fixed costs, which for TODS, TODP, RTS, and FLS are predominantly recovered through the demand charges, with distribution and transmission costs recovered through the base demand charge increasing by greater percentages. Energy-related costs have not increased as much as demand-related costs, particularly distribution and transmission costs.

**LOUISVILLE GAS AND ELECTRIC COMPANY**

**Response to Commission Staff's Fifth Request for Information  
Dated March 19, 2021**

**Case No. 2020-00350**

**Question No. 14**

**Responding Witness: Kent W. Blake / Robert M. Conroy**

- Q-14. Refer to the Direct Testimony of Kent W. Blake in Case No. 2017-00415.<sup>9</sup> Provide an update of Exhibit KWB-1 for each of the years 2018, 2019, and 2020.
- A-14. See attached. The attachments show that the average residential rate difference between KU and LG&E has increased slightly since the referenced exhibit was prepared in Case No. 2017-00415. Consequently, the conclusion remains the same that a significant level of annual savings (north of \$28 million in 2020 per the attached calculation) from a legal entity merger would be required to put the two residential customer bases on the same rate while avoiding an increase for either (that being KU since it continues to have the lower average residential rate).

---

<sup>9</sup> Case No. 2017-00415, Electronic Joint Application of PPL Corporation, PPL Subsidiary Holdings, LLC, PPL Energy Holdings, LLC, LG&E and KU Energy LLC, Louisville Gas and Electric Company and Kentucky Utilities Company for Approval of an Indirect Change of Control of Louisville Gas and Electric Company and Kentucky Utilities Company (filed Mar. 13, 2018).

Residential Class - 12 months ending December 31, 2018

		( A ) LG&E	( B ) KU	( C ) Combined
(1)	No. Customer Months	4,345,344	5,179,416	9,524,760
(2)	Energy Consumption (kWh)	4,370,390,818	6,320,045,976	10,690,436,794
(3)	Residential Revenue	\$451,172,021	\$612,929,492	\$1,064,101,513
(4)				
(5)	Average Rate (\$/kWh)	(3) / (2)	\$0.1032	\$0.0970
(6)	Average Monthly Usage (kWh)	(2) / (1)	1,006	1,220
(7)	Average Monthly Bill	(5) x (6)	\$103.83	\$118.34
(8)				
(9)	Combined Rate:	(5), col ( C )	\$0.0995	\$0.0995
(10)	Average Bill	(9) x (6)	\$100.11	\$121.46
(11)	Customer Impact	(10) - (7)	(\$3.72)	\$3.12
(12)				
(13)				
(14)	Maintain No Increase:			
(15)	Average Rate (\$/kWh)	(5), col ( B )	\$0.0970	\$0.0970
(16)	Average Bill	(15) x (6)	\$97.54	\$118.34
(17)	Total Revenue	(15) x (2)	\$423,848,408	\$612,929,492
(18)	Savings Required to Achieve	(17) - (3)	(\$27,323,613)	\$0
				\$1,036,777,900
				(\$27,323,613)

Source: LG&E and KU Monthly Financial Reports and Revenue Volume Analysis Reports



Residential Class - 12 months ending December 31, 2019

		( A ) LG&E	( B ) KU	( C ) Combined
(1)	No. Customer Months	4,390,920	5,212,488	9,603,408
(2)	Energy Consumption (kWh)	4,229,047,796	6,080,135,788	10,309,183,584
(3)	Residential Revenue	\$460,595,502	\$620,789,920	\$1,081,385,422
(4)				
(5)	Average Rate (\$/kWh)	(3) / (2)	\$0.1089	\$0.1021
(6)	Average Monthly Usage (kWh)	(2) / (1)	963	1,166
(7)	Average Monthly Bill	(5) x (6)	\$104.90	\$119.10
(8)				
(9)	Combined Rate:	(5), col ( C )	\$0.1049	\$0.1049
(10)	Average Bill	(9) x (6)	\$101.03	\$122.36
(11)	Customer Impact	(10) - (7)	(\$3.87)	\$3.26
(12)				
(13)				
(14)	Maintain No Increase:			
(15)	Average Rate (\$/kWh)	(5), col ( B )	\$0.1021	\$0.1021
(16)	Average Bill	(15) x (6)	\$98.34	\$119.10
(17)	Total Revenue	(15) x (2)	\$431,791,383	\$620,789,920
(18)	Savings Required to Achieve	(17) - (3)	(\$28,804,119)	\$0
				\$1,052,581,303
				(\$28,804,119)

Source: LG&E and KU Monthly Financial Reports and Revenue Volume Analysis Reports

Residential Class - 12 months ending December 31, 2020

		( A ) LG&E	( B ) KU	( C ) Combined
(1)	No. Customer Months	4,455,600	5,262,444	9,718,044
(2)	Energy Consumption (kWh)	4,122,472,974	5,968,339,429	10,090,812,403
(3)	Residential Revenue	\$465,439,678	\$632,660,966	\$1,098,100,644
(4)				
(5)	Average Rate (\$/kWh)	(3) / (2)	\$0.1129	\$0.1060
(6)	Average Monthly Usage (kWh)	(2) / (1)	925	1,134
(7)	Average Monthly Bill	(5) x (6)	\$104.46	\$120.22
(8)				
(9)	Combined Rate:	(5), col ( C )	\$0.1088	\$0.1088
(10)	Average Bill	(9) x (6)	\$100.69	\$123.42
(11)	Customer Impact	(10) - (7)	(\$3.78)	\$3.20
(12)				
(13)				
(14)	Maintain No Increase:			
(15)	Average Rate (\$/kWh)	(5), col ( B )	\$0.1060	\$0.1060
(16)	Average Bill	(15) x (6)	\$98.08	\$120.22
(17)	Total Revenue	(15) x (2)	\$436,993,868	\$632,660,966
(18)	Savings Required to Achieve	(17) - (3)	(\$28,445,810)	\$0
				(\$28,445,810)

Source: LG&E and KU Monthly Financial Reports and Revenue Volume Analysis Reports

**LOUISVILLE GAS AND ELECTRIC COMPANY**

**Response to Commission Staff's Fifth Request for Information**  
**Dated March 19, 2021**

**Case No. 2020-00350**

**Question No. 15**

**Responding Witness: Robert M. Conroy**

- Q-15. Refer to the Direct Testimony of William Steven Seelye (Seelye Testimony), page 43, lines 11–12.
- a. State when the avoided cost calculation methodology for Rider SQF was most recently approved.
  - b. Provide a citation to the Order approving the avoided cost methodology.
  - c. Provide the avoided cost data and workpapers associated with the Rider SQF rate and the testimony explaining and supporting the methodology.
- A-15. The Company has made biennial filings with the Commission to update SQF rates in accordance with 807 KAR 5:054 Section 5 since the Commission initially approved SQF rates in 1984 in Case No. 8566.<sup>10</sup> The Company's method for calculating SQF rates has used the avoided cost approach since the inception of Rider SQF.
- a. The most recent Commission order approving the Company's SQF methodology was the Commission's August 24, 2004 order in Case No. 2004-00201. A copy of the order is attached.

The Commission issued its most recent acceptance of the Company's SQF rates, which occurred following a number of questions from the Commission's tariff branch, less than a year ago on June 30, 2020. A copy of the correspondence between the Company and the Commission's tariff branch is attached. (The attachments to the June 22, 2020 email have been omitted because the Company provided them in response to AG-KIUC 1-172.) Also attached is a copy of the June 30, 2020 letter from the Executive Director of the Commission stating that the Company's updated SQF rates had been received and reviewed and attaching the accepted tariff page with the Company's proposed SQF rates.

---

<sup>10</sup> *Setting Rates and Terms and Conditions of Purchase of Electric Power from Small Power Producers and Cogenerators by Regulated Electric Utilities*, Case No. 8566, Order (Ky. PSC June 28, 1984).

- b. See the response to part a.
- c. See the response to AG-KIUC 1-172 regarding the Commission's most recent acceptance of the Company's SQF rates. See attached regarding information the Company provided to the Commission in Case No. 2004-00201.

COMMONWEALTH OF KENTUCKY  
BEFORE THE PUBLIC SERVICE COMMISSION

In the Matter of:

THE TARIFF FILING OF KENTUCKY	)	
UTILITIES COMPANY TO REVISE RATES	)	CASE NO. 2004-00200
FOR SMALL POWER PRODUCTION AND	)	
COGENERATION	)	

THE TARIFF FILING OF LOUISVILLE GAS	)	
AND ELECTRIC COMPANY TO REVISE	)	CASE NO. 2004-00201
RATES FOR SMALL POWER PRODUCTION	)	
AND COGENERATION	)	

O R D E R

On May 14, 2004, Kentucky Utilities Company ("KU") and Louisville Gas and Electric Company ("LG&E") filed identical proposed changes to their tariffs for the purchase of electricity from small power production and cogeneration facilities, to be effective June 14, 2004. On June 3, 2004, the Commission issued an Order suspending the proposed tariffs for one day, allowing them to become effective subject to refund on June 15, 2004, and requesting additional information. LG&E and KU responded to the request for additional information, as well as to a subsequent request for information. The case now stands submitted for decision.

The proposed tariffs include increased avoided cost rates to be paid during each of the three billing periods contained therein. During the summer peak billing periods, the payment rates will increase from 1.843 to 3.124 cents per kWh; during the winter peak billing periods, they will increase from 1.683 to 1.922 cents per kWh; and during off-peak periods, they will increase from 1.515 to 1.802 cents per kWh. KU and LG&E used their PROSYM hourly production model results to develop these avoided cost

rates based on: (1) the costs of the most recent combustion turbines ("CT") installed on their combined systems; (2) the projected cost of a potential second coal-fired unit at LG&E's Trimble County Generating Station; and (3) the projected cost of a Greenfield CT, forecast to be installed in 2013.

Based on a review of the revised tariffs and the documentation supporting the increased payment rates, the Commission finds that the proposed tariffs for payments to small power production and cogeneration facilities are reasonable and should be approved effective with the date of this Order. Since the rates being approved today are the same as those previously authorized to be effective subject to refund, no refunds are necessary.

IT IS THEREFORE ORDERED that:

1. KU's and LG&E's proposed changes to their small power production and cogeneration tariffs are approved effective with the date of this Order, and no refunds are necessary for the period during which these rates were effective subject to refund.

2. Within 20 days of the date of this Order, KU and LG&E shall file their revised small power production and cogeneration tariffs that show the date issued and that they were issued by authority of this Order.

Done at Frankfort, Kentucky, this 24<sup>th</sup> day of August, 2004.

By the Commission

ATTEST:

  
Executive Director

**From:** [Hornung, Mike](#)  
**To:** ["Hinton, Daniel E \(PSC\)"](#)  
**Cc:** [Sturgeon, Allyson](#); [Judd, Sara](#); [Lovekamp, Rick](#); [Hurst, Brian](#)  
**Subject:** RE: KY-PSC Electronic Filing Center NotificationTFS2020-00270  
**Date:** Wednesday, June 03, 2020 9:34:16 AM  
**Attachments:** [2020 Avoided Cost Filing Attachments.xlsx](#)

---

Daniel,

Please find the attached Excel spreadsheet that contains your requested information.

Please also note that the values held within are calculated from the Company's generation planning models to arrive at the Avoided Cost. As such, there are not any formulas embedded within this spreadsheet. The values are outputs from these models.

Lastly, please let us know if you need any further information.

Thanks,

**Michael E. Hornung**

Manager | Pricing & Tariffs | LG&E and KU

[REDACTED]

[REDACTED]

lge-ku.com

---

**From:** Hinton, Daniel E (PSC)  
**Sent:** Monday, June 01, 2020 12:18 PM  
**To:** Hornung, Mike  
**Subject:** RE: KY-PSC Electronic Filing Center NotificationTFS2020-00270

**EXTERNAL email. STOP and THINK before responding, clicking on links, or opening attachments.**

Mr. Hornung,

Does LG&E/KU have a spreadsheet (preferably in Excel) that supports Attachment 1 to these filings?

If so, could you please provide that?

Let me know if you have any questions.

Thanks.

Daniel

---

**From:** PSC - Tariffs [REDACTED]  
**Sent:** Thursday, May 28, 2020 12:33 PM  
**To:** Hinton, Daniel E (PSC) [REDACTED] Ripy, Zachary (PSC) [REDACTED]  
**Subject:** FW: KY-PSC Electronic Filing Center NotificationTFS2020-00270

---

**From:** KY Public Service Commission  
**Sent:** Thursday, May 28, 2020 12:33:24 PM (UTC-05:00) Eastern Time (US & Canada)  
**To:** [REDACTED]  
**Cc:** PSC - Tariffs  
**Subject:** KY-PSC Electronic Filing Center NotificationTFS2020-00270

This notification has been sent to you regarding your recent Tariff filing : TFS2020-00270 file(s) have been transmitted successfully.

Documents received for Tariff filing: TFS2020-00270 for Louisville Gas and Electric Company

5/28/2020 12:33:19 PM

File Summary:

File Name: 01\_-\_READ\_FIRST\_-\_2020\_Avoided\_Cost\_Filing\_Letter\_LGE.pdf

Description: Cover Letter

File Name: 02\_-\_2020\_Avoided\_Cost\_Filing\_Attachments\_LGE.pdf

Description: Support Document

File Name: 03\_-\_LGE\_Electric\_PSC\_No.\_12\_-\_eff\_06-30-2020\_-\_SQF.pdf

Description: Tariff

Thank you.



The attachment is being provided in a separate file in Excel format.

**From:** [Hornung, Mike](#)  
**To:** ["Hinton, Daniel E \(PSC\)"](#)  
**Cc:** [Ripy, Zachary \(PSC\)](#); [Sturgeon, Allyson](#); [Judd, Sara](#); [Conroy, Robert](#)  
**Subject:** RE: LG&E Tariff Filing 270  
**Date:** Monday, June 15, 2020 2:37:00 PM

---

Daniel,

Please see the following respond to your questions:

Staff has the following questions regarding tariff filing to revise its SQF tariff:

1. Refer to the Cover Letter.
  - a. Explain how producing an avoided cost for one megawatt (MW) instead of 100 MW better reflects the collective capacity LG&E's Small Capacity Cogeneration and Small Power Production Qualifying Facilities.
  - b. Explain how assuming the Small Capacity Cogeneration and Small Power Production Qualifying Facilities will have no impact on unit commitment better estimates the operational impact of these facilities on LG&E's system.
  - c. Explain how LG&E is revising its methodology to consider the two year period that rates will be in effect.
2. Provide a narrative explanation of the origin of the numbers in Attachment 1 and how they were calculated.
3. Provide an explanation of how the numbers in Attachment 2 are used in the calculation.

-----  
RESPONSE:

1.
  - a. LG&E and KU collectively have ten accounts that participate in each company's Small Capacity Cogeneration and Small Power Production Qualifying Facilities ("SQF") rider, totaling 683 kW. LG&E has one account, which is 73 kW. KU has nine accounts, totaling 610 kW. Because the collective capacity of these facilities is approximately one MW, the avoided cost for one MW provides a much better estimate of the actual avoided cost than the average avoided cost of 100 MW.
  - b. Because the collective size of LG&E's and KU's SQF customers is less than one MW and because all of the participating facilities are intermittent solar resources, the Companies would not modify the commitment of its generation fleet in any way to accommodate the as-available energy from these small resources. The Companies currently commit their generation fleet with the ability to allow for momentary changes in load that are much larger than the collective capacity of the SQFs. Therefore, the Companies would not recommit generation units based on the operation of the SQFs.
  - c. Historically, LG&E and KU have provided an avoided cost for the current calendar year in which the SQF rider rate is being updated (2020, for example). However, the rate is effective for a two-year period beginning in July of the current year (July 1, 2020 through June 30, 2022 in this case). Estimating the avoided cost for this two-year period results in a rate that is directly applicable to the full period and most accurately estimates the Companies' expected avoided cost over that period. The Companies' revised methodology calculates the avoided cost as the average hourly marginal cost by defined peak type over the two-year period in which the rates will be effective.
2. The Companies used their dispatch modeling software, PROSYM, to estimate the marginal cost for LG&E and KU's collective system on an hourly basis for the years 2020 through 2025. The avoided cost figures shown in Attachment 1 are the arithmetic averages of these hourly marginal costs, calculated for the hours in each specified time period (calendar years 2020 through 2025 and the two-year period beginning 7/2020) and for each specified peak period (summer peak, winter

peak, off-peak, and all hours).

3. Attachment 2 shows the Companies' planned capacity additions and retirements for the years 2020 through 2029. Such capacity changes could impact the avoided cost calculation by influencing the generation system's hourly marginal cost. Capacity additions would typically lower the system marginal cost by increasing the number of available resources. Capacity retirements would typically increase the system marginal cost by reducing the number of available resources. However, because the Companies currently have only one planned retirement, which is the small Zorn CT with a capacity of 14 MW and a capacity factor of almost zero, the impact of this retirement is negligible.

Please let me know if you have any follow up questions.

Thanks,

**Michael E. Hornung**

Manager | Pricing & Tariffs | LG&E and KU

[REDACTED]

[REDACTED]

lge-ku.com

---

**From:** Hinton, Daniel E (PSC)

**Sent:** Thursday, June 11, 2020 11:49 AM

**To:** Hornung, Mike

**Cc:** Ripy, Zachary (PSC)

**Subject:** LG&E Tariff Filing 270

**EXTERNAL email. STOP and THINK before responding, clicking on links, or opening attachments.**

Mr. Hornung,

Staff has the following questions regarding KU's tariff filing to revise its SQF tariff:

1. Refer to the Cover Letter.

a. Explain how producing an avoided cost for one megawatt (MW) instead of 100 MW better reflects the collective capacity LG&E's Small Capacity Cogeneration and Small Power Production Qualifying Facilities.

b. Explain how assuming the Small Capacity Cogeneration and Small Power Production Qualifying Facilities will have no impact on unit commitment better estimates the operational impact of these facilities on LG&E's system.

c. Explain how LG&E is revising its methodology to consider the two year period that rates will be in effect.

2. Provide a narrative explanation of the origin of the numbers in Attachment 1 and how they were calculated.

3. Provide an explanation of how the numbers in Attachment 2 are used in the calculation.

Responses can be emailed to us at this address. If you have any questions, please let me know.

Thanks.

Daniel

**From:** [Hornung, Mike](#)  
**To:** ["Hinton, Daniel E \(PSC\)"](#)  
**Cc:** [Sturgeon, Allyson](#); [Judd, Sara](#); [Conroy, Robert](#); [Sinclair, David](#); [Judd, Sara](#); [Wilson, Stuart](#); [Sebourn, Michael](#); [Hurst, Brian](#); [Hall, Jeremy](#)  
**Subject:** RE: KU/LG&E SQF Tariff Filings  
**Date:** Wednesday, June 24, 2020 4:22:19 PM

---

Daniel,

Please see the following in response to the Staff's question:

The following table shows the avoided cost by peak type for four methodologies, and demonstrates the impact of changing three variables – unit recommitment, applicable time period, and the size (MW) considered.

- Step 1 shows the avoided cost rates using the same methodology that the Companies have historically used.
- Step 2 shows the avoided cost rates from Step 1 but assuming that the SQFs will not alter unit commitment. This change more accurately reflects the impact of these intermittent solar facilities on the operation of Companies' generation fleet, which is committed to accommodate system fluctuations including those arising from intermittent resources.
- Step 3 shows the avoided cost rates from Step 2 but revising the time period to be the period in which the rates will be in effect (7/2020 – 6/2022). This change results in rates that are more directly applicable to the full effective period and most accurately estimates the Companies' forecasted avoided costs over that period.
- Step 4 shows avoided cost rates with the Companies' proposed methodology of using 1 MW instead of 100 MW. This change more accurately approximates the collective 0.7 MW of existing SQF participants.

<i>cents/kWh</i>	<b>Time Period</b>	<b>Summer Peak</b>	<b>Winter Peak</b>	<b>Off Peak</b>	<b>All Hours</b>
<b>(1) Prior Years' Method:</b> 100 MW with Unit Recommitment	2020	3.127	2.510	2.468	2.558
<b>(2) 100 MW without Unit Recommitment – 2020</b>	2020	2.222	2.161	1.983	2.035
<b>(3) 100 MW without Unit Recommitment – 2020-2022</b>	7/2020- 6/2022	2.257	2.224	2.033	2.083
<b>(4) Proposed Method:</b> 1 MW Marginal Cost, without unit recommitment	7/2020- 6/2022	2.282	2.236	2.145	2.173

Please let me know if you need anything else.

Thanks,

**Michael E. Hornung**

Manager | Pricing & Tariffs | LG&E and KU



lge-ku.com

---

**From:** Hinton, Daniel E (PSC)

**Sent:** Wednesday, June 24, 2020 10:46 AM

**To:** Hornung, Mike

**Subject:** RE: KU/LG&E SQF Tariff Filings

**EXTERNAL email. STOP and THINK before responding, clicking on links, or opening attachments.**

Mr. Hornung,

Can you provide the difference between using 1 MW vs 100 MW and indicate what the impact on avoided cost is?

The response can be emailed to me at this address.

Thanks.

Daniel

---

**From:** Hornung, Mike [REDACTED]  
**Sent:** Monday, June 22, 2020 4:42 PM  
**To:** Hinton, Daniel E (PSC) [REDACTED]  
**Cc:** Sturgeon, Allyson [REDACTED]; Conroy, Robert [REDACTED]  
[REDACTED] Sinclair, David [REDACTED]; Judd, Sara [REDACTED] Wilson,  
Stuart [REDACTED]; Sebourn, Michael [REDACTED]; Hurst,  
Brian [REDACTED] Hall, Jeremy [REDACTED]  
**Subject:** RE: KU/LG&E SQF Tariff Filings

Daniel,

Please find the attached documents in response to the Commission Staff's request below.

If upon review there are any other questions, please let me know.

Thanks,

**Michael E. Hornung**

Manager | Pricing & Tariffs | LG&E and KU

[REDACTED]  
[REDACTED]  
lge-ku.com

---

**From:** Hinton, Daniel E (PSC) <[REDACTED]>  
**Sent:** Thursday, June 18, 2020 11:12 AM  
**To:** Hornung, Mike <[REDACTED]>  
**Subject:** KU/LG&E SQF Tariff Filings

**EXTERNAL email. STOP and THINK before responding, clicking on links, or opening attachments.**

Mr. Hornung,

For the KU/LG&E SQF tariff filings, Staff has requested a narrative explanation of all assumptions, monthly fuel cost averages and yearly peak demand and peak generation, as well as a schedule summarizing the assumptions in a table format.

The information can be emailed to us at this address.

If you have any questions, please let us know.

Thanks.

Daniel

----- The information contained in this transmission is intended only for the person or entity to which it is directly addressed or copied. It may contain material of confidential and/or private nature. Any review, retransmission, dissemination or other use

of, or taking of any action in reliance upon, this information by persons or entities other than the intended recipient is not allowed. If you received this message and the information contained therein by error, please contact the sender and delete the material from your/any storage medium.

**From:** [Ripy, Zachary \(PSC\)](#)  
**To:** [Hornung, Mike](#)  
**Subject:** LGE and KU Energy Tariff Filing 2020-00270  
**Date:** Wednesday, July 01, 2020 12:35:15 AM  
**Attachments:** [03 - LGE Electric PSC No. 12 - eff 06-30-2020 - SQF.pdf](#)  
[TFS2020-00270.pdf](#)

---

**EXTERNAL email. STOP and THINK before responding, clicking on links, or opening attachments.**

RE: TFS-2020-00270

Mr. Hornung

Attached is the acceptance letter and stamped copy of the above referenced filing with the Kentucky PSC.

If you have any questions regarding this matter, please don't hesitate to call or contact us by email at [REDACTED]

Thanks,

Zach

**Zachary Ripy**

Public Utility Rate Analyst

Kentucky Public Service Commission

Andy Beshear  
Governor

Rebecca W. Goodman  
Secretary  
Energy and Environment Cabinet



Commonwealth of Kentucky  
**Public Service Commission**

211 Sower Blvd.  
P.O. Box 615  
Frankfort Kentucky 40602-0615  
Telephone: (502) 564-3940  
Fax: (502) 564-3460  
psc.ky.gov

July 1, 2020

Michael J. Schmitt  
Chairman  
**Conroy**

Robert Cicero  
Vice Chairman

Talina R. Mathews  
Commissioner

Michael E. Hornung  
LGE and KU Energy  
220 West Main St  
Louisville, KY 40202

RE: Filing No. **TFS2020-00270**  
Louisville Gas & Electric Company revised tariff updating the Purchase Rates for  
Small Capacity Co-generation and Small Power Production Qualifying Facilities.  
(SQF)

Dear Michael E. Hornung:

The above referenced filing has been received and reviewed. An accepted copy is enclosed for your files. You may also use the following link to access documents related to this filing.

<https://psc.ky.gov/trf4/TRFListFilings.aspx?ID=TFS2020-00270>

Sincerely,

A handwritten signature in blue ink, appearing to read "Kent A. Chandler".

Kent A. Chandler  
Executive Director



**Louisville Gas and Electric Company****Standard Rate Rider****SQF****Small Capacity Cogeneration and Small Power Production Qualifying Facilities****APPLICABLE**

In all territory served.

**AVAILABILITY**

This rate and the terms and conditions set out herein are available for and applicable to Company's purchases of energy only from the owner of qualifying cogeneration or small power production facilities of 100 kW or less (such owner being hereafter called "Seller") installed on Seller's property to provide all or part of its requirements of electrical energy, or from which facilities Seller may elect to sell to Company all or part of such output of electrical energy.

Company will permit Seller's generating facilities to operate in parallel with Company's system under conditions set out below under Parallel Operation.

Company will purchase such energy from Seller at the Rate, A or B, set out below and selected as hereafter provided, and under the terms and conditions stated herein. Company reserves the right to change the said Rates, upon proper filing with and acceptance by the jurisdictional Commission.

**RATE A: TIME-DIFFERENTIATED RATE**

- |  |                   |   |
|--|-------------------|---|
| 1. For summer billing months of June, July, August and September (on-peak hours) | \$0.02282 per kWh | R |
| 2. For winter billing months of December, January and February (on-peak hours)   | \$0.02236 per kWh | R |
| 3. During all other hours (off-peak hours)                                       | \$0.02145 per kWh | R |

On-peak hours for summer billing months of June through September are defined as weekdays (exclusive of holidays) from 8:01 A.M. to 9:00 P.M., Eastern Standard Time (under 1 above).

On-peak hours for winter billing months of December through February are defined as weekdays (exclusive of holidays) from 6:01 A.M. to 9:00 P.M., Eastern Standard Time (under 2 above).

Off-peak hours are defined as all hours other than those listed as on-peak (under 3 above).

Company reserves the right to change the hours designated as on-peak from time to time as conditions indicate to be appropriate.

**RATE B: NON-TIME-DIFFERENTIATED RATE**

For all kWh purchased by Company	\$0.02173 per kWh	R
----------------------------------	-------------------	---

**DATE OF ISSUE:** May 28, 2020

**DATE EFFECTIVE:** With Bills Rendered  
On and After June 30, 2020

**ISSUED BY:** /s/ Robert M. Conroy, Vice President  
State Regulation and Rates  
Louisville, Kentucky

**KENTUCKY  
PUBLIC SERVICE COMMISSION**

**Kent A. Chandler**  
Executive Director



EFFECTIVE

**6/30/2020**

PURSUANT TO 807 KAR 5:011 SECTION 9 (1)



LG&E Energy LLC  
220 West Main Street (40202)  
P.O. Box 32030  
Louisville, Kentucky 40232

June 18, 2004

Elizabeth O'Donnell, Executive Director  
Public Service Commission  
211 Sower Boulevard  
P. O. Box 615  
Frankfort, Kentucky 40601

RECEIVED

JUN 18 2004

PUBLIC SERVICE  
COMMISSION

***Re: TARIFF FILING OF KENTUCKY UTILITIES COMPANY  
TO REVISE RATES FOR SMALL POWER PRODUCTION  
AND COGENERATION – CASE NO. 2004-00200***

Dear Ms. O'Donnell:

Please find enclosed and accept for filing the original and ten (10) copies of the Response of Kentucky Utilities Company to the Information Requested in Appendix A of the Commission's Order Dated June 3, 2004, in the above-referenced matter.

Should you have any questions concerning the enclosed, please contact me at your convenience.

Sincerely,

A handwritten signature in black ink, appearing to read "John Wolfram". The signature is fluid and cursive.

John Wolfram  
Manager, Regulatory Affairs



**COMMONWEALTH OF KENTUCKY**  
**BEFORE THE PUBLIC SERVICE COMMISSION OF KENTUCKY**

**In the Matter of:**

**TARIFF FILING OF KENTUCKY UTILITIES )  
COMPANY TO REVISE RATES FOR SMALL ) CASE NO. 2004-00200  
POWER PRODUCTION AND COGENERATION )**

**RESPONSE TO  
INFORMATION REQUESTED IN  
APPENDIX A  
TO AN ORDER OF THE  
PUBLIC SERVICE COMMISSION  
DATED JUNE 3, 2004**

**FILED: JUNE 18, 2004**

**KENTUCKY UTILITIES COMPANY**

**CASE NO. 2004-00200**

**Response to Information Requested in Appendix A to an Order of the  
Public Service Commission Dated June 3, 2004**

**Question No. 1**

**Responding Witness: B. Keith Yocum**

Q1. Refer to Attachments 1 and 2 of KU's May 14, 2004 filing. Attachment 1 lists proposed avoided cost rates for different transaction quantities during different time periods. Attachment 2 shows planned generation additions and the projected per-unit capacity costs and fuel costs of the different additions.

- a. Provide a narrative description of how the per-unit capacity costs and energy costs shown in Attachment 2 were developed, along with the workpapers, calculations, spreadsheets, etc. that produce the cost levels shown therein.
- b. Provide a narrative description of how the avoided cost rates shown in Attachment 1 were derived. The description should fully explain how the per-unit costs in Attachment 2 are reflected in the avoided cost rates in Attachment 1. Include the workpapers, calculations, spreadsheets, etc. that show the derivation of these avoided cost rates.

A-1. a. Trimble Co. CT 7-10

- Capacity costs were developed using costs identified in Case No. 2002-00381 (CCN for TC 7-10) and expected unit net summer capacity.

$$\text{Capacity Cost} = \$227,392,000 / 155,000 \text{ kW} = \$367/\text{kW}$$

- Fuel cost was obtained from the Prosym hourly production model output.

$$\begin{aligned} \text{Fuel Cost} &= \text{Avg. Heat Rate (btu/kWh)} \times \text{Avg. Fuel Cost (cent/mmbtu)} \\ &= (11,004 \text{ btu/kWh} \times 547.5 \text{ cent/mmbtu}) / 1,000,000 \\ &= 6.02 \text{ cent/kWh} \end{aligned}$$

Trimble County 2

- The capacity cost was based on 75% of the most recent capital costs provided by Cummins & Barnard, Inc. (January 2004) and the Company's expected net summer capacity from the unit. The Cummins

- & Barnard estimate has been slightly modified to reflect updated capital requirements from 2003 to 2006.

$$\text{Capacity Cost} = \$769,955,625 / 549,000 \text{ kW} = \$1,402/\text{kW}$$

- The fuel cost was determined using its anticipated heat rate and coal prices for 2010.

$$\begin{aligned} \text{Fuel Cost} &= \text{Heat Rate (btu/kWh)} \times \text{Fuel Cost (cent/mmbtu)} \\ &= (8,703 \text{ btu/kWh} \times 132.8 \text{ cent/mmbtu}) / 1,000,000 \\ &= 1.16 \text{ cent/kWh} \end{aligned}$$

#### Greenfield CT

- The capacity cost was taken from KU/LG&E's 2002 IRP (Case No. 2002-00367 Volume III Section VIII. Supply Side Analysis) for a Simple Cycle GE 7FA CT and escalated to 2013 at a rate of 2.3%.

$$\text{Capacity Cost} = \$425/\text{kW} \times 1.023(2013-2002) = \$546/\text{kW}$$

- The fuel cost was determined using the heat rate also identified in the 2002 IRP and estimated 2013 gas prices.

$$\begin{aligned} \text{Fuel Cost} &= \text{Heat Rate (btu/kWh)} \times \text{Fuel Cost (cent/mmbtu)} \\ &= (11,500 \text{ btu/kWh} \times 631.1 \text{ cent/mmbtu}) / 1,000,000 \\ &= 7.26 \text{ cent/kWh} \end{aligned}$$

- b. The avoided cost rates shown in Attachment 1 are taken from Prosym hourly production model results. Avoided costs are determined via Prosym by looking at the last specified increments of load (100 MW in this case) and the cost of serving that load. Model results consist of fuel, O&M, and emission costs to serve the specified load - or costs avoided in not serving the load. Avoided fuel costs relating to Trimble Co. CT 7-10 will be included in the rates shown in Attachment 1 for all hours where their generation is in the specified MW increments (i.e. the last 100, 200, or 300 MW of power necessary to meet load requirements). A capacity component is not included in the costs identified in Attachment 1.

## 2004 Avoided Energy Cost Filing (cents/kWh)

Year: 2004				
Decremental MW Transaction	Summer Peak Period	Winter Peak Period	Off Peak Period	Average Day
100	3.124	1.922	1.802	1.987
200	2.966	1.859	1.710	1.890
300	2.556	1.674	1.562	1.704

Year: 2005				
Decremental MW Transaction	Summer Peak Period	Winter Peak Period	Off Peak Period	Average Day
100	3.121	1.795	1.887	2.038
200	2.863	1.980	1.769	1.935
300	2.586	1.684	1.624	1.756

Year: 2006				
Decremental MW Transaction	Summer Peak Period	Winter Peak Period	Off Peak Period	Average Day
100	3.472	1.910	1.863	2.076
200	3.259	1.974	1.716	1.943
300	2.848	1.813	1.638	1.813

Year: 2007				
Decremental MW Transaction	Summer Peak Period	Winter Peak Period	Off Peak Period	Average Day
100	3.837	2.225	2.048	2.296
200	3.502	1.936	1.904	2.112
300	3.102	1.745	1.768	1.936

Year: 2008				
Decremental MW Transaction	Summer Peak Period	Winter Peak Period	Off Peak Period	Average Day
100	3.918	2.277	2.140	2.385
200	3.761	2.152	2.021	2.260
300	3.347	1.990	1.859	2.066

Year: 2009				
Decremental MW Transaction	Summer Peak Period	Winter Peak Period	Off Peak Period	Average Day
100	4.342	2.947	2.499	2.790
200	4.089	2.750	2.356	2.626
300	3.690	2.304	2.107	2.336

## 2004 Avoided Energy Cost Filing

### Plans for and Cost of Additional Capacity

Year	Unit Added	Summer Rating (MW)	Unit Type	Capacity Cost (\$/kW)	Fuel Cost (cent/kWh)
2004	Trimble Co CT 7	155	Combustion Turbine	367	6.02
	Trimble Co CT 8	155	Combustion Turbine	367	6.02
	Trimble Co CT 9	155	Combustion Turbine	367	6.02
	Trimble Co CT 10	155	Combustion Turbine	367	6.02
2005					
2006					
2007					
2008					
2009					
2010	Baseload Unit	549	Baseload	1402	1.16
2011					
2012					
2013	Greenfield CT 1	148	Combustion Turbine	546	7.26

PeriodNarr [v3] SummerPk WinterPk OffPeak

**2004**

Avoided Cost By Period For Total System

Seq	Resource	Period tota	1	2	3
1	VIRTUAL PURCH 1				
	(GWh)	878.4	114.4	97.5	666.5
	(000 \$)	17457.08	3574.03	1874.07	12008.98
	(\$/MWh)	19.87	31.24	19.22	18.02
2	VIRTUAL PURCH 2				
	(GWh)	1756.8	228.8	195	1333
	(000 \$)	33198.39	6785.91	3624.33	22788.16
	(\$/MWh)	18.9	29.66	18.59	17.1
3	VIRTUAL PURCH 3				
	(GWh)	2635.2	343.2	292.5	1999.5
	(000 \$)	44900.66	8772.57	4895.19	31232.89
	(\$/MWh)	17.04	25.56	16.74	15.62

**2005**

Avoided Cost By Period For Total System

Seq	Resource	Period tota	1	2	3
1	VIRTUAL PURCH 1				
	(GWh)	876	114.4	94.5	667.1
	(000 \$)	17852.66	3570.7	1695.89	12586.06
	(\$/MWh)	20.38	31.21	17.95	18.87
2	VIRTUAL PURCH 2				
	(GWh)	1752	228.8	189	1334.2
	(000 \$)	33895.62	6551.42	3742.68	23601.52
	(\$/MWh)	19.35	28.63	19.8	17.69
3	VIRTUAL PURCH 3				
	(GWh)	2628	343.2	283.5	2001.3
	(000 \$)	46146.84	8875.25	4774.42	32497.16
	(\$/MWh)	17.56	25.86	16.84	16.24

**2006**

Avoided Cost By Period For Total System

Seq	Resource	Period tota	1	2	3
-----	----------	-------------	---	---	---



1 VIRTUAL PURCH 1					
(GWh)	876	113.1	94.5	668.4	
(000 \$)	18185.14	3926.56	1804.55	12454.03	
(\$/MWh)	20.76	34.72	19.1	18.63	
2 VIRTUAL PURCH 2					
(GWh)	1752	226.2	189	1336.8	
(000 \$)	34047.05	7370.79	3730.51	22945.74	
(\$/MWh)	19.43	32.59	19.74	17.16	
3 VIRTUAL PURCH 3					
(GWh)	2628	339.3	283.5	2005.2	
(000 \$)	47644.34	9664.83	5141.07	32838.44	
(\$/MWh)	18.13	28.48	18.13	16.38	

**2007**

## Avoided Cost By Period For Total System

Seq	Resource	Period tota	1	2	3
1 VIRTUAL PURCH 1					
(GWh)	876	111.8	96	668.2	
(000 \$)	20110.36	4289.23	2135.9	13685.23	
(\$/MWh)	22.96	38.37	22.25	20.48	
2 VIRTUAL PURCH 2					
(GWh)	1752	223.6	192	1336.4	
(000 \$)	36997.31	7830.12	3717.02	25450.18	
(\$/MWh)	21.12	35.02	19.36	19.04	
3 VIRTUAL PURCH 3					
(GWh)	2628	335.4	288	2004.6	
(000 \$)	50870.07	10403.75	5025.19	35441.13	
(\$/MWh)	19.36	31.02	17.45	17.68	

**2008**

## Avoided Cost By Period For Total System

Seq	Resource	Period tota	1	2	3
1 VIRTUAL PURCH 1					
(GWh)	878.4	113.1	100.5	664.8	
(000 \$)	20948.13	4431.77	2288.52	14227.84	
(\$/MWh)	23.85	39.18	22.77	21.4	
2 VIRTUAL PURCH 2					
(GWh)	1756.8	226.2	201	1329.6	
(000 \$)	39709.71	8508.43	4325.73	26875.54	
(\$/MWh)	22.6	37.61	21.52	20.21	

Conroy

3 VIRTUAL PURCH 3				
(GWh)	2635.2	339.3	301.5	1994.4
(000 \$)	54440.59	11354.81	6000.37	37085.41
(\$/MWh)	20.66	33.47	19.9	18.59

**2009**

## Avoided Cost By Period For Total System

Seq	Resource	Period tota	1	2	3
1 VIRTUAL PURCH 1					
(GWh)	876	114.4	97.5	664.1	
(000 \$)	24439.32	4967.64	2873.05	16598.63	
(\$/MWh)	27.9	43.42	29.47	24.99	
2 VIRTUAL PURCH 2					
(GWh)	1752	228.8	195	1328.2	
(000 \$)	46003.56	9354.79	5362.68	31286.08	
(\$/MWh)	26.26	40.89	27.5	23.56	
3 VIRTUAL PURCH 3					
(GWh)	2628	343.2	292.5	1992.3	
(000 \$)	61384.92	12665.27	6740.46	41979.2	
(\$/MWh)	23.36	36.9	23.04	21.07	



LG&E Energy LLC  
220 West Main Street (40202)  
P.O. Box 32030  
Louisville, Kentucky 40232

July 26, 2004

Elizabeth O'Donnell, Executive Director  
Public Service Commission  
211 Sower Boulevard  
P. O. Box 615  
Frankfort, Kentucky 40601

**RECEIVED**

JUL 26 2004

**PUBLIC SERVICE  
COMMISSION**

***Re: TARIFF FILING OF KENTUCKY UTILITIES COMPANY  
TO REVISE RATES FOR SMALL POWER PRODUCTION  
AND COGENERATION – CASE NO. 2004-00200***

Dear Ms. O'Donnell:

Please find enclosed and accept for filing the original and five (5) copies of the Response of Kentucky Utilities Company to the Information Requested in the Commission's Order dated July 16, 2004, in the above-referenced matter.

Should you have any questions concerning the enclosed, please contact me at your convenience.

Respectfully,

A handwritten signature in black ink, appearing to read "R. M. Conroy".

Robert M. Conroy  
Manager, Rates

Enclosures



COMMONWEALTH OF KENTUCKY  
BEFORE THE PUBLIC SERVICE COMMISSION OF KENTUCKY

**RECEIVED**

JUL 26 2004

PUBLIC SERVICE  
COMMISSION

**In the Matter of:**

TARIFF FILING OF KENTUCKY UTILITIES )  
COMPANY TO REVISE RATES FOR SMALL ) CASE NO. 2004-00200  
POWER PRODUCTION AND COGENERATION )

RESPONSE TO  
AN ORDER OF THE  
PUBLIC SERVICE COMMISSION  
DATED JULY 16, 2004

**FILED: July 26, 2004**

**KENTUCKY UTILITIES COMPANY**

**CASE NO. 2004-00200**

**Response to an Order of the Public Service Commission Dated July 16, 2004**

**Question No. 1**

**Responding Witness: Keith Yocum**

Q-1. Refer to the response to Item 1(b) of the Commission's June 3, 2004 Order. Provide a detailed explanation for why it is appropriate to determine KU's avoided costs in the manner described in the response and why a capacity component should not be included in the derivation of KU's rates for the purchase of power from qualifying cogeneration or small power production facilities.

A-1. Small power production facilities of less than one MW would not delay the installation of future capacity. Therefore, such facilities would not provide any capacity benefit to existing customers. It is also assumed that this power would be non-firm and non-dispatchable in nature and not a reliable resource on which the Utility would be able to call upon in a time of need.

If a small power production facility were to provide the Utility with a firm product (including liquidated damages for failure to deliver) then a capacity component could be considered.

**LOUISVILLE GAS AND ELECTRIC COMPANY**

**Response to Commission Staff's Fifth Request for Information  
Dated March 19, 2021**

**Case No. 2020-00350**

**Question No. 16**

**Responding Witness: William Steven Seelye**

- Q-16. Refer to the Seelye Testimony, page 53, line 53, through page 54, line 2. Mr. Seelye refers to a small sample size and in footnote 19 states that the “data is intended to be illustrative.” Confirm that KU/LG&E are not implying that the sample was sampled using a formal statistical sampling approach, such as those used for load research. If a formal statistical sampling approach was used, provide all analysis used in the development of sampling process, including communications from any consultants that were relied upon.
- A-16. The Companies’ load data for customer-generators was not developed using a formal stratified random sample approach; rather, the load data the Companies have for customer-generators comes from a self-selected sample of such customers who have chosen to participate in the Companies’ Advanced Metering Systems Customer Offering. Having a formal stratified random sample data set was not necessary to support the Companies’ net metering proposals in these proceedings because the Companies did not intend to propose—and are not now proposing—separate rate classes for net metering customers.

But after giving additional consideration to certain data requests and reviewing intervenor testimony, the Companies performed statistical tests (the T Test and Wilcoxon Test) to determine whether the load data the Companies have for customer-generators constitutes a statistically valid sample of the customer-generator population. See the attached results from the LG&E analysis.

The Companies have determined that LG&E’s load data for customer-generators falls slightly short of the standard the Companies target for their class load research data, namely the standard originally established in Section 133 of the Public Utilities Regulatory Policies Act (PURPA) requiring 10% reliability at the 90% confidence level.<sup>11</sup> Nonetheless, LG&E’s data is directionally consistent with KU’s data, which does meet the PURPA standard.

---

<sup>11</sup> See, e.g., Argonne National Laboratory Load Research Manual, Vol. 1: Load Research Procedures at 20 (Nov. 1980) (“Data gathered through customer sample metering must display a 10% reliability level and a 90% confidence level at the hour of the monthly system and group peak demand; if these targets are not met, the utility must explain why.”), available at <https://www.osti.gov/servlets/purl/6705685> (accessed on Mar. 24, 2021).

The attachment is being provided in a separate file in Excel format.

**LOUISVILLE GAS AND ELECTRIC COMPANY**

**Response to Commission Staff's Fifth Request for Information  
Dated March 19, 2021**

**Case No. 2020-00350**

**Question No. 17**

**Responding Witness: John K. Wolfe**

- Q-17. Refer to the Seelye Testimony in general. Provide KU/LG&E's distribution system planning guidelines and manuals used for planning, sizing, and replacing distribution system equipment. Include in this response, but do not limit it to, the KU/LG&E's forecasting methodology and how forecasts are relied upon for upgrading distribution equipment, including substations.
- A-17. See attached distribution system planning manual.



# LG&E and KU Distribution Planning Manual

- 1.1. General Planning Guidelines ..... 7**
- 1.2. Substations ..... 7**
- 1.2.1 Loading Guidelines .....7**
- 1.2.2 Determining Load Problem Areas .....8**

- 1.2.3 Distribution System Capacity Expansion..... 8
  - 1.2.3.1. Alternatives to Capacity Expansion ..... 9
  - 1.2.3.2 Determining a Location for Additional Capacity ..... 10
- 1.2.4 General Substation Circuit Guidelines..... 12
  - 1.2.4.1. Lateral Pole Location ..... 12
  - 1.2.4.2 Underground Exit Cables ..... 13
  - 1.2.4.3 Overhead Wire Near Substations ..... 13
  - 1.2.4.4 Number of Circuits Per Transformer..... 13
- 1.3 Distribution Circuit Guidelines ..... 14**
  - 1.3.1 Circuit Capacity Ratings ..... 14
  - 1.3.2 Distribution Circuit Overload Relief..... 15
    - 1.3.2.1 Transfer Load to Surrounding Circuits..... 15
    - 1.3.2.2 Load Transfers with Circuit Modifications..... 15
    - 1.3.2.3 Additional Circuit from Substation..... 15
    - 1.3.2.4 Capacitor Installation ..... 15
  - 1.3.3. Multiple Distribution Circuit..... 16
    - 1.3.3.1 Multiple Circuit Construction ..... 16
    - 1.3.3.2 Multiple Circuit Reliability ..... 16
- 1.4. Voltage Regulators..... 16**
  - 1.4.1 Location/Placement ..... 17
  - 1.4.2 Alternatives to Regulators ..... 17
- 1.5 Reclosers..... 17**
  - 1.5.1 Locations of Reclosers ..... 18

1.5.2	Recloser Application Guidelines .....	18
<b>1.6</b>	<b>Wire and Cable Loading and Upgrade Guidelines.....</b>	<b>19</b>
<b>1.7</b>	<b>Upgrading Conductor Sizes .....</b>	<b>19</b>
1.7.1	Overload Capabilities .....	20
<b>1.8</b>	<b>Circuit Phase Balancing .....</b>	<b>20</b>
<b>1.9</b>	<b>Distribution Circuit Protective Coordination .....</b>	<b>21</b>
1.9.1	Fuse Link Application .....	22
1.9.2	Fuse-to-Fuse Coordination.....	23
1.9.3	Fuse-to-Load Coordination.....	23
1.9.4	Primary Transformer Fusing .....	23
1.9.5	Capacitor Fusing.....	24
1.9.6	Recloser Coordination Principles.....	25
1.9.7	Substation Relay Settings .....	27
1.9.7.1	Feeder Time-Over-Current Relay - Minimum Pickup .....	27
1.9.7.2	Time Dial Setting .....	28
1.9.7.3	Feeder Low Set Instantaneous Relay .....	28
1.9.7.4	Transformer High-Set Instantaneous .....	29
<b>1.10</b>	<b>Shunt Capacitor Application Guidelines .....</b>	<b>30</b>
1.10.1	Capacitor Information Sources and Data Collection.....	31
1.10.2	Control Types and Combinations .....	31
1.10.3	General Location and Sizing Guidelines .....	32
1.10.4	Multiple Switched Banks .....	34
1.10.5	Banks Installed at Other-Than-Rated Voltage .....	34

- 1.10.6 Calculation of Flicker and Net Voltage Rise ..... 35
- 1.10.7 Pitfalls to Avoid ..... 35
- 1.11 Distribution Automation ..... 36**
  - 1.11.1 Introduction to Distribution Automation ..... 36
  - 1.11.2 Definition of Distribution Automation ..... 36
  - 1.11.3 Benefits of Distribution Automation..... 37
  - 1.11.4 A Modular Approach..... 38
    - 1.11.4.1 Substation Automation ..... 38
    - 1.11.4.2 Feeder Automation..... 39
    - 1.11.4.3 Customer Automation ..... 40
  - 1.11.5 Distribution System Representation ..... 40
    - 1.11.5.1 Radial System ..... 40
    - 1.11.5.2 Primary Network System ..... 41
    - 1.11.5.3 System Operations..... 41
  - 1.11.6 Future Implications ..... 42
    - 1.11.6.1 Equipment to be Controlled and/or Monitored..... 42
- 2.1 Load Growth Forecasting ..... 44**
  - 2.1.1 Regression Analysis ..... 44
  - 2.1.2 Procedure ..... 44
  - 2.1.3 Grouping of Substations ..... 44
  - 2.1.4 Equating Growth Rates to the Corporate Forecast..... 44
  - 2.1.5 Non-Coincidental Substation Growth Projections ..... 45
- 2.2 Distribution Analysis ..... 45**

- 2.2.1 Circuit Phase Balancing ..... 45
- 2.2.2 Downtown Network Analysis ..... 46
  - 2.2.2.1 Networks Systems ..... 46
  - 2.2.2.2 Vaults ..... 47
- 2.3 Data Maintenance and Storage ..... 48**
- 2.4 General Project/Task Information ..... 48**
  - 2.4.1 Sources ..... 48
    - 2.4.1.1 Responsibilities ..... 49
- 3.1 General Design Standards ..... 50**
- 3.2 Distribution Transformers ..... 50**
  - 3.2.1 Overhead ..... 50
  - 3.2.2 Underground ..... 51
  - 3.2.3 Network ..... 51
- 3.3 Secondary Circuits and Service Agreements ..... 51**
- 3.4 Underground Cable Ampacity Ratings ..... 52**
- 3.5 Overhead Wire Ampacity Ratings ..... 59**
- 3.6 Voltage Regulations ..... 60**
  - 3.6.1 Rule V ..... 60
  - 3.6.2 Nominal Voltage ..... 61
  - 3.6.3 Voltage Flicker ..... 62
- 3.7 Capacitors ..... 62**
  - 3.7.1 Power Factor ..... 62
  - 3.7.2 Capacitor Bank Types ..... 63

3.7.3 Standard Capacitor Bank Sizes .....63

## 1.1. General Planning Guidelines

The function of the Electric Distribution System Planning Department is to plan for future distribution facilities that will maintain an efficient, cost-effective, self-supporting, reliable power source for its customers under normal and single contingency operating conditions at all times of the year. The distribution system will be designed to operate within all established guidelines during normal and emergency operating conditions.

Planning the electric distribution system involves many variables that can affect the system's operation. One variable that has the most impact is future load growth. The magnitude of growth is secondary to the location of the growth for distribution planning. Forecasting growth in the wrong area could lead to the purchase of property not needed or adding capacity at the wrong location. On the other hand, if the magnitude of growth is forecast incorrectly, but at a suitable location, construction in the area can be delayed until the capacity is needed. This process is based on the premise that equipment lead-time is short compared to the time required to purchase property.

## 1.2. Substations

### 1.2.1. Loading Guidelines

System Planning uses the following criteria for recommending equipment replacement or capacity increases:

- Transformer replacement/increase at 100% of nameplate rating in Summer or 120% of nameplate rating in Winter base on forecasted loading
- Conductor replacement at 100% of thermal rated capacity for season

For new capacity additions, the distribution system is designed to be self-supporting during single contingency conditions for system peak load, where feasible. During the single contingency condition of losing a substation transformer, ideally, the transformers' load can be transferred to surrounding substations if system capacity is available.

The contingency capability of a particular distribution substation transformer depends on several factors. These factors include circuit interconnections to surrounding substations, circuit capacity limitations, the number of circuits, and voltage levels.



The loading on substation transformers shall never exceed 120% during the summer months under any operating condition, normal or emergency, without approval from Distribution Planning. Transformer loading shall not exceed 136% during the winter months without approval. Some substation capacity must be reserved for future load growth. The amount of capacity reserved for future load growth varies and depends on the load growth rate of the area. Contingency studies aid in determining the maximum load level allowable on a substation. Contingency studies are an iterative process. These studies consider distribution circuit limitations, switching, and voltage drop levels. A contingency study on substation "A" may indicate the substation can be loaded to 90 percent of capacity. A contingency study on a neighboring substation "B" may indicate that all of the load cannot be transferred to surrounding substations if substation "A" is loaded to 90 percent. At this point, it becomes an iterative process between one substation and surrounding substations to determine the optimum load level for each substation.

Analyses indicate some periods of transformer overload are allowable and result in little or no loss of transformer life. For more information on transformer ratings and permissible overload levels, refer to the section titled "Power Transformer Loading and Loss of Life" in the Appendix.

### **1.2.2 Determining Load Problem Areas**

All substation and circuit loads, if available, are to be reviewed annually. Substation summer and winter peak loads are used to forecast load growth. Load growths are forecasted for all distribution substations.

Using forecasted and current loads, substations with loads of 90 to 100 percent of transformer capacity within the next five years are analyzed to determine the need for load relief. Substations in the 90- to 100-percent range beyond five years are reviewed to determine the possible need for capacity additions. Detailed analysis is not performed beyond five years due to the uncertainty of available information.

Distribution circuits represent areas of the system too small to forecast load growth. Circuits are analyzed for load relief when it is determined they will exceed their normal rated capacity.

### **1.2.3 Distribution System Capacity Expansion**

After locating problem areas, contingency studies are made to determine if additional transformer capacity is needed. Before capacity expansion is considered in an area, alternatives are explored.

### 1.2.3.1. Alternatives to Capacity Expansion

#### 1) Capacitor additions to the system

If surrounding substations are unable to carry all unserved load during single contingency conditions, adding capacitors to the system may reduce substation loading enough to delay capacity expansion. Adding capacitors to the distribution system reduces kVAR flow on the lines. A reduction in kVAR flow reduces the total MVA load on substation transformers. Care must be taken not to add too much capacitive kVAR, which would be detrimental to the system.

#### 2) Reconductoring

When surrounding substation transformers are not loaded above the planning guidelines during single contingency conditions, and the contingency studies indicate unserved load, then distribution circuits are limiting load transfers. Load transfer limitations are caused by overloaded wires, low voltage levels, or both. Distribution voltage levels must be maintained within the design limit standards. Reconductoring to larger wire may solve the problem by reducing voltage drop along the circuit and increasing circuit capacity.

#### 3) Addition of Distribution Circuits

Adding a distribution circuit(s) may also remedy the problem of load transfer capabilities between substations. Adding a circuit can be a cheaper alternative than reconductoring several circuits. There are some drawbacks to adding circuits. Drawbacks and limitations to multiple circuits from a substation are covered in Section 1.3.

#### 4) Automated Distribution

Distribution automation can assist in automatically transferring load between circuits and substations. Use of this technology to avert capacity expansion is most advantageous when substations or circuits have different peaking periods. The diversity in peaking periods allows portions of load to be transferred between circuits or substations. By transferring load between a peaking and non-peaking substation or circuit, capacity expansion or reconductoring may be avoided. For more information and other benefits of distribution automation, see Section 1.11.

If surrounding substations are still unable to carry all the load in an area during a single contingency after exploring the alternatives, additional transformer capacity is required. The capacity addition can be installed at an existing substation or require the construction of a new substation.

### **1.2.3.2 Determining a Location for Additional Capacity**

A feasible location for additional transformer capacity must be determined. The location must resolve present loading problems and provide capacity for future load growth. Future substation sites and transformer capacity expansion to existing substations are analyzed using the Distribution System planning tools.

The following paragraphs provide guidelines for selecting future substation sites or substations needing additional transformer capacity.

#### **1.2.3.2.1 Substation Transformer Capacity Addition**

Load growth in established distribution service areas often dictates transformer capacity expansion at an existing substation. The location of the projected load growth is important in deciding where to add capacity. Large residential, commercial, and industrial developments submit proposals to the local planning board. This information can be used to track new area developments that can affect substation loadings over the next five years. This information is obtained from the Real Estate and Right-of-Way Department, Business First articles, and newspapers.

Substation load forecasts are also used to determine expansion needed at existing substations. Knowing the location of proposed developments and using substation load forecasts, the most advantageous location of capacity expansion can be determined. Contingency studies are made on the area selected for capacity expansion using projected load growth. Contingency studies help to verify the feasibility of the capacity expansion location for future and present load levels.

#### **1.2.3.2.2 New Substation Site Selection Factors**

There are several factors to be considered for selecting a distribution substation site.

##### **1) Location of Existing and Future Load**

Using forecasted substation load data, present substation load data, and maps indicating present and proposed developments, a substation site

can be approximated on a map. Once a site is approximated, studies are made to determine how much existing load can be transferred to the new substation.

## 2) Location of Existing Distribution Lines

When possible, distribution substation sites should be located close to the main routes of existing distribution circuits. This helps to lower the distribution costs for new circuits out of the substation. A substation site isolated from main distribution lines would require completely new pole routes and the acquisition of new right-of-way to tie circuits to the existing distribution system.

The substation should be located close to a road intersection, if possible. Locating near an intersection will enable distribution circuits to go in multiple directions from the substation. This helps eliminate multiple circuits along the same route. This also provides for easier circuit additions in the future.

## 3) Load Transfer Capabilities

Consideration is given to the ability to transfer loads from substation to substation under single contingency conditions. A substation site located too far from existing substations may not provide or receive adequate backup support to the distribution system due to low voltage conditions. Sometimes, there may be no choice in the matter due to the location of projected future loads.

## 4) Location of Existing Transmission Lines

Future substation sites should be located as close as possible to existing transmission lines. This is based on the same logic as for distribution circuits. Transmission lines are more costly to construct than distribution lines. Transmission line location should weigh heavily in substation site location because of construction costs.

## 5) Location of Existing Distribution Substations

When a substation site is considered, a map of the area is used to determine the distances between the proposed site and existing substation locations. It is preferred to have substations equidistant from each other. Substations equidistant from each other normally provide good load transfer capabilities under single contingency conditions.

## 6) Availability of Land

The preceding factors are based upon engineering design and system economics in determining a feasible location for new substation sites. The area chosen for a new substation may not have land available for the substation. Areas near the desired location are considered if the desired location is unavailable. Once property is found that can be purchased, each of the previous factors are re-evaluated to determine if the property is satisfactory from an engineering and economic standpoint.

In addition to the above-mentioned factors, a check should be made with Transmission Planning to determine if any problems might occur with a new substation concerning transmission system stability or line loading. When all factors have been addressed, a check is made by Engineering personnel to determine if it is possible to construct a substation on the proposed site. If the site is suitable for construction, the Real Estate and Right-of-Way Department attempts to purchase the property, after management approval.

It is best to determine future substation sites a few years in advance. Early location of possible sites improves the chances of purchasing property where needed. Waiting too long to purchase a substation site can cause problems. It is more difficult to purchase property in areas being developed. Generally, there is greater public opposition to new substation sites in developed areas. Aesthetic consideration must be given in the development of the substation site.

#### **1.2.4 General Substation Circuit Guidelines**

This section contains guidelines to consider when designing a new distribution substation and associated distribution circuits.

##### **1.2.4.1. Lateral Pole Location**

Lateral poles should be placed as far away from the substation and from each other as practical. The exact location should be based on economics, design practicality, and aesthetics. Lateral poles placed immediately outside the substation give a cluttered and unattractive appearance to the distribution system and substation. If the lateral poles are placed close together, there can be multiple circuits on the same pole route. Multiple circuits on the same pole route should be avoided for reliability reasons. Refer to the "Distribution Circuit Guidelines," Section 1.3, for more information on multiple circuits.

#### 1.2.4.2 Underground Exit Cables

Underground cables leaving the transformer switchgear to the lateral pole should have a minimum ampacity rating of 600 amps and a minimum insulation class of 15 kV.

#### 1.2.4.3 Overhead Wire Near Substations

Spacer cable allows several distribution circuits to be placed on a single pole route. Multiple circuits from a single substation should always be considered a possibility for future capacity expansion. While multiple circuits on a single route are not desirable, sometimes it is unavoidable due to growth in an area and number of limited distribution routes. Farther away from the substation, open wire may be used.

#### 1.2.4.4 Number of Circuits Per Transformer

Typically, the number of circuits from a given transformer is limited due to the MVA rating of the transformer and the capacity rating of each circuit.

Guidelines for the number of circuits from a transformer are:

<u>Transformer MVA</u>	<u>Typical Max. Number of Circuits</u>
10.0	2
28.0	4
44.8	5

The normal capacity rating for a 12.47 kV or 13.8 kV circuit is 10 MVA. One circuit is generally reserved for backup support to the other circuits for various operating situations. This circuit has no load or is lightly loaded. If all circuits on a transformer are utilized, the maximum load each circuit can carry may be limited by the transformer capacity rating. For example, five circuits on a 44.8 MVA transformer can carry approximately 9 MVA each. However, all circuits cannot carry 10 MVA without overloading the transformer. Therefore, the maximum circuit MVA for all circuits, if loaded equally, is 9 MVA instead of 10 MVA.

## 1.3 Distribution Circuit Guidelines

### 1.3.1 Circuit Loading Guidelines

#### 12.47 kV and 13.8 kV Circuits

In general, 12.47 kV and 13.8 kV circuits are designed to have normal and contingency condition loading guidelines as given below.

#### Circuit Ratings

Normal	440 amps
Contingency	600 amps

The circuit capacity-limiting factor, in most instances, is the size of the underground exit cable from the substation. The overhead conductor size at the lateral pole can also limit a circuit's normal and contingency operating capacity.

Typically, new distribution circuits use 1000 kcmil, aluminum, single conductor, or 750 kcmil, copper, single conductor, underground exit cables. Either 795 AA open wire or 795 AA spacer cable is used for the overhead distribution leaving the lateral pole. Occasionally, 336 AA open wire or 336 AA spacer cable may be used. The wire size used is dependent on load and voltage drop conditions. Underground exit cable sizes and overhead wire sizes leaving the substation should be checked to determine the normal operating and contingency capacity rating of a circuit.

The normal circuit capacity ratings give operating personnel the ability to transfer loads under contingency conditions without creating low voltage problems and circuit overloads. A contingency condition is defined as the loss of a distribution circuit or a substation transformer. If circuits are loaded to their maximum capacity (i.e. 600 amps), inability to switch loads under contingency conditions can cause customers to be without power for long periods.

#### 4.16 kV Circuits

The 4.16 kV distribution circuits are some of the oldest on the system. There is no set capacity rating for these circuits. Each circuit's capacity rating will vary according to the size of the underground exit cable or overhead wire leaving the substation lateral pole. The most common underground exit cable used on 4.16 kV circuits is 350 kcmil, three conductor, paper-lead-rubber (PLR). Over the years, many of these cables have been replaced with 500 kcmil, single conductor, cross-link polyethylene (XLP) insulation. Substation cut-sheets are

used to determine the exact type of underground exit cable. The overhead wire size leaving the substation lateral pole must be checked to ensure it is not limiting the circuit's capacity.

### **1.3.2 Distribution Circuit Overload Relief**

All distribution circuits are reviewed yearly to check for overloaded conditions, where data is available. An overloaded condition is when a circuit exceeds its normal operating capacity. Circuits exceeding their normal operating capacity are targeted for relief.

Alternatives to relieve overloaded circuits:

#### **1.3.2.1 Transfer Load to Surrounding Circuits**

This alternative is the most used and usually the most economical to accomplish overload relief. Load is transferred to surrounding circuits using the existing lines by opening and closing switches. In some instances, it is necessary to install switches to avoid transferring too much load. Switches are not installed on single or two-phase sections of a circuit. Transfers are predominately made on three-phase sections of a circuit. Reconductoring may be required for capacity purposes.

#### **1.3.2.2 Load Transfers with Circuit Modifications**

It may be necessary to establish new tie points with surrounding circuits to transfer loads. New tie points are only made with three-phase portions of a circuit. Reconductoring single-phase or two-phase sections of a circuit to three-phase may be required to establish new tie points. A new pole route may be necessary to transfer loads, but is a last resort due to expense and the need for right-of-way acquisition.

#### **1.3.2.3 Additional Circuit from Substation**

A new circuit can be added to relieve loading on an existing circuit. This is done as a last resort and must consider load growth in the area to determine the best route for the new circuit. Refer to the "Addition of Distribution Circuits" in Section 1.2.3 for more information and guidelines.

#### **1.3.2.4 Capacitor Installation**



Addition of capacitors can reduce the magnitude of power flow on a circuit. Generally, capacitor installation is not a feasible alternative. Usually the circuit power factor will be at a level where the amount of capacitors that can be added will not reduce circuit loading by any significant amount. Refer to the "Capacitor Additions to the System," Section 1.2.3, for more information and guidelines.

### **1.3.3. Multiple Distribution Circuit**

When additional transformers are installed at an existing substation, it may be necessary to construct multiple circuits on the same pole route.

#### **1.3.3.1 Multiple Circuit Construction**

Spacer cable is used for circuit construction near substations. Spacer cable allows more circuits to be placed on the same pole route while limiting the pole height needed. Multiple open wire circuits can be placed on the same pole route, but require greater pole height. Open wire and spacer cable circuit construction can be used together when necessary. When multiple circuit routes reach a point on the distribution system where they split into separate directions, open wire can be used.

#### **1.3.3.2 Multiple Circuit Reliability**

Multiple circuit construction should be avoided when possible. This type of construction decreases the reliability of the distribution system. When pole routes with multiple circuits are lost due to storms, car hitting a pole, etc., more customers are affected. Load transfer capabilities to restore power to customers are limited because two or three circuits are lost at one time.

## **1.4. Voltage Regulators**

Voltage regulators automatically adjust the line voltage up or down as required by changing voltage levels. Regulators can provide up to  $\pm 10$  percent voltage regulation. Regulators are not normally bi-directional.

Since the regulators are not normally bi-directional, their use should be minimized in areas where load transfers between circuits can occur. Regulators must be taken off-line if fed from an opposite direction or they will be in a buck position, which lowers the voltage level instead of increasing it.

### 1.4.1 Location/Placement

Voltage regulators are placed on distribution lines where the primary voltage drop level is in the range of six to seven percent during circuit peak load conditions. The six to seven percent range is based upon maintaining the minimum secondary voltage level of 114 volts at the customers' entrance.

Generally, regulators are placed on long circuits serving fringe areas of the service territory. Regulators can be used to delay expensive line reconductoring to outlying areas with slow load growth, but that have voltage drops exceeding acceptable levels.

### 1.4.2 Alternatives to Regulators

Use of voltage regulators should be minimized if alternatives are more economical or provide a more stable and reliable system. Future load growth is considered in the assessment of alternatives for voltage regulators.

Capacitors - Capacitors provide some voltage regulation on distribution circuits. The amount of voltage support offered by capacitors is dependent upon kVAR size and distance from the substation. Refer to the section on Capacitors for more information.

Reconductoring - Reconductoring to larger wire sizes improves voltage levels along the circuit. Reconductoring should be considered in densely loaded areas or where heavy load growth is expected in the near future.

## 1.5 Reclosers

An automatic circuit recloser is a self-contained device with the necessary intelligence to sense an overcurrent, wait a set time, interrupt the overcurrent, and reclose automatically to re-energize the line. If the fault should be permanent, the recloser will lock open after a preset number of operations and isolate the faulted section from the main part of the system. Automatic circuit reclosers are classified as single or three-phase, hydraulically or electronically controlled, with oil or vacuum interrupters.

Studies of overhead distribution systems have established that approximately 80 to 95 percent of all system faults are temporary in nature and last only a few cycles to a few seconds. The automatic circuit recloser, in providing a "trip and reclose" function, eliminates prolonged outages on distribution systems due to temporary faults or transient overcurrent conditions.

### **1.5.1 Locations of Reclosers**

Reclosers can be used anywhere on a system where the recloser ratings are adequate for the system requirements. Reclosers are usually installed as a response to frequent outages in heavily-treed areas.

Logical locations are:

- 1) In substations as the primary feeder protective device.
- 2) On the lines at a distance from a substation, to sectionalize long feeders and thus prevent outages of the entire feeder for a permanent fault occurring near the end of the feeder.
- 3) On taps off main feeders to protect the main feeder from interruptions and outages due to faults on the taps.

### **1.5.2 Recloser Application Guidelines**

For proper application of automatic circuit reclosers, five major factors must be considered:

- 1) System voltage

The recloser must have a voltage rating equal to or greater than the system voltage.

- 2) Maximum fault current available at the point of recloser location

The recloser interrupting ratings must be equal to or greater than the maximum available fault current at the location selected for replacement.

- 3) Maximum load current

The maximum continuous current rating of the recloser is selected to be equal to or greater than the anticipated circuit load. In hydraulically controlled reclosers, the continuous current rating of the series coil selected may be equal to or less than the maximum continuous current rating of the recloser. The minimum trip rating, also a property of the series coil, normally is twice the coil continuous rating and should be at least twice the expected peak load current. A trip current value at least twice the expected peak load current is used.

- 4) Minimum fault current within the zone to be protected by the recloser.

The minimum fault current that might occur at the end of the line section must be checked to determine if the recloser will sense and interrupt this current.

- 5) Coordination with other protective devices on both source and load sides of the recloser.

Coordination with other protective devices (both source side and load side) becomes important after all other application factors are satisfied. Proper selection of time delays and sequences is vital to ensure that any momentary interruption or long-term outage due to a fault is restricted to the smallest portion of the circuit.

## **1.6 Wire and Cable Loading and Upgrade Guidelines**

For ampacity ratings of underground cables and overhead wires used on the distribution system, refer to the "Overhead Wire & Underground Cable Ampacity Ratings" in Section III titled Distribution Planning Standards.

## **1.7 Upgrading Conductor Sizes**

A loadflow analysis is performed on each circuit of the distribution system to calculate the approximate loading on overhead wires or underground cables. The analysis is performed for peak load levels on the circuit.

Underground cables and overhead wires above 90 percent of capacity are noted. Wire and cables are upgraded to larger sizes when they reach 100 percent of their capacity rating. Since the analysis is based upon peak load conditions, the conductors will only see these load levels a few hours a day and for only a few days per year. Upgrades are not made before the loading on the cable reaches this point unless there are other mitigating circumstances.

Mitigating circumstances that will force early conductor upgrades are:

- 1) New load growth in the area
- 2) Excessive voltage drop levels
- 3) Wire annealing
- 4) Load transfer limitations

### 1.7.1 Overload Capabilities

At present, there are no established overload criteria levels used for underground cable or overhead wire for emergency situations. Overhead wire emergency ratings will vary throughout the distribution system depending upon the type of circuit construction used and wire sags. Underground construction standards are fairly constant. However, underground cable emergency ratings can vary due to the cables' proximity to other underground circuits. This is especially true at substations where multiple circuits are in the same duct bank. The mutual heating effect of other circuits will derate the load-carrying capabilities of the conductors. The loading of the other circuits must be considered in determining the emergency rating of a cable. In any case, both overhead wire and underground cable emergency overload ratings need to be determined on a case-by-case basis.

## 1.8 Circuit Phase Balancing

On each distribution circuit, it is desired to maintain a proper balance of current between phases along the line. The three principle reasons for phase balancing are:

- 1) To keep the wire from heating excessively.
- 2) To maintain the lowest possible heat losses in the wire.
- 3) To minimize the voltage drop at the customer's entrance.

The first two objectives are realized by having equal currents in each phase. Minimizing voltage drop is more complicated; the line configuration must be taken into consideration. If the phases are equally spaced, such as spacer cable and some forms of armless construction, then equal currents will cause equal voltage drops. However, if the circuit is built on normal cross arm construction, then the reactances are not equal in each phase, thus the drops are not equal. To maintain equal voltage drops for cross-arm construction, the currents should be divided as follows:

A ( - 33 %

B ( - 35 %

C ( - 32 %

Total - 100 %

Some circuits will require balancing to minimize voltage drops, but many of these circuits will be unique and require a special study. If one phase must be high, make it B $\phi$ , and if one phase must be low, make it C $\phi$ .

### Circuit Balancing Guidelines

#### Current Balancing

A balance is considered good when all phase currents are within  $\pm 10$  percent of the average current ( $\pm 5$  percent for average currents more than 300 amps).

When one phase current is 20 percent (10 percent for currents above 300 amps) above or below the average, remedial measures are in order.

If the average current is under 50 amps per phase and no phase current is above 80 amps, neglect the balance because currents of these magnitudes should seldom cause problems. These circuits can be used to maintain a phase balance on the substation if needed.

#### Voltage Balancing

A balance is considered to be good when all phase voltages are within 3 percent of the average voltage. This is sometimes hard to achieve when a 3 $\phi$  customer is near the end of a circuit. However, due to the problems this could cause customers, attempts should be made to balance the voltage.

Per NEMA derating curves, at 3 percent voltage imbalance, motors should be derated to 90 percent, at 5 percent voltage imbalance motors should be derated to 74 percent, and motors should not be operated at greater than 5 percent voltage imbalance.

## **1.9 Distribution Circuit Protective Coordination**

When new distribution circuits are created, protective coordination is needed. Protective device coordination ensures that the least amount of customers are affected when fault conditions occur. The following sections provide guidelines to consider, and a brief explanation of devices used for protection.

### 1.9.1 Fuse Link Application

Correct fuse link application requires knowledge of the system characteristics and equipment to be protected. For fuses located in the line for sectionalizing purposes, the following factors should be considered:

- 1) Normal and overload currents of the circuit including sustained harmonics.
- 2) Transient current of the circuit such as transformer magnetizing currents, motor starting currents, capacitor inrush current, and cold-load pick-up current.
- 3) Burn-down and annealing characteristics of the conductors.
- 4) Coordination with other protective devices for equipment protection. Factors that should be considered are:
  - a) Overload and short-time capabilities of the equipment.
  - b) Transient currents such as magnetizing inrush current, lighting surges, and capacitor inrush current.
  - c) Relative importance of protecting the equipment versus providing service continuity.
  - d) Coordination with other protective devices.

#### Application Rules

By conventional definition, when two or more fuse links or other protective devices are applied on a circuit, the device nearest to the fault on the supply side is the protecting device, and the next device, nearest the supply, is the backup or protected device.

One essential rule for application of fuse links states that the maximum clearing time for the protecting link shall not exceed 75 percent of the minimum melting time of the protected link. This principle assures that the protecting link will interrupt and clear the fault before the protected link is damaged. The 75 percent factor compensates for operating variables such as preloading, ambient temperatures, and heat of fusion.

#### Coordination Principles

The load side device must clear a permanent or temporary fault before the source side interrupts the circuit (fuse link) or operates to lockout (recloser).

Outages caused by permanent faults must be restricted to the smallest protected section of the circuit.

### **1.9.2 Fuse-to-Fuse Coordination**

Fuse link coordination can be achieved by the use of time-current curves and coordination tables. Coordination tables are based on data derived from the time-current curves and are located in the appendix.

For fuse-to-fuse coordination, the calculated available fault current should be used with Table 2 in the Appendix. This table is based on maximum clearing-time curves for protecting links and 75 percent of minimum-melting time curves for protected links.

#### **Branch Line Fused Cutouts**

For sectionalizing purposes, cutouts should be installed on some three-phase taps (depending on the load and tree conditions) and on all single-phase taps feeding from the main circuit more than one span.

### **1.9.3 Fuse-to-Load Coordination**

The minimum size fuse to be used for overhead installations and underground laterals shall be determined by the fusing charts in the Appendix. This is the minimum size necessary to carry cold-load pick-up current, overload current, and transient current.

### **1.9.4 Primary Transformer Fusing**

Two distinctly different types of protection are obtained with primary transformer fusing.

- 1) The system is protected by removal of those transformers that fail or have low impedance short circuits on the secondary side. A minimum number of customers are affected because the balance of the system continues to operate normally.



- 2) The transformer is protected against overload and secondary high-impedance faults and internal faults. Fuse link selection depends on the degree of overload protection desired and practices vary widely among utilities.

Self-protected transformers provide protection by using a secondary breaker to provide overload and secondary fault protection, while an internal fuse link in the primary removes the transformer from the line in case of failure. The internal fuse is purposely sized to blow only when the transformer is damaged.

See the Appendix for transformer protective fuse sizes.

### **1.9.5 Capacitor Fusing**

Capacitor banks on distribution systems usually include several single-phase units mounted in one rack and connected as a three-phase installation. Group-fusing methods are economical for most installations. Properly selected fuse links protect the distribution system by rapidly removing a faulted capacitor from the line and preventing damage to adjacent capacitors. Because a capacitor unit is a static device and represents a constant load when operated at rated voltage, coordination of capacitor fuse links with other fuse links presents no problem in most cases.

Tank rupture curves are essential to the correct selection of capacitor fuses. Standard NEMA tank rupture curves for capacitor units afford the advantage of adopting uniform fusing practices for capacitors from all manufacturers. Fuse selection is based upon the probability of tank rupture indicated by the curves and the maximum clearing time characteristic of the fuse link.

#### Capacitor Bank Protection and Fusing

- 1) On a delta configured system, ungrounded wye banks are used. This is done to avoid interference with the ground relaying devices because of the low impedance ground path produced with grounded banks. An added benefit is reduced odd harmonics on the system. Since, in an ungrounded wye bank, the fault current is limited to three times the normal current, problems associated with operating in the wrong portion of the case-rupture probability diagram are reduced. In other words, the limited fault current reduces the likelihood of capacitor bank failures under fault conditions. Another advantage is that only two oil switches are needed to electrically remove the bank from the line. Problems may arise from neutral inversion or resonant

conditions due to single-phase switching, although this has not been a problem in the past.

- 2) On grounded-wye systems, grounded wye banks are normally used. However, it is necessary at certain locations to install ungrounded wye banks to hold fault current to acceptable limits. When fault currents are above 5000 amps phase-to-ground, an ungrounded wye bank needs to be used. This is necessary to hold the case-rupture probability to acceptable values. In practice, no capacitor bank on the wye connected systems should be placed where the available fault current exceeds the fault rating of the capacitors, if possible.

For any bank configuration, some basic rules for fusing exist.

Basic Fusing Rules

- 1) It must have sufficient interrupting capacity.
- 2) It must be capable of carrying continuously 165 percent of the rated capacitor current. This is required because of the current increase caused by harmonics.
- 3) It must withstand a switching surge and discharge current.
- 4) For an ungrounded wye bank, the fuse should clear within five minutes.
- 5) Fault current levels should not exceed the tank rupture rating of the capacitors.

These requirements may, at times, necessitate group fusing of capacitor banks or an ungrounded wye configuration.

### **1.9.6 Recloser Coordination Principles**

Proper application of automatic circuit reclosers on a distribution system is assured if the following basic coordination principles are observed:

- 1) The load-side device must clear a permanent or temporary fault before the source-side device interrupts the circuit (fuse link) or operates to lockout (recloser).
- 2) Outages caused by permanent faults must be restricted to the smallest protected section of the circuit.

These principles primarily influence the selection of operating curves and sequences of the source-side and load-side devices, and location of these devices on the distribution system.

#### Recloser-Fuse Link Coordination

Coordination between a recloser and a fuse link can be obtained by using methods based upon time-current curves adjusted by a multiplying factor of 2. Tables in the Appendix can be used to coordinate circuit protection equipment.

Optimum coordination between reclosers and fuse links is obtained by setting the recloser for two fast (A) operations followed by two delayed (B or C) operations. The first recloser opening allows about 80 percent of the temporary faults to clear. The second opening permits approximately another 10 percent to clear. Before the third opening, the fuse link melts, interrupting persistent or permanent faults. For all values of fault current possible on the section protected by the fuse link, the maximum clearing time of the fuse should be no greater than the delayed clearing time (B or C curve) of the recloser.

The optimum size of the recloser should be chosen to give the maximum range of coordination between the recloser and the fuses in series behind it. When coordinating large fuses with small reclosers, if a high-impedance fault will lock out the recloser, judgement should be used in selecting a smaller fuse to protect the recloser. Underground lateral fuses need not be coordinated with reclosers since most faults will be low in impedance and permanent in nature. All overhead fuses should be coordinated between the '2A' and the 'B' or 'C' curves.

#### Recloser Operating Sequence

Louisville Gas and Electric Company uses reclosers with two fast and two delayed operating sequences (2A2C or 2A2B curves).

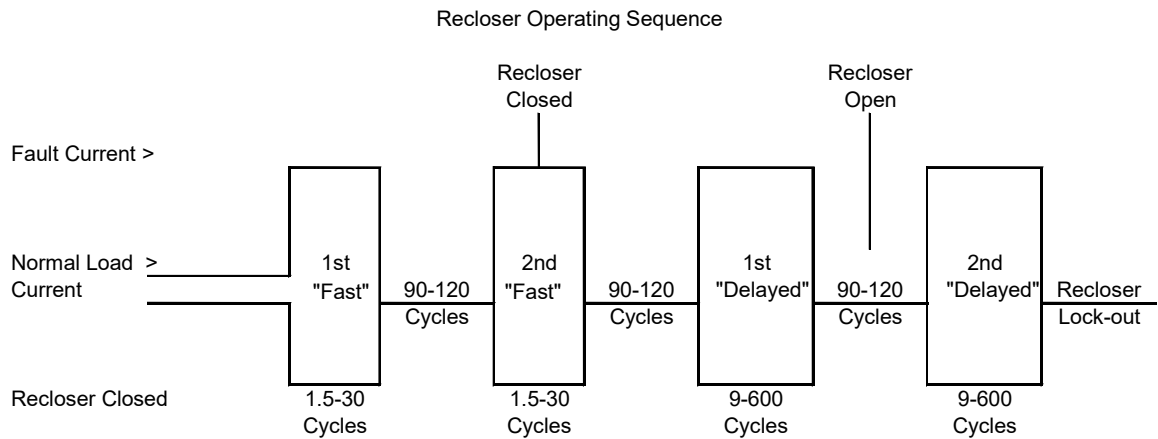

Clearing time on each of the "A" curve operations is approximately 1 and 1/2 to 30 cycles and 9 to 600 cycles on the "B" or "C" curve operations, depending on the magnitude of fault current (time/current curves). Reclosing time between each operation is 90 to 120 cycles.

Reclosers may be used anywhere it is deemed necessary to eliminate prolonged outages on the circuit due to temporary faults.

### Recloser Selection

A recloser must be able to withstand and interrupt 100 percent of the available fault current at the recloser.

The minimum size of the recloser is determined by the load behind the recloser.

NOTE: The optimum size of the recloser is determined by the protective equipment with which it must coordinate.

## **1.9.7 Substation Relay Settings**

### **1.9.7.1 Feeder Time-Over-Current Relay - Minimum Pickup**

The minimum pickup point for the T.O.C. (time over current) relay determines that point at which the circuit will eventually time out, open the breaker, and drop load. The relay can be used as a protective device for thermal overload on either the underground lateral feeder or the first section of overhead conductor. The minimum pickup should be set as close as practical to the emergency thermal limit of the lateral or the feeder, whichever is limiting. At

times, it is necessary to adjust this guideline to coordinate with reclosers and fuses.

Note: The minimum pickup value of a relay should be set using one of the discrete steps provided by the manufacturer. There are provisions to continuously adjust the pickup values between these discrete steps, but on electromechanical relays, this is accomplished by changing the tension of a coil spring. Making this tension adjustment may cause the characteristic curve to change somewhat, especially in the knee of the curve.

Example: With a circuit C.T. ratio of 600/5 and the T.O.C. relay tap set at 6 amps, the minimum pickup value would be 720 amps (600/5 x 6).

### 1.9.7.2 Time Dial Setting

The time dial setting of the relay should be a minimum of 0.25 seconds greater or 125 percent of the 2A2C or 2A2B curve of the largest recloser on the circuit, whichever is greater.

On circuits without reclosers, the time dial setting should be set greater than the 200K fuse curve or the largest fuse on the circuit.

On circuits with fault currents lower than the feeder low set instantaneous relay setting, the breaker recloser cycle will be:

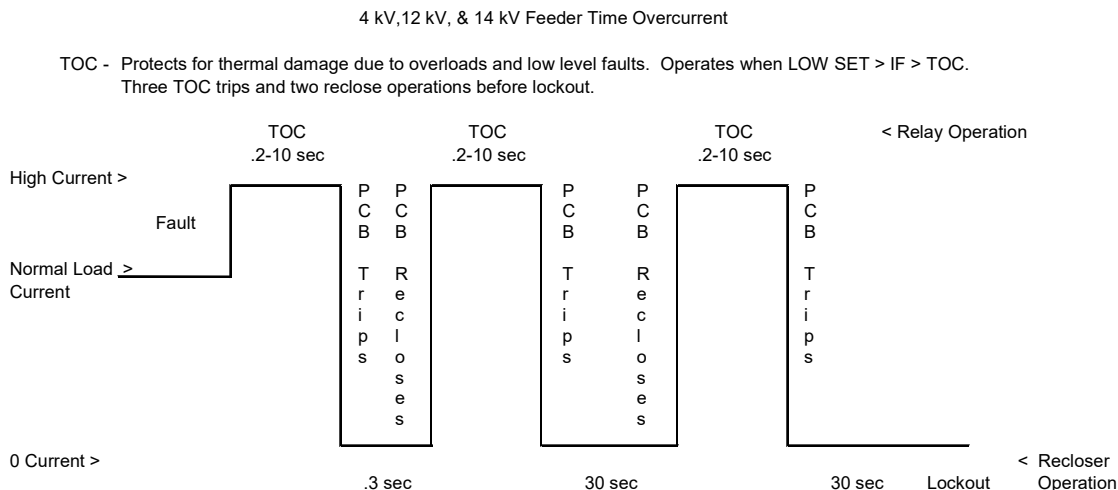

### 1.9.7.3 Feeder Low Set Instantaneous Relay Setting

On circuits where reclosers are in the main line, the relay will be set at 80 percent of the three-phase fault current or 85 percent of the single phase-to-ground fault current (whichever is lower) at the last main line recloser.

On circuits where reclosers are not located in the main line, the instantaneous relay will be set with the values given above at the normally open point of the circuit. However, the relay shall not be set lower than 2,000 amps on a 25 MVA or larger transformer. For transformers less than 25 MVA, relay should not be set lower than 1,200 amps.

14 kV & 12kV LOWSET Instantaneous Operating Sequence

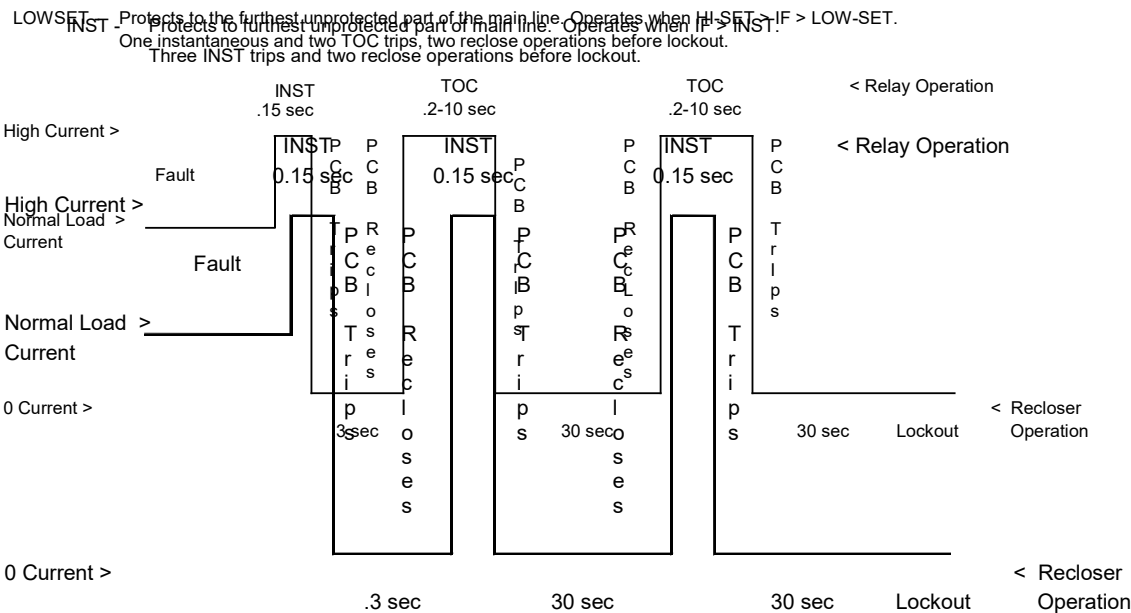

### 1.9.7.4 Transformer High-Set Instantaneous

This relay, used for 12 kV transformer protection, will allow instantaneous breaker clearing time of 0.1 second compared with 0.2 - 10 second clearing time of the feeder relay T.O.C. The breaker reclosing cycle will be:

12 kV Transformer HIGH SET Instantaneous Operating Sequence

HIGH SET - (Close-in fault relay) Protects the station transformer from damage due to high fault currents. Operates when  $IF > HIGH SET$ . Operation of the HIGH SET bypasses the TOC portion of the relay and allows three instantaneous trips and two reclose operations before lockout.

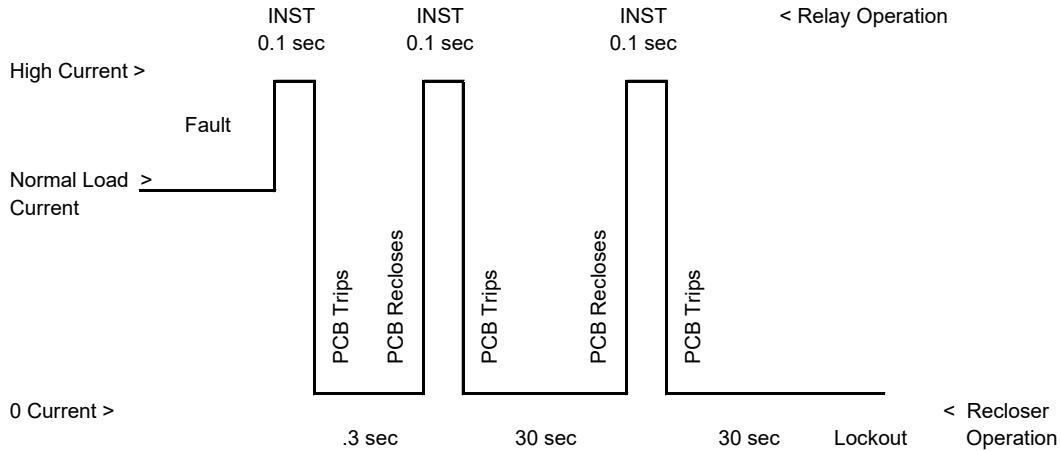

### Setting

This relay is normally set to under-reach the closest recloser on any circuit feeding from a particular transformer bus.

### Setting Guidelines

- (1) Set not less than 115 percent of the 1 $\phi$ -gnd or 3 $\phi$  fault (whichever is greater) at the closest recloser, but never more than (2) below.
- (2) Set not more than 70 percent of 1 $\phi$ -gnd bus fault.

If no reclosers are on the circuit or if all reclosers are type "L," the relay will be set at 4,800 amps.

On circuits with type "D" reclosers, where the 115 percent fault value exceeds 70 percent of the bus fault, the relay will be set at 70 percent of the bus fault. This value may overreach some type "D" reclosers, but this is not expected to cause any problems.

NOTE: The transformer high-set instantaneous relay is activated by current on the station bus; therefore, its setting is regulated by the circuit requiring the highest setting for the relay.

## 1.10 Shunt Capacitor Application Guidelines

This guideline covers some of the varied aspects of the capacitor program. Areas covered include data collection, control types, selection and sizing of banks, standard circuit configurations and fusing. Rules-of-thumb are given for capacitor placement of distribution circuits. Capacitor bank sizing and placement can be aided using the Distribution System Planning tools.

Information and procedures in this section represent current practices and guidelines and should not restrict other applications of capacitors. Changes to procedures should be made whenever suitable.

### **1.10.1 Capacitor Information Sources and Data Collection**

The primary source of data used in capacitor selection for power factor correction comes from a yearly circuit kW/kVAR charting program or from SCADA. The kW/kVAR charting is done by the Substation Construction and Maintenance Department. The survey is initiated by listing the circuits that need to be charted. The current practice is to obtain charts on all 12.47 kV and 13.8 kV circuits. The kW/kVAR charts normally cover a five-day period, including one weekend, during the Summer months. Circuit kW/kVAR charts may be obtained at times other than Summer months, if needed. Another source of information is a daily report generated by the Operations Department. This report is a list of the kW, kVAR, and power factor at most 12.47 kV and 13.8 kV substations.

The Electric Meter Department keeps records on capacitor bank controls. This information includes the operation count and measured current at the time of an annual maintenance check. This information is used to check the activity of a current controlled bank and to make control setting changes as necessary.

### **1.10.2 Control Types and Combinations**

Each type of capacitor bank has its own operation characteristics. For maximum benefit on a circuit, combinations of bank types are normally selected. The two types of capacitor banks that are presently used are discussed below. More than one of the same type of bank can be used on a circuit. Voltage levels are always improved by the installation of capacitor banks of any type or combination.

- 1) Fixed Only - This type bank is used for power factor and minor voltage correction on circuits where it is uneconomical to install switched banks. This includes most of the 4.16 kV system.
- 2) Switched and Fixed Combination - This combination is used on circuits that require power factor correction, but where voltage drop is not a large problem



or is compensated for by means other than voltage-controlled capacitors. This is the standard configuration for 12.47 kV and 13.8 kV circuits.

### **1.10.3 General Location and Sizing Guidelines**

#### Location of Grounded-Wye Connected Banks

Grounded-wye connections give the maximum current through the fuse when a capacitor is faulted for positive fuse clearing. However, capacitor banks using grounded-wye connections are susceptible to high-fault currents that can cause capacitor tanks to rupture. The capacitor protecting fuse must be coordinated with tank rupture curves.

As a rule-of-thumb, capacitor banks should only be installed where the maximum fault current does not exceed 5,000 amps phase-to-ground. This practice ensures fuse operation before tank rupture. If the fault current exceeds 5,000 amps, current limiting fuses would have to be used or an ungrounded-wye connection.

#### Location for Ungrounded-Wye Connected Banks

Ungrounded-wye connections are used on the 13.8 kV delta system. A delta connection can also be used on this system. By using an ungrounded-wye connection, fault currents are limited to 300 percent of normal bank current by the impedance in the other two-phase legs. Limiting the fault current enables placement of the capacitor bank almost anywhere on the distribution circuit, without regard for fault current levels. Using a delta-connected capacitor bank would require observance of the 5,000 amp fault current limit to prevent tank rupture.

#### Fixed Banks

Fixed capacitor banks are used in two ways. Fixed banks can be used with switched banks. In this case, the capacitor bank should, ideally, just cancel the reactive load at its yearly minimum level. However, in practice, this goal is difficult to achieve and a larger bank size is usually selected. This may produce a leading power factor at low loads. A slightly leading power factor has not been a major problem, but should be avoided if possible.

Yearly minimum circuit reactive load can be estimated by dividing the minimum kVAR value from the kW/kVAR chart by the total current value at the peak of the same cycle, and multiplying by the minimum yearly peak current for the circuit.

$$kVAR_{\text{Min}} = \frac{(kVAR_{\text{Chart Min}})(\text{Load Book Min. Yearly Current})}{(\text{Max. Total Current})}$$

On an evenly loaded feeder with switched banks, the fixed bank should be located with 30 percent of the reactive load beyond it. (This assumes a minimum to maximum kVAR ratio of about 3.33 and reactive load factor of 50 percent.) An evenly-loaded feeder has its load evenly distributed along the circuit.

The second use of fixed banks is when they are the only types on a circuit, as with most 4.16 kV feeders. In this case, capacitors are sized to about 60 percent of the maximum yearly kVAR circuit load.

On circuits with evenly distributed load, the capacitors should be located with 30 percent to 40 percent of the reactive load beyond the capacitor bank. Voltage problems may sometimes require the location of capacitors closer to the end of the line. This location is a compromise between minimum energy and demand losses. The section on permissible voltage rise and flicker should be consulted for the methods to ensure that the bank does not raise the voltage above acceptable limits.

On circuits with uniformly decreasing distributed loads, a capacitor bank should be located with 50 percent of the reactive load beyond it.

Capacitor banks can magnify harmonics on a circuit due to resonance with the circuit impedance. If harmonics become a problem, moving the capacitor bank location one or two spans up or down line should remedy the problem.

### Switched Banks

Switched banks are used to add capacitive VARs in discrete steps, as required to compensate for reactive load above the yearly minimum. On an evenly loaded feeder where one switched bank is required, it is normally located with 50 percent of the peak reactive load beyond it as a compromise between the minimum energy and demand losses.

The quantity of switched capacitive kVAR that needs to be installed on a circuit can be determined from the Summer kW/kVAR charts. The peak kW and kVAR values are scaled to reflect the Summer peak value. The following formula is used to calculate the amount of switched kVAR needed on a circuit.

$$\text{Switched } kVAR = kVAR_{\text{PEAK}} - kVAR_{\text{FIXED}} - (kW_{\text{PEAK}}) \left( \tan \left( \cos^{-1} (PF) \right) \right)$$

Where: Switched kVAR = Switched kVAR needed

$kVAR_{PEAK}$	=	Peak kVAR from chart
$kVAR_{FIXED}$	=	Fixed kVAR on circuit
$kW_{PEAK}$	=	Peak kW from chart
PF	=	Required power factor

Since capacitors are installed in discrete increments, when the calculated kVAR falls between standard bank sizes, the larger capacitor bank size is usually installed. The following example demonstrates this method.

The calculated switched capacitance needed is 485 kVAR. This falls between the standard capacitor bank sizes of 450 kVAR and 600 KVar; therefore, the bank size to install should be the larger of the two sizes, or 600 kVAR.

The switched bank on-and-off values are determined from the kW/kVAR chart and loadflow analysis of the circuit. Since chart values are metered at the substation, the on/off settings must be ratioed to determine the settings needed at the capacitor bank location.

#### **1.10.4 Multiple Switched Banks**

For the circuit under consideration, the number of switched banks needed may also be determined at this time. More than one switched bank may be needed if voltage problems are caused by a large bank switching or the reactive daily load curve is fairly steep, as on most residential feeders. The daily reactive load curve will have the same slope whether the capacitor banks are on or off. Therefore, more than one bank may also be needed to prevent a leading power factor at non-peak times and still maintain a desirable power factor at peak loads.

Keys Points for Multiple Switched Banks:

When more than one switched bank is installed on a circuit, the bank farthest from the source is set to turn on first and to turn off last. This prevents cycling of other switched banks. When installing any type of switched bank, flicker caused by switching operations and net voltage rise (after other regulating devices have operated) must be held to acceptable levels.

When multiple switched banks are used in series on a circuit, the banks should be located a minimum of 800 feet apart to minimize inrush current.

#### **1.10.5 Banks Installed at Other-Than-Rated Voltage**

Capacitors may be installed at a voltage lower than their rated voltage with a sacrifice in effective kVAR.

$$\text{Effective kvar} = \frac{(\text{Installed Voltage})^2}{(\text{Rated Voltage})^2} \times (\text{Rated kVAR})$$

As an example, 7,960 volt rated capacitors would have an effective kVAR of about 82 percent of their rated kVAR when operated at 7200 volts.

### 1.10.6 Calculation of Flicker and Net Voltage Rise

Although load has some effect on voltage rise and flicker due to capacitors, the effect is minimal and may be neglected. Both net voltage rise and flicker are calculated using the same equation; however, there is a difference in the way it is applied. Following capacitor switching and after all voltage regulation devices have operated, the net voltage rise at the capacitor bank may be approximated using the following equation:

$$\% \text{ Rise} = \frac{(kVAR)}{(10 \times kV_{L-L})} \times X \times d$$

Where:        kVAR = Capacitor bank size  
              d    = Miles from regulated bus to installation  
              kV<sub>L-L</sub> = Line to line voltage  
              X    = Reactance of source up to installation of  
                      capacitors in ohms/mile

This method assumes that a regulator will change taps to hold its output voltage constant and, therefore, the net rise anywhere beyond the bank will be due to a linear rise from the regulator to the bank. Net voltage rise anywhere between the bank and the regulators may be approximated by superimposing the feeder voltage profile. Flicker may be calculated using the same equation.

A regulator, when responding to a rise or fall in voltage or load, will not respond instantly and may have a delay of 30 seconds or more. A switching capacitor will create an instantaneous voltage change, not only on the wire, but also across the regulator, on the source side wire back toward the substation, on the substation bus, etc.

### 1.10.7 Pitfalls to Avoid

The complete distribution circuit should be analyzed properly. Series regulators, although they can hold load side voltage constant, have no control over source side voltage. Shunt capacitors, whether controlled or fixed, will produce an uncontrolled voltage rise on the source side of regulators. Care should be taken to ensure voltage levels or voltage fluctuations do not exceed Public Service Commission rules. Voltage charts, hand calculations, and computer routines are available to determine voltage and voltage rise at various points on a distribution circuit.

Whether installing similar or multiple types of capacitor controls on the same circuit, care must be taken so the interrelationships between controls will not cause false operations.

## **1.11 Distribution Automation**

### **1.11.1 Introduction to Distribution Automation**

Because Distribution Automation is in its formative stages, this write-up will:

- 1) Define Distribution Automation
- 2) Explain the distribution system
- 3) Outline the electric operation
- 4) Relate how DA can be used

### **1.11.2 Definition of Distribution Automation**

According to the Institute of Electrical and Electronic Engineers (IEEE), Distribution Automation refers to a system that enables an electric utility to monitor, coordinate, and operate distribution components in a real-time mode from remote locations. This includes secondary functions such as load management and automated meter reading (AMR).

Distribution Automation is a phrase that covers a wide range of electric distribution functions. A list of these functions includes:

- 1) Automated VAR (capacitor) control

- 2) Automated meter reading
- 3) Automated feeder switching and/or automated feeder reconfiguration
- 4) Automated line measurements and monitoring, such as line voltage and currents at critical points on the feeders
- 5) Automated voltage regulation
- 6) Automated or central load profiling

Most functional areas of distribution automation can be worked into an overall scheme as individual modules. By so doing, each module can be justified on its own merit. Modules can be added in the order most beneficial to the utility.

Parts of the plant required for Distribution Automation will be common to all or several modules. Communication links are good examples of plants that will be common to all modules.

The general goals of Distribution Automation are as follows:

- 1) Reduce cost
- 2) Improve service reliability
- 3) Provide better customer service and relations
- 4) Enhance government relations

### **1.11.3 Benefits of Distribution Automation**

A Distribution Automation System enhances the efficiency and productivity of a utility. It also provides intangible benefits such as improved public image and market advantages. The expenditure for distribution automation is customarily justified economically by the deferral of a capacity increase, a decrease in peak power demand, or a reduction in O&M expenditures.

Each Distribution Automation project, or module, should be evaluated to determine the cost of functions that could provide the desired benefits. Identifying and quantifying the expected benefits are important in developing the system design.

Some benefits are difficult to quantify. An enhanced public image from shortened restoration time during emergency conditions and better information for planning are examples of benefits that cannot be readily quantified, but are high priorities with utilities, regulatory authorities, and customers. Value of service models can be developed to aid in quantifying the benefits of shortened restoration times.

Some of the leading prospects for expecting net benefits from Distribution Automation are utilities which:

- 1) Will require additional generation, transmission, or substation facilities or circuit capacity
- 2) Have areas and loads which require high reliability
- 3) Have areas with diverse loads
- 4) Have areas with unusually high losses
- 5) Have areas with significant voltage problems
- 6) Have many remote or inaccessible meters
- 7) Have a high rate of turn on/turn off requests

The installation of a distribution automation system (DAS) requires a large capital investment. A DAS can be installed in stages to meet the changing needs of an area and/or to spread out the capital investment over several years. How the equipment will be integrated into the completed system is a critical consideration when specifying equipment for the initial modules. The DAS interface with other information systems is an important issue.

#### **1.11.4 A Modular Approach**

Any Distribution Automation System can be thought of as having three distinct modules:

- 1) Substation automation
- 2) Feeder automation
- 3) Customer location automation

These modules can be further broken down into sub-modules (e.g. capacitor control). A brief discussion of each of these general modules follows.

##### **1.11.4.1 Substation Automation**

This module includes supervisory control of circuit breakers, load tap changers (LTCs), regulators, and substation capacitor banks. The supervisory control function cannot be done effectively without remote data acquisition.

By controlling circulating currents and improving voltage and VAR profiles, additional capacity can be realized. Real-time data can be used by the utility to minimize the loss of life of substation transformers caused by overloading. If the utility can postpone capital expenditures for additional capacity, the savings can be readily quantified.

Operation and maintenance (O&M) cost will generally be lower as a result of reductions in the time required to remotely operate breakers, LTCs, etc. Additional savings result from remote relay testing and setting, data collection and analysis, and testing of data logging devices. These savings are realized because fewer trips to the substations are required.

Improved restoration time can result in both utility and consumer savings. Consumer savings are in the form of avoided outage costs. An example is a restaurant, which must close when the power is out of service. Utility savings may be in the form of avoided complaints and legal costs. A distribution automation system should improve customer and governmental relations because it improves service reliability.

#### **1.11.4.2 Feeder Automation**

Feeder automation includes data acquisition and supervisory control of line equipment such as reclosers, regulators, capacitors, sectionalizers, and switches. Additionally, the utility can install remote monitoring equipment (e.g. fault indicators and analyzers).

Remote monitoring and switching to balance feeder loads can reduce losses. The reduced loss savings result in fuel cost savings that are passed on to the customers. Switching schemes can be either automatic or semi-automatic. By better utilization of existing substation and feeder facilities, the need for additional generation, transmission, substation, and feeder facilities may be deferred.

Due to the reduced time required for the following functions, O&M cost will be reduced:

- 1) Fault location and isolation
- 2) Feeder reconfiguration
- 3) Service restoration
- 4) Switching operation
- 5) Recloser setting and testing
- 6) Data collection
- 7) Capacitor bank inspection

The ability to isolate and restore service quickly when an outage occurs results in increased revenues. The value of service to the customer must also be considered.



### 1.11.4.3 Customer Automation

Automation at the customer's location includes the ability to remotely read meters, program time-of-use (TOU) meters, connect and disconnect services, control customer loads, and send TOU signals.

Demand Side Management (DSM) techniques, such as TOU incentives and direct load control, can result in reduced customer peak demands. Therefore, the need for facility additions may be deferred.

Operation and maintenance costs are lowered through reduced labor requirements for meter reading, reprogramming of meters, service connects and disconnects, and processing of customer claims.

As a result of improved tamper detection, an increase in revenues will be realized. Additionally, the real-time load data at the actual customer location provides better information for planning and engineering.

### 1.11.5 Distribution System Representation

There are two types of distribution architectures currently in use. The radial system is the predominant type. A secondary network is used in the downtown area. Automation of our system must address equipment needs for both types of systems. Emphasis will be given to automation of the radial system, since it is far more extensive than the network system.

#### 1.11.5.1 Radial System

A schematic illustration of a radial distribution system is provided in the figure to the right. The radial system provides a single path of power flow from the distribution substation to each customer. All system elements from the distribution substation to the secondary circuits and services are connected and operated in a series, or radial, configuration. Protective operating and safety practices are predicated on the radial character of this system. For example, when a

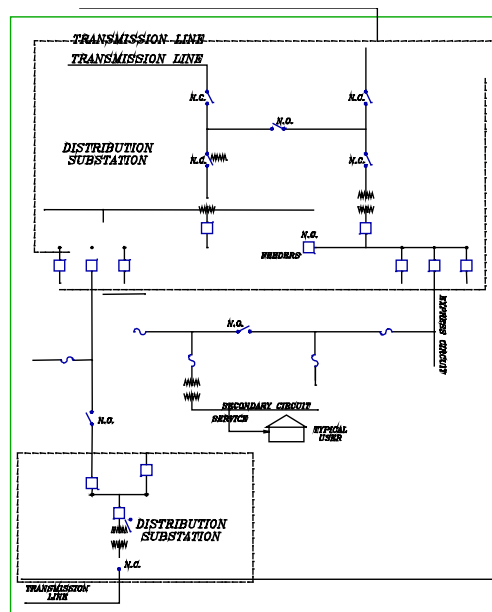

fuse opens, all lines on the load side of that fuse will be de-energized.

### 1.11.5.2 Primary Network System

A primary network system differs from a radial system only in that one or more of the primary circuits tie or loop between substations, as illustrated in the figure to the right. The tie or loop circuits have two sources of power in normal operation; therefore, they may require special protective relaying equipment. When one element, such as a fuse or breaker, opens, no elements of the circuit are de-energized.

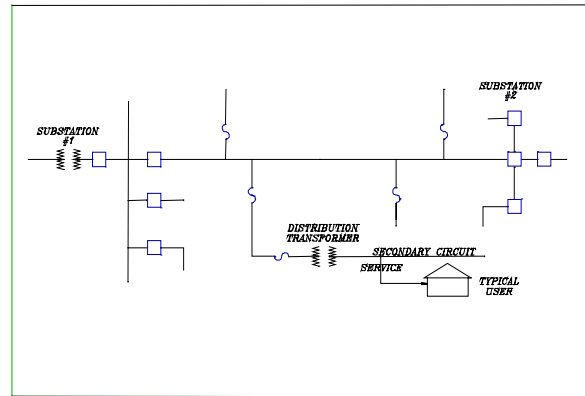

Secondary voltage cables (120/208 volt) are tied together from vault to vault in the downtown network area. This procedure creates a secondary network (not shown).

### 1.11.5.3 System Operations

In order to come to grips with the impact of DA, we need to examine the functions of system operations closely. Distribution operations, load dispatch, and substation operations are all functions of interest to Distribution Automation. Load Dispatch has primary responsibility for day-to-day operations of the transmission system and substation breakers. They interface with trouble/distribution operations dispatchers and substation operations. Distribution operations interfaces with customer services. The distribution operator has responsibility for dispatching troublemen in response to trouble calls. A major part of the responsibility, and one that has particular significance for DA, is safety clearance and tagging. The load dispatcher has authority over clearance procedures. These procedures permit lines and equipment to be taken out of service for maintenance, extensions, and repairs. When clearance is given, tags placed by distribution operations personnel are used to denote the switches or breakers involved in providing the clearance. These devices cannot be operated until the tags are removed. After work is complete and required safety assurances are received, only trouble operators can remove the tags. Load dispatchers control the distribution SCADA system, which provides remote control and monitoring of substations.

### **1.11.6 Future Implications**

With the advent of distribution automation, some design practices for the distribution system will change. The way the distribution system operates will also change. For example, the ability to reconfigure circuits automatically will allow system optimization or service restoration. Uniform conductor sizes will be used to provide maximum flexibility.

Functions, such as loadshedding and VAR requirements, can be addressed by feeder sections rather than by total circuits. Substation and feeder load balancing, fault isolation, and some service restoration can be done without operator intervention. This will be made possible by automatic control of feeder sectionalizing and tie switches.

Much existing equipment will be displaced. Conventional recorders, meters, and SCADA remote terminal units will become obsolete. The number of conductor types used will probably be reduced. Safety procedures, reporting procedures, maintenance procedures, and data acquisition will change drastically.

Additionally, distribution automation will impact the utility system control hierarchy. Control and supervision of a distribution system with DA may reside with one or more Distribution Dispatch Centers. These may be located in divisions such as service center territories or in the Energy Control Center. These dispatch centers must integrate with Load Management Controllers and Metering Data Centers.

#### **1.11.6.1 Equipment to be Controlled and/or Monitored**

The equipment to be controlled and/or monitored is grouped into functional categories in the table below. Following is a list of equipment the DAS may control and/or monitor:

- 1) Capacitor banks
- 2) All line banks would probably be controlled with "fixed" banks becoming a thing of the past or, at least, redefined
- 3) Substation capacitors, switched in stages
- 4) Customer Premise Equipment (CPE)
  - a) Revenue meters
  - b) Disconnect devices

- c) Load control switching
  - d) Customer monitoring equipment
  - e) Customer load profile equipment (such equipment may exist in the substation and on feeders also)
- 5) Protective devices
- 6) Fault detection devices
- 7) Feeder sectionalizing devices
- 8) Relaying equipment (e.g. automatic reclosing, lockout relays, etc.)
- 9) Circuit breakers
- a) Substation Bus-tie
  - b) Feeder
  - c) Substation Transformer
- 10) Voltage regulators
- 11) Substation switches (e.g. motor operated disconnects)
- 12) Sensors
- a) Current Transformers
  - b) Potential Transformers
  - c) Transformer LTC position indication
- 13) Alarm contacts
- a) Underfrequency devices
  - b) Transformer low oil level
  - c) Loss of pump flow
- 14) Auxiliary relay contacts (e.g. transformer cooling stages in service, etc.)
- 15) Transducers
- a) Current
  - b) Voltage
  - c) VAR
  - d) Watt
  - e) Transformer temperatures

## **2.1 Load Growth Forecasting**

### **2.1.1 Regression Analysis**

Regression analysis is used to forecast load growth on distribution substations for both winter and summer conditions. The regression analysis method has been used for many years and generally yields good short-term (five years or less) load growth projections. Projections from six years out become progressively less reliable because trending is a linear approximation and cannot account for load saturation in areas of the system.

### **2.1.2 Procedure**

To perform regression analysis forecasting, the following steps are taken:

The substation's last ten years of peak load data for winter and summer is used. The peak loads are non-coincidental to the system peak. This load data is obtained from system operations.

Regression analysis is performed on a substation using an in-house program.

Analyses are run on all substation transformers.

### **2.1.3 Grouping of Substations**

In some cases, substations are grouped together to obtain a load growth for a larger area of the system. This is done when individual substation growth rates seem abnormally high compared to the previous year. An abnormal growth rate may be attributed to load transfers between substations.

When a load growth has been obtained for an area, that load growth is broken down between substations used in the analysis to obtain growth rates for each substation. Several regression analysis runs are needed to obtain these growth rates.

### **2.1.4 Equating Growth Rates to the Corporate Forecast**

The growth rates for all substations are totaled. Each substation's load growth rate is divided by the total growth rate to obtain a percentage of the system

growth expected by the substation. This process is carried out for all future years needed.

The corporate projected load growth, in MW, obtained from the Forecasting and Load Research Department, is divided among the various substations based upon the percentage obtained from the above process. System Operation Support supplies substation peak load data. Power factors are calculated from this data. The projected MW loads are converted to MVA using the appropriate power factor. The projected substation loads obtained are for system coincidental peak conditions.

### **2.1.5 Non-Coincidental Substation Growth Projections**

An average coincidence factor is obtained for each substation. The average coincidence factor is based on the current and previous year's coincidence factors. Using the coincidence factor, an approximation of the substation's non-coincidental peak demand load can be calculated.

Coincidence factors for each substation, relative to system peak, are calculated from the previous two years load data. Using the coincidence factor, an approximation of the substation's non-coincidental, peak demand load can be calculated.

## **2.2 Distribution Analysis**

All distribution analyses are performed using the current Distribution System Planning tools. Refer to the application reference material for instructions on specific modules.

Typical analyses performed on the electric distribution system include:

- Load Flow
- Short Circuit
- Capacitor Application
- Optimal Switching
- Substation transformer and circuit outage contingencies

### **2.2.1 Circuit Phase Balancing**

Circuit phase balancing may be requested for various reasons. Requests for phase balancing generally come from the Systems Operations Department. Load balancing is also done when circuit studies indicate a need for it.

## 2.2.2 Downtown Network Analysis

There are presently five network systems in the downtown Louisville area. The networks are listed below with the voltage levels they serve and the number of primary feeders serving each network. Primary voltage to all networks is 13.8 kV.

<u>Network Name</u>	<u># Circuits</u>	<u>Secondary Voltage</u>
Madison	5	120/208 & 277/480
Magazine	5	120/208 & 277/480
Riverfront East	5	277/480
Riverfront West	5	277/480
Waterside	7	120/208 & 277/480

Riverfront East and West are fed from the Waterside Substation. City of Louisville Ordinance number 239-1955 requires all distribution facilities be underground in the designated ordinance area.

### 2.2.2.1 Networks Systems

#### 120/208 Volt Network System

There are three 120/208-volt distribution network systems that serve the downtown area. The networks are served by a total of 17 primary feeders at 13.8 kV. The three networks are not interconnected at any voltage level. A specific network serves specific vaults depending upon their location. Vaults are never served by primary feeders from different networks. Primary circuits serving a multiple transformer vault are not duplicated within the vault.

The 120/208-volt network is a secondary grid system connecting multiple vaults together through secondary street mains (cables). Each network is designed to withstand the loss of one primary feeder during peak load. Customers on the network should not experience low voltage or service interruption due to the loss of a single primary feeder serving the network.

Network distribution analyses are performed using a network loadflow program. The program and databases currently reside on the VAX computer system.

### Secondary Street Mains

As previously mentioned, 120/208-volt network vaults are tied together via street mains. These mains are tapped at various locations to serve light load customers. Service connections are made in manholes, vaults, or small service holes.

All secondary street mains are single-conductor cables. Secondary street mains range in size from 4/0 to 500 kcmil copper. Determination of the cable size is primarily based on the required current carrying capacity. The required current-carrying capacity is determined under primary single contingency conditions. In some instances, voltage drop may dictate the size of the cable used.

### 277/480 Volt Spot Networks

Spot networks are stand-alone vaults in the downtown area. Secondary street mains do not typically connect the vaults. Each vault is designed to withstand the loss of a single transformer or primary feeder. A vault typically serves only one customer or building. Primary feeders are not duplicated in any vault.

There are two network systems dedicated to serving only 277/480-volt spot networks. The primary feeders serving the three 120/208-volt networks also serve some 277/480-volt spot networks.

Analyses of 277/480-volt spot networks are done by hand or through the use of spreadsheets.

### **2.2.2.2 Vaults**

Vaults generally contain one to five network transformers and associated network protectors. The network transformers range in size from 300 kVA to 1,000 kVA on the 120/208-volt network and from 750 kVA and 2,000 kVA in 277/480-volt spot networks.

### Vault Location

The location of a vault is determined primarily by the location of the customer it will be serving. This is particularly true for customers requesting 277/480-



volt service. Street mains may serve small customers needing 120/208-volt service, unless their load is significant enough to require a vault. If a new 120/208-volt vault is needed to maintain the reliability of a network due to serve a new customer's load, the vault is located at the customers site.

#### Vault Primary Circuit Selection

Selection of primary circuits to serve vaults is based on availability of circuits in the area, circuit loads, and, in the case of the 120/208-volt network, circuits serving neighboring vaults. Primary circuits near the vault location should be considered first to minimize cost. Primary circuits that have the lightest loading, based on data obtained from the load data book, should be utilized first, if possible. A lightly loaded circuit may be blocks away from the location desired. In this case, it may be better to chose a circuit with heavier loading, but closer to the vault to save on cost. For 120/208-volt networks, it is necessary to select circuits that are not serving neighboring vaults if possible. Since most vaults have multiple transformers, this is not always possible. Efforts should be made to minimize the number of vaults being served by a single primary feeder in the area. This is important in maintaining system stability under single contingency conditions. In some instances, network loadflow analyses will be required to determine the optimum circuits for normal and single contingency conditions.

## **2.3 Data Maintenance and Storage**

The members of the Distribution Planning group will maintain the databases that contain equipment and model files for each of the kV subclasses. The Reliability Engineers and Distribution Operations Department will have access to a copy of the database files for analysis.

## **2.4 General Project/Task Information**

### **2.4.1 Sources**

Distribution Planning projects/tasks may be proposed or requested by various sources. The types of requests will vary from department to department. Some requests may take only an hour to complete while others may take days. Distribution Planning personnel should review all proposals for changes in the configuration of the electric distribution system or its operating characteristics.

#### **2.4.1.1 Responsibilities**

Primary responsibilities of the Distribution Planning personnel are:

- Planning tools training
- Database creation and maintenance
- Load data gathering
- Identification of future circuit and substation ROW property needs
- Contingency analysis of distribution circuit or substation transformer loss
- Identification of needs for portable substation capacity
- Review of the electric distribution system
- Circuit phase balancing
- kVAR planning (capacitor needs)
- Wire sizing and circuit reconductoring
- System modeling
- Downtown network analysis
- Protection coordination for new circuits
- Circuit loading analysis
- Circuit selection for new loads
- PSRT support
- Circuit outage analysis during storms
- Downtown network analysis

Primary responsibilities of the ESD Reliability Engineers are:

- Fault current/motor starting calculations
- Overloaded tap recommendations
- Customer complaints

Shared Responsibilities:

- Technical organization support
- Primary voltage regulation analysis
- Switching and load transfer recommendations
- System power quality issues
- Feeder circuit protective coordination
- Circuit phase balancing

## 3.1 General Design Standards

The majority of the primary circuits are constructed overhead in a delta or grounded-wye configuration. Some overhead circuits are fed by an underground cable to the main line outside the substation. This practice was initiated to minimize congestion near the substation. Some load is fed underground, such as airports, shopping centers, most new subdivisions, etc. Underground construction may also be used for highway crossings and other special cases.

Most Underground Residential Distribution (URD) is constructed single-phase. The majority of URD circuits are served from nearby overhead primary circuits. The URD system is arranged in an open-loop configuration. The open-loop system allows faster restoration of service in event of a cable failure.

Shunt capacitors are installed on overhead primary circuits. Several capacitor banks may be installed on one circuit. Some are fixed (continuously in operation) and others are switched via local controls (typically current control). Typical bank sizes run from 150 to 1,800 kVAR. On the 13.8 kV system, capacitors are connected ungrounded wye. For all other voltages, capacitors are typically connected grounded wye. Capacitors are not used on the URD system. A few substations employ capacitor banks within the substation.

Fuses are used on tap lines and at other strategic points along the feeders (e.g. where there is a wire size change).

On the radial system, under normal conditions, each substation and its associated circuits operate independently. However, there is dependence between substations and circuits because of the possible need for load transfers, circuit reconfiguration, service restoration, etc.

## 3.2 Distribution Transformers

### 3.2.1 Overhead

Single-phase distribution transformers, ranging from 5 kVA to 500 kVA, are installed on overhead primary circuits to serve loads. Residential services are primarily single-phase. One single-phase transformer can serve several homes. Three-phase loads are served by a three-phase transformer, by three single-phase transformers, or an open delta configuration of transformers.

### **3.2.2 Underground**

On underground circuits, padmounted transformers are used to serve the loads. Single-phase padmounts range from 10 kVA to 167 kVA in size, while three-phase padmounts range from 45 kVA to 3000 kVA.

### **3.2.3 Network**

These transformers range from 300 kVA to 2,000 kVA. They are three-phase transformers connected delta primary with a grounded-wye secondary.

## **3.3 Secondary Circuits and Service Agreements**

Typically, residential service to individual homes is 120/240-volt single-phase three-wire. One or more secondary circuits run from each transformer. Service conductors for each home are connected to a secondary circuit. A kWh meter is located at each home.

The simplest service arrangement consists of a single distribution transformer installation that is supplied radially from an overhead circuit or a URD circuit. Revenue metering is provided at the transformer location or at the customer's premises. The customer provides the secondary connections from the transformer to the service entrance equipment.

Residential service to multi-family dwellings is either 120/240-volt, single-phase or 120/208-volt, three-phase, four-wire depending upon individual requirements. Normally, a distribution transformer is dedicated to serve the building and may be pole mounted or padmounted. A secondary circuit runs from the transformer to a group meter panel that contains a meter for each individual customer.

Service arrangements for commercial and industrial customers vary widely because of the range of load and service requirements. The service voltage is either 120/208-volt or 277/480-volt (grounded wye) three-phase, four-wire. Some commercial and industrial customers, especially older installations, are supplied with 480-volt or 240-volt delta. A few commercial and industrial customers are fed by 120/240-volt single-phase service.

Some commercial and industrial customers have a primary voltage dual-feed arrangement. Two primary circuits are provided at the transformer location. Throw-over switching is used to connect the load to an alternate circuit in the event an outage occurs on the normal feed. Switching can be manual or automatic. These dual-feed type installations are normally reserved for critical loads such as hospitals.

### 3.4 Underground Cable Ampacity Ratings

The tables in this section contain ampacity ratings for underground cables and overhead wires.

Ampacity tables are given for underground cable located in ducts and direct buried. The tables are taken from the IEEE-IPCEA Power Cables Ampacities data book. Tables are given for aluminum and copper conductors.

#### Single-Conductor Cables

The following parameters are used in determining ampacities for single conductor cables:

- 1) Earth Thermal Resistivity (RHO) = 90
- 2) Conductor Temperature = 90° C
- 3) Ambient Earth Temperature = 20° C
- 4) For residential and commercial applications, a load factor (LF) of 50 should be used
- 5) For industrial applications, a load factor of 75 to 100 should be used

To determine the appropriate table to use for an underground cable ampacity rating, the following guidelines are used for various underground cable conditions.

#### Single-Phase and Two-Phase Direct Buried Circuits

Use single-conductor, concentric-stranded, rubber-insulated cable buried tables.

#### Three-Phase Direct Buried Circuits

Use triplexed, concentric-stranded, rubber-insulated cable buried tables.

#### Circuits in Ducts Encased in Concrete

Use triplexed, concentric-stranded, rubber-insulated cable in duct tables.

#### Three Conductor Cables

The following parameters are used in determining ampacities for three-conductor cables.

- 1) Earth Thermal Resistivity (RHO) = 90
- 2) Conductor Temperature = 80° C

- 3) Ambient Earth Temperature = 20° C
- 4) For residential and commercial applications, a load factor (LF) of 50 should be used
- 5) For industrial applications, a load factor of 75 to 100 should be used

Cable ampacity tables are provided for 8 kV and 15 kV rated copper conductor cables. The 8 kV tables are used for the 4.16 kV distribution system.

Interpolation may be used to approximate ampacities for various numbers of circuits from these tables.

<b>THREE-CONDUCTOR SHIELDED SOLID-TYPE IMPREGNATED PAPER INSULATED CABLE IN DUCTS – COPPER CONDUCTOR RHO 90</b>						
<b>1 CABLE IN DUCT BANK 15 kV 80 C CONDUCTOR 20 C AMBIENT EARTH</b>						
<b>SIZE</b>		<b>50 LF</b>		<b>75 LF</b>		<b>100 LF</b>
4		116		112		106
2		151		145		138
1/0		199		190		179
2/0		224		214		202
4/0		294		279		262
250		324		307		288
350		394		372		348
500		481		453		422
750		598		560		519
1000		690		644		594
<b>3 CABLES IN DUCT BANK 15 kV 80 C CONDUCTOR 20 C AMBIENT EARTH</b>						
4		8		99		90
2		140		127		116
1/0		182		165		149
2/0		205		186		168
4/0		267		240		215
250		294		263		236
350		355		316		282
500		430		381		338
750		529		466		411
1000		606		530		465
<b>6 CABLES IN DUCT BANK 15 kV 80 C CONDUCTOR 20 C AMBIENT EARTH</b>						
4		98		86		75
2		126		110		96
1/0		163		141		122
2/0		183		158		137
4/0		237		202		175
250		259		221		190
350		311		263		226
500		374		314		269
750		456		380		324
1000		517		429		364
<b>9 CABLES IN DUCT BANK 15 kV 80 C CONDUCTOR 20 C AMBIENT EARTH</b>						
4		93		80		69
2		119		102		88
1/0		154		130		112
2/0		173		146		125
4/0		222		186		159
250		243		203		173
350		290		241		204
500		347		287		242
750		422		345		290
1000		477		388		325

<b>TRIPLEXED CONCENTRIC STRANDED RUBBER INSULATED CABLE IN DUCTS COPPER CONDUCTOR CONCENTRIC STRAND RHO-90</b>								
<b>1 CIRCUIT 15 kV - 90 C CONDUCTOR 20 C AMBIENT EARTH</b>								
<b>SIZE</b>		<b>30LF</b>		<b>50LF</b>		<b>75LF</b>		<b>100LF</b>
2		178		173		164		155
1/0		233		225		214		201
2/0		267		257		243		228
4/0		349		336		317		295
250		384		369		347		323
350		465		445		418		387
500		566		540		504		465
750		698		663		616		565
1000		797		755		697		637
<b>3 CIRCUITS 15 kV - 90 C CONDUCTOR 20 C AMBIENT EARTH</b>								
2		170		158		142		128
1/0		222		205		184		165
2/0		253		233		208		186
4/0		330		302		268		238
250		362		330		292		259
350		436		396		349		308
500		528		476		417		366
750		647		579		503		439
1000		735		654		564		490
<b>6 CIRCUITS 15 kV - 90 C CONDUCTOR 20 C AMBIENT EARTH</b>								
2		160		141		121		105
1/0		207		182		155		133
2/0		235		206		175		150
4/0		305		264		223		190
250		334		288		242		207
350		401		344		287		244
500		482		410		340		288
750		585		493		406		343
1000		660		552		452		380
<b>9 CIRCUIT 15 kV - 90 C CONDUCTOR 20 C AMBIENT EARTH</b>								
2		154		133		112		95
1/0		199		171		142		121
2/0		226		193		160		136
4/0		291		247		204		172
250		319		269		221		187
350		381		319		262		220
500		457		380		309		259
750		553		455		368		307
1000		621		508		408		340



<b>SINGLE CONDUCTOR CONCENTRIC STRANDED RUBBER INSULATED CABLE BURIED ALUMINUM CONDUCTOR CONCENTRIC STRAND RHO-90</b>								
<b>1 CIRCUIT 3 CABLES 15 kV 90 C CONDUCTOR 20 C AMBIENT EARTH</b>								
SIZE		30LF		50LF		75LF		100LF
2		208		196		180		164
1/0		277		259		235		213
4/0		421		389		350		314
350		573		526		468		417
500		714		650		575		508
750		910		822		721		634
1000		1084		972		847		740
1500		1363		1213		1047		910
<b>2 CIRCUITS 6 CABLES 15 kV 90 C CONDUCTOR 20 C AMBIENT EARTH</b>								
2		205		190		171		154
1/0		272		250		223		199
4/0		412		374		330		292
350		559		504		440		386
500		695		621		537		468
750		884		783		672		582
1000		1050		923		786		678
1500		1317		1147		969		830

<b>TRIPLEXED CONCENTRIC STRANDED RUBBER INSULATED CABLE BURIED ALUMINUM CONDUCTOR CONCENTRIC STRAND</b>								
<b>1 CIRCUIT 15 kV-90 C CONDUCTOR 20 C AMBIENT EARTH</b>								
SIZE		30LF		50LF		75LF		100LF
2		157		154		151		147
1		179		176		172		167
1/0		204		201		196		191
4/0		302		297		289		280
350		400		393		383		369
500		487		478		464		447
750		604		591		574		552
1000		698		682		661		635
<b>2 CIRCUITS 15 kV-90 C CONDUCTOR 20 C AMBIENT EARTH</b>								
2		154		150		143		136
1		176		171		163		154
1/0		201		195		185		175
4/0		296		286		272		256
350		392		378		358		335
500		477		459		432		404
750		590		566		532		496
1000		681		652		611		567

<b>TRIPLEXED CONCENTRIC STRANDED RUBBER INSULATED CABLE IN DUCTS ALUMINUM CONDUCTOR CONCENTRIC STRAND RHO-90</b>								
<b>1 CIRCUIT 15 kV-90 C CONDUCTOR 20 C AMBIENT EARTH</b>								
<b>SIZE</b>		<b>30LF</b>		<b>50LF</b>		<b>75LF</b>		<b>100LF</b>
1/0		182		176		167		157
4/0		274		263		248		231
350		366		351		329		305
500		449		429		400		370
750		564		536		497		457
1000		656		621		574		525
<b>3 CIRCUITS 15 kV-90 C CONDUCTOR 20 C AMBIENT EARTH</b>								
1/0		173		160		143		128
4/0		258		236		210		186
350		344		312		275		243
500		419		379		331		291
750		523		468		406		355
1000		605		538		465		404
<b>3 CIRCUITS 15 kV-90 C CONDUCTOR 20 C AMBIENT EARTH</b>								
1/0		162		142		121		104
4/0		239		207		174		149
350		316		271		226		193
500		383		326		271		229
750		473		399		329		277
1000		544		455		373		314
<b>3 CIRCUITS 15 kV-90 C CONDUCTOR 20 C AMBIENT EARTH</b>								
1/0		155		133		111		95
4/0		228		193		160		135
350		300		252		206		174
500		363		302		246		206
750		447		368		297		248
1000		512		419		337		280

<b>SINGLE CONDUCTOR CONCENTRIC STRANDED RUBBER INSULATED CABLE BURIED COPPER CONDUCTOR CONCENTRIC STRAND RHO-90</b>								
<b>3 CIRCUITS 15 kV-90 C CONDUCTOR 20 C AMBIENT EARTH</b>								
SIZE		30LF		50LF		75LF		100LF
2		267		251		230		210
2/0		408		381		345		312
4/0		539		499		449		403
350		734		673		600		534
500		911		830		734		649
750		1155		1044		915		805
1000		1365		1225		1066		932
1500		1683		1497		1292		1123
2000		1941		1711		1465		1266
<b>3 CIRCUITS 15 kV-90 C CONDUCTOR 20 C AMBIENT EARTH</b>								
2		263		244		219		197
2/0		400		367		327		291
4/0		528		480		424		374
350		716		645		563		494
500		887		793		686		598
750		1122		993		853		739
1000		1323		1162		990		854
1500		1626		1415		1196		1025
2000		1870		1612		1351		1152

<b>TRIPLEXED CONCENTRIC STRANDED RUBBER INSULATED CABLE BURIED COPPER CONDUCTOR CONCENTRIC STRAND</b>								
<b>3 CIRCUITS 15 kV-90 C CONDUCTOR 20 C AMBIENT EARTH</b>								
SIZE		30LF		50LF		75LF		100LF
2		201		198		194		188
2/0		298		293		286		277
4/0		386		379		370		358
350		509		499		486		469
500		614		602		585		564
750		749		733		711		683
1000		849		830		804		771
<b>3 CIRCUITS 15 kV-90 C CONDUCTOR 20 C AMBIENT EARTH</b>								
2		198		192		183		174
2/0		293		283		270		254
4/0		379		366		347		327
350		499		480		454		426
500		601		578		545		509
750		731		701		659		613
1000		828		793		742		689

### 3.5 Overhead Wire Ampacity Ratings

The overhead wire ampacities table is taken from the Engineering Data and Engineering Practices data book maintained by Power Delivery Engineering.

**Overhead Wire Ampacities**

Conductor Size	Poly W.P. Cu	Bare H.D. Cu	Type "A" C.W.	Poly W.P. Al	Bare H.D. Al	A.C.S.R.	A.C.A.R.	Spacer Cable
6	127	127	140					
4	171	171	180	122				
2	230	230	240	170				156
1/0	309	309		230	230			216
2/0	360	360				270		
3/0	416	416		311		340		282
4/0	485	485						
123 kcmil							280	
195 kcmil							375	
336 kcmil				485	485	570		435
392 kcmil							590	
500 kcmil	788	842						
795 kcmil				840	845	970		747
840 kcmil							965	
1000 kcmil	1206	1300						
1272 kcmil					1130			

The following parameters are used in calculating the thermal limit ampacity rating for each wire:

- 1) 25° C ambient air
- 2) 50° C rise
- 3) Feet per second wind velocity
- 4) 75° C conductor temperature

## 3.6 Voltage Regulation

The following voltage regulations are mandated by the Public Service Commission "Rule V." (*Portions of "Rule V" that do not pertain to voltage have been omitted.*)

### 3.6.1 Rule V

#### Part 1

Each utility shall adopt a standard nominal voltage or standard nominal voltages, as may be required by its distribution system for its entire constant-voltage service, or for each of several districts into which the systems may be divided, which standard voltages shall be stated in every schedule of rates of each utility or in its terms and conditions of service.

#### Part 2

Voltage at the customer's service entrance or connection shall be maintained as follows:

- A) For service rendered primarily for lighting purposes, the variation in voltage between 5:00 p.m. and 11:00 p.m. shall not be more than five percent (5%) plus or minus the nominal voltage adopted, and total variation of voltage from minimum to maximum shall not exceed six percent (6%) of the nominal voltage.
- B) For service primarily rendered for power services, the voltage variation shall not at any time exceed ten percent (10%) above or ten percent (10%) below standard nominal voltage. Where a limited amount of lighting is permitted under these contracts, the entire load shall be considered power as far as voltage variation is considered.
- C) Where the utility's distribution facilities supplying customers are reasonably adequate and of sufficient capacity to carry the actual loads normally imposed, the utility may require that starting and operating characteristics of equipment on the customer premises shall not cause an instantaneous voltage drop of more than four percent (4%) of standard voltage, nor cause objectionable flicker in other customer's lights.

#### Part 3

Variations in voltage in excess of those specified, caused by the operation of power apparatus on customer's premises which require large starting currents

and affect only the user of such apparatus, by action of the elements and infrequent and unavoidable fluctuations of short duration due to system operation shall not be considered a violation of this rule.

Part 4

Greater variation of voltage than specified under this section may be allowed if service is supplied directly from a transmission line, if emergency service, or if in a limited or extended area in which customers are widely scattered or business done does not justify close voltage regulation. In such cases, the best voltage regulation shall be provided that is practicable under the circumstances.

**3.6.2 Nominal Voltage**

The adopted nominal secondary voltage level is **120 volts**. The voltage level at the customers' entrance is maintained between the minimum and maximum voltage levels given below. The voltage levels are based upon  $\pm 5$  percent of nominal.

Nominal voltage: 120 volts

Maximum voltage: 126 volts

Minimum voltage: 114 volts

On 277/480-volt secondary systems, the nominal voltage is **277 volts**. The voltage level at the customers' entrance is maintained between the minimum and maximum voltage levels given below. The voltage levels are based upon 5% percent of nominal for non-power customers. For power customers, 10% percent is allowable.

Nominal Voltage: 277 volts

Maximum Voltage: 290 volts

Minimum Voltage: 263 volts

### 3.6.3 Voltage Flicker

The following table contains the maximum allowable flicker limits adopted by Louisville Gas and Electric Company.

**Maximum Allowable Flicker**

Location	Allowable Flicker
Customer (residential)	5 - 6 %
Secondary	4 %
4.16 kV Primary	2 %
12.47 kV Primary	2 %
13.8 kV Primary	0.5 - 1 %
Substation Bus	0.5 %
Power Customers	10 %
Commercial	2 %

## 3.7 Capacitors

Capacitor banks vary in kVAR size and type. Capacitor banks are installed on most distribution circuits throughout the system. When a majority of distribution circuits from a substation are completely underground, capacitor banks are installed in the substation. In these cases, the capacitor bank installation is handled by Substation Engineering.

### 3.7.1 Power Factor

For distribution planning, a power factor of 0.99 has been adopted as the goal at the substation distribution bus under peak load conditions. Capacitor banks on distribution circuits are sized to achieve this power factor level. This power factor

level helps the transmission and distribution system maintain adequate voltage levels during peak load conditions and reduces system losses.

### **3.7.2 Capacitor Bank Types**

Two types of capacitor banks are used on distribution circuits: fixed banks and switched banks.

Fixed Bank: This type of bank is used to supply kVAR to maintain a power factor of 0.99 during off-peak conditions. This type of bank remains on-line continuously.

Switched Bank: This type of bank is used to supply kVAR only during heavy load conditions to maintain a power factor of 0.99. This type of bank is switched off- and on-line using local controls.

The combination of these two bank types on a distribution circuit provides a way to maintain a relatively constant power factor during all seasons of the year and all hours of the day.

### **3.7.3 Standard Capacitor Bank Sizes**

There are six standard capacitor bank sizes utilized on distribution circuits for all voltage levels. All capacitor bank installations are three phase; no single-phase or two-phase capacitor banks are installed on the distribution system. The bank sizes are as follows:

Capacitor Bank Sizes:

- 150 kVAR
- 300 kVAR
- 450 kVAR
- 600 kVAR
- 900 kVAR
- 1200 kVAR

Any of these bank sizes can be utilized in either a fixed or switched bank configuration. In general, larger kVAR capacitor banks are switched and small kVAR capacitor banks are fixed.

Non-standard capacitor bank sizes exist on distribution circuits due to past sizing techniques and bank size availability. However, only the standard sizes mentioned above are currently being installed.





# **Electric Distribution System Planning**

## **Guidelines, Methodologies and Standards**

**Table 1**

**Tin Fuse Link**

**Continuous Current Carrying Capacity**

<b>EEI-NEMA K or T Rating</b>	<b>Continuous Current Amperes</b>
6	9
10	15
15	23
25	38
40	60 *
65	95
100	150 *
140	190
200	200 ***

\* Only when used in a 100 or 200 ampere cutout.

\*\* Only when used in a 200 ampere cutout  
(100 ampere in a 100 ampere cutout).

\*\*\* Limited by continuous current rating of cutout.

**Table 2**

**Coordination Between EEI - NEMA Type K Fuse Links**

Protecting Fuse Link Rating (Amperes)	Protected Fuse Link (Amperes)							
	10K	15K	25K	40K	65K	100K	140K	200K
6K	190	510	840	1340	2200	3900	5800	9200
10K		300	840	1340	2200	3900	5800	9200
15K			430	1340	2200	3900	5800	9200
25K				660	2200	3900	5800	9200
40K					1100	3900	5800	9200
65K						2400	5800	9200
100K							3000	9100
140K								4000

This table shows the maximum values of fault currents at which EEI-NEMA type K fuse links will coordinate with each other. The table is based on maximum clearing time curves for protecting fuses and 74 percent of minimum melting time curves for protected fuse links.

**Table 3**

**Minimum Fuse Sizes for Single-Phase Overhead and U.G. Lines**

For Cold Load Pick-Up

Lateral fuses must be sized to handle six times the normal current for one second and three times the normal current for ten seconds.

Normal current is figured at 100% connected kVA of the transformers serving gas customers and 150% of the connected kVA of the transformers serving electric heat customers. No diversity factor is used for cold load pick-up.

<b>Maximum Connected kVA (per \ )</b>				
<b>Fuse Size</b>	<b>2.4 kV</b>		<b>7.2 kV</b>	
	<b>Gas</b>		<b>Gas</b>	<b>Electric</b>
40K *	0 - 85	0 - 250	0 - 167	
65K **	0 - 135	0 - 400	0 - 250	
100K ***	136 - 200	401 - 600	251 - 400	
140K	201 - 300	601 - 900	401 - 600	

NOTE: Larger fuses may be used when coordinating with other protective devices.

2.4 kV System

- \* 40K fuses should be used only when necessary for coordination and 37.5 kVA transformers are the largest that a 40K may be used with.
- \*\* 50 kVA transformers are the largest that a 65K fuse may be used with.
- \*\*\* 75 kVA transformers are the largest that a 100K fuse may be used with.

7.2 kV System

- \* 100 kVA transformers are the largest that a 40K may be used with.

**Table 4**

**Fusing for Bay-O-Net Protected Underground Transformers**

*(12.47 kV Only)*

Transformer Size (kVA)		Kearney Fuse Amperes	RTE Fuse Amperes	Minimum Fuse Size at Lateral Amperes
1 $\phi$	3 $\phi$ *			
25	75	5	3	40K
37.5	112.5	8	8	40K
50	150	12	8	40K
75	225	15	15	65K
100	300	25	15	65K
167	500	35	25	100K
---	750	35	50	140K
---	1000	35	50	140K

Note: Larger fuses at lateral may be necessary due to total single-phase connected load.

This chart should be used where Bay-O-Net fuses are used in 3  $\phi$  underground transformers. For cases where no fuses are used, refer to fusing for 3  $\phi$  underground lateral.

**Table 5**

**Fusing for 3 $\phi$  Underground Laterals**

(Non-Bay-O-Net Fused Transformers)

<b>Laterals with only One Transformer</b>		
Largest Transformer (kVA)	Maximum Total Connected Load (kVA)	Fuse for 12.47 & 13.8 kV
150	150	15K
225	225	25K
300	300	25K
500	500	40K
750	750	65K
1000	1000	100K
1500	1500	140K
2000	2000	200K
2500	2500	200K

<b>Laterals with Multiple Transformers</b>		
Largest Transformer (kVA)	Maximum Total Connected Load (kVA)	Fuse for 12.47 and 13.8 kV
300	301 - 1500	140K
500	501 - 1500	140K
750	751 - 1500	140K
1000	1001 - 2000	200K
1500	1501 - 2000	200K

Note: 3 $\phi$  12.47kV padmount transformers up to 1000 kVA are Bay-O-Net fused. Refer to Table 4 in this appendix.

**Table 6**

<b>TRANSFORMER AND CAPACITOR FUSING</b>							
<b>Primary Fuse Sizes For 1\ Transformers</b>				<b>Primary Fuse Sizes For 3\ Transformers</b>			
Transformer Size	2,400V	7,200V	13,800V	Transformer Size	4,160V	12,470V	13,800V
Up to 15	10K	10K	10K	Up to 3 – 15	10K	10K	10K
20	15K	10K	10K	3 - 20	15K	10K	10K
25	15K	10K	10K	3 - 25	15K	10K	10K
30	25K	10K	10K	3 - 30	25K	10K	10K
37.5	25K	10K	10K	3 - 37.5	25K	10K	10K
50	40K	15K	10K	3 - 50	40K	15K	15K
75	65K <sup>1</sup>	25K	15K	3 - 75	65K <sup>1</sup>	25K	25K
100	100K <sup>2</sup>	25K	15K	3 - 100	100K <sup>2</sup>	25K	25K
<b>Capacitor Bank Fuse Sizes</b>				3 - 150		40K	40K
Size Bank (kVAR)				3 - 167		40K	40K
4 kV	12 kV	13 kV		3 - 200		65K	65K
150	25K			3 - 250		65K	65K
300	40K	15K	15K	3 - 333		100K	100K
450	65K	25K	40K	3 - 500		140K <sup>3</sup>	140K <sup>3</sup>
600	100K	40K	65K	<b>Secondary Banking</b>			
900		40K	65K	Transformer Size	Fuse Size	Circuit Breaker Size	
1200		65K	65K	3 kW - 10 kW	15K	40 amp	
1350		65K	65K	15 kW - 20 kW	25K	40 amp	
1500		100K	100K	25 kW - 30 kW	40K	70 amp	
1800		100K	100K	37.5 kW	65K	70 amp	
2100		100K	100K	50 kW	65K	100 amp	
2400			100K				

**NOTES**

- <sup>1</sup> May be reduced to 40K for coordination purposes when authorized.
- <sup>2</sup> May be reduced to 65K for coordination purposes when authorized.
- <sup>3</sup> May be reduced to 100K for coordination purposes when authorized.
- <sup>4</sup> Fuse according to smallest transformer.

Omit primary fuse on complete surge-proof transformer except when instructed. Above list does not apply to instrument transformers.



**Table 7**

<b>Power Fuses to be Used in S &amp; C Switchgear for Fusing 3<math>\phi</math> Transformers</b>			
<b>Transformer Size 3<math>\phi</math></b>	<b>12.47 kV</b>	<b>13.8 kV</b>	<b>Min. Lateral Fuse Size</b>
150 kVA	10E	10E	140K < 4300 amps fault < 200K
225 kVA	15E	15E	140K < 4300 amps fault < 200K
300 kVA	20E	20E	140K < 4300 amps fault < 200K
500 kVA	40E	30E	140K < 4300 amps fault < 200K
750 kVA	50E	50E	140K < 4300 amps fault < 200K
1000 kVA	65E	65E	140K < 3800 amps fault < 200K
1500 kVA	100E	100E	200K < 6400 amps fault < solid
2000 kVA	125E	125E	200K < 5400 amps fault < solid
2500 kVA	150E	150E	200K < 4200 amps fault < solid
<b>Power Fuses to be Used in S &amp; C Switchgear for Fusing 1<math>\phi</math> Loads</b>			
0 - 100 kVA	20E	20E	140K < 4300 amps fault < 200K
101 - 150 kVA	30E	30E	140K < 4300 amps fault < 200K
151 - 200 kVA	40E	40E	140K < 4300 amps fault < 200K
201 - 250 kVA	50E	50E	140K < 4300 amps fault < 200K
251 - 350 kVA	65E	65E	140K < 3800 amps fault < 200K
351 - 400 kVA	80E	80E	140K < 3500 amps fault < 200K
401 - 500 kVA	100E	100E	140K < 6400 amps fault < solid
501 - 700 kVA	125E	125E	140K < 5400 amps fault < solid
<b><u>LEGEND</u></b>			
Use 200K fuses if 1 $\phi$ fault at switchgear is less than 5400 amps			
200K < 500 amps fault < solid			
Use solid blades if 1 $\phi$ fault at switchgear is greater than 5400 amps.			

**Table 8**

**Power Transformer Loading and Loss of Life**

These guidelines are based solely on the insulation deterioration of the transformer windings. Other items such as oil expansion space, ratings of bushings, tap changers and leads should be considered before overloading a given transformer. These guidelines should only be used for transformers rated below 100 MVA. Stray flux heating becomes a problem in transformers greater than 100 MVA and the risk of failure is much greater.

Most manufacturers and utility engineers now recommend a winding hot spot limit of 140°C. This is being studied and some engineers believe that this will be increased in the future. The following limits were used to establish this guideline:

**TRANSFORMER TEMPERATURE LIMITS (65°C RATED)**

110°C Top Oil, 140°C Hot Spot

**Loss of Life Limits**

Duration of Emergency	Loss of Life Allowance
6 months      (130 load days)	15.0 %
1 month        (22 load days)	10.0 %
1 week         (5 load days)	3.5 %

The Winding hot spot of 140°C is usually the first limit reached. If this limit was increased to 150°C, most of the loadings could be increased. The hot-spot limit was established to prevent the formation of gas bubbles in the insulation system. Gas bubbles result in temporary reduction of the dielectric strength. This could result in instantaneous failure if a transient overvoltage occurs while the insulation is in this weakened state, or perhaps even at normal operating voltages.

**Table 8** (cont.)

Using the above limits, the following table should be used as a guideline:

<b>Allowable Summer (98°F Day) and Winter (50°F Day) Loading In Per Unit of 65°C Top Rating</b>				
<b>Duration of Emergency</b>	<b>Summer Load</b>	<b>Limiting Factor</b>	<b>Winter Load</b>	<b>Limiting Factor</b>
0 (Normal)	1.07	Loss of Life	1.26	Loss of Life
15 minutes	1.35	Hot Spot	1.66	Hot Spot
30 minutes	1.29	Hot Spot	1.55	Hot Spot
1 hour	1.25	Hot Spot	1.47	Hot Spot
2 hours	1.20	Hot Spot	1.40	Hot Spot
10 hours	1.19	Hot Spot	1.37	Hot Spot
1 day	1.19	Hot Spot	1.36	Hot Spot
1 week	1.19	Hot Spot	1.36	Hot Spot
1 month	1.19	Hot Spot	1.36	Hot Spot
6 months	1.15	Loss of Life	1.34	Loss of Life

This guideline should be used for planning purposes. Specific transformers can be analyzed on a case by case basis with more accurate specifications and possibly real-time load and temperature data.

The loading could be increased somewhere between 6% to 9% on duration's of one month or less if the winding hot spot limit were increased to 150°C. The risk of bubble formation is much greater at 150°C and depends greatly on the moisture content of the winding insulation. The following loads could be used for summer loading if the hot spot limit increased to 150°C.

**Table 8** (cont.)

<b>Possible Summer Loading with Hot Spot Limit of 150°C (Risk of Bubble Formation if Hot Spot is Limiting Factor)</b>		
<b>Duration of Emergency</b>	<b>Summer Load</b>	<b>Limiting Factor</b>
0 (Normal)	1.07	Loss of Life
15 minutes	1.47	Hot Spot (150°C)
30 minutes	1.40	Hot Spot (150°C)
1 hour	1.33	Hot Spot (150°C)
2 hours	1.28	Hot Spot (150°C)
10 hours	1.26	Hot Spot (150°C)
1 day	1.26	Hot Spot (150°C)
1 week	1.26	Hot Spot (150°C)
1 month	1.26	Hot Spot (150°C)
6 months	1.15	Loss of Life

In the computer runs used to establish the guideline:

- Typical transformer characteristics were used.
- A normalized 1993 system 24-hour load curve was used.
- A typical ambient 24-hour temperature curve was assumed.
- 1% average moisture content in the insulation was assumed.
- Bubble formations were tested at 0.64% and 1.5% moisture content at the hot spot.
- A transformer with a 26.9/32/44.8 MVA OA/FA/FA (65°C average winding rise) rating was simulated.
- A nitrogen gas blanket at 999mm Hg pressure for oil preservation was used.
- A 48-inch static head of oil above hot spot was simulated.
- All overloads greater than 2 hours were assumed to have a daily load cycle with a step increase to a similar load cycle for the length of the overload and then return to the daily load cycle.
- Overloads of two hours and less were assumed to increase to a constant load for the length of the overload and then return to the daily load cycle.
- A daily load cycle with a magnitude of 1.0 per unit was used to establish the preload state of the transformer.

**Table 9**

**Fuse and Recloser Coordination**

			FUSE SIZE									
			200K		140K		100K		65K		40K	
<b>RECLOSER SIZE</b>	<b>50</b>	<b>Min</b>							800	300	180	140
		<b>H</b>	<b>Max</b>						1250	1250	1100	800
	<b>50</b>	<b>Min</b>			2400	1400	1100	600	3300	250	160	140
		<b>L</b>	<b>Max</b>			3000	3000	3000	2500	1700	1400	980
	<b>70</b>	<b>Min</b>			2000	1100	850	470	280	230	0	0
		<b>L</b>	<b>Max</b>			4000	4000	2900	2400	1600	1300	900
	<b>100</b>	<b>Min</b>	3400	1900	1500	700	500	400	0	0	0	0
		<b>L</b>	<b>Max</b>	6000	6000	4600	3700	2700	2100	1500	1200	780
	<b>140</b>	<b>Min</b>	2700	1600	800	580	420	350	0	0		
		<b>L</b>	<b>Max</b>	6000	6000	4500	3600	2500	2000	1300	1000	
	<b>200</b>	<b>Min</b>	1900	1200	600	510	0	0	0	0		
		<b>L</b>	<b>Max</b>	6000	5600	4000	3200	2500	1700	1100	700	
	<b>280</b>	<b>Min</b>	1400	1100	0	0	0	0				
		<b>L</b>	<b>Max</b>	6000	5200	4000	3100	2200	1500			
	<b>225</b>	<b>Min</b>	1500	1100	500	475	0	0	0	0		
		<b>D</b>	<b>Max</b>	5800	4600	3600	3000	2100	1650	1100	800	
	<b>280</b>	<b>Min</b>	1300	1050	0	0	0	0	0	0		
		<b>D</b>	<b>Max</b>	5800	4700	3600	2900	2000	1550	1000	680	
<b>400</b>	<b>Min</b>	1050	850	0	0	0	0					
	<b>D</b>	<b>Max</b>	5800	4600	3500	2700	1700	1200				

**Table 10**

<b>ENGINEERING PRACTICES - ELECTRIC DISTRIBUTION</b>			
<b>POWER FUSES TO BE USED IN S &amp; C SWITCHGEAR FOR FUSING 3<math>\phi</math> TRANSFORMERS</b>			
<b>Transformer</b>	<b>12.47KV</b>	<b>13.8KV</b>	<b>Min. Lateral Fuse Size</b>
150 KVA	10 E	10 E	140 K < 4300 amps fault < 200 K
225 KVA	15 E	15 E	140 K < 4300 amps fault < 200 K
300 KVA	20 E	20 E	140 K < 4300 amps fault < 200 K
500 KVA	40 E	30 E	140 K < 4300 amps fault < 200 K
750 KVA	50 E	50 E	140 K < 4300 amps fault < 200 K
1000 KVA	65 E	65 E	140 K < 3800 amps fault < 200 K
1500 KVA	100 E	100 E	200 K < 6400 amps fault < solid
2000 KVA	125 E	125 E	200 K < 5400 amps fault < solid
2500 KVA	150 E	150 E	200 K < 4200 amps fault < solid
<b>POWER FUSES TO BE USED IN S &amp; C SWITCHGEAR FOR FUSING 1<math>\phi</math> LOADS</b>			
0 - 100 KVA	20 E		140 K < 4300 amps fault < 200 K
101 - 150	30 E		140 K < 4300 amps fault < 200 K
151 - 200	40 E		140 K < 4300 amps fault < 200 K
201 - 250	50 E		140 K < 4300 amps fault < 200 K
251 - 350	65 E		140 K < 3800 amps fault < 200 K
351 - 400	80 E		140 K < 3500 amps fault < 200 K
401 - 500	100 E		140 K < 6400 amps fault < solid
501 - 700	125 E		140 K < 5400 amps fault < solid
<b><u>LEGEND</u></b>			
Use 200 K fuses if 1 $\phi$ fault at switchgear is less than 5400 amps			
200 K < 500 amps fault < solid			
Use solid blades if 1 $\phi$ fault at switchgear is greater than 5400 amps.			
Prepared by: DRB		Approved by: CDT	
Date: 04-06-76		Date: 04-14-76	
		L.G.&E.	

**LOUISVILLE GAS AND ELECTRIC COMPANY**

**Response to Commission Staff's Fifth Request for Information  
Dated March 19, 2021**

**Case No. 2020-00350**

**Question No. 18**

**Responding Witness: John K. Wolfe**

- Q-18. Refer to the Seelye Testimony in general. Provide KU/LG&E's distribution system planning criteria used for determining whether equipment requires replacement for thermal violations.
- A-18. System Planning uses the following criteria for recommending equipment replacement or capacity increases:
- Transformer replacement/increase at 100% of nameplate rating in Summer or 120% of nameplate rating in Winter based on forecasted loading
  - Conductor replacement at 100% of thermal rated capacity for season

**LOUISVILLE GAS AND ELECTRIC COMPANY**

**Response to Commission Staff's Fifth Request for Information  
Dated March 19, 2021**

**Case No. 2020-00350**

**Question No. 19**

**Responding Witness: John K. Wolfe**

- Q-19. Refer to the Seelye Testimony in general. For the most recent three years available, provide KU/LG&E's 8,760 hours of load at each distribution substation for each year. Provide the response in Excel format with all formulas, columns, and rows unprotected and fully accessible. If 8,760 load profiles are not available, provide each substation's peak hour for each year.
- A-19. See attachment being provided in Excel format.



The attachment is being provided in a separate file in Excel format.

**LOUISVILLE GAS AND ELECTRIC COMPANY**

**Response to Commission Staff's Fifth Request for Information  
Dated March 19, 2021**

**Case No. 2020-00350**

**Question No. 20**

**Responding Witness: William Steven Seelye**

- Q-20. Reference KU/LG&E's response to Strategen question Item 4. State whether either KU or LG&E has conducted any empirical analysis using its own or proxy data to evaluate the distributed energy resource generation, transmission, and distribution avoided capacity values using LOLP, LOLE, LOLH, or EUE. If yes, provide all documents related to the analysis in Excel format with all formulas, columns, and rows unprotected and fully accessible, where applicable.
- A-20. LOLP, LOLE, LOLH, and EUE are not measurements used for transmission and distribution planning. LOLP, LOLE, LOLH, and EUE modelling only have relevance regarding generation capacity planning. Transmission planning is performed in accordance with locational fault analysis as prescribed in NERC TPL-001 and MOD-032. Distribution asset planning also utilizes locational fault analysis and non-coincidental loads on substation, circuits and line transformers for distribution capacity planning. Transmission and distribution planning are largely based on the location of load increases and the analysis of potential faults on the systems. Transmission and distribution planning are not modelled with LOLP, LOLE, LOLH, or EUE.

The Companies are currently studying whether a Distributed Energy Management System (DERMS) will be needed to address problems created by distributed energy resources (DERs). DERs are more likely than not to create issues on the distribution system which will result in increased costs.

The Companies performed a Loss of Load Probability (LOLP) and Expected Unserved Energy (EUE) analysis with and without the hourly energy (evaluated as capacity in these analyses) that the Companies' DERs supply to the grid. The analysis indicates that the hourly energy supplied to the grid has no material impact on LOLP or EUE. The results of the hourly analysis of the LOLP and EUE are included in the attached spreadsheet. The analysis was performed using the PROSYM production cost model. The PROSYM model and the input data used in the model are described in the responses to AG-KIUC 1-121 and AG-KIUC 1-122. Also, see Section 16(7)(c) – Item G, at Tab 16 of the Filing Requirements.

The attachment is being provided in a separate file in Excel format.

**LOUISVILLE GAS AND ELECTRIC COMPANY**

**Response to Commission Staff's Fifth Request for Information  
Dated March 19, 2021**

**Case No. 2020-00350**

**Question No. 21**

**Responding Witness: William Steven Seelye**

- Q-21. Provide time-differentiated, or marginal, transmission and distribution loss factors and all underlying workpapers for KU/LG&E. Provide workpapers in Excel format with all formulas, columns, and rows unprotected and fully accessible.
- A-21. The energy and demand loss factors by voltage level were provided in the response to AG-KIUC 1-141. The loss study used to derive the loss factors is attached. See Table 1.

**LG&E AND KU SERVICES COMPANY**

**LG&E Power System  
2010 Analysis of System Losses**

**August 2012**

Prepared by:



Management Applications Consulting, Inc.  
1103 Rocky Drive – Suite 201  
Reading, PA 19609  
Phone: (610) 670-9199 / Fax: (610) 670-9190



## MANAGEMENT APPLICATIONS CONSULTING, INC.

---

1103 Rocky Drive • Suite 201 • Reading, PA 19609-1157 • 610/670-9199 • fax 610/670-9190 • www.manapp.com

August 16, 2012

Mr. Robert M. Conroy  
Director of Rates  
LG&E and KU Services Company  
220 West Main Street  
Louisville, KY 40202

**RE: 2010 LOSS ANALYSIS – LG&E**

Dear Mr. Conroy:

Transmitted herewith are the results of the 2010 Analysis of System Losses for LG&E and KU Services Company's Louisville Gas & Electric (LG&E) power system. Our analysis develops cumulative expansion factors (loss factors) for both demand (peak/kW) and energy (average/kWh) losses by discrete voltage levels applicable to metered sales data. Our analysis considers only technical losses in arriving at our final recommendations. Please note that the proposed loss factors include a common or system-wide transmission factor for both LG&E and KU studies.

On behalf of MAC, we appreciate the opportunity to assist you in performing the loss analysis contained herein. The level of detailed load research and sales data by voltage level, coupled with a summary of power flow data and power system model, forms the foundation for determining reasonable and representative power losses on the LG&E system. Our review of these data and calculated loss results support the proposed loss factors as presented herein for your use in various cost of service, rate studies, and demand analyses.

Should you require any additional information, please let us know at your earliest convenience.

Sincerely,

A handwritten signature in cursive script that reads "Paul M. Normand".

Paul M. Normand  
Principal

Enclosure  
PMN/rjp

**LG&E AND KU SERVICES COMPANY**  
**2010 Analysis of System Losses – LG&E Power System**

---

**TABLE OF CONTENTS**

<b>1.0 EXECUTIVE SUMMARY .....</b>	<b>1</b>
<b>2.0 INTRODUCTION.....</b>	<b>6</b>
<b>2.1 Conduct of Study.....</b>	<b>6</b>
<b>2.2 Description of Model.....</b>	<b>7</b>
<b>2.2 Description of Model.....</b>	<b>7</b>
<b>3.0 METHODOLOGY .....</b>	<b>9</b>
<b>3.1 Background .....</b>	<b>9</b>
<b>3.2 Analysis and Calculations .....</b>	<b>11</b>
<b>3.2.1 Bulk, Transmission and Subtransmission Lines .....</b>	<b>11</b>
<b>3.2.2 Transformers.....</b>	<b>12</b>
<b>3.2.3 Distribution System .....</b>	<b>12</b>
<b>4.0 DISCUSSION OF RESULTS .....</b>	<b>14</b>

Appendix A – Results of LG&E (LG&E and KU) Transmission System 2010 Loss Analysis

Appendix B – Results of LG&E 2010 Loss Analysis

Appendix C – Discussion of Hoebel Coefficient



**LG&E AND KU SERVICES COMPANY**  
**2010 Analysis of System Losses – LG&E Power System**

---

**1.0 EXECUTIVE SUMMARY**

This report presents LG&E 2010 Analysis of System Losses for the power systems as performed by Management Applications Consulting, Inc. (MAC). The study developed separate demand (kW) and energy (kWh) loss factors for each voltage level of service in the power system for LG&E. The cumulative loss factor results by voltage level, as presented herein, can be used to adjust metered kW and kWh sales data for losses in performing cost of service studies, determining voltage discounts, and other analyses which may require a loss adjustment.

The procedures used in the overall loss study were similar to prior studies and emphasized the use of "in house" resources where possible. To this end, extensive use was made of the Company's peak hour power flow data and transformer plant investments in the model. In addition, measured and estimated load data provided a means of calculating reasonable estimates of losses by using a "top-down" and "bottom-up" procedure. In the "top-down" approach, losses from the high voltage system, through and including distribution substations, were calculated along with power flow data, conductor and transformer loss estimates, and metered poles.

At this point in the analysis, system loads and losses at the input into the distribution substation system are known with reasonable accuracy. However, it is the remaining loads and losses on the distribution substations, primary system, secondary circuits, and services which are generally difficult to estimate. Estimated and actual Company load data provided the starting point for performing a "bottom-up" approach for calculating the remaining distribution losses. Basically, this "bottom-up" approach develops line loadings by first determining loads and losses at each level beginning at a customer's meter service entrance and then going through secondary lines, line transformers, primary lines, and finally distribution substation. These distribution system loads and associated losses are then compared to the initial calculated input into Distribution Substation loadings for reasonableness prior to finalizing the loss factors. An overview of the loss study is shown on Figure 1 on page 4.

Appendix A of this report presents the Transmission loss analysis which was calculated separately and the results incorporated into the final loss factors as shown on Table 1 on the next page.

Table 1 (columns (a) and (b)) also provides the final results from Appendix B for the 2010 calendar year. Exhibits 8 and 9 of Appendix B present a more detailed analysis of the final calculated summary results of losses by segments and delivery voltage of the power system. The following Table 1 cumulative loss expansion factors are applicable only to metered sales at the point of receipt for adjustment to the power system's input level.





**LG&E AND KU SERVICES COMPANY**  
**2010 Analysis of System Losses – LG&E Power System**

**TABLE 1**  
**Loss Factors at Sales (Meter) Level, Calendar Year 2010**

<u>Voltage Level of Service</u>	<u>Total LG&amp;E</u> (a)	<u>Delivery System (Excludes Transmission)</u> (b)	<u>Recalculated Total LG&amp;E With Appendix A Transmission Losses</u>	
			(c)	(d) = 1/(c)
<u>Demand (kW)</u>				
Transmission <sup>1</sup>	1.01549	1.00000	1.02805	0.97272
Primary Substation	1.02152	1.00594	1.03415	0.96698
Primary	1.04295	1.02704	1.05585	0.94710
Secondary	1.06325	1.04703	1.07640	0.92902
<u>Energy (kWh)</u>				
Transmission <sup>1</sup>	1.01033	1.00000	1.02271	0.97779
Primary Substation	1.01619	1.00581	1.02865	0.97215
Primary	1.02998	1.01946	1.04261	0.95913
Secondary	1.05325	1.04160	1.06525	0.93875
Losses – Net System Input <sup>2</sup>	4.37% MWh			
	5.56% MW			
Losses – Net System Output <sup>3</sup>	4.57% MWh			
	5.89% MW			

*Notes: Column (a) Results derived from Appendix A for Transmission and Appendix B for all remaining factors.*

*Column (b) Column (a) loss factors excluding all Transmission-related losses.*

*Column (c) Column (b) delivery-only loss factors with incorporating the composite LG&E system-wide Transmission loss factors from Appendix A, Schedule 1, lines 5 and 10.*

*Column (d) All loss factors presented in columns (a), (b), and (c) are expansion factors applicable to metered sales as a multiplier. Column (d) is simply the inverse of column (c) and results in a loss factor that is used to divide metered sales to derive sales requirement at input.*

The loss factors presented in the Delivery Only column of Table 1 are the Total LG&E loss factors divided by the transmission loss factor from column (a) in order to remove these losses from each service level loss factor. For example, the secondary distribution demand loss factor of 1.04703 includes the recovery of all remaining non-transmission losses from the distribution substation, primary lines, line transformers, secondary conductors and services.

<sup>1</sup> Reflects results for 500 kV, 345 kV, 161 kV, 138 kV and 69 kV from Appendix A.

<sup>2</sup> Net system input equals firm sales plus losses. Company use less non-requirement sales and related losses. See Appendix A, Exhibit 1, for their calculations.

<sup>3</sup> Net system output uses losses divided by output or sales data as a reference.

**LG&E AND KU SERVICES COMPANY**  
**2010 Analysis of System Losses – LG&E Power System**

---

The net system input shown in Table 1 represents the MWh losses of 4.37% for the total LG&E load using calculated losses divided by the associated input energy to the system. The 5.56% represents the MW losses also using system input as a reference. The net system output reference shown in Table 1 represents MWh losses of 4.57% and MW losses of 5.89%. These results use the appropriate total losses for each but are divided by system output or sales. These calculations are all based on the data and results shown on Exhibits 1, 7 and 9 of the study.

Due to the very nature of losses being primarily a function of equipment loadings, the loss factor derivations for any voltage level must consider both the load at that level plus the loads from lower voltages and their associated losses. As a result, cumulative losses on losses equates to additional load at higher levels along with future changes (+ or –) in loads throughout the power system. It is therefore important to recognize that losses are multiplicative in nature (future) and not additive (test year only) for all future years to ensure total recovery based on prospective fixed loss factors for each service voltage.

The derivation of the cumulative loss factors (Appendix B) shown in Table 1 (columns (a) and (b)) have been detailed for all electrical facilities in Exhibit 9, page 1 for demand and page 2 for energy. Beginning on line 1 of page 1 (demand) under the secondary column, metered sales are adjusted for service losses on lines 3 and 4. This new total load (with losses) becomes the load amount for the next higher facilities of secondary conductors and their loss calculations. This process is repeated for all the installed facilities until the secondary sales are at the input level (line 45). The final loss factor for all delivery voltages using this same process is shown on line 46 and Table 1 for demand. This procedure is repeated in Exhibit 9, page 2, for the energy loss factors.

The loss factor calculation is simply the input required (line 45) divided by the metered sales (line 2).

An overview of the loss study is shown on Figure 1 on the next page. Figure 2 simply illustrates the major components that must be considered in a loss analysis.



**LG&E AND KU SERVICES COMPANY  
 2010 Analysis of System Losses – LG&E Power System**

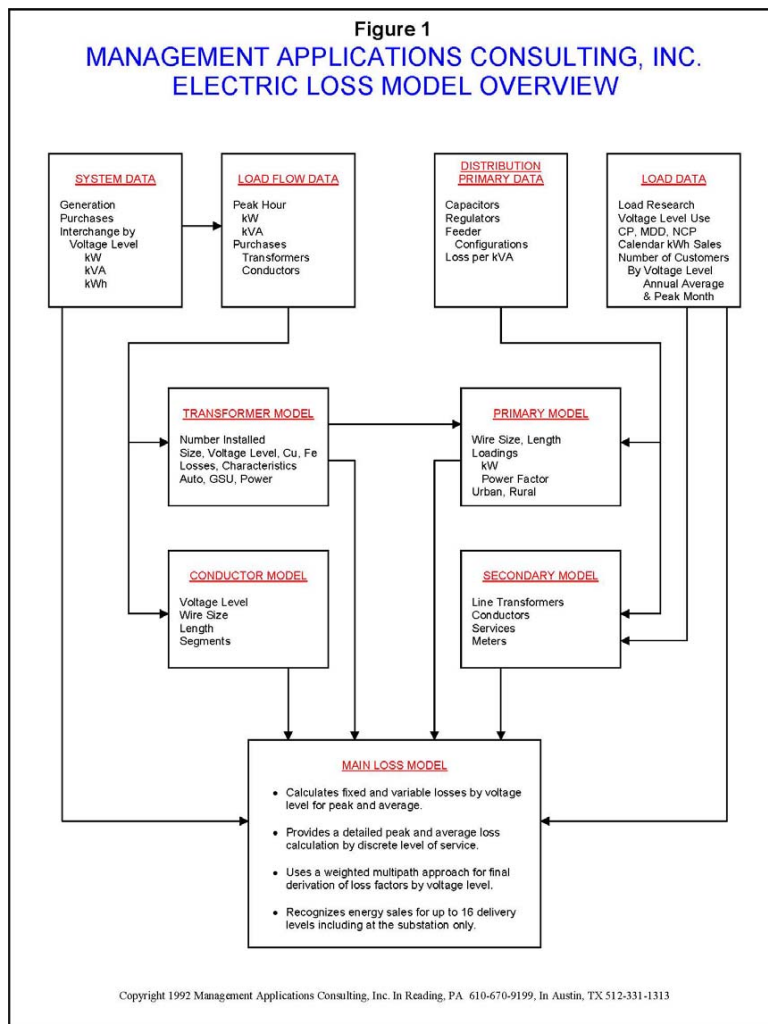

**LG&E AND KU SERVICES COMPANY**  
**2010 Analysis of System Losses – LG&E Power System**

---

Figure 2  
**LG&E and KU Services Company – LG&E**  
**Jurisdiction Energy and Loss Components**

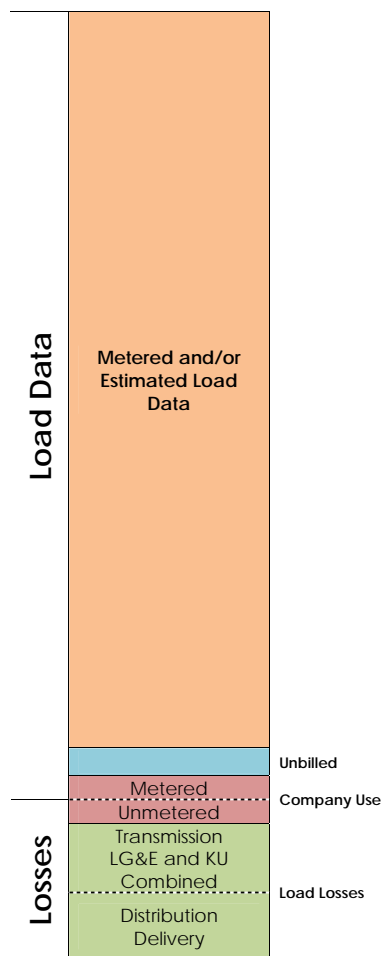

**LG&E AND KU SERVICES COMPANY**  
**2010 Analysis of System Losses – LG&E Power System**

---

**2.0 INTRODUCTION**

This report of the 2010 Analysis of System Losses for the LG&E power system provides a summary of results, conceptual background or methodology, description of the analyses, and input information related to the study.

**2.1 Conduct of Study**

Typically, between five to ten percent of the total kWh requirements of an electric utility is lost or unaccounted for in the delivery of power to customers. Investments must be made in facilities which support the total load which includes losses or unaccounted for load. Revenue requirements associated with load losses are an important concern to utilities and regulators in that customers must equitably share in all of these cost responsibilities. Loss expansion factors are the mechanism by which customers' metered demand and energy data are mathematically adjusted to the generation or input level (point of reference) when performing cost and revenue calculations.

An acceptable accounting of losses can be determined for any given time period using available engineering, system, and customer data along with empirical relationships. This loss analysis for the delivery of demand and energy utilizes such an approach. A microcomputer loss model<sup>4</sup> is utilized as the vehicle to organize the available data, develop the relationships, calculate the losses, and provide an efficient and timely avenue for future updates and sensitivity analyses. Our procedures and calculations are similar with prior loss studies, and they rely on numerous databases that include customer statistics and power system investments.

Company personnel performed most of the data gathering and data processing efforts and checked for reasonableness. MAC provided assistance as necessary to construct databases, transfer files, perform calculations, and check the reasonableness of results. A review of the preliminary results provided for additions to the database and modifications to certain initial assumptions based on available data. Efforts in determining the data required to perform the loss analysis centered on information which was available from existing studies or reports within the Company. From an overall perspective, our efforts concentrated on five major areas:

1. System information concerning peak demand and annual energy requirements by voltage level,
2. High voltage power system power flow data and associated loss calculations,
3. Distribution system primary and secondary loss calculations,
4. Derivation of fixed and variable losses by voltage level, and
5. Development of final cumulative expansion factors at each voltage for peak demand (kW) and annual energy (kWh) requirements at the point of delivery (meter).

---

<sup>4</sup>Copyright by Management Applications Consulting, Inc.



**LG&E AND KU SERVICES COMPANY**  
**2010 Analysis of System Losses – LG&E Power System**

---

**2.2 Electric Power Losses**

Losses in power systems consist of primarily technical losses with a much smaller level of non-technical losses.

Technical Losses

Electrical losses result from the transmission of energy over various electrical equipment. The largest component of these losses is power dissipation as a result of varying loading conditions and are oftentimes called load losses which are proportional to the square of the current ( $I^2R$ ). These losses can be as high as 75% of all technical losses. The remaining losses are called no-load and represent essentially fixed (constant) energy losses throughout the year. These no-load losses represent energy required by a power system to energize various electrical equipment regardless of their loading levels. The major portion of no-load losses consists of core or magnetizing energy related to installed transformers throughout the power system.

Non-Technical Losses

These are unaccounted for energy losses that are related to energy theft, metering, non-payment by customers, and accounting errors. Losses related to these areas are generally very small and can be extremely difficult and subjective to quantify. Our efforts generally do not develop any meaningful level as appropriate because we assume that improving technology and utility practices have minimized these amounts.

**2.3 Description of Model**

The loss model is a customized applications model, constructed using the Excel software program. Documentation consists primarily of the model equations at each cell location. A significant advantage of such a model is that the actual formulas and their corresponding computed values at each cell of the model are immediately available to the analyst.

A brief description of the three (3) major categories of effort for the preparation of each loss model is as follows:

- Main sheet which contains calculations for all primary and secondary losses, summaries of all conductor and transformer calculations from other sheets discussed below, output reports and supporting results.



**LG&E AND KU SERVICES COMPANY**  
**2010 Analysis of System Losses – LG&E Power System**

---

- Transformer sheet which contains data input and loss calculations for each distribution substation. Separate iron and copper losses are calculated for each transformer by identified type.

Appendix A presents a separate hourly loss study result which derived the loss factors for the combined LG&E system-wide Transmission only (69 kV through 500 kV) of the LG&E and KU power system. These Transmission results are then incorporated on Table 1 of the Executive summary to derive the final LG&E 2010 loss factors by voltage level of energy delivery.

Appendix B presents a detailed loss study result which derives the loss factors for the Company's system-wide power system. Appendix B, Exhibits 8 and 9, presents the final detailed summary results of the demand and energy losses for each major portion of the total LG&E power system.

**LG&E AND KU SERVICES COMPANY**  
**2010 Analysis of System Losses – LG&E Power System**

---

**3.0 METHODOLOGY**

**3.1 Background**

The objective of a Loss Study is to provide a reasonable set of energy (average) and demand (peak) loss expansion factors which account for system losses associated with the transmission and delivery of power to each voltage level over a designated period of time. The focus of this study is to identify the difference between total energy inputs and the associated sales with the difference being equitably allocated to all delivery levels. Several key elements are important in establishing the methodology for calculating and reporting the Company's losses. These elements are:

- Selection of voltage level of services,
- Recognition of losses associated with conductors, transformations, and other electrical equipment/components within voltage levels,
- Identification of customers and loads at various voltage levels of service,
- Review of generation or net power supply input at each level for the test period studied, and
- Analysis of kW and kWh sales by voltage levels within the test period.

The three major areas of data gathering and calculations in the loss analysis were as follows:

1. System Information (monthly and annual)
  - MWH generation and MWH sales.
  - Coincident peak estimates and net power supply input from all sources and voltage levels.
  - Customer load data estimates from available load research information, adjusted MWH sales, and number of customers in the customer groupings and voltage levels identified in the model.
  - System default values, such as power factor, loading factors, and load factors by voltage level.





**LG&E AND KU SERVICES COMPANY**  
**2010 Analysis of System Losses – LG&E Power System**

---

2. High Voltage System (Appendix A)
  - Conductor information was summarized from a database by the Company which reflects the transmission system by voltage level. Extensive use was made of the Company's power flow data with the losses calculated and incorporated into the final loss calculations.
  - Transformer information was developed in a database to model transformation at each voltage level. Substation power, step-up, and auto transformers were individually identified along with any operating data related to loads and losses.
  - Power flow data and calculations for each hour (8760) formed the basis for the peak and annual load losses in the high voltage (500 kV through 69 kV) loss calculations.
  
3. Distribution System (Appendix B)
  - Distribution Substations – Data was developed for modeling each substation as to its size and loading. The Company provided loss characteristics for each transformer. Loss calculations were performed from this data to determine no load losses separately for each transformer. The annual load losses were calculated using an average load level for each transformer which replaced the prior Hoebel formula method.
  - Primary lines – Line loading and loss characteristics for several representative primary circuits were obtained from the Company. These loss results developed kW loss per MW of load and a composite average percentage was calculated to derive the primary loss estimate.
  - Line transformers – Losses in line transformers were based on each customer service group's size, as well as the number of customers per transformer. Accounting and load data provided the foundation with which to model the transformer loadings and to calculate load and no load losses.
  - Secondary network – Typical secondary networks were estimated for conductor sizes, lengths, loadings, and customer penetration for residential and small general service customers.
  - Services – Typical services were estimated for each secondary service class of customers identified in the study with respect to type, length, and loading.



**LG&E AND KU SERVICES COMPANY**  
**2010 Analysis of System Losses – LG&E Power System**

---

The loss analysis was thus performed by constructing the model in segments and subsequently calculating the composite until the constraints of peak demand and energy were met:

- Information as to the physical characteristics and loading of each transformer and conductor segment was modeled.
- Conductors, transformers, and distribution were grouped by voltage level, and unadjusted losses were calculated.
- The loss factors calculated at each voltage level were determined by "compounding" the per-unit losses. Equivalent sales at the supply point were obtained by dividing sales at a specific level by the compounded loss factor to determine losses by voltage level.
- The resulting demand and energy loss expansion factors were then used to adjust all sales to the generation or input level in order to estimate the difference.
- Reconciliation of kW and kWh sales by voltage level using the reported system kW and kWh was accomplished by adjusting the initial loss factor estimates until the mismatch or difference was eliminated (Appendix B, Exhibits 6 and 7).

**3.2 Calculations and Analysis**

This section provides a discussion of the input data, assumptions, and calculations performed in the loss analysis. Specific appendices have been included in order to provide documentation of the input data utilized in the model.

**3.2.1 Bulk and Transmission Lines (500 kV – 69 kV)**

The transmission line losses were calculated based on a modeling of unique voltage levels identified by the Company's power flow data and configuration for the entire integrated Power System (Appendix A). Specific information as to length of line, type of conductor, voltage level, and hourly loading were utilized as data input in the power flow analyses.

Actual MW and MVA line loadings were based on LG&E's hourly loading conditions. Calculations of line losses were performed and summarized by fixed and variable components for both Transmission and GSU facilities for reporting purposes as shown in Appendix A of this report.



**LG&E AND KU SERVICES COMPANY**  
**2010 Analysis of System Losses – LG&E Power System**

---

**3.2.2 Bulk and Transmission Transformers**

The transmission transformer loss analysis required several steps in order to properly consider the characteristics associated with various transformer types; such as, step-up, auto transformers, distribution substations, and line transformers. In addition, further efforts were required to identify both iron and copper losses within each of these transformer types in order to obtain reasonable peak (kW) and average annual energy (kWh) losses. While iron losses were considered essentially constant for each hour, recognition had to be made for the varying degree of copper losses due to hourly equipment loadings.

The remaining miscellaneous losses considered in the loss study consisted of several areas which do not lend themselves to any reasonable level of modeling for estimating their respective losses and were therefore lumped together into a single loss factor of 0.10%. The typical range of values for these losses is from 0.10% to 0.25%, and we have assumed the lower value to be conservative at this time. The losses associated with this loss factor include bus bars, un-metered station use, and grounding transformers.

**3.2.3 Distribution System**

The load data at the substation and customer level, coupled with primary and secondary network information, was sufficient to model the distribution system in adequate detail to calculate losses.

Distribution Substations

The Distribution Substation loss derivation required several steps to recognize the loss characteristics relating to iron or fixed losses versus the copper or load varying ( $I^2R$ ) losses. The fixed component was based on Company loss characteristics from manufacturer's test results. The annual variable loss calculations considered a different approach by using an average hourly loading level and used this to the peak hour losses as a ratio  $(\text{average/peak})^2$  times 8760 hours with an average adjustment factor and peak hour losses.

Primary Lines

Primary line loadings take into consideration the available distribution load along with the actual customer loads including losses. Primary line loss estimates were prepared by the Company for use in this loss study. These estimates considered loads per substation, voltage levels, loadings, total circuit miles, wire size, and single- to three-phase investment estimates. All of these factors were considered in calculating the actual demand (kW) and energy (kWh) for the primary system.



**LG&E AND KU SERVICES COMPANY**  
**2010 Analysis of System Losses – LG&E Power System**

---

Line Transformers

Losses in line transformers were determined based on typical transformer sizes for each secondary customer service group and an estimated or calculated number of customers per transformer. Accounting records and estimates of load data provided the necessary database with which to model the loadings. These calculations also made it possible to determine separate copper and iron losses for distribution line transformers, based on a table of representative losses for various transformer sizes.

Secondary Line Circuits

A calculation of secondary line circuit losses was performed for loads served through these secondary line investments. Estimates of typical conductor sizes, lengths, loadings and customer class penetrations were made to obtain total circuit miles and losses for the secondary network. Customer loads which do not have secondary line requirements were also identified so that a reasonable estimate of losses and circuit miles of these investments could be made.

Service Drops and Meters

Service drops were estimated for each secondary customer reflecting conductor size, length and loadings to obtain demand losses. A separate calculation was also performed using customer maximum demands to obtain kWh losses. Meter loss estimates were also made for each customer and incorporated into the calculations of kW and kWh losses included in the Summary Results.

**LG&E AND KU SERVICES COMPANY**  
**2010 Analysis of System Losses – LG&E Power System**

---

**4.0 DISCUSSION OF RESULTS**

A brief description of each Exhibit is provided in Appendices A and B:

Exhibit 1 – Summary of Company Data

This exhibit reflects system information used to determine percent losses and a detailed summary of kW and kWh losses by voltage level. The loss factors developed in Exhibit 7 are also summarized by voltage level.

Exhibit 2 – Summary of Conductor Information

A summary of MW and MWH load and no load losses for Distribution conductors by voltage levels is presented. The sum of all calculated losses by high voltage is based on input data information provided in Appendix A. Percent losses are based on equipment loadings.

Exhibit 3 – Summary of Transformer Information

This exhibit summarizes Distribution transformer losses by various types and voltage levels throughout the system. Load losses reflect the copper portion of transformer losses while iron losses reflect the no load or constant losses. MWH losses are estimated using an average load loss factor for copper and the annual load losses times the test year hours.

Exhibit 4 – Summary of Losses Diagram (2 Pages)

This loss diagram represents the inputs and output of power at system peak conditions. Page 1 details information from all points of the power system and what is provided to the distribution system for primary loads. This portion of the summary can be viewed as a "top down" summary into the distribution system.

Page 2 represents a summary of the development of primary line loads and distribution substations based on a "bottom up" approach. Basically, loadings are developed from the customer meter through the Company's physical investments based on load research and other metered information by voltage level to arrive at MW and MVA requirements during peak load conditions by voltage levels.

Exhibit 5 – Summary of Sales and Calculated Losses

Summary of Calculated Losses represents a tabular summary of MW and MWH load and no load losses by discrete areas of delivery within each voltage level. Losses have been identified and are derived based on summaries obtained from Exhibits 2 and 3 and losses associated with meters, capacitors and regulators.



**LG&E AND KU SERVICES COMPANY**  
**2010 Analysis of System Losses – LG&E Power System**

---

Exhibit 6 – Development of Loss Factors, Unadjusted

This exhibit calculates demand and energy losses and loss factors by specific voltage levels based on sales level requirements. The actual results reflect loads by level and summary totals of losses at that level, or up to that level, based on the results as shown in Exhibit 5. Finally, the estimated values at generation are developed and compared to actual generation to obtain any difference or mismatch.

Exhibit 7 – Development of Loss Factors, Adjusted

The adjusted loss factors are the results of adjusting Exhibit 6 for any difference. All differences between estimated and actual are prorated to each level based on the ratio of each level's total load plus losses to the system total. These new loss factors reflect an adjustment in losses due only to the kW and kWh mismatch.

Exhibit 8 – Adjusted Losses and Loss Factors by Facility

These calculations present an expanded summary detail of Exhibit 7 for each segment of the power system with respect to the flow of power and associated losses from the receipt of energy at the meter to the generation for the LG&E power system.

Exhibit 9 – Summary of Losses by Delivery Voltage

These calculations present a reformatted summary of losses presented in Exhibits 7 and 8 by power system delivery segment as calculated by voltage level of service based on reported metered sales.

LG&E AND KU SERVICES COMPANY  
2010 Analysis of System Losses – LG&E Power System

---

## Appendix A

### Results of LGEE (LG&E and KU) Transmission System 2010 Loss Analysis



Exhibit No.  
Paul M. Normand  
Transmission Loss Model  
Page 1 of 17

**Louisville Gas and Electric Company (LGE)  
Kentucky Utilities Company (KU)  
2011 Transmission Loss Analysis**

<b>Pages 1-2</b>	Index
<b>Schedule 1, Page 3</b>	<p>Presents the summary loss results of the calculated hourly losses for the Company's LGE and KU control areas at the annual peak hour and for the annual average losses for all hours of the year.</p> <p>Calculated loss factors are applicable to the metered (output) sales level.</p> <p>All data is from Schedule 2.</p> <p>Section I - Summarizes the transmission loss results with GSU losses included.</p> <p>Section II - Summarizes GSU only losses.</p> <p>Section III - Summarizes the transmission only losses excluding GSU losses.</p>
<b>Schedule 1A, Page 4</b>	<p>Presents the summary loss results of the calculated hourly losses for the Company's LGE control areas at the annual peak hour and for the annual average losses for all hours of the year.</p>
<b>Schedule 1B, Page 5</b>	<p>Presents the summary loss results of the calculated hourly losses for the Company's KU control areas at the annual peak hour and for the annual average losses for all hours of the year.</p>
<b>Schedule 2, Page 6</b>	<p>Summary of the summer and winter peak hour MW and annual MWH losses for LGE and KU and the total system.</p> <p>Results are detailed by segment and season: Summer (June, July, August, and September), Winter (all months excluding Summer months).</p> <p>Loss data is from Schedule 3.</p>
<b>Schedule 3, Page 7</b>	<p>Summary of MW and MWH loss results for each control area by season and voltage level.</p>
<b>Schedule 4, Page 8</b>	<p>Summary of seasonal peak hour MW and average MWH loss results for LGE by season and voltage level.</p>



Exhibit No.  
Paul M. Normand  
Transmission Loss Model  
Page 2 of 17

**Louisville Gas and Electric Company (LGE)  
Kentucky Utilities Company (KU)  
2011 Transmission Loss Analysis**

**Schedule 5,** Summary of seasonal peak hour MW and average MWH loss results for KU by  
**Page 9** season and voltage level.

**Appendices:**

**Page 10** A - Peak Demand  
**Page 11** B - Monthly Energy  
**Page 12** C - Energy Summary  
**Page 13** D - Demand Summary

Appendices include summaries of hourly calculation of losses for each identified type at transmission voltage levels by season identified by fixed and variable with GSU losses identified separately.

**Workpapers:**

**Page 14** 1 - LGE  
**Page 15** 2 - KU

Workpapers 1 and 2 present detailed summary results of eight separate power flows for each control area (LGE and KU) for a total of sixteen unique simulations and loss results.

**Page 16** 3 - Corona Loss Calculations  
Page presents the Corona loss estimate and calculations by voltage level and control area (LGE and KU) for the peak in MW and the annual MWH for 2010.

**Page 17** Page presents the pole miles by company and voltage level.

Exhibit No.  
Paul M. Normand  
Schedule 1  
Page 3 of 17

**LGEE (LGE & KU) 2011 TRANSMISSION LOSS ANALYSIS (1)**

I TRANSMISSION LOSSES WITH GSU		LOSSES	% OF TOTAL TRANSMISSION	INPUT	OUTPUT	LOSS FACTOR (Input/Output)	
<b>A. DEMAND</b>		<u>Peak (MW) Summer (June - September)</u>					
1	LGE	57.9	27.8%	4,060	4,002	1.01448	
2	KU	150.3	72.2%	4,865	4,715	1.03187	
3	Total Demand Losses Combined (3)	208.2	100.0%	7,905	7,697	1.02705	
4	Unmetered Station Use Adjustment					0.00100	
5	Demand Loss Factor					1.02805	
<b>B. ENERGY</b>		<u>Annual MWH</u>					
6	LGE	199,404	21.5%	21,626,727	21,427,323	1.00931	
7	KU	727,568	78.5%	27,462,725	26,735,158	1.02721	
8	Total Energy Losses Combined (3)	926,971	100.0%	43,634,621	42,707,650	1.02171	
9	Unmetered Station Use Adjustment					0.00100	
10	Energy Loss Factor					1.02271	
<b>II TRANSMISSION GSU LOSSES</b>		<u>LOSSES (MW)</u>			<u>LOSSES (MWH)</u>		
<b>A. GSU LOSSES (2)</b>		FIXED	VARIABLE	TOTAL	FIXED	VARIABLE	TOTAL
11	LGE	2.90	8.50	11.40	15,715	38,826	54,541
12	KU	2.40	5.40	7.80	14,820	25,784	40,604
13	Total GSU Losses	5.30	13.90	19.20	30,535	64,610	95,145
<b>III TRANSMISSION ONLY LOSSES</b>		LOSSES	% OF TOTAL TRANSMISSION	INPUT	OUTPUT	LOSS FACTOR (Input/Output)	
<b>A. DEMAND LOSSES (Loss II-A)</b>		<u>Peak (MW) Summer (June - September)</u>					
14	LGE	46.5	24.6%	4,049	4,002	1.01163	
15	KU	142.5	75.4%	4,857	4,715	1.03021	
16	Total Demand Combined (2)	189.0	100.0%	7,886	7,697	1.02456	
17	Unmetered Station Use Adjustment					0.00100	
18	Demand Loss Factor					1.02556	
<b>B. ENERGY LOSSES (Loss II-A)</b>		<u>Annual MWH</u>					
19	LGE	144,863	17.4%	21,572,186	21,427,323	1.00676	
20	KU	686,964	82.6%	27,422,121	26,735,158	1.02570	
21	Total Energy Combined (2)	831,826	100.0%	43,539,476	42,707,650	1.01948	
22	Unmetered Station Use Adjustment					0.00100	
23	Energy Loss Factor					1.02048	

Notes:  
(1) Study Period from February 2011 through January 2012.  
(2) GSU losses from Schedule 3.  
(3) See Schedule 1A, Schedule 1B, and Schedule 2.

Exhibit No.  
Paul M. Normand  
Schedule 1A  
Page 4 of 17

**LGE 2011 TRANSMISSION LOSS ANALYSIS**

<b>I TRANSMISSION LOSSES WITH GSU</b>		<b>LOSSES</b>	<b>INPUT</b>	<b>OUTPUT</b>	<b>LOSS FACTOR (Input/Output)</b>		
<b>A. DEMAND</b>		<u>Peak (MW) Summer (June - September)</u>					
1	LGE	57.9	4,060	4,002	1.01448		
2	Unmetered Station Use Adjustment				0.00100		
3	Demand Loss Factor				1.01548		
<b>B. ENERGY</b>		<u>Annual MWH</u>					
4	LGE	199,404	21,626,727	21,427,323	1.00931		
5	Unmetered Station Use Adjustment				0.00100		
6	Energy Loss Factor				1.01031		
<b>II TRANSMISSION GSU LOSSES</b>		<u>LOSSES (MW)</u>			<u>LOSSES (MWH)</u>		
		FIXED	VARIABLE	TOTAL	FIXED	VARIABLE	TOTAL
<b>A. GSU LOSSES (1)</b>							
7	LGE	2.90	8.50	11.40	15,715	38,826	54,541
<b>III TRANSMISSION ONLY LOSSES</b>		<b>LOSSES</b>	<b>INPUT</b>	<b>OUTPUT</b>	<b>LOSS FACTOR (Input/Output)</b>		
<b>A. DEMAND LOSSES</b>		<u>Peak (MW) Summer (June - September)</u>					
8	LGE (Line 1 - Line 7)	46.5	4,049	4,002	1.01163		
9	Unmetered Station Use Adjustment				0.00100		
10	Demand Loss Factor				1.01263		
<b>B. ENERGY LOSSES</b>		<u>Annual MWH</u>					
11	LGE (Line 4 - Line 7)	144,863	21,572,186	21,427,323	1.00676		
12	Unmetered Station Use Adjustment				0.00100		
13	Energy Loss Factor				1.00776		

Notes:  
1. GSU losses from Schedule 3.  
2. See Schedule 2

Exhibit No.  
Paul M. Normand  
Schedule 1B  
Page 5 of 17

**KU 2011 TRANSMISSION LOSS ANALYSIS**

**I TRANSMISSION LOSSES WITH GSU**

	LOSSES	INPUT	OUTPUT	LOSS FACTOR (Input/Output)	
<b>A. DEMAND</b>					
<u>Peak (MW) Summer (June - September)</u>					
1	KU	150.3	4,865	4,715	1.03187
2	Unmetered Station Use Adjustment				0.00100
3	Demand Loss Factor				1.03287
<b>B. ENERGY</b>					
<u>Annual MWH</u>					
4	KU	727,568	27,462,725	26,735,158	1.02721
5	Unmetered Station Use Adjustment				0.00100
6	Energy Loss Factor				1.02821

**II TRANSMISSION GSU LOSSES**

	LOSSES (MW)			LOSSES (MWH)			
	FIXED	VARIABLE	TOTAL	FIXED	VARIABLE	TOTAL	
<b>A. GSU LOSSES (1)</b>							
7	KU	2.40	5.40	7.80	14,820	25,784	40,604

**III TRANSMISSION ONLY LOSSES**

	LOSSES	INPUT	OUTPUT	LOSS FACTOR (Input/Output)	
<b>A. DEMAND LOSSES</b>					
<u>Peak (MW) Summer (June - September)</u>					
8	KU (Line 1 - Line 7)	142.5	4,857	4,715	1.03021
9	Unmetered Station Use Adjustment				0.00100
10	Demand Loss Factor				1.03121
<b>B. ENERGY LOSSES</b>					
<u>Annual MWH</u>					
11	KU (Line 4 - Line 7)	686,964	27,422,121	26,735,158	1.02570
12	Unmetered Station Use Adjustment				0.00100
13	Energy Loss Factor				1.02670

Notes:

1. GSU losses from Schedule 3.
2. See Schedule 2

Exhibit No.  
Paul M. Normand  
Schedule 2  
Page 6 of 17

**LGEE (LGE & KU) POWER FLOW RESULTS - SUMMARY OF LOSSES**

TRANSMISSION LOSSES WITH GSU	PEAK (SUMMER)		PEAK (OTHER)		ANNUAL	
	Total (MW)	% of Total System Losses	Total (MW)	% of Total System Losses	Total Annual (MWH)	% of Total System Losses
<u>LGE</u>						
1 Transmission Use (Peak MW, Annual MWH)	4,002		3,300		21,427,323	
2 Input (Line 1 + Line 5)	4,060		3,328		21,626,727	
Transmission						
3 Fixed	5.9	2.9%	5.2	2.3%	43,657	4.7%
4 Variable	52.0	25.0%	22.5	10.0%	155,747	16.8%
5 Total Transmission - LGE	57.9	27.8%	27.7	12.3%	199,404	21.5%
6 Losses % of Input (Line 5/Line 2)	1.43%		0.83%		0.92%	
7 Losses % of Output (Line 5/Line 1)	1.45%		0.84%		0.93%	
<u>KU</u>						
8 Transmission Use (Peak MW, Annual MWH)	4,715		4,961		26,735,158	
9 Input (Line 8 + Line 12)	4,865		5,159		27,462,725	
Transmission						
10 Fixed	8.2	3.9%	8.1	3.6%	67,476	7.3%
11 Variable	142.0	68.2%	190.0	84.1%	660,091	71.2%
12 Total Transmission - KU	150.3	72.2%	198.1	87.7%	727,568	78.5%
13 Losses % of Input (Line 12/Line 9)	3.09%		3.84%		2.65%	
14 Losses % of Output (Line 2/Line 8)	3.19%		3.99%		2.72%	
<u>TOTAL LGE &amp; KU</u>						
15 LGEE Load (Peak MW, Annual MWH) Input	8,925		8,487		49,089,452	
16 LGE Energy Delivery to KU	-1,020		-1,228		-5,454,831	
17 Total Load (Peak MW, Annual MWH)	7,905		7,259		43,634,621	
Transmission						
18 Fixed	14.2	6.8%	13.4	5.9%	111,133	12.0%
19 Variable	194.0	93.2%	212.5	94.1%	815,838	88.0%
20 Total System	208.2	100.0%	225.9	100.0%	926,971	100.0%
21 Losses % of Input (Line 20/Line 15)	2.33%		2.66%		1.89%	
22 Losses % of Output (Line 20/(Line 15/Line 20))	2.39%		2.73%		1.92%	
<u>COMBINED LGEE DELIVERED ENERGY &amp; LOSSES</u>						
	<u>SUMMER</u>		<u>WINTER</u>		<u>ANNUAL</u>	
23 LGEE Load (All data in MWH) Output	17,146,907		31,015,574		48,162,481	
24 LGE Energy Delivery to KU	-1,689,262		-3,765,569		-5,454,831	
25 Total Load (Annual MWH) Output	15,457,645		27,250,005		42,707,650	
Transmission Losses						
26 Fixed	37,940	11.1%	73,193	12.5%	111,133	12.0%
27 Variable	303,970	88.9%	511,869	87.5%	815,838	88.0%
28 Total Transmission Losses	341,909	100.0%	585,062	100.0%	926,971	100.0%
29 Losses % of Output (Line 28/Line 23)	1.99%		1.89%		1.92%	

Exhibit No.  
Paul M. Normand  
Schedule 3  
Page 7 of 17

**LGEE (LGE & KU) POWER FLOW RESULTS - TOTAL TRANSMISSION**

**CONDUCTOR AND TRANSFORMER LOSSES (MW)**

TIME	MW TRANSMISSION USE	Transmission Fixed	Transmission Variable	GSU Fixed	GSU Variable	Subtotal Conductor & Transformer	Load Adjustment for Combined Only
<b>OTHER - LGE</b>							
1 PEAK - MW	3,300	3.15	16.50	2.10	6.00	27.75	1228.00
2 LOSS % TO LOAD		0.095%	0.500%	0.064%	0.182%	0.841%	
3 LOSS % TO TOTAL LOSSES		11.349%	59.461%	7.568%	21.622%	100.000%	
4							
5 OTHER MWH	13,679,183	18,668	63,034	10,054	24,023	115,779	3,765,569
6 LOSS % TO LOAD		0.136%	0.461%	0.073%	0.176%	0.846%	
7 LOSS % TO TOTAL LOSSES		16.124%	54.443%	8.684%	20.749%	100.000%	
<b>SUMMER - LGE</b>							
8 PEAK - MW	4,002	3.05	43.50	2.90	8.50	57.95	1020.00
9 LOSS % TO LOAD		0.076%	1.087%	0.072%	0.212%	1.448%	
10 LOSS % TO TOTAL LOSSES		5.262%	75.066%	5.004%	14.668%	100.000%	
11							
12 SUMMER MWH	7,748,140	9,274	53,887	5,661	14,803	83,625	1,689,262
13 LOSS % TO LOAD		0.120%	0.695%	0.073%	0.191%	1.079%	
14 LOSS % TO TOTAL LOSSES		11.090%	64.439%	6.770%	17.702%	100.000%	
<b>TOTAL ANNUAL - LGE</b>							
15 SUMMER PEAK - MW	4,002	3.05	43.50	2.90	8.50	57.95	1020.00
16 ANNUAL MWH	21,427,323	27,942	116,921	15,715	38,826	199,404	5,454,831
17 LOSS % TO TOTAL ANNUAL OUTPUT		0.130%	0.546%	0.073%	0.181%	0.931%	
<b>LOSS FACTORS - LGE</b>							
18 Demand						1.01448	
19 Energy						1.00931	
<b>OTHER - KU</b>							
20 PEAK - MW	4,961	5.81	183.94	2.30	6.10	198.15	
21 LOSS % TO LOAD		0.117%	3.708%	0.046%	0.123%	3.994%	
22 LOSS % TO TOTAL		2.930%	92.831%	1.161%	3.079%	100.000%	
23							
24 OTHER MWH	17,336,391	35,105	408,661	9,366	16,151	469,283	
25 LOSS % TO LOAD		0.202%	2.357%	0.054%	0.093%	2.707%	
26 LOSS % TO TOTAL LOSSES		7.481%	87.082%	1.996%	3.442%	100.000%	
<b>SUMMER - KU</b>							
27 PEAK - MW	4,715	5.81	136.65	2.40	5.40	150.25	
28 LOSS % TO LOAD		0.123%	2.898%	0.051%	0.115%	3.187%	
29 LOSS % TO TOTAL		3.864%	90.945%	1.597%	3.594%	100.000%	
30							
31 SUMMER MWH	9,398,766	17,551	225,647	5,454	9,633	258,285	
32 LOSS % TO LOAD		0.187%	2.401%	0.058%	0.102%	2.748%	
<b>TOTAL ANNUAL - KU</b>							
33 PEAK - MW	4,715	5.81	136.65	2.40	5.40	150.25	
34 ANNUAL MWH	26,735,158	52,656	634,307	14,820	25,784	727,568	
35 LOSS % TO TOTAL ANNUAL OUTPUT		0.197%	2.373%	0.055%	0.096%	2.721%	
<b>LOSS FACTORS - KU</b>							
36 Demand						1.03187	
37 Energy						1.02721	
<b>TOTAL ANNUAL - LGEE OUTPUT &amp; LOSSES</b>							
38 PEAK SUMMER - MW	8,717	8.86	180.15	5.30	13.90	208.20	1020.00
39 SUMMER MWH	17,146,907	26,825	279,534	11,115	24,436	341,909	1,689,262
40 PEAK OTHER MW	8,262	8.96	200.44	4.40	12.10	225.90	1228.00
41 OTHER MWH	31,015,574	53,773	471,695	19,420	40,174	585,062	3,765,569
42 ANNUAL MWH	48,162,481	80,598	751,228	30,535	64,610	926,971	5,454,831

Exhibit No.  
Paul M. Normand  
Schedule 4  
Page 8 of 17

**LGE POWER FLOW RESULTS**

**CONDUCTOR AND TRANSFORMER LOSSES (MW)**

TIME	MW-LGE TRANSMISSION USE	Transmission Fixed (4)	Transmission Variable	GSU Fixed	GSU Variable	Subtotal Conductor & Transformer
<b>OTHER - LGE</b>						
1 PEAK - MW	3,300	3.15	16.50	2.10	6.00	27.75
2 LOSS % TO LOAD		0.095%	0.500%	0.064%	0.182%	0.841%
3 LOSS % TO TOTAL LOSSES		11.349%	59.461%	7.568%	21.622%	100.000%
4						
5 OTHER MWH	13,679,183	18,668	63,034	10,054	24,023	115,779
6 LOSS % TO LOAD		0.136%	0.461%	0.073%	0.176%	0.846%
7 LOSS % TO TOTAL LOSSES		16.124%	54.443%	8.684%	20.749%	100.000%
<b>SUMMER - LGE</b>						
8 PEAK - MW	4,002	3.05	43.50	2.90	8.50	57.95
9 LOSS % TO LOAD		0.076%	1.087%	0.072%	0.212%	1.448%
10 LOSS % TO TOTAL LOSSES		5.262%	75.066%	5.004%	14.668%	100.000%
11						
12 SUMMER MWH	7,748,140	9,274	53,887	5,661	14,803	83,625
13 LOSS % TO LOAD		0.120%	0.695%	0.073%	0.191%	1.079%
14 LOSS % TO TOTAL LOSSES		11.090%	64.439%	6.770%	17.702%	100.000%
<b>TOTAL ANNUAL - LGE</b>						
15 SUMMER PEAK - MW	4,002	3.05	43.50	2.90	8.50	57.95
16 LOSS % TO SUMMER PEAK MW		0.076%	1.087%	0.072%	0.212%	1.448%
17 ANNUAL MWH	21,427,323	27,942	116,921	15,715	38,826	199,404
18 LOSS % TO ANNUAL MWH		0.130%	0.546%	0.073%	0.181%	0.931%
<b>LOSS FACTORS - LGE</b>						
19 Demand						1.01448
20 Energy						1.00931

**NOTES:**

- (1) Summer Period includes June, July, August, and September.
- (2) Other Period includes all non Summer Period months.
- (3) Transmission Use = Load + Exports + Passthroughs
- (4) Transmission Fixed includes Corona Losses

Exhibit No.  
Paul M. Normand  
Schedule 5  
Page 9 of 17

**KU POWER FLOW RESULTS**

**CONDUCTOR AND TRANSFORMER LOSSES (MW)**

TIME	MW-KU TRANSMISSION USE	Transmission Fixed (4)	Transmission Variable (5)	GSU Fixed	GSU Variable	Subtotal Conductor & Transformer	
<b>OTHER - KU</b>							
1	PEAK - MW	4,961	5.81	183.94	2.30	6.10	198.15
2	LOSS % TO LOAD		0.117%	3.708%	0.046%	0.123%	3.994%
3	LOSS % TO TOTAL LOSSES		2.930%	92.831%	1.161%	3.079%	100.000%
4							
5	OTHER MWH	17,336,391	35,105	408,661	9,366	16,151	469,283
6	LOSS % TO LOAD		0.202%	2.357%	0.054%	0.093%	2.707%
7	LOSS % TO TOTAL LOSSES		7.481%	87.082%	1.996%	3.442%	100.000%
<b>SUMMER - KU</b>							
8	PEAK - MW	4,715	5.81	136.65	2.40	5.40	150.25
9	LOSS % TO LOAD		0.123%	2.898%	0.051%	0.115%	3.187%
10	LOSS % TO TOTAL LOSSES		3.864%	90.945%	1.597%	3.594%	100.000%
11							
12	SUMMER MWH	9,398,766	17,551	225,647	5,454	9,633	258,285
13	LOSS % TO LOAD		0.187%	2.401%	0.058%	0.102%	2.748%
14	LOSS % TO TOTAL LOSSES		6.795%	87.364%	2.112%	3.730%	100.000%
<b>TOTAL ANNUAL - KU</b>							
15	SUMMER PEAK - MW	4,715	5.81	136.65	2.40	5.40	150.25
16	LOSS % TO SUMMER PEAK MW		0.123%	2.898%	0.051%	0.115%	3.187%
17	ANNUAL MWH	26,735,158	52,656	634,307	14,820	25,784	727,568
18	LOSS % TO ANNUAL MWH		0.197%	2.373%	0.055%	0.096%	2.721%
<b>LOSS FACTORS - KU</b>							
19	Demand						1.03187
20	Energy						1.02721

**NOTES:**

- (1) Summer Period includes June, July, August, and September.
- (2) Other Period includes all non Summer Period months.
- (3) Transmission Use = Load + Exports + Passthroughs
- (4) Transmission Fixed includes Corona Losses
- (5) Transmission Variable includes Losses at 0.5% from Appendix A (MW) and Appendix B (MWH)



Exhibit No.  
Paul M. Normand  
Appendix A  
Page 10 of 17

Kentucky Utilities	OTHER	SUMMER	OTHER	SUMMER
	2/11/11 8:00 February-11	7/11/11 16:00 July-11		
<b>Loads:</b>				
1 KU Load (including losses)	4,292	4,102		
2 EKPC on KU	446	355		
3 TVA on KU	59	58		
4 OMU Load (3%)	-	12		
5 BREC on KU	6	6		
6 KMPA Load (3%)	108	129		
7 Total Load	<u>4,911</u>	<u>4,662</u>	4,911.00	4,662.00
<b>Export (Delivered):</b>				
8 KU Off-System Sales	-	-		
9 AMEM - Pass Through	-	-		
10 CARGILL - Pass Through	-	-		
11 OMU Exports	249	204		
12 KMPA Exports	-	-		
13 Constellation - Pass Through	-	-		
14 TEA - Pass Through	-	-		
15 TVA (OATT) - Pass Through	-	-		
16 Total Exports	<u>249</u>	<u>204</u>	249.00	204.00
17 BTM (0.5%) - OMU Network Load	112	182		
18 BTM (0.5%) - KMPA Gen	-	49		
19 Total BTM	<u>112</u>	<u>231</u>		
20 Losses at 0.5%	0.560	1.155	5,160.00	4,866.00
21 Losses from Schedule 5, Lines 1 and 8			<u>-198.71</u>	<u>-151.41</u>
22 Peak MW Load			<u>4,961.29</u>	<u>4,714.59</u>
<b>Louisville Gas and Electric</b>				
<b>Loads:</b>				
23 LGE Load (including losses)	1,725	2,654		
23 EKPC on LGE	61	77		
24 Hoosier on LGE	5	6		
25 Total Load	<u>1,791</u>	<u>2,737</u>	1,791.00	2,737.00
<b>Export (Delivered):</b>				
26 IMEA	146	146		
27 IMPA	155	157		
28 LGE Off-System Sales	8	-		
29 OVEC to SIGE	-	-		
30 Total Exports	<u>309</u>	<u>303</u>	309.00	303.00
31 LGE to KU	1,228	1,020	<u>1,228.00</u>	<u>1,020.00</u>
32 Losses from Schedule 4, Lines 1 and 8			<u>3,328.00</u>	<u>4,060.00</u>
33 Peak MW Load			<u>-27.75</u>	<u>-57.95</u>
			<u>3,300.25</u>	<u>4,002.05</u>

Notes:

- (1) Information above was gathered through the Peak Load spreadsheet which is used for FERC Form 1 data collection. Additionally, information was gathered from the individual billings each month, which also flows into FERC Form 1.
- (2) OSS information was gathered through multiple spreadsheets from Revenue Accounting and Transmission groups.

Exhibit No.  
Paul M. Normand  
Appendix B  
Page 11 of 17

**Kentucky Utilities**

Prepared by: FR/DH

	February-11	March-11	April-11	May-11	June-11	July-11	August-11	September-11	October-11	November-11	December-11	January-12	Total	Other	Summer
<b>Loads:</b>															
1 KU Load (including losses)	1,882,033	1,838,010	1,567,127	1,688,187	1,906,541	2,167,087	2,097,914	1,653,158	1,650,548	1,687,623	1,918,215	2,083,767	22,140,210		
2 EKPC on KU	192,766	183,756	155,967	163,451	164,293	182,579	182,121	147,273	142,289	161,421	192,322	213,632	2,081,870		
3 TVA on KU	30,019	26,656	20,497	22,985	27,885	34,587	29,211	21,634	19,664	26,719	36,278	34,830	330,965		
4 OMU Load (3%)	-	-	-	555	-	1,043	1,328	365	6,757	-	-	-	9,848		
5 BRCC on KU	3,047	2,972	2,440	2,382	2,575	2,943	3,367	3,272	3,715	2,495	3,797	4,364	37,370		
6 KMPA Load (3%)	53,933	54,624	50,868	58,455	71,032	79,177	77,514	57,137	49,740	51,011	56,115	56,274	715,880		
<b>7 Total Load</b>	<b>2,161,798</b>	<b>2,106,018</b>	<b>1,796,898</b>	<b>1,936,015</b>	<b>2,172,326</b>	<b>2,467,416</b>	<b>2,391,455</b>	<b>1,882,639</b>	<b>1,872,713</b>	<b>1,929,269</b>	<b>2,206,727</b>	<b>2,392,867</b>	<b>25,316,143</b>	<b>16,402,307</b>	<b>8,913,836</b>
<b>Export (Delivered):</b>															
8 KU Off-System Sales	10,003	1,971	14	13,001	23,568	12,175	4,828	384	29,307	2,890	542	265	98,948		
9 AMEM - Pass Through	-	-	2,400	-	-	-	-	-	12,000	2,400	11,338	51,500	79,638		
10 CARGILL - Pass Through	31,261	100	-	23,399	2,400	-	-	-	20,527	13,749	70	-	91,506		
11 OMU Exports	165,206	183,023	175,905	50,051	156,463	143,444	137,842	155,042	106,507	137,874	176,030	158,940	1,746,327		
12 KMPA Exports	-	-	-	-	-	-	-	-	59	-	-	-	59		
13 Constellation - Pass Through	-	-	-	11,734	4,740	24,485	34,163	25,048	34,099	-	-	-	134,269		
14 TEA - Pass Through	-	-	-	-	-	-	-	-	59	66	-	-	125		
15 TVA (QATT) - Pass Through	-	-	308	-	-	-	-	-	-	-	-	-	308		
<b>16 Total Exports</b>	<b>206,470</b>	<b>185,094</b>	<b>178,627</b>	<b>98,185</b>	<b>187,171</b>	<b>180,104</b>	<b>176,833</b>	<b>201,001</b>	<b>195,780</b>	<b>143,300</b>	<b>187,910</b>	<b>210,705</b>	<b>2,151,180</b>	<b>1,406,071</b>	<b>745,109</b>
17 BTM (0.5%) - OMU Network Load	64,375	67,851	62,989	71,662	86,097	103,156	96,293	73,876	61,587	65,420	69,832	70,719	893,857		
18 BTM (0.5%) - KMPA Gen	-	-	-	1,054	4,315	8,837	4,422	858	1,839	-	1,479	1,872	25,677		
<b>19 Total BTM</b>	<b>64,375</b>	<b>67,851</b>	<b>62,989</b>	<b>72,716</b>	<b>90,412</b>	<b>112,993</b>	<b>100,715</b>	<b>74,734</b>	<b>63,426</b>	<b>65,420</b>	<b>71,311</b>	<b>72,591</b>	<b>919,534</b>		
20 Losses at 0.5%	322	339	315	364	452	565	504	374	317	327	357	363	4,598		
21 Total MWH Input													17,808,378	9,658,945	
22 Losses from Schedule 5, Lines 5 and 12													-471,986	-260,179	
23 Total MWH Output													17,336,391	9,398,766	

**Louisville Gas and Electric**

	February-11	March-11	April-11	May-11	June-11	July-11	August-11	September-11	October-11	November-11	December-11	January-12	Total	Other	Summer
<b>Loads:</b>															
23 LGE Load (including losses)	903,869	935,217	852,840	998,568	1,189,433	1,431,090	1,316,506	968,118	877,979	870,461	958,046	988,020	12,290,147		
24 EKPC on LGE	25,617	24,530	20,953	24,482	30,141	37,883	33,856	23,583	21,869	22,649	27,706	29,346	322,615		
25 Hoosier on LGE	3,006	3,093	2,628	3,247	3,465	3,908	3,767	3,220	3,081	2,998	3,210	3,263	38,886		
<b>26 Total Load</b>	<b>932,492</b>	<b>962,840</b>	<b>876,421</b>	<b>1,026,297</b>	<b>1,223,039</b>	<b>1,472,881</b>	<b>1,354,129</b>	<b>994,921</b>	<b>902,929</b>	<b>896,108</b>	<b>988,962</b>	<b>1,020,629</b>	<b>12,651,648</b>	<b>7,606,677</b>	<b>5,044,971</b>
<b>Export (Delivered):</b>															
27 IMEA	87,925	74,691	45,921	89,073	102,288	100,626	86,582	74,691	75,238	61,640	90,715	99,872	989,262		
28 IMPA	93,431	79,319	48,912	94,516	107,515	106,729	90,741	77,329	79,575	65,340	97,587	105,971	1,046,965		
29 LGE Off-System Sales	155,240	139,458	45,904	124,917	96,244	96,890	49,158	108,739	205,726	207,341	158,716	95,688	1,484,021		
30 DVEC to SIGE	-	-	-	-	-	-	-	-	-	-	-	-	-		
<b>31 Total Exports</b>	<b>336,596</b>	<b>293,468</b>	<b>140,737</b>	<b>308,506</b>	<b>306,047</b>	<b>304,245</b>	<b>226,481</b>	<b>260,759</b>	<b>360,539</b>	<b>334,321</b>	<b>347,018</b>	<b>301,531</b>	<b>3,520,248</b>	<b>2,422,716</b>	<b>1,097,532</b>
32 LGE to KU	484,518	444,877	370,225	397,072	364,002	440,065	446,201	438,994	458,456	438,203	561,790	610,428	5,454,831	3,765,569	1,689,262
33 Total MWH Input													13,794,962	7,831,765	
34 Losses from Schedule 4, Lines 5 and 12													-115,779	-83,625	
35 Total MWH Output													13,679,183	7,748,140	

Information above was gathered through the Peak Load spreadsheet which is used for FERC Form 1 data collection. Additionally, information was gathered from the individual billings each month, which also flows into FERC Form 1. OSS information was gathered through multiple spreadsheets from Revenue Accounting and Transmission groups.

Exhibit No.  
Paul M. Normand  
Appendix C  
Page 12 of 17

**LGEE Loss Summary**

LGE Loss Summary			Transmission Losses		Generation Losses	
Season	Month		Fixed	Variable	Fixed	Variable
1	O	01	1,944	8,405	1,405	3,124
2	O	02	1,753	7,950	1,165	3,114
3	O	03	1,970	8,159	1,205	3,317
4	O	04	1,923	6,323	1,217	2,547
5	O	05	1,978	9,932	1,207	3,076
6	S	06	1,877	13,384	1,289	3,615
7	S	07	1,933	16,655	1,542	4,380
8	S	08	1,940	15,067	1,454	3,936
9	S	09	1,915	8,781	1,376	2,872
10	O	10	1,999	7,087	1,180	2,917
11	O	11	1,937	6,926	1,273	2,856
12	O	12	1,960	8,252	1,402	3,072
13		Total	23,129	116,921	15,715	38,826
14		Summer Corona	1,609			
15	S	Total LGE Summer	9,274	53,887	5,661	14,803
16		Other Corona	3,204			
17	O	Total LGE Other	18,668	63,034	10,054	24,023

KU Loss Summary			Transmission Losses		Generation Losses	
Season	Month		Fixed	Variable	Fixed	Variable
18	O	01	3,246	66,020	1,272	2,314
19	O	02	2,937	65,153	1,209	2,146
20	O	03	3,279	51,357	1,244	2,220
21	O	04	3,200	40,542	1,058	1,929
22	O	05	3,312	41,568	1,190	2,000
23	S	06	3,155	59,549	1,405	2,449
24	S	07	3,247	64,025	1,459	2,832
25	S	08	3,260	61,754	1,436	2,666
26	S	09	3,187	42,213	1,154	1,686
27	O	10	3,306	42,719	1,079	1,752
28	O	11	3,189	49,382	1,089	1,865
29	O	12	3,271	54,623	1,225	1,925
30		Total	38,589	638,905	14,820	25,784
31		Summer Corona	4,702			
32	S	Total KU Summer	17,551	227,541	5,454	9,633
33		Other Corona	9,365			
34	O	Total KU Other	35,105	411,364	9,366	16,151

LGEE Loss Summary			Transmission Losses		Generation Losses	
Season	Month		Fixed	Variable	Fixed	Variable
35	O	01	5,190	74,425	2,677	5,438
36	O	02	4,690	73,103	2,374	5,260
37	O	03	5,249	59,516	2,449	5,537
38	O	04	5,123	46,865	2,275	4,476
39	O	05	5,290	51,500	2,397	5,076
40	S	06	5,032	72,933	2,694	6,064
41	S	07	5,180	80,680	3,001	7,212
42	S	08	5,200	76,821	2,890	6,602
43	S	09	5,102	50,994	2,530	4,558
44	O	10	5,305	49,806	2,259	4,669
45	O	11	5,126	56,308	2,362	4,721
46	O	12	5,231	62,875	2,627	4,997
47		Total	61,718	755,826	30,535	64,610
48		Summer Corona	6,311			
49	S	Total LGEE Summer	26,825	281,428	11,115	24,436
50		Other Corona	12,569			
51	O	Total LGEE Other	53,773	474,398	19,420	40,174

Notes:  
(1) Includes Corona Losses from Workpaper 3

Exhibit No.  
Paul M. Normand  
Appendix D  
Page 13 of 17

Summer Peak Hour 2011-07-11-1600

		Transmission Losses		Generation Losses	
		Fixed (1)	Variable	Fixed	Variable
1	KU	5.8	137.8	2.4	5.4
2	LG&E	3.0	43.5	2.9	8.5
3	Combined	8.9	181.3	5.3	13.9

Winter Peak Hour 2011-02-11-0800

		Transmission Losses		Generation Losses	
		Fixed (1)	Variable	Fixed	Variable
4	KU	5.8	184.5	2.3	6.1
5	LG&E	3.1	16.5	2.1	6.0
6	Combined	9.0	201.0	4.4	12.1

		Corona Losses (MW)
		Fixed (1)
7	KU	1.606
8	LG&E	0.549
9	Combined	2.155

Notes:  
(1) Includes Corona Losses from Workpaper 3

Exhibit No.  
 Paul M. Normand  
 Workpaper 1  
 Page 14 of 17

Hour	LG&E Load	KU on LG&E	EKPC on LG&E	HE on LG&E	LG&E T Loss-f	LG&E T Loss-v	LG&E G Loss-f	LG&E G Loss-v	Net Export	BLG Export	Month
2011-02-01-0100	1217.7	6.3	35.6	4.3	2.6	11.5	1.7	4.6	1394.6	0	02
2011-02-01-0200	1179.1	6	34.4	4.4	2.6	11	1.7	4.4	1373.9	0	02
2011-02-01-0300	1147.9	5.8	33.6	4	2.6	10.8	1.7	4.3	1354.7	0	02
2011-02-01-0400	1138.1	5.6	33	4	2.6	11.6	1.7	4.3	1374.9	0	02
2011-02-01-0500	1149.1	5.7	33.8	3.9	2.6	12	1.7	4.5	1398.1	0	02
2011-02-01-0600	1201.1	6	37.3	4	2.6	12.5	1.7	4.6	1379.2	0	02
2011-02-01-0700	1347.6	6.8	41.9	4.1	2.6	15.3	1.7	5.6	1454.3	0	02
2011-02-01-0800	1429.8	7.2	43.4	4.3	2.6	15.6	1.7	5.6	1354.1	0	02
2011-02-01-0900	1431	7.1	41.9	4.7	2.6	15.6	1.7	5.5	1329.5	0	02
2011-02-01-1000	1424.8	7	41	4.6	2.6	15.4	1.7	5	1236.6	0	02
2011-02-01-1100	1440.5	7	40.8	4.6	2.6	14	1.7	4.6	1122.7	0	02
2011-02-01-1200	1442.4	6.9	40.3	4.5	2.6	14.3	1.7	4.7	1132	0	02
2011-02-01-1300	1438.7	6.8	40.3	4.5	2.6	14.5	1.7	4.8	1159.1	0	02
2011-02-01-1400	1394.7	6.7	39.4	4.4	2.6	13.6	1.7	4.6	1138.9	0	02
2011-02-01-1500	1371.6	6.6	39	4.6	2.6	13.2	1.7	4.3	1098	0	02
2011-02-01-1600	1388.5	6.7	39.7	4.6	2.6	13.2	1.7	4.2	1038.9	0	02
2011-02-01-1700	1408.8	6.8	41.6	4.3	2.6	13.5	1.7	4.3	1064.8	0	02
2011-02-01-1800	1448.7	7	44.2	4.3	2.6	14.7	1.7	4.6	1129.1	0	02
2011-02-01-1900	1483.7	7.2	45.7	4.4	2.6	15.1	1.7	4.8	1162.1	0	02
2011-02-01-2000	1450.8	7.1	45.2	4.7	2.6	15	1.7	4.6	1149.2	0	02
2011-02-01-2100	1414.2	7	44	4.7	2.6	14.5	1.7	4.6	1163.9	0	02
2011-02-01-2200	1337.9	6.6	41.1	4.6	2.6	12.8	1.7	4.5	1190.9	0	02
2011-02-01-2300	1255.5	6.1	37.2	4.2	2.6	11.5	1.7	4.1	1168.2	0	02
2011-02-02-0000	1140.4	5.7	32.8	4	2.6	9	1.7	3.4	1062.1	0	02
2011-02-02-0100	1076.3	5.4	30.7	4.3	2.6	8.1	1.7	3.2	1029.2	0	02
2011-02-02-0200	1046.7	5.3	30.5	4.2	2.6	7.9	2.1	3.3	1168.7	0	02
2011-02-02-0300	1071.2	5.4	32.4	4.1	2.6	8.1	2.1	3.5	1273.5	0	02
2011-02-02-0400	1101.7	5.7	35.5	4.2	2.6	8.3	2	3.6	1282.3	0	02
2011-02-02-0500	1162.1	6.1	38.3	4.3	2.6	9.4	2.1	4.2	1451.1	0	02
2011-02-02-0600	1230.2	7	42.9	4.5	2.6	10.5	2.1	4.6	1495.4	0	02
2011-02-02-0700	1387.9	8.1	49.3	4.7	2.6	13.1	2.1	5.6	1531.5	0	02
2011-02-02-0800	1502.7	9	51.8	4.6	2.6	15.4	2.1	6.5	1611.9	0	02
2011-02-02-0900	1511.5	9	50.4	4.6	2.6	15.2	2.1	6.3	1585.1	0	02
2011-02-02-1000	1514.9	9.3	49.8	4.8	2.6	15.1	2.1	6.2	1560.6	0	02
2011-02-02-1100	1544.2	9.1	49.4	4.9	2.6	15.6	2.1	6.4	1580	0	02
2011-02-02-1200	1552	9.1	49	4.7	2.6	15.7	2.1	6.4	1549	0	02
2011-02-02-1300	1558.5	9	48.6	4.5	2.6	15.9	2.1	6.8	1617.1	0	02
2011-02-02-1400	1559.7	8.9	48.3	4.5	2.6	16	2.1	6.7	1606.8	0	02
2011-02-02-1500	1554.9	8.8	47.3	4.5	2.6	15.8	2.1	6.6	1601.7	0	02
2011-02-02-1600	1538.9	8.7	47.9	4.6	2.6	15.6	2.1	6.5	1595	0	02
2011-02-02-1700	1537.9	8.6	50.4	5	2.6	15.6	2.1	6.9	1654.1	0	02
2011-02-02-1800	1556.3	9	52.5	5	2.6	15.6	2.1	6.7	1595.9	0	02
2011-02-02-1900	1616.8	9.4	56.5	5	2.6	16.6	2.1	6.5	1492.9	0	02
2011-02-02-2000	1618.7	9.4	57.6	5	2.6	16.6	2.1	6.5	1486	0	02

Exhibit No.  
Paul M. Normand  
Workpaper 2  
Page 15 of 17

Hour	KU Load	KU on LG&E	KU on EKPC	EKPC on KU	BREC on KU	TVA on KU	OMU on KU	KMPA on KU	KUT Loss-f	KUT Loss-v	KU G Loss-f	KU G Loss-v	Net Export	OMU Export	PADP Gen	Month
2011-02-01-0100	2345.7	6.3	59.6	280.6	5	37.6	82	68.6	4.4	85.8	1.9	2.1	-1050.5	146.1	0	02
2011-02-01-0200	2259.9	6	57.9	265.6	4.9	35.2	83.5	65	4.4	82.9	1.9	1.9	-924.7	200.2	0	02
2011-02-01-0300	2191.3	5.8	56.9	257.6	4.7	33.7	82.5	63.8	4.4	82.7	1.9	1.8	-891.2	209	0	02
2011-02-01-0400	2131.8	5.6	56.5	257.6	4.7	32.5	83.8	63.4	4.4	88.1	1.9	1.9	-713	261.3	0	02
2011-02-01-0500	2137.1	5.7	56.5	259.3	4.5	32.5	85.3	64.1	4.4	88	1.9	2.1	-658.3	285.5	0	02
2011-02-01-0600	2244.3	6	58.2	274.8	5.3	33.8	86.3	66.1	4.4	92.3	1.9	2.3	-679.2	282.5	0	02
2011-02-01-0700	2500.3	6.8	62.4	286.8	5.5	37.6	91.7	72.1	4.3	103.6	1.9	3.5	-549.8	277.5	0	02
2011-02-01-0800	2682.1	7.2	67.2	271.4	5.6	43	102.2	82.5	4.3	100	1.9	3.5	-768.4	277	0	02
2011-02-01-0900	2691.9	7.1	68.7	287	5.7	40.3	110.7	88.1	4.3	100.7	1.9	3.5	-802.1	259.3	0	02
2011-02-01-1000	2698.6	7	69	273.9	6.1	38.8	111.1	91.6	4.3	100.1	1.9	3.5	-811.1	222.6	0	02
2011-02-01-1100	2693.2	7	68.6	279.1	5.4	38.7	111.1	92.6	4.4	92.6	1.9	3.1	-1025.6	139.2	0	02
2011-02-01-1200	2651	6.9	67.8	248.7	5.9	38.1	111	93.1	4.4	90.2	1.9	3	-973.1	146.9	0	02
2011-02-01-1300	2613.9	6.8	67	275.6	6	37.6	110	93.3	4.4	90.3	1.8	3.2	-891.5	181	0	02
2011-02-01-1400	2572.4	6.7	66.8	272.8	5.7	37.1	108.8	92.7	4.4	85.9	1.8	2.9	-969.7	143.2	0	02
2011-02-01-1500	2589.4	6.6	67.4	265.5	5.9	36.7	111.3	91.2	4.4	86.2	1.8	3.1	-898.7	166	0	02
2011-02-01-1600	2575.3	6.7	66.9	274.1	6.1	36.9	111.4	89.8	4.4	88.3	1.8	3.3	-812.7	181	0	02
2011-02-01-1700	2602.6	6.8	67.8	275.4	6.3	38.4	108.4	87.5	4.4	91.7	1.8	3.4	-803	190.5	0	02
2011-02-01-1800	2624.9	7	68.9	238.4	5.8	41.1	109.3	86.5	4.4	94.1	1.8	3.5	-723.5	205.5	0	02
2011-02-01-1900	2663.8	7.2	69.2	302.1	5.5	43.6	111.1	87.6	4.4	92.3	1.8	3.7	-789.1	204.2	0	02
2011-02-01-2000	2622.6	7.1	68.4	289	5.7	44.3	112.1	87.7	4.4	93.4	1.8	3.6	-713.7	256.7	0	02
2011-02-01-2100	2563.1	7	66.5	273.6	6	43.4	110.2	89.2	4.4	90.2	1.8	3.4	-687.2	282	0	02
2011-02-01-2200	2507.5	6.6	64.8	209.9	6.6	42.3	103.5	89.6	4.4	82.9	1.8	3	-751.7	205	0	02
2011-02-01-2300	2368.7	6.1	61.7	207	6	40.3	99.1	87.9	4.4	79.3	1.8	2.5	-830.1	182.7	0	02
2011-02-02-0000	2254.8	5.7	59.2	259.1	6.1	39.4	100.7	85.1	4.4	67.9	1.8	1.7	-1208.7	5.4	0	02
2011-02-02-0100	2176.4	5.4	57.5	224.2	5	38.8	96.9	81.1	4.4	58.5	1.8	1.6	-1101	62.2	0	02
2011-02-02-0200	2133.6	5.3	56.1	215.2	5.4	41	96.4	79.9	4.4	65.9	1.8	1.8	-950.7	105.5	0	02
2011-02-02-0300	2110	5.4	57.9	216.3	5.3	44.4	98.6	79.9	4.4	68.5	1.8	1.7	-899.7	151.2	0	02
2011-02-02-0400	2176.8	5.7	60.6	227	5.2	47	96.1	79.4	4.4	69.7	1.8	1.8	-955	156	0	02
2011-02-02-0500	2336.8	6.1	63.4	169.1	5	48.8	95.2	80.5	4.4	77.7	1.8	1.9	-1049.8	155.8	0	02
2011-02-02-0600	2567.8	7	68.1	194.7	5.6	52.8	96.9	83.3	4.4	88.2	1.8	2.4	-1133.3	155	0	02
2011-02-02-0700	2924.8	8.1	74.6	226.9	5.4	58.2	102.9	89.2	4.3	112.3	1.9	3.4	-1207.1	154.8	0	02
2011-02-02-0800	3226	9	81.8	238.4	5.4	64.2	113.3	99.3	4.3	124.3	1.9	4.5	-1232.2	149.9	0	02
2011-02-02-0900	3300.9	9	84.2	232.4	6	62.8	119.2	103.1	4.3	126.6	1.9	4.6	-1250.3	142.5	0	02
2011-02-02-1000	3382	9.3	84.9	235.4	6.4	63	121.8	105.2	4.3	133.4	1.9	4.8	-1295.4	137.9	0	02
2011-02-02-1100	3356	9.1	85.9	238.8	6.8	63.9	123.4	106.3	4.3	134.6	1.9	4.8	-1275.6	137.7	0	02
2011-02-02-1200	3363.5	9.1	86.2	239.7	6.6	62.9	123.4	106.9	4.3	136.2	2	4.8	-1235.3	138.5	0	02
2011-02-02-1300	3378.4	9	85.4	236.6	6.5	62.3	123.5	106.1	4.3	141.1	2	4.7	-1315.8	137.3	0	02
2011-02-02-1400	3340.1	8.9	85.3	232.6	7.3	60.8	125.9	104.4	4.3	142.4	2	4.7	-1293.7	137.4	0	02
2011-02-02-1500	3329	8.8	84.5	230.2	6.9	60.1	127.1	103.6	4.3	141.5	2	4.6	-1289.9	137.4	0	02
2011-02-02-1600	3260.3	8.7	83.9	232.4	7.1	60.1	125.4	102.5	4.3	139.7	2	4.5	-1250.9	138.6	0	02
2011-02-02-1700	3267.5	8.6	84.2	273.5	7.4	61.6	110.9	100.9	4.3	142.4	1.9	4.4	-1376.6	138.8	0	02
2011-02-02-1800	3385	9	85	325.2	7.4	64.4	112.4	102.1	4.3	138.9	1.9	4.6	-1384.8	180.4	0	02
2011-02-02-1900	3495.9	9.4	86.9	325.3	6.7	68.5	119	106.7	4.3	143.5	1.9	4.9	-1408.1	233.8	0	02
2011-02-02-2000	3498	9.4	87.8	340	6.3	69.5	122.9	108.5	4.3	146.4	1.9	4.9	-1405.7	260.1	0	02

Exhibit No.  
Paul M. Normand  
Workpaper 3  
Page 16 of 17

LGE & KU - CORONA LOSS ESTIMATE

	VOLTAGE (kV)	MILES	CORONA PEAK LOSS FACTOR (MW Mile)	CORONA LOSSES (MW)	CORONA WINTER HOURS & LOSSES (MWH)	CORONA SUMMER HOURS & LOSSES (MWH)	CORONA TOTAL LOSSES (MWH)
A. Fair Weather Corona Losses							
	LGE						
1	345	172	0.0032	0.549	5,832	2,928	4,813
2	161	116	0.0000	0.000	3,204	1,609	0
3	138	334	0.0000	0.000	0	0	0
4	69	289	0.0000	0.000	0	0	0
5	Subtotal	911		0.549	3,204	1,609	4,813
	KU						
6	500	57	0.0060	0.341	5,832	2,928	2,989
7	345	395	0.0032	1.265	1,990	999	11,078
8	161	518	0.0000	0.000	7,375	3,703	0
9	138	888	0.0000	0.000	0	0	0
10	69	2,218	0.0000	0.000	0	0	0
11	Subtotal	4,076		1.606	9,365	4,702	14,067
12	TOTAL	4,987		2.155	12,569	6,311	18,880
B. Unmetered Station Use							
13	Estimated Unmetered Substation Use at			0.0010			

NOTE:  
(1) Lines 5 and 11 loss results included in Schedules 3, 4, and 5.

Exhibit No.  
Paul M. Normand  
Workpaper 3  
Page 17 of 17

**LGE & KU**

Voltage by Company	Number of Miles		
	LGE	KU	Total
1 <b>LGE</b>			
2 Overhead			
3 345	171.7		
4 161	116.4		
5 138	329.6		
6 69	286.3		
7 Total Overhead	904.0		904.0
8			
9 Underground			
10 138	4.0		
11 69	2.9		
12 Total Underground	6.9		6.9
13			
14 <b>Total LGE</b>	910.9		910.9
15			
16 <b>KU</b>			
17 500		56.9	
18 345		395.2	
19 161		518.2	
20 138		887.6	
21 69		2,218.4	
22			
23 <b>Total KU</b>		4,076.3	4,076.3
24			
25			
26 <b>Total Pole Miles</b>	910.9	4,076.3	4,987.2



**LG&E AND KU SERVICES COMPANY**  
**2010 Analysis of System Losses – LG&E Power System**

---

**Appendix B**

**Results of LG&E**  
**2010 Loss Analysis**



LG 2010 LOSS ANALYSIS

LG&E

EXHIBIT 1

SUMMARY OF COMPANY DATA

ANNUAL PEAK	2,852 MW
ANNUAL SYSTEM INPUT	12,966,029 MWH
ANNUAL SALES	12,399,868 MWH
SYSTEM LOSSES @ INPUT	566,161 or 4.37%
SYSTEM LOAD FACTOR	51.9%

SUMMARY OF LOSSES - OUTPUT RESULTS

SERVICE	KV	--- MW --- Input	% TOTAL	--- MWH --- Input	% TOTAL
TRANS	500,345,138 69	43.5	27.43%	132,516	23.41%
		1.53%		1.02%	
PRIM SUBS	33,12,1	16.2	10.21%	70,977	12.54%
		0.57%		0.55%	
PRIMARY	33,12,1	55.2	34.83%	160,720	28.39%
		1.94%		1.24%	
SECONDARY	120/240,to,477	43.7	27.54%	201,948	35.67%
		1.53%		1.56%	
TOTAL		158.6	100.00%	566,161	100.00%
		5.56%		4.37%	

SUMMARY OF LOSS FACTORS

SERVICE	KV	CUMMULATIVE SALES EXPANSION FACTORS			
		DEMAND (Peak)		ENERGY (Annual)	
		d	1/d	e	1/e
TOT TRANS	500,345,138 69	1.01549	0.98475	1.01033	0.98978
PRIM SUBS	33,12,1	1.02152	0.97894	1.01619	0.98407
PRIMARY	33,12,1	1.04295	0.95882	1.02998	0.97089
SECONDARY	120/240,to,477	1.06325	0.94052	1.05235	0.95025

LG 2010 LOSS ANALYSIS

SUMMARY OF CONDUCTOR INFORMATION

DESCRIPTION	CIRCUIT MILES	LOADING % RATING	MW LOSSES			TOTAL
			LOAD	NO LOAD		
--- BULK ----- 500 KV OR GREATER -----						
TIE LINES		0.0	0.00%	0.000	0.000	0.000
BULK TRANS		<u>0.0</u>	<u>0.00%</u>	<u>0.000</u>	<u>0.000</u>	<u>0.000</u>
SUBTOT		0.0		0.000	0.000	0.000
--- TRANS ----- 138 KV TO 500.00 KV -----						
TIE LINES		0	0.00%	0.000	0.000	0.000
TRANS1	345 KV	0.0	0.00%	0.000	0.000	0.000
TRANS2	<u>138 KV</u>	<u>0.0</u>	<u>0.00%</u>	<u>0.000</u>	<u>0.000</u>	<u>0.000</u>
SUBTOT		0.0		0.000	0.000	0.000
--- SUBTRANS ----- 35 KV TO 138 KV -----						
TIE LINES		0	0.00%	0.000	0.000	0.000
SUBTRANS1	KV	0.0	0.00%	0.000	0.000	0.000
SUBTRANS2	KV	0.0	0.00%	0.000	0.000	0.000
SUBTRANS3	<u>KV</u>	<u>0.0</u>	<u>0.00%</u>	<u>0.000</u>	<u>0.001</u>	<u>0.001</u>
SUBTOT		0.0		0.000	0.001	0.001
PRIMARY LINES		6,278		50.143	2.685	52.828
SECONDARY LINES		3,543		4.845	0.000	4.845
SERVICES		5,656		9.764	0.824	10.587
<b>TOTAL</b>		<b>15,477</b>		<b>64.752</b>	<b>3.509</b>	<b>68.261</b>

EXHIBIT 2

MW LOSSES		
LOAD	NO LOAD	TOTAL
0	0	0
<u>0</u>	<u>0</u>	<u>0</u>
0	0	0
-----		
0	0	0
<u>0</u>	<u>0</u>	<u>0</u>
0	0	0
-----		
0	0	0
<u>0</u>	<u>6</u>	<u>6</u>
0	6	6
-----		
129,898	23,520	153,418
-----		
8,557	0	8,557
-----		
26,554	7,214	33,768
-----		
165,009	30,739	195,748

LGE 2010 LOSS ANALYSIS

SUMMARY OF TRANSFORMER INFORMATION

EXHIBIT 3

DESCRIPTION	KV CAPACITY VOLTAGE	MVA	NUMBER TRANSFMR	AVERAGE SIZE	LOADING %	MVA LOAD	LOAD	MW LOSSES NO LOAD	TOTAL	LOAD	MWH LOSSES NO LOAD	TOTAL
BULK STEP-UP	500	0.0	0	0.0	0.00%	0	0.000	0.000	0.000	0	0	0
BULK - BULK		0.0	0	0.0	0.00%	0	0.000	0.000	0.000	0	0	0
BULK - TRANS1	345	0.0	0	0.0	0.00%	0	0.000	0.000	0.000	0	0	0
BULK - TRANS2	138	0.0	0	0.0	0.00%	0	0.000	0.000	0.000	0	0	0
TRANS1 STEP-UP	345	0.0	0	0.0	0.00%	0	0.000	0.000	0.000	0	0	0
TRANS1 - TRANS2	138	0.0	0	0.0	0.00%	0	0.000	0.000	0.000	0	0	0
TRANS1-SUBTRANS1	69	0.0	0	0.0	0.00%	0	0.000	0.000	0.000	0	0	0
TRANS1-SUBTRANS2	66	0.0	0	0.0	0.00%	0	0.000	0.000	0.000	0	0	0
TRANS1-SUBTRANS3	35	0.0	0	0.0	0.00%	0	0.000	0.000	0.000	0	0	0
TRANS2 STEP-UP	138	0.0	0	0.0	0.00%	0	0.000	0.000	0.000	0	0	0
TRANS2-SUBTRANS1	69	0.0	0	0.0	0.00%	0	0.000	0.000	0.000	0	0	0
TRANS2-SUBTRANS2	66	0.0	0	0.0	0.00%	0	0.000	0.000	0.000	0	0	0
TRANS2-SUBTRANS3	35	0.0	0	0.0	0.00%	0	0.000	0.000	0.000	0	0	0
SUBTRAN1 STEP-UP	69	0.0	0	0.0	0.00%	0	0.000	0.000	0.000	0	0	0
SUBTRAN2 STEP-UP	66	0.0	0	0.0	0.00%	0	0.000	0.000	0.000	0	0	0
SUBTRAN3 STEP-UP	35	0.0	0	0.0	0.00%	0	0.000	0.000	0.000	0	0	0
SUBTRAN1-SUBTRAN2	66	0.0	0	0.0	0.00%	0	0.000	0.000	0.000	0	0	0
SUBTRAN1-SUBTRAN3	35	0.0	0	0.0	0.00%	0	0.000	0.000	0.000	0	0	0
SUBTRAN2-SUBTRAN3	35	0.0	0	0.0	0.00%	0	0.000	0.000	0.000	0	0	0
DISTRIBUTION SUBSTATIONS												
TRANS1 -	345	33	0.0	0	0.0	0.00%	0	0.000	0.000	0	0	0
TRANS1 -	345	12	0.0	0	0.0	0.00%	0	0.000	0.000	0	0	0
TRANS1 -	345	1	0.0	0	0.0	0.00%	0	0.000	0.000	0	0	0
TRANS2 -	138	33	115.5	4	28.9	60.99%	70	0.209	0.205	503	1,501	2,004
TRANS2 -	138	12	1,464.0	50	29.3	80.26%	1,175	3.771	2,805	6,576	9,059	19,624
TRANS2 -	138	1	0.0	0	0.0	0.00%	0	0.000	0.000	0	0	0
SUBTRAN1-	69	33	0.0	0	0.0	0.00%	0	0.000	0.000	0	0	0
SUBTRAN1-	69	12	1,817.3	81	22.4	89.16%	1,620	5.000	3,745	8,745	12,012	25,976
SUBTRAN1-	69	1	0.0	0	0.0	0.00%	0	0.000	0.000	0	0	0
SUBTRAN2-	66	33	0.0	0	0.0	0.00%	0	0.000	0.000	0	0	0
SUBTRAN2-	66	12	0.0	0	0.0	0.00%	0	0.000	0.000	0	0	0
SUBTRAN2-	66	1	0.0	0	0.0	0.00%	0	0.000	0.000	0	0	0
SUBTRAN3-	35	33	0.0	0	0.0	0.00%	0	0.000	0.000	0	0	0
SUBTRAN3-	35	12	0.0	0	0.0	0.00%	0	0.000	0.000	0	0	0
SUBTRAN3-	35	1	0.0	0	0.0	0.00%	0	0.000	0.000	0	0	0
PRIMARY - PRIMARY		172.7	38	4.5	86.05%	149	0.870	0.307	1.177	2,090	2,687	4,777
LINE TRANSFRMR		5,499.8	86,403	63.7	45.60%	2,508	12.631	14.398	27.028	26,952	126,123	153,074
TOTAL		9,069	86,576				22,481	21,460	43,941	50,615	175,911	226,527

LGE 2010 LOSS ANALYSIS

SUMMARY OF LOSSES DIAGRAM - DEMAND MODEL - SYSTEM PEAK

2852 MW

EXHIBIT 4 PAGE 1 of 2

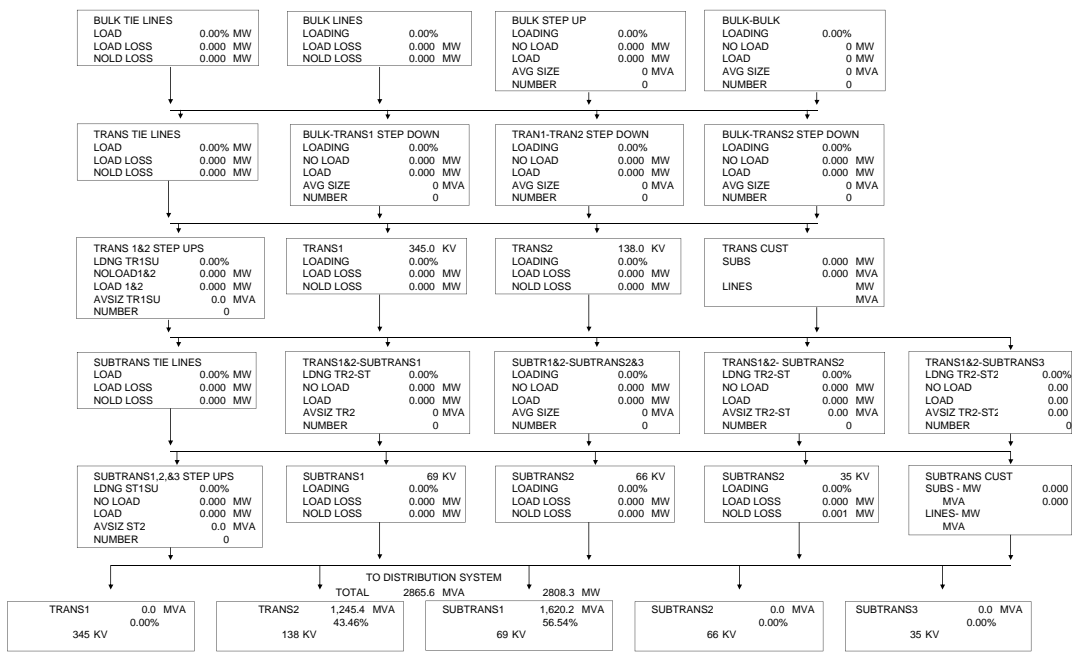

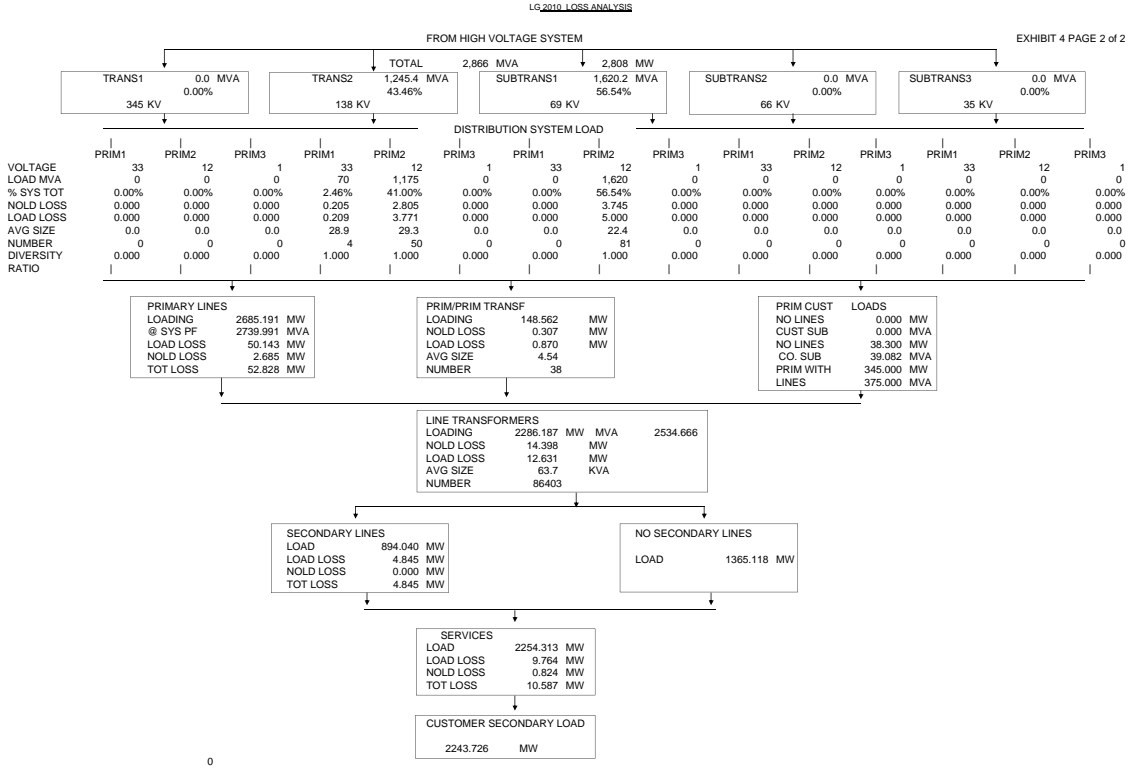

LG 2010 LOSS ANALYSIS

**SUMMARY of SALES and CALCULATED LOSSES**

EXHIBIT 5

LOSS # AND LEVEL	MW LOAD	NO LOAD	+	LOAD	=	TOT LOSS	EXP FACTOR	CUM EXP FAC	MWH LOAD	NO LOAD	+	LOAD	=	TOT LOSS	EXP FACTOR	CUM EXP FAC
1 BULK XFMMR	0.0	0.00		0.00		0.00	0.000000	0.000000	0	0		0		0	0	0
2 BULK LINES	0.0	0.00		0.00		0.00	0.000000	0.000000	0	0		0		0	0.000000	0.000000
3 TRANS1 XFMR	0.0	0.00		0.00		0.00	0.000000	0.000000	0	0		0		0	0.000000	0.000000
4 TRANS1 LINES	0.0	0.00		0.00		0.00	0.000000	0.000000	0	0		0		0	0.000000	0.000000
5 TRANS2TR1 SD	0.0	0.00		0.00		0.00	0.000000	0.000000	0	0		0		0	0.000000	0.000000
6 TRANS GSU	0.0	0.00		0.00		0.00	0.000000	0.000000	0	0		0		0	0.000000	0.000000
7 TRANS2 LINES	0.0	4.43		39.07		43.50	0.000000	0.000000	0	29,013		103,503		132,516	0.000000	0.000000
TOTAL TRAN	2,852.0	4.43		39.07		43.50	1.015489	1.015489	12,966,029	29013		103503		132,516	1.0103258	1.0103258
8 STR1BLK SD																
9 STR1T1 SD	0.0	0.00		0.00		0.00	0.000000	0.000000	0	0		0		0	0.000000	0.000000
10 SRT1T2 SD	0.0	0.00		0.00		0.00	0.000000	0.000000	0	0		0		0	0.000000	0.000000
11 SUBTRANS1 LINES	0.0	0.00		0.00		0.00	0.000000	0.000000	0	0		0		0	0.000000	0.000000
12 STR2T1 SD	0.0	0.00		0.00		0.00	0.000000	0.000000	0	0		0		0	0.000000	0.000000
13 STR2T2 SD	0.0	0.00		0.00		0.00	0.000000	0.000000	0	0		0		0	0.000000	0.000000
14 STR2S1 SD	0.0	0.00		0.00		0.00	0.000000	0.000000	0	0		0		0	0.000000	0.000000
15 SUBTRANS2 LINES	0.0	0.00		0.00		0.00	0.000000	0.000000	0	0		0		0	0.000000	0.000000
16 STR3T1 SD	0.0	0.00		0.00		0.00	0.000000	0.000000	0	0		0		0	0.000000	0.000000
17 STR3T2 SD	0.0	0.00		0.00		0.00	0.000000	0.000000	0	0		0		0	0.000000	0.000000
18 STR3S1 SD	0.0	0.00		0.00		0.00	0.000000	0.000000	0	0		0		0	0.000000	0.000000
19 STR3S2 SD	0.0	0.00		0.00		0.00	0.000000	0.000000	0	0		0		0	0.000000	0.000000
20 SUBTRANS3 LINES	0.0	0.00		0.00		0.00	0.000000	0.000000	0	6		0		6	0.000000	0.000000
21 SUBTRANS TOTAL	0.0	0.00		0.00		0.00	0.000000	0.000000	0	6		0		6	0.000000	0.000000
<b>22 TOT TRANS LOSS FAC</b>	<b>2,852.0</b>	<b>4.43</b>		<b>39.07</b>		<b>43.50</b>	<b>1.015489</b>	<b>1.015489</b>	<b>12,966,029</b>	<b>29,013</b>		<b>103,503</b>		<b>132,516</b>	<b>1.010326</b>	<b>1.0103258</b>
DISTRIBUTION SUBST																
TRANS1	0.0	0.00		0.00		0.00	0.000000	0.000000	0	0		0		0	0.000000	0.000000
TRANS2	1,151.5	3.01		3.98		6.99	1.006108	0.000000	5,338,276	21,126		9,562		30,687	1.0057818	0.000000
SUBTR1	1,587.8	3.74		5.00		8.74	1.005538	0.000000	6,944,729	25,976		12,012		37,988	1.0055001	0.000000
SUBTR2	0.0	0.00		0.00		0.00	0.000000	0.000000	0	0		0		0	0.000000	0.000000
SUBTR3	0.0	0.00		0.00		0.00	0.000000	0.000000	0	0		0		0	0.000000	0.000000
WEIGHTED AVERAGE	2,739.2	6.76		8.98		15.74	1.005778	1.021356	12,283,005	47,102		21,574		68,675	1.0056225	1.0160063
PRIMARY INTRCHNGE	0.0						0.000000		0					0	0.000000	
PRIMARY LINES	2,684.9	2.68		51.01		53.70	1.020408	1.042200	11,989,742	23,520		131,988		155,508	1.0131405	1.0293572
LINE TRANSF	2,286.2	14.40		12.63		27.03	1.011964	1.054669	9,493,517	126,123		26,952		153,074	1.0163883	1.0462266
SECONDARY	2,259.2	0.00		4.84		4.84	1.002149	1.056935	9,340,443	0		8,557		8,557	1.0009169	1.0471860
SERVICES	2,254.3	0.82		9.76		10.59	1.004719	1.061923	9,331,886	7,214		26,554		33,768	1.0036317	1.0509890
=====																
TOTAL SYSTEM		29.09		126.30		155.39				232,971		319,127		552,098		

LG 2010 LOSS ANALYSIS

**DEVELOPMENT of LOSS FACTORS  
UNADJUSTED  
DEMAND**

EXHIBIT 6

LOSS FACTOR LEVEL	CUSTOMER SALES MW	CALC LOSS TO LEVEL	SALES MW @ GEN	CUM PEAK EXPANSION FACTORS	
	a	b	c	d	1/d
BULK LINES	0.0	0.0	0.0	0.00000	0.00000
TRANS SUBS	0.0	0.0	0.0	0.00000	0.00000
TRANS LINES	0.0	0.0	0.0	0.00000	0.00000
SUBTRANS SUBS	0.0	0.0	0.0	0.00000	0.00000
TOTAL TRANS	66.4	1.0	67.4	1.01549	0.98475
PRIM SUBS	38.3	0.8	39.1	1.02136	0.97909
PRIM LINES	345.0	14.6	359.6	1.04220	0.95951
SECONDARY	<u>2,243.7</u>	<u>138.9</u>	<u>2,382.7</u>	1.06192	0.94169
TOTALS	2,693.4	155.3	2,848.8		

**DEVELOPMENT of LOSS FACTORS  
UNADJUSTED  
ENERGY**

LOSS FACTOR LEVEL	CUSTOMER SALES MWH	CALC LOSS TO LEVEL	SALES MWH @ GEN	CUM ANNUAL EXPANSION FACTORS	
	a	b	c	d	1/d
BULK LINES	0	0	0	0.00000	0.00000
TRANS SUBS	0	0	0	0.00000	0.00000
TRANS LINES	0	0	0	0.00000	0.00000
SUBTRANS SUBS	0	0	0	0.00000	0.00000
TOTAL TRANS	536,042	5,535	541,577	1.01033	0.98978
PRIM SUBS	224,991	3,601	228,592	1.01601	0.98425
PRIM LINES	2,340,717	68,717	2,409,434	1.02936	0.97148
SECONDARY	<u>9,298,118</u>	<u>474,102</u>	<u>9,772,220</u>	1.05099	0.95148
TOTALS	12,399,868	551,955	12,951,823		

ESTIMATED VALUES AT GENERATION

LOSS FACTOR AT VOLTAGE LEVEL	MW	MWH
BULK LINES	0.00	0
TRANS SUBS	0.00	0
TRANS LINES	0.00	0
SUBTRANS SUBS	0.00	0
SUBTRANS LINES	67.43	541,577
PRIM SUBS	39.12	228,592
PRIM LINES	359.56	2,409,434
SECONDARY	2,382.66	9,772,220
SUBTOTAL	2,848.77	12,951,823
ACTUAL ENERGY	2,852.00	12,966,029
MISSMATCH	(3.23)	(14,206)
% MISSMATCH	-0.11%	-0.11%



LG 2010 LOSS ANALYSIS

**DEVELOPMENT of LOSS FACTORS  
ADJUSTED  
DEMAND**

EXHIBIT 7

LOSS FACTOR LEVEL	CUSTOMER SALES MW a	SALES ADJUST b	CALC LOSS TO LEVEL c	SALES MW @ GEN d	CUM PEAK EXPANSION FACTORS e	f=1/e
BULK LINES	0.0	0.0	0.0	0.0	0.00000	0.00000
TRANS SUBS	0.0	0.0	0.0	0.0	0.00000	0.00000
TRANS LINES	0.0	0.0	0.0	0.0	0.00000	0.00000
SUBTRANS SUBS	0.0	0.0	0.0	0.0	0.00000	0.00000
TOTAL TRANS	66.4	0.0	1.0	67.4	1.01549	0.98475
PRIM SUBS	38.3	0.0	0.8	39.1	1.02152	0.97894
PRIM LINES	345.0	0.0	14.8	359.8	1.04295	0.95882
SECONDARY	<u>2,243.7</u>	<u>0.0</u>	141.9	<u>2,385.6</u>	1.06325	0.94052
TOTALS	2,693.4	0.0	158.6	2,852.0		

**DEVELOPMENT of LOSS FACTORS  
ADJUSTED  
ENERGY**

LOSS FACTOR LEVEL	CUSTOMER SALES MWH a	SALES ADJUST b	CALC LOSS TO LEVEL c	SALES MWH @ GEN d	CUM ANNUAL EXPANSION FACTORS e	f=1/e
BULK LINES	0	0	0	0	0.00000	0.00000
TRANS SUBS	0	0	0	0	0.00000	0.00000
TRANS LINES	0	0	0	0	0.00000	0.00000
SUBTRANS SUBS	0	0	0	0	0.00000	0.00000
TOTAL TRANS	536,042	0	5,535	541,577	1.01033	0.98978
PRIM SUBS	224,991	0	3,643	228,634	1.01619	0.98407
PRIM LINES	2,340,717	0	70,184	2,410,901	1.02998	0.97089
SECONDARY	<u>9,298,118</u>	<u>0</u>	486,797	<u>9,784,915</u>	1.05235	0.95025
TOTALS	12,399,868	0	566,161	12,966,027		

ESTIMATED VALUES AT GENERATION

LOSS FACTOR AT VOLTAGE LEVEL	MW	MWH
BULK LINES	0.00	0
TRANS SUBS	0.00	0
TRANS LINES	0.00	0
SUBTRANS SUBS	0.00	0
SUBTRANS LINES	67.43	541,577
PRIM SUBS	39.12	228,634
PRIM LINES	359.82	2,410,901
SECONDARY	<u>2,385.63</u>	<u>9,784,915</u>
	2,852.00	12,966,027
ACTUAL ENERGY	2,852.00	12,966,029
MISSMATCH	0.00	(2)
% MISSMATCH	0.00%	0.00%

LGE 2010 LOSS ANALYSIS

Adjusted Losses and Loss Factors by Facility

EXHIBIT 8

Unadjusted Losses by Segment				
	MW	Unadjusted	MWH	Unadjusted
Service Drop Losses	10.59	10.58	33,768	33,756
Secondary Losses	4.84	4.84	8,557	8,554
Line Transformer Losses	27.03	27.02	153,074	153,022
Primary Line Losses	53.70	53.67	155,508	155,455
Distribution Substation Losses	15.74	15.73	68,675	68,652
<u>Transmission System Losses</u>	<u>43.50</u>	<u>43.50</u>	<u>132,516</u>	<u>132,516</u>
<b>Total</b>	<b>155.39</b>	<b>155.34</b>	<b>552,098</b>	<b>551,955</b>

Mismatch Allocation by Segment		
	MW	MWH
Service Drop Losses	-0.31	-1,143
Secondary Losses	-0.14	-290
Line Transformer Losses	-0.78	-5,183
Primary Line Losses	-1.55	-5,265
Distribution Substation Losses	-0.45	-2,325
<u>Transmission System Losses</u>	<u>0.00</u>	<u>0</u>
<b>Total</b>	<b>-3.23</b>	<b>-14,206</b>

Adjusted Losses by Segment				
	MW	% of Total	MWH	% of Total
Service Drop Losses	10.89	6.9%	34,899	6.2%
Secondary Losses	4.98	3.1%	8,844	1.6%
Line Transformer Losses	27.80	17.5%	158,205	27.9%
Primary Line Losses	55.22	34.8%	160,720	28.4%
Distribution Substation Losses	16.18	10.2%	70,977	12.5%
<u>Transmission System Losses</u>	<u>43.50</u>	<u>27.4%</u>	<u>132,516</u>	<u>23.4%</u>
<b>Total</b>	<b>158.57</b>	<b>100.0%</b>	<b>566,161</b>	<b>100.0%</b>

Loss Factors by Segment			
	MW	MWH	
Retail Sales from Service Drops	2,243,726	9,298,118	
<u>Adjusted Service Drop Losses</u>	<u>10,888</u>	<u>34,899</u>	
Input to Service Drops	2,254,614	9,333,017	
<b>Service Drop Loss Factor</b>	<b>1.00485</b>	<b>1.00375</b>	
Output from Secondary	2,254,614	9,333,017	
<u>Adjusted Secondary Losses</u>	<u>4,983</u>	<u>8,844</u>	
Input to Secondary	2,259,597	9,341,861	
<b>Secondary Conductor Loss Factor</b>	<b>1.00221</b>	<b>1.00095</b>	
Output from Line Transformers	2,259,597	9,341,861	
<u>Adjusted Line Transformer Losses</u>	<u>27,796</u>	<u>158,205</u>	
Input to Line Transformers	2,287,393	9,500,066	
<b>Line Transformer Loss Factor</b>	<b>1.01230</b>	<b>1.01694</b>	
Retail Sales from Primary	345,000	2,340,717	
Req. Whls Sales from Primary	0.000	0	
<u>Input to Line Transformers</u>	<u>2,287,393</u>	<u>9,500,066</u>	
Output from Primary Lines	2,632,393	11,840,783	
<u>Adjusted Primary Line Losses</u>	<u>55,224</u>	<u>160,720</u>	
Input to Primary Lines	2,687,617	12,001,503	
<b>Primary Line Loss Factor</b>	<b>1.02098</b>	<b>1.01357</b>	
Output PI from Distribution Substations	2,687,617	12,001,503	
Req. Whls Sales from Substations	0.000	0	
Retail Sales from Substations	38,300	224,991	
<u>Total Output from Distribution Substations</u>	<u>2,725,917</u>	<u>12,226,494</u>	
<u>Adjusted Distribution Substation Losses</u>	<u>16,183</u>	<u>70,977</u>	
Input to Distribution Substations	2,742,100	12,297,471	
<b>Distribution Substation Loss Factor</b>	<b>1.00594</b>	<b>1.00581</b>	
Retail Sales at from SubTransmission	66,400	536,042	
Req. Whls Sales from SubTransmission	0.000	0	
Non-Req. Whls Sales from SubTransmission	0.000	0	
Losses	0.000	0	
<u>Input to Distribution Substations</u>	<u>2,742,100</u>	<u>12,297,471</u>	
Output from SubTransmission	2,808,500	12,833,513	
<u>SubTransmission System Losses</u>	<u>43,500</u>	<u>132,516</u>	
Input to Transmission	2,852,000	12,966,029	
<b>TotTransmission System Loss Factor</b>	<b>1.01549</b>	<b>1.01033</b>	<b>43.500</b>

DEMAND MW		SUMMARY OF LOSSES AND LOSS FACTORS BY DELIVERY VOLTAGE						EXHIBIT 9
SERVICE LEVEL		SALES MW	LOSSES	SECONDARY	PRIMARY	SUBSTATION	SUBTRANS	TRANSMISSION
1	<b>SERVICES</b>							
2	SALES	2,243.7						
3	LOSSES		10.9					
4	INPUT				2,254.6			
5	<b>EXPANSION FACTOR</b>	<b>1.00485</b>						
6	<b>SECONDARY</b>							
7	SALES							
8	LOSSES		5.0		5.0			
9	INPUT				2,259.6			
10	<b>EXPANSION FACTOR</b>	<b>1.00221</b>						
11	<b>LINE TRANSFORMER</b>							
12	SALES							
13	LOSSES		27.8		27.8			
14	INPUT				2,287.4			
15	<b>EXPANSION FACTOR</b>	<b>1.01230</b>						
16	<b>PRIMARY</b>							
17	SECONDARY			2,287.4				
18	SALES	345.0			345.0			
19	LOSSES		55.2	48.0	7.2			
20	INPUT			2,335.4	352.2			
21	<b>EXPANSION FACTOR</b>	<b>1.02098</b>						
22	<b>SUBSTATION</b>							
23	PRIMARY			2,335.4	352.2			
24	SALES	38.3				38.3		
25	LOSSES		16.2	13.9	2.1	0.2		
26	INPUT			2,349.2	354.3	38.5		
27	<b>EXPANSION FACTOR</b>	<b>1.00594</b>						
28	<b>SUB-TRANSMISSION</b>							
29	DISTRIBUTION SUBS							
30	SALES							
31	LOSSES							
32	INPUT							
33	<b>EXPANSION FACTOR</b>							
34	<b>TRANSMISSION</b>							
35	SUBTRANSMISSION							
36	DISTRIBUTION SUBS			2,349.2	354.3	38.5		
37	SALES	66.4						66.4
38	LOSSES		43.5	36.4	5.5	0.6		1.0
39	INPUT			2,385.6	359.8	39.1		67.4
40	<b>EXPANSION FACTOR</b>	<b>1.01549</b>						
41	<b>TOTALS</b>							
42	LOSSES		158.6	141.9	14.8	0.8		1.0
42	% OF TOTAL		100%	89.49%	9.34%	0.52%		0.65%
43	SALES	2,693.4		2,243.7	345.0	38.3		66.4
44	% OF TOTAL	100.00%		83.30%	12.81%	1.42%		2.47%
45	INPUT	2,852.0		2,385.6	359.8	39.1		67.4
46	<b>CUMMULATIVE EXPANSION LOSS FACTORS</b>			<b>1.06325</b>	<b>1.04295</b>	<b>1.02152</b>		<b>1.01549</b>
	(from meter to system input)							

ENERGY MWH		SUMMARY OF LOSSES AND LOSS FACTORS BY DELIVERY VOLTAGE						EXHIBIT 9
SERVICE LEVEL		SALES	LOSSES	SECONDARY	PRIMARY	SUBSTATION	SUBTRANS	TRANSMISSION
1	<b>SERVICES</b>							
2	SALES	9,298,118			9,298,118			
3	LOSSES		34,899		34,899			
4	INPUT				9,333,017			
5	<b>EXPANSION FACTOR</b>	<b>1.00375</b>						
6	<b>SECONDARY</b>							
7	SALES							
8	LOSSES		8,844		8,844			
9	INPUT				9,341,861			
10	<b>EXPANSION FACTOR</b>	<b>1.00095</b>						
11	<b>LINE TRANSFORMER</b>							
12	SALES							
13	LOSSES		158,205		158,205			
14	INPUT				9,500,066			
15	<b>EXPANSION FACTOR</b>	<b>1.01694</b>						
16	<b>PRIMARY</b>							
17	SECONDARY				9,500,066			
18	SALES	2,340,717.000			2,340,717			
19	LOSSES		160,720		128,948		31,772	
20	INPUT				9,629,014		2,372,489	
21	<b>EXPANSION FACTOR</b>	<b>1.01357</b>						
22	<b>SUBSTATION</b>							
23	PRIMARY				9,629,014	2,372,489		
24	SALES	224,991					224,991	
25	LOSSES		70,977		55,898	13,773	1,306	
26	INPUT				9,684,912	2,386,261	226,297	
27	<b>EXPANSION FACTOR</b>	<b>1.00581</b>						
28	<b>SUB-TRANSMISSION</b>							
29	DISTRIBUTION SUBS							
30	SALES							
31	LOSSES							
32	INPUT							
33	<b>EXPANSION FACTOR</b>							
34	<b>TRANSMISSION</b>							
35	SUBTRANSMISSION							
36	DISTRIBUTION SUBS				9,684,912	2,386,261	226,297	
37	SALES	536,042						536,042
38	LOSSES		132,516		100,004	24,640	2,337	5,535
39	INPUT				9,784,917	2,410,901	228,634	541,577
40	<b>EXPANSION FACTOR</b>	<b>1.01033</b>						
41	<b>TOTALS</b>							
42	LOSSES		566,161		486,799	70,184	3,643	5,535
42	% OF TOTAL		100%		85.98%	12.40%	0.64%	0.98%
43	SALES	12,399,868			9,298,118	2,340,717	224,991	536,042
44	% OF TOTAL	100.00%			74.99%	18.88%	1.81%	4.32%
45	INPUT	12,966,029			9,784,917	2,410,901	228,634	541,577
46	<b>CUMMULATIVE EXPANSION LOSS FACTORS</b>				<b>1.05235</b>	<b>1.02998</b>	<b>1.01619</b>	<b>1.01033</b>
	(from meter to system input)							

LG&E AND KU SERVICES COMPANY  
2010 Analysis of System Losses – LG&E Power System

---

## Appendix C

### Discussion of Hoebel Coefficient



**COMMENTS ON THE HOEBEL COEFFICIENT**

The Hoebel coefficient represents an established industry standard relationship between peak losses and average losses and is used in a loss study to estimate energy losses from peak demand losses. H. F. Hoebel described this relationship in his article, "Cost of Electric Distribution Losses," Electric Light and Power, March 15, 1959. A copy of this article is attached.

Within any loss evaluation study, peak demand losses can readily be calculated given equipment resistance and approximate loading. Energy losses, however, are much more difficult to determine given their time-varying nature. This difficulty can be reduced by the use of an equation which relates peak load losses (demand) to average losses (energy). Once the relationship between peak and average losses is known, average losses can be estimated from the known peak load losses.

Within the electric utility industry, the relationship between peak and average losses is known as the loss factor. For definitional purposes, loss factor is the ratio of the average power loss to the peak load power loss, during a specified period of time. This relationship is expressed mathematically as follows:

$$\frac{(1) \text{ } F_{LS} \cdot A_{LS}}{P_{LS}}$$

where:  $F_{LS}$  = Loss Factor  
 $A_{LS}$  = Average Losses  
 $P_{LS}$  = Peak Losses

The loss factor provides an estimate of the degree to which the load loss is maintained throughout the period in which the loss is being considered. In other words, loss factor is the ratio of the actual kWh losses incurred to the kWh losses which would have occurred if full load had continued throughout the period under study.

Examining the loss factor expression in light of a similar expression for load factor indicates a high degree of similarity. The mathematical expression for load factor is as follows:

$$\frac{(2) \text{ } F_{LD} \cdot A_{LD}}{P_{LD}}$$

where:  $F_{LD}$  = Load Factor  
 $A_{LD}$  = Average Load  
 $P_{LD}$  = Peak Load

This load factor result provides an estimate of the degree to which the load loss is maintained throughout the period in which the load is being considered. Because of the similarities in definition, the loss factor is sometimes called the "load factor of losses." While the definitions are similar, a strict equating of the two factors cannot be made. There does exist, however, a relationship between these two factors which is dependent upon the shape of the load duration curve. Since resistive losses vary as the square of the load, it can be shown mathematically that the loss factor can vary between the extreme limits of load factor and load factor squared. The relationship between load factor and loss factor has become an industry standard and is as follows:

$$(3) \ F_{LS} = H \cdot F_{LD}^2 + (1-H) \cdot F_{LD}$$

where:  $F_{LS}$  = Loss Factor  
 $F_{LD}$  = Load Factor  
 $H$  = Hoebel Coeff

As noted in the attached article, the suggested value for H (the Hoebel coefficient) is 0.7. The exact value of H will vary as a function of the shape of the utility's load duration curve. In recent years, values of H have been computed directly for a number of utilities based on EEI load data. It appears on this basis, the suggested value of 0.7 should be considered a lower bound and that values approaching unity may be considered a reasonable upper bound. Based on experience, values of H have ranged from approximately 0.85 to 0.95. The standard default value of 0.9 is generally used.

Inserting the Hoebel coefficient estimate gives the following loss factor relationship using Equation (3):

$$(4) \ F_{LS} = 0.90 \cdot F_{LD}^2 + 0.10 \cdot F_{LD}$$

Once the Hoebel constant has been estimated and the load factor and peak losses associated with a piece of equipment have been estimated, one can calculate the average, or energy losses as follows:

$$(5) \ A_{LS} = P_{LS} \cdot [H \cdot F_{LD}^2 + (1-H) \cdot F_{LD}]$$

where:  $A_{LS}$  = Average Losses  
 $P_{LS}$  = Peak Losses  
 $H$  = Hoebel Coefficient  
 $F_{LD}$  = Load Factor

Loss studies use this equation to calculate energy losses at each major voltage level in the analysis.