

UNBRIDLED SOLAR PROJECT

HENDERSON & WEBSTER COUNTY KENTUCKY

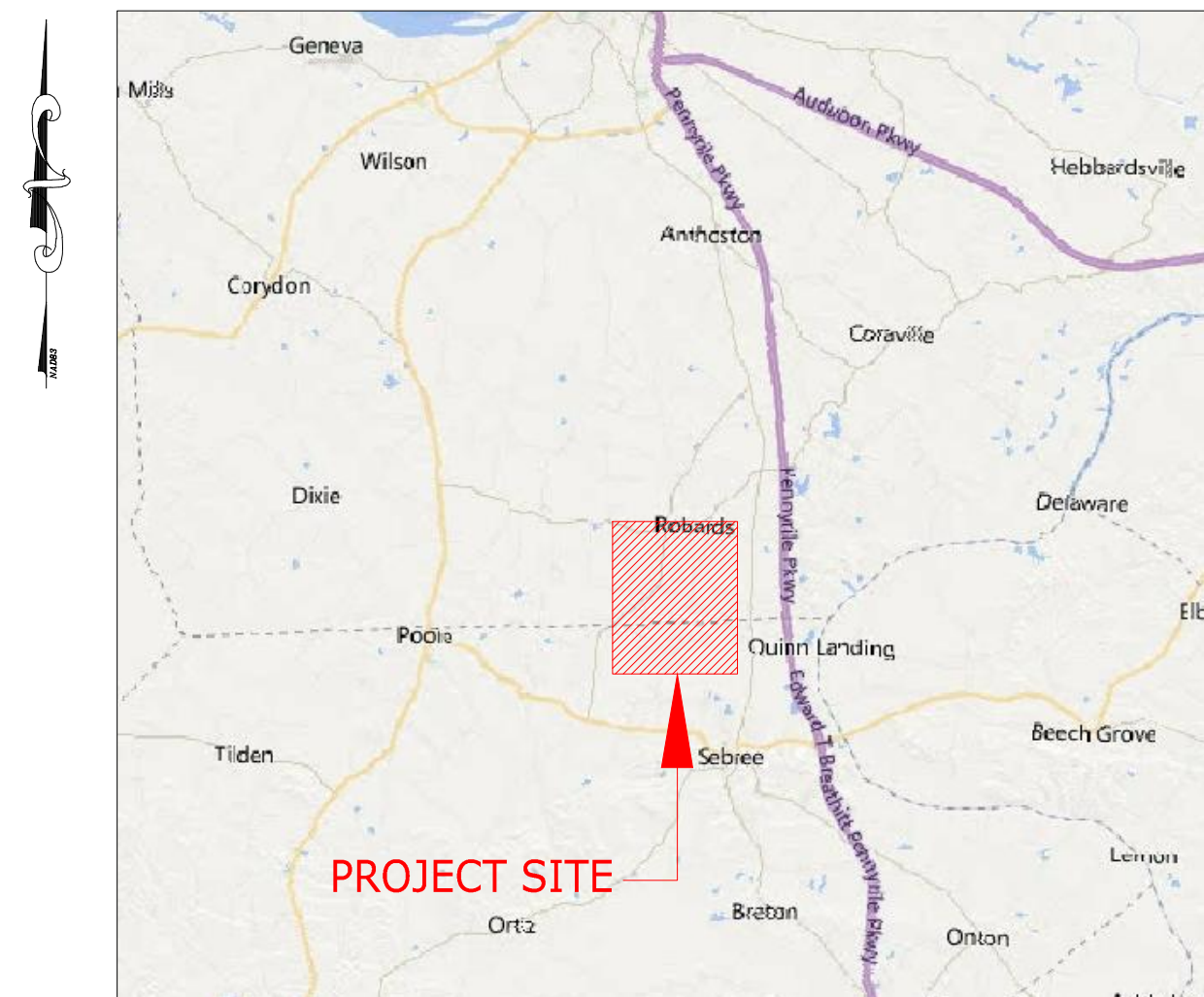

VICINITY MAP

Sheet List Table	
Sheet Number	Sheet Title
UNB-E-000-01	COVER SHEET
UNB-T-100-01	OVERALL TRANSMISSION LINE ROUTE MAP
UNB-E-500-03	OVERALL SITE ARRAY PLAN
UNB-E-502-01	KEYMAP LAYOUT TOP
UNB-E-502-02	KEYMAP LAYOUT CENTER
UNB-E-502-03	KEYMAP LAYOUT BOTTOM
UNB-E-522-03	TYPICAL OVERHEAD COLLECTOR LINE DETAILS
UNB-L-900-01	VEGETATION SCREENING NOTES AND DETAILS



OWNER:
NATIONALGRID RENEWABLES
8400 NORMANDE LAKE BLVD. SUITE 1200
BLOOMINGTON, MN 55437



ENGINEER:
TIMMONS GROUP
971 NORTH GILBERT ROAD, SUITE 204
GILBERT, AZ 85234
TELEPHONE: (480) 386-8058
WWW.TIMMONS.COM



PROJECT NAME & ADDRESS
UNBRIDLED SOLAR
HENDERSON & WEBSTER COUNTY
KENTUCKY

DATE: 12/03/2020
PROJECT NUMBER: 46670
DRAWN BY: R. SIERRA
DESIGNED BY: S. UPADHYAY

SEAL
PRELIMINARY
NOT FOR CONSTRUCTION

REVISIONS	
#	DESCRIPTION
A	10/20/20 ISSUED FOR REVIEW
B	10/26/20 ISSUED FOR REVIEW
C	11/03/20 ISSUED FOR REVIEW
D	12/02/20 ISSUED FOR REVIEW
E	

DRAWING DESCRIPTION
COVER SHEET
34"x22" FULL SIZE
(17"x11" PLOTS ARE HALF SCALE)

SCALE	SHEET NUMBER
N.T.S.	UNB-E-000-01

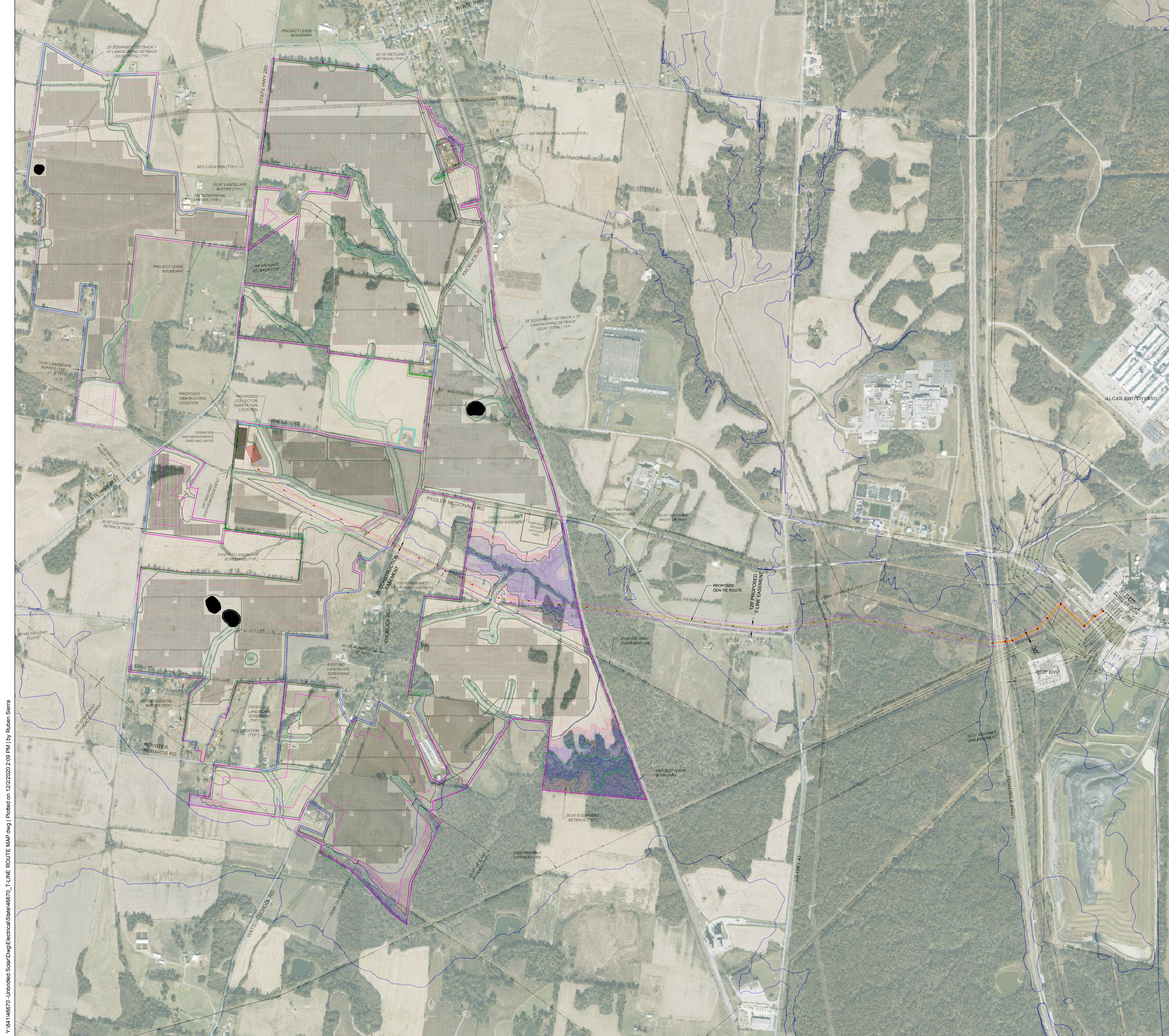

Y:\94146670_UBRIDLED Solar\DWG\Electrical\State\46670_T-LINE_ROUTE_MAP.dwg | Plotted on 12/22/2020 2:09 PM | by Ruben Sierra

- LEGEND:**
- PROJECT BOUNDARY (SUPPLIED KMZ)
 - EQUIPMENT SETBACK (SOLAR ORDINANCE)
 - 200' INVERTER SETBACK (ASSUMED 500BA)
 - WETLAND BOUNDARY (DELINEATION DATA)
 - 40' WETLAND SETBACK (KDOT)
 - 100-YEAR FLOOD BOUNDARY (FEMA NFHL VIEWER)
 - EXISTING ROADS (PUBLIC DATA)
 - 69KV T-OHU — 69KV OVERHEAD LINE (BIG RIVER GIS)
 - 161KV T-OHU — 161KV OVERHEAD LINE (BIG RIVER GIS)
 - 345KV T-OHU — 345KV OVERHEAD LINE (BIG RIVER GIS)
 - T-OHU — FOREIGN OVERHEAD LINE (BIG RIVER GIS)
 - UTILITY EASEMENT (ASSUMED)
 - 100' RESIDENTIAL BUFFER (HENDERSON COUNTY SOLAR ORDINANCE)
 - EXISTING UTILITY POLE (SUPPLIED KMZ)
 - 2 FLOW DEPTH (FLO-2D MODEL BY OTHERS)
 - 4 FLOW DEPTH (FLO-2D MODEL BY OTHERS)
 - 6 FLOW DEPTH (FLO-2D MODEL BY OTHERS)
 - LANDSCAPE SCREENING EXISTING
 - LANDSCAPE SCREENING
 - PROPOSED SUBSTATION LOCATION
 - PROPOSED O&M BUILDING & MAINTENANCE YARD & OFFICE
 - PROPOSED OPERATION & MAINTENANCE YARD & OFFICE
 - PROPOSED SITE FENCE
 - PROPOSED SITE ROAD
 - PROPOSED T-LINE EASEMENT
 - PROPOSED T-LINE
 - PROPOSED T-LINE POLE
- PV PANEL TRACKER

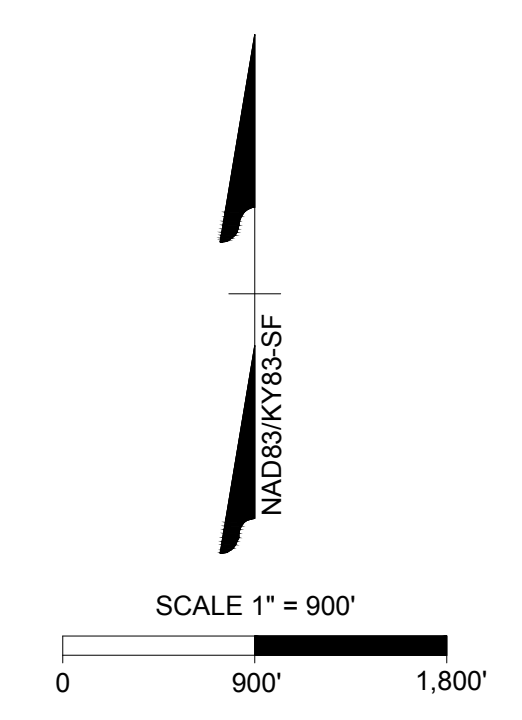

TIMMONS GROUP
 YOUR VISION ACHIEVED THROUGH OURS.
 THIS DRAWING PREPARED AT THE
GILBERT OFFICE
 971 North Clark Street, Gilbert, AZ 85234
 TEL: 480.386.8058 FAX: 480.386.1010 WWW.TIMMONSGROUP.COM

CLIENT
nationalgrid
renewables

PROJECT NAME & ADDRESS
UBRIDLED SOLAR
 HENDERSON & WEBSTER COUNTY
 KENTUCKY

DATE: 12/02/2020
 PROJECT NUMBER: 46670
 DRAWN BY: R. SIERRA
 DESIGNED BY: S. UPADHYAY

SEAL
PRELIMINARY
NOT FOR CONSTRUCTION

REVISIONS

#	MM/DD/YY	DESCRIPTION
A	10/20/20	ISSUED FOR REVIEW
B	10/26/20	ISSUED FOR REVIEW
C	11/03/20	ISSUED FOR REVIEW
D	12/02/20	ISSUED FOR REVIEW
E		

DRAWING DESCRIPTION
 OVERALL TRANSMISSION LINE ROUTE MAP
 34"x22" FULL SIZE
 (17"x11" PLOTS ARE HALF SCALE)
 SCALE: 1" = 900'
 SHEET NUMBER: UNB-T-100-01

Y:\81146670_UBridled Solar\dwg\Electrical\State\6670E_MVCAB_22FT_statepermit.dwg | Printed on 12/22/2020 1:38 PM | by Ruben Sierra

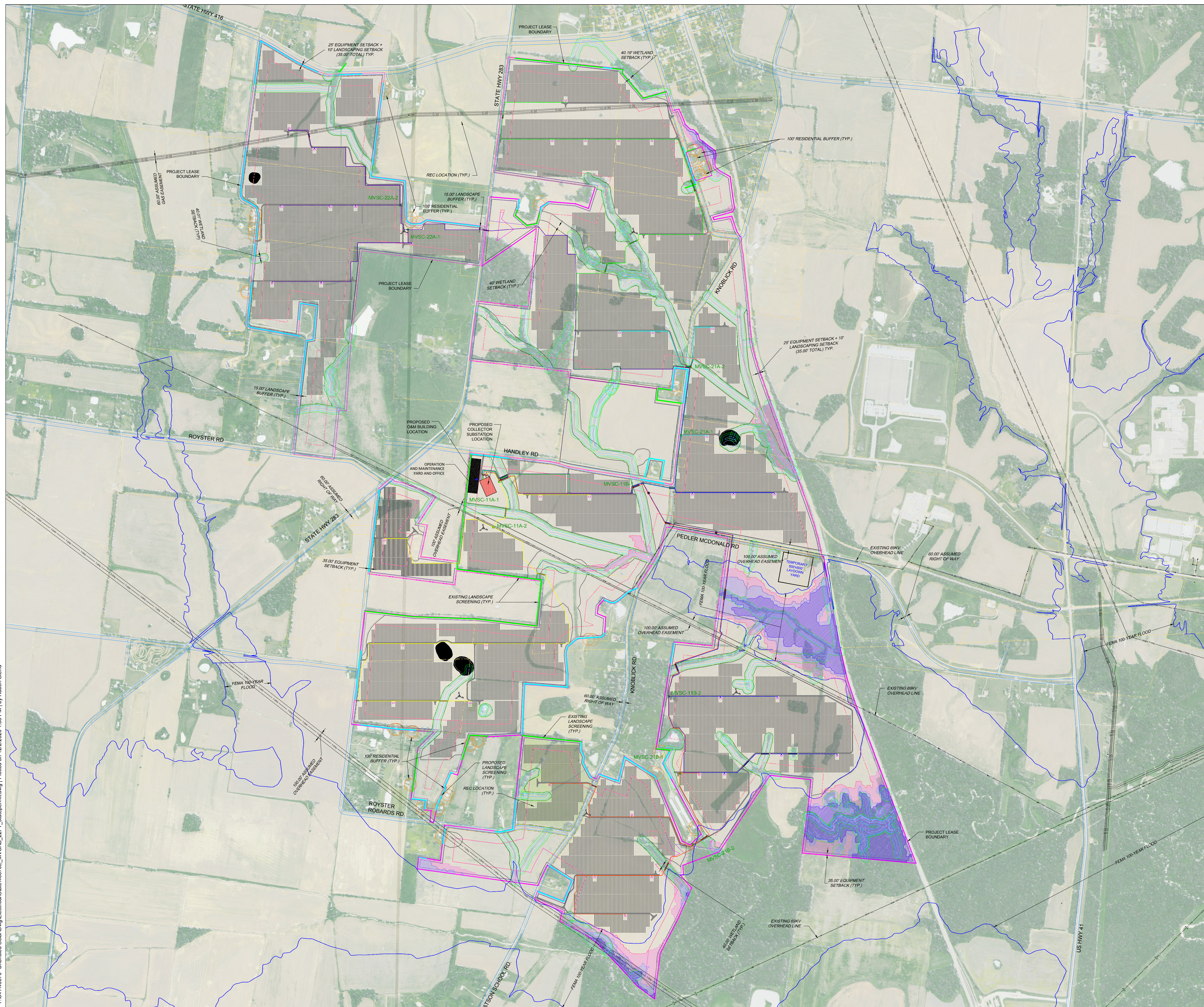

QUANTITY SUMMARY

SYSTEM DC RATING (MW)	211.05
SYSTEM DC CAPACITY TARGETED (MW)	210
SYSTEM AC CAPACITY (MW)	160
SYSTEM AC NAMEPLATE (MVA)	184.8
DC/AC RATIO (AT INVERTER)	1.14
DC/AC (AT POI)	1.32
MODULE MODEL	JA SOLAR JAM72D30 525/MB
GCR	34.2%
PITCH (CENTER TO CENTER)	22 FT.
TOTAL 525W MODULES	401,544
INVERTER MODEL	SMA SC4200US
TOTAL NUMBER INVERTERS	42 - 46
MODULES PER STRING	26
TOTAL STRINGS	15,444
DC SYSTEM VOLTAGE (V)	1500
COLLECTOR SYSTEM VOLTAGE (kV)	34.5
AZIMUTH	0°

LEGEND:

- PROJECT BOUNDARY (SUPPLIED KMZ)
- - - - EQUIPMENT SETBACK (SOLAR ORDINANCE)
- - - - 200' INVERTER SETBACK (ASSUMED 50dBA)
- WETLAND BOUNDARY (DELINEATION DATA)
- - - - 40' WETLAND SETBACK (KDOT)
- 100-YEAR FLOOD BOUNDARY (FEMA NFHL VIEWER)
- EXISTING ROADS (PUBLIC DATA)
- 69KV T-OHU — 69KV OVERHEAD LINE (BIG RIVER GIS)
- 161KV T-OHU — 161KV OVERHEAD LINE (BIG RIVER GIS)
- 345KV T-OHU — 345KV OVERHEAD LINE (BIG RIVER GIS)
- T-OHU — FOREIGN OVERHEAD LINE (BIG RIVER GIS)
- UTILITY EASEMENT (ASSUMED)
- 100' RESIDENTIAL BUFFER (HENDERSON COUNTY SOLAR ORDINANCE)
- EXISTING UTILITY POLE (SUPPLIED KMZ)
- ▨ 2' FLOW DEPTH (FLO-2D MODEL BY OTHERS)
- ▨ 4' FLOW DEPTH (FLO-2D MODEL BY OTHERS)
- ▨ 6' FLOW DEPTH (FLO-2D MODEL BY OTHERS)
- ▨ LANDSCAPE SCREENING EXISTING
- ▨ LANDSCAPE SCREENING
- ▨ PROPOSED SUBSTATION LOCATION
- ▨ PROPOSED O&M BUILDING LOCATION
- ▨ PROPOSED OPERATION & MAINTENANCE YARD & OFFICE
- ▨ PROPOSED SITE FENCE
- ▨ PROPOSED SITE ROAD
- PROPOSED CIRCUIT 11A
- PROPOSED CIRCUIT 11B
- PROPOSED CIRCUIT 21A
- PROPOSED CIRCUIT 21B
- PROPOSED CIRCUIT 22A
- PROPOSED CIRCUIT 22B
- MV JUNCTION BOX / MV SECTIONALIZING CABINET
- DIRECTIONAL BORE
- JUNCTION BOX
- INVERTER PAD
- ▭ PV PANEL TRACKER
- ▲ PROPOSED MET STATION

NOTE:
A SINGLE JB IS REQUIRED AT EVERY DIRECTIONAL BORE. CONTRACTOR SHALL DETERMINE PLACEMENT OF JB IN DIRECTIONAL BORING

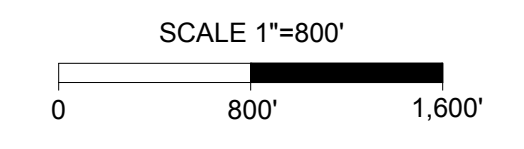
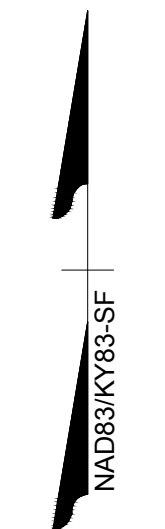

Call at least two full working days before you begin excavation.



TIMMONS GROUP
YOUR VISION ACHIEVED THROUGH OURS.
THIS DRAWING PREPARED AT THE
GILBERT OFFICE
971 North Collins Street, Suite 200
Tel: 460.386.8056 Fax: 801.561.1011 www.timmons.com

CLIENT
nationalgrid
renewables

PROJECT NAME & ADDRESS
UBRIDLED SOLAR
HENDERSON & WEBSTER COUNTY
KENTUCKY

DATE: 12/02/2020
PROJECT NUMBER: 46670
DRAWN BY: C. VU
DESIGNED BY: C. VU

PRELIMINARY
NOT FOR CONSTRUCTION

REVISIONS

#	AMOUNT	DESCRIPTION
A	10/20/20	ISSUED FOR REVIEW
B	10/26/20	ISSUED FOR REVIEW
C	11/03/20	ISSUED FOR REVIEW
D	12/02/20	ISSUED FOR REVIEW
E		

DRAWING DESCRIPTION
OVERALL SITE ARRAY PLAN

34"x22" FULL SIZE
(17"x11" PLOTS ARE HALF SCALE)

SCALE: 1" = 800'
SHEET NUMBER: UNB-E-500-03

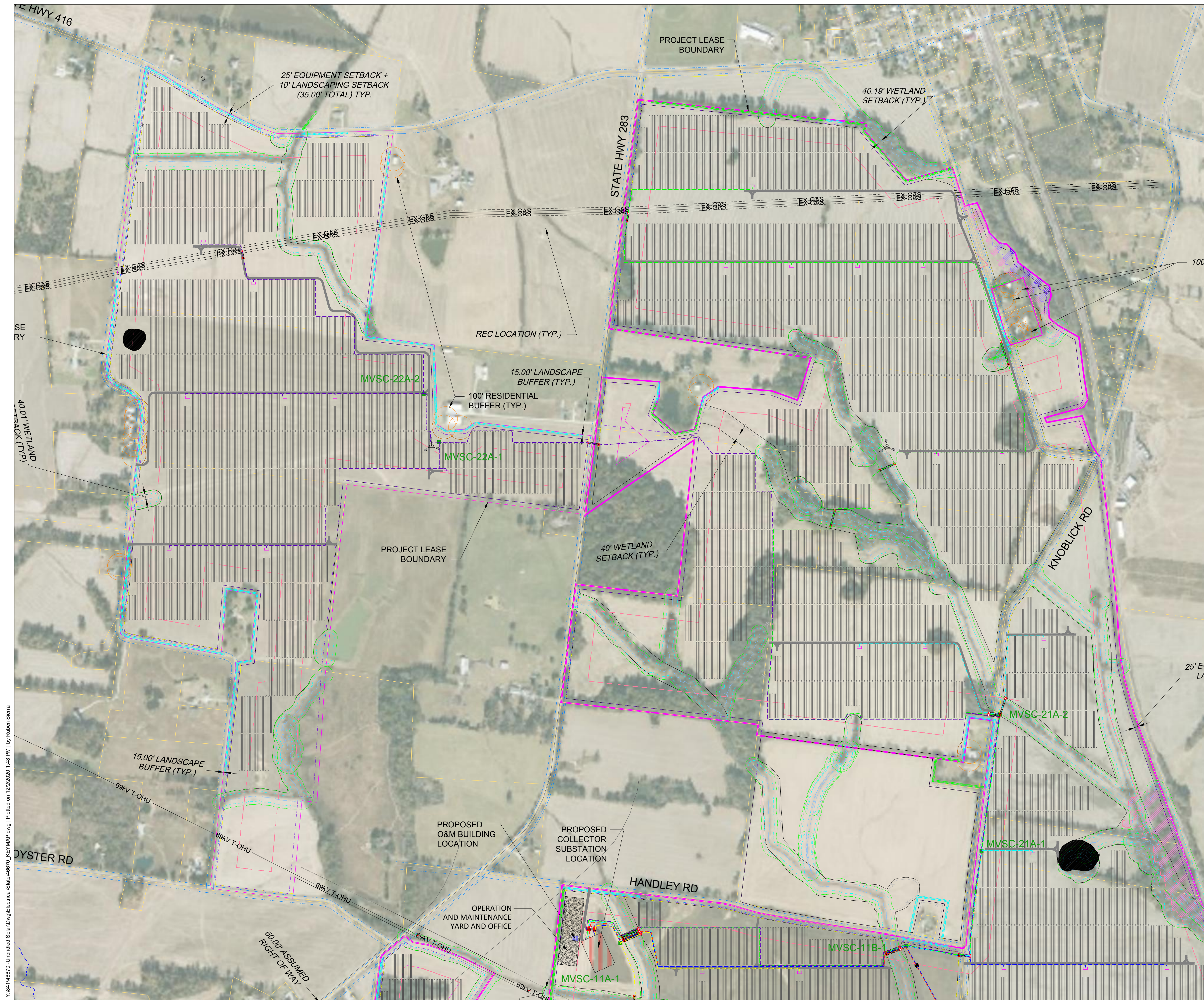

KEYMAP

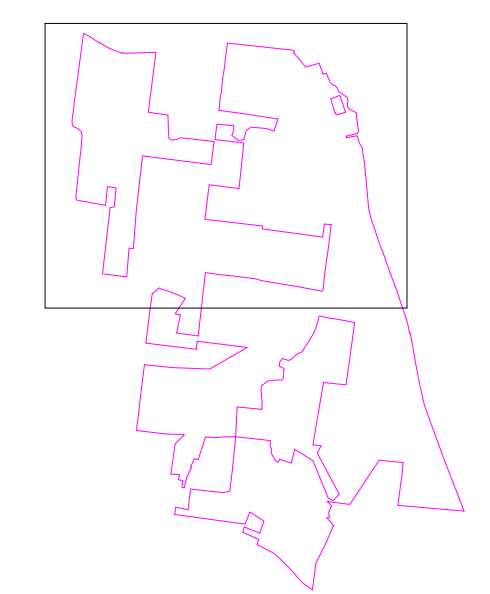

LEGEND:

- PROJECT BOUNDARY (SUPPLIED KMZ)
- EQUIPMENT SETBACK (SOLAR ORDINANCE)
- 200' INVERTER SETBACK (ASSUMED 500BA)
- WETLAND BOUNDARY (DELINEATION DATA)
- 40' WETLAND SETBACK (KDOT)
- 100-YEAR FLOOD BOUNDARY (FEMA NFHL VIEWER)
- EXISTING ROADS (PUBLIC DATA)
- 69KV T-OHU — 69KV OVERHEAD LINE (BIG RIVER GIS)
- 161KV T-OHU — 161KV OVERHEAD LINE (BIG RIVER GIS)
- 345KV T-OHU — 345KV OVERHEAD LINE (BIG RIVER GIS)
- T-OHU — FOREIGN OVERHEAD LINE (BIG RIVER GIS)
- UTILITY EASEMENT (ASSUMED)
- 100' RESIDENTIAL BUFFER (HENDERSON COUNTY SOLAR ORDINANCE)
- EXISTING UTILITY POLE (SUPPLIED KMZ)
- 2 FLOW DEPTH (FLO-2D MODEL BY OTHERS)
- 4 FLOW DEPTH (FLO-2D MODEL BY OTHERS)
- 6 FLOW DEPTH (FLO-2D MODEL BY OTHERS)
- LANDSCAPE SCREENING EXISTING
- LANDSCAPE SCREENING
- PROPOSED SUBSTATION LOCATION
- PROPOSED O&M BUILDING LOCATION
- PROPOSED OPERATION & MAINTENANCE YARD & OFFICE
- PROPOSED SITE FENCE
- PROPOSED SITE ROAD
- PROPOSED CIRCUIT 11A
- PROPOSED CIRCUIT 11B
- PROPOSED CIRCUIT 21A
- PROPOSED CIRCUIT 21B
- PROPOSED CIRCUIT 22A
- PROPOSED CIRCUIT 22B
- MV JUNCTION BOX / MV SECTIONALIZING CABINET
- DIRECTIONAL BORE
- JUNCTION BOX
- INVERTER PAD
- PV PANEL TRACKER
- PROPOSED MET STATION

NOTE:
A SINGLE JB IS REQUIRED AT EVERY DIRECTIONAL BORE. CONTRACTOR SHALL DETERMINE PLACEMENT OF JB IN DIRECTIONAL BORING

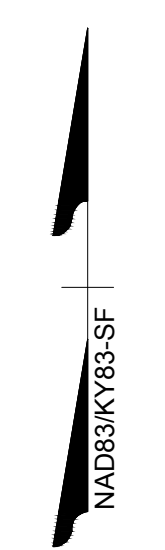

SCALE 1"=400'

Call at least two full working days before you begin excavation.



TIMMONS GROUP
YOUR VISION ACHIEVED THROUGH OURS.
THIS DRAWING PREPARED AT THE GILBERT OFFICE
971 North Gilbert, Gilbert, AZ 85234
TEL: 480.385.8058 FAX: 480.560.1010 WWW.TIMMONSGROUP.COM

nationalgrid renewables

UBRIDLED SOLAR
HENDERSON & WEBSTER COUNTY KENTUCKY

DATE: 12/02/2020
PROJECT NUMBER: 46670
DRAWN BY: R. SIERRA
DESIGNED BY: S. UPADHYAY

PRELIMINARY NOT FOR CONSTRUCTION

REVISIONS

#	AMOUNT	DESCRIPTION
A	10/20/20	ISSUED FOR REVIEW
B	10/26/20	ISSUED FOR REVIEW
C	11/03/20	ISSUED FOR REVIEW
D	12/02/20	ISSUED FOR REVIEW
E		

DRAWING DESCRIPTION: KEYMAP LAYOUT TOP

34"x22" FULL SIZE (17"x11" PLOTS ARE HALF SCALE)

SCALE	SHEET NUMBER
1" = 400'	UNB-E-502-01

Y:\04146670_Unbridled Solar\04146670-KeyMap.dwg | Plotted on 12/22/2020 1:48 PM | by Ruben Sierra



KEYMAP

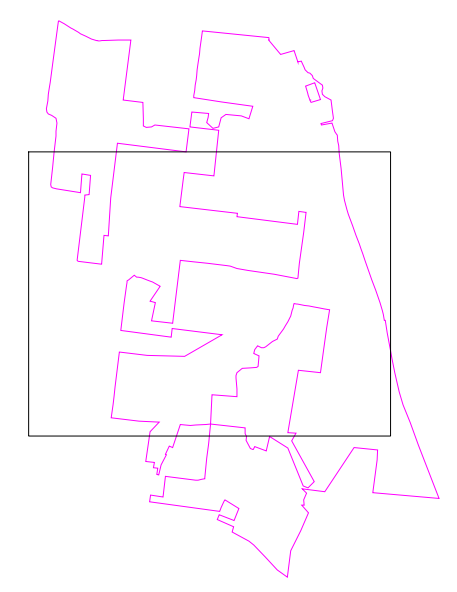

LEGEND:

- PROJECT BOUNDARY (SUPPLIED KMZ)
- EQUIPMENT SETBACK (SOLAR ORDINANCE)
- 200' INVERTER SETBACK (ASSUMED 50dBA)
- WETLAND BOUNDARY (DELINEATION DATA)
- 40' WETLAND SETBACK (KDOT)
- 100-YEAR FLOOD BOUNDARY (FEMA NFHL VIEWER)
- EXISTING ROADS (PUBLIC DATA)
- 69KV T-OHU 69KV OVERHEAD LINE (BIG RIVER GIS)
- 161KV T-OHU 161KV OVERHEAD LINE (BIG RIVER GIS)
- 345KV T-OHU 345KV OVERHEAD LINE (BIG RIVER GIS)
- T-OHU FOREIGN OVERHEAD LINE (BIG RIVER GIS)
- UTILITY EASEMENT (ASSUMED)
- 100' RESIDENTIAL BUFFER (HENDERSON COUNTY SOLAR ORDINANCE)
- EXISTING UTILITY POLE (SUPPLIED KMZ)
- 2 FLOW DEPTH (FLO-2D MODEL BY OTHERS)
- 4 FLOW DEPTH (FLO-2D MODEL BY OTHERS)
- 6 FLOW DEPTH (FLO-2D MODEL BY OTHERS)
- LANDSCAPE SCREENING EXISTING
- LANDSCAPE SCREENING
- PROPOSED SUBSTATION LOCATION
- PROPOSED O&M BUILDING LOCATION
- PROPOSED OPERATION & MAINTENANCE YARD & OFFICE
- PROPOSED SITE FENCE
- PROPOSED SITE ROAD
- PROPOSED CIRCUIT 11A
- PROPOSED CIRCUIT 11B
- PROPOSED CIRCUIT 21A
- PROPOSED CIRCUIT 21B
- PROPOSED CIRCUIT 22A
- PROPOSED CIRCUIT 22B
- MV JUNCTION BOX / MV SECTIONALIZING CABINET
- DIRECTIONAL BORE
- JUNCTION BOX
- INVERTER PAD
- PV PANEL TRACKER
- PROPOSED MET STATION

NOTE:
A SINGLE JB IS REQUIRED AT EVERY DIRECTIONAL BORE. CONTRACTOR SHALL DETERMINE PLACEMENT OF JB IN DIRECTIONAL BORING

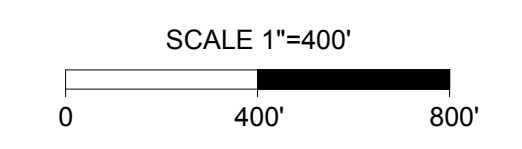
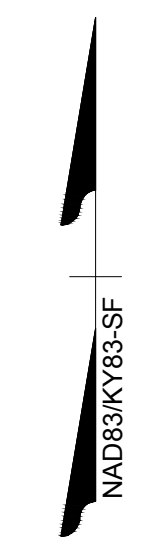

Call at least two full working days before you begin excavation.



TIMMONS GROUP
YOUR VISION ACHIEVED THROUGH OURS.
THIS DRAWING PREPARED AT THE
GILBERT OFFICE
971 North Gilbert Road, Suite 204 | Gilbert, AZ 85234
TEL 480.366.8050 FAX 480.360.1016 www.timmons.com

nationalgrid
renewables

UBRIDLED SOLAR
HENDERSON & WEBSTER COUNTY
KENTUCKY

DATE	12/02/2020
PROJECT NUMBER	46670
DRAWN BY	R. SIERRA
DESIGNED BY	S. UPADHYAY

PRELIMINARY
NOT FOR CONSTRUCTION

#	MM/DD/YY	DESCRIPTION
A	10/20/20	ISSUED FOR REVIEW
B	10/26/20	ISSUED FOR REVIEW
C	11/03/20	ISSUED FOR REVIEW
D	12/02/20	ISSUED FOR REVIEW
E		

DRAWING DESCRIPTION	
KEYMAP LAYOUT CENTER	
SCALE	SHEET NUMBER
1" = 400'	UNB-E-502-02

Y:\84146670_UBRIDLED Solar\Drawings\Electrical\State\46670_KEYMAP.dwg | Plotted on 12/22/2020 1:50 PM by Ruben Sierra

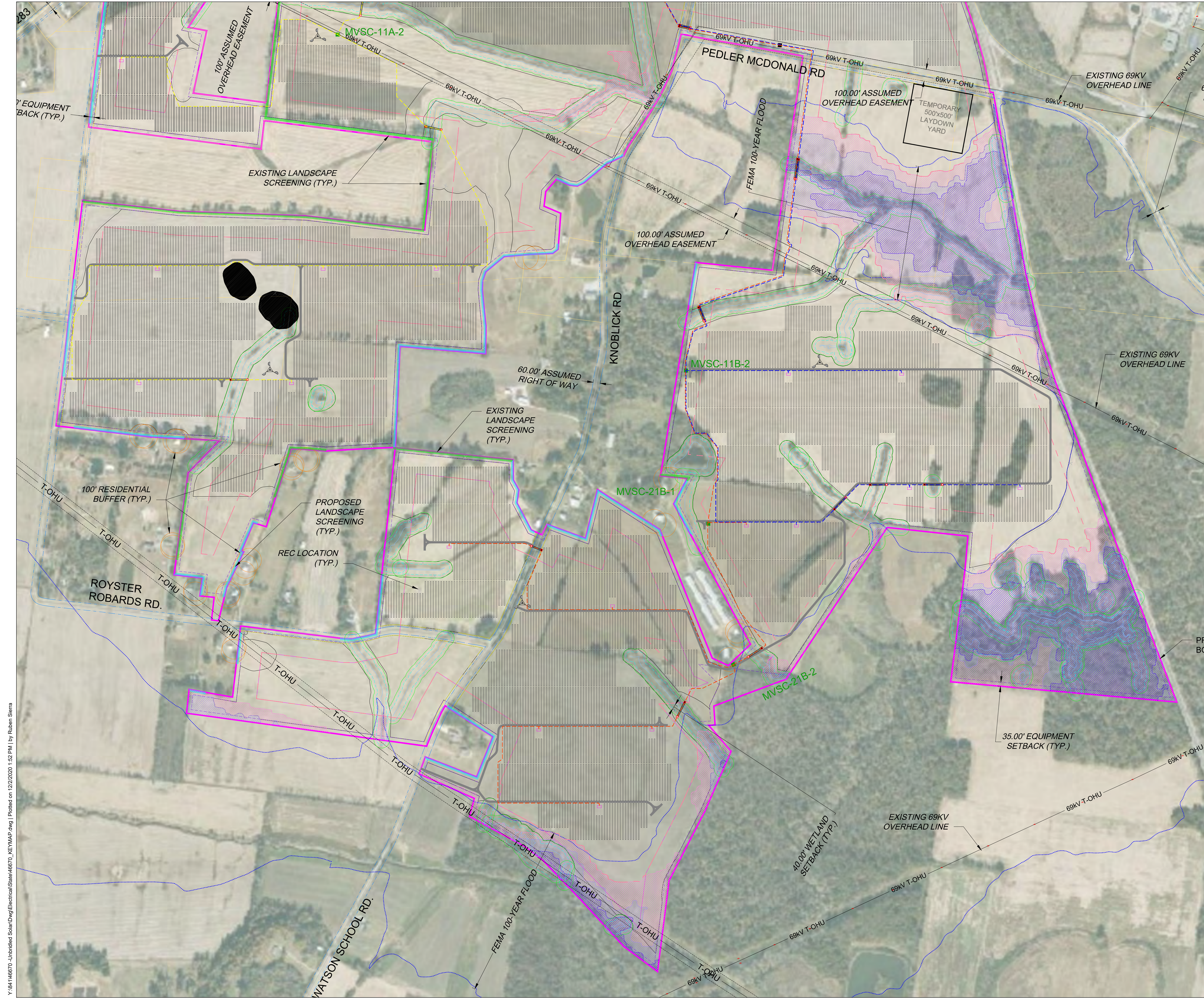

KEYMAP

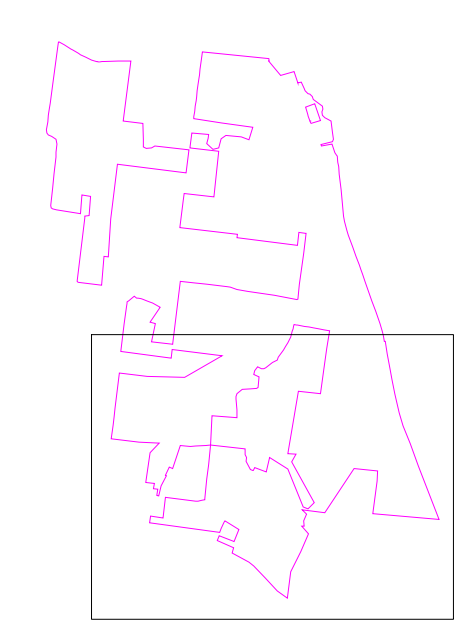

LEGEND:

- PROJECT BOUNDARY (SUPPLIED KMZ)
- - - EQUIPMENT SETBACK (SOLAR ORDINANCE)
- - - 200' INVERTER SETBACK (ASSUMED 50dBA)
- - - WETLAND BOUNDARY (DELINEATION DATA)
- - - 40' WETLAND SETBACK (KDOT)
- - - 100-YEAR FLOOD BOUNDARY (FEMA NFHL VIEWER)
- - - EXISTING ROADS (PUBLIC DATA)
- 69KV T-OHU — 69KV OVERHEAD LINE (BIG RIVER GIS)
- 161KV T-OHU — 161KV OVERHEAD LINE (BIG RIVER GIS)
- 345KV T-OHU — 345KV OVERHEAD LINE (BIG RIVER GIS)
- T-OHU — FOREIGN OVERHEAD LINE (BIG RIVER GIS)
- - - UTILITY EASEMENT (ASSUMED)
- - - 100' RESIDENTIAL BUFFER (HENDERSON COUNTY SOLAR ORDINANCE)
- EXISTING UTILITY POLE (SUPPLIED KMZ)
- ▨ 2' FLOW DEPTH (FLO-2D MODEL BY OTHERS)
- ▨ 4' FLOW DEPTH (FLO-2D MODEL BY OTHERS)
- ▨ 6' FLOW DEPTH (FLO-2D MODEL BY OTHERS)
- ▨ LANDSCAPE SCREENING EXISTING
- ▨ LANDSCAPE SCREENING
- ▨ PROPOSED SUBSTATION LOCATION
- ▨ PROPOSED O&M BUILDING LOCATION
- ▨ PROPOSED OPERATION & MAINTENANCE YARD & OFFICE
- ▨ PROPOSED SITE FENCE
- ▨ PROPOSED SITE ROAD
- ▨ PROPOSED CIRCUIT 11A
- ▨ PROPOSED CIRCUIT 11B
- ▨ PROPOSED CIRCUIT 21A
- ▨ PROPOSED CIRCUIT 21B
- ▨ PROPOSED CIRCUIT 22A
- ▨ PROPOSED CIRCUIT 22B
- ▨ MV JUNCTION BOX / MV SECTIONALIZING CABINET
- ▨ DIRECTIONAL BORE
- ▨ JUNCTION BOX
- ▨ INVERTER PAD
- ▨ PV PANEL TRACKER
- ▨ PROPOSED MET STATION

NOTE:
A SINGLE JB IS REQUIRED AT EVERY DIRECTIONAL BORE. CONTRACTOR SHALL DETERMINE PLACEMENT OF JB IN DIRECTIONAL BORING

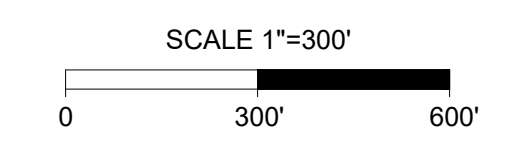
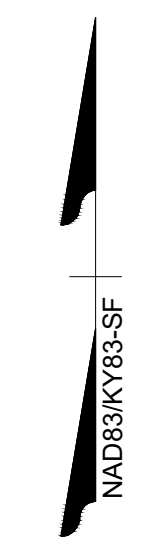

Call at least two full working days before you begin excavation.



TIMMONS GROUP
YOUR VISION ACHIEVED THROUGH OURS.
THIS DRAWING PREPARED AT THE GILBERT OFFICE
971 North Gilbert Road, Suite 204 | Gilbert, AZ 85234
TEL 480.366.8058 FAX 480.366.1016 www.timmons.com

nationalgrid
renewables

UBRIDLED SOLAR
HENDERSON & WEBSTER COUNTY
KENTUCKY

DATE	12/02/2020
PROJECT NUMBER	46670
DRAWN BY	R. SIERRA
DESIGNED BY	S. UPADHYAY

PRELIMINARY
NOT FOR CONSTRUCTION

#	MM/DD/YY	DESCRIPTION
A	10/20/20	ISSUED FOR REVIEW
B	10/26/20	ISSUED FOR REVIEW
C	11/03/20	ISSUED FOR REVIEW
D	12/02/20	ISSUED FOR REVIEW
E		

DRAWING DESCRIPTION	
KEYMAP LAYOUT BOTTOM	
34"x22" FULL SIZE (17"x11" PLOTS ARE HALF SCALE)	
SCALE	SHEET NUMBER
1" = 300'	UNB-E-502-03

Y:\84146670_Unbridled Solar\Drawings\Electrical\State\46670_KEYMAP.dwg [Plotted on 12/22/2020 1:52 PM] by Ruben Sierra

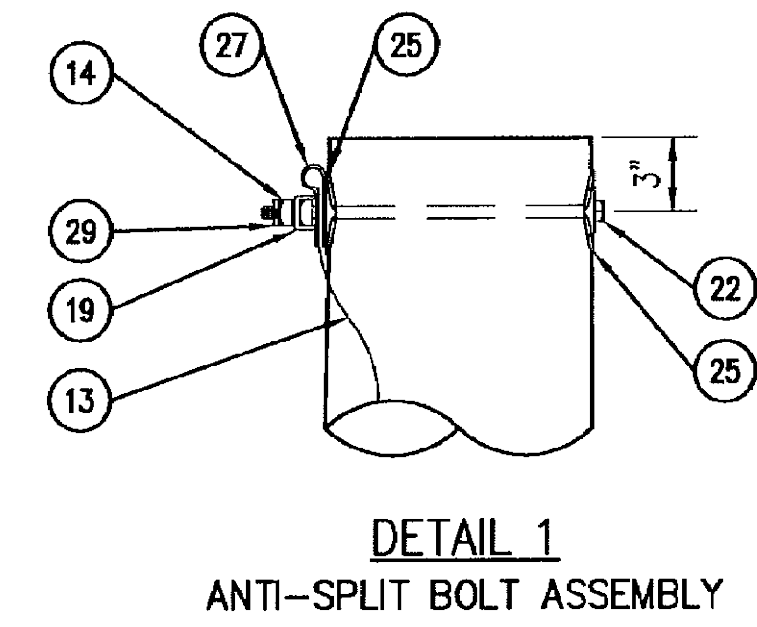
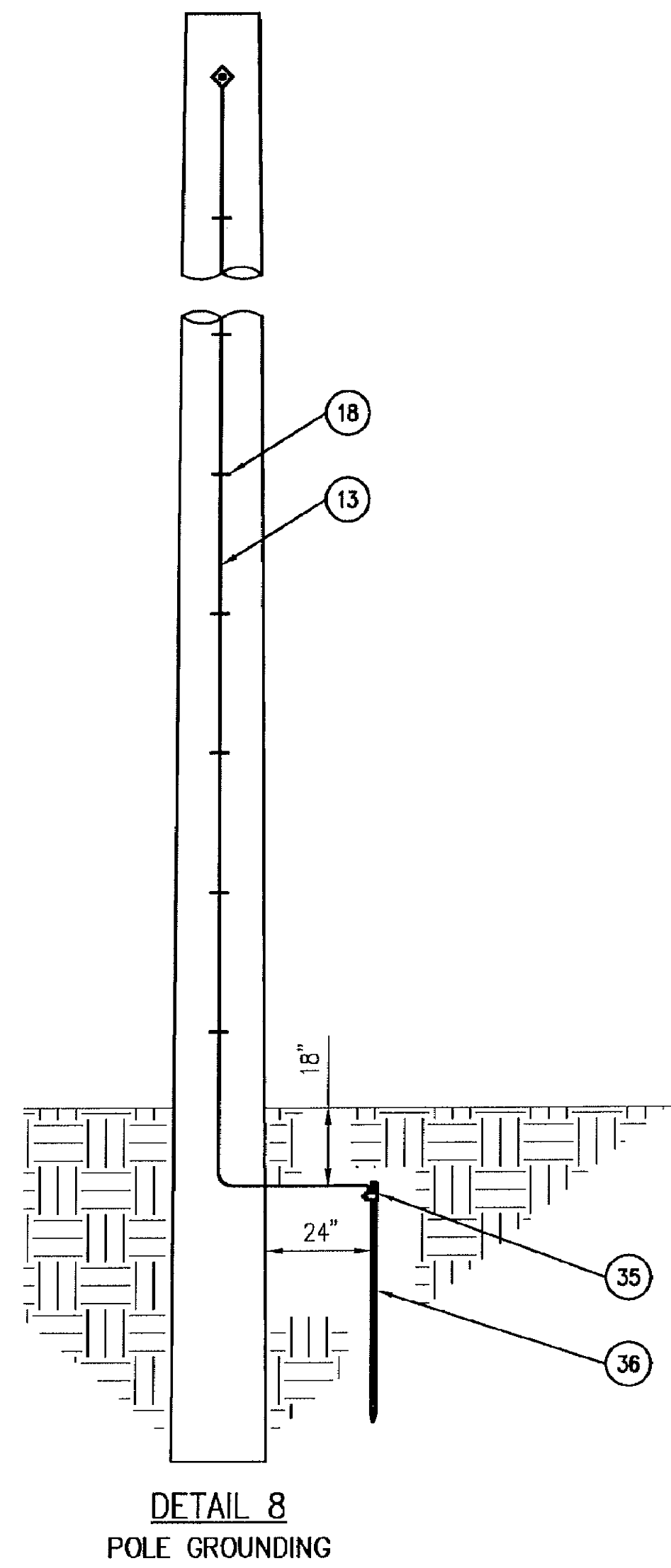
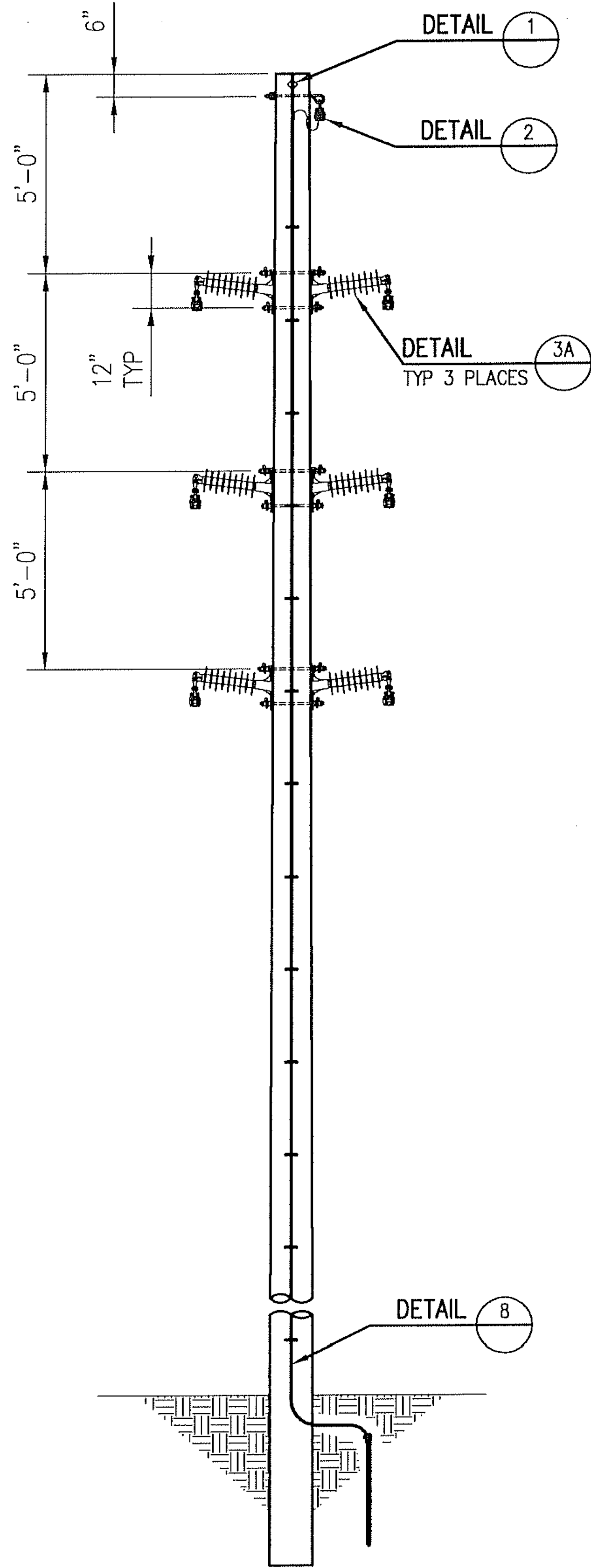
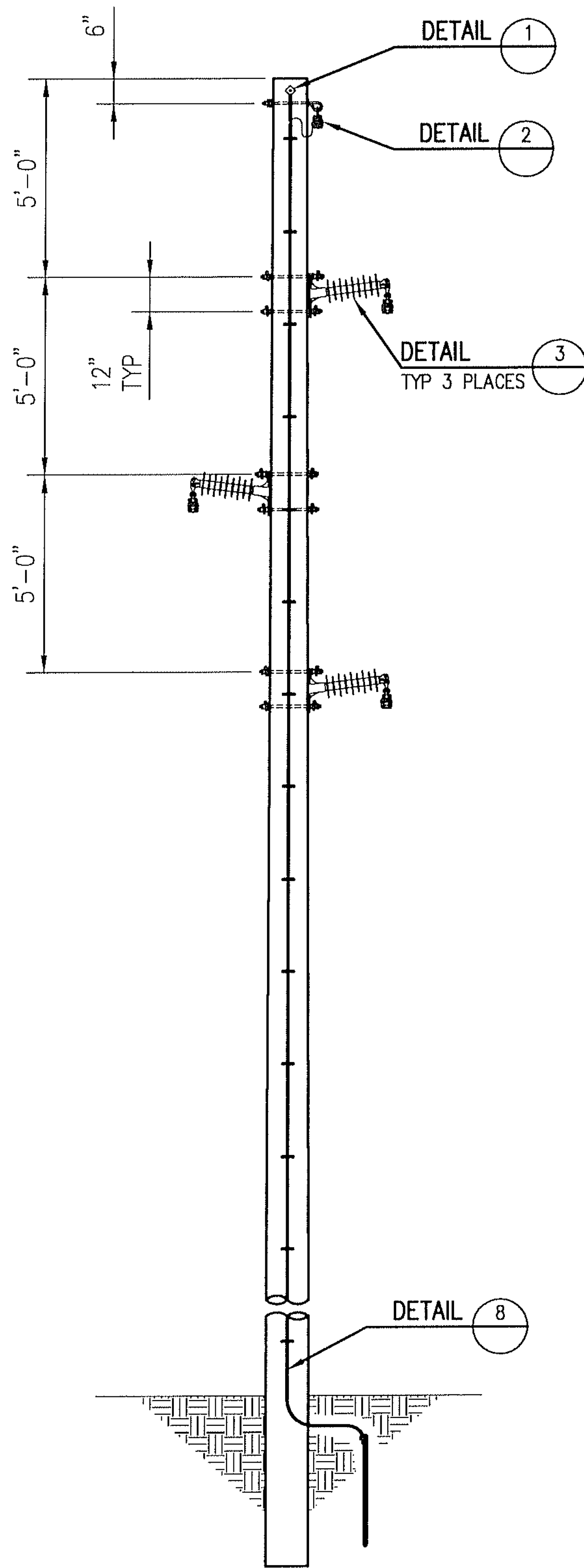

DETAIL 1
ANTI-SPLIT BOLT ASSEMBLY

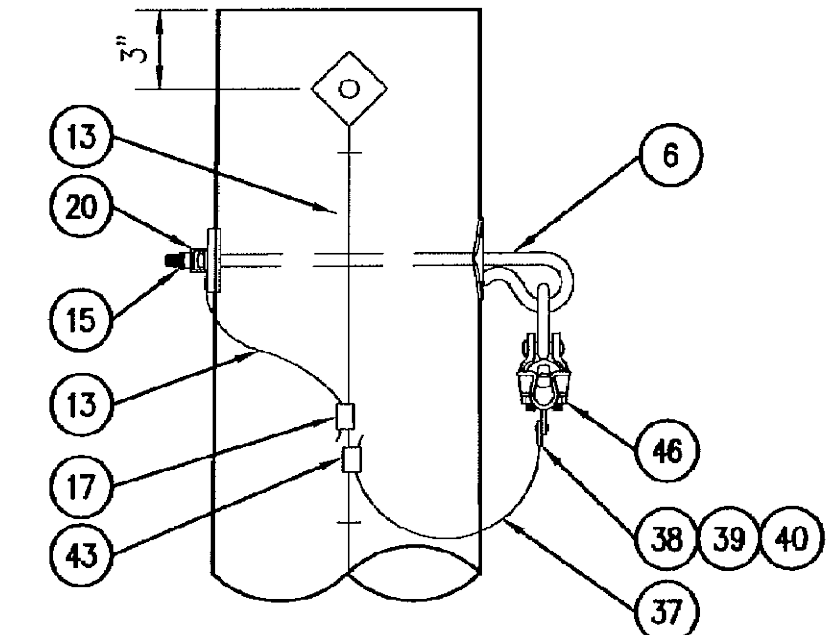

DETAIL 2
OPGW SUSPENSION ASSEMBLY

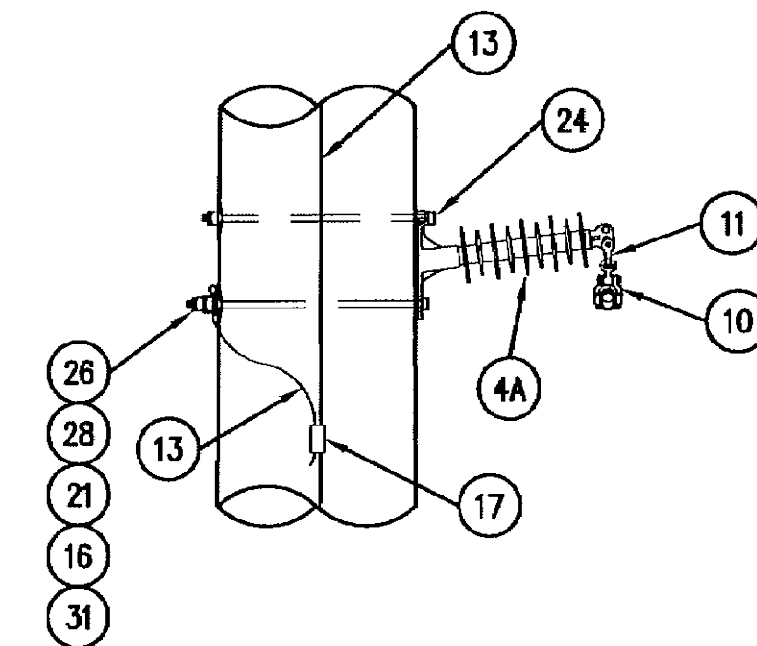

DETAIL 3
CONDUCTOR SUSPENSION ASSEMBLY

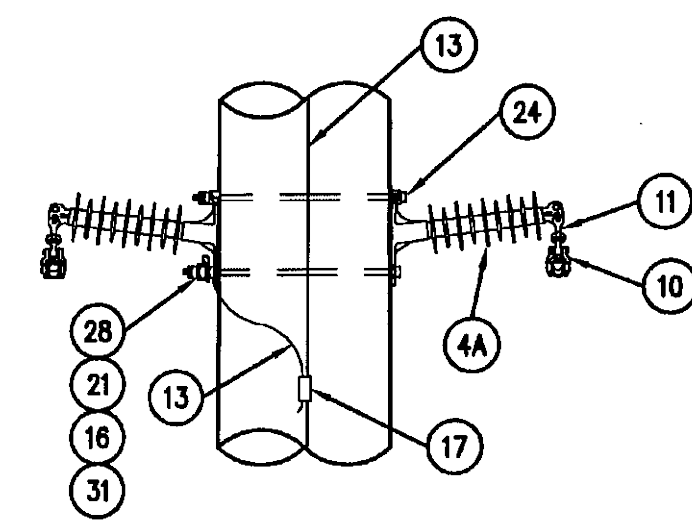

DETAIL 3A
CONDUCTOR SUSPENSION ASSEMBLY

REVISIONS	
#	DESCRIPTION
A	11/03/20 ISSUED FOR REVIEW
B	12/02/20 ISSUED FOR REVIEW
C	
D	
E	

DRAWING DESCRIPTION
TYPICAL OVERHEAD
COLLECTOR LINE DETAILS

Y:\94146670 - Unbridled Solar\Drawings\Electrical\46670-T-LINE DETAILS.dwg | Plotted on 12/22/2020 10:15 AM | by Ruben Sierra

GENERAL NOTES

PRE-CONSTRUCTION

- CONTRACTOR IS RESPONSIBLE FOR CONTACTING KENTUCKY 811 AT 1.800.752.6007 FOR LOCATION OF ALL UTILITY LINES. TREES SHALL BE LOCATED A MINIMUM OF 5 FEET FROM SEWER/WATER CONNECTIONS. NOTIFY LANDSCAPE ARCHITECT OF CONFLICTS.
- VERIFY ALL PLANT MATERIAL QUANTITIES ON THE PLAN PRIOR TO BIDDING. PLANT LIST TOTALS ARE FOR CONVENIENCE ONLY AND SHALL BE VERIFIED PRIOR TO BIDDING.
- PROVIDE PLANT MATERIALS OF QUANTITY, SIZE, GENUS, SPECIES, AND VARIETY INDICATED ON PLANS. ALL PLANT MATERIALS AND INSTALLATION SHALL COMPLY WITH RECOMMENDATIONS AND REQUIREMENTS OF ANSI Z60.1 "AMERICAN STANDARD FOR NURSERY STOCK". IF SPECIFIED PLANT MATERIAL IS NOT OBTAINABLE, SUBMIT PROOF OF NON AVAILABILITY TO THE LANDSCAPE ARCHITECT, TOGETHER WITH PROPOSAL FOR USE OF EQUIVALENT MATERIAL.
- PROVIDE AND INSTALL ALL PLANTS AS IN ACCORDANCE WITH DETAILS AND CONTRACT SPECIFICATIONS.
- SOIL TESTS SHALL BE PERFORMED TO DETERMINE SOIL CHARACTER AND QUALITY. NECESSARY SOIL AMENDMENTS SHALL BE PERFORMED PER TEST RESULTS TO ENSURE PLANT HEALTH.

CONSTRUCTION/INSTALLATION

- LANDSCAPE ARCHITECT RESERVES THE RIGHT TO REJECT ANY PLANTS AND MATERIALS THAT ARE IN AN UNHEALTHY OR UNSIGHTLY CONDITION, AS WELL AS PLANTS AND MATERIALS THAT DO NOT CONFORM TO ANSI Z60.1 "AMERICAN STANDARD FOR NURSERY STOCK" LABEL AT LEAST ONE TREE AND ONE SHRUB OF EACH VARIETY AND CALIPER WITH A SECURELY ATTACHED, WATERPROOF TAG BEARING THE DESIGNATION OF BOTANICAL AND COMMON NAME.
- INSTALL LANDSCAPE PLANTINGS AT ENTRANCES/EXITS AND PARKING AREAS ACCORDING TO PLANS SO THAT MATERIALS WILL NOT INTERFERE WITH SIGHT DISTANCES.
- CONTRACTOR IS RESPONSIBLE FOR WATERING ALL PLANT MATERIAL DURING INSTALLATION AND UNTIL FINAL INSPECTION AND ACCEPTANCE BY OWNER. CONTRACTOR SHALL NOTIFY OWNER OF CONDITIONS WHICH AFFECTS THE GUARANTEE.

INSPECTIONS/GUARANTEE

- UPON COMPLETION OF LANDSCAPE INSTALLATION, THE LANDSCAPE CONTRACTOR SHALL NOTIFY THE GENERAL CONTRACTOR WHO WILL VERIFY COMPLETENESS, INCLUDING THE REPLACEMENT OF ALL DEAD PLANT MATERIAL. CONTRACTOR IS RESPONSIBLE FOR SCHEDULING A FINAL INSPECTION BY THE LANDSCAPE ARCHITECT.
- ALL EXTERIOR PLANT MATERIALS SHALL BE GUARANTEED FOR ONE FULL YEAR AFTER DATE OF FINAL INSPECTION AGAINST DEFECTS INCLUDING DEATH AND UNSATISFACTORY GROWTH. DEFECTS RESULTING FROM NEGLIGENCE BY THE OWNER, ABUSE OR DAMAGE BY OTHERS, OR UNUSUAL PHENOMENA OR INCIDENTS WHICH ARE BEYOND THE CONTRACTORS CONTROL ARE NOT THE RESPONSIBILITY OF THE CONTRACTOR.
- PLANT MATERIAL QUANTITIES AND SIZES WILL BE INSPECTED FOR COMPLIANCE WITH APPROVED PLANS BY A SITE PLAN REVIEW AGENT OF THE PLANNING DEPARTMENT PRIOR TO THE RELEASE OF THE CERTIFICATE OF OCCUPANCY.
- REMOVE ALL GUY WIRES AND STAKES 12 MONTHS AFTER INSTALLATION.

5 GENERAL NOTES AND DETAILS

NTS

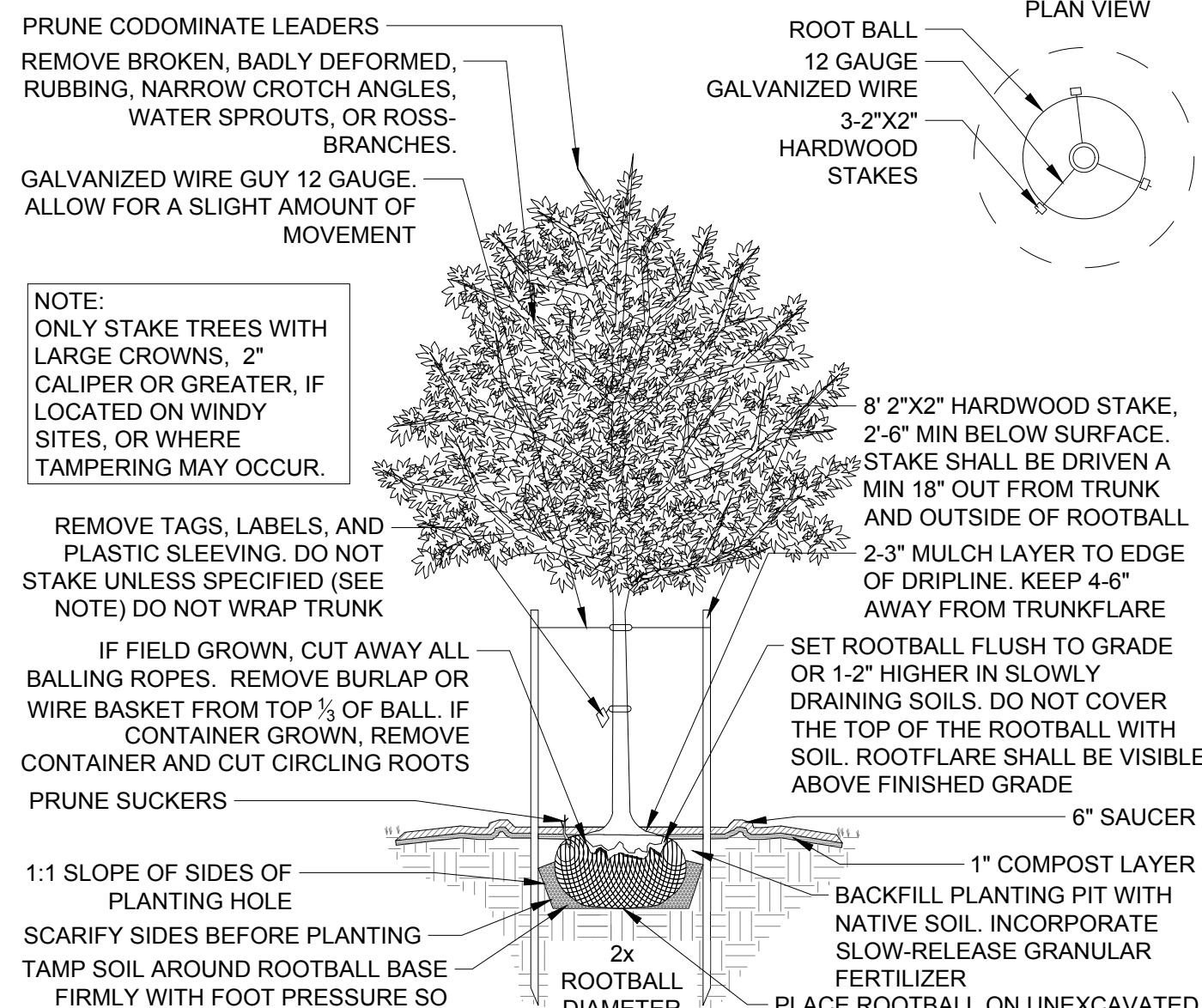

2 DECIDUOUS TREE PLANTING DETAIL

NTS

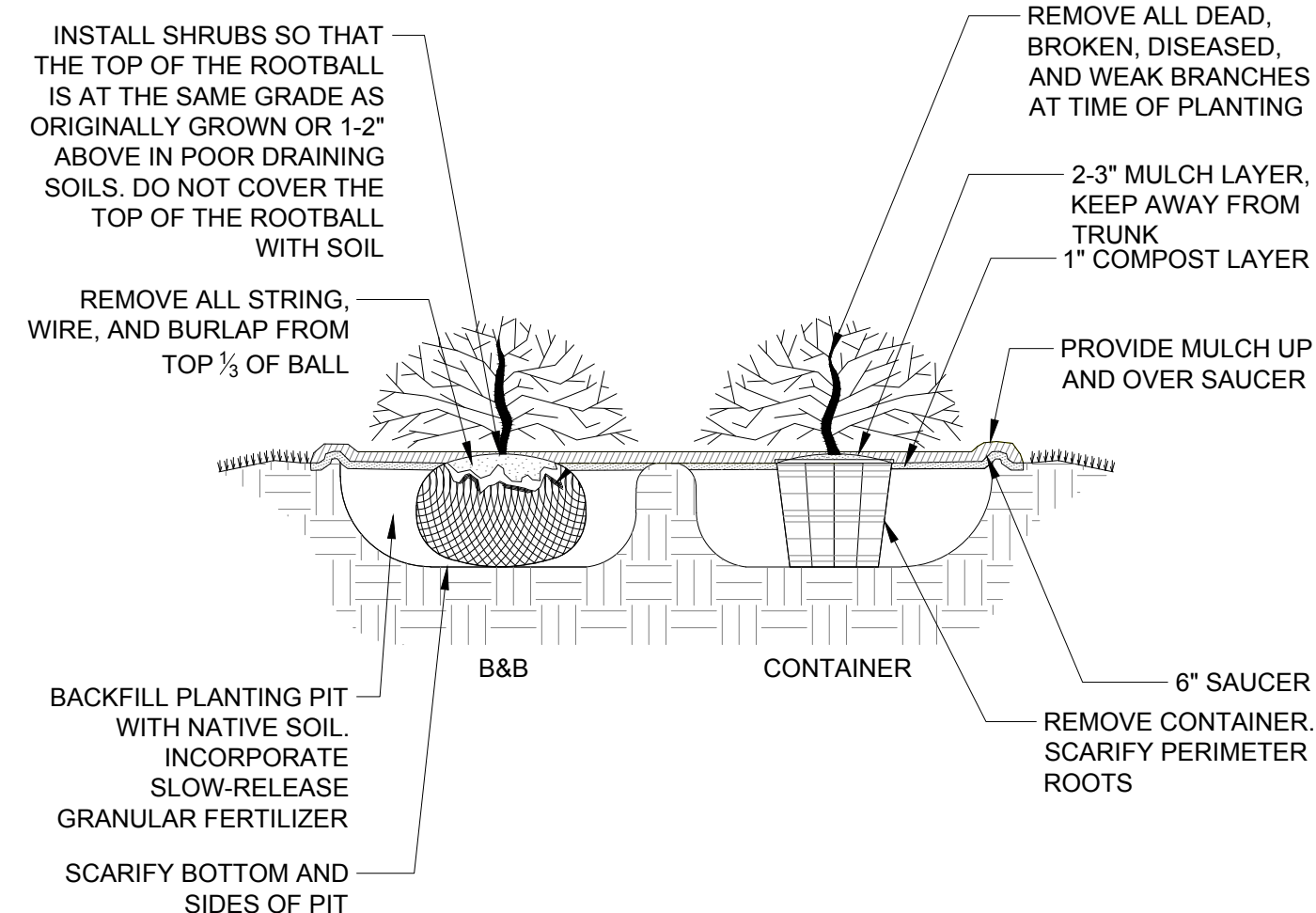

4 SHRUB PLANTING DETAIL

NTS



ILEX X 'CONAF' OAKLEAF / RED/OAKLEAF HOLLY



JUNIPERUS VIRGINIANA 'BRODIE' / EASTERN RED CEDAR 'TECHNY'



THUJA OCCIDENTALIS / EASTERN ARBORVITAE

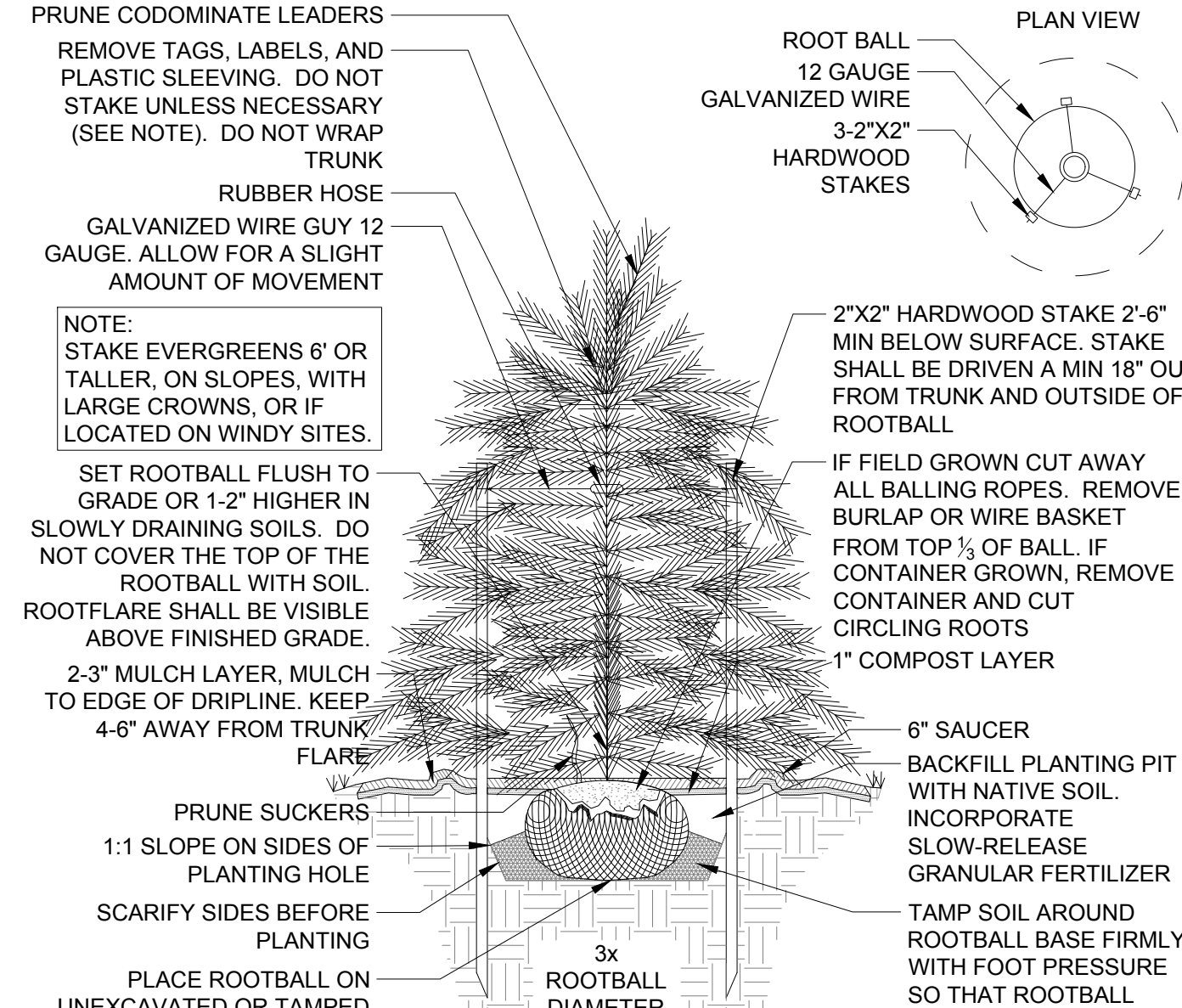

1 EVERGREEN TREE PLANTING DETAIL

NTS

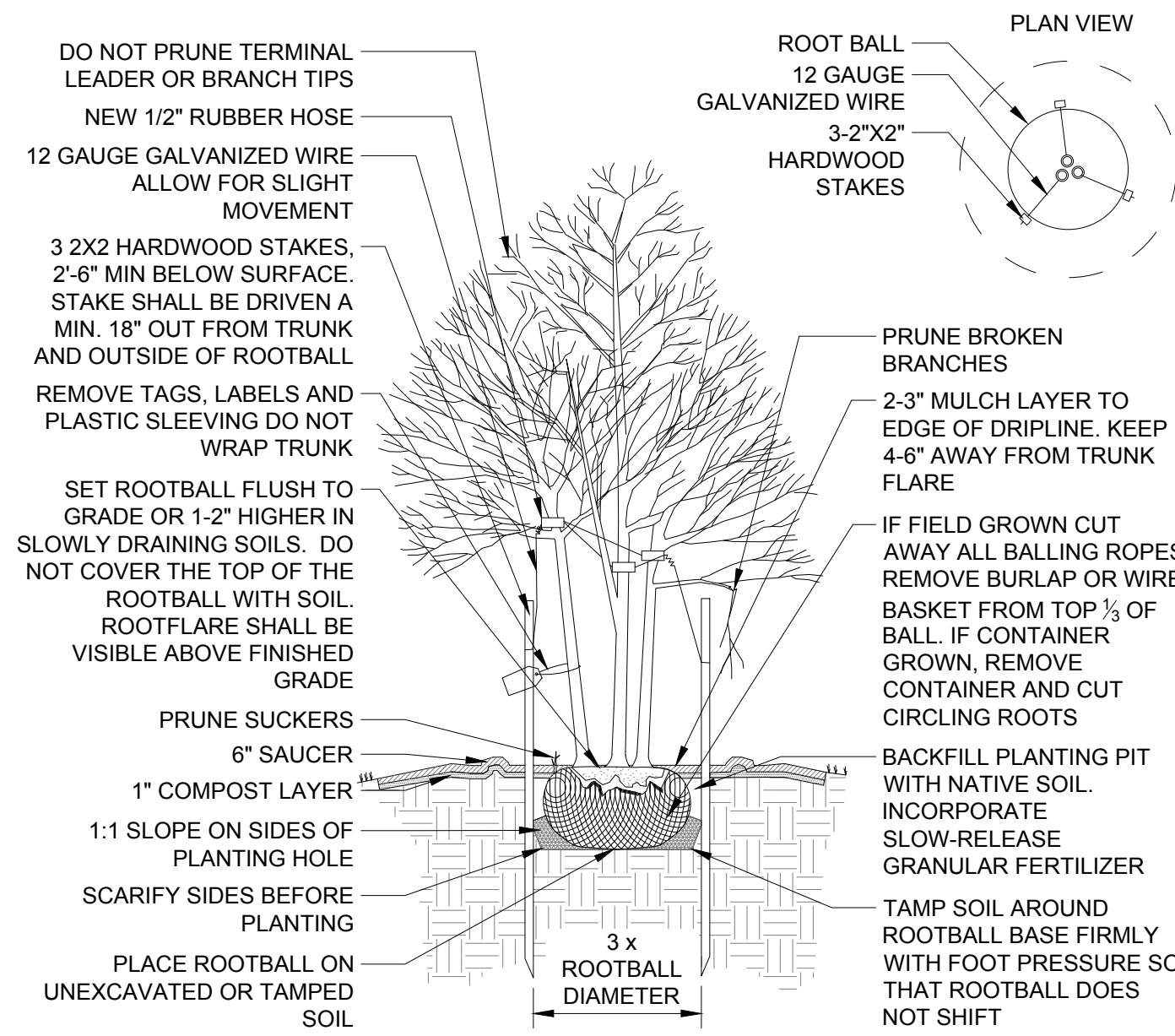

3 MULTI-STEM TREE PLANTING DETAIL

NTS



AMELANCHIER CANADENSIS / SHADBLOW SERVICEBERRY



CERCIS CANADENSIS / EASTERN RED BUD



CORNUS FLORIDA / FLOWERING DOGWOOD



ILEX VERTICILLATA / 'WINTER RED' / WINTERBERRY



PRUNUS LAUROCERASUS / 'SCHIPKAENSIS' / SCHIPKA LAUREL



VIBURNUM 'PRAGENSE' / PRAGUE VIBURNUM

VEGETATION SCREENING CONCEPT PLAN

ALTERNATIVE PLAN PROPOSED

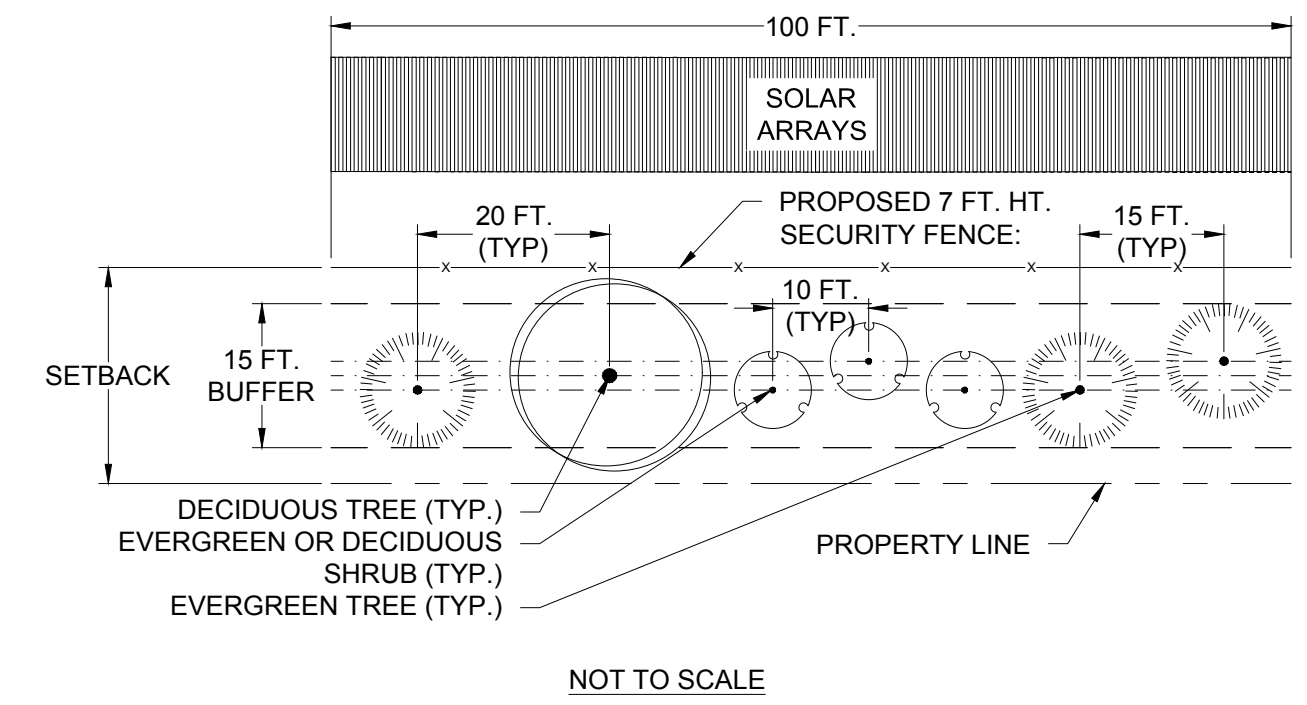

AT PLANTING

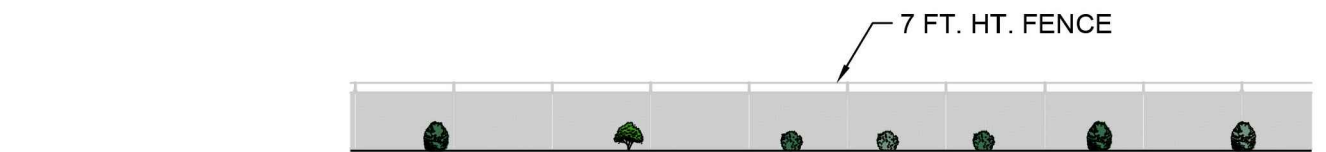

5 YEARS AFTER PLANTING

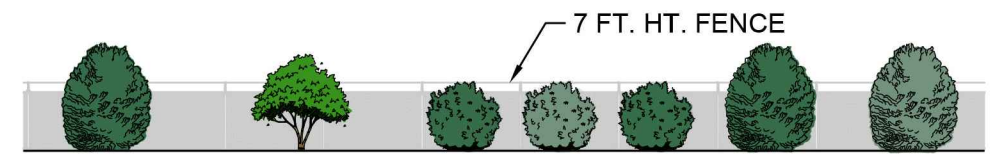

AT MATURITY

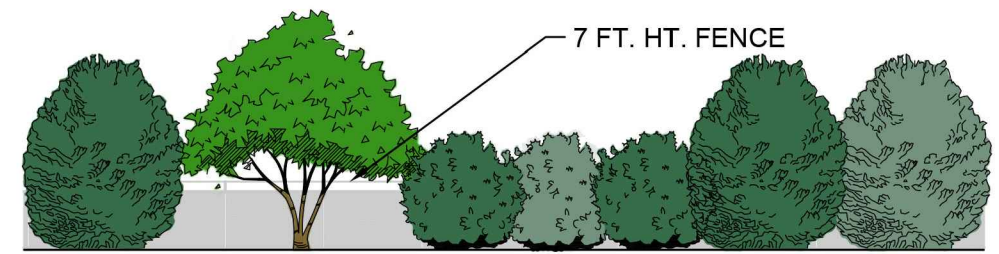

PER 100 LINEAR FEET:

- THREE (3) MEDIUM/SMALL EVERGREEN TREES
- ONE (1) MEDIUM/SMALL DECIDUOUS TREE
- THREE (3) LARGE/MEDIUM EVERGREEN AND DECIDUOUS SHRUBS

NOTES

- SCREENING CONSISTS OF A MIXED PLANTING OF DECIDUOUS AND EVERGREEN TREES AND SHRUBS THAT HAVE BEEN SELECTED FOR SCREENING AT MATURE HEIGHT.
- EVERGREEN AND DECIDUOUS TREES ARE 3 FT. HEIGHT AND EVERGREEN AND DECIDUOUS SHRUBS ARE 24 IN. HEIGHT AT PLANTING.
- WHERE EXISTING TREES OR SHRUBS EXIST IN THE PROPOSED BUFFER LOCATION, PROPOSED SCREENING MUST BE FIELD-LOCATED AND PLANTED AS NEEDED TO SUPPLEMENT THE EXISTING VEGETATIVE SCREENING.
- VARY THE SPECIES USED FOR EACH OF THE THREE TYPES OF PLANTS (EVERGREEN TREES, DECIDUOUS TREES, SHRUBS) EVERY 200 LINEAR FEET.

RECOMMENDED PLANT MATERIAL

MEDIUM/SMALL EVERGREEN TREES

BOTANICAL NAME / COMMON NAME
 ILEX X 'CONAF' OAKLEAF / RED HOLLY/OAKLEAF HOLLY
 JUNIPERUS VIRGINIANA 'BRODIE' / EASTERN RED CEDAR
 THUJA OCCIDENTALIS 'TECHNY' / EASTERN ARBORVITAE

MEDIUM/SMALL DECIDUOUS TREES

BOTANICAL NAME / COMMON NAME
 AMELANCHIER CANADENSIS / SHADBLOW SERVICEBERRY
 CERCIS CANADENSIS / EASTERN RED BUD
 CORNUS FLORIDA / FLOWERING DOGWOOD

LARGE/MEDIUM EVERGREEN AND DECIDUOUS SHRUBS

BOTANICAL NAME / COMMON NAME
 ILEX VERTICILLATA 'WINTER RED' AND 'SOUTHERN GENTLEMAN' / WINTERBERRY
 PRUNUS LAUROCERASUS 'SCHIPKAENSIS' / SCHIPKA CHERRY LAUREL
 VIBURNUM 'PRAGENSE' / PRAGUE VIBURNUM

* NEED BOTH THE FEMALE AND MALE CULTIVARS LISTED FOR POLLINATION AND FRUIT PRODUCTION. PLANT ONE (1) MALE PER THREE (3) FEMALES.



PROJECT NAME & ADDRESS
UBRIDLED SOLAR
 HENDERSON & WEBSTER COUNTY
 KENTUCKY

DATE: 10/16/2020
 PROJECT NUMBER: 46670
 DRAWN BY: T. BUCKLEY
 DESIGNED BY: T. BUCKLEY

SEAL
PRELIMINARY
NOT FOR CONSTRUCTION

#	AMOUNT	DESCRIPTION
A	10/19/20	ISSUED FOR REVIEW
B	11/03/20	ISSUED FOR REVIEW
C	12/02/20	ISSUED FOR REVIEW
D		
E		

DRAWING DESCRIPTION
 VEGETATION SCREENING NOTES AND DETAILS

34"x22" FULL SIZE
 (17"x11" PLOTS ARE HALF SCALE)
 SCALE: N.T.S. SHEET NUMBER: UNB-L-900-01

\\timmons.com\img\900194\146670 - Unbridled Solar\046670-VEGETATION_SCREENING_NOTES_AND_DETAILS.rvt | Plotted on: 11/25/2020 1:12 PM | by: Bradley Davis