

COMMONWEALTH OF KENTUCKY
BEFORE THE PUBLIC SERVICE COMMISSION

In the Matter of:

ELECTRONIC APPLICATION OF)
LOUISVILLE GAS AND ELECTRIC) CASE NO. 2018-00295
COMPANY FOR AN ADJUSTMENT OF ITS)
ELECTRIC AND GAS RATES)

RESPONSE OF
LOUISVILLE GAS AND ELECTRIC COMPANY
TO
FIRST REQUEST FOR INFORMATION
OF THE LOUISVILLE/JEFFERSON COUNTY METRO GOVERNMENT
DATED NOVEMBER 13, 2018

FILED: NOVEMBER 29, 2018

VERIFICATION

COMMONWEALTH OF KENTUCKY)
)
COUNTY OF JEFFERSON)

The undersigned, **Daniel K. Arbough**, being duly sworn, deposes and says that he is Treasurer for Kentucky Utilities Company and Louisville Gas and Electric Company and an employee of LG&E and KU Services Company, and that he has personal knowledge of the matters set forth in the responses for which he is identified as the witness, and the answers contained therein are true and correct to the best of his information, knowledge and belief.

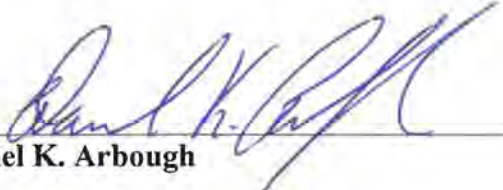
Daniel K. Arbough

Subscribed and sworn to before me, a Notary Public in and before said County and State, this 29th day of November 2018.

Notary Public

My Commission Expires:
Judy Schooler
Notary Public, ID No. 603967
State at Large, Kentucky
Commission Expires 7/11/2022

VERIFICATION

COMMONWEALTH OF KENTUCKY)
)
COUNTY OF JEFFERSON)

The undersigned, **Robert M. Conroy**, being duly sworn, deposes and says that he is Vice President, State Regulation and Rates, for Kentucky Utilities Company and Louisville Gas and Electric Company and an employee of LG&E and KU Services Company, and that he has personal knowledge of the matters set forth in the responses for which he is identified as the witness, and the answers contained therein are true and correct to the best of his information, knowledge and belief.



Robert M. Conroy

Subscribed and sworn to before me, a Notary Public in and before said County and State, this 29th day of November 2018.



Notary Public

My Commission Expires:
Judy Schooler
Notary Public, ID No. 603967
State at Large, Kentucky
Commission Expires 7/11/2022

VERIFICATION

COMMONWEALTH OF KENTUCKY)
)
COUNTY OF JEFFERSON)

The undersigned, **Christopher M. Garrett**, being duly sworn, deposes and says that he is Controller for Kentucky Utilities Company and Louisville Gas and Electric Company and an employee of LG&E and KU Services Company, and that he has personal knowledge of the matters set forth in the responses for which he is identified as the witness, and the answers contained therein are true and correct to the best of his information, knowledge and belief.

Christopher M. Garrett

Subscribed and sworn to before me, a Notary Public in and before said County and State, this 28th day of November 2018.

Notary Public

My Commission Expires:

Judy Schooler
Notary Public, ID No. 603967
State at Large, Kentucky
Commission Expires 7/11/2022

VERIFICATION

COMMONWEALTH OF KENTUCKY)
)
COUNTY OF JEFFERSON)

The undersigned, **Elizabeth J. McFarland**, being duly sworn, deposes and says that she is Vice President, Customer Services for Louisville Gas and Electric Company and Kentucky Utilities Company and an employee of LG&E and KU Services Company, and that she has personal knowledge of the matters set forth in the responses for which she is identified as the witness, and the answers contained therein are true and correct to the best of her information, knowledge and belief.

Elizabeth J. McFarland
Elizabeth J. McFarland

Subscribed and sworn to before me, a Notary Public in and before said County and State, this 29th day of November 2018.

Kimberly C Brook
Notary Public

My Commission Expires:

10-16-2020

VERIFICATION

STATE OF TEXAS)
) SS:
COUNTY OF TRAVIS)

The undersigned, **Adrien M. McKenzie**, being duly sworn, deposes and says he is President of FINCAP, Inc., that he has personal knowledge of the matters set forth in the responses for which he is identified as the witness, and the answers contained therein are true and correct to the best of his information, knowledge and belief.

Adrien M. McKenzie

Subscribed and sworn to before me, a Notary Public in and before said County and State, this 16th day of November 2018.

 (SEAL)
Notary Public

My Commission Expires:
04/17/2019

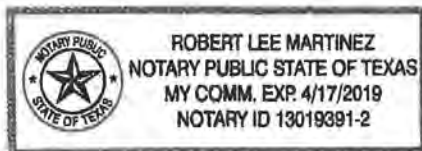

VERIFICATION

COMMONWEALTH OF KENTUCKY)
)
COUNTY OF JEFFERSON)

The undersigned, **Gregory J. Meiman**, being duly sworn, deposes and says that he is Vice President, Human Resources for Kentucky Utilities Company and Louisville Gas and Electric Company and an employee of LG&E and KU Services Company, and that he has personal knowledge of the matters set forth in the responses for which he is identified as the witness, and the answers contained therein are true and correct to the best of his information, knowledge and belief.

Gregory J. Meiman

Subscribed and sworn to before me, a Notary Public in and before said County and State, this 19th day of November 2018.

Notary Public

My Commission Expires:
Judy Schooler
Notary Public, ID No. 603967
State at Large, Kentucky
Commission Expires 7/11/2022

VERIFICATION

COMMONWEALTH OF KENTUCKY)
)
COUNTY OF JEFFERSON)

The undersigned, **William Steven Seelye**, being duly sworn, deposes and states that he is a Principal of The Prime Group, LLC, and that he has personal knowledge of the matters set forth in the responses for which he is identified as the witness, and the answers contained therein are true and correct to the best of his information, knowledge and belief.



William Steven Seelye

Subscribed and sworn to before me, a Notary Public in and before said County and State, this 20th day of November 2018.



Notary Public (SEAL)

My Commission Expires:
Judy Schooler
Notary Public, ID No. 603967
State at Large, Kentucky
Commission Expires 7/11/2022

VERIFICATION

COMMONWEALTH OF KENTUCKY)
)
COUNTY OF JEFFERSON)

The undersigned, **David S. Sinclair**, being duly sworn, deposes and says that he is Vice President, Energy Supply and Analysis for Kentucky Utilities Company and Louisville Gas and Electric Company and an employee of LG&E and KU Services Company, and that he has personal knowledge of the matters set forth in the responses for which he is identified as the witness, and the answers contained therein are true and correct to the best of his information, knowledge and belief.



David S. Sinclair

Subscribed and sworn to before me, a Notary Public in and before said County and State, this 29th day of November 2018.



Notary Public

My Commission Expires:

Judy Schooler
Notary Public, ID No. 603967
State at Large, Kentucky
Commission Expires 7/11/2022

VERIFICATION

COMMONWEALTH OF KENTUCKY)
)
COUNTY OF JEFFERSON)

The undersigned, **John K. Wolfe**, being duly sworn, deposes and says that he is Vice President, Electric Distribution for Kentucky Utilities Company and Louisville Gas and Electric Company and an employee of LG&E and KU Services Company, and that he has personal knowledge of the matters set forth in the responses for which he is identified as the witness, and the answers contained therein are true and correct to the best of his information, knowledge and belief.



John K. Wolfe

Subscribed and sworn to before me, a Notary Public in and before said County and State, this 28th day of November 2018.



Notary Public

My Commission Expires:
Judy Schooler
Notary Public, ID No. 603967
State at Large, Kentucky
Commission Expires 7/11/2022

LOUISVILLE GAS AND ELECTRIC COMPANY

**Response to First Request for Information of the
Louisville/Jefferson County Metro Government
Dated November 13, 2018**

Case No. 2018-00295

Question No. 1

Responding Witness: William Steven Seelye

Q-1. Please refer to Exhibit WSS-3.

- a. Please explain the methodology of the analysis that concluded that some customer bills would be lower under a 100% ratchet compared to a 75% ratchet. Include within your response an identification and explanation of all assumptions used in the analysis.
- b. For each customer in the analysis, please provide the maximum base demand and the average base demand for the 23-month period of study.
- c. In absolute terms, how much additional revenue was generated by increasing the ratchet from 75% to 100% during the test period?

A-1.

- a. An analysis was performed for each customer served under TOD-S calculating the change in annual billings with and without the ratchet change implemented in the Company's last rate case. The analysis assumed that the net overall revenue for the TOD-S customers would be the same for both cases, within rounding. All of the rate components for the 12 months ended June 30, 2018, were included in the calculation of the annual billings for each customer, including applicable demand charges, energy charges, fuel adjustment clause factors, demand-side management charges, environmental cost recovery charges, and the Tax Cuts and Jobs Act factors.
- b. See attached.
- c. None. The rates were designed to be revenue neutral.

23-Month TODS Average and Max Base Demands by Customer (Ranked by Avg)

CC Name	Average of KW/KVA Base Measured	Max of KW/KVA Base Measured
LG&E	2,636	2,720
KU	2,592	2,969
LG&E	2,472	3,264
LG&E	2,426	2,738
KU	2,228	2,784
KU	2,146	2,305
KU	1,992	2,494
LG&E	1,990	2,500
KU	1,981	2,203
LG&E	1,936	2,513
KU	1,815	1,986
LG&E	1,763	2,326
LG&E	1,762	2,148
LG&E	1,724	1,780
LG&E	1,708	1,897
KU	1,702	1,879
LG&E	1,683	2,231
LG&E	1,649	2,157
LG&E	1,644	5,098
LG&E	1,642	1,950
KU	1,640	2,311
LG&E	1,608	1,952
LG&E	1,603	2,056
LG&E	1,565	1,876
KU	1,564	1,858
KU	1,549	2,003
KU	1,511	1,921
LG&E	1,506	2,182
LG&E	1,491	1,828
LG&E	1,436	2,381
LG&E	1,434	1,964
LG&E	1,389	1,558
LG&E	1,387	1,744
KU	1,381	1,582
LG&E	1,366	2,372
LG&E	1,363	1,699
KU	1,361	1,529
LG&E	1,348	2,306
LG&E	1,332	1,493
KU	1,312	1,438
KU	1,307	1,729
KU	1,304	1,563
LG&E	1,297	1,547
KU	1,289	1,570
LG&E	1,286	3,733
KU	1,285	1,465
KU	1,259	1,501
KU	1,236	1,401
KU	1,226	1,765
KU	1,196	1,328
KU	1,194	1,339
KU	1,183	1,901
LG&E	1,174	1,459
LG&E	1,172	1,806
LG&E	1,146	1,204
KU	1,136	1,198

23-Month TODS Average and Max Base Demands by Customer (Ranked by Avg)

CC Name	Average of KW/KVA Base Measured	Max of KW/KVA Base Measured
KU	1,132	1,320
KU	1,120	1,636
KU	1,108	1,380
KU	1,100	3,453
LG&E	1,067	1,265
KU	1,059	1,294
KU	1,059	1,437
KU	1,056	1,229
KU	1,055	1,193
KU	1,048	1,204
KU	1,045	1,260
LG&E	1,036	1,608
LG&E	1,025	1,212
KU	1,021	1,639
KU	1,018	1,179
LG&E	1,016	2,879
LG&E	1,000	1,363
LG&E	991	2,409
LG&E	974	1,454
LG&E	955	1,141
KU	950	1,367
KU	945	1,678
KU	943	1,158
LG&E	936	1,468
KU	917	1,014
KU	911	983
LG&E	909	1,120
KU	908	1,774
KU	903	991
KU	902	1,001
KU	902	1,089
KU	901	1,135
LG&E	898	1,201
KU	894	1,626
KU	890	1,340
KU	876	1,046
KU	875	1,039
KU	874	986
KU	873	1,018
LG&E	872	944
LG&E	866	956
KU	863	931
LG&E	860	970
LG&E	852	1,320
KU	846	874
KU	844	898
KU	841	1,002
KU	839	2,050
KU	837	1,051
LG&E	829	1,042
LG&E	828	1,014
KU	826	947
LG&E	825	918
LG&E	808	1,162
LG&E	804	1,181
KU	803	1,076

23-Month TODS Average and Max Base Demands by Customer (Ranked by Avg)

CC Name	Average of KW/KVA Base Measured	Max of KW/KVA Base Measured
LG&E	801	932
KU	801	1,257
LG&E	795	919
KU	788	940
KU	788	1,305
KU	784	973
KU	780	990
LG&E	779	953
KU	776	1,395
LG&E	774	838
KU	773	1,209
LG&E	773	856
LG&E	772	925
KU	769	1,231
KU	768	906
LG&E	767	879
LG&E	766	1,452
LG&E	762	1,307
KU	759	925
LG&E	758	914
LG&E	757	856
KU	749	1,276
KU	748	864
KU	747	935
LG&E	745	943
LG&E	737	912
LG&E	735	754
KU	733	1,040
KU	733	1,131
KU	732	1,718
KU	728	1,133
KU	722	817
LG&E	721	792
KU	721	823
KU	716	849
KU	710	807
KU	709	871
LG&E	704	902
LG&E	700	880
KU	695	799
KU	694	1,054
LG&E	693	829
KU	692	906
KU	692	911
KU	690	730
KU	685	1,193
LG&E	685	805
LG&E	684	1,061
KU	680	864
KU	680	765
KU	675	1,276
LG&E	675	1,187
LG&E	674	877
LG&E	670	1,350
LG&E	666	747
LG&E	665	742

23-Month TODS Average and Max Base Demands by Customer (Ranked by Avg)

CC Name	Average of KW/KVA Base Measured	Max of KW/KVA Base Measured
LG&E	662	816
LG&E	659	745
KU	657	707
KU	655	883
KU	652	859
KU	640	947
LG&E	640	692
LG&E	635	810
LG&E	632	1,091
KU	630	791
LG&E	628	752
KU	627	830
LG&E	625	1,183
KU	622	799
KU	621	746
KU	620	802
KU	615	671
LG&E	611	1,293
KU	607	855
KU	604	720
KU	603	1,164
KU	602	643
LG&E	599	665
KU	594	1,190
LG&E	594	698
KU	593	753
KU	593	726
LG&E	591	791
KU	591	665
KU	588	1,014
KU	588	770
KU	587	758
KU	585	782
LG&E	585	761
LG&E	585	884
LG&E	585	2,080
KU	582	970
KU	580	642
KU	579	744
KU	578	717
LG&E	577	926
LG&E	576	704
KU	575	735
KU	574	722
LG&E	574	634
KU	574	864
KU	571	725
LG&E	570	730
KU	568	761
LG&E	568	593
KU	567	977
KU	563	742
KU	562	708
KU	560	1,850
LG&E	560	716
KU	560	728

23-Month TODS Average and Max Base Demands by Customer (Ranked by Avg)

CC Name	Average of KW/KVA Base Measured	Max of KW/KVA Base Measured
LG&E	559	683
LG&E	557	723
KU	556	1,057
LG&E	556	700
LG&E	555	1,670
KU	554	589
KU	553	586
KU	552	655
KU	552	583
KU	549	1,005
LG&E	548	584
KU	547	684
KU	545	690
KU	543	1,204
LG&E	543	679
LG&E	542	747
KU	542	1,026
LG&E	541	637
KU	540	568
KU	540	722
LG&E	539	662
KU	538	578
LG&E	533	632
KU	532	594
KU	532	595
LG&E	530	722
KU	527	650
KU	525	624
LG&E	521	757
KU	519	629
KU	517	657
KU	516	590
KU	512	570
LG&E	512	707
LG&E	512	659
KU	511	786
KU	510	612
KU	510	922
LG&E	509	611
KU	508	687
LG&E	507	896
KU	507	581
KU	507	630
KU	507	2,041
LG&E	506	607
LG&E	506	892
KU	505	727
KU	503	913
LG&E	500	649
KU	497	525
KU	494	808
LG&E	493	957
LG&E	493	1,005
KU	492	655
KU	492	907
KU	490	639

23-Month TODS Average and Max Base Demands by Customer (Ranked by Avg)

CC Name	Average of KW/KVA Base Measured	Max of KW/KVA Base Measured
LG&E	489	631
LG&E	488	600
KU	487	549
KU	487	709
KU	486	587
KU	485	680
KU	484	601
KU	484	581
LG&E	484	774
KU	484	655
KU	482	543
KU	482	682
LG&E	481	703
KU	481	847
LG&E	481	552
KU	480	544
KU	480	540
KU	479	497
KU	479	559
KU	478	886
KU	477	574
KU	477	726
KU	475	771
KU	474	618
LG&E	474	530
KU	473	602
KU	471	540
KU	470	568
LG&E	469	626
KU	466	776
LG&E	465	622
KU	465	552
KU	465	630
LG&E	465	601
KU	464	499
KU	462	560
LG&E	461	586
LG&E	461	566
KU	460	769
KU	460	611
KU	460	576
LG&E	459	755
KU	458	1,501
KU	458	659
KU	455	839
KU	455	554
LG&E	453	520
KU	452	505
KU	451	928
LG&E	450	549
KU	449	535
KU	448	501
LG&E	448	503
KU	447	531
KU	447	716
KU	447	638

23-Month TODS Average and Max Base Demands by Customer (Ranked by Avg)

CC Name	Average of KW/KVA Base Measured	Max of KW/KVA Base Measured
LG&E	445	658
KU	445	570
KU	443	579
KU	443	859
LG&E	442	539
KU	442	779
LG&E	442	904
LG&E	442	698
LG&E	441	563
LG&E	440	533
KU	440	569
KU	440	521
KU	438	554
KU	438	514
KU	436	468
KU	435	531
KU	434	584
KU	432	536
KU	432	454
KU	432	547
KU	432	845
KU	431	503
KU	431	468
LG&E	431	706
KU	430	570
LG&E	430	663
KU	430	482
KU	428	830
LG&E	427	1,203
LG&E	426	562
KU	426	482
KU	426	515
LG&E	425	467
KU	424	525
KU	423	644
LG&E	423	642
LG&E	421	545
KU	421	697
KU	421	454
KU	421	543
KU	419	526
KU	419	479
LG&E	419	450
KU	418	457
KU	418	519
KU	415	548
KU	415	540
KU	414	483
LG&E	414	513
LG&E	414	550
LG&E	413	492
KU	413	514
KU	412	625
KU	412	653
KU	409	683
KU	409	503

23-Month TODS Average and Max Base Demands by Customer (Ranked by Avg)

CC Name	Average of KW/KVA Base Measured	Max of KW/KVA Base Measured
KU	409	504
KU	408	501
KU	408	440
LG&E	406	483
KU	406	441
KU	404	599
KU	403	498
KU	403	507
LG&E	403	525
KU	402	442
KU	402	503
KU	402	629
KU	401	498
KU	400	498
KU	400	499
KU	399	491
KU	398	539
LG&E	396	396
KU	396	969
LG&E	396	442
KU	394	422
LG&E	394	554
LG&E	393	452
LG&E	391	563
KU	390	500
LG&E	390	467
KU	390	495
KU	389	434
LG&E	389	425
KU	387	453
KU	387	452
LG&E	386	504
KU	386	488
KU	386	462
KU	386	649
KU	386	465
KU	386	437
KU	386	386
KU	385	490
KU	384	533
KU	384	452
KU	384	419
LG&E	384	490
KU	383	583
KU	383	433
LG&E	382	566
KU	382	465
KU	381	688
KU	381	532
KU	381	537
KU	380	399
LG&E	380	436
LG&E	380	1,037
KU	377	506
KU	376	412
KU	376	440

23-Month TODS Average and Max Base Demands by Customer (Ranked by Avg)

CC Name	Average of KW/KVA Base Measured	Max of KW/KVA Base Measured
KU	376	452
LG&E	376	568
KU	375	611
LG&E	375	485
KU	374	472
KU	373	511
KU	372	509
KU	370	575
LG&E	370	439
KU	370	726
KU	368	528
KU	367	496
LG&E	366	470
LG&E	366	478
LG&E	365	432
LG&E	363	417
KU	363	384
KU	363	442
KU	363	532
LG&E	359	653
KU	359	466
LG&E	358	559
KU	358	450
KU	357	511
KU	357	424
LG&E	357	451
KU	356	444
KU	356	423
KU	356	417
KU	355	643
KU	355	697
KU	355	446
LG&E	355	426
KU	354	478
LG&E	354	458
KU	353	422
KU	351	628
KU	351	431
KU	351	622
KU	351	426
LG&E	349	463
KU	348	601
KU	347	427
KU	346	510
LG&E	345	420
KU	345	542
LG&E	344	429
KU	344	419
KU	343	442
KU	343	400
KU	342	376
LG&E	342	358
KU	342	385
LG&E	342	586
KU	342	462
LG&E	342	483

23-Month TODS Average and Max Base Demands by Customer (Ranked by Avg)

CC Name	Average of KW/KVA Base Measured	Max of KW/KVA Base Measured
LG&E	341	491
KU	341	658
LG&E	340	657
KU	340	378
KU	340	520
KU	340	396
KU	339	404
LG&E	338	416
KU	338	350
LG&E	337	454
KU	337	436
LG&E	337	382
LG&E	337	398
LG&E	337	466
KU	336	409
LG&E	336	477
KU	336	367
KU	336	397
KU	336	381
KU	335	419
LG&E	335	412
KU	334	397
KU	334	412
LG&E	334	448
LG&E	334	427
KU	333	411
KU	332	429
KU	331	482
KU	331	396
KU	330	479
KU	330	424
KU	329	452
LG&E	328	410
LG&E	328	381
LG&E	328	662
LG&E	326	698
LG&E	326	350
KU	326	492
KU	325	409
LG&E	325	472
LG&E	324	430
KU	324	406
LG&E	324	416
KU	324	340
KU	324	511
KU	323	385
KU	323	358
KU	322	397
LG&E	322	384
KU	321	470
LG&E	320	511
LG&E	319	368
KU	318	521
KU	318	428
LG&E	317	391
LG&E	316	442

23-Month TODS Average and Max Base Demands by Customer (Ranked by Avg)

CC Name	Average of KW/KVA Base Measured	Max of KW/KVA Base Measured
KU	316	345
LG&E	316	384
LG&E	315	491
KU	315	390
KU	315	499
LG&E	313	361
KU	313	416
LG&E	313	437
KU	313	341
KU	312	378
LG&E	311	476
LG&E	311	358
KU	311	338
KU	311	487
KU	311	704
KU	311	419
KU	311	462
KU	310	408
KU	310	430
KU	310	408
LG&E	310	413
KU	310	376
KU	309	358
LG&E	309	357
LG&E	309	387
KU	308	374
LG&E	308	407
KU	308	479
KU	308	354
KU	308	438
KU	308	408
KU	307	389
LG&E	307	464
KU	307	371
KU	306	330
KU	306	499
KU	306	325
KU	306	423
KU	305	386
LG&E	305	357
KU	305	378
KU	305	374
KU	304	372
LG&E	304	337
KU	303	368
KU	303	350
KU	303	343
LG&E	303	448
KU	302	396
LG&E	302	422
LG&E	302	402
KU	302	412
LG&E	301	338
LG&E	300	421
LG&E	300	355
KU	300	331

23-Month TODS Average and Max Base Demands by Customer (Ranked by Avg)

CC Name	Average of KW/KVA Base Measured	Max of KW/KVA Base Measured
LG&E	300	454
KU	300	391
KU	299	490
LG&E	299	353
KU	299	407
KU	299	299
LG&E	299	331
KU	298	401
LG&E	298	328
KU	297	377
LG&E	297	512
KU	297	382
LG&E	297	387
LG&E	297	393
KU	296	344
LG&E	295	356
KU	295	410
LG&E	295	376
KU	294	337
KU	294	324
LG&E	294	383
LG&E	293	329
KU	293	317
KU	293	385
KU	293	375
KU	293	384
KU	292	393
KU	291	399
KU	291	369
KU	291	409
KU	291	452
LG&E	290	361
LG&E	290	554
LG&E	290	429
KU	290	485
KU	290	462
LG&E	290	352
LG&E	290	391
LG&E	290	373
KU	289	441
KU	289	361
KU	288	406
KU	288	375
KU	288	364
LG&E	287	346
KU	287	317
LG&E	287	351
KU	286	515
LG&E	286	386
KU	285	398
LG&E	285	368
KU	284	516
KU	283	361
LG&E	281	318
KU	280	343
KU	279	334

23-Month TODS Average and Max Base Demands by Customer (Ranked by Avg)

CC Name	Average of KW/KVA Base Measured	Max of KW/KVA Base Measured
KU	279	344
LG&E	279	314
LG&E	278	398
LG&E	278	310
KU	278	412
LG&E	278	354
LG&E	277	346
KU	277	512
KU	277	419
KU	277	321
LG&E	276	344
KU	276	316
KU	276	328
KU	275	390
KU	275	333
KU	275	288
KU	274	452
LG&E	274	284
KU	273	383
LG&E	273	319
KU	273	317
LG&E	273	355
KU	272	320
KU	271	319
LG&E	271	356
KU	271	295
LG&E	270	341
LG&E	270	320
KU	269	390
LG&E	269	326
KU	269	343
KU	269	320
KU	268	542
LG&E	268	626
LG&E	268	395
LG&E	268	314
KU	267	320
LG&E	266	424
KU	266	396
KU	266	311
KU	265	294
KU	265	421
LG&E	265	488
LG&E	265	330
LG&E	265	358
LG&E	264	304
KU	263	354
LG&E	263	302
KU	263	432
KU	263	368
LG&E	263	359
KU	262	368
LG&E	262	301
KU	262	419
LG&E	261	261
KU	261	475

23-Month TODS Average and Max Base Demands by Customer (Ranked by Avg)

CC Name	Average of KW/KVA Base Measured	Max of KW/KVA Base Measured
LG&E	261	444
KU	261	326
LG&E	260	337
KU	259	528
KU	259	370
LG&E	259	307
LG&E	259	290
LG&E	259	433
KU	258	316
KU	258	502
LG&E	258	294
KU	257	324
KU	257	330
KU	256	306
LG&E	255	330
KU	255	354
KU	255	342
LG&E	255	292
LG&E	254	326
KU	254	383
KU	254	519
LG&E	254	938
LG&E	254	281
KU	253	328
KU	253	304
KU	252	295
KU	252	252
KU	251	261
LG&E	251	418
KU	249	305
KU	248	368
LG&E	248	329
LG&E	248	283
KU	247	301
LG&E	247	599
KU	247	265
KU	246	342
KU	246	269
LG&E	245	302
KU	245	292
KU	244	280
KU	244	326
KU	243	371
KU	243	284
KU	242	418
LG&E	242	290
KU	242	306
KU	242	294
LG&E	242	302
KU	242	251
KU	241	340
KU	240	362
KU	238	291
LG&E	238	244
LG&E	238	337
KU	238	270

23-Month TODS Average and Max Base Demands by Customer (Ranked by Avg)

CC Name	Average of KW/KVA Base Measured	Max of KW/KVA Base Measured
LG&E	238	321
LG&E	237	294
KU	237	283
KU	236	289
KU	236	264
LG&E	235	332
LG&E	235	326
KU	235	257
KU	233	259
LG&E	232	258
LG&E	231	303
KU	229	304
LG&E	229	274
KU	229	286
KU	227	406
KU	227	295
KU	226	331
KU	226	330
LG&E	225	259
KU	225	269
KU	224	513
LG&E	223	256
KU	215	372
LG&E	215	215
KU	214	291
LG&E	214	220
LG&E	213	262
KU	210	288
LG&E	209	437
KU	209	404
KU	208	339
KU	207	261
LG&E	205	307
KU	204	243
LG&E	204	231
KU	203	412
KU	200	273
LG&E	200	205
KU	200	465
KU	200	306
LG&E	199	214
LG&E	197	218
LG&E	195	231
LG&E	194	198
LG&E	193	287
KU	189	338
LG&E	188	205
KU	188	213
KU	186	330
LG&E	185	243
KU	183	739
LG&E	180	187
LG&E	178	221
KU	178	244
LG&E	178	232
LG&E	176	176

23-Month TODS Average and Max Base Demands by Customer (Ranked by Avg)

CC Name	Average of KW/KVA Base Measured	Max of KW/KVA Base Measured
KU	175	202
KU	175	312
LG&E	173	184
LG&E	171	240
LG&E	170	286
KU	166	193
KU	166	173
KU	165	218
KU	164	467
KU	163	164
KU	155	251
KU	154	224
KU	153	440
KU	153	167
LG&E	152	327
LG&E	151	192
LG&E	148	167
KU	146	528
KU	144	177
KU	137	143
KU	135	135
LG&E	133	135
LG&E	133	237
KU	133	182
LG&E	132	278
KU	132	248
LG&E	130	151
KU	128	159
LG&E	127	211
LG&E	126	147
KU	125	144
KU	123	147
KU	120	193
KU	120	162
KU	120	155
LG&E	116	232
KU	111	174
LG&E	110	142
LG&E	106	131
KU	106	200
LG&E	103	161
KU	102	216
KU	102	255
KU	99	137
LG&E	98	262
LG&E	98	156
KU	97	246
KU	97	424
KU	87	180
LG&E	86	120
KU	86	142
KU	84	107
KU	83	109
LG&E	82	114
LG&E	82	106
KU	80	97

23-Month TODS Average and Max Base Demands by Customer (Ranked by Avg)

CC Name	Average of KW/KVA Base Measured	Max of KW/KVA Base Measured
KU	80	218
LG&E	77	174
KU	74	108
KU	71	173
LG&E	68	96
KU	65	127
LG&E	61	289
KU	56	86
LG&E	51	116
KU	45	60
KU	45	123
KU	39	66
LG&E	38	106
KU	36	96
KU	30	52
LG&E	30	46
LG&E	26	26
KU	26	36
KU	24	39
KU	23	23
KU	23	262
KU	19	48
KU	19	19
KU	6	6
KU	4	4

LOUISVILLE GAS AND ELECTRIC COMPANY

**Response to First Request for Information of the
Louisville/Jefferson County Metro Government
Dated November 13, 2018**

Case No. 2018-00295

Question No. 2

Responding Witness: William Steven Seelye

- Q-2. Regarding rate TOD-S, please confirm that revenue related to Base Demand is not expected to vary (in aggregate) because the reduction in the base rate is offset by the determination of load using kVA in the forecast model.
- A-2. Confirmed. The impact of using kVA is revenue neutral.

LOUISVILLE GAS AND ELECTRIC COMPANY**Response to First Request for Information of the
Louisville/Jefferson County Metro Government
Dated November 13, 2018****Case No. 2018-00295****Question No. 3****Responding Witness: John K. Wolfe**

- Q-3. Please provide the number (quantity), rate type, type description, and location (by street address) of each street light located in Jefferson County, Kentucky for which Louisville Metro currently pays rates to the Company.
- A-3. See attachment being provided in Excel format for location by street address; number, rate type, and description.

LOUISVILLE METRO STREET LIGHT BILLING

Bill Code: Description	Quantity
RLS 201: OH MV Open Bottom 4000L Fixture	2
RLS 203: OH MV Cobra Head 13000L Fixture	1586
RLS 204: OH MV Cobra Head 25000L Fixture	2256
RLS 206: UG MV Coach 4000L Decorative	11
RLS 207: OH MV Directional 25000L Fix	29
RLS 208: UG MV Coach 8000L Decorative	357
RLS 209: OH MV Cobra Head 60000L Fixture	1
RLS 210: OH MV Directional 60000L Fix	7
RLS 252: OH MV Cobra/Open Bottom 8000L	951
RLS 266: UG HPS Cobra/Contemp 28500L	1322
RLS 267: UG HPS Cobra/Contemp 50000L	472
RLS 274: UG HPS Coach/Acorn 9500L Deco	603
RLS 275: UG HPS Cobra/Contemp 16000L	82
RLS 276: UG HPS Coach/Acorn 5800L Deco	43
RLS 277: UG HPS Coach/Acorn 16000L Deco	251
RLS 314: UG MV Cobra Head 13000L Deco	367
RLS 315: UG MV Cobra Head 25000L Deco	413
RLS 318: UG MV Cobra Head 8000L Deco	42
RLS 348: UG Inc Continental Jr 6000L Dec	39

RLS 349: UG Inc Continental Jr 1500L Dec	16
LS 413: UG HPS Colonial 4-Sided 9500L	86
LS 416: UG HPS Acorn 9500L Decorative	3
LS 420: UG HPS Contemporary 16000L Deco	11
LS 421: UG HPS Contemporary 28500L Deco	6
LS 422: UG HPS Contemporary 50000L Deco	7
LS 423: UG HPS Cobra Head 16000L Deco	16
LS 424: UG HPS Cobra Head 28500L Deco	670
LS 425: UG HPS Cobra Head 50000L Deco	9
LS 427: UG HPS London 5800L Historic	2
RLS 430: UG HPS Victorian 5800L Deco	12
LS 433: UG HPS Victorian 9500L Historic	3
LS 445: UG HPS Acorn 16000L Decorative	15
LS 452: OH HPS Cobra Head 16000L Fixture	3733
LS 453: OH HPS Cobra Head 28500L Fixture	8595
LS 454: OH HPS Cobra Head 50000L Fixture	1993
LS 455: OH HPS Directional 16000L Fix	7
LS 456: OH HPS Directional 50000L Fix	298
LS 457: OH HPS Open Bottom 9500L Fixture	23
LS 473: OH MH Directional 32000L Fixture	2
LS 490: OH LED Cobra Head 8179L Fixture	5
LS 491: OH LED Cobra Head 14166L Fixture	7
LS 493: OH LED Open Bottom 5007L Fixture	44
Total	24,397

The attachment is being provided in a separate file in Excel format.

LOUISVILLE GAS AND ELECTRIC COMPANY

**Response to First Request for Information of the
Louisville/Jefferson County Metro Government
Dated November 13, 2018**

Case No. 2018-00295

Question No. 4

Responding Witness: William Steven Seelye

Q-4. Please refer to Exhibit WSS-4:

- a. On Page 1, please provide a comprehensive breakdown of the Total Installed Cost for each LED lighting offering.
- b. Please explain how LG&E or Mr. Seelye calculated the Fixed Carrying Charge.
- c. Please explain the justification for the Fixed Carrying Charge.
- d. Please provide all workpapers supporting the estimated investment per unit for each type of LED fixture and underground pole.

A-4.

- a. See the response to PSC 2-29, part a.
- b. See the response to PSC 2-29, part b.
- c. The fixed carrying charge contains each component of revenue requirement and is necessary to calculate the annual revenue requirement for each light type.
- d. See the response to part a.

LOUISVILLE GAS AND ELECTRIC COMPANY

**Response to First Request for Information of the
Louisville/Jefferson County Metro Government
Dated November 13, 2018**

Case No. 2018-00295

Question No. 5

Responding Witness: Robert M. Conroy

- Q-5. Please refer to the paragraph 4.5 of the First Stipulation and Recommendation entered into in Case Nos. 2016-00370 and 2016-00371.
- a. Please provide copies of all documents/memoranda, emails, minutes of meetings, conclusions, and notices to members prepared by the Companies in conjunction with the LED collaborative.
 - b. Please provide the conclusions and/or recommendations of the collaborative.
 - c. Please provide in detail how the Companies “engage[d] in good faith” during the time that the collaborative existed.
 - d. How many meetings were held? For each meeting, please provide the dates and locations, and results or conclusions.
- A-5. The Company assumes the reference to paragraph 4.5 in the question is actually a reference to paragraph 5.5 in the First Stipulation and Recommendation.
- a. See attached. Certain information requested is confidential and proprietary and is being provided under seal pursuant to a petition for confidential protection.
 - b. Over the course of the three Collaborative Meetings, various needs and concerns were documented. Discussions ranged from the Companies’ pricing model approaches to the potential use of smart networks’ lighting controls’ integration with AMS metering. The recurring themes centered on LED conversion options, LED sizes and fixture types, and LED pricing.

Furthermore the Companies followed up on the Collaborative’s recommendations as proven in the proposed lighting tariffs: Manufacturers have lowered LED pricing and improved LED service lives thereby moving the Companies to lower LED tariffs. Moreover new LED sizes and styles are being

offered that will more closely mimic the current in-service HID fixtures as well as match those styles suggested by the Collaborative.

- c. The Companies fully complied. Over the course of four months the Companies conducted three Collaborative Meetings. The Companies engaged the Collaborative to discuss issues related to LED lighting to determine what LED street lighting equipment and rate structures might be offered by the Companies in the future.

During the sessions the needs and concerns of the Collaborative were well documented. The Collaborative expressed concern that the current LED tariffed prices are higher than particular high intensity discharge (“HID”) fixtures that the Companies currently install throughout the service territories. Challenges were discussed such as the capital structures and energy use, but also the true service life and appropriate operation and maintenance expenses associated with LED’s. The Collaborative also suggested that LED selections could be efficiently expanded with potentially more distinct fixtures while reducing the overall number of fixtures. Furthermore the Collaborative challenged continual one-off HID replacements while signifying a desire for future mass LED replacements of entire street lighting systems.

- d. Three meetings were held. The dates were December 8, 2017; February 23, 2018; March 23, 2018. All meetings were held in Frankfort, Kentucky. See the response to part a.

Reinert, Marty

From: Sturgeon, Allyson
Sent: Friday, November 03, 2017 8:31 AM
To:

[Redacted]

Cc: 'Riggs, Kendrick R.'; Judd, Sara; Conroy, Robert; Lovekamp, Rick; Reinert, Marty
Subject: LED Lighting Collaborative

Good Morning –

On June 22, 2017, the Kentucky Public Service Commission issued orders in LG&E’s and KU’s rate cases approving that portion of the Parties’ Stipulation and Recommendation relating to the establishment of an LED lighting collaborative. We are proposing to hold the initial meeting of the LED lighting collaborative on Friday December 8, 2017 at the Frankfort Holiday Inn Express (1000 Vandalay Drive, Frankfort, KY 40601), beginning at 1 pm.

Response Requested: The Companies request any party to these proceedings to contact me by **November 20, 2017**, to advise of their interest in participating in the collaborative.

Please indicate if you plan to:

- A. Fully participate in the meetings
- B. Do not plan to participate in meetings but would like to receive the meeting presentations and minutes
- C. Have no interest in participating in the LED lighting collaborative

For those who plan to fully participate in the meetings, please provide the name(s) and title(s) of those who plan to be at the meeting, along with their phone number(s) and email address(es). We will forward meeting details to all identified meeting participants as soon as this information is finalized.

We look forward to working with you on this initiative. Thanks, Allyson

Reinert, Marty

From: Sturgeon, Allyson
Sent: Tuesday, November 07, 2017 2:42 PM
To: Reinert, Marty
Subject: FW: LED collaborative and electric bus collaborative

Allyson K. Sturgeon
LG&E and KU Energy LLC

From: Cathy Hinko [REDACTED]
Sent: Tuesday, November 07, 2017 2:41 PM
To: Sturgeon, Allyson
Subject: LED collaborative and electric bus collaborative

EXTERNAL email. STOP and THINK before responding, clicking on links, or opening attachments.

Allyson

Given MHC's resources, we are not going to be able to actively participate in the two collaboratives- LED and electric bus. We certainly recognize the importance of each and would like to be kept in the loop. As Tom Fitzgerald is MHC's attorney, can you keep both him and me on the e-mail distribution list and informed about what is going on?

Thank you.

Cathy

Cathy Hinko
Executive Director
Metropolitan Housing Coalition

[REDACTED]

Reinert, Marty

From: Sturgeon, Allyson
Sent: Friday, November 03, 2017 2:17 PM
To: Conroy, Robert; Reinert, Marty; Lovekamp, Rick
Subject: FW: LED Lighting Collaborative

FYI

Allyson K. Sturgeon
LG&E and KU Energy LLC

From: Dennis Howard II [REDACTED]
Sent: Friday, November 03, 2017 9:13 AM
To: Sturgeon, Allyson
Subject: RE: LED Lighting Collaborative

EXTERNAL email. STOP and THINK before responding, clicking on links, or opening attachments.

Allyson

I have no interest in participating. Thank you.

Cordially,

Dennis G. Howard, II
Howard Law PLLC

This e-mail transmission (including any documents or files accompanying it) may contain confidential information which is protected by the attorney-client and work product privileges. It is intended only for the use of the recipients named above. If you are not an intended recipient, please (1) do not read, copy or retransmit this communication, (2) delete it immediately, and (3) notify me promptly. Any unauthorized dissemination, distribution or copying of this communication is strictly prohibited.

From: Sturgeon, Allyson [REDACTED]
Sent: Friday, November 03, 2017 8:31 AM
To: [REDACTED]

[REDACTED]

Conroy

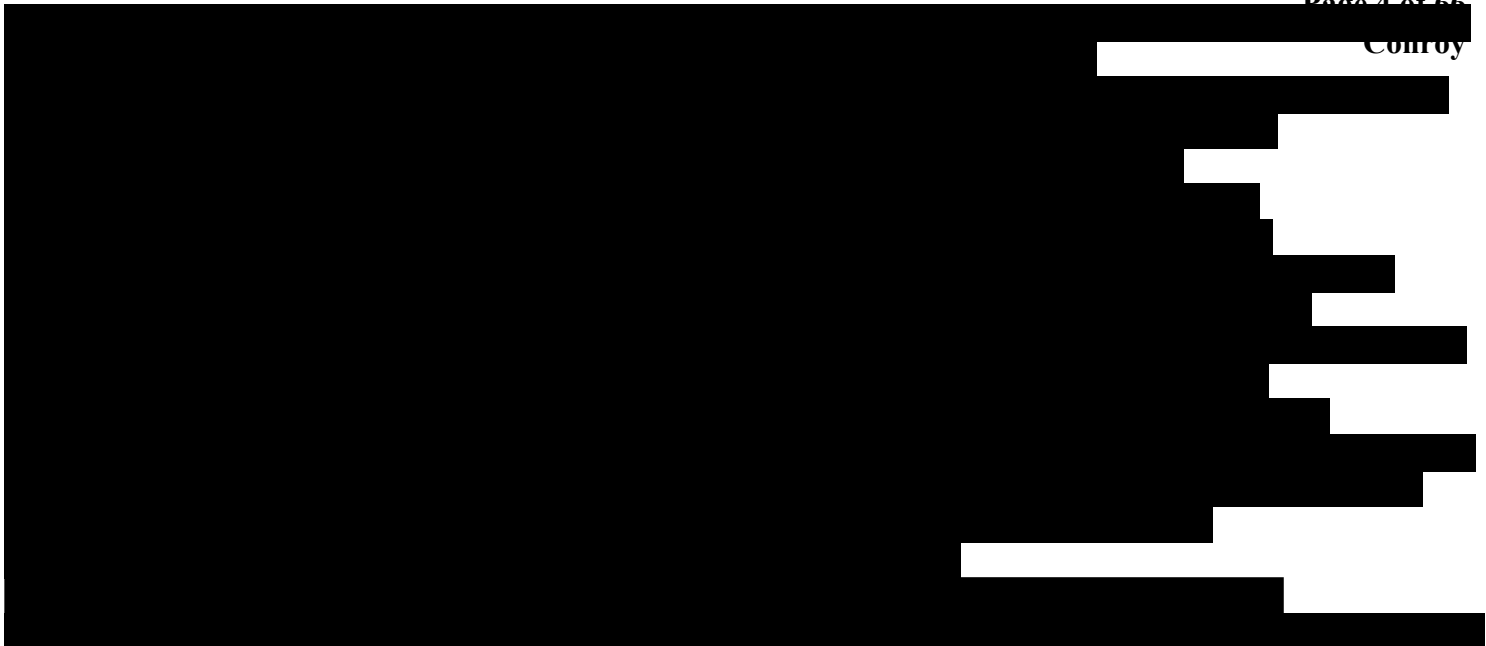

Subject: LED Lighting Collaborative

Good Morning –

On June 22, 2017, the Kentucky Public Service Commission issued orders in LG&E’s and KU’s rate cases approving that portion of the Parties’ Stipulation and Recommendation relating to the establishment of an LED lighting collaborative. We are proposing to hold the initial meeting of the LED lighting collaborative on Friday December 8, 2017 at the Frankfort Holiday Inn Express (1000 Vandalay Drive, Frankfort, KY 40601), beginning at 1 pm.

Response Requested: The Companies request any party to these proceedings to contact me by **November 20, 2017**, to advise of their interest in participating in the collaborative.

Please indicate if you plan to:

- A. Fully participate in the meetings
- B. Do not plan to participate in meetings but would like to receive the meeting presentations and minutes
- C. Have no interest in participating in the LED lighting collaborative

For those who plan to fully participate in the meetings, please provide the name(s) and title(s) of those who plan to be at the meeting, along with their phone number(s) and email address(es). We will forward meeting details to all identified meeting participants as soon as this information is finalized.

We look forward to working with you on this initiative. Thanks, Allyson

----- The information contained in this transmission is intended only for the person or entity to which it is directly addressed or copied. It may contain material of confidential and/or private nature. Any review, retransmission, dissemination or other use of, or taking of any action in reliance upon, this information by persons or entities other than the intended recipient is not allowed. If you received this message and the information contained therein by error, please contact the sender and delete the material from your/any storage medium.

Reinert, Marty

From: Sturgeon, Allyson
Sent: Monday, November 06, 2017 12:23 PM
To: Conroy, Robert; Lovekamp, Rick; Reinert, Marty
Subject: FW: LED Lighting Collaborative

Allyson K. Sturgeon
LG&E and KU Energy LLC
[REDACTED]

-----Original Message-----

From: Medlyn, Emily W [REDACTED]
Sent: Monday, November 06, 2017 12:19 PM
To: Sturgeon, Allyson [REDACTED]
Subject: RE: LED Lighting Collaborative

EXTERNAL email. STOP and THINK before responding, clicking on links, or opening attachments.

Good afternoon Allyson,

DoD/FEA does not have an interest in participating in the LED collaborative at this time (option C). Thank you for your email.

Kind regards,

Emily

Emily W. Medlyn
General Attorney
U. S. Army Legal Services Agency
Regulatory Law and Intellectual Property Division
[REDACTED]

This email is for the intended recipient only and may contain confidential and privileged information, including attorney-client privileged information and information protected by the attorney work product doctrine. No one other than the intended recipient may read, print, store, copy, forward, or act in reliance on this e-mail or its attachments. If you are not the intended recipient of this e-mail, please return the message to the sender, delete the message and any attachments from your computer, and do not retain any type of copy whatsoever of the message or any attachment.

-----Original Message-----

From: Sturgeon, Allyson [REDACTED]

Sent: Friday, November 03, 2017 8:31 AM

To: [REDACTED]

[REDACTED]

Subject: [Non-DoD Source] LED Lighting Collaborative

Good Morning -

On June 22, 2017, the Kentucky Public Service Commission issued orders in LG&E's and KU's rate cases approving that portion of the Parties' Stipulation and Recommendation relating to the establishment of an LED lighting collaborative. We are proposing to hold the initial meeting of the LED lighting collaborative on Friday December 8, 2017 at the Frankfort Holiday Inn Express (1000 Vandalay Drive, Frankfort, KY 40601), beginning at 1 pm.

Response Requested: The Companies request any party to these proceedings to contact me by November 20, 2017, to advise of their interest in participating in the collaborative.

Please indicate if you plan to:

- A. Fully participate in the meetings
- B. Do not plan to participate in meetings but would like to receive the meeting presentations and minutes
- C. Have no interest in participating in the LED lighting collaborative

For those who plan to fully participate in the meetings, please provide the name(s) and title(s) of those who plan to be at the meeting, along with their phone number(s) and email address(es). We will forward meeting details to all identified meeting participants as soon as this information is finalized.

We look forward to working with you on this initiative. Thanks, Allyson

----- The information contained in this transmission is intended only for the person or entity to which it is directly addressed or copied. It may contain material of confidential and/or private nature. Any review, retransmission, dissemination or other use of, or taking of any action in reliance upon, this information by persons or entities other than the intended recipient is not allowed. If you received this message and the information contained therein by error, please contact the sender and delete the material from your/any storage medium.

Reinert, Marty

From: Sturgeon, Allyson
Sent: Tuesday, November 14, 2017 3:20 PM
To: Reinert, Marty
Subject: FW: LED Lighting Collaborative

Allyson K. Sturgeon
LG&E and KU Energy LLC

From: James Bush [REDACTED]
Sent: Tuesday, November 14, 2017 2:12 PM
To: Sturgeon, Allyson
Cc: David Barberie ; Richard Dugas ; Jeffrey Neal ; Dowell Hoskins-Squier
Subject: RE: LED Lighting Collaborative

EXTERNAL email. STOP and THINK before responding, clicking on links, or opening attachments.
Allyson, please add the following to your distribution list. We plan to fully participate.

James Bush, Program Manager, [REDACTED]
Richard Dugas, Program Manager, [REDACTED] [v](#)
Jeff Neal, Director, [REDACTED]

James Bush
Program Manager, Energy Initiatives
Division of Environmental Services



From: Sturgeon, Allyson [REDACTED]
Sent: Friday, November 03, 2017 8:31 AM
To: [REDACTED]

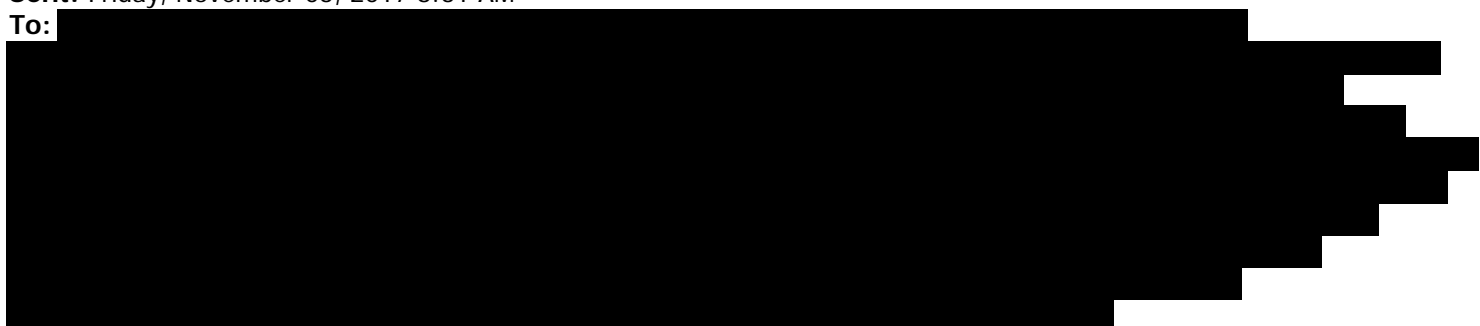

Cc: 'Riggs, Kendrick R.'; Judd, Sara; Conroy, Robert; Lovekamp, Rick; Reinert, Marty
Subject: LED Lighting Collaborative

[EXTERNAL] Use caution before clicking links and/or opening attachments.

Good Morning –

On June 22, 2017, the Kentucky Public Service Commission issued orders in LG&E's and KU's rate cases approving that portion of the Parties' Stipulation and Recommendation relating to the establishment of an LED lighting collaborative. We are proposing to hold the initial meeting of the LED lighting collaborative on Friday December 8, 2017 at the Frankfort Holiday Inn Express (1000 Vandalay Drive, Frankfort, KY 40601), beginning at 1 pm.

Response Requested: The Companies request any party to these proceedings to contact me by **November 20, 2017**, to advise of their interest in participating in the collaborative.

Please indicate if you plan to:

- A. Fully participate in the meetings
- B. Do not plan to participate in meetings but would like to receive the meeting presentations and minutes
- C. Have no interest in participating in the LED lighting collaborative

For those who plan to fully participate in the meetings, please provide the name(s) and title(s) of those who plan to be at the meeting, along with their phone number(s) and email address(es). We will forward meeting details to all identified meeting participants as soon as this information is finalized.

We look forward to working with you on this initiative. Thanks, Allyson

----- The information contained in this transmission is intended only for the person or entity to which it is directly addressed or copied. It may contain material of confidential and/or private nature. Any review, retransmission, dissemination or other use of, or taking of any action in reliance upon, this information by persons or entities other than the intended recipient is not allowed. If you received this message and the information contained therein by error, please contact the sender and delete the material from your/any storage medium.

Reinert, Marty

From: Sturgeon, Allyson
Sent: Monday, November 06, 2017 9:37 AM
To: Conroy, Robert; Reinert, Marty; Lovekamp, Rick
Subject: FW: LED Lighting Collaborative

FYI

Allyson K. Sturgeon
LG&E and KU Energy LLC

From: Derouen, Jeff [REDACTED]
Sent: Monday, November 06, 2017 9:33 AM
To: Sturgeon, Allyson
Cc: Johnson, Pat W ; Keith, Stacy ; Andrews, Al J. ; Bradley, Maxwell B. ; Tipton, Benjamin K. ; Gregory Dutton
Subject: FW: LED Lighting Collaborative

EXTERNAL email. STOP and THINK before responding, clicking on links, or opening attachments.

Allyson,

Louisville Metro Government is submitting five people, three from Public Works and two from Office of Management and Budget. They are cc'd above. Please send information directly with them. I don't think all five can come to every event, but Louisville Metro Government should be able to have someone at most.

The members are:

Pat Johnson, Public Works
[REDACTED]

Stacy Keith, Public Works
[REDACTED]

Al Andrews, Public Works
[REDACTED]

Max Bradley, OMB Financial Administrator for PWA
[REDACTED]

Ben Tipton, OMB Budget Analyst
[REDACTED]

JEFF DEROUEN

OFFICE OF MIKE O'CONNELL
JEFFERSON COUNTY ATTORNEY

[REDACTED]



From: "Sturgeon, Allyson" [Redacted]
Date: November 3, 2017 at 8:31:09 AM EDT
To: "**Subject: LED Lighting Collaborative**"

Good Morning –

On June 22, 2017, the Kentucky Public Service Commission issued orders in LG&E's and KU's rate cases approving that portion of the Parties' Stipulation and Recommendation relating to the establishment of an LED lighting collaborative. We are proposing to hold the initial meeting of the LED lighting collaborative on Friday December 8, 2017 at the Frankfort Holiday Inn Express (1000 Vandalay Drive, Frankfort, KY 40601), beginning at 1 pm.

Response Requested: The Companies request any party to these proceedings to contact me by **November 20, 2017**, to advise of their interest in participating in the collaborative.

Please indicate if you plan to:

- A. Fully participate in the meetings
- B. Do not plan to participate in meetings but would like to receive the meeting presentations and minutes
- C. Have no interest in participating in the LED lighting collaborative

For those who plan to fully participate in the meetings, please provide the name(s) and title(s) of those who plan to be at the meeting, along with their phone number(s) and email address(es). We will forward meeting details to all identified meeting participants as soon as this information is finalized.

We look forward to working with you on this initiative. Thanks, Allyson

----- The information contained in this transmission is intended only for the person or entity to which it is directly addressed or copied. It may contain material of confidential and/or private nature. Any review, retransmission, dissemination or other use of, or taking of any action in reliance upon, this information by persons or entities other than the intended recipient is not allowed. If you received this message and the information contained therein by error, please contact the sender and delete the material from your/any storage medium.

The information contained in this communication from the sender is confidential. It is intended solely for use by the recipient and others authorized to receive it. If you are not the recipient, you are hereby notified that any disclosure, copying, distribution or taking action in relation of the contents of this information is strictly prohibited and may be unlawful.

Reinert, Marty

From: Sturgeon, Allyson
Sent: Tuesday, November 14, 2017 10:59 AM
To: Reinert, Marty; Lovekamp, Rick; Conroy, Robert
Cc: Judd, Sara
Subject: FW: LED Lighting Collaborative

Allyson K. Sturgeon
LG&E and KU Energy LLC

From: Nipple, Jon - KSBA [REDACTED]
Sent: Tuesday, November 14, 2017 9:13 AM
To: Sturgeon, Allyson
Cc: Willhite, Ron - KSBA
Subject: LED Lighting Collaborative

EXTERNAL email. STOP and THINK before responding, clicking on links, or opening attachments.

Allyson,
I will be participating in these meetings. My title and contact information are below.
Thanks,
Jon

Jon Nipple, CEM
Project Manager
School Energy Managers Project

Kentucky School Boards Association

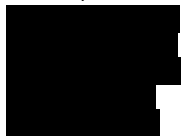

Reinert, Marty

From: Sturgeon, Allyson
Sent: Tuesday, November 14, 2017 11:42 AM
To: Reinert, Marty; Lovekamp, Rick; Conroy, Robert; Judd, Sara
Subject: Fwd: LED Lighting Collaborative

Sent from my iPhone

Begin forwarded message:

From: "Stump, Kenya (EEC)" [REDACTED]
Date: November 14, 2017 at 11:40:40 AM EST
To: "Sturgeon, Allyson" [REDACTED]
Cc: "Bender, Rick (EEC)" [REDACTED] "Wilson, Karen (EEC)" [REDACTED]
Subject: RE: LED Lighting Collaborative

EXTERNAL email. STOP and THINK before responding, clicking on links, or opening attachments.

Allyson:

Our office plans to participate as an observer and as a source of technical assistance during the process.

Here are the names of those participating from our office:

Rick Bender, Executive Adviser [REDACTED]
Kenya Stump, Assistance Director, [REDACTED]
Kenya Stump
Assistant Director, Renewable Energy
[Kentucky Energy and Environment Cabinet](#)



"In order to be irreplaceable, one must always be different."

— Coco Chanel



Register Now!

**2017 GOVERNOR'S CONFERENCE
ON ENERGY AND THE ENVIRONMENT**



From: Sturgeon, Allyson [REDACTED]
Sent: Friday, November 03, 2017 8:31 AM
To: [REDACTED]

[REDACTED]

Cc: 'Riggs, Kendrick R.'; Judd, Sara; Conroy, Robert; Lovekamp, Rick; Reinert, Marty

Subject: LED Lighting Collaborative

Good Morning –

On June 22, 2017, the Kentucky Public Service Commission issued orders in LG&E's and KU's rate cases approving that portion of the Parties' Stipulation and Recommendation relating to the establishment of an LED lighting collaborative. We are proposing to hold the initial meeting of the LED lighting collaborative on Friday December 8, 2017 at the Frankfort Holiday Inn Express (1000 Vandalay Drive, Frankfort, KY 40601), beginning at 1 pm.

Response Requested: The Companies request any party to these proceedings to contact me by **November 20, 2017**, to advise of their interest in participating in the collaborative.

Please indicate if you plan to:

- A. Fully participate in the meetings
- B. Do not plan to participate in meetings but would like to receive the meeting presentations and minutes
- C. Have no interest in participating in the LED lighting collaborative

For those who plan to fully participate in the meetings, please provide the name(s) and title(s) of those who plan to be at the meeting, along with their phone number(s) and email address(es). We will forward meeting details to all identified meeting participants as soon as this information is finalized.

We look forward to working with you on this initiative. Thanks, Allyson

----- The information contained in this transmission is intended only for the person or entity to which it is directly addressed or copied. It may contain material of confidential and/or private nature. Any review, retransmission, dissemination or other use of, or taking of any action in reliance upon, this information by persons or entities other than the intended recipient is not allowed. If you received this message and the information contained therein by error, please contact the sender and delete the material from your/any storage medium.

Reinert, Marty

From: Sturgeon, Allyson
Sent: Monday, November 27, 2017 9:51 AM
To: Lovekamp, Rick; Reinert, Marty
Cc: Conroy, Robert
Subject: FW: Lighting Collaborative

FYI

Allyson K. Sturgeon
LG&E and KU Energy LLC

From: Willhite, Ron - KSBA [REDACTED]
Sent: Monday, November 27, 2017 9:10 AM
To: Sturgeon, Allyson
Cc: McClanahan, Jim
Subject: Lighting Collaborative

EXTERNAL email. STOP and THINK before responding, clicking on links, or opening attachments.

Good morning Allyson,

Jim McClanahan will be attending the first Lighting Collaborative meeting as Jon Nipple who had planned to attend is out from a recent fall that is requiring surgery to repair a leg break.

Thanks,

Ron Willhite - CEM
Director School Energy Managers Project
Kentucky School Boards Association

[REDACTED]

[REDACTED]

This e-mail transmission (including any documents or files accompanying it) may contain confidential information which is protected by the attorney-client and work product privileges. It is intended only for the use of the recipients named above. If you are not an intended recipient, please (1) do not read, copy or retransmit this communication, (2) delete it immediately, and (3) notify me promptly. Any unauthorized dissemination, distribution or copying of this communication is strictly prohibited.

Reinert, Marty

From: Stump, Kenya (EEC) [REDACTED]
Sent: Tuesday, October 17, 2017 10:22 AM
To: Reinert, Marty
Subject: RE: Transportation Conference Center

EXTERNAL email. STOP and THINK before responding, clicking on links, or opening attachments.

Marty:

I am sorry but our training space is not open to outside parties for events unless the event is sponsored by one of the agencies in our building.

Let me know if you need assistance in identifying other locations in Frankfort.

Kenya Stump

Assistant Director, Renewable Energy

[Kentucky Energy and Environment Cabinet](#)

["In order to be irreplaceable, one must always be different."](#)

— Coco Chanel



Register Now!

2017 GOVERNOR'S CONFERENCE

ON ENERGY AND THE ENVIRONMENT



From: Reinert, Marty [REDACTED]

Sent: Tuesday, October 17, 2017 9:07 AM

To: Stump, Kenya (EEC)

Subject: RE: Transportation Conference Center

You are very welcome! And thanks for the info.!

Marty J. Reinert

Sr. Rate & Regulatory Analyst | State Regulation & Rates | LG&E and KU Energy LLC

From: Stump, Kenya (EEC) [REDACTED]

Sent: Tuesday, October 17, 2017 9:02 AM

To: Reinert, Marty [REDACTED]

Subject: Transportation Conference Center

EXTERNAL email. STOP and THINK before responding, clicking on links, or opening attachments.

Marty:

Thanks for reaching out. Here is the link over to Transportation Conference Center

<http://transportation.ky.gov/Conference-Center/Pages/default.aspx>

Kenya Stump
Assistant Director, Renewable Energy
[Kentucky Energy and Environment Cabinet](#)



["In order to be irreplaceable, one must always be different."](#)

— Coco Chanel



Register Now!

**2017 GOVERNOR'S CONFERENCE
ON ENERGY AND THE ENVIRONMENT**



----- The information contained in this transmission is intended only for the person or entity to which it is directly addressed or copied. It may contain material of confidential and/or private nature. Any review, retransmission, dissemination or other use of, or taking of any action in reliance upon, this information by persons or entities other than the intended recipient is not allowed. If you received this message and the information contained therein by error, please contact the sender and delete the material from your/any storage medium.

COLLABORATIVE MEETING #1

Reinert, Marty

From: Reinert, Marty
Sent: Wednesday, December 06, 2017 11:50 AM
Cc: Sturgeon, Allyson; Judd, Sara
Subject: LED Collaborative reminder

Hello!

This is a reminder that the initial LED lighting collaborative session is this Friday December 8, 2017 at 1:00 pm at the Frankfort, Kentucky Holiday Inn Express (1000 Vandalay Drive).

If you have any questions please do not hesitate to contact me.

Thanks!

Marty J. Reinert

Sr. Rate & Regulatory Analyst | State Regulation & Rates | LG&E and KU Energy LLC



LED Collaborative

Friday December 8, 2017

Holiday Inn Express

1000 Vandalay Drive Frankfort, KY 40601

1:00pm-5:00pm

Table #	Attending	Name	Organization	Telephone	Email
1	✓	Pat Johnson	Metro Louisville		
2		Stacy Keith	Metro Louisville		
3		Al Andrews	Metro Louisville		
1		Max Bradley	Metro Louisville		
2	✓	Jim McClanahan	KSBA		
3		Ben Tipton	Metro Louisville		
1	✓	James Bush	Lexington		
2	✓	Richard Dugas	Lexington		
3	✓	Jeff Neal	Lexington		
1	✓	Kenya Stump	DEDI		
2	✓	Rick Bender	DEDI		
3		Kent Chandler	Attorney General		

LED COLLABORATIVE



December 8, 2018



LED Collaborative Company Attendees

- Brad Hayes – Electric Distribution Operations
- Sara Judd - Legal
- Robbie Trimble – Electric Distribution Operations
- Marty Reinert – State Regulation & Rates
- Curtis Warren – Customer Services

LED Collaborative External Attendees

- Lexington-Fayette Urban County Government
 - James Bush, Richard Dugas, Jeff Neal
- Louisville Metro Government
 - Pat Johnson, Stacy Keith, Al Andrews, Max Bradley, Ben Tipton
- KY Dept. of Energy Development and Independence
 - Kenya Stump, Rick Bender
- KY Attorney General
- KY School Board Association
 - Jim McClanahan

LED Collaborative Goal

To engage in good faith to discuss issues related to LED lighting to determine what LED street lighting equipment and rate structures might be offered by KU/LGE

Reinert, Marty

From: Reinert, Marty
Sent: Thursday, January 18, 2018 5:49 PM
Cc: Judd, Sara; Sturgeon, Allyson
Subject: LED Collaborative summary and future LED Collaborative meetings
Attachments: Frankfort 12-8-17 meeting summary .docx

Importance: High

On Friday December 8, 2017 LG&E/KU held the initial LED Lighting Collaborative Meeting at the Holiday Inn Express in Frankfort, KY. Attached please find the summary of the meeting.

The Companies propose to schedule Meeting #2 and #3 again at the Frankfort Holiday Inn Express.

Meeting #2 will be Friday February 23 at 1:00 pm.

Meeting #3 will be Friday March 23 at 9:00 am.

For those planning to participate please respond directly to me.

Thanks!

Marty J. Reinert

Sr. Rate & Regulatory Analyst | State Regulation & Rates | LG&E and KU Energy LLC



Summary of Intervenor Needs/Concerns

12/8/2017 LED Collaborative Meeting

Frankfort, KY

1) LED Costs

- Collaborative participants stated that LED tariffs are priced too high especially when compared to current high intensity discharge lighting (HID) tariffs
 - Collaborative participants suggest Companies should change Rate Methodology because:
 - Energy consumption should be closer to 4,280 hours per year
 - Collaborative participants believe lights are paid for in 5 years
 - LED Energy consumption is lower
 - Operation and Maintenance cost assumptions
 - Collaborative participants suggest to adjust 13 year failure rate to match actual failure rate and true-up actual O&M spend every year
 - Only charge for rolling a truck when you roll a truck
 - Is collected (but not spent) lighting O&M actually spent on non-lighting O&M?
 - What are Companies' costs on maintaining fully depreciated lights?
 - What are Companies' planned LED remove and replace strategy? Replace at 70%, 50%, 40%?
Or wait until customer contacts companies?
 - Possibly only replacing the driver since it fails first

2) LED Fixture Options

- What was LG&E/KU methodology?
 - Collaborative participants desire Companies to offer LED options that are comparable to customers' currently installed street lights (lumens)
 - LG&E/KU should better consider customer needs when choosing new lighting options
- Collaborative participants desire flood lighting options
 - Can be installed further from the road on existing poles (therefore no excess facility charges)
- Collaborative participants desire various distribution patterns for different applications
- Temperature/Color -
 - Collaborative approved of offerings with 4000k

3) Conversion / Lack of LED Retrofit Program

- Why do Companies replace a failed mercury vapor fixture with a new high pressure sodium fixture?
 - Why? HID is old technology
- Can Companies mimic PPL's upgrade program?
- Retrofit options
 - Is a screw-in LED bulb for decorative lighting possible with Companies' existing fixtures?
 - Is the ballast removal/bypass possible?
- Mass change outs
 - How would we handle conversion and what would be impact to cities?
 - Potential problem of mass failures at same time
 - Need to cycle conversion
 - Las Vegas study
 - Replacement option for RLS lights

4) Smart/Network Lighting – Lack of Lighting Controls

- Other service options to attach to streetlights
 - Dimming, mesh network, motion/occupancy (bi-level lighting), cameras, plug and play
 - Know failures
- Could the AMS mesh network be utilized for lighting controls?

5) Lease to Own or outright purchase

- Do KU and LG&E want to remain in leased lighting business?
 - Some collaborative participants do not want to maintain streetlights
 - National Electric Code standards versus National Electric Safety Code

COLLABORATIVE MEETING #2

Reinert, Marty

From: Reinert, Marty
Sent: Monday, February 19, 2018 3:43 PM
To: [REDACTED]
Cc: Judd, Sara; Sturgeon, Allyson
Subject: LED Collaborative meeting reminder

Hope to see everyone this Friday February 23, 2018 at 1:00 pm at the Frankfort, KY Holiday Inn Express (1000 Vandalay Drive).

Just a reminder that the Collaborative is focused solely on LED street lighting.

The agenda includes a further discussion of LED fixture options and sizes as well as LED rate calculations.

Thanks!

Marty J. Reinert

Sr. Rate & Regulatory Analyst | Regulatory Strategy/Policy | LG&E and KU Energy LLC

[REDACTED]

LED Collaborative

Friday February 23, 2018

Holiday Inn Express

1000 Vandalay Drive Frankfort, KY 40601

1:00pm-5:00pm

Attending	Name	Organization	Telephone	Email
✓	Pat Johnson	Metro Louisville		
✓	Stacy Keith	Metro Louisville		
	Al Andrews	Metro Louisville		
	Max Bradley	Metro Louisville		
✓	Jim McClanahan	KSBA		
	Ben Tipton	Metro Louisville		
✓	James Bush	Lexington		
✓	Richard Dugas	Lexington		
✓	Jeff Neal	Lexington		
✓	Kenya Stump	DEDI		
✓	Rick Bender	DEDI		
✓	Kent Chandler <i>Justin McNeil</i>	Attorney General		
	John Nipple	KSBA		
✓	<i>DIRK GOWIN</i>	<i>METRO LOUISVILLE</i>		

LED COLLABORATIVE



Meeting #2
February 23, 2018
Frankfort, KY



LED Collaborative Goal

To engage in good faith to discuss issues related to LED lighting to determine what LED street lighting equipment and rate structures might be offered by KU/LG&E

Meeting #2

Costs and Options

- Review various lighting sizes available
- Review LED rate calculations

Comparable LED & HID

		KU								LG&E		
		HPS			KU		LED	LG&E		HPS		
		Bill Code	Quantity	Lumens	Bill Code	Qty	Lumens	Qty	Bill Code	Bill Code	Quantity	Lumens
Overhead	Open Bottom	428	40,213	9,500	393	17	5,007	9	493	457	3,868	9,500
	Cobra Head	463	21,987	9,500	390	1	8,179	2	490	452	8,084	16,000
	Cobra Head	464	8,600	22,000	391	3	14,166	1	491	453	12,971	28,500
	Cobra Head	465	2,993	50,000	392	10	23,214		492	454	6,373	50,000
Underground	Cobra Head	473	3,496	9,500	396		8,179		496	423	423	16,000
	Cobra Head	474	5,622	22,000	397		14,166		497	424	783	28,500
	Cobra Head	475	571	50,000	398		23,214		498	425	48	50,000
	Colonial	468	4,627	9,500	399		5,665		499	413	2,992	9,500

Top 5 HID Lights by City

Louisville Metro

Description	Bill Code	Quantity	Lumens
LS OH HPS Cobra Head Fixture	453	8,530	28,500
LS OH HPS Cobra Head Fixture	452	3,711	16,000
RLS OH MV Cobra Head Fixture	204	2,336	25,000
LS OH HPS Cobra Head Fixture	454	2,054	50,000
RLS OH MV Cobra Head Fixture	203	1,697	13,000

Lexington (LFUCG)

Description	Bill Code	Quantity	Lumens
LS OH HPS Cobra Ornamental	472	9,227	5,800
LS UG HPS Contemporary Deco	476	4,890	5,800
RLS OH HPS Cobra Hd Fix/Pole	471	3,398	4,000
LS OH HPS Cobra Ornamental	474	3,361	22,000
LS OH HPS Cobra Ornamental	473	1,937	9,500

LG&E and KU Lighting Rates

The rates for lights were determined using a standard revenue requirement approach, with (1) carrying charges, (2) distribution energy costs, and (3) operation and maintenance expenses included as revenue requirements for the monthly rates. The carrying charges include (a) depreciation expenses, (b) return on investment, (c) income taxes and (d) property taxes.

KU LED Cost Support

KENTUCKY UTILITIES COMPANY
LED LIGHTING TARIFF

	Overhead		Underground	Underground Decorative
Bill Code	Open Bottom Yard Light 50 WATT 5,007 Lumen 393 <u>Fixture, Arm & Wire</u>	Cobra 134 WATT 14,166 Lumen 391 <u>Fixture, Arm & Wire</u>	Cobra 80 WATT 8,179 Lumen 396 <u>Pole, Fixture, Arm & Wire</u>	Colonial 68 WATT 5,665 Lumen 399 <u>Fixture, Pole & Wire</u>
Monthly Rate - 7/1/2017	\$9.94	\$18.09	\$35.44	\$37.51
Estimated Investment per Unit (\$)	\$550.60	\$932.84	\$2,383.01	\$2,329.56
Fixed Charges (\$ / yr)	\$87.30	\$147.91	\$377.86	\$369.38
Distribution Energy per kWh (\$ / yr) (FAC Roll in 9/1/2017)	\$14.09	\$37.76	\$22.54	\$19.16
Operation and Maintenance (\$ / yr)	\$17.29	\$29.89	\$23.94	\$60.83
Monthly Rate After FAC Roll in - 9/1/2017	\$9.89	\$17.96	\$35.36	\$37.45
ECR Roll in 1/30/2018	0.82	0.64	1.04	0.77
Monthly Rate After ECR Roll in - 1/30/2018	\$10.71	\$18.60	\$36.40	\$38.22

LG&E LED Cost Support

LOUISVILLE GAS AND ELECTRIC COMPANY LED LIGHTING TARIFF

	Overhead		Underground	Underground Decorative
Bill Code	Open Bottom Yard Light 50 WATT 5,007 Lumen 493 <u>Fixture, Arm & Wire</u>	Cobra 134 WATT 14,166 Lumen 491 <u>Fixture, Arm & Wire</u>	Cobra 80 WATT 8,179 Lumen 496 <u>Pole, Fixture, Arm & Wire</u>	Colonial 68 WATT 5,665 Lumen 499 <u>Fixture, Pole & Wire</u>
Monthly Rate - 7/1/2017	\$9.48	\$17.43	\$52.66	\$45.46
Estimated Investment per Unit (\$)	\$493.08	\$856.57	\$3,564.69	\$2,832.50
Fixed Charges (\$ / yr)	\$80.77	\$140.32	\$583.95	\$464.01
Distribution Energy per kWh (\$ / yr)	\$13.27	\$35.57	\$21.24	\$18.05
(FAC Roll in 9/1/2017)				
Operation and Maintenance (\$ / yr)	\$19.08	\$31.68	\$25.73	\$62.62
Monthly Rate After FAC Roll in - 9/1/2017	\$9.43	\$17.30	\$52.58	\$45.39
ECR Roll in 1/30/2018	\$2.10	\$2.04	\$2.05	\$2.96
Monthly Rate After ECR Roll in - 1/30/2018	\$11.53	\$19.34	\$54.63	\$48.35

KU LED O&M

Derivation of Operation and Maintenance for LED

Bill Code	393	390, 396	391, 397	392, 398	399
Fixture	\$166.03	\$252.49	\$329.84	\$632.61	\$732.06
Photocell	\$20.00	\$20.00	\$20.00	\$20.00	\$20.00
Labor	\$38.76	\$38.76	\$38.76	\$38.76	\$38.76
Total	\$224.79	\$311.25	\$388.60	\$691.37	\$790.82
Operation and Maintenance (\$ / yr)	\$17.29	\$23.94	\$29.89	\$53.18	\$60.83
Amount included in Monthly Unit Cost	\$1.44	\$2.00	\$2.49	\$4.43	\$5.07

LG&E LED O&M

Derivation of Operation and Maintenance for LED

Bill Code	493	490, 496	491, 497	492, 498	499
Fixture	\$166.03	\$252.49	\$329.84	\$632.61	\$732.06
Photocell	\$20.00	\$20.00	\$20.00	\$20.00	\$20.00
Labor	\$62.00	\$62.00	\$62.00	\$62.00	\$62.00
Total	\$248.03	\$334.49	\$411.84	\$714.61	\$814.06
Operation and Maintenance (\$ / yr)	\$19.08	\$25.73	\$31.68	\$54.97	\$62.62
Amount included in Monthly Unit Cost	\$1.59	\$2.14	\$2.64	\$4.58	\$5.22

Questions?

LED Collaborative Meeting #3

- Review HID replacement options and conversions
- Review various features and potential benefits of a smart network

Reinert, Marty

From: Reinert, Marty
Sent: Tuesday, March 13, 2018 12:11 PM
To: [REDACTED]
[REDACTED]
Cc: Judd, Sara; Sturgeon, Allyson; Hayes, Bradley; Trimble, Robert; Warren, Curtis
Subject: LED Collaborative Meeting Summary
Attachments: 02-23-18 Meeting Summary .docx

On Friday February 23, 2018 LG&E/KU held the second LED Lighting Collaborative Meeting at the Holiday Inn Express in Frankfort, KY.

Attached please find the summary of the meeting.

A reminder that Meeting #3 will be Friday March 23 at **9:00 a.m.** at the same Frankfort Holiday Inn Express.

Thanks!

Marty J. Reinert
Sr. Rate & Regulatory Analyst | Regulatory Strategy/Policy | LG&E and KU Energy LLC

[REDACTED]

LED COLLABORATIVE MEETING #2
FRIDAY 2 / 23 / 2018
Frankfort, KY

I. Summary of meeting

- A. Re-read LED Collaborative goal
- B. Followed up with items from Meeting #1
 1. Las Vegas Study
 2. Driver replacement
 3. Northeast Electric Study
 4. HID failure rates – by type, customer or Operation Center
- C. Reviewed current LED sizes in tariffs
 1. Current KU and LGE quantity installed
 2. Top 5 Lexington and Louisville HID types
- D. LED Rate Calculations (Cost Support)
 1. Capital, carrying charge, energy, O&M
 2. Selected 4 LED's
 - a. 7/1, 9/1, & 1/30 rates
 - b. Explained O&M
- E. Discussed Conversions/mass change-outs
- F. Discussed smart/mesh networks

Major Themes from External Collaborative Participants:

- Sizes Available

- Need to offer smaller Cobra Head
 - And to verify existing LED offerings better match installed HID
- Need to offer Contemporary and Directional (flood)
- Stop installing new HID fixtures
 - Only install LED going forward
- Safer for pedestrians

- Rate Calculations & Conversions

- O & M should be zero
 - Want to know KU's annual lighting O&M spend
 - Annual true-up (is too much collected?)
- Want LED at same price of HID
 - Willing to contribute a small one-time cost
 - Leave LED at HID rate
 - Possible unbundling
- Is rate methodology appropriate
- Credit should be given for fixtures on existing facilities
- Retrofit with screw-in LED bulb (with driver)

- Smart network

- Dimming and turning off could double the life
- Could Wi-Fi, etc... be utilized as a new source of lighting pole revenue?
- Smart network is not external group's top priority

Reinert, Marty

From: Reinert, Marty
Sent: Tuesday, March 27, 2018 2:04 PM
To: [REDACTED]
Cc: Sturgeon, Allyson; Judd, Sara
Subject: LED Collaborative meeting summaries
Attachments: Frankfort 12-8-17 meeting summary .pdf; 02-23-18 Meeting Summary .pdf

Per your request attached please find the meeting summaries from the LED Collaborative meetings held in Frankfort, KY on 12/8/17 and 2/23/18.

Please contact me with any questions.

Thanks!

Marty J. Reinert

Sr. Rate & Regulatory Analyst | Regulatory Strategy/Policy | LG&E and KU Energy LLC

[REDACTED]

COLLABORATIVE MEETING #3

Reinert, Marty

From: Reinert, Marty
Sent: Tuesday, March 20, 2018 4:33 PM
To: [REDACTED]
[REDACTED]
Cc: Judd, Sara; Sturgeon, Allyson; Hayes, Bradley; Trimble, Robert; Warren, Curtis
Subject: LED Collaborative Meeting #3

Reminder: Collaborative Meeting #3 is this Friday March 23 beginning **9:00 a.m.** at the Holiday Inn Express at 1000 Vandalay Drive, Frankfort, KY.

Agenda:

- LED Offerings
Current versus proposed
- LED Pricing
Utility Challenges to LED Implementation
- LED Conversion Options

Marty J. Reinert

Sr. Rate & Regulatory Analyst | Regulatory Strategy/Policy | LG&E and KU Energy LLC

[REDACTED]

LED Collaborative

Friday March 23, 2018

Holiday Inn Express

1000 Vandalay Drive Frankfort, KY 40601

9:00 a.m. - 12:00 p.m.

Attending	Name	Organization	Telephone	Email																										
✓	Justin McNeil	Attorney General	[REDACTED]	[REDACTED]																										
✓	Kenya Stump	DEDI			[REDACTED]	[REDACTED]																								
✓	Rick Bender	DEDI					[REDACTED]	[REDACTED]																						
✓	Jim McClanahan	KSBA							[REDACTED]	[REDACTED]																				
✓	John Nipple	KSBA									[REDACTED]	[REDACTED]																		
✓	James Bush	Lexington											[REDACTED]	[REDACTED]																
✓	Richard Dugas	Lexington													[REDACTED]	[REDACTED]														
✓	Jeff Neal	Lexington															[REDACTED]	[REDACTED]												
✓	Pat Johnson	Metro Louisville																	[REDACTED]	[REDACTED]										
✓	Stacy Keith	Metro Louisville																			[REDACTED]	[REDACTED]								
✓	Al Andrews	Metro Louisville																					[REDACTED]	[REDACTED]						
✓	Max Bradley	Metro Louisville																							[REDACTED]	[REDACTED]				
✓	Ben Tipton	Metro Louisville																									[REDACTED]	[REDACTED]		
✓	Dirk Gowin	Metro Louisville																											[REDACTED]	[REDACTED]

LED Collaborative Meeting #3

March 23, 2018

Agenda

- LED Offerings
 - Current versus proposed
- LED Pricing
 - Utility Challenges to LED implementation
- LED Conversion Options

LED Offerings

- Explore adding Contemporary, Directional, Acorn, and additional Cobra LEDs
- Decorative retrofits – determine whether screw-in bulb is a viable option on the utility scale

LED options - Current HPS Cobra - 5,800 lumens (70W) Conroy

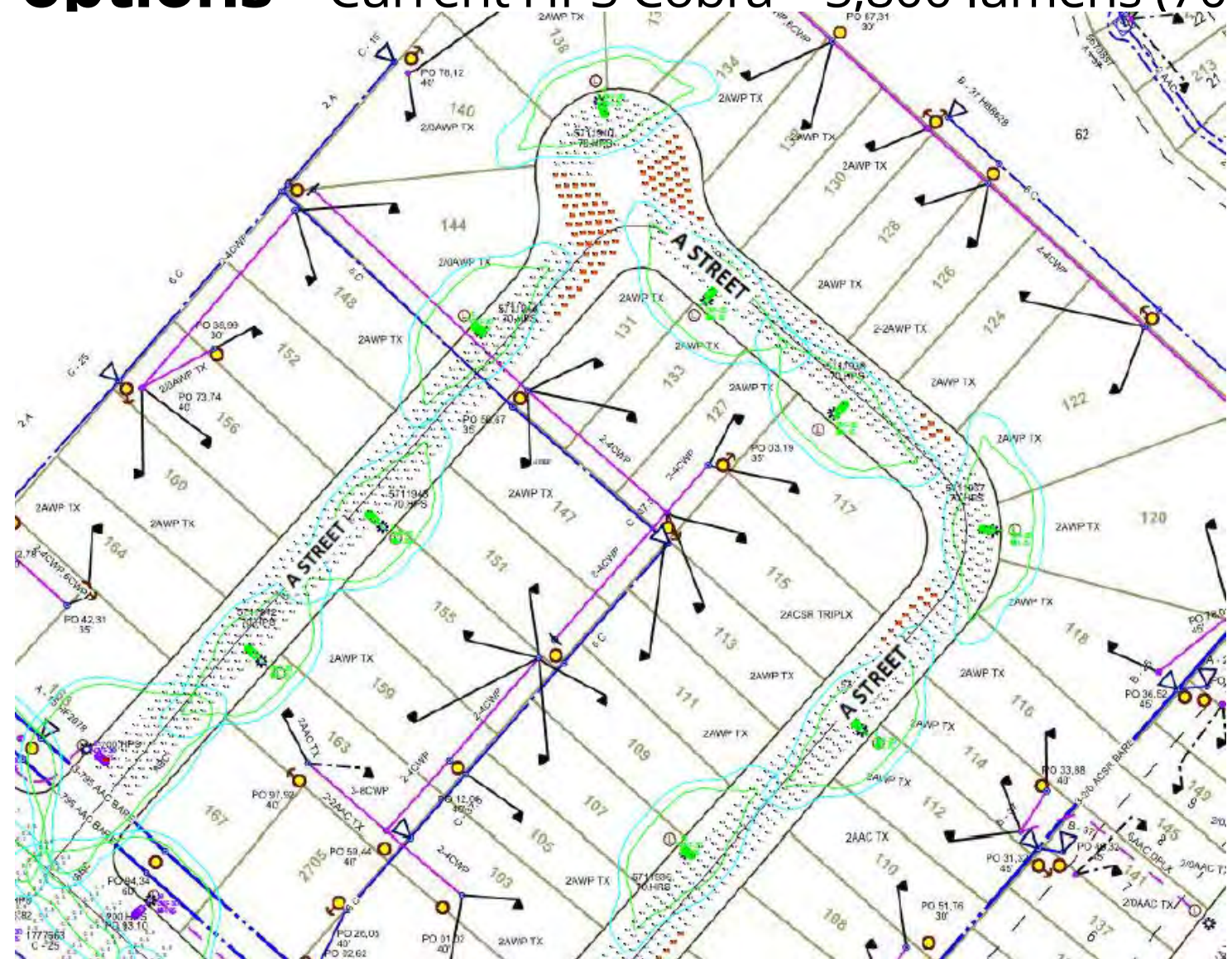

LED options - Current Cobra LED - 8,179 lumen (70W) Conroy

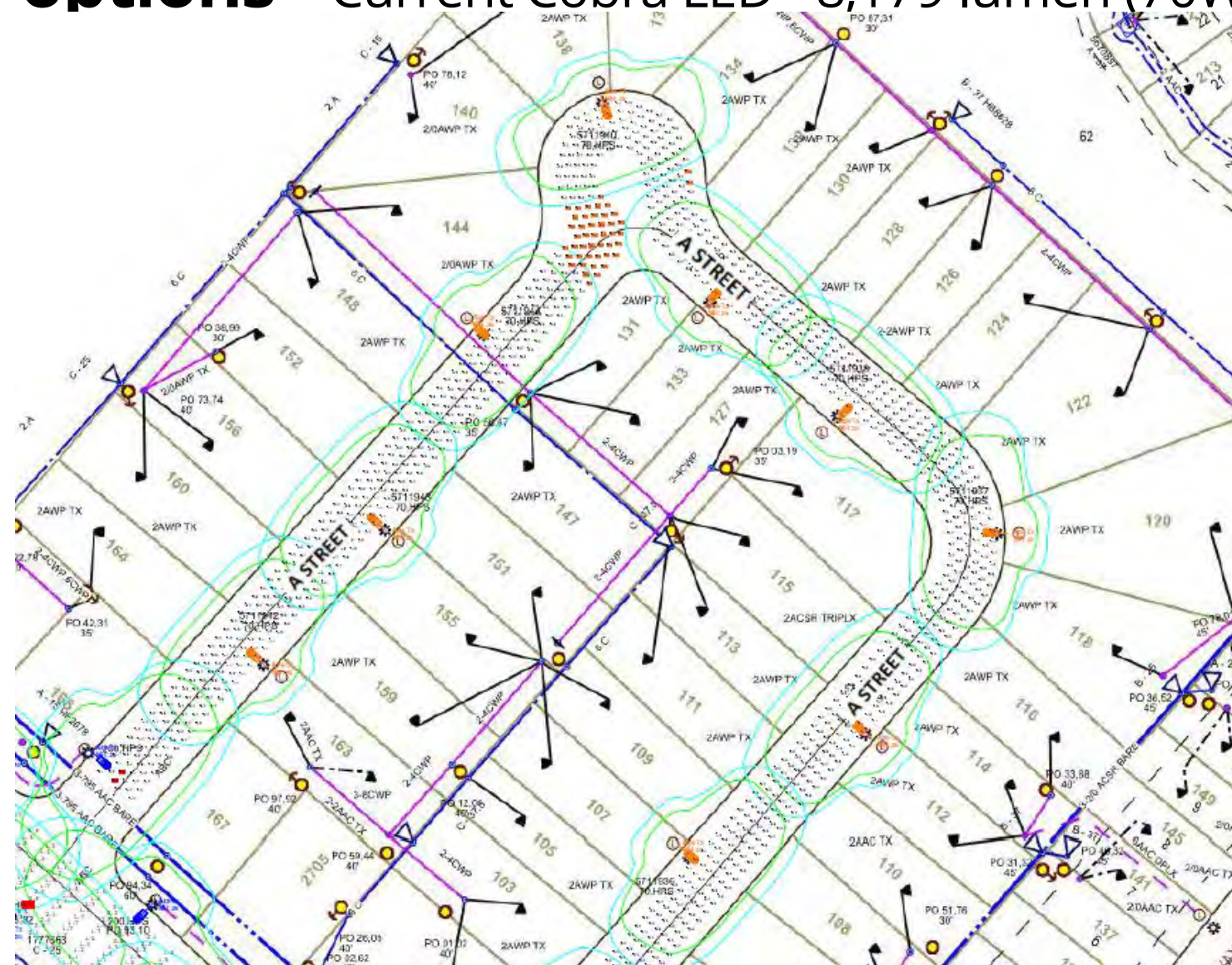

LED options - Potential Cobra LED - 3,800 lumen (30W) Conroy

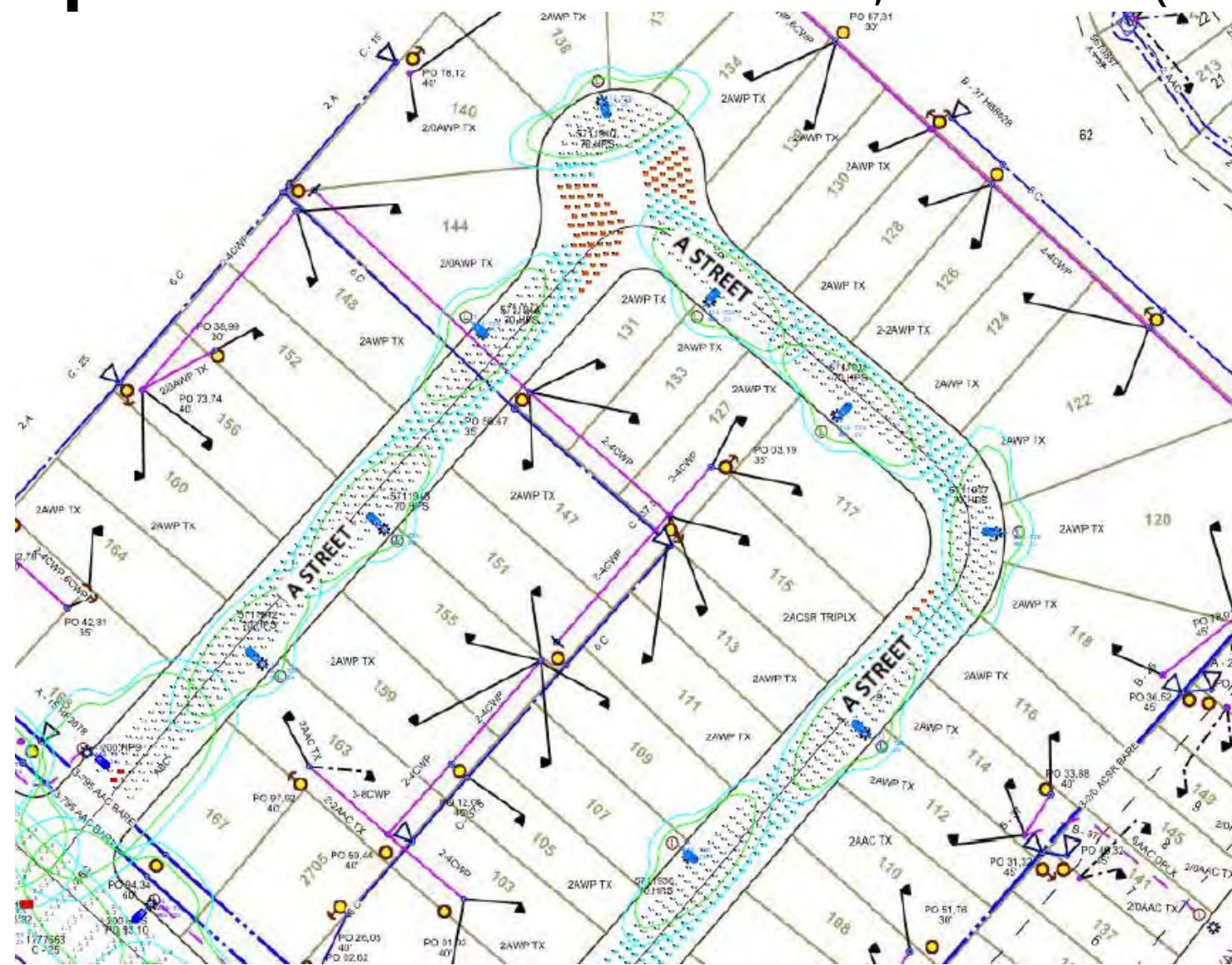

LED Offerings

Current HID Offerings			Proposed LED	
Rate Code/Desc	Lumens	kW/Light	Lumens (Approx.)	kW/Light (Approx.)
453-HPS Cobra Head	28,500	0.294	14,166	.134
452-HPS Cobra Head	16,000	0.181	8,179	.080
204-MV Cobra Head	25,000	0.462	14,166	.134
454-HPS Cobra Head	50,000	0.471	23,214	.228
203-MV Cobra Head	13,000	0.298	8,179	.080
472-HPS Cobra Head	5,800	0.083	3,800	.030
476-HPS Contemporary	5,800	0.083		
471-HPS Cobra Head	4,000	0.060	3,800	.030
474-HPS Cobra Head	22,000	0.242	14,166	.134
473-HPS Cobra Head	9,500	0.117	8179	.080

LED Pricing

- Allocating the revenue requirement for the lighting class to each light type based on the cost of each type of lighting fixture
- Costs include the carrying charges (depreciation expenses, return on investment, income taxes and property taxes), energy costs, environmental cost recovery, and operation and maintenance expenses (i.e. replacement)

LED Pricing

Utility Challenges to LED implementation

- Better Buildings – US DOE
 - “Regulatory Issues and Approaches to Municipal LED Street Lighting Conversions”
 - Rates include three major components
 - 1) **Energy charge (DOE estimates approximately 20% of lighting rates)**
 - Generation charge – cost to utility to generate energy
 - Transmission and Distribution charge – costs to deliver energy to customer (operating, maintaining, depreciation of T&D infrastructure)
 - 2) **Lighting Asset Base Charge (DOE estimates approximately 60% of lighting rates)**
 - Poles, wires, fixtures, photocells, labor
 - *Income and property taxes, depreciation of lighting fixtures and infrastructure, and return on investment
 - 3) **Maintenance costs (DOE estimates approximately 20% of lighting rates)**
 - Maintenance of lighting system
- Current LED market changes

* Utility rates also includes these items

LED Pricing

LED life-span

- “Building Technologies Program – Solid-State Lighting Technology Fact Sheet”
 - Why do LED’s fail?
 - Driver: 52% (power supply)
 - Housing: 31% (thermal management, materials, gaskets, etc)
 - LED package: 10% (Lumen maintenance falls below acceptable level)
 - Diver control circuit: 7%
 - LED lifetime and reliability standards
 - This paper cites several standards developed by the Illuminating Engineering Society to help better understand LED lifetime and reliability
 - LG&E/KU will review these standards to help identify the proper lifespan and reliability of LEDs built into our lighting rates

LED Pricing

LG&E/KU current LED rates

- Energy costs is 4 to 20% of current monthly LED rates
 - Overhead rates: energy costs is 12 to 20% of monthly rates
 - Underground rates: energy costs is 4 to 11% of monthly rates
- Lighting Asset Base is 64 to 93% of current monthly LED rates
 - Overhead rates: 64 to 74% of monthly rates
 - Underground rates: 80 to 93% of monthly rates
- Maintenance costs is 4 to 17% of current monthly LED rates
 - Overhead rates: 13 to 17% of monthly rates
 - Underground rates: 4 to 8% of monthly rates

LED Pricing

- Solicit updated pricing from vendors before next base rate case
- Research and establish LED life-span (depreciation life)
- Evaluate the required O&M for LED fixtures
- Evaluate the rate options of a new LED fixture and current pole

LED Conversion Options

- Add a sunset date to all Restricted Lighting Service offerings
- Add a sunset date to all current HID fixtures
- Move all HID fixtures to Restricted Lighting Service
 - No HID replacements
- Removal of assets that are not fully depreciated
 - The undepreciated value HID fixtures removed from the field has to be recovered
 - The partially depreciated assets supporting existing HID lights (poles, wire, labor, etc.) have to continue to be recovered when that fixture is replaced with an LED

Reinert, Marty

From: Reinert, Marty
Sent: Wednesday, May 02, 2018 10:47 AM
To: [REDACTED]
Cc: Judd, Sara; Sturgeon, Allyson; Hayes, Bradley; Trimble, Robert; Warren, Curtis
Subject: LED Collaborative Meeting #3 Summary
Attachments: 3-23-18 Meeting Summary .docx

On Friday March 23, 2018 LG&E/KU held the third and final LED Lighting Collaborative Meeting at the Holiday Inn Express in Frankfort, KY.

Attached please find the summary of the meeting.

We hope to have a master summary of the three meetings compiled soon which will be forwarded to the group upon completion.

Thanks!

Marty J. Reinert
Sr. Rate & Regulatory Analyst | Regulatory Strategy/Policy | LG&E and KU Energy LLC

[REDACTED]

LED COLLABORATIVE MEETING #3

FRIDAY 3 / 23 / 2018

Frankfort, KY

Agenda

- A. LED offerings – Current vs. Proposed
 - 1. Explore adding new styles and additional sizes
 - 2. Explore option of screw-in type LED

- B. LED pricing
 - 1. Utility challenges -
 - a. Revenue requirement and carrying cost components
 - b. kWh and O&M costs each

 - 2. For further review
 - a. Updated vendor pricing
 - b. Analyze appropriate LED life-span
 - c. Analyze appropriate O & M
 - d. Analyze appropriate costs of existing excess facilities (stranded costs)

- C. LED conversion options
 - 1. Sunset date for Restricted Lighting Service
 - 2. Sunset date for current HID fixtures
 - 3. Move all HID fixtures to Restricted Lighting Service. Only offer LED fixtures.
 - 4. How to account for undepreciated fixtures and excess facilities

Major Themes from External Collaborative Participants:

Review KY D.O.T. requirements when evaluating LED offerings

Current LED wattages are too high for current offerings

Offerings – Reduce quantity but offer “correct” type of fixtures

- Find correct offering balance
- Suggestions
 - o Partnering with 3rd party
 - o Investigating new technologies such as dimming if results lower costs

Conversions and mass replacements

- What are companies' plans/strategy?
 - Will information be provided prior to next rate case?

Comments:

- If mass replacement is planned, what are logistics?
 - o Transition time period?
- Could customers be allowed to have a contribution in aid of construction option and would this lower the overall cost of streetlights?
- Prices should decrease if mass change to LED's because of quantity that will be purchased by LGE/KU
 - o Companies should require a 10-year or longer warranty period from manufacturers if large quantities are purchased

Pricing – Depreciation study versus industry

- Separate poles from current rates and have a fixture rate and a pole rate
- Do companies wish to stay in lighting business?
 - o Many hurdles to city-owned facilities – in power space meaning only certified workers allowed, National Electric Code, pole attachment fee...
- Do companies wish to partner with 3rd party vendors?

Reinert, Marty

From: Reinert, Marty
Sent: Wednesday, May 02, 2018 10:54 AM
To: [REDACTED]
Cc: Sturgeon, Allyson; Judd, Sara
Subject: LED Collaborative meeting #3 summary
Attachments: 3-23-18 Meeting Summary .pdf

Per your request attached please find the meeting summary from the final LED Collaborative meeting held in Frankfort, KY on 3/23/18.

Please contact me with any questions.

Thanks!

Marty J. Reinert

Sr. Rate & Regulatory Analyst | Regulatory Strategy/Policy | LG&E and KU Energy LLC

[REDACTED]

LOUISVILLE GAS AND ELECTRIC COMPANY

**Response to First Request for Information of the
Louisville/Jefferson County Metro Government
Dated November 13, 2018**

Case No. 2018-00295

Question No. 6

Responding Witness: Robert M. Conroy

- Q-6. One criticism that came out of the LED Collaborative is that LG&E does not track operation and maintenance expenses at a level sufficient to assess the anticipated benefits of LED lighting; nor at a level to fact-check the estimated costs used to establish lighting rates. Suggestions included tracking expenses for new installation separate from repairs and that the type of repair be known (e.g. problem related to wiring, fixture, pole, etc.)
- a. Does LG&E plan to make any changes to LS expense tracking?
 - b. If yes, please elaborate.
- A-6. All LG&E lighting maintenance activities are tracked under two budget categories at the operations center level – 1) O&M expenses and 2) capital repair/replace expenses. All LG&E new business lighting maintenance activities are tracked under a separate capital budget category at the operations center level. See also Attachment 6 to Question No. 9.
- a. LG&E always seeks to make continuous improvements in operational processes and procedures where justified by a defined business need. At this time, LG&E has no plans to make any changes to LS expense tracking
 - b. N/A

LOUISVILLE GAS AND ELECTRIC COMPANY

**Response to First Request for Information of the
Louisville/Jefferson County Metro Government
Dated November 13, 2018**

Case No. 2018-00295

Question No. 7

Responding Witness: Robert M. Conroy

- Q-7. During the LED Collaborative, participants explained that lighting customers needed information regarding a practical rollout of upgrading existing lights to LED. Does LG&E have any systematic plans to convert restricted lighting to LED by geography or by rate code?
- A-7. The Company's proposal in this proceeding with respect to LED lighting options is discussed in the testimonies of Mr. Conroy, at pages 23-24, and Mr. Seelye, at pages 37-42. In addition, the lighting options proposed are contained in the tariffs in Tab 4 of the Filing Requirements.

LOUISVILLE GAS AND ELECTRIC COMPANY

**Response to First Request for Information of the
Louisville/Jefferson County Metro Government
Dated November 13, 2018**

Case No. 2018-00295

Question No. 8

Responding Witness: John K. Wolfe

Q-8. How does LG&E define end of service for an LED, given the expected result is lumen depreciation rather than complete failure?

a. What are LG&E's plans for service/maintenance for LED lights when they near or reach the end of service?

A-8. LG&E defines end of service for an LED as when the fixture fails or when the lumens depreciate to 70% of their initial output (L70) and that depreciation becomes noticeable to the human eye. L70 is an Illuminating Engineering Society driven standard that is used in the industry's lumen maintenance testing methods.

a. LED fixtures will be replaced upon failure or when, after customer request or visual inspection, LG&E personnel determine the LED should be replaced because the lumen output has depreciated beyond a reasonable level.

LOUISVILLE GAS AND ELECTRIC COMPANY

**Response to First Request for Information of the
Louisville/Jefferson County Metro Government
Dated November 13, 2018**

Case No. 2018-00295

Question No. 9

Responding Witness: John K. Wolfe

- Q-9. For the period of 2014 to present, please provide any LG&E internal and external business plans, presentations, marketing material, feasibility studies, lighting conversion financial analyses, customer economic studies, conversion financial models, and correspondence to senior leadership as created or prepared by or for LG&E as it relates to street lighting. Bookmark the following documents in your response:
- a. Technical specifications or metrics established by LG&E that were used to select LED lighting types, such as lumen output, lumens-per-watt, warranty, L70, kelvin, etc.
 - b. Product data sheets for the new LED lighting types and LED equipment supply options as mentioned by Mr. Seelye on page 40 of his testimony.
- A-9. See attached. Certain information requested in confidential and is being provided under seal pursuant to a petition for confidential protection.

Outdoor Lighting Initiative

Tom Appel, Jan Coleman, David Cummings, Steve Denning, Tony Durbin,
Kevin Lewellen, Rick Lovekamp, Jon Winfrey

David Cummings
Outdoor Lighting Initiative
November 2, 2016

Table Of Contents

	Page
Overview	3
Lighting background	4
Standard rates for lighting	4
Current number of lighting rate codes	4
Number of lights active/inactive by tariff sheet	5
Number of lights by lamp type	6
Light Stock Inventory	7
Financial/Statistical Data	8
PPL lighting	9 – 10
Federal regulation	11
Current initiatives	12
Light audits	12 – 13
Business process review	14 – 15
Strategies reviewed	16
Status Quo	16 – 17
No longer offer lights	18 – 19
Light rate code consolidation	20
Eliminate various light offerings and move to LED	21 – 26
Recommended strategy	27 – 30
Potential Options	31

Overview

Review lighting processes and strategy to ensure proper billing, rate design, and improve operations.

- Two pronged approach to Initiative
 1. Review lighting business process and underlying policies
 - Update process to ensure lights are properly accounted for and mapped.
 - Ensure processes conform to tariffs.
 - Align processes between companies where possible.
 - Identify business policies that are different and make recommendations to align.
 - Communicate final business process documents and business policies across company.
 2. Develop/review various lighting strategies in conjunction with industry trends and make recommendations for a companywide lighting strategy going forward with consideration to:
 - Streamline offerings, pricing, and operations.
 - Maintaining tariff and business process harmonization across all companies.

Lighting Background

Standard Rates for Lighting.

- Lighting Service (LS) LG&E/KU.
- Restricted Lighting Service (RLS) (Restricted to lights in service as of January 1, 2013) LG&E/KU.
- Private Outdoor Lighting (P.O.LT.) ODP (Jurisdictional)/(KU in Tennessee).
- Street Lighting Service (ST. LT.) ODP (Non-Jurisdictional).
- Current Number of Lighting Rate Codes - LG&E, KU, and ODP:

Standard Rate/Company	LS	RLS	P.O.LT.	ST.LT.	Total
LG&E	37	43			80
KU	39	28			67
KU – Tenn.			19		19
ODP – Juris.			7		7
ODP – Non-Juris.				10	10
Total	76	71	26	10	183

Lighting Background (Continued)

Number of Lights Active/Inactive by Tariff Sheet (at October 31, 2015)

	Active				In-Active				Total				
	<u>KU</u>	<u>ODP</u>	<u>LG&E</u>	<u>Total</u>	<u>KU</u>	<u>ODP</u>	<u>LG&E</u>	<u>Total</u>	<u>KU</u>	<u>ODP</u>	<u>LG&E</u>	<u>Total</u>	
LS	145,766		47,736	193,502	9,786		1,572	11,358	155,552		49,308	204,860	63.2%
RLS	26,038		40,673	66,711	2,924		1,167	4,091	28,962		41,840	70,802	21.8%
Other ODL/ST.LT	100	2,945		3,045		6		6	100	2,951		3,051	0.9%
POLT		6,458		6,458		1,084		1,084		7,542		7,542	2.3%
Unmetered temp suspension*	48	2	230	280	67	8	37,475	37,550	115	10	37,705	37,830	11.7%
Grand Total	171,952	9,405	88,639	269,996	12,777	1,098	40,214	54,089	184,729	10,503	128,853	324,085	100.0%

*Unmetered temp suspension - This is the rate billing uses to show that the lights have either been removed or have been moved to a different installation because a different party wanted to take over the billing.

Lighting Background (Continued)

Number of Lights by Lamp Type.

Lamp Type	Rate	Active				In-Active				Total			
		KU	ODP	LG&E	Total	KU	ODP	LG&E	Total	KU	ODP	LG&E	Total
High Pressure Sodium	LS	137,206	-	46,384	183,590	8,940	-	1,558	10,498	146,146	-	47,942	194,088
	RLS	12,069	-	26,593	38,662	70	-	375	445	12,139	-	26,968	39,107
	Other ODL/ST.LT	62	2,876	-	2,938	-	5	-	5	62	2,881	-	2,943
	POLT	-	4,569	-	4,569	-	320	-	320	-	4,889	-	4,889
	Unmetered Temp. Susp.	37	1	63	101	40	4	13,862	13,906	77	5	13,925	14,007
Total High Pressure Sodium		149,374	7,446	73,040	229,860	9,050	329	15,795	25,174	158,424	7,775	88,835	255,034
Incandescent	LS	-	-	-	-	-	-	-	-	-	-	-	-
	RLS	548	-	56	604	87	-	-	87	635	-	56	691
	Other ODL/ST.LT	-	-	-	-	-	-	-	-	-	-	-	-
	POLT	-	-	-	-	-	-	-	-	-	-	-	-
	Unmetered Temp. Susp.	-	-	-	-	-	-	50	50	-	-	50	50
Total Incandescent		548	-	56	604	87	-	50	137	635	-	106	741
Metal Halide	LS	8,560	-	1,352	9,912	846	-	14	860	9,406	-	1,366	10,772
	RLS	1,732	-	118	1,850	220	-	-	220	1,952	-	118	2,070
	Other ODL/ST.LT	-	-	-	-	-	-	-	-	-	-	-	-
	POLT	-	-	-	-	-	-	-	-	-	-	-	-
	Unmetered Temp. Susp.	5	-	-	5	2	-	-	2	7	-	-	7
Total Metal Halide		10,297	-	1,470	11,767	1,068	-	14	1,082	11,365	-	1,484	12,849
Mercury Vapor	LS	-	-	-	-	-	-	-	-	-	-	-	-
	RLS	11,689	-	13,906	25,595	2,547	-	792	3,339	14,236	-	14,698	28,934
	Other ODL/ST.LT	38	69	-	107	-	1	-	1	38	70	-	108
	POLT	-	1,889	-	1,889	-	764	-	764	-	2,653	-	2,653
	Unmetered Temp. Susp.	3	1	7	11	3	4	23,473	23,480	6	5	23,480	23,491
Total Mercury Vapor		11,730	1,959	13,913	27,602	2,550	769	24,265	27,584	14,280	2,728	38,178	55,186
Unmetered Temp. Susp.	Unmetered Temp. Susp.	3	-	160	163	22	-	90	112	25	-	250	275
Grand Total		171,952	9,405	88,639	269,996	12,777	1,098	40,214	54,089	184,729	10,503	128,853	324,085

Lighting Background (Continued)

Light Stock Inventory – July 31, 2016.

Item	LG&E/KU Onsite Inventory		Brownstown Inventory**		Total	
	Quantity	Value	Quantity	Value	Quantity	Value
Accessory*	7,764	\$ 65,154	-	\$ -	7,764	\$ 65,154
Fixture:						
Incandescent	8	\$ 137		\$ -	8	\$ 137
High Pressure Sodium	1,767	\$ 270,282	2,749	\$ 281,695	4,516	\$ 551,977
Metal Halide	265	\$ 55,830	258	\$ 56,291	523	\$ 112,121
Metal Halide 1000W	42	\$ 15,399	49	\$ 24,468	91	\$ 39,867
Mercury Vapor	8	\$ 580	-	\$ -	8	\$ 580
Pole	609	\$ 334,443	-	\$ -	609	\$ 334,443
Total	10,463	\$ 741,824	3,056	\$ 362,454	13,519	\$ 1,104,278

*Accessory - Cable, photoelectric controls, arms, brackets, etc.

** Inventory amounts LG&E/KU would be liable for if contract ended as of July 31, 2016

- Brownstown Inventory – At contract end, company must purchase remaining inventory held exclusively for LG&E/KU.
 - With advance notice of a cutover to LED this amount can be managed down.
 - Brownstown maintains a 6 week supply of inventory.

Lighting Background (Continued)

Financial/Statistical Data (LG&E/KU/ODP).

- \$56.1 million revenue - 12 months ended June 2016.
- Maintenance \$1.5 million - 2016 budget.
- Capital \$12.8 million - 2016 budget (\$6.1 million new business, \$6.7 maintenance).
- Depreciation expense \$8.2 million per year based on June 2016 balance.
- Net Book Value lighting (poles, fixtures, conductor, etc.) \$139.3 million at June 30, 2016.
- Estimated property tax expense \$2 million per year.
- Energy usage 231.5 GWh - 12 months ended June 2016.

Lighting Background (Continued)

PPL Lighting.

PPL has approximately 102,000 lights, current PPL lighting tariffs:

Rate	Different Lumens	HPS (Various Configurations)	LED (Various Configurations)	Mercury Vapor (Various Configurations)	Total (Various Configurations)
SA- Private Outdoor Lighting	2	1	1		2
SM - Mercury Vapor Street Lighting*	6			25	25
SHS - High Pressure Sodium Street Light	5	23			23
SLE- Light Emitting Diode (LED)**	7		23		23
Total	20	24	24	25	73

*The mercury vapor (MV) lamps which fail will be transitioned to the High Pressure Sodium (HPS) (Rate Schedule SHS) nominal lumens equivalent or Light Emitting Diode (LED) (Rate Schedule SLE) nominal lumens equivalent. This is in accordance with the Energy Policy Act of 2005 - Section 135 H.R. 6-39, which states that "Mercury Vapor Lamp ballasts shall not be manufactured or imported after January 1, 2008."

** PPL offers 6 different fixture types (Acorn, Area Light, Cobra head, Shoe Box, Traditional, and Contemporary) all priced the same per lumen rating. HPS and Mercury Vapor are similar.

Lighting Background (Continued)

PPL Lighting (Continued).

- Introduced LED in 2015 rate case (Source: PPL Website, Brian Wynn Project Manager, PPL EU).
 - There was not a wholesale change-out to LED.
 - Customers may request to convert to LED.
 - PPL developed a tool customers could use to estimate their cost savings (costs include a one-time charge to replace fixtures less than ten years old (year 1 \$203 – year 10 \$168)).
 - 8,000 request to change to LED since new tariff took effect, January 2016.
 - Estimate replacing about 10,000 per year.
 - Not actively marketing LED.
 - LED contracts ,fifteen years for street lights, five for area lights.
 - HPS contracts , ten years for street lights, one year for area lights.

Lighting Background (Continued)

Federal Regulation.

- Mercury Vapor
 - The Energy Policy Act of 2005 – Section 135 H.R. 6-39 states that “Mercury Vapor Lamp ballasts shall not be manufactured or imported after January 1, 2008.”

	<u>Active</u>	<u>In-active</u>	<u>Total</u>	<u>Rate Codes</u>
Mercury Vapor	27,602	27,584	55,186	23 RLS/POLT

- Metal Halide
 - 2014 DOE Regulations, effective February 10, 2017, 1,000 W fixtures will need to be replaced when ballasts fail.
 - All Metal Halide orders are being placed on hold until the first of the year pending outcome of new regulations.

	<u>Active</u>	<u>In-active</u>	<u>Total</u>	<u>Rate Codes</u>
Metal Halide 1,000W	2,058	293	2,351	9 LS/RLS
Metal Halide (Excluding 1,000W)	9,709	789	10,498	21 LS/RLS/POLT
	11,767	1,082	12,849	30

Current Initiatives

Light Audits.

- Performed to ensure correct billing of lights.
- A light audit was performed on the City of Louisville (Original City Limits) in 2008-2010.
 - The audit included all City of Louisville lights and all private outdoor lights.
 - The audit was performed by Syntergetic. LG&E Assets Information employees audited Syntergetic's findings, made changes to GIS, and followed up with billing.
 - A grid system for accounting for lights was developed during the audit process to enhance performance of future audits for the city of Louisville.

Current Initiatives

Light Audits (continued).

- Current audits of the KU and LG&E territory are being conducted by Asset Information personnel.
 - There are approximately 200 cities in the KU territory and 147 cities in LGE electric service territory. Since 2010, 47 cities and 49 cities in the KU and LG&E territories, respectively, have been audited.
 - Audits are ongoing. All cities are being reviewed and will be audited as resources are available. Additional audits are performed at the request of external and/or internal customers.
 - Private outdoor lights within a franchise area are included in the audits, those private outdoor lights outside the city limits are not currently being audited.

Current Initiatives (continued)

Business Process Review.

- Review/update business process to promote consistency between companies and compliance with tariffs and improve operations.
 - Inconsistency between companies will exist due to different group structure between LG&E, KU, and ODP (dedicated group for LG&E), but it is not significant.
 - Process improvement - Asset Information to scan all contracts (currently scan only LG&E).
 - Business policy concerns.
 - Contracts
 - Universal contract needed for all companies.
 - When do we obtain a contract.
 - LG&E gets a contract on every new install.
 - KU/ODP contract only when additional facilities are needed.

Current Initiatives (continued)

Business Process Review (continued).

- Review/update business process to promote consistency between companies and compliance with tariffs and improve operations (continued).
 - Business policy concerns (continued).
 - Contracts (continued).
 - Enforce contract terms consistently.
 - Bill maintenance for other than burnout – in tariffs but not being billed.

Strategies Reviewed

Status Quo.

- Maintain current light rate structure.
- Continue fixture replacement when ballast fails on Mercury Vapor, Incandescent, and 1,000 watt Metal Halide with a LS HPS or LED equivalent fixture (meets current Federal regulations).

	<u>Active</u>	<u>In-active</u>	<u>Total</u>	<u>Rate Codes</u>			
				<u>LS</u>	<u>RLS</u>	<u>POLI</u>	<u>Total</u>
Mercury Vapor	27,602	27,584	55,186	-	20	3	23
Incandescent	604	137	741	-	7	-	7
Metal Halide 1,000W	2,058	293	2,351	6	3	-	9
	<u>30,264</u>	<u>28,014</u>	<u>58,278</u>	<u>6</u>	<u>30</u>	<u>3</u>	<u>39</u>

- Eliminates 39 rate codes through attrition.
- Continue to review/update lighting business process and policies to promote operational improvements, consistency between companies, and compliance with tariffs.

Strategies Reviewed

Status Quo (continued).

- Continue audits as scheduled and as requested.
- Continue monitoring lighting manufacturer trends to determine how it may affect light offerings.

Strategies Reviewed

No longer offer lights.

- Sell lights, offer maintenance service, move all customers to rate LE.

	Sell lights - One Time Event, Move all customers to rate LE:		
	Current	Sell - No Maintenance	Sell - Offer Maintenance
	Amount	Amount	Amount
Estimated Revenue			
Current Revenue - 12 Months Ending June 30, 2016	\$ 56,177,171	\$ -	\$ -
LE Tariff Revenue - Estimated	\$ -	\$ 16,562,311	\$ 16,562,311
Maintenance Contract Revenue - Estimated	\$ -	\$ -	\$ 8,220,000
Total Estimated Revenue	\$ 56,177,171	\$ 16,562,311	\$ 24,782,311
Estimated Costs			
Estimated Energy Costs	\$ (6,465,266)	\$ (6,465,266)	\$ (6,465,266)
Estimated Property Tax	\$ (2,019,497)	\$ -	\$ -
Annual Depreciation Expense	\$ (8,242,904)	\$ -	\$ -
Maintenance Expense (2016 Budget)	\$ (1,518,000)	\$ -	\$ (1,518,000)
Maintenance Expense currently capitalized (2016 Budget)	\$ -	\$ -	\$ (6,702,000)
Total Estimated Costs	\$ (18,245,667)	\$ (6,465,266)	\$ (14,685,266)
Estimated Contribution	\$ 37,931,504	\$ 10,097,045	\$ 10,097,045
Change from Current		\$ (27,834,460)	\$ (27,834,460)
Sell lights - One Time Event, Move all customers to rate LE:			
One Time Gain - Net Book Value	\$ -	\$ 139,268,241	\$ 139,268,241
Inventory write off	\$ -	\$ (1,104,278)	\$ -
	\$ -	\$ 138,163,963	\$ 139,268,241
Capital savings - New Business/Maint. (2016 Budget)	\$ -	\$ 12,800,000	\$ 12,800,000

Strategies Reviewed (continued)

No longer offer lights (continued).

- Sell lights, offer maintenance service, move all customers to rate LE (continued).
 - \$27.8 million annual reduction in contribution.
 - Poor customer experience.
 - Large expense for customer.
 - Maintenance falls to customer (diminished reliability) or customer contracts with Company.
 - Pole attachment issues (not allow customer owned light on company poles).
 - KPSC issues.
 - Meter costs.
 - Personnel issues.

Strategies Reviewed (continued)

Light rate code consolidation.

- Goes against sound cost of service principals.
- Winners and losers, very political customer base.
 - Summary of December 2015 rate code consolidation analysis:
 - 11,816 Business Partners with 108,550 lights get a decrease.
 - 48,894 Business Partners with 153,815 lights get an increase.
 - (25,261 lights in City of Louisville).
 - See light rate code consolidation presentation “Lighting Rate Code Consolidation” dated December 1, 2015.

Strategies Reviewed (continued)

Eliminate various light offerings and move to LED.

- Scenario 1 – Wholesale change out of Mercury Vapor, Incandescent, and 1,000 watt Metal Halide fixtures that are currently replaced with LS offering when ballast fails.

	<u>Active</u>	<u>In-active</u>	<u>Total</u>	<u>Rate Codes</u>			
				<u>LS</u>	<u>RLS</u>	<u>POLI</u>	<u>Total</u>
Mercury Vapor	27,602	27,584	55,186	-	20	3	23
Incandescent	604	137	741	-	7	-	7
Metal Halide 1,000W	2,058	293	2,351	6	3	-	9
	30,264	28,014	58,278	6	30	3	39

- Scenario 2 - Wholesale change out of fixtures mandated by Federal Regulation.

	<u>Active</u>	<u>In-active</u>	<u>Total</u>	<u>Rate Codes</u>			
				<u>LS</u>	<u>RLS</u>	<u>POLI</u>	<u>Total</u>
Mercury Vapor	27,602	27,584	55,186	-	20	3	23
Metal Halide 1,000W	2,058	293	2,351	6	3	-	9
	29,660	27,877	57,537	6	23	3	32

Strategies Reviewed (continued)

Eliminate various light offerings and move to LED (continued).

- Scenario 3 – Wholesale change out of fixtures on rate RLS and mandated by Federal Regulation.

	<u>Active</u>	<u>Inactive</u>	<u>Total</u>	<u>Rate Codes</u>			
				<u>LS</u>	<u>RLS</u>	<u>POLT</u>	<u>Total</u>
High Pressure Sodium	38,662	445	39,107	-	28	-	28
Incandescent	604	137	741	-	7	-	7
Metal Halide (excl. 1,000W)	9,709	789	10,498	12	7	2	21
Metal Halide 1,000W	2,058	293	2,351	6	3	-	9
Mercury Vapor	27,602	27,584	55,186	-	20	3	23
	78,635	29,248	107,883	18	65	5	88

- Scenario 4 – Wholesale change out of all fixtures.

	<u>Active</u>	<u>In-active</u>	<u>Total</u>	<u>Rate Codes</u>			
				<u>LS</u>	<u>RLS</u>	<u>POLT</u>	<u>Total</u>
High Pressure Sodium	229,759	11,268	241,027	57	28	32	117
Incandescent	604	137	741	-	7	-	7
Metal Halide	11,762	1,080	12,842	18	10	2	30
Mercury Vapor	27,602	27,584	55,186	-	20	3	23
	269,727	40,069	309,796	75	65	37	177

Strategies Reviewed (continued)

Eliminate various light offerings and move to LED (continued).

- Cost/savings assumptions.
 - High level costs/savings estimates
 - LG&E/KU proposed LED fixture and labor costs matched to existing fixtures based on approximate lumen and watt.
 - Stranded asset costs (Net Book Value for all fixtures) \$99.3 million – seek recovery from KPSC.
 - Energy savings with LED – ranges reported* 39% - 63% non-peak energy savings.
 - Variable production costs pricing, 12 month rolling average \$27.93/MWh.
 - Inventory - actual cost held by LG&E/KU and Brownstown.
 - Maintenance savings range reported* - 30% - 50% per light per year.

*Northeast Energy Efficiency Partnerships, “LED Street Lighting Assessment and Strategies for the Northeast and Mid-Atlantic”, dated January 2015, and New York State Energy Research and Development Authority, “Street Lighting in New York State: Opportunities and Challenges”, dated January 2015.

Strategies Reviewed (continued)

Eliminate various light offerings and move to LED (continued).

- Cost/savings assumptions (continued).

	Scenario 1 <u>MV / Incand / 1000W MH</u>	Scenario 2 <u>Fed. Reg. Lights</u>	Scenario 3 <u>RLS/Fed. Reg. Lights</u>	Scenario 4 <u>All Lights</u>
Number of Active Lights	30,264	29,660	78,635	269,727
Percentage of total	11%	11%	29%	100%
Estimated Costs (\$ in millions):	<u>Range</u>	<u>Range</u>	<u>Range</u>	<u>Range</u>
Costs	\$31.1 - \$42.9	\$30.8 - \$42.4	\$72.9 - \$83.5	\$265.8 - \$287.7
Stranded Asset Costs - (Net Book Value)	\$17.3 - \$17.3	\$17.3 - \$17.3	\$30.5 - \$30.5	\$99.3 - \$99.3
Inventory Costs write-off	\$0.0 - \$0.0	\$0.0 - \$0.0	\$0.2 - \$0.2	\$1.1 - \$1.1
Total	\$48.4 - \$60.3	\$48.2 - \$59.7	\$103.5 - \$114.1	\$366.2 - \$388.1
Annual Energy Savings - GWh (non-peak)	16.6 - 26.8	16.4 - 26.4	30.7 - 49.7	90.3 - 145.8
Annual Costs/Savings (\$ in millions):				
Additional Depreciation Expense	\$0.5 - \$1.0	\$0.5 - \$1.0	\$1.6 - \$2.0	\$6.4 - \$7.2
Additional Property Tax Expense	\$0.2 - \$0.4	\$0.2 - \$0.4	\$0.6 - \$0.8	\$2.4 - \$2.7
Variable Production Costs Savings	(\$0.5) - (\$0.7)	(\$0.5) - (\$0.7)	(\$0.9) - (\$1.4)	(\$2.5) - (\$4.1)
Maintenance Savings (Expense and Capital)	(\$0.3) - (\$0.5)	(\$0.3) - (\$0.5)	(\$0.7) - (\$1.2)	(\$2.5) - (\$4.1)
Total	(\$0.0) - \$0.1	(\$0.0) - \$0.1	\$0.7 - \$0.2	\$3.8 - \$1.8

Strategies Reviewed (continued)

Eliminate various light offerings and move to LED (continued).

- Benefits.
 - Energy Savings
 - Maintenance Costs Savings
 - Extended Lifecycle
 - Lower carbon emissions
 - “Dark Sky” light pollution improvements due to improved optical control.
 - Sharper contrast brighter light improves visibility and provides greater perceived security.
 - Partial/Complete system audit - Every active light within each scenario would be removed and replaced, giving an accurate count and location.
 - In-active and unmetered lights in each scenario would be removed.

Strategies Reviewed (continued)

Eliminate various light offerings and move to LED (continued).

- Issues.
 - High cost to replace fully functioning lights.
 - Stranded Asset Costs \$17.3 million - \$99.3 million (Net Book Value for fixtures only).
 - Seek recovery from KPSC, recovery would increase cost to customers.
 - AMA Health Warning
- Other.
 - All scenarios meet current federal regulations.
 - Very political customer base.

Recommended Strategy

Recommend strategy Status Quo with the following additions.

- In next rate case.
 - True-up cost of service study.
 - Add LED offerings to tariffs.
 - Move Metal Halide fixtures to tariff sheet RLS.
 - Update tariffs to reflect current company practices.
 - Remove spot replacement language from RLS Availability of Service for lights being replaced when ballast fails.

AVAILABILITY OF SERVICE

Service under this rate schedule is restricted to those lighting fixtures/poles in service as of January 1, 2013, except where a spot replacement maintains the continuity of multiple fixtures/poles composing a neighborhood lighting system or continuity is desired for a subdivision being developed in phases. Spot placement of restricted fixtures/poles is contingent on the restricted fixtures/poles being available from manufacturers. Spot replacement of restricted units will be made under the terms and conditions provided for under non-restricted Lighting Service Rate LS. Spot replacements will not be available for Mercury Vapor rate codes and Incandescent rate codes.

In the event restricted fixtures/poles fail and replacements are unavailable, Customer will be given the choice of having Company remove the failed fixture/pole or replacing the failed fixture/pole with other available fixture/pole.

Recommended Strategy

Recommend strategy Status Quo with the following additions (continued).

- In next rate case (continued).
 - Update tariffs to reflect current company practices (continued).
 - Remove spot replacement language from RLS Availability of Service for lights being replaced when ballast fails (continued).

	<u>Active</u>	<u>In-active</u>	<u>Total</u>	<u>Rate Codes</u>			
				<u>LS</u>	<u>RLS</u>	<u>POLI</u>	<u>Total</u>
Mercury Vapor	27,602	27,584	55,186	-	20	3	23
Incandescent	604	137	741	-	7	-	7
Metal Halide (excl. 1,000W)	9,709	789	10,498	12	7	2	21
Metal Halide 1,000W	2,058	293	2,351	6	3	-	9
	<u>39,973</u>	<u>28,803</u>	<u>68,776</u>	<u>18</u>	<u>37</u>	<u>5</u>	<u>60</u>

Recommended Strategy

Recommend strategy Status Quo with the following additions (continued).

- In next rate case (continued).
 - Update tariffs to reflect current company practices (continued).
 - Either mandate or remove, billing for maintenance other than burnout, from Terms and Conditions of LS/RLS tariffs. It is not currently being enforced consistently.

TERMS AND CONDITIONS

~~3. Customer shall be responsible for the cost of fixture replacement or repairs where such replacement or repairs are caused from willful damage, vandalism, or causes other than normal burnouts.~~ Company may decline to provide or continue service in locations where, in Company's judgment, such facilities will be subject to unusual hazards or risk of damage.

- Develop Business Policies to be applied consistently at all companies and across all customers for the following.
 - Contracts.
 - Universal contract.
 - When to get a contract.
 - Process to enforce terms.

Recommended Strategy

Recommend strategy Status Quo with the following additions (continued).

- Review in-active and unmetered temp suspension lights.
- Consider audit plan for all lights outside currently audited cities and all in-active/unmetered lights.
- Consider creating organizational structure dedicated to both KU/LG&E lighting.

Recommended Strategy (continued)

Potential Options.

- Perform full economic analysis to evaluate filing for system wide LED change out, that is also capable of evaluating all scenarios discussed.
- Develop tool to estimate cost to switch to LED (Similar to PPL).



PPL companies

Lighting Rate Code Consolidation

December 1, 2015



Lighting Rate Codes

- During the 2012 LG&E/KU rate case, members of State Regulations and Rates and Distribution Operations worked together to reduce the number of rate codes from 286 down to the current level of 147 rate codes, a reduction of 49%.
- LG&E and KU both have two Standard Rates for Lighting
 - LS- Lighting Service
 - RLS – Restricted Lighting Service (Restricted to lights in service as of January 1, 2013)

- Current Number of Lighting Rate Codes - LG&E and KU

Standard Rate	<u>LS</u>	<u>RLS</u>	<u>TOTAL</u>
LG&E	37	43	80
KU	39	28	67
Total	76	71	147

Lighting Rate Codes (Continued)

- Sample Tariff Sheet LS offerings:

OVERHEAD SERVICE

Based on Customer's lighting choice, Company will furnish, own, install, and maintain the lighting unit. A basic overhead service includes lamp, fixture, photoelectric control, mast arm, and, if needed, up to 150 feet of conductor per fixture on existing wood poles (fixture only). Company will, upon request furnish ornamental poles, of Company's choosing, together with overhead wiring and all other equipment mentioned for basic overhead service.

RATE

Rate Code	Type of Fixture	Approximate Lumens	kW Per Light	Monthly Charge Fixture Only
High Pressure Sodium				
452	Cobra Head	16,000	0.181	\$12.83
453	Cobra Head	28,500	0.294	15.09
454	Cobra Head	50,000*	0.471	17.39
455	Directional	16,000	0.181	\$13.78
456	Directional	50,000*	0.471	18.22
457	Open Bottom	9,500	0.117	\$10.87
Metal Halide				
470	Directional	12,000	0.150	\$12.80
473	Directional	32,000	0.350	18.69
476	Directional	107,800*	1.080	39.62

Methods Used to Consolidate Lighting Rate Codes

Maintain the current Standard Rate LS/RLS structure with the following exceptions (LG&E and KU Only):	Method			
	<u>1</u>	<u>2</u>	<u>3</u>	<u>4</u>
Eliminate overhead/underground distinction		✓	✓	✓
Eliminate type of fixture distinction (Cobra Head, Directional, etc.)	✓	✓	✓	✓
Consolidate pole types (Historic Fluted, Decorative Smooth, etc.)	✓	✓	✓	✓
Consolidate lighting into four groups based on approximate lumens or pole/restricted class: Group 1 < 12,000 lumens, Group 2 between 12,000 and 100,000 lumens, Group 3 > 100,000 lumens, Group 4 pole only or restricted class	✓	✓		
Eliminate approximate lumens or pole/restricted class			✓	✓
Group Metal Halide to achieve less than a \$6.50 increase per light				✓
Estimated pricing for consolidated groups using weighted average costing	✓	✓	✓	✓

Methods Used to Consolidate Lighting Rate Codes (Continued)

Illustration - High Pressure Sodium and Metal Halide:

	Tariff	Rate Code	Service Type	Type of Light	Type of Fixture	Approx. Lumens	kW Per Light	Monthly Charge	
								Fixture Only	Ornamental
Current Tariff	LS	462	Overhead	High Pressure Sodium	Cobra Head	5,800	0.083	\$ 9.38	
	LS	472	Overhead	High Pressure Sodium	Cobra Head	5,800	0.083		\$ 12.56
	LS	487	Overhead	High Pressure Sodium	Directional	9,500	0.117	\$ 9.75	

	Tariff	Rate Code	Service Type	Type of Light	Type of Fixture	Lumens Group	kW Per Light	(Consolidate pole types)	Monthly Charge
									Charge
Method 1	LS	111	Overhead	High Pressure Sodium	n/a	< 12,000	n/a	With Pole	\$ 12.56
	LS	222	Overhead	High Pressure Sodium	n/a	< 12,000	n/a	Without Pole	\$ 9.57
Method 2	LS	333	n/a	High Pressure Sodium	n/a	< 12,000	n/a	With Pole	\$ 12.56
	LS	444	n/a	High Pressure Sodium	n/a	< 12,000	n/a	Without Pole	\$ 9.57
Method 3	LS	555	n/a	High Pressure Sodium	n/a	n/a	n/a	n/a	\$ 10.56
Method 4	LS	666	n/a	High Pressure Sodium	n/a	n/a	n/a	n/a	\$ 10.56
	LS	777	n/a	Metal Halide - 1	n/a	n/a	n/a	n/a	\$ 6.50
	LS	888	n/a	Metal Halide - 2	n/a	n/a	n/a	n/a	\$ 6.00

Methods Used to Consolidate Lighting Rate Codes (Continued)

- Number of rate codes currently and with each alternative method

	Number of Rate Codes	Max. Monthly Charge Increase Per Rate Code
Current	147	n/a
Method 1	66	\$6.31
Method 2	51	\$6.31
Method 3	15	\$16.47
Method 4	22	\$6.38

- Business Partner counts and number of lights used in this analysis based on July 2015.
- Revenue and revenue impacts were calculated using the current price per rate code multiplied by corresponding July quantities. These represent a single month of lighting revenue.

Range of Customer Impact Across Percent Change

Method 1

Percent Change		Decrease			Increase		
From	To	Business Partner	Avg \$	Largest \$	Business Partner	Avg \$	Largest \$
		Count at July 2015	Impact/Month	Impact/Month	Count at July 2015	Impact/Month	Impact/Month
0%	5%	7,011	\$ (3)	\$ (9,143)	7,173	\$ 1	\$ 883
5%	10%	8,135	\$ (3)	\$ (3,034)	27,500	\$ 2	\$ 20,753
10%	15%	4,020	\$ (11)	\$ (753)	727	\$ 22	\$ 4,294
15%	20%	140	\$ (33)	\$ (299)	1,114	\$ 11	\$ 264
20%	25%	120	\$ (41)	\$ (527)	2,847	\$ 7	\$ 1,524
25%	30%	310	\$ (23)	\$ (669)	1,172	\$ 5	\$ 223
30%	35%	85	\$ (163)	\$ (7,387)	18	\$ 43	\$ 124
35%	40%	15	\$ (57)	\$ (296)	239	\$ 25	\$ 204
40%	45%	13	\$ (327)	\$ (3,658)	28	\$ 48	\$ 1,072
45%	50%	12	\$ (186)	\$ (740)	0	\$ -	\$ -
50%	55%	24	\$ (63)	\$ (512)	0	\$ -	\$ -
55%	60%	4	\$ (210)	\$ (468)	0	\$ -	\$ -
100%	105%	3	\$ -	\$ -	0	\$ -	\$ -

NOTE: Largest \$ impacts are driven by the number of lights

Range of Customer Impact Across Percent Change (Continued)

Method 2

Percent Change		Decrease			Increase		
From	To	Business Partner	Avg \$	Largest \$	Business Partner	Avg \$	Largest \$
		Count at July 2015	Impact/Month	Impact/Month	Count at July 2015	Impact/Month	Impact/Month
0%	5%	6,944	\$ (1)	\$ (511)	6,915	\$ 3	\$ 9,518
5%	10%	8,145	\$ (3)	\$ (3,022)	27,638	\$ 2	\$ 20,857
10%	15%	4,050	\$ (10)	\$ (744)	735	\$ 23	\$ 4,395
15%	20%	166	\$ (39)	\$ (325)	1,134	\$ 12	\$ 264
20%	25%	162	\$ (39)	\$ (462)	3,082	\$ 7	\$ 575
25%	30%	300	\$ (27)	\$ (923)	1,182	\$ 4	\$ 223
30%	35%	77	\$ (239)	\$ (7,387)	0	\$ -	\$ -
35%	40%	120	\$ (71)	\$ (602)	2	\$ 7	\$ 12
40%	45%	15	\$ (307)	\$ (3,658)	0	\$ -	\$ -
45%	50%	12	\$ (186)	\$ (740)	0	\$ -	\$ -
50%	55%	22	\$ (35)	\$ (125)	0	\$ -	\$ -
60%	65%	6	\$ (307)	\$ (590)	0	\$ -	\$ -
100%	105%	3	\$ -	\$ -	0	\$ -	\$ -

NOTE: Largest \$ impacts are driven by the number of lights

Range of Customer Impact Across Percent Change (Continued)

Method 3

Percent Change		Decrease			Increase		
From	To	Business Partner	Avg \$	Largest \$	Business Partner	Avg \$	Largest \$
		Count at July 2015	Impact/Month	Impact/Month	Count at July 2015	Impact/Month	Impact/Month
0%	5%	1,268	\$ (7)	\$ (1,587)	700	\$ 19	\$ 8,450
5%	10%	2,157	\$ (8)	\$ (2,662)	5,013	\$ 4	\$ 1,829
10%	15%	2,419	\$ (8)	\$ (509)	800	\$ 33	\$ 4,293
15%	20%	980	\$ (95)	\$ (69,567)	1,528	\$ 28	\$ 2,779
20%	25%	688	\$ (40)	\$ (794)	1,292	\$ 19	\$ 1,451
25%	30%	414	\$ (50)	\$ (1,810)	812	\$ 18	\$ 714
30%	35%	315	\$ (59)	\$ (788)	9,381	\$ 4	\$ 297
35%	40%	1,658	\$ (31)	\$ (1,451)	953	\$ 13	\$ 2,089
40%	45%	300	\$ (102)	\$ (3,473)	470	\$ 14	\$ 163
45%	50%	385	\$ (60)	\$ (1,272)	26,441	\$ 5	\$ 497
50%	55%	58	\$ (398)	\$ (11,986)	131	\$ 30	\$ 183
55%	60%	92	\$ (112)	\$ (517)	2,204	\$ 7	\$ 192
60%	65%	35	\$ (327)	\$ (1,932)	29	\$ 29	\$ 113
65%	70%	1	\$ (324)	\$ (324)	13	\$ 44	\$ 100
70%	75%	5	\$ (348)	\$ (659)	145	\$ 17	\$ 160
80%	85%	0	\$ -	\$ -	4	\$ 28	\$ 34
85%	90%	0	\$ -	\$ -	1	\$ 19	\$ 19
100%	105%	4	\$ -	\$ -	0	\$ -	\$ -

NOTE: Largest \$ impacts are driven by the number of lights

Range of Customer Impact Across Percent Change (Continued)

Method 4

Percent Change		Decrease			Increase		
From	To	Business Partner	Avg \$	Largest \$	Business Partner	Avg \$	Largest \$
		Count at July 2015	Impact/Month	Impact/Month	Count at July 2015	Impact/Month	Impact/Month
0%	5%	2,520	\$ (5)	\$ (1,166)	1,033	\$ 14	\$ 8,450
5%	10%	2,227	\$ (9)	\$ (2,668)	5,075	\$ 5	\$ 1,856
10%	15%	2,444	\$ (8)	\$ (509)	795	\$ 29	\$ 4,293
15%	20%	962	\$ (94)	\$ (68,933)	1,340	\$ 30	\$ 2,779
20%	25%	694	\$ (38)	\$ (692)	415	\$ 30	\$ 1,446
25%	30%	356	\$ (45)	\$ (1,831)	738	\$ 18	\$ 702
30%	35%	293	\$ (53)	\$ (804)	9,357	\$ 4	\$ 297
35%	40%	1,599	\$ (27)	\$ (1,274)	1,083	\$ 12	\$ 2,089
40%	45%	167	\$ (135)	\$ (3,473)	453	\$ 13	\$ 163
45%	50%	370	\$ (53)	\$ (1,272)	26,434	\$ 5	\$ 497
50%	55%	55	\$ (408)	\$ (11,986)	5	\$ 19	\$ 22
55%	60%	84	\$ (118)	\$ (1,868)	2,166	\$ 7	\$ 192
60%	65%	35	\$ (282)	\$ (1,889)	0	\$ -	\$ -
65%	70%	1	\$ (324)	\$ (324)	0	\$ -	\$ -
70%	75%	5	\$ (348)	\$ (659)	0	\$ -	\$ -
100%	105%	4	\$ -	\$ -	0	\$ -	\$ -

NOTE: Largest \$ impacts are driven by the number of lights



Customer Impacts

Top 10 \$ Increase/Decrease

Method 1

Top 10 Customers with negative impact - \$						Top 10 Customers with positive impact - \$					
Rank	BP Name	No. of Lights	July 2015 Revenue	Increase	% Increase	Rank	BP Name	No. of Lights	July 2015 Revenue	Decrease	% Decrease
1	[REDACTED]	25,261	\$ 402,658	\$ 20,753	5%	1	[REDACTED]	30,813	\$ 451,969	\$ (9,143)	-2%
2	[REDACTED]	3,122	\$ 41,044	\$ 4,294	10%	2	[REDACTED]	675	\$ 23,632	\$ (7,387)	-31%
3	[REDACTED]	2,742	\$ 32,930	\$ 1,716	5%	3	[REDACTED]	251	\$ 8,390	\$ (3,658)	-44%
4	[REDACTED]	629	\$ 7,232	\$ 1,524	21%	4	[REDACTED]	1,739	\$ 31,806	\$ (3,034)	-10%
5	[REDACTED]	883	\$ 9,927	\$ 1,170	12%	5	[REDACTED]	733	\$ 9,850	\$ (828)	-8%
6	[REDACTED]	676	\$ 8,563	\$ 1,160	14%	6	[REDACTED]	399	\$ 5,269	\$ (753)	-14%
7	[REDACTED]	224	\$ 2,498	\$ 1,072	43%	7	[REDACTED]	44	\$ 1,501	\$ (740)	-49%
8	[REDACTED]	426	\$ 8,696	\$ 903	10%	8	[REDACTED]	118	\$ 2,584	\$ (669)	-26%
9	[REDACTED]	2,021	\$ 27,127	\$ 883	3%	9	[REDACTED]	1,768	\$ 17,674	\$ (611)	-3%
10	[REDACTED]	702	\$ 12,245	\$ 702	6%	10	[REDACTED]	1,318	\$ 15,923	\$ (600)	-4%

Method 2

Top 10 Customers with negative impact - \$						Top 10 Customers with positive impact - \$					
Rank	BP Name	No. of Lights	July 2015 Revenue	Increase	% Increase	Rank	BP Name	No. of Lights	July 2015 Revenue	Decrease	% Decrease
1	[REDACTED]	25,261	\$ 402,658	\$ 20,857	5%	1	[REDACTED]	675	\$ 23,632	\$ (7,387)	-31%
2	[REDACTED]	30,813	\$ 451,969	\$ 9,518	2%	2	[REDACTED]	251	\$ 8,390	\$ (3,658)	-44%
3	[REDACTED]	3,122	\$ 41,044	\$ 4,395	11%	3	[REDACTED]	1,739	\$ 31,806	\$ (3,022)	-10%
4	[REDACTED]	676	\$ 8,563	\$ 1,162	14%	4	[REDACTED]	86	\$ 2,983	\$ (1,022)	-34%
5	[REDACTED]	2,131	\$ 22,964	\$ 1,032	4%	5	[REDACTED]	96	\$ 3,194	\$ (923)	-29%
6	[REDACTED]	629	\$ 7,232	\$ 996	14%	6	[REDACTED]	118	\$ 2,584	\$ (863)	-33%
7	[REDACTED]	426	\$ 8,696	\$ 871	10%	7	[REDACTED]	101	\$ 2,556	\$ (828)	-32%
8	[REDACTED]	883	\$ 9,927	\$ 846	9%	8	[REDACTED]	399	\$ 5,269	\$ (744)	-14%
9	[REDACTED]	702	\$ 12,245	\$ 704	6%	9	[REDACTED]	44	\$ 1,501	\$ (740)	-49%
10	[REDACTED]	224	\$ 2,498	\$ 575	23%	10	[REDACTED]	65	\$ 2,174	\$ (723)	-33%

Customer Impacts

Top 10 \$ Increase/Decrease (Continued)

Method 3

Top 10 Customers with negative impact - \$						Top 10 Customers with positive impact - \$					
Rank	BP Name	No. of Lights	July 2015			Rank	BP Name	No. of Lights	July 2015		
			Revenue	Increase	% Increase				Revenue	Decrease	% Decrease
1	[REDACTED]	25,261	\$ 402,658	\$ 8,450	2%	1	[REDACTED]	30,813	\$ 451,969	\$ (69,567)	-15%
2	[REDACTED]	2,250	\$ 39,407	\$ 4,293	11%	2	[REDACTED]	675	\$ 23,632	\$ (11,986)	-51%
3	[REDACTED]	1,768	\$ 17,674	\$ 2,779	16%	3	[REDACTED]	251	\$ 8,390	\$ (3,473)	-41%
4	[REDACTED]	425	\$ 5,378	\$ 2,089	39%	4	[REDACTED]	2,742	\$ 32,930	\$ (2,662)	-8%
5	[REDACTED]	2,033	\$ 24,002	\$ 1,829	8%	5	[REDACTED]	96	\$ 3,194	\$ (1,932)	-60%
6	[REDACTED]	1,211	\$ 14,381	\$ 1,777	12%	6	[REDACTED]	86	\$ 2,983	\$ (1,889)	-63%
7	[REDACTED]	1,350	\$ 15,614	\$ 1,574	10%	7	[REDACTED]	236	\$ 6,134	\$ (1,810)	-30%
8	[REDACTED]	646	\$ 6,774	\$ 1,451	21%	8	[REDACTED]	1,739	\$ 31,806	\$ (1,587)	-5%
9	[REDACTED]	1,110	\$ 19,951	\$ 1,434	7%	9	[REDACTED]	2,021	\$ 27,127	\$ (1,486)	-5%
10	[REDACTED]	2,131	\$ 22,964	\$ 1,339	6%	10	[REDACTED]	110	\$ 3,845	\$ (1,451)	-38%

Method 4

Top 10 Customers with negative impact - \$						Top 10 Customers with positive impact - \$					
Rank	BP Name	No. of Lights	July 2015			Rank	BP Name	No. of Lights	July 2015		
			Revenue	Increase	% Increase				Revenue	Decrease	% Decrease
1	[REDACTED]	25,261	\$ 402,658	\$ 8,450	2%	1	[REDACTED]	30,813	\$ 451,969	\$ (68,933)	-15%
2	[REDACTED]	2,250	\$ 39,407	\$ 4,293	11%	2	[REDACTED]	675	\$ 23,632	\$ (11,986)	-51%
3	[REDACTED]	1,768	\$ 17,674	\$ 2,779	16%	3	[REDACTED]	251	\$ 8,390	\$ (3,473)	-41%
4	[REDACTED]	425	\$ 5,378	\$ 2,089	39%	4	[REDACTED]	2,742	\$ 32,930	\$ (2,668)	-8%
5	[REDACTED]	2,033	\$ 24,002	\$ 1,856	8%	5	[REDACTED]	86	\$ 2,983	\$ (1,889)	-63%
6	[REDACTED]	1,350	\$ 15,614	\$ 1,552	10%	6	[REDACTED]	96	\$ 3,194	\$ (1,868)	-58%
7	[REDACTED]	1,211	\$ 14,381	\$ 1,484	10%	7	[REDACTED]	236	\$ 6,134	\$ (1,831)	-30%
8	[REDACTED]	646	\$ 6,774	\$ 1,446	21%	8	[REDACTED]	1,739	\$ 31,806	\$ (1,721)	-5%
9	[REDACTED]	1,110	\$ 19,951	\$ 1,434	7%	9	[REDACTED]	2,021	\$ 27,127	\$ (1,482)	-5%
10	[REDACTED]	2,131	\$ 22,964	\$ 1,339	6%	10	[REDACTED]	65	\$ 2,174	\$ (1,348)	-62%

Issues/Concerns

- Operational impacts
 - Existing rate structure in Louisville is very solid both from auditing process and from internal /external inquires of our street lighting assets. We know exactly what type of lights a customer has because each fixture type has its own rate code.
 - For a customer will multiple types of lights, it could create challenges for auditing customers records.
 - If existing rate structure is consolidated, the current light information will have to be maintained in SmallWorld.

Issues/Concerns (Continued)

- Operational impacts (continued)
 - Simplify the RSG and BI process associated with adding and removing lights.
 - Logistics of migrating the existing structure to the new structure in CCS has not been determined.
 - Might be risky to change rate categories in midst of code freeze during CCS upgrade.
- Cross subsidization of monthly charge (current prices range from \$3.67 - \$72.59)

Issues/Concerns (Continued)

- kW ratings will be calculated for each new group using a weighted average, causing Fuel Adjustment Clause (FAC) cross subsidization.
- Biggest \$ impacts to government and cities because of number of lights.
- Costs will not be recovered if customers move from a lower price (currently) to higher price (currently) fixture that is in the same proposed pricing group.
- New cost structure may cause revenue loss.

Issues/Concerns (Continued)

- Method 4 achieves the lowest number of rate codes with the lowest monthly maximum charge increase.
- Company has 147 rate codes, of which 71 are restricted to those in service at January 1, 2013 leaving 76 rate codes for new lighting customers to choose from.

Recommendations

- Leave rate structure as is. Operations believes current process is effective and provides the customer and company the appropriate level of detail to support billing and maintenance of lighting.
- Next steps

**LED Lighting Business Case
Strategic Issues and Opportunities**

Executive Summary

LKE has the opportunity to invest in LED outdoor lighting at a time when LED technology is in high demand and is becoming the predominant lighting option for electric utilities. The Companies have identified a strategic opportunity for proactive conversion of approximately 75,000 lights across the service territory. This replacement strategy will target customers currently with traditional lights where the company expects to offer a lower cost LED equivalent during the next rate case. The estimated cost of this project is \$42 million and will take approximately 3 years to complete. Under this proposal, LKE expects to meet customer expectations and demands while anticipating that it will earn its allowed return on equity and recovering the undepreciated value of the fixtures that it removes from service.

Background

I. Description of Issue or Opportunity

LED lighting is quickly replacing traditional alternatives due to increased energy efficiency and superior lighting quality. The long-term expectation is that manufacturers or regulators will phase out all other lighting technologies in favor of LEDs. IOUs, municipalities and RECCs across the country are making efforts to convert outdoor lighting to LEDs. There are three primary drivers behind these efforts: 1) energy savings, 2) customer demand, and 3) reduced operation and maintenance costs.

LKE has 271,000 lights in the field. KU has 172,000, LG&E has 89,000 and ODP has 10,000. These lights generate approximately \$51 million in annual revenue for the companies.¹ LKE first introduced LED light offerings in the 2016 rate case by offering four street lighting options and one area light.² Currently, all but one of these LED offerings have rates that are more expensive than the traditional lighting offerings. As of February 1, 2018, LKE has installed ten LED lights.

LKE's customer perspective is relatively simple – LKE's LED rates are too expensive, particularly when compared to traditional lighting offerings. Customers expect LEDs to be cheaper due to energy savings and O&M savings. Traditional lighting fixtures require on-going maintenance, whereas it is anticipated that LED fixtures remain in the field for 15 years without any maintenance.³ The most important factor in a light for most LKE customers is price. It would be challenging for the Companies to implement a system-wide conversion to LED given the current tariff rates because that would require customers to pay higher rates for LEDs than customers are paying for traditional lights today.

The opportunity before LKE is to implement a plan to convert LKE's lighting assets to LED, either partial or system-wide. By seizing this opportunity, LKE can invest capital to provide customers with a cost effective offering for a product they desire and condense the cumbersome billing process for lighting caused by the abundance of lighting rate codes.

II. Timeline for threat or opportunity

The opportunity begins now with planning to update rates and planning a conversion strategy in preparation for the next electric base rate case, which is anticipated to be filed in 2018 with new rates going into effect in May 2019. The conversion to LED lighting will take a number of years, beginning upon the approval of new rates from

¹ See Appendix A for additional LKE lighting data points and rate comparisons.

² Rate cases 2016-0370 and 2016-0371.

³ LKE estimates up to 1% of LED lights will fail each year, prior to end of their estimated useful life.

the PSC. LKE’s capital investment in an LED conversion will at least carry through 2022, while a system-wide conversion could take a few years beyond that.

III. Triggers/Events that could accelerate threat or opportunity

This opportunity has two primary forces that will accelerate the timeline: the filing of a rate case in 2018 and LKE’s capital spending strategy. A future triggering event is the anticipated phasing out of traditional lighting technologies by regulators, manufacturers, and/or market forces - reinforcing this opportunity and recommendation to be proactive in converting existing lights to LED’s.

IV. Interdependencies

Under the existing rate structure and due to the ongoing availability of traditional lighting fixtures, LKE anticipates, that at this time, it cannot require customers to convert to a more expensive LED fixture. Currently, LKE’s only ability to address any rate change associated to LED’s or traditional lighting offerings is through a rate case.

Alternatives Considered

I. Alternative N - Items LKE should do regardless of alternatives considered

LKE will update the LED rates to reflect new fixture prices, a 15-year depreciable life, and add seven additional LED rates for traditional lighting options that do not have a comparable LED offering in the existing tariff book. Additionally, LKE will explore options for rate design to “future proof” rates against rapidly changing LED fixture costs. The cost of most LED fixtures is declining and those costs today are lower than many of the LED fixture costs used in the 2016 rate cases. LED technology is improving and becoming ubiquitous resulting in better efficiencies and lower prices. The life of and efficiency of LED fixtures is continuing to improve. LKE expects the LED fixtures purchased today to last 15 years, and expects those fixtures to be more efficient than those LED fixtures in today’s tariffs. Updating the rates to reflect the new fixture prices and a 15-year depreciable life will help bring the LED rates closer to traditional rates. This will primarily benefit the overhead rates; such that LKE expects six of the eight projected overhead LED rates to be lower than the comparable traditional lighting rate. However, even with updated fixture prices and longer lifespans, LKE’s underground LED rates continue to be significantly higher than the traditional lighting rates due to the fixed pole costs. As exemplified in the 2016 rate cases, intervenors refusal to settle when presented with requested rate increases to LKE’s traditional lighting fixtures, combined with present day fixed pole costs built into the LED rates; LKE will not be able to implement a system-wide conversion to LED lights without a change in tactics. The chart below illustrates the projected LED rates based on lower fixture costs and the 15-year depreciable life.

	Overhead				Underground			
	Open Bottom	Cobra A	Cobra B	Cobra C	Colonial	Cobra A	Cobra B	Cobra C
Kentucky Utilities								
Current Traditional Rate	\$8.76	\$10.24	\$15.85	\$25.17	\$12.82	\$14.11	\$20.00	\$27.95
Projected LED Rate	\$9.20	\$12.44	\$15.10	\$18.69	\$32.31	\$32.96	\$35.62	\$39.21
Louisville Gas & Electric								
Current Traditional Rate	\$11.81	\$13.60	\$15.88	\$18.14	\$21.97	\$28.32	\$30.54	\$36.33
Projected LED Rate	\$8.32	\$11.31	\$14.07	\$18.08	\$40.59	\$49.61	\$52.37	\$56.38

II. Alternative I - Partial LED Conversion

Conversion of 75,000 overhead lights to LED at a capital cost of \$42 million.

LKE anticipates that by updating the LED rates in the manner described above, there will be a cheaper comparable LED alternative for approximately 75,000 LKE lights. These are overhead lights, with approximately 39,000 in KU, 34,000 in LG&E, and 2,000 in ODP. Instead of lowering the rate for these lights below the comparable traditional lighting rate, LKE would set the LED rate equal to the equivalent traditional lighting rate. LKE would use the difference between the tariff LED rate and calculated LED rate to recover the undepreciated value of the fixtures to be removed from service. LKE expects to fully recover the undepreciated net book value of the 75,000 fixtures to be removed from service in 22 years for LG&E and 12 years for KU. LKE would move all traditional lighting rate codes with a cheaper LED option to the Restricted Lighting Service tariff schedule (RLS) and seek PSC approval for proactive replacement of these fixtures. LKE estimates it can proactively replace these lights in three years following implementation of new rates at a capital cost of approximately \$42 million.⁴

LKE also anticipates an additional 72,000 traditional lights with a comparable LED with a rate within \$2.50 cents of the traditional light rate. LKE will continue to explore ways to address undepreciated net book value for any additional lights converted to LED. LKE should implement better practices for LEDs to display its lighting offerings. LKE currently does not have any information related to outdoor lighting on the LGE-KU webpage. LKE should develop a landing page on its webpage for lights that describe all of the current offerings and provide proper contacts to secure outdoor lighting based on the customer’s location. LKE should provide uniform informational materials, which explain the different lights available, to operations and customer service representatives who handle lighting requests and should make an effort to explain the new LED offerings to customers and the benefits of LEDs. LKE’s key account managers should explain the LED offerings available to key customers, particularly those offerings that have a comparable rate to the traditional lighting offerings.

In addition, LKE can take steps to make the remaining LED options more attractive to customers. LKE can implement an “upgrade rate” for underground LED fixtures.⁵ Essentially, this upgrade rate will give customers with existing underground fed lights credit for the pole in the ground. Customer could convert these existing lights to an LED at a discounted rate based on the idea that they should not have to pay for a brand new pole, the cost of which goes into the underground LED rates. The upgrade rate allows LKE to show its customers that it is making a good faith effort to make LEDs more accessible to customers in a manner that is fair to the customer and to LKE. Ultimately, underground LED rates may remain cost prohibitive to customers even with the upgrade rate.

	Underground			
	Colonial	Cobra A	Cobra B	Cobra C
Kentucky Utilities				
Current Traditional Rate	\$12.82	\$14.11	\$20.00	\$27.95
Projected LED Rate	\$32.31	\$32.96	\$35.62	\$39.21
Projected LED Upgrade Rate	\$20.56	\$23.14	\$25.80	\$29.39
Louisville Gas & Electric				
Current Traditional Rate	\$21.97	\$28.32	\$30.54	\$36.33
Projected LED Rate	\$40.59	\$49.61	\$52.37	\$56.38
Projected LED Upgrade Rate	\$26.57	\$31.13	\$33.89	\$37.89

⁴ See Appendix C for conversion costs explanation and assumptions.

⁵ See Appendix B for explanation of the “upgrade rate” is calculation. Upgrade rate and methodology is still under evaluation.

Lastly, this proposed strategy aligns with PPL's current practice today. In January 2016, PPL began offering LED lights. PPL's LED options for area lighting (yards and parking lots) have a cheaper rate than traditional area lighting offerings, in contrast, the LED street lighting options remain more expensive. During the first 18 months of the LED offerings, PPL converted approximately 20,000 area lights to LED and saw little adoption of LED street lighting. PPL is now taking a proactive approach to converting all outdoor area lighting to LED but does not yet have any plans to convert street lighting to LED due to higher costs to customers. PPL is investing roughly \$60 million to convert all area lighting to LED.

III. Alternative II – System-wide LED conversion

Convert all of LKE's 271,000 lights to LED at a capital cost of approximately \$125 million over five years.

Until there is some intervening event that precludes LKE from offering traditional lights, we have discovered no feasible way for LKE to get approval (from KPSC and/or customers) to implement a system-wide LED conversion without adjusting the LED rates such that they are comparable to the traditional lighting rates. This alternative calls for LKE to adjust the rate for LEDs such that they are equal to the comparable traditional lighting rate ⁶ As part of the 2016 rate case, LKE filed lighting rates based on today's material and labor cost, but ultimately agreed to a settlement below those rates. Looking only at the fixture costs, energy costs, and O&M costs, LEDs cost LKE less to own, operate and maintain than a traditional lighting fixture over the depreciation term of the traditional fixture.⁷ This suggests LKE could improve its position by offering LEDs at the current price of traditional fixtures. However, this alternative neglects the undepreciated value of lighting assets to be removed from the field. Unless LKE can find a way to recover these costs, this alternative is not feasible.

Recommendation – Alternative I – Partial LED Conversion

I. Project Description

- Convert all LEDs where LED rate is cheaper than the traditional lighting rate
- Institute an upgrade rate for customers to convert traditional underground lighting to LED
- Market LEDs
 - Employees/contractors working with municipalities, commercial customers, neighborhood associations, etc. will push LED offerings and explain conversion to LED of certain fixtures
 - Bill insert to residential customers, webpage for LED offerings, and proper marketing materials for ops centers and marketing employees/contractors
- Continue to develop a plan to convert all lighting assets to LED

II. Project Resources

- Field resources: eight two-man crews and three one-man crews
- Project manager to oversee conversion
- Additional back office staff to assist in administration and updating customer billing (TBD)

III. Project Costs

- \$42 million

IV. Project Timeline

- Completion of high level planning and preparation by July 2018 for rate case.
- Field conversion will begin May 2019 and take approximately three years to complete.

⁶ All RLS rates grouped with comparable Lighting Service (LS) HPS rate. All LED rates made equal to the comparable LS HPS rate. LKE does not plan to offer a comparable LED for a small number of traditional lighting offerings.

⁷ See Appendix D for further explanation of costs to own, operate, and maintain LED vs traditional fixtures.

Financial Analysis

I. Alternative I - Partial LED Conversion

	<u>Year 1</u>	<u>Year 7</u>	<u>Year 15</u>	<u>Year 22</u>
Revenue	\$12,140	\$12,140	\$12,140	\$12,140
Recovery of NBV	1,633	1,633	676	301
Total Revenue	<u>\$13,774</u>	<u>\$13,774</u>	<u>\$12,816</u>	<u>\$12,441</u>
Energy	(2,181)	(2,181)	(2,181)	(2,181)
Interest	(978)	(978)	(978)	(978)
Property Tax	(861)	(861)	(861)	(864)
Depreciation	(3,579)	(3,579)	(3,579)	(3,579)
Depreciation of NBV	(1,633)	(1,633)	(676)	(301)
Income Tax	(1,766)	(1,766)	(1,766)	(1,766)
Total Expenses	<u>(10,999)</u>	<u>(10,999)</u>	<u>(10,042)</u>	<u>(9,669)</u>
Net Income	\$2,774	\$2,774	\$2,774	\$2,774
Equity	28,602	28,602	28,602	28,602
ROE	<u>9.70%</u>	<u>9.70%</u>	<u>9.70%</u>	<u>9.70%</u>
Balance of \$27.6M				
Undepreciated NBV	<u>\$25,977</u>	<u>\$16,176</u>	<u>\$5,035</u>	<u>\$301</u>

Risk Analysis

I. Regulatory

Any change in lighting rates or conversion plans require PSC approval. Additional risk of Alternative II is perpetuating the problem that lighting rates may not match current costs.

II. Legal

LKE has contracts in effect with customers whose lights are less than 5 years old. These contracts may require revision if the lights under contract are targeted for conversion.

III. Customers

Customers (primarily municipalities) are unhappy with the current LED offerings and prices. Customers expect that LEDs should be cheaper and they are beginning to look for alternative lighting solutions. The longer LKE's LED offerings are too expensive to be practicable for customers, the higher the risk becomes that we will lose those lighting customers, thus losing the return we earn on capital investment related to lighting.

Customer will likely remain unhappy with a partial conversion. Municipal customers not only desire LEDs for anticipated energy and costs savings; LEDs also deliver better quality light and shows the city is keeping up with technology. Cities want these lights in their most visible downtown areas that typically use underground fed lights. A partial conversion will not address these highly visible underground lights.

IV. Organization and Operations

Any proactive LED conversion program will burden Electric Distribution Operations (EDO), Billing Integrity, and Customer Service. EDO will need to hire incremental contractor resources to convert lights to LEDs. EDO will need personnel to direct and oversee these incremental resources. The Billing Integrity group will need to update all the lighting rate codes and customer bills to ensure they are billed the appropriate rate going forward. Customer Services groups will need to assist in notifying and coordinating replacement of customer fixtures. This major project will likely be competing for resources with the proposed AMS deployment. The potential impact to Billing Integrity and the various Customer Services groups require further evaluation. Those potential costs are not considered in this proposal.

Appendix A – LKE Lighting Facts

- KU has 172,000 lights (129,000 overhead fed (OH), and 43,000 underground fed (UG).
- LG&E has 89,000 lights (52,000 OH, 37,000 UG)
- ODP has 9,400 lights (9,000 OH, 400 UG)
- LKE annual revenue \$51,072,000
 - ◆ KU annual revenue \$29,675,000
 - ◆ LG&E annual revenue \$20,074,000
 - ◆ ODP annual revenue \$1,323,000
- 2017 Capital and O&M Spend on Lights
 - ◆ Capital: \$12M (\$6M new business, \$6M repair/replace)
 - ◆ O&M: \$1.1M
- 2017 Net Book Value of all lighting assets: \$151M
 - ◆ 2017 Depreciation expense: \$9M
- 2017 Net Book Value of fixtures only: \$95M
 - ◆ 2017 KU/ODP Fixture Net Book Value: \$55M
 - ◆ 2017 LG&E Fixture Net Book Value: \$40M
- Estimated property tax: \$2 million per year
- 2017 energy usage: 234 GWh

Table 1: Current Lighting Rate Comparisons

	Overhead				Underground			
	Open Bottom	Cobra A	Cobra B	Cobra C	Colonial	Cobra A	Cobra B	Cobra C
Kentucky Utilities								
Current Traditional Rate	\$8.76	\$10.24	\$15.85	\$25.17	\$12.82	\$14.11	\$20.00	\$27.95
Current LED Rate	\$9.89	\$14.84	\$17.94	\$27.41	\$37.45	\$35.36	\$38.48	\$47.92
2016 Filed Traditional Rate	\$9.74	\$12.03	\$15.65	\$22.04	\$24.00	\$31.32	\$34.93	\$41.33
Louisville Gas & Electric								
Current Traditional Rate	\$11.81	\$13.60	\$15.88	\$18.14	\$21.97	\$28.32	\$30.54	\$36.33
Current LED Rate	\$9.43	\$14.28	\$17.30	\$26.52	\$45.39	\$52.58	\$55.60	\$64.82
2016 Filed Traditional Rate	\$11.18	\$13.39	\$16.46	\$21.36	\$30.76	\$62.26	\$65.33	\$70.22

Appendix B – Lighting Rate Calculation Explanation

Normal rate calculation method

The rates for LED lights were determined using a standard revenue requirement approach, with carrying charges, distribution energy costs, and operation and maintenance expenses included as revenue requirements for the monthly rates. The carrying charges include depreciation expenses, return on capital using Company’s overall weighted cost of capital, income taxes and property taxes.

There are three main components that impact cost of overhead lighting rates: fixed charges (fixture costs and labor to install), energy costs, and O&M costs. The underground lighting rates have additional components not included in the overhead rates. Both LG&E and KU include the pole fixed charges (pole costs and labor to install). Along with the poles, LG&E includes trenching costs and KU includes costs of concrete bases. LKE currently depreciates lighting assets over approximately 25-26 years. Three items contribute to LKE’s LED rates being more expensive than traditional lighting rates. First, the LED fixture is much more expensive than the traditional lighting fixture. Second, the 2016 LED rates assumed a 13-year life of each LED fixture. In order to make the LED offerings fit with the standard lighting asset depreciation term, LKE adds the cost of a second LED fixture to the rates as an O&M expense. Finally, LKE’s fixture and labor costs that go into the assumptions for traditional lighting rates, primarily underground rates (pole fixed charges), have not kept up with present day costs. In the 2016 rate case filings, LKE requested to update each traditional lighting rate to reflect current material and labor costs. Ultimately, through settlement, LKE agreed to a 2% increase on all lighting rates while keeping those rates that would have decreased flat. See chart in Appendix A for comparison of current rate and the 2016 Filed Traditional Rates.

Upgrade rate calculations

The upgrade rate methodology now applies costs based on the Handy-Whitman index. The Handy Whitman Index provides cost trends for various industries. By applying the Index’s Cost Trends of Electric Utility Construction, an average cost calculation of facilities is made utilizing the years from 1973 to 2017. 1973 is the starting point because, according to the Index, the value of one dollar equaled one dollar beginning in 1973. Therefore, facilities such as aluminum poles, wire and labor are averaged using this index rather than allocating current costs, ultimately giving a “discount” to customers that simply convert from a traditional fixture to a LED fixture. By incorporating the lower facility costs into the rate calculations, the monthly rates for these type installations are reduced. Below is an example of the cost of a 30 foot aluminum pole used in the upgrade charge:

30 foot aluminum pole:

	2017 cost	Handy-Whitman factor 1973 / 2017	1973 cost	Handy-Whitman 1973 - 2017 average Street Lighting	Handy-Whitman factor 1973-2017 / 1973	Handy-Whitman 2017 Cost For Existing facilities
30 foot aluminum pole	\$746.60	0.1362	\$101.72	400.46	4.0046	\$407.34

The upgrade calculation is applied to existing underground-served lighting where a customer chooses to upgrade to LED Cobra Head, Colonial or Contemporary fixtures. Separate bill codes would be created to differentiate existing underground installations from new underground installations. Following is the breakdown of the fixtures to be offered:

Overhead							
Open Bottom							
	Yard Light	Cobra	Cobra	Cobra	Directional	Directional	Directional
Wattage	52.5	72	127	188.5	125	194	297
Lumen	5,350	7,400	15,000	26,000	15,000	25,700	37,100
Bill Code	393	390	391	392	xxx	xxx	xxx

New Underground							
	Cobra	Cobra	Cobra	Colonial	Contemporary	Contemporary	Contemporary
Wattage	72	127	188.5	66.5	74	171	281
Lumen	7,400	15,000	26,000	6,000	9,700	19,500	28,100
Bill Code	396	397	398	399	xxx	xxx	xxx

Existing Underground (upgrade rate)							
	Cobra	Cobra	Cobra	Colonial	Contemporary	Contemporary	Contemporary
Wattage	72	127	188.5	66.5	74	171	281
Lumen	7,400	15,000	26,000	6,000	9,700	19,500	28,100
Bill Code	xxx	xxx	xxx	xxx	xxx	xxx	xxx

Appendix C

<u>Alternative I - Totals for LKE</u>	
Total OH Lights	75,541
Total Hours to Complete	59,499
Total Labor Costs	\$8,600,000
Total Material Costs	\$32,770,000
Traffic Costs	\$700,000
Total Conversion Costs	\$42,070,000
Total years to complete	3.2
If # of crews =	11
Current Annual Revenue	\$13,820,000
(# of Lights * tariffed rate)	
Projected Annual LED revenue	\$13,820,000

<u>Alternative II - Totals for LKE</u>	
Total Lights	271,338
Total Hours to Complete	113,264
Total Labor Costs	\$29,200,000
Total Material Costs	\$93,800,000
Traffic Costs	\$1,923,108
Total Conversion Costs	\$125,100,000
Total years to complete	5.3
If # of crews =	25
Current Annual Revenue	\$51,000,000
(# of Lights * tariffed rate)	
Projected Monthly LED revenue	\$49,360,000

Appendix D

As shown below, LED's offer a benefit over HID fixtures when calculating an overall cost to own, operate, and maintain the fixture over the course of its depreciable life. The table below shows the cost to the company of each fixture over a 26 year life. The following were inputs for the analysis:

- Fixture Cost
 - For LED's there are two fixtures factored into analysis, the initial installation and a new fixture expected at year 15.
 - For HID's, there is only one fixture assumed.
- Energy Cost
 - For both type of fixtures this was calculated by taking current fixture wattage over a 4,000 hour burn year for 26 years and using the current Lighting Energy rate.
- O&M Expense
 - There is no expense factored or expected for the operation of LED fixtures. For HID's, this is assumed to be an expense every six years to replace bulbs and, in LG&E only, a pole painting cost every eight years.
- Timeframe
 - This analysis assumed all expected costs shown above over 26 years.

Table 1 – Summary of "fixture only" costs

		LG&E	KU			LG&E	KU
Open Bottom 5K Lumen					Cobra 8-9K Lumen		
	HID	\$ 1,457.76	\$ 1,147.41		HID	\$ 1,450.24	\$ 1,139.89
	LED	\$ 644.85	\$ 667.34		LED	\$ 799.76	\$ 830.31
		\$ 812.91	\$ 480.07			\$ 650.48	\$ 309.58
Cobra 14-20K Lumen					Cobra 23-50k Lumen		
	HID	\$ 2,316.86	\$ 2,059.55		HID	\$ 3,926.88	\$ 3,766.73
	LED	\$ 1,313.09	\$ 1,366.98		LED	\$ 1,947.54	\$ 2,027.52
		\$ 1,003.77	\$ 692.56			\$ 1,979.34	\$ 1,739.21
Colonial 5K Lumen							
	HID	\$ 1,494.64	\$ 1,184.29				
	LED	\$ 1,413.73	\$ 1,441.95				
		\$ 80.91	\$ (257.67)				

The Companies are offering 16 new LED offerings in the 2018 Rate Cases, totaling 24 LED offerings. These offerings constitute comparable LED fixtures for 99% of the fixtures in service today. On average, the proposed rates for these LED offerings are lower-cost to customers compared to proposed HID rates.

Weighted Average Price Difference Between LED and HID (positive = lower LED cost to customer)

	UG	OH	Total
KU	\$1.02	\$2.53	\$2.14
LG&E	(\$1.29)	\$2.17	\$1.28

LKE's customers will drive any conversion to LEDs, paying a monthly fee to convert a working HID light to an LED. The Companies propose to recover the conversion fee over five years. The proposed KU conversion fee is \$6.12 and the proposed LG&E conversion fee is \$7.49. As demonstrated below, the overwhelming majority of our customers will see their bill decrease at the end of the conversion fee term.

Total Number of Fixtures with Lower-Cost Comparable LED (% of Total with a Comparable LED)

	UG	OH	Total
KU	19,946 (44%)	116,275 (91%)	136,221 (79%)
LG&E	9,281 (26%)	52,468 (100%)	61,749 (70%)
Total	28,676 (36%)	168,743 (94%)	197,419(76%)

76% of LKE's HID fixtures will have a lower-cost comparable LED. If customers convert all fixtures to LEDs, using projected rates, customers will save \$7 million annually (KU: \$4.4 million, LG&E: \$2.6 million) after the conversion fee is paid.

LKE expects just under 10% of the fixtures in service today to have a combined monthly LED and conversion fee rate that is lower than the proposed HID rates. The customers receiving service for those fixtures are primarily private businesses or residents, however approximately 5,000 of those fixtures service various municipal and governmental customers.

Total Number of Fixtures where Combined Monthly LED and Conversion Rate is Lower-Cost to Customers

	UG	OH	Total
KU	4,732	18,367	23,099
LG&E	136	1,006	1,142
Total	4,868	19,373	24,241

Estimated Cost to Convert HID's where the Combined Monthly LED and Conversion Rate is Lower-Cost to Customers

	Materials	Labor	Total
KU	\$12,640,000	\$2,470,000	\$15,110,000
LG&E	\$800,000	\$110,000	\$910,000
Total	\$13,440,000	\$2,580,000	\$16,020,000

Materials are by far the most expensive component of any conversion. However, resource availability is a major concern that could drive up the cost of labor. The costs above are estimates using the blended hourly rate of LKE's lighting Business Partners. A conversion of all fixtures with a Lower-Cost Comparable LED is \$88 million (KU: \$58.5 million, LG&E: \$29.5 million). A cost of a conversion of all fixtures with a comparable LED is approximately \$116.5 million (KU: \$74.1 million, LG&E: \$42.4 million).

Municipal and governmental customers utilize LG&E and KU's lighting services to illuminate streets, parks, and parking lots with nearly 130,000 fixtures. The Companies' two largest lighting customers are the [REDACTED]. The charts below show the potential financial impacts to those customers.

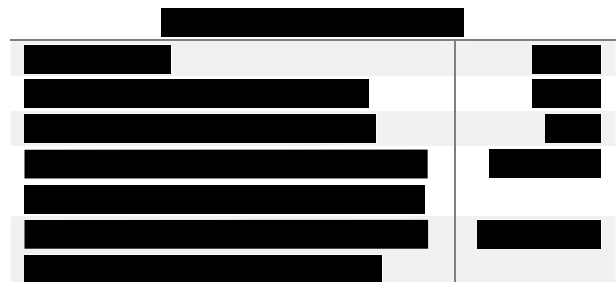

* All comparisons are of proposed LED rates to proposed HID rates. Proposed HID increase for LG&E is 2.97% and for KU is 7.09%.

Proposed LED Offerings	Proposed LED Lumen Bucket	Temperature	Lumens	Watts	Price	Lumens	Watts	Price	Primary Fixture Chosen
LED Cobra (70w equivalent)	2500-4000 lumens	3k	3000	22		3803	32		
LED Cobra (100-150w equivalent)	5500-8200 lumens	3k	8000	71		6800	73		
LED Cobra (200-250w equivalent)	13000-16500 lumens	3k	14000	122		16000	132		
LED Cobra (400w equivalent)	22000-29000 lumens	3k	23000	194		29000	233		
LED Acorn (70w-100w equivalent)	3500-6500 lumens	3k	5000	43		5000	40		
LED Colonial (70w-100w equivalent)	3500-6500 lumens	3k	5950	32		4100	44		
LED Open Bottom Kit (100w equivalent)	4500-6000 lumens	3k	5700	57		5000	48		
LED Contemporary (70w-100w equivalent)	4000-7000 lumens	3k	4600	44		6000	57		
LED Contemporary (150w equivalent)	8000-11000 lumens	3k	10500	87		10500	87		
LED Contemporary (200w-250w equivalent)	13500-16500 lumens	4k	16100	137		15000	143		
LED Contemporary (400w equivalent)	21000-28000 lumens	4k	27100	230		26000	220		
LED Contemproary (1000w MH equivalent)	45000-50000 lumens	4k	46900	398		45000	380		
LED Floodlight (70w-100w equivalent)	4000-6500 lumens	3k	4800	30		6000	51		
LED Floodlight (150w-200w equivalent)	14000-17500 lumens	3k	14600	96		17000	128		
LED Floodlight (400w equivalent)	22000-28000 lumens	4k	23900	175		23000	184		
LED Floodlight (1000w MH equivalent)	35000-50000 lumens	4k	38700	297		48000	371		

Co	Rate Code	Rate	Fixture Price	Wattage	LED Description	Co	Conversion Rate
LG&E	490	\$ 9.63			71 LS 490 OH LED Cobra 5500-8200	KU	\$ 6.12
LG&E	491	\$ 11.65			122 LS 491 OH LED Cobra 13000-16500	LGE	\$ 7.49
LG&E	492	\$ 13.65			144 LS 492 OH LED Cobra 22000-29000		
LG&E	493	\$ 8.74			48 LS 493 OH LED Open Bottom 4500-6000		
LG&E	LC1	\$ 8.40			22 LS LC1 OH LED Cobra 2500-4000		
LG&E	LF1	\$ 11.21			30 LS LF1 OH LED Flood 4500-6000		
LG&E	LF2	\$ 13.01			96 LS LF2 OH LED Flood 14000-17500		
LG&E	LF3	\$ 15.36			175 LS LF3 OH LED Flood 22000-28000		
LG&E	LF4	\$ 21.93			297 LS LF4 OH LED Flood 35000-50000		
LG&E	496	\$ 5.17			71 LS 496 UG LED Cobra 5500-8200		
LG&E	497	\$ 7.19			122 LS 497 UG LED Cobra 13000-16500		
LG&E	498	\$ 10.36			194 LS 498 UG LED Cobra 22000-29000		
LG&E	499	\$ 7.25			44 LS 499 UG LED Colonial 4000-7000		
LG&E	LA1	\$ 6.75			40 LS LA1 UG LED Acorn 4000-7000		
LG&E	LN1	\$ 6.74			57 LS LN1 UG LED Contemporary 4000-7000		
LG&E	LN2	\$ 7.85			87 LS LN2 UG LED Contemporary 8000-11000		
LG&E	LN3	\$ 9.56			143 LS LN3 UG LED Contemporary 13500-16500		
LG&E	LN4	\$ 13.86			220 LS LN4 UG LED Contemporary 21000-28000		
LG&E	LN5	\$ 20.91			380 LS LN5 UG LED Contemporary 45000-50000		
LG&E	LC2	\$ 3.94			22 LS LC2 UG LED Cobra 2500-4000		
LG&E	LF5	\$ 7.86			30 LS LF5 UG LED Flood 4500-6000		
LG&E	LF6	\$ 9.66			96 LS LF6 UG LED Flood 14000-17500		
LG&E	LF7	\$ 12.01			175 LS LF7 UG LED Flood 22000-28000		
LG&E	LF8	\$ 18.58			297 LS LF8 UG LED Flood 35000-50000		
LG&E	PL4	\$ 14.73			Decorative Smooth - Post Top		
LG&E	PL2	\$ 14.94			Contemporary (Short)		
LG&E	PL3	\$ 21.93			Contemporary (Tall)		
LG&E	PL1	\$ 30.99			Cobra - Ornamental		
LG&E	PL5	\$ 20.50			Historic Fluted - Post Top		
LG&E	LCON	\$ 7.49					
KU	390	\$ 10.23			71 LS 390 OH LED Cobra 6000-8200		
KU	391	\$ 12.34			122 LS 391 OH LED Cobra 13000-16500		
KU	392	\$ 15.67			194 LS 392 OH LED Cobra 22000-29000		
KU	393	\$ 8.80			48 LS 393 OH LED Open Bottom 4500-6000		
KU	KC1	\$ 8.95			22 LS KC1 OH LED Cobra 2500-4000		
KU	KF1	\$ 11.65			30 LS KF1 OH LED Flood 4500-6000		
KU	KF2	\$ 13.51			96 LS KF2 OH LED Flood 14000-17500		
KU	KF3	\$ 15.96			175 LS KF3 OH LED Flood 22000-28000		
KU	KF4	\$ 22.87			297 LS KF4 OH LED Flood 35000-50000		
KU	396	\$ 5.40			71 LS 396 UG LED Cobra 6000-8200		
KU	397	\$ 7.52			122 LS 397 UG LED Cobra 13000-16500		
KU	398	\$ 10.85			194 LS 398 UG LED Cobra 22000-29000		
KU	399	\$ 7.65			44 LS 399 UG LED Colonial 4000-7000		
KU	KA1	\$ 9.12			40 LS KA1 UG LED Acorn 4000-7000		
KU	KN1	\$ 7.09			57 LS KN1 UG LED Contemporary 4000-7000		
KU	KN2	\$ 8.25			87 LS KN2 UG LED Contemporary 8000-11000		
KU	KN3	\$ 10.03			143 LS KN3 UG LED Contemporary 13500-16500		
KU	KN4	\$ 14.55			220 LS KN4 UG LED Contemporary 21000-28000		
KU	KN5	\$ 21.95			380 LS KN5 UG LED Contemporary 45000-50000		
KU	KC2	\$ 4.13			22 LS KC2 UG LED Cobra 2500-4000		
KU	KF5	\$ 8.45			30 LS KF5 UG LED Flood 4500-6000		
KU	KF6	\$ 10.31			96 LS KF6 UG LED Flood 14000-17500		
KU	KF7	\$ 12.75			175 LS KF7 UG LED Flood 22000-28000		
KU	KF8	\$ 19.67			297 LS KF8 UG LED Flood 35000-50000		
KU	PK1	\$ 12.49			Cobra - Ornamental		
KU	PK3	\$ 8.25			Decorative Smooth - Post Top		
KU	PK2	\$ 12.00			Contemporary		
KU	PK4	\$ 15.48			Historic Fluted - Post Top		
KU	KCON	\$ 6.12					
0	0	\$ -		0			

Confidential Information Redacted

Total Fixtures With a Comparable LED				Cost to Convert All Fixtures to LED			
	UG	OH	Total		Materials	Labor	Total
KU	44,885	127,905	172,790	KU	\$54,610,000	\$19,580,000	\$74,190,000
LG&E	35,463	52,468	87,931	LG&E	\$31,230,000	\$11,170,000	\$42,400,000
Total	80,348	180,373	260,721	Total	\$85,840,000	\$30,750,000	\$116,590,000

Weighted Average Price Difference Between LED and HID (postive = lower LED cost to customer)

	UG	OH	Total
KU	\$1.02	\$2.53	\$2.14
LG&E	(\$1.29)	\$2.17	\$1.28

Total Number of HID's with Lower-Cost Comparable LED

Total Number of HID's with Lower-Cost Comparable LED				Cost to Convert HID's with Lower-Cost Comparable LED					
	UG	OH	Total		Materials	Labor	Total		
KU	19,946	116,275	136,221	44%	91%	79% KU	\$41,930,000	\$16,840,000	\$58,770,000
LG&E	9,281	52,468	61,749	26%	100%	70% LG&E	\$21,270,000	\$8,070,000	\$29,340,000
Total	29,227	168,743	197,970	36%	94%	76% Total	\$63,200,000	\$24,910,000	\$88,110,000

Total Number of HID's Where the Combined Montly LED and conversion rate is Lower-Cost to the Customer

	UG	OH	Total
KU	4,732	18,367	23,099
LG&E	136	1,006	1,142
Total	4,868	19,373	24,241
KU Cust			
Total Munis/Gov't	1297	3690	4987
Total private	3,435	14,677	18,112
LG&E Cust			
Muni/Gov't	35	39	74
Private	101	967	1,068

Cost to Convert HID's Where the Combined Monthly LED and Conversion Rate is Lower-Cost to the Customer

	Material Costs	Labor Costs	Total Costs
KU	\$12,640,000	\$2,470,000	\$15,110,000
LG&E	\$800,000	\$110,000	\$910,000
Total	\$13,440,000	\$2,580,000	\$16,020,000

If HID's converted to LED, where LED rate is less expensive - not including conversion fee

	Projected HID Revenue W/ Cheaper LED			Projected LED Revenue w/ Cheaper LED			Savings to Customers Switching to LEDs			Annual Totals
	UG	OH	Total	UG	OH	Total	UG	OH	Total	
KU	\$530,677.62	\$1,608,976.73	\$2,139,654.35	\$429,478.01	\$1,277,602.35	\$1,707,080.36	\$101,199.61	\$331,374.38	\$432,573.99	\$5,190,887.88
LG&E	\$245,350.76	\$918,967.38	\$1,164,318.14	\$214,439.89	\$640,877.62	\$855,317.51	\$30,910.87	\$278,089.76	\$309,000.63	\$3,708,007.56
Total	\$776,028.38	\$2,527,944.11	\$3,303,972.49	\$643,917.90	\$1,918,479.97	\$2,562,397.87	\$132,110.48	\$609,464.14	\$741,574.62	\$8,898,895.44
<u>Annual Totals</u>	<u>\$9,312,340.56</u>	<u>\$30,335,329.33</u>	<u>\$39,647,669.88</u>	<u>\$7,727,014.80</u>	<u>\$23,021,759.64</u>	<u>\$30,748,774.44</u>	<u>\$1,585,325.76</u>	<u>\$7,313,569.69</u>	<u>\$8,898,895.44</u>	

If All HID's converted to LED

	Projected HID Revenue Overall			Projected LED Revenue Overall			Monthly Savings to Customers if Switching All Lights to LEDs			
	UG	OH	Total	UG	OH	Total	UG	OH	Total	Annual Totals
KU	\$895,035.49	\$1,736,929.56	\$2,631,965.05	\$849,514.34	\$1,412,960.12	\$2,262,474.46	\$45,521.15	\$323,969.44	\$369,490.59	\$4,433,887.05
LG&E	\$843,148.14	\$918,967.38	\$1,762,115.52	\$900,687.87	\$640,877.62	\$1,541,565.49	(\$57,539.73)	\$278,089.76	\$220,550.03	\$2,646,600.42
Total	\$1,738,183.64	\$2,655,896.94	\$4,394,080.57	\$1,750,202.21	\$2,053,837.74	\$3,804,039.95	(\$12,018.57)	\$602,059.20	\$590,040.62	\$7,080,487.47
Annual Total	\$20,858,203.64	\$31,870,763.24	\$52,728,966.87	\$21,002,426.52	\$24,646,052.88	\$45,648,479.40	-\$144,222.88	\$7,224,710.36	\$7,080,487.47	

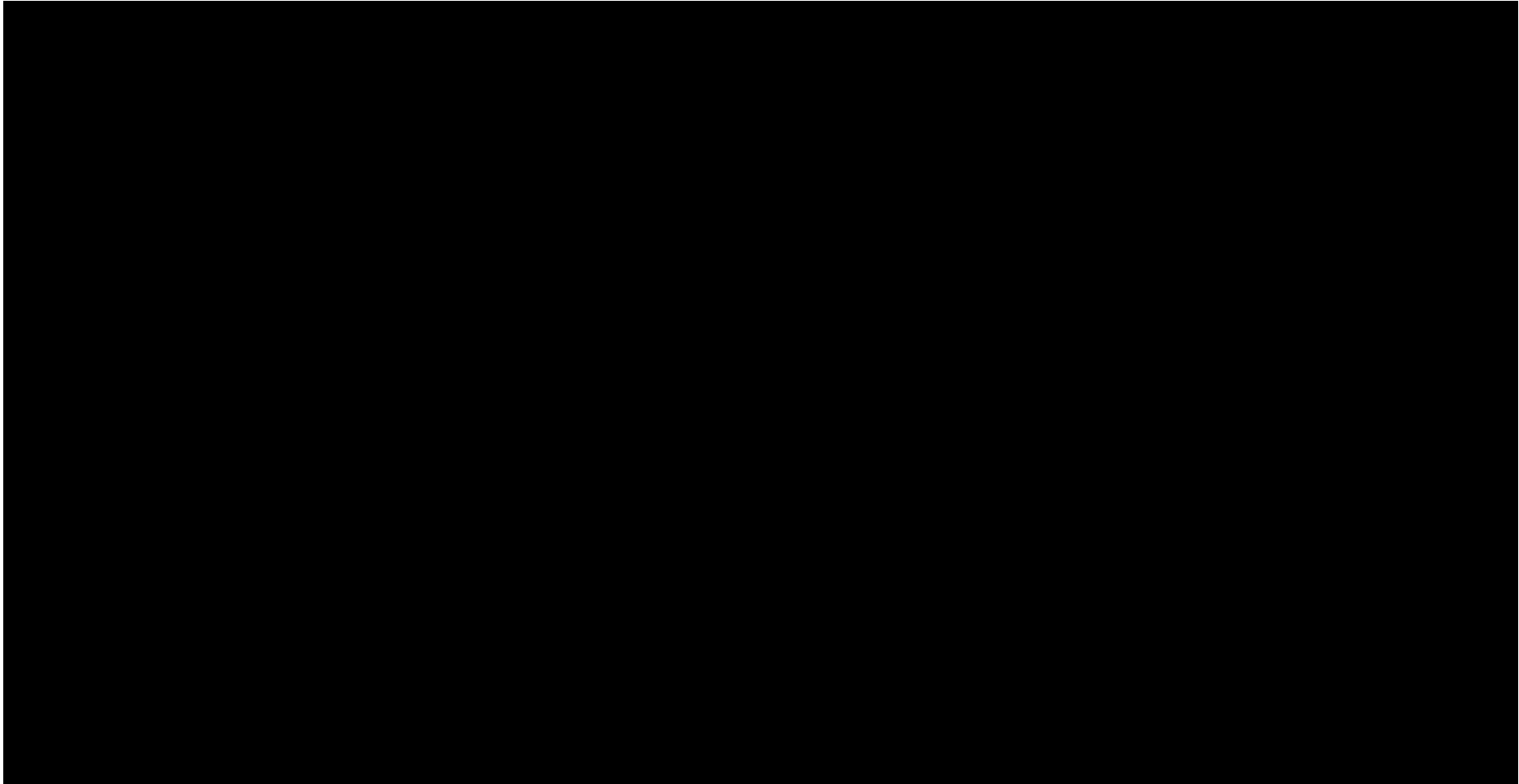

Replace all lights with cheaper LED rate

<u>Kentucky Utilities -Customer Driven Replacement</u>	
Street Lights	58,890
Area lights	77,331
Total Lights	136,221
Hours to complete Street Lights	44,168
Hours to complete Area Lights	77,331
Total Hours to Complete	121,499
St Light Labor Costs (2 man crew)	\$7,410,000
Area Lights (1 man crew)	\$6,490,000.00
Total Labor Costs	\$15,800,000
(using max hrly rate = \$83.87)	
Material Costs	\$ 41,930,000
Total Material Costs	\$ 41,930,000
Traffic Costs	\$ 1,040,000
(Necessary on 65% of lights - ST)	
Total Conversion Costs	\$ 50,380,000
Total years to complete	4.9
Where # of crews =	13

<u>LG&E - Customer Driven Replacement</u>	
Street Lights	37,634
Area lights	24,115
Total Lights	61,749
Hours to complete Street Lights	28,226
Hours to complete Area Lights	24,115
Total Hours to Complete	52,341
St Light Labor Costs (2 man crew)	\$4,740,000
Area Lights (1 man crew)	\$2,030,000
Total Labor Costs	\$7,400,000
(using max hrly rate = \$83.87)	
Light Material Costs	\$ 21,270,000
Total Material Costs	\$ 21,270,000
Traffic Costs	\$ 670,000
(Necessary on 65% of lights - ST)	
Total Conversion Costs	\$ 29,340,000
Total years to complete	4.5
Where # of crews =	6

<u>Alternative I - Totals for LKE</u>	
Total OH Lights	197,970
Total Hours to Complete	173,839
Total Labor Costs	\$14,810,000
Total Material Costs	\$63,200,000
Traffic Costs	\$1,710,000
Total Conversion Costs	\$79,720,000
Total years to complete	4.9
If # of crews =	19

Replace all lights where Conversion Cheaper to Customer

<u>Kentucky Utilities -Customer Driven Replacement</u>	
Street Lights	3,486
Area lights	19,613
Total Lights	23,099
Hours to complete Street Lights	2,615
Hours to complete Area Lights	19,613
Total Hours to Complete	22,228
St Light Labor Costs (2 man crew)	\$440,000
Area Lights (1 man crew)	\$1,650,000.00
Total Labor Costs	\$2,400,000
(using max hrly rate = \$83.87)	
Material Costs	\$ 12,640,000
Total Material Costs	\$ 12,640,000
Traffic Costs	\$ 70,000
(Necessary on 65% of lights - ST)	
Total Conversion Costs	\$ 13,150,000
Total years to complete	1.9
Where # of crews =	6

<u>LG&E - Customer Driven Replacement</u>	
Street Lights	25
Area lights	1,117
Total Lights	1,142
Hours to complete Street Lights	19
Hours to complete Area Lights	1,117
Total Hours to Complete	1,136
St Light Labor Costs (2 man crew)	\$10,000
Area Lights (1 man crew)	\$100,000
Total Labor Costs	\$100,000
(using max hrly rate = \$83.87)	
Light Material Costs	\$ 800,000
Total Material Costs	\$ 800,000
Traffic Costs	\$ 10,000
(Necessary on 65% of lights - ST)	
Total Conversion Costs	\$ 910,000
Total years to complete	0.6
Where # of crews =	1

<u>Alternative I - Totals for LKE</u>	
Total OH Lights	24,241
Total Hours to Complete	23,363
Total Labor Costs	\$540,000
Total Material Costs	\$13,440,000
Traffic Costs	\$80,000
Total Conversion Costs	\$14,060,000
Total years to complete	1.9
If # of crews =	7

System Wide Conversion of all HID's with comparable LED

Kentucky Utilities - Total Conversion to LED	
Street Lights	83,885
Area lights	88,905
Total Lights	172,790
Hours to complete Street Lights	62,914
Hours to complete Area Lights	88,905
Total Hours to Complete	151,819
St Light Labor Costs (2 man crew)	\$10,600,000
Area Lights (1 man crew)	\$7,456,462.35
Total Labor Costs	\$18,100,000
Total Material Costs	\$ 54,610,000
(fixture costs + long-life PEC)	
Traffic Costs	\$ 1,480,000.00
(Necessary on 35% of lights - ST)	
Total Conversion Costs	\$ 74,200,000.00
Total years to complete	5.3
Where # of crews =	15

LG&E - Total Conversion to LED	
Street Lights	60,531
Area lights	29,077
Total Lights	89,608
Hours to complete Street Lights	45,398
Hours to complete Area Lights	29,077
Total Hours to Complete	74,475
St Light Labor Costs (2 man crew)	\$7,700,000
Area Lights (1 man crew)	\$2,438,687.99
Total Labor Costs	\$10,100,000
Total Material Costs	\$ 31,230,000
(fixture costs + long-life PEC)	
Traffic Costs	\$ 1,070,000.00
(Necessary on 35% of lights - ST)	
Total Conversion Costs	\$ 42,400,000.00
Total years to complete	4.8
Where # of crews =	8

Totals for LKE	
Total Street Lights	144,416
Total Area Lights	117,982
Total Lights	262,398
Total Hours to Complete	108,312
(45 minutes per light)	
Total Labor Costs	\$28,200,000
(using max hrly rate = \$83.87)	
Total Material Costs	\$85,840,000
(fixture costs + long-life PEC)	
Traffic Costs	\$2,550,000
(Necessary on 35% of lights - ST)	
Total Conversion Costs	\$116,600,000
Total years to complete	5.3
If # of crews =	23

2017

YTD Actual	SpendType	Code		Capital Total	OM	OM Total	Grand Total
Ops Center	Capital	NEW BUSINESS/STREET LIGHTING	REPAIR / REP DEF ST LIGHTING		REPAIR / REP DEF ST LIGHTING		
DANOC	\$	243,788	\$ 202,923	\$ 446,710	\$	43,290	\$ 490,000
EAROC	\$	518,072	\$ 435,199	\$ 953,271	\$	7,974	\$ 961,245
ELIOC	\$	147,487	\$ 236,146	\$ 383,633	\$	2,169	\$ 385,802
LEXOC	\$	1,661,913	\$ 971,228	\$ 2,633,142	\$	385,559	\$ 3,018,700
LGEOCE	\$	1,828,434	\$ 3,011,604	\$ 4,840,037	\$	404,389	\$ 5,244,426
LONOC	\$	287,517	\$ 365,040	\$ 652,557	\$	6,365	\$ 658,923
MAYOC	\$	291,443	\$ 236,121	\$ 527,565	\$	28,207	\$ 555,772
NOROC	\$	124,367	\$ 56,042	\$ 180,409	\$	92,165	\$ 272,574
PINOC	\$	270,891	\$ 113,327	\$ 384,217	\$	70,263	\$ 454,480
RICOC	\$	339,870	\$ 288,271	\$ 628,141	\$	4,306	\$ 632,447
SHEOC	\$	115,421	\$ 262,850	\$ 378,271	\$	5,763	\$ 384,035
Grand Total	\$	5,829,203	\$ 6,178,751	\$ 12,007,954	\$	1,050,449	\$ 13,058,403

2016

YTD Actual	SpendType	Code		Capital Total	OM	OM Total	Grand Total
Ops Center	Capital	NEW BUSINESS/STREET LIGHTING	REPAIR / REP DEF ST LIGHTING		REPAIR / REP DEF ST LIGHTING		
DANOC	\$	289,550	\$ 253,407	\$ 542,957	\$	37,733	\$ 580,690
EAROC	\$	528,294	\$ 615,557	\$ 1,143,851	\$	4,659	\$ 1,148,509
ELIOC	\$	248,676	\$ 205,992	\$ 454,669	\$	3,839	\$ 458,508
LEXOC	\$	1,619,653	\$ 694,797	\$ 2,314,450	\$	522,883	\$ 2,837,332
LGEOCE	\$	1,678,915	\$ 3,647,036	\$ 5,325,951	\$	430,106	\$ 5,756,057
LONOC	\$	318,648	\$ 293,180	\$ 611,828	\$	41,236	\$ 653,064
MAYOC	\$	348,561	\$ 254,510	\$ 603,070	\$	34,260	\$ 637,331
NOROC	\$	97,138	\$ 80,214	\$ 177,353	\$	90,756	\$ 268,109
PINOC	\$	249,904	\$ 74,615	\$ 324,519	\$	81,174	\$ 405,693
RICOC	\$	327,283	\$ 238,539	\$ 565,823	\$	3,396	\$ 569,219
SHEOC	\$	185,976	\$ 251,160	\$ 437,136	\$	21,974	\$ 459,110
Grand Total	\$	5,892,599	\$ 6,609,007	\$ 12,501,606	\$	1,272,015	\$ 13,773,621

2015

YTD Actual	SpendType	Code		Capital Total	OM	OM Total	Grand Total
Ops Center	Capital	NEW BUSINESS/STREET LIGHTING	REPAIR / REPLACE DEF ST LIGHTING		REPAIR / REP DEF ST LIGHTING		
DANOC	\$	286,325	\$ 244,892	\$ 531,216	\$	21,859	\$ 553,076
EAROC	\$	444,438	\$ 664,666	\$ 1,109,104	\$	3,783	\$ 1,112,887
ELIOC	\$	279,838	\$ 246,113	\$ 525,951	\$	182	\$ 526,133
LEXOC	\$	1,550,254	\$ 828,128	\$ 2,378,382	\$	528,008	\$ 2,906,389
LGEOCE	\$	2,174,452	\$ 3,718,190	\$ 5,892,642	\$	420,572	\$ 6,313,214
LONOC	\$	226,824	\$ 324,505	\$ 551,329	\$	19,874	\$ 571,202
MAYOC	\$	358,424	\$ 257,906	\$ 616,330	\$	23,587	\$ 639,917
NOROC	\$	88,618	\$ 78,390	\$ 167,008	\$	102,505	\$ 269,513
PINOC	\$	215,971	\$ 179,464	\$ 395,436	\$	82,772	\$ 478,207
RICOC	\$	288,360	\$ 252,937	\$ 541,297	\$	4,801	\$ 546,098
SHEOC	\$	178,078	\$ 238,050	\$ 416,127	\$	12,854	\$ 428,981
Grand Total	\$	6,091,581	\$ 7,033,239	\$ 13,124,821	\$	1,220,797	\$ 14,345,618

Lamp Usage - Both Companies		2017	2016	2015	2014	2013
Lamp	LAMP, HPS, 1000W	949519	0	44	66	27
Lamp	LAMP, HPS, 100W, 9500L	1186386	4953	5509	5812	5280
Lamp	LAMP, HPS, 100W, 9500L	7001345	11435	12920	13436	12764
Lamp	LAMP, HPS, 150W, 16000L	1186394	1465	1909	1666	1878
Lamp	LAMP, HPS, 200W, 22000L	7001346	2234	3317	2958	2624
Lamp	LAMP, HPS, 250W, 100V, 27500L	1186401	2481	3359	2872	2720
Lamp	LAMP, HPS, 400W, 100V, 50000L	1186419	3381	4881	5105	4916
Lamp	LAMP, HPS, 400W, 100V, 50000L	7001347	2397	3000	3421	2417
Lamp	LAMP, HPS, 50W, 4000L, CLEAR/ECO, MOGUL	7001343	1713	2403	2124	1696
Lamp	LAMP, HPS, 70W, 5800L	454443	358	373	519	276
Lamp	LAMP, HPS, 70W, 5800L	7001344	3432	3458	3394	3130
Lamp	LAMP, MH, 1000W, 110000L	7005980	830	1382	1194	943
Lamp	LAMP, MH, 175W, 14000L	7005978	186	286	246	162
Lamp	LAMP, MH, 400W, 36000L	7005979	780	1288	1820	1632
Lamp	LAMP, PULSE START MH, 150W, MEDIUM BASE	3005449	128	148	234	211
Lamp	LAMP, PULSE START MH, 350W, MOGUL BASE	3005450	525	449	443	308
Lamp	LAMP, MV, 175W, 8000L, DELUXE WHITE	1186360	312	348	576	378
Lamp	LAMP, MV, 175W, 8000L, DELUXE WHITE	7001348	492	661	552	540
Lamp	LAMP, MV, 250W, 13000L, DELUXE WHITE	1186378	826	765	900	906
Lamp	LAMP, MV, 250W, 13000L, DELUXE WHITE	7001349	144	191	59	0
Lamp	LAMP, MV, 400W, 25000L, DELUXE WHITE	1186427	731	871	910	684
Lamp	LAMP, MV, 400W, 25000L, DELUXE WHITE	7001350	282	418	282	162
			39085	47936	48567	43693
			14%	18%	18%	16%
						46636
						17%

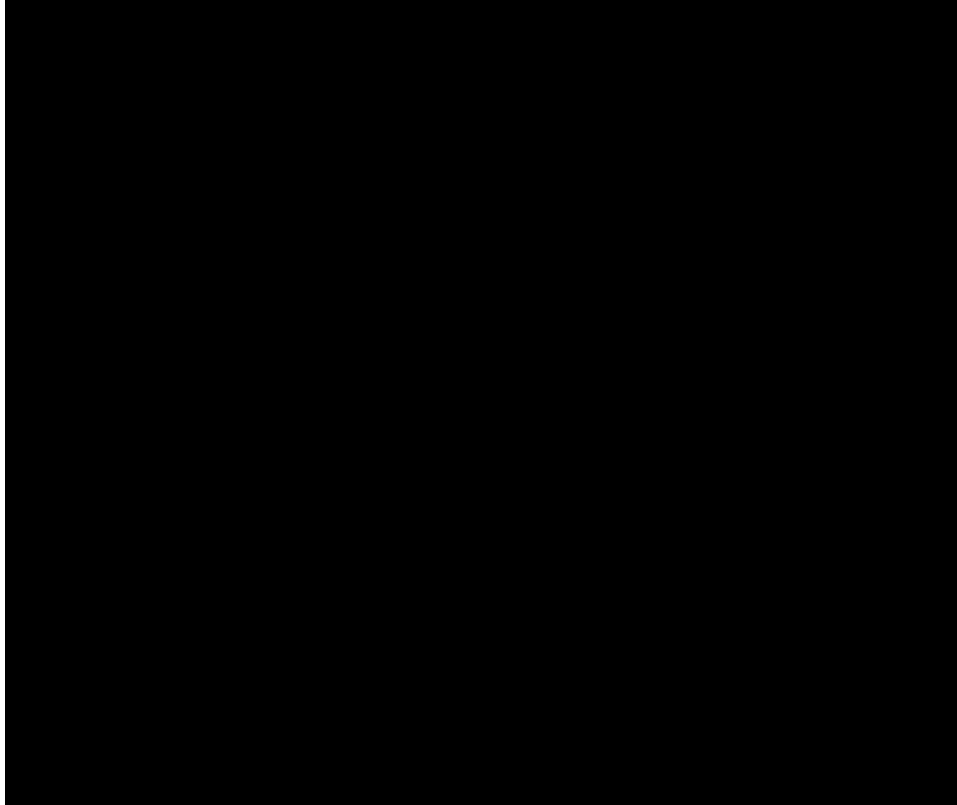

Traffic Control Assumption Necessary for 35% of all lights

Total working hrs per year per man 1920
40 hr work week, 48 weeks per year

For unknown Fix Costs - average costs used

Admin and back-office costs & process currently not accounted for

Maintenance Costs

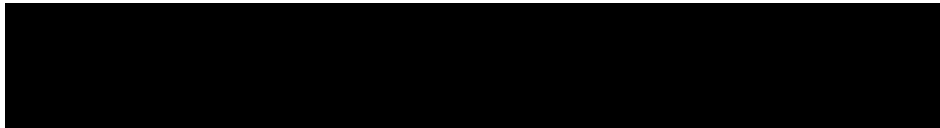

Confidential Information Redacted

Table with columns: Comman, Line code, descro, RLS, # Features, Monthly Rate, Como LED code, Pole, Como LED S, Diff, Weighted Total, 1 = cheaper w/c 1 = more expensive, UG Lites, Historic Pole, Current Monthly Rev, Annual Rev, Future Cost, Total Future Costs + PEC, Potential Monthly LED Rev, Projected HIR rates, Projected Monthly HIR A Area list, HD wattage, near HD watt, Como LED wattage, Como LED wattage. Rows include items like KUUM 404 404, KUUM 409 409, KUUM 411 411, etc.



GE Evolve™
LED Roadway Lighting
ERL1-ERLH-ERL2



GE Evolve™
LED Roadway Lighting
ERL1-ERLH-ERL2



The **Evolve** LED Roadway Luminaire is optimized for customers requiring a LED solution for local, collector and major roadways. GE's unique reflective optics are designed to optimize application efficiency and minimize glare. The modern design incorporates the heat sink directly into the unit for heat transfer to prolong LED life. This reliable unit has a 100,000 hour design life, significantly reducing maintenance needs and expense over the life of the fixture. This efficient solution lowers energy consumption compared to a traditional HID fixture for additional operating cost savings.

Features:

- Optimized roadway photometric distributions
- **Evolve™** light engine consisting of reflective technology designed to optimize application efficiency and minimize glare
- 70 CRI at 2700K, 3000K and 4000K typical.
- -40°C to 50°C UL Ambient Typical.
- ULOR = 0 (zero uplight)
- Designed & Assembled in USA

Applications:

- Local Roadways
- Collector Roadways
- Major Roadway/Streets



Compatible with **LightGrid™** Outdoor Wireless Control System



To learn more about **GE Evolve LED Roadway Lighting**, go to: www.currentbyge.com



GE Evolve™
LED Roadway Lighting
 ERL1-ERLH-ERL2



Project name _____
 Date _____
 Type _____

Typical Specifications: ERL1-ERLH-ERL2

LED & Optical

- **Output Range:** 1900 – 30000 lm
- **Photometric Options:** Type II Narrow, Type II Wide, Type III, Type IV
- **System Efficacy:** 100 - 145 LPW
- **CCT:** 2700K, 3000K, 4000K; High brightness LEDs @ 70 CRI

Lumen Maintenance Tables

Projected Lxx per IES TM-21 at 25°C for reference:

ERL1 LUMEN OUTPUT CODES	LXX(10K)@HOURS		
	25,000 HR	50,000 HR	100,000 HR
02,03,04,05,06	L96	L95	L91
07,08,09	L95	L91	L84
10	L89	L80	L64

ERLH LUMEN OUTPUT CODES	LXX(10K)@HOURS		
	25,000 HR	50,000 HR	100,000 HR
10, 11	L97	L96	L94
13, 14	L95	L93	L88
15, 16	L94	L91	L85

ERL2 LUMEN OUTPUT CODES	LXX(10K)@HOURS		
	25,000 HR	50,000 HR	100,000 HR
16, 18, 19, 21, 23	L96	L94	L91
25, 27, 28	L95	L93	L88
30	L95	L93	L87

Note: Projected Lxx based on LM80 (10,000 hour testing). DOE Lighting Facts Verification Testing Tolerances apply to initial luminous flux and lumen maintenance measurements.

Electrical

- **Input Voltage:** 120-277 volt and 347-480 volt
- **Input Frequency:** 50/60Hz
- **Power Factor (PF)*:** >90%
- **Total Harmonic Distortion (THD)*:** <20%

*Power factor and THD tolerance exceptions: ERL1 "02" Lumen output: PF and THD within tolerances above only at 120 volt. ERL1 "03" Lumen output: @120 volt PF-0.89; @ 480 volt THD-26% ERL1 "04" Lumen output: @480 volt THD-22%

Ratings

- **Surge Protection:** per ANSI C136.2-2015:
(Driver Internal):
 - 6kV/3kA "Basic: (120 Strikes)" - Standard on ERL1 (02-06)
 - 10kV/5kA "Enhanced: (40 Strikes)" - Standard on ERL1 (07 - 10), ERLH, ERL2**(Additional Separate Secondary SPD)**
 - 10kV/5kA "Enhanced: (40 Strikes)" - Option "R"
 - 20kV/10kA "Elevated" (40 Strikes) - Option "T"
- **Safety:** UL/cUL Listed. UL 1598 listed, suitable for wet locations (UL/cUL)
- **Environmental:** Compliant with the materials restrictions of RoHS
- **EMI:** Title 47 CFR Part 15 Class A
- **Vibration:** 3G per ANSI C136.31-2010
- LM-79 testing in accordance with IESNA Standards
- Std. Optical enclosure rated per ANSI C136.25-2009:
 - ERL1/ERLH/ERL2 = IP65, Optional: IP66

Operating Temperature:

PRODUCT ID	LUMEN OUTPUT	AMBIENT READING
ERL1	02-10	-40°C to 50°C
ERLH	10-11, 13	-40°C to 50°C
ERLH	14-16	-40°C to 45°C
ERL2	16-28	-40°C to 50°C
ERL2	30	-40°C to 45°C

Delayed start may be experienced < -35°C

Construction & Finish

- **Housing:**
 - Die Cast Enclosure
 - Casting-integral heat sink for maximum heat transfer
- **Lensing:** Impact resistant tempered glass, standard
- **Paint:** Corrosion resistant polyester powder painted, minimum 2.0 mil. thickness.
 - Standard Colors: Dark Bronze, Black, & Gray
 - RAL & custom colors available
 - Optional coastal finish available.
- **Weight:** 12.4lbs (5.6kg) – 24lbs (10.9kg)

Warranty

- **System Warranty:** 5 Year Standard, 10 Year Optional

Controls

- **Dimming:**
 - Standard: 0-10V; Optional: DALI (120-277V Only)
- **Sensors:**
 - Photo electric sensors (PE) available.
- LightGrid™ compatible

Mounting

- Slipfitter with +/- 5 degree of adjustment for leveling.
- Integral die cast mounting pipe stop.
- Adjustable for 1.25 in. or 2 in. mounting pipe.

Suggested HID Replacement Lumen Levels

- ~4,000–5,000 lumens to replace 100W HPS Cobra-head
- ~7,000–8,800 lumens to replace 150W HPS Cobra-head
- ~8,500–11,500 lumens to replace 200W HPS Cobra-head
- ~11,500–14,000 lumens to replace 250W HPS Cobra-head
- ~21,000–30,000 lumens to replace 400W HPS Cobra-head

Note: Actual replacement lumens may vary based upon mounting height, pole spacing, design criteria, etc.

PREVIOUS	DESCRIPTION	CURRENT	DESCRIPTION**
A1, B1	Extra Narrow/Narrow Asymmetric	A3	Type II Narrow
C1, E1	Asymmetric Short/Medium	B3	Type II Wide
D1, G1	Asymmetric Forward/Extra Wide	C3	Type III
F1	Asymmetric Wide	D3	Type IV
		E3	Type II Enhanced Back Light

**The information above is designed to provide a guideline to select the correct luminaire for a roadway application. The best and most accurate way to ensure the proper design is do a lighting layout Utilizing AGI.

Photometrics:

Evolve™ LED Streetlight (ERL1)

ERL1

Type II Narrow
(05A340)

5,000 Lumens
4000K

ERL1_05A340____.IES

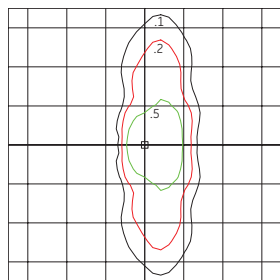

Grid Distance in Units of Mounting Height at 30'
Initial Footcandle Values at Grade

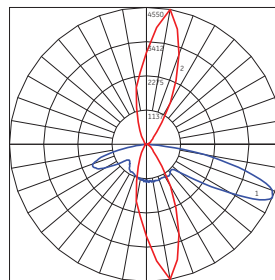

— Vertical plane through horizontal angle of Max. Cd at 80°
— Horizontal cone through vertical angle of Max. Cd at 67°

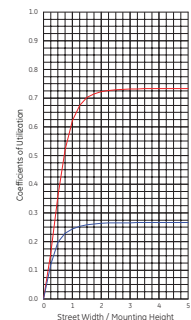

ERL1

Type II Wide
(05B340)

5,000 Lumens
4000K

ERL1_05B340____.IES

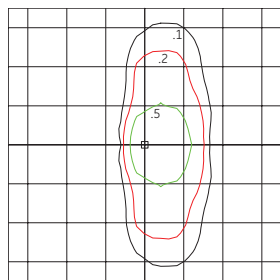

Grid Distance in Units of Mounting Height at 30'
Initial Footcandle Values at Grade

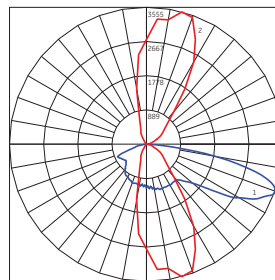

— Vertical plane through horizontal angle of Max. Cd at 75°
— Horizontal cone through vertical angle of Max. Cd at 69°

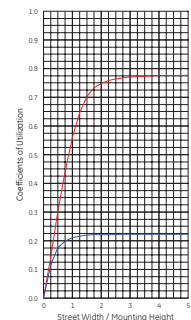

ERL1

Type III
(05C340)

5,000 Lumens
4000K

ERL1_05C340____.IES

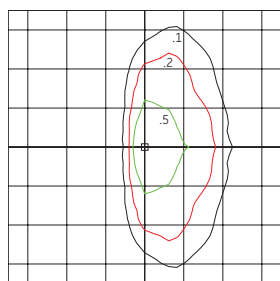

Grid Distance in Units of Mounting Height at 30'
Initial Footcandle Values at Grade

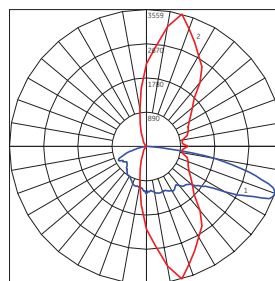

— Vertical plane through horizontal angle of Max. Cd at 75°
— Horizontal cone through vertical angle of Max. Cd at 70°

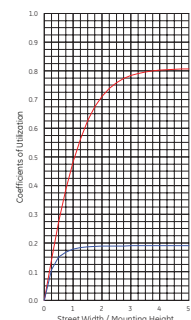

ERL1

Type IV
(05D340)

5,000 Lumens
4000K

ERL1_05D340____.IES

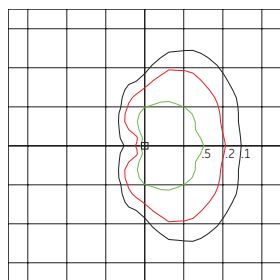

Grid Distance in Units of Mounting Height at 30'
Initial Footcandle Values at Grade

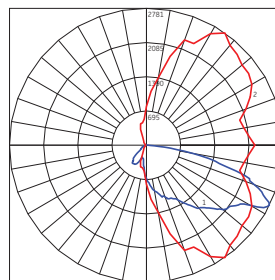

— Vertical plane through horizontal angle of Max. Cd at 55°
— Horizontal cone through vertical angle of Max. Cd at 64°

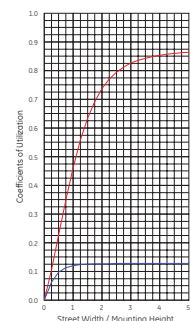

ERL1

Type II Enhanced Back Light
(05E340)

5,000 Lumens
4000K

ERL1_05E340____.IES

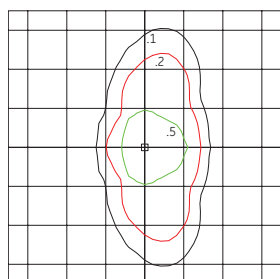

Grid Distance in Units of Mounting Height at 30'
Initial Footcandle Values at Grade

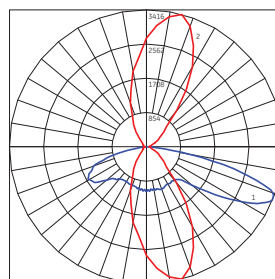

— Vertical plane through horizontal angle of Max. Cd at 75°
— Horizontal cone through vertical angle of Max. Cd at 67°

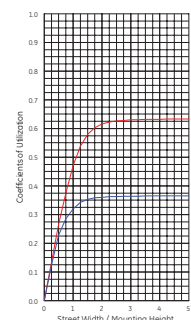

GE Evolve™
LED Roadway Lighting
ERL1-ERLH-ERL2



Project name _____
Date _____
Type _____

ERLH

PROD. ID	VOLTAGE	LUMEN OUTPUT	DISTRIBUTION*	CCT	CONTROLS	COLOR	OPTIONS
E = Evolve R = Roadway L = Local H = High Output	0 = 120-277V* 1 = 120 2 = 208 3 = 240 4 = 277 5 = 480 D = 347 H = 347-480*	10 11 13 14 15 16 See Table	A3 = Type II Narrow B3 = Type II Wide C3 = Type III D3 = Type IV E3 = Type II Enhanced Back Light See Table	30 = 3000K 40 = 4000K Select 3000K CCT for IDA approved units.	A = ANSI C136.41 7-pin D = ANSI C136.41 7-pin with Shorting Cap E = ANSI C136.41 7-pin with non-Dimming PE Control.* *PE Control Only available for 120-277V or 480V Discrete. Not available for 347-480V or 347V Discrete. NOTE: Dimming controls wired for 0-10V standard unless DALI option "U" requested.	GRAY = Gray BLCK = Black DKBZ = Dark Bronze	A = 4 Bolt Slipfitter † F = Fusing G = Internal Bubble Level I = IP66 Optical L = Tool-Less Entry R = Secondary 10kV/5kA SPD U = DALI Programmable + ^ X = Single Package # Y = Coastal Finish * XXX = Special Options † Contact manufacturer for Lead-Time. # "X" option provides single pack box per fixture. Std Packaging = 20 units per Magna pak container. * Recommended for installations within 750 ft. from the coast. Contact Factory for Lead-Time. + Compatible with LightGrid 2.0 nodes. ^ Not available in 347V, 480V or 347-480V.

LUMEN OUTPUT	DISTRIBUTION	TYPICAL INITIAL LUMENS		TYPICAL SYSTEM WATTAGE		BUG RATING		IES FILE NUMBER			
		4000K	3000K	120-277V	347-480V	4000K	3000K	4000K	3000K		
10	A3	10000	9600	82	82	B2-U0-G2	B2-U0-G2	ERLH_10A340	.IES	ERLH_10A330	.IES
	B3					B2-U0-G2	B2-U0-G2	ERLH_10B340	.IES	ERLH_10B330	.IES
	C3					B2-U0-G3	B2-U0-G2	ERLH_10C340	.IES	ERLH_10C330	.IES
	D3					B1-U0-G3	B1-U0-G2	ERLH_10D340	.IES	ERLH_10D330	.IES
	E3					B3-U0-G3	B3-U0-G3	ERLH_10E340	.IES	ERLH_10E330	.IES
11	A3	11500	11000	98	98	B3-U0-G3	B2-U0-G2	ERLH_11A340	.IES	ERLH_11A330	.IES
	B3					B3-U0-G3	B2-U0-G2	ERLH_11B340	.IES	ERLH_11B330	.IES
	C3					B2-U0-G3	B2-U0-G3	ERLH_11C340	.IES	ERLH_11C330	.IES
	D3					B1-U0-G3	B1-U0-G2	ERLH_11D340	.IES	ERLH_11D330	.IES
	E3					B3-U0-G3	B3-U0-G3	ERLH_11E340	.IES	ERLH_11E330	.IES
13	A3	13000	12500	111	111	B3-U0-G3	B3-U0-G3	ERLH_13A340	.IES	ERLH_13A330	.IES
	B3					B2-U0-G3	B2-U0-G3	ERLH_13B340	.IES	ERLH_13B330	.IES
	C3					B2-U0-G3	B2-U0-G3	ERLH_13C340	.IES	ERLH_13C330	.IES
	D3					B2-U0-G3	B2-U0-G3	ERLH_13D340	.IES	ERLH_13D330	.IES
	E3					B3-U0-G3	B3-U0-G3	ERLH_13E340	.IES	ERLH_13E330	.IES
14	A3	14000	13400	122	122	B3-U0-G3	B3-U0-G3	ERLH_14A340	.IES	ERLH_14A330	.IES
	B3					B2-U0-G3	B2-U0-G3	ERLH_14B340	.IES	ERLH_14B330	.IES
	C3					B2-U0-G3	B2-U0-G3	ERLH_14C340	.IES	ERLH_14C330	.IES
	D3					B2-U0-G3	B2-U0-G3	ERLH_14D340	.IES	ERLH_14D330	.IES
	E3					B3-U0-G3	B3-U0-G3	ERLH_14E340	.IES	ERLH_14E330	.IES
15	A3	15000	14400	136	136	B3-U0-G3	B3-U0-G3	ERLH_15A340	.IES	ERLH_15A330	.IES
	B3					B2-U0-G3	B2-U0-G3	ERLH_15B340	.IES	ERLH_15B330	.IES
	C3					B2-U0-G3	B2-U0-G3	ERLH_15C340	.IES	ERLH_15C330	.IES
	D3					B2-U0-G3	B2-U0-G3	ERLH_15D340	.IES	ERLH_15D330	.IES
	E3					B3-U0-G3	B3-U0-G3	ERLH_15E340	.IES	ERLH_15E330	.IES
16	A3	16000	15300	149	149	B3-U0-G3	B3-U0-G3	ERLH_16A340	.IES	ERLH_16A330	.IES
	B3					B3-U0-G3	B3-U0-G3	ERLH_16B340	.IES	ERLH_16B330	.IES
	C3					B2-U0-G3	B2-U0-G3	ERLH_16C340	.IES	ERLH_16C330	.IES
	D3					B2-U0-G3	B2-U0-G3	ERLH_16D340	.IES	ERLH_16D330	.IES
	E3					B3-U0-G3	B3-U0-G3	ERLH_16E340	.IES	ERLH_16E330	.IES

Photometrics:

Evolve™ LED Streetlight (ERLH)

ERLH

Type II Narrow
(13A340)

13,000 Lumens
4000K
ERLH_13A340__IES

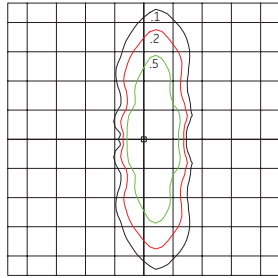

Grid Distance in Units of Mounting Height at 30'
Initial Footcandle Values at Grade

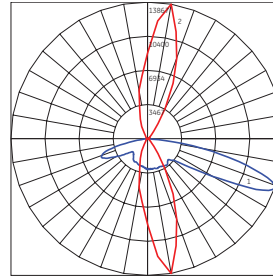

— Vertical plane through horizontal angle of Max. Cd at 80°
— Horizontal cone through vertical angle of Max. Cd at 69°

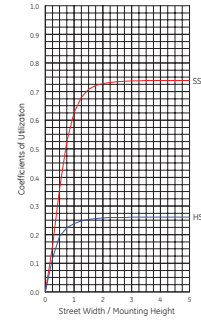

ERLH

Type II Wide
(13B340)

13,000 Lumens
4000K
ERLH_13B340__IES

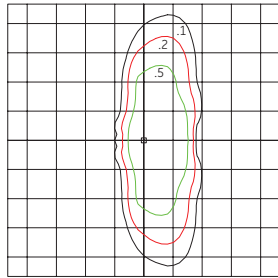

Grid Distance in Units of Mounting Height at 30'
Initial Footcandle Values at Grade

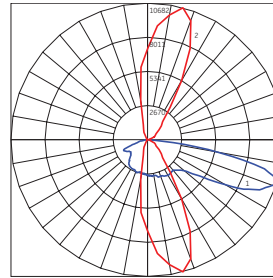

— Vertical plane through horizontal angle of Max. Cd at 75°
— Horizontal cone through vertical angle of Max. Cd at 72°

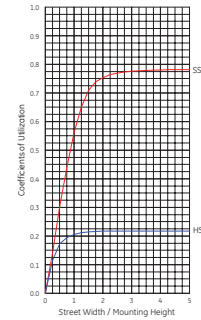

ERLH

Type III
(13C340)

13,000 Lumens
4000K
ERLH_13C340__IES

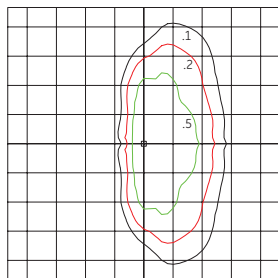

Grid Distance in Units of Mounting Height at 30'
Initial Footcandle Values at Grade

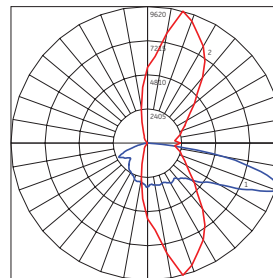

— Vertical plane through horizontal angle of Max. Cd at 75°
— Horizontal cone through vertical angle of Max. Cd at 71°

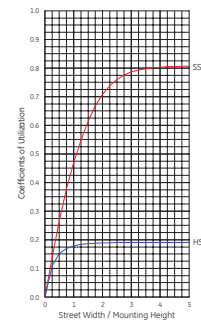

ERLH

Type IV
13D340

13,000 Lumens
4000K
ERLH_13D340__IES

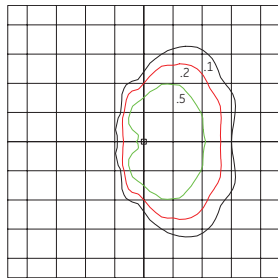

Grid Distance in Units of Mounting Height at 30'
Initial Footcandle Values at Grade

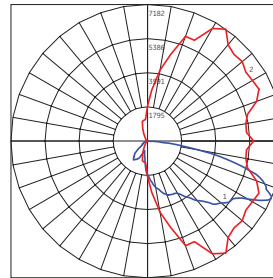

— Vertical plane through horizontal angle of Max. Cd at 55°
— Horizontal cone through vertical angle of Max. Cd at 65°

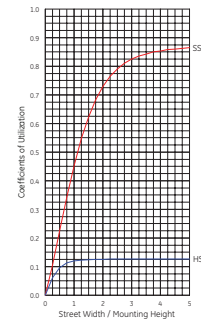

ERLH

Type II Enhanced Back Light
13E340

13,000 Lumens
4000K
ERLH_13E340__IES

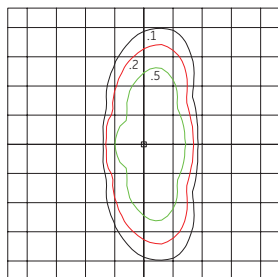

Grid Distance in Units of Mounting Height at 30'
Initial Footcandle Values at Grade

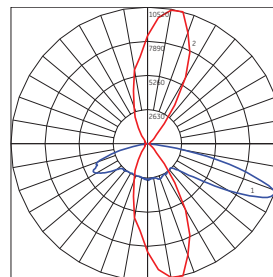

— Vertical plane through horizontal angle of Max. Cd at 75°
— Horizontal cone through vertical angle of Max. Cd at 69°

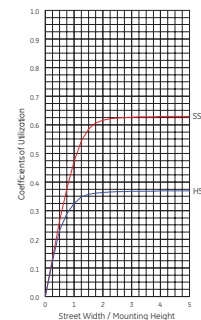

GE Evolve™

LED Roadway Lighting

ERL1-ERLH-ERL2



Project name _____
Date _____
Type _____

ERL 2

PROD. ID	VOLTAGE	LUMEN OUTPUT	DISTRIBUTION*	CCT	CONTROLS	COLOR	OPTIONS
E = Evolve R = Roadway L = Local 2 = Double Module	0 = 120-277V* 1 = 120 2 = 208 3 = 240 4 = 277 5 = 480 D = 347 H = 347-480*	16 18 19 21 23 25 27 28 30	A3 = Type II Narrow B3 = Type II Wide C3 = Type III D3 = Type IV E3 = Type II Enhanced Back Light See Table	30 = 3000K <> 40 = 4000K <> Select 3000K CCT for IDA approved units.	A = ANSI C136.41 7-pin D = ANSI C136.41 7-pin with Shorting Cap E = ANSI C136.41 7-pin with non-Dimming PE Control.* *PE Control Only available for 120-277V or 480V Discrete. Not available for 347-480V or 347V Discrete. NOTE: Dimming controls wired for 0-10V standard unless DALI option "U" requested.	GRAY = Gray BLCK = Black DKBZ = Dark Bronze	A = 4 Bolt Slipfitter † F = Fusing G = Internal Bubble Level I = IP66 Optical L = Tool-Less Entry R = Secondary 10kV/5kA SPD U = DALI Programmable ^ Y = Coastal Finish * XXX = Special Options † Contact manufacturer for Lead-Time. * Recommended for installations within 750 ft. from the coast. Contact Factory for Lead-Time. + Compatible with LightGrid 2.0 nodes. ^ Not available in 347V, 480V or 347-480V.
		* Not available with Fusing. Must choose a discrete voltage with F option.		*Nominal IES Type classing subject to typical variation, individual units may differ.			

LUMEN OUTPUT	DISTRIBUTION	TYPICAL INITIAL LUMENS		TYPICAL SYSTEM WATTAGE		BUG RATING		IES FILE NUMBER							
		4000K	3000K	120-277V	347-480V	4000K	3000K	4000K		3000K					
								120-277V	347-480V	120-277V	347-480V				
16	A3	16000	15300	120	120	B3-U0-G3	B3-U0-G3	ERL2_16A340	.IES			ERL2_16A330	.IES		
	B3					B3-U0-G3	ERL2_16B340	.IES			ERL2_16B330	.IES			
	C3					B2-U0-G3	ERL2_16C340	.IES			ERL2_16C330	.IES			
	D3					B2-U0-G3	ERL2_16D340	.IES			ERL2_16D330	.IES			
	E3					B3-U0-G3	ERL2_16E340	.IES			ERL2_16E330	.IES			
18	A3	18000	17300	140	140	B3-U0-G3	B3-U0-G3	ERL2_18A340	.IES			ERL2_18A330	.IES		
	B3					B3-U0-G3	ERL2_18B340	.IES			ERL2_18B330	.IES			
	C3					B2-U0-G3	ERL2_18C340	.IES			ERL2_18C330	.IES			
	D3					B2-U0-G3	ERL2_18D340	.IES			ERL2_18D330	.IES			
	E3					B3-U0-G3	ERL2_18E340	.IES			ERL2_18E330	.IES			
19	A3	19000	18200	149	149	B3-U0-G3	B3-U0-G3	ERL2_19A340	.IES			ERL2_19A330	.IES		
	B3					B3-U0-G3	ERL2_19B340	.IES			ERL2_19B330	.IES			
	C3					B2-U0-G3	ERL2_19C340	.IES			ERL2_19C330	.IES			
	D3					B2-U0-G3	ERL2_19D340	.IES			ERL2_19D330	.IES			
	E3					B3-U0-G3	ERL2_19E340	.IES			ERL2_19E330	.IES			
21	A3	21000	20100	174	177	B3-U0-G3	B3-U0-G3	ERL2_21A340	-120-277V/IES	ERL2_21A340	-347-480V/IES	ERL2_21A330	-120-277V/IES	ERL2_21A330	-347-480V/IES
	B3					B3-U0-G3	ERL2_21B340	-120-277V/IES	ERL2_21B340	-347-480V/IES	ERL2_21B330	-120-277V/IES	ERL2_21B330	-347-480V/IES	
	C3					B3-U0-G3	ERL2_21C340	-120-277V/IES	ERL2_21C340	-347-480V/IES	ERL2_21C330	-120-277V/IES	ERL2_21C330	-347-480V/IES	
	D3					B2-U0-G3	ERL2_21D340	-120-277V/IES	ERL2_21D340	-347-480V/IES	ERL2_21D330	-120-277V/IES	ERL2_21D330	-347-480V/IES	
	E3					B3-U0-G3	ERL2_21E340	-120-277V/IES	ERL2_21E340	-347-480V/IES	ERL2_21E330	-120-277V/IES	ERL2_21E330	-347-480V/IES	
23	A3	23000	22100	194	196	B3-U0-G3	B3-U0-G3	ERL2_23A340	-120-277V/IES	ERL2_23A340	-347-480V/IES	ERL2_23A330	-120-277V/IES	ERL2_23A330	-347-480V/IES
	B3					B3-U0-G3	ERL2_23B340	-120-277V/IES	ERL2_23B340	-347-480V/IES	ERL2_23B330	-120-277V/IES	ERL2_23B330	-347-480V/IES	
	C3					B3-U0-G4	ERL2_23C340	-120-277V/IES	ERL2_23C340	-347-480V/IES	ERL2_23C330	-120-277V/IES	ERL2_23C330	-347-480V/IES	
	D3					B2-U0-G4	ERL2_23D340	-120-277V/IES	ERL2_23D340	-347-480V/IES	ERL2_23D330	-120-277V/IES	ERL2_23D330	-347-480V/IES	
	E3					B4-U0-G4	ERL2_23E340	-120-277V/IES	ERL2_23E340	-347-480V/IES	ERL2_23E330	-120-277V/IES	ERL2_23E330	-347-480V/IES	
25	A3	25000	24000	214	214	B3-U0-G3	B3-U0-G3	ERL2_25A340	.IES			ERL2_25A330	.IES		
	B3					B3-U0-G3	ERL2_25B340	.IES			ERL2_25B330	.IES			
	C3					B3-U0-G4	ERL2_25C340	.IES			ERL2_25C330	.IES			
	D3					B2-U0-G4	ERL2_25D340	.IES			ERL2_25D330	.IES			
	E3					B4-U0-G4	ERL2_25E340	.IES			ERL2_25E330	.IES			
27	A3	27000	25900	237	237	B3-U0-G3	B3-U0-G3	ERL2_27A340	.IES			ERL2_27A330	.IES		
	B3					B3-U0-G4	ERL2_27B340	.IES			ERL2_27B330	.IES			
	C3					B3-U0-G4	ERL2_27C340	.IES			ERL2_27C330	.IES			
	D3					B2-U0-G4	ERL2_27D340	.IES			ERL2_27D330	.IES			
	E3					B4-U0-G4	ERL2_27E340	.IES			ERL2_27E330	.IES			
28	A3	28000	26900	251	251	B3-U0-G3	B3-U0-G3	ERL2_28A340	.IES			ERL2_28A330	.IES		
	B3					B3-U0-G4	ERL2_28B340	.IES			ERL2_28B330	.IES			
	C3					B3-U0-G4	ERL2_28C340	.IES			ERL2_28C330	.IES			
	D3					B2-U0-G4	ERL2_28D340	.IES			ERL2_28D330	.IES			
	E3					B4-U0-G4	ERL2_28E340	.IES			ERL2_28E330	.IES			
30	A3	30000	28800	278	278	B4-U0-G4	B4-U0-G4	ERL2_30A340	.IES			ERL2_30A330	.IES		
	B3					B3-U0-G4	ERL2_30B340	.IES			ERL2_30B330	.IES			
	C3					B3-U0-G4	ERL2_30C340	.IES			ERL2_30C330	.IES			
	D3					B2-U0-G4	ERL2_30D340	.IES			ERL2_30D330	.IES			
	E3					B4-U0-G4	ERL2_30E340	.IES			ERL2_30E330	.IES			

Photometrics:

Evolve™ LED Streetlight (ERL2)

ERL2

Type II Narrow
 (23A340)

23,000 Lumens
 4000K
 ERL2_23A340___.IES

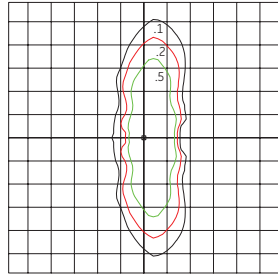

Grid Distance in Units of Mounting Height at 30'
 Initial Footcandle Values at Grade

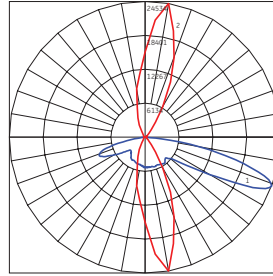

— Vertical plane through horizontal angle of Max. Cd at 80°
 — Horizontal cone through vertical angle of Max. Cd at 69°

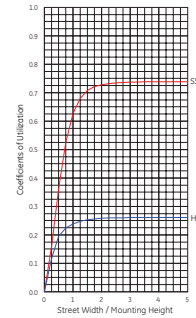

ERL2

Type II Wide
 (23B340)

23,000 Lumens
 4000K
 ERL2_23B340___.IES

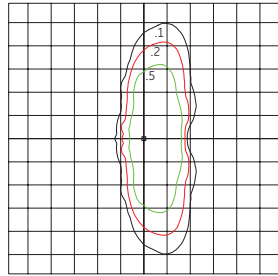

Grid Distance in Units of Mounting Height at 30'
 Initial Footcandle Values at Grade

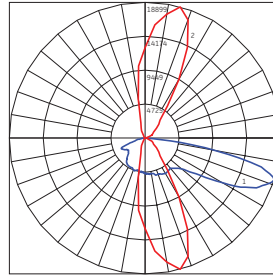

— Vertical plane through horizontal angle of Max. Cd at 75°
 — Horizontal cone through vertical angle of Max. Cd at 72°

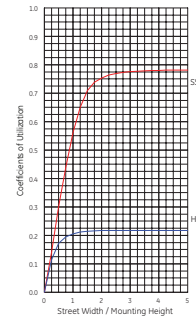

ERL2

Type III
 (23C340)

23,000 Lumens
 4000K
 ERL2_23C340___.IES

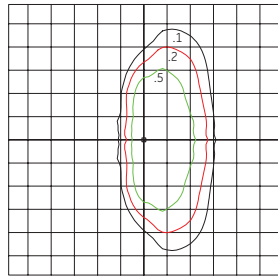

Grid Distance in Units of Mounting Height at 30'
 Initial Footcandle Values at Grade

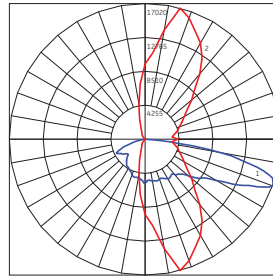

— Vertical plane through horizontal angle of Max. Cd at 75°
 — Horizontal cone through vertical angle of Max. Cd at 71°

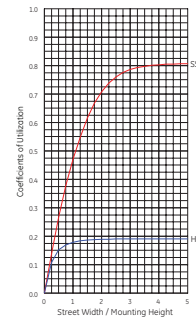

ERL2

Type IV
 (23D340)

23,000 Lumens
 4000K
 ERL2_23D340___.IES

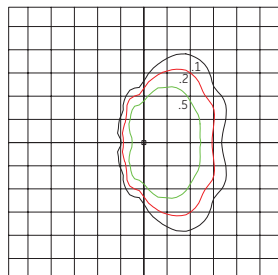

Grid Distance in Units of Mounting Height at 30'
 Initial Footcandle Values at Grade

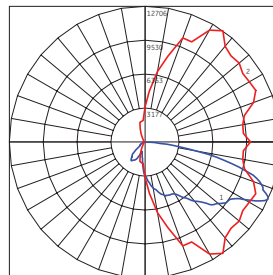

— Vertical plane through horizontal angle of Max. Cd at 55°
 — Horizontal cone through vertical angle of Max. Cd at 65°

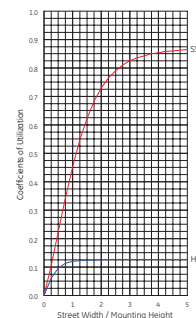

ERL2

Type II Enhanced Back Light
 (23E340)

23,000 Lumens
 4000K
 ERL2_23E340___.IES

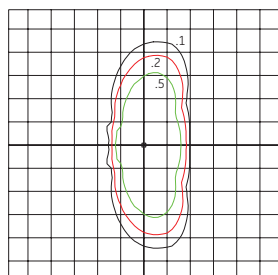

Grid Distance in Units of Mounting Height at 30'
 Initial Footcandle Values at Grade

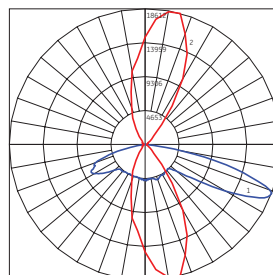

— Vertical plane through horizontal angle of Max. Cd at 75°
 — Horizontal cone through vertical angle of Max. Cd at 69°

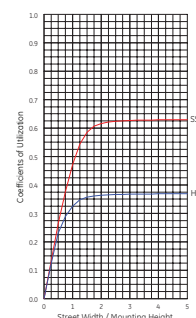

GE Evolve™
 LED Roadway Lighting
 ERL1-ERLH-ERL2

Product Dimensions:
 Evolve™ LED Streetlight (ERL1)

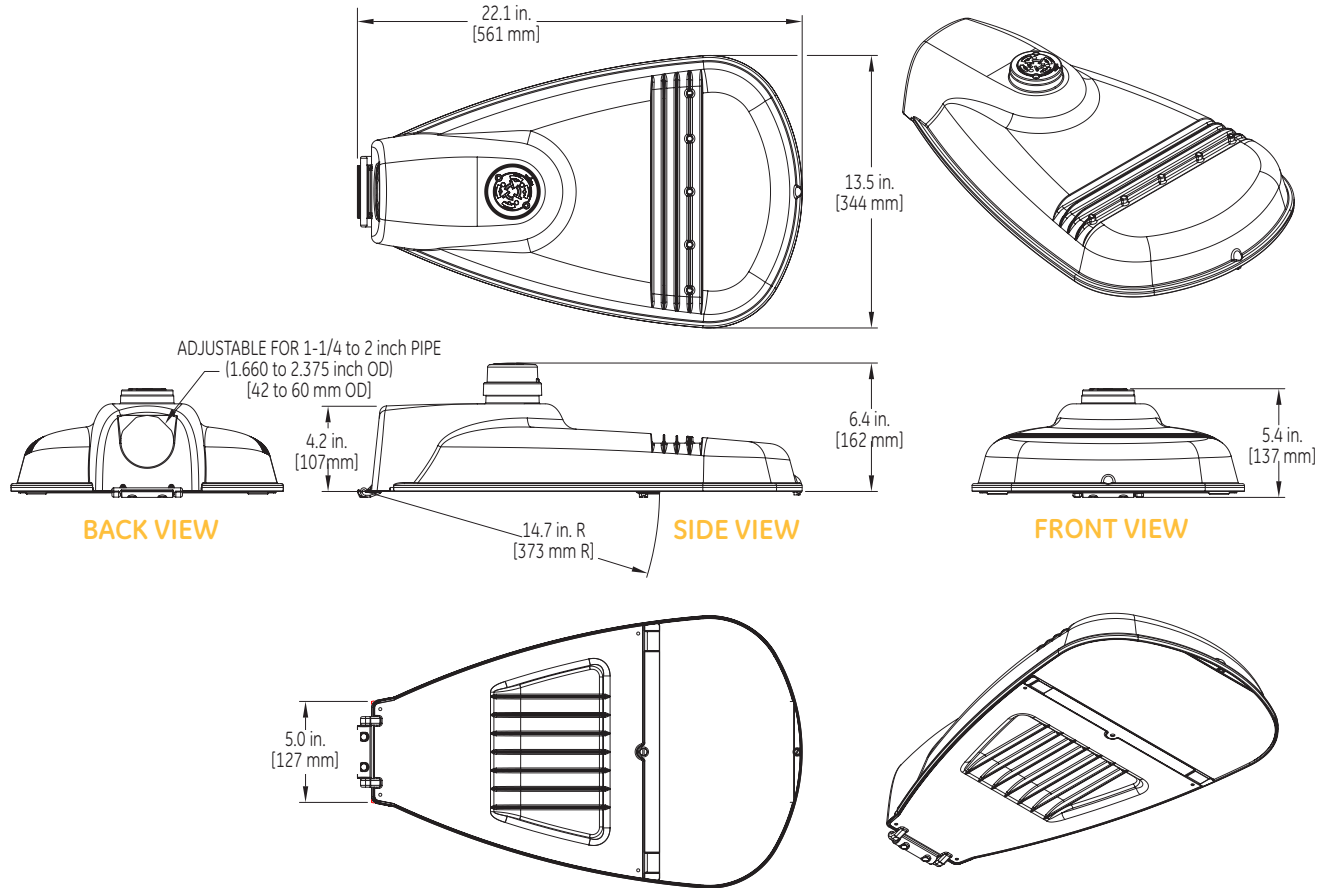

DATA

- Approximate net weight: 12.4 lbs (5.6kgs) -15.5 lbs (7.0kgs) with XFMR
- Effective Projected Area (EPA): 0.5 sq ft max (0.046 sq m)

GE Evolve™
 LED Roadway Lighting
 ERL1-ERLH-ERL2

Product Dimensions:
 Evolve™ LED Streetlight (ERLH)

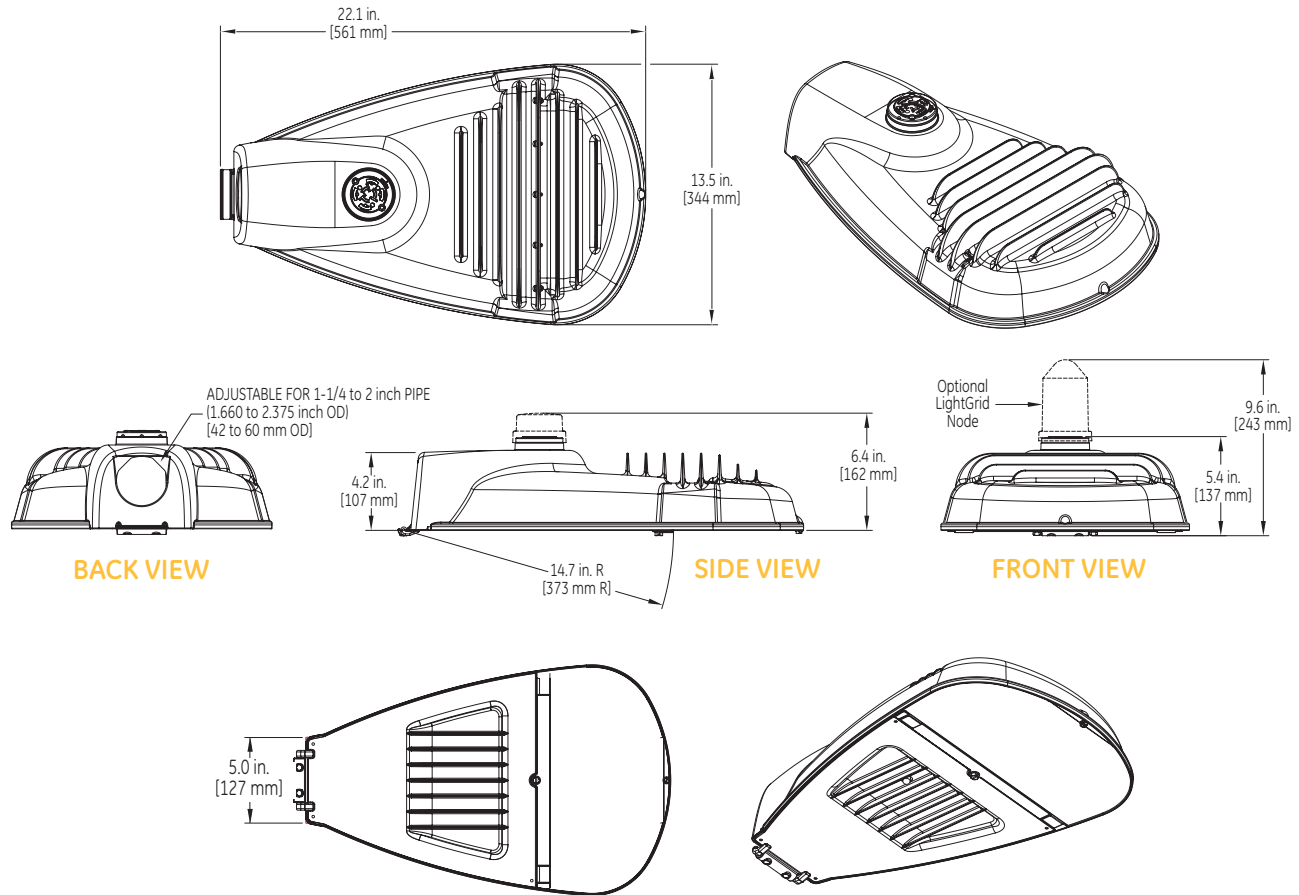

DATA	
	• Approximate net weight: 15.15 lbs (6.9 kgs) - 2 Bolt Slipfitter
	• Approximate net weight: 15.85 lbs (7.2 kgs) - 4 Bolt Slipfitter
	• Effective Projected Area (EPA): 0.5 sq ft max (0.046 sq m)

GE Evolve™
 LED Roadway Lighting
 ERL1-ERLH-ERL2

Product Dimensions:
 Evolve™ LED Streetlight (ERL2)

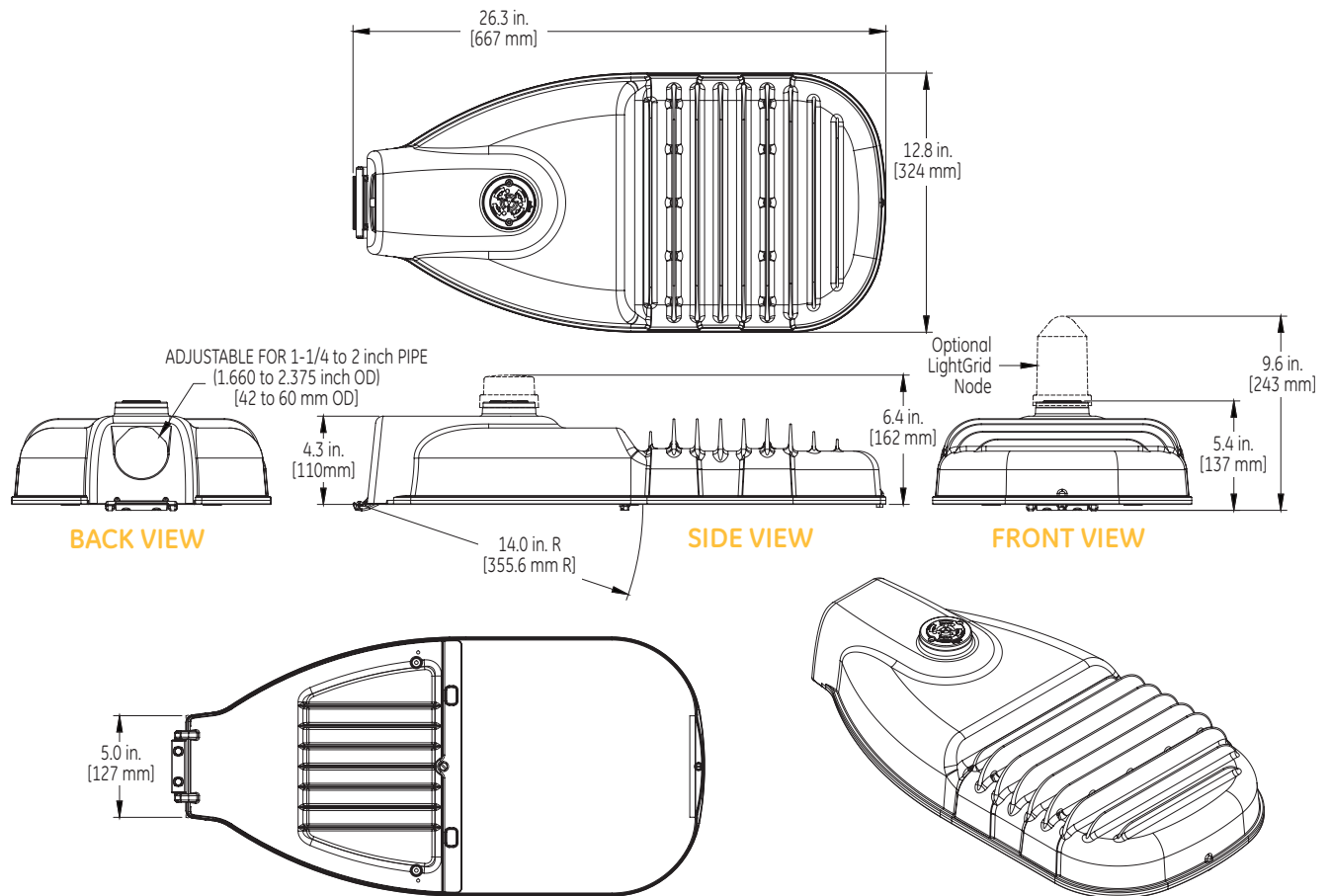

DATA	
	<ul style="list-style-type: none"> • Approximate net weight: 24.0 lbs (10.9 kgs) Contact manufacturer for specific configuration weight. • Effective Projected Area (EPA): 0.57 sq ft max (0.053 sq m)

Evolve™ LED Flood Lighting

EFH1



current
powered by GE



Product Features

The GE Evolve™ LED High Output Flood Light is our brightest solution to efficiently illuminate building façade, flag poles, billboard signage and many more traditional flood applications. Designed to replace 250W-400W HPS and 400W-1000W Metal Halide flood lights, the EFH1 provides significant operating cost benefits over the life of each fixture with reduced energy consumption and a long rated life that virtually eliminates ongoing maintenance expenses.

Applications

- Site, area, and general lighting applications utilizing advanced LED reflective optical system.



Housing

- Die-cast aluminum housing.
- Slim architectural design incorporates an integral heat sink and light engine, ensuring maximum heat transfer, long LED life.
- Meets 2G vibration with knuckle mount and 3G with trunnion mount.

Optical System

- Evolve™ light engine consisting of reflective technology designed to optimize application efficiency and minimize glare.
- LM-79 tests and reports are performed in accordance with IESNA standards.
- 70 CRI at 3000K, 4000K and 5000K typical
- NEMA Distributions: 6x5, 6x6, 7x6 and 7x7.

Ratings

-   listed, suitable for wet locations.
- IP66 optical enclosure per ANSI C136.25-2009
- Temperature Rated at -40°C to +50°C
- Complies with the material restrictions of RoHS.



DLC Premium qualified models available. Please refer to <http://www.designlights.org/QPL> for complete information.

Lumen Maintenance

Ambient Temp.	Optical Code	Projected ¹		Calculated ²	
		25K Hour	50K Hour	88K Hour	100K Hour
5°C (41°F)	AA, BB, CC, DD, EE	0.964	0.945	0.918	0.910
10°C (50°F)		0.961	0.940	0.909	0.900
15°C (59°F)		0.958	0.934	0.899	0.888
20°C (68°F)		0.954	0.927	0.887	0.875
25°C (77°F)		0.950	0.920	0.875	0.861
35°C (95°F)		0.926	0.885	0.827	0.809
40°C (104°F)		0.914	0.863	0.790	0.768

Note: Based on 10,000 hours LM-80 data. For details, see http://www.energystar.gov/ia/partners/prod_development/new_specs/downloads/luminaires/ENERGY_STAR_Final_Lumen_Maintenance_Guidance.pdf.

¹ In accordance with IESNA TM-21-11, Projected Values represent interpolated values based on time durations that are within six times (6X) the IESNA LM-80-08 total test duration (in hours) for the device under testing (IDUT) i.e. the packaged LED chip).

² In accordance with IESNA TM-21-11, Calculated Values represent time durations that exceed six times (6X) the IESNA LM-80-08 total test duration (in hours) for the device under testing (IDUT) i.e. the packaged LED chip).

Mounting

Option K

- K1 = Knuckle Slipfitter for 1.9 in. - 2.3 in. OD Tenon, with wires exiting tenon.
- K2 = Knuckle Slipfitter for 1.9 in. - 2.3 in. OD Tenon, external 3ft #14/3 power cable.

Option S

- S1 = Knuckle Slipfitter for 1.9 in. - 3.0 in. (48-76mm) OD Tenon.
- S2 = Knuckle Slipfitter for 1.9 in. - 3.0 in. (48-76mm) OD Tenon, with external 3ft #14/3 power cable.

Option V

- V1 = Knuckle Wall Mount. Lead wires exiting tenon.

Option T

- T1 = Trunnion, with external 3ft #14/3 power cable.

Finish

- Corrosion resistant polyester powder painted, minimum 2.0 mil. thickness.
- Standard colors: Dark Bronze, Black, White and Gray.
- RAL & custom colors available.

Electrical

- 120-277 VAC and 347-480 VAC available.
- System power factor is >90% and THD <20%.
- ANSI C136.41 PE Socket Standard. Light Grid compatible.
- Dimming:
 - 0-10V continuous dimming standard.
 - DALI digital dimming available. Contact manufacturer.
- DALI compatible drivers available in 120-277 VAC.
- Surge Protection; per ANSI C136.2-2015.
 - - 6kV/3kA "Basic" surge protection, standard.
 - - 10kV/5kA "Enhanced" surge protection, optional.
- EMI: Title 47 CFR Part 15 Class A

Warranty

- 5yr standard warranty

Accessories

- Top & Side Visor
- Wire Guard
- Vandal Shield
- Barn Door Assembly

Ordering Number Logic

Evolve™ LED High Output Flood Light (EFH1)



EFH1 01 _____ 7 _____

PROD. ID	GENERATION	VOLTAGE	OPTICAL CODE	DISTRIBUTION	CRI	CCT	DIMMING	CONTROLS	MOUNTING	FINISH	OPTIONS
E = Evolve FH = Flood H-Series 1 = Standard	01 = 1st Generation	0 = 120-277* 1 = 120 2 = 208 3 = 240 4 = 277 5 = 480 D = 347 H = 347-480* * Not available with Fusing. Must choose a discrete voltage with F Option.	65 = NEMA 6x5 66 = NEMA 6x6 76 = NEMA 7x6 77 = NEMA 7x7	7 = 70 (min)	30 = 3000K 40 = 4000K 50 = 5000K	A = ANSI C136.41 7-pin Receptacle++ D = External Dimming 18/2 3ft cable+ N = Non-Dimmable+ P = External Dimming 18/2 3ft cable with 7-pin Receptacle++ + No PE Receptacle (Unrestricted Aiming Angle). ++ All Units with option A and P have restricted Aiming Angle.	A = No Control D = Shorting Cap Contact manufacturer for dimming PE and standard PE control options. Must order separately.	K1 = Knuckle Slipfitter for 1.9 in. - 2.3 in. OD Tenon.* S1 = Knuckle Slipfitter for 1.9 in. - 3.0 in. (48-76mm) OD Tenon. K2 = Knuckle Slipfitter for 1.9 in. - 2.3 in. OD Tenon, with external 3ft #14/3 power cable. S2 = Knuckle Slipfitter for 1.9 in. - 3.0 in. (48-76mm) OD Tenon, with external 3ft #14/3 power cable. V1 = Knuckle Wall Mount* T1 = Trunion, with external 3ft #14/3 power cable. * Lead wires exiting tenon.	GRAY = Gray BLCK = Black DKBZ = Dark Bronze WHITE = White	F = Fusing L = Tool-Less Entry R = Enhanced Surge Protection (10kV/5kA) M = NOM31* U = Universal DALI digital dimming+# V = 3-position Terminal Block XXX = Special Options * Contact manufacturer + Compatible with Light Grid 2.0 nodes. # Not compatible at 347-480V.	



OPTICAL CODE	DISTRIBUTION CODE	NEMA CLASSIFICATION	TYPICAL INITIAL LUMENS			TYPICAL SYSTEM WATTAGE		IES FILE NUMBER				
			3000K	4000K	5000K	120-277V 347-480V	3000K	4000K	5000K			
AA	77	7 X 7	18900	19300	19500	150	EFH101_AA77730	IES	EFH101_AA77740	IES	EFH101_AA77750	IES
BB	77	7 X 7	26300	26800	27100	194	EFH101_BB77730	IES	EFH101_BB77740	IES	EFH101_BB77750	IES
CC	77	7 X 7	29100	29700	30000	218	EFH101_CC77730	IES	EFH101_CC77740	IES	EFH101_CC77750	IES
DD	77	7 X 7	34000	34700	35000	266	EFH101_DD77730	IES	EFH101_DD77740	IES	EFH101_DD77750	IES
EE	77	7 X 7	37900	38700	39000	297	EFH101_EE77730	IES	EFH101_EE77740	IES	EFH101_EE77750	IES
AA	76	7 X 6	18500	18800	19000	150	EFH101_AA76730	IES	EFH101_AA76740	IES	EFH101_AA76750	IES
BB	76	7 X 6	25700	26200	26500	194	EFH101_BB76730	IES	EFH101_BB76740	IES	EFH101_BB76750	IES
CC	76	7 X 6	28400	29000	29300	218	EFH101_CC76730	IES	EFH101_CC76740	IES	EFH101_CC76750	IES
DD	76	7 X 6	33200	33900	34200	266	EFH101_DD76730	IES	EFH101_DD76740	IES	EFH101_DD76750	IES
EE	76	7 X 6	37100	37800	38100	297	EFH101_EE76730	IES	EFH101_EE76740	IES	EFH101_EE76750	IES
AA	66	6 X 6	18200	18600	18800	150	EFH101_AA66730	IES	EFH101_AA66740	IES	EFH101_AA66750	IES
BB	66	6 X 6	25400	25900	26200	194	EFH101_BB66730	IES	EFH101_BB66740	IES	EFH101_BB66750	IES
CC	66	6 X 6	28100	28700	29000	218	EFH101_CC66730	IES	EFH101_CC66740	IES	EFH101_CC66750	IES
DD	66	6 X 6	32800	33500	33800	266	EFH101_DD66730	IES	EFH101_DD66740	IES	EFH101_DD66750	IES
EE	66	6 X 6	36600	37400	37700	297	EFH101_EE66730	IES	EFH101_EE66740	IES	EFH101_EE66750	IES
AA	65	6 X 5	17300	17700	17900	150	EFH101_AA65730	IES	EFH101_AA65740	IES	EFH101_AA65750	IES
BB	65	6 X 5	24100	24600	24800	194	EFH101_BB65730	IES	EFH101_BB65740	IES	EFH101_BB65750	IES
CC	65	6 X 5	26700	27200	27500	218	EFH101_CC65730	IES	EFH101_CC65740	IES	EFH101_CC65750	IES
DD	65	6 X 5	31200	31800	32100	266	EFH101_DD65730	IES	EFH101_DD65740	IES	EFH101_DD65750	IES
EE	65	6 X 5	34800	35500	35800	297	EFH101_EE65730	IES	EFH101_EE65740	IES	EFH101_EE65750	IES

PE Accessories (to be ordered separately)

SAP Number	Part Number	Description
93029237	PED-MV-LED-7	ANSI C136.41 Dimming PE, 120-277V
93029238	PED-347-LED-7	ANSI C136.41 Dimming PE, 347V
93029239	PED-480-LED-7	ANSI C136.41 Dimming PE, 480V

SAP Number	Part Number	Description
28299	PECOTL	STANDARD 120-277V
28294	PECSTL	STANDARD 480V
80436	PECCTL	STANDARD 347V
73251	SCCL-PECTL	Shorting cap

Photometrics

Evolve™ LED High Output Flood Light (EFH1)

77-EE

38,700 Lumens, 4000K (EFH101_EE77740_.ies)

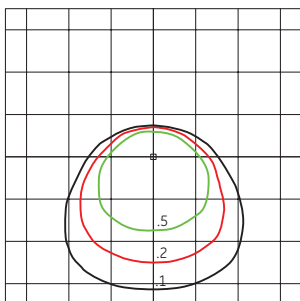

Grid Distance in Units of Mounting Height at 35° and 45° Tilt Initial Footcandle Values at Grade

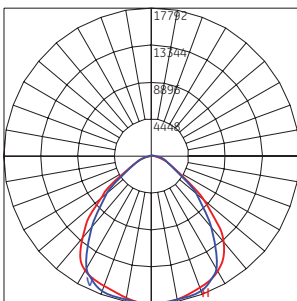

— Vertical Axel Candela Distribution
— Horizontal Axel Candela Distribution

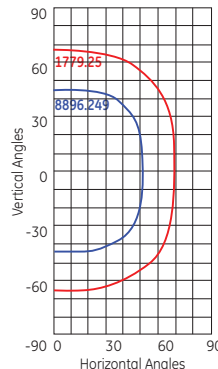

Isocandela Display	
10% Max	1779.25 (1779.2499 Cd)
50% Max	8896.249 (8896.2495 Cd)

76-EE

37,800 Lumens, 4000K (EFH101_EE76740_.ies)

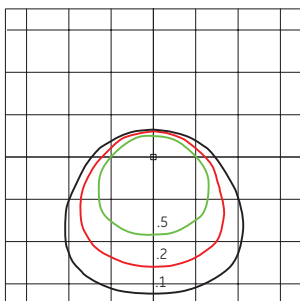

Grid Distance in Units of Mounting Height at 35° and 45° Tilt Initial Footcandle Values at Grade

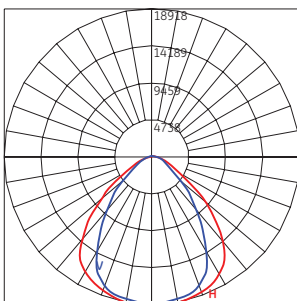

— Vertical Axel Candela Distribution
— Horizontal Axel Candela Distribution

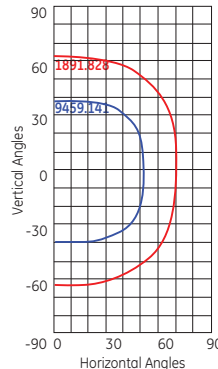

Isocandela Display	
10% Max	1891.828 (1891.8282 Cd)
50% Max	9459.141 (9459.141 Cd)

66-EE

37,400 Lumens, 4000K (EFH101_EE66740_.ies)

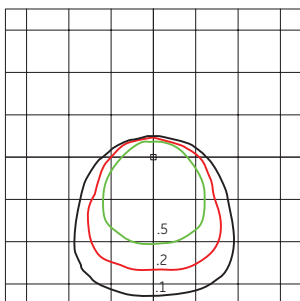

Grid Distance in Units of Mounting Height at 35° and 45° Tilt Initial Footcandle Values at Grade

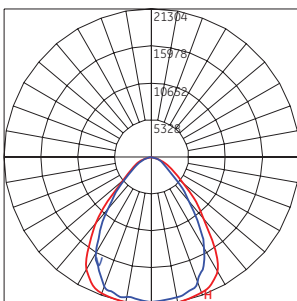

— Vertical Axel Candela Distribution
— Horizontal Axel Candela Distribution

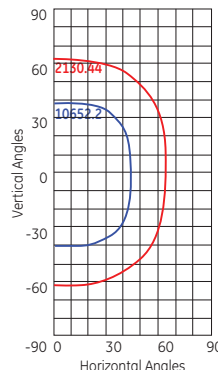

Isocandela Display	
10% Max	2130.44 (2130.4402 Cd)
50% Max	10652.201 (10652.201 Cd)

65-EE

35,500 Lumens, 4000K (EFH101_EE65740_.ies)

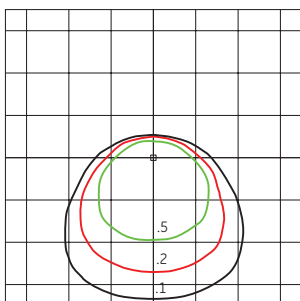

Grid Distance in Units of Mounting Height at 35° and 45° Tilt Initial Footcandle Values at Grade

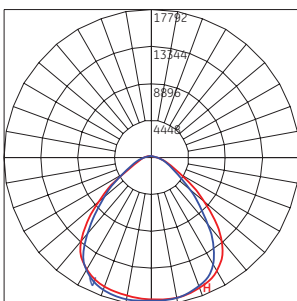

— Vertical Axel Candela Distribution
— Horizontal Axel Candela Distribution

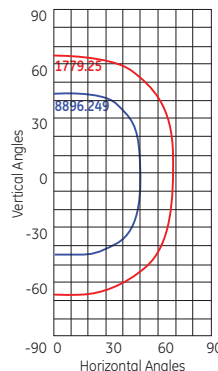

Isocandela Display	
10% Max	1779.25 (1779.2499 Cd)
50% Max	8896.249 (8896.2495 Cd)

Product Dimensions

Evolve™ LED High Output Flood Light (EFH1)

Trunnion Mounting

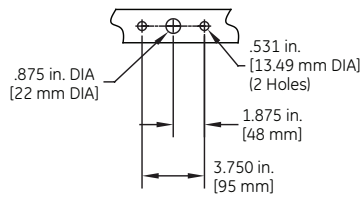
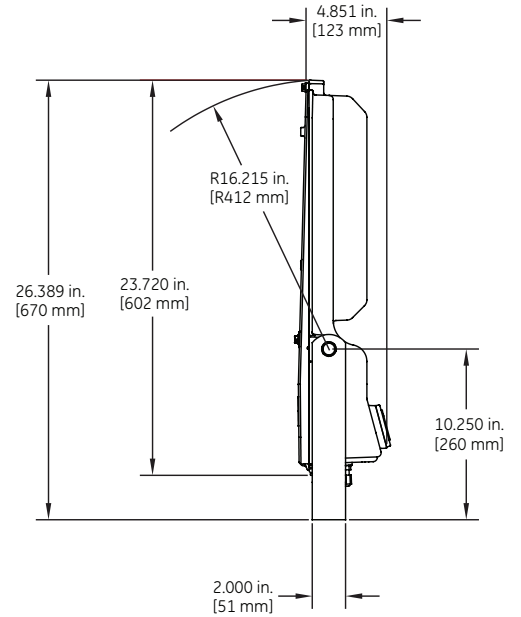
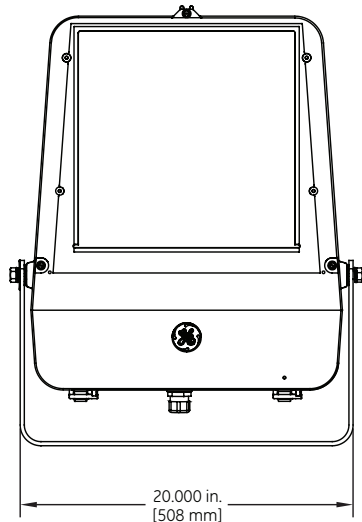
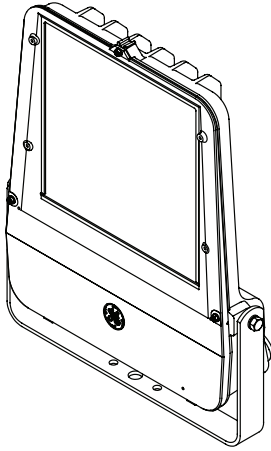

Slipfitter Mounting

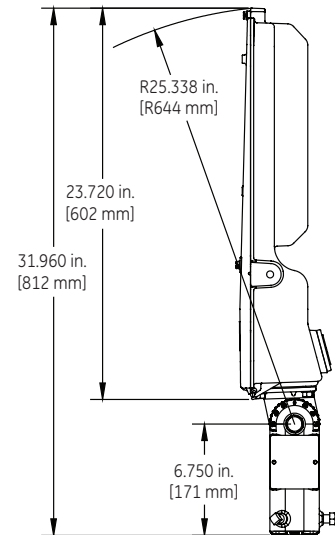
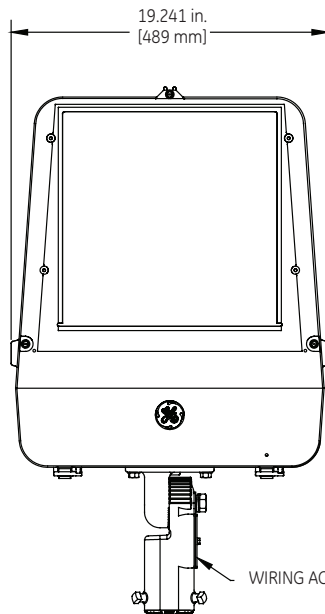
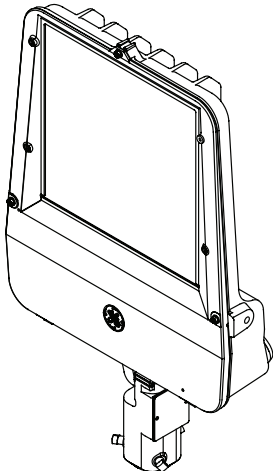

Product Dimensions

Evolve™ LED High Output Flood Light (EFH1)

Wall Mounting

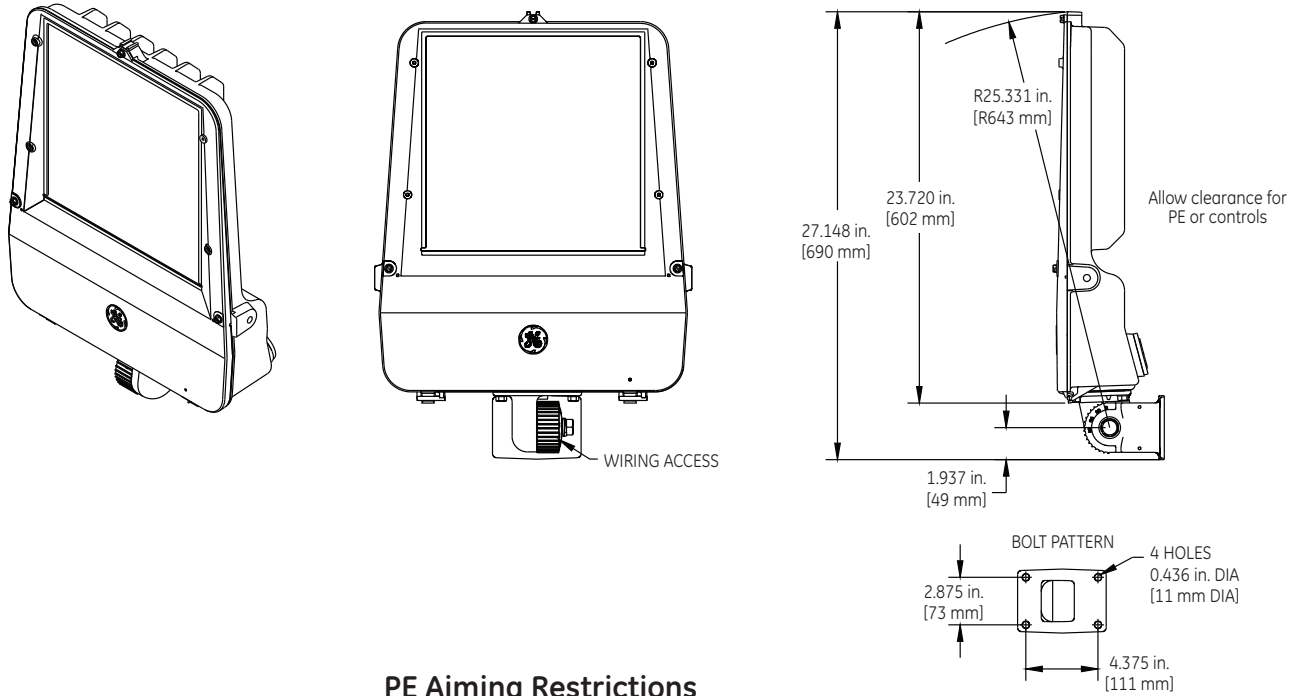

PE Aiming Restrictions

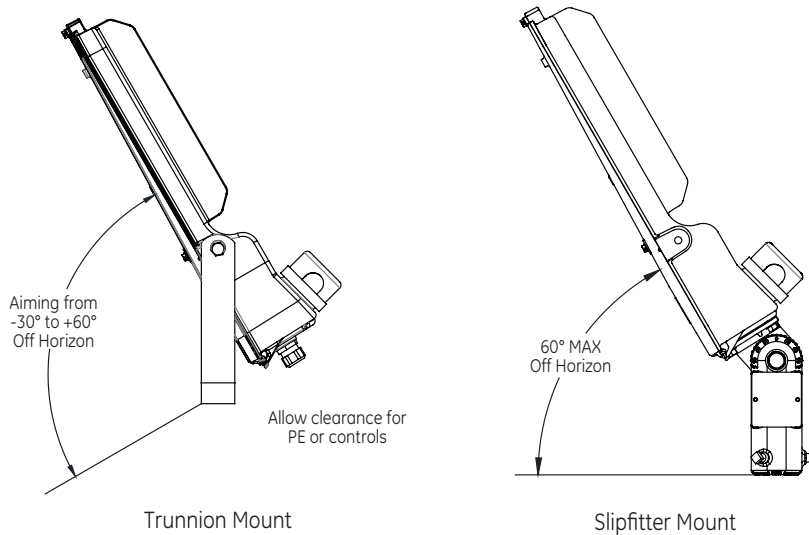

DATA

- Approximate net weight: 35 lbs (15.9 kgs)
- Effective Projected Area:
 - Vertical 3.51 sq ft (0.33 sq M) (aimed at horizon)
 - Tilted 1.79 sqft (0.17 sq M) (aimed down 45 degrees)

Accessories

Evolve™ LED High Output Flood Light (EFH1)

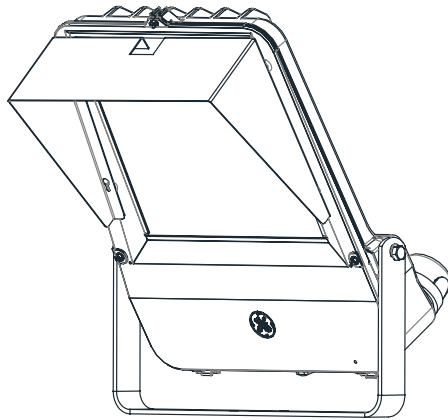

Top And Side Visor

Ordering Logic: TSVGRAY-EFH
TSVBLCK-EFH
TSVDKBZ-EFH
TSVWHITE-EFH

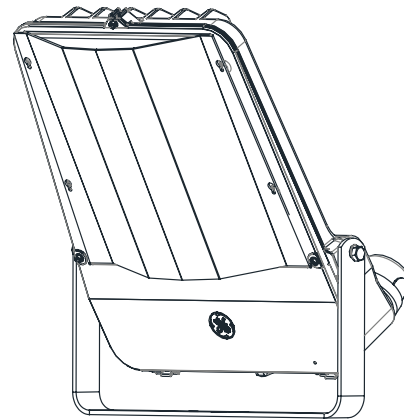

Vandal Shield

Ordering Logic: VAN-EFH

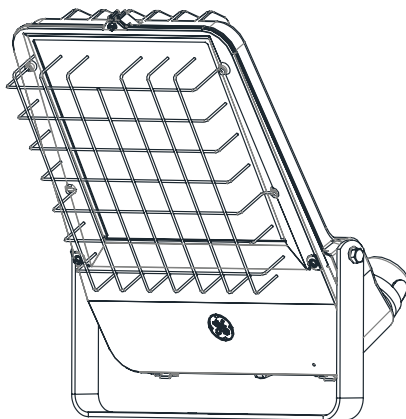

Wire Guard

Ordering Logic: WG-EFH

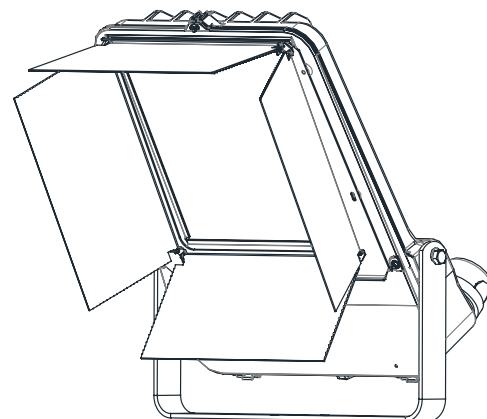

Barn Doors

Ordering Logic: BDAGRAY-EFH
BDABLCK-EFH
BDADKBZ-EFH
BDAWHITE-EFH



www.currentbyge.com

All trademarks are the property of their respective owners. Information provided is subject to change without notice. All values are design or typical values when measured under laboratory conditions. Current, powered by GE is a business of the General Electric Company.
© 2017 GE.

OLP3107 (Rev 02/20/17)

Streetworks

DESCRIPTION

The Traditionaire AF series LED outdoor luminaire displays the old-fashioned charm of traditional area lighting, enhancing any setting with distinctive styling. As a decorative luminaire, the Traditionaire LED tastefully complements the architectural and environmental design of parks and roadways. The high-lumen downlight configuration uses Eaton's patented AccuLED Optics™ technology to deliver uniform and efficient illumination to pedestrian and roadway applications.

Catalog #		Type
Project		
Comments		Date
Prepared by		

SPECIFICATION FEATURES

Construction

Hinged (stainless steel hinge pins) die-cast aluminum housing and cover with cupola. 3G vibration tested to ensure strength of construction and longevity in application.

Optics

Choice of three patented, high-efficiency AccuLED Optic™ technology manufactured from injection-molded acrylic. Optics are precisely designed to shape the light output, maximizing efficiency and application spacing. AccuLED Optic technology, creates consistent distributions with the scalability to meet customized application requirements. Offered Standard in 4000K (+/- 275K) CCT and minimum 70 CRI. Optional 3000K CCT. For the ultimate level of spill light control, an optional

house-side shield accessory can be field or factory installed. Optics are IP66 enclosure rated.

Electrical

LED drivers mount to die-cast aluminum back housing for optimal heat sinking, operation efficacy, and prolonged life. Standard drivers feature electronic universal voltage (120-277V 50/60Hz), 347V 60Hz or 480V 60Hz operation, greater than 0.9 power factor, less than 20% harmonic distortion, and is suitable for operation in -40°C to 40°C ambient environments. All fixtures are shipped standard with 10kV/10kA common – and differential – mode surge protection and 10kV MOV as an optional alternate.

Mounting

Self-aligning pole-top fitter for 3" O.D. pole tops or vertical tenons. Square headed 1-1/4" polymer coated mounting bolts with a lock nut.

Finish

Cast components finished in a super durable black TGIC polyester powder coat paint, 2.5 mil nominal thickness for superior protection against fade and wear. Optional colors include: bronze, grey and white. RAL and custom color matches available.

Warranty

Five-year warranty.



UTLD TRADITIONAIRE LED DOWNLIGHT

AF24

Solid State LED

DECORATIVE POST TOP
LUMINAIRE

DIMENSIONS

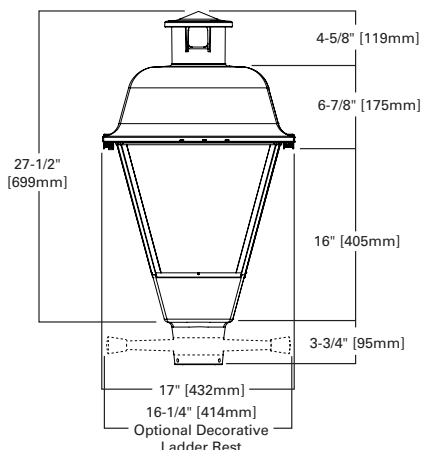

OPTIONAL BIRD CONE

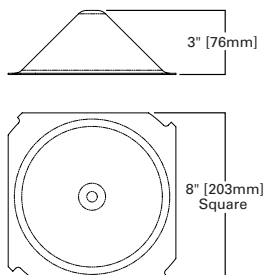

CERTIFICATION DATA

UL and cUL Wet Location Listed
3G Vibration Rated
IP66 Rated
ISO 9001
Dark Sky Approved (3000K CCT and warmer only)

ENERGY DATA

Electronic LED Driver

>0.9 Power Factor
<20% Total Harmonic Distortion
120-277V/50 & 60Hz, 347V/60Hz,
480V/60Hz
-40°C Minimum Temperature
40°C Ambient Temperature Rating

EPA

Effective Projected Area: (Sq. Ft.)
2.3

SHIPPING DATA

Approximate Net Weight:
22.8 lbs. (10.34 kgs.)

POWER AND LUMENS (STANDARD CONFIGURATION - NO LENSES OR BIRD CONE)

Light Engine *	AF24-20	AF24-30	AF24-40	AF24-50	AF24-60	AF24-70	AF24-80	AF24-90	AF24-100	
Nominal Power (Watts)	21	31	40	54	64	74	83	94	96	
Wattage Label	20	30	40	50	60	70	80	90	100	
Current @ 120V (A)	0.18	0.26	0.34	0.45	0.53	0.62	0.70	0.78	0.80	
Current @ 277V (A)	--	0.12	0.15	0.21	0.24	0.28	0.31	0.35	0.35	
Current @ 347V (A)	--	0.10	0.13	0.16	0.19	0.22	0.24	0.28	0.28	
Current @ 480V (A)	--	0.07	0.09	0.13	0.14	0.17	0.18	0.21	0.21	
Optics										
T2U	4000K	2,429	3,400	4,420	5,666	6,587	7,371	8,064	8,722	8,740
	BUG Rating	B1-U0-G1	B1-U0-G1	B2-U0-G2	B2-U0-G2	B2-U0-G2	B2-U0-G2	B2-U0-G2	B3-U0-G3	B3-U0-G3
	3000K	2,150	3,010	3,912	5,016	5,831	6,524	7,139	7,720	7,737
T3	4000K	2,410	3,373	4,384	5,621	6,534	7,312	8,000	8,652	8,670
	BUG Rating	B1-U0-G1	B1-U0-G1	B1-U0-G1	B1-U0-G2	B1-U0-G2	B2-U0-G2	B2-U0-G2	B2-U0-G2	B2-U0-G2
	3000K	2,133	2,985	3,881	4,976	5,784	6,472	7,082	7,659	7,675
T4W	4000K	2,413	3,377	4,390	5,628	6,542	7,321	8,010	8,663	8,681
	BUG Rating	B1-U0-G1	B1-U0-G1	B1-U0-G2	B1-U0-G2	B1-U0-G2	B2-U0-G2	B2-U0-G2	B2-U0-G2	B2-U0-G2
	3000K	2,136	2,989	3,886	4,982	5,791	6,480	7,090	7,668	7,684
5WQ	4000K	2,510	3,513	4,567	5,855	6,806	7,616	8,333	9,012	9,031
	BUG Rating	B2-U0-G1	B3-U0-G1	B3-U0-G1	B3-U0-G2	B3-U0-G2	B3-U0-G2	B3-U0-G2	B4-U0-G2	B4-U0-G2
	3000K	2,222	3,110	4,043	5,183	6,025	6,742	7,376	7,977	7,994
	BUG Rating	B2-U0-G1	B2-U0-G1	B3-U0-G1	B3-U0-G2	B3-U0-G2	B3-U0-G2	B3-U0-G2	B3-U0-G2	B3-U0-G2

NOTE: * Photometric data is reported for lower hemisphere only.

LUMEN MAINTENANCE

Light Engine	Ambient Temperature	TM-21 Lumen Maintenance (60,000 Hours)	Theoretical L70 (Hours)
AF24-20 to AF24-80	Up to 50°C	>95%	416,000
AF24-90 & AF24-100	Up to 40°C	>90%	205,000

LUMEN MULTIPLIER

Ambient Temperature	Lumen Multiplier
10°C	1.02
15°C	1.01
25°C	1.00
40°C	0.99
50°C	0.96

ORDERING INFORMATION

Sample Number: UTLD-AF24-30-D-U-T3-4N7-7030

Product Family ¹	Light Engine ²	Wattage Bucket	Driver	Voltage	Distribution
UTLD=Traditionaire™ LED Downlight	AF24	20 ³ 30 40 50 60 70 80 90 100	D=Dimming (0-10V) 5LTD=DALI ⁴	U=Universal (120-277V) 2=120V ³ 8=480V ^{5,6} 9=347V ^{5,6}	T2U=Type II Urban T3=Type III T4W=Type IV Wide 5WQ=Type V Square Wide
Options (Add as Suffix)			Color	Accessories (Order Separately)	
[BLANK] =10kV UL 1449 Surge Protection Device ⁷ 10MSP =10kV MOV Surge Protection Device ⁷ 7030 =70 CRI / 3000K CCT ⁸ 4 =NEMA Photocontrol Receptacle ⁹ 4N7 =NEMA 7-PIN Twistlock Photocontrol Receptacle HA =50C High Ambient Temperature ¹⁰ W =20' #10 Leads S =Snap Latches for Tool-less Light Replacement J =Factory Installed Ladder Rest A =Refractive Lens Panels ¹¹ BC =Bird Cone ¹¹ HSS =Factory Install UTLD House Side Shield for AF24 ¹²			[BLANK] =Black ¹³ AP =Grey BZ =Bronze WH =White	TA1BK =Decorative Ladder Rest for Field Installation (Black) OA/RA1013 =NEMA Photocontrol - 120V OA/RA1014 =Photocontrol Shorting Cap OA/RA1016 =NEMA Photocontrol - Multi-Tap OA/RA1027 =NEMA Photocontrol - 480V OA/RA1201 =NEMA Photocontrol - 347V OA1223 =10kV Surge Module Replacement HS-UTLD-24 =Field Installed UTLD House Side Shield for AF24 ¹²	

NOTES:

1. Customer is responsible for engineering analysis to confirm pole and fixture compatibility for all applications. Refer to our white paper WP513001EN for additional support information.
2. Standard 4000K CCT and nominal 70 CRI.
3. AF24-20 only available in 120V.
4. Only available in universal voltage. Consult your lighting representative at Eaton if custom programming is required. Not available with AF24-90, AF24-100. Consult your lighting representative at Eaton if greater than AF-80 (83W) is needed.
5. Only for use with 480V Wye systems. Per NEC, not for use with ungrounded systems, impedance grounded systems or corner grounded systems (commonly known as Three Phase Three Wire Delta, Three Phase High Leg Delta and Three Phase Corner Grounded Delta systems).
6. Not available with 5LTD driver.
7. 10kV UL 1449 Surge Protection Device standard unless 10MSP option specified.
8. Use dedicated IES files for 3000K when performing layouts. These files are published on the UTLD Traditionaire product page on the website.
9. If "4" selected, dimming functionality not available, dimming leads will be capped.
10. Not available with HSS or 5LTD driver.
11. Refractive lens panels and bird cone cannot be ordered together.
12. HSS not available with 5WQ distribution.
13. Black finish standard unless other color option specified.

USSL

LED area, site and roadway luminaire

Streetworks



Innovation you can rely on™

Prevailing innovation. Remarkable savings.

Redefining area/site and roadway lighting efficiency and performance

The USSL LED luminaire delivers a new level of performance and versatility in a low profile, modern style resulting in significant installation and energy savings. Incorporating industry-leading, patented optics, the USSL LED luminaire offers a choice of four precision engineered optical distributions that deliver superior control and maximize light levels, whether the application is a parking lot or a pedestrian walkway.

Innovation beyond the fixture

The USSL LED luminaire features several mounting configurations that provide design flexibility while simplifying installation. Innovative in form and function, the USSL LED luminaires' standard versatile mount arm gets you install ready out of the box. With the ability to accommodate multiple drilling patterns as well as square and round poles, the standard versatile mount arm is the choice for both retrofit and new applications.

Advanced design delivers savings

With a single housing that accommodates multiple lumen packages ranging from 6,100 to 15,100 nominal lumens, the USSL LED luminaire provides greater than 62 percent in energy and maintenance savings over traditional HID systems, resulting in significant energy rebates. An optional integrated sensor allows the fixture to be dimmed when no activity is detected, providing additional energy savings by reducing light levels and power consumption, while complying with the provisions of California Title 24.

Engineered for long term reliability

In addition to superior performance, the USSL LED luminaire delivers an innovative thermal management design that maximizes heat dissipation resulting in longer fixture and LED life. Along with lumen maintenance greater than 92 percent at 60,000 hours, the rugged, die-cast fixture housing is 3G vibration and IP66 rated, which provides years of reliable operation with minimal service requirements. Backed by a five-year limited warranty, the USSL LED luminaire is the LED answer to your area, site and roadway lighting needs.



Area/site



Pathway



Wall mount

Value engineered design

The USSL LED luminaire delivers exceptional performance in a scalable, low-profile design. The precision engineered optics provide uniform illumination to walkways, parking lots, roadways, building areas and security lighting applications. Able to replace HID fixtures ranging from 150W up to 400W, the USSL LED luminaire is designed to meet the toughest lighting challenges.

Construction

- Rugged, single-piece, die-cast aluminum housing and driver compartment
- Hinged, tethered power door for ease of maintenance
- 3G vibration rated per ANSI C136.31
- IP66 rated optics and fixture
- UL/cUL wet location rated housing
- One-piece silicone gasket seals driver door to fixture

Electrical

- -40°C to 40°C ambient operating temperature range
- 50°C high ambient option available
- 10kV/10kA non-fused surge protection is standard
- 10kV/10kA, UL 1449 fused surge protection optional
- 120-277V 50/60Hz, 347V 60Hz or 480V 60Hz operation
- 0-10V dimming driver (standard)

Optical

- Three lumen package ranging from 6,100 - 15,100 nominal lumens
- Type II, III, IV and V distributions
- Greater than 92 percent lumen maintenance at 60,000 hours
- Delivers unparalleled uniformity and scalability
- Optional house side shield available for backlight control

Controls

- Controls-ready when equipped with ANSI 7-PIN twistlock photocontrol receptacle
- 3-PIN twistlock photocontrol receptacle available
- Optional integrated sensor for occupancy and dimming
- Optional LumaWatt wireless control and monitoring system

Mounting

- Standard versatile mounting arm accommodates multiple drilling patterns as well as square and round poles
- Easily retrofits to poles with drill patterns ranging from 1-1/2" to 4-7/8"
- Optional wall-mount arm with adapter plate is available
- Optional cast aluminum mast arm mounting adapter available

Finish

- Five-stage super TGIC paint resists extreme weather conditions while providing optimal color and gloss retention
Available in grey, bronze, black, dark platinum, graphite metallic or white

Warranty

- Five-year warranty

Optional features



Wireless control and monitoring system

Sensor capable of motion and photo sensing, metering power consumption and wireless communication.



Integrated sensor

Optional integrated sensor is capable of occupancy and dimming resulting in the reduction of energy required for area/site lighting applications.



NEMA 3-PIN photocontrol receptacle

Gasketed receptacle for mounting standard 3-PIN NEMA photocontrol.



NEMA 7-PIN photocontrol receptacle

ANSI C136.41 compliant. Enables wireless dimming when used with compatible photocontrol.

A01 (Single LED = 6,100 nominal lumens)
A02/G-A02 (Dual LEDs = 10,200/15,100 nominal lumens)

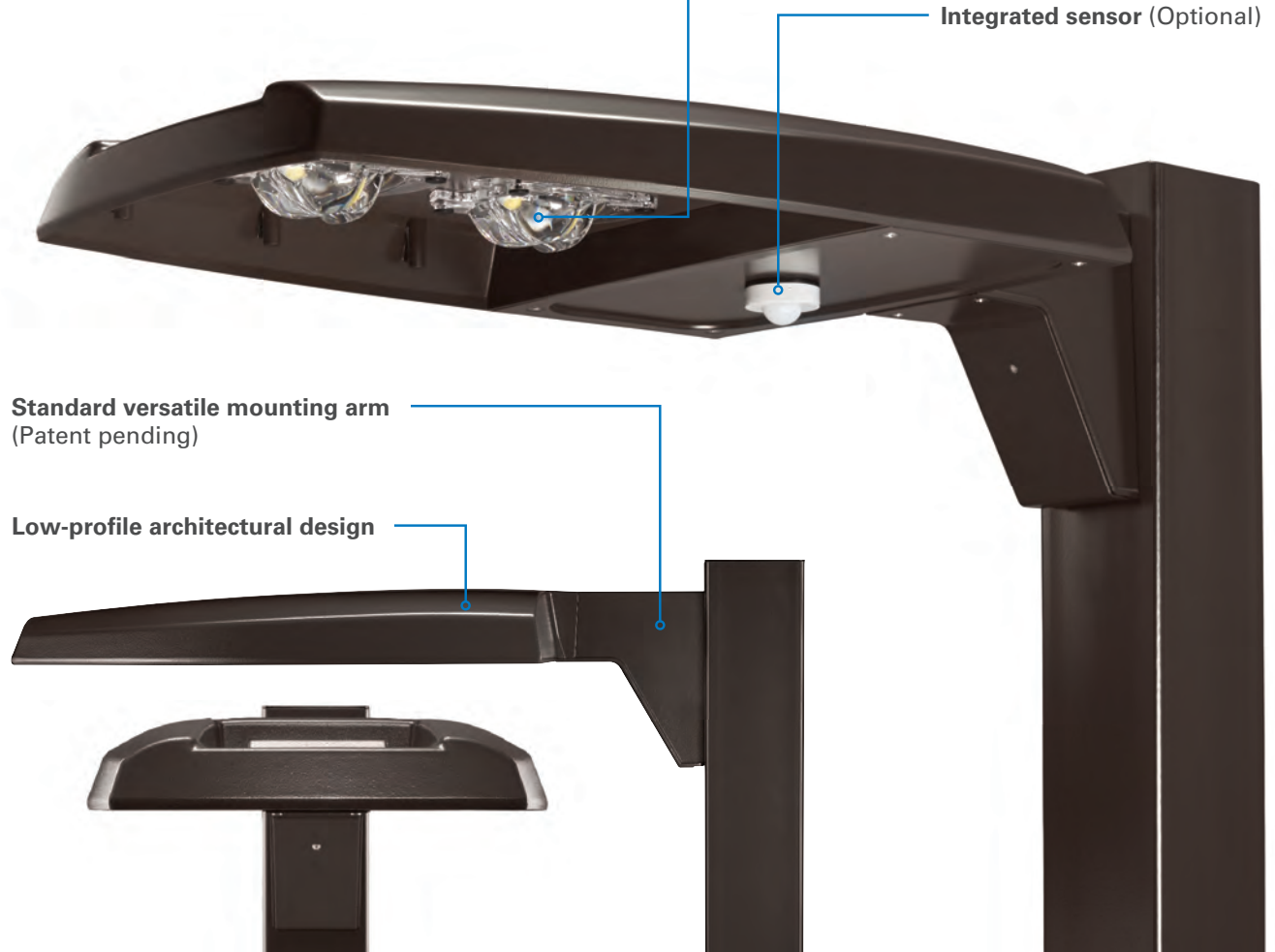

Mounting options



House side shield

For stringent light trespass requirements and the ultimate level of backlight control, a house side shield accessory is available for factory or field installation.



Arm mount

Versatile mounting arm is simple to install and can be used with existing poles for retrofit installations.



Wall mount

Wall mount option utilizes an adapter plate secured to wall with four bolts for perimeter lighting applications (Bolts not included).



Mast arm mount

An optional cast aluminum mast arm adapter secures fixture head to nominal 2" (2-3/8" O.D. pipe size) horizontal steel tenon arm for roadway applications.

Retrofit and installation has never been easier

Time is money when it comes to installing and retrofitting area and site luminaires. The USSL luminaire's patent pending standard versatile mounting arm was engineered to make installation quick and easy, saving on both installation time and costs. Optional, wall and mast arms are also available for even more design flexibility for any building mount, street and roadway applications.

Retrofits multiple drill patterns

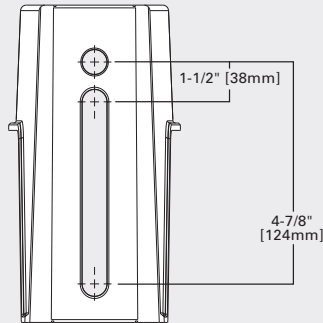

- Standard versatile arm can accommodate any existing drill pattern ranging from 1-1/2" to 4-7/8"
- Simply remove the existing luminaire and install the versatile arm to the existing top bolt location
- Align the slot to the existing 2nd bolt location and bolt into place
- Installation requires zero field drilling of the pole, saving time and money

1

Simply install the luminaire

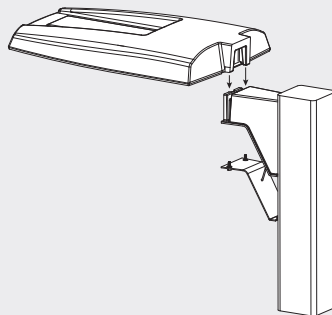

- Simply slide the USSL luminaire onto the installed versatile arm and secure with a single screw
- The versatile mounting arm's door is tethered and includes captive fasteners to prevent accidental dropping
- The USSL luminaire can be easily mounted and installed by a single person due to the innovative and simple versatile arm design

2

Safe and secure completion

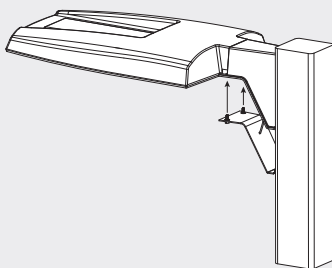

- Ample space is provided within the USSL's arm to access and wire the luminaire
- Make the necessary wiring connections and reattach the tethered arm cover to complete installation
- There is zero need to access the driver compartment during installation, insuring a reliable, secure and safe installation

3

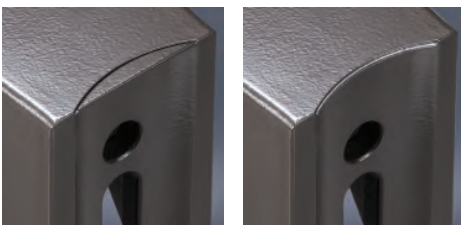

Universal pole mounting

The versatile mounting arm includes integrated breakaway tabs to accommodate both square or round poles. Installation does not require an additional pole adapter plate, which simplifies the ordering and installation process for both retrofit and new construction applications.

Application excellence

Uniform illumination

Easily replacing a 400W HID site fixture, the USSL LED luminaire is the solution whether retro-fitting an existing site or lighting a new location. Four optical distributions allow the lighting designer to put light exactly where it's needed without wasting energy with extra light spilling onto unwanted locations. An optional house-side shield is available when extreme cut-off is needed at the property lines. Parking areas must be designed to provide safety and security to both pedestrians and vehicular traffic. Good exterior lighting design will deter criminals, and attract patrons all while limiting light pollution. The IESNA has provided two documents to aid in proper parking lot lighting design; RP-20 lighting for parking facilities and RP-33 lighting for exterior environments. Proper illumination levels for site and area design are achieved by maintaining an absolute minimum illuminance level at any given point within the site, while holding an acceptable maximum-to-minimum uniformity levels. The USSL LED luminaire is ideal for parking lots, small retail, security, and roadway applications.

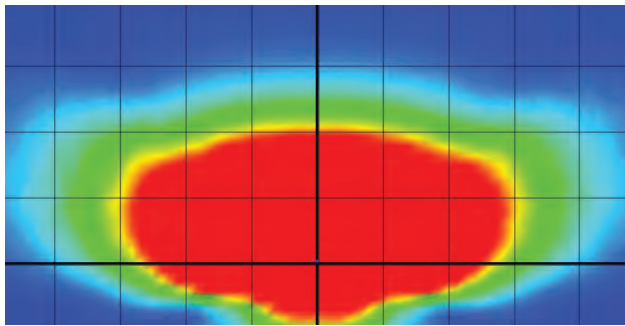

USSL G-A02 LED (Type III shown)

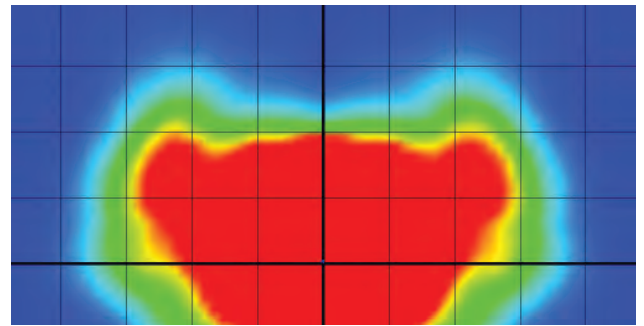

400W Pulse Start Metal Halide (Type III shown)

Greater than 68 percent in HID to LED retrofit savings

The following comparison shows the USSL LED G-A02 luminaire and a 400W pulse start metal halide shoebox type luminaire in a typical parking lot application. All fixtures are at the same mounting height and locations. The same number of poles and fixture heads are used to calculate a one-for-one direct comparison. The USSL LED luminaire not only provides a higher minimum and much more uniform layout, but it also provides more than 68 percent in energy savings over the HID solution.



USSL G-A02 LED
 14 Fixtures = 2,002 Total watts



400W Pulse Start Metal Halide
 14 Fixtures = 6,370 Total watts

Site Lighting Comparison Numbers

Fixture / Source	Number of Fixtures	Total Site Wattage	Average (Footcandles)	Maximum (Footcandles)	Minimum (Footcandles)	Uniformity	
						Avg. / Min.	Max. / Min.
USSL-G-A02 LED	14	2,002	1.63	3.88	0.50	3.26	7.76
400W Pulse Start Metal Halide	14	6,370	2.02	7.84	0.03	67.33	261.33

* 25' mounting height.

Dimming and occupancy



Area/site applications

For outdoor area/site applications, lighting should be dimmed or turned off according to pedestrian traffic and safety requirements. Scheduled dimming and occupancy detection can be combined to reduce maximum lighting levels outside business hours. Upon occupancy detection, the luminaire returns to full lighting to maintain security lighting levels.

Minimize power consumption, maximize energy savings

To further enhance energy savings, lighting management and control can reduce power consumption and energy costs by providing the appropriate light levels at the right place and time when required. Lighting can be reduced during low usage hours, saving energy, then raised on demand with occupancy detection. Adding motion sensor and dimming controls capabilities also extends the life of the luminaire due to reductions in electrical load and case temperatures on the LEDs and drivers. The USSL LED area, site and roadway luminaires control options are designed to be simple and cost-effective ASHRAE and California Title 24 compliant solutions.

On/off or bi-level motion sensor (MSP)

The USSL LED area, site and roadway luminaires integrated dimming and occupancy sensor is a standalone control option that can automatically dim the luminaire to 50 percent with a time delay of 10 minutes if no occupancy is detected. When activity is detected, the luminaire returns to full light output. This option is available in 12' - 30' mounting heights in on/off operation or bi-level operation. To change these settings, a hand held programmable remote can be purchased that allows the dimming level, sensitivity and time delay settings to be adjusted.

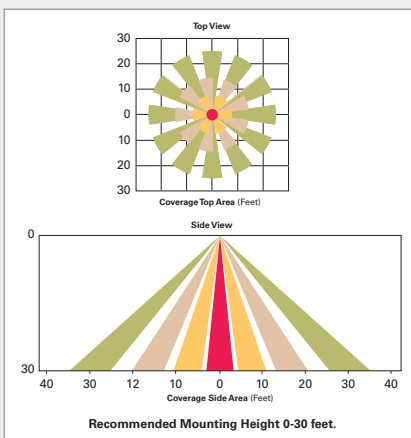

Worry-free controls planning

Ensure complete coverage and performance with an integrated sensor system built into every luminaire based on fixture mounting height. The integrated sensor is available in mounting heights from 12-30'.

Integrated design

With a single product to mount, and a single electrical connection to make, the USSL LED luminaire with an integrated sensor system saves money on the total installed cost when occupancy and daylight dimming controls are needed.

Sensor remote control

When the application demands more, the sensor system has the option to make changes using a remote control. The remote allows changes from the default settings for occupied/unoccupied, target light level, and time outs.

Lighting management and control



Light level automation

A 30-50 percent reduction of energy use is not uncommon as a result of combining basic lighting control strategies. The LumaWatt system employs four control strategies to automate luminaire behavior: Scheduled ON/OFF, Scheduled Dimming, Occupancy Detection and Daylight Harvesting.

Lumawatt outdoor wireless control and monitoring system

Different environments pose different challenges when balancing power reduction against usage requirements. Lighting management and control can minimize power consumption and energy costs by providing the right light levels where and when they're needed. Standards and codes, such as, ASHRAE and Title 24, provide guidance for the automation of lighting systems but taking advantage of these can be complicated. To be effective, lighting management control systems need to be simple, flexible and reliable. The LumaWatt system offers the perfect combination of features that eliminates the need for remote sensors, reducing installation costs and commissioning time. Multi-functional sensors are factory-installed and tested in each luminaire so reliability, area coverage and location are never concerns.

The LumaWatt system is a peer-to-peer wireless network of luminaire-integrated sensors, which operate in accordance with stored programmable profiles. Each sensor is capable of motion and photo sensing, metering power consumption and wireless communication. Sensor profiles dictate how the individual luminaires operate, as well as how to function among network peers. The end user can create and manage sensor profiles with browser-based management software and transmit to sensors via wireless gateways.

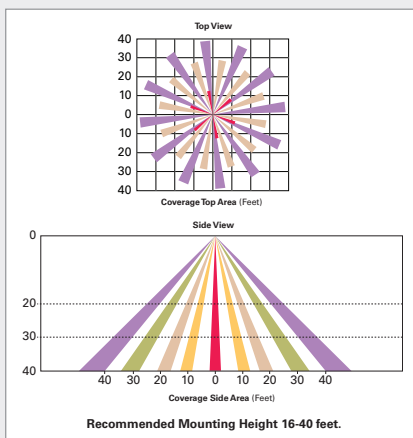

Coverage area

Designed to detect motion within its field-of-view, LumaWatt system sensors are considered line-of-sight sensors, meaning that no obstruction can exist between the sensor and the object being detected. The area of coverage depends on the mounting height determined from a chart of its detection pattern.



Sensor module

The LumaWatt system sensor is available with two passive infrared sensor geometries—wide for mounting heights of 8' to 16' and narrow for 16' to 40'. Sensors are factory installed in every luminaire for reliability, saving installation time.



Monitoring system

Management software creates and manages sensor profiles via easy-to-use, web-based software, providing summaries of power metering and system performance.

Energy savings

Reduced energy consumption

Operating and maintenance costs of a lighting system are dramatically impacted by the specified lamp source, system power consumption and the duration time of operation. Total system input watts and fixture operating life should be the driving considerations when addressing energy consumption and total cost of ownership. Energy savings increase when energy consumption is reduced and maintenance intervals are extended.

Annualized Energy Savings / Cost Comparison

Product	Hours Days / Year	Input Watts	TM-21 Data / HID Life (Hours)	Cost / Year at \$.10 kWh ¹	Annual Maintenance Cost ²	Total Energy Cost/Fixture and Maintenance	Annual Savings Per Fixture	Savings (Percent)
G-A02 USSL LED Site Light	11 / 4,015	143W	60,000	\$57.41	--	\$57.41	\$186.07	76%
400W Metal Halide Site Light		458W	20,000	\$183.89	\$59.60	\$243.49		
A02 USSL LED Site Light	11 / 4,015	87W	60,000	\$34.93	--	\$34.93	\$158.57	82%
250W Metal Halide Site Light		290W	15,000	\$116.44	\$77.07	\$193.50		
A01 USSL LED Site Light	11 / 4,015	57W	60,000	\$22.89	--	\$22.89	\$109.20	83%
150W Metal Halide Site Light		190W	20,000	\$76.29	\$55.80	\$132.09		

NOTE: 1. Cost = (Watts x 11 Hours Per Day x 365 Days Per Year / 1000 = Daily Kilowatt hour (kWh), kWh x 0.10 cents/kWh = Cost / Year. 2. Maintenance = number of relamps over 60,000 hours (15 years) x lamp cost and replacement labor /15 years.

Energy Savings / Equivalency / Cross Reference Guide

USSL	HID Replacement Options	Lamp System	HID Wattage	HID Rated Average Life (Hours)	USSL LED Wattage	USSL TM-21 Data (Hours) *	Energy Savings (Percent)
USSL-G-A02	320W - 400W HID	320W Metal Halide	377W	20,000	143W	>L90 @ 60,000	62%
		350W Metal Halide	397W	20,000			64%
		400W Metal Halide	458W	20,000			69%
		400W High Pressure Sodium	464W	24,000			69%
USSL-A02	200W - 250W HID	200W Metal Halide	232W	15,000	87W	>L90 @ 60,000	63%
		200W High Pressure Sodium	240W	24,000			64%
		250W Metal Halide	290W	15,000			70%
		250W High Pressure Sodium	295W	24,000			71%
USSL-A01	100W - 175W HID	100W Metal Halide	130W	20,000	57W	>L90 @ 60,000	56%
		150W Metal Halide	190W	20,000			70%
		150W High Pressure Sodium	170W	24,000			66%
		175W Metal Halide	210W	14,000			73%

NOTE: * Lumen maintenance for LED at 40° ambient temperature. TM-21 hour data based on six times number of hours LED chip test time.

Utility incentive programs

Utility companies (power providers) are leading the way in responding to climate change and the power sector's role in reducing greenhouse gases while meeting the country's growing energy needs. Utilities offer customers incentives to install high-efficiency luminaires that reduce the demand for power in their areas. The USSL LED luminaire qualifies for a majority of these incentive programs. There are two types of incentive programs offered. Prescriptive incentive programs provide a specific predetermined dollar amount for each fixture replaced. Custom rebates are based on the total energy savings for a specific project.

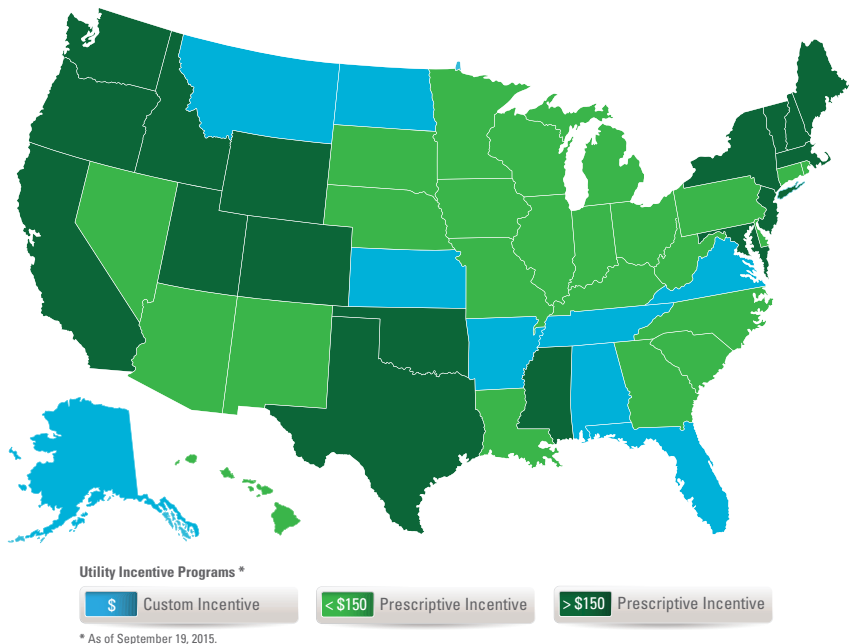

Ordering information

Sample Number: USSL-A02-D-U-T3-SA-BZ-4N7-10K

Product Family ^{1,2}	Light Engine ³	Driver ⁴	Voltage	Distribution	Mounting	Color ⁶
USSL	A01=(1 LED) 6,100 Nominal Lumens A02=(2 LEDs) 10,200 Nominal Lumens G-A02=(2 LEDs) 15,100 Nominal Lumens	D=Dimming (0-10V)	U=Universal (120-277V) 9=347V 8=480V ⁵	T2=Type II T3=Type III T4=Type IV T5=Type V	SA=Standard Versatile Arm MA=Mast Arm WM=Wall Mount Arm	AP=Grey BZ=Bronze BK=Black DP=Dark Platinum GM=Graphite Metallic WH=White
Options (Add as Suffix)				Accessories (Order Separately) ¹³		
7030=70 CRI / 3000K CCT ⁷ 7050=70 CRI / 5000K CCT ⁷ 10K=10kV/10kA UL 1449 Fused Surge Protective Device 10MSP=10kV MOV Surge Protection ⁸ DIMRF-LW=LumaWatt Wireless Sensor, Wide Lens for 8' - 16' Mounting Height ^{9,10,11} DIMRF-LN=LumaWatt Wireless Sensor, Narrow Lens for 16' - 40' Mounting Height ^{9,10,11} MSP/DIM-L12=Integrated Sensor for Dimming Operation, 8' - 12' Mounting Height ¹¹ MSP/DIM-L30=Integrated Sensor for Dimming Operation, 12' - 30' Mounting Height ¹¹ MSP-L12=Integrated Sensor for ON/OFF Operation, 8' - 12' Mounting Height ¹¹ MSP-L30=Integrated Sensor for ON/OFF Operation, 12' - 30' Mounting Height ¹¹ 4=NEMA 3-PIN Twistlock Photocontrol Receptacle ¹² 4N7=NEMA 7-PIN Twistlock Photocontrol Receptacle ¹² HSS=House Side Shield TH=Tool-less Hardware HA=50°C High Ambient Temperature				PRVWM-XX=Wall Mount Kit PRVMA-XX=Mast Arm Mounting Kit PRVSA-XX=Standard Versatile Mounting Kit HS/VERD=House Side Shield MA1010-XX=Single Tenon Adapter for 3-1/2" O.D. Tenon MA1011-XX=2 @ 180° Tenon Adapter for 3-1/2" O.D. Tenon MA1012-XX=3 @ 120° Tenon Adapter for 3-1/2" O.D. Tenon MA1013-XX=4 @ 90° Tenon Adapter for 3-1/2" O.D. Tenon MA1014-XX=2 @ 90° Tenon Adapter for 3-1/2" O.D. Tenon MA1015-XX=2 @ 120° Tenon Adapter for 3-1/2" O.D. Tenon MA1016-XX=3 @ 90° Tenon Adapter for 3-1/2" O.D. Tenon MA1017-XX=Single Tenon Adapter for 2-3/8" O.D. Tenon MA1018-XX=2 @ 180° Tenon Adapter for 2-3/8" O.D. Tenon MA1019-XX=3 @ 120° Tenon Adapter for 2-3/8" O.D. Tenon MA1045-XX=4 @ 90° Tenon Adapter for 2-3/8" O.D. Tenon MA1048-XX=2 @ 90° Tenon Adapter for 2-3/8" O.D. Tenon MA1049-XX=3 @ 90° Tenon Adapter for 2-3/8" O.D. Tenon MA1191-XX=2 @ 120° Tenon Adapter for 2-3/8" O.D. Tenon OA/RA1013=Photocontrol Shorting Cap OA/RA1014=NEMA Photocontrol - 120V OA/RA1016=NEMA Photocontrol - Multi-Tap 105-285V OA/RA1027=NEMA Photocontrol - 480V OA/RA1201=NEMA Photocontrol - 347V ISHH-01=Integrated Sensor Programming Remote		

NOTES: 1 Customer is responsible for engineering analysis to confirm pole and fixture compatibility for all applications. Refer to installation instructions IB500002EN and pole white paper WP513001EN for additional support information. 2 DesignLights Consortium™ Qualified and classified for both DLC Standard and DLC Premium, refer to www.designlights.org for details. 3 Standard 4000K CCT and 70 CRI. 4 Consult factory for driver surge protection values. 5 Only for use with 480V Wye systems. Per NEC, not for use with ungrounded systems, impedance grounded systems or corner grounded systems (commonly known as Three Phase Three Wire Delta, Three Phase High Leg Delta and Three Phase Corner Grounded Delta systems). 6 Different housing colors impact lumen output. IES files for the non-standard colors are available upon request. 7 Extended lead times apply. Use dedicated IES files for 3000K and 5000K when performing layouts. These files are published on the USSL luminaire product page on the website. 8 Not available with 347V or 480V. 9 LumaWatt wireless sensors are factory installed and require network components RF-EM-1, RF-GW-1 and RF-ROUT-1 in appropriate quantities. See website for LumaWatt application information. 10 LumaWatt wireless system is not available with photocontrol receptacle (Not needed). 11 Terminal block is not offered with these options. Not offered with photocontrol 4 or 4N7 options. 12 Not available with MSP or DIMRF options. 13 Replace XX with paint color.

Dimensions

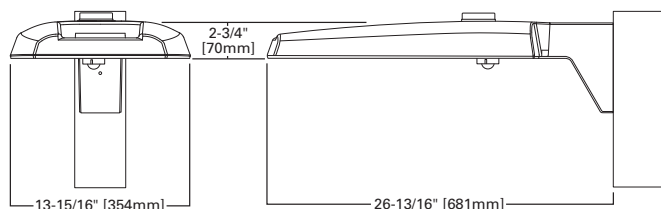

Additional Information

Compliances	Technical Data (Electronic Driver)
UL and cUL Wet Location Listed IP66-Rated Optics and Fixture 3G Vibration Rated per ANSI C136.31 ISO 9001 DesignLights Consortium™ Qualified ¹	+40°C (104°F) Ambient Temperature Rating -40°C (-40°F) Ambient Temperature Rating >0.9 Power Factor <20% Total Harmonic Distortion 120-277V 50/60Hz 347V 60Hz, 480V 60Hz ²
EPA (Effective Projected Area - Square Feet)	Shipping Data (Approximate Net Weight)
0.75	20 lbs. (9.09 kgs.)

NOTES: 1 DesignLights Consortium™ Qualified and classified for both DLC Standard and DLC Premium, refer to www.designlights.org for details. 2 480V is compatible for use with 480V Wye systems only.

Versatile Pole Mount Arm (SA)

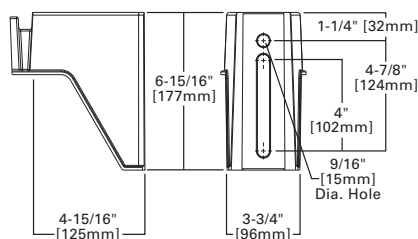

Wall Mount Arm (WM)

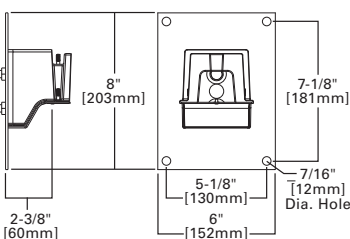

Mast Arm Mount (MA)

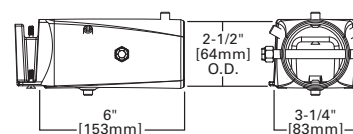

NOTE: Specifications and dimensions subject to change without notice.

**Our Lighting
Product Lines**

Halo
Halo Commercial
Portfolio
Iris
RSA
Metalux
Corelite
Neo-Ray
Fail-Safe
MWS
Ametrix
Shaper
io
Lumark
McGraw-Edison
Invue
Lumière
Streetworks
AtLite
Sure-Lites

**Our Controls
Product Lines**

Greengate
iLumin
Zero 88
Fifth Light Technology
iLight (International Only)

Eaton
1121 Highway 74 South
Peachtree City, GA 30269
P: 770-486-4800
www.eaton.com/lighting

Canada Sales
5925 McLaughlin Road
Mississauga, Ontario L5R 1B8
P: 905-501-3000
F: 905-501-3172



© 2015 Eaton
All Rights Reserved
Printed in USA
Publication No. BR500008EN
December 2015

Eaton is a registered trademark.

All other trademarks are property
of their respective owners.

Product availability, specifications,
and compliances are subject to
change without notice.

Caretaker™
LED Area Luminaire

STREETWORKS



Cooper Lighting
by **EAT•N**

An Economical LED Dusk-to-Dawn Solution

Combining high performance, low maintenance and easy installation, the Caretaker™ LED luminaire is a simple, economical answer for dusk-to-dawn lighting needs. Designed for years of worry-free operation, the Caretaker luminaire is the perfect area lighting solution for both full-cutoff needs, or landmark applications where a highly visible light source is desired.

Construction

- Hinged removable power door for easy maintenance.
Optional tool-less entry available
- LED driver is mounted directly to removable door
- Fully compatible with ANSI/NEMA open-bottom refractor
- IP66 rated LED module
- UL wet location rated housing
- Rugged, die-cast aluminum construction
- NEMA photocontrol receptacle
- Two-bolt mounting for 1-1/4" to 2" standard pipe
(1-5/8" to 2-3/8" O.D.)

Performance and Electrical

- -40°C to 40°C ambient operating temperatures
- 6kV/3kA IEEE 62.41 Class C low surge protection with
10kV/10kA Class C high surge protection available
- L86 36,000 hours at 25°C, compliant with IESNA TM-21
- 120V/60Hz operation

Warranty

- Five-year warranty



Innovation you can rely on™



Hinged Removable Power Door

Driver is mounted to the door. Power door hangs securely and can be easily removed.

A 6kV/3kA surge protection is integral to driver.

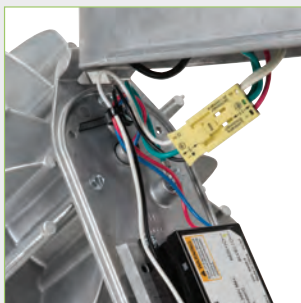

Quick Disconnects

Connections between power door and housing are made with tool-less quick disconnects.



ANSI/NEMA Refractor Compatible

Fixture works with standard ANSI/NEMA open-bottom refractor.



Optional Surge Protection

Optional UL 1449 Listed 10kV/10kA surge protective device protects against common (line-to-ground) and differential (line-to-line) mode surges.

Ordering Information

Sample Number: CRTK-A-A08-E-120-5-SR-A

Product Family	Lumen Package	Driver	Voltage	Distribution
CRTK-A=Caretaker Dusk-to-Dawn Area Luminaire	A08=8 LEDs A12=12 LEDs ¹	E=Non-Dimming	120=120V	5=Type V
Options (Add as Suffix)		Color	Accessories (Order Separately)	
S=Shorting Cap 5=120V NEMA Photocontrol Included 10K=10kV UL 1449 Surge Protection Device UL=UL/CSA Listed SR=Small Acrylic Refractor Included	B18=18" Wood Pole Pipe Arm B24=24" Wood Pole Pipe Arm B30=30" Wood Pole Pipe Arm TH=Tool-less Door Hardware WPBKT=Wall or Wood Pole Mounting Bracket V=(2) 5' #14 Leads 5000=5000K CCT	AP=Grey BZ=Bronze BK=Black DP=Dark Platinum GM=Graphite Metallic WH=White A=Raw Aluminum Unfinished (Standard) ¹	RMARROA5=ANSI/NEMA Standard Refractor Assembly SR-CARETAKER=Small Acrylic Refractor	

NOTE: 1 Paint required for 12 LEDs at 40°C ambient. Maximum ambient temperature for 12 LEDs unpainted is 25°C.

Dimensions

Full Cutoff

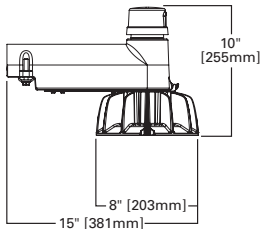

Small Acrylic Refractor

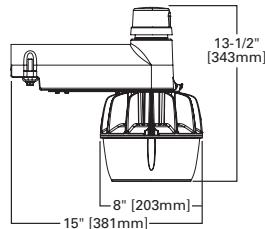

ANSI/NEMA Standard Refractor Assembly

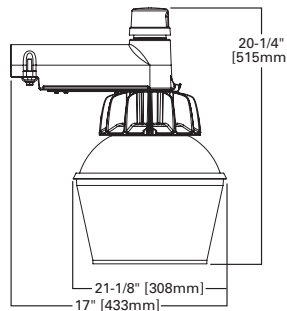

Optional Wood Pole Pipe Arm

18", 24" or 30" Pipe Arm

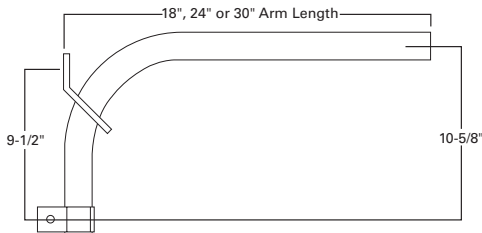

Power and Lumens

Luminaire Wattage (Nominal)		48W	73W
Type V	Lumens	4,814	6,910
	BUG Rating	2-0-1	3-0-1
Type V with SR	Lumens	4,674	6,630
	BUG Rating	3-3-2	3-3-2

Lumen Maintenance (8 LEDs)

Ambient Temperature	TM-21 Lumen Maintenance (36,000 Hours)	Theoretical L70 (Hours)
25°C	> 86%	87,000
40°C	> 84%	72,000

Lumen Maintenance (12 LEDs)

Ambient Temperature	TM-21 Lumen Maintenance (36,000 Hours)	Theoretical L70 (Hours)
25°C	> 83%	69,000
40°C*	> 82%	66,000

* Painted only.

Additional Information

Compliances	Technical Data (Electronic LED Driver)	EPA Effective Projected Area (Square Feet)	Shipping Data (Approximate Net Weight)
UL and cUL Wet Location Listed IP66 Rated LED Module 3G Vibration Rated ARRA Compliant DesignLights Consortium® Qualified	>0.9 Power Factor <20% Total Harmonic Distortion 120V 50/60Hz -40°C Minimum Ambient Temperature Rating +25°C Maximum Ambient Temperature Rating	0.67	8.0 lbs. (3.6 kgs.)



NOTE: Specifications and dimensions subject to change without notice.

Eaton's Cooper Lighting Business

Headquarters
1121 Highway 74 South
Peachtree City, GA 30269
P: 770-486-4800
www.cooperlighting.com

Canada Sales
5925 McLaughlin Road
Mississauga, Ontario L5R 1B8
P: 905-501-3000
F: 905-501-3172

Our Lighting Product Brands

Halo
Halo Commercial
Portfolio
IRiS
RSA
Metalux
Corelite
Neo-Ray
Fail-Safe
MWS
Ametrix
Shaper
io
Lumark
McGraw-Edison
Invue
Lumière
Streetworks
AtLite
Sure-Lites

Our Controls Product Brands

Greengate
iLumin
Zero 88
Fifth Light Technology
iLight (International Only)

Streetworks

DESCRIPTION

Compliments roadways, parks, pedestrian walkways, and residential streets. The Utility LED Acorn illuminates and delights communities with superior LED lumen performance in a traditional, easy-to-service design that replaces 100W HPS fixtures.

Catalog #		Type
Project		
Comments		Date
Prepared by		

SPECIFICATION FEATURES

Construction

Heavy-duty cast aluminum housing and removable door. ANSI C136.31 testing compliance prevents damage from installation generated vibration. A single quarter turn fastener on the removable door provides tool-less access to wiring compartment.

Optics

GLOBE: 9" Visual Comfort textured acrylic globe is standard. Available in asymmetric or symmetric distributions. Offered standard in 4000K CCT and minimum 70 CRI.

Electrical

120-277V 50/60Hz operation. 10kV/10kA common - and differential mode surge protection standard. Thermal management transfers heat rapidly away from the LED source for optimal efficiency and light output. Ambient operating temperature from -40°C to 40°C. Standard three-position tunnel type compression terminal block.

Controls

0-10V dimming driver standard. Photocontrol and After Hours Dim accessories available. Refer to control options section.

Mounting

Post top mount fits 3" O.D. tenon. Secured by square head 3/8" stainless steel mounting bolts.

Warranty

Five-year warranty.



ULA
UTILITY LED
ACORN

DECORATIVE POST TOP
LUMINAIRE

DIMENSIONS

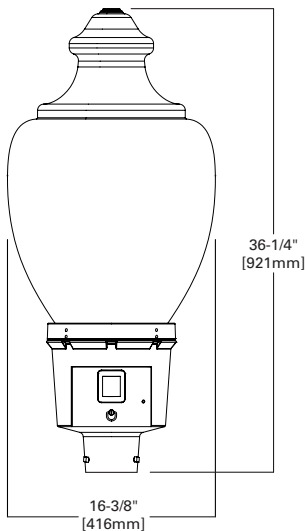

CERTIFICATION DATA

UL/cUL Listed for Fixture Mounting
 Heights 12 ft and greater
 ANSI C136.31/C136.15
 3G Vibration Rated
 ISO 9001

ENERGY DATA

Electronic LED Driver
 >0.9 Power Factor
 <20% Total Harmonic Distortion
 120-277V 50/60Hz
 -30°C Minimum Temperature
 40°C Ambient Temperature Rating

EPA

Effective Projected Area: (Sq. Ft.) 1.72

SHIPPING DATA

Approximate Net Wt:
 16 lbs. (7.3 kgs.)

POWER AND LUMENS

Light Engine	A3	A4	A5	A6	A7	A8	
Nominal Power (Watts)	21	29	36	44	55	56	
Wattage Label	20	30	40	40	60	60	
Current (a) @120V	178 mA	244 mA	309 mA	379 mA	462 mA	471 mA	
Current (a) @277V	90 mA	128 mA	158 mA	192 mA	235 mA	240 mA	
SYM	4000K	3,295	4,070	4,998	5,951	7,032	8,423
	BUG Rating	B1-U5-G2	B1-U5-G3	B1-U5-G3	B2-U5-G3	B2-U5-G3	B2-U5-G3
	3000K	3,183	3,931	4,828	5,748	6,793	8,136
	BUG Rating	B1-U5-G2	B1-U5-G2	B1-U5-G3	B2-U5-G3	B2-U5-G3	B2-U5-G3
	2700K	3,024	3,735	4,586	5,461	6,453	7,729
BUG Rating	B1-U5-G2	B1-U5-G2	B1-U5-G3	B2-U5-G3	B2-U5-G3	B2-U5-G3	

Light Engine	A3	A4	A5	A6	A7	A8
Nominal Power (Watts)	21	30	37	46	56	57
Wattage Label	20	30	40	50	60	60
Current (a) @120V	182 mA	250 mA	314 mA	390 mA	475 mA	480 mA
Current (a) @277V	81 mA	118 mA	144 mA	173 mA	212 mA	214 mA

Optics							
ASYM	4000K	3,122	3,866	4,687	5,488	6,357	7,989
	BUG Rating	B1-U5-G3	B1-U5-G3	B1-U5-G3	B1-U5-G3	B1-U5-G3	B1-U5-G4
	3000K	3,016	3,734	4,527	5,301	6,140	7,717
	BUG Rating	B1-U5-G3	B1-U5-G3	B1-U5-G3	B1-U5-G3	B1-U5-G3	B1-U5-G4
	2700K	2,865	3,548	4,301	5,036	5,833	7,331
BUG Rating	B1-U5-G2	B1-U5-G3	B1-U5-G3	B1-U5-G3	B1-U5-G3	B1-U5-G3	

LUMEN MAINTENANCE

Light Engine	Ambient Temperature	TM-21 Lumen Maintenance (60,000 hours)	Theoretical L70 (Hours)
ULA-A8-D-U-ASYM	40°C	>73%	71,000
ULA-A5-D-U-ASYM	40°C	>85%	139,000

LUMEN MULTIPLIER

Ambient Temperature	Lumen Multiplier
10°C	1.02
15°C	1.01
25°C	1.00
40°C	0.99
50°C	0.96

ORDERING INFORMATION

Sample Number: ULA-A5-D-U-ASYM-VM-9-7030-4N7-10MSP-W-BK

Product Family ¹	Light Engine ²	Driver	Voltage	Distribution	Globe
ULA=Utility LED Acorn	A3 A4 A5 A6 A7 A8 ²	D=Dimming 5LTD=DALI ²	U=Universal (120-277V)	SYM=Symmetric ASYM=Asymmetric	VM-9=Visual Comfort / Milky Globe, 9" Neck VM-8=Visual Comfort / Milky Globe, 8" Neck
Options (Add as Suffix)			Color		Accessories (Order Separately)
7030=70 CRI / 3000K ³ 7027=70 CRI / 2700K ³ 4=NEMA Photocontrol Receptacle (Internal Mount) ⁴ 4N7=NEMA 7-PIN Photocontrol Receptacle (Internal Mount) ⁴ 10K=10kV UL 1449 Surge Protective Device 10MSP=10kV MOV Surge Protective Device NPC=NEMA Photocontrol - Multi-Tap PSC=Photocontrol Shorting Cap HSS=House Side Shield 180 Degree Cutoff ⁵ W=20' #10 Leads HA=High Ambient ⁶			AP=Grey BK=Black BZ=Bronze WH=White GN=Green		OA/RA1016=NEMA Photocontrol - Multi-Tap OA/RA1013=Photocontrol Shorting Cap OA1223=10kV/10kA UL 1449 Surge Module Replacement ULA-HSS=Field Install House Side Shield 180 Degree Cutoff ⁵

NOTES:

- Customer is responsible for engineering analysis to confirm pole and fixture compatibility for all applications. Refer to our white paper WP513001EN for additional support information.
- A8 not available with DALI.
- Use dedicated IES files for various CCTs and CRIs when performing layouts. These files are published on the Utility LED Acorn luminaire product page on the website.
- Total height of photocontrol/node cannot exceed 4.3".
- Applicable for asymmetric distribution.
- Not available with A8 light engine.

LOUISVILLE GAS AND ELECTRIC COMPANY

**Response to First Request for Information of the
Louisville/Jefferson County Metro Government
Dated November 13, 2018**

Case No. 2018-00295

Question No. 10

Responding Witness: John K. Wolfe

- Q-10. Please refer to KU's response to LFUCG 1-28 in Case No. 2016-00370. On Page 31 of Attachment 1, it provides a recommendation that KU develop a tool to estimate the cost to switch to LED lighting. State whether LG&E has developed a tool to estimate the cost to switch to LED lighting. If not, please state whether LG&E is committed to developing such a tool and when it anticipates that it will accomplish that objective.
- A-10. LG&E has developed a tool that LG&E employees can use to assist customers in estimating the cost to switch to LED lighting.

LOUISVILLE GAS AND ELECTRIC COMPANY

**Response to First Request for Information of the
Louisville/Jefferson County Metro Government
Dated November 13, 2018**

Case No. 2018-00295

Question No. 11

Responding Witness: Robert M. Conroy

- Q-11. The Energy Policy Act of 2005 – Section 135 H.R. 6-39 states that “Mercury vapor lamp ballasts . . . shall not be manufactured or imported after January 1, 2008.” What is the status of LG&E’s inventory for mercury vapor replacement?
- a. When is conversion to from mercury vapor to LED anticipated?
 - b. Please indicate the proposed LED replacement for each MV light and the change in monthly charge as a result of replacement, including any one time charges to the customer.
- A-11. LG&E does not maintain an inventory of mercury vapor fixtures.
- a. See the response to Question No. 7.
 - b. See the response to Question No. 7. All proposed LED options, including the monthly charge and the conversion fee, are listed in rate schedule LS on sheets 35 – 35.2 contained in Tab 4 of the Filing Requirements. See the attachment to the response to Question No. 16b. for recommended comparable LED for each mercury vapor light.

LOUISVILLE GAS AND ELECTRIC COMPANY

**Response to First Request for Information of the
Louisville/Jefferson County Metro Government
Dated November 13, 2018**

Case No. 2018-00295

Question No. 12

Responding Witness: William Steven Seelye

- Q-12. Proposed rates for Underground Lighting Service are broken into two charges, a fixture charge and pole charge. Please provide a comprehensive breakdown of the components in a generic lighting system and identify the respective charge for each component. For example, is the conductor part of the fixture or pole charge? Is a mast arm part of the fixture or pole charge?
- a. If LG&E will begin tracking these categories of material separately, how does LG&E propose to allocate current undepreciated balance of the combined category into separate undepreciated balances for each of the separated categories.
- A-12. See the response to PSC 2-29, part a, for a detailed list of the components and whether they are included in the fixture cost total or the pole cost total.
- a. The costs associated with the new LED light rates are estimated costs, and therefore, no undepreciated balances were used.

LOUISVILLE GAS AND ELECTRIC COMPANY

**Response to First Request for Information of the
Louisville/Jefferson County Metro Government
Dated November 13, 2018**

Case No. 2018-00295

Question No. 13

Responding Witness: Robert M. Conroy

Q-13. In the past, Louisville Metro has used CIAC to pay for the cost of installing underground service with monthly bills charged at the overhead rate.

- a. Will the proposed changes to the LS tariff disrupt this option? If yes, please elaborate.
- b. Does LG&E have an asset inventory that would infrastructure pre-paid by the customer through CIAC?
- c. If Louisville Metro requests an LED conversion of such a light, how would the service be billed under the proposed rates? Provide both monthly and any one time fees.

A-13.

- a. The changes to the LS tariff will not have any impact to this option.
- b. The Company does not have a system that tracks infrastructure pre-paid through CIAC.
- c. Any trenching work paid through CIAC or Excess Facilities would be a one-time payment. The lighting facilities would be charged a fixture, pole, and conversion fee monthly as outlined in the rate schedule LS.

LOUISVILLE GAS AND ELECTRIC COMPANY

**Response to First Request for Information of the
Louisville/Jefferson County Metro Government
Dated November 13, 2018**

Case No. 2018-00295

Question No. 14

Responding Witness: John K. Wolfe

- Q-14. State whether LG&E has a form that is equivalent to KU form KU-17-12a dated 3-18 for Contract for Outdoor Lighting Service. This fillable form provides a cost breakdown worksheet to determine the CIAC and/or EF FEES that could be associated with installation of new LS service. If so, please provide an updated proposed change to this form based on the changes proposed in this case so that Louisville Metro may be able to estimate the proposed changes in costs from the current costs.
- A-14. LG&E has a blank form for the Lighting Service Contract. LG&E does not have a fillable form that provides a cost breakdown worksheet to determine CIAC and/or EF Fees that could be associated with installation of new LS service.

LOUISVILLE GAS AND ELECTRIC COMPANY

**Response to First Request for Information of the
Louisville/Jefferson County Metro Government
Dated November 13, 2018**

Case No. 2018-00295

Question No. 15

Responding Witness: Robert M. Conroy

Q-15. Please refer to Tariff LS on proposed Sheet 35.4. LG&E proposes a new provision in Paragraph 6 that would require a customer to pay LG&E the cost to remove lighting facilities, such as fixtures, poles, or supporting facilities.

- a. Please explain if this when and how this fee will be calculated?
- b. Please clarify that if Louisville Metro requests cancellation of a LS or RLS fixture that has been in service longer than 5 years, under these proposed changes, will there be a fee to cease that service and/or removed the fixture?

A-15.

- a. LG&E proposes to recover the costs to remove a fixture when a customer request removal of a fixture in good working order and does not request replacement of such fixture with an LED. This fee is based on LG&E's actual cost to remove the fixture.
- b. If a customer requests cancellation of a LS or RLS fixture, LG&E shall charge the customer its actual costs to remove the fixture, even if the fixture has been in service longer than 5 years.

LOUISVILLE GAS AND ELECTRIC COMPANY

**Response to First Request for Information of the
Louisville/Jefferson County Metro Government
Dated November 13, 2018**

Case No. 2018-00295

Question No. 16

Responding Witness: John K. Wolfe

Q-16. Please refer to the RLS Tariff beginning on proposed tariff Sheet 35. It states: "In the event restricted fixtures/poles fail and replacements are unavailable, Customer will be given the choice of having Company remove the failed fixture/pole or replacing the failed fixture/pole with other available fixture/pole." The range of lumen output in the new rates complicates a photometric study.

- a. How will LG&E assist municipalities in evaluating roadway illumination for the new LS rate options?
- b. For starters, please provide a cross-reference table that associates all existing rate codes with their LED equivalent(s).

A-16.

- a. LG&E will provide a recommended comparable LED to replace each RLS fixture. LG&E can provide the precise lumens for the LED fixture available at the time of request and will work with the customer to evaluate roadway illumination for the new LS rate options.
- b. See attached.

LOUISVILLE GAS AND ELECTRIC COMPANY

**Response to First Request for Information of the
Louisville/Jefferson County Metro Government
Dated November 13, 2018**

Case No. 2018-00295

Question No. 17

Responding Witness: John K. Wolfe

Q-17. Please refer to Mr. Seelye's testimony at page 38.

- a. Please explain what it means for purposes of this proposal that a "non-LED fixture fails." Does this include bulb failure, ballast failure, or only fixture failure?
- b. Confirm that a customer will not be required to pay an LED Conversion Fee if an RLS light fails to function properly and the light is replaced with an LED fixture.
- c. Please provide approximate time until replacement equipment inventory is exhausted for each of the light types proposed to be moved from Rate LS to Rate RLS.

A-17.

- a. Ballast and/or fixture failure. LG&E will continue to replace HID bulbs so long as the HID fixture remains in good working order.
- b. The customer is not required to pay an LED conversion fee if the RLS fixture fails and is replaced with an LED.
- c. See the response to PSC 2-5.

LOUISVILLE GAS AND ELECTRIC COMPANY

**Response to First Request for Information of the
Louisville/Jefferson County Metro Government
Dated November 13, 2018**

Case No. 2018-00295

Question No. 18

Responding Witness: John K. Wolfe

Q-18. Please refer to testimony of Mr. Seelye, page 39 , lines 6-8. Will the Company be installing LED fixtures with 3-pin, 5-pin, or 7-pin photocell receptacles?

A-18. LG&E will be installing LED fixtures with a 7-pin photocell receptacle.

LOUISVILLE GAS AND ELECTRIC COMPANY

**Response to First Request for Information of the
Louisville/Jefferson County Metro Government
Dated November 13, 2018**

Case No. 2018-00295

Question No. 19

Responding Witness: William Steven Seelye

Q-19. Please refer to Exhibit WSS-5.

- a. Explain how the Company estimated the NBV for Poles.
- b. Explain how the Company estimated the NBV for Fixtures.
- c. Explain how and provide the calculation on how the Company determined the NBV per fixture.
- d. Provide all workpapers to support the information provided in Exhibit WSS-5.

A-19.

- a. The NBV for poles was estimated by calculating the value of poles and fixtures on the system based on current costs and then applying the percentage that poles made up of the current cost total to the 2017 actual net book value of the lighting account.
- b. The NBV of fixtures was estimated by calculating the value of poles and fixtures on the system based on current costs and then applying the percentage that fixtures made up of the current cost total to the 2017 actual net book value of the lighting account.
- c. The NBV per fixture was determined by dividing the Estimated NBV for Fixtures by the number of fixtures.
- d. See the response to PSC 2-29, part a.

LOUISVILLE GAS AND ELECTRIC COMPANY

**Response to First Request for Information of the
Louisville/Jefferson County Metro Government
Dated November 13, 2018**

Case No. 2018-00295

Question No. 20

Responding Witness: John K. Wolfe

- Q-20. Please state how many new public street lights were installed by LG&E for each of the past three years, indicating the types of lights installed and the number of these lights which replaced previously existing street lights, for the following: Louisville Metro and LG&E's entire system.
- A-20. KU has a long-standing practice of maintaining a database of all lighting related activities in Lexington-Fayette County. LG&E and KU do not replicate this practice anywhere else in the service territories. LG&E does not have a business need to track information at this level for public street lights. See the attached chart for the net change (includes removals, installs, and upgrades) in Louisville Metro's lights for the past three years.

Louisville Metro - Net Change in Billed Lights 2016 to Oct 2018

	Jan-16	Jan-17	Net Change 2016 to 2017	Jan-18	Net Change 2017 to 2018	Oct-18	Net Change Jan-18 to Oct-18
Total	24,371	24,351	(20)	24,364	13	24,397	33
LGUM_201 RLS 201: OH MV Open Bottom 4000L Fixture	2	2	0	2	0	2	0
LGUM_203 RLS 203: OH MV Cobra Head 13000L Fixture	1844	1731	-113	1660	-71	1586	-74
LGUM_204 RLS 204: OH MV Cobra Head 25000L Fixture	2610	2442	-168	2327	-115	2256	-71
LGUM_206 RLS 206: UG MV Coach 4000L Decorative	11	11	0	11	0	11	0
LGUM_207 RLS 207: OH MV Directional 25000L Fix	30	29	-1	29	0	29	0
LGUM_208 RLS 208: UG MV Coach 8000L Decorative	371	363	-8	359	-4	357	-2
LGUM_209 RLS 209: OH MV Cobra Head 60000L Fixture	1	1	0	1	0	1	0
LGUM_210 RLS 210: OH MV Directional 60000L Fix	7	7	0	7	0	7	0
LGUM_252 RLS 252: OH MV Cobra/Open Bottom 8000L	1029	1002	-27	976	-26	951	-25
LGUM_266 RLS 266: UG HPS Cobra/Contemp 28500L	1333	1328	-5	1324	-4	1322	-2
LGUM_267 RLS 267: UG HPS Cobra/Contemp 50000L	498	481	-17	474	-7	472	-2
LGUM_274 RLS 274: UG HPS Coach/Acorn 9500L Deco	600	600	0	600	0	603	3
LGUM_275 RLS 275: UG HPS Cobra/Contemp 16000L	84	84	0	82	-2	82	0
LGUM_276 RLS 276: UG HPS Coach/Acorn 5800L Deco	43	43	0	43	0	43	0
LGUM_277 RLS 277: UG HPS Coach/Acorn 16000L Deco	251	251	0	251	0	251	0
LGUM_314 RLS 314: UG MV Cobra Head 13000L Deco	414	388	-26	374	-14	367	-7
LGUM_315 RLS 315: UG MV Cobra Head 25000L Deco	441	416	-25	415	-1	413	-2
LGUM_318 RLS 318: UG MV Cobra Head 8000L Deco	49	46	-3	44	-2	42	-2
LGUM_348 RLS 348: UG Inc Continental Jr 6000L Dec	39	39	0	39	0	39	0
LGUM_349 RLS 349: UG Inc Continental Jr 1500L Dec	17	17	0	16	-1	16	0
LGUM_413 LS 413: UG HPS Colonial 4-Sided 9500L	73	81	8	84	3	86	2
LGUM_416 LS 416: UG HPS Acorn 9500L Decorative	3	3	0	3	0	3	0
LGUM_420 LS 420: UG HPS Contemporary 16000L Deco	6	6	0	6	0	11	5
LGUM_421 LS 421: UG HPS Contemporary 28500L Deco	5	5	0	5	0	6	1
LGUM_422 LS 422: UG HPS Contemporary 50000L Deco	7	7	0	7	0	7	0
LGUM_423 LS 423: UG HPS Cobra Head 16000L Deco	11	11	0	14	3	16	2
LGUM_424 LS 424: UG HPS Cobra Head 28500L Deco	572	635	63	650	15	670	20
LGUM_425 LS 425: UG HPS Cobra Head 50000L Deco	6	7	1	7	0	9	2
LGUM_427 LS 427: UG HPS London 5800L Historic	2	2	0	2	0	2	0
LGUM_430 RLS 430: UG HPS Victorian 5800L Deco	12	12	0	12	0	12	0
LGUM_433 LS 433: UG HPS Victorian 9500L Historic	3	3	0	3	0	3	0
LGUM_445 LS 445: UG HPS Acorn 16000L Decorative	0	0	0	15	15	15	0
LGUM_452 LS 452: OH HPS Cobra Head 16000L Fixture	3530	3619	89	3690	71	3733	43
LGUM_453 LS 453: OH HPS Cobra Head 28500L Fixture	8006	8300	294	8488	188	8595	107
LGUM_454 LS 454: OH HPS Cobra Head 50000L Fixture	2148	2065	-83	2018	-47	1993	-25
LGUM_455 LS 455: OH HPS Directional 16000L Fix	3	4	1	6	2	7	1
LGUM_456 LS 456: OH HPS Directional 50000L Fix	288	285	-3	295	10	298	3
LGUM_457 LS 457: OH HPS Open Bottom 9500L Fixture	22	23	1	23	0	23	0
LGUM_473 LS 473: OH MH Directional 32000L Fixture	0	2	2	2	0	2	0
LGUM_490 LS 490: OH LED Cobra Head 8179L Fixture	0	0	0	0	0	5	5
LGUM_491 LS 491: OH LED Cobra Head 14166L Fixture	0	0	0	0	0	7	7
LGUM_493 LS 493: OH LED Open Bottom 5007L Fixture	0	0	0	0	0	44	44

LOUISVILLE GAS AND ELECTRIC COMPANY

**Response to First Request for Information of the
Louisville/Jefferson County Metro Government
Dated November 13, 2018**

Case No. 2018-00295

Question No. 21

Responding Witness: John K. Wolfe

- Q-21. For each of the past three years, please provide the number of street lights that LG&E had planned on replacing prior to that year, and a summary of the actual number replaced that year for the following: Louisville Metro (extrapolate if needed) and LG&E's entire system.
- A-21. LG&E had no planned replacements of street lights for each of the past three years. LG&E replaces street lights at the request of customers, or when dictated by failure, damage, or unsatisfactory physical condition.

LG&E does not track replacements by customers. LG&E replaced fixtures in the approximate amounts indicated below.

	2015	2016	2017
LG&E	3,860	3,251	3,229

LOUISVILLE GAS AND ELECTRIC COMPANY

**Response to First Request for Information of the
Louisville/Jefferson County Metro Government
Dated November 13, 2018**

Case No. 2018-00295

Question No. 22

Responding Witness: John K. Wolfe

- Q-22. Please explain in detail LG&E's current policies, procedures, practices, and/or guidelines for maintaining street lights in Jefferson County and provide copies of the same.
- a. Does LG&E regularly inspect individual street lights or the collective street lighting in the Louisville Metro boundaries?
 - b. Do these inspections take place only upon the receipt by LG&E of a complaint regarding a particular street light?
 - c. What is the average response time to replace a non-working street light in Jefferson County?
 - d. Does this information differ depending upon the type of street light? If so, please provide a detailed explanation.
- A-22. LG&E maintains its street lights and other lighting products consistent with the original LG&E installation standards, the Terms and Conditions of the Lighting Service and Restricted Lighting Service Schedules, and in compliance with 807 KAR 5:041. Electric: Section 2 – General Requirements, Section 3 – Acceptable Standards, and Section 5 – Maintenance or Continuity of Service. A copy of these installation standards is attached
- a. LG&E conducts proactive lighting patrols as part of its normal operations. These night-time patrols are integrated into LG&E's normally scheduled operations for outage response activities. When not responding to outages, LG&E's outage technicians, who are on duty 24 hours a day, 7 days a week, undertake lighting patrol and maintenance activities, among other duties that they perform daily.
 - b. LG&E also issues repair orders in response to light outages reported by KU employees and contractors, customers, LFUCG personnel, police, fire departments, and the general public. Outages can be reported via:

1. Website: <https://lge-ku.com/customer-service/report-streetlight-outage>
 2. Residential Call Center: 1-800-331-7370
 3. Metro311
- c. LG&E does not track average response time to replace a non-working light by county. KU has a long-standing practice of tracking lighting repair activity reported by LexCall 311 in Lexington-Fayette County that is not replicated by KU or LG&E anywhere else in the service territories. See the response to Question No. 25 below for LG&E-wide data on average response time.
- d. No.

Electric System
 Codes & Standards

MAST ARM INSTALLATION FOR COBRA AND OPEN BOTTOMS 80 06 20
ON WOOD POLES
Rev. C

ASSEMBLY DESCRIPTION
 80 06 20 . XX

ASSEMBLY DETAILING 2', 6', AND 10'
 MAST ARM INSTALLATION ON WOOD POLES.
 80 06 20. 01 LUMINAIRE ASSEMBLY ON 2' MAST ARM
 80 06 20. 02 LUMINAIRE ASSEMBLY ON 6' MAST ARM
 80 06 20. 03 LUMINAIRE ASSEMBLY ON 10' MAST ARM

NOTE:

1. SECONDARIES SHOWN FOR EXAMPLE PURPOSE ONLY. ACTUAL CONNECTIONS MAY BE 120V OR 240V DEPENDING ON JOB REQUIREMENTS.
2. REFER TO 021012 FOR PROPER SPACING REQUIREMENTS.

MATERIAL LIST

ITEM	QTY	DESCRIPTION	01	02	03
1	VARIABLES	MAST ARM, ALUM - SEE STD 800202	1	1	1
2	VARIABLES	LAMP/LUMINAIRE - SEE STD 800000	1	1	1
3	VARIABLES	5/8" MACHINE BOLT W/NUT	1	1	1
4	1159243	SCREW, LAG, 1/2" X 4", GIMLET POINT GALV	2	2	4
5	7001357 OR	CABLE, 600V, #12 SOLID 2/C W/GROUND, TYPE UF-B, OH & UG			
	7000414	CABLE, OH DUPLEX, #4 AL W/#4 ACSR NEUTRAL, XLP, TERRIER, 500' COIL			
6	VARIABLES	VARIOUS SMALL CONNECTORS	4	4	4
7	7000913	MOULDING, GROUND 1/2" X 8F. PLASTIC			
8	7000337	WASHER, FLAT, SQUARE, 2-1/4" X 2-1/4" X 3/16" FOR 5/8" BOLT, GALV STL	1	1	1
9	7005817	CONDUCTOR, OH WIRE, 4 CU BARE, SD SOLID			

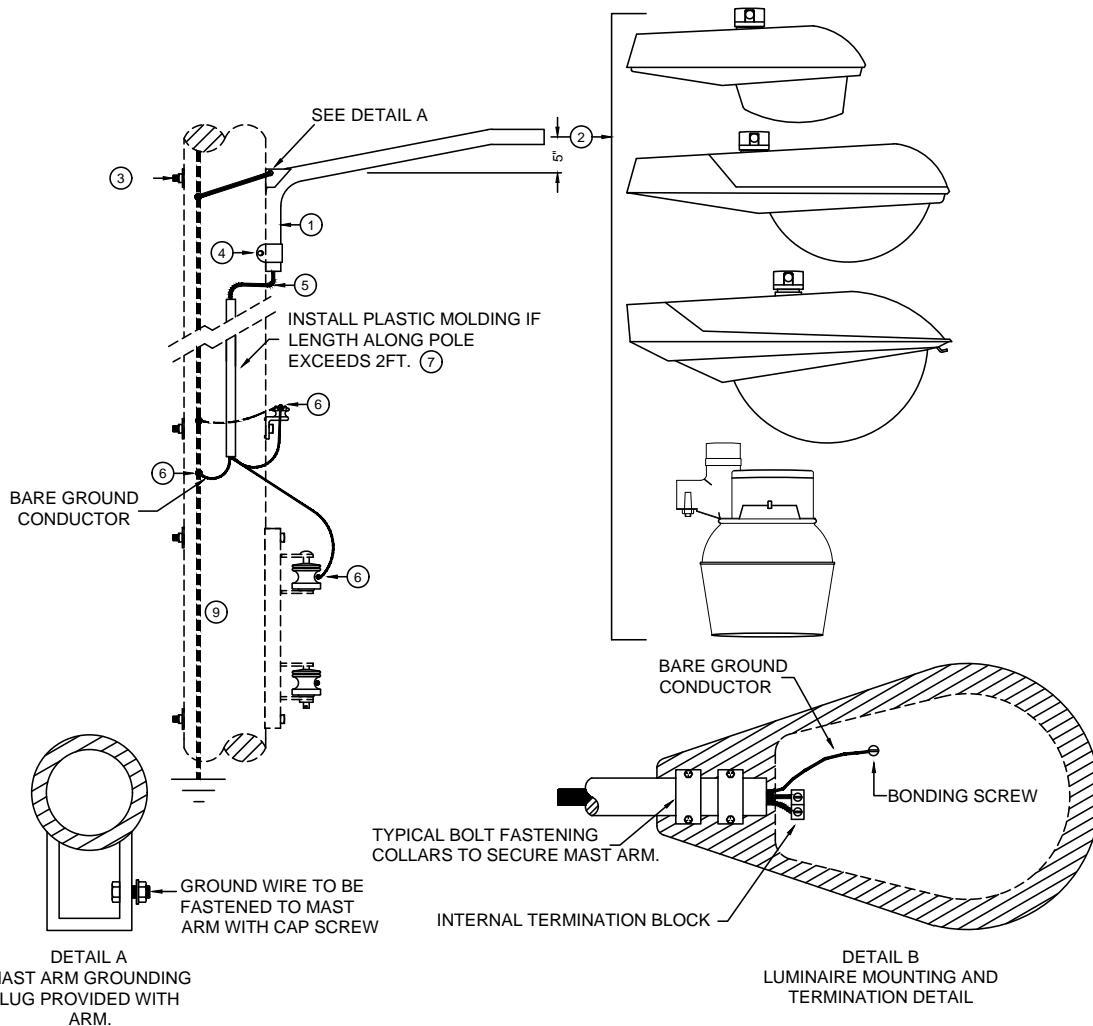

Electric System
 Codes & Standards

YARD TYPE / PACKAGE LIGHT WOOD POLE INSTALLATION

80 06 22
 Rev. A

Grounding notes:

All existing and new fixtures and mast arms must be grounded unless grounding negatively impacts safety or the reliability of the structure. Grounding of both the fixture and the mast arm can be accomplished by grounding either the fixture, the mast arm or both. In general a visible external ground is preferred.

Internal grounding can be accomplished by attaching a separate ground wire of a 3-wire cable (i.e. 12-2/C w/ground) between the pole ground and ground lug in the fixture.

For external grounding, the pole ground wire is fastened to mast arm with 3/8" x 1-1/4" carriage bolt, nut and lock washer (IIN #3003808) using a minimum of #6 bare SD Cu. Older installations with no grounding provisions can be grounded by drilling the support and using a self tapping screw and washer.

MATERIAL LIST

ITEM	IIN NUMB.	DESCRIPTION	QTY.
1	VARIES	SEE STANDARD 800000 FOR LAMP	1
2	7000258	BOLT, MACHINE, SQ HD, 5/8" X 10", GALV. W/SQ NUT	1
3	7000911	BRACKET, WIRE, 1-INSULATOR, LESS INSULATOR, 4" X 3-1/4"	1
4	7001268	INSULATOR, SECONDARY, SPOOL 3", PORCELAIN OR POLYETHYLENE	1
5	7002215	CLAMP, WEDGE, SERVICE, #2- #6 ACSR, RIGID SS BAIL	*
6	7000339	WASHER, CURVED, SQUARE, 3" X 3" X 1/4", GALV. FOR 5/8" BOLT	1
7	VARIES	VARIOUS SMALL CONNECTOR	*
8	7000913	MOULDING, GROUND, 1/2" X 8F, PLASTIC	*
9	7001357 OR	CABLE, 600V, #12, SOLID, 2/C W/GROUND, TYPE UF-B, OH & UG	*
	7000414	CABLE, OH, DUPLEX, #4 AL W/#4 ACSR NEUTRAL, XLP, TERRIER, 500' COIL	*
10	7005817	CONDUCTOR, OH WIRE, 4, CU, BARE, SD, SOLID, 25 LB. SPOOL	*
11	7002252	STAPLE, MOULDING, ROLLED POINT, FOR 1/2" MOULDING, STL	*

* AS REQUIRED

NOTES:

① Package light kit includes, head, optics, lamp, photo control, 2/wire - pre-wired cable, mast arm, 5/8" mounting bolt & lag screws and grounding bolt. *LED FIXTURES CAN BE USED WITHOUT REFRACTOR.

② Install cable guard 1/2", ground wire moulding (IIN 7000913) if length along pole exceeds 2 ft. Vertical riser must be covered with cable guard even if jacketed conductor cable is used. If 3-#6al. poly is used you may use 1" x 10' cable guard U shaped PVC IIN # 1160501.

③ Pole and pole grounding not included in this standard.

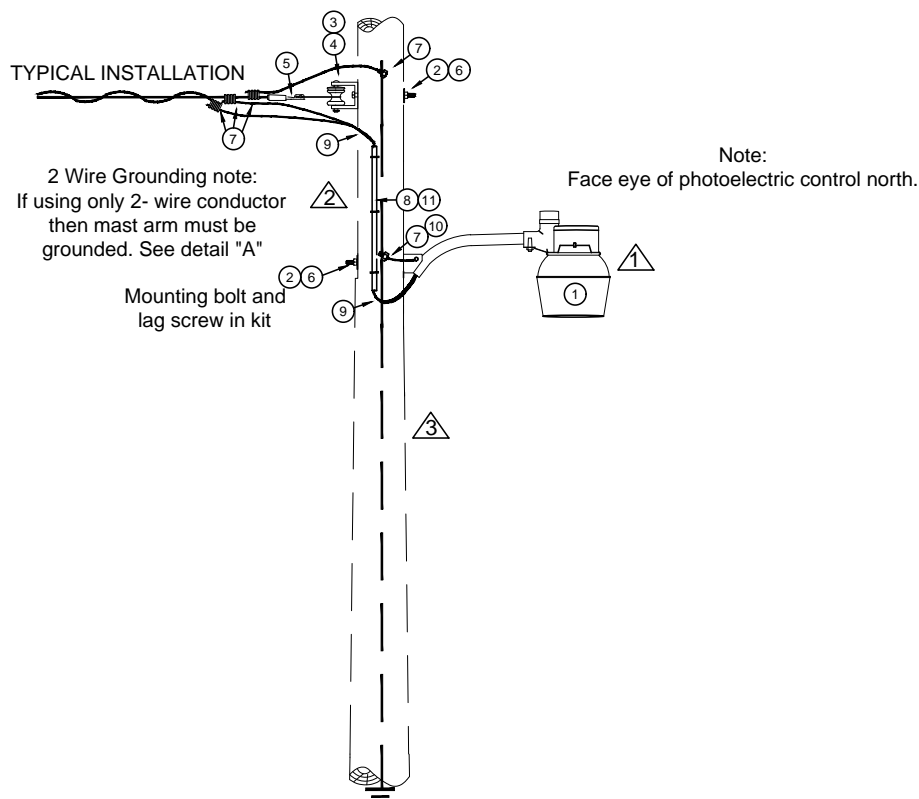

Electric System
 Codes & Standards

STREET LIGHT CONSTRUCTION ANCHOR BASE - OVERHEAD COBRA HEAD **80 06 24**
Rev.

NOTE:
 POLE WITH OH
 SERVICE - NOT
 CONSIDERED
 BREAKAWAY

MATERIAL LIST

ITEM	FIN	DESCRIPTION	QTY
1	VARIABLES	LAMP - SEE STD 800000	1
2	VARIABLES	POLE - SEE STD 800002	1
3	7000414	CABLE OH DUPLX #4 AL W/#4 ACSR NEUTRAL XLP TERRIER 500' COIL	1
4	7000836	BAND, POLE 4 WAY SMALL GALV STL	1
5	7000911	BRACKET WIRE, 1-INSULATOR, LESS INSULATOR, 4" X 3-1/4"	1
6	7001268	INSULATOR, SECONDARY, SPOOL 3"	1
7	7005817	CONDUCTOR OH WIRE 4 CU BARE SD SOLID 25 LB SPOOL	1
8	7000888	ROD GROUND, 5/8" X 8' BONDED COPPER	1
9	7000887	CLAMP GROUND ROD 5/8" 8-1/2' HEX CU HEAVY DUTY	1

* AS REQUIRED

SEE 80 08 04
 FOR KY DOT
 COMPLIANT FOUNDATION

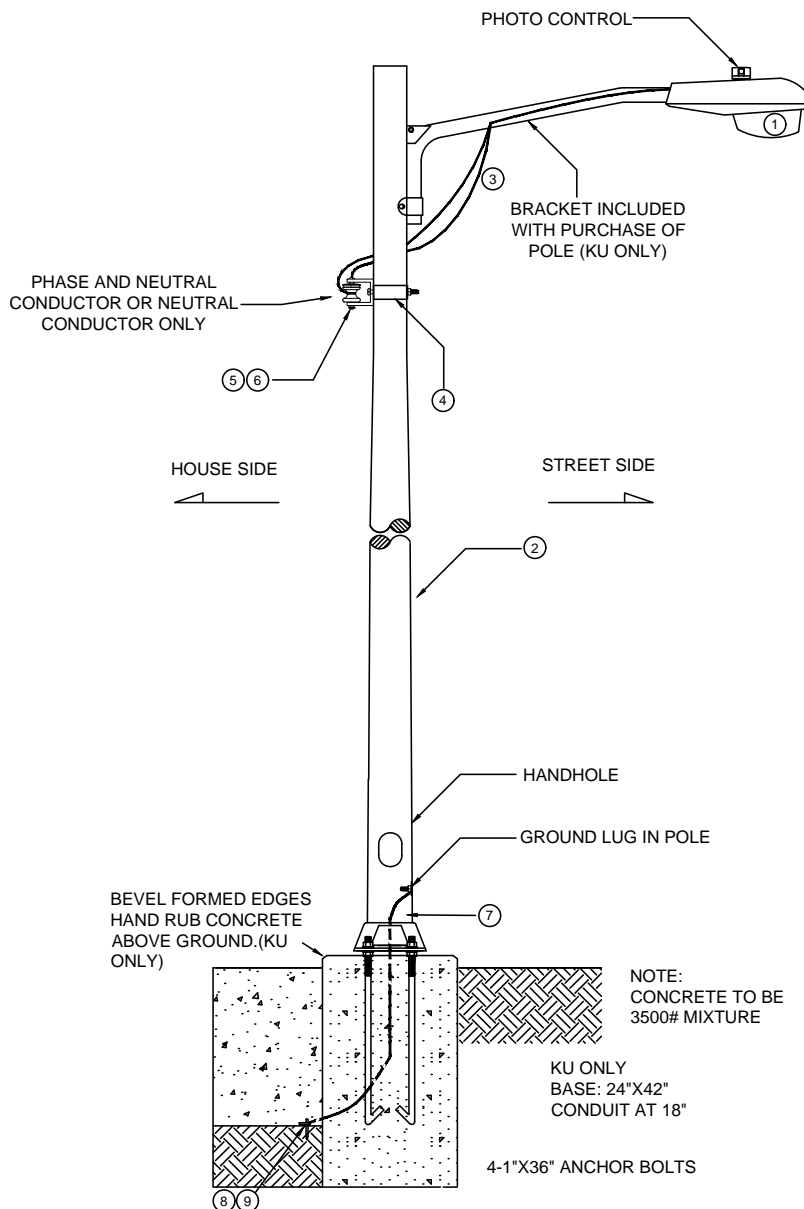

Electric System
 Codes & Standards

POLES USED WITH POST TOP MOUNT LUMINAIRES

80 08 20
Rev. C

NOTE:

1. PROPER LAMP/LUMINAIRE COMBINATION AND ASSOCIATED EQUIPMENT MUST BE ADDED TO MATERIAL LIST. SEE STANDARD 800000.
2. NEUTRAL CONNECTION IS MADE WITH SPLIT BOLT CONNECTOR ONLY - NO TAPING IS REQUIRED.
3. SEE OPPOSITE PAGE FOR FOUNDATION DETAIL.
4. SPLICING MATERIAL IS INCLUDED IN THIS STANDARD IF NOT NEEDED OMIT FROM MATERIAL LIST.
5. SEE 800002 FOR SETTING OR EMBED DEPTH.

MATERIAL LIST

ITEM	QTY	DESCRIPTION	QTY
1	VARIES	POLE - SEE STD. 800002	1
2	7001357 OR 7000414	CABLE, 600V, #12, SOLID, 2/C W/GROUND, TYPE UF-B, OH & UG CABLE, OH, DUPLEX, #4 AL W/#4 ACSR NEUTRAL, XLP, TERRIER	20
3	VARIES	CONNECTOR, SPLIT BOLT	2
4	1164401	TAPE, ELECTRICAL, VINYL, 3/4" X 8.5 MIL X 66', BLACK, ALL WEATHER	1
5	1164435	TAPE, NON FUSING RUBBER, 3/4" X 30 MIL X 30', EPR	1
6	7000674 OR 7006682	CONDUIT, PVC, 1" X 10', SCH 40, LONG BELL END CONDUIT, PVC, 2" X 20', SCH 40, LONG BELL END	*
7	7010086 OR 7001206	ELBOW, CONDUIT, PVC, 1" X STD (5-3/4"), SCH 40, 90 DEG, DEEP SOCKET ELBOW, CONDUIT, PVC, 2" X 24", SCH 40, 90 DEG, DEEP SOCKET	1
8	7000888	ROD, GROUND, 5/8" X 8", BONDED COPPER	1
9	7000887	CLAMP, GROUND ROD, 5/8", 8-1/0, HEX, CU, HEAVY DUTY	1

* AS REQUIRED

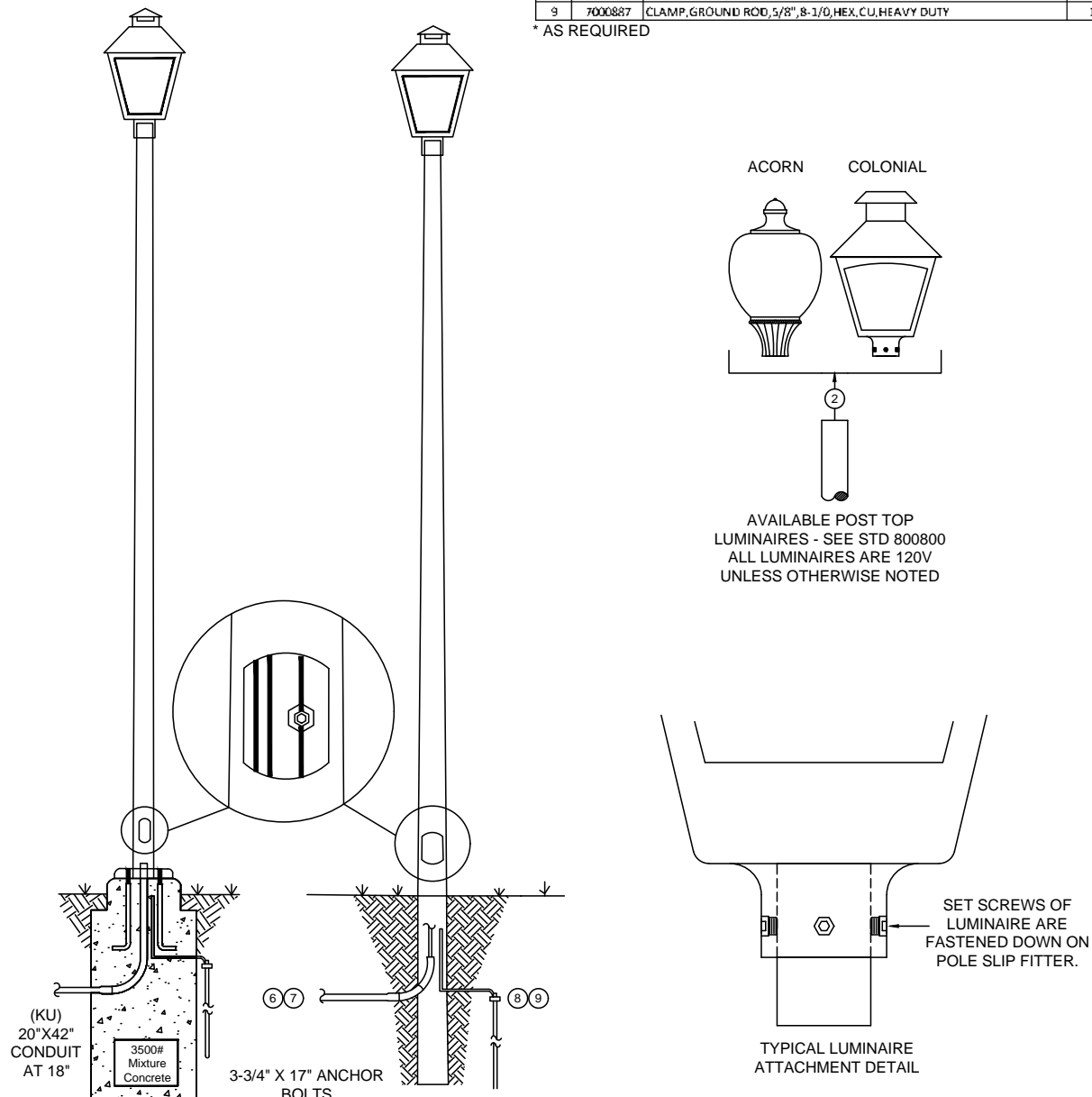

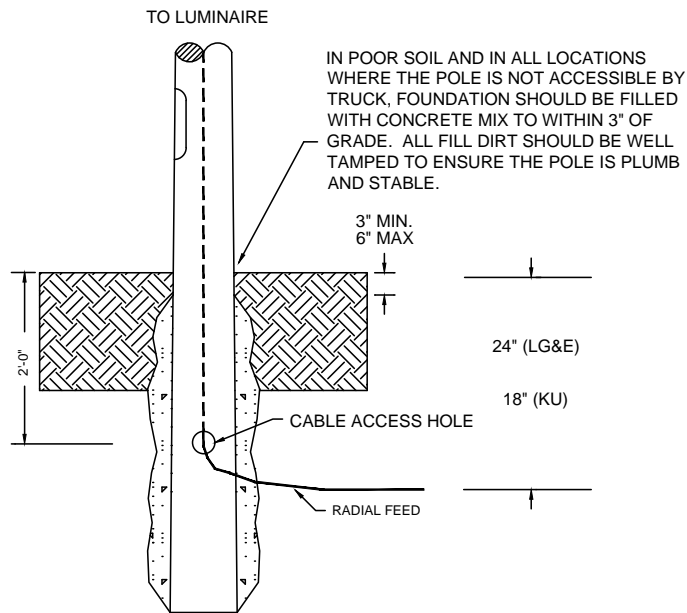

FOUNDATION DETAIL FOR POOR SOIL
 OR NON BUCKET TRUCK ACCESSIBLE
 LOCATIONS

Electric System
 Codes & Standards

**INSTALLATION OF DIRECT BURIED ALUMINUM POLES WITH
 MAST ARMS - UNDERGROUND SERVICE**

80 08 21
 Rev. E

NOTE:

1. PROPER LAMP/LUMINAIRE COMBINATION AND ASSOCIATED EQUIPMENT MUST BE ADDED TO MATERIAL LIST. SEE STANDARD 80 00 00.
2. SEE OPPOSITE PAGE FOR FOUNDATION AND ARM MOUNTING DETAILS.
3. SPLICING MATERIAL IS INCLUDED IN THIS STANDARD. IF NOT NEED OMIT FROM MATERIAL LIST.
4. MAKE SURE THAT BARE GROUND CONDUCTOR IS BONDED TO THE GROUND STUD OF EACH LUMINAIRE HEAD.

MATERIAL LIST

ITEM	UN	DESCRIPTION	QTY
1	VARIES	POLE - SEE STD 80 00 02	1
2	7001357	CABLE 600V #12 SOLID 2/C W/GROUND	40
3	VARIES	SPLIT BOLT CONNECTOR	3
4	1164401	TAPE, ELECTRICAL VINYL, 3/4" X 8 5 MIL X 66' BLACK	1
5	1164435	TAPE, NON FUSING RUBBER 3/4" X 30 MIL X 30' EPR	1
6	VARIES	ARM/MAST - SEE STD 80 02 02	1
7	7010086 OR 7001206	ELBOW CONDUIT PVC, 1" X STD (5-3/4")	1
8	7000674 OR 7000682	CONDUIT PVC, 1" X 10', SCH 40, LONG BELL END	1
9	7000888	ROD, GROUND 5/8" X 8', BONDED COPPER	1
10	7000887	CLAMP, GROUND ROD, 5/8" - 8-1/2" HEX, CU HEAVY DUTY	1

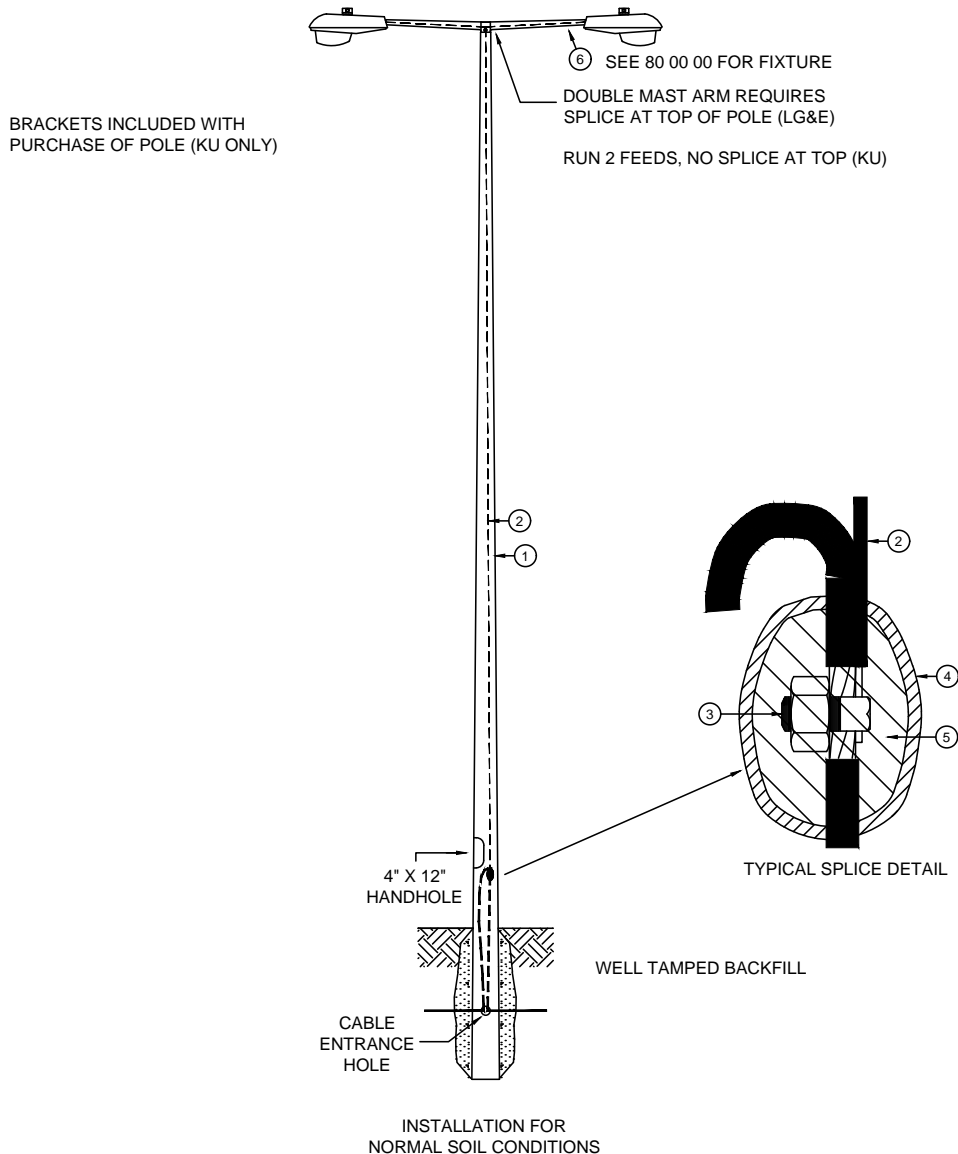

Electric System
 Codes & Standards

INSTALLATION OF DIRECT BURIED ALUMINUM POLES WITH
 MAST ARMS - UNDERGROUND SERVICE

80 08 21
 Rev. E

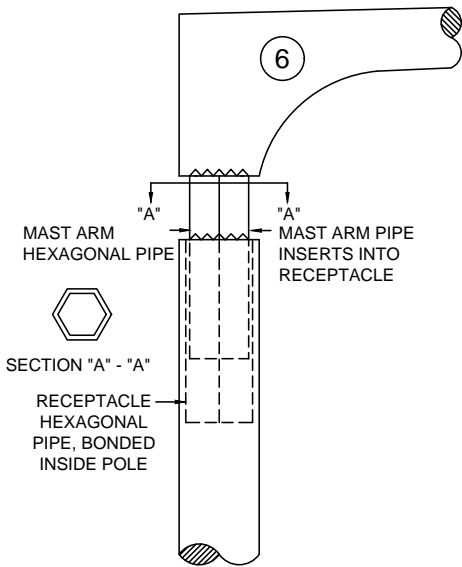

DETAIL "A" SINGLE ARM
 ATTACHMENT 80 08 21 . XX 01

HARDWARE FOR ARM MOUNTING INCLUDED WITH ARM. HOLES FOR BOLTS ARE PREDRILLED IN POLE.

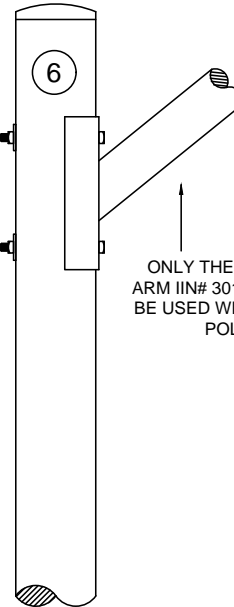

DETAIL "B" ARM
 ATTACHMENT FOR 28' MTH
 BLACK POLE 80 08 21 . 01 01
 ONLY

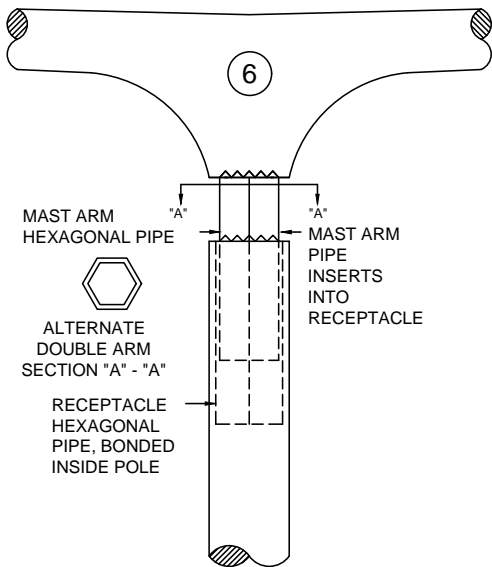

80 08 21 . XX 02
 DOUBLE ARM ATTACHMENT

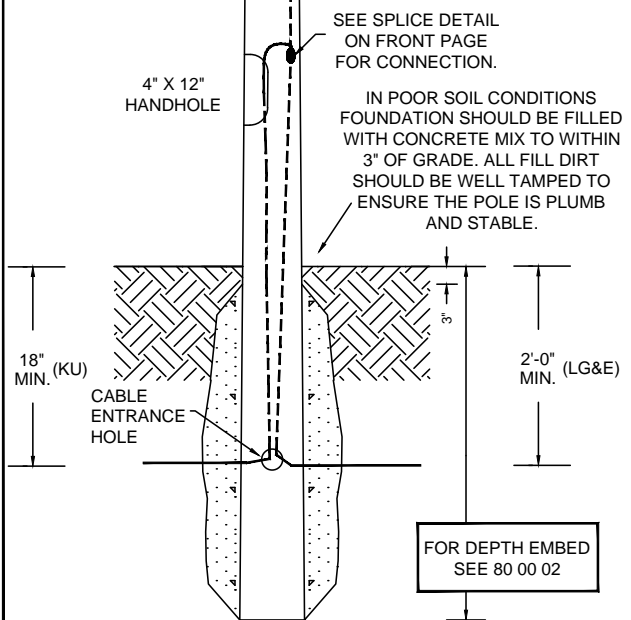

FOUNDATION DETAIL FOR
 POOR SOIL CONDITIONS

Electric System
 Codes & Standards

GENERAL REQUIREMENTS FOR WIRING AND GROUNDING
 SINGLE PHASE UNDERGROUND FED STREET LIGHT POLES

80 08 25
 Rev. A

NOTES

- Conductor:** Underground street light feeds can be 2-wire (duplex) or 3-wire (Typically #12-2/C with ground UF-B cable). Conductor size is dependent on circuit loading and length. All new installations to be installed in conduit.
- Over-current Protection:** All underground fed lights are to have over-current protection installed at the source. Protection should be sized for the smallest conductor on the circuit or smaller taps must be separately fused.
 - Overhead -Underground Street Light Feeds: Fuses or ground mounted breaker boxes are to be installed for all overhead to underground street light feeds.
 - Underground Street Light Feeds: Fuse protection is to be installed at the source (padmount transformer, splice box or pedestal) for all underground street light feeds.
- Both the neutral and grounding conductors of 3-wire feeds are to be terminated on the neutral bushing of padmount transformers or the neutral connection inside splice boxes and pedestals.

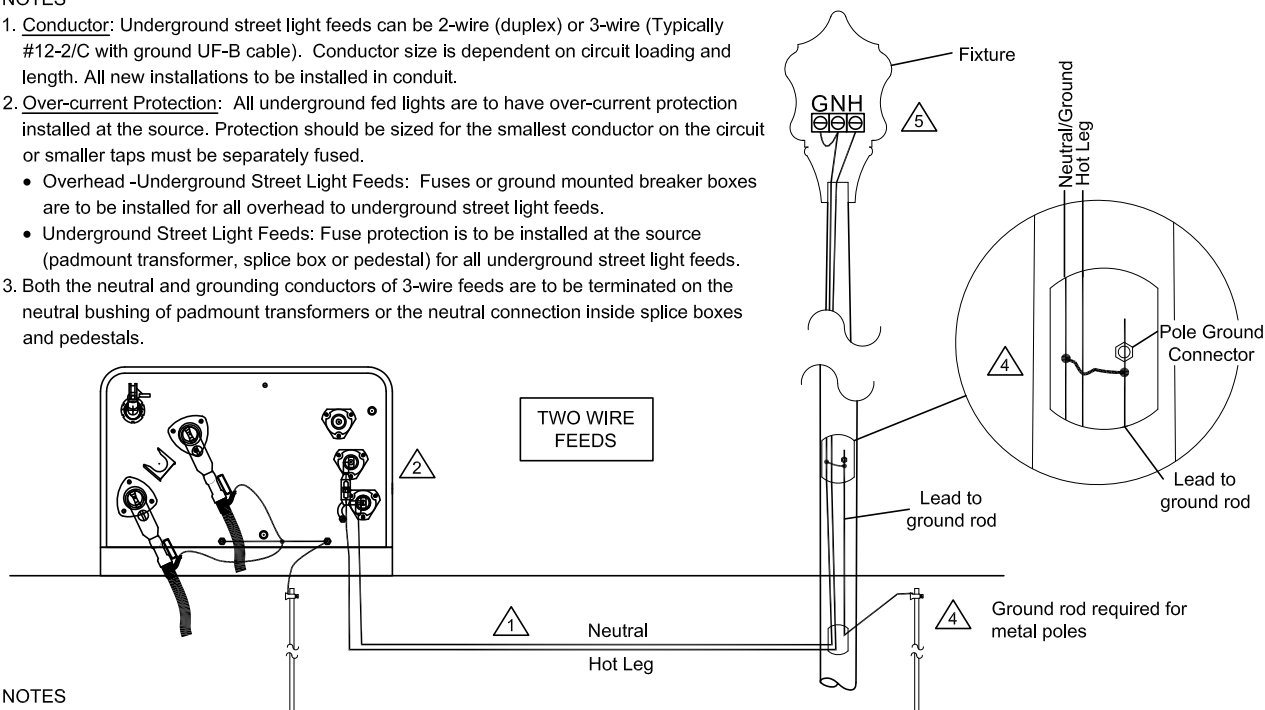

NOTES

- Pole Grounding:** Non-metallic poles do not require a ground rod unless there are accessible exposed metal parts that can become energized. All metal lighting poles are to have a separate ground rod installed and bonded as follows:
 - 2-Wire Feed: Ground rod is to be bonded to the pole and neutral conductor in the handhole.
 - 3-Wire Feed: Ground rod is to be bonded to the pole and grounding conductor in the handhole.
- Fixture Connections**
 - 2-Wire Feeds: Ground and neutral lugs to be bonded together in fixture.
 - 3-Wire Feeds: Ground and neutral wires to be terminated on separate lugs in fixture.
- When a breaker box is used for protection of overhead to underground lighting feeds, breaker box must be grounded and grounding conductor must be bonded to pole ground at top of riser.

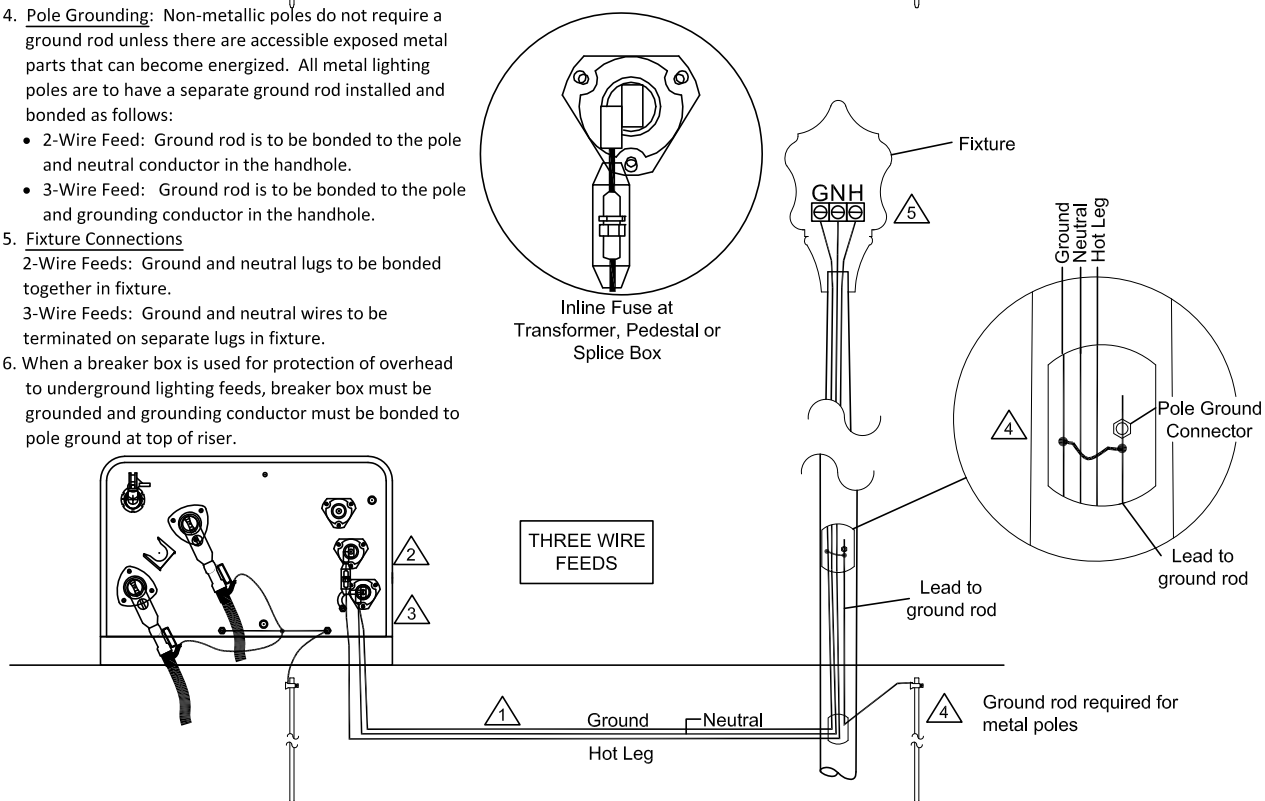

Electric System
 Codes & Standards

**GENERAL REQUIREMENTS FOR WIRING AND GROUNDING
 SINGLE PHASE UNDERGROUND FED STREET LIGHT POLES**

80 08 25
 Rev. A

Fuse Holders

Item	Description	Loadside	Lineside
1177051	FUSEHOLDER, IN LINE, #12 CU TO #3 CU, WATER RESISTANT, 30A, 600V	#12 CU to #3 CU	#12 CU to #3 CU
3012977	FUSEHOLDER, IN LINE, BREAKAWAY, #12 CU TO #8 CU LOAD & #12 AL TO #2 AL- LINE, WATERRESISTANT, 30A, 600V	#12 CU to #8 CU	#12 AL to #2 AL
7010720	FUSEHOLDER, IN LINE, #12 AL TO #2 AL, WATER RESISTANT, 30A, 600V	#12 AL to #2 AL	#12 AL to #2 AL
7003835	FUSEHOLDER, IN LINE, BREAKAWAY, #12 AL TO #2 AL, WATER RESISTANT, 30A, 600V	#12 AL to #2 AL	#12 AL to #2 AL



Fuse Holder Cover

3000397	COVER, SPLICE, SUBMERSIBLE, #14-350, 4-7/16" L	WATER TIGHT	
1177060	BOOT, INSULATING, FOR TRON FUSE HOLDER, TYPE-L	OBSOLETE USE IIN # 3000397	
7010721	BOOT, INSULATING, FOR IN-LINE FUSEHOLDER		



Fuses

7010724	FUSE, CARTRIDGE, 30A, KTK, 13/32" X 1-1/2" 600V, STREETLIGHTS
1160486	FUSE, CARTRIDGE, 20A, KTK, 13/32" X 1-1/2" 600V, STREETLIGHTS
7000708	FUSE, SECONDARY, TUBULAR FLAG, 120/240V, 30A (overhead)
7000709	FUSE, SECONDARY, TUBULAR FLAG, 120/240V, 15A (overhead)
3013202	BLANK FUSE TO BE USE IN BREAKAWAY FUSEHOLDER-NEUTRAL



Breakers

0530719	BREAKER, CIRCUIT, 20 AMP, 1-POLE, SNAP-IN (BREAKER BOX IIN 0530694)
0530735	BREAKER, CIRCUIT, 70 AMP, 1-POLE, SNAP-IN (BREAKER BOX IIN 0530694)



Breaker Boxes

0530701	BOX, BREAKER, KIT, 100A, 120/240V, 2 POSITION WITH/WEATHERPROOF BOX, 2" HUB & 2" PVC WEATHERHEAD AND HARDWARE
0530694	BOX, BREAKER, KIT, 70A, 120/240V, 2 POSITION WITH/WEATHERPROOF BOX, 1" HUB, & 1" PVC WEATHERHEAD AND HARDWARE
0461978	BOX, BREAKER, STEEL, NEMR 3R RATED, 8.88" x 4.88" x 18", USE WITH FAL, FHL & FCL CIRCUIT BREAKERS (15A TO 100A), FOR 480V URD APPLICATION WITH NEUTRAL PROVISION



Electric System
 Codes & Standards

SPECIAL KY DOT COMPLIANT FOUNDATION FOR BREAKAWAY POLES UP TO 35' WITH MAXIMUM 15' ARM **80 08 40**
 Rev.

Notes \triangle

1. Precast foundations are not allowed.
2. Ground rod and #4 copper or copper weld ground wire installed by contractor with foundation. A minimum of 24" of ground wire to be exposed above top of conduit.
3. Foundation depth and below ground dimensions are minimums. Where rock is encountered, foundation requires a minimum 2'-0" rock embedment not to exceed an overall depth of 5'-0". Minimum foundation depth with 2'-0" rock embedment is 3'-6" (for anchor bolts).
4. Foundation to extend above ground approximately 1" with chamfered edge. Top of foundation to be finished smooth and level with rebar and anchor bolts perpendicular to top of foundation. 3" minimum to be provided between rebar and any edge of foundation
5. Concrete mix to be a minimum 3,500 PSI strength and a 4" to 6" slump and placed in a dry hole.
6. Foundation to be oriented for light positioned between anchor bolts
7. Foundation designed to meet AASHTO 2009 requirements and is acceptable for most soil conditions.
8. Conduit to be Schedule 40 minimum with number, size and orientation to be specified by utility.
9. Bolt pattern shown is for 10 1/2" diameter bolt circle. For poles with larger diameter bolt circles installer may adjust as necessary.

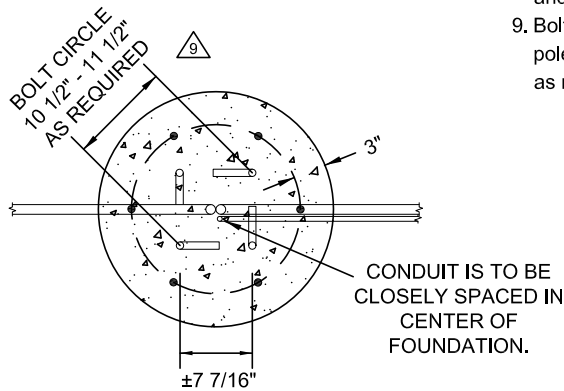

FOUNDATION DETAIL

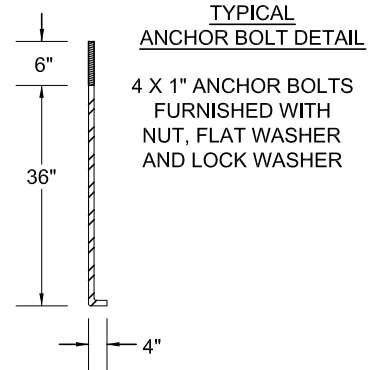

TYPICAL ANCHOR BOLT DETAIL

4 X 1" ANCHOR BOLTS FURNISHED WITH NUT, FLAT WASHER AND LOCK WASHER

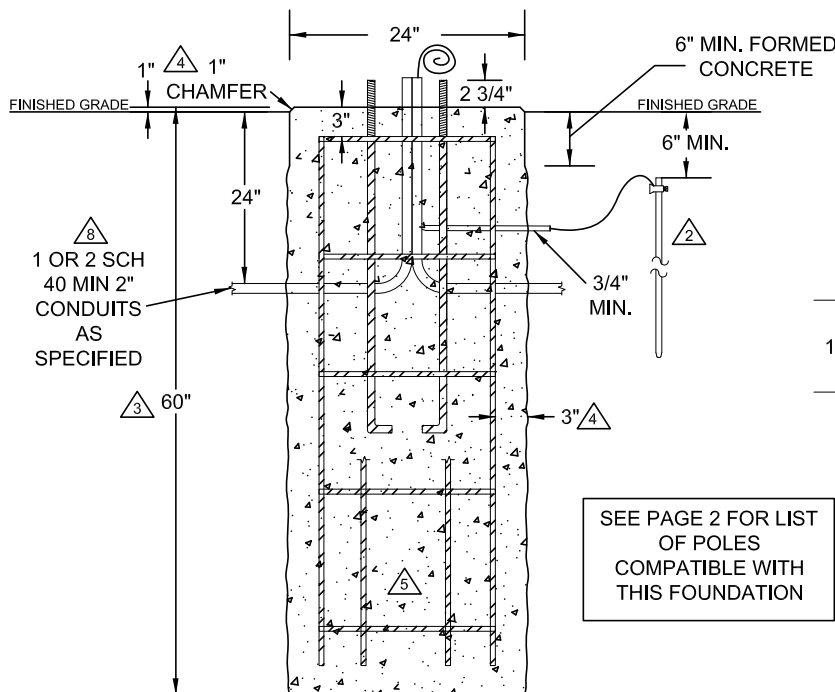

REBAR CAGE DETAIL

6 #5 VERTICAL BARS EQUALLY SPACED
 #3 BAR TIES 12" ON CENTER OR SPACED AT 12" PITCH

Electric System
Codes & Standards

SPECIAL KY DOT COMPLIANT FOUNDATION FOR BREAKAWAY POLES UP TO 35' WITH MAXIMUM 15' ARM

80 08 40
Rev.

Aluminum BREAKAWAY Poles That Fit KYDOT Foundation

Note: Only breakaway poles allowed in KYDOT controlled areas.

IIN	DESCRIPTION	MOUNTING HEIGHT	ARM	BOLT CIRCLE
7010305	POLE,ALUM,30F MH,ORN,4 BOLT,TWIN 6F,W/ANC BOLTS	30'	TWIN 6' ARMS	11"-12"
7010301	POLE,ALUM,30F MH,ORN,4 BOLT,TRUSS 15F,W/ANC BOLTS	30'	15' ARM	10"-11"
7010298	POLE,ALUM,30F MH,ORN,4 BOLT,TRUSS 12F,W/ANC BOLTS	30	12' ARM	10"-11"
7003754	POLE,ALUM,25F MH,ORN,4 BOLT,TWIN 6F,W/ANC BOLTS	25'	TWIN 6' ARMS	10"-11"
7003222	POLE,ALUM,30F MH,ORN,4 BOLT,TWIN 10F,W/ANC BOLTS	25'	TWIN 10' ARMS	11"-12"
7003218	POLE,ALUM,25F MH,ORN,4 BOLT,SINGLE 4F,W/ANC BOLTS	25'	4' ARM	10"-11"
7001420	POLE,ALUM,25F MH,ORN,4 BOLT,SINGLE 6F,W/ANC BOLTS	25'	6' ARM	10"-11"
7001419	POLE,ALUM,25F MH,ORN,4 BOLT,TRUSS 10F,W/ANC BOLTS	25'	10' ARM	10"-11"
7001418	POLE,ALUM,30F MH,ORN,4 BOLT,SINGLE 6F,W/ANC BOLTS	30	6' ARM	10"-11"
7001417	POLE,ALUM,30F MH,ORN,4 BOLT,TRUSS 10F,W/ANC BOLTS	30'	10' ARM	10"-11"
7001416	POLE,ALUM 30F MH,ORN,4 BOLT,SINGLE 8F,W/ANC BOLTS	30'	8' ARM	10"-11"
3008584	POLE,ALUMINUM,30' MH,WITH BREAKAWAY BASE FLANGE,CONTEMPORARY LT, PAINTED STANDARD BLACK POWDER COAT FINISH	30'	N/A	10"-11"
3008583	POLE,ALUMINUM,35' MH,WITH BREAKAWAY BASE FLANGE, 8" x .156",BLACK,CONTEMPORARY (JUST FOR UK)	35'	N/A	11"-12"

Electric System
 Codes & Standards

**STREET LIGHT CONSTRUCTION ANCHOR BASE -
 UNDERGROUND COBRA HEAD**

80 08 44
 Rev.

NOTE: FOR BREAKAWAY
 CONSTRUCTION, ANCHOR BASE
 DEPTH MUST BE INCREASED SO
 THAT THE ANCHOR BOLTS DO NOT
 EXCEED 4" ABOVE GRADE.

MATERIAL LIST

ITEM	UIN	DESCRIPTION	QTY
1	VARIABLES	LAMP - SEE STD 800000	1
2	VARIABLES	POLE - SEE STD 800002	1
3	7006487 OR	CABLE 600V, #12, SOLID, 2/C W/GROUND, TYPE UF-B, OH & UG	*
4	7003674 OR	CONDUIT, PVC, 1" X 10' SCH 40, LONG BELL END GREY	1
4	7006682	CONDUIT, PVC, 2" X 20' SCH 40, LONG BELL END GREY	1
5	7010086 OR	ELBOW CONDUIT, PVC, 1" X STD 1/2-3/4", SCH 40, 90 DEG DEEP SOCKET	1
5	7001206	ELBOW CONDUIT, PVC, 2" X 24" SCH 40, 90 DEG DEEP SOCKET, GREY	1
6	7000888	ROD GROUND, 5/8" X 8', BONDED COPPER	1
7	7000887	CLAMP, GROUND ROD 5/8" 3-1/2, HEX CU, HEAVY DUTY	1
8	7005817	CONDUCTOR OH WIRE 4 CU BARE SD, SOLID, 25 LB. SPOOL	*
9	7000420	CONNECTOR COMPRESSION, TAP, AL, 4-2:4-2A, 6-4:1 STR	2

* AS REQUIRED

SEE 80 08 04
 FOR KY DOT
 COMPLIANT FOUNDATION

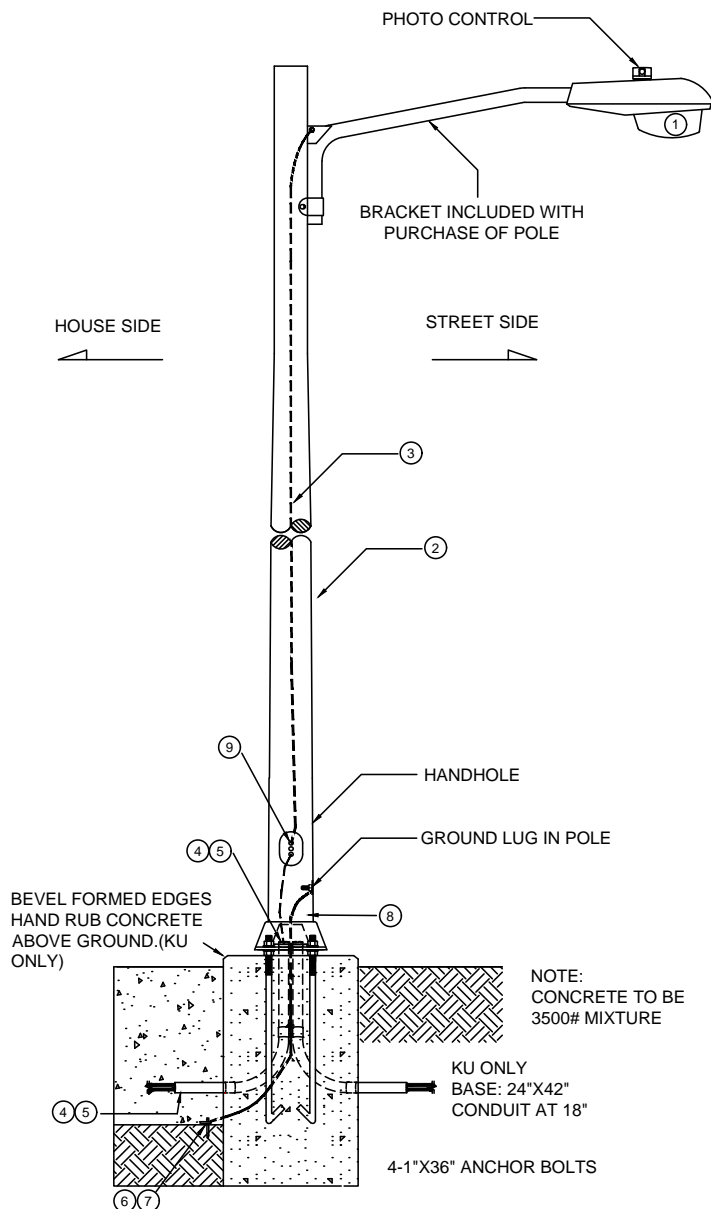

ASSEMBLY DESCRIPTION
80 08 23

THIS ASSEMBLY INCLUDES:

A BRONZE DECASHIELD III LUMINAIRE 120V, 150W HPS WITH 16' MTH ON A 20' - 4" X 4" DARK BRONZE FIBERGLASS POLE (STRAIGHT SQUARE POLE, DIRECT BURIAL).

THIS 20' X 4" X 4" FIBERGLASS POLE AND THIS DECASHIELD III LUMINAIRE ARE TO BE USED IN THIS COMBINATION ONLY AND NO OTHER.

FACE EYE OF PHOTOELECTRIC CONTROL NORTH.

MATERIAL LIST

ITEM	IIN NUMB.	DESCRIPTION	QTY
1	0483978	POLE, 20' FIBERGLASS 4" X 4" DARK BRONZE	1
2	0483986	LUMINAIRE, DECASHIELD 111 BRONZE 150W HPS	1
3	1186394	LAMP, 150W HPS	1
4	1185978	PHOTOELECTRIC CONTROL	1
5	1192819	#12-2C CONDUCTOR W/GROUND	22'

REVISION	-
	NONE
	REPLACES DRAWING
DATE	06/23/95
DRAWN BY	CLARK/POLLOCK
MANUAL	ESD OVERHEAD & UNDERGROUND LINE DESIGN & CONSTRUCTION
COMPANY	LOUISVILLE GAS & ELECTRIC COMPANY

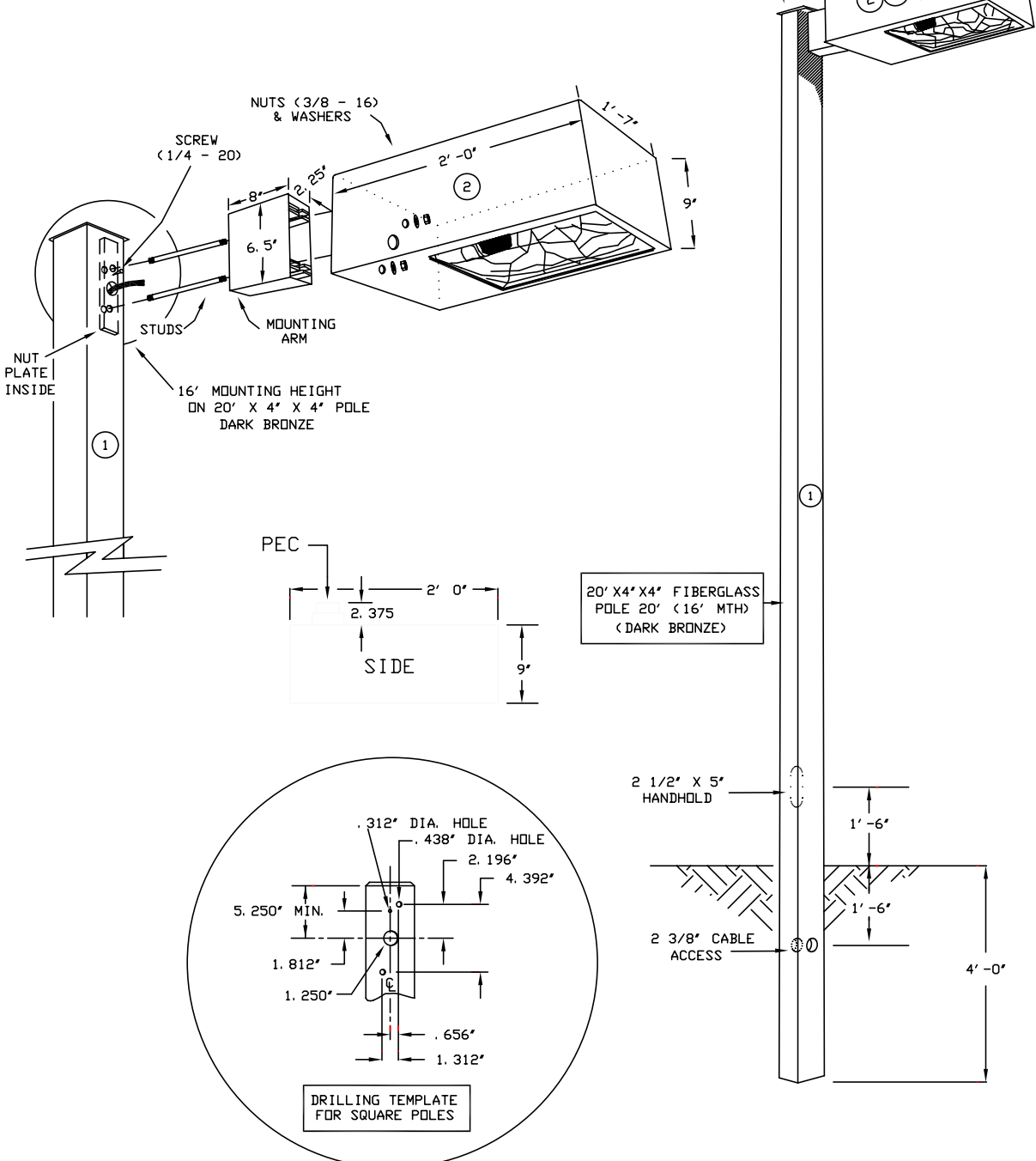

GENERAL:	THIS STANDARD DETAILS THE CONSTRUCTION OF A DECASHIELD III LUMINAIRE 150W HPS ON A 20' X 4" X 4" (16' MTH) DARK BRONZE FIBERGLASS POLE.	DECASHIELD LUMINAIRE 150W HPS / 20' X 4" X 4" BRONZE FIBERGLASS POLE
SCALE	NONE	80 08 23
		SHEET 1 OF 2

SECONDARY SPLICE
 DETAIL (HOT LEGS ONLY)

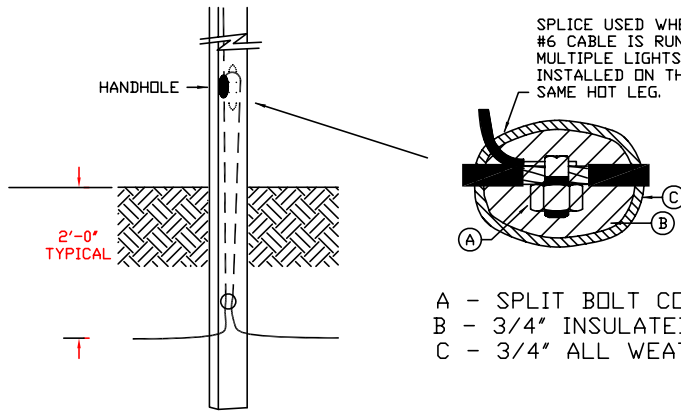

SPLICE USED WHERE
 #6 CABLE IS RUN FOR
 MULTIPLE LIGHTS
 INSTALLED ON THE
 SAME HOT LEG.

- A - SPLIT BOLT CONNECTOR (IIN# VARIES)
- B - 3/4" INSULATED RUBBER TAPE (IIN# 1164435)
- C - 3/4" ALL WEATHER INSULATED TAPE (IIN# 1164401)

MULTIPLE LIGHT FEED
 TO POLES WITH HANDHOLES

TO LUMINAIRE

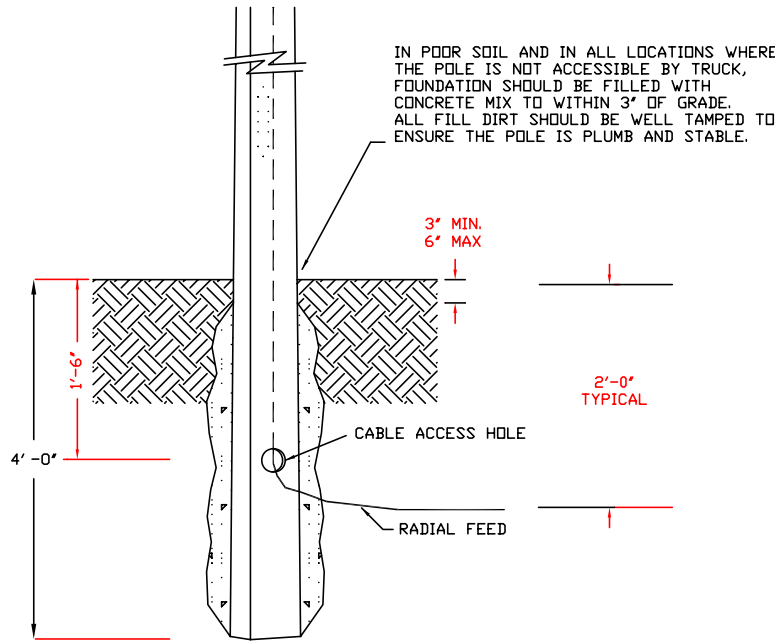

FOUNDATION DETAIL FOR POOR SOIL
 OR NON BUCKET TRUCK ACCESSIBLE
 LOCATIONS

IG&E	
LOUISVILLE GAS & ELECTRIC COMPANY	ET&D OVERHEAD & UNDERGROUND LINE DESIGN & CONSTRUCTION MANUAL
DRAWN BY CLARK/PULLOCK	DATE 6/23/95
REPLACES DRAWING	REVISION
NONE	-

DECASHIELD LUMINAIRE 150W HPS / 20' X 4' X 4' BRONZE FIBERGLASS POLE	
SHEET 2 OF 2	80 08 23
SCALE NONE	

GENERAL: THIS STANDARD DETAILS THE CONSTRUCTION OF A DECASHIELD III LUMINAIRE 150W HPS ON A 20' X 4' X 4' WITH (16' MTH) DARK BRONZE FIBERGLASS POLE.

Electric System
Codes & Standards

FLOOD LIGHT INSTALLATION

80 04 02
Rev. C

ASSEMBLY DESCRIPTION
80 04 02 . XX

- 800402 . 01 SINGLE FLOOD LIGHT MOUNTING
- 800402 . 02 DOUBLE FLOOD LIGHT MOUNTING

NOTE:

1. ALL COPPER CONNECTIONS ARE TO BE MADE USING SPLIT BOLT CONNECTORS.
2. ALL ALUMINUM TO ALUMINUM OR ALUMINUM TO COPPER CONNECTIONS ARE TO BE MADE USING COMPRESSION CONNECTORS.
3. HOT LEG - SPLIT BOLT CONNECTOR TO BE WRAPPED WITH 600V ELECTRICAL TAPE IN DETAIL A AND C.
4. CONNECT GREEN WIRE OF LAMP CORDS TO POLE GROUND AT END OF CORDS. DO NOT SPLICE TO #12 2/C W/GND IF USED.
5. SEE STANDARD 800000 FOR LIGHT FIXTURES, LAMPS AND PHOTO CELLS.

80 04 02 . XX -- MATERIAL LIST

ITEM	IN	DESCRIPTION	01	02
1	1185901	BRACKET FLOODLIGHT DOUBLE-UP OR DOUBLE-DOWN AL		
2	VARIES	5/8" MACHINE BOLT W/NUT		
3	7000337	WASHER, FLAT SQUARE, 2-1/4" X 2-1/4" X 3/16" FOR 5/8" BOLT		
4	7005817	CONDUCTOR OH WIRE, 4, CU BARE, SD, SOLID		
5	1200378	CONNECTOR, SPLIT BOLT, 8 SLD, CU		
6	VARIES	VARIOUS SMALL CONNECTORS		
7	7002252	STAPLE, MOULDING, ROLLED POINT, FOR 1/2" MOULDING, STL		
8	7000913	MOULDING, GROUND, 1/2" X 8F PLASTIC		
9	7001357 OR 7006487	CABLE, 600V #12 SOLID 2/C W/GROUND		
10	7001703 OR 7001368	BRACKET INSULATOR/ARRESTER, 18" SINGLE		
11	7010445	BOLT, MACH, SD HD, 3/4" X 2-1/2" GALV, W/SD NUT		
12	7000349	WASHER, SPLIT LOCK, 234 X 188 FOR 3/4" BOLT, GALV STL		
13	7010442	WASHER, FLAT SQUARE, 3" X 3" X 3/16" FOR 3/4" BOLT, GALV STL		
14	7003001	SCREW, LAG, TWIST DRIVE TEST POINT, 1/2" X 1-1/2"		

* AS REQUIRED

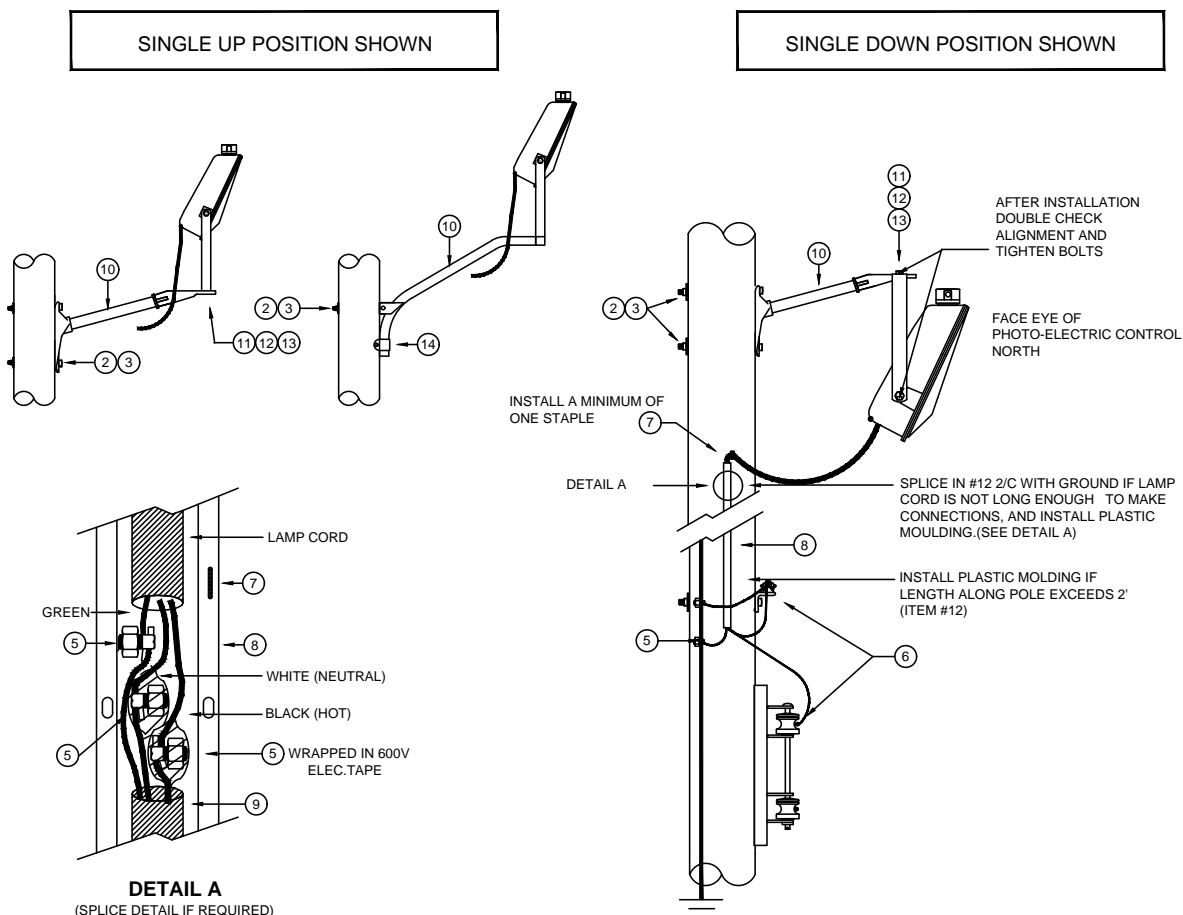

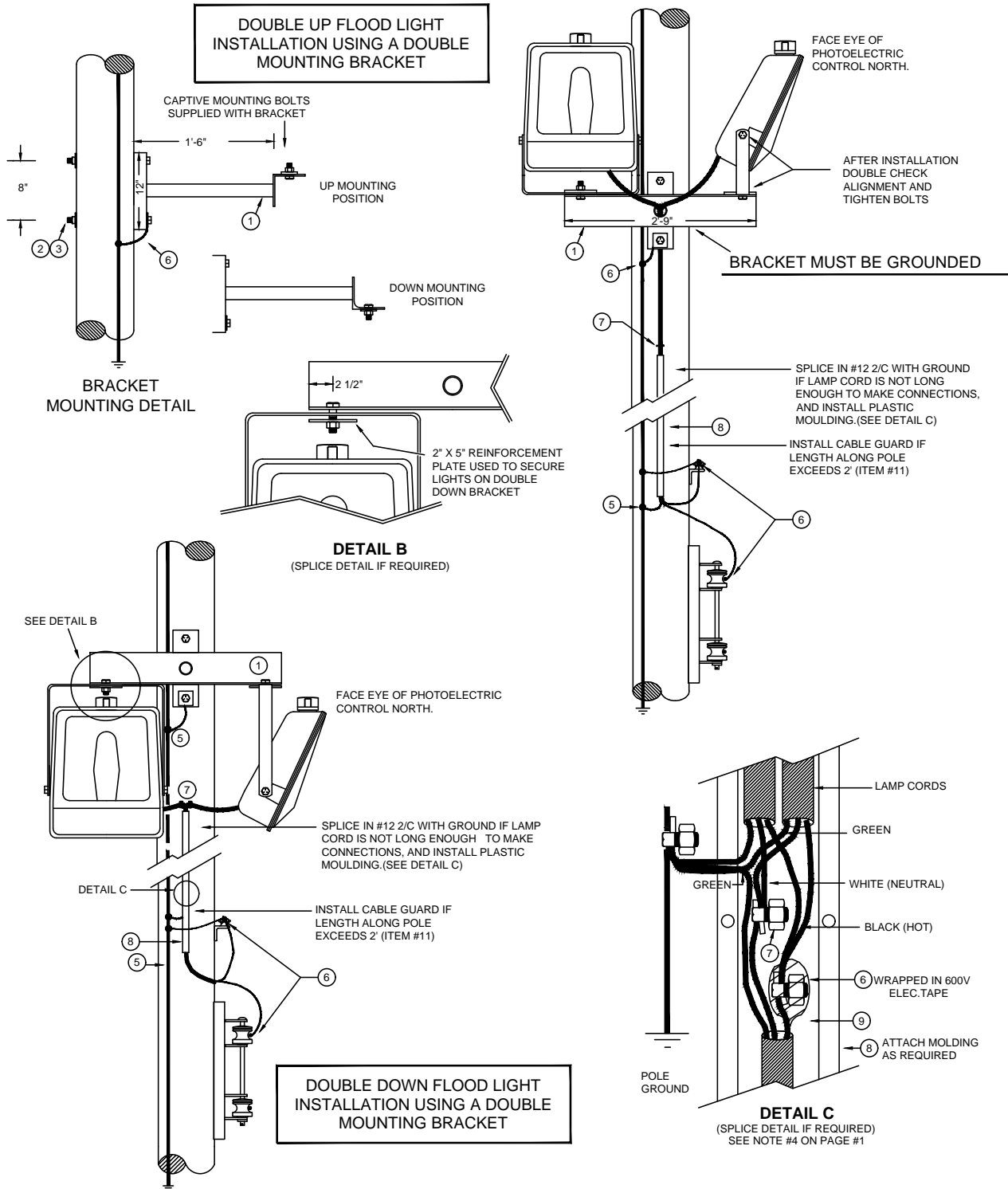

Electric System
 Codes & Standards

30' ALUMINUM DAVIT STREET LIGHT POLE INSTALLATION

80 08 22
 Rev. C

ASSEMBLY DESCRIPTION
 80 08 22 . XX

- TYPE OF POLE AND BASE
- 80 08 22 . 01 30' ALUMINUM DAVIT WITH A WALL THICKNESS OF .188" AND AN ANCHOR BASE MOUNT
 - 80 08 22 . 02 30' ALUMINUM DAVIT WITH A WALL THICKNESS OF .188" AND A T-BASE MOUNT

80 08 22 . XX -- MATERIAL LIST

ITEM	IN	DESCRIPTION	Q1	Q2
1	1192486	POLE AL DAVIT, 30'MTH, 6' ARM, 2" SLIP FITTER	1	1
2	1200360	CONNECTOR, SPLIT BOLT & SLD CU	2	2
3	1164401	TAPE, ELECTRICAL VINYL, 3/4" X 8.5 MIL X 66', BLACK	*	*
4	1164436	TAPE, NON FUSING RUBBER, 3/4" X 30' MIL X 30'	*	*
5	1192527	BASE, TRANSFORMER AL FOR 30' ALUM STREET LT POLES	*	1
6	1199386	WIRE #2, 7-STR SOFT DRAWN COPPER ALPE	*	*
7	7000888	ROD, GROUND, 5/8" X 8', BONDED COPPER	*	*
8	7000887	CLAMP GROUND ROD, 5/8" - 8-1/2', HEX CU, HEAVY DUTY	*	*

* AS REQUIRED

THIS STANDARD DETAILS THE INSTALLATION AND CONNECTION OF A 30' ALUMINUM DAVIT STREET LIGHT POLE. IT INCLUDES POLE, CONNECTING WIRE AND HARDWARE. IT DOES NOT INCLUDE CONCRETE FOUNDATION OR LUMINAIRE.

NOTE:

1. SEE STANDARD 80 08 01 FOR FOUNDATION DETAIL.
2. NEUTRAL CONNECTION IS MADE WITH SPLIT BOLT CONNECTOR ONLY - NO TAPING IS REQUIRED.
3. SPLICING MATERIAL IS INCLUDED IN THIS STANDARD. IF NOT NEEDED OMIT FROM MATERIAL LIST.

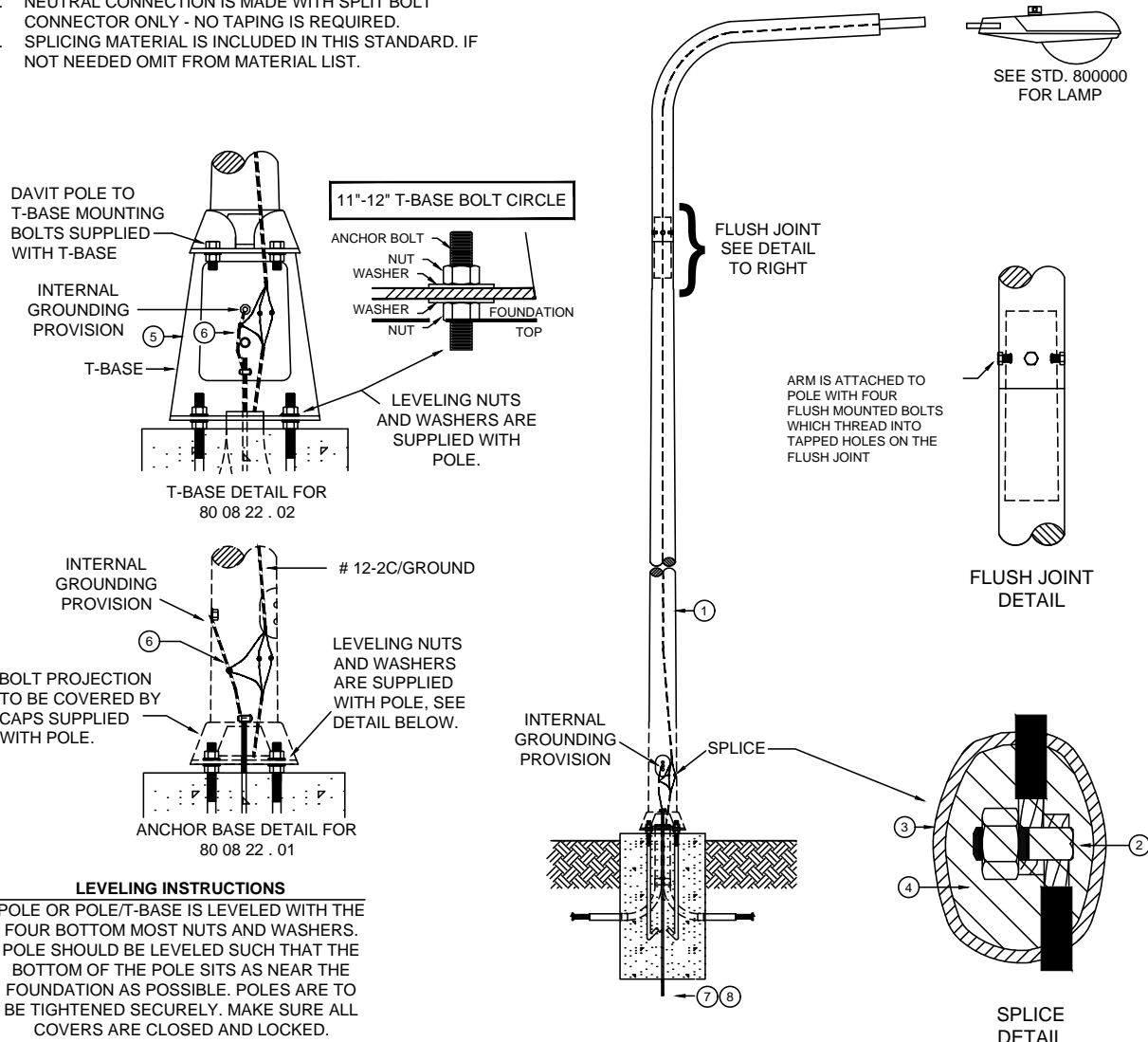

**NESC MINIMUM CLEARANCE REQUIREMENTS FROM
 STREETLIGHTS TO COMMUNICATION FACILITIES**

NESC SECTION 238 REQUIREMENTS (NESC 2017)

NOTE:

1. ALL NEW STREET LIGHT FIXTURES MUST BE EFFECTIVELY GROUNDED. IF UNABLE TO VERIFY GROUND, EITHER USE UNGROUNDED CLEARANCES OR FIXTURE MUST BE GROUNDED.
2. 40" MIN. CLEARANCE MUST BE MET BETWEEN NEUTRAL AND SECONDARY CABLE HARDWARE AND COMMUNICATIONS EQUIPMENT.
3. THE 12" AND 3" CLEARANCE ONLY APPLIES TO THE DRIP LOOP FEEDING THE LUMINAIRE.
4. THE REDUCED 3" CLEARANCE MAY BE USED IF NON-METALLIC COVERING IS PROVIDED AND EXTENDS 2" INTO LUMINAIRE BRACKET.

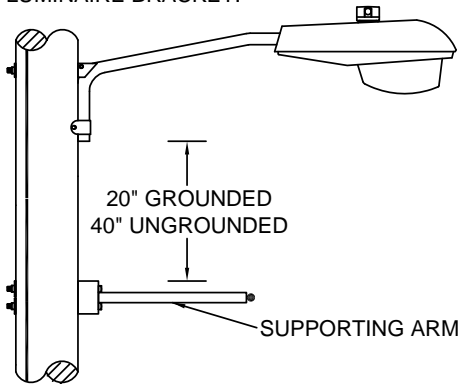

**CLEARANCE FROM
 LUMINAIRE BRACKET TO
 TOP OF COMMUNICATION
 SUPPORTING ARM**

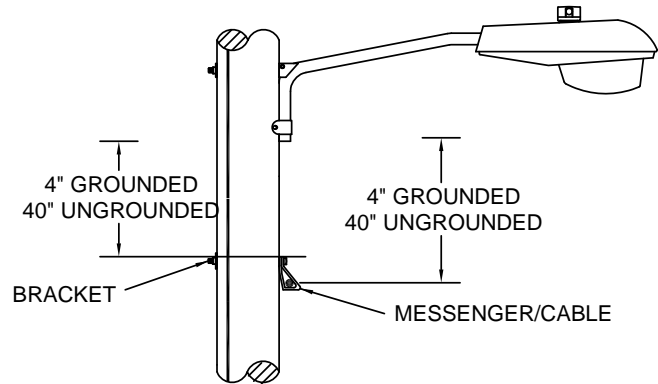

**CLEARANCE FROM LUMINAIRE
 BRACKET TO TOP OF COMMUNICATION
 BRACKET OR CABLE/MESSENGER
 MOUNTED TO POLE
 (BOTH REQUIREMENTS APPLY)**

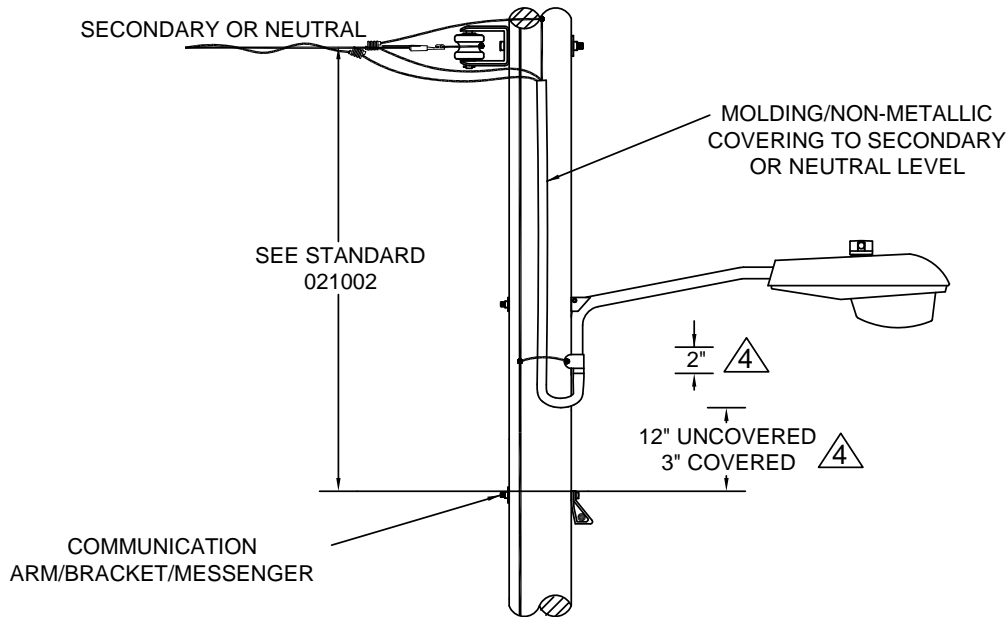

**CLEARANCE FROM DRIP
 LOOP TO TOP OF
 COMMUNICATION
 ARM/BRACKET/MESSENGER**

807 KAR 5:041. Electric.

RELATES TO: KRS Chapter 278

STATUTORY AUTHORITY: KRS 278.280(2)

NECESSITY, FUNCTION, AND CONFORMITY: KRS 278.280(2) provides that the commission shall prescribe rules for the performance of any service or the furnishing of any commodity by the utility. This administrative regulation establishes general rules which apply to electric utilities.

Section 1. Definitions. For purposes of this administrative regulation:

(1) "Applicant" means for purposes of Section 21 of this administrative regulation the developer, builder or other person, partnership, association, corporation or governmental agency applying for the installation of an underground electric supply system.

(2) "Building" means a structure enclosed within exterior walls or fire walls, built, erected and framed of component structural parts and designed for less than five (5) family occupancy.

(3) "Customer" means for purposes of Section 21 of this administrative regulation the developer, builder or other person, partnership, association, corporation or governmental agency applying for installation of an underground electric supply system.

(4) "Customer premises" means the building for which service is intended or in use.

(5) "Distribution system" means electric service facilities consisting of primary and secondary conductors, transformers, and necessary accessories and appurtenances for furnishing electric power at utilization voltage.

(6) "Multiple-occupancy building" means a structure enclosed within exterior walls or fire walls, built, erected and framed of component structural parts and designed to contain five (5) or more individual dwelling units.

(7) "Subdivision" means a tract of land which is divided into ten (10) or more lots for the construction of new residential buildings, or for construction of two (2) or more new multiple occupancy buildings.

Section 2. General Requirements. Every utility shall furnish adequate service and facilities at rates filed with the commission, and in accordance with administrative regulations of the commission and applicable rules of the utility. Energy shall be generated, transmitted, converted and distributed by the utility, and utilized, whether by the utility or the customer, in such manner as to obviate undesirable effects upon the operation of standard services or equipment on the utility, its customers and other utilities.

Section 3. Acceptable Standards. A utility shall construct and maintain its plant and facilities in accordance with good accepted engineering practices. Unless otherwise specified by the commission, the utility shall use applicable provisions in the following publications as standards of accepted good engineering practice for construction and maintenance of plant and facilities, herein incorporated by reference:

(1) National Electrical Safety Code; ANSI C-2. 1990 Edition, available by contacting the IEEE Service Center, 445 Hoes Lane, P.O. Box 1331, Piscataway, New Jersey 08855-1331. This material is also available for inspection and copying, subject to copyright law, at the offices of the Public Service Commission, 211 Sower Boulevard, P.O. Box 615, Frankfort, Kentucky 40602, Monday through Friday between the hours of 8 a.m. to 4:30 p.m. local time.

(2) National Electrical Code; ANSI-NFPA 70. 1990 Edition, available by contacting the National Fire Protection Association, Batterymarch Park, Quincy, Massachusetts 02169. This material is also available for inspection and copying, subject to copyright law, at the offices of the Public Service Commission, 211 Sower Boulevard, P.O. Box 615, Frankfort, Kentucky 40602, Monday through Fri-

day between the hours of 8 a.m. to 4:30 p.m. local time.

(3) American National Standard Code for Electricity Metering; ANSI C-12.1. 1982 Edition, available by contacting the Institute of Electrical and Electronics Engineers, Inc., 345 E. 47th Street, New York, New York 10017;

(4) USA Standard Requirements, for Instrument Transformers; ANSI Standard C57.13, 1978 Edition, available by contacting the IEEE Service Center, 445 Hoes Lane, P.O. Box 1331, Piscataway, New Jersey 08855-1331. This material is also available for inspection and copying, subject to copyright law, at the offices of the Public Service Commission, 211 Sower Boulevard, P.O. Box 615, Frankfort, Kentucky 40602, Monday through Friday between the hours of 8 a.m. to 4:30 p.m. local time.

(5) The adoption and applicability of the National Electrical Code as a standard of utility construction is limited to electric utility auxiliary buildings which are not an integral part of a generating plant, substation, or control center. Integral part is defined as essential to the operation or necessary to make complete.

(6) All materials incorporated by reference above are available for public inspection and copying at the Public Service Commission of Kentucky, 211 Sower Boulevard, Frankfort, Kentucky 40601, between the hours of 8 a.m. and 4:30 p.m.

Section 4. Generating Station Meter Records. Every utility shall install such watt-hour meters as necessary to obtain a record of output of its generating station or stations. Every utility purchasing electrical energy shall install such meters as necessary to furnish a proper record of its purchases, unless such instruments are installed by the selling company.

Section 5. Maintenance or Continuity of Service. (1) Each utility shall make all reasonable efforts to prevent interruptions of service, and when such interruptions occur shall endeavor to reestablish service with the shortest possible delay. Whenever service is necessarily interrupted or curtailed for the purpose of working on equipment, it shall be done at a time if practicable, that will cause least inconvenience to customers, and those customers which may be seriously affected shall be notified in advance, except in cases of emergency.

(2) Each utility shall keep a record of: time of starting and shutting down the principal units of its power station equipment and feeders for major divisions; indications of sufficient switchboard instruments to show voltage and quantity of the load; all interruptions to service affecting the entire distribution system of any single community or important division of a community; and date and time of interruption, date and time of restoring service, and when known, cause of each interruption.

(3) When complete distribution systems or portions of communities have service furnished from unattended stations, the utility shall keep these records to the extent practicable. The records of unattended stations shall show interruptions which require attention to restore service, with estimated time of interruption. Breaker or fuse operations affecting service shall also be indicated even though duration of interruption may not be known.

Section 6. Voltage and Frequency. (1) Each utility shall adopt a standard nominal voltage or standard nominal voltages, as required by its distribution system for its entire constant-voltage service, or for each of several districts into which the systems may be divided, which standard voltages shall be stated in every schedule of rates of each utility or in its terms and conditions of service.

(2) Voltage at the customer's service entrance or connection shall be maintained as follows:

(a) For service rendered primarily for lighting purposes, variation in voltage between 5 p.m. and 11 p.m. shall not be more than five (5) percent plus or minus the nominal voltage adopted, and total variation of voltage from minimum to maximum shall not exceed six (6) percent of the nominal voltage.

(b) 1. For service rendered primarily for power purposes, voltage variation shall not at any time exceed ten (10) percent above or ten (10) percent below standard nominal voltage.

2. Where a limited amount of lighting is permitted under these contracts, the entire load shall be considered power as far as voltage variation is concerned.

(c) Where utility distribution facilities supplying customers are reasonably adequate and of sufficient capacity to carry actual loads normally imposed, the utility may require that starting and operating characteristics of equipment on customer premises shall not cause an instantaneous voltage drop of more than four (4) percent of standard voltage nor cause objectionable flicker in other customer's lights.

(d) Equipment supplying constant current circuits shall be adjusted to furnish as nearly as practicable the rated current of the circuit supplied, and in no case shall the current vary more than four (4) percent above or below the circuit rating.

(3) Each utility supplying alternating current shall adopt a standard frequency of sixty (60) hertz which shall be stated in the schedule of rates of each utility.

(4) A frequency meter monitor shall be maintained for each system frequency. Accuracy of the frequency meter shall be checked each day and frequency shall be governed within limits as set forth in this section so that the frequency meters on the system are correct once daily.

(5) The following shall not be considered a violation of this section: Voltage variations in excess of those caused by operation of power apparatus on customer premises which require large starting currents and affect only the user of such apparatus, by action of the elements and infrequent and unavoidable fluctuations of short duration due to system operation.

(6) Greater variation of voltage than specified under this section may be allowed if service is supplied directly from a transmission line, if emergency service, or if in a limited or extended area in which customers are widely scattered or business done does not justify close voltage administrative regulation. In such cases the best voltage administrative regulation shall be provided that is practicable under the circumstances.

Section 7. Voltage Surveys and Records. (1) Every utility shall have two (2) or more portable indicating voltmeters and two (2) or more recording or graphic voltmeters of type and capacity suited to the voltage supplied. Every utility shall make a sufficient number of voltage surveys to indicate the service furnished from each center of distribution. To satisfy the commission of its compliance with voltage requirements, each utility shall keep at least one (1) of these instruments in continuous service at some representative point on its system. All records of the most recent voltage surveys taken within the last three (3) calendar years shall be available for inspection by the utility's customers and commission staff.

(2) Each graphic recording voltmeter shall be checked with a working standard indicating voltmeter when it is placed in operation and when it is removed, or periodically if the instrument is in a permanent location. Notations on each chart shall indicate beginning time and date of registration and when the chart was removed, as well as the point where voltage was taken, and results of the check with indicating voltmeter.

Section 8. Servicing Utilization Control Equipment. (1) Utilities shall service and maintain any equipment they use on customer's premises and shall adjust thermostats, clocks, relays, or time switches, if such devices must be so adjusted to provide service in accordance with their rate provisions.

(2) Time switches used by the utility for controlling equipment such as water heaters and street lights shall be of such quality that the timing mechanism may be adjusted to be accurate within ten (10) minutes per month. Time switches used by the utility for controlling street lighting or display lighting shall be inspected or monitored at least once a month and, if in error, adjusted. Time switch-

es shall also be adjusted upon complaint if found in error or when service interruptions cause them to be in error by one-half (1/2) hour or more.

(3) Time switches and control devices used by the utility for controlling off-peak appliances shall be inspected or monitored periodically and adjusted if in error, and also adjusted upon complaint if found in error or whenever service interruptions result in error of two (2) hours or more or in supplying service to off-peak appliances during peak periods.

Section 9. Measuring Customer Service. (1) All energy sold within the State of Kentucky shall be measured by commercially acceptable measuring devices owned and maintained by the utility, except where it is impracticable to meter loads, such as multiple street lighting, temporary or special installations, in which case consumption may be calculated. The utility shall meter its own electrical energy use except when such service is for emergency or incidental lighting such as outdoor substations, or at remote points on its transmission or distribution lines. All other electrical quantities which the utility's tariff indicates are to be metered shall be metered by commercially acceptable instruments owned and maintained by the utility.

(2) The utility shall regard each point of delivery as an independent customer and meter the power delivered at each point. Combined meter readings shall not be taken at separate points, nor shall energy used by more than one (1) residence or place of business on one (1) meter be measured to obtain a lower rate.

(3) Metering facilities located at any point where energy may flow in either direction and where the quantities measured are used for billing purposes shall consist of meters equipped with ratchets or other devices to prevent reverse registration and be so connected as to separately meter energy flow in each direction.

(4) Whenever possible reactive meters required to meet the conditions of a given rate schedule shall be either all ratcheted or none shall be ratcheted. Reactive metering shall not be employed for determining average power factor for billing purposes where energy may flow in either direction or where a customer may generate an appreciable amount of his own requirements.

(5) Meters which are not direct reading and those operating from instrument transformers shall have the multiplier plainly marked on the dial of the instrument or otherwise suitably marked and all charts taken from recording meters shall be marked with the record date, meter number, customer and chart multiplier.

(6) The register ratio shall be marked on all electro-mechanical meter registers. Meters already in service may be so marked when they are tested.

(7) The watt-hour constant for the meter itself shall be placed on all watt-hour meters. Meters already in service shall be so marked when they come to the meter shop.

Section 10. Service Connections. (1) The utility shall pay all costs of a service drop or an initial connection to its line with the customer's service outlet, except the attachment of the wire support to customer premises. When the customer's outlet is inaccessible to the utility, or the customer desires that the service outlet on any building be at a location other than that closest to the utility's line, cost of such special construction as necessary shall be borne by the customer. The utility shall furnish at its expense an amount of wire, labor and material equivalent to that furnished for a like service connection not requiring such special construction.

(2) Underground service requirements and administrative regulations shall be established by each utility and be on file with the commission.

(3) All equipment and material furnished by the utility at its own expense shall remain the property of the utility and may be removed by it at any reasonable time after discontinuance of service.

Section 11. Distribution Line Extensions. (1) Normal extensions. An extension of 1,000 feet or

less of single phase line shall be made by a utility to its existing distribution line without charge for a prospective customer who shall apply for and contract to use the service for one (1) year or more and provides guarantee for such service. The "service drop" to customer premises from the distribution line at the last pole shall not be included in the foregoing measurements. This distribution line extension shall be limited to service where installed transformer capacity does not exceed 25 KVA. Any utility which extends service to a customer who may require polyphase service or whose installed transformer capacity will exceed 25 KVA may require the customer to pay in advance additional cost of construction which exceeds that for a single phase line where the installed transformer capacity does not exceed 25 KVA.

(2) Other extensions.

(a) When an extension of the utility's line to serve an applicant or group of applicants amounts to more than 1,000 feet per customer, the utility may, if not inconsistent with its filed tariff, require total cost of the excessive footage over 1,000 feet per customer to be deposited with the utility by the applicant or applicants, based on the average estimated cost per foot of the total extension.

(b) Each customer receiving service under such extension will be reimbursed under the following plan: Each year, for a refund period of not less than ten (10) years, the utility shall refund to the customer(s) who paid for the excessive footage the cost of 1,000 feet of extension in place for each additional customer connected during the year whose service line is directly connected to the extension installed and not to extensions or laterals therefrom. Total amount refunded shall not exceed the amount paid the utility. No refund shall be made after the refund period ends.

(c) For additional customers connected to an extension or lateral from the distribution line, the utility shall refund to any customer who paid for excessive footage the cost of 1,000 feet of line less the length of the lateral or extension.

(3) An applicant desiring an extension to a proposed real estate subdivision may be required to pay the entire cost of the extension. Each year, for a period of not less than ten (10) years, the utility shall refund to the applicant who paid for the extension a sum equivalent to the cost of 1,000 feet of the extension installed for each additional customer connected during the year. Total amount refunded shall not exceed the amount paid to the utility. No refund shall be made after the refund period ends.

(4) Nothing contained herein shall be construed as to prohibit the utility from making extensions under different arrangements if such arrangements have been approved by the commission.

(5) Nothing contained herein shall be construed to prohibit a utility from making at its expense greater extensions than herein prescribed, if similar free extensions are made to other customers under similar conditions.

(6) Upon complaint to and investigation by the commission, a utility may be required to construct extensions greater than 1,000 feet upon a finding by the commission that such extension is reasonable.

Section 12. Distribution Line Extensions to Mobile Homes. (1) All extensions of up to 150 feet from the nearest distribution line shall be made without charge.

(2) Extensions greater than 150 feet from the nearest distribution line and up to 300 feet shall be made if the customer pays the utility a "customer advance for construction" of fifty (50) dollars in addition to any other charges required by the utility for all customers. This advance shall be refunded at the end of one (1) year if service to the mobile home continues for that length of time.

(3) For extensions greater than 300 feet and less than 1,000 feet from the nearest distribution line, the utility may charge an advance equal to reasonable costs incurred by it for that portion of service beyond 300 feet plus fifty (50) dollars. Beyond 1,000 feet the extension policies set forth in Section 11 of this administrative regulation shall apply.

(a) This advance shall be refunded to the customer over a four (4) year period in equal amounts

for each year service is continued. The customer advance for construction of fifty (50) dollars shall be added to the first of four (4) refunds.

(b) If service is discontinued for a period of sixty (60) days, or the mobile home is removed and another does not take its place within sixty (60) days, or is not replaced by a permanent structure, the remainder of the advance shall be forfeited.

(c) No refunds shall be made to any customer who did not make the advance originally.

(4) If a utility implements specific requirements pertaining to mobile homes, such requirements shall be subject to approval by the commission and comply with the provisions of this administrative regulation.

Section 13. Testing Equipment and Standards. (1) Each utility shall maintain sufficient laboratories, meter testing shops, standards, instruments and facilities to determine accuracy of all types of meters and measuring devices used by the utility except as provided in 807 KAR 5:006, Section 17.

(2) The following testing equipment shall be available as minimum requirements for each utility or agency making tests or checks for a utility pursuant to 807 KAR 5:006, Section 17(2):

(a) One (1) or more working watt-hour standards and associated devices of capacity and voltage range adequate to test all watt-hour meters used by the utility.

(b) One (1) or more watt-hour standards, which shall be the utility's master watt-hour standards, used for testing the working watt-hour standards of the utility. These standards shall be of an approved type, shall be well compensated for both classes of temperature errors, practically free from errors due to ordinary voltage variations, and free from erratic registration. These master watt-hour standards shall be of capacity and voltage range adequate to test all working watt-hour standards at all loads and voltages at which they are used. These standards shall be kept permanently at one place and not used for routine testing.

(c) Working indicating instruments, such as ammeters, voltmeters and watt-meters, of such various types required to determine the quality of service to customers.

(d) A voltmeter and ammeter, which shall be master indicating instruments, and which shall be used for testing of working indicating and recording instruments. These instruments shall be of an approved type and of accuracy class and range sufficient to determine accuracy of working instruments to within five-tenths (0.5) percent of all ranges and scale deflections at which working instruments are used. They shall be kept permanently at one place and not used for routine testing.

(3) The utility's master watt-hour standards shall not be in error by more than plus or minus three-tenths (0.3) percent at 100 percent power factor, nor more than plus or minus five-tenths (0.5) percent at fifty (50) percent power factor at loads and voltages at which they are used, and shall not be used to check or calibrate working standards unless the master standard has been certified as to accuracy by the commission within the preceding twelve (12) months. Each master watt-hour standard shall have a history card and calibration data available, and when used to calibrate working standards, correction for any error of the master standard shall be applied.

(4) All working watt-hour standards when regularly used shall be compared with a master standard at least once in every four (4) weeks. Working watt-hour standards infrequently used shall be compared with a master standard before they are used.

(5) Working watt-hour standards shall be adjusted, if necessary, so that their accuracy will be within plus or minus three-tenths (0.3) percent at 100 percent power factor and within plus or minus five-tenths (0.5) percent at fifty (50) percent lagging power factor at all voltages and loads at which the standard may be used. A history and calibration record shall be kept for each working watt-hour standard showing all pertinent data and name of person performing tests.

(6) After having adjusted working watt-hour standards to the accuracy specified above, service measuring equipment shall be adjusted to within the accuracies required, assuming working watt-hour standards to be 100 percent accurate.

(7) If calibration charts are attached to working watt-hour standards and the error indicated is applied to all tests run and the accuracy on any range has not varied more than two-tenths (0.2) percent during the past twelve (12) regular test periods, accuracy limits may be extended to plus or minus five-tenths (0.5) percent at 100 percent power factor and plus or minus seven-tenths (0.7) percent at fifty (50) percent lagging power factor at all voltages and loads at which the standard may be used.

(8) The utility's master indicating instruments shall not be in error by more than plus or minus five-tenths (0.5) percent of indication at commonly used scale deflections and shall not be used to check or calibrate working indicating instruments unless the master instrument has been checked and adjusted, if necessary, and certified as to accuracy by the commission within the preceding twenty-four (24) months. A calibration record shall be maintained for each instrument.

(9) All working indicating instruments shall be checked against master indicating instruments at least once in each six (6) months. If the working instrument is found appreciably in error at zero or in error by more than one (1) percent of indication at commonly used scale deflections, it shall be adjusted. A calibration record shall be maintained for each instrument showing all pertinent data and name of person performing tests.

Section 14. Check of Standards by Commission. (1) Each utility, and/or agency making tests or checks for a utility, shall submit to the commission Meter Standards Laboratory, its master watt-hour standard once in each year, and its master indicating voltmeter and ammeter once in each two (2) years.

(2) At the discretion of the commission any or all of these required tests may be made at the utility's or agency's testing facility by means of portable transfer standards. If the standards satisfy the requirements of the commission a Certificate of Accuracy shall be issued by the commission's Division of Engineering.

(3) Each utility which normally checks its own master watt-hour standards and master indicating instruments against primary standards such as precision watt-meters, volt boxes, resistances, standard cells, potentiometers, and timing devices, shall calibrate the master watt-hour standards and indicating instruments before they are submitted to the commission for test, and attach to them a record of such calibration.

Section 15. Testing of Metering Equipment. (1) Testing of any unit of metering equipment shall consist of a comparison of its accuracy with a standard of known accuracy. All metering equipment shall be in good order, and shall be adjusted to as close to zero error as possible.

(2) No meter or measuring device shall be deliberately set in error by any amount. Because of unavoidable irregularities of work done on a commercial scale, some accuracy tolerance shall be allowed. Meters shall be set as near as practicable to 100 percent accuracy but in no case shall the inaccuracy exceed one (1) percent. Further, meters with defective parts shall be repaired regardless of their accuracy.

(3) Metering equipment, including instrument transformers and demand meters, shall be tested for accuracy prior to being placed in service, periodically in accordance with the schedule below, upon complaint, when suspected of being in error, or when removed from service for any cause.

Period Test Schedule	
Self-Contained Meters	
Single phase	8 years
3 wire network	8 years
Polyphase	6 years
Meters used with instrument transformers	

	Single phase	6 years
	Polyphase	4 years
Demand Meters		
	Indicating block-interval and lagged-demand meters	same as associated watt-hour meter
	Graphic and pulse operated recording demand meters	2 years
Instrument Transformers		
	Current: high burden test	same as associated watt-hour meter
	Potential: secondary voltage test	same as associated watt-hour meter
	Var-hour Meters	same as associated watt-hour meter
Direct Current Watt-hour Meters:		
	Up to and including 6 KW	4 years
	Over 6 KW through 100 KW	2 years
	Over 100 KW	1 year

(4) Tests may be made at a meter shop, on the customer's premises, or in a mobile shop.

Section 16. Sample Testing of Single Phase Meters. A utility desiring to adopt a scientific sample meter testing plan for single phase meters shall submit its application to the commission for approval. Upon approval the sample testing plan may be followed in lieu of the periodic test prescribed in Section 15(3) of this administrative regulation. The plan shall include the following:

- (1) Meters shall be divided into separate groups to recognize differences in operating characteristics due to changes in design, taking into consideration date of manufacture and serial number.
- (2) The sampling procedure shall be based upon accepted statistical principles.
- (3) The same sampling procedure shall be applied to each group.
- (4) Each utility authorized to test meters by sample meter testing plan shall comply with the following conditions:
 - (a) The number of meters in addition to the sample shall be taken from those meters in each group longest in service since last test unless a particular meter type is known to be increasing the percentage of meters requiring test for the sample group. In such a case where a particular meter type is increasing the percentage of meters requiring test in any group, these meters may be selected first regardless of test date with any additional tests as required for that group coming from those in that group longest in service since last test. Each year the utility shall use the following table to determine the percentage of the total meters in each group to be tested.

Percentage of Meters Within Limits of 2% Fast or Slow (Indicated by Sample)		Percentage of Meters to be Tested the Next Year
99.0	100.0	2
98.0	98.9	4
97.0	97.9	6
96.0	96.9	8
95.0	95.9	10
93.0	94.9	12
91.0	92.9	14
Less than	91.0	16

(b) Provided, however, that no meter shall remain in service without periodic test for a period longer than twenty-five (25) years.

(5) Whenever a meter is found to be more than two (2) percent fast or slow, refunds or back billing shall be made for the period during which the meter error is known to have existed or if not known for one-half (1/2) the elapsed time since the last test but in no case to exceed three (3) years. This provision shall apply only when sample testing of single phase meters has been approved by the commission and utilized by the utility.

Section 17. Test Procedures and Accuracy Requirements. (1) Meters and associated devices shall be tested at the loads indicated below and adjusted as close as practicable to zero error when found to exceed the tolerance prescribed below.

AC Watt-hour Meters		
% of Test Current	Power Factor	Allowable Tolerance
100	1.0	+ or - 1.0%
10	1.0	+ or - 1.0%
100	0.5	+ or - 1.0%
DC Watt-hour Meters		
% of Test Current		Allowable Tolerance
100	1.0%	
10	1.0%	

(a) Only one (1) test run shall normally be required at each test configuration. However if the test indicates the meter is more than two (2) percent in error fast or slow, additional tests shall be made to verify accuracy prior to refunding or back billing the customer.

(b) When a meter is tested on complaint or request, additional test runs shall be made and care exercised to insure that any trouble with the meter will be detected.

(c) For refund and back billing purposes, accuracy of the meter shall be determined by adding the average registration at light load (ten (10) percent of test current) and the average registration at full load (100 percent of test current) and dividing by two (2).

(2) Demand meters. A demand meter, demand register, or demand attachment used to measure customer's service shall:

- (a) Be in good mechanical and electrical condition.
- (b) Have proper constants, indicating scale, contact device, and resetting device.
- (c) Not register at no load.

(d) Be accurate to the following degrees:

1. Graphic meters which record quantity-time curves and integrated-demand meters shall be accurate to within plus or minus two (2) percent of full scale throughout their working range. Timing elements measuring specific demand intervals shall be accurate to within plus or minus two (2) percent and the timing element which serves to provide a record of the time of day when demand occurs shall be accurate to within plus or minus four (4) minutes in twenty-four (24) hours.

2. Lagged-demand meters shall be accurate to within plus or minus two (2) percent at final indication.

(3) Instrument transformers.

(a) Instrument transformers used in conjunction with metering equipment to measure customer's service shall:

1. Be in proper mechanical condition and have electrical insulation satisfactory for the service on which used.

2. Have characteristics such that the combined inaccuracies of all transformers supplying one (1) or more meters in a given installation shall not exceed the following:

	100% Power Factor		50% Power Factor	
	10% Current	100% Current	10% Current	100% Current
Purchased after Jan. 1, 1942	1%	.75%	3%	2%
Purchased prior to Jan. 1, 1942	2%	1.50%	5%	3%

(b) Meters used in conjunction with instrument transformers shall be adjusted so that overall accuracies will come within the limits specified in this administrative regulation.

(c) Instrument transformers shall be tested with the meter with which they are associated by making an overall test, or may be checked separately. If transformers are tested separately, meters shall also be checked to see that overall accuracy of installation is within the prescribed accuracy requirements.

(d) Results of tests of instrument transformers shall be kept on record and be available for use during the life of the transformer.

(e) Phase shifting transformers shall have secondary voltages under balanced line voltage conditions within one (1) percent plus or minus of the voltage impressed on the primary.

Section 18. Location of Meters. (1) Meters shall be installed in a clean, dry, safe, convenient place as free as possible from vibration. Meters shall be easily accessible for reading, testing, and making necessary adjustments and repairs, and where indoor type meters are necessary they shall not be placed in coal or wood bins or on partitions forming bins, nor on any unstable supports. Unless absolutely unavoidable, meters shall not be installed in attics, sitting rooms, bathrooms, bedrooms, restaurant kitchens, over doors, over windows, or in any location where visits of the meter reader or tester will cause annoyance to the customer or a severe inconvenience to the utility.

(2) Districts subject to flood are excepted from this rule as far as it applies to the location of meters.

(3) Proper provision shall be made by the customer for installation of the utility's meter. Unless the

meter is to be mounted upon a panel or installed within a cabinet, such provision shall consist of a board not less than three-quarters (3/4) of an inch in thickness which shall be mounted not less than five (5) or not more than seven (7) feet from the floor, and in general as near as possible to point of entrance of service. At least six (6) inches clear space shall be available, on all sides of the meter board and not less than thirty (30) inches in front of it. The above provisions as to method of mounting and height from floor do not apply to the installation of weatherproof outdoor meters. Electric meters shall not be installed close to either water or gas meters or anything liable to damage the meter, thereby constituting a hazard to customer's safety and continuous service.

(4) When more than one (1) meter is installed without a meter cabinet in the same building, proper space shall be allotted and provision made by the customer for locating the meters at one (1) place. When a number of meters are placed in the same cabinet or upon the same board, each meter shall be tagged or marked to indicate the circuit metered by it.

Section 19. Overhead and Underground Wire Entrances. (1) The overhead wire entrance shall be located on the exterior of the building nearest the utility's lines at a point not less than twelve (12) nor more than thirty (30) feet above the ground. When proper ground clearance cannot be obtained due to height of building, a proper supporting structure shall be provided by the customer unless arrangements can be made with the utility whereby their overhead service wires can be carried to the building in such a manner that these wires will not constitute an obstruction to free passage of vehicles or fire fighting apparatus.

(2) Approval shall be obtained from the utility as to the proper location for a service entrance.

(3) New service drops, both overhead and underground, shall be installed in accordance with the National Electrical Safety Code.

Section 20. Operation of Illegal Gambling Devices. (1) When an electric utility, subject to the jurisdiction of this commission, is notified in writing by a federal or state law enforcement agency, the Attorney General of Kentucky, a Commonwealth's Attorney or a County Attorney acting in his official capacity, that electric energy furnished by it is being used or will be used for operating an illegal gambling device, it shall discontinue rendering electric service to such customer, after reasonable notice to the customer. No damages, penalty or forfeiture, civil or criminal, shall be found against any electric utility for any act done in compliance with any such notice received from the law enforcement agency or officer. Nothing in this section shall be deemed to prejudice the right of any person affected thereby to secure an appropriate judicial determination that such service should not be discontinued, or should be restored.

(2) As provided by KRS 278.230, any electric utility subject to commission jurisdiction shall furnish to the commission upon request any records or information in the possession of such electric utility that may assist in the enforcement of this rule.

Section 21. Underground Electric Distribution Systems for New Residential Customers. (1) Purpose of rules. To formulate requirements for underground electric distribution systems for all new customers of those systems which will insure safe and adequate service and which will be uniformly applicable within a utility's service area.

(2) Applicability. New residential customers and subdivisions as defined below after the effective date of this rule.

(3) Rights of way and easements.

(a) The utility shall construct, own, operate and maintain distribution lines only along easements, public streets, roads and highways which are by legal right accessible to the utility's equipment and which the utility has legal right to occupy, and on public lands and private property across which rights of way and easements satisfactory to the utility may be obtained without cost or condemnation

by the utility.

(b) Rights of way and easements suitable to the utility for underground distribution facilities shall be furnished by the applicant in reasonable time to meet service requirements. The utility may require that the applicant make the area in which underground distribution facilities are to be located accessible to the company's equipment, remove all obstructions from such area, stake to show property lines and final grade, perform rough grading to reasonable approximation of final grade, and maintain clearing and grading during construction by the utility. The utility may require that suitable land rights be granted to it, obligating the applicant and subsequent property owners to provide continuing access to the utility for operation, maintenance or replacement of its facilities, and to prevent any encroachment in the utility's easement or substantial changes in grade or elevation.

(4) Installation of underground distribution system within new subdivision.

(a) Where appropriate contractual arrangements have been made, the utility shall install within the subdivision an underground electric distribution system of sufficient capacity and suitable materials which, in its judgment, will assure that the property owners will receive safe and adequate electric service for the foreseeable future.

(b) Facilities required to be underground:

1. All single phase conductors installed by the utility shall be underground. Appurtenances such as transformers, pedestal-mounted terminals, switching equipment and meter cabinets may be placed above ground.

2. Three (3) phase primary mains or feeders required within a subdivision to supply local distribution or to serve individual three (3) phase loads may be overhead unless underground is required by governmental authority or chosen by the applicant, in either of which case the differential cost of underground shall be borne by the applicant.

(c) If the applicant has complied with the requirements herein and with the utility's specifications on file with the commission, and has given the utility not less than 120 days written notice prior to anticipated date of completion (i.e., ready for occupancy) of the first building in the subdivision, the utility shall complete installation thirty (30) days prior to estimated completion date. (Subject to weather and ground conditions and availability of materials and barring extraordinary or emergency circumstances beyond reasonable control of the utility.) However, nothing in these administrative regulations shall be interpreted to require the utility to extend service to portions of subdivisions not under active development.

(5) Schedule of charges.

(a) Within sixty (60) days after the effective date of these rules, each utility shall file with the commission a statement setting forth the utility's policy with respect to electric underground extensions. Such policy shall provide for payment by the applicant for the difference between the cost of providing underground facilities and that of providing overhead facilities. The payment made by applicant shall be expressed in terms of an amount per foot of conductor or other appropriate measure.

(b) The utility's policy as filed with the commission shall set forth an "estimated average cost differential," if any, between the average or representative cost of underground distribution systems and of equivalent overhead distribution systems within the utility's service areas. The payment made by applicant as provided for in paragraph (a) of this subsection shall not be more than the estimated average cost differential and shall be nonrefundable.

(c) Detailed supporting data used to determine estimated average cost differential shall be concurrently filed by the utility with the commission and shall be updated annually.

(d) Applicant may be required to deposit the entire estimated cost of the extension. If this is done, the amount deposited in excess of the normal charge for underground extensions, as provided in paragraph (a) of this subsection, shall be refunded to the applicant over a ten (10) year period as provided in Section 11 of this administrative regulation.

(e) Upon agreement by both parties, if the applicant chooses to perform all necessary trenching and backfilling in accordance with utility specifications, the utility shall credit applicant's cost in an amount equal to the utility's cost for trenching and backfilling.

(f) Utility extension from the property or boundary of the subdivision to its existing supply facilities shall normally be made overhead, and any deposit required for that extension is subject to refund under Section 11 of this administrative regulation. Upon request, such extension may be made underground, if the applicant agrees to pay the excess cost for the underground extension, which excess cost shall be nonrefundable.

(g)1. Point of service shall be that point where utility facilities join customer facilities, irrespective of the location of the meter. Such point of service shall normally be either at the property line or at the corner of the building nearest the point at which underground systems enter the property to be served, depending upon whether the utility or the customer owns the underground service lateral.

2. If established utility practice dictates service termination at the customer's property line, the utility shall credit the applicant fifty (50) dollars or the equivalent cost of an overhead service line to the applicant's meter base, whichever is greater.

3. Where established utility practice does not dictate service termination at the customer property line, the utility shall include in its underground plan the furnishing, installation, ownership, and maintenance of the service lateral to the meter base providing the applicant installs in the building adequate electric service entrance capacity to the satisfaction of the utility to assure that the underground service conductors will be adequate to handle present and future load requirements of the building. In this instance the utility will determine the size and type of service lateral conductors and appurtenances to be used in any installation.

4. If, by mutual agreement of the parties, service terminates at some other point on the building or property, the applicant shall pay the full cost of any additional extension required in excess of that provided for in paragraph (g)1, 2 and 3 of this subsection.

(h) When an existing utility-owned supply circuit or service lateral requires replacement or reinforcement due to added loads, etc., the utility at its expense will replace or reinforce it.

(i) Nothing in this administrative regulation shall be construed to prevent any utility from assuming any part of the cost differential of providing underground distribution systems within subdivisions, provided the utility demonstrates to the commission that such practice will not result in increased rates to the general body of rate payers.

(j) The utility shall not be obligated to install any facility within a subdivision until satisfactory arrangements for payment of charges have been completed by the applicant.

(6) Cooperation by applicant. Charges specified in these rules are based on the premise that each applicant will cooperate with the utility in an effort to keep the cost of construction and installation of the underground electric distribution system as low as possible and make satisfactory arrangements for payment of the above charges prior to installation of the facilities.

(7) Construction. All electrical facilities shall be installed and constructed to comply with applicable codes, rules and administrative regulations of the commission.

Section 22. Deviations from Rules. In special cases for good cause shown the commission may permit deviations from these rules. (8 Ky.R. 814; eff. 4-7-1982; Am. 16 Ky.R. 2046; 2430; eff. 6-10-1990; 17 Ky.R. 2507; eff. 4-4-1991; TAm 1-30-2013.)

LOUISVILLE GAS AND ELECTRIC COMPANY

**Response to First Request for Information of the
Louisville/Jefferson County Metro Government
Dated November 13, 2018**

Case No. 2018-00295

Question No. 23

Responding Witness: John K. Wolfe

Q-23. Please describe in detail all maintenance that must be performed by LG&E on each type of street light to ensure that it operates properly and provide a list of each component of the required maintenance and its monthly cost.

A-23. Normal maintenance consists of replacing the items listed in the table below as needed. The current unit costs are for materials specific to each installation and do not include associated installation costs (labor, minor materials, equipment, etc.), which are not tracked at this level of detail. Maintenance is required when LG&E has identified or received a report that the street light is inoperative. The most common maintenance performed on a street light is the replacement of a burned out bulb and/or replacement of an inoperative photoelectric control.

Normal Street Light Maintenance Material

Item #	Unit Description	Unit Cost
7001343	LAMP, HPS,4000L,50W	\$7.58
7001344	LAMP,HPS,5800L,70W	\$6.85
7001345	LAMP, HPS, 100W, 9500L	\$6.85
1186394	LAMP, HPS, 150W, 16000L	\$8.23
1186401	LAMP, HPS, 250W, 100V, 27500L	\$7.34
7001347	LAMP, HPS, 400W, 100V, 50000L	\$8.42
0949519	LAMP, HPS, 1000W	\$34.06
7001348	LAMP, MV, 175W, 8000L, DELUXE WHITE	\$5.51
7001349	LAMP, MV, 250W, 13000L, DELUXE WHITE	\$6.39
7001350	LAMP, MV, 400W, 25000L, DELUXE WHITE	\$7.32
3005449	LAMP, PULSE START MH, 150W, MEDIUM BASE	\$19.78
3005450	LAMP, PULSE START MH, 350W, MOGUL BASE	\$23.21
7005980	LAMP, MH, 1000W, 110000L	\$22.98

7001331	CONTROL,PHOTOELECTRIC,ELECTRONIC,105/130 VOLTS,1000W.,1800VA.,GRAY COVER,CDDMIUM-SULFIDE PHOTOCELL,MINIMUM 160 JOULE MOV ARRESTER,TWIST LOCK BASE,DUSK TO DAWN, USE IN 120V ONLY	\$3.13
7001332	CONTROL,PHOTOELECTRIC,ELECTRONIC,105/285V,1000W, 1800VA,BLUE COVER,CADMIUM SULFIDE PHOTOCELL,MINUMUM 160 JOULE MOV ARRESTER,TWISTLOCK BASE,DUSK TO DAWN, USE ON 240V ONLY	\$3.46
0455127	CONTROL,PHOTOELECTRIC,ELECTRONIC,TWIST-LOCK BASE,YELLOW COVER,420/530 VOLTS,1000W,1800VA,CADMIUM-SULFIDE PHOTOCELL,MINIMUM 160 JOULE MOV ARRESTOR,DUSK TO DAWN, USE ONLY ON 480V	\$9.58
7001718	CAP,SHORTING,LOCKING TYPE, TO SHUNT LUMINAIRE CIRCUIT SO THE FEED COULD BE FROM A REMOTE LOCATION	\$3.39
7010269	STARTER,LIGHTING,HPS,50W-400W,PLUG IN TYPE	\$20.51

LOUISVILLE GAS AND ELECTRIC COMPANY

**Response to First Request for Information of the
Louisville/Jefferson County Metro Government
Dated November 13, 2018**

Case No. 2018-00295

Question No. 24

Responding Witness: John K. Wolfe

- Q-24. Please provide both the number and type of public street lights for Louisville Metro accounts for which service or maintenance was performed in each of the last three years and the same information for LG&E entire system. In addition, please provide the basis for generating the above repair or maintenance order (i.e., referral from 311, customer complaint, LG&E) for each of the above.
- A-24. LG&E system-wide repair orders for street and other outdoor lights during the periods in question are in the table below (2018 through 11/15/2018). LG&E does not track repairs by type. LG&E does not track street light repairs by customer.

	2016	2017	2018
System-wide	13,396	11,757	10,688

LG&E does not track repairs by reporting source.

LOUISVILLE GAS AND ELECTRIC COMPANY

**Response to First Request for Information of the
Louisville/Jefferson County Metro Government
Dated November 13, 2018**

Case No. 2018-00295

Question No. 25

Responding Witness: John K. Wolfe

- Q-25. Provide the average time to repair a malfunctioning street light from the time of discovery, either by public reporting or Company representative, to the time the light is restored to operation.
- A-25. For LG&E, the average time to repair a street light for 2018, through September, was 2 days. For 2017, the average time to repair a street light was 1.98 days.

LOUISVILLE GAS AND ELECTRIC COMPANY

**Response to First Request for Information of the
Louisville/Jefferson County Metro Government
Dated November 13, 2018**

Case No. 2018-00295

Question No. 26

Responding Witness: John K. Wolfe

- Q-26. Provide a chart of maintenance and repair calls for each street light for Louisville Metro and the total cost for each call, including both materials and labor.
- A-26. Repairs are not tracked by customer. See attached being provided in Excel format for a chart of maintenance and repair calls by address for all of Jefferson County, for 2017 to November 15, 2018. System-wide, LG&E has approximately 12,600 streetlight work orders per year at an approximate average cost of \$310 per order.

The attachment is being provided in a separate file in Excel format.

LOUISVILLE GAS AND ELECTRIC COMPANY

**Response to First Request for Information of the
Louisville/Jefferson County Metro Government
Dated November 13, 2018**

Case No. 2018-00295

Question No. 27

Responding Witness: John K. Wolfe

Q-27. Provide separately the number of calls from the public regarding street lights paid for by Louisville Metro and the rest of the Company's system.

A-27. LG&E does not track the number of calls from the public.

LOUISVILLE GAS AND ELECTRIC COMPANY

**Response to First Request for Information of the
Louisville/Jefferson County Metro Government
Dated November 13, 2018**

Case No. 2018-00295

Question No. 28

Responding Witness: John K. Wolfe

Q-28. Provide any internal policies or procedures with regards to street light maintenance, repair and replacement.

A-28. The procedure for street light maintenance, repair, and replacement consists of the following work practices:

- A reported light outage will be investigated within 2 working days by a trouble shooter or service technician.
 - Initial response is comprised of checking the bulb, photocell, voltage, and starter (if applicable).
 - Replacement of any of these failed components will be conducted at that time.
 - If it is identified that none of the above components are responsible for the lighting failure, the work will be transferred to the lighting repair work queue.
- A second-level response to light outages involves further investigation into the cause of the voltage failure.
 - Typical causes include:
 - Fuses,
 - Third party damage (dig-ins),
 - Failed conductors.
 - Dependent on the type of repair needed, repairs may be made at this time or scheduled for a later date.
- A third-level response will include replacement of a feed to the light or a chain of lights.
 - This replacement would be conducted by means of boring, plowing, or trenching a new feed in conduit.
 - The time frame for this repair will be heavily dependent on weather, customer or city property impacts, and/or soil dynamics

See also the response to Question No. 22.

LOUISVILLE GAS AND ELECTRIC COMPANY

**Response to First Request for Information of the
Louisville/Jefferson County Metro Government
Dated November 13, 2018**

Case No. 2018-00295

Question No. 29

Responding Witness: John K. Wolfe

- Q-29. Is LG&E able to ascertain, at any given time, the number of street lights paid for by Louisville Metro that are actually in proper working order? If so, please provide a detailed explanation, and further explain:
- a. How many street lights (on average) are actually in proper working order at any given time;
 - b. Whether the Louisville Metro is charged the monthly tariff rate for non-working street lights for the periods of time within which such street lights are non-operational or not working properly;
 - c. The amount of time it takes (on average) to bring such street lights into working order; and
 - d. Whether this information differs among different types of street lights. If so, please provide this information for each type of light.
- A-29. No, LG&E cannot ascertain the number of street lights that are paid for by Louisville Metro that are operable at any given time. However, as described in the response to Question No. 22 (a), LG&E proactively identifies street light outages and relies upon customers to report service problems.
- a. All lights, unless reported otherwise, are considered to be in proper working order.
 - b. Louisville Metro pays a monthly tariff rate for all street lights it has requested and that rate schedule provides LG&E two business days to initiate a repair after notification by a customer.
 - c. See the response to Question No. 25.
 - d. See the response to Question No. 22 d.

LOUISVILLE GAS AND ELECTRIC COMPANY

**Response to First Request for Information of the
Louisville/Jefferson County Metro Government
Dated November 13, 2018**

Case No. 2018-00295

Question No. 30

Responding Witness: John K. Wolfe

- Q-30. Please state how many existing street lights are scheduled (or anticipated) to be replaced by LG&E over the next five years for which the Louisville Metro currently and/or in the future will pay a monthly rate. Please provide the quantity of each type of light being removed and the quantity and type of light that will replace it.
- A-30. LG&E has no scheduled replacements of any current Louisville Metro street lighting fixtures. Street lights on the Restricted Lighting Service rate will be replaced at fixture failure with an equivalent LED. LG&E cannot anticipate the rate at which RLS fixtures will fail and subsequently be replaced with an equivalent LED.

LOUISVILLE GAS AND ELECTRIC COMPANY

**Response to First Request for Information of the
Louisville/Jefferson County Metro Government
Dated November 13, 2018**

Case No. 2018-00295

Question No. 31

Responding Witness: John K. Wolfe

- Q-31. Please state how many existing street lights are scheduled (or anticipated) to be replaced by LG&E over the next five years. Please provide the quantity of each type of light being removed and the quantity and type of light that will replace it.
- A-31. LG&E has no scheduled replacements of any current street lighting fixtures. Street lights on the Restricted Lighting Service rate will be replaced at fixture failure with an equivalent LED. LG&E cannot anticipate the rate at which RLS fixtures will fail and subsequently be replaced with an equivalent LED.

LOUISVILLE GAS AND ELECTRIC COMPANY

**Response to First Request for Information of the
Louisville/Jefferson County Metro Government
Dated November 13, 2018**

Case No. 2018-00295

Question No. 32

Responding Witness: Elizabeth J. McFarland

Q-32. Please refer to the new Green Tariff, Option #2 beginning on proposed tariff Sheet 69:

- a. Will LG&E competitively bid solar installation projects?
- b. Will the system costs and control agreements be available publically?

A-32.

- a. Yes.
- b. No. For competitive reasons the Companies do not publically release the results of competitive bids.

LOUISVILLE GAS AND ELECTRIC COMPANY

**Response to First Request for Information of the
Louisville/Jefferson County Metro Government
Dated November 13, 2018**

Case No. 2018-00295

Question No. 33

Responding Witness: Robert M. Conroy

- Q-33. Please refer to Mr. Conroy's testimony at line 21 of page 21. How does the Company define "reasonable assurance of cost recovery"?
- A-33. The referenced page of the testimony is concerning the Business Solar offering. The Business Solar offering is a contract with a customer seeking to have solar facilities constructed and owned by the Companies. The rates contained in the contract are established to allow the Companies to recover the costs associated with the construction and operation of the facilities from the specific customer.

LOUISVILLE GAS AND ELECTRIC COMPANY

**Response to First Request for Information of the
Louisville/Jefferson County Metro Government
Dated November 13, 2018**

Case No. 2018-00295

Question No. 34

Responding Witness: Robert M. Conroy / Elizabeth J. McFarland

- Q-34. Explain whether LG&E has reviewed all franchises it has with other municipalities to determine whether the proposed tariff changes to the Pole and Structure Attachment Charges- Rate PSA are permissible under every franchise.
- A-34. LG&E has reviewed its franchise agreements with other municipalities to determine whether the proposed tariff changes to the Pole and Structure Attachment Charges- Rate PSA are permissible under those agreements.

LOUISVILLE GAS AND ELECTRIC COMPANY

**Response to First Request for Information of the
Louisville/Jefferson County Metro Government
Dated November 13, 2018**

Case No. 2018-00295

Question No. 35

Responding Witness: John K. Wolfe

Q-35. For each year from 2019 to 2023, how much additional revenue does LG&E anticipate it will receive from the change in the PSA tariff to include governmental units and educational institutions?

A-35. Based upon presently available information, LG&E does not anticipate any additional revenues from the proposed revision in the period from 2019 to 2023. Governmental units and educational institutions that are presently making attachments to LG&E's structures are attaching pursuant to the terms of existing licensing agreements with LG&E. These agreements specify the fees for attachment.

In Case No. 2016-00371, LG&E proposed, and the Commission agreed, that the PSA Rate Schedule should not apply to telecommunication carriers who had existing license agreements to make attachments to LG&E's structures until those license agreements expired. LG&E proposes to extend this approach to Governmental Units and Educational Institutions. Accordingly, the revenues currently paid by Governmental Units and Educational Institutions to attach to LG&E's structures will not change unless the attachment customer elects to terminate its license agreement.

The majority of licensees in this class executed agreements providing for a one-time fee based on the aerial footage of their attachments, rather than the annual, per-attachment fee established in Rate PSA. These agreements expire between 2026 and 2035.

Currently, all licensees in this class who pay an annual, per-attachment fee are paying the same amount as the fee established in Rate PSA.

Until a determination is made in this proceeding regarding Rate PSA's availability to this class of customers, and a pole attachment audit is completed, LG&E will be unable to accurately project pole attachment revenue from this class of customers.

LOUISVILLE GAS AND ELECTRIC COMPANY

**Response to First Request for Information of the
Louisville/Jefferson County Metro Government
Dated November 13, 2018**

Case No. 2018-00295

Question No. 36

Responding Witness: Robert M. Conroy

Q-36. Please refer to line 21 of page 26 of Robert Conroy's testimony.

- a. How many license agreements are currently effective?
- b. How many license agreements will expire in the base period?
- c. How many license agreements will expire in the forecasted test year?

A-36.

- a. LG&E has six license agreements with Governmental Units and Educational Institutions.
- b. None of these agreements will expire in the base period.
- c. If the Commission approves the proposed modifications to the applicability of Rate PSA, one of these agreements will terminate in the forecasted test year. That agreement contains language stating that it will terminate if the Commission approves or modifies LG&E's tariff such that the tariff becomes applicable to the licensee's facilities that are attached to Company structures.

LOUISVILLE GAS AND ELECTRIC COMPANY

**Response to First Request for Information of the
Louisville/Jefferson County Metro Government
Dated November 13, 2018**

Case No. 2018-00295

Question No. 37

Responding Witness: Lonnie E. Bellar

Q-37. Please refer to Exhibit 2 of Lonnie Bellar's testimony, the 2018 RTO Membership Analysis.

- a. For the analysis of the PJM and MISO capacity auction benefits, please provide the estimated clearing prices used for the PJM/MISO auctions for each year in the study (2020-2029).
- b. Please provide the estimated reserve margin required by PJM and MISO for its member utilities.
- c. Please provide the estimated reserve margin for LG&E/KU as provided in its most recent Integrated Resource Plan filed in October, 2018. Were these the margins that KU/LG&E used for purposes of its 2018 RTO Membership Analysis? If not, why not?
- d. Please provide a copy of the work papers for its analysis of the capacity benefits.
- e. Who led the Team that prepared this RTO Membership analysis? Who were the members of the team and what are their positions with the companies?
- f. With respect to its 2012 RTO analysis, did the companies include the loss of load from the municipals in determining its load? Please provide a copy of the 2012 RTO Membership Analysis.

A-37.

- a. See the assumed capacity auction clearing prices in the following table.

Capacity Prices by RTO Planning Year (\$/MW-day)							
	PJM ¹				MISO ²		
	Mid	Low	High		Mid	Low	High
2019/2020	51.33	51.33	51.33		10.00	1.50	72.00
2020/2021	22.96	22.96	22.96		10.00	1.50	72.00
2021/2022	42.00	42.00	42.00		10.00	1.50	72.00
2022/2023	110.11	59.37	164.77		10.00	1.50	72.00
2023/2024	110.11	59.37	164.77		10.00	1.50	72.00
2024/2025	110.11	59.37	164.77		10.00	1.50	72.00
2025/2026	110.11	59.37	164.77		10.00	1.50	72.00
2026/2027	110.11	59.37	164.77		10.00	1.50	72.00
2027/2028	110.11	59.37	164.77		10.00	1.50	72.00
2028/2029	110.11	59.37	164.77		10.00	1.50	72.00
2029/2030	110.11	59.37	164.77		10.00	1.50	72.00

- b. See the Base Residual Auction (BRA) Planning Period Parameter Installed Reserve Margin (IRM) for PJM and the Planning Reserve Margin (PRM) Installed Capacity (ICAP) for MISO for member utilities used in the analysis in the following table.

	PJM IRM ³	MISO PRM ICAP ⁴
2019/2020	16.5%	17.1%
2020/2021	16.6%	17.1%
2021/2022	16.6%	17.1%
2022/2023	16.6%	17.1%
2023/2024	16.6%	17.1%

¹ For all PJM cases year 1 price uses actual average incremental auction value for all RTO. Years 2 and 3 use estimates of average incremental auction values for all RTO. Thereafter, Low Case price constant at 2016/17 auction value (lowest value since 2016/17); Mid Case price constant at average of results for 2016/17-2021/22 auctions; High Case price constant at 2018/19 auction value (highest value since 2016/17). See <https://pjm.com/-/media/markets-ops/rpm/rpm-auction-info/rpm-auctions-resource-clearing-price-summary.ashx?la=en>.

² All prices from MISO Zone 6 auction results. Low Case price constant at 2017/18 auction value (lowest value since 2016/17). Mid Case price constant at last known auction value from 2018/19 auction; High Case price constant at 2016/17 auction value (highest value since 2016/17). See <https://cdn.misoenergy.org/2018-19%20PRA%20Results173180.pdf>

³ PJM BRA planning period parameters available through 2020/2021 at the time of analysis. Thereafter, IRM held constant. See <https://pjm.com/-/media/markets-ops/rpm/rpm-auction-info/2019-2020-rpm-bra-planning-parameters-report.ashx?la=en> and <https://pjm.com/-/media/markets-ops/rpm/rpm-auction-info/2020-2021-rpm-bra-planning-parameters-report.ashx?la=en>.

⁴MISO PRM ICAP data available through 2018/2019 planning period at the time of analysis. Value held constant for entire window of analysis. See <https://cdn.misoenergy.org/20171010%20LOLEWG%20Item%2004a%20Near%20Term%20LOLE%20Results97264.pdf>.

2024/2025	16.6%	17.1%
2025/2026	16.6%	17.1%
2026/2027	16.6%	17.1%
2027/2028	16.6%	17.1%
2028/2029	16.6%	17.1%
2029/2030	16.6%	17.1%

- c. The Companies' 2018 IRP included projected annual planning reserve margins between 23% and 25% through 2033 and a target summer reserve margin range of 17% to 25%. The 2018 RTO Membership Analysis did not use these reserve margins for estimating capacity market value, but instead used the RTOs' installed/planning reserve margin targets shown in the response to part (b). However, the size and composition of the Companies' load and generating fleet assumed in the 2018 RTO Membership Analysis was consistent with the general load and resource supply assumptions that were used to develop the 2018 IRP's projected planning reserve margins.
- d. See attached.
- e. The RTO Analysis was performed by a cross functional team led by Chris Balmer, Director Transmission Strategy and Planning. The following list includes other members of the team and their positions within the Company:
- Daryn Barker, Lead Engineer
 - Kelsey Colvin, Senior Corporate Attorney
 - Jennifer Mulvihill, Manager Compliance
 - Linn Oelker, Manager Market Compliance
 - Mike Sebourn, Manager Generation Planning
 - Jeff Spaulding, Senior Energy Marketing Business Analyst
 - Rosalind Underwood, Lead Planning Analyst
 - Michael Weis, Planning Analyst III

A Steering Team was also created to provide direction, expertise, and experience to the project. The Steering Team consisted of the following employees:

- Robert Conroy, Vice President State Regulation and Rates
- Tom Jessee, Vice President Transmission
- Jennifer Keisling, Director Federal Policy & Senior Counsel
- David Sinclair, Vice President Energy Supply and Analysis

- f. The Companies did not consider the loss of load from the municipals in the 2012 RTO Membership Analysis, as these municipals had not provided a notice of termination under the contract at that time. See attached.

Annual Capacity Value Calculations - MISO

Capacity	ICAP (MW)	Efor _d (%)	EMOR (%)	Delivery Year										
				2019/2020	2020/2021	2021/2022	2022/2023	2023/2024	2024/2025	2025/2026	2026/2027	2027/2028	2028/2029	2029/2030
				UCAP (MW)										
<u>Coal</u>														
Brown 3	409	5.7	2.8	383	383	383	383	383	383	383	383	383	383	383
Ghent 1	475	5.2	2.2	448	448	448	448	448	448	448	448	448	448	448
Ghent 2	485	5.2	2.2	457	457	457	457	457	457	457	457	457	457	457
Ghent 3	481	5.2	2.2	453	453	453	453	453	453	453	453	453	453	453
Ghent 4	478	5.2	2.2	451	451	451	451	451	451	451	451	451	451	451
Mill Creek 1	300	5.2	2.2	283	283	283	283	283	283	283	283	283	283	283
Mill Creek 2	297	5.2	2.2	280	280	280	280	280	280	280	280	280	280	280
Mill Creek 3	391	5.2	2.2	369	369	369	369	369	369	369	369	369	369	369
Mill Creek 4	477	5.2	2.2	450	450	450	450	450	450	450	450	450	450	450
Trimble County 1	370	5.2	2.2	348	348	348	348	348	348	348	348	348	348	348
Trimble County 2	549	9.3	3.8	493	493	493	493	493	493	493	493	493	493	493
OVEC	172	5.7	2.8	161	161	161	161	161	161	161	161	161	161	161
<u>NGCC</u>														
Cane Run 7	662	3.0	5.9	632	632	632	632	632	632	632	632	632	632	632
<u>Peaking</u>														
Brown 5	130	9.9		117	117	117	117	117	117	117	117	117	117	117
Brown 6	146	9.9		132	132	132	132	132	132	132	132	132	132	132
Brown 7	146	9.9		132	132	132	132	132	132	132	132	132	132	132
Brown 8	121	9.9		109	109	109	109	109	109	109	109	109	109	109
Brown 9	121	9.9		109	109	109	109	109	109	109	109	109	109	109
Brown 10	121	9.9		109	109	109	109	109	109	109	109	109	109	109
Brown 11	121	9.9		109	109	109	109	109	109	109	109	109	109	109
Trimble County 5	159	5.7		150	150	150	150	150	150	150	150	150	150	150
Trimble County 6	159	5.7		150	150	150	150	150	150	150	150	150	150	150
Trimble County 7	159	5.7		150	150	150	150	150	150	150	150	150	150	150
Trimble County 8	159	5.7		150	150	150	150	150	150	150	150	150	150	150
Trimble County 9	159	5.7		150	150	150	150	150	150	150	150	150	150	150
Trimble County 10	159	5.7		150	150	150	150	150	150	150	150	150	150	150
Paddy's Run 13	147	9.9		132	132	132	132	132	132	132	132	132	132	132
<u>Solar</u>														
Brown Solar	10			4	4	4	4	4	4	4	4	4	4	4
<u>Hydro</u>														
Dix Dam 1	11			10.5	10.5	10.5	10.5	10.5	10.5	10.5	10.5	10.5	10.5	10.5
Dix Dam 2	11			10.5	10.5	10.5	10.5	10.5	10.5	10.5	10.5	10.5	10.5	10.5
Dix Dam 3	11			10.5	10.5	10.5	10.5	10.5	10.5	10.5	10.5	10.5	10.5	10.5
Ohio Falls 1	12			6.5	6.5	6.5	6.5	6.5	6.5	6.5	6.5	6.5	6.5	6.5
Ohio Falls 2	12			6.5	6.5	6.5	6.5	6.5	6.5	6.5	6.5	6.5	6.5	6.5
Ohio Falls 3	12			6.5	6.5	6.5	6.5	6.5	6.5	6.5	6.5	6.5	6.5	6.5
Ohio Falls 4	12			6.5	6.5	6.5	6.5	6.5	6.5	6.5	6.5	6.5	6.5	6.5
Ohio Falls 5	12			6.5	6.5	6.5	6.5	6.5	6.5	6.5	6.5	6.5	6.5	6.5
Ohio Falls 6	12			6.5	6.5	6.5	6.5	6.5	6.5	6.5	6.5	6.5	6.5	6.5

Annual Capacity Value Calculations - MISO

			Delivery Year										
			2019/2020	2020/2021	2021/2022	2022/2023	2023/2024	2024/2025	2025/2026	2026/2027	2027/2028	2028/2029	2029/2030
Ohio Falls 7	12		6.5	6.5	6.5	6.5	6.5	6.5	6.5	6.5	6.5	6.5	6.5
Ohio Falls 8	12		6.5	6.5	6.5	6.5	6.5	6.5	6.5	6.5	6.5	6.5	6.5
	7,690		7,143	7,143	7,143	7,143	7,143	7,143	7,143	7,143	7,143	7,143	7,143
Capacity Available for Auction													
Mid			7,143	7,143	7,143	7,143	7,143	7,143	7,143	7,143	7,143	7,143	7,143
Low			7,143	7,143	7,143	7,143	7,143	7,143	7,143	7,143	7,143	7,143	7,143
High			7,143	7,143	7,143	7,143	7,143	7,143	7,143	7,143	7,143	7,143	7,143
Load (MW)													
Summer Peak (Planning Calendar)			6,361	6,350	6,338	6,338	6,325	6,330	6,344	6,352	6,351	6,357	6,355
Historical Avg Ratio of MISO Coincidence Factor	0.97												
Forecasted 5 CP Average (Planning Calendar)			6,174	6,164	6,152	6,152	6,140	6,145	6,158	6,165	6,165	6,170	6,168
Capacity Need			6,827	6,816	6,802	6,802	6,789	6,794	6,809	6,817	6,817	6,823	6,820
Capacity Cleared in Auction													
Mid			316	327	341	341	354	349	334	326	326	320	322
Low			316	327	341	341	354	349	334	326	326	320	322
High			316	327	341	341	354	349	334	326	326	320	322
Net Capacity for Auction			316	327	341	341	354	349	334	326	326	320	322
Capacity Performance Resource Clearing Price (\$/MW-Day)													
Mid Case			10.00	10.00	10.00	10.00	10.00	10.00	10.00	10.00	10.00	10.00	10.00
Low Case			1.50	1.50	1.50	1.50	1.50	1.50	1.50	1.50	1.50	1.50	1.50
High Case			72.00	72.00	72.00	72.00	72.00	72.00	72.00	72.00	72.00	72.00	72.00
RPM Auction - Capacity Credit (\$)													
Mid Case			1	1	1	1	1	1	1	1	1	1	13
Low Case			0	0	0	0	0	0	0	0	0	0	2
High Case			8	9	9	9	9	9	9	9	9	8	96

Annual Capacity Value Calculations - MISO

<u>Assumptions</u>	<u>Delivery Year</u>												
	2019/2020	2020/2021	2021/2022	2022/2023	2023/2024	2024/2025	2025/2026	2026/2027	2027/2028	2028/2029	2029/2030		
ICAP based PRM _{RTO}	17.10%	17.10%	17.10%	17.10%	17.10%	17.10%	17.10%	17.10%	17.10%	17.10%	17.10%	17.10%	
MISO System XEFORd	7.54%	7.54%	7.54%	7.54%	7.54%	7.54%	7.54%	7.54%	7.54%	7.54%	7.54%	7.54%	
Transmission Loss	2.00%	2.00%	2.00%	2.00%	2.00%	2.00%	2.00%	2.00%	2.00%	2.00%	2.00%	2.00%	
UCAP based PRM _{RTO}	8.40%	8.40%	8.40%	8.40%	8.40%	8.40%	8.40%	8.40%	8.40%	8.40%	8.40%	8.40%	
Capacity Performance Resource Clearing Price (\$/MW-Day) Calendar Year	2019	2020	2021	2022	2023	2024	2025	2026	2027	2028	2029	2030	
RPM Auction - Capacity Credit (\$)													
Mid Case	0.0	1.2	1.2	1.2	1.3	1.3	1.2	1.2	1.2	1.2	1.2	0.5	13
Low Case	0.0	0.2	0.2	0.2	0.2	0.2	0.2	0.2	0.2	0.2	0.2	0.1	2
High Case	4.9	8.5	8.8	9.0	9.2	9.2	8.9	8.6	8.6	8.5	8.4	3.5	96

UCAP

MOR is weighted 25% in UCAP calculation.

Capacity

Mid Case = Values based upon actual prices from auction results with UCAP credit held constant from last available planning year of 2018/2019.

Low Case = lowest observed price for planning years 2014/2015-2018/2019.

High Case = Values from interpolating between last available auction result for All RTO for 2018/2019 with CONE for 2018/2019 auction for Zone 6 assumed for 2029/2030 planning year.

Cleared Capacity Assumptions - MISO

Cleared UCAP

	Delivery Year											
	2019/2020	2020/2021	2021/2022	2022/2023	2023/2024	2024/2025	2025/2026	2026/2027	2027/2028	2028/2029	2029/2030	
Base UCAP												
Coal	4,574	4,574	4,574	4,574	4,574	4,574	4,574	4,574	4,574	4,574	4,574	4,574
Gas	2,481	2,481	2,481	2,481	2,481	2,481	2,481	2,481	2,481	2,481	2,481	2,481
Hydro	84	84	84	84	84	84	84	84	84	84	84	84
Solar	4	4	4	4	4	4	4	4	4	4	4	4
Total	7,143	7,143	7,143	7,143	7,143	7,143	7,143	7,143	7,143	7,143	7,143	7,143

Mid

Clearance Rate

Coal	0.0%	100.0%	0	4,574	4,574	4,574	4,574	4,574	4,574	4,574	4,574	4,574	4,574
Gas	0.0%	100.0%	0	2,481	2,481	2,481	2,481	2,481	2,481	2,481	2,481	2,481	2,481
Hydro	0.0%	100.0%	0	84	84	84	84	84	84	84	84	84	84
Solar	0.0%	100.0%	0	4	4	4	4	4	4	4	4	4	4
Total Mid				7,143	7,143	7,143	7,143	7,143	7,143	7,143	7,143	7,143	7,143

Low

Coal	0.0%	100.0%		4,574	4,574	4,574	4,574	4,574	4,574	4,574	4,574	4,574	4,574
Gas	0.0%	100.0%		2,481	2,481	2,481	2,481	2,481	2,481	2,481	2,481	2,481	2,481
Hydro	0.0%	100.0%		84	84	84	84	84	84	84	84	84	84
Solar	0.0%	100.0%		4	4	4	4	4	4	4	4	4	4
Total				7,143	7,143	7,143	7,143	7,143	7,143	7,143	7,143	7,143	7,143

High

Coal	0.0%	100.0%		4,574	4,574	4,574	4,574	4,574	4,574	4,574	4,574	4,574	4,574
Gas	0.0%	100.0%		2,481	2,481	2,481	2,481	2,481	2,481	2,481	2,481	2,481	2,481
Hydro	0.0%	100.0%		84	84	84	84	84	84	84	84	84	84
Solar	0.0%	100.0%		4	4	4	4	4	4	4	4	4	4
Total				7,143	7,143	7,143	7,143	7,143	7,143	7,143	7,143	7,143	7,143

Days for Calendar Year Calculation

<u>Days</u>	
1/1/2017	
6/1/2017	151
1/1/2018	214
6/1/2018	151
1/1/2019	214
6/1/2019	151
1/1/2020	214
6/1/2020	152
1/1/2021	214
6/1/2021	151
1/1/2022	214
6/1/2022	151
1/1/2023	214
6/1/2023	151
1/1/2024	214
6/1/2024	152
1/1/2025	214
6/1/2025	151
1/1/2026	214
6/1/2026	151
1/1/2027	214
6/1/2027	151
1/1/2028	214
6/1/2028	152
1/1/2029	214
6/1/2029	151
1/1/2030	214
6/1/2030	151

Combined Company Coincident Peaks

Year	<u>MISO Peak</u>			LKE Load	Average 5 CP	<u>LKE Summer Peak,vg CP / Peak Ratio</u>	
	Hour Rank	5 CP	HE				Peak Ratio
2012	1	6/28/2012	17	6,477	2012	6,431	6,856 94%
2012	2	7/25/2012	17	6,761	2013	6,067	6,409 95%
2012	3	8/8/2012	16	6,586	2014	6,229	6,313 99%
2012	4	9/4/2012	16	5,900	2015	6,132	6,392 96%
					2016	6,269	6,458 97% Normal Weather
					2017	6,127	6,503 94%
2013	1	7/18/2013	16	5,967			
2013	2	7/18/2013	17	5,976		Average	96%
2013	3	7/18/2013	15	6,117			
2013	4	7/17/2013	17	6,133			
2013	5	7/18/2013	14	6,140			
2014	1	7/22/2014	17	6,288			
2014	2	8/25/2014	15	6,214			
2014	3	8/25/2014	16	6,208			
2014	4	7/22/2014	16	6,267			
2014	5	8/25/2014	17	6,166			
2015	1	7/28/2015	16	6,079			
2015	2	7/28/2015	15	6,244			
2015	3	7/28/2015	17	5,912			
2015	4	7/27/2015	16	6,293			
2015	5	7/27/2015	17	6,133			
2016	1	7/21/2016	16	6,264			
2016	2	7/21/2016	15	6,267			
2016	3	7/21/2016	17	6,241			
2016	4	7/21/2016	14	6,224			
2016	5	8/10/2016	16	6,350			
2017	1	7/20/2017	17	6,202			
2017	2	7/20/2017	18	6,023			
2017	3	7/20/2017	16	6,278			
2017	4	7/20/2017	15	6,303			
2017	5	7/20/2017	19	5,826			

Combined Company Load Data

	Planning Year										
	<u>2019/2020</u>	<u>2020/2021</u>	<u>2021/2022</u>	<u>2022/2023</u>	<u>2023/2024</u>	<u>2024/2025</u>	<u>2025/2026</u>	<u>2026/2027</u>	<u>2027/2028</u>	<u>2028/2029</u>	<u>2029/2030</u>
Peak Load (MW)	6,361	6,350	6,338	6,338	6,325	6,330	6,344	6,352	6,351	6,357	6,355

Historical Load

Day	Hr	Total	Year	Month
1/1/2012	0	3078.66	2012	1
1/1/2012	1	3035.163	2012	1
1/1/2012	2	2886.529	2012	1
1/1/2012	3	2891.329	2012	1
1/1/2012	4	2833.363	2012	1
1/1/2012	5	2855.362	2012	1
1/1/2012	6	2801.254	2012	1
1/1/2012	7	2924.753	2012	1
1/1/2012	8	2929.763	2012	1
1/1/2012	9	3035.663	2012	1
1/1/2012	10	3108.362	2012	1
1/1/2012	11	3139.863	2012	1
1/1/2012	12	3217.962	2012	1
1/1/2012	13	3249.451	2012	1
1/1/2012	14	3206.057	2012	1
1/1/2012	15	3246.362	2012	1
1/1/2012	16	3254.363	2012	1
1/1/2012	17	3512.263	2012	1
1/1/2012	18	3786.762	2012	1
1/1/2012	19	3824.456	2012	1
1/1/2012	20	3842.05	2012	1
1/1/2012	21	3804.362	2012	1
1/1/2012	22	3683.463	2012	1
1/1/2012	23	3533.662	2012	1
1/2/2012	0	3407.662	2012	1
1/2/2012	1	3391.854	2012	1
1/2/2012	2	3346.952	2012	1
1/2/2012	3	3458.462	2012	1
1/2/2012	4	3523.661	2012	1
1/2/2012	5	3699.862	2012	1
1/2/2012	6	3965.957	2012	1
1/2/2012	7	4180.449	2012	1
1/2/2012	8	4264.962	2012	1
1/2/2012	9	4411.662	2012	1
1/2/2012	10	4582.063	2012	1
1/2/2012	11	4635.95	2012	1
1/2/2012	12	4706.856	2012	1
1/2/2012	13	4731.362	2012	1
1/2/2012	14	4724.562	2012	1
1/2/2012	15	4728.956	2012	1
1/2/2012	16	4798.65	2012	1
1/2/2012	17	5020.962	2012	1
1/2/2012	18	5157.56	2012	1
1/2/2012	19	5220.815	2012	1
1/2/2012	20	5138.245	2012	1
1/2/2012	21	5007.361	2012	1
1/2/2012	22	4845.96	2012	1
1/2/2012	23	4649.961	2012	1
1/3/2012	0	4583.645	2012	1
1/3/2012	1	4454.258	2012	1
1/3/2012	2	4459.56	2012	1
1/3/2012	3	4468.66	2012	1
1/3/2012	4	4520.744	2012	1
1/3/2012	5	4808.057	2012	1

Day	Hr	Total	Year	Month
1/3/2012	6	5195.138	2012	1
1/3/2012	7	5473.161	2012	1
1/3/2012	8	5473.646	2012	1
1/3/2012	9	5409.16	2012	1
1/3/2012	10	5278.861	2012	1
1/3/2012	11	5149.561	2012	1
1/3/2012	12	5047.722	2012	1
1/3/2012	13	5001.549	2012	1
1/3/2012	14	4897.26	2012	1
1/3/2012	15	4732.756	2012	1
1/3/2012	16	4786.158	2012	1
1/3/2012	17	5081.151	2012	1
1/3/2012	18	5299.656	2012	1
1/3/2012	19	5295.661	2012	1
1/3/2012	20	5291.761	2012	1
1/3/2012	21	5136.661	2012	1
1/3/2012	22	4933.349	2012	1
1/3/2012	23	4736.757	2012	1
1/4/2012	0	4597.261	2012	1
1/4/2012	1	4513.961	2012	1
1/4/2012	2	4453.262	2012	1
1/4/2012	3	4410.444	2012	1
1/4/2012	4	4482.66	2012	1
1/4/2012	5	4712.96	2012	1
1/4/2012	6	5104.161	2012	1
1/4/2012	7	5358.056	2012	1
1/4/2012	8	5304.05	2012	1
1/4/2012	9	5169.961	2012	1
1/4/2012	10	5070.963	2012	1
1/4/2012	11	4884.562	2012	1
1/4/2012	12	4793.449	2012	1
1/4/2012	13	4687.957	2012	1
1/4/2012	14	4464.857	2012	1
1/4/2012	15	4383.662	2012	1
1/4/2012	16	4317.062	2012	1
1/4/2012	17	4487.363	2012	1
1/4/2012	18	4782.448	2012	1
1/4/2012	19	4759.959	2012	1
1/4/2012	20	4764.461	2012	1
1/4/2012	21	4603.82	2012	1
1/4/2012	22	4363.362	2012	1
1/4/2012	23	4145.861	2012	1
1/5/2012	0	3949.846	2012	1
1/5/2012	1	3915.46	2012	1
1/5/2012	2	3875.461	2012	1
1/5/2012	3	3920.162	2012	1
1/5/2012	4	3951.361	2012	1
1/5/2012	5	4148.452	2012	1
1/5/2012	6	4640.254	2012	1
1/5/2012	7	5004.562	2012	1
1/5/2012	8	4969.162	2012	1
1/5/2012	9	4842.262	2012	1
1/5/2012	10	4635.255	2012	1
1/5/2012	11	4406.052	2012	1
1/5/2012	12	4359.363	2012	1
1/5/2012	13	4225.162	2012	1
1/5/2012	14	4106.462	2012	1
1/5/2012	15	3987.463	2012	1
1/5/2012	16	4014.163	2012	1
1/5/2012	17	4129.551	2012	1
1/5/2012	18	4454.757	2012	1
1/5/2012	19	4418.562	2012	1
1/5/2012	20	4447.562	2012	1
1/5/2012	21	4274.961	2012	1

Day	Hr	Total	Year	Month
1/5/2012	22	4020.562	2012	1
1/5/2012	23	3911.662	2012	1
1/6/2012	0	3724.045	2012	1
1/6/2012	1	3615.461	2012	1
1/6/2012	2	3619.062	2012	1
1/6/2012	3	3528.662	2012	1
1/6/2012	4	3530.961	2012	1
1/6/2012	5	3793.762	2012	1
1/6/2012	6	4170.549	2012	1
1/6/2012	7	4489.957	2012	1
1/6/2012	8	4462.363	2012	1
1/6/2012	9	4337.962	2012	1
1/6/2012	10	4216.563	2012	1
1/6/2012	11	4071.163	2012	1
1/6/2012	12	3995.062	2012	1
1/6/2012	13	3855.647	2012	1
1/6/2012	14	3773.263	2012	1
1/6/2012	15	3671.362	2012	1
1/6/2012	16	3607.663	2012	1
1/6/2012	17	3720.063	2012	1
1/6/2012	18	3924.962	2012	1
1/6/2012	19	3897.762	2012	1
1/6/2012	20	3878.862	2012	1
1/6/2012	21	3841.248	2012	1
1/6/2012	22	3647.858	2012	1
1/6/2012	23	3502.962	2012	1
1/7/2012	0	3320.962	2012	1
1/7/2012	1	3224.262	2012	1
1/7/2012	2	3086.362	2012	1
1/7/2012	3	2999.761	2012	1
1/7/2012	4	2953.462	2012	1
1/7/2012	5	3028.854	2012	1
1/7/2012	6	3086.252	2012	1
1/7/2012	7	3269.162	2012	1
1/7/2012	8	3373.062	2012	1
1/7/2012	9	3428.062	2012	1
1/7/2012	10	3423.063	2012	1
1/7/2012	11	3448.062	2012	1
1/7/2012	12	3430.462	2012	1
1/7/2012	13	3343.755	2012	1
1/7/2012	14	3287.452	2012	1
1/7/2012	15	3210.063	2012	1
1/7/2012	16	3232.462	2012	1
1/7/2012	17	3458.963	2012	1
1/7/2012	18	3697.462	2012	1
1/7/2012	19	3717.061	2012	1
1/7/2012	20	3707.262	2012	1
1/7/2012	21	3694.259	2012	1
1/7/2012	22	3567.246	2012	1
1/7/2012	23	3493.862	2012	1
1/8/2012	0	3359.962	2012	1
1/8/2012	1	3282.561	2012	1
1/8/2012	2	3273.961	2012	1
1/8/2012	3	3351.062	2012	1
1/8/2012	4	3360.855	2012	1
1/8/2012	5	3492.849	2012	1
1/8/2012	6	3587.361	2012	1
1/8/2012	7	3769.709	2012	1
1/8/2012	8	3878.062	2012	1
1/8/2012	9	3898.062	2012	1
1/8/2012	10	3781.647	2012	1
1/8/2012	11	3591.561	2012	1
1/8/2012	12	3547.262	2012	1
1/8/2012	13	3474.062	2012	1

Day	Hr	Total	Year	Month
1/8/2012	14	3400.263	2012	1
1/8/2012	15	3365.025	2012	1
1/8/2012	16	3359.75	2012	1
1/8/2012	17	3592.86	2012	1
1/8/2012	18	3865.162	2012	1
1/8/2012	19	3894.762	2012	1
1/8/2012	20	3855.362	2012	1
1/8/2012	21	3758.46	2012	1
1/8/2012	22	3617.547	2012	1
1/8/2012	23	3466.362	2012	1
1/9/2012	0	3339.962	2012	1
1/9/2012	1	3305.962	2012	1
1/9/2012	2	3246.862	2012	1
1/9/2012	3	3281.55	2012	1
1/9/2012	4	3340.555	2012	1
1/9/2012	5	3590.862	2012	1
1/9/2012	6	4053.362	2012	1
1/9/2012	7	4382.462	2012	1
1/9/2012	8	4417.457	2012	1
1/9/2012	9	4425.742	2012	1
1/9/2012	10	4417.357	2012	1
1/9/2012	11	4346.558	2012	1
1/9/2012	12	4202.658	2012	1
1/9/2012	13	4065.657	2012	1
1/9/2012	14	4048.157	2012	1
1/9/2012	15	3928.058	2012	1
1/9/2012	16	3833.046	2012	1
1/9/2012	17	4092.163	2012	1
1/9/2012	18	4353.562	2012	1
1/9/2012	19	4336.963	2012	1
1/9/2012	20	4337.362	2012	1
1/9/2012	21	4249.987	2012	1
1/9/2012	22	4074.662	2012	1
1/9/2012	23	3868.648	2012	1
1/10/2012	0	3762.859	2012	1
1/10/2012	1	3709.162	2012	1
1/10/2012	2	3689.762	2012	1
1/10/2012	3	3660.362	2012	1
1/10/2012	4	3769.462	2012	1
1/10/2012	5	4008.357	2012	1
1/10/2012	6	4454.15	2012	1
1/10/2012	7	4749.162	2012	1
1/10/2012	8	4732.862	2012	1
1/10/2012	9	4613.662	2012	1
1/10/2012	10	4501.463	2012	1
1/10/2012	11	4340.862	2012	1
1/10/2012	12	4212.65	2012	1
1/10/2012	13	4112.358	2012	1
1/10/2012	14	4041.063	2012	1
1/10/2012	15	3907.563	2012	1
1/10/2012	16	3903.363	2012	1
1/10/2012	17	3997.562	2012	1
1/10/2012	18	4352.763	2012	1
1/10/2012	19	4340.262	2012	1
1/10/2012	20	4269.651	2012	1
1/10/2012	21	4213.555	2012	1
1/10/2012	22	4002.562	2012	1
1/10/2012	23	3782.762	2012	1
1/11/2012	0	3606.262	2012	1
1/11/2012	1	3469.062	2012	1
1/11/2012	2	3416.861	2012	1
1/11/2012	3	3418.746	2012	1
1/11/2012	4	3464.261	2012	1
1/11/2012	5	3579.262	2012	1

Day	Hr	Total	Year	Month
1/11/2012	6	3982.762	2012	1
1/11/2012	7	4301.162	2012	1
1/11/2012	8	4313.956	2012	1
1/11/2012	9	4282.651	2012	1
1/11/2012	10	4256.963	2012	1
1/11/2012	11	4248.563	2012	1
1/11/2012	12	4258.362	2012	1
1/11/2012	13	4180.463	2012	1
1/11/2012	14	4090.962	2012	1
1/11/2012	15	4030.25	2012	1
1/11/2012	16	4022.459	2012	1
1/11/2012	17	4136.162	2012	1
1/11/2012	18	4283.262	2012	1
1/11/2012	19	4238.462	2012	1
1/11/2012	20	4193.262	2012	1
1/11/2012	21	4009.762	2012	1
1/11/2012	22	3803.452	2012	1
1/11/2012	23	3591.754	2012	1
1/12/2012	0	3459.962	2012	1
1/12/2012	1	3427.362	2012	1
1/12/2012	2	3310.862	2012	1
1/12/2012	3	3296.962	2012	1
1/12/2012	4	3316.462	2012	1
1/12/2012	5	3454.952	2012	1
1/12/2012	6	3934.355	2012	1
1/12/2012	7	4242.362	2012	1
1/12/2012	8	4275.163	2012	1
1/12/2012	9	4300.262	2012	1
1/12/2012	10	4328.463	2012	1
1/12/2012	11	4364.444	2012	1
1/12/2012	12	4441.046	2012	1
1/12/2012	13	4497.66	2012	1
1/12/2012	14	4520.662	2012	1
1/12/2012	15	4606.361	2012	1
1/12/2012	16	4745.662	2012	1
1/12/2012	17	4982.546	2012	1
1/12/2012	18	5174.858	2012	1
1/12/2012	19	5200.961	2012	1
1/12/2012	20	5201.162	2012	1
1/12/2012	21	5032.155	2012	1
1/12/2012	22	4878.247	2012	1
1/12/2012	23	4766.761	2012	1
1/13/2012	0	4699.06	2012	1
1/13/2012	1	4677.16	2012	1
1/13/2012	2	4705.745	2012	1
1/13/2012	3	4702.758	2012	1
1/13/2012	4	4808.661	2012	1
1/13/2012	5	4994.26	2012	1
1/13/2012	6	5318.948	2012	1
1/13/2012	7	5614.155	2012	1
1/13/2012	8	5657.581	2012	1
1/13/2012	9	5704.361	2012	1
1/13/2012	10	5694.25	2012	1
1/13/2012	11	5655.255	2012	1
1/13/2012	12	5636.361	2012	1
1/13/2012	13	5568.219	2012	1
1/13/2012	14	5475.454	2012	1
1/13/2012	15	5421.951	2012	1
1/13/2012	16	5336.562	2012	1
1/13/2012	17	5420.061	2012	1
1/13/2012	18	5467.159	2012	1
1/13/2012	19	5321.446	2012	1
1/13/2012	20	5258.461	2012	1
1/13/2012	21	5101.161	2012	1

Day	Hr	Total	Year	Month
1/13/2012	22	4924.962	2012	1
1/13/2012	23	4679.348	2012	1
1/14/2012	0	4547.956	2012	1
1/14/2012	1	4473.576	2012	1
1/14/2012	2	4450.261	2012	1
1/14/2012	3	4419.454	2012	1
1/14/2012	4	4468.551	2012	1
1/14/2012	5	4543.761	2012	1
1/14/2012	6	4698.461	2012	1
1/14/2012	7	4863.357	2012	1
1/14/2012	8	4920.448	2012	1
1/14/2012	9	4919.562	2012	1
1/14/2012	10	4775.261	2012	1
1/14/2012	11	4680.562	2012	1
1/14/2012	12	4485.849	2012	1
1/14/2012	13	4336.558	2012	1
1/14/2012	14	4236.762	2012	1
1/14/2012	15	4232.062	2012	1
1/14/2012	16	4240.362	2012	1
1/14/2012	17	4452.146	2012	1
1/14/2012	18	4602.96	2012	1
1/14/2012	19	4595.161	2012	1
1/14/2012	20	4524.162	2012	1
1/14/2012	21	4422.06	2012	1
1/14/2012	22	4249.745	2012	1
1/14/2012	23	4072.961	2012	1
1/15/2012	0	3987.762	2012	1
1/15/2012	1	3916.061	2012	1
1/15/2012	2	3888.657	2012	1
1/15/2012	3	3851.949	2012	1
1/15/2012	4	3891.461	2012	1
1/15/2012	5	3992.261	2012	1
1/15/2012	6	4105.061	2012	1
1/15/2012	7	4246.052	2012	1
1/15/2012	8	4365.554	2012	1
1/15/2012	9	4390.662	2012	1
1/15/2012	10	4322.861	2012	1
1/15/2012	11	4190.562	2012	1
1/15/2012	12	4083.951	2012	1
1/15/2012	13	3965.757	2012	1
1/15/2012	14	3825.762	2012	1
1/15/2012	15	3688.363	2012	1
1/15/2012	16	3755.454	2012	1
1/15/2012	17	3994.457	2012	1
1/15/2012	18	4325.85	2012	1
1/15/2012	19	4388.561	2012	1
1/15/2012	20	4385.562	2012	1
1/15/2012	21	4353.061	2012	1
1/15/2012	22	4224.36	2012	1
1/15/2012	23	4058.545	2012	1
1/16/2012	0	3979.962	2012	1
1/16/2012	1	3885.261	2012	1
1/16/2012	2	3820.961	2012	1
1/16/2012	3	3879.56	2012	1
1/16/2012	4	3888.946	2012	1
1/16/2012	5	4022.562	2012	1
1/16/2012	6	4250.961	2012	1
1/16/2012	7	4491.762	2012	1
1/16/2012	8	4540.162	2012	1
1/16/2012	9	4578.847	2012	1
1/16/2012	10	4589.76	2012	1
1/16/2012	11	4552.763	2012	1
1/16/2012	12	4574.162	2012	1
1/16/2012	13	4528.362	2012	1

Day	Hr	Total	Year	Month
1/16/2012	14	4486.958	2012	1
1/16/2012	15	4405.15	2012	1
1/16/2012	16	4334.762	2012	1
1/16/2012	17	4430.962	2012	1
1/16/2012	18	4469.962	2012	1
1/16/2012	19	4412.962	2012	1
1/16/2012	20	4307.862	2012	1
1/16/2012	21	4110.348	2012	1
1/16/2012	22	3855.959	2012	1
1/16/2012	23	3605.262	2012	1
1/17/2012	0	3421.763	2012	1
1/17/2012	1	3288.661	2012	1
1/17/2012	2	3209.262	2012	1
1/17/2012	3	3239.161	2012	1
1/17/2012	4	3156.546	2012	1
1/17/2012	5	3306.162	2012	1
1/17/2012	6	3642.962	2012	1
1/17/2012	7	4018.062	2012	1
1/17/2012	8	4025.563	2012	1
1/17/2012	9	3983.562	2012	1
1/17/2012	10	4011.063	2012	1
1/17/2012	11	3982.754	2012	1
1/17/2012	12	4064.954	2012	1
1/17/2012	13	4002.062	2012	1
1/17/2012	14	3903.762	2012	1
1/17/2012	15	3951.363	2012	1
1/17/2012	16	4018.262	2012	1
1/17/2012	17	4217.462	2012	1
1/17/2012	18	4460.251	2012	1
1/17/2012	19	4492.978	2012	1
1/17/2012	20	4469.362	2012	1
1/17/2012	21	4397.561	2012	1
1/17/2012	22	4215.262	2012	1
1/17/2012	23	4061.061	2012	1
1/18/2012	0	3900.052	2012	1
1/18/2012	1	3831.153	2012	1
1/18/2012	2	3785.062	2012	1
1/18/2012	3	3788.761	2012	1
1/18/2012	4	3909.062	2012	1
1/18/2012	5	4112.462	2012	1
1/18/2012	6	4538.746	2012	1
1/18/2012	7	4881.859	2012	1
1/18/2012	8	4914.662	2012	1
1/18/2012	9	4900.462	2012	1
1/18/2012	10	4881.362	2012	1
1/18/2012	11	4759.555	2012	1
1/18/2012	12	4705.852	2012	1
1/18/2012	13	4624.263	2012	1
1/18/2012	14	4524.262	2012	1
1/18/2012	15	4443.363	2012	1
1/18/2012	16	4407.062	2012	1
1/18/2012	17	4610.757	2012	1
1/18/2012	18	4926.45	2012	1
1/18/2012	19	4964.962	2012	1
1/18/2012	20	4977.761	2012	1
1/18/2012	21	4851.562	2012	1
1/18/2012	22	4682.261	2012	1
1/18/2012	23	4501.649	2012	1
1/19/2012	0	4328.157	2012	1
1/19/2012	1	4284.861	2012	1
1/19/2012	2	4281.861	2012	1
1/19/2012	3	4291.262	2012	1
1/19/2012	4	4380.554	2012	1
1/19/2012	5	4592.851	2012	1

Day	Hr	Total	Year	Month
1/19/2012	6	5006.961	2012	1
1/19/2012	7	5260.762	2012	1
1/19/2012	8	5180.962	2012	1
1/19/2012	9	5085.155	2012	1
1/19/2012	10	4940.251	2012	1
1/19/2012	11	4870.474	2012	1
1/19/2012	12	4771.762	2012	1
1/19/2012	13	4662.162	2012	1
1/19/2012	14	4577.862	2012	1
1/19/2012	15	4419.948	2012	1
1/19/2012	16	4412.248	2012	1
1/19/2012	17	4585.662	2012	1
1/19/2012	18	4744.862	2012	1
1/19/2012	19	4763.662	2012	1
1/19/2012	20	4772.462	2012	1
1/19/2012	21	4704.246	2012	1
1/19/2012	22	4463.06	2012	1
1/19/2012	23	4282.661	2012	1
1/20/2012	0	4162.661	2012	1
1/20/2012	1	4033.462	2012	1
1/20/2012	2	4017.346	2012	1
1/20/2012	3	4020.759	2012	1
1/20/2012	4	4066.061	2012	1
1/20/2012	5	4285.661	2012	1
1/20/2012	6	4641.459	2012	1
1/20/2012	7	4953.747	2012	1
1/20/2012	8	4966.361	2012	1
1/20/2012	9	5023.862	2012	1
1/20/2012	10	4965.962	2012	1
1/20/2012	11	4870.054	2012	1
1/20/2012	12	4772.853	2012	1
1/20/2012	13	4701.862	2012	1
1/20/2012	14	4622.862	2012	1
1/20/2012	15	4572.662	2012	1
1/20/2012	16	4550.155	2012	1
1/20/2012	17	4586.552	2012	1
1/20/2012	18	4642.962	2012	1
1/20/2012	19	4539.961	2012	1
1/20/2012	20	4467.562	2012	1
1/20/2012	21	4322.659	2012	1
1/20/2012	22	4072.247	2012	1
1/20/2012	23	3895.462	2012	1
1/21/2012	0	3721.662	2012	1
1/21/2012	1	3599.061	2012	1
1/21/2012	2	3536.763	2012	1
1/21/2012	3	3539.947	2012	1
1/21/2012	4	3594.459	2012	1
1/21/2012	5	3669.462	2012	1
1/21/2012	6	3818.762	2012	1
1/21/2012	7	4060.461	2012	1
1/21/2012	8	4211.051	2012	1
1/21/2012	9	4388.856	2012	1
1/21/2012	10	4488.862	2012	1
1/21/2012	11	4514.262	2012	1
1/21/2012	12	4450.434	2012	1
1/21/2012	13	4408.05	2012	1
1/21/2012	14	4396.256	2012	1
1/21/2012	15	4386.062	2012	1
1/21/2012	16	4361.462	2012	1
1/21/2012	17	4519.462	2012	1
1/21/2012	18	4678.955	2012	1
1/21/2012	19	4635.759	2012	1
1/21/2012	20	4538.662	2012	1
1/21/2012	21	4423.061	2012	1

Day	Hr	Total	Year	Month
1/21/2012	22	4278.556	2012	1
1/21/2012	23	4097.949	2012	1
1/22/2012	0	3917.862	2012	1
1/22/2012	1	3768.361	2012	1
1/22/2012	2	3732.061	2012	1
1/22/2012	3	3646.152	2012	1
1/22/2012	4	3730.654	2012	1
1/22/2012	5	3753.361	2012	1
1/22/2012	6	3851.162	2012	1
1/22/2012	7	3889.962	2012	1
1/22/2012	8	3985.55	2012	1
1/22/2012	9	4128.357	2012	1
1/22/2012	10	4082.162	2012	1
1/22/2012	11	3964.762	2012	1
1/22/2012	12	3893.862	2012	1
1/22/2012	13	3809.154	2012	1
1/22/2012	14	3713.154	2012	1
1/22/2012	15	3639.162	2012	1
1/22/2012	16	3615.062	2012	1
1/22/2012	17	3714.563	2012	1
1/22/2012	18	3852.061	2012	1
1/22/2012	19	3815.956	2012	1
1/22/2012	20	3740.051	2012	1
1/22/2012	21	3585.462	2012	1
1/22/2012	22	3413.063	2012	1
1/22/2012	23	3219.762	2012	1
1/23/2012	0	3010.663	2012	1
1/23/2012	1	2938.462	2012	1
1/23/2012	2	2893.953	2012	1
1/23/2012	3	2942.655	2012	1
1/23/2012	4	2980.963	2012	1
1/23/2012	5	3203.862	2012	1
1/23/2012	6	3609.562	2012	1
1/23/2012	7	3929.963	2012	1
1/23/2012	8	3974.862	2012	1
1/23/2012	9	3966.548	2012	1
1/23/2012	10	3994.16	2012	1
1/23/2012	11	4029.163	2012	1
1/23/2012	12	4008.262	2012	1
1/23/2012	13	3994.262	2012	1
1/23/2012	14	3937.162	2012	1
1/23/2012	15	3858.658	2012	1
1/23/2012	16	3821.95	2012	1
1/23/2012	17	3869.662	2012	1
1/23/2012	18	4200.544	2012	1
1/23/2012	19	4189.062	2012	1
1/23/2012	20	4135.362	2012	1
1/23/2012	21	4042.962	2012	1
1/23/2012	22	3777.554	2012	1
1/23/2012	23	3594.352	2012	1
1/24/2012	0	3484.762	2012	1
1/24/2012	1	3461.962	2012	1
1/24/2012	2	3462.561	2012	1
1/24/2012	3	3374.262	2012	1
1/24/2012	4	3532.66	2012	1
1/24/2012	5	3745.246	2012	1
1/24/2012	6	4190.56	2012	1
1/24/2012	7	4560.361	2012	1
1/24/2012	8	4551.361	2012	1
1/24/2012	9	4442.862	2012	1
1/24/2012	10	4310.558	2012	1
1/24/2012	11	4188.448	2012	1
1/24/2012	12	4128.062	2012	1
1/24/2012	13	4042.962	2012	1

Day	Hr	Total	Year	Month
1/24/2012	14	3949.562	2012	1
1/24/2012	15	3893.362	2012	1
1/24/2012	16	3868.663	2012	1
1/24/2012	17	4009.954	2012	1
1/24/2012	18	4332.152	2012	1
1/24/2012	19	4399.062	2012	1
1/24/2012	20	4401.661	2012	1
1/24/2012	21	4401.162	2012	1
1/24/2012	22	4163.051	2012	1
1/24/2012	23	4123.355	2012	1
1/25/2012	0	3952.861	2012	1
1/25/2012	1	3920.762	2012	1
1/25/2012	2	3818.261	2012	1
1/25/2012	3	3884.551	2012	1
1/25/2012	4	3974.056	2012	1
1/25/2012	5	4144.361	2012	1
1/25/2012	6	4549.762	2012	1
1/25/2012	7	4860.762	2012	1
1/25/2012	8	4853.156	2012	1
1/25/2012	9	4813.751	2012	1
1/25/2012	10	4716.362	2012	1
1/25/2012	11	4575.962	2012	1
1/25/2012	12	4570.862	2012	1
1/25/2012	13	4485.862	2012	1
1/25/2012	14	4413.749	2012	1
1/25/2012	15	4358.059	2012	1
1/25/2012	16	4411.562	2012	1
1/25/2012	17	4483.462	2012	1
1/25/2012	18	4659.162	2012	1
1/25/2012	19	4597.158	2012	1
1/25/2012	20	4530.248	2012	1
1/25/2012	21	4382.262	2012	1
1/25/2012	22	4125.961	2012	1
1/25/2012	23	3860.662	2012	1
1/26/2012	0	3724.362	2012	1
1/26/2012	1	3599.556	2012	1
1/26/2012	2	3523.05	2012	1
1/26/2012	3	3447.362	2012	1
1/26/2012	4	3432.162	2012	1
1/26/2012	5	3560.262	2012	1
1/26/2012	6	3956.862	2012	1
1/26/2012	7	4205.857	2012	1
1/26/2012	8	4194.15	2012	1
1/26/2012	9	4160.462	2012	1
1/26/2012	10	4161.363	2012	1
1/26/2012	11	4110.462	2012	1
1/26/2012	12	4115.562	2012	1
1/26/2012	13	4024.563	2012	1
1/26/2012	14	3935.153	2012	1
1/26/2012	15	3934.755	2012	1
1/26/2012	16	3932.163	2012	1
1/26/2012	17	4059.362	2012	1
1/26/2012	18	4191.962	2012	1
1/26/2012	19	4148.362	2012	1
1/26/2012	20	4122.962	2012	1
1/26/2012	21	3955.35	2012	1
1/26/2012	22	3740.856	2012	1
1/26/2012	23	3527.962	2012	1
1/27/2012	0	3362.061	2012	1
1/27/2012	1	3352.662	2012	1
1/27/2012	2	3291.761	2012	1
1/27/2012	3	3322.347	2012	1
1/27/2012	4	3343.659	2012	1
1/27/2012	5	3560.361	2012	1

Day	Hr	Total	Year	Month
1/27/2012	6	3992.762	2012	1
1/27/2012	7	4359.359	2012	1
1/27/2012	8	4377.656	2012	1
1/27/2012	9	4441.051	2012	1
1/27/2012	10	4486.661	2012	1
1/27/2012	11	4469.162	2012	1
1/27/2012	12	4483.062	2012	1
1/27/2012	13	4439.462	2012	1
1/27/2012	14	4411.747	2012	1
1/27/2012	15	4354.461	2012	1
1/27/2012	16	4350.596	2012	1
1/27/2012	17	4442.751	2012	1
1/27/2012	18	4500.861	2012	1
1/27/2012	19	4437.456	2012	1
1/27/2012	20	4388.05	2012	1
1/27/2012	21	4299.962	2012	1
1/27/2012	22	4108.362	2012	1
1/27/2012	23	3963.962	2012	1
1/28/2012	0	3813.362	2012	1
1/28/2012	1	3687.051	2012	1
1/28/2012	2	3668.855	2012	1
1/28/2012	3	3610.861	2012	1
1/28/2012	4	3630.562	2012	1
1/28/2012	5	3678.361	2012	1
1/28/2012	6	3741.857	2012	1
1/28/2012	7	3924.849	2012	1
1/28/2012	8	4022.489	2012	1
1/28/2012	9	4123.062	2012	1
1/28/2012	10	4110.662	2012	1
1/28/2012	11	4018.859	2012	1
1/28/2012	12	3911.648	2012	1
1/28/2012	13	3759.461	2012	1
1/28/2012	14	3631.562	2012	1
1/28/2012	15	3607.763	2012	1
1/28/2012	16	3545.062	2012	1
1/28/2012	17	3630.055	2012	1
1/28/2012	18	4024.151	2012	1
1/28/2012	19	4127.962	2012	1
1/28/2012	20	4098.661	2012	1
1/28/2012	21	4064.661	2012	1
1/28/2012	22	3976.961	2012	1
1/28/2012	23	3877.444	2012	1
1/29/2012	0	3795.861	2012	1
1/29/2012	1	3753.561	2012	1
1/29/2012	2	3725.361	2012	1
1/29/2012	3	3677.458	2012	1
1/29/2012	4	3706.447	2012	1
1/29/2012	5	3822.661	2012	1
1/29/2012	6	3925.661	2012	1
1/29/2012	7	4014.961	2012	1
1/29/2012	8	4122.055	2012	1
1/29/2012	9	4052.051	2012	1
1/29/2012	10	3918.508	2012	1
1/29/2012	11	3777.762	2012	1
1/29/2012	12	3698.862	2012	1
1/29/2012	13	3559.461	2012	1
1/29/2012	14	3501.849	2012	1
1/29/2012	15	3431.859	2012	1
1/29/2012	16	3506.562	2012	1
1/29/2012	17	3640.062	2012	1
1/29/2012	18	3998.762	2012	1
1/29/2012	19	4045.861	2012	1
1/29/2012	20	4078.049	2012	1
1/29/2012	21	4028.857	2012	1

Day	Hr	Total	Year	Month
1/29/2012	22	3893.161	2012	1
1/29/2012	23	3784.862	2012	1
1/30/2012	0	3683.062	2012	1
1/30/2012	1	3665.461	2012	1
1/30/2012	2	3701.945	2012	1
1/30/2012	3	3745.362	2012	1
1/30/2012	4	3823.561	2012	1
1/30/2012	5	4153.762	2012	1
1/30/2012	6	4579.161	2012	1
1/30/2012	7	4880.451	2012	1
1/30/2012	8	4831.156	2012	1
1/30/2012	9	4712.262	2012	1
1/30/2012	10	4500.362	2012	1
1/30/2012	11	4313.562	2012	1
1/30/2012	12	4153.662	2012	1
1/30/2012	13	4031.054	2012	1
1/30/2012	14	3928.254	2012	1
1/30/2012	15	3765.463	2012	1
1/30/2012	16	3703.062	2012	1
1/30/2012	17	3778.762	2012	1
1/30/2012	18	4035.962	2012	1
1/30/2012	19	4095.262	2012	1
1/30/2012	20	4115.261	2012	1
1/30/2012	21	3976.446	2012	1
1/30/2012	22	3768.261	2012	1
1/30/2012	23	3566.962	2012	1
1/31/2012	0	3432.862	2012	1
1/31/2012	1	3318.261	2012	1
1/31/2012	2	3265.562	2012	1
1/31/2012	3	3222.46	2012	1
1/31/2012	4	3279.946	2012	1
1/31/2012	5	3469.661	2012	1
1/31/2012	6	3920.162	2012	1
1/31/2012	7	4200.612	2012	1
1/31/2012	8	4159.462	2012	1
1/31/2012	9	4127.063	2012	1
1/31/2012	10	4042.959	2012	1
1/31/2012	11	3959.948	2012	1
1/31/2012	12	3911.462	2012	1
1/31/2012	13	3846.463	2012	1
1/31/2012	14	3772.862	2012	1
1/31/2012	15	3691.462	2012	1
1/31/2012	16	3667.663	2012	1
1/31/2012	17	3827.962	2012	1
1/31/2012	18	4035.762	2012	1
1/31/2012	19	4021.049	2012	1
1/31/2012	20	3969.157	2012	1
1/31/2012	21	3851.962	2012	1
1/31/2012	22	3659.162	2012	1
1/31/2012	23	3472.461	2012	1
2/1/2012	0	3301.062	2012	2
2/1/2012	1	3164.562	2012	2
2/1/2012	2	3080.062	2012	2
2/1/2012	3	3028.554	2012	2
2/1/2012	4	3066.452	2012	2
2/1/2012	5	3250.261	2012	2
2/1/2012	6	3662.363	2012	2
2/1/2012	7	3959.863	2012	2
2/1/2012	8	3957.164	2012	2
2/1/2012	9	3946.763	2012	2
2/1/2012	10	3953.663	2012	2
2/1/2012	11	3923.663	2012	2
2/1/2012	12	3917.457	2012	2
2/1/2012	13	3869.352	2012	2

Case No. 2018-00295
Attachment 5 to Response to Metro-1 Question No. 37(b)
Page 13 of 823
Bellar

Day	Hr	Total	Year	Month
2/1/2012	14	3865.063	2012	2
2/1/2012	15	3722.263	2012	2
2/1/2012	16	3670.463	2012	2
2/1/2012	17	3796.863	2012	2
2/1/2012	18	3953.863	2012	2
2/1/2012	19	3967.363	2012	2
2/1/2012	20	3926.863	2012	2
2/1/2012	21	3779.962	2012	2
2/1/2012	22	3562.561	2012	2
2/1/2012	23	3317.357	2012	2
2/2/2012	0	3179.249	2012	2
2/2/2012	1	3043.462	2012	2
2/2/2012	2	3014.962	2012	2
2/2/2012	3	3015.262	2012	2
2/2/2012	4	3009.162	2012	2
2/2/2012	5	3261.262	2012	2
2/2/2012	6	3731.063	2012	2
2/2/2012	7	4060.253	2012	2
2/2/2012	8	4065.454	2012	2
2/2/2012	9	4035.563	2012	2
2/2/2012	10	3977.063	2012	2
2/2/2012	11	3871.962	2012	2
2/2/2012	12	3859.164	2012	2
2/2/2012	13	3788.862	2012	2
2/2/2012	14	3776.964	2012	2
2/2/2012	15	3640.962	2012	2
2/2/2012	16	3630.951	2012	2
2/2/2012	17	3672.856	2012	2
2/2/2012	18	3934.963	2012	2
2/2/2012	19	4011.262	2012	2
2/2/2012	20	4043.963	2012	2
2/2/2012	21	3966.062	2012	2
2/2/2012	22	3815.162	2012	2
2/2/2012	23	3623.361	2012	2
2/3/2012	0	3465.249	2012	2
2/3/2012	1	3393.257	2012	2
2/3/2012	2	3416.762	2012	2
2/3/2012	3	3448.961	2012	2
2/3/2012	4	3499.662	2012	2
2/3/2012	5	3725.362	2012	2
2/3/2012	6	4145.857	2012	2
2/3/2012	7	4467.05	2012	2
2/3/2012	8	4437.863	2012	2
2/3/2012	9	4339.062	2012	2
2/3/2012	10	4218.807	2012	2
2/3/2012	11	4065.363	2012	2
2/3/2012	12	3982.924	2012	2
2/3/2012	13	3860.852	2012	2
2/3/2012	14	3777.158	2012	2
2/3/2012	15	3631.862	2012	2
2/3/2012	16	3632.863	2012	2
2/3/2012	17	3688.263	2012	2
2/3/2012	18	3885.263	2012	2
2/3/2012	19	3861.862	2012	2
2/3/2012	20	3865.862	2012	2
2/3/2012	21	3783.554	2012	2
2/3/2012	22	3630.953	2012	2
2/3/2012	23	3445.562	2012	2
2/4/2012	0	3265.362	2012	2
2/4/2012	1	3144.262	2012	2
2/4/2012	2	3026.862	2012	2
2/4/2012	3	2982.162	2012	2
2/4/2012	4	2982.862	2012	2
2/4/2012	5	3073.553	2012	2

Day	Hr	Total	Year	Month
2/4/2012	6	3241.552	2012	2
2/4/2012	7	3365.962	2012	2
2/4/2012	8	3514.763	2012	2
2/4/2012	9	3685.362	2012	2
2/4/2012	10	3794.755	2012	2
2/4/2012	11	3763.762	2012	2
2/4/2012	12	3784.85	2012	2
2/4/2012	13	3690.257	2012	2
2/4/2012	14	3661.263	2012	2
2/4/2012	15	3609.162	2012	2
2/4/2012	16	3582.962	2012	2
2/4/2012	17	3657.762	2012	2
2/4/2012	18	3775.558	2012	2
2/4/2012	19	3812.748	2012	2
2/4/2012	20	3725.162	2012	2
2/4/2012	21	3588.762	2012	2
2/4/2012	22	3437.662	2012	2
2/4/2012	23	3257.761	2012	2
2/5/2012	0	3148.454	2012	2
2/5/2012	1	3058.551	2012	2
2/5/2012	2	3000.162	2012	2
2/5/2012	3	2945.961	2012	2
2/5/2012	4	2948.362	2012	2
2/5/2012	5	2963.861	2012	2
2/5/2012	6	3122.65	2012	2
2/5/2012	7	3275.556	2012	2
2/5/2012	8	3388.962	2012	2
2/5/2012	9	3543.862	2012	2
2/5/2012	10	3558.462	2012	2
2/5/2012	11	3586.359	2012	2
2/5/2012	12	3593.948	2012	2
2/5/2012	13	3618.263	2012	2
2/5/2012	14	3556.262	2012	2
2/5/2012	15	3487.363	2012	2
2/5/2012	16	3501.362	2012	2
2/5/2012	17	3550.954	2012	2
2/5/2012	18	3736.954	2012	2
2/5/2012	19	3796.862	2012	2
2/5/2012	20	3842.862	2012	2
2/5/2012	21	3793.862	2012	2
2/5/2012	22	3757.462	2012	2
2/5/2012	23	3633.152	2012	2
2/6/2012	0	3513.654	2012	2
2/6/2012	1	3497.661	2012	2
2/6/2012	2	3516.262	2012	2
2/6/2012	3	3555.661	2012	2
2/6/2012	4	3670.56	2012	2
2/6/2012	5	3925.946	2012	2
2/6/2012	6	4376.062	2012	2
2/6/2012	7	4725.961	2012	2
2/6/2012	8	4696.963	2012	2
2/6/2012	9	4563.462	2012	2
2/6/2012	10	4407.547	2012	2
2/6/2012	11	4246.46	2012	2
2/6/2012	12	4103.562	2012	2
2/6/2012	13	4016.363	2012	2
2/6/2012	14	3911.562	2012	2
2/6/2012	15	3844.663	2012	2
2/6/2012	16	3848.679	2012	2
2/6/2012	17	3907.647	2012	2
2/6/2012	18	4225.762	2012	2
2/6/2012	19	4359.763	2012	2
2/6/2012	20	4368.661	2012	2
2/6/2012	21	4306.262	2012	2

Day	Hr	Total	Year	Month
2/6/2012	22	4153.962	2012	2
2/6/2012	23	3966.252	2012	2
2/7/2012	0	3868.954	2012	2
2/7/2012	1	3787.661	2012	2
2/7/2012	2	3790.362	2012	2
2/7/2012	3	3798.661	2012	2
2/7/2012	4	3847.262	2012	2
2/7/2012	5	4124.946	2012	2
2/7/2012	6	4566.56	2012	2
2/7/2012	7	4852.562	2012	2
2/7/2012	8	4790.061	2012	2
2/7/2012	9	4620.427	2012	2
2/7/2012	10	4417.957	2012	2
2/7/2012	11	4271.552	2012	2
2/7/2012	12	4126.263	2012	2
2/7/2012	13	4067.263	2012	2
2/7/2012	14	3923.362	2012	2
2/7/2012	15	3835.164	2012	2
2/7/2012	16	3826.163	2012	2
2/7/2012	17	3897.163	2012	2
2/7/2012	18	4206.846	2012	2
2/7/2012	19	4299.56	2012	2
2/7/2012	20	4336.463	2012	2
2/7/2012	21	4264.862	2012	2
2/7/2012	22	4065.961	2012	2
2/7/2012	23	3857.746	2012	2
2/8/2012	0	3783.96	2012	2
2/8/2012	1	3653.962	2012	2
2/8/2012	2	3618.062	2012	2
2/8/2012	3	3572.859	2012	2
2/8/2012	4	3622.046	2012	2
2/8/2012	5	3896.662	2012	2
2/8/2012	6	4286.562	2012	2
2/8/2012	7	4600.261	2012	2
2/8/2012	8	4637.662	2012	2
2/8/2012	9	4617.246	2012	2
2/8/2012	10	4638.462	2012	2
2/8/2012	11	4624.062	2012	2
2/8/2012	12	4609.962	2012	2
2/8/2012	13	4587.163	2012	2
2/8/2012	14	4556.154	2012	2
2/8/2012	15	4532.753	2012	2
2/8/2012	16	4563.762	2012	2
2/8/2012	17	4632.962	2012	2
2/8/2012	18	4775.462	2012	2
2/8/2012	19	4761.862	2012	2
2/8/2012	20	4655.048	2012	2
2/8/2012	21	4507.958	2012	2
2/8/2012	22	4318.561	2012	2
2/8/2012	23	4124.962	2012	2
2/9/2012	0	3960.461	2012	2
2/9/2012	1	3854.057	2012	2
2/9/2012	2	3756.549	2012	2
2/9/2012	3	3771.262	2012	2
2/9/2012	4	3767.561	2012	2
2/9/2012	5	4003.662	2012	2
2/9/2012	6	4429.962	2012	2
2/9/2012	7	4686.945	2012	2
2/9/2012	8	4675.161	2012	2
2/9/2012	9	4722.162	2012	2
2/9/2012	10	4677.662	2012	2
2/9/2012	11	4646.763	2012	2
2/9/2012	12	4620.956	2012	2
2/9/2012	13	4552.151	2012	2

Day	Hr	Total	Year	Month
2/9/2012	14	4489.963	2012	2
2/9/2012	15	4426.262	2012	2
2/9/2012	16	4420.062	2012	2
2/9/2012	17	4487.262	2012	2
2/9/2012	18	4695.655	2012	2
2/9/2012	19	4731.452	2012	2
2/9/2012	20	4685.862	2012	2
2/9/2012	21	4564.262	2012	2
2/9/2012	22	4358.162	2012	2
2/9/2012	23	4161.062	2012	2
2/10/2012	0	4046.251	2012	2
2/10/2012	1	3987.756	2012	2
2/10/2012	2	3950.362	2012	2
2/10/2012	3	3900.362	2012	2
2/10/2012	4	3953.362	2012	2
2/10/2012	5	4185.662	2012	2
2/10/2012	6	4567.847	2012	2
2/10/2012	7	4844.06	2012	2
2/10/2012	8	4828.463	2012	2
2/10/2012	9	4810.371	2012	2
2/10/2012	10	4775.163	2012	2
2/10/2012	11	4676.959	2012	2
2/10/2012	12	4643.049	2012	2
2/10/2012	13	4515.463	2012	2
2/10/2012	14	4487.662	2012	2
2/10/2012	15	4502.063	2012	2
2/10/2012	16	4490.862	2012	2
2/10/2012	17	4577.356	2012	2
2/10/2012	18	4692.752	2012	2
2/10/2012	19	4666.062	2012	2
2/10/2012	20	4613.162	2012	2
2/10/2012	21	4481.262	2012	2
2/10/2012	22	4271.246	2012	2
2/10/2012	23	4176.051	2012	2
2/11/2012	0	4050.956	2012	2
2/11/2012	1	3938.162	2012	2
2/11/2012	2	3923.462	2012	2
2/11/2012	3	3917.962	2012	2
2/11/2012	4	3972.652	2012	2
2/11/2012	5	4118.753	2012	2
2/11/2012	6	4329.662	2012	2
2/11/2012	7	4526.862	2012	2
2/11/2012	8	4665.862	2012	2
2/11/2012	9	4746.449	2012	2
2/11/2012	10	4826.058	2012	2
2/11/2012	11	4808.362	2012	2
2/11/2012	12	4702.862	2012	2
2/11/2012	13	4715.362	2012	2
2/11/2012	14	4638.349	2012	2
2/11/2012	15	4590.859	2012	2
2/11/2012	16	4630.362	2012	2
2/11/2012	17	4740.663	2012	2
2/11/2012	18	5008.361	2012	2
2/11/2012	19	5061.846	2012	2
2/11/2012	20	5014.761	2012	2
2/11/2012	21	4966.661	2012	2
2/11/2012	22	4791.161	2012	2
2/11/2012	23	4638.421	2012	2
2/12/2012	0	4436.253	2012	2
2/12/2012	1	4434.061	2012	2
2/12/2012	2	4456.561	2012	2
2/12/2012	3	4468.959	2012	2
2/12/2012	4	4503.545	2012	2
2/12/2012	5	4562.761	2012	2

Day	Hr	Total	Year	Month
2/12/2012	6	4622.061	2012	2
2/12/2012	7	4800.662	2012	2
2/12/2012	8	4777.348	2012	2
2/12/2012	9	4738.058	2012	2
2/12/2012	10	4594.662	2012	2
2/12/2012	11	4421.562	2012	2
2/12/2012	12	4216.861	2012	2
2/12/2012	13	4117.646	2012	2
2/12/2012	14	3957.263	2012	2
2/12/2012	15	3857.063	2012	2
2/12/2012	16	3848.262	2012	2
2/12/2012	17	3947.072	2012	2
2/12/2012	18	4302.449	2012	2
2/12/2012	19	4471.258	2012	2
2/12/2012	20	4544.562	2012	2
2/12/2012	21	4474.461	2012	2
2/12/2012	22	4356.862	2012	2
2/12/2012	23	4250.85	2012	2
2/13/2012	0	4159.256	2012	2
2/13/2012	1	4169.561	2012	2
2/13/2012	2	4187.362	2012	2
2/13/2012	3	4273.361	2012	2
2/13/2012	4	4431.748	2012	2
2/13/2012	5	4682.057	2012	2
2/13/2012	6	5078.262	2012	2
2/13/2012	7	5395.361	2012	2
2/13/2012	8	5331.061	2012	2
2/13/2012	9	5136.546	2012	2
2/13/2012	10	4980.362	2012	2
2/13/2012	11	4837.262	2012	2
2/13/2012	12	4740.363	2012	2
2/13/2012	13	4630.062	2012	2
2/13/2012	14	4583.652	2012	2
2/13/2012	15	4538.456	2012	2
2/13/2012	16	4518.962	2012	2
2/13/2012	17	4607.462	2012	2
2/13/2012	18	4719.562	2012	2
2/13/2012	19	4777.66	2012	2
2/13/2012	20	4763.347	2012	2
2/13/2012	21	4618.161	2012	2
2/13/2012	22	4378.562	2012	2
2/13/2012	23	4165.362	2012	2
2/14/2012	0	4027.062	2012	2
2/14/2012	1	3885.652	2012	2
2/14/2012	2	3844.754	2012	2
2/14/2012	3	3796.261	2012	2
2/14/2012	4	3828.962	2012	2
2/14/2012	5	4021.262	2012	2
2/14/2012	6	4425.56	2012	2
2/14/2012	7	4725.546	2012	2
2/14/2012	8	4717.062	2012	2
2/14/2012	9	4761.462	2012	2
2/14/2012	10	4769.562	2012	2
2/14/2012	11	4704.762	2012	2
2/14/2012	12	4713.154	2012	2
2/14/2012	13	4657.554	2012	2
2/14/2012	14	4580.262	2012	2
2/14/2012	15	4506.263	2012	2
2/14/2012	16	4472.162	2012	2
2/14/2012	17	4511.562	2012	2
2/14/2012	18	4700.754	2012	2
2/14/2012	19	4673.053	2012	2
2/14/2012	20	4640.662	2012	2
2/14/2012	21	4506.462	2012	2

Day	Hr	Total	Year	Month
2/14/2012	22	4260.762	2012	2
2/14/2012	23	4083.161	2012	2
2/15/2012	0	3958.055	2012	2
2/15/2012	1	3872.352	2012	2
2/15/2012	2	3851.062	2012	2
2/15/2012	3	3796.662	2012	2
2/15/2012	4	3882.162	2012	2
2/15/2012	5	4114.861	2012	2
2/15/2012	6	4535.754	2012	2
2/15/2012	7	4797.253	2012	2
2/15/2012	8	4736.662	2012	2
2/15/2012	9	4616.362	2012	2
2/15/2012	10	4455.763	2012	2
2/15/2012	11	4322.362	2012	2
2/15/2012	12	4195.957	2012	2
2/15/2012	13	4144.552	2012	2
2/15/2012	14	4066.663	2012	2
2/15/2012	15	3994.562	2012	2
2/15/2012	16	4002.763	2012	2
2/15/2012	17	4061.563	2012	2
2/15/2012	18	4237.962	2012	2
2/15/2012	19	4263.955	2012	2
2/15/2012	20	4243.952	2012	2
2/15/2012	21	4107.262	2012	2
2/15/2012	22	3894.362	2012	2
2/15/2012	23	3699.962	2012	2
2/16/2012	0	3498.462	2012	2
2/16/2012	1	3392.362	2012	2
2/16/2012	2	3332.049	2012	2
2/16/2012	3	3292.857	2012	2
2/16/2012	4	3317.962	2012	2
2/16/2012	5	3465.962	2012	2
2/16/2012	6	3873.562	2012	2
2/16/2012	7	4139.162	2012	2
2/16/2012	8	4122.263	2012	2
2/16/2012	9	4165.147	2012	2
2/16/2012	10	4179.261	2012	2
2/16/2012	11	4157.063	2012	2
2/16/2012	12	4197.762	2012	2
2/16/2012	13	4153.363	2012	2
2/16/2012	14	4058.163	2012	2
2/16/2012	15	4040.062	2012	2
2/16/2012	16	3989.249	2012	2
2/16/2012	17	4073.159	2012	2
2/16/2012	18	4228.562	2012	2
2/16/2012	19	4269.663	2012	2
2/16/2012	20	4231.861	2012	2
2/16/2012	21	4130.962	2012	2
2/16/2012	22	3946.362	2012	2
2/16/2012	23	3669.348	2012	2
2/17/2012	0	3543.667	2012	2
2/17/2012	1	3474.962	2012	2
2/17/2012	2	3485.462	2012	2
2/17/2012	3	3497.162	2012	2
2/17/2012	4	3583.161	2012	2
2/17/2012	5	3813.346	2012	2
2/17/2012	6	4222.66	2012	2
2/17/2012	7	4533.262	2012	2
2/17/2012	8	4494.262	2012	2
2/17/2012	9	4357.463	2012	2
2/17/2012	10	4205.857	2012	2
2/17/2012	11	4079.652	2012	2
2/17/2012	12	4018.363	2012	2
2/17/2012	13	3927.263	2012	2

Day	Hr	Total	Year	Month
2/17/2012	14	3835.77	2012	2
2/17/2012	15	3739.463	2012	2
2/17/2012	16	3678.763	2012	2
2/17/2012	17	3688.364	2012	2
2/17/2012	18	3879.954	2012	2
2/17/2012	19	3998.254	2012	2
2/17/2012	20	3976.162	2012	2
2/17/2012	21	3913.662	2012	2
2/17/2012	22	3799.662	2012	2
2/17/2012	23	3685.662	2012	2
2/18/2012	0	3513.161	2012	2
2/18/2012	1	3444.146	2012	2
2/18/2012	2	3451.161	2012	2
2/18/2012	3	3349.462	2012	2
2/18/2012	4	3387.661	2012	2
2/18/2012	5	3469.362	2012	2
2/18/2012	6	3618.76	2012	2
2/18/2012	7	3789.946	2012	2
2/18/2012	8	3893.662	2012	2
2/18/2012	9	3896.463	2012	2
2/18/2012	10	3786.562	2012	2
2/18/2012	11	3698.263	2012	2
2/18/2012	12	3589.962	2012	2
2/18/2012	13	3480.853	2012	2
2/18/2012	14	3417.456	2012	2
2/18/2012	15	3393.263	2012	2
2/18/2012	16	3420.362	2012	2
2/18/2012	17	3498.663	2012	2
2/18/2012	18	3695.762	2012	2
2/18/2012	19	3758.798	2012	2
2/18/2012	20	3758.748	2012	2
2/18/2012	21	3672.762	2012	2
2/18/2012	22	3545.361	2012	2
2/18/2012	23	3399.062	2012	2
2/19/2012	0	3319.158	2012	2
2/19/2012	1	3224.148	2012	2
2/19/2012	2	3216.562	2012	2
2/19/2012	3	3233.461	2012	2
2/19/2012	4	3233.862	2012	2
2/19/2012	5	3296.852	2012	2
2/19/2012	6	3456.753	2012	2
2/19/2012	7	3566.662	2012	2
2/19/2012	8	3681.862	2012	2
2/19/2012	9	3851.757	2012	2
2/19/2012	10	3904.249	2012	2
2/19/2012	11	3921.762	2012	2
2/19/2012	12	3975.763	2012	2
2/19/2012	13	3951.562	2012	2
2/19/2012	14	3927.249	2012	2
2/19/2012	15	3893.72	2012	2
2/19/2012	16	3923.463	2012	2
2/19/2012	17	4012.162	2012	2
2/19/2012	18	4117.862	2012	2
2/19/2012	19	4239.846	2012	2
2/19/2012	20	4204.461	2012	2
2/19/2012	21	4126.761	2012	2
2/19/2012	22	3992.462	2012	2
2/19/2012	23	3859.556	2012	2
2/20/2012	0	3779.15	2012	2
2/20/2012	1	3774.562	2012	2
2/20/2012	2	3815.761	2012	2
2/20/2012	3	3881.056	2012	2
2/20/2012	4	3949.55	2012	2
2/20/2012	5	4238.462	2012	2

Day	Hr	Total	Year	Month
2/20/2012	6	4662.261	2012	2
2/20/2012	7	4946.961	2012	2
2/20/2012	8	4938.146	2012	2
2/20/2012	9	4806.662	2012	2
2/20/2012	10	4661.749	2012	2
2/20/2012	11	4484.962	2012	2
2/20/2012	12	4376.563	2012	2
2/20/2012	13	4241.248	2012	2
2/20/2012	14	4083.46	2012	2
2/20/2012	15	3939.164	2012	2
2/20/2012	16	3906.962	2012	2
2/20/2012	17	3958.363	2012	2
2/20/2012	18	4239.863	2012	2
2/20/2012	19	4454.448	2012	2
2/20/2012	20	4479.36	2012	2
2/20/2012	21	4383.662	2012	2
2/20/2012	22	4210.361	2012	2
2/20/2012	23	4024.562	2012	2
2/21/2012	0	3911.462	2012	2
2/21/2012	1	3821.948	2012	2
2/21/2012	2	3730.559	2012	2
2/21/2012	3	3649.962	2012	2
2/21/2012	4	3631.262	2012	2
2/21/2012	5	3781.762	2012	2
2/21/2012	6	4166.061	2012	2
2/21/2012	7	4406.148	2012	2
2/21/2012	8	4418.46	2012	2
2/21/2012	9	4379.162	2012	2
2/21/2012	10	4325.062	2012	2
2/21/2012	11	4203.463	2012	2
2/21/2012	12	4248.962	2012	2
2/21/2012	13	4151.458	2012	2
2/21/2012	14	4146	2012	2
2/21/2012	15	4082.749	2012	2
2/21/2012	16	3973.062	2012	2
2/21/2012	17	3928.963	2012	2
2/21/2012	18	4139.662	2012	2
2/21/2012	19	4239.362	2012	2
2/21/2012	20	4206.049	2012	2
2/21/2012	21	4063.755	2012	2
2/21/2012	22	3884.661	2012	2
2/21/2012	23	3718.363	2012	2
2/22/2012	0	3578.961	2012	2
2/22/2012	1	3524.862	2012	2
2/22/2012	2	3475.758	2012	2
2/22/2012	3	3482.049	2012	2
2/22/2012	4	3534.062	2012	2
2/22/2012	5	3728.962	2012	2
2/22/2012	6	4154.962	2012	2
2/22/2012	7	4399.562	2012	2
2/22/2012	8	4327.862	2012	2
2/22/2012	9	4245.552	2012	2
2/22/2012	10	4152.856	2012	2
2/22/2012	11	4037.163	2012	2
2/22/2012	12	3967.462	2012	2
2/22/2012	13	3933.963	2012	2
2/22/2012	14	3873.463	2012	2
2/22/2012	15	3782.463	2012	2
2/22/2012	16	3804.562	2012	2
2/22/2012	17	3891.449	2012	2
2/22/2012	18	4049.159	2012	2
2/22/2012	19	4096.762	2012	2
2/22/2012	20	4037.363	2012	2
2/22/2012	21	3919.162	2012	2

Day	Hr	Total	Year	Month
2/22/2012	22	3686.362	2012	2
2/22/2012	23	3479.462	2012	2
2/23/2012	0	3336.76	2012	2
2/23/2012	1	3242.647	2012	2
2/23/2012	2	3171.562	2012	2
2/23/2012	3	3185.462	2012	2
2/23/2012	4	3185.862	2012	2
2/23/2012	5	3370.962	2012	2
2/23/2012	6	3840.962	2012	2
2/23/2012	7	4099.562	2012	2
2/23/2012	8	4094.447	2012	2
2/23/2012	9	4060.36	2012	2
2/23/2012	10	4042.063	2012	2
2/23/2012	11	3902.763	2012	2
2/23/2012	12	3839.862	2012	2
2/23/2012	13	3805.963	2012	2
2/23/2012	14	3684.563	2012	2
2/23/2012	15	3604.763	2012	2
2/23/2012	16	3618.962	2012	2
2/23/2012	17	3667.447	2012	2
2/23/2012	18	3795.663	2012	2
2/23/2012	19	3866.263	2012	2
2/23/2012	20	3811.462	2012	2
2/23/2012	21	3664.663	2012	2
2/23/2012	22	3489.762	2012	2
2/23/2012	23	3266.863	2012	2
2/24/2012	0	3039.562	2012	2
2/24/2012	1	2971.663	2012	2
2/24/2012	2	2883.861	2012	2
2/24/2012	3	2851.945	2012	2
2/24/2012	4	2872.662	2012	2
2/24/2012	5	3058.463	2012	2
2/24/2012	6	3442.462	2012	2
2/24/2012	7	3754.962	2012	2
2/24/2012	8	3834.163	2012	2
2/24/2012	9	3925.862	2012	2
2/24/2012	10	4001.251	2012	2
2/24/2012	11	4051.055	2012	2
2/24/2012	12	4137.963	2012	2
2/24/2012	13	4142.562	2012	2
2/24/2012	14	4172.762	2012	2
2/24/2012	15	4114.062	2012	2
2/24/2012	16	4144.051	2012	2
2/24/2012	17	4184.956	2012	2
2/24/2012	18	4310.962	2012	2
2/24/2012	19	4361.262	2012	2
2/24/2012	20	4314.962	2012	2
2/24/2012	21	4238.18	2012	2
2/24/2012	22	4081.947	2012	2
2/24/2012	23	3923.059	2012	2
2/25/2012	0	3799.262	2012	2
2/25/2012	1	3679.662	2012	2
2/25/2012	2	3636.661	2012	2
2/25/2012	3	3587.352	2012	2
2/25/2012	4	3632.054	2012	2
2/25/2012	5	3745.262	2012	2
2/25/2012	6	3805.662	2012	2
2/25/2012	7	3958.362	2012	2
2/25/2012	8	4059.559	2012	2
2/25/2012	9	4138.448	2012	2
2/25/2012	10	4078.862	2012	2
2/25/2012	11	4140.562	2012	2
2/25/2012	12	4012.562	2012	2
2/25/2012	13	3954.063	2012	2

Day	Hr	Total	Year	Month
2/25/2012	14	3860.85	2012	2
2/25/2012	15	3715.557	2012	2
2/25/2012	16	3626.363	2012	2
2/25/2012	17	3701.362	2012	2
2/25/2012	18	3876.063	2012	2
2/25/2012	19	4154.962	2012	2
2/25/2012	20	4179.051	2012	2
2/25/2012	21	4121.454	2012	2
2/25/2012	22	4056.662	2012	2
2/25/2012	23	3890.362	2012	2
2/26/2012	0	3840.533	2012	2
2/26/2012	1	3795.462	2012	2
2/26/2012	2	3776.545	2012	2
2/26/2012	3	3788.261	2012	2
2/26/2012	4	3875.361	2012	2
2/26/2012	5	3962.661	2012	2
2/26/2012	6	4047.762	2012	2
2/26/2012	7	4133.849	2012	2
2/26/2012	8	4131.257	2012	2
2/26/2012	9	3969.062	2012	2
2/26/2012	10	3743.763	2012	2
2/26/2012	11	3638.562	2012	2
2/26/2012	12	3455.862	2012	2
2/26/2012	13	3363.954	2012	2
2/26/2012	14	3248.456	2012	2
2/26/2012	15	3182.963	2012	2
2/26/2012	16	3181.047	2012	2
2/26/2012	17	3223.764	2012	2
2/26/2012	18	3414.762	2012	2
2/26/2012	19	3677.862	2012	2
2/26/2012	20	3705.663	2012	2
2/26/2012	21	3640.045	2012	2
2/26/2012	22	3510.161	2012	2
2/26/2012	23	3392.562	2012	2
2/27/2012	0	3289.262	2012	2
2/27/2012	1	3170.362	2012	2
2/27/2012	2	3242.162	2012	2
2/27/2012	3	3295.862	2012	2
2/27/2012	4	3313.745	2012	2
2/27/2012	5	3557.562	2012	2
2/27/2012	6	3976.161	2012	2
2/27/2012	7	4206.463	2012	2
2/27/2012	8	4186.662	2012	2
2/27/2012	9	4117.363	2012	2
2/27/2012	10	3979.762	2012	2
2/27/2012	11	3895.958	2012	2
2/27/2012	12	3841.251	2012	2
2/27/2012	13	3769.263	2012	2
2/27/2012	14	3700.363	2012	2
2/27/2012	15	3624.967	2012	2
2/27/2012	16	3579.462	2012	2
2/27/2012	17	3606.863	2012	2
2/27/2012	18	3741.763	2012	2
2/27/2012	19	3944.263	2012	2
2/27/2012	20	3923.561	2012	2
2/27/2012	21	3807.454	2012	2
2/27/2012	22	3626.052	2012	2
2/27/2012	23	3443.062	2012	2
2/28/2012	0	3343.761	2012	2
2/28/2012	1	3340.563	2012	2
2/28/2012	2	3288.561	2012	2
2/28/2012	3	3342.758	2012	2
2/28/2012	4	3421.648	2012	2
2/28/2012	5	3654.462	2012	2

Day	Hr	Total	Year	Month
2/28/2012	6	4178.061	2012	2
2/28/2012	7	4403.263	2012	2
2/28/2012	8	4343.362	2012	2
2/28/2012	9	4213.955	2012	2
2/28/2012	10	4069.649	2012	2
2/28/2012	11	3927.963	2012	2
2/28/2012	12	3852.062	2012	2
2/28/2012	13	3748.863	2012	2
2/28/2012	14	3644.063	2012	2
2/28/2012	15	3619.963	2012	2
2/28/2012	16	3570.562	2012	2
2/28/2012	17	3549.863	2012	2
2/28/2012	18	3667.663	2012	2
2/28/2012	19	3857.252	2012	2
2/28/2012	20	3816.555	2012	2
2/28/2012	21	3653.263	2012	2
2/28/2012	22	3417.362	2012	2
2/28/2012	23	3162.063	2012	2
2/29/2012	0	2992.162	2012	2
2/29/2012	1	2865.162	2012	2
2/29/2012	2	2813.662	2012	2
2/29/2012	3	2776.663	2012	2
2/29/2012	4	2810.262	2012	2
2/29/2012	5	2971.548	2012	2
2/29/2012	6	3350.459	2012	2
2/29/2012	7	3647.363	2012	2
2/29/2012	8	3699.763	2012	2
2/29/2012	9	3740.863	2012	2
2/29/2012	10	3691.263	2012	2
2/29/2012	11	3764.363	2012	2
2/29/2012	12	3745.863	2012	2
2/29/2012	13	3717.863	2012	2
2/29/2012	14	3673.862	2012	2
2/29/2012	15	3600.563	2012	2
2/29/2012	16	3549.061	2012	2
2/29/2012	17	3561.847	2012	2
2/29/2012	18	3713.162	2012	2
2/29/2012	19	3848.763	2012	2
2/29/2012	20	3829.862	2012	2
2/29/2012	21	3630.063	2012	2
2/29/2012	22	3445.262	2012	2
2/29/2012	23	3185.263	2012	2
3/1/2012	0	2996.762	2012	3
3/1/2012	1	2949.162	2012	3
3/1/2012	2	2884.462	2012	3
3/1/2012	3	2930.054	2012	3
3/1/2012	4	2983.051	2012	3
3/1/2012	5	3185.285	2012	3
3/1/2012	6	3641.362	2012	3
3/1/2012	7	3891.662	2012	3
3/1/2012	8	3886.163	2012	3
3/1/2012	9	3851.762	2012	3
3/1/2012	10	3840.763	2012	3
3/1/2012	11	3772.563	2012	3
3/1/2012	12	3750.362	2012	3
3/1/2012	13	3734.351	2012	3
3/1/2012	14	3699.257	2012	3
3/1/2012	15	3625.563	2012	3
3/1/2012	16	3561.763	2012	3
3/1/2012	17	3531.563	2012	3
3/1/2012	18	3647.062	2012	3
3/1/2012	19	3824.963	2012	3
3/1/2012	20	3852.462	2012	3
3/1/2012	21	3734.363	2012	3

Day	Hr	Total	Year	Month
3/1/2012	22	3605.762	2012	3
3/1/2012	23	3402.749	2012	3
3/2/2012	0	3272.456	2012	3
3/2/2012	1	3205.962	2012	3
3/2/2012	2	3160.262	2012	3
3/2/2012	3	3139.462	2012	3
3/2/2012	4	3181.462	2012	3
3/2/2012	5	3322.262	2012	3
3/2/2012	6	3678.763	2012	3
3/2/2012	7	3860.558	2012	3
3/2/2012	8	3891.149	2012	3
3/2/2012	9	3893.463	2012	3
3/2/2012	10	3872.263	2012	3
3/2/2012	11	3869.163	2012	3
3/2/2012	12	3885.262	2012	3
3/2/2012	13	3825.463	2012	3
3/2/2012	14	3735.763	2012	3
3/2/2012	15	3463.163	2012	3
3/2/2012	16	3270.763	2012	3
3/2/2012	17	3248.163	2012	3
3/2/2012	18	3298.763	2012	3
3/2/2012	19	3442.246	2012	3
3/2/2012	20	3491.059	2012	3
3/2/2012	21	3386.462	2012	3
3/2/2012	22	3283.061	2012	3
3/2/2012	23	3190.662	2012	3
3/3/2012	0	3053.162	2012	3
3/3/2012	1	3000.462	2012	3
3/3/2012	2	2978.657	2012	3
3/3/2012	3	2993.647	2012	3
3/3/2012	4	3035.562	2012	3
3/3/2012	5	3177.861	2012	3
3/3/2012	6	3373.962	2012	3
3/3/2012	7	3535.162	2012	3
3/3/2012	8	3704.159	2012	3
3/3/2012	9	3716.647	2012	3
3/3/2012	10	3720.163	2012	3
3/3/2012	11	3628.262	2012	3
3/3/2012	12	3540.062	2012	3
3/3/2012	13	3459.563	2012	3
3/3/2012	14	3355.162	2012	3
3/3/2012	15	3251.563	2012	3
3/3/2012	16	3262.547	2012	3
3/3/2012	17	3307.26	2012	3
3/3/2012	18	3523.362	2012	3
3/3/2012	19	3694.262	2012	3
3/3/2012	20	3724.462	2012	3
3/3/2012	21	3691.062	2012	3
3/3/2012	22	3624.46	2012	3
3/3/2012	23	3461.846	2012	3
3/4/2012	0	3392.561	2012	3
3/4/2012	1	3322.862	2012	3
3/4/2012	2	3338.061	2012	3
3/4/2012	3	3275.462	2012	3
3/4/2012	4	3361.757	2012	3
3/4/2012	5	3500.448	2012	3
3/4/2012	6	3548.662	2012	3
3/4/2012	7	3661.661	2012	3
3/4/2012	8	3784.163	2012	3
3/4/2012	9	3836.262	2012	3
3/4/2012	10	3767.352	2012	3
3/4/2012	11	3741.155	2012	3
3/4/2012	12	3740.263	2012	3
3/4/2012	13	3632.363	2012	3

Day	Hr	Total	Year	Month
3/4/2012	14	3542.562	2012	3
3/4/2012	15	3451.263	2012	3
3/4/2012	16	3450.962	2012	3
3/4/2012	17	3536.049	2012	3
3/4/2012	18	3818.303	2012	3
3/4/2012	19	3995.061	2012	3
3/4/2012	20	3997.162	2012	3
3/4/2012	21	3925.161	2012	3
3/4/2012	22	3725.662	2012	3
3/4/2012	23	3616.149	2012	3
3/5/2012	0	3521.756	2012	3
3/5/2012	1	3476.062	2012	3
3/5/2012	2	3444.461	2012	3
3/5/2012	3	3533.762	2012	3
3/5/2012	4	3629.65	2012	3
3/5/2012	5	3892.355	2012	3
3/5/2012	6	4289.162	2012	3
3/5/2012	7	4538.162	2012	3
3/5/2012	8	4661.662	2012	3
3/5/2012	9	4635.255	2012	3
3/5/2012	10	4631.717	2012	3
3/5/2012	11	4586.862	2012	3
3/5/2012	12	4589.562	2012	3
3/5/2012	13	4508.463	2012	3
3/5/2012	14	4349.462	2012	3
3/5/2012	15	4225.253	2012	3
3/5/2012	16	4205.656	2012	3
3/5/2012	17	4238.462	2012	3
3/5/2012	18	4454.763	2012	3
3/5/2012	19	4733.662	2012	3
3/5/2012	20	4743.462	2012	3
3/5/2012	21	4664.055	2012	3
3/5/2012	22	4428.751	2012	3
3/5/2012	23	4294.462	2012	3
3/6/2012	0	4158.962	2012	3
3/6/2012	1	4091.261	2012	3
3/6/2012	2	4073.062	2012	3
3/6/2012	3	4080.65	2012	3
3/6/2012	4	4075.757	2012	3
3/6/2012	5	4290.761	2012	3
3/6/2012	6	4703.362	2012	3
3/6/2012	7	4850.962	2012	3
3/6/2012	8	4735.067	2012	3
3/6/2012	9	4540.421	2012	3
3/6/2012	10	4365.063	2012	3
3/6/2012	11	4203.263	2012	3
3/6/2012	12	4119.263	2012	3
3/6/2012	13	4029.263	2012	3
3/6/2012	14	3915.563	2012	3
3/6/2012	15	3786.363	2012	3
3/6/2012	16	3719.563	2012	3
3/6/2012	17	3656.848	2012	3
3/6/2012	18	3765.862	2012	3
3/6/2012	19	4017.462	2012	3
3/6/2012	20	4000.463	2012	3
3/6/2012	21	3886.562	2012	3
3/6/2012	22	3685.463	2012	3
3/6/2012	23	3490.58	2012	3
3/7/2012	0	3343.562	2012	3
3/7/2012	1	3217.557	2012	3
3/7/2012	2	3167.45	2012	3
3/7/2012	3	3107.562	2012	3
3/7/2012	4	3168.863	2012	3
3/7/2012	5	3401.062	2012	3

Day	Hr	Total	Year	Month
3/7/2012	6	3825.463	2012	3
3/7/2012	7	4005.163	2012	3
3/7/2012	8	3982.663	2012	3
3/7/2012	9	3926.153	2012	3
3/7/2012	10	3880.655	2012	3
3/7/2012	11	3817.763	2012	3
3/7/2012	12	3813.063	2012	3
3/7/2012	13	3741.563	2012	3
3/7/2012	14	3736.363	2012	3
3/7/2012	15	3645.063	2012	3
3/7/2012	16	3609.163	2012	3
3/7/2012	17	3601.363	2012	3
3/7/2012	18	3696.563	2012	3
3/7/2012	19	3914.163	2012	3
3/7/2012	20	3826.257	2012	3
3/7/2012	21	3745.85	2012	3
3/7/2012	22	3517.963	2012	3
3/7/2012	23	3262.662	2012	3
3/8/2012	0	3104.963	2012	3
3/8/2012	1	3020.462	2012	3
3/8/2012	2	2946.563	2012	3
3/8/2012	3	2860.162	2012	3
3/8/2012	4	2897.662	2012	3
3/8/2012	5	3065.361	2012	3
3/8/2012	6	3459.762	2012	3
3/8/2012	7	3683.25	2012	3
3/8/2012	8	3756.055	2012	3
3/8/2012	9	3812.761	2012	3
3/8/2012	10	3889.562	2012	3
3/8/2012	11	3878.562	2012	3
3/8/2012	12	3941.062	2012	3
3/8/2012	13	3958.062	2012	3
3/8/2012	14	3924.262	2012	3
3/8/2012	15	3875.462	2012	3
3/8/2012	16	3864.554	2012	3
3/8/2012	17	3930.05	2012	3
3/8/2012	18	4020.462	2012	3
3/8/2012	19	4122.161	2012	3
3/8/2012	20	4110.361	2012	3
3/8/2012	21	3968.361	2012	3
3/8/2012	22	3780.561	2012	3
3/8/2012	23	3612.761	2012	3
3/9/2012	0	3418.123	2012	3
3/9/2012	1	3362.451	2012	3
3/9/2012	2	3333.061	2012	3
3/9/2012	3	3316.461	2012	3
3/9/2012	4	3356.361	2012	3
3/9/2012	5	3627.661	2012	3
3/9/2012	6	4126.862	2012	3
3/9/2012	7	4356.948	2012	3
3/9/2012	8	4325.457	2012	3
3/9/2012	9	4222.961	2012	3
3/9/2012	10	4124.062	2012	3
3/9/2012	11	4017.562	2012	3
3/9/2012	12	3987.762	2012	3
3/9/2012	13	3878.162	2012	3
3/9/2012	14	3733.362	2012	3
3/9/2012	15	3671.449	2012	3
3/9/2012	16	3563.458	2012	3
3/9/2012	17	3586.562	2012	3
3/9/2012	18	3751.963	2012	3
3/9/2012	19	3963.761	2012	3
3/9/2012	20	4010.061	2012	3
3/9/2012	21	3943.361	2012	3

Case No. 2018-00295
Attachment 5 to Response to Metro-1 Question No. 37(b)
Page 27 of 823
Bellar

Day	Hr	Total	Year	Month
3/9/2012	22	3850.845	2012	3
3/9/2012	23	3689.961	2012	3
3/10/2012	0	3603.261	2012	3
3/10/2012	1	3514.861	2012	3
3/10/2012	2	3474.461	2012	3
3/10/2012	3	3497.155	2012	3
3/10/2012	4	3474.85	2012	3
3/10/2012	5	3604.961	2012	3
3/10/2012	6	3754.461	2012	3
3/10/2012	7	3838.462	2012	3
3/10/2012	8	3850.361	2012	3
3/10/2012	9	3818.051	2012	3
3/10/2012	10	3712.456	2012	3
3/10/2012	11	3614.262	2012	3
3/10/2012	12	3457.562	2012	3
3/10/2012	13	3293.662	2012	3
3/10/2012	14	3219.362	2012	3
3/10/2012	15	3102.262	2012	3
3/10/2012	16	3100.662	2012	3
3/10/2012	17	3081.355	2012	3
3/10/2012	18	3224.052	2012	3
3/10/2012	19	3460.962	2012	3
3/10/2012	20	3448.061	2012	3
3/10/2012	21	3462.662	2012	3
3/10/2012	22	3356.219	2012	3
3/10/2012	23	3241.861	2012	3
3/11/2012	0	3106.361	2012	3
3/11/2012	1	3008.953	2012	3
3/11/2012	2	3019.052	2012	3
3/11/2012	3	3115.061	2012	3
3/11/2012	4	3142.261	2012	3
3/11/2012	5	3303.362	2012	3
3/11/2012	6	3445.361	2012	3
3/11/2012	7	3466.662	2012	3
3/11/2012	8	3460.047	2012	3
3/11/2012	9	3345.259	2012	3
3/11/2012	10	3204.362	2012	3
3/11/2012	11	3162.562	2012	3
3/11/2012	12	3090.263	2012	3
3/11/2012	13	3053.762	2012	3
3/11/2012	14	2973.262	2012	3
3/11/2012	15	2998.463	2012	3
3/11/2012	16	2975.962	2012	3
3/11/2012	17	3002.063	2012	3
3/11/2012	18	3183.562	2012	3
3/11/2012	19	3354.659	2012	3
3/11/2012	20	3258.248	2012	3
3/11/2012	21	3063.862	2012	3
3/11/2012	22	2943.863	2012	3
3/11/2012	23	2791.362	2012	3
3/12/2012	0	2740.962	2012	3
3/12/2012	1	2636.763	2012	3
3/12/2012	2	2673.762	2012	3
3/12/2012	3	2740.263	2012	3
3/12/2012	4	2933.062	2012	3
3/12/2012	5	3321.862	2012	3
3/12/2012	6	3685.663	2012	3
3/12/2012	7	3746.656	2012	3
3/12/2012	8	3767.748	2012	3
3/12/2012	9	3802.963	2012	3
3/12/2012	10	3797.362	2012	3
3/12/2012	11	3826.963	2012	3
3/12/2012	12	3823.862	2012	3
3/12/2012	13	3788.163	2012	3

Day	Hr	Total	Year	Month
3/12/2012	14	3718.763	2012	3
3/12/2012	15	3665.962	2012	3
3/12/2012	16	3703.563	2012	3
3/12/2012	17	3709.263	2012	3
3/12/2012	18	3740.063	2012	3
3/12/2012	19	3864.053	2012	3
3/12/2012	20	3675.153	2012	3
3/12/2012	21	3476.462	2012	3
3/12/2012	22	3204.263	2012	3
3/12/2012	23	3007.862	2012	3
3/13/2012	0	2903.062	2012	3
3/13/2012	1	2889.863	2012	3
3/13/2012	2	2781.662	2012	3
3/13/2012	3	2846.763	2012	3
3/13/2012	4	2974.03	2012	3
3/13/2012	5	3327.963	2012	3
3/13/2012	6	3662.962	2012	3
3/13/2012	7	3662.153	2012	3
3/13/2012	8	3668.154	2012	3
3/13/2012	9	3719.563	2012	3
3/13/2012	10	3741.969	2012	3
3/13/2012	11	3761.669	2012	3
3/13/2012	12	3780.669	2012	3
3/13/2012	13	3794.473	2012	3
3/13/2012	14	3795.775	2012	3
3/13/2012	15	3779.975	2012	3
3/13/2012	16	3755.976	2012	3
3/13/2012	17	3707.775	2012	3
3/13/2012	18	3733.275	2012	3
3/13/2012	19	3949.069	2012	3
3/13/2012	20	3827.868	2012	3
3/13/2012	21	3558.467	2012	3
3/13/2012	22	3293.367	2012	3
3/13/2012	23	3069.065	2012	3
3/14/2012	0	2905.464	2012	3
3/14/2012	1	2820.163	2012	3
3/14/2012	2	2747.851	2012	3
3/14/2012	3	2756.753	2012	3
3/14/2012	4	2892.062	2012	3
3/14/2012	5	3269.963	2012	3
3/14/2012	6	3639.762	2012	3
3/14/2012	7	3660.463	2012	3
3/14/2012	8	3692.267	2012	3
3/14/2012	9	3762.2	2012	3
3/14/2012	10	3797.646	2012	3
3/14/2012	11	3868.075	2012	3
3/14/2012	12	3903.576	2012	3
3/14/2012	13	3929.176	2012	3
3/14/2012	14	3970.275	2012	3
3/14/2012	15	3942.376	2012	3
3/14/2012	16	3948.076	2012	3
3/14/2012	17	3878.374	2012	3
3/14/2012	18	3851.275	2012	3
3/14/2012	19	4037.874	2012	3
3/14/2012	20	3885.572	2012	3
3/14/2012	21	3619.17	2012	3
3/14/2012	22	3375.869	2012	3
3/14/2012	23	3122.468	2012	3
3/15/2012	0	3035.669	2012	3
3/15/2012	1	2889.768	2012	3
3/15/2012	2	2800.852	2012	3
3/15/2012	3	2818.262	2012	3
3/15/2012	4	2990.266	2012	3
3/15/2012	5	3389.867	2012	3

Day	Hr	Total	Year	Month
3/15/2012	6	3685.966	2012	3
3/15/2012	7	3690.166	2012	3
3/15/2012	8	3744.568	2012	3
3/15/2012	9	3839.968	2012	3
3/15/2012	10	3887.069	2012	3
3/15/2012	11	3965.075	2012	3
3/15/2012	12	4070.377	2012	3
3/15/2012	13	4135.576	2012	3
3/15/2012	14	4176.875	2012	3
3/15/2012	15	4047.675	2012	3
3/15/2012	16	3937.572	2012	3
3/15/2012	17	3926.469	2012	3
3/15/2012	18	3827.164	2012	3
3/15/2012	19	3829.463	2012	3
3/15/2012	20	3769.867	2012	3
3/15/2012	21	3528.766	2012	3
3/15/2012	22	3280.363	2012	3
3/15/2012	23	3118.248	2012	3
3/16/2012	0	2939.756	2012	3
3/16/2012	1	2863.363	2012	3
3/16/2012	2	2741.662	2012	3
3/16/2012	3	2741.063	2012	3
3/16/2012	4	2893.563	2012	3
3/16/2012	5	3214.762	2012	3
3/16/2012	6	3516.963	2012	3
3/16/2012	7	3587.763	2012	3
3/16/2012	8	3690.668	2012	3
3/16/2012	9	3746.867	2012	3
3/16/2012	10	3784.868	2012	3
3/16/2012	11	3786.967	2012	3
3/16/2012	12	3786.768	2012	3
3/16/2012	13	3769.767	2012	3
3/16/2012	14	3708.651	2012	3
3/16/2012	15	3639.466	2012	3
3/16/2012	16	3617.269	2012	3
3/16/2012	17	3551.068	2012	3
3/16/2012	18	3565.668	2012	3
3/16/2012	19	3713.568	2012	3
3/16/2012	20	3619.368	2012	3
3/16/2012	21	3419.266	2012	3
3/16/2012	22	3231.467	2012	3
3/16/2012	23	2985.966	2012	3
3/17/2012	0	2848.266	2012	3
3/17/2012	1	2766.966	2012	3
3/17/2012	2	2666.065	2012	3
3/17/2012	3	2648.564	2012	3
3/17/2012	4	2644.266	2012	3
3/17/2012	5	2741.762	2012	3
3/17/2012	6	2902.452	2012	3
3/17/2012	7	2976.952	2012	3
3/17/2012	8	3154.166	2012	3
3/17/2012	9	3301.468	2012	3
3/17/2012	10	3324.571	2012	3
3/17/2012	11	3413.775	2012	3
3/17/2012	12	3432.074	2012	3
3/17/2012	13	3418.971	2012	3
3/17/2012	14	3416.976	2012	3
3/17/2012	15	3467.174	2012	3
3/17/2012	16	3466.175	2012	3
3/17/2012	17	3432.57	2012	3
3/17/2012	18	3462.668	2012	3
3/17/2012	19	3512.468	2012	3
3/17/2012	20	3404.266	2012	3
3/17/2012	21	3227.566	2012	3

Day	Hr	Total	Year	Month
3/17/2012	22	3049.166	2012	3
3/17/2012	23	2839.666	2012	3
3/18/2012	0	2696.764	2012	3
3/18/2012	1	2530.761	2012	3
3/18/2012	2	2515.048	2012	3
3/18/2012	3	2471.466	2012	3
3/18/2012	4	2477.066	2012	3
3/18/2012	5	2519.965	2012	3
3/18/2012	6	2662.566	2012	3
3/18/2012	7	2733.567	2012	3
3/18/2012	8	2939.768	2012	3
3/18/2012	9	3068.467	2012	3
3/18/2012	10	3199.269	2012	3
3/18/2012	11	3297.576	2012	3
3/18/2012	12	3350.076	2012	3
3/18/2012	13	3431.776	2012	3
3/18/2012	14	3509.576	2012	3
3/18/2012	15	3565.476	2012	3
3/18/2012	16	3606.276	2012	3
3/18/2012	17	3631.175	2012	3
3/18/2012	18	3604.175	2012	3
3/18/2012	19	3795.273	2012	3
3/18/2012	20	3681.273	2012	3
3/18/2012	21	3472.771	2012	3
3/18/2012	22	3193.171	2012	3
3/18/2012	23	2952.172	2012	3
3/19/2012	0	2756.268	2012	3
3/19/2012	1	2724.169	2012	3
3/19/2012	2	2723.668	2012	3
3/19/2012	3	2749.369	2012	3
3/19/2012	4	2935.66	2012	3
3/19/2012	5	3333.854	2012	3
3/19/2012	6	3624.468	2012	3
3/19/2012	7	3671.069	2012	3
3/19/2012	8	3759.969	2012	3
3/19/2012	9	3873.771	2012	3
3/19/2012	10	3974.177	2012	3
3/19/2012	11	4103.376	2012	3
3/19/2012	12	4249.177	2012	3
3/19/2012	13	4364.576	2012	3
3/19/2012	14	4381.276	2012	3
3/19/2012	15	4404.277	2012	3
3/19/2012	16	4392.376	2012	3
3/19/2012	17	4340.875	2012	3
3/19/2012	18	4263.976	2012	3
3/19/2012	19	4334.175	2012	3
3/19/2012	20	4175.174	2012	3
3/19/2012	21	3889.073	2012	3
3/19/2012	22	3572.671	2012	3
3/19/2012	23	3260.468	2012	3
3/20/2012	0	3066.369	2012	3
3/20/2012	1	2891.467	2012	3
3/20/2012	2	2823.469	2012	3
3/20/2012	3	2793.468	2012	3
3/20/2012	4	2961.668	2012	3
3/20/2012	5	3348.169	2012	3
3/20/2012	6	3650.368	2012	3
3/20/2012	7	3688.268	2012	3
3/20/2012	8	3779.769	2012	3
3/20/2012	9	3904.752	2012	3
3/20/2012	10	4033.967	2012	3
3/20/2012	11	4191.176	2012	3
3/20/2012	12	4337.977	2012	3
3/20/2012	13	4441.077	2012	3

Day	Hr	Total	Year	Month
3/20/2012	14	4520.676	2012	3
3/20/2012	15	4579.177	2012	3
3/20/2012	16	4577.077	2012	3
3/20/2012	17	4510.776	2012	3
3/20/2012	18	4423.176	2012	3
3/20/2012	19	4513.076	2012	3
3/20/2012	20	4322.375	2012	3
3/20/2012	21	3968.775	2012	3
3/20/2012	22	3592.074	2012	3
3/20/2012	23	3318.872	2012	3
3/21/2012	0	3125.274	2012	3
3/21/2012	1	2962.668	2012	3
3/21/2012	2	2863.273	2012	3
3/21/2012	3	2851.468	2012	3
3/21/2012	4	2974.869	2012	3
3/21/2012	5	3357.168	2012	3
3/21/2012	6	3666.267	2012	3
3/21/2012	7	3701.268	2012	3
3/21/2012	8	3831.368	2012	3
3/21/2012	9	4009.87	2012	3
3/21/2012	10	4168.171	2012	3
3/21/2012	11	4328.076	2012	3
3/21/2012	12	4483.476	2012	3
3/21/2012	13	4595.076	2012	3
3/21/2012	14	4674.877	2012	3
3/21/2012	15	4686.677	2012	3
3/21/2012	16	4673.976	2012	3
3/21/2012	17	4575.976	2012	3
3/21/2012	18	4437.676	2012	3
3/21/2012	19	4508.876	2012	3
3/21/2012	20	4316.475	2012	3
3/21/2012	21	3972.374	2012	3
3/21/2012	22	3600.772	2012	3
3/21/2012	23	3296.173	2012	3
3/22/2012	0	3098.869	2012	3
3/22/2012	1	2940.169	2012	3
3/22/2012	2	2863.168	2012	3
3/22/2012	3	2821.657	2012	3
3/22/2012	4	2938.356	2012	3
3/22/2012	5	3326.867	2012	3
3/22/2012	6	3611.168	2012	3
3/22/2012	7	3657.367	2012	3
3/22/2012	8	3800.869	2012	3
3/22/2012	9	3945.169	2012	3
3/22/2012	10	4095.469	2012	3
3/22/2012	11	4231.074	2012	3
3/22/2012	12	4335.876	2012	3
3/22/2012	13	4418.176	2012	3
3/22/2012	14	4405.388	2012	3
3/22/2012	15	4351.475	2012	3
3/22/2012	16	4316.477	2012	3
3/22/2012	17	4187.375	2012	3
3/22/2012	18	4154.375	2012	3
3/22/2012	19	4232.174	2012	3
3/22/2012	20	4097.07	2012	3
3/22/2012	21	3826.772	2012	3
3/22/2012	22	3500.271	2012	3
3/22/2012	23	3247.269	2012	3
3/23/2012	0	3058.268	2012	3
3/23/2012	1	2924.873	2012	3
3/23/2012	2	2855.268	2012	3
3/23/2012	3	2833.568	2012	3
3/23/2012	4	3008.668	2012	3
3/23/2012	5	3334.368	2012	3

Day	Hr	Total	Year	Month
3/23/2012	6	3689.068	2012	3
3/23/2012	7	3718.368	2012	3
3/23/2012	8	3819.668	2012	3
3/23/2012	9	3922.868	2012	3
3/23/2012	10	3937.068	2012	3
3/23/2012	11	3973.953	2012	3
3/23/2012	12	4021.461	2012	3
3/23/2012	13	3966.068	2012	3
3/23/2012	14	3929.368	2012	3
3/23/2012	15	3912.769	2012	3
3/23/2012	16	3943.673	2012	3
3/23/2012	17	3913.568	2012	3
3/23/2012	18	3811.87	2012	3
3/23/2012	19	3892.872	2012	3
3/23/2012	20	3743.665	2012	3
3/23/2012	21	3484.566	2012	3
3/23/2012	22	3302.163	2012	3
3/23/2012	23	3079.967	2012	3
3/24/2012	0	2871.264	2012	3
3/24/2012	1	2774.865	2012	3
3/24/2012	2	2652.563	2012	3
3/24/2012	3	2628.963	2012	3
3/24/2012	4	2624.262	2012	3
3/24/2012	5	2718.548	2012	3
3/24/2012	6	2866.157	2012	3
3/24/2012	7	2962.863	2012	3
3/24/2012	8	3138.263	2012	3
3/24/2012	9	3233.368	2012	3
3/24/2012	10	3295.068	2012	3
3/24/2012	11	3259.469	2012	3
3/24/2012	12	3274.769	2012	3
3/24/2012	13	3162.067	2012	3
3/24/2012	14	3156.066	2012	3
3/24/2012	15	3153.369	2012	3
3/24/2012	16	3173.269	2012	3
3/24/2012	17	3159.669	2012	3
3/24/2012	18	3140.468	2012	3
3/24/2012	19	3311.767	2012	3
3/24/2012	20	3212.968	2012	3
3/24/2012	21	2998.759	2012	3
3/24/2012	22	2855.75	2012	3
3/24/2012	23	2694.262	2012	3
3/25/2012	0	2537.963	2012	3
3/25/2012	1	2456.662	2012	3
3/25/2012	2	2447.463	2012	3
3/25/2012	3	2392.363	2012	3
3/25/2012	4	2475.162	2012	3
3/25/2012	5	2529.063	2012	3
3/25/2012	6	2632.163	2012	3
3/25/2012	7	2695.564	2012	3
3/25/2012	8	2850.267	2012	3
3/25/2012	9	2918.768	2012	3
3/25/2012	10	2958.667	2012	3
3/25/2012	11	2982.514	2012	3
3/25/2012	12	2991.86	2012	3
3/25/2012	13	2975.145	2012	3
3/25/2012	14	3041.77	2012	3
3/25/2012	15	3061.301	2012	3
3/25/2012	16	3100.87	2012	3
3/25/2012	17	3126.769	2012	3
3/25/2012	18	3199.969	2012	3
3/25/2012	19	3355.969	2012	3
3/25/2012	20	3293.068	2012	3
3/25/2012	21	3171.668	2012	3

Day	Hr	Total	Year	Month
3/25/2012	22	2926.768	2012	3
3/25/2012	23	2762.866	2012	3
3/26/2012	0	2684.767	2012	3
3/26/2012	1	2555.863	2012	3
3/26/2012	2	2562.063	2012	3
3/26/2012	3	2618.863	2012	3
3/26/2012	4	2842.463	2012	3
3/26/2012	5	3225.049	2012	3
3/26/2012	6	3543.755	2012	3
3/26/2012	7	3563.763	2012	3
3/26/2012	8	3636.161	2012	3
3/26/2012	9	3705.464	2012	3
3/26/2012	10	3712.869	2012	3
3/26/2012	11	3722.168	2012	3
3/26/2012	12	3748.769	2012	3
3/26/2012	13	3721.369	2012	3
3/26/2012	14	3690.668	2012	3
3/26/2012	15	3709.069	2012	3
3/26/2012	16	3662.669	2012	3
3/26/2012	17	3651.067	2012	3
3/26/2012	18	3605.556	2012	3
3/26/2012	19	3818.951	2012	3
3/26/2012	20	3719.863	2012	3
3/26/2012	21	3476.662	2012	3
3/26/2012	22	3210.063	2012	3
3/26/2012	23	3062.963	2012	3
3/27/2012	0	2917.763	2012	3
3/27/2012	1	2833.463	2012	3
3/27/2012	2	2841.258	2012	3
3/27/2012	3	2920.848	2012	3
3/27/2012	4	3065.863	2012	3
3/27/2012	5	3564.463	2012	3
3/27/2012	6	3895.263	2012	3
3/27/2012	7	3866.834	2012	3
3/27/2012	8	3846.626	2012	3
3/27/2012	9	3802.07	2012	3
3/27/2012	10	3763.059	2012	3
3/27/2012	11	3740.705	2012	3
3/27/2012	12	3701.652	2012	3
3/27/2012	13	3706.421	2012	3
3/27/2012	14	3649.481	2012	3
3/27/2012	15	3627.106	2012	3
3/27/2012	16	3588.269	2012	3
3/27/2012	17	3591.07	2012	3
3/27/2012	18	3590.369	2012	3
3/27/2012	19	3784.769	2012	3
3/27/2012	20	3704.668	2012	3
3/27/2012	21	3465.067	2012	3
3/27/2012	22	3188.165	2012	3
3/27/2012	23	2974.067	2012	3
3/28/2012	0	2821.263	2012	3
3/28/2012	1	2787.066	2012	3
3/28/2012	2	2702.764	2012	3
3/28/2012	3	2747.447	2012	3
3/28/2012	4	2895.959	2012	3
3/28/2012	5	3368.463	2012	3
3/28/2012	6	3590.363	2012	3
3/28/2012	7	3633.467	2012	3
3/28/2012	8	3715.767	2012	3
3/28/2012	9	3793.669	2012	3
3/28/2012	10	3805.571	2012	3
3/28/2012	11	3946.981	2012	3
3/28/2012	12	4065.777	2012	3
3/28/2012	13	4160.776	2012	3

Day	Hr	Total	Year	Month
3/28/2012	14	4092.872	2012	3
3/28/2012	15	4117.875	2012	3
3/28/2012	16	4052.875	2012	3
3/28/2012	17	4019.576	2012	3
3/28/2012	18	3894.975	2012	3
3/28/2012	19	4002.173	2012	3
3/28/2012	20	3902.071	2012	3
3/28/2012	21	3607.968	2012	3
3/28/2012	22	3289.468	2012	3
3/28/2012	23	3093.566	2012	3
3/29/2012	0	2884.265	2012	3
3/29/2012	1	2813.566	2012	3
3/29/2012	2	2779.85	2012	3
3/29/2012	3	2695.955	2012	3
3/29/2012	4	2896.363	2012	3
3/29/2012	5	3279.563	2012	3
3/29/2012	6	3517.363	2012	3
3/29/2012	7	3566.064	2012	3
3/29/2012	8	3642.449	2012	3
3/29/2012	9	3706.967	2012	3
3/29/2012	10	3725.969	2012	3
3/29/2012	11	3771.97	2012	3
3/29/2012	12	3872.069	2012	3
3/29/2012	13	3861.173	2012	3
3/29/2012	14	3834.768	2012	3
3/29/2012	15	3836.973	2012	3
3/29/2012	16	3913.275	2012	3
3/29/2012	17	3761.473	2012	3
3/29/2012	18	3715.87	2012	3
3/29/2012	19	3902.013	2012	3
3/29/2012	20	3845.358	2012	3
3/29/2012	21	3508.557	2012	3
3/29/2012	22	3261.865	2012	3
3/29/2012	23	2993.266	2012	3
3/30/2012	0	2893.063	2012	3
3/30/2012	1	2745.267	2012	3
3/30/2012	2	2715.663	2012	3
3/30/2012	3	2694.767	2012	3
3/30/2012	4	2892.764	2012	3
3/30/2012	5	3212.066	2012	3
3/30/2012	6	3521.463	2012	3
3/30/2012	7	3506.967	2012	3
3/30/2012	8	3620.753	2012	3
3/30/2012	9	3675.892	2012	3
3/30/2012	10	3717.737	2012	3
3/30/2012	11	3830.195	2012	3
3/30/2012	12	3970.376	2012	3
3/30/2012	13	3965.976	2012	3
3/30/2012	14	4022.176	2012	3
3/30/2012	15	4020.176	2012	3
3/30/2012	16	4023.274	2012	3
3/30/2012	17	3968.275	2012	3
3/30/2012	18	3792.869	2012	3
3/30/2012	19	3880.153	2012	3
3/30/2012	20	3804.365	2012	3
3/30/2012	21	3581.869	2012	3
3/30/2012	22	3338.769	2012	3
3/30/2012	23	3112.968	2012	3
3/31/2012	0	2860.367	2012	3
3/31/2012	1	2767.666	2012	3
3/31/2012	2	2690.267	2012	3
3/31/2012	3	2611.167	2012	3
3/31/2012	4	2659.467	2012	3
3/31/2012	5	2746.466	2012	3

Day	Hr	Total	Year	Month
3/31/2012	6	2785.366	2012	3
3/31/2012	7	2917.864	2012	3
3/31/2012	8	3064.075	2012	3
3/31/2012	9	3194.363	2012	3
3/31/2012	10	3256.753	2012	3
3/31/2012	11	3242.154	2012	3
3/31/2012	12	3250.968	2012	3
3/31/2012	13	3211.368	2012	3
3/31/2012	14	3250.47	2012	3
3/31/2012	15	3265.369	2012	3
3/31/2012	16	3248.17	2012	3
3/31/2012	17	3137.369	2012	3
3/31/2012	18	3069.969	2012	3
3/31/2012	19	3160.368	2012	3
3/31/2012	20	3163.263	2012	3
3/31/2012	21	3001.363	2012	3
3/31/2012	22	2825.463	2012	3
3/31/2012	23	2662.559	2012	3
4/1/2012	0	2495.661	2012	4
4/1/2012	1	2409.446	2012	4
4/1/2012	2	2413.962	2012	4
4/1/2012	3	2377.062	2012	4
4/1/2012	4	2488.763	2012	4
4/1/2012	5	2589.663	2012	4
4/1/2012	6	2653.063	2012	4
4/1/2012	7	2834.463	2012	4
4/1/2012	8	2976.263	2012	4
4/1/2012	9	3065.463	2012	4
4/1/2012	10	3104.563	2012	4
4/1/2012	11	3096.063	2012	4
4/1/2012	12	3071.555	2012	4
4/1/2012	13	3080.771	2012	4
4/1/2012	14	3038.869	2012	4
4/1/2012	15	3069.97	2012	4
4/1/2012	16	3196.57	2012	4
4/1/2012	17	3189.47	2012	4
4/1/2012	18	3278.87	2012	4
4/1/2012	19	3440.075	2012	4
4/1/2012	20	3419.369	2012	4
4/1/2012	21	3222.869	2012	4
4/1/2012	22	3017.069	2012	4
4/1/2012	23	2833.369	2012	4
4/2/2012	0	2735.767	2012	4
4/2/2012	1	2691.968	2012	4
4/2/2012	2	2642.468	2012	4
4/2/2012	3	2658.469	2012	4
4/2/2012	4	2811.968	2012	4
4/2/2012	5	3179.769	2012	4
4/2/2012	6	3447.167	2012	4
4/2/2012	7	3545.866	2012	4
4/2/2012	8	3666.148	2012	4
4/2/2012	9	3787.661	2012	4
4/2/2012	10	3811.067	2012	4
4/2/2012	11	3872.369	2012	4
4/2/2012	12	3909.869	2012	4
4/2/2012	13	3958.97	2012	4
4/2/2012	14	3983.169	2012	4
4/2/2012	15	3958.77	2012	4
4/2/2012	16	3954.269	2012	4
4/2/2012	17	3925.569	2012	4
4/2/2012	18	3916.869	2012	4
4/2/2012	19	4003.969	2012	4
4/2/2012	20	3823.768	2012	4
4/2/2012	21	3613.769	2012	4

Day	Hr	Total	Year	Month
4/2/2012	22	3331.569	2012	4
4/2/2012	23	3174.668	2012	4
4/3/2012	0	2966.767	2012	4
4/3/2012	1	2873.067	2012	4
4/3/2012	2	2791.256	2012	4
4/3/2012	3	2757.054	2012	4
4/3/2012	4	2924.167	2012	4
4/3/2012	5	3196.964	2012	4
4/3/2012	6	3441.166	2012	4
4/3/2012	7	3526.666	2012	4
4/3/2012	8	3664.393	2012	4
4/3/2012	9	3784.676	2012	4
4/3/2012	10	3899.977	2012	4
4/3/2012	11	4071.543	2012	4
4/3/2012	12	4247.277	2012	4
4/3/2012	13	4443.777	2012	4
4/3/2012	14	4486.477	2012	4
4/3/2012	15	4536.937	2012	4
4/3/2012	16	4481.077	2012	4
4/3/2012	17	4420.878	2012	4
4/3/2012	18	4364.777	2012	4
4/3/2012	19	4447.776	2012	4
4/3/2012	20	4287.875	2012	4
4/3/2012	21	3900.675	2012	4
4/3/2012	22	3631.475	2012	4
4/3/2012	23	3353.975	2012	4
4/4/2012	0	3178.769	2012	4
4/4/2012	1	3063.474	2012	4
4/4/2012	2	2946.97	2012	4
4/4/2012	3	2902.669	2012	4
4/4/2012	4	3076.968	2012	4
4/4/2012	5	3345.569	2012	4
4/4/2012	6	3595.469	2012	4
4/4/2012	7	3657.069	2012	4
4/4/2012	8	3809.975	2012	4
4/4/2012	9	4000.775	2012	4
4/4/2012	10	4103.175	2012	4
4/4/2012	11	4225.876	2012	4
4/4/2012	12	4344.876	2012	4
4/4/2012	13	4378.977	2012	4
4/4/2012	14	4423.577	2012	4
4/4/2012	15	4301.776	2012	4
4/4/2012	16	4174.862	2012	4
4/4/2012	17	4068.455	2012	4
4/4/2012	18	3957.668	2012	4
4/4/2012	19	4044.067	2012	4
4/4/2012	20	3907.364	2012	4
4/4/2012	21	3609.066	2012	4
4/4/2012	22	3371.564	2012	4
4/4/2012	23	3149.467	2012	4
4/5/2012	0	2995.163	2012	4
4/5/2012	1	2847.662	2012	4
4/5/2012	2	2750.763	2012	4
4/5/2012	3	2733.463	2012	4
4/5/2012	4	2871.256	2012	4
4/5/2012	5	3219.05	2012	4
4/5/2012	6	3433.663	2012	4
4/5/2012	7	3533.864	2012	4
4/5/2012	8	3613.363	2012	4
4/5/2012	9	3665.563	2012	4
4/5/2012	10	3661.464	2012	4
4/5/2012	11	3667.463	2012	4
4/5/2012	12	3705.563	2012	4
4/5/2012	13	3699.262	2012	4

Case No. 2018-00295
Attachment 5 to Response to Metro-1 Question No. 37(b)
Page 37 of 823
Bellar

Day	Hr	Total	Year	Month
4/5/2012	14	3642.946	2012	4
4/5/2012	15	3553.262	2012	4
4/5/2012	16	3554.163	2012	4
4/5/2012	17	3483.364	2012	4
4/5/2012	18	3417.163	2012	4
4/5/2012	19	3665.563	2012	4
4/5/2012	20	3597.663	2012	4
4/5/2012	21	3366.463	2012	4
4/5/2012	22	3190.759	2012	4
4/5/2012	23	2990.747	2012	4
4/6/2012	0	2844.863	2012	4
4/6/2012	1	2803.063	2012	4
4/6/2012	2	2761.662	2012	4
4/6/2012	3	2782.063	2012	4
4/6/2012	4	2897.663	2012	4
4/6/2012	5	3216.046	2012	4
4/6/2012	6	3386.861	2012	4
4/6/2012	7	3510.663	2012	4
4/6/2012	8	3500.663	2012	4
4/6/2012	9	3504.263	2012	4
4/6/2012	10	3418.664	2012	4
4/6/2012	11	3409.362	2012	4
4/6/2012	12	3397.051	2012	4
4/6/2012	13	3350.159	2012	4
4/6/2012	14	3310.363	2012	4
4/6/2012	15	3175.463	2012	4
4/6/2012	16	3212.464	2012	4
4/6/2012	17	3145.563	2012	4
4/6/2012	18	3135.563	2012	4
4/6/2012	19	3268.463	2012	4
4/6/2012	20	3298.162	2012	4
4/6/2012	21	3136.646	2012	4
4/6/2012	22	3021.863	2012	4
4/6/2012	23	2875.063	2012	4
4/7/2012	0	2786.763	2012	4
4/7/2012	1	2693.362	2012	4
4/7/2012	2	2702.163	2012	4
4/7/2012	3	2721.263	2012	4
4/7/2012	4	2786.862	2012	4
4/7/2012	5	2909.861	2012	4
4/7/2012	6	3010.847	2012	4
4/7/2012	7	3091.263	2012	4
4/7/2012	8	3183.563	2012	4
4/7/2012	9	3126.463	2012	4
4/7/2012	10	3051.763	2012	4
4/7/2012	11	2994.364	2012	4
4/7/2012	12	3031.934	2012	4
4/7/2012	13	2968.87	2012	4
4/7/2012	14	2978.869	2012	4
4/7/2012	15	2958.37	2012	4
4/7/2012	16	3014.169	2012	4
4/7/2012	17	3013.77	2012	4
4/7/2012	18	2964.769	2012	4
4/7/2012	19	3125.168	2012	4
4/7/2012	20	3115.464	2012	4
4/7/2012	21	2947.251	2012	4
4/7/2012	22	2809.26	2012	4
4/7/2012	23	2661.163	2012	4
4/8/2012	0	2535.063	2012	4
4/8/2012	1	2425.663	2012	4
4/8/2012	2	2428.763	2012	4
4/8/2012	3	2451.863	2012	4
4/8/2012	4	2500.663	2012	4
4/8/2012	5	2576.498	2012	4

Day	Hr	Total	Year	Month
4/8/2012	6	2645.263	2012	4
4/8/2012	7	2796.763	2012	4
4/8/2012	8	2892.163	2012	4
4/8/2012	9	2863.368	2012	4
4/8/2012	10	2876.565	2012	4
4/8/2012	11	2864.454	2012	4
4/8/2012	12	2843.569	2012	4
4/8/2012	13	2798.67	2012	4
4/8/2012	14	2765.369	2012	4
4/8/2012	15	2757.17	2012	4
4/8/2012	16	2806.769	2012	4
4/8/2012	17	2859.769	2012	4
4/8/2012	18	2845.369	2012	4
4/8/2012	19	3073.468	2012	4
4/8/2012	20	3096.765	2012	4
4/8/2012	21	2955.463	2012	4
4/8/2012	22	2769.263	2012	4
4/8/2012	23	2673.063	2012	4
4/9/2012	0	2595.663	2012	4
4/9/2012	1	2542.46	2012	4
4/9/2012	2	2561.246	2012	4
4/9/2012	3	2715.563	2012	4
4/9/2012	4	2892.263	2012	4
4/9/2012	5	3328.263	2012	4
4/9/2012	6	3585.602	2012	4
4/9/2012	7	3667.163	2012	4
4/9/2012	8	3701.263	2012	4
4/9/2012	9	3741.468	2012	4
4/9/2012	10	3714.368	2012	4
4/9/2012	11	3735.369	2012	4
4/9/2012	12	3765.469	2012	4
4/9/2012	13	3729.77	2012	4
4/9/2012	14	3669.869	2012	4
4/9/2012	15	3584.269	2012	4
4/9/2012	16	3543.969	2012	4
4/9/2012	17	3513.568	2012	4
4/9/2012	18	3563.36	2012	4
4/9/2012	19	3721.757	2012	4
4/9/2012	20	3697.266	2012	4
4/9/2012	21	3465.965	2012	4
4/9/2012	22	3219.565	2012	4
4/9/2012	23	3019.763	2012	4
4/10/2012	0	2961.863	2012	4
4/10/2012	1	2842.263	2012	4
4/10/2012	2	2826.663	2012	4
4/10/2012	3	2843.363	2012	4
4/10/2012	4	3009.164	2012	4
4/10/2012	5	3429.962	2012	4
4/10/2012	6	3629.264	2012	4
4/10/2012	7	3714.363	2012	4
4/10/2012	8	3727.552	2012	4
4/10/2012	9	3767.955	2012	4
4/10/2012	10	3766.768	2012	4
4/10/2012	11	3743.367	2012	4
4/10/2012	12	3793.568	2012	4
4/10/2012	13	3705.464	2012	4
4/10/2012	14	3646.663	2012	4
4/10/2012	15	3530.563	2012	4
4/10/2012	16	3552.264	2012	4
4/10/2012	17	3549.663	2012	4
4/10/2012	18	3540.264	2012	4
4/10/2012	19	3764.663	2012	4
4/10/2012	20	3774.563	2012	4
4/10/2012	21	3555.463	2012	4

Day	Hr	Total	Year	Month
4/10/2012	22	3296.054	2012	4
4/10/2012	23	3150.251	2012	4
4/11/2012	0	3109.082	2012	4
4/11/2012	1	3098.362	2012	4
4/11/2012	2	3068.963	2012	4
4/11/2012	3	3145.863	2012	4
4/11/2012	4	3412.362	2012	4
4/11/2012	5	3789.463	2012	4
4/11/2012	6	3991.748	2012	4
4/11/2012	7	4012.858	2012	4
4/11/2012	8	3987.563	2012	4
4/11/2012	9	3985.863	2012	4
4/11/2012	10	3980.863	2012	4
4/11/2012	11	3921.564	2012	4
4/11/2012	12	3887.263	2012	4
4/11/2012	13	3825.463	2012	4
4/11/2012	14	3700.062	2012	4
4/11/2012	15	3726.647	2012	4
4/11/2012	16	3711.063	2012	4
4/11/2012	17	3717.863	2012	4
4/11/2012	18	3675.963	2012	4
4/11/2012	19	3924.963	2012	4
4/11/2012	20	3901.663	2012	4
4/11/2012	21	3720.663	2012	4
4/11/2012	22	3589.763	2012	4
4/11/2012	23	3441.763	2012	4
4/12/2012	0	3342.346	2012	4
4/12/2012	1	3349.961	2012	4
4/12/2012	2	3308.263	2012	4
4/12/2012	3	3349.662	2012	4
4/12/2012	4	3584.763	2012	4
4/12/2012	5	3971.862	2012	4
4/12/2012	6	4238.563	2012	4
4/12/2012	7	4182.156	2012	4
4/12/2012	8	4079.453	2012	4
4/12/2012	9	3937.963	2012	4
4/12/2012	10	3866.164	2012	4
4/12/2012	11	3816.163	2012	4
4/12/2012	12	3764.863	2012	4
4/12/2012	13	3729.865	2012	4
4/12/2012	14	3655.269	2012	4
4/12/2012	15	3602.97	2012	4
4/12/2012	16	3545.006	2012	4
4/12/2012	17	3548.069	2012	4
4/12/2012	18	3558.468	2012	4
4/12/2012	19	3716.463	2012	4
4/12/2012	20	3673.562	2012	4
4/12/2012	21	3486.147	2012	4
4/12/2012	22	3286.172	2012	4
4/12/2012	23	3111.863	2012	4
4/13/2012	0	3045.763	2012	4
4/13/2012	1	3075.662	2012	4
4/13/2012	2	3094.763	2012	4
4/13/2012	3	3114.363	2012	4
4/13/2012	4	3283.762	2012	4
4/13/2012	5	3730.563	2012	4
4/13/2012	6	3926.95	2012	4
4/13/2012	7	3936.057	2012	4
4/13/2012	8	3868.463	2012	4
4/13/2012	9	3843.464	2012	4
4/13/2012	10	3762.267	2012	4
4/13/2012	11	3741.363	2012	4
4/13/2012	12	3717.566	2012	4
4/13/2012	13	3690.169	2012	4

Day	Hr	Total	Year	Month
4/13/2012	14	3605.869	2012	4
4/13/2012	15	3508.868	2012	4
4/13/2012	16	3491.566	2012	4
4/13/2012	17	3430.766	2012	4
4/13/2012	18	3387.268	2012	4
4/13/2012	19	3606.067	2012	4
4/13/2012	20	3521.967	2012	4
4/13/2012	21	3350.26	2012	4
4/13/2012	22	3183.046	2012	4
4/13/2012	23	2987.475	2012	4
4/14/2012	0	2849.462	2012	4
4/14/2012	1	2719.863	2012	4
4/14/2012	2	2662.563	2012	4
4/14/2012	3	2613.263	2012	4
4/14/2012	4	2708.663	2012	4
4/14/2012	5	2814.063	2012	4
4/14/2012	6	2878.863	2012	4
4/14/2012	7	3034.264	2012	4
4/14/2012	8	3200.563	2012	4
4/14/2012	9	3271.264	2012	4
4/14/2012	10	3266.759	2012	4
4/14/2012	11	3250.952	2012	4
4/14/2012	12	3200.668	2012	4
4/14/2012	13	3191.968	2012	4
4/14/2012	14	3186.069	2012	4
4/14/2012	15	3180.069	2012	4
4/14/2012	16	3175.869	2012	4
4/14/2012	17	3202.27	2012	4
4/14/2012	18	3206.969	2012	4
4/14/2012	19	3293.97	2012	4
4/14/2012	20	3317.068	2012	4
4/14/2012	21	3158.668	2012	4
4/14/2012	22	2963.367	2012	4
4/14/2012	23	2787.167	2012	4
4/15/2012	0	2618.768	2012	4
4/15/2012	1	2535.066	2012	4
4/15/2012	2	2478.865	2012	4
4/15/2012	3	2439.967	2012	4
4/15/2012	4	2469.465	2012	4
4/15/2012	5	2583.466	2012	4
4/15/2012	6	2593.668	2012	4
4/15/2012	7	2781.452	2012	4
4/15/2012	8	2868.666	2012	4
4/15/2012	9	3042.77	2012	4
4/15/2012	10	3204.469	2012	4
4/15/2012	11	3289.37	2012	4
4/15/2012	12	3352.07	2012	4
4/15/2012	13	3434.67	2012	4
4/15/2012	14	3484.676	2012	4
4/15/2012	15	3588.276	2012	4
4/15/2012	16	3646.473	2012	4
4/15/2012	17	3622.47	2012	4
4/15/2012	18	3595.869	2012	4
4/15/2012	19	3756.57	2012	4
4/15/2012	20	3716.269	2012	4
4/15/2012	21	3517.168	2012	4
4/15/2012	22	3269.369	2012	4
4/15/2012	23	3014.668	2012	4
4/16/2012	0	2912.268	2012	4
4/16/2012	1	2845.968	2012	4
4/16/2012	2	2781.167	2012	4
4/16/2012	3	2850.765	2012	4
4/16/2012	4	3036.968	2012	4
4/16/2012	5	3428.866	2012	4

Day	Hr	Total	Year	Month
4/16/2012	6	3677.867	2012	4
4/16/2012	7	3788.464	2012	4
4/16/2012	8	3877.063	2012	4
4/16/2012	9	3980.368	2012	4
4/16/2012	10	4018.698	2012	4
4/16/2012	11	4077.25	2012	4
4/16/2012	12	4128.967	2012	4
4/16/2012	13	4169.069	2012	4
4/16/2012	14	4140.87	2012	4
4/16/2012	15	4044.972	2012	4
4/16/2012	16	4058.373	2012	4
4/16/2012	17	3960.574	2012	4
4/16/2012	18	3901.173	2012	4
4/16/2012	19	3969.772	2012	4
4/16/2012	20	3917.571	2012	4
4/16/2012	21	3599.956	2012	4
4/16/2012	22	3304.067	2012	4
4/16/2012	23	3084.367	2012	4
4/17/2012	0	2900.666	2012	4
4/17/2012	1	2806.967	2012	4
4/17/2012	2	2757.667	2012	4
4/17/2012	3	2723.667	2012	4
4/17/2012	4	2909.963	2012	4
4/17/2012	5	3315.95	2012	4
4/17/2012	6	3533.766	2012	4
4/17/2012	7	3602.867	2012	4
4/17/2012	8	3679.268	2012	4
4/17/2012	9	3761.27	2012	4
4/17/2012	10	3776.673	2012	4
4/17/2012	11	3798.87	2012	4
4/17/2012	12	3845.069	2012	4
4/17/2012	13	3794.271	2012	4
4/17/2012	14	3746.172	2012	4
4/17/2012	15	3684.87	2012	4
4/17/2012	16	3671.544	2012	4
4/17/2012	17	3617.464	2012	4
4/17/2012	18	3654.156	2012	4
4/17/2012	19	3721.971	2012	4
4/17/2012	20	3712.967	2012	4
4/17/2012	21	3490.066	2012	4
4/17/2012	22	3262.867	2012	4
4/17/2012	23	3042.467	2012	4
4/18/2012	0	2948.767	2012	4
4/18/2012	1	2857.766	2012	4
4/18/2012	2	2804.767	2012	4
4/18/2012	3	2818.167	2012	4
4/18/2012	4	2998.464	2012	4
4/18/2012	5	3385.35	2012	4
4/18/2012	6	3553.367	2012	4
4/18/2012	7	3658.867	2012	4
4/18/2012	8	3691.672	2012	4
4/18/2012	9	3727.272	2012	4
4/18/2012	10	3753.373	2012	4
4/18/2012	11	3805.873	2012	4
4/18/2012	12	3816.874	2012	4
4/18/2012	13	3849.273	2012	4
4/18/2012	14	3872.574	2012	4
4/18/2012	15	3862.073	2012	4
4/18/2012	16	3823.472	2012	4
4/18/2012	17	3800.872	2012	4
4/18/2012	18	3783.573	2012	4
4/18/2012	19	3866.573	2012	4
4/18/2012	20	3848.364	2012	4
4/18/2012	21	3543.053	2012	4

Day	Hr	Total	Year	Month
4/18/2012	22	3291.466	2012	4
4/18/2012	23	3089.573	2012	4
4/19/2012	0	2949.567	2012	4
4/19/2012	1	2869.366	2012	4
4/19/2012	2	2788.267	2012	4
4/19/2012	3	2799.266	2012	4
4/19/2012	4	3020.067	2012	4
4/19/2012	5	3397.566	2012	4
4/19/2012	6	3624.16	2012	4
4/19/2012	7	3676.355	2012	4
4/19/2012	8	3752.271	2012	4
4/19/2012	9	3782.774	2012	4
4/19/2012	10	3800.276	2012	4
4/19/2012	11	3863.456	2012	4
4/19/2012	12	3899.679	2012	4
4/19/2012	13	3969.58	2012	4
4/19/2012	14	3978.278	2012	4
4/19/2012	15	4006.078	2012	4
4/19/2012	16	4001.378	2012	4
4/19/2012	17	3993.976	2012	4
4/19/2012	18	3952.973	2012	4
4/19/2012	19	3952.973	2012	4
4/19/2012	20	3955.273	2012	4
4/19/2012	21	3665.371	2012	4
4/19/2012	22	3338.371	2012	4
4/19/2012	23	3114.867	2012	4
4/20/2012	0	2961.962	2012	4
4/20/2012	1	2789.351	2012	4
4/20/2012	2	2733.166	2012	4
4/20/2012	3	2730.467	2012	4
4/20/2012	4	2919.467	2012	4
4/20/2012	5	3284.667	2012	4
4/20/2012	6	3471.767	2012	4
4/20/2012	7	3591.67	2012	4
4/20/2012	8	3686.672	2012	4
4/20/2012	9	3761.373	2012	4
4/20/2012	10	3858.17	2012	4
4/20/2012	11	3903.673	2012	4
4/20/2012	12	3990.473	2012	4
4/20/2012	13	4007.374	2012	4
4/20/2012	14	4003.279	2012	4
4/20/2012	15	4005.974	2012	4
4/20/2012	16	3914.473	2012	4
4/20/2012	17	3824.174	2012	4
4/20/2012	18	3751.469	2012	4
4/20/2012	19	3782.361	2012	4
4/20/2012	20	3742.556	2012	4
4/20/2012	21	3476.767	2012	4
4/20/2012	22	3232.366	2012	4
4/20/2012	23	2971.567	2012	4
4/21/2012	0	2832.967	2012	4
4/21/2012	1	2770.566	2012	4
4/21/2012	2	2648.667	2012	4
4/21/2012	3	2629.966	2012	4
4/21/2012	4	2647.167	2012	4
4/21/2012	5	2780.966	2012	4
4/21/2012	6	2833.458	2012	4
4/21/2012	7	3016.356	2012	4
4/21/2012	8	3182.267	2012	4
4/21/2012	9	3295.167	2012	4
4/21/2012	10	3319.467	2012	4
4/21/2012	11	3319.967	2012	4
4/21/2012	12	3265.167	2012	4
4/21/2012	13	3242.267	2012	4

Day	Hr	Total	Year	Month
4/21/2012	14	3200.567	2012	4
4/21/2012	15	3129.45	2012	4
4/21/2012	16	3137.065	2012	4
4/21/2012	17	3187.267	2012	4
4/21/2012	18	3244.967	2012	4
4/21/2012	19	3329.967	2012	4
4/21/2012	20	3277.766	2012	4
4/21/2012	21	3151.567	2012	4
4/21/2012	22	2967.366	2012	4
4/21/2012	23	2810.45	2012	4
4/22/2012	0	2769.165	2012	4
4/22/2012	1	2659.565	2012	4
4/22/2012	2	2658.666	2012	4
4/22/2012	3	2654.766	2012	4
4/22/2012	4	2714.166	2012	4
4/22/2012	5	2695.066	2012	4
4/22/2012	6	2834.851	2012	4
4/22/2012	7	3071.664	2012	4
4/22/2012	8	3135.367	2012	4
4/22/2012	9	3177.367	2012	4
4/22/2012	10	3218.667	2012	4
4/22/2012	11	3237.668	2012	4
4/22/2012	12	3213.867	2012	4
4/22/2012	13	3158.067	2012	4
4/22/2012	14	3159.35	2012	4
4/22/2012	15	3199.765	2012	4
4/22/2012	16	3178.367	2012	4
4/22/2012	17	3209.766	2012	4
4/22/2012	18	3310.667	2012	4
4/22/2012	19	3465.866	2012	4
4/22/2012	20	3504.053	2012	4
4/22/2012	21	3333.265	2012	4
4/22/2012	22	3139.249	2012	4
4/22/2012	23	2993.865	2012	4
4/23/2012	0	2992.366	2012	4
4/23/2012	1	2962.165	2012	4
4/23/2012	2	2982.366	2012	4
4/23/2012	3	3052.766	2012	4
4/23/2012	4	3307.565	2012	4
4/23/2012	5	3758.654	2012	4
4/23/2012	6	4022.858	2012	4
4/23/2012	7	4068.566	2012	4
4/23/2012	8	4059.366	2012	4
4/23/2012	9	4012.866	2012	4
4/23/2012	10	3962.466	2012	4
4/23/2012	11	3909.267	2012	4
4/23/2012	12	3912.966	2012	4
4/23/2012	13	3857.666	2012	4
4/23/2012	14	3752.661	2012	4
4/23/2012	15	3661.354	2012	4
4/23/2012	16	3659.466	2012	4
4/23/2012	17	3624.567	2012	4
4/23/2012	18	3659.366	2012	4
4/23/2012	19	3799.567	2012	4
4/23/2012	20	3814.766	2012	4
4/23/2012	21	3592.066	2012	4
4/23/2012	22	3400.266	2012	4
4/23/2012	23	3266.766	2012	4
4/24/2012	0	3183.953	2012	4
4/24/2012	1	3168.959	2012	4
4/24/2012	2	3129.866	2012	4
4/24/2012	3	3178.165	2012	4
4/24/2012	4	3382.964	2012	4
4/24/2012	5	3832.765	2012	4

Day	Hr	Total	Year	Month
4/24/2012	6	4029.765	2012	4
4/24/2012	7	4012.964	2012	4
4/24/2012	8	3939.709	2012	4
4/24/2012	9	3863.766	2012	4
4/24/2012	10	3801.766	2012	4
4/24/2012	11	3785.567	2012	4
4/24/2012	12	3746.366	2012	4
4/24/2012	13	3705.069	2012	4
4/24/2012	14	3705.772	2012	4
4/24/2012	15	3713.767	2012	4
4/24/2012	16	3565.271	2012	4
4/24/2012	17	3646.271	2012	4
4/24/2012	18	3643.266	2012	4
4/24/2012	19	3775.567	2012	4
4/24/2012	20	3761.569	2012	4
4/24/2012	21	3526.563	2012	4
4/24/2012	22	3295.066	2012	4
4/24/2012	23	3113.466	2012	4
4/25/2012	0	2964.866	2012	4
4/25/2012	1	2925.266	2012	4
4/25/2012	2	2858.267	2012	4
4/25/2012	3	2903.165	2012	4
4/25/2012	4	3071.566	2012	4
4/25/2012	5	3470.658	2012	4
4/25/2012	6	3677.855	2012	4
4/25/2012	7	3718.667	2012	4
4/25/2012	8	3751.571	2012	4
4/25/2012	9	3775.073	2012	4
4/25/2012	10	3752.073	2012	4
4/25/2012	11	3805.572	2012	4
4/25/2012	12	3838.174	2012	4
4/25/2012	13	3862.58	2012	4
4/25/2012	14	3855.179	2012	4
4/25/2012	15	3860.374	2012	4
4/25/2012	16	3813.173	2012	4
4/25/2012	17	3806.877	2012	4
4/25/2012	18	3772.875	2012	4
4/25/2012	19	3890.073	2012	4
4/25/2012	20	3847.773	2012	4
4/25/2012	21	3628.572	2012	4
4/25/2012	22	3380.773	2012	4
4/25/2012	23	3163.461	2012	4
4/26/2012	0	2976.663	2012	4
4/26/2012	1	2930.671	2012	4
4/26/2012	2	2852.97	2012	4
4/26/2012	3	2853.167	2012	4
4/26/2012	4	3048.969	2012	4
4/26/2012	5	3327.369	2012	4
4/26/2012	6	3551.369	2012	4
4/26/2012	7	3683.972	2012	4
4/26/2012	8	3832.453	2012	4
4/26/2012	9	3988.373	2012	4
4/26/2012	10	4120.377	2012	4
4/26/2012	11	4111.18	2012	4
4/26/2012	12	4241.681	2012	4
4/26/2012	13	4281.381	2012	4
4/26/2012	14	4320.381	2012	4
4/26/2012	15	4339.28	2012	4
4/26/2012	16	4323.281	2012	4
4/26/2012	17	4238.679	2012	4
4/26/2012	18	4109.474	2012	4
4/26/2012	19	4091.773	2012	4
4/26/2012	20	4009.166	2012	4
4/26/2012	21	3670.55	2012	4

Day	Hr	Total	Year	Month
4/26/2012	22	3346.166	2012	4
4/26/2012	23	3044.067	2012	4
4/27/2012	0	2894.466	2012	4
4/27/2012	1	2778.067	2012	4
4/27/2012	2	2690.667	2012	4
4/27/2012	3	2695.767	2012	4
4/27/2012	4	2857.159	2012	4
4/27/2012	5	3256.458	2012	4
4/27/2012	6	3466.513	2012	4
4/27/2012	7	3544.468	2012	4
4/27/2012	8	3623.167	2012	4
4/27/2012	9	3674.567	2012	4
4/27/2012	10	3656.167	2012	4
4/27/2012	11	3654.267	2012	4
4/27/2012	12	3608.767	2012	4
4/27/2012	13	3601.367	2012	4
4/27/2012	14	3583.067	2012	4
4/27/2012	15	3552.663	2012	4
4/27/2012	16	3494.553	2012	4
4/27/2012	17	3448.867	2012	4
4/27/2012	18	3371.468	2012	4
4/27/2012	19	3481.867	2012	4
4/27/2012	20	3506.531	2012	4
4/27/2012	21	3291.767	2012	4
4/27/2012	22	3064.167	2012	4
4/27/2012	23	2880.467	2012	4
4/28/2012	0	2749.167	2012	4
4/28/2012	1	2641.662	2012	4
4/28/2012	2	2588.352	2012	4
4/28/2012	3	2563.967	2012	4
4/28/2012	4	2649.666	2012	4
4/28/2012	5	2745.167	2012	4
4/28/2012	6	2813.867	2012	4
4/28/2012	7	2973.867	2012	4
4/28/2012	8	3079.167	2012	4
4/28/2012	9	3169.867	2012	4
4/28/2012	10	3175.467	2012	4
4/28/2012	11	3170.972	2012	4
4/28/2012	12	3233.874	2012	4
4/28/2012	13	3293.18	2012	4
4/28/2012	14	3360.963	2012	4
4/28/2012	15	3433.775	2012	4
4/28/2012	16	3459.179	2012	4
4/28/2012	17	3454.979	2012	4
4/28/2012	18	3470.973	2012	4
4/28/2012	19	3402.971	2012	4
4/28/2012	20	3327.367	2012	4
4/28/2012	21	3107.767	2012	4
4/28/2012	22	2873.767	2012	4
4/28/2012	23	2686.366	2012	4
4/29/2012	0	2542.366	2012	4
4/29/2012	1	2429.766	2012	4
4/29/2012	2	2389.656	2012	4
4/29/2012	3	2380.756	2012	4
4/29/2012	4	2397.366	2012	4
4/29/2012	5	2446.366	2012	4
4/29/2012	6	2487.195	2012	4
4/29/2012	7	2672.767	2012	4
4/29/2012	8	2836.566	2012	4
4/29/2012	9	2936.967	2012	4
4/29/2012	10	3029.572	2012	4
4/29/2012	11	3139.973	2012	4
4/29/2012	12	3246.973	2012	4
4/29/2012	13	3352.873	2012	4

Day	Hr	Total	Year	Month
4/29/2012	14	3441.979	2012	4
4/29/2012	15	3549.778	2012	4
4/29/2012	16	3625.976	2012	4
4/29/2012	17	3648.563	2012	4
4/29/2012	18	3604.376	2012	4
4/29/2012	19	3655.173	2012	4
4/29/2012	20	3684.973	2012	4
4/29/2012	21	3440.872	2012	4
4/29/2012	22	3136.273	2012	4
4/29/2012	23	2911.571	2012	4
4/30/2012	0	2750.572	2012	4
4/30/2012	1	2680.172	2012	4
4/30/2012	2	2617.671	2012	4
4/30/2012	3	2674.471	2012	4
4/30/2012	4	2848.071	2012	4
4/30/2012	5	3212.771	2012	4
4/30/2012	6	3432.17	2012	4
4/30/2012	7	3608.172	2012	4
4/30/2012	8	3776.773	2012	4
4/30/2012	9	4011.778	2012	4
4/30/2012	10	4246.28	2012	4
4/30/2012	11	4444.579	2012	4
4/30/2012	12	4579.769	2012	4
4/30/2012	13	4674.171	2012	4
4/30/2012	14	4755.716	2012	4
4/30/2012	15	4731.379	2012	4
4/30/2012	16	4717.68	2012	4
4/30/2012	17	4586.379	2012	4
4/30/2012	18	4454.573	2012	4
4/30/2012	19	4454.273	2012	4
4/30/2012	20	4281.072	2012	4
4/30/2012	21	3983.673	2012	4
4/30/2012	22	3698.372	2012	4
4/30/2012	23	3397.872	2012	4
5/1/2012	0	3222.472	2012	5
5/1/2012	1	3080.372	2012	5
5/1/2012	2	2980.872	2012	5
5/1/2012	3	2939.673	2012	5
5/1/2012	4	3127.972	2012	5
5/1/2012	5	3443.672	2012	5
5/1/2012	6	3692.672	2012	5
5/1/2012	7	3855.472	2012	5
5/1/2012	8	3970.872	2012	5
5/1/2012	9	4089.073	2012	5
5/1/2012	10	4266.674	2012	5
5/1/2012	11	4434.455	2012	5
5/1/2012	12	4609.874	2012	5
5/1/2012	13	4748.062	2012	5
5/1/2012	14	4839.051	2012	5
5/1/2012	15	4803.662	2012	5
5/1/2012	16	4746.963	2012	5
5/1/2012	17	4674.663	2012	5
5/1/2012	18	4568.66	2012	5
5/1/2012	19	4515.26	2012	5
5/1/2012	20	4537.96	2012	5
5/1/2012	21	4220.96	2012	5
5/1/2012	22	3858.86	2012	5
5/1/2012	23	3601.159	2012	5
5/2/2012	0	3388.06	2012	5
5/2/2012	1	3244.959	2012	5
5/2/2012	2	3104.058	2012	5
5/2/2012	3	3085.16	2012	5
5/2/2012	4	3203.552	2012	5
5/2/2012	5	3582.862	2012	5

Day	Hr	Total	Year	Month
5/2/2012	6	3834.354	2012	5
5/2/2012	7	4104.655	2012	5
5/2/2012	8	4326.47	2012	5
5/2/2012	9	4627.38	2012	5
5/2/2012	10	4838.381	2012	5
5/2/2012	11	5063.881	2012	5
5/2/2012	12	5213.681	2012	5
5/2/2012	13	5345.281	2012	5
5/2/2012	14	5416.481	2012	5
5/2/2012	15	5489.577	2012	5
5/2/2012	16	5514.372	2012	5
5/2/2012	17	5409.473	2012	5
5/2/2012	18	5256.172	2012	5
5/2/2012	19	5202.276	2012	5
5/2/2012	20	5111.181	2012	5
5/2/2012	21	4676.38	2012	5
5/2/2012	22	4297.88	2012	5
5/2/2012	23	3883.679	2012	5
5/3/2012	0	3623.679	2012	5
5/3/2012	1	3431.278	2012	5
5/3/2012	2	3299.878	2012	5
5/3/2012	3	3252.078	2012	5
5/3/2012	4	3367.373	2012	5
5/3/2012	5	3686.073	2012	5
5/3/2012	6	3866.876	2012	5
5/3/2012	7	4125.679	2012	5
5/3/2012	8	4330.979	2012	5
5/3/2012	9	4519.38	2012	5
5/3/2012	10	4721.981	2012	5
5/3/2012	11	4868.481	2012	5
5/3/2012	12	5033.08	2012	5
5/3/2012	13	5120.081	2012	5
5/3/2012	14	5171.681	2012	5
5/3/2012	15	5164.781	2012	5
5/3/2012	16	5039.38	2012	5
5/3/2012	17	4897.18	2012	5
5/3/2012	18	4756.18	2012	5
5/3/2012	19	4748.979	2012	5
5/3/2012	20	4676.574	2012	5
5/3/2012	21	4364.879	2012	5
5/3/2012	22	3999.976	2012	5
5/3/2012	23	3681.975	2012	5
5/4/2012	0	3441.973	2012	5
5/4/2012	1	3309.272	2012	5
5/4/2012	2	3148.073	2012	5
5/4/2012	3	3157.573	2012	5
5/4/2012	4	3258.472	2012	5
5/4/2012	5	3522.573	2012	5
5/4/2012	6	3782.573	2012	5
5/4/2012	7	3972.779	2012	5
5/4/2012	8	4225.579	2012	5
5/4/2012	9	4445.08	2012	5
5/4/2012	10	4608.48	2012	5
5/4/2012	11	4821.981	2012	5
5/4/2012	12	4986.115	2012	5
5/4/2012	13	5104.381	2012	5
5/4/2012	14	5217.181	2012	5
5/4/2012	15	5216.481	2012	5
5/4/2012	16	5039.379	2012	5
5/4/2012	17	4800.478	2012	5
5/4/2012	18	4543.376	2012	5
5/4/2012	19	4491.838	2012	5
5/4/2012	20	4405.877	2012	5
5/4/2012	21	4135.574	2012	5

Day	Hr	Total	Year	Month
5/4/2012	22	3851.773	2012	5
5/4/2012	23	3558.872	2012	5
5/5/2012	0	3300.373	2012	5
5/5/2012	1	3079.372	2012	5
5/5/2012	2	3017.972	2012	5
5/5/2012	3	2890.356	2012	5
5/5/2012	4	2886.364	2012	5
5/5/2012	5	2970.071	2012	5
5/5/2012	6	3006.472	2012	5
5/5/2012	7	3188.073	2012	5
5/5/2012	8	3444.373	2012	5
5/5/2012	9	3607.679	2012	5
5/5/2012	10	3798.681	2012	5
5/5/2012	11	3921.88	2012	5
5/5/2012	12	3994.982	2012	5
5/5/2012	13	4150.68	2012	5
5/5/2012	14	4268.281	2012	5
5/5/2012	15	4365.581	2012	5
5/5/2012	16	4397.081	2012	5
5/5/2012	17	4368.982	2012	5
5/5/2012	18	4223.18	2012	5
5/5/2012	19	4184.781	2012	5
5/5/2012	20	4146.68	2012	5
5/5/2012	21	3917.778	2012	5
5/5/2012	22	3596.579	2012	5
5/5/2012	23	3311.478	2012	5
5/6/2012	0	3071.674	2012	5
5/6/2012	1	2896.873	2012	5
5/6/2012	2	2795.174	2012	5
5/6/2012	3	2726.273	2012	5
5/6/2012	4	2741.973	2012	5
5/6/2012	5	2771.073	2012	5
5/6/2012	6	2806.274	2012	5
5/6/2012	7	3014.475	2012	5
5/6/2012	8	3346.081	2012	5
5/6/2012	9	3597.881	2012	5
5/6/2012	10	3928.681	2012	5
5/6/2012	11	4196.182	2012	5
5/6/2012	12	4413.881	2012	5
5/6/2012	13	4550.181	2012	5
5/6/2012	14	4688.781	2012	5
5/6/2012	15	4739.282	2012	5
5/6/2012	16	4843.181	2012	5
5/6/2012	17	4793.082	2012	5
5/6/2012	18	4635.881	2012	5
5/6/2012	19	4511.381	2012	5
5/6/2012	20	4499.58	2012	5
5/6/2012	21	4174.879	2012	5
5/6/2012	22	3750.479	2012	5
5/6/2012	23	3424.779	2012	5
5/7/2012	0	3247.076	2012	5
5/7/2012	1	3100.075	2012	5
5/7/2012	2	3026.473	2012	5
5/7/2012	3	3008.174	2012	5
5/7/2012	4	3160.373	2012	5
5/7/2012	5	3519.473	2012	5
5/7/2012	6	3755.274	2012	5
5/7/2012	7	4008.175	2012	5
5/7/2012	8	4187.278	2012	5
5/7/2012	9	4427.378	2012	5
5/7/2012	10	4654.981	2012	5
5/7/2012	11	4882.981	2012	5
5/7/2012	12	5073.781	2012	5
5/7/2012	13	5193.381	2012	5

Case No. 2018-00295
Attachment 5 to Response to Metro-1 Question No. 37(b)
Page 49 of 823
Bellar

Day	Hr	Total	Year	Month
5/7/2012	14	5329.382	2012	5
5/7/2012	15	5384.881	2012	5
5/7/2012	16	5343.581	2012	5
5/7/2012	17	5222.581	2012	5
5/7/2012	18	5017.58	2012	5
5/7/2012	19	4960.78	2012	5
5/7/2012	20	4696.078	2012	5
5/7/2012	21	4339.777	2012	5
5/7/2012	22	3987.601	2012	5
5/7/2012	23	3615.273	2012	5
5/8/2012	0	3400.972	2012	5
5/8/2012	1	3216.973	2012	5
5/8/2012	2	3202.469	2012	5
5/8/2012	3	3147.255	2012	5
5/8/2012	4	3301.671	2012	5
5/8/2012	5	3624.072	2012	5
5/8/2012	6	3828.373	2012	5
5/8/2012	7	3943.872	2012	5
5/8/2012	8	4053.673	2012	5
5/8/2012	9	4164.478	2012	5
5/8/2012	10	4278.179	2012	5
5/8/2012	11	4374.68	2012	5
5/8/2012	12	4429.88	2012	5
5/8/2012	13	4520.58	2012	5
5/8/2012	14	4605.081	2012	5
5/8/2012	15	4624.781	2012	5
5/8/2012	16	4626.98	2012	5
5/8/2012	17	4506.48	2012	5
5/8/2012	18	4387.578	2012	5
5/8/2012	19	4313.877	2012	5
5/8/2012	20	4240.072	2012	5
5/8/2012	21	3957.509	2012	5
5/8/2012	22	3593.372	2012	5
5/8/2012	23	3304.272	2012	5
5/9/2012	0	3151.472	2012	5
5/9/2012	1	2998.172	2012	5
5/9/2012	2	2908.57	2012	5
5/9/2012	3	2876.071	2012	5
5/9/2012	4	3051.07	2012	5
5/9/2012	5	3388.571	2012	5
5/9/2012	6	3593.271	2012	5
5/9/2012	7	3747.072	2012	5
5/9/2012	8	3771.447	2012	5
5/9/2012	9	3945.879	2012	5
5/9/2012	10	4057.982	2012	5
5/9/2012	11	4105.48	2012	5
5/9/2012	12	4226.479	2012	5
5/9/2012	13	4192.977	2012	5
5/9/2012	14	4191.562	2012	5
5/9/2012	15	4147.076	2012	5
5/9/2012	16	4151.379	2012	5
5/9/2012	17	4083.975	2012	5
5/9/2012	18	3947.773	2012	5
5/9/2012	19	3942.173	2012	5
5/9/2012	20	3943.772	2012	5
5/9/2012	21	3675.871	2012	5
5/9/2012	22	3363.469	2012	5
5/9/2012	23	3146.569	2012	5
5/10/2012	0	2963.466	2012	5
5/10/2012	1	2817.466	2012	5
5/10/2012	2	2762.066	2012	5
5/10/2012	3	2765.266	2012	5
5/10/2012	4	2940.766	2012	5
5/10/2012	5	3223.266	2012	5

Day	Hr	Total	Year	Month
5/10/2012	6	3456.05	2012	5
5/10/2012	7	3562.863	2012	5
5/10/2012	8	3728.871	2012	5
5/10/2012	9	3779.072	2012	5
5/10/2012	10	3867.05	2012	5
5/10/2012	11	3907.373	2012	5
5/10/2012	12	3922.472	2012	5
5/10/2012	13	3947.473	2012	5
5/10/2012	14	3933.274	2012	5
5/10/2012	15	3907.973	2012	5
5/10/2012	16	3882.173	2012	5
5/10/2012	17	3892.874	2012	5
5/10/2012	18	3794.173	2012	5
5/10/2012	19	3756.273	2012	5
5/10/2012	20	3839.672	2012	5
5/10/2012	21	3526.87	2012	5
5/10/2012	22	3305.671	2012	5
5/10/2012	23	3033.768	2012	5
5/11/2012	0	2910.859	2012	5
5/11/2012	1	2827.05	2012	5
5/11/2012	2	2718.466	2012	5
5/11/2012	3	2773.266	2012	5
5/11/2012	4	2890.266	2012	5
5/11/2012	5	3231.967	2012	5
5/11/2012	6	3458.167	2012	5
5/11/2012	7	3584.171	2012	5
5/11/2012	8	3644.572	2012	5
5/11/2012	9	3710.374	2012	5
5/11/2012	10	3742.672	2012	5
5/11/2012	11	3793.98	2012	5
5/11/2012	12	3837.38	2012	5
5/11/2012	13	3945.68	2012	5
5/11/2012	14	3973.879	2012	5
5/11/2012	15	3980.381	2012	5
5/11/2012	16	4013.081	2012	5
5/11/2012	17	3947.88	2012	5
5/11/2012	18	3801.979	2012	5
5/11/2012	19	3749.176	2012	5
5/11/2012	20	3763.973	2012	5
5/11/2012	21	3575.272	2012	5
5/11/2012	22	3291.972	2012	5
5/11/2012	23	3057.268	2012	5
5/12/2012	0	2894.354	2012	5
5/12/2012	1	2755.368	2012	5
5/12/2012	2	2660.37	2012	5
5/12/2012	3	2620.869	2012	5
5/12/2012	4	2694.167	2012	5
5/12/2012	5	2742.771	2012	5
5/12/2012	6	2850.367	2012	5
5/12/2012	7	2972.271	2012	5
5/12/2012	8	3157.872	2012	5
5/12/2012	9	3259.173	2012	5
5/12/2012	10	3259.374	2012	5
5/12/2012	11	3311.579	2012	5
5/12/2012	12	3346.98	2012	5
5/12/2012	13	3320.978	2012	5
5/12/2012	14	3371.579	2012	5
5/12/2012	15	3405.977	2012	5
5/12/2012	16	3343.975	2012	5
5/12/2012	17	3324.674	2012	5
5/12/2012	18	3409.072	2012	5
5/12/2012	19	3394.573	2012	5
5/12/2012	20	3367.373	2012	5
5/12/2012	21	3232.772	2012	5

Day	Hr	Total	Year	Month
5/12/2012	22	3008.472	2012	5
5/12/2012	23	2798.766	2012	5
5/13/2012	0	2671.153	2012	5
5/13/2012	1	2575.17	2012	5
5/13/2012	2	2512.471	2012	5
5/13/2012	3	2516.867	2012	5
5/13/2012	4	2547.371	2012	5
5/13/2012	5	2634.266	2012	5
5/13/2012	6	2646.168	2012	5
5/13/2012	7	2875.367	2012	5
5/13/2012	8	3032.567	2012	5
5/13/2012	9	3122.467	2012	5
5/13/2012	10	3135.067	2012	5
5/13/2012	11	3156.85	2012	5
5/13/2012	12	3083.666	2012	5
5/13/2012	13	3094.467	2012	5
5/13/2012	14	3127.668	2012	5
5/13/2012	15	3093.771	2012	5
5/13/2012	16	3136.271	2012	5
5/13/2012	17	3165.371	2012	5
5/13/2012	18	3186.47	2012	5
5/13/2012	19	3284.872	2012	5
5/13/2012	20	3266.87	2012	5
5/13/2012	21	3127.07	2012	5
5/13/2012	22	2953.071	2012	5
5/13/2012	23	2783.06	2012	5
5/14/2012	0	2692.656	2012	5
5/14/2012	1	2657.569	2012	5
5/14/2012	2	2646.367	2012	5
5/14/2012	3	2715.267	2012	5
5/14/2012	4	2891.367	2012	5
5/14/2012	5	3283.368	2012	5
5/14/2012	6	3535.371	2012	5
5/14/2012	7	3705.468	2012	5
5/14/2012	8	3759.067	2012	5
5/14/2012	9	3860.067	2012	5
5/14/2012	10	3895.271	2012	5
5/14/2012	11	3936.562	2012	5
5/14/2012	12	3970.564	2012	5
5/14/2012	13	3997.773	2012	5
5/14/2012	14	4001.574	2012	5
5/14/2012	15	4010.374	2012	5
5/14/2012	16	4058.573	2012	5
5/14/2012	17	4064.674	2012	5
5/14/2012	18	4026.381	2012	5
5/14/2012	19	4049.973	2012	5
5/14/2012	20	4049.073	2012	5
5/14/2012	21	3805.573	2012	5
5/14/2012	22	3464.373	2012	5
5/14/2012	23	3246.972	2012	5
5/15/2012	0	3071.471	2012	5
5/15/2012	1	2957.171	2012	5
5/15/2012	2	2859.271	2012	5
5/15/2012	3	2871.367	2012	5
5/15/2012	4	3024.758	2012	5
5/15/2012	5	3284.859	2012	5
5/15/2012	6	3550.871	2012	5
5/15/2012	7	3707.787	2012	5
5/15/2012	8	3834.774	2012	5
5/15/2012	9	3924.675	2012	5
5/15/2012	10	4112.881	2012	5
5/15/2012	11	4239.781	2012	5
5/15/2012	12	4375.981	2012	5
5/15/2012	13	4379.581	2012	5

Day	Hr	Total	Year	Month
5/15/2012	14	4431.581	2012	5
5/15/2012	15	4433.581	2012	5
5/15/2012	16	4472.681	2012	5
5/15/2012	17	4424.081	2012	5
5/15/2012	18	4340.981	2012	5
5/15/2012	19	4300.697	2012	5
5/15/2012	20	4297.378	2012	5
5/15/2012	21	3984.974	2012	5
5/15/2012	22	3634.173	2012	5
5/15/2012	23	3351.973	2012	5
5/16/2012	0	3158.372	2012	5
5/16/2012	1	3006.172	2012	5
5/16/2012	2	2877.071	2012	5
5/16/2012	3	2877.07	2012	5
5/16/2012	4	3028.454	2012	5
5/16/2012	5	3341.767	2012	5
5/16/2012	6	3577.672	2012	5
5/16/2012	7	3764.473	2012	5
5/16/2012	8	3922.276	2012	5
5/16/2012	9	4166.181	2012	5
5/16/2012	10	4299.281	2012	5
5/16/2012	11	4396.181	2012	5
5/16/2012	12	4565.881	2012	5
5/16/2012	13	4704.881	2012	5
5/16/2012	14	4826.281	2012	5
5/16/2012	15	4876.481	2012	5
5/16/2012	16	4865.881	2012	5
5/16/2012	17	4776.381	2012	5
5/16/2012	18	4606.581	2012	5
5/16/2012	19	4538.179	2012	5
5/16/2012	20	4506.578	2012	5
5/16/2012	21	4152.673	2012	5
5/16/2012	22	3771.774	2012	5
5/16/2012	23	3503.372	2012	5
5/17/2012	0	3242.473	2012	5
5/17/2012	1	3095.273	2012	5
5/17/2012	2	2967.271	2012	5
5/17/2012	3	2911.771	2012	5
5/17/2012	4	3052.352	2012	5
5/17/2012	5	3366.46	2012	5
5/17/2012	6	3569.167	2012	5
5/17/2012	7	3687.268	2012	5
5/17/2012	8	3848.272	2012	5
5/17/2012	9	3972.674	2012	5
5/17/2012	10	4012.073	2012	5
5/17/2012	11	4154.474	2012	5
5/17/2012	12	4214.511	2012	5
5/17/2012	13	4341.373	2012	5
5/17/2012	14	4422.38	2012	5
5/17/2012	15	4474.98	2012	5
5/17/2012	16	4509.779	2012	5
5/17/2012	17	4429.145	2012	5
5/17/2012	18	4362.391	2012	5
5/17/2012	19	4267.574	2012	5
5/17/2012	20	4215.772	2012	5
5/17/2012	21	3937.273	2012	5
5/17/2012	22	3570.973	2012	5
5/17/2012	23	3317.073	2012	5
5/18/2012	0	3124.672	2012	5
5/18/2012	1	2961.158	2012	5
5/18/2012	2	2845.263	2012	5
5/18/2012	3	2839.167	2012	5
5/18/2012	4	2984.667	2012	5
5/18/2012	5	3249.968	2012	5

Day	Hr	Total	Year	Month
5/18/2012	6	3469.271	2012	5
5/18/2012	7	3613.573	2012	5
5/18/2012	8	3795.073	2012	5
5/18/2012	9	3961.377	2012	5
5/18/2012	10	4104.98	2012	5
5/18/2012	11	4240.08	2012	5
5/18/2012	12	4512.581	2012	5
5/18/2012	13	4611.481	2012	5
5/18/2012	14	4763.481	2012	5
5/18/2012	15	4870.381	2012	5
5/18/2012	16	4880.981	2012	5
5/18/2012	17	4831.081	2012	5
5/18/2012	18	4657.781	2012	5
5/18/2012	19	4508.681	2012	5
5/18/2012	20	4431.179	2012	5
5/18/2012	21	4139.178	2012	5
5/18/2012	22	3776.875	2012	5
5/18/2012	23	3462.784	2012	5
5/19/2012	0	3196.873	2012	5
5/19/2012	1	2972.473	2012	5
5/19/2012	2	2865.873	2012	5
5/19/2012	3	2794.473	2012	5
5/19/2012	4	2793.872	2012	5
5/19/2012	5	2845.269	2012	5
5/19/2012	6	2994.557	2012	5
5/19/2012	7	3227.071	2012	5
5/19/2012	8	3515.978	2012	5
5/19/2012	9	3796.781	2012	5
5/19/2012	10	4017.981	2012	5
5/19/2012	11	4208.281	2012	5
5/19/2012	12	4414.781	2012	5
5/19/2012	13	4579.481	2012	5
5/19/2012	14	4686.982	2012	5
5/19/2012	15	4768.782	2012	5
5/19/2012	16	4833.081	2012	5
5/19/2012	17	4830.482	2012	5
5/19/2012	18	4661.782	2012	5
5/19/2012	19	4460.581	2012	5
5/19/2012	20	4428.281	2012	5
5/19/2012	21	4112.079	2012	5
5/19/2012	22	3714.279	2012	5
5/19/2012	23	3427.678	2012	5
5/20/2012	0	3144.178	2012	5
5/20/2012	1	2993.873	2012	5
5/20/2012	2	2836.973	2012	5
5/20/2012	3	2786.073	2012	5
5/20/2012	4	2787.673	2012	5
5/20/2012	5	2730.373	2012	5
5/20/2012	6	2802.573	2012	5
5/20/2012	7	3025.278	2012	5
5/20/2012	8	3365.681	2012	5
5/20/2012	9	3692.98	2012	5
5/20/2012	10	3907.682	2012	5
5/20/2012	11	4185.381	2012	5
5/20/2012	12	4386.682	2012	5
5/20/2012	13	4516.281	2012	5
5/20/2012	14	4615.582	2012	5
5/20/2012	15	4688.081	2012	5
5/20/2012	16	4738.882	2012	5
5/20/2012	17	4676.781	2012	5
5/20/2012	18	4563.681	2012	5
5/20/2012	19	4454.282	2012	5
5/20/2012	20	4388.479	2012	5
5/20/2012	21	4066.279	2012	5

Day	Hr	Total	Year	Month
5/20/2012	22	3681.379	2012	5
5/20/2012	23	3371.379	2012	5
5/21/2012	0	3165.914	2012	5
5/21/2012	1	3025.476	2012	5
5/21/2012	2	2928.473	2012	5
5/21/2012	3	2977.673	2012	5
5/21/2012	4	3114.073	2012	5
5/21/2012	5	3395.274	2012	5
5/21/2012	6	3642.473	2012	5
5/21/2012	7	3886.977	2012	5
5/21/2012	8	4124.28	2012	5
5/21/2012	9	4370.48	2012	5
5/21/2012	10	4513.58	2012	5
5/21/2012	11	4709.08	2012	5
5/21/2012	12	4781.079	2012	5
5/21/2012	13	4832.181	2012	5
5/21/2012	14	4846.281	2012	5
5/21/2012	15	4809.581	2012	5
5/21/2012	16	4752.681	2012	5
5/21/2012	17	4601.28	2012	5
5/21/2012	18	4439.28	2012	5
5/21/2012	19	4328.874	2012	5
5/21/2012	20	4268.363	2012	5
5/21/2012	21	4008.373	2012	5
5/21/2012	22	3675.563	2012	5
5/21/2012	23	3397.66	2012	5
5/22/2012	0	3188.872	2012	5
5/22/2012	1	3039.172	2012	5
5/22/2012	2	2951.171	2012	5
5/22/2012	3	2883.771	2012	5
5/22/2012	4	3019.971	2012	5
5/22/2012	5	3273.971	2012	5
5/22/2012	6	3481.367	2012	5
5/22/2012	7	3656.868	2012	5
5/22/2012	8	3800.272	2012	5
5/22/2012	9	3936.673	2012	5
5/22/2012	10	4045.575	2012	5
5/22/2012	11	4197.68	2012	5
5/22/2012	12	4426.881	2012	5
5/22/2012	13	4491.48	2012	5
5/22/2012	14	4519.081	2012	5
5/22/2012	15	4513.981	2012	5
5/22/2012	16	4534.981	2012	5
5/22/2012	17	4500.681	2012	5
5/22/2012	18	4384.68	2012	5
5/22/2012	19	4355.379	2012	5
5/22/2012	20	4327.278	2012	5
5/22/2012	21	4074.277	2012	5
5/22/2012	22	3749.173	2012	5
5/22/2012	23	3461.725	2012	5
5/23/2012	0	3251.573	2012	5
5/23/2012	1	3087.773	2012	5
5/23/2012	2	2997.872	2012	5
5/23/2012	3	2981.761	2012	5
5/23/2012	4	3110.06	2012	5
5/23/2012	5	3358.772	2012	5
5/23/2012	6	3612.172	2012	5
5/23/2012	7	3811.672	2012	5
5/23/2012	8	3995.877	2012	5
5/23/2012	9	4217.18	2012	5
5/23/2012	10	4384.281	2012	5
5/23/2012	11	4562.766	2012	5
5/23/2012	12	4757.774	2012	5
5/23/2012	13	4825.257	2012	5

Day	Hr	Total	Year	Month
5/23/2012	14	4932.269	2012	5
5/23/2012	15	4953.371	2012	5
5/23/2012	16	5033.972	2012	5
5/23/2012	17	4926.966	2012	5
5/23/2012	18	4843.259	2012	5
5/23/2012	19	4670.661	2012	5
5/23/2012	20	4600.761	2012	5
5/23/2012	21	4339.361	2012	5
5/23/2012	22	3924.255	2012	5
5/23/2012	23	3624.855	2012	5
5/24/2012	0	3380.754	2012	5
5/24/2012	1	3181.655	2012	5
5/24/2012	2	3085.153	2012	5
5/24/2012	3	3083.753	2012	5
5/24/2012	4	3178.951	2012	5
5/24/2012	5	3443.048	2012	5
5/24/2012	6	3719.648	2012	5
5/24/2012	7	3946.253	2012	5
5/24/2012	8	4204.659	2012	5
5/24/2012	9	4489.359	2012	5
5/24/2012	10	4748.66	2012	5
5/24/2012	11	4951.159	2012	5
5/24/2012	12	5098.26	2012	5
5/24/2012	13	5200.56	2012	5
5/24/2012	14	5332.06	2012	5
5/24/2012	15	5403.06	2012	5
5/24/2012	16	5382.96	2012	5
5/24/2012	17	5326.659	2012	5
5/24/2012	18	5175.46	2012	5
5/24/2012	19	5011.259	2012	5
5/24/2012	20	4834.655	2012	5
5/24/2012	21	4585.256	2012	5
5/24/2012	22	4160.35	2012	5
5/24/2012	23	3859.146	2012	5
5/25/2012	0	3580.446	2012	5
5/25/2012	1	3379.846	2012	5
5/25/2012	2	3229.145	2012	5
5/25/2012	3	3166.746	2012	5
5/25/2012	4	3326.346	2012	5
5/25/2012	5	3551.589	2012	5
5/25/2012	6	3800.847	2012	5
5/25/2012	7	4080.952	2012	5
5/25/2012	8	4411.452	2012	5
5/25/2012	9	4794.653	2012	5
5/25/2012	10	5082.457	2012	5
5/25/2012	11	5359.269	2012	5
5/25/2012	12	5564.277	2012	5
5/25/2012	13	5689.074	2012	5
5/25/2012	14	5727.377	2012	5
5/25/2012	15	5767.078	2012	5
5/25/2012	16	5757.976	2012	5
5/25/2012	17	5612.463	2012	5
5/25/2012	18	5438.555	2012	5
5/25/2012	19	5248.052	2012	5
5/25/2012	20	5107.162	2012	5
5/25/2012	21	4816.548	2012	5
5/25/2012	22	4398.645	2012	5
5/25/2012	23	3937.844	2012	5
5/26/2012	0	3634.745	2012	5
5/26/2012	1	3409.445	2012	5
5/26/2012	2	3203.245	2012	5
5/26/2012	3	3137.644	2012	5
5/26/2012	4	3137.445	2012	5
5/26/2012	5	3126.145	2012	5

Day	Hr	Total	Year	Month
5/26/2012	6	3234.732	2012	5
5/26/2012	7	3537.335	2012	5
5/26/2012	8	3925.848	2012	5
5/26/2012	9	4313.752	2012	5
5/26/2012	10	4646.954	2012	5
5/26/2012	11	4849.859	2012	5
5/26/2012	12	5028.158	2012	5
5/26/2012	13	5200.859	2012	5
5/26/2012	14	5310.359	2012	5
5/26/2012	15	5397.458	2012	5
5/26/2012	16	5394.359	2012	5
5/26/2012	17	5361.859	2012	5
5/26/2012	18	5207.658	2012	5
5/26/2012	19	5027.755	2012	5
5/26/2012	20	4895.651	2012	5
5/26/2012	21	4597.851	2012	5
5/26/2012	22	4171.446	2012	5
5/26/2012	23	3842.044	2012	5
5/27/2012	0	3551.845	2012	5
5/27/2012	1	3379.845	2012	5
5/27/2012	2	3186.745	2012	5
5/27/2012	3	3123.844	2012	5
5/27/2012	4	3089.731	2012	5
5/27/2012	5	2973.229	2012	5
5/27/2012	6	3094.529	2012	5
5/27/2012	7	3440.13	2012	5
5/27/2012	8	3805.948	2012	5
5/27/2012	9	4242.452	2012	5
5/27/2012	10	4576.459	2012	5
5/27/2012	11	4800.758	2012	5
5/27/2012	12	5033.359	2012	5
5/27/2012	13	5114.959	2012	5
5/27/2012	14	5265.258	2012	5
5/27/2012	15	5389.858	2012	5
5/27/2012	16	5411.559	2012	5
5/27/2012	17	5363.958	2012	5
5/27/2012	18	5166.559	2012	5
5/27/2012	19	5041.256	2012	5
5/27/2012	20	4902.951	2012	5
5/27/2012	21	4626.851	2012	5
5/27/2012	22	4235.847	2012	5
5/27/2012	23	3889.645	2012	5
5/28/2012	0	3620.445	2012	5
5/28/2012	1	3392.645	2012	5
5/28/2012	2	3237.045	2012	5
5/28/2012	3	3150.941	2012	5
5/28/2012	4	3185.329	2012	5
5/28/2012	5	3160.629	2012	5
5/28/2012	6	3247.931	2012	5
5/28/2012	7	3584.646	2012	5
5/28/2012	8	3979.25	2012	5
5/28/2012	9	4341.451	2012	5
5/28/2012	10	4700.456	2012	5
5/28/2012	11	4986.759	2012	5
5/28/2012	12	5174.159	2012	5
5/28/2012	13	5270.558	2012	5
5/28/2012	14	5370.059	2012	5
5/28/2012	15	5428.958	2012	5
5/28/2012	16	5464.059	2012	5
5/28/2012	17	5389.458	2012	5
5/28/2012	18	5291.659	2012	5
5/28/2012	19	5156.858	2012	5
5/28/2012	20	5105.951	2012	5
5/28/2012	21	4826.651	2012	5

Day	Hr	Total	Year	Month
5/28/2012	22	4408.05	2012	5
5/28/2012	23	4107.249	2012	5
5/29/2012	0	3784.445	2012	5
5/29/2012	1	3625.545	2012	5
5/29/2012	2	3525.445	2012	5
5/29/2012	3	3519.544	2012	5
5/29/2012	4	3656.645	2012	5
5/29/2012	5	3926.845	2012	5
5/29/2012	6	4146.431	2012	5
5/29/2012	7	4368.729	2012	5
5/29/2012	8	4479.792	2012	5
5/29/2012	9	4643.129	2012	5
5/29/2012	10	4614.029	2012	5
5/29/2012	11	4656.229	2012	5
5/29/2012	12	4713.428	2012	5
5/29/2012	13	4700.329	2012	5
5/29/2012	14	4744.829	2012	5
5/29/2012	15	4857.738	2012	5
5/29/2012	16	4928.851	2012	5
5/29/2012	17	4898.151	2012	5
5/29/2012	18	4817.55	2012	5
5/29/2012	19	4693.848	2012	5
5/29/2012	20	4625.845	2012	5
5/29/2012	21	4363.444	2012	5
5/29/2012	22	3993.843	2012	5
5/29/2012	23	3658.444	2012	5
5/30/2012	0	3380.433	2012	5
5/30/2012	1	3229.129	2012	5
5/30/2012	2	3089.732	2012	5
5/30/2012	3	3063.446	2012	5
5/30/2012	4	3162.342	2012	5
5/30/2012	5	3370.23	2012	5
5/30/2012	6	3642.332	2012	5
5/30/2012	7	3933.744	2012	5
5/30/2012	8	4213.834	2012	5
5/30/2012	9	4532.728	2012	5
5/30/2012	10	4737.665	2012	5
5/30/2012	11	4978.06	2012	5
5/30/2012	12	5057.86	2012	5
5/30/2012	13	5045.258	2012	5
5/30/2012	14	4954.758	2012	5
5/30/2012	15	4899.26	2012	5
5/30/2012	16	4873.907	2012	5
5/30/2012	17	4811.459	2012	5
5/30/2012	18	4687.558	2012	5
5/30/2012	19	4484.949	2012	5
5/30/2012	20	4400.747	2012	5
5/30/2012	21	4110.145	2012	5
5/30/2012	22	3748.847	2012	5
5/30/2012	23	3435.747	2012	5
5/31/2012	0	3175.147	2012	5
5/31/2012	1	3039.947	2012	5
5/31/2012	2	2920.647	2012	5
5/31/2012	3	2874.848	2012	5
5/31/2012	4	2981.747	2012	5
5/31/2012	5	3202.848	2012	5
5/31/2012	6	3439.048	2012	5
5/31/2012	7	3696.848	2012	5
5/31/2012	8	3931.447	2012	5
5/31/2012	9	4136.347	2012	5
5/31/2012	10	4398.946	2012	5
5/31/2012	11	4598.946	2012	5
5/31/2012	12	4761.446	2012	5
5/31/2012	13	4916.548	2012	5

Day	Hr	Total	Year	Month
5/31/2012	14	5070.751	2012	5
5/31/2012	15	5176.454	2012	5
5/31/2012	16	5181.058	2012	5
5/31/2012	17	5073.653	2012	5
5/31/2012	18	4823.745	2012	5
5/31/2012	19	4652.946	2012	5
5/31/2012	20	4509.34	2012	5
5/31/2012	21	4218.83	2012	5
5/31/2012	22	3883.33	2012	5
5/31/2012	23	3622.53	2012	5
6/1/2012	0	3377.53	2012	6
6/1/2012	1	3271.13	2012	6
6/1/2012	2	3157.03	2012	6
6/1/2012	3	3155.13	2012	6
6/1/2012	4	3220.23	2012	6
6/1/2012	5	3472.831	2012	6
6/1/2012	6	3639.643	2012	6
6/1/2012	7	3771.447	2012	6
6/1/2012	8	3843.036	2012	6
6/1/2012	9	3922.74	2012	6
6/1/2012	10	3961.954	2012	6
6/1/2012	11	3914.166	2012	6
6/1/2012	12	3895.466	2012	6
6/1/2012	13	3798.066	2012	6
6/1/2012	14	3748.965	2012	6
6/1/2012	15	3667.266	2012	6
6/1/2012	16	3613.358	2012	6
6/1/2012	17	3527.05	2012	6
6/1/2012	18	3441.866	2012	6
6/1/2012	19	3483.865	2012	6
6/1/2012	20	3565.066	2012	6
6/1/2012	21	3406.565	2012	6
6/1/2012	22	3233.065	2012	6
6/1/2012	23	3004.666	2012	6
6/2/2012	0	2848.262	2012	6
6/2/2012	1	2756.252	2012	6
6/2/2012	2	2653.266	2012	6
6/2/2012	3	2629.965	2012	6
6/2/2012	4	2641.965	2012	6
6/2/2012	5	2664.665	2012	6
6/2/2012	6	2753.566	2012	6
6/2/2012	7	2919.567	2012	6
6/2/2012	8	3066.265	2012	6
6/2/2012	9	3175.566	2012	6
6/2/2012	10	3264.854	2012	6
6/2/2012	11	3249.456	2012	6
6/2/2012	12	3261.764	2012	6
6/2/2012	13	3233.965	2012	6
6/2/2012	14	3261.265	2012	6
6/2/2012	15	3301.064	2012	6
6/2/2012	16	3309.065	2012	6
6/2/2012	17	3259.464	2012	6
6/2/2012	18	3210.165	2012	6
6/2/2012	19	3234.464	2012	6
6/2/2012	20	3320.465	2012	6
6/2/2012	21	3186.352	2012	6
6/2/2012	22	3027.957	2012	6
6/2/2012	23	2810.566	2012	6
6/3/2012	0	2676.065	2012	6
6/3/2012	1	2520.565	2012	6
6/3/2012	2	2527.755	2012	6
6/3/2012	3	2484.457	2012	6
6/3/2012	4	2534.166	2012	6
6/3/2012	5	2504.866	2012	6

Day	Hr	Total	Year	Month
6/3/2012	6	2601.165	2012	6
6/3/2012	7	2749.965	2012	6
6/3/2012	8	2955.465	2012	6
6/3/2012	9	3212.765	2012	6
6/3/2012	10	3369.264	2012	6
6/3/2012	11	3584.07	2012	6
6/3/2012	12	3680.971	2012	6
6/3/2012	13	3820.872	2012	6
6/3/2012	14	3946.872	2012	6
6/3/2012	15	4074.171	2012	6
6/3/2012	16	4153.772	2012	6
6/3/2012	17	4142.071	2012	6
6/3/2012	18	4106.971	2012	6
6/3/2012	19	3971.068	2012	6
6/3/2012	20	3964.964	2012	6
6/3/2012	21	3755.765	2012	6
6/3/2012	22	3457.652	2012	6
6/3/2012	23	3204.151	2012	6
6/4/2012	0	3084.165	2012	6
6/4/2012	1	2943.665	2012	6
6/4/2012	2	2897.965	2012	6
6/4/2012	3	2927.652	2012	6
6/4/2012	4	3071.359	2012	6
6/4/2012	5	3256.166	2012	6
6/4/2012	6	3514.866	2012	6
6/4/2012	7	3771.966	2012	6
6/4/2012	8	3980.565	2012	6
6/4/2012	9	4187.165	2012	6
6/4/2012	10	4373.165	2012	6
6/4/2012	11	4407.165	2012	6
6/4/2012	12	4415.465	2012	6
6/4/2012	13	4364.165	2012	6
6/4/2012	14	4286.449	2012	6
6/4/2012	15	4194.557	2012	6
6/4/2012	16	4096.966	2012	6
6/4/2012	17	4027.566	2012	6
6/4/2012	18	3960.851	2012	6
6/4/2012	19	3949.164	2012	6
6/4/2012	20	3951.165	2012	6
6/4/2012	21	3720.666	2012	6
6/4/2012	22	3468.659	2012	6
6/4/2012	23	3244.953	2012	6
6/5/2012	0	3070.665	2012	6
6/5/2012	1	2986.866	2012	6
6/5/2012	2	2902.165	2012	6
6/5/2012	3	2856.956	2012	6
6/5/2012	4	3005.159	2012	6
6/5/2012	5	3217.065	2012	6
6/5/2012	6	3461.466	2012	6
6/5/2012	7	3700.066	2012	6
6/5/2012	8	3873.965	2012	6
6/5/2012	9	4009.165	2012	6
6/5/2012	10	4118.965	2012	6
6/5/2012	11	4238.662	2012	6
6/5/2012	12	4346.47	2012	6
6/5/2012	13	4436.457	2012	6
6/5/2012	14	4471.46	2012	6
6/5/2012	15	4455.359	2012	6
6/5/2012	16	4396.359	2012	6
6/5/2012	17	4312.781	2012	6
6/5/2012	18	4171.053	2012	6
6/5/2012	19	4127.049	2012	6
6/5/2012	20	4087.046	2012	6
6/5/2012	21	3883.845	2012	6

Day	Hr	Total	Year	Month
6/5/2012	22	3555.247	2012	6
6/5/2012	23	3335.747	2012	6
6/6/2012	0	3123.447	2012	6
6/6/2012	1	3004.947	2012	6
6/6/2012	2	2901.046	2012	6
6/6/2012	3	2863.447	2012	6
6/6/2012	4	2988.746	2012	6
6/6/2012	5	3148.348	2012	6
6/6/2012	6	3408.247	2012	6
6/6/2012	7	3593.247	2012	6
6/6/2012	8	3783.647	2012	6
6/6/2012	9	3906.347	2012	6
6/6/2012	10	3985.546	2012	6
6/6/2012	11	4090.645	2012	6
6/6/2012	12	4216.347	2012	6
6/6/2012	13	4241.846	2012	6
6/6/2012	14	4293.946	2012	6
6/6/2012	15	4308.646	2012	6
6/6/2012	16	4340.847	2012	6
6/6/2012	17	4315.946	2012	6
6/6/2012	18	4226.546	2012	6
6/6/2012	19	4140.647	2012	6
6/6/2012	20	4099.045	2012	6
6/6/2012	21	3912.547	2012	6
6/6/2012	22	3583.347	2012	6
6/6/2012	23	3297.747	2012	6
6/7/2012	0	3119.546	2012	6
6/7/2012	1	2974.347	2012	6
6/7/2012	2	2910.847	2012	6
6/7/2012	3	2844.246	2012	6
6/7/2012	4	3020.147	2012	6
6/7/2012	5	3217.047	2012	6
6/7/2012	6	3425.447	2012	6
6/7/2012	7	3657.247	2012	6
6/7/2012	8	3809.747	2012	6
6/7/2012	9	4028.747	2012	6
6/7/2012	10	4158.746	2012	6
6/7/2012	11	4435.546	2012	6
6/7/2012	12	4532.149	2012	6
6/7/2012	13	4624.069	2012	6
6/7/2012	14	4739.972	2012	6
6/7/2012	15	4811.516	2012	6
6/7/2012	16	4841.472	2012	6
6/7/2012	17	4778.871	2012	6
6/7/2012	18	4693.369	2012	6
6/7/2012	19	4514.265	2012	6
6/7/2012	20	4417.864	2012	6
6/7/2012	21	4167.765	2012	6
6/7/2012	22	3813.265	2012	6
6/7/2012	23	3486.565	2012	6
6/8/2012	0	3218.266	2012	6
6/8/2012	1	3027.265	2012	6
6/8/2012	2	2991.966	2012	6
6/8/2012	3	2894.653	2012	6
6/8/2012	4	3093.252	2012	6
6/8/2012	5	3203.066	2012	6
6/8/2012	6	3450.266	2012	6
6/8/2012	7	3738.366	2012	6
6/8/2012	8	3946.265	2012	6
6/8/2012	9	4231.065	2012	6
6/8/2012	10	4439.871	2012	6
6/8/2012	11	4630.089	2012	6
6/8/2012	12	4828.272	2012	6
6/8/2012	13	4931.672	2012	6

Day	Hr	Total	Year	Month
6/8/2012	14	5062.075	2012	6
6/8/2012	15	5130.979	2012	6
6/8/2012	16	5144.478	2012	6
6/8/2012	17	5107.775	2012	6
6/8/2012	18	4947.672	2012	6
6/8/2012	19	4716.671	2012	6
6/8/2012	20	4616.564	2012	6
6/8/2012	21	4275.665	2012	6
6/8/2012	22	3873.764	2012	6
6/8/2012	23	3561.765	2012	6
6/9/2012	0	3275.159	2012	6
6/9/2012	1	3037.149	2012	6
6/9/2012	2	2927.665	2012	6
6/9/2012	3	2847.366	2012	6
6/9/2012	4	2885.765	2012	6
6/9/2012	5	2892.366	2012	6
6/9/2012	6	3004.537	2012	6
6/9/2012	7	3261.449	2012	6
6/9/2012	8	3558.263	2012	6
6/9/2012	9	3865.464	2012	6
6/9/2012	10	4112.771	2012	6
6/9/2012	11	4368.971	2012	6
6/9/2012	12	4540.974	2012	6
6/9/2012	13	4696.779	2012	6
6/9/2012	14	4826.848	2012	6
6/9/2012	15	4969.579	2012	6
6/9/2012	16	4976.179	2012	6
6/9/2012	17	4983.779	2012	6
6/9/2012	18	4881.076	2012	6
6/9/2012	19	4655.872	2012	6
6/9/2012	20	4520.568	2012	6
6/9/2012	21	4273.165	2012	6
6/9/2012	22	3867.464	2012	6
6/9/2012	23	3512.265	2012	6
6/10/2012	0	3248.464	2012	6
6/10/2012	1	3049.351	2012	6
6/10/2012	2	2937.851	2012	6
6/10/2012	3	2926.065	2012	6
6/10/2012	4	2893.266	2012	6
6/10/2012	5	2811.866	2012	6
6/10/2012	6	2917.966	2012	6
6/10/2012	7	3057.065	2012	6
6/10/2012	8	3434.165	2012	6
6/10/2012	9	3758.765	2012	6
6/10/2012	10	3954.969	2012	6
6/10/2012	11	4169.071	2012	6
6/10/2012	12	4403.072	2012	6
6/10/2012	13	4484.271	2012	6
6/10/2012	14	4606.671	2012	6
6/10/2012	15	4633.671	2012	6
6/10/2012	16	4564.37	2012	6
6/10/2012	17	4480.667	2012	6
6/10/2012	18	4344.065	2012	6
6/10/2012	19	4255.264	2012	6
6/10/2012	20	4267.965	2012	6
6/10/2012	21	4078.064	2012	6
6/10/2012	22	3734.664	2012	6
6/10/2012	23	3451.064	2012	6
6/11/2012	0	3250.248	2012	6
6/11/2012	1	3131.754	2012	6
6/11/2012	2	3084.364	2012	6
6/11/2012	3	3158.064	2012	6
6/11/2012	4	3320.057	2012	6
6/11/2012	5	3596.149	2012	6

Day	Hr	Total	Year	Month
6/11/2012	6	3843.965	2012	6
6/11/2012	7	4078.165	2012	6
6/11/2012	8	4281.465	2012	6
6/11/2012	9	4449.365	2012	6
6/11/2012	10	4584.164	2012	6
6/11/2012	11	4734.668	2012	6
6/11/2012	12	4935.571	2012	6
6/11/2012	13	5061.972	2012	6
6/11/2012	14	5209.671	2012	6
6/11/2012	15	5261.372	2012	6
6/11/2012	16	5282.873	2012	6
6/11/2012	17	5241.671	2012	6
6/11/2012	18	5080.971	2012	6
6/11/2012	19	4984.871	2012	6
6/11/2012	20	4899.065	2012	6
6/11/2012	21	4662.765	2012	6
6/11/2012	22	4280.753	2012	6
6/11/2012	23	3947.247	2012	6
6/12/2012	0	3715.762	2012	6
6/12/2012	1	3503.964	2012	6
6/12/2012	2	3374.85	2012	6
6/12/2012	3	3314.66	2012	6
6/12/2012	4	3434.965	2012	6
6/12/2012	5	3636.265	2012	6
6/12/2012	6	3865.256	2012	6
6/12/2012	7	4142.856	2012	6
6/12/2012	8	4384.365	2012	6
6/12/2012	9	4612.364	2012	6
6/12/2012	10	4904.269	2012	6
6/12/2012	11	5156.872	2012	6
6/12/2012	12	5406.872	2012	6
6/12/2012	13	5512.541	2012	6
6/12/2012	14	5594.873	2012	6
6/12/2012	15	5586.572	2012	6
6/12/2012	16	5538.772	2012	6
6/12/2012	17	5382.071	2012	6
6/12/2012	18	5181.072	2012	6
6/12/2012	19	4964.37	2012	6
6/12/2012	20	4837.565	2012	6
6/12/2012	21	4530.064	2012	6
6/12/2012	22	4139.064	2012	6
6/12/2012	23	3711.265	2012	6
6/13/2012	0	3457.165	2012	6
6/13/2012	1	3288.365	2012	6
6/13/2012	2	3143.064	2012	6
6/13/2012	3	3063.565	2012	6
6/13/2012	4	3128.165	2012	6
6/13/2012	5	3302.566	2012	6
6/13/2012	6	3578.866	2012	6
6/13/2012	7	3774.566	2012	6
6/13/2012	8	3951.865	2012	6
6/13/2012	9	4286.417	2012	6
6/13/2012	10	4509.35	2012	6
6/13/2012	11	4692.859	2012	6
6/13/2012	12	4896.665	2012	6
6/13/2012	13	5016.871	2012	6
6/13/2012	14	5149.772	2012	6
6/13/2012	15	5225.571	2012	6
6/13/2012	16	5288.672	2012	6
6/13/2012	17	5225.271	2012	6
6/13/2012	18	5088.371	2012	6
6/13/2012	19	4865.966	2012	6
6/13/2012	20	4719.964	2012	6
6/13/2012	21	4444.364	2012	6

Day	Hr	Total	Year	Month
6/13/2012	22	4061.265	2012	6
6/13/2012	23	3655.064	2012	6
6/14/2012	0	3451.264	2012	6
6/14/2012	1	3175.265	2012	6
6/14/2012	2	2978.965	2012	6
6/14/2012	3	2934.759	2012	6
6/14/2012	4	3032.351	2012	6
6/14/2012	5	3206.765	2012	6
6/14/2012	6	3458.266	2012	6
6/14/2012	7	3723.266	2012	6
6/14/2012	8	3962.065	2012	6
6/14/2012	9	4282.965	2012	6
6/14/2012	10	4496.764	2012	6
6/14/2012	11	4781.869	2012	6
6/14/2012	12	4949.371	2012	6
6/14/2012	13	5102.972	2012	6
6/14/2012	14	5226.172	2012	6
6/14/2012	15	5336.571	2012	6
6/14/2012	16	5351.572	2012	6
6/14/2012	17	5308.372	2012	6
6/14/2012	18	5149.371	2012	6
6/14/2012	19	4959.67	2012	6
6/14/2012	20	4780.965	2012	6
6/14/2012	21	4470.664	2012	6
6/14/2012	22	4043.964	2012	6
6/14/2012	23	3673.655	2012	6
6/15/2012	0	3391.554	2012	6
6/15/2012	1	3252.466	2012	6
6/15/2012	2	3056.065	2012	6
6/15/2012	3	3042.965	2012	6
6/15/2012	4	3138.266	2012	6
6/15/2012	5	3265.366	2012	6
6/15/2012	6	3566.765	2012	6
6/15/2012	7	3881.466	2012	6
6/15/2012	8	4178.265	2012	6
6/15/2012	9	4492.865	2012	6
6/15/2012	10	4785.671	2012	6
6/15/2012	11	5070.172	2012	6
6/15/2012	12	5333.975	2012	6
6/15/2012	13	5492.379	2012	6
6/15/2012	14	5643.279	2012	6
6/15/2012	15	5743.379	2012	6
6/15/2012	16	5763.779	2012	6
6/15/2012	17	5667.979	2012	6
6/15/2012	18	5519.578	2012	6
6/15/2012	19	5349.573	2012	6
6/15/2012	20	5177.471	2012	6
6/15/2012	21	4905.97	2012	6
6/15/2012	22	4516.066	2012	6
6/15/2012	23	4125.859	2012	6
6/16/2012	0	3791.947	2012	6
6/16/2012	1	3611.355	2012	6
6/16/2012	2	3392.464	2012	6
6/16/2012	3	3306.357	2012	6
6/16/2012	4	3225.953	2012	6
6/16/2012	5	3211.764	2012	6
6/16/2012	6	3308.165	2012	6
6/16/2012	7	3548.365	2012	6
6/16/2012	8	3773.465	2012	6
6/16/2012	9	4035.169	2012	6
6/16/2012	10	4274.071	2012	6
6/16/2012	11	4488.971	2012	6
6/16/2012	12	4620.872	2012	6
6/16/2012	13	4837.172	2012	6

Day	Hr	Total	Year	Month
6/16/2012	14	4955.172	2012	6
6/16/2012	15	5059.894	2012	6
6/16/2012	16	5021.379	2012	6
6/16/2012	17	4918.476	2012	6
6/16/2012	18	4825.79	2012	6
6/16/2012	19	4660.871	2012	6
6/16/2012	20	4610.668	2012	6
6/16/2012	21	4357.164	2012	6
6/16/2012	22	4059.064	2012	6
6/16/2012	23	3656.664	2012	6
6/17/2012	0	3453.265	2012	6
6/17/2012	1	3276.164	2012	6
6/17/2012	2	3108.15	2012	6
6/17/2012	3	3100.254	2012	6
6/17/2012	4	3035.665	2012	6
6/17/2012	5	3071.964	2012	6
6/17/2012	6	3077.065	2012	6
6/17/2012	7	3432.765	2012	6
6/17/2012	8	3741.466	2012	6
6/17/2012	9	3959.569	2012	6
6/17/2012	10	4050.171	2012	6
6/17/2012	11	4200.066	2012	6
6/17/2012	12	4293.759	2012	6
6/17/2012	13	4324.467	2012	6
6/17/2012	14	4339.071	2012	6
6/17/2012	15	4341.871	2012	6
6/17/2012	16	4364.671	2012	6
6/17/2012	17	4350.069	2012	6
6/17/2012	18	4285.871	2012	6
6/17/2012	19	4225.17	2012	6
6/17/2012	20	4311.264	2012	6
6/17/2012	21	4102.264	2012	6
6/17/2012	22	3847.965	2012	6
6/17/2012	23	3500.851	2012	6
6/18/2012	0	3304.651	2012	6
6/18/2012	1	3216.564	2012	6
6/18/2012	2	3168.964	2012	6
6/18/2012	3	3144.065	2012	6
6/18/2012	4	3348.464	2012	6
6/18/2012	5	3546.249	2012	6
6/18/2012	6	3870.66	2012	6
6/18/2012	7	4196.564	2012	6
6/18/2012	8	4570.869	2012	6
6/18/2012	9	4907.672	2012	6
6/18/2012	10	5146.772	2012	6
6/18/2012	11	5463.272	2012	6
6/18/2012	12	5632.972	2012	6
6/18/2012	13	5789.577	2012	6
6/18/2012	14	5862.578	2012	6
6/18/2012	15	5924.679	2012	6
6/18/2012	16	5924.379	2012	6
6/18/2012	17	5835.978	2012	6
6/18/2012	18	5689.479	2012	6
6/18/2012	19	5524.772	2012	6
6/18/2012	20	5375.171	2012	6
6/18/2012	21	5082.27	2012	6
6/18/2012	22	4662.87	2012	6
6/18/2012	23	4240.46	2012	6
6/19/2012	0	3952.865	2012	6
6/19/2012	1	3755.364	2012	6
6/19/2012	2	3526.064	2012	6
6/19/2012	3	3470.254	2012	6
6/19/2012	4	3568.849	2012	6
6/19/2012	5	3716.664	2012	6

Day	Hr	Total	Year	Month
6/19/2012	6	4026.265	2012	6
6/19/2012	7	4402.265	2012	6
6/19/2012	8	4758.372	2012	6
6/19/2012	9	5124.372	2012	6
6/19/2012	10	5369.074	2012	6
6/19/2012	11	5663.378	2012	6
6/19/2012	12	5899.578	2012	6
6/19/2012	13	5986.178	2012	6
6/19/2012	14	6109.579	2012	6
6/19/2012	15	6156.978	2012	6
6/19/2012	16	6124.078	2012	6
6/19/2012	17	6060.378	2012	6
6/19/2012	18	5828.578	2012	6
6/19/2012	19	5695.574	2012	6
6/19/2012	20	5486.171	2012	6
6/19/2012	21	5186.668	2012	6
6/19/2012	22	4772.367	2012	6
6/19/2012	23	4327.363	2012	6
6/20/2012	0	4011.164	2012	6
6/20/2012	1	3785.357	2012	6
6/20/2012	2	3609.546	2012	6
6/20/2012	3	3505.361	2012	6
6/20/2012	4	3572.763	2012	6
6/20/2012	5	3763.064	2012	6
6/20/2012	6	4049.652	2012	6
6/20/2012	7	4434.561	2012	6
6/20/2012	8	4849.368	2012	6
6/20/2012	9	5220.772	2012	6
6/20/2012	10	5565.776	2012	6
6/20/2012	11	5828.878	2012	6
6/20/2012	12	6078.977	2012	6
6/20/2012	13	6191.579	2012	6
6/20/2012	14	6289.878	2012	6
6/20/2012	15	6310.778	2012	6
6/20/2012	16	6288.574	2012	6
6/20/2012	17	6187.369	2012	6
6/20/2012	18	6053.969	2012	6
6/20/2012	19	5818.575	2012	6
6/20/2012	20	5676.07	2012	6
6/20/2012	21	5303.77	2012	6
6/20/2012	22	4872.868	2012	6
6/20/2012	23	4425.063	2012	6
6/21/2012	0	4149.164	2012	6
6/21/2012	1	3876.299	2012	6
6/21/2012	2	3729.964	2012	6
6/21/2012	3	3606.147	2012	6
6/21/2012	4	3730.654	2012	6
6/21/2012	5	3851.164	2012	6
6/21/2012	6	4155.764	2012	6
6/21/2012	7	4558.764	2012	6
6/21/2012	8	4915.171	2012	6
6/21/2012	9	5311.371	2012	6
6/21/2012	10	5568.678	2012	6
6/21/2012	11	5909.278	2012	6
6/21/2012	12	6034.878	2012	6
6/21/2012	13	6158.178	2012	6
6/21/2012	14	6257.74	2012	6
6/21/2012	15	6265.779	2012	6
6/21/2012	16	6272.277	2012	6
6/21/2012	17	6132.07	2012	6
6/21/2012	18	5922.973	2012	6
6/21/2012	19	5778.27	2012	6
6/21/2012	20	5556.57	2012	6
6/21/2012	21	5236.57	2012	6

Day	Hr	Total	Year	Month
6/21/2012	22	4847.765	2012	6
6/21/2012	23	4386.863	2012	6
6/22/2012	0	4092.464	2012	6
6/22/2012	1	3889.063	2012	6
6/22/2012	2	3686.064	2012	6
6/22/2012	3	3622.963	2012	6
6/22/2012	4	3705.358	2012	6
6/22/2012	5	3855.047	2012	6
6/22/2012	6	4125.459	2012	6
6/22/2012	7	4373.664	2012	6
6/22/2012	8	4673.166	2012	6
6/22/2012	9	5035.471	2012	6
6/22/2012	10	5242.271	2012	6
6/22/2012	11	5528.971	2012	6
6/22/2012	12	5685.076	2012	6
6/22/2012	13	5816.078	2012	6
6/22/2012	14	5888.678	2012	6
6/22/2012	15	5900.078	2012	6
6/22/2012	16	5830.678	2012	6
6/22/2012	17	5720.378	2012	6
6/22/2012	18	5549.077	2012	6
6/22/2012	19	5304.871	2012	6
6/22/2012	20	5101.469	2012	6
6/22/2012	21	4837.767	2012	6
6/22/2012	22	4455.764	2012	6
6/22/2012	23	4039.563	2012	6
6/23/2012	0	3759.864	2012	6
6/23/2012	1	3512.663	2012	6
6/23/2012	2	3281.564	2012	6
6/23/2012	3	3207.163	2012	6
6/23/2012	4	3125.664	2012	6
6/23/2012	5	3105.166	2012	6
6/23/2012	6	3221.065	2012	6
6/23/2012	7	3489.564	2012	6
6/23/2012	8	3875.999	2012	6
6/23/2012	9	4225.767	2012	6
6/23/2012	10	4553.371	2012	6
6/23/2012	11	4790.671	2012	6
6/23/2012	12	4946.972	2012	6
6/23/2012	13	5115.178	2012	6
6/23/2012	14	5259.978	2012	6
6/23/2012	15	5340.978	2012	6
6/23/2012	16	5363.978	2012	6
6/23/2012	17	5331.778	2012	6
6/23/2012	18	5244.777	2012	6
6/23/2012	19	4920.271	2012	6
6/23/2012	20	4749.469	2012	6
6/23/2012	21	4499.568	2012	6
6/23/2012	22	4147.464	2012	6
6/23/2012	23	3810.063	2012	6
6/24/2012	0	3569.164	2012	6
6/24/2012	1	3403.364	2012	6
6/24/2012	2	3244.363	2012	6
6/24/2012	3	3200.664	2012	6
6/24/2012	4	3128.447	2012	6
6/24/2012	5	3013.258	2012	6
6/24/2012	6	3097.664	2012	6
6/24/2012	7	3421.864	2012	6
6/24/2012	8	3828.867	2012	6
6/24/2012	9	4264.571	2012	6
6/24/2012	10	4595.574	2012	6
6/24/2012	11	4889.678	2012	6
6/24/2012	12	5122.978	2012	6
6/24/2012	13	5267.179	2012	6

Day	Hr	Total	Year	Month
6/24/2012	14	5440.577	2012	6
6/24/2012	15	5593.079	2012	6
6/24/2012	16	5584.278	2012	6
6/24/2012	17	5504.678	2012	6
6/24/2012	18	5446.378	2012	6
6/24/2012	19	5207.375	2012	6
6/24/2012	20	5095.37	2012	6
6/24/2012	21	4848.069	2012	6
6/24/2012	22	4368.466	2012	6
6/24/2012	23	4016.963	2012	6
6/25/2012	0	3711.564	2012	6
6/25/2012	1	3540.664	2012	6
6/25/2012	2	3406.731	2012	6
6/25/2012	3	3421.563	2012	6
6/25/2012	4	3490.856	2012	6
6/25/2012	5	3706.748	2012	6
6/25/2012	6	3955.364	2012	6
6/25/2012	7	4329.564	2012	6
6/25/2012	8	4662.367	2012	6
6/25/2012	9	5064.271	2012	6
6/25/2012	10	5387.371	2012	6
6/25/2012	11	5702.474	2012	6
6/25/2012	12	5912.777	2012	6
6/25/2012	13	6007.279	2012	6
6/25/2012	14	6032.978	2012	6
6/25/2012	15	6035.078	2012	6
6/25/2012	16	6005.078	2012	6
6/25/2012	17	5836.778	2012	6
6/25/2012	18	5597.274	2012	6
6/25/2012	19	5333.07	2012	6
6/25/2012	20	5091.121	2012	6
6/25/2012	21	4719.364	2012	6
6/25/2012	22	4286.064	2012	6
6/25/2012	23	3839.563	2012	6
6/26/2012	0	3524.864	2012	6
6/26/2012	1	3331.963	2012	6
6/26/2012	2	3160.564	2012	6
6/26/2012	3	3093.663	2012	6
6/26/2012	4	3168.465	2012	6
6/26/2012	5	3284.665	2012	6
6/26/2012	6	3556.565	2012	6
6/26/2012	7	3733.465	2012	6
6/26/2012	8	3958.256	2012	6
6/26/2012	9	4135.951	2012	6
6/26/2012	10	4278.664	2012	6
6/26/2012	11	4451.864	2012	6
6/26/2012	12	4582.864	2012	6
6/26/2012	13	4734.164	2012	6
6/26/2012	14	4850.166	2012	6
6/26/2012	15	4921.371	2012	6
6/26/2012	16	5012.471	2012	6
6/26/2012	17	4939.27	2012	6
6/26/2012	18	4826.968	2012	6
6/26/2012	19	4582.764	2012	6
6/26/2012	20	4468.364	2012	6
6/26/2012	21	4194.064	2012	6
6/26/2012	22	3809.764	2012	6
6/26/2012	23	3472.164	2012	6
6/27/2012	0	3236.663	2012	6
6/27/2012	1	3062.565	2012	6
6/27/2012	2	2954.065	2012	6
6/27/2012	3	2912.952	2012	6
6/27/2012	4	3007.555	2012	6
6/27/2012	5	3194.365	2012	6

Day	Hr	Total	Year	Month
6/27/2012	6	3429.166	2012	6
6/27/2012	7	3690.165	2012	6
6/27/2012	8	3939.164	2012	6
6/27/2012	9	4226.965	2012	6
6/27/2012	10	4465.664	2012	6
6/27/2012	11	4742.07	2012	6
6/27/2012	12	4951.871	2012	6
6/27/2012	13	5187.873	2012	6
6/27/2012	14	5388.578	2012	6
6/27/2012	15	5540.478	2012	6
6/27/2012	16	5631.278	2012	6
6/27/2012	17	5637.278	2012	6
6/27/2012	18	5486.978	2012	6
6/27/2012	19	5262.371	2012	6
6/27/2012	20	5018.27	2012	6
6/27/2012	21	4698.864	2012	6
6/27/2012	22	4267.763	2012	6
6/27/2012	23	3893.064	2012	6
6/28/2012	0	3612.274	2012	6
6/28/2012	1	3399.555	2012	6
6/28/2012	2	3243.547	2012	6
6/28/2012	3	3156.564	2012	6
6/28/2012	4	3269.265	2012	6
6/28/2012	5	3413.166	2012	6
6/28/2012	6	3652.565	2012	6
6/28/2012	7	3979.964	2012	6
6/28/2012	8	4349.567	2012	6
6/28/2012	9	4731.371	2012	6
6/28/2012	10	5111.876	2012	6
6/28/2012	11	5506.478	2012	6
6/28/2012	12	5885.779	2012	6
6/28/2012	13	6173.279	2012	6
6/28/2012	14	6373.575	2012	6
6/28/2012	15	6515.671	2012	6
6/28/2012	16	6533.27	2012	6
6/28/2012	17	6476.771	2012	6
6/28/2012	18	6297.706	2012	6
6/28/2012	19	6087.47	2012	6
6/28/2012	20	5920.269	2012	6
6/28/2012	21	5588.669	2012	6
6/28/2012	22	5131.975	2012	6
6/28/2012	23	4723.872	2012	6
6/29/2012	0	4417.45	2012	6
6/29/2012	1	4149.27	2012	6
6/29/2012	2	3955.468	2012	6
6/29/2012	3	3852.669	2012	6
6/29/2012	4	3900.664	2012	6
6/29/2012	5	4017.264	2012	6
6/29/2012	6	4230.867	2012	6
6/29/2012	7	4596.971	2012	6
6/29/2012	8	4993.871	2012	6
6/29/2012	9	5487.978	2012	6
6/29/2012	10	5905.872	2012	6
6/29/2012	11	6298.469	2012	6
6/29/2012	12	6621.154	2012	6
6/29/2012	13	6760.069	2012	6
6/29/2012	14	6819.869	2012	6
6/29/2012	15	6855.869	2012	6
6/29/2012	16	6809.669	2012	6
6/29/2012	17	6733.868	2012	6
6/29/2012	18	6323.853	2012	6
6/29/2012	19	6043.056	2012	6
6/29/2012	20	5817.657	2012	6
6/29/2012	21	5521.157	2012	6

Day	Hr	Total	Year	Month
6/29/2012	22	5117.457	2012	6
6/29/2012	23	4711.857	2012	6
6/30/2012	0	4386.157	2012	6
6/30/2012	1	4134.955	2012	6
6/30/2012	2	3882.069	2012	6
6/30/2012	3	3709.45	2012	6
6/30/2012	4	3679.749	2012	6
6/30/2012	5	3628.448	2012	6
6/30/2012	6	3704.444	2012	6
6/30/2012	7	4054.553	2012	6
6/30/2012	8	4472.058	2012	6
6/30/2012	9	4924.857	2012	6
6/30/2012	10	5311.158	2012	6
6/30/2012	11	5651.958	2012	6
6/30/2012	12	5860.557	2012	6
6/30/2012	13	6073.257	2012	6
6/30/2012	14	6241.557	2012	6
6/30/2012	15	6270.156	2012	6
6/30/2012	16	6275.157	2012	6
6/30/2012	17	6269.657	2012	6
6/30/2012	18	6124.258	2012	6
6/30/2012	19	5920.657	2012	6
6/30/2012	20	5770.858	2012	6
6/30/2012	21	5491.357	2012	6
6/30/2012	22	5096.456	2012	6
6/30/2012	23	4724.253	2012	6
7/1/2012	0	4435.45	2012	7
7/1/2012	1	4104.55	2012	7
7/1/2012	2	3901.048	2012	7
7/1/2012	3	3737.447	2012	7
7/1/2012	4	3660.443	2012	7
7/1/2012	5	3666.845	2012	7
7/1/2012	6	3654.25	2012	7
7/1/2012	7	3900.45	2012	7
7/1/2012	8	4207.757	2012	7
7/1/2012	9	4627.158	2012	7
7/1/2012	10	5068.458	2012	7
7/1/2012	11	5406.158	2012	7
7/1/2012	12	5712.808	2012	7
7/1/2012	13	5953.758	2012	7
7/1/2012	14	6099.256	2012	7
7/1/2012	15	6193.158	2012	7
7/1/2012	16	6226.857	2012	7
7/1/2012	17	6183.757	2012	7
7/1/2012	18	6011.565	2012	7
7/1/2012	19	5656.166	2012	7
7/1/2012	20	5345.165	2012	7
7/1/2012	21	4933.162	2012	7
7/1/2012	22	4534.462	2012	7
7/1/2012	23	4202.762	2012	7
7/2/2012	0	3949.062	2012	7
7/2/2012	1	3730.762	2012	7
7/2/2012	2	3593.561	2012	7
7/2/2012	3	3588.862	2012	7
7/2/2012	4	3637.462	2012	7
7/2/2012	5	3795.262	2012	7
7/2/2012	6	3970.363	2012	7
7/2/2012	7	4268.462	2012	7
7/2/2012	8	4638.963	2012	7
7/2/2012	9	5078.868	2012	7
7/2/2012	10	5414.674	2012	7
7/2/2012	11	5779.276	2012	7
7/2/2012	12	6070.476	2012	7
7/2/2012	13	6250.677	2012	7

Day	Hr	Total	Year	Month
7/2/2012	14	6405.877	2012	7
7/2/2012	15	6463.071	2012	7
7/2/2012	16	6453.168	2012	7
7/2/2012	17	6363.568	2012	7
7/2/2012	18	6153.167	2012	7
7/2/2012	19	5958.87	2012	7
7/2/2012	20	5799.668	2012	7
7/2/2012	21	5435.866	2012	7
7/2/2012	22	5009.763	2012	7
7/2/2012	23	4621.262	2012	7
7/3/2012	0	4298.761	2012	7
7/3/2012	1	4028.462	2012	7
7/3/2012	2	3850.762	2012	7
7/3/2012	3	3748.962	2012	7
7/3/2012	4	3761.846	2012	7
7/3/2012	5	3932.053	2012	7
7/3/2012	6	4042.962	2012	7
7/3/2012	7	4372.562	2012	7
7/3/2012	8	4696.178	2012	7
7/3/2012	9	5035.87	2012	7
7/3/2012	10	5355.674	2012	7
7/3/2012	11	5654.176	2012	7
7/3/2012	12	5886.169	2012	7
7/3/2012	13	6074.968	2012	7
7/3/2012	14	6146.156	2012	7
7/3/2012	15	6222.654	2012	7
7/3/2012	16	6181.657	2012	7
7/3/2012	17	6021.357	2012	7
7/3/2012	18	5803.457	2012	7
7/3/2012	19	5610.058	2012	7
7/3/2012	20	5508.758	2012	7
7/3/2012	21	5183.457	2012	7
7/3/2012	22	4804.357	2012	7
7/3/2012	23	4496.757	2012	7
7/4/2012	0	4150.457	2012	7
7/4/2012	1	3930.457	2012	7
7/4/2012	2	3779.757	2012	7
7/4/2012	3	3667.756	2012	7
7/4/2012	4	3602.951	2012	7
7/4/2012	5	3545.048	2012	7
7/4/2012	6	3558.249	2012	7
7/4/2012	7	3831.151	2012	7
7/4/2012	8	4285.528	2012	7
7/4/2012	9	4778.957	2012	7
7/4/2012	10	5201.358	2012	7
7/4/2012	11	5512.759	2012	7
7/4/2012	12	5741.457	2012	7
7/4/2012	13	5866.658	2012	7
7/4/2012	14	5983.057	2012	7
7/4/2012	15	6036.358	2012	7
7/4/2012	16	6046.757	2012	7
7/4/2012	17	5970.658	2012	7
7/4/2012	18	5787.758	2012	7
7/4/2012	19	5589.458	2012	7
7/4/2012	20	5404.158	2012	7
7/4/2012	21	5230.257	2012	7
7/4/2012	22	4960.651	2012	7
7/4/2012	23	4625.551	2012	7
7/5/2012	0	4384.95	2012	7
7/5/2012	1	4126.251	2012	7
7/5/2012	2	3941.051	2012	7
7/5/2012	3	3831.551	2012	7
7/5/2012	4	3935.15	2012	7
7/5/2012	5	4086.25	2012	7

Day	Hr	Total	Year	Month
7/5/2012	6	4358.151	2012	7
7/5/2012	7	4763.152	2012	7
7/5/2012	8	5139.256	2012	7
7/5/2012	9	5627.958	2012	7
7/5/2012	10	6014.159	2012	7
7/5/2012	11	6359.958	2012	7
7/5/2012	12	6588.758	2012	7
7/5/2012	13	6476.157	2012	7
7/5/2012	14	6456.554	2012	7
7/5/2012	15	6225.556	2012	7
7/5/2012	16	6004.457	2012	7
7/5/2012	17	5855.858	2012	7
7/5/2012	18	5657.357	2012	7
7/5/2012	19	5546.258	2012	7
7/5/2012	20	5440.156	2012	7
7/5/2012	21	5121.155	2012	7
7/5/2012	22	4690.051	2012	7
7/5/2012	23	4394.851	2012	7
7/6/2012	0	4076.25	2012	7
7/6/2012	1	3930.85	2012	7
7/6/2012	2	3743.75	2012	7
7/6/2012	3	3631.949	2012	7
7/6/2012	4	3714.545	2012	7
7/6/2012	5	3753.944	2012	7
7/6/2012	6	3970.218	2012	7
7/6/2012	7	4363.355	2012	7
7/6/2012	8	4744.857	2012	7
7/6/2012	9	5199.858	2012	7
7/6/2012	10	5630.357	2012	7
7/6/2012	11	6015.4	2012	7
7/6/2012	12	6352.916	2012	7
7/6/2012	13	6515.957	2012	7
7/6/2012	14	6591.157	2012	7
7/6/2012	15	6640.058	2012	7
7/6/2012	16	6657.257	2012	7
7/6/2012	17	6515.857	2012	7
7/6/2012	18	6340.758	2012	7
7/6/2012	19	6160.458	2012	7
7/6/2012	20	5993.658	2012	7
7/6/2012	21	5671.958	2012	7
7/6/2012	22	5327.757	2012	7
7/6/2012	23	4926.755	2012	7
7/7/2012	0	4599.651	2012	7
7/7/2012	1	4398.15	2012	7
7/7/2012	2	4194.651	2012	7
7/7/2012	3	4027.65	2012	7
7/7/2012	4	3919.95	2012	7
7/7/2012	5	3852.351	2012	7
7/7/2012	6	3934.95	2012	7
7/7/2012	7	4275.252	2012	7
7/7/2012	8	4804.252	2012	7
7/7/2012	9	5277.458	2012	7
7/7/2012	10	5694.759	2012	7
7/7/2012	11	5993.457	2012	7
7/7/2012	12	6156.158	2012	7
7/7/2012	13	6287.957	2012	7
7/7/2012	14	6343.157	2012	7
7/7/2012	15	6401.656	2012	7
7/7/2012	16	6397.058	2012	7
7/7/2012	17	6379.757	2012	7
7/7/2012	18	6210.458	2012	7
7/7/2012	19	5991.358	2012	7
7/7/2012	20	5870.358	2012	7
7/7/2012	21	5608.559	2012	7

Case No. 2018-00295
Attachment 5 to Response to Metro-1 Question No. 37(b)
Page 72 of 823
Bellar

Day	Hr	Total	Year	Month
7/7/2012	22	5283.858	2012	7
7/7/2012	23	4952.354	2012	7
7/8/2012	0	4671.622	2012	7
7/8/2012	1	4426.95	2012	7
7/8/2012	2	4258.751	2012	7
7/8/2012	3	4106.851	2012	7
7/8/2012	4	4035.55	2012	7
7/8/2012	5	3945.55	2012	7
7/8/2012	6	3992.451	2012	7
7/8/2012	7	4273.752	2012	7
7/8/2012	8	4716.262	2012	7
7/8/2012	9	5095.676	2012	7
7/8/2012	10	5454.101	2012	7
7/8/2012	11	5757.277	2012	7
7/8/2012	12	5921.813	2012	7
7/8/2012	13	5953.669	2012	7
7/8/2012	14	5946.169	2012	7
7/8/2012	15	5769.768	2012	7
7/8/2012	16	5493.667	2012	7
7/8/2012	17	5247.077	2012	7
7/8/2012	18	5059.062	2012	7
7/8/2012	19	4815.263	2012	7
7/8/2012	20	4816.551	2012	7
7/8/2012	21	4576.846	2012	7
7/8/2012	22	4293.761	2012	7
7/8/2012	23	3960.262	2012	7
7/9/2012	0	3777.06	2012	7
7/9/2012	1	3639.045	2012	7
7/9/2012	2	3633.06	2012	7
7/9/2012	3	3541.362	2012	7
7/9/2012	4	3741.062	2012	7
7/9/2012	5	3924.153	2012	7
7/9/2012	6	4202.352	2012	7
7/9/2012	7	4459.163	2012	7
7/9/2012	8	4630.162	2012	7
7/9/2012	9	4847.263	2012	7
7/9/2012	10	4992.862	2012	7
7/9/2012	11	5142.263	2012	7
7/9/2012	12	5259.166	2012	7
7/9/2012	13	5271.563	2012	7
7/9/2012	14	5314.166	2012	7
7/9/2012	15	5277.368	2012	7
7/9/2012	16	5286.669	2012	7
7/9/2012	17	5275.569	2012	7
7/9/2012	18	5161.669	2012	7
7/9/2012	19	5031.668	2012	7
7/9/2012	20	4927.365	2012	7
7/9/2012	21	4669.962	2012	7
7/9/2012	22	4279.862	2012	7
7/9/2012	23	3981.157	2012	7
7/10/2012	0	3713.145	2012	7
7/10/2012	1	3554.254	2012	7
7/10/2012	2	3399.462	2012	7
7/10/2012	3	3400.863	2012	7
7/10/2012	4	3500.659	2012	7
7/10/2012	5	3720.946	2012	7
7/10/2012	6	3971.662	2012	7
7/10/2012	7	4283.863	2012	7
7/10/2012	8	4526.362	2012	7
7/10/2012	9	4857.269	2012	7
7/10/2012	10	5178.569	2012	7
7/10/2012	11	5502.07	2012	7
7/10/2012	12	5730.375	2012	7
7/10/2012	13	5899.176	2012	7

Day	Hr	Total	Year	Month
7/10/2012	14	5994.177	2012	7
7/10/2012	15	6004.276	2012	7
7/10/2012	16	5981.677	2012	7
7/10/2012	17	5897.877	2012	7
7/10/2012	18	5760.976	2012	7
7/10/2012	19	5597.676	2012	7
7/10/2012	20	5456.069	2012	7
7/10/2012	21	5106.369	2012	7
7/10/2012	22	4666.268	2012	7
7/10/2012	23	4330.467	2012	7
7/11/2012	0	4063.462	2012	7
7/11/2012	1	3799.662	2012	7
7/11/2012	2	3618.462	2012	7
7/11/2012	3	3530.262	2012	7
7/11/2012	4	3592.962	2012	7
7/11/2012	5	3726.463	2012	7
7/11/2012	6	3983.062	2012	7
7/11/2012	7	4344.858	2012	7
7/11/2012	8	4720.763	2012	7
7/11/2012	9	5078.565	2012	7
7/11/2012	10	5385.165	2012	7
7/11/2012	11	5724.265	2012	7
7/11/2012	12	5947.769	2012	7
7/11/2012	13	6121.272	2012	7
7/11/2012	14	6174.972	2012	7
7/11/2012	15	6153.972	2012	7
7/11/2012	16	6130.771	2012	7
7/11/2012	17	6008.472	2012	7
7/11/2012	18	5806.172	2012	7
7/11/2012	19	5610.276	2012	7
7/11/2012	20	5503.066	2012	7
7/11/2012	21	5214.565	2012	7
7/11/2012	22	4795.063	2012	7
7/11/2012	23	4391.464	2012	7
7/12/2012	0	4096.157	2012	7
7/12/2012	1	3862.749	2012	7
7/12/2012	2	3686.041	2012	7
7/12/2012	3	3619.252	2012	7
7/12/2012	4	3673.557	2012	7
7/12/2012	5	3892.058	2012	7
7/12/2012	6	4112.942	2012	7
7/12/2012	7	4286.053	2012	7
7/12/2012	8	4645.055	2012	7
7/12/2012	9	5033.562	2012	7
7/12/2012	10	5205.065	2012	7
7/12/2012	11	5522.866	2012	7
7/12/2012	12	5649.37	2012	7
7/12/2012	13	5684.271	2012	7
7/12/2012	14	5654.171	2012	7
7/12/2012	15	5542.571	2012	7
7/12/2012	16	5311.37	2012	7
7/12/2012	17	5112.064	2012	7
7/12/2012	18	4899.054	2012	7
7/12/2012	19	4845.347	2012	7
7/12/2012	20	4755.859	2012	7
7/12/2012	21	4559.816	2012	7
7/12/2012	22	4248.15	2012	7
7/12/2012	23	4003.057	2012	7
7/13/2012	0	3752.263	2012	7
7/13/2012	1	3589.363	2012	7
7/13/2012	2	3453.356	2012	7
7/13/2012	3	3403.453	2012	7
7/13/2012	4	3573.763	2012	7
7/13/2012	5	3767.963	2012	7

Day	Hr	Total	Year	Month
7/13/2012	6	3979.552	2012	7
7/13/2012	7	4205.158	2012	7
7/13/2012	8	4371.762	2012	7
7/13/2012	9	4548.251	2012	7
7/13/2012	10	4665.063	2012	7
7/13/2012	11	4819.364	2012	7
7/13/2012	12	4916.864	2012	7
7/13/2012	13	5008.763	2012	7
7/13/2012	14	4993.364	2012	7
7/13/2012	15	5013.464	2012	7
7/13/2012	16	4947.664	2012	7
7/13/2012	17	4860.769	2012	7
7/13/2012	18	4756.87	2012	7
7/13/2012	19	4695.765	2012	7
7/13/2012	20	4699.863	2012	7
7/13/2012	21	4480.863	2012	7
7/13/2012	22	4208.257	2012	7
7/13/2012	23	3938.547	2012	7
7/14/2012	0	3716.35	2012	7
7/14/2012	1	3520.563	2012	7
7/14/2012	2	3407.554	2012	7
7/14/2012	3	3297.053	2012	7
7/14/2012	4	3321.863	2012	7
7/14/2012	5	3288.463	2012	7
7/14/2012	6	3402.049	2012	7
7/14/2012	7	3723.162	2012	7
7/14/2012	8	4133.465	2012	7
7/14/2012	9	4467.97	2012	7
7/14/2012	10	4768.271	2012	7
7/14/2012	11	4947.97	2012	7
7/14/2012	12	4898.269	2012	7
7/14/2012	13	4773.065	2012	7
7/14/2012	14	4555.847	2012	7
7/14/2012	15	4511.354	2012	7
7/14/2012	16	4475.764	2012	7
7/14/2012	17	4475.064	2012	7
7/14/2012	18	4406.063	2012	7
7/14/2012	19	4354.464	2012	7
7/14/2012	20	4280.962	2012	7
7/14/2012	21	4111.846	2012	7
7/14/2012	22	3853.462	2012	7
7/14/2012	23	3672.661	2012	7
7/15/2012	0	3422.947	2012	7
7/15/2012	1	3230.363	2012	7
7/15/2012	2	3119.263	2012	7
7/15/2012	3	3079.454	2012	7
7/15/2012	4	3079.748	2012	7
7/15/2012	5	3077.863	2012	7
7/15/2012	6	3130.664	2012	7
7/15/2012	7	3338.556	2012	7
7/15/2012	8	3605.947	2012	7
7/15/2012	9	3858.557	2012	7
7/15/2012	10	4095.764	2012	7
7/15/2012	11	4289.17	2012	7
7/15/2012	12	4513.071	2012	7
7/15/2012	13	4753.77	2012	7
7/15/2012	14	4931.271	2012	7
7/15/2012	15	5149.072	2012	7
7/15/2012	16	5194.071	2012	7
7/15/2012	17	5135.871	2012	7
7/15/2012	18	5100.371	2012	7
7/15/2012	19	4976.771	2012	7
7/15/2012	20	4954.87	2012	7
7/15/2012	21	4713.97	2012	7

Day	Hr	Total	Year	Month
7/15/2012	22	4426.87	2012	7
7/15/2012	23	4081.147	2012	7
7/16/2012	0	3788.746	2012	7
7/16/2012	1	3620.659	2012	7
7/16/2012	2	3546.361	2012	7
7/16/2012	3	3460.047	2012	7
7/16/2012	4	3592.664	2012	7
7/16/2012	5	3842.763	2012	7
7/16/2012	6	4083.864	2012	7
7/16/2012	7	4462.853	2012	7
7/16/2012	8	4824.154	2012	7
7/16/2012	9	5241.069	2012	7
7/16/2012	10	5558.471	2012	7
7/16/2012	11	5716.772	2012	7
7/16/2012	12	5975.775	2012	7
7/16/2012	13	6115.977	2012	7
7/16/2012	14	6182.378	2012	7
7/16/2012	15	6206.078	2012	7
7/16/2012	16	6175.236	2012	7
7/16/2012	17	6094.078	2012	7
7/16/2012	18	5958.677	2012	7
7/16/2012	19	5812.372	2012	7
7/16/2012	20	5710.67	2012	7
7/16/2012	21	5362.471	2012	7
7/16/2012	22	4923.631	2012	7
7/16/2012	23	4601.569	2012	7
7/17/2012	0	4286.564	2012	7
7/17/2012	1	4095.147	2012	7
7/17/2012	2	3939.964	2012	7
7/17/2012	3	3808.568	2012	7
7/17/2012	4	3897.867	2012	7
7/17/2012	5	4086.759	2012	7
7/17/2012	6	4327.648	2012	7
7/17/2012	7	4732.467	2012	7
7/17/2012	8	5075.071	2012	7
7/17/2012	9	5481.171	2012	7
7/17/2012	10	5857.071	2012	7
7/17/2012	11	6129.777	2012	7
7/17/2012	12	6307.678	2012	7
7/17/2012	13	6404.778	2012	7
7/17/2012	14	6446.578	2012	7
7/17/2012	15	6463.378	2012	7
7/17/2012	16	6450.778	2012	7
7/17/2012	17	6392.271	2012	7
7/17/2012	18	6228.189	2012	7
7/17/2012	19	6083.173	2012	7
7/17/2012	20	5993.676	2012	7
7/17/2012	21	5619.57	2012	7
7/17/2012	22	5230.07	2012	7
7/17/2012	23	4828.17	2012	7
7/18/2012	0	4516.07	2012	7
7/18/2012	1	4300.969	2012	7
7/18/2012	2	4186.47	2012	7
7/18/2012	3	4094.755	2012	7
7/18/2012	4	4176.254	2012	7
7/18/2012	5	4321.567	2012	7
7/18/2012	6	4534.569	2012	7
7/18/2012	7	4893.571	2012	7
7/18/2012	8	5251.871	2012	7
7/18/2012	9	5607.875	2012	7
7/18/2012	10	5889.078	2012	7
7/18/2012	11	6166.878	2012	7
7/18/2012	12	6337.369	2012	7
7/18/2012	13	6514.47	2012	7

Day	Hr	Total	Year	Month
7/18/2012	14	6562.667	2012	7
7/18/2012	15	6448.651	2012	7
7/18/2012	16	6064.759	2012	7
7/18/2012	17	5778.26	2012	7
7/18/2012	18	5501.56	2012	7
7/18/2012	19	5303.159	2012	7
7/18/2012	20	5228.714	2012	7
7/18/2012	21	4868.559	2012	7
7/18/2012	22	4503.959	2012	7
7/18/2012	23	4172.359	2012	7
7/19/2012	0	3877.659	2012	7
7/19/2012	1	3728.559	2012	7
7/19/2012	2	3576.458	2012	7
7/19/2012	3	3531.258	2012	7
7/19/2012	4	3644.658	2012	7
7/19/2012	5	3900.959	2012	7
7/19/2012	6	4126.258	2012	7
7/19/2012	7	4459.459	2012	7
7/19/2012	8	4766.358	2012	7
7/19/2012	9	5121.759	2012	7
7/19/2012	10	5499.558	2012	7
7/19/2012	11	5829.459	2012	7
7/19/2012	12	6131.558	2012	7
7/19/2012	13	6269.658	2012	7
7/19/2012	14	6323.859	2012	7
7/19/2012	15	6281.559	2012	7
7/19/2012	16	6141.158	2012	7
7/19/2012	17	5822.759	2012	7
7/19/2012	18	5350.358	2012	7
7/19/2012	19	5206.258	2012	7
7/19/2012	20	4993.253	2012	7
7/19/2012	21	4742.441	2012	7
7/19/2012	22	4360.241	2012	7
7/19/2012	23	4059.041	2012	7
7/20/2012	0	3860.341	2012	7
7/20/2012	1	3659.054	2012	7
7/20/2012	2	3592.754	2012	7
7/20/2012	3	3550.441	2012	7
7/20/2012	4	3630.045	2012	7
7/20/2012	5	3816.658	2012	7
7/20/2012	6	4053.058	2012	7
7/20/2012	7	4197.647	2012	7
7/20/2012	8	4453.946	2012	7
7/20/2012	9	4694.258	2012	7
7/20/2012	10	4840.358	2012	7
7/20/2012	11	4986.658	2012	7
7/20/2012	12	5171.659	2012	7
7/20/2012	13	5348.758	2012	7
7/20/2012	14	5511.458	2012	7
7/20/2012	15	5501.476	2012	7
7/20/2012	16	5440.777	2012	7
7/20/2012	17	5248.576	2012	7
7/20/2012	18	5057.277	2012	7
7/20/2012	19	4926.176	2012	7
7/20/2012	20	4819.177	2012	7
7/20/2012	21	4578.576	2012	7
7/20/2012	22	4215.076	2012	7
7/20/2012	23	3915.776	2012	7
7/21/2012	0	3648.775	2012	7
7/21/2012	1	3432.392	2012	7
7/21/2012	2	3231.459	2012	7
7/21/2012	3	3174.762	2012	7
7/21/2012	4	3123.576	2012	7
7/21/2012	5	3145.973	2012	7

Day	Hr	Total	Year	Month
7/21/2012	6	3197.663	2012	7
7/21/2012	7	3414.176	2012	7
7/21/2012	8	3734.777	2012	7
7/21/2012	9	4034.534	2012	7
7/21/2012	10	4309.177	2012	7
7/21/2012	11	4499.276	2012	7
7/21/2012	12	4633.677	2012	7
7/21/2012	13	4803.676	2012	7
7/21/2012	14	4918.177	2012	7
7/21/2012	15	5025.677	2012	7
7/21/2012	16	5095.477	2012	7
7/21/2012	17	5091.677	2012	7
7/21/2012	18	4956.476	2012	7
7/21/2012	19	4718.577	2012	7
7/21/2012	20	4596.777	2012	7
7/21/2012	21	4322.476	2012	7
7/21/2012	22	3952.676	2012	7
7/21/2012	23	3629.972	2012	7
7/22/2012	0	3381.159	2012	7
7/22/2012	1	3152.963	2012	7
7/22/2012	2	3066.576	2012	7
7/22/2012	3	2990.569	2012	7
7/22/2012	4	2945.461	2012	7
7/22/2012	5	2870.478	2012	7
7/22/2012	6	2941.675	2012	7
7/22/2012	7	3262.761	2012	7
7/22/2012	8	3649.577	2012	7
7/22/2012	9	4036.376	2012	7
7/22/2012	10	4356.977	2012	7
7/22/2012	11	4727.677	2012	7
7/22/2012	12	4972.876	2012	7
7/22/2012	13	5127.876	2012	7
7/22/2012	14	5263.877	2012	7
7/22/2012	15	5491.677	2012	7
7/22/2012	16	5567.921	2012	7
7/22/2012	17	5525.077	2012	7
7/22/2012	18	5425.577	2012	7
7/22/2012	19	5253.977	2012	7
7/22/2012	20	5131.377	2012	7
7/22/2012	21	4820.176	2012	7
7/22/2012	22	4468.576	2012	7
7/22/2012	23	4158.076	2012	7
7/23/2012	0	3866.276	2012	7
7/23/2012	1	3702.865	2012	7
7/23/2012	2	3659.76	2012	7
7/23/2012	3	3672.476	2012	7
7/23/2012	4	3779.276	2012	7
7/23/2012	5	3999.759	2012	7
7/23/2012	6	4274.772	2012	7
7/23/2012	7	4626.873	2012	7
7/23/2012	8	5022.173	2012	7
7/23/2012	9	5431.173	2012	7
7/23/2012	10	5713.173	2012	7
7/23/2012	11	6032.171	2012	7
7/23/2012	12	6332.164	2012	7
7/23/2012	13	6464.264	2012	7
7/23/2012	14	6521.165	2012	7
7/23/2012	15	6556.964	2012	7
7/23/2012	16	6586.965	2012	7
7/23/2012	17	6511.364	2012	7
7/23/2012	18	6347.555	2012	7
7/23/2012	19	6166.951	2012	7
7/23/2012	20	6101.953	2012	7
7/23/2012	21	5729.254	2012	7

Day	Hr	Total	Year	Month
7/23/2012	22	5295.954	2012	7
7/23/2012	23	4909.155	2012	7
7/24/2012	0	4634.755	2012	7
7/24/2012	1	4411.555	2012	7
7/24/2012	2	4242.556	2012	7
7/24/2012	3	4194.055	2012	7
7/24/2012	4	4258.457	2012	7
7/24/2012	5	4474.656	2012	7
7/24/2012	6	4651.157	2012	7
7/24/2012	7	4825.857	2012	7
7/24/2012	8	5100.757	2012	7
7/24/2012	9	5407.058	2012	7
7/24/2012	10	5646.457	2012	7
7/24/2012	11	5932.258	2012	7
7/24/2012	12	6198.857	2012	7
7/24/2012	13	6351.458	2012	7
7/24/2012	14	6448.557	2012	7
7/24/2012	15	6475.657	2012	7
7/24/2012	16	6466.057	2012	7
7/24/2012	17	6335.158	2012	7
7/24/2012	18	6109.558	2012	7
7/24/2012	19	5930.157	2012	7
7/24/2012	20	5740.858	2012	7
7/24/2012	21	5365.357	2012	7
7/24/2012	22	4984.757	2012	7
7/24/2012	23	4611.557	2012	7
7/25/2012	0	4347.157	2012	7
7/25/2012	1	4140.057	2012	7
7/25/2012	2	3958.657	2012	7
7/25/2012	3	3903.773	2012	7
7/25/2012	4	3970.657	2012	7
7/25/2012	5	4173.758	2012	7
7/25/2012	6	4420.658	2012	7
7/25/2012	7	4746.457	2012	7
7/25/2012	8	5165.458	2012	7
7/25/2012	9	5577.258	2012	7
7/25/2012	10	5924.958	2012	7
7/25/2012	11	6266.258	2012	7
7/25/2012	12	6565.058	2012	7
7/25/2012	13	6740.458	2012	7
7/25/2012	14	6810.857	2012	7
7/25/2012	15	6794.757	2012	7
7/25/2012	16	6765.758	2012	7
7/25/2012	17	6761.257	2012	7
7/25/2012	18	6610.463	2012	7
7/25/2012	19	6389.468	2012	7
7/25/2012	20	6305.967	2012	7
7/25/2012	21	5947.868	2012	7
7/25/2012	22	5518.774	2012	7
7/25/2012	23	5156.476	2012	7
7/26/2012	0	4871.475	2012	7
7/26/2012	1	4624.576	2012	7
7/26/2012	2	4434.376	2012	7
7/26/2012	3	4336.475	2012	7
7/26/2012	4	4359.876	2012	7
7/26/2012	5	4556.376	2012	7
7/26/2012	6	4759.237	2012	7
7/26/2012	7	5120.976	2012	7
7/26/2012	8	5500.977	2012	7
7/26/2012	9	5859.076	2012	7
7/26/2012	10	6176.376	2012	7
7/26/2012	11	6452.776	2012	7
7/26/2012	12	6687.477	2012	7
7/26/2012	13	6763.077	2012	7

Day	Hr	Total	Year	Month
7/26/2012	14	6816.473	2012	7
7/26/2012	15	6749.091	2012	7
7/26/2012	16	6592.168	2012	7
7/26/2012	17	6355.868	2012	7
7/26/2012	18	6037.172	2012	7
7/26/2012	19	5792.776	2012	7
7/26/2012	20	5660.276	2012	7
7/26/2012	21	5299.976	2012	7
7/26/2012	22	4885.276	2012	7
7/26/2012	23	4534.676	2012	7
7/27/2012	0	4257.676	2012	7
7/27/2012	1	4032.169	2012	7
7/27/2012	2	3857.259	2012	7
7/27/2012	3	3808.175	2012	7
7/27/2012	4	3877.875	2012	7
7/27/2012	5	4061.277	2012	7
7/27/2012	6	4232.376	2012	7
7/27/2012	7	4469.776	2012	7
7/27/2012	8	4746.177	2012	7
7/27/2012	9	5065.38	2012	7
7/27/2012	10	5380.077	2012	7
7/27/2012	11	5708.276	2012	7
7/27/2012	12	5961.277	2012	7
7/27/2012	13	6144.376	2012	7
7/27/2012	14	6235.977	2012	7
7/27/2012	15	6278.176	2012	7
7/27/2012	16	6262.278	2012	7
7/27/2012	17	6150.97	2012	7
7/27/2012	18	5801.868	2012	7
7/27/2012	19	5324.675	2012	7
7/27/2012	20	4923.276	2012	7
7/27/2012	21	4676.176	2012	7
7/27/2012	22	4332.275	2012	7
7/27/2012	23	3995.258	2012	7
7/28/2012	0	3723.06	2012	7
7/28/2012	1	3490.376	2012	7
7/28/2012	2	3323.675	2012	7
7/28/2012	3	3208.076	2012	7
7/28/2012	4	3175.775	2012	7
7/28/2012	5	3162.271	2012	7
7/28/2012	6	3224.864	2012	7
7/28/2012	7	3568.776	2012	7
7/28/2012	8	3937.477	2012	7
7/28/2012	9	4234.176	2012	7
7/28/2012	10	4495.676	2012	7
7/28/2012	11	4733.977	2012	7
7/28/2012	12	4913.176	2012	7
7/28/2012	13	5052.977	2012	7
7/28/2012	14	5144.276	2012	7
7/28/2012	15	5228.777	2012	7
7/28/2012	16	5256.676	2012	7
7/28/2012	17	5180.277	2012	7
7/28/2012	18	5017.601	2012	7
7/28/2012	19	4786.876	2012	7
7/28/2012	20	4662.275	2012	7
7/28/2012	21	4364.776	2012	7
7/28/2012	22	4025.676	2012	7
7/28/2012	23	3683.075	2012	7
7/29/2012	0	3422.076	2012	7
7/29/2012	1	3237.575	2012	7
7/29/2012	2	3108.164	2012	7
7/29/2012	3	3012.659	2012	7
7/29/2012	4	2965.176	2012	7
7/29/2012	5	2957.775	2012	7

Day	Hr	Total	Year	Month
7/29/2012	6	2969.377	2012	7
7/29/2012	7	3258.676	2012	7
7/29/2012	8	3617.576	2012	7
7/29/2012	9	3947.876	2012	7
7/29/2012	10	4227.276	2012	7
7/29/2012	11	4515.577	2012	7
7/29/2012	12	4723.236	2012	7
7/29/2012	13	4858.476	2012	7
7/29/2012	14	4961.177	2012	7
7/29/2012	15	5051.876	2012	7
7/29/2012	16	5126.076	2012	7
7/29/2012	17	5077.577	2012	7
7/29/2012	18	4961.992	2012	7
7/29/2012	19	4760.677	2012	7
7/29/2012	20	4690.176	2012	7
7/29/2012	21	4408.075	2012	7
7/29/2012	22	4085.976	2012	7
7/29/2012	23	3753.076	2012	7
7/30/2012	0	3510.669	2012	7
7/30/2012	1	3343.959	2012	7
7/30/2012	2	3243.272	2012	7
7/30/2012	3	3235.676	2012	7
7/30/2012	4	3359.377	2012	7
7/30/2012	5	3588.077	2012	7
7/30/2012	6	3821.57	2012	7
7/30/2012	7	4182.465	2012	7
7/30/2012	8	4529.677	2012	7
7/30/2012	9	4927.376	2012	7
7/30/2012	10	5241.776	2012	7
7/30/2012	11	5539.377	2012	7
7/30/2012	12	5766.076	2012	7
7/30/2012	13	5918.477	2012	7
7/30/2012	14	6033.576	2012	7
7/30/2012	15	6070.477	2012	7
7/30/2012	16	6067.576	2012	7
7/30/2012	17	5995.877	2012	7
7/30/2012	18	5802.08	2012	7
7/30/2012	19	5610.077	2012	7
7/30/2012	20	5482.276	2012	7
7/30/2012	21	5130.476	2012	7
7/30/2012	22	4725.175	2012	7
7/30/2012	23	4362.276	2012	7
7/31/2012	0	4092.876	2012	7
7/31/2012	1	3861.476	2012	7
7/31/2012	2	3679.076	2012	7
7/31/2012	3	3624.163	2012	7
7/31/2012	4	3694.166	2012	7
7/31/2012	5	3904.875	2012	7
7/31/2012	6	4046.077	2012	7
7/31/2012	7	4383.176	2012	7
7/31/2012	8	4783.776	2012	7
7/31/2012	9	5178.077	2012	7
7/31/2012	10	5545.176	2012	7
7/31/2012	11	5833.176	2012	7
7/31/2012	12	6059.776	2012	7
7/31/2012	13	6211.277	2012	7
7/31/2012	14	6312.377	2012	7
7/31/2012	15	6358.976	2012	7
7/31/2012	16	6325.877	2012	7
7/31/2012	17	6219.676	2012	7
7/31/2012	18	6026.576	2012	7
7/31/2012	19	5808.477	2012	7
7/31/2012	20	5710.475	2012	7
7/31/2012	21	5363.476	2012	7

Day	Hr	Total	Year	Month
7/31/2012	22	4972.376	2012	7
7/31/2012	23	4603.089	2012	7
8/1/2012	0	4313.576	2012	8
8/1/2012	1	4051.875	2012	8
8/1/2012	2	3877.067	2012	8
8/1/2012	3	3779.559	2012	8
8/1/2012	4	3844.675	2012	8
8/1/2012	5	4071.676	2012	8
8/1/2012	6	4243.176	2012	8
8/1/2012	7	4547.876	2012	8
8/1/2012	8	4922.177	2012	8
8/1/2012	9	5289.776	2012	8
8/1/2012	10	5674.876	2012	8
8/1/2012	11	6006.917	2012	8
8/1/2012	12	6275.843	2012	8
8/1/2012	13	6391.277	2012	8
8/1/2012	14	6409.576	2012	8
8/1/2012	15	6418.076	2012	8
8/1/2012	16	6348.377	2012	8
8/1/2012	17	6311.376	2012	8
8/1/2012	18	6127.576	2012	8
8/1/2012	19	5864.776	2012	8
8/1/2012	20	5668.576	2012	8
8/1/2012	21	5275.076	2012	8
8/1/2012	22	4826.776	2012	8
8/1/2012	23	4390.075	2012	8
8/2/2012	0	4088.776	2012	8
8/2/2012	1	3822.476	2012	8
8/2/2012	2	3619.276	2012	8
8/2/2012	3	3531.476	2012	8
8/2/2012	4	3622.863	2012	8
8/2/2012	5	3801.867	2012	8
8/2/2012	6	4015.777	2012	8
8/2/2012	7	4311.977	2012	8
8/2/2012	8	4699.576	2012	8
8/2/2012	9	5090.476	2012	8
8/2/2012	10	5484.077	2012	8
8/2/2012	11	5832.276	2012	8
8/2/2012	12	6122.577	2012	8
8/2/2012	13	6265.977	2012	8
8/2/2012	14	6349.686	2012	8
8/2/2012	15	6449.377	2012	8
8/2/2012	16	6395.07	2012	8
8/2/2012	17	6363.768	2012	8
8/2/2012	18	6173.068	2012	8
8/2/2012	19	5933.371	2012	8
8/2/2012	20	5776.376	2012	8
8/2/2012	21	5347.776	2012	8
8/2/2012	22	4918.276	2012	8
8/2/2012	23	4535.476	2012	8
8/3/2012	0	4286.876	2012	8
8/3/2012	1	4061.175	2012	8
8/3/2012	2	3866.268	2012	8
8/3/2012	3	3814.059	2012	8
8/3/2012	4	3885.063	2012	8
8/3/2012	5	4118.575	2012	8
8/3/2012	6	4301.476	2012	8
8/3/2012	7	4412.666	2012	8
8/3/2012	8	4564.768	2012	8
8/3/2012	9	4783.676	2012	8
8/3/2012	10	4907.476	2012	8
8/3/2012	11	5044.477	2012	8
8/3/2012	12	5252.176	2012	8
8/3/2012	13	5276.376	2012	8

Day	Hr	Total	Year	Month
8/3/2012	14	5278.676	2012	8
8/3/2012	15	5247.376	2012	8
8/3/2012	16	5234.676	2012	8
8/3/2012	17	5211.876	2012	8
8/3/2012	18	5074.876	2012	8
8/3/2012	19	4986.676	2012	8
8/3/2012	20	4866.176	2012	8
8/3/2012	21	4706.171	2012	8
8/3/2012	22	4474.059	2012	8
8/3/2012	23	4178.371	2012	8
8/4/2012	0	3974.276	2012	8
8/4/2012	1	3802.668	2012	8
8/4/2012	2	3664.862	2012	8
8/4/2012	3	3545.376	2012	8
8/4/2012	4	3567.576	2012	8
8/4/2012	5	3632.071	2012	8
8/4/2012	6	3656.762	2012	8
8/4/2012	7	3873.876	2012	8
8/4/2012	8	4209.576	2012	8
8/4/2012	9	4546.076	2012	8
8/4/2012	10	4916.676	2012	8
8/4/2012	11	5158.577	2012	8
8/4/2012	12	5363.976	2012	8
8/4/2012	13	5491.576	2012	8
8/4/2012	14	5573.377	2012	8
8/4/2012	15	5466.476	2012	8
8/4/2012	16	5337.277	2012	8
8/4/2012	17	5211.876	2012	8
8/4/2012	18	5015.976	2012	8
8/4/2012	19	4903.976	2012	8
8/4/2012	20	4855.376	2012	8
8/4/2012	21	4631.775	2012	8
8/4/2012	22	4305.764	2012	8
8/4/2012	23	4053.563	2012	8
8/5/2012	0	3836.876	2012	8
8/5/2012	1	3697.776	2012	8
8/5/2012	2	3597.675	2012	8
8/5/2012	3	3538.876	2012	8
8/5/2012	4	3536.876	2012	8
8/5/2012	5	3587.975	2012	8
8/5/2012	6	3600.377	2012	8
8/5/2012	7	3757.459	2012	8
8/5/2012	8	3945.473	2012	8
8/5/2012	9	4122.676	2012	8
8/5/2012	10	4305.476	2012	8
8/5/2012	11	4479.376	2012	8
8/5/2012	12	4640.976	2012	8
8/5/2012	13	4724.676	2012	8
8/5/2012	14	4801.676	2012	8
8/5/2012	15	4882.077	2012	8
8/5/2012	16	4831.476	2012	8
8/5/2012	17	4745.276	2012	8
8/5/2012	18	4638.076	2012	8
8/5/2012	19	4552.676	2012	8
8/5/2012	20	4554.976	2012	8
8/5/2012	21	4321.766	2012	8
8/5/2012	22	4079.059	2012	8
8/5/2012	23	3837.573	2012	8
8/6/2012	0	3628.176	2012	8
8/6/2012	1	3480.766	2012	8
8/6/2012	2	3413.665	2012	8
8/6/2012	3	3388.476	2012	8
8/6/2012	4	3555.776	2012	8
8/6/2012	5	3831.266	2012	8

Day	Hr	Total	Year	Month
8/6/2012	6	4030.975	2012	8
8/6/2012	7	4286.076	2012	8
8/6/2012	8	4573.976	2012	8
8/6/2012	9	4899.5	2012	8
8/6/2012	10	5158.978	2012	8
8/6/2012	11	5411.476	2012	8
8/6/2012	12	5632.377	2012	8
8/6/2012	13	5815.376	2012	8
8/6/2012	14	5926.077	2012	8
8/6/2012	15	5987.676	2012	8
8/6/2012	16	5979.077	2012	8
8/6/2012	17	5898.477	2012	8
8/6/2012	18	5762.276	2012	8
8/6/2012	19	5549.077	2012	8
8/6/2012	20	5455.876	2012	8
8/6/2012	21	5073.076	2012	8
8/6/2012	22	4640.375	2012	8
8/6/2012	23	4262.376	2012	8
8/7/2012	0	3982.976	2012	8
8/7/2012	1	3745.375	2012	8
8/7/2012	2	3558.471	2012	8
8/7/2012	3	3510.659	2012	8
8/7/2012	4	3605.57	2012	8
8/7/2012	5	3836.276	2012	8
8/7/2012	6	4026.677	2012	8
8/7/2012	7	4372.276	2012	8
8/7/2012	8	4733.672	2012	8
8/7/2012	9	5119.671	2012	8
8/7/2012	10	5477.767	2012	8
8/7/2012	11	5756.468	2012	8
8/7/2012	12	5961.567	2012	8
8/7/2012	13	6091.168	2012	8
8/7/2012	14	6167.868	2012	8
8/7/2012	15	6266.268	2012	8
8/7/2012	16	6250.159	2012	8
8/7/2012	17	6179.553	2012	8
8/7/2012	18	6033.757	2012	8
8/7/2012	19	5846.458	2012	8
8/7/2012	20	5691.857	2012	8
8/7/2012	21	5246.058	2012	8
8/7/2012	22	4815.657	2012	8
8/7/2012	23	4437.058	2012	8
8/8/2012	0	4112.857	2012	8
8/8/2012	1	3886.157	2012	8
8/8/2012	2	3706.958	2012	8
8/8/2012	3	3627.057	2012	8
8/8/2012	4	3689.857	2012	8
8/8/2012	5	3945.057	2012	8
8/8/2012	6	4153.858	2012	8
8/8/2012	7	4455.058	2012	8
8/8/2012	8	4829.858	2012	8
8/8/2012	9	5260.558	2012	8
8/8/2012	10	5621.658	2012	8
8/8/2012	11	5953.558	2012	8
8/8/2012	12	6218.958	2012	8
8/8/2012	13	6410.658	2012	8
8/8/2012	14	6537.057	2012	8
8/8/2012	15	6602.958	2012	8
8/8/2012	16	6585.757	2012	8
8/8/2012	17	6499.558	2012	8
8/8/2012	18	6292.258	2012	8
8/8/2012	19	6088.157	2012	8
8/8/2012	20	5944.258	2012	8
8/8/2012	21	5507.258	2012	8

Day	Hr	Total	Year	Month
8/8/2012	22	5075.557	2012	8
8/8/2012	23	4702.758	2012	8
8/9/2012	0	4395.757	2012	8
8/9/2012	1	4154.357	2012	8
8/9/2012	2	4002.758	2012	8
8/9/2012	3	3933.957	2012	8
8/9/2012	4	3994.057	2012	8
8/9/2012	5	4246.658	2012	8
8/9/2012	6	4426.057	2012	8
8/9/2012	7	4612.158	2012	8
8/9/2012	8	4886.057	2012	8
8/9/2012	9	5179.458	2012	8
8/9/2012	10	5479.358	2012	8
8/9/2012	11	5798.4	2012	8
8/9/2012	12	6043.416	2012	8
8/9/2012	13	6186.4	2012	8
8/9/2012	14	6126.522	2012	8
8/9/2012	15	5879.417	2012	8
8/9/2012	16	5591.7	2012	8
8/9/2012	17	5363.621	2012	8
8/9/2012	18	5168.553	2012	8
8/9/2012	19	5109.7	2012	8
8/9/2012	20	4996.151	2012	8
8/9/2012	21	4676.676	2012	8
8/9/2012	22	4316.5	2012	8
8/9/2012	23	4041.051	2012	8
8/10/2012	0	3838.676	2012	8
8/10/2012	1	3928.266	2012	8
8/10/2012	2	3780.609	2012	8
8/10/2012	3	3544.518	2012	8
8/10/2012	4	3623.6	2012	8
8/10/2012	5	3905.088	2012	8
8/10/2012	6	4070.8	2012	8
8/10/2012	7	4268.167	2012	8
8/10/2012	8	4403.652	2012	8
8/10/2012	9	4560.677	2012	8
8/10/2012	10	4789.076	2012	8
8/10/2012	11	4982.576	2012	8
8/10/2012	12	5107.676	2012	8
8/10/2012	13	5156.2	2012	8
8/10/2012	14	5168.353	2012	8
8/10/2012	15	5181.277	2012	8
8/10/2012	16	5172.076	2012	8
8/10/2012	17	5051.377	2012	8
8/10/2012	18	4781.776	2012	8
8/10/2012	19	4594.476	2012	8
8/10/2012	20	4487.576	2012	8
8/10/2012	21	4207.576	2012	8
8/10/2012	22	3884.276	2012	8
8/10/2012	23	3567.276	2012	8
8/11/2012	0	3322.276	2012	8
8/11/2012	1	3129.177	2012	8
8/11/2012	2	3002.877	2012	8
8/11/2012	3	2891.478	2012	8
8/11/2012	4	2884.078	2012	8
8/11/2012	5	2927.676	2012	8
8/11/2012	6	2933.262	2012	8
8/11/2012	7	3142.576	2012	8
8/11/2012	8	3412.376	2012	8
8/11/2012	9	3599.277	2012	8
8/11/2012	10	3797.776	2012	8
8/11/2012	11	3930.777	2012	8
8/11/2012	12	4045.576	2012	8
8/11/2012	13	4130.077	2012	8

Day	Hr	Total	Year	Month
8/11/2012	14	4266.176	2012	8
8/11/2012	15	4400.377	2012	8
8/11/2012	16	4486.577	2012	8
8/11/2012	17	4458.976	2012	8
8/11/2012	18	4349.234	2012	8
8/11/2012	19	4121.576	2012	8
8/11/2012	20	4043.176	2012	8
8/11/2012	21	3757.575	2012	8
8/11/2012	22	3457.776	2012	8
8/11/2012	23	3146.377	2012	8
8/12/2012	0	2943.276	2012	8
8/12/2012	1	2794.675	2012	8
8/12/2012	2	2705.559	2012	8
8/12/2012	3	2658.573	2012	8
8/12/2012	4	2642.777	2012	8
8/12/2012	5	2642.777	2012	8
8/12/2012	6	2683.977	2012	8
8/12/2012	7	2851.364	2012	8
8/12/2012	8	3130.774	2012	8
8/12/2012	9	3383.276	2012	8
8/12/2012	10	3617.776	2012	8
8/12/2012	11	3858.776	2012	8
8/12/2012	12	4041.577	2012	8
8/12/2012	13	4194.276	2012	8
8/12/2012	14	4421.577	2012	8
8/12/2012	15	4581.377	2012	8
8/12/2012	16	4639.677	2012	8
8/12/2012	17	4609.076	2012	8
8/12/2012	18	4446.976	2012	8
8/12/2012	19	4339.176	2012	8
8/12/2012	20	4314.376	2012	8
8/12/2012	21	4012.776	2012	8
8/12/2012	22	3709.075	2012	8
8/12/2012	23	3433.676	2012	8
8/13/2012	0	3258.076	2012	8
8/13/2012	1	3145.676	2012	8
8/13/2012	2	3050.576	2012	8
8/13/2012	3	3059.363	2012	8
8/13/2012	4	3196.368	2012	8
8/13/2012	5	3446.977	2012	8
8/13/2012	6	3660.378	2012	8
8/13/2012	7	3916.577	2012	8
8/13/2012	8	4174.777	2012	8
8/13/2012	9	4397.7	2012	8
8/13/2012	10	4520.952	2012	8
8/13/2012	11	4619.16	2012	8
8/13/2012	12	4620.27	2012	8
8/13/2012	13	4619.2	2012	8
8/13/2012	14	4687.576	2012	8
8/13/2012	15	4726.652	2012	8
8/13/2012	16	4722.502	2012	8
8/13/2012	17	4660.976	2012	8
8/13/2012	18	4585.776	2012	8
8/13/2012	19	4567.876	2012	8
8/13/2012	20	4532.876	2012	8
8/13/2012	21	4272.975	2012	8
8/13/2012	22	3945.065	2012	8
8/13/2012	23	3706.965	2012	8
8/14/2012	0	3523.176	2012	8
8/14/2012	1	3363.775	2012	8
8/14/2012	2	3267.464	2012	8
8/14/2012	3	3254.867	2012	8
8/14/2012	4	3406.976	2012	8
8/14/2012	5	3714.176	2012	8

Day	Hr	Total	Year	Month
8/14/2012	6	3950.376	2012	8
8/14/2012	7	4102.576	2012	8
8/14/2012	8	4305.376	2012	8
8/14/2012	9	4503.276	2012	8
8/14/2012	10	4644.377	2012	8
8/14/2012	11	4833.4	2012	8
8/14/2012	12	4966.576	2012	8
8/14/2012	13	5157.576	2012	8
8/14/2012	14	5239.553	2012	8
8/14/2012	15	5274.377	2012	8
8/14/2012	16	5251.9	2012	8
8/14/2012	17	5102.852	2012	8
8/14/2012	18	4900.176	2012	8
8/14/2012	19	4836.876	2012	8
8/14/2012	20	4741.476	2012	8
8/14/2012	21	4401.176	2012	8
8/14/2012	22	4038.575	2012	8
8/14/2012	23	3756.458	2012	8
8/15/2012	0	3526.569	2012	8
8/15/2012	1	3387.5	2012	8
8/15/2012	2	3276.576	2012	8
8/15/2012	3	3237.551	2012	8
8/15/2012	4	3389.5	2012	8
8/15/2012	5	3730.234	2012	8
8/15/2012	6	3950.977	2012	8
8/15/2012	7	4105.277	2012	8
8/15/2012	8	4350.576	2012	8
8/15/2012	9	4633.576	2012	8
8/15/2012	10	4852.977	2012	8
8/15/2012	11	5083.176	2012	8
8/15/2012	12	5280.377	2012	8
8/15/2012	13	5462.576	2012	8
8/15/2012	14	5575.177	2012	8
8/15/2012	15	5633.377	2012	8
8/15/2012	16	5650.176	2012	8
8/15/2012	17	5573.375	2012	8
8/15/2012	18	5408.377	2012	8
8/15/2012	19	5207.976	2012	8
8/15/2012	20	5035.476	2012	8
8/15/2012	21	4634.376	2012	8
8/15/2012	22	4212.276	2012	8
8/15/2012	23	3879.075	2012	8
8/16/2012	0	3639.377	2012	8
8/16/2012	1	3439.46	2012	8
8/16/2012	2	3273.062	2012	8
8/16/2012	3	3232.277	2012	8
8/16/2012	4	3344.668	2012	8
8/16/2012	5	3658.478	2012	8
8/16/2012	6	3863.279	2012	8
8/16/2012	7	4068.276	2012	8
8/16/2012	8	4382.877	2012	8
8/16/2012	9	4695.276	2012	8
8/16/2012	10	4995.177	2012	8
8/16/2012	11	5314.876	2012	8
8/16/2012	12	5595.677	2012	8
8/16/2012	13	5809.576	2012	8
8/16/2012	14	5910.576	2012	8
8/16/2012	15	5979.377	2012	8
8/16/2012	16	5961.876	2012	8
8/16/2012	17	5807.476	2012	8
8/16/2012	18	5615.177	2012	8
8/16/2012	19	5518.275	2012	8
8/16/2012	20	5150.876	2012	8
8/16/2012	21	4722.868	2012	8

Day	Hr	Total	Year	Month
8/16/2012	22	4296.659	2012	8
8/16/2012	23	3941.664	2012	8
8/17/2012	0	3704.176	2012	8
8/17/2012	1	3529.275	2012	8
8/17/2012	2	3408.576	2012	8
8/17/2012	3	3356.175	2012	8
8/17/2012	4	3464.959	2012	8
8/17/2012	5	3803.175	2012	8
8/17/2012	6	4026.177	2012	8
8/17/2012	7	4152.2	2012	8
8/17/2012	8	4281.71	2012	8
8/17/2012	9	4375.9	2012	8
8/17/2012	10	4449.852	2012	8
8/17/2012	11	4525.777	2012	8
8/17/2012	12	4675.776	2012	8
8/17/2012	13	4798.177	2012	8
8/17/2012	14	4908.876	2012	8
8/17/2012	15	4968.777	2012	8
8/17/2012	16	4996.876	2012	8
8/17/2012	17	4906.776	2012	8
8/17/2012	18	4724.076	2012	8
8/17/2012	19	4536.576	2012	8
8/17/2012	20	4414.276	2012	8
8/17/2012	21	4134.376	2012	8
8/17/2012	22	3788.476	2012	8
8/17/2012	23	3471.076	2012	8
8/18/2012	0	3253.676	2012	8
8/18/2012	1	3057.677	2012	8
8/18/2012	2	2934.679	2012	8
8/18/2012	3	2850.678	2012	8
8/18/2012	4	2865.578	2012	8
8/18/2012	5	2925.778	2012	8
8/18/2012	6	2933.763	2012	8
8/18/2012	7	3139.472	2012	8
8/18/2012	8	3386.777	2012	8
8/18/2012	9	3682.276	2012	8
8/18/2012	10	3888.076	2012	8
8/18/2012	11	4043.477	2012	8
8/18/2012	12	4183.176	2012	8
8/18/2012	13	4324.276	2012	8
8/18/2012	14	4471.476	2012	8
8/18/2012	15	4561.301	2012	8
8/18/2012	16	4565.576	2012	8
8/18/2012	17	4472.977	2012	8
8/18/2012	18	4312.176	2012	8
8/18/2012	19	4167.476	2012	8
8/18/2012	20	4056.976	2012	8
8/18/2012	21	3765.675	2012	8
8/18/2012	22	3468.177	2012	8
8/18/2012	23	3210.877	2012	8
8/19/2012	0	3016.464	2012	8
8/19/2012	1	2865.269	2012	8
8/19/2012	2	2789.777	2012	8
8/19/2012	3	2730.477	2012	8
8/19/2012	4	2732.377	2012	8
8/19/2012	5	2750.577	2012	8
8/19/2012	6	2749.377	2012	8
8/19/2012	7	2947.779	2012	8
8/19/2012	8	3229.376	2012	8
8/19/2012	9	3486.977	2012	8
8/19/2012	10	3740.976	2012	8
8/19/2012	11	3964.576	2012	8
8/19/2012	12	4152.276	2012	8
8/19/2012	13	4286.477	2012	8

Day	Hr	Total	Year	Month
8/19/2012	14	4417.376	2012	8
8/19/2012	15	4529.377	2012	8
8/19/2012	16	4614.152	2012	8
8/19/2012	17	4537.376	2012	8
8/19/2012	18	4408.977	2012	8
8/19/2012	19	4285.476	2012	8
8/19/2012	20	4173.076	2012	8
8/19/2012	21	3855.964	2012	8
8/19/2012	22	3514.167	2012	8
8/19/2012	23	3240.578	2012	8
8/20/2012	0	3037.478	2012	8
8/20/2012	1	2917.479	2012	8
8/20/2012	2	2872.178	2012	8
8/20/2012	3	2871.578	2012	8
8/20/2012	4	3051.378	2012	8
8/20/2012	5	3381.278	2012	8
8/20/2012	6	3578.979	2012	8
8/20/2012	7	3790.271	2012	8
8/20/2012	8	4020.566	2012	8
8/20/2012	9	4229.576	2012	8
8/20/2012	10	4438.076	2012	8
8/20/2012	11	4641.376	2012	8
8/20/2012	12	4790.476	2012	8
8/20/2012	13	4946.076	2012	8
8/20/2012	14	5016.077	2012	8
8/20/2012	15	5093.976	2012	8
8/20/2012	16	5099.876	2012	8
8/20/2012	17	5043.876	2012	8
8/20/2012	18	4878.977	2012	8
8/20/2012	19	4721.276	2012	8
8/20/2012	20	4576.976	2012	8
8/20/2012	21	4222.075	2012	8
8/20/2012	22	3809.076	2012	8
8/20/2012	23	3505.977	2012	8
8/21/2012	0	3279.777	2012	8
8/21/2012	1	3120.577	2012	8
8/21/2012	2	3041.963	2012	8
8/21/2012	3	2992.072	2012	8
8/21/2012	4	3143.078	2012	8
8/21/2012	5	3486.278	2012	8
8/21/2012	6	3673.479	2012	8
8/21/2012	7	3823.978	2012	8
8/21/2012	8	4035.577	2012	8
8/21/2012	9	4239.476	2012	8
8/21/2012	10	4436.177	2012	8
8/21/2012	11	4664.976	2012	8
8/21/2012	12	4774.276	2012	8
8/21/2012	13	4869.376	2012	8
8/21/2012	14	4841.176	2012	8
8/21/2012	15	4889.076	2012	8
8/21/2012	16	4885.577	2012	8
8/21/2012	17	4802.776	2012	8
8/21/2012	18	4650.276	2012	8
8/21/2012	19	4558.176	2012	8
8/21/2012	20	4454.075	2012	8
8/21/2012	21	4077.069	2012	8
8/21/2012	22	3732.061	2012	8
8/21/2012	23	3407.277	2012	8
8/22/2012	0	3212.978	2012	8
8/22/2012	1	3081.778	2012	8
8/22/2012	2	2956.078	2012	8
8/22/2012	3	2943.778	2012	8
8/22/2012	4	3053.479	2012	8
8/22/2012	5	3425.478	2012	8

Day	Hr	Total	Year	Month
8/22/2012	6	3629.274	2012	8
8/22/2012	7	3803.262	2012	8
8/22/2012	8	4005.878	2012	8
8/22/2012	9	4255.676	2012	8
8/22/2012	10	4439.676	2012	8
8/22/2012	11	4693.076	2012	8
8/22/2012	12	4907.177	2012	8
8/22/2012	13	5107.776	2012	8
8/22/2012	14	5223.076	2012	8
8/22/2012	15	5389.977	2012	8
8/22/2012	16	5383.176	2012	8
8/22/2012	17	5386.177	2012	8
8/22/2012	18	5181.976	2012	8
8/22/2012	19	4985.476	2012	8
8/22/2012	20	4799.776	2012	8
8/22/2012	21	4367.676	2012	8
8/22/2012	22	3941.476	2012	8
8/22/2012	23	3602.277	2012	8
8/23/2012	0	3369.378	2012	8
8/23/2012	1	3201.579	2012	8
8/23/2012	2	3078.778	2012	8
8/23/2012	3	3032.063	2012	8
8/23/2012	4	3179.071	2012	8
8/23/2012	5	3531.078	2012	8
8/23/2012	6	3702.879	2012	8
8/23/2012	7	3848.178	2012	8
8/23/2012	8	4138.938	2012	8
8/23/2012	9	4414.976	2012	8
8/23/2012	10	4685.076	2012	8
8/23/2012	11	4960.376	2012	8
8/23/2012	12	5236.177	2012	8
8/23/2012	13	5468.276	2012	8
8/23/2012	14	5613.777	2012	8
8/23/2012	15	5754.776	2012	8
8/23/2012	16	5804.077	2012	8
8/23/2012	17	5650.176	2012	8
8/23/2012	18	5480.877	2012	8
8/23/2012	19	5345.576	2012	8
8/23/2012	20	5092.976	2012	8
8/23/2012	21	4657.176	2012	8
8/23/2012	22	4188.775	2012	8
8/23/2012	23	3828.077	2012	8
8/24/2012	0	3575.471	2012	8
8/24/2012	1	3387.261	2012	8
8/24/2012	2	3238.976	2012	8
8/24/2012	3	3177.478	2012	8
8/24/2012	4	3288.279	2012	8
8/24/2012	5	3599.478	2012	8
8/24/2012	6	3775.678	2012	8
8/24/2012	7	3987.278	2012	8
8/24/2012	8	4258.776	2012	8
8/24/2012	9	4588.476	2012	8
8/24/2012	10	4862.176	2012	8
8/24/2012	11	5245.477	2012	8
8/24/2012	12	5536.976	2012	8
8/24/2012	13	5738.776	2012	8
8/24/2012	14	5876.576	2012	8
8/24/2012	15	5951.076	2012	8
8/24/2012	16	5938.376	2012	8
8/24/2012	17	5823.576	2012	8
8/24/2012	18	5564.876	2012	8
8/24/2012	19	5344.875	2012	8
8/24/2012	20	5100.676	2012	8
8/24/2012	21	4696.176	2012	8

Day	Hr	Total	Year	Month
8/24/2012	22	4291.075	2012	8
8/24/2012	23	3928.176	2012	8
8/25/2012	0	3674.176	2012	8
8/25/2012	1	3446.563	2012	8
8/25/2012	2	3280.258	2012	8
8/25/2012	3	3167.374	2012	8
8/25/2012	4	3160.177	2012	8
8/25/2012	5	3197.577	2012	8
8/25/2012	6	3220.377	2012	8
8/25/2012	7	3454.577	2012	8
8/25/2012	8	3829.776	2012	8
8/25/2012	9	4216.676	2012	8
8/25/2012	10	4601.076	2012	8
8/25/2012	11	4916.577	2012	8
8/25/2012	12	5176.376	2012	8
8/25/2012	13	5330.876	2012	8
8/25/2012	14	5429.877	2012	8
8/25/2012	15	5461.976	2012	8
8/25/2012	16	5431.777	2012	8
8/25/2012	17	5348.976	2012	8
8/25/2012	18	5158.677	2012	8
8/25/2012	19	4983.376	2012	8
8/25/2012	20	4804.675	2012	8
8/25/2012	21	4435.876	2012	8
8/25/2012	22	4059.276	2012	8
8/25/2012	23	3732.775	2012	8
8/26/2012	0	3490.676	2012	8
8/26/2012	1	3288.275	2012	8
8/26/2012	2	3161.564	2012	8
8/26/2012	3	3052.36	2012	8
8/26/2012	4	3035.176	2012	8
8/26/2012	5	3048.576	2012	8
8/26/2012	6	3005.475	2012	8
8/26/2012	7	3295.962	2012	8
8/26/2012	8	3683.496	2012	8
8/26/2012	9	4062.676	2012	8
8/26/2012	10	4455.676	2012	8
8/26/2012	11	4781.777	2012	8
8/26/2012	12	5001.376	2012	8
8/26/2012	13	5209.877	2012	8
8/26/2012	14	5337.876	2012	8
8/26/2012	15	5421.176	2012	8
8/26/2012	16	5478.576	2012	8
8/26/2012	17	5393.977	2012	8
8/26/2012	18	5248.976	2012	8
8/26/2012	19	5165.576	2012	8
8/26/2012	20	5013.075	2012	8
8/26/2012	21	4608.476	2012	8
8/26/2012	22	4231.876	2012	8
8/26/2012	23	3912.975	2012	8
8/27/2012	0	3714.376	2012	8
8/27/2012	1	3541.576	2012	8
8/27/2012	2	3452.475	2012	8
8/27/2012	3	3440.476	2012	8
8/27/2012	4	3577.966	2012	8
8/27/2012	5	3949.06	2012	8
8/27/2012	6	4182.176	2012	8
8/27/2012	7	4452.976	2012	8
8/27/2012	8	4756.677	2012	8
8/27/2012	9	5107.077	2012	8
8/27/2012	10	5415.776	2012	8
8/27/2012	11	5756.71	2012	8
8/27/2012	12	5956.776	2012	8
8/27/2012	13	6009.777	2012	8

Day	Hr	Total	Year	Month
8/27/2012	14	5969.376	2012	8
8/27/2012	15	5973.176	2012	8
8/27/2012	16	5874.276	2012	8
8/27/2012	17	5746.576	2012	8
8/27/2012	18	5552.976	2012	8
8/27/2012	19	5483.276	2012	8
8/27/2012	20	5272.059	2012	8
8/27/2012	21	4865.862	2012	8
8/27/2012	22	4478.976	2012	8
8/27/2012	23	4164.076	2012	8
8/28/2012	0	3945.475	2012	8
8/28/2012	1	3774.576	2012	8
8/28/2012	2	3663.575	2012	8
8/28/2012	3	3602.075	2012	8
8/28/2012	4	3749.176	2012	8
8/28/2012	5	4071.775	2012	8
8/28/2012	6	4271.777	2012	8
8/28/2012	7	4381.576	2012	8
8/28/2012	8	4595.576	2012	8
8/28/2012	9	4825.576	2012	8
8/28/2012	10	5073.176	2012	8
8/28/2012	11	5324.777	2012	8
8/28/2012	12	5593.376	2012	8
8/28/2012	13	5745.976	2012	8
8/28/2012	14	5861.877	2012	8
8/28/2012	15	5934.176	2012	8
8/28/2012	16	5901.676	2012	8
8/28/2012	17	5808.477	2012	8
8/28/2012	18	5581.176	2012	8
8/28/2012	19	5440.276	2012	8
8/28/2012	20	5170.376	2012	8
8/28/2012	21	4740.175	2012	8
8/28/2012	22	4299.176	2012	8
8/28/2012	23	3906.475	2012	8
8/29/2012	0	3704.676	2012	8
8/29/2012	1	3487.975	2012	8
8/29/2012	2	3346.276	2012	8
8/29/2012	3	3261.575	2012	8
8/29/2012	4	3410.476	2012	8
8/29/2012	5	3753.87	2012	8
8/29/2012	6	3937.759	2012	8
8/29/2012	7	4103.976	2012	8
8/29/2012	8	4387.576	2012	8
8/29/2012	9	4656.576	2012	8
8/29/2012	10	5004.376	2012	8
8/29/2012	11	5294.876	2012	8
8/29/2012	12	5529.277	2012	8
8/29/2012	13	5727.076	2012	8
8/29/2012	14	5851.476	2012	8
8/29/2012	15	5951.576	2012	8
8/29/2012	16	5895.576	2012	8
8/29/2012	17	5777.077	2012	8
8/29/2012	18	5524.676	2012	8
8/29/2012	19	5360.576	2012	8
8/29/2012	20	5098.675	2012	8
8/29/2012	21	4641.076	2012	8
8/29/2012	22	4199.276	2012	8
8/29/2012	23	3816.375	2012	8
8/30/2012	0	3578.776	2012	8
8/30/2012	1	3363.876	2012	8
8/30/2012	2	3207.176	2012	8
8/30/2012	3	3177.177	2012	8
8/30/2012	4	3287.577	2012	8
8/30/2012	5	3621.669	2012	8

Day	Hr	Total	Year	Month
8/30/2012	6	3821.061	2012	8
8/30/2012	7	3988.777	2012	8
8/30/2012	8	4244.976	2012	8
8/30/2012	9	4546.476	2012	8
8/30/2012	10	4862.676	2012	8
8/30/2012	11	5194.176	2012	8
8/30/2012	12	5507.677	2012	8
8/30/2012	13	5765.976	2012	8
8/30/2012	14	5972.977	2012	8
8/30/2012	15	6119.276	2012	8
8/30/2012	16	6130.576	2012	8
8/30/2012	17	6039.577	2012	8
8/30/2012	18	5866.476	2012	8
8/30/2012	19	5803.976	2012	8
8/30/2012	20	5617.876	2012	8
8/30/2012	21	5198.976	2012	8
8/30/2012	22	4741.776	2012	8
8/30/2012	23	4367.075	2012	8
8/31/2012	0	4088.464	2012	8
8/31/2012	1	3884.76	2012	8
8/31/2012	2	3712.376	2012	8
8/31/2012	3	3649.775	2012	8
8/31/2012	4	3748.876	2012	8
8/31/2012	5	4088.976	2012	8
8/31/2012	6	4333.463	2012	8
8/31/2012	7	4578.87	2012	8
8/31/2012	8	4825.076	2012	8
8/31/2012	9	5099.777	2012	8
8/31/2012	10	5345.476	2012	8
8/31/2012	11	5465.177	2012	8
8/31/2012	12	5595.873	2012	8
8/31/2012	13	5660.773	2012	8
8/31/2012	14	5666.157	2012	8
8/31/2012	15	5781.857	2012	8
8/31/2012	16	5791.258	2012	8
8/31/2012	17	5658.758	2012	8
8/31/2012	18	5473.658	2012	8
8/31/2012	19	5438.358	2012	8
8/31/2012	20	5270.758	2012	8
8/31/2012	21	4958.457	2012	8
8/31/2012	22	4593.858	2012	8
8/31/2012	23	4262.057	2012	8
9/1/2012	0	4005.358	2012	9
9/1/2012	1	3774.957	2012	9
9/1/2012	2	3622.858	2012	9
9/1/2012	3	3503.657	2012	9
9/1/2012	4	3519.858	2012	9
9/1/2012	5	3538.157	2012	9
9/1/2012	6	3590.058	2012	9
9/1/2012	7	3753.058	2012	9
9/1/2012	8	4075.358	2012	9
9/1/2012	9	4400.057	2012	9
9/1/2012	10	4611.458	2012	9
9/1/2012	11	4788.458	2012	9
9/1/2012	12	4959.558	2012	9
9/1/2012	13	5083.558	2012	9
9/1/2012	14	5108.658	2012	9
9/1/2012	15	5020.357	2012	9
9/1/2012	16	5010.758	2012	9
9/1/2012	17	4938.057	2012	9
9/1/2012	18	4810.958	2012	9
9/1/2012	19	4795.457	2012	9
9/1/2012	20	4601.857	2012	9
9/1/2012	21	4361.657	2012	9

Day	Hr	Total	Year	Month
9/1/2012	22	4046.357	2012	9
9/1/2012	23	3792.557	2012	9
9/2/2012	0	3566.357	2012	9
9/2/2012	1	3408.757	2012	9
9/2/2012	2	3323.657	2012	9
9/2/2012	3	3227.857	2012	9
9/2/2012	4	3239.958	2012	9
9/2/2012	5	3283.757	2012	9
9/2/2012	6	3372.757	2012	9
9/2/2012	7	3510.157	2012	9
9/2/2012	8	3768.358	2012	9
9/2/2012	9	3988.558	2012	9
9/2/2012	10	4074.457	2012	9
9/2/2012	11	4186.058	2012	9
9/2/2012	12	4251.257	2012	9
9/2/2012	13	4175.643	2012	9
9/2/2012	14	4221.747	2012	9
9/2/2012	15	4170.76	2012	9
9/2/2012	16	4162.076	2012	9
9/2/2012	17	4083.976	2012	9
9/2/2012	18	4053.476	2012	9
9/2/2012	19	4102.376	2012	9
9/2/2012	20	4026.376	2012	9
9/2/2012	21	3838.959	2012	9
9/2/2012	22	3602.871	2012	9
9/2/2012	23	3397.376	2012	9
9/3/2012	0	3271.376	2012	9
9/3/2012	1	3144.366	2012	9
9/3/2012	2	3096.167	2012	9
9/3/2012	3	3062.576	2012	9
9/3/2012	4	3120.376	2012	9
9/3/2012	5	3221.37	2012	9
9/3/2012	6	3268.564	2012	9
9/3/2012	7	3364.376	2012	9
9/3/2012	8	3620.576	2012	9
9/3/2012	9	3859.477	2012	9
9/3/2012	10	4036.963	2012	9
9/3/2012	11	4185.976	2012	9
9/3/2012	12	4224.976	2012	9
9/3/2012	13	4403.476	2012	9
9/3/2012	14	4512.876	2012	9
9/3/2012	15	4545.576	2012	9
9/3/2012	16	4595.676	2012	9
9/3/2012	17	4555.376	2012	9
9/3/2012	18	4485.671	2012	9
9/3/2012	19	4563.957	2012	9
9/3/2012	20	4440.276	2012	9
9/3/2012	21	4188.676	2012	9
9/3/2012	22	3819.776	2012	9
9/3/2012	23	3643.061	2012	9
9/4/2012	0	3491.174	2012	9
9/4/2012	1	3339.776	2012	9
9/4/2012	2	3253.476	2012	9
9/4/2012	3	3269.259	2012	9
9/4/2012	4	3488.876	2012	9
9/4/2012	5	3889.477	2012	9
9/4/2012	6	4222.876	2012	9
9/4/2012	7	4349.46	2012	9
9/4/2012	8	4532.276	2012	9
9/4/2012	9	4694.477	2012	9
9/4/2012	10	4848.162	2012	9
9/4/2012	11	5064.87	2012	9
9/4/2012	12	5317.06	2012	9
9/4/2012	13	5543.259	2012	9

Day	Hr	Total	Year	Month
9/4/2012	14	5727.959	2012	9
9/4/2012	15	5830.962	2012	9
9/4/2012	16	5899.562	2012	9
9/4/2012	17	5828.563	2012	9
9/4/2012	18	5655.062	2012	9
9/4/2012	19	5652.062	2012	9
9/4/2012	20	5428.162	2012	9
9/4/2012	21	4992.362	2012	9
9/4/2012	22	4559.262	2012	9
9/4/2012	23	4238.362	2012	9
9/5/2012	0	3904.462	2012	9
9/5/2012	1	3708.162	2012	9
9/5/2012	2	3609.562	2012	9
9/5/2012	3	3604.662	2012	9
9/5/2012	4	3770.361	2012	9
9/5/2012	5	4122.462	2012	9
9/5/2012	6	4294.762	2012	9
9/5/2012	7	4492.163	2012	9
9/5/2012	8	4816.862	2012	9
9/5/2012	9	5171.663	2012	9
9/5/2012	10	5572.663	2012	9
9/5/2012	11	5868.362	2012	9
9/5/2012	12	6052.163	2012	9
9/5/2012	13	6152.162	2012	9
9/5/2012	14	6153.763	2012	9
9/5/2012	15	5805.262	2012	9
9/5/2012	16	5470.162	2012	9
9/5/2012	17	5201.862	2012	9
9/5/2012	18	5025.962	2012	9
9/5/2012	19	4995.662	2012	9
9/5/2012	20	4761.761	2012	9
9/5/2012	21	4428.461	2012	9
9/5/2012	22	4099.362	2012	9
9/5/2012	23	3778.361	2012	9
9/6/2012	0	3589.762	2012	9
9/6/2012	1	3470.562	2012	9
9/6/2012	2	3394.561	2012	9
9/6/2012	3	3346.762	2012	9
9/6/2012	4	3472.861	2012	9
9/6/2012	5	3897.062	2012	9
9/6/2012	6	4125.562	2012	9
9/6/2012	7	4267.967	2012	9
9/6/2012	8	4345.181	2012	9
9/6/2012	9	4606.58	2012	9
9/6/2012	10	4838.182	2012	9
9/6/2012	11	5086.681	2012	9
9/6/2012	12	5388.181	2012	9
9/6/2012	13	5592.18	2012	9
9/6/2012	14	5772.981	2012	9
9/6/2012	15	5842.179	2012	9
9/6/2012	16	5872.173	2012	9
9/6/2012	17	5766.172	2012	9
9/6/2012	18	5558.672	2012	9
9/6/2012	19	5532.68	2012	9
9/6/2012	20	5261.78	2012	9
9/6/2012	21	4863.88	2012	9
9/6/2012	22	4437.281	2012	9
9/6/2012	23	4104.242	2012	9
9/7/2012	0	3866.88	2012	9
9/7/2012	1	3620.48	2012	9
9/7/2012	2	3501.58	2012	9
9/7/2012	3	3435.78	2012	9
9/7/2012	4	3539.98	2012	9
9/7/2012	5	3897.68	2012	9

Day	Hr	Total	Year	Month
9/7/2012	6	4123.681	2012	9
9/7/2012	7	4289.78	2012	9
9/7/2012	8	4547.381	2012	9
9/7/2012	9	4892.981	2012	9
9/7/2012	10	5240.281	2012	9
9/7/2012	11	5530.881	2012	9
9/7/2012	12	5779.481	2012	9
9/7/2012	13	5951.081	2012	9
9/7/2012	14	6061.581	2012	9
9/7/2012	15	6110.981	2012	9
9/7/2012	16	6082.181	2012	9
9/7/2012	17	5912.681	2012	9
9/7/2012	18	5626.381	2012	9
9/7/2012	19	5552.881	2012	9
9/7/2012	20	5319.381	2012	9
9/7/2012	21	5006.68	2012	9
9/7/2012	22	4641.88	2012	9
9/7/2012	23	4122.08	2012	9
9/8/2012	0	3831.68	2012	9
9/8/2012	1	3574.08	2012	9
9/8/2012	2	3410.78	2012	9
9/8/2012	3	3325.78	2012	9
9/8/2012	4	3320.08	2012	9
9/8/2012	5	3377.38	2012	9
9/8/2012	6	3470.58	2012	9
9/8/2012	7	3461.781	2012	9
9/8/2012	8	3605.88	2012	9
9/8/2012	9	3692.581	2012	9
9/8/2012	10	3717.28	2012	9
9/8/2012	11	3778.98	2012	9
9/8/2012	12	3820.781	2012	9
9/8/2012	13	3908.911	2012	9
9/8/2012	14	3951.28	2012	9
9/8/2012	15	3990.781	2012	9
9/8/2012	16	4015.48	2012	9
9/8/2012	17	3968.881	2012	9
9/8/2012	18	3852.397	2012	9
9/8/2012	19	3807.28	2012	9
9/8/2012	20	3708.88	2012	9
9/8/2012	21	3445.78	2012	9
9/8/2012	22	3216.98	2012	9
9/8/2012	23	2984.079	2012	9
9/9/2012	0	2822.58	2012	9
9/9/2012	1	2713.08	2012	9
9/9/2012	2	2590.88	2012	9
9/9/2012	3	2549.98	2012	9
9/9/2012	4	2556.78	2012	9
9/9/2012	5	2606.068	2012	9
9/9/2012	6	2623.968	2012	9
9/9/2012	7	2792.281	2012	9
9/9/2012	8	3014.957	2012	9
9/9/2012	9	3152.38	2012	9
9/9/2012	10	3281.681	2012	9
9/9/2012	11	3473.08	2012	9
9/9/2012	12	3571.48	2012	9
9/9/2012	13	3736.481	2012	9
9/9/2012	14	3793.48	2012	9
9/9/2012	15	3938.081	2012	9
9/9/2012	16	4009.58	2012	9
9/9/2012	17	3901.981	2012	9
9/9/2012	18	3837.48	2012	9
9/9/2012	19	3909.38	2012	9
9/9/2012	20	3784.18	2012	9
9/9/2012	21	3527.08	2012	9

Day	Hr	Total	Year	Month
9/9/2012	22	3240.68	2012	9
9/9/2012	23	2985.18	2012	9
9/10/2012	0	2895.179	2012	9
9/10/2012	1	2778.381	2012	9
9/10/2012	2	2762.98	2012	9
9/10/2012	3	2778.78	2012	9
9/10/2012	4	2987.58	2012	9
9/10/2012	5	3259.38	2012	9
9/10/2012	6	3513.68	2012	9
9/10/2012	7	3680.868	2012	9
9/10/2012	8	3843.971	2012	9
9/10/2012	9	4068.178	2012	9
9/10/2012	10	4149.681	2012	9
9/10/2012	11	4225.08	2012	9
9/10/2012	12	4343.88	2012	9
9/10/2012	13	4452.581	2012	9
9/10/2012	14	4573.88	2012	9
9/10/2012	15	4674.281	2012	9
9/10/2012	16	4687.08	2012	9
9/10/2012	17	4600.081	2012	9
9/10/2012	18	4442.58	2012	9
9/10/2012	19	4460.28	2012	9
9/10/2012	20	4246.48	2012	9
9/10/2012	21	3857.08	2012	9
9/10/2012	22	3519.681	2012	9
9/10/2012	23	3224.58	2012	9
9/11/2012	0	3059.081	2012	9
9/11/2012	1	2966.28	2012	9
9/11/2012	2	2862.98	2012	9
9/11/2012	3	2826.08	2012	9
9/11/2012	4	3030.881	2012	9
9/11/2012	5	3422.98	2012	9
9/11/2012	6	3542.881	2012	9
9/11/2012	7	3702.581	2012	9
9/11/2012	8	3802.48	2012	9
9/11/2012	9	3959.798	2012	9
9/11/2012	10	4145.457	2012	9
9/11/2012	11	4291.3	2012	9
9/11/2012	12	4437.081	2012	9
9/11/2012	13	4613.28	2012	9
9/11/2012	14	4756.395	2012	9
9/11/2012	15	4842.58	2012	9
9/11/2012	16	4883.781	2012	9
9/11/2012	17	4811.78	2012	9
9/11/2012	18	4638.981	2012	9
9/11/2012	19	4643.38	2012	9
9/11/2012	20	4367.98	2012	9
9/11/2012	21	4010.08	2012	9
9/11/2012	22	3619.48	2012	9
9/11/2012	23	3434.281	2012	9
9/12/2012	0	3241.68	2012	9
9/12/2012	1	3115.48	2012	9
9/12/2012	2	3016.08	2012	9
9/12/2012	3	2989.48	2012	9
9/12/2012	4	3147.28	2012	9
9/12/2012	5	3523.48	2012	9
9/12/2012	6	3702.38	2012	9
9/12/2012	7	3791.881	2012	9
9/12/2012	8	3991.98	2012	9
9/12/2012	9	4208.781	2012	9
9/12/2012	10	4378.08	2012	9
9/12/2012	11	4637.58	2012	9
9/12/2012	12	4850.281	2012	9
9/12/2012	13	4981.88	2012	9

Day	Hr	Total	Year	Month
9/12/2012	14	5042.081	2012	9
9/12/2012	15	5107.98	2012	9
9/12/2012	16	5103.981	2012	9
9/12/2012	17	4993.281	2012	9
9/12/2012	18	4803.78	2012	9
9/12/2012	19	4821.48	2012	9
9/12/2012	20	4550.28	2012	9
9/12/2012	21	4195.179	2012	9
9/12/2012	22	3798.08	2012	9
9/12/2012	23	3573.28	2012	9
9/13/2012	0	3350.38	2012	9
9/13/2012	1	3267.28	2012	9
9/13/2012	2	3138.68	2012	9
9/13/2012	3	3097.081	2012	9
9/13/2012	4	3282.48	2012	9
9/13/2012	5	3624.075	2012	9
9/13/2012	6	3860.964	2012	9
9/13/2012	7	3988.18	2012	9
9/13/2012	8	4135.681	2012	9
9/13/2012	9	4391.281	2012	9
9/13/2012	10	4590.48	2012	9
9/13/2012	11	4803.181	2012	9
9/13/2012	12	4967.68	2012	9
9/13/2012	13	5141.681	2012	9
9/13/2012	14	5183.881	2012	9
9/13/2012	15	5213.381	2012	9
9/13/2012	16	5176.481	2012	9
9/13/2012	17	5059.481	2012	9
9/13/2012	18	4892.88	2012	9
9/13/2012	19	4908.581	2012	9
9/13/2012	20	4672.68	2012	9
9/13/2012	21	4255.179	2012	9
9/13/2012	22	3886.78	2012	9
9/13/2012	23	3605.28	2012	9
9/14/2012	0	3414.08	2012	9
9/14/2012	1	3164.18	2012	9
9/14/2012	2	3062.68	2012	9
9/14/2012	3	3001.879	2012	9
9/14/2012	4	3158.08	2012	9
9/14/2012	5	3533.081	2012	9
9/14/2012	6	3699.68	2012	9
9/14/2012	7	3759.58	2012	9
9/14/2012	8	4006.481	2012	9
9/14/2012	9	4333.48	2012	9
9/14/2012	10	4542.68	2012	9
9/14/2012	11	4738.881	2012	9
9/14/2012	12	4819.68	2012	9
9/14/2012	13	4854.381	2012	9
9/14/2012	14	4840.98	2012	9
9/14/2012	15	4684.68	2012	9
9/14/2012	16	4506.581	2012	9
9/14/2012	17	4307.28	2012	9
9/14/2012	18	4161.28	2012	9
9/14/2012	19	4194.28	2012	9
9/14/2012	20	3997.065	2012	9
9/14/2012	21	3707.972	2012	9
9/14/2012	22	3459.079	2012	9
9/14/2012	23	3188.58	2012	9
9/15/2012	0	2968.68	2012	9
9/15/2012	1	2797.28	2012	9
9/15/2012	2	2696.78	2012	9
9/15/2012	3	2684.18	2012	9
9/15/2012	4	2681.279	2012	9
9/15/2012	5	2737.08	2012	9

Day	Hr	Total	Year	Month
9/15/2012	6	2812.181	2012	9
9/15/2012	7	2981.28	2012	9
9/15/2012	8	3176.98	2012	9
9/15/2012	9	3326.581	2012	9
9/15/2012	10	3441.88	2012	9
9/15/2012	11	3520.68	2012	9
9/15/2012	12	3602.68	2012	9
9/15/2012	13	3679.171	2012	9
9/15/2012	14	3766.468	2012	9
9/15/2012	15	3843.08	2012	9
9/15/2012	16	3776.181	2012	9
9/15/2012	17	3681.18	2012	9
9/15/2012	18	3621.58	2012	9
9/15/2012	19	3704.18	2012	9
9/15/2012	20	3514.58	2012	9
9/15/2012	21	3322.78	2012	9
9/15/2012	22	3177.479	2012	9
9/15/2012	23	2898.98	2012	9
9/16/2012	0	2699.58	2012	9
9/16/2012	1	2608.78	2012	9
9/16/2012	2	2588.78	2012	9
9/16/2012	3	2568.28	2012	9
9/16/2012	4	2535.779	2012	9
9/16/2012	5	2593.481	2012	9
9/16/2012	6	2700.08	2012	9
9/16/2012	7	2781.58	2012	9
9/16/2012	8	2940.28	2012	9
9/16/2012	9	3125.181	2012	9
9/16/2012	10	3306.78	2012	9
9/16/2012	11	3442.781	2012	9
9/16/2012	12	3621.18	2012	9
9/16/2012	13	3752.68	2012	9
9/16/2012	14	3844.881	2012	9
9/16/2012	15	3972.78	2012	9
9/16/2012	16	4027.28	2012	9
9/16/2012	17	3991.281	2012	9
9/16/2012	18	3945.38	2012	9
9/16/2012	19	4085.68	2012	9
9/16/2012	20	3892.28	2012	9
9/16/2012	21	3612.58	2012	9
9/16/2012	22	3406.58	2012	9
9/16/2012	23	3142.972	2012	9
9/17/2012	0	3016.465	2012	9
9/17/2012	1	2940.68	2012	9
9/17/2012	2	2924.78	2012	9
9/17/2012	3	2932.58	2012	9
9/17/2012	4	3131.38	2012	9
9/17/2012	5	3502.08	2012	9
9/17/2012	6	3791.98	2012	9
9/17/2012	7	3918.58	2012	9
9/17/2012	8	4001.781	2012	9
9/17/2012	9	4102.38	2012	9
9/17/2012	10	4114.48	2012	9
9/17/2012	11	4158.381	2012	9
9/17/2012	12	4194.38	2012	9
9/17/2012	13	4176.58	2012	9
9/17/2012	14	4124.081	2012	9
9/17/2012	15	4071.58	2012	9
9/17/2012	16	4046.68	2012	9
9/17/2012	17	4032.081	2012	9
9/17/2012	18	4094.88	2012	9
9/17/2012	19	4205.074	2012	9
9/17/2012	20	4055.763	2012	9
9/17/2012	21	3794.28	2012	9

Day	Hr	Total	Year	Month
9/17/2012	22	3517.88	2012	9
9/17/2012	23	3339.78	2012	9
9/18/2012	0	3198.08	2012	9
9/18/2012	1	3076.88	2012	9
9/18/2012	2	3015.78	2012	9
9/18/2012	3	3028.48	2012	9
9/18/2012	4	3160.18	2012	9
9/18/2012	5	3587.379	2012	9
9/18/2012	6	3892.581	2012	9
9/18/2012	7	3933.08	2012	9
9/18/2012	8	3986.181	2012	9
9/18/2012	9	4051.48	2012	9
9/18/2012	10	4037.481	2012	9
9/18/2012	11	4033.88	2012	9
9/18/2012	12	4023.881	2012	9
9/18/2012	13	3984.38	2012	9
9/18/2012	14	3950.38	2012	9
9/18/2012	15	3884.481	2012	9
9/18/2012	16	3857.08	2012	9
9/18/2012	17	3794.68	2012	9
9/18/2012	18	3743.881	2012	9
9/18/2012	19	3901.673	2012	9
9/18/2012	20	3764.864	2012	9
9/18/2012	21	3495.08	2012	9
9/18/2012	22	3193.581	2012	9
9/18/2012	23	3006.379	2012	9
9/19/2012	0	2890.28	2012	9
9/19/2012	1	2765.28	2012	9
9/19/2012	2	2716.78	2012	9
9/19/2012	3	2729.181	2012	9
9/19/2012	4	2887.38	2012	9
9/19/2012	5	3225.68	2012	9
9/19/2012	6	3451.48	2012	9
9/19/2012	7	3560.768	2012	9
9/19/2012	8	3664.973	2012	9
9/19/2012	9	3734.48	2012	9
9/19/2012	10	3764.18	2012	9
9/19/2012	11	3795.18	2012	9
9/19/2012	12	3774.881	2012	9
9/19/2012	13	3790.961	2012	9
9/19/2012	14	3799.18	2012	9
9/19/2012	15	3821.081	2012	9
9/19/2012	16	3809.68	2012	9
9/19/2012	17	3786.68	2012	9
9/19/2012	18	3737.681	2012	9
9/19/2012	19	3874.38	2012	9
9/19/2012	20	3722.58	2012	9
9/19/2012	21	3483.28	2012	9
9/19/2012	22	3211.879	2012	9
9/19/2012	23	3004.881	2012	9
9/20/2012	0	2908.966	2012	9
9/20/2012	1	2800.272	2012	9
9/20/2012	2	2776.98	2012	9
9/20/2012	3	2749.58	2012	9
9/20/2012	4	2920.28	2012	9
9/20/2012	5	3364.48	2012	9
9/20/2012	6	3550.38	2012	9
9/20/2012	7	3598.781	2012	9
9/20/2012	8	3701.98	2012	9
9/20/2012	9	3750.18	2012	9
9/20/2012	10	3792.381	2012	9
9/20/2012	11	3884.78	2012	9
9/20/2012	12	3954.673	2012	9
9/20/2012	13	4011.068	2012	9

Day	Hr	Total	Year	Month
9/20/2012	14	4041.625	2012	9
9/20/2012	15	4062.98	2012	9
9/20/2012	16	4056.48	2012	9
9/20/2012	17	4029.881	2012	9
9/20/2012	18	3998.38	2012	9
9/20/2012	19	4160.58	2012	9
9/20/2012	20	3974.18	2012	9
9/20/2012	21	3720.88	2012	9
9/20/2012	22	3431.78	2012	9
9/20/2012	23	3165.88	2012	9
9/21/2012	0	3041.381	2012	9
9/21/2012	1	2913.28	2012	9
9/21/2012	2	2831.38	2012	9
9/21/2012	3	2829.881	2012	9
9/21/2012	4	2950.98	2012	9
9/21/2012	5	3323.981	2012	9
9/21/2012	6	3543.581	2012	9
9/21/2012	7	3542.274	2012	9
9/21/2012	8	3744.966	2012	9
9/21/2012	9	3875.781	2012	9
9/21/2012	10	3978.381	2012	9
9/21/2012	11	4080.581	2012	9
9/21/2012	12	4127.581	2012	9
9/21/2012	13	4153.781	2012	9
9/21/2012	14	4150.28	2012	9
9/21/2012	15	4162.281	2012	9
9/21/2012	16	4118.98	2012	9
9/21/2012	17	4022.381	2012	9
9/21/2012	18	3947.28	2012	9
9/21/2012	19	3986.78	2012	9
9/21/2012	20	3898.88	2012	9
9/21/2012	21	3736.08	2012	9
9/21/2012	22	3497.58	2012	9
9/21/2012	23	3259.479	2012	9
9/22/2012	0	3052.88	2012	9
9/22/2012	1	2894.08	2012	9
9/22/2012	2	2798.379	2012	9
9/22/2012	3	2727.98	2012	9
9/22/2012	4	2767.878	2012	9
9/22/2012	5	2896.364	2012	9
9/22/2012	6	2948.776	2012	9
9/22/2012	7	3107.08	2012	9
9/22/2012	8	3270.981	2012	9
9/22/2012	9	3450.68	2012	9
9/22/2012	10	3566.18	2012	9
9/22/2012	11	3615.281	2012	9
9/22/2012	12	3675.18	2012	9
9/22/2012	13	3694.28	2012	9
9/22/2012	14	3678.081	2012	9
9/22/2012	15	3715.48	2012	9
9/22/2012	16	3690.881	2012	9
9/22/2012	17	3548.38	2012	9
9/22/2012	18	3396.952	2012	9
9/22/2012	19	3413.98	2012	9
9/22/2012	20	3278.58	2012	9
9/22/2012	21	3121.08	2012	9
9/22/2012	22	2799.869	2012	9
9/22/2012	23	2692.87	2012	9
9/23/2012	0	2547.48	2012	9
9/23/2012	1	2403.28	2012	9
9/23/2012	2	2476.579	2012	9
9/23/2012	3	2395.08	2012	9
9/23/2012	4	2443.079	2012	9
9/23/2012	5	2545.78	2012	9

Day	Hr	Total	Year	Month
9/23/2012	6	2571.38	2012	9
9/23/2012	7	2790.78	2012	9
9/23/2012	8	2878.769	2012	9
9/23/2012	9	2930.772	2012	9
9/23/2012	10	2925.48	2012	9
9/23/2012	11	3024.181	2012	9
9/23/2012	12	3000.78	2012	9
9/23/2012	13	2959.78	2012	9
9/23/2012	14	3029.18	2012	9
9/23/2012	15	3044.381	2012	9
9/23/2012	16	3121.48	2012	9
9/23/2012	17	3121.081	2012	9
9/23/2012	18	3206.08	2012	9
9/23/2012	19	3286.98	2012	9
9/23/2012	20	3168.58	2012	9
9/23/2012	21	3074.28	2012	9
9/23/2012	22	2812.771	2012	9
9/23/2012	23	2718.067	2012	9
9/24/2012	0	2630.08	2012	9
9/24/2012	1	2632.28	2012	9
9/24/2012	2	2637.48	2012	9
9/24/2012	3	2703.079	2012	9
9/24/2012	4	2926.38	2012	9
9/24/2012	5	3318.176	2012	9
9/24/2012	6	3578.98	2012	9
9/24/2012	7	3659.271	2012	9
9/24/2012	8	3769.67	2012	9
9/24/2012	9	3787.181	2012	9
9/24/2012	10	3805.68	2012	9
9/24/2012	11	3788.481	2012	9
9/24/2012	12	3781.78	2012	9
9/24/2012	13	3747.68	2012	9
9/24/2012	14	3781.581	2012	9
9/24/2012	15	3755.381	2012	9
9/24/2012	16	3728.58	2012	9
9/24/2012	17	3696.381	2012	9
9/24/2012	18	3725.881	2012	9
9/24/2012	19	3853.68	2012	9
9/24/2012	20	3643.181	2012	9
9/24/2012	21	3457.671	2012	9
9/24/2012	22	3198.269	2012	9
9/24/2012	23	3016.981	2012	9
9/25/2012	0	2908.18	2012	9
9/25/2012	1	2778.68	2012	9
9/25/2012	2	2754.581	2012	9
9/25/2012	3	2766.88	2012	9
9/25/2012	4	2953.98	2012	9
9/25/2012	5	3360.28	2012	9
9/25/2012	6	3609.981	2012	9
9/25/2012	7	3717.281	2012	9
9/25/2012	8	3824.67	2012	9
9/25/2012	9	3948.471	2012	9
9/25/2012	10	3870.481	2012	9
9/25/2012	11	3908.381	2012	9
9/25/2012	12	3886.181	2012	9
9/25/2012	13	3882.064	2012	9
9/25/2012	14	3805.281	2012	9
9/25/2012	15	3778.581	2012	9
9/25/2012	16	3796.78	2012	9
9/25/2012	17	3726.381	2012	9
9/25/2012	18	3859.781	2012	9
9/25/2012	19	3943.48	2012	9
9/25/2012	20	3817.18	2012	9
9/25/2012	21	3533.365	2012	9

Day	Hr	Total	Year	Month
9/25/2012	22	3316.476	2012	9
9/25/2012	23	3109.581	2012	9
9/26/2012	0	2951.58	2012	9
9/26/2012	1	2909.28	2012	9
9/26/2012	2	2846.981	2012	9
9/26/2012	3	2886.58	2012	9
9/26/2012	4	3014.68	2012	9
9/26/2012	5	3419.281	2012	9
9/26/2012	6	3657.167	2012	9
9/26/2012	7	3723.475	2012	9
9/26/2012	8	3852.181	2012	9
9/26/2012	9	3954.381	2012	9
9/26/2012	10	3979.881	2012	9
9/26/2012	11	4102.48	2012	9
9/26/2012	12	4178.781	2012	9
9/26/2012	13	4296.481	2012	9
9/26/2012	14	4359.681	2012	9
9/26/2012	15	4343.88	2012	9
9/26/2012	16	4354.881	2012	9
9/26/2012	17	4326.381	2012	9
9/26/2012	18	4354.38	2012	9
9/26/2012	19	4425.881	2012	9
9/26/2012	20	4141.98	2012	9
9/26/2012	21	3852.1	2012	9
9/26/2012	22	3581.458	2012	9
9/26/2012	23	3305.964	2012	9
9/27/2012	0	3128.777	2012	9
9/27/2012	1	3008.38	2012	9
9/27/2012	2	2962.08	2012	9
9/27/2012	3	2975.181	2012	9
9/27/2012	4	3087.68	2012	9
9/27/2012	5	3471.2	2012	9
9/27/2012	6	3740.661	2012	9
9/27/2012	7	3789.981	2012	9
9/27/2012	8	3908.074	2012	9
9/27/2012	9	4019.268	2012	9
9/27/2012	10	4121.381	2012	9
9/27/2012	11	4196.681	2012	9
9/27/2012	12	4242.281	2012	9
9/27/2012	13	4312.181	2012	9
9/27/2012	14	4350.492	2012	9
9/27/2012	15	4383.2	2012	9
9/27/2012	16	4360.262	2012	9
9/27/2012	17	4287.681	2012	9
9/27/2012	18	4282.18	2012	9
9/27/2012	19	4362.081	2012	9
9/27/2012	20	4201.38	2012	9
9/27/2012	21	3938.881	2012	9
9/27/2012	22	3586.68	2012	9
9/27/2012	23	3404.64	2012	9
9/28/2012	0	3193.38	2012	9
9/28/2012	1	3095.381	2012	9
9/28/2012	2	3007.88	2012	9
9/28/2012	3	2958.7	2012	9
9/28/2012	4	3174.754	2012	9
9/28/2012	5	3524.481	2012	9
9/28/2012	6	3796.48	2012	9
9/28/2012	7	3855.082	2012	9
9/28/2012	8	3952.68	2012	9
9/28/2012	9	4026.381	2012	9
9/28/2012	10	4036.755	2012	9
9/28/2012	11	4081.881	2012	9
9/28/2012	12	4101.08	2012	9
9/28/2012	13	4112.981	2012	9

Day	Hr	Total	Year	Month
9/28/2012	14	4150.1	2012	9
9/28/2012	15	4121.081	2012	9
9/28/2012	16	4059.854	2012	9
9/28/2012	17	3935.781	2012	9
9/28/2012	18	3952.68	2012	9
9/28/2012	19	3937.4	2012	9
9/28/2012	20	3795.76	2012	9
9/28/2012	21	3640.881	2012	9
9/28/2012	22	3370.98	2012	9
9/28/2012	23	3139.78	2012	9
9/29/2012	0	2934.38	2012	9
9/29/2012	1	2801.178	2012	9
9/29/2012	2	2705.063	2012	9
9/29/2012	3	2682.478	2012	9
9/29/2012	4	2667.281	2012	9
9/29/2012	5	2741.58	2012	9
9/29/2012	6	2831.181	2012	9
9/29/2012	7	2930.781	2012	9
9/29/2012	8	3174.78	2012	9
9/29/2012	9	3280.381	2012	9
9/29/2012	10	3319.981	2012	9
9/29/2012	11	3328.381	2012	9
9/29/2012	12	3413.181	2012	9
9/29/2012	13	3455.881	2012	9
9/29/2012	14	3535.281	2012	9
9/29/2012	15	3570.981	2012	9
9/29/2012	16	3583.276	2012	9
9/29/2012	17	3459.664	2012	9
9/29/2012	18	3499.181	2012	9
9/29/2012	19	3492.58	2012	9
9/29/2012	20	3336.08	2012	9
9/29/2012	21	3195.981	2012	9
9/29/2012	22	2962.779	2012	9
9/29/2012	23	2786.881	2012	9
9/30/2012	0	2637.18	2012	9
9/30/2012	1	2521.681	2012	9
9/30/2012	2	2428.18	2012	9
9/30/2012	3	2487.88	2012	9
9/30/2012	4	2476.9	2012	9
9/30/2012	5	2570.858	2012	9
9/30/2012	6	2604.264	2012	9
9/30/2012	7	2699.08	2012	9
9/30/2012	8	2860.781	2012	9
9/30/2012	9	2996.181	2012	9
9/30/2012	10	3046.18	2012	9
9/30/2012	11	3170.981	2012	9
9/30/2012	12	3296.881	2012	9
9/30/2012	13	3299.881	2012	9
9/30/2012	14	3313.781	2012	9
9/30/2012	15	3380.181	2012	9
9/30/2012	16	3390.182	2012	9
9/30/2012	17	3392.381	2012	9
9/30/2012	18	3504.281	2012	9
9/30/2012	19	3574.68	2012	9
9/30/2012	20	3425.6	2012	9
9/30/2012	21	3256.36	2012	9
9/30/2012	22	3018.076	2012	9
9/30/2012	23	2864.264	2012	9
10/1/2012	0	2771.981	2012	10
10/1/2012	1	2663.08	2012	10
10/1/2012	2	2627.081	2012	10
10/1/2012	3	2696.48	2012	10
10/1/2012	4	2857.381	2012	10
10/1/2012	5	3192.78	2012	10

Day	Hr	Total	Year	Month
10/1/2012	6	3483.381	2012	10
10/1/2012	7	3575.981	2012	10
10/1/2012	8	3659.533	2012	10
10/1/2012	9	3750.771	2012	10
10/1/2012	10	3783.271	2012	10
10/1/2012	11	3791.578	2012	10
10/1/2012	12	3850.279	2012	10
10/1/2012	13	3774.78	2012	10
10/1/2012	14	3777.58	2012	10
10/1/2012	15	3718.881	2012	10
10/1/2012	16	3728.18	2012	10
10/1/2012	17	3770.668	2012	10
10/1/2012	18	3874.772	2012	10
10/1/2012	19	3828.3	2012	10
10/1/2012	20	3704.816	2012	10
10/1/2012	21	3518.48	2012	10
10/1/2012	22	3250.072	2012	10
10/1/2012	23	3113.371	2012	10
10/2/2012	0	2933.58	2012	10
10/2/2012	1	2833.781	2012	10
10/2/2012	2	2788.48	2012	10
10/2/2012	3	2786.58	2012	10
10/2/2012	4	2943.059	2012	10
10/2/2012	5	3301.576	2012	10
10/2/2012	6	3607.569	2012	10
10/2/2012	7	3675.88	2012	10
10/2/2012	8	3760.681	2012	10
10/2/2012	9	3897.081	2012	10
10/2/2012	10	3901.679	2012	10
10/2/2012	11	3994.176	2012	10
10/2/2012	12	4045.567	2012	10
10/2/2012	13	4091.763	2012	10
10/2/2012	14	4046.862	2012	10
10/2/2012	15	3996.963	2012	10
10/2/2012	16	3932.462	2012	10
10/2/2012	17	3870.663	2012	10
10/2/2012	18	4009.162	2012	10
10/2/2012	19	3991.162	2012	10
10/2/2012	20	3847.661	2012	10
10/2/2012	21	3556.262	2012	10
10/2/2012	22	3364.261	2012	10
10/2/2012	23	3153.762	2012	10
10/3/2012	0	3007.462	2012	10
10/3/2012	1	2872.961	2012	10
10/3/2012	2	2807.162	2012	10
10/3/2012	3	2835.861	2012	10
10/3/2012	4	2941.6	2012	10
10/3/2012	5	3285.023	2012	10
10/3/2012	6	3567.3	2012	10
10/3/2012	7	3564.724	2012	10
10/3/2012	8	3610.6	2012	10
10/3/2012	9	3770.423	2012	10
10/3/2012	10	3833.062	2012	10
10/3/2012	11	3901.662	2012	10
10/3/2012	12	3971.562	2012	10
10/3/2012	13	4020.812	2012	10
10/3/2012	14	4061.762	2012	10
10/3/2012	15	4049.362	2012	10
10/3/2012	16	3991.662	2012	10
10/3/2012	17	3937.062	2012	10
10/3/2012	18	3991.362	2012	10
10/3/2012	19	4025.462	2012	10
10/3/2012	20	3831.762	2012	10
10/3/2012	21	3604.1	2012	10

Day	Hr	Total	Year	Month
10/3/2012	22	3345.323	2012	10
10/3/2012	23	3131	2012	10
10/4/2012	0	2988.723	2012	10
10/4/2012	1	2876.261	2012	10
10/4/2012	2	2816.161	2012	10
10/4/2012	3	2780.862	2012	10
10/4/2012	4	2931.561	2012	10
10/4/2012	5	3277.5	2012	10
10/4/2012	6	3571.723	2012	10
10/4/2012	7	3619.762	2012	10
10/4/2012	8	3728.062	2012	10
10/4/2012	9	3852.462	2012	10
10/4/2012	10	3924.245	2012	10
10/4/2012	11	4053.749	2012	10
10/4/2012	12	4176.596	2012	10
10/4/2012	13	4248.181	2012	10
10/4/2012	14	4301.1	2012	10
10/4/2012	15	4273.361	2012	10
10/4/2012	16	4262.6	2012	10
10/4/2012	17	4157.461	2012	10
10/4/2012	18	4135.68	2012	10
10/4/2012	19	4145.081	2012	10
10/4/2012	20	3971.98	2012	10
10/4/2012	21	3667.98	2012	10
10/4/2012	22	3416.68	2012	10
10/4/2012	23	3216.581	2012	10
10/5/2012	0	3032.38	2012	10
10/5/2012	1	2927.38	2012	10
10/5/2012	2	2876.38	2012	10
10/5/2012	3	2830.68	2012	10
10/5/2012	4	2980.081	2012	10
10/5/2012	5	3258.78	2012	10
10/5/2012	6	3549.58	2012	10
10/5/2012	7	3609.281	2012	10
10/5/2012	8	3743.981	2012	10
10/5/2012	9	3896.58	2012	10
10/5/2012	10	4004.881	2012	10
10/5/2012	11	4107.98	2012	10
10/5/2012	12	4186.581	2012	10
10/5/2012	13	4223.98	2012	10
10/5/2012	14	4198.708	2012	10
10/5/2012	15	4168	2012	10
10/5/2012	16	4032.48	2012	10
10/5/2012	17	4002.581	2012	10
10/5/2012	18	4001.68	2012	10
10/5/2012	19	3944.681	2012	10
10/5/2012	20	3742.469	2012	10
10/5/2012	21	3486.866	2012	10
10/5/2012	22	3270.581	2012	10
10/5/2012	23	3025.08	2012	10
10/6/2012	0	2852.781	2012	10
10/6/2012	1	2689.28	2012	10
10/6/2012	2	2630.28	2012	10
10/6/2012	3	2625.581	2012	10
10/6/2012	4	2642.179	2012	10
10/6/2012	5	2731.18	2012	10
10/6/2012	6	2810.481	2012	10
10/6/2012	7	2916.966	2012	10
10/6/2012	8	3112.573	2012	10
10/6/2012	9	3193.081	2012	10
10/6/2012	10	3220.08	2012	10
10/6/2012	11	3186.38	2012	10
10/6/2012	12	3150.981	2012	10
10/6/2012	13	3135.08	2012	10

Day	Hr	Total	Year	Month
10/6/2012	14	3091.68	2012	10
10/6/2012	15	3073.881	2012	10
10/6/2012	16	3106.08	2012	10
10/6/2012	17	3138.181	2012	10
10/6/2012	18	3253.07	2012	10
10/6/2012	19	3321.07	2012	10
10/6/2012	20	3196.5	2012	10
10/6/2012	21	3061.06	2012	10
10/6/2012	22	2901.781	2012	10
10/6/2012	23	2703.28	2012	10
10/7/2012	0	2595.68	2012	10
10/7/2012	1	2530.5	2012	10
10/7/2012	2	2506.66	2012	10
10/7/2012	3	2560.367	2012	10
10/7/2012	4	2596.675	2012	10
10/7/2012	5	2630.66	2012	10
10/7/2012	6	2803.18	2012	10
10/7/2012	7	2884.881	2012	10
10/7/2012	8	3057.48	2012	10
10/7/2012	9	3112.581	2012	10
10/7/2012	10	3124.478	2012	10
10/7/2012	11	3144.765	2012	10
10/7/2012	12	3087.781	2012	10
10/7/2012	13	3048.481	2012	10
10/7/2012	14	3000.181	2012	10
10/7/2012	15	3027.781	2012	10
10/7/2012	16	3006.28	2012	10
10/7/2012	17	3111.081	2012	10
10/7/2012	18	3289.581	2012	10
10/7/2012	19	3407.977	2012	10
10/7/2012	20	3315.866	2012	10
10/7/2012	21	3143.68	2012	10
10/7/2012	22	3025.48	2012	10
10/7/2012	23	2881.579	2012	10
10/8/2012	0	2764.88	2012	10
10/8/2012	1	2789.2	2012	10
10/8/2012	2	2769.157	2012	10
10/8/2012	3	2823.9	2012	10
10/8/2012	4	3062.562	2012	10
10/8/2012	5	3432.458	2012	10
10/8/2012	6	3716.379	2012	10
10/8/2012	7	3832	2012	10
10/8/2012	8	3927.96	2012	10
10/8/2012	9	3970.966	2012	10
10/8/2012	10	3954.075	2012	10
10/8/2012	11	3920.38	2012	10
10/8/2012	12	3869.581	2012	10
10/8/2012	13	3839.78	2012	10
10/8/2012	14	3722.081	2012	10
10/8/2012	15	3705.28	2012	10
10/8/2012	16	3671.481	2012	10
10/8/2012	17	3672.68	2012	10
10/8/2012	18	3829.768	2012	10
10/8/2012	19	3907.375	2012	10
10/8/2012	20	3783.5	2012	10
10/8/2012	21	3582.56	2012	10
10/8/2012	22	3406.079	2012	10
10/8/2012	23	3239.2	2012	10
10/9/2012	0	3151.758	2012	10
10/9/2012	1	3069.269	2012	10
10/9/2012	2	3038.5	2012	10
10/9/2012	3	3128.848	2012	10
10/9/2012	4	3269.579	2012	10
10/9/2012	5	3703.679	2012	10

Day	Hr	Total	Year	Month
10/9/2012	6	4006.779	2012	10
10/9/2012	7	4013.372	2012	10
10/9/2012	8	4008.569	2012	10
10/9/2012	9	3936.28	2012	10
10/9/2012	10	3884.78	2012	10
10/9/2012	11	3844.881	2012	10
10/9/2012	12	3852.28	2012	10
10/9/2012	13	3746.281	2012	10
10/9/2012	14	3685.48	2012	10
10/9/2012	15	3645.781	2012	10
10/9/2012	16	3647.164	2012	10
10/9/2012	17	3636.28	2012	10
10/9/2012	18	3778.48	2012	10
10/9/2012	19	3891.88	2012	10
10/9/2012	20	3723.78	2012	10
10/9/2012	21	3456.88	2012	10
10/9/2012	22	3258.781	2012	10
10/9/2012	23	3154.58	2012	10
10/10/2012	0	3043.165	2012	10
10/10/2012	1	2912.777	2012	10
10/10/2012	2	2892.28	2012	10
10/10/2012	3	2919.98	2012	10
10/10/2012	4	3095.68	2012	10
10/10/2012	5	3454.68	2012	10
10/10/2012	6	3747.78	2012	10
10/10/2012	7	3767.7	2012	10
10/10/2012	8	3820.744	2012	10
10/10/2012	9	3803.78	2012	10
10/10/2012	10	3748.781	2012	10
10/10/2012	11	3756.581	2012	10
10/10/2012	12	3768.88	2012	10
10/10/2012	13	3737.881	2012	10
10/10/2012	14	3672.08	2012	10
10/10/2012	15	3611.081	2012	10
10/10/2012	16	3614.365	2012	10
10/10/2012	17	3542.978	2012	10
10/10/2012	18	3716.781	2012	10
10/10/2012	19	3855.78	2012	10
10/10/2012	20	3777.88	2012	10
10/10/2012	21	3562.479	2012	10
10/10/2012	22	3362.88	2012	10
10/10/2012	23	3195.872	2012	10
10/11/2012	0	3186.367	2012	10
10/11/2012	1	3089.878	2012	10
10/11/2012	2	3087.879	2012	10
10/11/2012	3	3230.778	2012	10
10/11/2012	4	3397.178	2012	10
10/11/2012	5	3873.882	2012	10
10/11/2012	6	4114.262	2012	10
10/11/2012	7	4144.578	2012	10
10/11/2012	8	4063.379	2012	10
10/11/2012	9	3992.58	2012	10
10/11/2012	10	3893.581	2012	10
10/11/2012	11	3829.78	2012	10
10/11/2012	12	3823.265	2012	10
10/11/2012	13	3723.28	2012	10
10/11/2012	14	3661.081	2012	10
10/11/2012	15	3624.581	2012	10
10/11/2012	16	3599.08	2012	10
10/11/2012	17	3612.381	2012	10
10/11/2012	18	3761.481	2012	10
10/11/2012	19	3863.28	2012	10
10/11/2012	20	3643.176	2012	10
10/11/2012	21	3444.867	2012	10

Day	Hr	Total	Year	Month
10/11/2012	22	3259.68	2012	10
10/11/2012	23	3113.179	2012	10
10/12/2012	0	3053.48	2012	10
10/12/2012	1	2977.88	2012	10
10/12/2012	2	2960.48	2012	10
10/12/2012	3	2944.779	2012	10
10/12/2012	4	3040.463	2012	10
10/12/2012	5	3443.98	2012	10
10/12/2012	6	3693.881	2012	10
10/12/2012	7	3727.691	2012	10
10/12/2012	8	3734.081	2012	10
10/12/2012	9	3792.581	2012	10
10/12/2012	10	3753.281	2012	10
10/12/2012	11	3720.172	2012	10
10/12/2012	12	3673.261	2012	10
10/12/2012	13	3664.567	2012	10
10/12/2012	14	3635.767	2012	10
10/12/2012	15	3582.667	2012	10
10/12/2012	16	3526.867	2012	10
10/12/2012	17	3511.367	2012	10
10/12/2012	18	3616.767	2012	10
10/12/2012	19	3579.067	2012	10
10/12/2012	20	3510.467	2012	10
10/12/2012	21	3354.452	2012	10
10/12/2012	22	3194.063	2012	10
10/12/2012	23	3011.267	2012	10
10/13/2012	0	2929.767	2012	10
10/13/2012	1	2807.967	2012	10
10/13/2012	2	2713.567	2012	10
10/13/2012	3	2793.766	2012	10
10/13/2012	4	2790.167	2012	10
10/13/2012	5	2928.563	2012	10
10/13/2012	6	3060.951	2012	10
10/13/2012	7	3149.968	2012	10
10/13/2012	8	3194.267	2012	10
10/13/2012	9	3239.767	2012	10
10/13/2012	10	3191.467	2012	10
10/13/2012	11	3188.568	2012	10
10/13/2012	12	3173.567	2012	10
10/13/2012	13	3155.567	2012	10
10/13/2012	14	3143.172	2012	10
10/13/2012	15	3166.973	2012	10
10/13/2012	16	3193.174	2012	10
10/13/2012	17	3175.273	2012	10
10/13/2012	18	3361.572	2012	10
10/13/2012	19	3365.521	2012	10
10/13/2012	20	3264.767	2012	10
10/13/2012	21	3114.455	2012	10
10/13/2012	22	2941.87	2012	10
10/13/2012	23	2766.97	2012	10
10/14/2012	0	2641.268	2012	10
10/14/2012	1	2521.167	2012	10
10/14/2012	2	2510.667	2012	10
10/14/2012	3	2484.567	2012	10
10/14/2012	4	2517.967	2012	10
10/14/2012	5	2580.167	2012	10
10/14/2012	6	2675.067	2012	10
10/14/2012	7	2774.767	2012	10
10/14/2012	8	2902.868	2012	10
10/14/2012	9	3037.267	2012	10
10/14/2012	10	3091.468	2012	10
10/14/2012	11	3140.367	2012	10
10/14/2012	12	3161.158	2012	10
10/14/2012	13	3171.361	2012	10

Day	Hr	Total	Year	Month
10/14/2012	14	3175.672	2012	10
10/14/2012	15	3174.272	2012	10
10/14/2012	16	3225.073	2012	10
10/14/2012	17	3268.272	2012	10
10/14/2012	18	3448.27	2012	10
10/14/2012	19	3464.868	2012	10
10/14/2012	20	3332.067	2012	10
10/14/2012	21	3149.771	2012	10
10/14/2012	22	2980.667	2012	10
10/14/2012	23	2785.367	2012	10
10/15/2012	0	2652.367	2012	10
10/15/2012	1	2630.667	2012	10
10/15/2012	2	2632.266	2012	10
10/15/2012	3	2659.851	2012	10
10/15/2012	4	2839.164	2012	10
10/15/2012	5	3206.767	2012	10
10/15/2012	6	3505.667	2012	10
10/15/2012	7	3549.868	2012	10
10/15/2012	8	3657.367	2012	10
10/15/2012	9	3718.872	2012	10
10/15/2012	10	3742.368	2012	10
10/15/2012	11	3771.373	2012	10
10/15/2012	12	3786.273	2012	10
10/15/2012	13	3803.273	2012	10
10/15/2012	14	3749.373	2012	10
10/15/2012	15	3715.373	2012	10
10/15/2012	16	3653.567	2012	10
10/15/2012	17	3641.558	2012	10
10/15/2012	18	3816.868	2012	10
10/15/2012	19	3821.267	2012	10
10/15/2012	20	3700.867	2012	10
10/15/2012	21	3433.167	2012	10
10/15/2012	22	3208.967	2012	10
10/15/2012	23	3068.167	2012	10
10/16/2012	0	2940.467	2012	10
10/16/2012	1	2910.766	2012	10
10/16/2012	2	2877.859	2012	10
10/16/2012	3	2925.355	2012	10
10/16/2012	4	3181.166	2012	10
10/16/2012	5	3548.066	2012	10
10/16/2012	6	3844.823	2012	10
10/16/2012	7	3874.267	2012	10
10/16/2012	8	3865.164	2012	10
10/16/2012	9	3839.367	2012	10
10/16/2012	10	3797.173	2012	10
10/16/2012	11	3789.964	2012	10
10/16/2012	12	3806.764	2012	10
10/16/2012	13	3811.974	2012	10
10/16/2012	14	3762.072	2012	10
10/16/2012	15	3728.373	2012	10
10/16/2012	16	3690.973	2012	10
10/16/2012	17	3624.673	2012	10
10/16/2012	18	3807.871	2012	10
10/16/2012	19	3882.771	2012	10
10/16/2012	20	3683.968	2012	10
10/16/2012	21	3460.967	2012	10
10/16/2012	22	3277.467	2012	10
10/16/2012	23	3141.667	2012	10
10/17/2012	0	3014.451	2012	10
10/17/2012	1	2902.866	2012	10
10/17/2012	2	2872.567	2012	10
10/17/2012	3	2859.668	2012	10
10/17/2012	4	3103.778	2012	10
10/17/2012	5	3509.668	2012	10

Day	Hr	Total	Year	Month
10/17/2012	6	3780.767	2012	10
10/17/2012	7	3778.868	2012	10
10/17/2012	8	3771.168	2012	10
10/17/2012	9	3806.572	2012	10
10/17/2012	10	3834.573	2012	10
10/17/2012	11	3873.374	2012	10
10/17/2012	12	3858.872	2012	10
10/17/2012	13	3859.665	2012	10
10/17/2012	14	3871.762	2012	10
10/17/2012	15	3820.172	2012	10
10/17/2012	16	3763.373	2012	10
10/17/2012	17	3748.472	2012	10
10/17/2012	18	3887.673	2012	10
10/17/2012	19	3900.571	2012	10
10/17/2012	20	3728.667	2012	10
10/17/2012	21	3528.667	2012	10
10/17/2012	22	3296.467	2012	10
10/17/2012	23	3111.967	2012	10
10/18/2012	0	2955.767	2012	10
10/18/2012	1	2892.568	2012	10
10/18/2012	2	2826.867	2012	10
10/18/2012	3	2842.167	2012	10
10/18/2012	4	3009.361	2012	10
10/18/2012	5	3402.152	2012	10
10/18/2012	6	3647.495	2012	10
10/18/2012	7	3659.067	2012	10
10/18/2012	8	3727.168	2012	10
10/18/2012	9	3780.971	2012	10
10/18/2012	10	3806.071	2012	10
10/18/2012	11	3836.07	2012	10
10/18/2012	12	3835.472	2012	10
10/18/2012	13	3801.067	2012	10
10/18/2012	14	3733.768	2012	10
10/18/2012	15	3648.167	2012	10
10/18/2012	16	3639.168	2012	10
10/18/2012	17	3692.367	2012	10
10/18/2012	18	3845.853	2012	10
10/18/2012	19	3836.266	2012	10
10/18/2012	20	3717.968	2012	10
10/18/2012	21	3500.667	2012	10
10/18/2012	22	3279.867	2012	10
10/18/2012	23	3078.967	2012	10
10/19/2012	0	2955.067	2012	10
10/19/2012	1	2871.067	2012	10
10/19/2012	2	2848.367	2012	10
10/19/2012	3	2884.768	2012	10
10/19/2012	4	3060.161	2012	10
10/19/2012	5	3442.654	2012	10
10/19/2012	6	3726.167	2012	10
10/19/2012	7	3748.968	2012	10
10/19/2012	8	3772.667	2012	10
10/19/2012	9	3809.868	2012	10
10/19/2012	10	3778.268	2012	10
10/19/2012	11	3756.867	2012	10
10/19/2012	12	3770.168	2012	10
10/19/2012	13	3772.667	2012	10
10/19/2012	14	3719.755	2012	10
10/19/2012	15	3683.76	2012	10
10/19/2012	16	3709.168	2012	10
10/19/2012	17	3736.867	2012	10
10/19/2012	18	3783.867	2012	10
10/19/2012	19	3736.667	2012	10
10/19/2012	20	3611.266	2012	10
10/19/2012	21	3462.367	2012	10

Day	Hr	Total	Year	Month
10/19/2012	22	3265.266	2012	10
10/19/2012	23	3104.873	2012	10
10/20/2012	0	3017.005	2012	10
10/20/2012	1	2913.966	2012	10
10/20/2012	2	2849.567	2012	10
10/20/2012	3	2771.066	2012	10
10/20/2012	4	2848.567	2012	10
10/20/2012	5	2986.066	2012	10
10/20/2012	6	3107.166	2012	10
10/20/2012	7	3223.253	2012	10
10/20/2012	8	3369.763	2012	10
10/20/2012	9	3400.168	2012	10
10/20/2012	10	3369.467	2012	10
10/20/2012	11	3319.267	2012	10
10/20/2012	12	3287.768	2012	10
10/20/2012	13	3267.467	2012	10
10/20/2012	14	3180.668	2012	10
10/20/2012	15	3221.367	2012	10
10/20/2012	16	3163.459	2012	10
10/20/2012	17	3181.058	2012	10
10/20/2012	18	3304.067	2012	10
10/20/2012	19	3308.967	2012	10
10/20/2012	20	3257.667	2012	10
10/20/2012	21	3105.767	2012	10
10/20/2012	22	2944.967	2012	10
10/20/2012	23	2829.666	2012	10
10/21/2012	0	2753.548	2012	10
10/21/2012	1	2698.851	2012	10
10/21/2012	2	2673.162	2012	10
10/21/2012	3	2674.166	2012	10
10/21/2012	4	2724.566	2012	10
10/21/2012	5	2814.065	2012	10
10/21/2012	6	2942.666	2012	10
10/21/2012	7	3041.666	2012	10
10/21/2012	8	3101.353	2012	10
10/21/2012	9	3057.164	2012	10
10/21/2012	10	3019.368	2012	10
10/21/2012	11	2982.873	2012	10
10/21/2012	12	2985.273	2012	10
10/21/2012	13	2966.473	2012	10
10/21/2012	14	2942.174	2012	10
10/21/2012	15	2986.074	2012	10
10/21/2012	16	3038.773	2012	10
10/21/2012	17	3080.274	2012	10
10/21/2012	18	3316.372	2012	10
10/21/2012	19	3316.17	2012	10
10/21/2012	20	3200.47	2012	10
10/21/2012	21	3004.955	2012	10
10/21/2012	22	2829.46	2012	10
10/21/2012	23	2701.067	2012	10
10/22/2012	0	2603.268	2012	10
10/22/2012	1	2562.167	2012	10
10/22/2012	2	2564.867	2012	10
10/22/2012	3	2645.168	2012	10
10/22/2012	4	2824.967	2012	10
10/22/2012	5	3231.767	2012	10
10/22/2012	6	3577.869	2012	10
10/22/2012	7	3638.67	2012	10
10/22/2012	8	3684.77	2012	10
10/22/2012	9	3763.553	2012	10
10/22/2012	10	3739.671	2012	10
10/22/2012	11	3788.674	2012	10
10/22/2012	12	3805.274	2012	10
10/22/2012	13	3828.08	2012	10

Day	Hr	Total	Year	Month
10/22/2012	14	3843.38	2012	10
10/22/2012	15	3821.68	2012	10
10/22/2012	16	3784.08	2012	10
10/22/2012	17	3772.379	2012	10
10/22/2012	18	3933.875	2012	10
10/22/2012	19	3909.073	2012	10
10/22/2012	20	3718.174	2012	10
10/22/2012	21	3461.271	2012	10
10/22/2012	22	3226.772	2012	10
10/22/2012	23	3028.572	2012	10
10/23/2012	0	2874.373	2012	10
10/23/2012	1	2770.272	2012	10
10/23/2012	2	2702.072	2012	10
10/23/2012	3	2698.37	2012	10
10/23/2012	4	2859.756	2012	10
10/23/2012	5	3253.766	2012	10
10/23/2012	6	3591.768	2012	10
10/23/2012	7	3602.768	2012	10
10/23/2012	8	3674.173	2012	10
10/23/2012	9	3749.973	2012	10
10/23/2012	10	3805.674	2012	10
10/23/2012	11	3901.778	2012	10
10/23/2012	12	3979.878	2012	10
10/23/2012	13	4019.579	2012	10
10/23/2012	14	4025.379	2012	10
10/23/2012	15	3990.68	2012	10
10/23/2012	16	3930.279	2012	10
10/23/2012	17	3894.378	2012	10
10/23/2012	18	4059.174	2012	10
10/23/2012	19	3985.077	2012	10
10/23/2012	20	3815.274	2012	10
10/23/2012	21	3538.572	2012	10
10/23/2012	22	3292.874	2012	10
10/23/2012	23	3090.572	2012	10
10/24/2012	0	2932.673	2012	10
10/24/2012	1	2823.973	2012	10
10/24/2012	2	2730.266	2012	10
10/24/2012	3	2744.357	2012	10
10/24/2012	4	2907.172	2012	10
10/24/2012	5	3286.172	2012	10
10/24/2012	6	3591.37	2012	10
10/24/2012	7	3591.871	2012	10
10/24/2012	8	3687.173	2012	10
10/24/2012	9	3772.274	2012	10
10/24/2012	10	3859.68	2012	10
10/24/2012	11	3957.58	2012	10
10/24/2012	12	4064.481	2012	10
10/24/2012	13	4131.28	2012	10
10/24/2012	14	4175.779	2012	10
10/24/2012	15	4179.281	2012	10
10/24/2012	16	4135.279	2012	10
10/24/2012	17	4045.779	2012	10
10/24/2012	18	4136.978	2012	10
10/24/2012	19	4040.575	2012	10
10/24/2012	20	3827.072	2012	10
10/24/2012	21	3514.772	2012	10
10/24/2012	22	3233.572	2012	10
10/24/2012	23	3023.07	2012	10
10/25/2012	0	2870.462	2012	10
10/25/2012	1	2759.755	2012	10
10/25/2012	2	2691.566	2012	10
10/25/2012	3	2702.066	2012	10
10/25/2012	4	2855.367	2012	10
10/25/2012	5	3256.467	2012	10

Day	Hr	Total	Year	Month
10/25/2012	6	3569.867	2012	10
10/25/2012	7	3577.067	2012	10
10/25/2012	8	3660.673	2012	10
10/25/2012	9	3742.773	2012	10
10/25/2012	10	3810.974	2012	10
10/25/2012	11	3906.179	2012	10
10/25/2012	12	4018.677	2012	10
10/25/2012	13	4054.479	2012	10
10/25/2012	14	4087.079	2012	10
10/25/2012	15	4076.279	2012	10
10/25/2012	16	4043.374	2012	10
10/25/2012	17	3939.678	2012	10
10/25/2012	18	4071.474	2012	10
10/25/2012	19	3985.077	2012	10
10/25/2012	20	3813.673	2012	10
10/25/2012	21	3557.071	2012	10
10/25/2012	22	3265.856	2012	10
10/25/2012	23	3045.97	2012	10
10/26/2012	0	2894.673	2012	10
10/26/2012	1	2787.272	2012	10
10/26/2012	2	2736.173	2012	10
10/26/2012	3	2723.77	2012	10
10/26/2012	4	2880.168	2012	10
10/26/2012	5	3233.667	2012	10
10/26/2012	6	3530.467	2012	10
10/26/2012	7	3597.466	2012	10
10/26/2012	8	3663.353	2012	10
10/26/2012	9	3705.537	2012	10
10/26/2012	10	3754.838	2012	10
10/26/2012	11	3725.234	2012	10
10/26/2012	12	3795.534	2012	10
10/26/2012	13	3759.233	2012	10
10/26/2012	14	3697.233	2012	10
10/26/2012	15	3695.814	2012	10
10/26/2012	16	3632.112	2012	10
10/26/2012	17	3684.933	2012	10
10/26/2012	18	3702.832	2012	10
10/26/2012	19	3681.839	2012	10
10/26/2012	20	3562.249	2012	10
10/26/2012	21	3416.648	2012	10
10/26/2012	22	3230.332	2012	10
10/26/2012	23	3013.832	2012	10
10/27/2012	0	2908.432	2012	10
10/27/2012	1	2793.148	2012	10
10/27/2012	2	2771.548	2012	10
10/27/2012	3	2785.045	2012	10
10/27/2012	4	2805.031	2012	10
10/27/2012	5	2956.231	2012	10
10/27/2012	6	3088.73	2012	10
10/27/2012	7	3281.447	2012	10
10/27/2012	8	3379.841	2012	10
10/27/2012	9	3456.931	2012	10
10/27/2012	10	3494.031	2012	10
10/27/2012	11	3469.032	2012	10
10/27/2012	12	3399.036	2012	10
10/27/2012	13	3319.048	2012	10
10/27/2012	14	3316.749	2012	10
10/27/2012	15	3285.355	2012	10
10/27/2012	16	3246.657	2012	10
10/27/2012	17	3326.25	2012	10
10/27/2012	18	3472.766	2012	10
10/27/2012	19	3425.266	2012	10
10/27/2012	20	3338.666	2012	10
10/27/2012	21	3148.267	2012	10

Day	Hr	Total	Year	Month
10/27/2012	22	3077.466	2012	10
10/27/2012	23	2918.442	2012	10
10/28/2012	0	2831.86	2012	10
10/28/2012	1	2734.951	2012	10
10/28/2012	2	2687.866	2012	10
10/28/2012	3	2706.766	2012	10
10/28/2012	4	2701.865	2012	10
10/28/2012	5	2836.855	2012	10
10/28/2012	6	3007.444	2012	10
10/28/2012	7	3103.549	2012	10
10/28/2012	8	3209.364	2012	10
10/28/2012	9	3295.856	2012	10
10/28/2012	10	3296.752	2012	10
10/28/2012	11	3283.755	2012	10
10/28/2012	12	3292.247	2012	10
10/28/2012	13	3341.15	2012	10
10/28/2012	14	3284.954	2012	10
10/28/2012	15	3307.653	2012	10
10/28/2012	16	3371.958	2012	10
10/28/2012	17	3462.347	2012	10
10/28/2012	18	3641.545	2012	10
10/28/2012	19	3650.786	2012	10
10/28/2012	20	3514.029	2012	10
10/28/2012	21	3394.438	2012	10
10/28/2012	22	3202.246	2012	10
10/28/2012	23	3107.245	2012	10
10/29/2012	0	3060.936	2012	10
10/29/2012	1	3011.229	2012	10
10/29/2012	2	3033.444	2012	10
10/29/2012	3	3109.244	2012	10
10/29/2012	4	3393.544	2012	10
10/29/2012	5	3798.644	2012	10
10/29/2012	6	4206.528	2012	10
10/29/2012	7	4192.633	2012	10
10/29/2012	8	4268.112	2012	10
10/29/2012	9	4261.345	2012	10
10/29/2012	10	4201.533	2012	10
10/29/2012	11	4179.929	2012	10
10/29/2012	12	4147.539	2012	10
10/29/2012	13	4118.548	2012	10
10/29/2012	14	4027.032	2012	10
10/29/2012	15	4006.33	2012	10
10/29/2012	16	4043.331	2012	10
10/29/2012	17	4180.685	2012	10
10/29/2012	18	4313.147	2012	10
10/29/2012	19	4264.541	2012	10
10/29/2012	20	4176.63	2012	10
10/29/2012	21	3919.329	2012	10
10/29/2012	22	3706.545	2012	10
10/29/2012	23	3559.945	2012	10
10/30/2012	0	3429.545	2012	10
10/30/2012	1	3397.73	2012	10
10/30/2012	2	3317.635	2012	10
10/30/2012	3	3392.347	2012	10
10/30/2012	4	3596.241	2012	10
10/30/2012	5	3962.83	2012	10
10/30/2012	6	4256.336	2012	10
10/30/2012	7	4281.347	2012	10
10/30/2012	8	4344.747	2012	10
10/30/2012	9	4363.23	2012	10
10/30/2012	10	4398.936	2012	10
10/30/2012	11	4377.648	2012	10
10/30/2012	12	4337.146	2012	10
10/30/2012	13	4330.334	2012	10

Day	Hr	Total	Year	Month
10/30/2012	14	4262.93	2012	10
10/30/2012	15	4289.94	2012	10
10/30/2012	16	4245.447	2012	10
10/30/2012	17	4381.34	2012	10
10/30/2012	18	4498.93	2012	10
10/30/2012	19	4421.537	2012	10
10/30/2012	20	4293.545	2012	10
10/30/2012	21	4004.346	2012	10
10/30/2012	22	3834.246	2012	10
10/30/2012	23	3660.946	2012	10
10/31/2012	0	3495.646	2012	10
10/31/2012	1	3400.744	2012	10
10/31/2012	2	3444.328	2012	10
10/31/2012	3	3444.536	2012	10
10/31/2012	4	3623.544	2012	10
10/31/2012	5	4039.445	2012	10
10/31/2012	6	4307.234	2012	10
10/31/2012	7	4324.528	2012	10
10/31/2012	8	4291.038	2012	10
10/31/2012	9	4274.345	2012	10
10/31/2012	10	4178.847	2012	10
10/31/2012	11	4142.546	2012	10
10/31/2012	12	4095.148	2012	10
10/31/2012	13	4020.069	2012	10
10/31/2012	14	3911.876	2012	10
10/31/2012	15	3877.573	2012	10
10/31/2012	16	3839.862	2012	10
10/31/2012	17	3882.706	2012	10
10/31/2012	18	4025.751	2012	10
10/31/2012	19	4145.5	2012	10
10/31/2012	20	4057.493	2012	10
10/31/2012	21	3855.943	2012	10
10/31/2012	22	3657.345	2012	10
10/31/2012	23	3508.943	2012	10
11/1/2012	0	3409.743	2012	11
11/1/2012	1	3342.042	2012	11
11/1/2012	2	3329.041	2012	11
11/1/2012	3	3336.841	2012	11
11/1/2012	4	3617.341	2012	11
11/1/2012	5	3996.3	2012	11
11/1/2012	6	4285.054	2012	11
11/1/2012	7	4298.838	2012	11
11/1/2012	8	4233.142	2012	11
11/1/2012	9	4178.734	2012	11
11/1/2012	10	4075.531	2012	11
11/1/2012	11	4007.146	2012	11
11/1/2012	12	3978.745	2012	11
11/1/2012	13	3859.147	2012	11
11/1/2012	14	3787.246	2012	11
11/1/2012	15	3732.547	2012	11
11/1/2012	16	3714.246	2012	11
11/1/2012	17	3849.646	2012	11
11/1/2012	18	4084.445	2012	11
11/1/2012	19	4025.845	2012	11
11/1/2012	20	3974.244	2012	11
11/1/2012	21	3739.345	2012	11
11/1/2012	22	3519.944	2012	11
11/1/2012	23	3373.544	2012	11
11/2/2012	0	3228.044	2012	11
11/2/2012	1	3207.845	2012	11
11/2/2012	2	3110.944	2012	11
11/2/2012	3	3133.444	2012	11
11/2/2012	4	3340.944	2012	11
11/2/2012	5	3730.345	2012	11

Day	Hr	Total	Year	Month
11/2/2012	6	3986.344	2012	11
11/2/2012	7	4012.338	2012	11
11/2/2012	8	3975.428	2012	11
11/2/2012	9	3916.429	2012	11
11/2/2012	10	3870.146	2012	11
11/2/2012	11	3814.706	2012	11
11/2/2012	12	3779.847	2012	11
11/2/2012	13	3689.847	2012	11
11/2/2012	14	3617.446	2012	11
11/2/2012	15	3558.547	2012	11
11/2/2012	16	3552.647	2012	11
11/2/2012	17	3659.246	2012	11
11/2/2012	18	3810.446	2012	11
11/2/2012	19	3842.045	2012	11
11/2/2012	20	3752.372	2012	11
11/2/2012	21	3631.744	2012	11
11/2/2012	22	3542.54	2012	11
11/2/2012	23	3371.726	2012	11
11/3/2012	0	3252.334	2012	11
11/3/2012	1	3279.542	2012	11
11/3/2012	2	3217.336	2012	11
11/3/2012	3	3251.226	2012	11
11/3/2012	4	3378.925	2012	11
11/3/2012	5	3507.832	2012	11
11/3/2012	6	3733.342	2012	11
11/3/2012	7	3833.527	2012	11
11/3/2012	8	3820.027	2012	11
11/3/2012	9	3850.646	2012	11
11/3/2012	10	3801.726	2012	11
11/3/2012	11	3716.539	2012	11
11/3/2012	12	3597.945	2012	11
11/3/2012	13	3476.04	2012	11
11/3/2012	14	3388.229	2012	11
11/3/2012	15	3401.228	2012	11
11/3/2012	16	3476.726	2012	11
11/3/2012	17	3605.127	2012	11
11/3/2012	18	3672.326	2012	11
11/3/2012	19	3638.026	2012	11
11/3/2012	20	3595.426	2012	11
11/3/2012	21	3425.526	2012	11
11/3/2012	22	3298.026	2012	11
11/3/2012	23	3118.126	2012	11
11/4/2012	0	2992.625	2012	11
11/4/2012	1	2955.626	2012	11
11/4/2012	2	2906.825	2012	11
11/4/2012	3	2885.926	2012	11
11/4/2012	4	3011.125	2012	11
11/4/2012	5	3138.025	2012	11
11/4/2012	6	3241.225	2012	11
11/4/2012	7	3349.825	2012	11
11/4/2012	8	3462.926	2012	11
11/4/2012	9	3475.932	2012	11
11/4/2012	10	3438.045	2012	11
11/4/2012	11	3339.145	2012	11
11/4/2012	12	3279.842	2012	11
11/4/2012	13	3204.646	2012	11
11/4/2012	14	3190.547	2012	11
11/4/2012	15	3162.646	2012	11
11/4/2012	16	3163.943	2012	11
11/4/2012	17	3412.63	2012	11
11/4/2012	18	3647.44	2012	11
11/4/2012	19	3683.74	2012	11
11/4/2012	20	3639.427	2012	11
11/4/2012	21	3618.627	2012	11

Day	Hr	Total	Year	Month
11/4/2012	22	3471.405	2012	11
11/4/2012	23	3316.997	2012	11
11/5/2012	0	3278.041	2012	11
11/5/2012	1	3306.324	2012	11
11/5/2012	2	3367.924	2012	11
11/5/2012	3	3450.124	2012	11
11/5/2012	4	3561.324	2012	11
11/5/2012	5	3827.823	2012	11
11/5/2012	6	4205.724	2012	11
11/5/2012	7	4449.024	2012	11
11/5/2012	8	4474.824	2012	11
11/5/2012	9	4349.531	2012	11
11/5/2012	10	4257.143	2012	11
11/5/2012	11	4105.438	2012	11
11/5/2012	12	4042.828	2012	11
11/5/2012	13	4010.538	2012	11
11/5/2012	14	3918.944	2012	11
11/5/2012	15	3858.746	2012	11
11/5/2012	16	3870.546	2012	11
11/5/2012	17	3987.441	2012	11
11/5/2012	18	4227.027	2012	11
11/5/2012	19	4222.238	2012	11
11/5/2012	20	4138.244	2012	11
11/5/2012	21	4053.118	2012	11
11/5/2012	22	3853.627	2012	11
11/5/2012	23	3668.495	2012	11
11/6/2012	0	3588.029	2012	11
11/6/2012	1	3472.144	2012	11
11/6/2012	2	3426.032	2012	11
11/6/2012	3	3470.826	2012	11
11/6/2012	4	3507.725	2012	11
11/6/2012	5	3692.726	2012	11
11/6/2012	6	4002.524	2012	11
11/6/2012	7	4177.434	2012	11
11/6/2012	8	4233.243	2012	11
11/6/2012	9	4168.127	2012	11
11/6/2012	10	4087.734	2012	11
11/6/2012	11	3952.645	2012	11
11/6/2012	12	3947.547	2012	11
11/6/2012	13	3904.746	2012	11
11/6/2012	14	3857.246	2012	11
11/6/2012	15	3806.046	2012	11
11/6/2012	16	3827.046	2012	11
11/6/2012	17	3974.345	2012	11
11/6/2012	18	4154.245	2012	11
11/6/2012	19	4100.744	2012	11
11/6/2012	20	4046.643	2012	11
11/6/2012	21	3908.144	2012	11
11/6/2012	22	3731.826	2012	11
11/6/2012	23	3513.527	2012	11
11/7/2012	0	3376.843	2012	11
11/7/2012	1	3285.143	2012	11
11/7/2012	2	3188.335	2012	11
11/7/2012	3	3172.426	2012	11
11/7/2012	4	3250.139	2012	11
11/7/2012	5	3462.643	2012	11
11/7/2012	6	3838.443	2012	11
11/7/2012	7	4058.426	2012	11
11/7/2012	8	4088.928	2012	11
11/7/2012	9	4139.143	2012	11
11/7/2012	10	4139.141	2012	11
11/7/2012	11	4114.727	2012	11
11/7/2012	12	4121.629	2012	11
11/7/2012	13	4087.437	2012	11

Day	Hr	Total	Year	Month
11/7/2012	14	4061.245	2012	11
11/7/2012	15	3948.545	2012	11
11/7/2012	16	3983.145	2012	11
11/7/2012	17	4128.244	2012	11
11/7/2012	18	4309.943	2012	11
11/7/2012	19	4249.944	2012	11
11/7/2012	20	4193.679	2012	11
11/7/2012	21	4063.526	2012	11
11/7/2012	22	3901.94	2012	11
11/7/2012	23	3752.543	2012	11
11/8/2012	0	3604.842	2012	11
11/8/2012	1	3542.026	2012	11
11/8/2012	2	3546.925	2012	11
11/8/2012	3	3550.836	2012	11
11/8/2012	4	3635.438	2012	11
11/8/2012	5	3892.224	2012	11
11/8/2012	6	4285.6	2012	11
11/8/2012	7	4510.148	2012	11
11/8/2012	8	4469.525	2012	11
11/8/2012	9	4327.126	2012	11
11/8/2012	10	4211.188	2012	11
11/8/2012	11	4061.845	2012	11
11/8/2012	12	4018.046	2012	11
11/8/2012	13	3936.246	2012	11
11/8/2012	14	3856.246	2012	11
11/8/2012	15	3755.046	2012	11
11/8/2012	16	3739.846	2012	11
11/8/2012	17	3942.745	2012	11
11/8/2012	18	4199.944	2012	11
11/8/2012	19	4199.743	2012	11
11/8/2012	20	4204.035	2012	11
11/8/2012	21	4119.226	2012	11
11/8/2012	22	3944.432	2012	11
11/8/2012	23	3798.18	2012	11
11/9/2012	0	3660.628	2012	11
11/9/2012	1	3618.724	2012	11
11/9/2012	2	3616.624	2012	11
11/9/2012	3	3609.824	2012	11
11/9/2012	4	3678.624	2012	11
11/9/2012	5	3890.337	2012	11
11/9/2012	6	4281.331	2012	11
11/9/2012	7	4443.123	2012	11
11/9/2012	8	4401.223	2012	11
11/9/2012	9	4216.929	2012	11
11/9/2012	10	4064.644	2012	11
11/9/2012	11	3913.645	2012	11
11/9/2012	12	3867.946	2012	11
11/9/2012	13	3745.646	2012	11
11/9/2012	14	3689.646	2012	11
11/9/2012	15	3621.747	2012	11
11/9/2012	16	3512.046	2012	11
11/9/2012	17	3673.846	2012	11
11/9/2012	18	3854.146	2012	11
11/9/2012	19	3822.945	2012	11
11/9/2012	20	3768.245	2012	11
11/9/2012	21	3671.645	2012	11
11/9/2012	22	3513.244	2012	11
11/9/2012	23	3350.045	2012	11
11/10/2012	0	3156.745	2012	11
11/10/2012	1	3072.345	2012	11
11/10/2012	2	3017.345	2012	11
11/10/2012	3	2969.443	2012	11
11/10/2012	4	2990.143	2012	11
11/10/2012	5	3114.144	2012	11

Day	Hr	Total	Year	Month
11/10/2012	6	3220.242	2012	11
11/10/2012	7	3337.832	2012	11
11/10/2012	8	3384.133	2012	11
11/10/2012	9	3391.345	2012	11
11/10/2012	10	3359.446	2012	11
11/10/2012	11	3308.846	2012	11
11/10/2012	12	3245.945	2012	11
11/10/2012	13	3178.846	2012	11
11/10/2012	14	3146.645	2012	11
11/10/2012	15	3096.845	2012	11
11/10/2012	16	3154.646	2012	11
11/10/2012	17	3216.145	2012	11
11/10/2012	18	3395.346	2012	11
11/10/2012	19	3363.361	2012	11
11/10/2012	20	3302.379	2012	11
11/10/2012	21	3197.346	2012	11
11/10/2012	22	3070.546	2012	11
11/10/2012	23	2862.746	2012	11
11/11/2012	0	2733.846	2012	11
11/11/2012	1	2631.945	2012	11
11/11/2012	2	2618.445	2012	11
11/11/2012	3	2638.645	2012	11
11/11/2012	4	2663.145	2012	11
11/11/2012	5	2738.845	2012	11
11/11/2012	6	2877.444	2012	11
11/11/2012	7	2934.445	2012	11
11/11/2012	8	3033.746	2012	11
11/11/2012	9	3080.946	2012	11
11/11/2012	10	3102.647	2012	11
11/11/2012	11	3070.046	2012	11
11/11/2012	12	3070.946	2012	11
11/11/2012	13	3047.046	2012	11
11/11/2012	14	2989.446	2012	11
11/11/2012	15	2974.946	2012	11
11/11/2012	16	3006.447	2012	11
11/11/2012	17	3171.146	2012	11
11/11/2012	18	3330.348	2012	11
11/11/2012	19	3374.347	2012	11
11/11/2012	20	3334.747	2012	11
11/11/2012	21	3166.546	2012	11
11/11/2012	22	3031.946	2012	11
11/11/2012	23	2848.347	2012	11
11/12/2012	0	2708.346	2012	11
11/12/2012	1	2625.247	2012	11
11/12/2012	2	2614.345	2012	11
11/12/2012	3	2620.146	2012	11
11/12/2012	4	2676.946	2012	11
11/12/2012	5	2877.246	2012	11
11/12/2012	6	3252.745	2012	11
11/12/2012	7	3547.945	2012	11
11/12/2012	8	3612.537	2012	11
11/12/2012	9	3716.727	2012	11
11/12/2012	10	3811.127	2012	11
11/12/2012	11	3806.735	2012	11
11/12/2012	12	3883.939	2012	11
11/12/2012	13	3895.326	2012	11
11/12/2012	14	3837.328	2012	11
11/12/2012	15	3826.627	2012	11
11/12/2012	16	3841.431	2012	11
11/12/2012	17	4021.642	2012	11
11/12/2012	18	4256.937	2012	11
11/12/2012	19	4313.323	2012	11
11/12/2012	20	4253.123	2012	11
11/12/2012	21	4185.922	2012	11

Day	Hr	Total	Year	Month
11/12/2012	22	4013.435	2012	11
11/12/2012	23	3870.231	2012	11
11/13/2012	0	3731.618	2012	11
11/13/2012	1	3699.018	2012	11
11/13/2012	2	3673.418	2012	11
11/13/2012	3	3706.618	2012	11
11/13/2012	4	3795.417	2012	11
11/13/2012	5	4021.719	2012	11
11/13/2012	6	4466.517	2012	11
11/13/2012	7	4683.418	2012	11
11/13/2012	8	4646.619	2012	11
11/13/2012	9	4471.221	2012	11
11/13/2012	10	4329.234	2012	11
11/13/2012	11	4148.743	2012	11
11/13/2012	12	4076.941	2012	11
11/13/2012	13	4037.529	2012	11
11/13/2012	14	3965.939	2012	11
11/13/2012	15	3874.245	2012	11
11/13/2012	16	3870.241	2012	11
11/13/2012	17	4069.626	2012	11
11/13/2012	18	4380.025	2012	11
11/13/2012	19	4412.339	2012	11
11/13/2012	20	4410.33	2012	11
11/13/2012	21	4360.321	2012	11
11/13/2012	22	4157.619	2012	11
11/13/2012	23	3999.319	2012	11
11/14/2012	0	3895.219	2012	11
11/14/2012	1	3800.018	2012	11
11/14/2012	2	3794.417	2012	11
11/14/2012	3	3747.619	2012	11
11/14/2012	4	3854.818	2012	11
11/14/2012	5	4086.517	2012	11
11/14/2012	6	4518.718	2012	11
11/14/2012	7	4689.819	2012	11
11/14/2012	8	4688.918	2012	11
11/14/2012	9	4533.819	2012	11
11/14/2012	10	4402.324	2012	11
11/14/2012	11	4245.826	2012	11
11/14/2012	12	4160.827	2012	11
11/14/2012	13	4105.137	2012	11
11/14/2012	14	4061.145	2012	11
11/14/2012	15	4001.638	2012	11
11/14/2012	16	4035.228	2012	11
11/14/2012	17	4294.827	2012	11
11/14/2012	18	4456.425	2012	11
11/14/2012	19	4450.736	2012	11
11/14/2012	20	4382.641	2012	11
11/14/2012	21	4316.4	2012	11
11/14/2012	22	4137.921	2012	11
11/14/2012	23	3943.21	2012	11
11/15/2012	0	3814.12	2012	11
11/15/2012	1	3777.42	2012	11
11/15/2012	2	3784.119	2012	11
11/15/2012	3	3783.119	2012	11
11/15/2012	4	3862.319	2012	11
11/15/2012	5	4105.218	2012	11
11/15/2012	6	4554.218	2012	11
11/15/2012	7	4734.319	2012	11
11/15/2012	8	4612.519	2012	11
11/15/2012	9	4438.822	2012	11
11/15/2012	10	4252.545	2012	11
11/15/2012	11	4113.559	2012	11
11/15/2012	12	4017.863	2012	11
11/15/2012	13	3953.765	2012	11

Day	Hr	Total	Year	Month
11/15/2012	14	3901.964	2012	11
11/15/2012	15	3783.865	2012	11
11/15/2012	16	3779.663	2012	11
11/15/2012	17	4055.548	2012	11
11/15/2012	18	4271.355	2012	11
11/15/2012	19	4297.96	2012	11
11/15/2012	20	4245.956	2012	11
11/15/2012	21	4230.356	2012	11
11/15/2012	22	4051.539	2012	11
11/15/2012	23	3893.85	2012	11
11/16/2012	0	3816.853	2012	11
11/16/2012	1	3745.454	2012	11
11/16/2012	2	3726.844	2012	11
11/16/2012	3	3725.844	2012	11
11/16/2012	4	3792.854	2012	11
11/16/2012	5	4019.253	2012	11
11/16/2012	6	4439.442	2012	11
11/16/2012	7	4655.347	2012	11
11/16/2012	8	4588.041	2012	11
11/16/2012	9	4436.62	2012	11
11/16/2012	10	4277.221	2012	11
11/16/2012	11	4096.823	2012	11
11/16/2012	12	4001.223	2012	11
11/16/2012	13	3893.525	2012	11
11/16/2012	14	3805.136	2012	11
11/16/2012	15	3726.341	2012	11
11/16/2012	16	3745.233	2012	11
11/16/2012	17	3876.623	2012	11
11/16/2012	18	4024.137	2012	11
11/16/2012	19	4027.537	2012	11
11/16/2012	20	4045.536	2012	11
11/16/2012	21	4007.021	2012	11
11/16/2012	22	3915.92	2012	11
11/16/2012	23	3733.42	2012	11
11/17/2012	0	3647.135	2012	11
11/17/2012	1	3588.931	2012	11
11/17/2012	2	3533.819	2012	11
11/17/2012	3	3579.619	2012	11
11/17/2012	4	3588.819	2012	11
11/17/2012	5	3717.718	2012	11
11/17/2012	6	3865.125	2012	11
11/17/2012	7	3981.335	2012	11
11/17/2012	8	4073.22	2012	11
11/17/2012	9	3935.122	2012	11
11/17/2012	10	3825.525	2012	11
11/17/2012	11	3697.54	2012	11
11/17/2012	12	3568.541	2012	11
11/17/2012	13	3420.842	2012	11
11/17/2012	14	3321.042	2012	11
11/17/2012	15	3272.642	2012	11
11/17/2012	16	3258.142	2012	11
11/17/2012	17	3388.341	2012	11
11/17/2012	18	3653.44	2012	11
11/17/2012	19	3677.339	2012	11
11/17/2012	20	3675.236	2012	11
11/17/2012	21	3614.622	2012	11
11/17/2012	22	3479.023	2012	11
11/17/2012	23	3405.353	2012	11
11/18/2012	0	3319.338	2012	11
11/18/2012	1	3252.019	2012	11
11/18/2012	2	3230.319	2012	11
11/18/2012	3	3232.219	2012	11
11/18/2012	4	3254.33	2012	11
11/18/2012	5	3384.93	2012	11

Day	Hr	Total	Year	Month
11/18/2012	6	3517.719	2012	11
11/18/2012	7	3632.218	2012	11
11/18/2012	8	3689.32	2012	11
11/18/2012	9	3569.026	2012	11
11/18/2012	10	3472.64	2012	11
11/18/2012	11	3341.641	2012	11
11/18/2012	12	3180.242	2012	11
11/18/2012	13	3179.443	2012	11
11/18/2012	14	3163.342	2012	11
11/18/2012	15	3073.396	2012	11
11/18/2012	16	3162.442	2012	11
11/18/2012	17	3376.242	2012	11
11/18/2012	18	3613.541	2012	11
11/18/2012	19	3646.84	2012	11
11/18/2012	20	3678.438	2012	11
11/18/2012	21	3570.138	2012	11
11/18/2012	22	3452.637	2012	11
11/18/2012	23	3340.024	2012	11
11/19/2012	0	3264.119	2012	11
11/19/2012	1	3213.623	2012	11
11/19/2012	2	3233.139	2012	11
11/19/2012	3	3281.222	2012	11
11/19/2012	4	3441.019	2012	11
11/19/2012	5	3718.118	2012	11
11/19/2012	6	4172.019	2012	11
11/19/2012	7	4457.719	2012	11
11/19/2012	8	4402.532	2012	11
11/19/2012	9	4295.837	2012	11
11/19/2012	10	4174.033	2012	11
11/19/2012	11	4008.227	2012	11
11/19/2012	12	3939.741	2012	11
11/19/2012	13	3929.142	2012	11
11/19/2012	14	3874.042	2012	11
11/19/2012	15	3779.342	2012	11
11/19/2012	16	3774.442	2012	11
11/19/2012	17	3948.142	2012	11
11/19/2012	18	4140.441	2012	11
11/19/2012	19	4097.741	2012	11
11/19/2012	20	4074.94	2012	11
11/19/2012	21	3935.14	2012	11
11/19/2012	22	3746.64	2012	11
11/19/2012	23	3556.539	2012	11
11/20/2012	0	3380.039	2012	11
11/20/2012	1	3302.44	2012	11
11/20/2012	2	3208.138	2012	11
11/20/2012	3	3211.64	2012	11
11/20/2012	4	3272.238	2012	11
11/20/2012	5	3425.039	2012	11
11/20/2012	6	3806.624	2012	11
11/20/2012	7	4076.424	2012	11
11/20/2012	8	4034.839	2012	11
11/20/2012	9	3973.939	2012	11
11/20/2012	10	3893.241	2012	11
11/20/2012	11	3863.542	2012	11
11/20/2012	12	3853.442	2012	11
11/20/2012	13	3786.043	2012	11
11/20/2012	14	3743.839	2012	11
11/20/2012	15	3681.542	2012	11
11/20/2012	16	3633.942	2012	11
11/20/2012	17	3816.343	2012	11
11/20/2012	18	3951.541	2012	11
11/20/2012	19	3882.542	2012	11
11/20/2012	20	3869.942	2012	11
11/20/2012	21	3713.834	2012	11

Day	Hr	Total	Year	Month
11/20/2012	22	3522.242	2012	11
11/20/2012	23	3329.341	2012	11
11/21/2012	0	3116.742	2012	11
11/21/2012	1	3037.442	2012	11
11/21/2012	2	2990.94	2012	11
11/21/2012	3	2960.442	2012	11
11/21/2012	4	3041.341	2012	11
11/21/2012	5	3228.14	2012	11
11/21/2012	6	3499.54	2012	11
11/21/2012	7	3756.433	2012	11
11/21/2012	8	3845.54	2012	11
11/21/2012	9	3872.84	2012	11
11/21/2012	10	3861.641	2012	11
11/21/2012	11	3775.441	2012	11
11/21/2012	12	3747.141	2012	11
11/21/2012	13	3682.841	2012	11
11/21/2012	14	3629.142	2012	11
11/21/2012	15	3562.142	2012	11
11/21/2012	16	3528.742	2012	11
11/21/2012	17	3640.343	2012	11
11/21/2012	18	3800.442	2012	11
11/21/2012	19	3746.141	2012	11
11/21/2012	20	3709.941	2012	11
11/21/2012	21	3608.341	2012	11
11/21/2012	22	3436.34	2012	11
11/21/2012	23	3221.939	2012	11
11/22/2012	0	3048.74	2012	11
11/22/2012	1	2904.839	2012	11
11/22/2012	2	2860.124	2012	11
11/22/2012	3	2857.221	2012	11
11/22/2012	4	2874.633	2012	11
11/22/2012	5	2959.537	2012	11
11/22/2012	6	3061.72	2012	11
11/22/2012	7	3170.521	2012	11
11/22/2012	8	3271.92	2012	11
11/22/2012	9	3271.035	2012	11
11/22/2012	10	3237.639	2012	11
11/22/2012	11	3163.941	2012	11
11/22/2012	12	3023.842	2012	11
11/22/2012	13	2839.042	2012	11
11/22/2012	14	2734.141	2012	11
11/22/2012	15	2631.142	2012	11
11/22/2012	16	2565.343	2012	11
11/22/2012	17	2667.642	2012	11
11/22/2012	18	2784.442	2012	11
11/22/2012	19	2783.841	2012	11
11/22/2012	20	2784.641	2012	11
11/22/2012	21	2796.141	2012	11
11/22/2012	22	2722.341	2012	11
11/22/2012	23	2653.242	2012	11
11/23/2012	0	2573.241	2012	11
11/23/2012	1	2504.941	2012	11
11/23/2012	2	2496.841	2012	11
11/23/2012	3	2492.842	2012	11
11/23/2012	4	2519.841	2012	11
11/23/2012	5	2594.542	2012	11
11/23/2012	6	2732.441	2012	11
11/23/2012	7	2866.14	2012	11
11/23/2012	8	2951.241	2012	11
11/23/2012	9	3048.84	2012	11
11/23/2012	10	3111.84	2012	11
11/23/2012	11	3132.129	2012	11
11/23/2012	12	3082.924	2012	11
11/23/2012	13	3031.035	2012	11

Day	Hr	Total	Year	Month
11/23/2012	14	2990.241	2012	11
11/23/2012	15	2968.724	2012	11
11/23/2012	16	2987.523	2012	11
11/23/2012	17	3225.63	2012	11
11/23/2012	18	3428.138	2012	11
11/23/2012	19	3447.438	2012	11
11/23/2012	20	3442.525	2012	11
11/23/2012	21	3416.421	2012	11
11/23/2012	22	3335.32	2012	11
11/23/2012	23	3222.12	2012	11
11/24/2012	0	3149.12	2012	11
11/24/2012	1	3098.319	2012	11
11/24/2012	2	3091.62	2012	11
11/24/2012	3	3102.119	2012	11
11/24/2012	4	3149.72	2012	11
11/24/2012	5	3257.419	2012	11
11/24/2012	6	3413.719	2012	11
11/24/2012	7	3577.12	2012	11
11/24/2012	8	3694.42	2012	11
11/24/2012	9	3750.12	2012	11
11/24/2012	10	3734.32	2012	11
11/24/2012	11	3660.419	2012	11
11/24/2012	12	3568.621	2012	11
11/24/2012	13	3453.922	2012	11
11/24/2012	14	3381.63	2012	11
11/24/2012	15	3334.938	2012	11
11/24/2012	16	3427.023	2012	11
11/24/2012	17	3710.22	2012	11
11/24/2012	18	3957.619	2012	11
11/24/2012	19	4005.12	2012	11
11/24/2012	20	4024.419	2012	11
11/24/2012	21	4013.62	2012	11
11/24/2012	22	3918.919	2012	11
11/24/2012	23	3803.42	2012	11
11/25/2012	0	3702.819	2012	11
11/25/2012	1	3612.42	2012	11
11/25/2012	2	3537.719	2012	11
11/25/2012	3	3568.919	2012	11
11/25/2012	4	3573.019	2012	11
11/25/2012	5	3617.02	2012	11
11/25/2012	6	3740.219	2012	11
11/25/2012	7	3819.62	2012	11
11/25/2012	8	3898.119	2012	11
11/25/2012	9	3895.421	2012	11
11/25/2012	10	3779.729	2012	11
11/25/2012	11	3628.039	2012	11
11/25/2012	12	3507.532	2012	11
11/25/2012	13	3362.225	2012	11
11/25/2012	14	3250.041	2012	11
11/25/2012	15	3242.542	2012	11
11/25/2012	16	3302.941	2012	11
11/25/2012	17	3542.74	2012	11
11/25/2012	18	3761.04	2012	11
11/25/2012	19	3786.739	2012	11
11/25/2012	20	3784.139	2012	11
11/25/2012	21	3662.638	2012	11
11/25/2012	22	3508.13	2012	11
11/25/2012	23	3371.721	2012	11
11/26/2012	0	3277.132	2012	11
11/26/2012	1	3240.137	2012	11
11/26/2012	2	3258.022	2012	11
11/26/2012	3	3305.22	2012	11
11/26/2012	4	3436.62	2012	11
11/26/2012	5	3705.42	2012	11

Day	Hr	Total	Year	Month
11/26/2012	6	4110.819	2012	11
11/26/2012	7	4375.82	2012	11
11/26/2012	8	4379.521	2012	11
11/26/2012	9	4276.227	2012	11
11/26/2012	10	4173.039	2012	11
11/26/2012	11	4074.839	2012	11
11/26/2012	12	4048.628	2012	11
11/26/2012	13	4037.931	2012	11
11/26/2012	14	4005.24	2012	11
11/26/2012	15	3975.14	2012	11
11/26/2012	16	4026.14	2012	11
11/26/2012	17	4256.14	2012	11
11/26/2012	18	4367.122	2012	11
11/26/2012	19	4368.809	2012	11
11/26/2012	20	4305.139	2012	11
11/26/2012	21	4110.835	2012	11
11/26/2012	22	3856.022	2012	11
11/26/2012	23	3699.222	2012	11
11/27/2012	0	3522.122	2012	11
11/27/2012	1	3458.821	2012	11
11/27/2012	2	3460.821	2012	11
11/27/2012	3	3437.421	2012	11
11/27/2012	4	3480.421	2012	11
11/27/2012	5	3723.52	2012	11
11/27/2012	6	4099.02	2012	11
11/27/2012	7	4408.721	2012	11
11/27/2012	8	4449.043	2012	11
11/27/2012	9	4472.253	2012	11
11/27/2012	10	4439.062	2012	11
11/27/2012	11	4426.561	2012	11
11/27/2012	12	4374.962	2012	11
11/27/2012	13	4353.356	2012	11
11/27/2012	14	4288.626	2012	11
11/27/2012	15	4239.727	2012	11
11/27/2012	16	4208.639	2012	11
11/27/2012	17	4446.826	2012	11
11/27/2012	18	4630.942	2012	11
11/27/2012	19	4651.532	2012	11
11/27/2012	20	4668.625	2012	11
11/27/2012	21	4552.935	2012	11
11/27/2012	22	4304.44	2012	11
11/27/2012	23	4133.53	2012	11
11/28/2012	0	4004.224	2012	11
11/28/2012	1	3969.923	2012	11
11/28/2012	2	3959.136	2012	11
11/28/2012	3	3964.14	2012	11
11/28/2012	4	3998.624	2012	11
11/28/2012	5	4266.222	2012	11
11/28/2012	6	4659.223	2012	11
11/28/2012	7	4899.227	2012	11
11/28/2012	8	4896.061	2012	11
11/28/2012	9	4715.335	2012	11
11/28/2012	10	4543.146	2012	11
11/28/2012	11	4341.142	2012	11
11/28/2012	12	4275.237	2012	11
11/28/2012	13	4190.031	2012	11
11/28/2012	14	4052.644	2012	11
11/28/2012	15	3968.243	2012	11
11/28/2012	16	4016.743	2012	11
11/28/2012	17	4311.542	2012	11
11/28/2012	18	4565.741	2012	11
11/28/2012	19	4646.741	2012	11
11/28/2012	20	4714.341	2012	11
11/28/2012	21	4610.226	2012	11

Day	Hr	Total	Year	Month
11/28/2012	22	4461.325	2012	11
11/28/2012	23	4223.841	2012	11
11/29/2012	0	4121.14	2012	11
11/29/2012	1	4070.925	2012	11
11/29/2012	2	4080.324	2012	11
11/29/2012	3	4040.128	2012	11
11/29/2012	4	4175.039	2012	11
11/29/2012	5	4398.43	2012	11
11/29/2012	6	4773.123	2012	11
11/29/2012	7	5010.523	2012	11
11/29/2012	8	4958.625	2012	11
11/29/2012	9	4763.741	2012	11
11/29/2012	10	4537.043	2012	11
11/29/2012	11	4347.642	2012	11
11/29/2012	12	4222.644	2012	11
11/29/2012	13	4118.843	2012	11
11/29/2012	14	3980.344	2012	11
11/29/2012	15	3931.543	2012	11
11/29/2012	16	3913.656	2012	11
11/29/2012	17	4206.662	2012	11
11/29/2012	18	4416.761	2012	11
11/29/2012	19	4444.461	2012	11
11/29/2012	20	4439.951	2012	11
11/29/2012	21	4372.147	2012	11
11/29/2012	22	4139.36	2012	11
11/29/2012	23	3942.761	2012	11
11/30/2012	0	3768.661	2012	11
11/30/2012	1	3646.261	2012	11
11/30/2012	2	3578.761	2012	11
11/30/2012	3	3546.461	2012	11
11/30/2012	4	3636.561	2012	11
11/30/2012	5	3819.262	2012	11
11/30/2012	6	4204.345	2012	11
11/30/2012	7	4478.059	2012	11
11/30/2012	8	4428.761	2012	11
11/30/2012	9	4252.662	2012	11
11/30/2012	10	4149.462	2012	11
11/30/2012	11	4025.862	2012	11
11/30/2012	12	3986.363	2012	11
11/30/2012	13	3850.262	2012	11
11/30/2012	14	3812.163	2012	11
11/30/2012	15	3689.362	2012	11
11/30/2012	16	3709.447	2012	11
11/30/2012	17	3904.76	2012	11
11/30/2012	18	4033.061	2012	11
11/30/2012	19	3993.062	2012	11
11/30/2012	20	4039.662	2012	11
11/30/2012	21	3931.561	2012	11
11/30/2012	22	3779.362	2012	11
11/30/2012	23	3618.861	2012	11
12/1/2012	0	3444.06	2012	12
12/1/2012	1	3331.645	2012	12
12/1/2012	2	3251.361	2012	12
12/1/2012	3	3127.962	2012	12
12/1/2012	4	3141.061	2012	12
12/1/2012	5	3206.362	2012	12
12/1/2012	6	3348.162	2012	12
12/1/2012	7	3477.162	2012	12
12/1/2012	8	3587.962	2012	12
12/1/2012	9	3643.862	2012	12
12/1/2012	10	3629.546	2012	12
12/1/2012	11	3546.462	2012	12
12/1/2012	12	3461.262	2012	12
12/1/2012	13	3356.462	2012	12

Day	Hr	Total	Year	Month
12/1/2012	14	3316.263	2012	12
12/1/2012	15	3274.162	2012	12
12/1/2012	16	3274.562	2012	12
12/1/2012	17	3442.763	2012	12
12/1/2012	18	3576.313	2012	12
12/1/2012	19	3618.462	2012	12
12/1/2012	20	3520.863	2012	12
12/1/2012	21	3465.562	2012	12
12/1/2012	22	3312.047	2012	12
12/1/2012	23	3155.159	2012	12
12/2/2012	0	2969.762	2012	12
12/2/2012	1	2824.262	2012	12
12/2/2012	2	2791.262	2012	12
12/2/2012	3	2754.063	2012	12
12/2/2012	4	2758.862	2012	12
12/2/2012	5	2824.263	2012	12
12/2/2012	6	2878.562	2012	12
12/2/2012	7	3005.463	2012	12
12/2/2012	8	3113.162	2012	12
12/2/2012	9	3195.363	2012	12
12/2/2012	10	3164.849	2012	12
12/2/2012	11	3212.157	2012	12
12/2/2012	12	3243.663	2012	12
12/2/2012	13	3237.662	2012	12
12/2/2012	14	3217.063	2012	12
12/2/2012	15	3232.162	2012	12
12/2/2012	16	3294.163	2012	12
12/2/2012	17	3538.662	2012	12
12/2/2012	18	3653.662	2012	12
12/2/2012	19	3626.763	2012	12
12/2/2012	20	3560.262	2012	12
12/2/2012	21	3418.866	2012	12
12/2/2012	22	3268.467	2012	12
12/2/2012	23	3052.266	2012	12
12/3/2012	0	2849.251	2012	12
12/3/2012	1	2802.261	2012	12
12/3/2012	2	2733.679	2012	12
12/3/2012	3	2755.764	2012	12
12/3/2012	4	2814.367	2012	12
12/3/2012	5	2979.962	2012	12
12/3/2012	6	3393.967	2012	12
12/3/2012	7	3682.763	2012	12
12/3/2012	8	3708.166	2012	12
12/3/2012	9	3720.565	2012	12
12/3/2012	10	3750.167	2012	12
12/3/2012	11	3752.367	2012	12
12/3/2012	12	3771.068	2012	12
12/3/2012	13	3837.568	2012	12
12/3/2012	14	3840.169	2012	12
12/3/2012	15	3818.067	2012	12
12/3/2012	16	3750.069	2012	12
12/3/2012	17	3893.168	2012	12
12/3/2012	18	4087.453	2012	12
12/3/2012	19	4025.26	2012	12
12/3/2012	20	3969.864	2012	12
12/3/2012	21	3799.966	2012	12
12/3/2012	22	3582.262	2012	12
12/3/2012	23	3337.067	2012	12
12/4/2012	0	3121.764	2012	12
12/4/2012	1	3023.164	2012	12
12/4/2012	2	2933.667	2012	12
12/4/2012	3	2814.463	2012	12
12/4/2012	4	2850.265	2012	12
12/4/2012	5	3094.463	2012	12

Day	Hr	Total	Year	Month
12/4/2012	6	3428.966	2012	12
12/4/2012	7	3746.966	2012	12
12/4/2012	8	3792.063	2012	12
12/4/2012	9	3823.765	2012	12
12/4/2012	10	3842.765	2012	12
12/4/2012	11	3832.455	2012	12
12/4/2012	12	3903.754	2012	12
12/4/2012	13	3905.567	2012	12
12/4/2012	14	3883.765	2012	12
12/4/2012	15	3897.521	2012	12
12/4/2012	16	3905.466	2012	12
12/4/2012	17	4042.567	2012	12
12/4/2012	18	4086.403	2012	12
12/4/2012	19	4054.562	2012	12
12/4/2012	20	3977.062	2012	12
12/4/2012	21	3809.562	2012	12
12/4/2012	22	3638.263	2012	12
12/4/2012	23	3390.16	2012	12
12/5/2012	0	3201.045	2012	12
12/5/2012	1	3112.76	2012	12
12/5/2012	2	2986.761	2012	12
12/5/2012	3	2971.462	2012	12
12/5/2012	4	3087.861	2012	12
12/5/2012	5	3324.661	2012	12
12/5/2012	6	3794.361	2012	12
12/5/2012	7	4113.761	2012	12
12/5/2012	8	4112.762	2012	12
12/5/2012	9	4070.047	2012	12
12/5/2012	10	4002.859	2012	12
12/5/2012	11	3924.563	2012	12
12/5/2012	12	3867.862	2012	12
12/5/2012	13	3868.762	2012	12
12/5/2012	14	3812.463	2012	12
12/5/2012	15	3782.862	2012	12
12/5/2012	16	3761.663	2012	12
12/5/2012	17	4025.162	2012	12
12/5/2012	18	4265.161	2012	12
12/5/2012	19	4242.145	2012	12
12/5/2012	20	4271.762	2012	12
12/5/2012	21	4243.261	2012	12
12/5/2012	22	4022.862	2012	12
12/5/2012	23	3819.162	2012	12
12/6/2012	0	3690.262	2012	12
12/6/2012	1	3569.261	2012	12
12/6/2012	2	3542.261	2012	12
12/6/2012	3	3563.255	2012	12
12/6/2012	4	3667.149	2012	12
12/6/2012	5	3920.261	2012	12
12/6/2012	6	4328.86	2012	12
12/6/2012	7	4580.861	2012	12
12/6/2012	8	4558.361	2012	12
12/6/2012	9	4486.456	2012	12
12/6/2012	10	4377.672	2012	12
12/6/2012	11	4231.458	2012	12
12/6/2012	12	4222.155	2012	12
12/6/2012	13	4143.551	2012	12
12/6/2012	14	4079.952	2012	12
12/6/2012	15	4016.454	2012	12
12/6/2012	16	4077.25	2012	12
12/6/2012	17	4265.649	2012	12
12/6/2012	18	4367.365	2012	12
12/6/2012	19	4310.35	2012	12
12/6/2012	20	4237.097	2012	12
12/6/2012	21	4146.848	2012	12

Day	Hr	Total	Year	Month
12/6/2012	22	3899.443	2012	12
12/6/2012	23	3649.844	2012	12
12/7/2012	0	3438.443	2012	12
12/7/2012	1	3294.144	2012	12
12/7/2012	2	3269.643	2012	12
12/7/2012	3	3177.143	2012	12
12/7/2012	4	3212.943	2012	12
12/7/2012	5	3359.337	2012	12
12/7/2012	6	3713.227	2012	12
12/7/2012	7	3992.239	2012	12
12/7/2012	8	4018.144	2012	12
12/7/2012	9	4047.843	2012	12
12/7/2012	10	4044.544	2012	12
12/7/2012	11	4004.043	2012	12
12/7/2012	12	4031.044	2012	12
12/7/2012	13	3972.444	2012	12
12/7/2012	14	3921.943	2012	12
12/7/2012	15	3890.344	2012	12
12/7/2012	16	3893.444	2012	12
12/7/2012	17	4058.143	2012	12
12/7/2012	18	4061.044	2012	12
12/7/2012	19	3983.747	2012	12
12/7/2012	20	3924.444	2012	12
12/7/2012	21	3755.647	2012	12
12/7/2012	22	3607.944	2012	12
12/7/2012	23	3424.847	2012	12
12/8/2012	0	3186.144	2012	12
12/8/2012	1	3045.544	2012	12
12/8/2012	2	2923.947	2012	12
12/8/2012	3	2891.945	2012	12
12/8/2012	4	2875.344	2012	12
12/8/2012	5	2915.648	2012	12
12/8/2012	6	3007.445	2012	12
12/8/2012	7	3179.746	2012	12
12/8/2012	8	3288.347	2012	12
12/8/2012	9	3456.445	2012	12
12/8/2012	10	3515.744	2012	12
12/8/2012	11	3520.658	2012	12
12/8/2012	12	3464.761	2012	12
12/8/2012	13	3454.667	2012	12
12/8/2012	14	3379.267	2012	12
12/8/2012	15	3388.162	2012	12
12/8/2012	16	3395.563	2012	12
12/8/2012	17	3595.755	2012	12
12/8/2012	18	3679.846	2012	12
12/8/2012	19	3646.063	2012	12
12/8/2012	20	3525.662	2012	12
12/8/2012	21	3466.962	2012	12
12/8/2012	22	3338.762	2012	12
12/8/2012	23	3156.262	2012	12
12/9/2012	0	2977.463	2012	12
12/9/2012	1	2858.062	2012	12
12/9/2012	2	2808.462	2012	12
12/9/2012	3	2775.962	2012	12
12/9/2012	4	2770.069	2012	12
12/9/2012	5	2790.054	2012	12
12/9/2012	6	2857.262	2012	12
12/9/2012	7	3047.562	2012	12
12/9/2012	8	3160.662	2012	12
12/9/2012	9	3265.863	2012	12
12/9/2012	10	3311.162	2012	12
12/9/2012	11	3311.663	2012	12
12/9/2012	12	3332.867	2012	12
12/9/2012	13	3301.964	2012	12

Day	Hr	Total	Year	Month
12/9/2012	14	3281.365	2012	12
12/9/2012	15	3262.167	2012	12
12/9/2012	16	3372.748	2012	12
12/9/2012	17	3572.86	2012	12
12/9/2012	18	3662.264	2012	12
12/9/2012	19	3673.462	2012	12
12/9/2012	20	3666.363	2012	12
12/9/2012	21	3499.662	2012	12
12/9/2012	22	3297.762	2012	12
12/9/2012	23	3120.562	2012	12
12/10/2012	0	2917.962	2012	12
12/10/2012	1	2813.866	2012	12
12/10/2012	2	2823.263	2012	12
12/10/2012	3	2790.561	2012	12
12/10/2012	4	2900.545	2012	12
12/10/2012	5	3144.66	2012	12
12/10/2012	6	3530.862	2012	12
12/10/2012	7	3889.162	2012	12
12/10/2012	8	3994.761	2012	12
12/10/2012	9	4053.962	2012	12
12/10/2012	10	4138.961	2012	12
12/10/2012	11	4170.161	2012	12
12/10/2012	12	4256.575	2012	12
12/10/2012	13	4286.546	2012	12
12/10/2012	14	4330.259	2012	12
12/10/2012	15	4316.561	2012	12
12/10/2012	16	4378.46	2012	12
12/10/2012	17	4594.861	2012	12
12/10/2012	18	4730.26	2012	12
12/10/2012	19	4703.76	2012	12
12/10/2012	20	4704.56	2012	12
12/10/2012	21	4565.443	2012	12
12/10/2012	22	4355.059	2012	12
12/10/2012	23	4110.059	2012	12
12/11/2012	0	3903.159	2012	12
12/11/2012	1	3856.965	2012	12
12/11/2012	2	3785.259	2012	12
12/11/2012	3	3752.659	2012	12
12/11/2012	4	3830.145	2012	12
12/11/2012	5	4021.455	2012	12
12/11/2012	6	4452.959	2012	12
12/11/2012	7	4733.86	2012	12
12/11/2012	8	4748.259	2012	12
12/11/2012	9	4756.16	2012	12
12/11/2012	10	4727.658	2012	12
12/11/2012	11	4681.745	2012	12
12/11/2012	12	4659.662	2012	12
12/11/2012	13	4567.062	2012	12
12/11/2012	14	4434.162	2012	12
12/11/2012	15	4332.162	2012	12
12/11/2012	16	4341.462	2012	12
12/11/2012	17	4622.261	2012	12
12/11/2012	18	4913.447	2012	12
12/11/2012	19	4924.555	2012	12
12/11/2012	20	4956.259	2012	12
12/11/2012	21	4885.759	2012	12
12/11/2012	22	4657.059	2012	12
12/11/2012	23	4449.658	2012	12
12/12/2012	0	4335.258	2012	12
12/12/2012	1	4269.242	2012	12
12/12/2012	2	4165.758	2012	12
12/12/2012	3	4206.058	2012	12
12/12/2012	4	4323.659	2012	12
12/12/2012	5	4537.058	2012	12

Day	Hr	Total	Year	Month
12/12/2012	6	4931.858	2012	12
12/12/2012	7	5263.881	2012	12
12/12/2012	8	5200.056	2012	12
12/12/2012	9	5013.36	2012	12
12/12/2012	10	4806.061	2012	12
12/12/2012	11	4602.261	2012	12
12/12/2012	12	4481.362	2012	12
12/12/2012	13	4378.062	2012	12
12/12/2012	14	4216.646	2012	12
12/12/2012	15	4135.562	2012	12
12/12/2012	16	4155.263	2012	12
12/12/2012	17	4441.961	2012	12
12/12/2012	18	4730.261	2012	12
12/12/2012	19	4792.76	2012	12
12/12/2012	20	4785.66	2012	12
12/12/2012	21	4714.148	2012	12
12/12/2012	22	4497.452	2012	12
12/12/2012	23	4309.638	2012	12
12/13/2012	0	4218.159	2012	12
12/13/2012	1	4162.358	2012	12
12/13/2012	2	4112.058	2012	12
12/13/2012	3	4099.456	2012	12
12/13/2012	4	4173.243	2012	12
12/13/2012	5	4457.959	2012	12
12/13/2012	6	4890.958	2012	12
12/13/2012	7	5169.258	2012	12
12/13/2012	8	5099.859	2012	12
12/13/2012	9	4918.56	2012	12
12/13/2012	10	4640.545	2012	12
12/13/2012	11	4486.76	2012	12
12/13/2012	12	4342.807	2012	12
12/13/2012	13	4228.462	2012	12
12/13/2012	14	4081.363	2012	12
12/13/2012	15	4028.862	2012	12
12/13/2012	16	3985.162	2012	12
12/13/2012	17	4304.358	2012	12
12/13/2012	18	4536.547	2012	12
12/13/2012	19	4543.46	2012	12
12/13/2012	20	4618.26	2012	12
12/13/2012	21	4603.26	2012	12
12/13/2012	22	4397.859	2012	12
12/13/2012	23	4218.46	2012	12
12/14/2012	0	4100.554	2012	12
12/14/2012	1	4024.746	2012	12
12/14/2012	2	3946.659	2012	12
12/14/2012	3	4005.459	2012	12
12/14/2012	4	4067.959	2012	12
12/14/2012	5	4281.759	2012	12
12/14/2012	6	4654.058	2012	12
12/14/2012	7	4902.144	2012	12
12/14/2012	8	4888.857	2012	12
12/14/2012	9	4682.06	2012	12
12/14/2012	10	4463.861	2012	12
12/14/2012	11	4241.562	2012	12
12/14/2012	12	4121.262	2012	12
12/14/2012	13	4026.362	2012	12
12/14/2012	14	3907.555	2012	12
12/14/2012	15	3807.653	2012	12
12/14/2012	16	3795.563	2012	12
12/14/2012	17	4110.762	2012	12
12/14/2012	18	4277.961	2012	12
12/14/2012	19	4201.362	2012	12
12/14/2012	20	4222.061	2012	12
12/14/2012	21	4151.461	2012	12

Day	Hr	Total	Year	Month
12/14/2012	22	3967.254	2012	12
12/14/2012	23	3824.851	2012	12
12/15/2012	0	3614.262	2012	12
12/15/2012	1	3485.562	2012	12
12/15/2012	2	3411.261	2012	12
12/15/2012	3	3331.162	2012	12
12/15/2012	4	3337.962	2012	12
12/15/2012	5	3412.661	2012	12
12/15/2012	6	3539.95	2012	12
12/15/2012	7	3778.156	2012	12
12/15/2012	8	3820.762	2012	12
12/15/2012	9	3936.862	2012	12
12/15/2012	10	3933.562	2012	12
12/15/2012	11	3902.263	2012	12
12/15/2012	12	3815.562	2012	12
12/15/2012	13	3751.347	2012	12
12/15/2012	14	3681.85	2012	12
12/15/2012	15	3597.056	2012	12
12/15/2012	16	3656.462	2012	12
12/15/2012	17	3856.163	2012	12
12/15/2012	18	3901.862	2012	12
12/15/2012	19	3826.463	2012	12
12/15/2012	20	3761.262	2012	12
12/15/2012	21	3664.762	2012	12
12/15/2012	22	3503.563	2012	12
12/15/2012	23	3270.846	2012	12
12/16/2012	0	3046.56	2012	12
12/16/2012	1	2963.162	2012	12
12/16/2012	2	2802.662	2012	12
12/16/2012	3	2802.662	2012	12
12/16/2012	4	2756.463	2012	12
12/16/2012	5	2823.962	2012	12
12/16/2012	6	2882.363	2012	12
12/16/2012	7	3040.862	2012	12
12/16/2012	8	3163.363	2012	12
12/16/2012	9	3299.046	2012	12
12/16/2012	10	3335.661	2012	12
12/16/2012	11	3344.562	2012	12
12/16/2012	12	3344.863	2012	12
12/16/2012	13	3311.762	2012	12
12/16/2012	14	3274.362	2012	12
12/16/2012	15	3338.363	2012	12
12/16/2012	16	3349.562	2012	12
12/16/2012	17	3597.862	2012	12
12/16/2012	18	3708.462	2012	12
12/16/2012	19	3673.162	2012	12
12/16/2012	20	3647.95	2012	12
12/16/2012	21	3571.354	2012	12
12/16/2012	22	3331.562	2012	12
12/16/2012	23	3106.462	2012	12
12/17/2012	0	2959.462	2012	12
12/17/2012	1	2835.162	2012	12
12/17/2012	2	2833.862	2012	12
12/17/2012	3	2866.662	2012	12
12/17/2012	4	2894.262	2012	12
12/17/2012	5	3155.463	2012	12
12/17/2012	6	3476.462	2012	12
12/17/2012	7	3835.35	2012	12
12/17/2012	8	3893.855	2012	12
12/17/2012	9	3948.363	2012	12
12/17/2012	10	3981.161	2012	12
12/17/2012	11	3939.71	2012	12
12/17/2012	12	3946.163	2012	12
12/17/2012	13	3933.262	2012	12

Day	Hr	Total	Year	Month
12/17/2012	14	3894.663	2012	12
12/17/2012	15	3816.863	2012	12
12/17/2012	16	3913.963	2012	12
12/17/2012	17	4070.562	2012	12
12/17/2012	18	4215.158	2012	12
12/17/2012	19	4230.247	2012	12
12/17/2012	20	4186.263	2012	12
12/17/2012	21	4087.362	2012	12
12/17/2012	22	3862.562	2012	12
12/17/2012	23	3635.062	2012	12
12/18/2012	0	3422.161	2012	12
12/18/2012	1	3338.461	2012	12
12/18/2012	2	3277.361	2012	12
12/18/2012	3	3243.956	2012	12
12/18/2012	4	3305.948	2012	12
12/18/2012	5	3548.761	2012	12
12/18/2012	6	3932.962	2012	12
12/18/2012	7	4277.16	2012	12
12/18/2012	8	4307.762	2012	12
12/18/2012	9	4329.761	2012	12
12/18/2012	10	4353.862	2012	12
12/18/2012	11	4306.258	2012	12
12/18/2012	12	4353.247	2012	12
12/18/2012	13	4276.062	2012	12
12/18/2012	14	4151.262	2012	12
12/18/2012	15	4093.058	2012	12
12/18/2012	16	4056.762	2012	12
12/18/2012	17	4234.263	2012	12
12/18/2012	18	4529.662	2012	12
12/18/2012	19	4481.362	2012	12
12/18/2012	20	4524.547	2012	12
12/18/2012	21	4391.558	2012	12
12/18/2012	22	4177.461	2012	12
12/18/2012	23	3949.562	2012	12
12/19/2012	0	3713.062	2012	12
12/19/2012	1	3606.861	2012	12
12/19/2012	2	3527.261	2012	12
12/19/2012	3	3488.262	2012	12
12/19/2012	4	3562.55	2012	12
12/19/2012	5	3763.255	2012	12
12/19/2012	6	4164.562	2012	12
12/19/2012	7	4445.661	2012	12
12/19/2012	8	4406.961	2012	12
12/19/2012	9	4354.762	2012	12
12/19/2012	10	4225.862	2012	12
12/19/2012	11	4081.962	2012	12
12/19/2012	12	4046.551	2012	12
12/19/2012	13	3986.855	2012	12
12/19/2012	14	3899.862	2012	12
12/19/2012	15	3847.02	2012	12
12/19/2012	16	3843.662	2012	12
12/19/2012	17	4084.162	2012	12
12/19/2012	18	4296.062	2012	12
12/19/2012	19	4262.861	2012	12
12/19/2012	20	4319.76	2012	12
12/19/2012	21	4185.645	2012	12
12/19/2012	22	3974.961	2012	12
12/19/2012	23	3806.862	2012	12
12/20/2012	0	3589.361	2012	12
12/20/2012	1	3472.762	2012	12
12/20/2012	2	3374.86	2012	12
12/20/2012	3	3314.262	2012	12
12/20/2012	4	3349.362	2012	12
12/20/2012	5	3531.834	2012	12

Day	Hr	Total	Year	Month
12/20/2012	6	3810.874	2012	12
12/20/2012	7	4075.062	2012	12
12/20/2012	8	4158.763	2012	12
12/20/2012	9	4185.062	2012	12
12/20/2012	10	4189.363	2012	12
12/20/2012	11	4191.363	2012	12
12/20/2012	12	4272.562	2012	12
12/20/2012	13	4276.353	2012	12
12/20/2012	14	4225.055	2012	12
12/20/2012	15	4231.862	2012	12
12/20/2012	16	4290.261	2012	12
12/20/2012	17	4509.461	2012	12
12/20/2012	18	4645.66	2012	12
12/20/2012	19	4675.26	2012	12
12/20/2012	20	4670.841	2012	12
12/20/2012	21	4625.955	2012	12
12/20/2012	22	4532.057	2012	12
12/20/2012	23	4303.458	2012	12
12/21/2012	0	4229.658	2012	12
12/21/2012	1	4141.056	2012	12
12/21/2012	2	4109.842	2012	12
12/21/2012	3	4100.556	2012	12
12/21/2012	4	4171.957	2012	12
12/21/2012	5	4375.758	2012	12
12/21/2012	6	4628.457	2012	12
12/21/2012	7	4906.346	2012	12
12/21/2012	8	5026.951	2012	12
12/21/2012	9	5111.86	2012	12
12/21/2012	10	5164.058	2012	12
12/21/2012	11	5103.258	2012	12
12/21/2012	12	5069.652	2012	12
12/21/2012	13	4954.748	2012	12
12/21/2012	14	4882.06	2012	12
12/21/2012	15	4807.16	2012	12
12/21/2012	16	4783.86	2012	12
12/21/2012	17	4910.66	2012	12
12/21/2012	18	5054.25	2012	12
12/21/2012	19	4951.753	2012	12
12/21/2012	20	4879.059	2012	12
12/21/2012	21	4823.261	2012	12
12/21/2012	22	4700.76	2012	12
12/21/2012	23	4437.659	2012	12
12/22/2012	0	4249.248	2012	12
12/22/2012	1	4052.654	2012	12
12/22/2012	2	3990.159	2012	12
12/22/2012	3	3972.659	2012	12
12/22/2012	4	4020.259	2012	12
12/22/2012	5	4090.554	2012	12
12/22/2012	6	4208.744	2012	12
12/22/2012	7	4406.659	2012	12
12/22/2012	8	4466.858	2012	12
12/22/2012	9	4422.459	2012	12
12/22/2012	10	4309.034	2012	12
12/22/2012	11	4139.449	2012	12
12/22/2012	12	3970.756	2012	12
12/22/2012	13	3808.163	2012	12
12/22/2012	14	3679.962	2012	12
12/22/2012	15	3649.863	2012	12
12/22/2012	16	3714.263	2012	12
12/22/2012	17	3982.559	2012	12
12/22/2012	18	4282.145	2012	12
12/22/2012	19	4326.559	2012	12
12/22/2012	20	4318.459	2012	12
12/22/2012	21	4326.559	2012	12

Day	Hr	Total	Year	Month
12/22/2012	22	4197.156	2012	12
12/22/2012	23	4083.659	2012	12
12/23/2012	0	3911.743	2012	12
12/23/2012	1	3783.658	2012	12
12/23/2012	2	3737.759	2012	12
12/23/2012	3	3739.76	2012	12
12/23/2012	4	3754.26	2012	12
12/23/2012	5	3809.057	2012	12
12/23/2012	6	3846.148	2012	12
12/23/2012	7	3986.461	2012	12
12/23/2012	8	4031.262	2012	12
12/23/2012	9	4066.061	2012	12
12/23/2012	10	3895.162	2012	12
12/23/2012	11	3762.263	2012	12
12/23/2012	12	3635.15	2012	12
12/23/2012	13	3494.359	2012	12
12/23/2012	14	3360.263	2012	12
12/23/2012	15	3327.563	2012	12
12/23/2012	16	3321.463	2012	12
12/23/2012	17	3534.663	2012	12
12/23/2012	18	3767.162	2012	12
12/23/2012	19	3779.162	2012	12
12/23/2012	20	3808.446	2012	12
12/23/2012	21	3718.46	2012	12
12/23/2012	22	3617.562	2012	12
12/23/2012	23	3396.062	2012	12
12/24/2012	0	3210.262	2012	12
12/24/2012	1	3076.862	2012	12
12/24/2012	2	2976.262	2012	12
12/24/2012	3	3004.855	2012	12
12/24/2012	4	3021.552	2012	12
12/24/2012	5	3045.662	2012	12
12/24/2012	6	3145.962	2012	12
12/24/2012	7	3289.263	2012	12
12/24/2012	8	3407.462	2012	12
12/24/2012	9	3523.463	2012	12
12/24/2012	10	3615.363	2012	12
12/24/2012	11	3580.249	2012	12
12/24/2012	12	3575.259	2012	12
12/24/2012	13	3460.08	2012	12
12/24/2012	14	3383.963	2012	12
12/24/2012	15	3351.263	2012	12
12/24/2012	16	3346.962	2012	12
12/24/2012	17	3448.262	2012	12
12/24/2012	18	3478.459	2012	12
12/24/2012	19	3416.347	2012	12
12/24/2012	20	3405.162	2012	12
12/24/2012	21	3395.462	2012	12
12/24/2012	22	3306.062	2012	12
12/24/2012	23	3209.661	2012	12
12/25/2012	0	3092.062	2012	12
12/25/2012	1	3004.462	2012	12
12/25/2012	2	2987.047	2012	12
12/25/2012	3	2991.758	2012	12
12/25/2012	4	3013.462	2012	12
12/25/2012	5	3096.462	2012	12
12/25/2012	6	3188.361	2012	12
12/25/2012	7	3334.861	2012	12
12/25/2012	8	3458.76	2012	12
12/25/2012	9	3585.747	2012	12
12/25/2012	10	3606.062	2012	12
12/25/2012	11	3606.562	2012	12
12/25/2012	12	3566.463	2012	12
12/25/2012	13	3478.662	2012	12

Day	Hr	Total	Year	Month
12/25/2012	14	3421.762	2012	12
12/25/2012	15	3398.553	2012	12
12/25/2012	16	3422.154	2012	12
12/25/2012	17	3598.262	2012	12
12/25/2012	18	3694.262	2012	12
12/25/2012	19	3733.061	2012	12
12/25/2012	20	3775.026	2012	12
12/25/2012	21	3772.251	2012	12
12/25/2012	22	3680.354	2012	12
12/25/2012	23	3611.062	2012	12
12/26/2012	0	3494.761	2012	12
12/26/2012	1	3386.861	2012	12
12/26/2012	2	3351.559	2012	12
12/26/2012	3	3375.045	2012	12
12/26/2012	4	3473.36	2012	12
12/26/2012	5	3584.861	2012	12
12/26/2012	6	3780.06	2012	12
12/26/2012	7	3970.261	2012	12
12/26/2012	8	4058.951	2012	12
12/26/2012	9	4169.353	2012	12
12/26/2012	10	4213.661	2012	12
12/26/2012	11	4206.461	2012	12
12/26/2012	12	4289.761	2012	12
12/26/2012	13	4248.36	2012	12
12/26/2012	14	4287.943	2012	12
12/26/2012	15	4288.561	2012	12
12/26/2012	16	4371.561	2012	12
12/26/2012	17	4569.361	2012	12
12/26/2012	18	4654.56	2012	12
12/26/2012	19	4635.953	2012	12
12/26/2012	20	4617.551	2012	12
12/26/2012	21	4475.861	2012	12
12/26/2012	22	4319.46	2012	12
12/26/2012	23	4145.56	2012	12
12/27/2012	0	3982.696	2012	12
12/27/2012	1	3897.747	2012	12
12/27/2012	2	3852.454	2012	12
12/27/2012	3	3812.66	2012	12
12/27/2012	4	3844.66	2012	12
12/27/2012	5	3967.459	2012	12
12/27/2012	6	4150.359	2012	12
12/27/2012	7	4393.342	2012	12
12/27/2012	8	4491.243	2012	12
12/27/2012	9	4564.44	2012	12
12/27/2012	10	4627.74	2012	12
12/27/2012	11	4650.14	2012	12
12/27/2012	12	4632.641	2012	12
12/27/2012	13	4598.541	2012	12
12/27/2012	14	4529.04	2012	12
12/27/2012	15	4398.94	2012	12
12/27/2012	16	4410.939	2012	12
12/27/2012	17	4588.238	2012	12
12/27/2012	18	4668.94	2012	12
12/27/2012	19	4688.74	2012	12
12/27/2012	20	4557.24	2012	12
12/27/2012	21	4475.541	2012	12
12/27/2012	22	4237.14	2012	12
12/27/2012	23	4080.241	2012	12
12/28/2012	0	3870.84	2012	12
12/28/2012	1	3800.84	2012	12
12/28/2012	2	3803.94	2012	12
12/28/2012	3	3750.539	2012	12
12/28/2012	4	3806.041	2012	12
12/28/2012	5	3930.54	2012	12

Day	Hr	Total	Year	Month
12/28/2012	6	4135.941	2012	12
12/28/2012	7	4332.54	2012	12
12/28/2012	8	4401.54	2012	12
12/28/2012	9	4417.753	2012	12
12/28/2012	10	4450.628	2012	12
12/28/2012	11	4397.741	2012	12
12/28/2012	12	4340.056	2012	12
12/28/2012	13	4211.161	2012	12
12/28/2012	14	4187.161	2012	12
12/28/2012	15	4063.562	2012	12
12/28/2012	16	4090.161	2012	12
12/28/2012	17	4287.261	2012	12
12/28/2012	18	4307.453	2012	12
12/28/2012	19	4283.451	2012	12
12/28/2012	20	4197.96	2012	12
12/28/2012	21	4121.961	2012	12
12/28/2012	22	4003.759	2012	12
12/28/2012	23	3835.061	2012	12
12/29/2012	0	3702.158	2012	12
12/29/2012	1	3622.843	2012	12
12/29/2012	2	3576.56	2012	12
12/29/2012	3	3558.059	2012	12
12/29/2012	4	3567.76	2012	12
12/29/2012	5	3649.06	2012	12
12/29/2012	6	3737.66	2012	12
12/29/2012	7	3890.744	2012	12
12/29/2012	8	3998.66	2012	12
12/29/2012	9	4133.06	2012	12
12/29/2012	10	4249.959	2012	12
12/29/2012	11	4296.159	2012	12
12/29/2012	12	4283.759	2012	12
12/29/2012	13	4249.143	2012	12
12/29/2012	14	4217.459	2012	12
12/29/2012	15	4264.661	2012	12
12/29/2012	16	4310.159	2012	12
12/29/2012	17	4519.06	2012	12
12/29/2012	18	4671.956	2012	12
12/29/2012	19	4666.244	2012	12
12/29/2012	20	4639.959	2012	12
12/29/2012	21	4555.557	2012	12
12/29/2012	22	4417.059	2012	12
12/29/2012	23	4241.258	2012	12
12/30/2012	0	4111.246	2012	12
12/30/2012	1	4013.751	2012	12
12/30/2012	2	3975.557	2012	12
12/30/2012	3	3971.457	2012	12
12/30/2012	4	3981.557	2012	12
12/30/2012	5	4030.751	2012	12
12/30/2012	6	4157.746	2012	12
12/30/2012	7	4235.258	2012	12
12/30/2012	8	4319.159	2012	12
12/30/2012	9	4302.859	2012	12
12/30/2012	10	4192.756	2012	12
12/30/2012	11	4070.346	2012	12
12/30/2012	12	3963.46	2012	12
12/30/2012	13	3875.76	2012	12
12/30/2012	14	3870.461	2012	12
12/30/2012	15	3769.462	2012	12
12/30/2012	16	3898.857	2012	12
12/30/2012	17	4208.046	2012	12
12/30/2012	18	4451.659	2012	12
12/30/2012	19	4463.558	2012	12
12/30/2012	20	4452.958	2012	12
12/30/2012	21	4358.758	2012	12

Day	Hr	Total	Year	Month
12/30/2012	22	4267.751	2012	12
12/30/2012	23	4145.448	2012	12
12/31/2012	0	4032.158	2012	12
12/31/2012	1	3978.958	2012	12
12/31/2012	2	3935.059	2012	12
12/31/2012	3	3970.159	2012	12
12/31/2012	4	3964.045	2012	12
12/31/2012	5	4010.755	2012	12
12/31/2012	6	4132.059	2012	12
12/31/2012	7	4308.761	2012	12
12/31/2012	8	4365.86	2012	12
12/31/2012	9	4438.656	2012	12
12/31/2012	10	4439.848	2012	12
12/31/2012	11	4377.461	2012	12
12/31/2012	12	4364.46	2012	12
12/31/2012	13	4366.559	2012	12
12/31/2012	14	4273.961	2012	12
12/31/2012	15	4229.854	2012	12
12/31/2012	16	4189.051	2012	12
12/31/2012	17	4296.861	2012	12
12/31/2012	18	4372.861	2012	12
12/31/2012	19	4227.161	2012	12
12/31/2012	20	4078.26	2012	12
12/31/2012	21	3928.958	2012	12
12/31/2012	22	3804.946	2012	12
12/31/2012	23	3662.461	2012	12
1/1/2013	0	3554.661	2013	1
1/1/2013	1	3478.76	2013	1
1/1/2013	2	3409.561	2013	1
1/1/2013	3	3343.161	2013	1
1/1/2013	4	3361.659	2013	1
1/1/2013	5	3408.659	2013	1
1/1/2013	6	3506.861	2013	1
1/1/2013	7	3577.261	2013	1
1/1/2013	8	3639.962	2013	1
1/1/2013	9	3752.752	2013	1
1/1/2013	10	3834.75	2013	1
1/1/2013	11	3910.257	2013	1
1/1/2013	12	3951.762	2013	1
1/1/2013	13	3929.962	2013	1
1/1/2013	14	3973.062	2013	1
1/1/2013	15	3971.363	2013	1
1/1/2013	16	4046.253	2013	1
1/1/2013	17	4269.152	2013	1
1/1/2013	18	4327.662	2013	1
1/1/2013	19	4327.16	2013	1
1/1/2013	20	4296.861	2013	1
1/1/2013	21	4182.461	2013	1
1/1/2013	22	4055.054	2013	1
1/1/2013	23	3903.05	2013	1
1/2/2013	0	3755.161	2013	1
1/2/2013	1	3747.161	2013	1
1/2/2013	2	3698.761	2013	1
1/2/2013	3	3731.261	2013	1
1/2/2013	4	3852.95	2013	1
1/2/2013	5	4115.952	2013	1
1/2/2013	6	4507.76	2013	1
1/2/2013	7	4853.461	2013	1
1/2/2013	8	4900.76	2013	1
1/2/2013	9	4907.159	2013	1
1/2/2013	10	4817.143	2013	1
1/2/2013	11	4730.758	2013	1
1/2/2013	12	4694.244	2013	1
1/2/2013	13	4626.158	2013	1

Day	Hr	Total	Year	Month
1/2/2013	14	4500.461	2013	1
1/2/2013	15	4437.263	2013	1
1/2/2013	16	4474.962	2013	1
1/2/2013	17	4729.061	2013	1
1/2/2013	18	4939.951	2013	1
1/2/2013	19	4969.551	2013	1
1/2/2013	20	4973.858	2013	1
1/2/2013	21	4850.459	2013	1
1/2/2013	22	4709.759	2013	1
1/2/2013	23	4533.559	2013	1
1/3/2013	0	4396.244	2013	1
1/3/2013	1	4290.556	2013	1
1/3/2013	2	4301.758	2013	1
1/3/2013	3	4282.958	2013	1
1/3/2013	4	4397.358	2013	1
1/3/2013	5	4587.849	2013	1
1/3/2013	6	4910.05	2013	1
1/3/2013	7	5263.558	2013	1
1/3/2013	8	5224.959	2013	1
1/3/2013	9	5139.06	2013	1
1/3/2013	10	4927.056	2013	1
1/3/2013	11	4744.849	2013	1
1/3/2013	12	4566.86	2013	1
1/3/2013	13	4531.062	2013	1
1/3/2013	14	4415.762	2013	1
1/3/2013	15	4344.762	2013	1
1/3/2013	16	4393.359	2013	1
1/3/2013	17	4571.446	2013	1
1/3/2013	18	4886.96	2013	1
1/3/2013	19	4971.759	2013	1
1/3/2013	20	4930.559	2013	1
1/3/2013	21	4898.759	2013	1
1/3/2013	22	4716.254	2013	1
1/3/2013	23	4512.547	2013	1
1/4/2013	0	4390.361	2013	1
1/4/2013	1	4292.105	2013	1
1/4/2013	2	4209.66	2013	1
1/4/2013	3	4181.46	2013	1
1/4/2013	4	4256.952	2013	1
1/4/2013	5	4390.85	2013	1
1/4/2013	6	4769.46	2013	1
1/4/2013	7	5077.26	2013	1
1/4/2013	8	5042.86	2013	1
1/4/2013	9	4991.834	2013	1
1/4/2013	10	4826.345	2013	1
1/4/2013	11	4705.358	2013	1
1/4/2013	12	4619.86	2013	1
1/4/2013	13	4526.061	2013	1
1/4/2013	14	4493.882	2013	1
1/4/2013	15	4451.162	2013	1
1/4/2013	16	4453.949	2013	1
1/4/2013	17	4593.256	2013	1
1/4/2013	18	4836.86	2013	1
1/4/2013	19	4841.46	2013	1
1/4/2013	20	4825.759	2013	1
1/4/2013	21	4753.46	2013	1
1/4/2013	22	4641.945	2013	1
1/4/2013	23	4464.255	2013	1
1/5/2013	0	4371.459	2013	1
1/5/2013	1	4251.059	2013	1
1/5/2013	2	4282.659	2013	1
1/5/2013	3	4250.655	2013	1
1/5/2013	4	4270.945	2013	1
1/5/2013	5	4340.459	2013	1

Day	Hr	Total	Year	Month
1/5/2013	6	4467.658	2013	1
1/5/2013	7	4639.359	2013	1
1/5/2013	8	4696.359	2013	1
1/5/2013	9	4665.469	2013	1
1/5/2013	10	4456.857	2013	1
1/5/2013	11	4270.662	2013	1
1/5/2013	12	4122.462	2013	1
1/5/2013	13	3943.863	2013	1
1/5/2013	14	3799.263	2013	1
1/5/2013	15	3840.557	2013	1
1/5/2013	16	3928.75	2013	1
1/5/2013	17	4088.962	2013	1
1/5/2013	18	4233.161	2013	1
1/5/2013	19	4170.553	2013	1
1/5/2013	20	4154.959	2013	1
1/5/2013	21	4039.961	2013	1
1/5/2013	22	3911.75	2013	1
1/5/2013	23	3757.055	2013	1
1/6/2013	0	3578.362	2013	1
1/6/2013	1	3516.161	2013	1
1/6/2013	2	3479.962	2013	1
1/6/2013	3	3400.561	2013	1
1/6/2013	4	3440.856	2013	1
1/6/2013	5	3514.931	2013	1
1/6/2013	6	3552.161	2013	1
1/6/2013	7	3693.762	2013	1
1/6/2013	8	3816.762	2013	1
1/6/2013	9	3948.162	2013	1
1/6/2013	10	3931.857	2013	1
1/6/2013	11	3957.149	2013	1
1/6/2013	12	3930.561	2013	1
1/6/2013	13	3951.561	2013	1
1/6/2013	14	3993.562	2013	1
1/6/2013	15	4029.66	2013	1
1/6/2013	16	4094.862	2013	1
1/6/2013	17	4339.545	2013	1
1/6/2013	18	4469.86	2013	1
1/6/2013	19	4473.261	2013	1
1/6/2013	20	4413.56	2013	1
1/6/2013	21	4247.46	2013	1
1/6/2013	22	4090.96	2013	1
1/6/2013	23	3983.946	2013	1
1/7/2013	0	3960.556	2013	1
1/7/2013	1	3936.759	2013	1
1/7/2013	2	3950.258	2013	1
1/7/2013	3	3992.059	2013	1
1/7/2013	4	4133.152	2013	1
1/7/2013	5	4406.547	2013	1
1/7/2013	6	4842.658	2013	1
1/7/2013	7	5202.759	2013	1
1/7/2013	8	5179.559	2013	1
1/7/2013	9	5039.759	2013	1
1/7/2013	10	4861.444	2013	1
1/7/2013	11	4653.761	2013	1
1/7/2013	12	4489.662	2013	1
1/7/2013	13	4389.661	2013	1
1/7/2013	14	4244.463	2013	1
1/7/2013	15	4148.363	2013	1
1/7/2013	16	4141.851	2013	1
1/7/2013	17	4338.057	2013	1
1/7/2013	18	4666.26	2013	1
1/7/2013	19	4783.96	2013	1
1/7/2013	20	4778.86	2013	1
1/7/2013	21	4693.359	2013	1

Day	Hr	Total	Year	Month
1/7/2013	22	4567.75	2013	1
1/7/2013	23	4349.551	2013	1
1/8/2013	0	4224.559	2013	1
1/8/2013	1	4206.259	2013	1
1/8/2013	2	4117.358	2013	1
1/8/2013	3	4163.86	2013	1
1/8/2013	4	4216.444	2013	1
1/8/2013	5	4398.356	2013	1
1/8/2013	6	4772.659	2013	1
1/8/2013	7	5076.358	2013	1
1/8/2013	8	5005.36	2013	1
1/8/2013	9	4848.474	2013	1
1/8/2013	10	4665.549	2013	1
1/8/2013	11	4417.862	2013	1
1/8/2013	12	4303.563	2013	1
1/8/2013	13	4247.563	2013	1
1/8/2013	14	4051.563	2013	1
1/8/2013	15	3996.863	2013	1
1/8/2013	16	3966.16	2013	1
1/8/2013	17	4160.35	2013	1
1/8/2013	18	4433.462	2013	1
1/8/2013	19	4448.362	2013	1
1/8/2013	20	4483.661	2013	1
1/8/2013	21	4334.561	2013	1
1/8/2013	22	4072.561	2013	1
1/8/2013	23	3925.954	2013	1
1/9/2013	0	3756.051	2013	1
1/9/2013	1	3646.661	2013	1
1/9/2013	2	3538.162	2013	1
1/9/2013	3	3486.361	2013	1
1/9/2013	4	3432.962	2013	1
1/9/2013	5	3632.362	2013	1
1/9/2013	6	3994.75	2013	1
1/9/2013	7	4289.658	2013	1
1/9/2013	8	4269.762	2013	1
1/9/2013	9	4269.663	2013	1
1/9/2013	10	4249.863	2013	1
1/9/2013	11	4215.863	2013	1
1/9/2013	12	4202.063	2013	1
1/9/2013	13	4109.061	2013	1
1/9/2013	14	3995.249	2013	1
1/9/2013	15	3900.764	2013	1
1/9/2013	16	3898.864	2013	1
1/9/2013	17	4061.863	2013	1
1/9/2013	18	4243.163	2013	1
1/9/2013	19	4248.163	2013	1
1/9/2013	20	4236.863	2013	1
1/9/2013	21	4134.062	2013	1
1/9/2013	22	3950.848	2013	1
1/9/2013	23	3717.16	2013	1
1/10/2013	0	3534.063	2013	1
1/10/2013	1	3446.862	2013	1
1/10/2013	2	3434.163	2013	1
1/10/2013	3	3363.662	2013	1
1/10/2013	4	3449.663	2013	1
1/10/2013	5	3535.357	2013	1
1/10/2013	6	3897.049	2013	1
1/10/2013	7	4203.362	2013	1
1/10/2013	8	4226.863	2013	1
1/10/2013	9	4229.562	2013	1
1/10/2013	10	4241.762	2013	1
1/10/2013	11	4219.863	2013	1
1/10/2013	12	4216.162	2013	1
1/10/2013	13	4189.247	2013	1

Day	Hr	Total	Year	Month
1/10/2013	14	4099.761	2013	1
1/10/2013	15	4050.85	2013	1
1/10/2013	16	4023.863	2013	1
1/10/2013	17	4112.163	2013	1
1/10/2013	18	4246.962	2013	1
1/10/2013	19	4203.163	2013	1
1/10/2013	20	4124.358	2013	1
1/10/2013	21	3977.049	2013	1
1/10/2013	22	3755.262	2013	1
1/10/2013	23	3504.163	2013	1
1/11/2013	0	3307.363	2013	1
1/11/2013	1	3149.362	2013	1
1/11/2013	2	3073.463	2013	1
1/11/2013	3	3047.862	2013	1
1/11/2013	4	3098.757	2013	1
1/11/2013	5	3244.952	2013	1
1/11/2013	6	3593.763	2013	1
1/11/2013	7	3900.963	2013	1
1/11/2013	8	3891.312	2013	1
1/11/2013	9	3881.063	2013	1
1/11/2013	10	3866.163	2013	1
1/11/2013	11	3822.664	2013	1
1/11/2013	12	3787.763	2013	1
1/11/2013	13	3757.051	2013	1
1/11/2013	14	3675.059	2013	1
1/11/2013	15	3592.364	2013	1
1/11/2013	16	3654.064	2013	1
1/11/2013	17	3635.864	2013	1
1/11/2013	18	3796.763	2013	1
1/11/2013	19	3791.663	2013	1
1/11/2013	20	3725.763	2013	1
1/11/2013	21	3573.763	2013	1
1/11/2013	22	3483.862	2013	1
1/11/2013	23	3238.25	2013	1
1/12/2013	0	3106.504	2013	1
1/12/2013	1	3028.862	2013	1
1/12/2013	2	2923.163	2013	1
1/12/2013	3	2846.563	2013	1
1/12/2013	4	2719.262	2013	1
1/12/2013	5	2867.563	2013	1
1/12/2013	6	2992.962	2013	1
1/12/2013	7	3087.162	2013	1
1/12/2013	8	3206.663	2013	1
1/12/2013	9	3335.561	2013	1
1/12/2013	10	3407.147	2013	1
1/12/2013	11	3476.463	2013	1
1/12/2013	12	3478.969	2013	1
1/12/2013	13	3414.168	2013	1
1/12/2013	14	3405.669	2013	1
1/12/2013	15	3333.768	2013	1
1/12/2013	16	3391.168	2013	1
1/12/2013	17	3484.967	2013	1
1/12/2013	18	3571.663	2013	1
1/12/2013	19	3543.262	2013	1
1/12/2013	20	3492.763	2013	1
1/12/2013	21	3337.362	2013	1
1/12/2013	22	3164.963	2013	1
1/12/2013	23	3004.552	2013	1
1/13/2013	0	2836.054	2013	1
1/13/2013	1	2662.463	2013	1
1/13/2013	2	2614.563	2013	1
1/13/2013	3	2630.567	2013	1
1/13/2013	4	2608.563	2013	1
1/13/2013	5	2618.263	2013	1

Day	Hr	Total	Year	Month
1/13/2013	6	2699.162	2013	1
1/13/2013	7	2778.467	2013	1
1/13/2013	8	2967.763	2013	1
1/13/2013	9	3101.163	2013	1
1/13/2013	10	3176.862	2013	1
1/13/2013	11	3289.151	2013	1
1/13/2013	12	3330.661	2013	1
1/13/2013	13	3394.864	2013	1
1/13/2013	14	3342.463	2013	1
1/13/2013	15	3348.762	2013	1
1/13/2013	16	3478.362	2013	1
1/13/2013	17	3644.462	2013	1
1/13/2013	18	3765.262	2013	1
1/13/2013	19	3766.874	2013	1
1/13/2013	20	3799.25	2013	1
1/13/2013	21	3690.048	2013	1
1/13/2013	22	3580.86	2013	1
1/13/2013	23	3453.761	2013	1
1/14/2013	0	3348.96	2013	1
1/14/2013	1	3320.361	2013	1
1/14/2013	2	3273.955	2013	1
1/14/2013	3	3359.747	2013	1
1/14/2013	4	3476.759	2013	1
1/14/2013	5	3809.46	2013	1
1/14/2013	6	4295.96	2013	1
1/14/2013	7	4732.159	2013	1
1/14/2013	8	4743.361	2013	1
1/14/2013	9	4806.145	2013	1
1/14/2013	10	4825.959	2013	1
1/14/2013	11	4734.961	2013	1
1/14/2013	12	4689.861	2013	1
1/14/2013	13	4726.163	2013	1
1/14/2013	14	4700.361	2013	1
1/14/2013	15	4697.547	2013	1
1/14/2013	16	4795.158	2013	1
1/14/2013	17	4957.961	2013	1
1/14/2013	18	5124.561	2013	1
1/14/2013	19	5100.16	2013	1
1/14/2013	20	5017.559	2013	1
1/14/2013	21	4872.144	2013	1
1/14/2013	22	4596.761	2013	1
1/14/2013	23	4383.06	2013	1
1/15/2013	0	4263.16	2013	1
1/15/2013	1	4217.238	2013	1
1/15/2013	2	4193.149	2013	1
1/15/2013	3	4154.853	2013	1
1/15/2013	4	4207.86	2013	1
1/15/2013	5	4430.659	2013	1
1/15/2013	6	4850.76	2013	1
1/15/2013	7	5112.951	2013	1
1/15/2013	8	5111.051	2013	1
1/15/2013	9	5109.26	2013	1
1/15/2013	10	5104.66	2013	1
1/15/2013	11	5055.06	2013	1
1/15/2013	12	4966.35	2013	1
1/15/2013	13	4930.954	2013	1
1/15/2013	14	4923.161	2013	1
1/15/2013	15	4910.161	2013	1
1/15/2013	16	4913.56	2013	1
1/15/2013	17	5045.255	2013	1
1/15/2013	18	5146.549	2013	1
1/15/2013	19	5072.661	2013	1
1/15/2013	20	5004.76	2013	1
1/15/2013	21	4816.26	2013	1

Day	Hr	Total	Year	Month
1/15/2013	22	4602.258	2013	1
1/15/2013	23	4325.946	2013	1
1/16/2013	0	4166.36	2013	1
1/16/2013	1	4053.961	2013	1
1/16/2013	2	3956.66	2013	1
1/16/2013	3	3929.961	2013	1
1/16/2013	4	3993.246	2013	1
1/16/2013	5	4165.057	2013	1
1/16/2013	6	4517.159	2013	1
1/16/2013	7	4819.959	2013	1
1/16/2013	8	4799.56	2013	1
1/16/2013	9	4852.654	2013	1
1/16/2013	10	4843.049	2013	1
1/16/2013	11	4879.86	2013	1
1/16/2013	12	4904.96	2013	1
1/16/2013	13	4849.86	2013	1
1/16/2013	14	4838.56	2013	1
1/16/2013	15	4706.35	2013	1
1/16/2013	16	4798.855	2013	1
1/16/2013	17	4871.161	2013	1
1/16/2013	18	5009.16	2013	1
1/16/2013	19	4941.961	2013	1
1/16/2013	20	4926.159	2013	1
1/16/2013	21	4721.844	2013	1
1/16/2013	22	4476.96	2013	1
1/16/2013	23	4313.259	2013	1
1/17/2013	0	4110.56	2013	1
1/17/2013	1	4001.46	2013	1
1/17/2013	2	3973.453	2013	1
1/17/2013	3	3907.949	2013	1
1/17/2013	4	3940.159	2013	1
1/17/2013	5	4161.561	2013	1
1/17/2013	6	4510.86	2013	1
1/17/2013	7	4812.76	2013	1
1/17/2013	8	4806.048	2013	1
1/17/2013	9	4831.356	2013	1
1/17/2013	10	4830.161	2013	1
1/17/2013	11	4779.562	2013	1
1/17/2013	12	4682.362	2013	1
1/17/2013	13	4593.563	2013	1
1/17/2013	14	4516.996	2013	1
1/17/2013	15	4392.06	2013	1
1/17/2013	16	4438.463	2013	1
1/17/2013	17	4525.962	2013	1
1/17/2013	18	4781.661	2013	1
1/17/2013	19	4760.662	2013	1
1/17/2013	20	4767.755	2013	1
1/17/2013	21	4716.25	2013	1
1/17/2013	22	4549.16	2013	1
1/17/2013	23	4384.961	2013	1
1/18/2013	0	4241.96	2013	1
1/18/2013	1	4184.16	2013	1
1/18/2013	2	4181.255	2013	1
1/18/2013	3	4210.447	2013	1
1/18/2013	4	4246.659	2013	1
1/18/2013	5	4492.66	2013	1
1/18/2013	6	4875.659	2013	1
1/18/2013	7	5185.859	2013	1
1/18/2013	8	5156.746	2013	1
1/18/2013	9	4980.657	2013	1
1/18/2013	10	4859.761	2013	1
1/18/2013	11	4653.862	2013	1
1/18/2013	12	4558.162	2013	1
1/18/2013	13	4404.062	2013	1

Day	Hr	Total	Year	Month
1/18/2013	14	4304.052	2013	1
1/18/2013	15	4149.957	2013	1
1/18/2013	16	4126.163	2013	1
1/18/2013	17	4282.363	2013	1
1/18/2013	18	4536.262	2013	1
1/18/2013	19	4529.66	2013	1
1/18/2013	20	4541.058	2013	1
1/18/2013	21	4458.446	2013	1
1/18/2013	22	4312.461	2013	1
1/18/2013	23	4124.061	2013	1
1/19/2013	0	4026.761	2013	1
1/19/2013	1	3899.661	2013	1
1/19/2013	2	3832.159	2013	1
1/19/2013	3	3770.946	2013	1
1/19/2013	4	3798.161	2013	1
1/19/2013	5	3894.562	2013	1
1/19/2013	6	3987.061	2013	1
1/19/2013	7	4134.261	2013	1
1/19/2013	8	4226.257	2013	1
1/19/2013	9	4171.549	2013	1
1/19/2013	10	4067.362	2013	1
1/19/2013	11	3930.863	2013	1
1/19/2013	12	3788.263	2013	1
1/19/2013	13	3659.263	2013	1
1/19/2013	14	3502.042	2013	1
1/19/2013	15	3481.862	2013	1
1/19/2013	16	3448.553	2013	1
1/19/2013	17	3577.264	2013	1
1/19/2013	18	3856.162	2013	1
1/19/2013	19	3885.863	2013	1
1/19/2013	20	3833.062	2013	1
1/19/2013	21	3724.662	2013	1
1/19/2013	22	3573.959	2013	1
1/19/2013	23	3477.748	2013	1
1/20/2013	0	3383.562	2013	1
1/20/2013	1	3334.263	2013	1
1/20/2013	2	3259.861	2013	1
1/20/2013	3	3252.362	2013	1
1/20/2013	4	3295.261	2013	1
1/20/2013	5	3354.46	2013	1
1/20/2013	6	3470.346	2013	1
1/20/2013	7	3648.761	2013	1
1/20/2013	8	3759.763	2013	1
1/20/2013	9	3779.962	2013	1
1/20/2013	10	3763.662	2013	1
1/20/2013	11	3689.163	2013	1
1/20/2013	12	3595.463	2013	1
1/20/2013	13	3546.147	2013	1
1/20/2013	14	3454.162	2013	1
1/20/2013	15	3421.964	2013	1
1/20/2013	16	3434.863	2013	1
1/20/2013	17	3588.863	2013	1
1/20/2013	18	3971.763	2013	1
1/20/2013	19	4107.761	2013	1
1/20/2013	20	4100.848	2013	1
1/20/2013	21	4093.456	2013	1
1/20/2013	22	4052.96	2013	1
1/20/2013	23	3927.661	2013	1
1/21/2013	0	3874.86	2013	1
1/21/2013	1	3863.661	2013	1
1/21/2013	2	3878.951	2013	1
1/21/2013	3	3930.951	2013	1
1/21/2013	4	4034.759	2013	1
1/21/2013	5	4216.458	2013	1

Day	Hr	Total	Year	Month
1/21/2013	6	4468.959	2013	1
1/21/2013	7	4775.459	2013	1
1/21/2013	8	4903.845	2013	1
1/21/2013	9	4921.053	2013	1
1/21/2013	10	4893.759	2013	1
1/21/2013	11	4771.758	2013	1
1/21/2013	12	4775.758	2013	1
1/21/2013	13	4788.155	2013	1
1/21/2013	14	4652.047	2013	1
1/21/2013	15	4614.361	2013	1
1/21/2013	16	4654.359	2013	1
1/21/2013	17	4883.458	2013	1
1/21/2013	18	5247.158	2013	1
1/21/2013	19	5394.243	2013	1
1/21/2013	20	5352.357	2013	1
1/21/2013	21	5303.659	2013	1
1/21/2013	22	5081.458	2013	1
1/21/2013	23	4978.957	2013	1
1/22/2013	0	4900.742	2013	1
1/22/2013	1	4877.358	2013	1
1/22/2013	2	4860.257	2013	1
1/22/2013	3	4895.857	2013	1
1/22/2013	4	4979.149	2013	1
1/22/2013	5	5200.348	2013	1
1/22/2013	6	5596.158	2013	1
1/22/2013	7	5907.257	2013	1
1/22/2013	8	5888.956	2013	1
1/22/2013	9	5759.041	2013	1
1/22/2013	10	5638.957	2013	1
1/22/2013	11	5483.857	2013	1
1/22/2013	12	5385.458	2013	1
1/22/2013	13	5246.204	2013	1
1/22/2013	14	5142.948	2013	1
1/22/2013	15	5130.258	2013	1
1/22/2013	16	5230.759	2013	1
1/22/2013	17	5377.058	2013	1
1/22/2013	18	5613.446	2013	1
1/22/2013	19	5685.948	2013	1
1/22/2013	20	5630.757	2013	1
1/22/2013	21	5538.956	2013	1
1/22/2013	22	5301.658	2013	1
1/22/2013	23	5054.641	2013	1
1/23/2013	0	4919.855	2013	1
1/23/2013	1	4857.057	2013	1
1/23/2013	2	4760.357	2013	1
1/23/2013	3	4791.55	2013	1
1/23/2013	4	4940.346	2013	1
1/23/2013	5	5103.157	2013	1
1/23/2013	6	5465.257	2013	1
1/23/2013	7	5747.757	2013	1
1/23/2013	8	5660.943	2013	1
1/23/2013	9	5597.257	2013	1
1/23/2013	10	5480.359	2013	1
1/23/2013	11	5302.36	2013	1
1/23/2013	12	5143.256	2013	1
1/23/2013	13	4924.149	2013	1
1/23/2013	14	4807.361	2013	1
1/23/2013	15	4650.661	2013	1
1/23/2013	16	4679.461	2013	1
1/23/2013	17	4800.761	2013	1
1/23/2013	18	5048.945	2013	1
1/23/2013	19	5084.258	2013	1
1/23/2013	20	5072.359	2013	1
1/23/2013	21	4925.659	2013	1

Day	Hr	Total	Year	Month
1/23/2013	22	4728.758	2013	1
1/23/2013	23	4488.352	2013	1
1/24/2013	0	4350.75	2013	1
1/24/2013	1	4298.059	2013	1
1/24/2013	2	4282.561	2013	1
1/24/2013	3	4299.76	2013	1
1/24/2013	4	4436.954	2013	1
1/24/2013	5	4719.092	2013	1
1/24/2013	6	5141.859	2013	1
1/24/2013	7	5469.76	2013	1
1/24/2013	8	5452.158	2013	1
1/24/2013	9	5419.247	2013	1
1/24/2013	10	5315.788	2013	1
1/24/2013	11	5165.093	2013	1
1/24/2013	12	5084.79	2013	1
1/24/2013	13	5034.66	2013	1
1/24/2013	14	4902.846	2013	1
1/24/2013	15	4870.259	2013	1
1/24/2013	16	4866.061	2013	1
1/24/2013	17	5030.76	2013	1
1/24/2013	18	5363.56	2013	1
1/24/2013	19	5392.643	2013	1
1/24/2013	20	5419.258	2013	1
1/24/2013	21	5259.16	2013	1
1/24/2013	22	5033.159	2013	1
1/24/2013	23	4839.65	2013	1
1/25/2013	0	4718.251	2013	1
1/25/2013	1	4615.454	2013	1
1/25/2013	2	4551.24	2013	1
1/25/2013	3	4512.24	2013	1
1/25/2013	4	4532.14	2013	1
1/25/2013	5	4687.139	2013	1
1/25/2013	6	4953.14	2013	1
1/25/2013	7	5205.839	2013	1
1/25/2013	8	5273.34	2013	1
1/25/2013	9	5290.438	2013	1
1/25/2013	10	5367.024	2013	1
1/25/2013	11	5346.542	2013	1
1/25/2013	12	5377.742	2013	1
1/25/2013	13	5271.248	2013	1
1/25/2013	14	5185.559	2013	1
1/25/2013	15	5098.06	2013	1
1/25/2013	16	5074.159	2013	1
1/25/2013	17	5104.36	2013	1
1/25/2013	18	5175.643	2013	1
1/25/2013	19	5127.459	2013	1
1/25/2013	20	5050.354	2013	1
1/25/2013	21	4869.239	2013	1
1/25/2013	22	4684.039	2013	1
1/25/2013	23	4528.039	2013	1
1/26/2013	0	4412.339	2013	1
1/26/2013	1	4386.939	2013	1
1/26/2013	2	4299.74	2013	1
1/26/2013	3	4294.638	2013	1
1/26/2013	4	4328.439	2013	1
1/26/2013	5	4341.738	2013	1
1/26/2013	6	4528.338	2013	1
1/26/2013	7	4662.138	2013	1
1/26/2013	8	4790.039	2013	1
1/26/2013	9	4822.34	2013	1
1/26/2013	10	4664.741	2013	1
1/26/2013	11	4568.041	2013	1
1/26/2013	12	4396.742	2013	1
1/26/2013	13	4255.242	2013	1

Day	Hr	Total	Year	Month
1/26/2013	14	4093.543	2013	1
1/26/2013	15	3977.143	2013	1
1/26/2013	16	3965.743	2013	1
1/26/2013	17	4108.242	2013	1
1/26/2013	18	4429.341	2013	1
1/26/2013	19	4513.94	2013	1
1/26/2013	20	4553.34	2013	1
1/26/2013	21	4483.941	2013	1
1/26/2013	22	4385.54	2013	1
1/26/2013	23	4245.24	2013	1
1/27/2013	0	4178.24	2013	1
1/27/2013	1	4085.197	2013	1
1/27/2013	2	4126.539	2013	1
1/27/2013	3	4107.64	2013	1
1/27/2013	4	4116.64	2013	1
1/27/2013	5	4247.439	2013	1
1/27/2013	6	4359.039	2013	1
1/27/2013	7	4496.947	2013	1
1/27/2013	8	4530.14	2013	1
1/27/2013	9	4545.541	2013	1
1/27/2013	10	4373.941	2013	1
1/27/2013	11	4209.141	2013	1
1/27/2013	12	4016.242	2013	1
1/27/2013	13	3996.443	2013	1
1/27/2013	14	3883.242	2013	1
1/27/2013	15	3866.043	2013	1
1/27/2013	16	3853.043	2013	1
1/27/2013	17	3983.943	2013	1
1/27/2013	18	4168.241	2013	1
1/27/2013	19	4139.041	2013	1
1/27/2013	20	4100.542	2013	1
1/27/2013	21	3945.041	2013	1
1/27/2013	22	3742.842	2013	1
1/27/2013	23	3536.742	2013	1
1/28/2013	0	3409.543	2013	1
1/28/2013	1	3321.843	2013	1
1/28/2013	2	3263.343	2013	1
1/28/2013	3	3274.142	2013	1
1/28/2013	4	3359.344	2013	1
1/28/2013	5	3570.142	2013	1
1/28/2013	6	3950.444	2013	1
1/28/2013	7	4235.443	2013	1
1/28/2013	8	4211.743	2013	1
1/28/2013	9	4187.443	2013	1
1/28/2013	10	4170.044	2013	1
1/28/2013	11	4112.046	2013	1
1/28/2013	12	4168.659	2013	1
1/28/2013	13	4124.763	2013	1
1/28/2013	14	4068.562	2013	1
1/28/2013	15	4024.062	2013	1
1/28/2013	16	3996.263	2013	1
1/28/2013	17	4060.062	2013	1
1/28/2013	18	4183.962	2013	1
1/28/2013	19	4128.863	2013	1
1/28/2013	20	4045.553	2013	1
1/28/2013	21	3882.152	2013	1
1/28/2013	22	3649.963	2013	1
1/28/2013	23	3416.662	2013	1
1/29/2013	0	3245.263	2013	1
1/29/2013	1	3148.662	2013	1
1/29/2013	2	3059.363	2013	1
1/29/2013	3	3024.862	2013	1
1/29/2013	4	3058.963	2013	1
1/29/2013	5	3255.649	2013	1

Day	Hr	Total	Year	Month
1/29/2013	6	3630.958	2013	1
1/29/2013	7	3916.462	2013	1
1/29/2013	8	3872.163	2013	1
1/29/2013	9	3900.063	2013	1
1/29/2013	10	3875.363	2013	1
1/29/2013	11	3846.363	2013	1
1/29/2013	12	3846.663	2013	1
1/29/2013	13	3797.563	2013	1
1/29/2013	14	3761.653	2013	1
1/29/2013	15	3711.256	2013	1
1/29/2013	16	3643.163	2013	1
1/29/2013	17	3702.563	2013	1
1/29/2013	18	3916.563	2013	1
1/29/2013	19	3895.963	2013	1
1/29/2013	20	3891.163	2013	1
1/29/2013	21	3714.462	2013	1
1/29/2013	22	3545.964	2013	1
1/29/2013	23	3334.663	2013	1
1/30/2013	0	3083.56	2013	1
1/30/2013	1	2945.248	2013	1
1/30/2013	2	2927.663	2013	1
1/30/2013	3	2864.264	2013	1
1/30/2013	4	2833.863	2013	1
1/30/2013	5	2991.762	2013	1
1/30/2013	6	3311.563	2013	1
1/30/2013	7	3652.263	2013	1
1/30/2013	8	3736.801	2013	1
1/30/2013	9	3763.462	2013	1
1/30/2013	10	3820.254	2013	1
1/30/2013	11	3876.253	2013	1
1/30/2013	12	3961.523	2013	1
1/30/2013	13	3959.763	2013	1
1/30/2013	14	3947.363	2013	1
1/30/2013	15	3898.163	2013	1
1/30/2013	16	3880.063	2013	1
1/30/2013	17	4037.961	2013	1
1/30/2013	18	4220.655	2013	1
1/30/2013	19	4198.647	2013	1
1/30/2013	20	4217.059	2013	1
1/30/2013	21	4189.059	2013	1
1/30/2013	22	4088.658	2013	1
1/30/2013	23	3973.359	2013	1
1/31/2013	0	3937.756	2013	1
1/31/2013	1	3852.741	2013	1
1/31/2013	2	3845.158	2013	1
1/31/2013	3	3915.957	2013	1
1/31/2013	4	3957.458	2013	1
1/31/2013	5	4183.157	2013	1
1/31/2013	6	4615.248	2013	1
1/31/2013	7	4960.35	2013	1
1/31/2013	8	5020.458	2013	1
1/31/2013	9	5023.359	2013	1
1/31/2013	10	5046.159	2013	1
1/31/2013	11	4980.158	2013	1
1/31/2013	12	5034.644	2013	1
1/31/2013	13	4852.859	2013	1
1/31/2013	14	4813.659	2013	1
1/31/2013	15	4703.56	2013	1
1/31/2013	16	4708.26	2013	1
1/31/2013	17	4735.751	2013	1
1/31/2013	18	4953.85	2013	1
1/31/2013	19	5024.259	2013	1
1/31/2013	20	4926.859	2013	1
1/31/2013	21	4869.159	2013	1

Day	Hr	Total	Year	Month
1/31/2013	22	4691.356	2013	1
1/31/2013	23	4672.442	2013	1
2/1/2013	0	4677.258	2013	2
2/1/2013	1	4716.058	2013	2
2/1/2013	2	4757.359	2013	2
2/1/2013	3	4862.547	2013	2
2/1/2013	4	4990.148	2013	2
2/1/2013	5	5221.156	2013	2
2/1/2013	6	5558.157	2013	2
2/1/2013	7	5845.253	2013	2
2/1/2013	8	5901.342	2013	2
2/1/2013	9	5818.856	2013	2
2/1/2013	10	5744.257	2013	2
2/1/2013	11	5578.756	2013	2
2/1/2013	12	5486.945	2013	2
2/1/2013	13	5341.853	2013	2
2/1/2013	14	5112.658	2013	2
2/1/2013	15	4990.76	2013	2
2/1/2013	16	4889.356	2013	2
2/1/2013	17	5044.344	2013	2
2/1/2013	18	5356.858	2013	2
2/1/2013	19	5465.357	2013	2
2/1/2013	20	5446.256	2013	2
2/1/2013	21	5419.547	2013	2
2/1/2013	22	5241.95	2013	2
2/1/2013	23	5059.957	2013	2
2/2/2013	0	4900.878	2013	2
2/2/2013	1	4742.258	2013	2
2/2/2013	2	4649.742	2013	2
2/2/2013	3	4597.158	2013	2
2/2/2013	4	4548.259	2013	2
2/2/2013	5	4540.858	2013	2
2/2/2013	6	4627.649	2013	2
2/2/2013	7	4795.229	2013	2
2/2/2013	8	4877.46	2013	2
2/2/2013	9	4916.459	2013	2
2/2/2013	10	4967.457	2013	2
2/2/2013	11	4836.446	2013	2
2/2/2013	12	4684.16	2013	2
2/2/2013	13	4583.26	2013	2
2/2/2013	14	4492.46	2013	2
2/2/2013	15	4439.56	2013	2
2/2/2013	16	4412.745	2013	2
2/2/2013	17	4465.858	2013	2
2/2/2013	18	4608.96	2013	2
2/2/2013	19	4611.659	2013	2
2/2/2013	20	4564.86	2013	2
2/2/2013	21	4488.749	2013	2
2/2/2013	22	4253.953	2013	2
2/2/2013	23	4086.959	2013	2
2/3/2013	0	3921.759	2013	2
2/3/2013	1	3891.959	2013	2
2/3/2013	2	3826.188	2013	2
2/3/2013	3	3826.248	2013	2
2/3/2013	4	3846.658	2013	2
2/3/2013	5	3907.959	2013	2
2/3/2013	6	4018.259	2013	2
2/3/2013	7	4172.955	2013	2
2/3/2013	8	4298.845	2013	2
2/3/2013	9	4376.459	2013	2
2/3/2013	10	4495.26	2013	2
2/3/2013	11	4458.759	2013	2
2/3/2013	12	4488.26	2013	2
2/3/2013	13	4500.343	2013	2

Day	Hr	Total	Year	Month
2/3/2013	14	4506.458	2013	2
2/3/2013	15	4537.76	2013	2
2/3/2013	16	4517.16	2013	2
2/3/2013	17	4638.559	2013	2
2/3/2013	18	4721.745	2013	2
2/3/2013	19	4677.255	2013	2
2/3/2013	20	4646.458	2013	2
2/3/2013	21	4595.458	2013	2
2/3/2013	22	4443.658	2013	2
2/3/2013	23	4362.346	2013	2
2/4/2013	0	4305.051	2013	2
2/4/2013	1	4262.412	2013	2
2/4/2013	2	4296.258	2013	2
2/4/2013	3	4387.957	2013	2
2/4/2013	4	4501.445	2013	2
2/4/2013	5	4781.652	2013	2
2/4/2013	6	5117.759	2013	2
2/4/2013	7	5386.259	2013	2
2/4/2013	8	5387.861	2013	2
2/4/2013	9	5274.046	2013	2
2/4/2013	10	5127.059	2013	2
2/4/2013	11	4943.562	2013	2
2/4/2013	12	4816.463	2013	2
2/4/2013	13	4685.862	2013	2
2/4/2013	14	4605.651	2013	2
2/4/2013	15	4546.758	2013	2
2/4/2013	16	4538.162	2013	2
2/4/2013	17	4622.562	2013	2
2/4/2013	18	4752.361	2013	2
2/4/2013	19	4776.46	2013	2
2/4/2013	20	4644.448	2013	2
2/4/2013	21	4441.358	2013	2
2/4/2013	22	4218.46	2013	2
2/4/2013	23	3975.261	2013	2
2/5/2013	0	3815.861	2013	2
2/5/2013	1	3722.061	2013	2
2/5/2013	2	3689.549	2013	2
2/5/2013	3	3672.856	2013	2
2/5/2013	4	3677.861	2013	2
2/5/2013	5	3844.877	2013	2
2/5/2013	6	4234.162	2013	2
2/5/2013	7	4482.86	2013	2
2/5/2013	8	4481.65	2013	2
2/5/2013	9	4507.654	2013	2
2/5/2013	10	4478.861	2013	2
2/5/2013	11	4395.962	2013	2
2/5/2013	12	4313.362	2013	2
2/5/2013	13	4196.462	2013	2
2/5/2013	14	4093.257	2013	2
2/5/2013	15	4023.252	2013	2
2/5/2013	16	4019.163	2013	2
2/5/2013	17	4051.462	2013	2
2/5/2013	18	4252.962	2013	2
2/5/2013	19	4406.561	2013	2
2/5/2013	20	4378.961	2013	2
2/5/2013	21	4340.154	2013	2
2/5/2013	22	4110.552	2013	2
2/5/2013	23	3935.861	2013	2
2/6/2013	0	3762.462	2013	2
2/6/2013	1	3747.662	2013	2
2/6/2013	2	3747.261	2013	2
2/6/2013	3	3811.061	2013	2
2/6/2013	4	3898.944	2013	2
2/6/2013	5	4114.155	2013	2

Day	Hr	Total	Year	Month
2/6/2013	6	4621.861	2013	2
2/6/2013	7	4886.159	2013	2
2/6/2013	8	4878.961	2013	2
2/6/2013	9	4762.86	2013	2
2/6/2013	10	4620.848	2013	2
2/6/2013	11	4440.659	2013	2
2/6/2013	12	4354.361	2013	2
2/6/2013	13	4266.463	2013	2
2/6/2013	14	4145.862	2013	2
2/6/2013	15	3995.364	2013	2
2/6/2013	16	3960.06	2013	2
2/6/2013	17	4035.749	2013	2
2/6/2013	18	4356.362	2013	2
2/6/2013	19	4492.162	2013	2
2/6/2013	20	4476.561	2013	2
2/6/2013	21	4393.261	2013	2
2/6/2013	22	4258.36	2013	2
2/6/2013	23	4039.549	2013	2
2/7/2013	0	3888.556	2013	2
2/7/2013	1	3818.861	2013	2
2/7/2013	2	3759.36	2013	2
2/7/2013	3	3670.96	2013	2
2/7/2013	4	3752.561	2013	2
2/7/2013	5	3966.05	2013	2
2/7/2013	6	4315.455	2013	2
2/7/2013	7	4574.36	2013	2
2/7/2013	8	4523.761	2013	2
2/7/2013	9	4396.761	2013	2
2/7/2013	10	4265.561	2013	2
2/7/2013	11	4101.154	2013	2
2/7/2013	12	4043.854	2013	2
2/7/2013	13	3966.864	2013	2
2/7/2013	14	3879.263	2013	2
2/7/2013	15	3790.963	2013	2
2/7/2013	16	3753.164	2013	2
2/7/2013	17	3722.963	2013	2
2/7/2013	18	3935.763	2013	2
2/7/2013	19	4086.454	2013	2
2/7/2013	20	4061.054	2013	2
2/7/2013	21	3941.854	2013	2
2/7/2013	22	3768.562	2013	2
2/7/2013	23	3553.263	2013	2
2/8/2013	0	3417.163	2013	2
2/8/2013	1	3286.062	2013	2
2/8/2013	2	3232.063	2013	2
2/8/2013	3	3157.086	2013	2
2/8/2013	4	3258.055	2013	2
2/8/2013	5	3460.453	2013	2
2/8/2013	6	3859.562	2013	2
2/8/2013	7	4192.362	2013	2
2/8/2013	8	4258.862	2013	2
2/8/2013	9	4365.963	2013	2
2/8/2013	10	4412.162	2013	2
2/8/2013	11	4451.555	2013	2
2/8/2013	12	4462.451	2013	2
2/8/2013	13	4484.462	2013	2
2/8/2013	14	4547.562	2013	2
2/8/2013	15	4462.162	2013	2
2/8/2013	16	4470.462	2013	2
2/8/2013	17	4587.562	2013	2
2/8/2013	18	4693.852	2013	2
2/8/2013	19	4661.152	2013	2
2/8/2013	20	4660.362	2013	2
2/8/2013	21	4511.36	2013	2

Day	Hr	Total	Year	Month
2/8/2013	22	4323.16	2013	2
2/8/2013	23	4163.86	2013	2
2/9/2013	0	4008.559	2013	2
2/9/2013	1	3888.044	2013	2
2/9/2013	2	3798.361	2013	2
2/9/2013	3	3779.961	2013	2
2/9/2013	4	3797.461	2013	2
2/9/2013	5	3917.46	2013	2
2/9/2013	6	4172.659	2013	2
2/9/2013	7	4315.544	2013	2
2/9/2013	8	4365.661	2013	2
2/9/2013	9	4319.662	2013	2
2/9/2013	10	4282.561	2013	2
2/9/2013	11	4112.963	2013	2
2/9/2013	12	3934.062	2013	2
2/9/2013	13	3775.252	2013	2
2/9/2013	14	3607.258	2013	2
2/9/2013	15	3547.963	2013	2
2/9/2013	16	3557.864	2013	2
2/9/2013	17	3632.163	2013	2
2/9/2013	18	3953.362	2013	2
2/9/2013	19	4056.761	2013	2
2/9/2013	20	4077.552	2013	2
2/9/2013	21	4003.154	2013	2
2/9/2013	22	3911.561	2013	2
2/9/2013	23	3805.86	2013	2
2/10/2013	0	3669.631	2013	2
2/10/2013	1	3612.86	2013	2
2/10/2013	2	3507.36	2013	2
2/10/2013	3	3445.045	2013	2
2/10/2013	4	3435.76	2013	2
2/10/2013	5	3478.561	2013	2
2/10/2013	6	3494.061	2013	2
2/10/2013	7	3645.661	2013	2
2/10/2013	8	3737.261	2013	2
2/10/2013	9	3764.552	2013	2
2/10/2013	10	3813.453	2013	2
2/10/2013	11	3710.162	2013	2
2/10/2013	12	3607.263	2013	2
2/10/2013	13	3476.364	2013	2
2/10/2013	14	3462.762	2013	2
2/10/2013	15	3508.563	2013	2
2/10/2013	16	3568.758	2013	2
2/10/2013	17	3648.15	2013	2
2/10/2013	18	3821.563	2013	2
2/10/2013	19	3859.162	2013	2
2/10/2013	20	3864.362	2013	2
2/10/2013	21	3728.839	2013	2
2/10/2013	22	3475.262	2013	2
2/10/2013	23	3223.663	2013	2
2/11/2013	0	3064.45	2013	2
2/11/2013	1	3002.458	2013	2
2/11/2013	2	3016.762	2013	2
2/11/2013	3	2986.463	2013	2
2/11/2013	4	3071.762	2013	2
2/11/2013	5	3283.263	2013	2
2/11/2013	6	3679.762	2013	2
2/11/2013	7	3976.059	2013	2
2/11/2013	8	3978.446	2013	2
2/11/2013	9	4003.061	2013	2
2/11/2013	10	4011.961	2013	2
2/11/2013	11	4001.162	2013	2
2/11/2013	12	4038.261	2013	2
2/11/2013	13	4047.362	2013	2

Day	Hr	Total	Year	Month
2/11/2013	14	3997.163	2013	2
2/11/2013	15	3891.247	2013	2
2/11/2013	16	3857.661	2013	2
2/11/2013	17	3873.062	2013	2
2/11/2013	18	4178.862	2013	2
2/11/2013	19	4320.762	2013	2
2/11/2013	20	4341.861	2013	2
2/11/2013	21	4223.261	2013	2
2/11/2013	22	4069.95	2013	2
2/11/2013	23	3835.254	2013	2
2/12/2013	0	3728.461	2013	2
2/12/2013	1	3675.56	2013	2
2/12/2013	2	3609.06	2013	2
2/12/2013	3	3667.56	2013	2
2/12/2013	4	3703.86	2013	2
2/12/2013	5	3975.343	2013	2
2/12/2013	6	4403.858	2013	2
2/12/2013	7	4691.86	2013	2
2/12/2013	8	4654.129	2013	2
2/12/2013	9	4452.862	2013	2
2/12/2013	10	4309.862	2013	2
2/12/2013	11	4147.862	2013	2
2/12/2013	12	4097.765	2013	2
2/12/2013	13	4024.958	2013	2
2/12/2013	14	3951.458	2013	2
2/12/2013	15	3904.656	2013	2
2/12/2013	16	3810.654	2013	2
2/12/2013	17	3953.151	2013	2
2/12/2013	18	4216.651	2013	2
2/12/2013	19	4328.55	2013	2
2/12/2013	20	4263.547	2013	2
2/12/2013	21	4219.143	2013	2
2/12/2013	22	4030.943	2013	2
2/12/2013	23	3863.943	2013	2
2/13/2013	0	3704.543	2013	2
2/13/2013	1	3595.044	2013	2
2/13/2013	2	3522.043	2013	2
2/13/2013	3	3486.543	2013	2
2/13/2013	4	3527.428	2013	2
2/13/2013	5	3725.227	2013	2
2/13/2013	6	4127.828	2013	2
2/13/2013	7	4444.732	2013	2
2/13/2013	8	4449.943	2013	2
2/13/2013	9	4490.237	2013	2
2/13/2013	10	4543.927	2013	2
2/13/2013	11	4538.227	2013	2
2/13/2013	12	4555.227	2013	2
2/13/2013	13	4544.127	2013	2
2/13/2013	14	4460.952	2013	2
2/13/2013	15	4410.044	2013	2
2/13/2013	16	4327.543	2013	2
2/13/2013	17	4378.243	2013	2
2/13/2013	18	4509.242	2013	2
2/13/2013	19	4647.142	2013	2
2/13/2013	20	4698.242	2013	2
2/13/2013	21	4546.134	2013	2
2/13/2013	22	4420.526	2013	2
2/13/2013	23	4149.242	2013	2
2/14/2013	0	4040.043	2013	2
2/14/2013	1	3964.242	2013	2
2/14/2013	2	3923.942	2013	2
2/14/2013	3	3951.142	2013	2
2/14/2013	4	3984.543	2013	2
2/14/2013	5	4179.042	2013	2

Day	Hr	Total	Year	Month
2/14/2013	6	4562.442	2013	2
2/14/2013	7	4803.825	2013	2
2/14/2013	8	4737.937	2013	2
2/14/2013	9	4650.743	2013	2
2/14/2013	10	4542.143	2013	2
2/14/2013	11	4332.144	2013	2
2/14/2013	12	4198.849	2013	2
2/14/2013	13	4097.563	2013	2
2/14/2013	14	3973.754	2013	2
2/14/2013	15	3773.149	2013	2
2/14/2013	16	3733.263	2013	2
2/14/2013	17	3751.763	2013	2
2/14/2013	18	4013.263	2013	2
2/14/2013	19	4123.862	2013	2
2/14/2013	20	4153.861	2013	2
2/14/2013	21	4088.162	2013	2
2/14/2013	22	3943.162	2013	2
2/14/2013	23	3781.662	2013	2
2/15/2013	0	3700.446	2013	2
2/15/2013	1	3584.56	2013	2
2/15/2013	2	3535.861	2013	2
2/15/2013	3	3551.162	2013	2
2/15/2013	4	3587.561	2013	2
2/15/2013	5	3806.561	2013	2
2/15/2013	6	4184.161	2013	2
2/15/2013	7	4486.657	2013	2
2/15/2013	8	4461.649	2013	2
2/15/2013	9	4454.562	2013	2
2/15/2013	10	4417.461	2013	2
2/15/2013	11	4366.325	2013	2
2/15/2013	12	4402.362	2013	2
2/15/2013	13	4384.262	2013	2
2/15/2013	14	4337.163	2013	2
2/15/2013	15	4221.551	2013	2
2/15/2013	16	4188.257	2013	2
2/15/2013	17	4219.462	2013	2
2/15/2013	18	4375.562	2013	2
2/15/2013	19	4501.761	2013	2
2/15/2013	20	4520.961	2013	2
2/15/2013	21	4436.261	2013	2
2/15/2013	22	4335.45	2013	2
2/15/2013	23	4199.152	2013	2
2/16/2013	0	4079.961	2013	2
2/16/2013	1	4039.06	2013	2
2/16/2013	2	4011.059	2013	2
2/16/2013	3	3982.159	2013	2
2/16/2013	4	4024.153	2013	2
2/16/2013	5	4094.946	2013	2
2/16/2013	6	4310.458	2013	2
2/16/2013	7	4471.959	2013	2
2/16/2013	8	4549.96	2013	2
2/16/2013	9	4574.261	2013	2
2/16/2013	10	4475.853	2013	2
2/16/2013	11	4365.452	2013	2
2/16/2013	12	4347.96	2013	2
2/16/2013	13	4250.362	2013	2
2/16/2013	14	4175.8	2013	2
2/16/2013	15	4104.523	2013	2
2/16/2013	16	4096.156	2013	2
2/16/2013	17	4221.049	2013	2
2/16/2013	18	4480.661	2013	2
2/16/2013	19	4622.26	2013	2
2/16/2013	20	4617.26	2013	2
2/16/2013	21	4565.859	2013	2

Day	Hr	Total	Year	Month
2/16/2013	22	4446.95	2013	2
2/16/2013	23	4295.251	2013	2
2/17/2013	0	4153.358	2013	2
2/17/2013	1	4064.958	2013	2
2/17/2013	2	4025.458	2013	2
2/17/2013	3	4055.256	2013	2
2/17/2013	4	4047.242	2013	2
2/17/2013	5	4175.058	2013	2
2/17/2013	6	4298.058	2013	2
2/17/2013	7	4439.158	2013	2
2/17/2013	8	4508.659	2013	2
2/17/2013	9	4464.047	2013	2
2/17/2013	10	4339.356	2013	2
2/17/2013	11	4158.461	2013	2
2/17/2013	12	4056.961	2013	2
2/17/2013	13	3903.462	2013	2
2/17/2013	14	3759.563	2013	2
2/17/2013	15	3641.452	2013	2
2/17/2013	16	3654.256	2013	2
2/17/2013	17	3811.463	2013	2
2/17/2013	18	4113.261	2013	2
2/17/2013	19	4364.56	2013	2
2/17/2013	20	4411.059	2013	2
2/17/2013	21	4350.553	2013	2
2/17/2013	22	4255.948	2013	2
2/17/2013	23	4123.759	2013	2
2/18/2013	0	4029.559	2013	2
2/18/2013	1	4012.659	2013	2
2/18/2013	2	4024.459	2013	2
2/18/2013	3	4064.448	2013	2
2/18/2013	4	4162.453	2013	2
2/18/2013	5	4350.259	2013	2
2/18/2013	6	4659.337	2013	2
2/18/2013	7	4864.359	2013	2
2/18/2013	8	4845.657	2013	2
2/18/2013	9	4684.546	2013	2
2/18/2013	10	4523.963	2013	2
2/18/2013	11	4321.862	2013	2
2/18/2013	12	4260.763	2013	2
2/18/2013	13	4086.763	2013	2
2/18/2013	14	3983.163	2013	2
2/18/2013	15	3850.163	2013	2
2/18/2013	16	3863.948	2013	2
2/18/2013	17	3894.663	2013	2
2/18/2013	18	4172.4	2013	2
2/18/2013	19	4274.625	2013	2
2/18/2013	20	4249.862	2013	2
2/18/2013	21	4098.463	2013	2
2/18/2013	22	3929.062	2013	2
2/18/2013	23	3691.751	2013	2
2/19/2013	0	3534.056	2013	2
2/19/2013	1	3498.162	2013	2
2/19/2013	2	3481.762	2013	2
2/19/2013	3	3447.362	2013	2
2/19/2013	4	3478.259	2013	2
2/19/2013	5	3706.856	2013	2
2/19/2013	6	4165.343	2013	2
2/19/2013	7	4510.559	2013	2
2/19/2013	8	4570.259	2013	2
2/19/2013	9	4615.859	2013	2
2/19/2013	10	4662.559	2013	2
2/19/2013	11	4592.554	2013	2
2/19/2013	12	4561.949	2013	2
2/19/2013	13	4518.36	2013	2

Day	Hr	Total	Year	Month
2/19/2013	14	4431.362	2013	2
2/19/2013	15	4322.462	2013	2
2/19/2013	16	4317.562	2013	2
2/19/2013	17	4383.551	2013	2
2/19/2013	18	4690.754	2013	2
2/19/2013	19	4859.16	2013	2
2/19/2013	20	4868.461	2013	2
2/19/2013	21	4801.861	2013	2
2/19/2013	22	4602.028	2013	2
2/19/2013	23	4389.345	2013	2
2/20/2013	0	4350.958	2013	2
2/20/2013	1	4314.46	2013	2
2/20/2013	2	4270.86	2013	2
2/20/2013	3	4327.783	2013	2
2/20/2013	4	4389.846	2013	2
2/20/2013	5	4592.755	2013	2
2/20/2013	6	5009.36	2013	2
2/20/2013	7	5261.959	2013	2
2/20/2013	8	5169.059	2013	2
2/20/2013	9	5056.444	2013	2
2/20/2013	10	4919.961	2013	2
2/20/2013	11	4780.761	2013	2
2/20/2013	12	4706.362	2013	2
2/20/2013	13	4631.062	2013	2
2/20/2013	14	4535.055	2013	2
2/20/2013	15	4504.153	2013	2
2/20/2013	16	4504.063	2013	2
2/20/2013	17	4610.162	2013	2
2/20/2013	18	4907.562	2013	2
2/20/2013	19	5003.961	2013	2
2/20/2013	20	5007.348	2013	2
2/20/2013	21	4840.457	2013	2
2/20/2013	22	4688.761	2013	2
2/20/2013	23	4521.161	2013	2
2/21/2013	0	4433.061	2013	2
2/21/2013	1	4361.751	2013	2
2/21/2013	2	4371.153	2013	2
2/21/2013	3	4372.86	2013	2
2/21/2013	4	4422.261	2013	2
2/21/2013	5	4727.061	2013	2
2/21/2013	6	5149.148	2013	2
2/21/2013	7	5406.755	2013	2
2/21/2013	8	5297.761	2013	2
2/21/2013	9	5138.361	2013	2
2/21/2013	10	4967.286	2013	2
2/21/2013	11	4768.851	2013	2
2/21/2013	12	4636.456	2013	2
2/21/2013	13	4572.563	2013	2
2/21/2013	14	4459.562	2013	2
2/21/2013	15	4434.762	2013	2
2/21/2013	16	4535.657	2013	2
2/21/2013	17	4625.55	2013	2
2/21/2013	18	4778.962	2013	2
2/21/2013	19	4886.862	2013	2
2/21/2013	20	4817.361	2013	2
2/21/2013	21	4692.758	2013	2
2/21/2013	22	4499.247	2013	2
2/21/2013	23	4277.961	2013	2
2/22/2013	0	4151.462	2013	2
2/22/2013	1	4028.361	2013	2
2/22/2013	2	3952.96	2013	2
2/22/2013	3	3884.248	2013	2
2/22/2013	4	3875.061	2013	2
2/22/2013	5	4026.562	2013	2

Day	Hr	Total	Year	Month
2/22/2013	6	4325.66	2013	2
2/22/2013	7	4562.562	2013	2
2/22/2013	8	4508.45	2013	2
2/22/2013	9	4470.456	2013	2
2/22/2013	10	4409.563	2013	2
2/22/2013	11	4283.304	2013	2
2/22/2013	12	4191.662	2013	2
2/22/2013	13	4103.662	2013	2
2/22/2013	14	4026.648	2013	2
2/22/2013	15	3890.461	2013	2
2/22/2013	16	3831.662	2013	2
2/22/2013	17	3809.662	2013	2
2/22/2013	18	3920.862	2013	2
2/22/2013	19	4001.261	2013	2
2/22/2013	20	3984.256	2013	2
2/22/2013	21	3981.751	2013	2
2/22/2013	22	3820.962	2013	2
2/22/2013	23	3656.761	2013	2
2/23/2013	0	3509.862	2013	2
2/23/2013	1	3437.862	2013	2
2/23/2013	2	3343.056	2013	2
2/23/2013	3	3335.449	2013	2
2/23/2013	4	3309.661	2013	2
2/23/2013	5	3369.361	2013	2
2/23/2013	6	3540.961	2013	2
2/23/2013	7	3788.261	2013	2
2/23/2013	8	3971.648	2013	2
2/23/2013	9	4014.657	2013	2
2/23/2013	10	3926.362	2013	2
2/23/2013	11	3881.662	2013	2
2/23/2013	12	3689.362	2013	2
2/23/2013	13	3574.463	2013	2
2/23/2013	14	3409.559	2013	2
2/23/2013	15	3359.352	2013	2
2/23/2013	16	3399.163	2013	2
2/23/2013	17	3452.263	2013	2
2/23/2013	18	3662.463	2013	2
2/23/2013	19	3893.262	2013	2
2/23/2013	20	3932.662	2013	2
2/23/2013	21	3865.352	2013	2
2/23/2013	22	3777.677	2013	2
2/23/2013	23	3660.162	2013	2
2/24/2013	0	3573.661	2013	2
2/24/2013	1	3512.462	2013	2
2/24/2013	2	3521.66	2013	2
2/24/2013	3	3549.348	2013	2
2/24/2013	4	3603.256	2013	2
2/24/2013	5	3700.36	2013	2
2/24/2013	6	3887.861	2013	2
2/24/2013	7	3986.96	2013	2
2/24/2013	8	4025.354	2013	2
2/24/2013	9	3995.052	2013	2
2/24/2013	10	3865.762	2013	2
2/24/2013	11	3622.862	2013	2
2/24/2013	12	3535.563	2013	2
2/24/2013	13	3496.064	2013	2
2/24/2013	14	3355.863	2013	2
2/24/2013	15	3324.548	2013	2
2/24/2013	16	3262.663	2013	2
2/24/2013	17	3343.763	2013	2
2/24/2013	18	3636.163	2013	2
2/24/2013	19	3884.463	2013	2
2/24/2013	20	3992.162	2013	2
2/24/2013	21	3874.758	2013	2

Day	Hr	Total	Year	Month
2/24/2013	22	3794.148	2013	2
2/24/2013	23	3714.361	2013	2
2/25/2013	0	3631.562	2013	2
2/25/2013	1	3665.762	2013	2
2/25/2013	2	3686.461	2013	2
2/25/2013	3	3735.259	2013	2
2/25/2013	4	3845.146	2013	2
2/25/2013	5	4131.961	2013	2
2/25/2013	6	4600.661	2013	2
2/25/2013	7	4852.761	2013	2
2/25/2013	8	4823.661	2013	2
2/25/2013	9	4719.855	2013	2
2/25/2013	10	4589.153	2013	2
2/25/2013	11	4414.762	2013	2
2/25/2013	12	4329.863	2013	2
2/25/2013	13	4152.264	2013	2
2/25/2013	14	4087.162	2013	2
2/25/2013	15	3977.464	2013	2
2/25/2013	16	3926.95	2013	2
2/25/2013	17	3960.861	2013	2
2/25/2013	18	4200.363	2013	2
2/25/2013	19	4429.563	2013	2
2/25/2013	20	4431.663	2013	2
2/25/2013	21	4282.263	2013	2
2/25/2013	22	4112.863	2013	2
2/25/2013	23	3858.046	2013	2
2/26/2013	0	3705.462	2013	2
2/26/2013	1	3614.363	2013	2
2/26/2013	2	3542.162	2013	2
2/26/2013	3	3489.364	2013	2
2/26/2013	4	3526.962	2013	2
2/26/2013	5	3679.956	2013	2
2/26/2013	6	4072.952	2013	2
2/26/2013	7	4322.663	2013	2
2/26/2013	8	4310.162	2013	2
2/26/2013	9	4303.963	2013	2
2/26/2013	10	4268.163	2013	2
2/26/2013	11	4237.363	2013	2
2/26/2013	12	4234.05	2013	2
2/26/2013	13	4250.157	2013	2
2/26/2013	14	4145.863	2013	2
2/26/2013	15	4057.463	2013	2
2/26/2013	16	4053.063	2013	2
2/26/2013	17	4117.763	2013	2
2/26/2013	18	4373.559	2013	2
2/26/2013	19	4368.051	2013	2
2/26/2013	20	4347.757	2013	2
2/26/2013	21	4210.063	2013	2
2/26/2013	22	4001.762	2013	2
2/26/2013	23	3779.962	2013	2
2/27/2013	0	3706.162	2013	2
2/27/2013	1	3612.354	2013	2
2/27/2013	2	3598.752	2013	2
2/27/2013	3	3555.862	2013	2
2/27/2013	4	3607.562	2013	2
2/27/2013	5	3828.462	2013	2
2/27/2013	6	4235.962	2013	2
2/27/2013	7	4528.955	2013	2
2/27/2013	8	4558.051	2013	2
2/27/2013	9	4618.862	2013	2
2/27/2013	10	4672.362	2013	2
2/27/2013	11	4583.962	2013	2
2/27/2013	12	4651.262	2013	2
2/27/2013	13	4630.454	2013	2

Day	Hr	Total	Year	Month
2/27/2013	14	4632.153	2013	2
2/27/2013	15	4581.562	2013	2
2/27/2013	16	4577.362	2013	2
2/27/2013	17	4588.363	2013	2
2/27/2013	18	4799.061	2013	2
2/27/2013	19	4872.351	2013	2
2/27/2013	20	4869.254	2013	2
2/27/2013	21	4706.861	2013	2
2/27/2013	22	4488.161	2013	2
2/27/2013	23	4237.861	2013	2
2/28/2013	0	4059.261	2013	2
2/28/2013	1	3998.745	2013	2
2/28/2013	2	3939.36	2013	2
2/28/2013	3	3970.76	2013	2
2/28/2013	4	4029.961	2013	2
2/28/2013	5	4194.261	2013	2
2/28/2013	6	4570.831	2013	2
2/28/2013	7	4843.15	2013	2
2/28/2013	8	4874.361	2013	2
2/28/2013	9	4911.961	2013	2
2/28/2013	10	4962.961	2013	2
2/28/2013	11	4945.16	2013	2
2/28/2013	12	4980.345	2013	2
2/28/2013	13	4969.66	2013	2
2/28/2013	14	4858.962	2013	2
2/28/2013	15	4811.561	2013	2
2/28/2013	16	4798.16	2013	2
2/28/2013	17	4841.353	2013	2
2/28/2013	18	4881.053	2013	2
2/28/2013	19	4907.96	2013	2
2/28/2013	20	4874.261	2013	2
2/28/2013	21	4723.161	2013	2
2/28/2013	22	4494.661	2013	2
2/28/2013	23	4253.845	2013	2
3/1/2013	0	4073.96	2013	3
3/1/2013	1	3888.661	2013	3
3/1/2013	2	3863.161	2013	3
3/1/2013	3	3925.061	2013	3
3/1/2013	4	3894.659	2013	3
3/1/2013	5	4050.447	2013	3
3/1/2013	6	4439.561	2013	3
3/1/2013	7	4670.391	2013	3
3/1/2013	8	4705.561	2013	3
3/1/2013	9	4733.661	2013	3
3/1/2013	10	4708.454	2013	3
3/1/2013	11	4658.554	2013	3
3/1/2013	12	4591.662	2013	3
3/1/2013	13	4541.562	2013	3
3/1/2013	14	4501.862	2013	3
3/1/2013	15	4431.362	2013	3
3/1/2013	16	4392.156	2013	3
3/1/2013	17	4501.651	2013	3
3/1/2013	18	4597.662	2013	3
3/1/2013	19	4650.161	2013	3
3/1/2013	20	4534.161	2013	3
3/1/2013	21	4501.062	2013	3
3/1/2013	22	4377.954	2013	3
3/1/2013	23	4220.052	2013	3
3/2/2013	0	4039.761	2013	3
3/2/2013	1	3980.362	2013	3
3/2/2013	2	3880.461	2013	3
3/2/2013	3	3852.762	2013	3
3/2/2013	4	3864.048	2013	3
3/2/2013	5	3927.157	2013	3

Day	Hr	Total	Year	Month
3/2/2013	6	4119.561	2013	3
3/2/2013	7	4223.562	2013	3
3/2/2013	8	4362.962	2013	3
3/2/2013	9	4463.155	2013	3
3/2/2013	10	4545.251	2013	3
3/2/2013	11	4539.761	2013	3
3/2/2013	12	4470.162	2013	3
3/2/2013	13	4487.263	2013	3
3/2/2013	14	4460.362	2013	3
3/2/2013	15	4438.648	2013	3
3/2/2013	16	4459.358	2013	3
3/2/2013	17	4477.262	2013	3
3/2/2013	18	4598.662	2013	3
3/2/2013	19	4689.561	2013	3
3/2/2013	20	4599.355	2013	3
3/2/2013	21	4470.75	2013	3
3/2/2013	22	4379.561	2013	3
3/2/2013	23	4174.861	2013	3
3/3/2013	0	4056.86	2013	3
3/3/2013	1	3974.161	2013	3
3/3/2013	2	3908.845	2013	3
3/3/2013	3	3879.66	2013	3
3/3/2013	4	3908.161	2013	3
3/3/2013	5	3997.861	2013	3
3/3/2013	6	4124.661	2013	3
3/3/2013	7	4182.45	2013	3
3/3/2013	8	4296.755	2013	3
3/3/2013	9	4329.262	2013	3
3/3/2013	10	4262.662	2013	3
3/3/2013	11	4195.062	2013	3
3/3/2013	12	4170.462	2013	3
3/3/2013	13	4078.348	2013	3
3/3/2013	14	4024.962	2013	3
3/3/2013	15	3922.963	2013	3
3/3/2013	16	3939.863	2013	3
3/3/2013	17	3922.563	2013	3
3/3/2013	18	4133.263	2013	3
3/3/2013	19	4436.849	2013	3
3/3/2013	20	4484.851	2013	3
3/3/2013	21	4415.655	2013	3
3/3/2013	22	4318.661	2013	3
3/3/2013	23	4182.461	2013	3
3/4/2013	0	4135.656	2013	3
3/4/2013	1	4116.546	2013	3
3/4/2013	2	4117.965	2013	3
3/4/2013	3	4215.266	2013	3
3/4/2013	4	4372.265	2013	3
3/4/2013	5	4625.562	2013	3
3/4/2013	6	5095.115	2013	3
3/4/2013	7	5252.266	2013	3
3/4/2013	8	5147.267	2013	3
3/4/2013	9	4924.668	2013	3
3/4/2013	10	4745.563	2013	3
3/4/2013	11	4537.257	2013	3
3/4/2013	12	4457.469	2013	3
3/4/2013	13	4391.168	2013	3
3/4/2013	14	4256.769	2013	3
3/4/2013	15	4243.969	2013	3
3/4/2013	16	4195.956	2013	3
3/4/2013	17	4227.965	2013	3
3/4/2013	18	4424.168	2013	3
3/4/2013	19	4537.269	2013	3
3/4/2013	20	4509.068	2013	3
3/4/2013	21	4323.068	2013	3

Day	Hr	Total	Year	Month
3/4/2013	22	4170.452	2013	3
3/4/2013	23	3881.368	2013	3
3/5/2013	0	3729.868	2013	3
3/5/2013	1	3682.169	2013	3
3/5/2013	2	3602.168	2013	3
3/5/2013	3	3576.666	2013	3
3/5/2013	4	3585.453	2013	3
3/5/2013	5	3741.869	2013	3
3/5/2013	6	4121.068	2013	3
3/5/2013	7	4400.868	2013	3
3/5/2013	8	4436.368	2013	3
3/5/2013	9	4397.362	2013	3
3/5/2013	10	4442.658	2013	3
3/5/2013	11	4405.069	2013	3
3/5/2013	12	4413.668	2013	3
3/5/2013	13	4421.069	2013	3
3/5/2013	14	4387.969	2013	3
3/5/2013	15	4357.164	2013	3
3/5/2013	16	4381.055	2013	3
3/5/2013	17	4499.668	2013	3
3/5/2013	18	4710.066	2013	3
3/5/2013	19	4817.266	2013	3
3/5/2013	20	4888.461	2013	3
3/5/2013	21	4817.453	2013	3
3/5/2013	22	4590.965	2013	3
3/5/2013	23	4487.466	2013	3
3/6/2013	0	4353.066	2013	3
3/6/2013	1	4286.356	2013	3
3/6/2013	2	4236.358	2013	3
3/6/2013	3	4217.967	2013	3
3/6/2013	4	4292.066	2013	3
3/6/2013	5	4456.067	2013	3
3/6/2013	6	4726.854	2013	3
3/6/2013	7	4962.464	2013	3
3/6/2013	8	5073.068	2013	3
3/6/2013	9	5138.567	2013	3
3/6/2013	10	5184.768	2013	3
3/6/2013	11	5137.452	2013	3
3/6/2013	12	5178.167	2013	3
3/6/2013	13	5128.968	2013	3
3/6/2013	14	5059.568	2013	3
3/6/2013	15	4998.768	2013	3
3/6/2013	16	4980.451	2013	3
3/6/2013	17	5006.268	2013	3
3/6/2013	18	5080.767	2013	3
3/6/2013	19	5132.276	2013	3
3/6/2013	20	5032.167	2013	3
3/6/2013	21	4860.851	2013	3
3/6/2013	22	4643.067	2013	3
3/6/2013	23	4414.367	2013	3
3/7/2013	0	4279.567	2013	3
3/7/2013	1	4166.365	2013	3
3/7/2013	2	4117.352	2013	3
3/7/2013	3	4052.467	2013	3
3/7/2013	4	4068.966	2013	3
3/7/2013	5	4310.168	2013	3
3/7/2013	6	4655.063	2013	3
3/7/2013	7	4881.553	2013	3
3/7/2013	8	4910.468	2013	3
3/7/2013	9	4902.667	2013	3
3/7/2013	10	4895.368	2013	3
3/7/2013	11	4804.763	2013	3
3/7/2013	12	4785.456	2013	3
3/7/2013	13	4719.368	2013	3

Day	Hr	Total	Year	Month
3/7/2013	14	4646.969	2013	3
3/7/2013	15	4607.468	2013	3
3/7/2013	16	4543.868	2013	3
3/7/2013	17	4636.152	2013	3
3/7/2013	18	4708.168	2013	3
3/7/2013	19	4863.967	2013	3
3/7/2013	20	4828.368	2013	3
3/7/2013	21	4698.868	2013	3
3/7/2013	22	4451.255	2013	3
3/7/2013	23	4242.264	2013	3
3/8/2013	0	4060.767	2013	3
3/8/2013	1	3969.968	2013	3
3/8/2013	2	3963.468	2013	3
3/8/2013	3	3960.257	2013	3
3/8/2013	4	4072.761	2013	3
3/8/2013	5	4343.067	2013	3
3/8/2013	6	4690.367	2013	3
3/8/2013	7	4887.568	2013	3
3/8/2013	8	4767.657	2013	3
3/8/2013	9	4590.863	2013	3
3/8/2013	10	4496.068	2013	3
3/8/2013	11	4324.369	2013	3
3/8/2013	12	4225.569	2013	3
3/8/2013	13	4121.469	2013	3
3/8/2013	14	3978.456	2013	3
3/8/2013	15	3821.568	2013	3
3/8/2013	16	3787.17	2013	3
3/8/2013	17	3778.169	2013	3
3/8/2013	18	3850.07	2013	3
3/8/2013	19	4118.368	2013	3
3/8/2013	20	4269.462	2013	3
3/8/2013	21	4215.458	2013	3
3/8/2013	22	4086.568	2013	3
3/8/2013	23	3974.068	2013	3
3/9/2013	0	3900.768	2013	3
3/9/2013	1	3810.368	2013	3
3/9/2013	2	3741.055	2013	3
3/9/2013	3	3757.663	2013	3
3/9/2013	4	3798.767	2013	3
3/9/2013	5	3882.968	2013	3
3/9/2013	6	3950.067	2013	3
3/9/2013	7	3973.163	2013	3
3/9/2013	8	4096.857	2013	3
3/9/2013	9	4016.368	2013	3
3/9/2013	10	3916.469	2013	3
3/9/2013	11	3775.87	2013	3
3/9/2013	12	3571.87	2013	3
3/9/2013	13	3422.47	2013	3
3/9/2013	14	3251.358	2013	3
3/9/2013	15	3243.366	2013	3
3/9/2013	16	3244.27	2013	3
3/9/2013	17	3340.07	2013	3
3/9/2013	18	3460.27	2013	3
3/9/2013	19	3596.769	2013	3
3/9/2013	20	3552.07	2013	3
3/9/2013	21	3415.169	2013	3
3/9/2013	22	3256.053	2013	3
3/9/2013	23	3129.868	2013	3
3/10/2013	0	2971.269	2013	3
3/10/2013	1	2941.269	2013	3
3/10/2013	2	2863.57	2013	3
3/10/2013	3	2809.969	2013	3
3/10/2013	4	2908.069	2013	3
3/10/2013	5	2968.76	2013	3

Day	Hr	Total	Year	Month
3/10/2013	6	3099.061	2013	3
3/10/2013	7	3189.47	2013	3
3/10/2013	8	3254.57	2013	3
3/10/2013	9	3272.269	2013	3
3/10/2013	10	3238.47	2013	3
3/10/2013	11	3200.27	2013	3
3/10/2013	12	3169.17	2013	3
3/10/2013	13	3091.659	2013	3
3/10/2013	14	2980.365	2013	3
3/10/2013	15	3019.57	2013	3
3/10/2013	16	3072.57	2013	3
3/10/2013	17	3099.371	2013	3
3/10/2013	18	3326.37	2013	3
3/10/2013	19	3489.97	2013	3
3/10/2013	20	3448.969	2013	3
3/10/2013	21	3257.57	2013	3
3/10/2013	22	3054.569	2013	3
3/10/2013	23	2910.053	2013	3
3/11/2013	0	2792.669	2013	3
3/11/2013	1	2735.569	2013	3
3/11/2013	2	2745.869	2013	3
3/11/2013	3	2873.07	2013	3
3/11/2013	4	3048.769	2013	3
3/11/2013	5	3450.269	2013	3
3/11/2013	6	3760.969	2013	3
3/11/2013	7	3840.253	2013	3
3/11/2013	8	3860.169	2013	3
3/11/2013	9	3957.369	2013	3
3/11/2013	10	3982.069	2013	3
3/11/2013	11	4019.369	2013	3
3/11/2013	12	3981.869	2013	3
3/11/2013	13	3974.369	2013	3
3/11/2013	14	3976.354	2013	3
3/11/2013	15	3957.067	2013	3
3/11/2013	16	4001.069	2013	3
3/11/2013	17	4040.668	2013	3
3/11/2013	18	4165.269	2013	3
3/11/2013	19	4249.168	2013	3
3/11/2013	20	4164.762	2013	3
3/11/2013	21	3953.356	2013	3
3/11/2013	22	3760.668	2013	3
3/11/2013	23	3598.467	2013	3
3/12/2013	0	3526.768	2013	3
3/12/2013	1	3468.867	2013	3
3/12/2013	2	3467.36	2013	3
3/12/2013	3	3501.558	2013	3
3/12/2013	4	3734.485	2013	3
3/12/2013	5	4192.167	2013	3
3/12/2013	6	4485.267	2013	3
3/12/2013	7	4537.568	2013	3
3/12/2013	8	4530.654	2013	3
3/12/2013	9	4501.065	2013	3
3/12/2013	10	4438.668	2013	3
3/12/2013	11	4321.069	2013	3
3/12/2013	12	4259.669	2013	3
3/12/2013	13	4115.069	2013	3
3/12/2013	14	3957.76	2013	3
3/12/2013	15	3889.862	2013	3
3/12/2013	16	3864.17	2013	3
3/12/2013	17	3880.67	2013	3
3/12/2013	18	4047.769	2013	3
3/12/2013	19	4314.468	2013	3
3/12/2013	20	4284.468	2013	3
3/12/2013	21	4087.152	2013	3

Day	Hr	Total	Year	Month
3/12/2013	22	3877.067	2013	3
3/12/2013	23	3712.268	2013	3
3/13/2013	0	3695.968	2013	3
3/13/2013	1	3683.269	2013	3
3/13/2013	2	3647.067	2013	3
3/13/2013	3	3738.851	2013	3
3/13/2013	4	3967.266	2013	3
3/13/2013	5	4400.967	2013	3
3/13/2013	6	4791.768	2013	3
3/13/2013	7	4777.11	2013	3
3/13/2013	8	4766.658	2013	3
3/13/2013	9	4805.035	2013	3
3/13/2013	10	4757.53	2013	3
3/13/2013	11	4776.128	2013	3
3/13/2013	12	4677.523	2013	3
3/13/2013	13	4667.926	2013	3
3/13/2013	14	4572.631	2013	3
3/13/2013	15	4577.239	2013	3
3/13/2013	16	4547.63	2013	3
3/13/2013	17	4597.729	2013	3
3/13/2013	18	4740.03	2013	3
3/13/2013	19	4930.68	2013	3
3/13/2013	20	4801.129	2013	3
3/13/2013	21	4647.429	2013	3
3/13/2013	22	4448.628	2013	3
3/13/2013	23	4339.629	2013	3
3/14/2013	0	4162.329	2013	3
3/14/2013	1	4190.828	2013	3
3/14/2013	2	4251.029	2013	3
3/14/2013	3	4280.529	2013	3
3/14/2013	4	4538.028	2013	3
3/14/2013	5	4951.729	2013	3
3/14/2013	6	5263.728	2013	3
3/14/2013	7	5210.229	2013	3
3/14/2013	8	5035.329	2013	3
3/14/2013	9	4847.53	2013	3
3/14/2013	10	4620.731	2013	3
3/14/2013	11	4496.136	2013	3
3/14/2013	12	4400.048	2013	3
3/14/2013	13	4182.44	2013	3
3/14/2013	14	4107.344	2013	3
3/14/2013	15	4010.949	2013	3
3/14/2013	16	4002.042	2013	3
3/14/2013	17	4078.932	2013	3
3/14/2013	18	4248.347	2013	3
3/14/2013	19	4457.548	2013	3
3/14/2013	20	4377.845	2013	3
3/14/2013	21	4203.732	2013	3
3/14/2013	22	4009.335	2013	3
3/14/2013	23	3896.848	2013	3
3/15/2013	0	3803.847	2013	3
3/15/2013	1	3746.943	2013	3
3/15/2013	2	3771.831	2013	3
3/15/2013	3	3818.23	2013	3
3/15/2013	4	4006.147	2013	3
3/15/2013	5	4410.741	2013	3
3/15/2013	6	4650.831	2013	3
3/15/2013	7	4612.33	2013	3
3/15/2013	8	4505.831	2013	3
3/15/2013	9	4353.961	2013	3
3/15/2013	10	4163.169	2013	3
3/15/2013	11	4034.669	2013	3
3/15/2013	12	3959.362	2013	3
3/15/2013	13	3826.853	2013	3

Day	Hr	Total	Year	Month
3/15/2013	14	3693.067	2013	3
3/15/2013	15	3609.667	2013	3
3/15/2013	16	3555.668	2013	3
3/15/2013	17	3513.568	2013	3
3/15/2013	18	3590.567	2013	3
3/15/2013	19	3723.267	2013	3
3/15/2013	20	3631.667	2013	3
3/15/2013	21	3507.667	2013	3
3/15/2013	22	3345.564	2013	3
3/15/2013	23	3162.451	2013	3
3/16/2013	0	3023.367	2013	3
3/16/2013	1	2934.392	2013	3
3/16/2013	2	2857.768	2013	3
3/16/2013	3	2821.467	2013	3
3/16/2013	4	2861.667	2013	3
3/16/2013	5	2971.367	2013	3
3/16/2013	6	3119.467	2013	3
3/16/2013	7	3189.061	2013	3
3/16/2013	8	3277.256	2013	3
3/16/2013	9	3301.667	2013	3
3/16/2013	10	3282.267	2013	3
3/16/2013	11	3216.068	2013	3
3/16/2013	12	3177.768	2013	3
3/16/2013	13	3109.568	2013	3
3/16/2013	14	3112.368	2013	3
3/16/2013	15	3119.168	2013	3
3/16/2013	16	3085.567	2013	3
3/16/2013	17	3099.068	2013	3
3/16/2013	18	3146.468	2013	3
3/16/2013	19	3343.153	2013	3
3/16/2013	20	3266.962	2013	3
3/16/2013	21	3121.667	2013	3
3/16/2013	22	2939.967	2013	3
3/16/2013	23	2842.167	2013	3
3/17/2013	0	2793.067	2013	3
3/17/2013	1	2769.067	2013	3
3/17/2013	2	2730.967	2013	3
3/17/2013	3	2780.854	2013	3
3/17/2013	4	2881.561	2013	3
3/17/2013	5	2980.467	2013	3
3/17/2013	6	3189.367	2013	3
3/17/2013	7	3405.566	2013	3
3/17/2013	8	3597.467	2013	3
3/17/2013	9	3756.964	2013	3
3/17/2013	10	3798.95	2013	3
3/17/2013	11	3880.066	2013	3
3/17/2013	12	3849.266	2013	3
3/17/2013	13	3892.867	2013	3
3/17/2013	14	3938.866	2013	3
3/17/2013	15	3917.363	2013	3
3/17/2013	16	3985.751	2013	3
3/17/2013	17	4001.666	2013	3
3/17/2013	18	4122.466	2013	3
3/17/2013	19	4240.166	2013	3
3/17/2013	20	4164.966	2013	3
3/17/2013	21	3963.256	2013	3
3/17/2013	22	3740.158	2013	3
3/17/2013	23	3597.066	2013	3
3/18/2013	0	3513.266	2013	3
3/18/2013	1	3482.366	2013	3
3/18/2013	2	3454.366	2013	3
3/18/2013	3	3556.15	2013	3
3/18/2013	4	3763.065	2013	3
3/18/2013	5	4176.966	2013	3

Day	Hr	Total	Year	Month
3/18/2013	6	4403.465	2013	3
3/18/2013	7	4471.166	2013	3
3/18/2013	8	4471.357	2013	3
3/18/2013	9	4471.457	2013	3
3/18/2013	10	4429.364	2013	3
3/18/2013	11	4424.21	2013	3
3/18/2013	12	4358.247	2013	3
3/18/2013	13	4318.647	2013	3
3/18/2013	14	4209.547	2013	3
3/18/2013	15	4170.648	2013	3
3/18/2013	16	4133.046	2013	3
3/18/2013	17	4116.847	2013	3
3/18/2013	18	4157.945	2013	3
3/18/2013	19	4254.245	2013	3
3/18/2013	20	4133.945	2013	3
3/18/2013	21	3937.934	2013	3
3/18/2013	22	3789.328	2013	3
3/18/2013	23	3625.341	2013	3
3/19/2013	0	3543.345	2013	3
3/19/2013	1	3542.73	2013	3
3/19/2013	2	3600.927	2013	3
3/19/2013	3	3606.527	2013	3
3/19/2013	4	3854.828	2013	3
3/19/2013	5	4337.529	2013	3
3/19/2013	6	4656.238	2013	3
3/19/2013	7	4637.843	2013	3
3/19/2013	8	4560.13	2013	3
3/19/2013	9	4484.23	2013	3
3/19/2013	10	4377.73	2013	3
3/19/2013	11	4308.331	2013	3
3/19/2013	12	4237.43	2013	3
3/19/2013	13	4177.734	2013	3
3/19/2013	14	4060.848	2013	3
3/19/2013	15	4002.448	2013	3
3/19/2013	16	3938.446	2013	3
3/19/2013	17	3901.832	2013	3
3/19/2013	18	4078.142	2013	3
3/19/2013	19	4367.747	2013	3
3/19/2013	20	4325.747	2013	3
3/19/2013	21	4222.647	2013	3
3/19/2013	22	3970.443	2013	3
3/19/2013	23	3836.33	2013	3
3/20/2013	0	3765.541	2013	3
3/20/2013	1	3755.646	2013	3
3/20/2013	2	3765.843	2013	3
3/20/2013	3	3841.83	2013	3
3/20/2013	4	4144.835	2013	3
3/20/2013	5	4663.246	2013	3
3/20/2013	6	4917.44	2013	3
3/20/2013	7	4843.523	2013	3
3/20/2013	8	4653.33	2013	3
3/20/2013	9	4532.542	2013	3
3/20/2013	10	4398.05	2013	3
3/20/2013	11	4340.157	2013	3
3/20/2013	12	4321.052	2013	3
3/20/2013	13	4266.266	2013	3
3/20/2013	14	4200.667	2013	3
3/20/2013	15	4146.767	2013	3
3/20/2013	16	4185.767	2013	3
3/20/2013	17	4286.766	2013	3
3/20/2013	18	4463.166	2013	3
3/20/2013	19	4800.56	2013	3
3/20/2013	20	4757.947	2013	3
3/20/2013	21	4609.564	2013	3

Day	Hr	Total	Year	Month
3/20/2013	22	4458.463	2013	3
3/20/2013	23	4328.164	2013	3
3/21/2013	0	4243.563	2013	3
3/21/2013	1	4214.751	2013	3
3/21/2013	2	4247.758	2013	3
3/21/2013	3	4360.363	2013	3
3/21/2013	4	4573.163	2013	3
3/21/2013	5	5030.964	2013	3
3/21/2013	6	5281.05	2013	3
3/21/2013	7	5283.66	2013	3
3/21/2013	8	5171.765	2013	3
3/21/2013	9	5170.866	2013	3
3/21/2013	10	5009.565	2013	3
3/21/2013	11	4963.953	2013	3
3/21/2013	12	4864.561	2013	3
3/21/2013	13	4732.865	2013	3
3/21/2013	14	4574.266	2013	3
3/21/2013	15	4426.666	2013	3
3/21/2013	16	4324.164	2013	3
3/21/2013	17	4339.15	2013	3
3/21/2013	18	4436.566	2013	3
3/21/2013	19	4800.464	2013	3
3/21/2013	20	4817.863	2013	3
3/21/2013	21	4656.963	2013	3
3/21/2013	22	4481.652	2013	3
3/21/2013	23	4385.157	2013	3
3/22/2013	0	4331.862	2013	3
3/22/2013	1	4279.362	2013	3
3/22/2013	2	4309.162	2013	3
3/22/2013	3	4435.15	2013	3
3/22/2013	4	4649.944	2013	3
3/22/2013	5	5080.162	2013	3
3/22/2013	6	5345.563	2013	3
3/22/2013	7	5205.963	2013	3
3/22/2013	8	5007.648	2013	3
3/22/2013	9	4847.163	2013	3
3/22/2013	10	4650.166	2013	3
3/22/2013	11	4494.466	2013	3
3/22/2013	12	4391.666	2013	3
3/22/2013	13	4227.663	2013	3
3/22/2013	14	4079.053	2013	3
3/22/2013	15	4001.9	2013	3
3/22/2013	16	4020.832	2013	3
3/22/2013	17	4042.566	2013	3
3/22/2013	18	4117.266	2013	3
3/22/2013	19	4274.264	2013	3
3/22/2013	20	4197.449	2013	3
3/22/2013	21	4067.763	2013	3
3/22/2013	22	3859.664	2013	3
3/22/2013	23	3721.665	2013	3
3/23/2013	0	3616.864	2013	3
3/23/2013	1	3533.464	2013	3
3/23/2013	2	3469.348	2013	3
3/23/2013	3	3494.165	2013	3
3/23/2013	4	3515.765	2013	3
3/23/2013	5	3631.964	2013	3
3/23/2013	6	3823.766	2013	3
3/23/2013	7	3964.061	2013	3
3/23/2013	8	4069.453	2013	3
3/23/2013	9	4105.766	2013	3
3/23/2013	10	3937.066	2013	3
3/23/2013	11	3774.666	2013	3
3/23/2013	12	3595.067	2013	3
3/23/2013	13	3517.767	2013	3

Day	Hr	Total	Year	Month
3/23/2013	14	3389.957	2013	3
3/23/2013	15	3363.46	2013	3
3/23/2013	16	3295.867	2013	3
3/23/2013	17	3344.967	2013	3
3/23/2013	18	3413.067	2013	3
3/23/2013	19	3668.366	2013	3
3/23/2013	20	3609.165	2013	3
3/23/2013	21	3548.06	2013	3
3/23/2013	22	3397.554	2013	3
3/23/2013	23	3269.466	2013	3
3/24/2013	0	3138.165	2013	3
3/24/2013	1	3049.465	2013	3
3/24/2013	2	3075.266	2013	3
3/24/2013	3	3122.465	2013	3
3/24/2013	4	3189.857	2013	3
3/24/2013	5	3326.555	2013	3
3/24/2013	6	3448.466	2013	3
3/24/2013	7	3657.365	2013	3
3/24/2013	8	3868.766	2013	3
3/24/2013	9	3909.866	2013	3
3/24/2013	10	3936.158	2013	3
3/24/2013	11	3962.855	2013	3
3/24/2013	12	3986.766	2013	3
3/24/2013	13	3916.865	2013	3
3/24/2013	14	3897.666	2013	3
3/24/2013	15	3923.266	2013	3
3/24/2013	16	3980.357	2013	3
3/24/2013	17	3973.356	2013	3
3/24/2013	18	4041.266	2013	3
3/24/2013	19	4126.364	2013	3
3/24/2013	20	4085.564	2013	3
3/24/2013	21	3923.264	2013	3
3/24/2013	22	3773.053	2013	3
3/24/2013	23	3706.758	2013	3
3/25/2013	0	3702.763	2013	3
3/25/2013	1	3735.564	2013	3
3/25/2013	2	3766.662	2013	3
3/25/2013	3	3948.355	2013	3
3/25/2013	4	4204.454	2013	3
3/25/2013	5	4623.862	2013	3
3/25/2013	6	4909.864	2013	3
3/25/2013	7	4984.364	2013	3
3/25/2013	8	5011.56	2013	3
3/25/2013	9	5053.198	2013	3
3/25/2013	10	4972.365	2013	3
3/25/2013	11	4971.962	2013	3
3/25/2013	12	4972.565	2013	3
3/25/2013	13	4949.064	2013	3
3/25/2013	14	4855.248	2013	3
3/25/2013	15	4849.865	2013	3
3/25/2013	16	4829.664	2013	3
3/25/2013	17	4865.564	2013	3
3/25/2013	18	4964.663	2013	3
3/25/2013	19	5039.447	2013	3
3/25/2013	20	4917.561	2013	3
3/25/2013	21	4690.063	2013	3
3/25/2013	22	4449.363	2013	3
3/25/2013	23	4270.664	2013	3
3/26/2013	0	4127.447	2013	3
3/26/2013	1	4081.362	2013	3
3/26/2013	2	4038.864	2013	3
3/26/2013	3	4110.363	2013	3
3/26/2013	4	4279.765	2013	3
3/26/2013	5	4672.35	2013	3

Day	Hr	Total	Year	Month
3/26/2013	6	4923.261	2013	3
3/26/2013	7	4912.664	2013	3
3/26/2013	8	4969.765	2013	3
3/26/2013	9	4967.966	2013	3
3/26/2013	10	4904.856	2013	3
3/26/2013	11	4826.558	2013	3
3/26/2013	12	4795.266	2013	3
3/26/2013	13	4716.366	2013	3
3/26/2013	14	4611.866	2013	3
3/26/2013	15	4529.965	2013	3
3/26/2013	16	4521.135	2013	3
3/26/2013	17	4529.561	2013	3
3/26/2013	18	4638.765	2013	3
3/26/2013	19	4752.665	2013	3
3/26/2013	20	4694.964	2013	3
3/26/2013	21	4466.062	2013	3
3/26/2013	22	4202.648	2013	3
3/26/2013	23	4042.863	2013	3
3/27/2013	0	3925.364	2013	3
3/27/2013	1	3948.563	2013	3
3/27/2013	2	3934.563	2013	3
3/27/2013	3	3977.453	2013	3
3/27/2013	4	4188.956	2013	3
3/27/2013	5	4675.063	2013	3
3/27/2013	6	4925.664	2013	3
3/27/2013	7	4863.465	2013	3
3/27/2013	8	4703.958	2013	3
3/27/2013	9	4611.054	2013	3
3/27/2013	10	4448.566	2013	3
3/27/2013	11	4383.149	2013	3
3/27/2013	12	4340.966	2013	3
3/27/2013	13	4262.319	2013	3
3/27/2013	14	4227.463	2013	3
3/27/2013	15	4176.753	2013	3
3/27/2013	16	4119.066	2013	3
3/27/2013	17	4089.366	2013	3
3/27/2013	18	4150.066	2013	3
3/27/2013	19	4441.864	2013	3
3/27/2013	20	4433.264	2013	3
3/27/2013	21	4268.552	2013	3
3/27/2013	22	4057.059	2013	3
3/27/2013	23	3954.364	2013	3
3/28/2013	0	3884.463	2013	3
3/28/2013	1	3900.863	2013	3
3/28/2013	2	3924.66	2013	3
3/28/2013	3	3972.048	2013	3
3/28/2013	4	4237.178	2013	3
3/28/2013	5	4737.663	2013	3
3/28/2013	6	4982.064	2013	3
3/28/2013	7	4914.364	2013	3
3/28/2013	8	4701.948	2013	3
3/28/2013	9	4507.865	2013	3
3/28/2013	10	4311.666	2013	3
3/28/2013	11	4192.866	2013	3
3/28/2013	12	4115.667	2013	3
3/28/2013	13	4017.167	2013	3
3/28/2013	14	3910.961	2013	3
3/28/2013	15	3722.556	2013	3
3/28/2013	16	3645.567	2013	3
3/28/2013	17	3646.966	2013	3
3/28/2013	18	3706.267	2013	3
3/28/2013	19	4011.465	2013	3
3/28/2013	20	4093.065	2013	3
3/28/2013	21	3920.459	2013	3

Day	Hr	Total	Year	Month
3/28/2013	22	3746.053	2013	3
3/28/2013	23	3631.964	2013	3
3/29/2013	0	3540.064	2013	3
3/29/2013	1	3565.264	2013	3
3/29/2013	2	3566.964	2013	3
3/29/2013	3	3632.758	2013	3
3/29/2013	4	3781.953	2013	3
3/29/2013	5	4197.763	2013	3
3/29/2013	6	4417.765	2013	3
3/29/2013	7	4359.664	2013	3
3/29/2013	8	4261.366	2013	3
3/29/2013	9	4119.255	2013	3
3/29/2013	10	3969.36	2013	3
3/29/2013	11	3829.367	2013	3
3/29/2013	12	3720.166	2013	3
3/29/2013	13	3619.967	2013	3
3/29/2013	14	3552.467	2013	3
3/29/2013	15	3449.466	2013	3
3/29/2013	16	3445.467	2013	3
3/29/2013	17	3424.351	2013	3
3/29/2013	18	3474.666	2013	3
3/29/2013	19	3658.666	2013	3
3/29/2013	20	3607.764	2013	3
3/29/2013	21	3538.366	2013	3
3/29/2013	22	3407.464	2013	3
3/29/2013	23	3259.166	2013	3
3/30/2013	0	3234.251	2013	3
3/30/2013	1	3178.961	2013	3
3/30/2013	2	3179.465	2013	3
3/30/2013	3	3225.464	2013	3
3/30/2013	4	3358.665	2013	3
3/30/2013	5	3492.064	2013	3
3/30/2013	6	3670.254	2013	3
3/30/2013	7	3762.46	2013	3
3/30/2013	8	3788.765	2013	3
3/30/2013	9	3700.866	2013	3
3/30/2013	10	3532.466	2013	3
3/30/2013	11	3400.067	2013	3
3/30/2013	12	3211.36	2013	3
3/30/2013	13	3143.157	2013	3
3/30/2013	14	3069.067	2013	3
3/30/2013	15	3064.367	2013	3
3/30/2013	16	3034.867	2013	3
3/30/2013	17	3055.567	2013	3
3/30/2013	18	3155.967	2013	3
3/30/2013	19	3346.366	2013	3
3/30/2013	20	3303.465	2013	3
3/30/2013	21	3166.451	2013	3
3/30/2013	22	3036.364	2013	3
3/30/2013	23	2908.765	2013	3
3/31/2013	0	2765.666	2013	3
3/31/2013	1	2717.665	2013	3
3/31/2013	2	2720.976	2013	3
3/31/2013	3	2669.366	2013	3
3/31/2013	4	2729.036	2013	3
3/31/2013	5	2858.354	2013	3
3/31/2013	6	2988.566	2013	3
3/31/2013	7	3119.966	2013	3
3/31/2013	8	3218.366	2013	3
3/31/2013	9	3245.167	2013	3
3/31/2013	10	3217.466	2013	3
3/31/2013	11	3204.467	2013	3
3/31/2013	12	3166.652	2013	3
3/31/2013	13	3008.363	2013	3

Day	Hr	Total	Year	Month
3/31/2013	14	2948.667	2013	3
3/31/2013	15	2864.268	2013	3
3/31/2013	16	2827.567	2013	3
3/31/2013	17	2833.167	2013	3
3/31/2013	18	2893.267	2013	3
3/31/2013	19	3187.766	2013	3
3/31/2013	20	3227.166	2013	3
3/31/2013	21	3138.051	2013	3
3/31/2013	22	3043.462	2013	3
3/31/2013	23	2878.365	2013	3
4/1/2013	0	2898.365	2013	4
4/1/2013	1	2857.665	2013	4
4/1/2013	2	2901.866	2013	4
4/1/2013	3	2958.965	2013	4
4/1/2013	4	3219.563	2013	4
4/1/2013	5	3531.95	2013	4
4/1/2013	6	3781.166	2013	4
4/1/2013	7	3894.865	2013	4
4/1/2013	8	3983.267	2013	4
4/1/2013	9	4045.165	2013	4
4/1/2013	10	3996.266	2013	4
4/1/2013	11	3968.966	2013	4
4/1/2013	12	3926.357	2013	4
4/1/2013	13	3821.959	2013	4
4/1/2013	14	3772.667	2013	4
4/1/2013	15	3623.366	2013	4
4/1/2013	16	3615.167	2013	4
4/1/2013	17	3608.566	2013	4
4/1/2013	18	3719.466	2013	4
4/1/2013	19	3937.366	2013	4
4/1/2013	20	3940.253	2013	4
4/1/2013	21	3810.958	2013	4
4/1/2013	22	3620.165	2013	4
4/1/2013	23	3523.565	2013	4
4/2/2013	0	3474.264	2013	4
4/2/2013	1	3471.164	2013	4
4/2/2013	2	3494.264	2013	4
4/2/2013	3	3601.648	2013	4
4/2/2013	4	3808.861	2013	4
4/2/2013	5	4216.264	2013	4
4/2/2013	6	4449.363	2013	4
4/2/2013	7	4424.565	2013	4
4/2/2013	8	4355.865	2013	4
4/2/2013	9	4242.851	2013	4
4/2/2013	10	4143.063	2013	4
4/2/2013	11	4055.866	2013	4
4/2/2013	12	4018.266	2013	4
4/2/2013	13	3924.767	2013	4
4/2/2013	14	3852.566	2013	4
4/2/2013	15	3692.366	2013	4
4/2/2013	16	3722.565	2013	4
4/2/2013	17	3666.952	2013	4
4/2/2013	18	3774.566	2013	4
4/2/2013	19	4007.665	2013	4
4/2/2013	20	4026.565	2013	4
4/2/2013	21	3953.864	2013	4
4/2/2013	22	3765.365	2013	4
4/2/2013	23	3722.064	2013	4
4/3/2013	0	3627.748	2013	4
4/3/2013	1	3585.362	2013	4
4/3/2013	2	3577.364	2013	4
4/3/2013	3	3758.863	2013	4
4/3/2013	4	3955.463	2013	4
4/3/2013	5	4345.262	2013	4

Day	Hr	Total	Year	Month
4/3/2013	6	4540.348	2013	4
4/3/2013	7	4501.564	2013	4
4/3/2013	8	4381.865	2013	4
4/3/2013	9	4248.2	2013	4
4/3/2013	10	4142.065	2013	4
4/3/2013	11	4059.766	2013	4
4/3/2013	12	4050.961	2013	4
4/3/2013	13	3959.655	2013	4
4/3/2013	14	3790.366	2013	4
4/3/2013	15	3690.967	2013	4
4/3/2013	16	3660.066	2013	4
4/3/2013	17	3683.767	2013	4
4/3/2013	18	3764.766	2013	4
4/3/2013	19	4066.265	2013	4
4/3/2013	20	4008.153	2013	4
4/3/2013	21	3887.46	2013	4
4/3/2013	22	3726.765	2013	4
4/3/2013	23	3623.503	2013	4
4/4/2013	0	3466.665	2013	4
4/4/2013	1	3476.665	2013	4
4/4/2013	2	3483.765	2013	4
4/4/2013	3	3459.252	2013	4
4/4/2013	4	3671.159	2013	4
4/4/2013	5	3986.665	2013	4
4/4/2013	6	4188.665	2013	4
4/4/2013	7	4292.866	2013	4
4/4/2013	8	4305.766	2013	4
4/4/2013	9	4246.264	2013	4
4/4/2013	10	4174.05	2013	4
4/4/2013	11	4151.466	2013	4
4/4/2013	12	4113.567	2013	4
4/4/2013	13	4027.966	2013	4
4/4/2013	14	4004.766	2013	4
4/4/2013	15	3850.567	2013	4
4/4/2013	16	3847.166	2013	4
4/4/2013	17	3850.766	2013	4
4/4/2013	18	3824.35	2013	4
4/4/2013	19	3999.865	2013	4
4/4/2013	20	3987.865	2013	4
4/4/2013	21	3790.565	2013	4
4/4/2013	22	3626.664	2013	4
4/4/2013	23	3478.865	2013	4
4/5/2013	0	3438.764	2013	4
4/5/2013	1	3366.949	2013	4
4/5/2013	2	3407.861	2013	4
4/5/2013	3	3421.564	2013	4
4/5/2013	4	3635.064	2013	4
4/5/2013	5	3998.764	2013	4
4/5/2013	6	4149.165	2013	4
4/5/2013	7	4177.054	2013	4
4/5/2013	8	4103.459	2013	4
4/5/2013	9	4006.466	2013	4
4/5/2013	10	3876.567	2013	4
4/5/2013	11	3774.466	2013	4
4/5/2013	12	3753.767	2013	4
4/5/2013	13	3680.466	2013	4
4/5/2013	14	3567.267	2013	4
4/5/2013	15	3451.867	2013	4
4/5/2013	16	3361.215	2013	4
4/5/2013	17	3361.252	2013	4
4/5/2013	18	3354.565	2013	4
4/5/2013	19	3571.866	2013	4
4/5/2013	20	3602.466	2013	4
4/5/2013	21	3444.665	2013	4

Day	Hr	Total	Year	Month
4/5/2013	22	3306.866	2013	4
4/5/2013	23	3145.165	2013	4
4/6/2013	0	3079.166	2013	4
4/6/2013	1	3000.163	2013	4
4/6/2013	2	3020.75	2013	4
4/6/2013	3	3030.664	2013	4
4/6/2013	4	3119.265	2013	4
4/6/2013	5	3257.866	2013	4
4/6/2013	6	3412.465	2013	4
4/6/2013	7	3449.766	2013	4
4/6/2013	8	3421.566	2013	4
4/6/2013	9	3369.362	2013	4
4/6/2013	10	3277.055	2013	4
4/6/2013	11	3173.466	2013	4
4/6/2013	12	3167.568	2013	4
4/6/2013	13	3145.667	2013	4
4/6/2013	14	3109.767	2013	4
4/6/2013	15	3093.466	2013	4
4/6/2013	16	3074.668	2013	4
4/6/2013	17	3039.467	2013	4
4/6/2013	18	3033.867	2013	4
4/6/2013	19	3134.466	2013	4
4/6/2013	20	3229.566	2013	4
4/6/2013	21	3108.866	2013	4
4/6/2013	22	2924.766	2013	4
4/6/2013	23	2657.355	2013	4
4/7/2013	0	2562.458	2013	4
4/7/2013	1	2603.366	2013	4
4/7/2013	2	2542.967	2013	4
4/7/2013	3	2541.465	2013	4
4/7/2013	4	2575.266	2013	4
4/7/2013	5	2672.767	2013	4
4/7/2013	6	2787.066	2013	4
4/7/2013	7	2898.893	2013	4
4/7/2013	8	2987.567	2013	4
4/7/2013	9	3051.767	2013	4
4/7/2013	10	3014.864	2013	4
4/7/2013	11	2985.951	2013	4
4/7/2013	12	3042.968	2013	4
4/7/2013	13	2972.567	2013	4
4/7/2013	14	2940.266	2013	4
4/7/2013	15	2963.368	2013	4
4/7/2013	16	3021.067	2013	4
4/7/2013	17	3101.467	2013	4
4/7/2013	18	3157.767	2013	4
4/7/2013	19	3326.566	2013	4
4/7/2013	20	3296.766	2013	4
4/7/2013	21	3117.266	2013	4
4/7/2013	22	2926.766	2013	4
4/7/2013	23	2761.466	2013	4
4/8/2013	0	2660.666	2013	4
4/8/2013	1	2695.466	2013	4
4/8/2013	2	2645.956	2013	4
4/8/2013	3	2748.356	2013	4
4/8/2013	4	2938.466	2013	4
4/8/2013	5	3329.567	2013	4
4/8/2013	6	3563.866	2013	4
4/8/2013	7	3602.567	2013	4
4/8/2013	8	3683.568	2013	4
4/8/2013	9	3666.866	2013	4
4/8/2013	10	3695.068	2013	4
4/8/2013	11	3772.067	2013	4
4/8/2013	12	3767.067	2013	4
4/8/2013	13	3769.767	2013	4

Day	Hr	Total	Year	Month
4/8/2013	14	3706.167	2013	4
4/8/2013	15	3696.366	2013	4
4/8/2013	16	3611.867	2013	4
4/8/2013	17	3620.467	2013	4
4/8/2013	18	3648.967	2013	4
4/8/2013	19	3862.361	2013	4
4/8/2013	20	3743.551	2013	4
4/8/2013	21	3520.867	2013	4
4/8/2013	22	3294.465	2013	4
4/8/2013	23	3112.766	2013	4
4/9/2013	0	2967.566	2013	4
4/9/2013	1	2860.866	2013	4
4/9/2013	2	2793.966	2013	4
4/9/2013	3	2793.066	2013	4
4/9/2013	4	2956.866	2013	4
4/9/2013	5	3309.866	2013	4
4/9/2013	6	3547.267	2013	4
4/9/2013	7	3593.767	2013	4
4/9/2013	8	3673.28	2013	4
4/9/2013	9	3750.767	2013	4
4/9/2013	10	3780.067	2013	4
4/9/2013	11	3865.067	2013	4
4/9/2013	12	3939.567	2013	4
4/9/2013	13	3976.967	2013	4
4/9/2013	14	4008.273	2013	4
4/9/2013	15	3972.458	2013	4
4/9/2013	16	4006.372	2013	4
4/9/2013	17	3955.674	2013	4
4/9/2013	18	3910.272	2013	4
4/9/2013	19	4074.067	2013	4
4/9/2013	20	4096.667	2013	4
4/9/2013	21	3796.971	2013	4
4/9/2013	22	3531.271	2013	4
4/9/2013	23	3232.67	2013	4
4/10/2013	0	3095.968	2013	4
4/10/2013	1	2964.766	2013	4
4/10/2013	2	2904.267	2013	4
4/10/2013	3	2874.67	2013	4
4/10/2013	4	2996.666	2013	4
4/10/2013	5	3399.366	2013	4
4/10/2013	6	3582.567	2013	4
4/10/2013	7	3665.668	2013	4
4/10/2013	8	3792.067	2013	4
4/10/2013	9	3922.467	2013	4
4/10/2013	10	4009.37	2013	4
4/10/2013	11	4108.972	2013	4
4/10/2013	12	4252.574	2013	4
4/10/2013	13	4347.575	2013	4
4/10/2013	14	4366.955	2013	4
4/10/2013	15	4417.778	2013	4
4/10/2013	16	4497.178	2013	4
4/10/2013	17	4426.575	2013	4
4/10/2013	18	4343.974	2013	4
4/10/2013	19	4421.774	2013	4
4/10/2013	20	4301.273	2013	4
4/10/2013	21	4031.471	2013	4
4/10/2013	22	3666.759	2013	4
4/10/2013	23	3448.564	2013	4
4/11/2013	0	3249.068	2013	4
4/11/2013	1	3133.867	2013	4
4/11/2013	2	3047.667	2013	4
4/11/2013	3	3060.726	2013	4
4/11/2013	4	3182.871	2013	4
4/11/2013	5	3542.566	2013	4

Day	Hr	Total	Year	Month
4/11/2013	6	3747.967	2013	4
4/11/2013	7	3776.567	2013	4
4/11/2013	8	3845.667	2013	4
4/11/2013	9	3909.967	2013	4
4/11/2013	10	3940.967	2013	4
4/11/2013	11	3975.367	2013	4
4/11/2013	12	4019.871	2013	4
4/11/2013	13	4080.667	2013	4
4/11/2013	14	3944.868	2013	4
4/11/2013	15	3977.067	2013	4
4/11/2013	16	3920.567	2013	4
4/11/2013	17	3873.567	2013	4
4/11/2013	18	3832.066	2013	4
4/11/2013	19	3912.353	2013	4
4/11/2013	20	3763.058	2013	4
4/11/2013	21	3579.666	2013	4
4/11/2013	22	3296.266	2013	4
4/11/2013	23	3130.766	2013	4
4/12/2013	0	2989.666	2013	4
4/12/2013	1	2917.266	2013	4
4/12/2013	2	2818.665	2013	4
4/12/2013	3	2841.866	2013	4
4/12/2013	4	3001.565	2013	4
4/12/2013	5	3356.257	2013	4
4/12/2013	6	3585.255	2013	4
4/12/2013	7	3656.766	2013	4
4/12/2013	8	3725.166	2013	4
4/12/2013	9	3729.667	2013	4
4/12/2013	10	3713.166	2013	4
4/12/2013	11	3714.167	2013	4
4/12/2013	12	3756.866	2013	4
4/12/2013	13	3739.567	2013	4
4/12/2013	14	3679.659	2013	4
4/12/2013	15	3663.556	2013	4
4/12/2013	16	3639.367	2013	4
4/12/2013	17	3640.566	2013	4
4/12/2013	18	3574.767	2013	4
4/12/2013	19	3709.765	2013	4
4/12/2013	20	3673.366	2013	4
4/12/2013	21	3528.565	2013	4
4/12/2013	22	3382.564	2013	4
4/12/2013	23	3199.949	2013	4
4/13/2013	0	3087.164	2013	4
4/13/2013	1	2981.664	2013	4
4/13/2013	2	2937.065	2013	4
4/13/2013	3	3003.165	2013	4
4/13/2013	4	3138.565	2013	4
4/13/2013	5	3339.965	2013	4
4/13/2013	6	3444.757	2013	4
4/13/2013	7	3548.856	2013	4
4/13/2013	8	3566.767	2013	4
4/13/2013	9	3552.066	2013	4
4/13/2013	10	3468.267	2013	4
4/13/2013	11	3367.367	2013	4
4/13/2013	12	3304.866	2013	4
4/13/2013	13	3153.967	2013	4
4/13/2013	14	3095.067	2013	4
4/13/2013	15	3081.067	2013	4
4/13/2013	16	3122.05	2013	4
4/13/2013	17	3092.867	2013	4
4/13/2013	18	3051.967	2013	4
4/13/2013	19	3240.467	2013	4
4/13/2013	20	3299.866	2013	4
4/13/2013	21	3195.065	2013	4

Day	Hr	Total	Year	Month
4/13/2013	22	3033.066	2013	4
4/13/2013	23	2872.265	2013	4
4/14/2013	0	2777.866	2013	4
4/14/2013	1	2709.855	2013	4
4/14/2013	2	2700.856	2013	4
4/14/2013	3	2743.265	2013	4
4/14/2013	4	2839.865	2013	4
4/14/2013	5	2982.765	2013	4
4/14/2013	6	3007.867	2013	4
4/14/2013	7	3138.766	2013	4
4/14/2013	8	3193.566	2013	4
4/14/2013	9	3137.463	2013	4
4/14/2013	10	3039.154	2013	4
4/14/2013	11	3083.467	2013	4
4/14/2013	12	3020.367	2013	4
4/14/2013	13	2992.267	2013	4
4/14/2013	14	3000.569	2013	4
4/14/2013	15	3115.371	2013	4
4/14/2013	16	3092.568	2013	4
4/14/2013	17	3134.367	2013	4
4/14/2013	18	3172.067	2013	4
4/14/2013	19	3378.967	2013	4
4/14/2013	20	3354.266	2013	4
4/14/2013	21	3095.766	2013	4
4/14/2013	22	2911.566	2013	4
4/14/2013	23	2750.766	2013	4
4/15/2013	0	2665.158	2013	4
4/15/2013	1	2631.055	2013	4
4/15/2013	2	2648.366	2013	4
4/15/2013	3	2729.466	2013	4
4/15/2013	4	2922.866	2013	4
4/15/2013	5	3322.666	2013	4
4/15/2013	6	3506.067	2013	4
4/15/2013	7	3598.567	2013	4
4/15/2013	8	3687.467	2013	4
4/15/2013	9	3750.666	2013	4
4/15/2013	10	3759.567	2013	4
4/15/2013	11	3788.667	2013	4
4/15/2013	12	3865.766	2013	4
4/15/2013	13	3872.871	2013	4
4/15/2013	14	3828.67	2013	4
4/15/2013	15	3850.57	2013	4
4/15/2013	16	3804.859	2013	4
4/15/2013	17	3843.855	2013	4
4/15/2013	18	3777.867	2013	4
4/15/2013	19	3877.567	2013	4
4/15/2013	20	3913.966	2013	4
4/15/2013	21	3666.866	2013	4
4/15/2013	22	3336.767	2013	4
4/15/2013	23	3124.265	2013	4
4/16/2013	0	2945.667	2013	4
4/16/2013	1	2870.566	2013	4
4/16/2013	2	2790.966	2013	4
4/16/2013	3	2815.666	2013	4
4/16/2013	4	2968.666	2013	4
4/16/2013	5	3398.067	2013	4
4/16/2013	6	3569.067	2013	4
4/16/2013	7	3675.467	2013	4
4/16/2013	8	3758.367	2013	4
4/16/2013	9	3865.167	2013	4
4/16/2013	10	3928.558	2013	4
4/16/2013	11	4041.857	2013	4
4/16/2013	12	4181.971	2013	4
4/16/2013	13	4227.67	2013	4

Day	Hr	Total	Year	Month
4/16/2013	14	4223.674	2013	4
4/16/2013	15	4280.274	2013	4
4/16/2013	16	4330.175	2013	4
4/16/2013	17	4284.525	2013	4
4/16/2013	18	4241.674	2013	4
4/16/2013	19	4303.768	2013	4
4/16/2013	20	4142.965	2013	4
4/16/2013	21	3796.666	2013	4
4/16/2013	22	3481.466	2013	4
4/16/2013	23	3266.266	2013	4
4/17/2013	0	3106.167	2013	4
4/17/2013	1	2960.173	2013	4
4/17/2013	2	2865.075	2013	4
4/17/2013	3	2844.366	2013	4
4/17/2013	4	2991.164	2013	4
4/17/2013	5	3362.249	2013	4
4/17/2013	6	3612.661	2013	4
4/17/2013	7	3689.566	2013	4
4/17/2013	8	3810.466	2013	4
4/17/2013	9	3895.366	2013	4
4/17/2013	10	3957.166	2013	4
4/17/2013	11	4017.466	2013	4
4/17/2013	12	4140.266	2013	4
4/17/2013	13	4160.266	2013	4
4/17/2013	14	4176.866	2013	4
4/17/2013	15	4127.166	2013	4
4/17/2013	16	4058.766	2013	4
4/17/2013	17	4043.466	2013	4
4/17/2013	18	3985.465	2013	4
4/17/2013	19	4012.565	2013	4
4/17/2013	20	4025.45	2013	4
4/17/2013	21	3749.318	2013	4
4/17/2013	22	3477.964	2013	4
4/17/2013	23	3258.665	2013	4
4/18/2013	0	3115.765	2013	4
4/18/2013	1	3011.965	2013	4
4/18/2013	2	2916.565	2013	4
4/18/2013	3	2915.965	2013	4
4/18/2013	4	3073.665	2013	4
4/18/2013	5	3486.765	2013	4
4/18/2013	6	3641.266	2013	4
4/18/2013	7	3772.749	2013	4
4/18/2013	8	3921.263	2013	4
4/18/2013	9	4080.166	2013	4
4/18/2013	10	4195.166	2013	4
4/18/2013	11	4280.767	2013	4
4/18/2013	12	4392.566	2013	4
4/18/2013	13	4419.066	2013	4
4/18/2013	14	4484.966	2013	4
4/18/2013	15	4435.566	2013	4
4/18/2013	16	4372.666	2013	4
4/18/2013	17	4320.867	2013	4
4/18/2013	18	4174.866	2013	4
4/18/2013	19	4331.165	2013	4
4/18/2013	20	4294.88	2013	4
4/18/2013	21	3983.465	2013	4
4/18/2013	22	3675.265	2013	4
4/18/2013	23	3420.065	2013	4
4/19/2013	0	3223.065	2013	4
4/19/2013	1	3134.764	2013	4
4/19/2013	2	2988.359	2013	4
4/19/2013	3	2947.148	2013	4
4/19/2013	4	3026.464	2013	4
4/19/2013	5	3341.063	2013	4

Day	Hr	Total	Year	Month
4/19/2013	6	3513.864	2013	4
4/19/2013	7	3577.864	2013	4
4/19/2013	8	3650.164	2013	4
4/19/2013	9	3780.852	2013	4
4/19/2013	10	3771.134	2013	4
4/19/2013	11	3790.164	2013	4
4/19/2013	12	3807.464	2013	4
4/19/2013	13	3800.465	2013	4
4/19/2013	14	3752.764	2013	4
4/19/2013	15	3734.954	2013	4
4/19/2013	16	3732.256	2013	4
4/19/2013	17	3708.364	2013	4
4/19/2013	18	3734.864	2013	4
4/19/2013	19	3803.863	2013	4
4/19/2013	20	3865.253	2013	4
4/19/2013	21	3651.454	2013	4
4/19/2013	22	3496.662	2013	4
4/19/2013	23	3357.962	2013	4
4/20/2013	0	3202.462	2013	4
4/20/2013	1	3118.949	2013	4
4/20/2013	2	3128.557	2013	4
4/20/2013	3	3152.261	2013	4
4/20/2013	4	3218.761	2013	4
4/20/2013	5	3399.054	2013	4
4/20/2013	6	3490.252	2013	4
4/20/2013	7	3572.563	2013	4
4/20/2013	8	3515.263	2013	4
4/20/2013	9	3467.764	2013	4
4/20/2013	10	3453.665	2013	4
4/20/2013	11	3364.65	2013	4
4/20/2013	12	3324.764	2013	4
4/20/2013	13	3109.305	2013	4
4/20/2013	14	3107.565	2013	4
4/20/2013	15	3098.166	2013	4
4/20/2013	16	3079.665	2013	4
4/20/2013	17	3056.266	2013	4
4/20/2013	18	3046.955	2013	4
4/20/2013	19	3244.658	2013	4
4/20/2013	20	3312.164	2013	4
4/20/2013	21	3196.363	2013	4
4/20/2013	22	3076.264	2013	4
4/20/2013	23	2943.352	2013	4
4/21/2013	0	2850.756	2013	4
4/21/2013	1	2904.162	2013	4
4/21/2013	2	2860.563	2013	4
4/21/2013	3	2903.16	2013	4
4/21/2013	4	2983.746	2013	4
4/21/2013	5	3136.562	2013	4
4/21/2013	6	3233.163	2013	4
4/21/2013	7	3327.064	2013	4
4/21/2013	8	3305.858	2013	4
4/21/2013	9	3259.954	2013	4
4/21/2013	10	3204.565	2013	4
4/21/2013	11	3132.665	2013	4
4/21/2013	12	3106.166	2013	4
4/21/2013	13	3063.865	2013	4
4/21/2013	14	2975.466	2013	4
4/21/2013	15	3073.563	2013	4
4/21/2013	16	3007.952	2013	4
4/21/2013	17	3097.266	2013	4
4/21/2013	18	3054.665	2013	4
4/21/2013	19	3338.865	2013	4
4/21/2013	20	3376.065	2013	4
4/21/2013	21	3222.563	2013	4

Day	Hr	Total	Year	Month
4/21/2013	22	3016.053	2013	4
4/21/2013	23	2913.057	2013	4
4/22/2013	0	2849.563	2013	4
4/22/2013	1	2841.563	2013	4
4/22/2013	2	2857.364	2013	4
4/22/2013	3	2998.154	2013	4
4/22/2013	4	3215.854	2013	4
4/22/2013	5	3673.163	2013	4
4/22/2013	6	3852.463	2013	4
4/22/2013	7	3882.364	2013	4
4/22/2013	8	3815.163	2013	4
4/22/2013	9	3808.051	2013	4
4/22/2013	10	3769.666	2013	4
4/22/2013	11	3775.964	2013	4
4/22/2013	12	3837.965	2013	4
4/22/2013	13	3813.366	2013	4
4/22/2013	14	3799.767	2013	4
4/22/2013	15	3770.765	2013	4
4/22/2013	16	3761.567	2013	4
4/22/2013	17	3751.366	2013	4
4/22/2013	18	3717.066	2013	4
4/22/2013	19	3812.665	2013	4
4/22/2013	20	3833.859	2013	4
4/22/2013	21	3549.452	2013	4
4/22/2013	22	3288.365	2013	4
4/22/2013	23	3094.264	2013	4
4/23/2013	0	2985.764	2013	4
4/23/2013	1	2870.766	2013	4
4/23/2013	2	2842.366	2013	4
4/23/2013	3	2857.465	2013	4
4/23/2013	4	3043.857	2013	4
4/23/2013	5	3415.157	2013	4
4/23/2013	6	3641.966	2013	4
4/23/2013	7	3615.267	2013	4
4/23/2013	8	3691.667	2013	4
4/23/2013	9	3689.667	2013	4
4/23/2013	10	3678.167	2013	4
4/23/2013	11	3705.567	2013	4
4/23/2013	12	3743.267	2013	4
4/23/2013	13	3802.068	2013	4
4/23/2013	14	3772.967	2013	4
4/23/2013	15	3713.762	2013	4
4/23/2013	16	3699.854	2013	4
4/23/2013	17	3648.068	2013	4
4/23/2013	18	3616.367	2013	4
4/23/2013	19	3761.667	2013	4
4/23/2013	20	3806.166	2013	4
4/23/2013	21	3545.766	2013	4
4/23/2013	22	3327.667	2013	4
4/23/2013	23	3074.066	2013	4
4/24/2013	0	2953.066	2013	4
4/24/2013	1	2893.466	2013	4
4/24/2013	2	2765.766	2013	4
4/24/2013	3	2806.767	2013	4
4/24/2013	4	2999.766	2013	4
4/24/2013	5	3384.061	2013	4
4/24/2013	6	3614.852	2013	4
4/24/2013	7	3671.667	2013	4
4/24/2013	8	3755.167	2013	4
4/24/2013	9	3813.467	2013	4
4/24/2013	10	3833.066	2013	4
4/24/2013	11	3844.667	2013	4
4/24/2013	12	3842.167	2013	4
4/24/2013	13	3843.366	2013	4

Day	Hr	Total	Year	Month
4/24/2013	14	3790.066	2013	4
4/24/2013	15	3805.87	2013	4
4/24/2013	16	3803.365	2013	4
4/24/2013	17	3808.266	2013	4
4/24/2013	18	3829.067	2013	4
4/24/2013	19	3894.866	2013	4
4/24/2013	20	3927.765	2013	4
4/24/2013	21	3741.365	2013	4
4/24/2013	22	3507.463	2013	4
4/24/2013	23	3326.049	2013	4
4/25/2013	0	3250.165	2013	4
4/25/2013	1	3229.364	2013	4
4/25/2013	2	3218.765	2013	4
4/25/2013	3	3301.064	2013	4
4/25/2013	4	3539.165	2013	4
4/25/2013	5	3913.465	2013	4
4/25/2013	6	4099.048	2013	4
4/25/2013	7	4040.865	2013	4
4/25/2013	8	3953.667	2013	4
4/25/2013	9	3922.666	2013	4
4/25/2013	10	3855.966	2013	4
4/25/2013	11	3744.667	2013	4
4/25/2013	12	3732.067	2013	4
4/25/2013	13	3720.167	2013	4
4/25/2013	14	3660.763	2013	4
4/25/2013	15	3619.854	2013	4
4/25/2013	16	3578.966	2013	4
4/25/2013	17	3545.867	2013	4
4/25/2013	18	3487.767	2013	4
4/25/2013	19	3664.067	2013	4
4/25/2013	20	3731.666	2013	4
4/25/2013	21	3499.865	2013	4
4/25/2013	22	3365.066	2013	4
4/25/2013	23	3198.165	2013	4
4/26/2013	0	3064.449	2013	4
4/26/2013	1	3107.063	2013	4
4/26/2013	2	3033.552	2013	4
4/26/2013	3	3113.465	2013	4
4/26/2013	4	3355.265	2013	4
4/26/2013	5	3719.765	2013	4
4/26/2013	6	3842.866	2013	4
4/26/2013	7	3863.259	2013	4
4/26/2013	8	3794.956	2013	4
4/26/2013	9	3742.867	2013	4
4/26/2013	10	3697.466	2013	4
4/26/2013	11	3699.667	2013	4
4/26/2013	12	3679.567	2013	4
4/26/2013	13	3673.967	2013	4
4/26/2013	14	3612.767	2013	4
4/26/2013	15	3518.767	2013	4
4/26/2013	16	3500.867	2013	4
4/26/2013	17	3449.567	2013	4
4/26/2013	18	3417.567	2013	4
4/26/2013	19	3548.558	2013	4
4/26/2013	20	3560.757	2013	4
4/26/2013	21	3351.165	2013	4
4/26/2013	22	3161.766	2013	4
4/26/2013	23	2967.266	2013	4
4/27/2013	0	2854.266	2013	4
4/27/2013	1	2778.666	2013	4
4/27/2013	2	2745.166	2013	4
4/27/2013	3	2719.766	2013	4
4/27/2013	4	2804.865	2013	4
4/27/2013	5	2930.053	2013	4

Day	Hr	Total	Year	Month
4/27/2013	6	3012.362	2013	4
4/27/2013	7	3183.066	2013	4
4/27/2013	8	3297.767	2013	4
4/27/2013	9	3365.767	2013	4
4/27/2013	10	3390.867	2013	4
4/27/2013	11	3387.066	2013	4
4/27/2013	12	3365.367	2013	4
4/27/2013	13	3234.767	2013	4
4/27/2013	14	3239.767	2013	4
4/27/2013	15	3254.459	2013	4
4/27/2013	16	3308.156	2013	4
4/27/2013	17	3295.567	2013	4
4/27/2013	18	3276.967	2013	4
4/27/2013	19	3381.367	2013	4
4/27/2013	20	3327.365	2013	4
4/27/2013	21	3189.666	2013	4
4/27/2013	22	2987.666	2013	4
4/27/2013	23	2797.665	2013	4
4/28/2013	0	2733.766	2013	4
4/28/2013	1	2658.962	2013	4
4/28/2013	2	2556.799	2013	4
4/28/2013	3	2571.966	2013	4
4/28/2013	4	2592.266	2013	4
4/28/2013	5	2695.866	2013	4
4/28/2013	6	2751.567	2013	4
4/28/2013	7	2916.467	2013	4
4/28/2013	8	3037.067	2013	4
4/28/2013	9	3099.667	2013	4
4/28/2013	10	3086.367	2013	4
4/28/2013	11	3114.867	2013	4
4/28/2013	12	3090.965	2013	4
4/28/2013	13	3073.45	2013	4
4/28/2013	14	3099.467	2013	4
4/28/2013	15	3104.196	2013	4
4/28/2013	16	3178.567	2013	4
4/28/2013	17	3141.867	2013	4
4/28/2013	18	3180.767	2013	4
4/28/2013	19	3291.667	2013	4
4/28/2013	20	3329.066	2013	4
4/28/2013	21	3163.966	2013	4
4/28/2013	22	2967.765	2013	4
4/28/2013	23	2820.367	2013	4
4/29/2013	0	2713.461	2013	4
4/29/2013	1	2693.849	2013	4
4/29/2013	2	2701.265	2013	4
4/29/2013	3	2737.466	2013	4
4/29/2013	4	2898.767	2013	4
4/29/2013	5	3312.466	2013	4
4/29/2013	6	3528.566	2013	4
4/29/2013	7	3608.768	2013	4
4/29/2013	8	3694.967	2013	4
4/29/2013	9	3745.767	2013	4
4/29/2013	10	3750.565	2013	4
4/29/2013	11	3757.868	2013	4
4/29/2013	12	3778.367	2013	4
4/29/2013	13	3776.255	2013	4
4/29/2013	14	3753.661	2013	4
4/29/2013	15	3700.666	2013	4
4/29/2013	16	3638.768	2013	4
4/29/2013	17	3631.867	2013	4
4/29/2013	18	3640.967	2013	4
4/29/2013	19	3766.667	2013	4
4/29/2013	20	3818.366	2013	4
4/29/2013	21	3559.966	2013	4

Day	Hr	Total	Year	Month
4/29/2013	22	3277.767	2013	4
4/29/2013	23	3075.965	2013	4
4/30/2013	0	2925.866	2013	4
4/30/2013	1	2888.166	2013	4
4/30/2013	2	2827.265	2013	4
4/30/2013	3	2870.349	2013	4
4/30/2013	4	3065.864	2013	4
4/30/2013	5	3429.166	2013	4
4/30/2013	6	3612.966	2013	4
4/30/2013	7	3658.965	2013	4
4/30/2013	8	3719.367	2013	4
4/30/2013	9	3754.067	2013	4
4/30/2013	10	3839.173	2013	4
4/30/2013	11	3897.173	2013	4
4/30/2013	12	4022.774	2013	4
4/30/2013	13	4057.575	2013	4
4/30/2013	14	4110.077	2013	4
4/30/2013	15	4139.376	2013	4
4/30/2013	16	4141.175	2013	4
4/30/2013	17	4162.474	2013	4
4/30/2013	18	4117.475	2013	4
4/30/2013	19	4140.173	2013	4
4/30/2013	20	4139.372	2013	4
4/30/2013	21	3827.266	2013	4
4/30/2013	22	3518.256	2013	4
4/30/2013	23	3242.557	2013	4
5/1/2013	0	3045.567	2013	5
5/1/2013	1	2908.666	2013	5
5/1/2013	2	2797.967	2013	5
5/1/2013	3	2812.366	2013	5
5/1/2013	4	2969.566	2013	5
5/1/2013	5	3354.767	2013	5
5/1/2013	6	3526.268	2013	5
5/1/2013	7	3712.267	2013	5
5/1/2013	8	3805.069	2013	5
5/1/2013	9	3955.974	2013	5
5/1/2013	10	4096.674	2013	5
5/1/2013	11	4203.477	2013	5
5/1/2013	12	4396.178	2013	5
5/1/2013	13	4395.878	2013	5
5/1/2013	14	4477.077	2013	5
5/1/2013	15	4458.378	2013	5
5/1/2013	16	4471.74	2013	5
5/1/2013	17	4410.659	2013	5
5/1/2013	18	4329.278	2013	5
5/1/2013	19	4371.678	2013	5
5/1/2013	20	4323.876	2013	5
5/1/2013	21	4056.175	2013	5
5/1/2013	22	3684.673	2013	5
5/1/2013	23	3386.054	2013	5
5/2/2013	0	3165.567	2013	5
5/2/2013	1	3047.471	2013	5
5/2/2013	2	2897.67	2013	5
5/2/2013	3	2887.671	2013	5
5/2/2013	4	3029.27	2013	5
5/2/2013	5	3428.472	2013	5
5/2/2013	6	3616.571	2013	5
5/2/2013	7	3763.172	2013	5
5/2/2013	8	3862.371	2013	5
5/2/2013	9	4018.676	2013	5
5/2/2013	10	4068.857	2013	5
5/2/2013	11	4166.059	2013	5
5/2/2013	12	4261.059	2013	5
5/2/2013	13	4234.6	2013	5

Day	Hr	Total	Year	Month
5/2/2013	14	4243.119	2013	5
5/2/2013	15	4269.559	2013	5
5/2/2013	16	4221.559	2013	5
5/2/2013	17	4131.859	2013	5
5/2/2013	18	4056.959	2013	5
5/2/2013	19	4161.459	2013	5
5/2/2013	20	4144.958	2013	5
5/2/2013	21	3911.856	2013	5
5/2/2013	22	3570.851	2013	5
5/2/2013	23	3307.452	2013	5
5/3/2013	0	3147.951	2013	5
5/3/2013	1	3002.251	2013	5
5/3/2013	2	2872.352	2013	5
5/3/2013	3	2871.751	2013	5
5/3/2013	4	3001.351	2013	5
5/3/2013	5	3300.952	2013	5
5/3/2013	6	3484.352	2013	5
5/3/2013	7	3649.052	2013	5
5/3/2013	8	3790.352	2013	5
5/3/2013	9	3931.652	2013	5
5/3/2013	10	4022.552	2013	5
5/3/2013	11	4113.353	2013	5
5/3/2013	12	4138.552	2013	5
5/3/2013	13	4139.052	2013	5
5/3/2013	14	4159.852	2013	5
5/3/2013	15	4119.352	2013	5
5/3/2013	16	4039.853	2013	5
5/3/2013	17	3918.452	2013	5
5/3/2013	18	3797.052	2013	5
5/3/2013	19	3829.552	2013	5
5/3/2013	20	3818.251	2013	5
5/3/2013	21	3613.951	2013	5
5/3/2013	22	3351.651	2013	5
5/3/2013	23	3130.251	2013	5
5/4/2013	0	2966.152	2013	5
5/4/2013	1	2843.351	2013	5
5/4/2013	2	2751.451	2013	5
5/4/2013	3	2688.751	2013	5
5/4/2013	4	2677.551	2013	5
5/4/2013	5	2794.651	2013	5
5/4/2013	6	2823.552	2013	5
5/4/2013	7	3026.352	2013	5
5/4/2013	8	3171.652	2013	5
5/4/2013	9	3262.652	2013	5
5/4/2013	10	3318.864	2013	5
5/4/2013	11	3313.769	2013	5
5/4/2013	12	3321.268	2013	5
5/4/2013	13	3290.366	2013	5
5/4/2013	14	3235.656	2013	5
5/4/2013	15	3205.853	2013	5
5/4/2013	16	3196.166	2013	5
5/4/2013	17	3133.565	2013	5
5/4/2013	18	3104.166	2013	5
5/4/2013	19	3183.766	2013	5
5/4/2013	20	3210.765	2013	5
5/4/2013	21	3049.964	2013	5
5/4/2013	22	2922.854	2013	5
5/4/2013	23	2669.857	2013	5
5/5/2013	0	2564.265	2013	5
5/5/2013	1	2597.064	2013	5
5/5/2013	2	2507.365	2013	5
5/5/2013	3	2541.964	2013	5
5/5/2013	4	2561.88	2013	5
5/5/2013	5	2659.248	2013	5

Day	Hr	Total	Year	Month
5/5/2013	6	2681.564	2013	5
5/5/2013	7	2859.266	2013	5
5/5/2013	8	3066.066	2013	5
5/5/2013	9	3118.465	2013	5
5/5/2013	10	3177.566	2013	5
5/5/2013	11	3246.357	2013	5
5/5/2013	12	3217.957	2013	5
5/5/2013	13	3225.266	2013	5
5/5/2013	14	3199.565	2013	5
5/5/2013	15	3201.9	2013	5
5/5/2013	16	3169.065	2013	5
5/5/2013	17	3285.965	2013	5
5/5/2013	18	3247.949	2013	5
5/5/2013	19	3392.464	2013	5
5/5/2013	20	3386.764	2013	5
5/5/2013	21	3198.164	2013	5
5/5/2013	22	2964.365	2013	5
5/5/2013	23	2808.263	2013	5
5/6/2013	0	2734.148	2013	5
5/6/2013	1	2805.264	2013	5
5/6/2013	2	2769.565	2013	5
5/6/2013	3	2840.665	2013	5
5/6/2013	4	3013.864	2013	5
5/6/2013	5	3419.465	2013	5
5/6/2013	6	3673.055	2013	5
5/6/2013	7	3752.659	2013	5
5/6/2013	8	3826.166	2013	5
5/6/2013	9	3878.367	2013	5
5/6/2013	10	3848.169	2013	5
5/6/2013	11	3863.11	2013	5
5/6/2013	12	3866.47	2013	5
5/6/2013	13	3735.366	2013	5
5/6/2013	14	3698.457	2013	5
5/6/2013	15	3675.871	2013	5
5/6/2013	16	3675.37	2013	5
5/6/2013	17	3672.171	2013	5
5/6/2013	18	3660.17	2013	5
5/6/2013	19	3792.568	2013	5
5/6/2013	20	3734.265	2013	5
5/6/2013	21	3547.355	2013	5
5/6/2013	22	3271.457	2013	5
5/6/2013	23	3084.165	2013	5
5/7/2013	0	2973.665	2013	5
5/7/2013	1	2868.965	2013	5
5/7/2013	2	2862.066	2013	5
5/7/2013	3	2880.765	2013	5
5/7/2013	4	3040.254	2013	5
5/7/2013	5	3407.158	2013	5
5/7/2013	6	3627.867	2013	5
5/7/2013	7	3707.266	2013	5
5/7/2013	8	3795.969	2013	5
5/7/2013	9	3894.77	2013	5
5/7/2013	10	3889.371	2013	5
5/7/2013	11	3937.07	2013	5
5/7/2013	12	3920.67	2013	5
5/7/2013	13	3885.071	2013	5
5/7/2013	14	3881.414	2013	5
5/7/2013	15	3814.86	2013	5
5/7/2013	16	3830.771	2013	5
5/7/2013	17	3828.47	2013	5
5/7/2013	18	3786.171	2013	5
5/7/2013	19	3937.07	2013	5
5/7/2013	20	3899.57	2013	5
5/7/2013	21	3678.969	2013	5

Day	Hr	Total	Year	Month
5/7/2013	22	3418.27	2013	5
5/7/2013	23	3211.069	2013	5
5/8/2013	0	3040.557	2013	5
5/8/2013	1	2942.961	2013	5
5/8/2013	2	2880.368	2013	5
5/8/2013	3	2870.767	2013	5
5/8/2013	4	3029.665	2013	5
5/8/2013	5	3342.165	2013	5
5/8/2013	6	3618.467	2013	5
5/8/2013	7	3717.763	2013	5
5/8/2013	8	3780.86	2013	5
5/8/2013	9	3911.371	2013	5
5/8/2013	10	3961.87	2013	5
5/8/2013	11	4025.371	2013	5
5/8/2013	12	4138.171	2013	5
5/8/2013	13	4082.571	2013	5
5/8/2013	14	4121.27	2013	5
5/8/2013	15	4117.171	2013	5
5/8/2013	16	4045.671	2013	5
5/8/2013	17	4027.07	2013	5
5/8/2013	18	3940.671	2013	5
5/8/2013	19	4007.071	2013	5
5/8/2013	20	3999.369	2013	5
5/8/2013	21	3756.77	2013	5
5/8/2013	22	3475.475	2013	5
5/8/2013	23	3218.465	2013	5
5/9/2013	0	3024.27	2013	5
5/9/2013	1	2945.37	2013	5
5/9/2013	2	2876.567	2013	5
5/9/2013	3	2821.069	2013	5
5/9/2013	4	2999.068	2013	5
5/9/2013	5	3361.568	2013	5
5/9/2013	6	3596.853	2013	5
5/9/2013	7	3715.967	2013	5
5/9/2013	8	3864.972	2013	5
5/9/2013	9	3957.672	2013	5
5/9/2013	10	4126.377	2013	5
5/9/2013	11	4217.178	2013	5
5/9/2013	12	4344.779	2013	5
5/9/2013	13	4366.778	2013	5
5/9/2013	14	4367.979	2013	5
5/9/2013	15	4376.878	2013	5
5/9/2013	16	4287.377	2013	5
5/9/2013	17	4226.976	2013	5
5/9/2013	18	4133.475	2013	5
5/9/2013	19	4231.877	2013	5
5/9/2013	20	4198.571	2013	5
5/9/2013	21	3975.871	2013	5
5/9/2013	22	3619.471	2013	5
5/9/2013	23	3293.871	2013	5
5/10/2013	0	3114.771	2013	5
5/10/2013	1	2994.871	2013	5
5/10/2013	2	2920.47	2013	5
5/10/2013	3	2900.955	2013	5
5/10/2013	4	3034.367	2013	5
5/10/2013	5	3356.472	2013	5
5/10/2013	6	3591.772	2013	5
5/10/2013	7	3726.472	2013	5
5/10/2013	8	3852.271	2013	5
5/10/2013	9	3927.672	2013	5
5/10/2013	10	3956.872	2013	5
5/10/2013	11	3952.771	2013	5
5/10/2013	12	3920.671	2013	5
5/10/2013	13	3881.871	2013	5

Day	Hr	Total	Year	Month
5/10/2013	14	3812.871	2013	5
5/10/2013	15	3718.372	2013	5
5/10/2013	16	3699.071	2013	5
5/10/2013	17	3660.971	2013	5
5/10/2013	18	3588.971	2013	5
5/10/2013	19	3646.069	2013	5
5/10/2013	20	3691.654	2013	5
5/10/2013	21	3511.968	2013	5
5/10/2013	22	3289.771	2013	5
5/10/2013	23	3097.57	2013	5
5/11/2013	0	2914.971	2013	5
5/11/2013	1	2806.47	2013	5
5/11/2013	2	2716.47	2013	5
5/11/2013	3	2652.371	2013	5
5/11/2013	4	2674.37	2013	5
5/11/2013	5	2776.67	2013	5
5/11/2013	6	2809.871	2013	5
5/11/2013	7	2969.871	2013	5
5/11/2013	8	3126.771	2013	5
5/11/2013	9	3222.472	2013	5
5/11/2013	10	3249.256	2013	5
5/11/2013	11	3218.565	2013	5
5/11/2013	12	3257.771	2013	5
5/11/2013	13	3173.871	2013	5
5/11/2013	14	3187.171	2013	5
5/11/2013	15	3146.872	2013	5
5/11/2013	16	3174.671	2013	5
5/11/2013	17	3165.571	2013	5
5/11/2013	18	3122.271	2013	5
5/11/2013	19	3171.971	2013	5
5/11/2013	20	3256.07	2013	5
5/11/2013	21	3136.17	2013	5
5/11/2013	22	2927.171	2013	5
5/11/2013	23	2755.569	2013	5
5/12/2013	0	2624.956	2013	5
5/12/2013	1	2563.264	2013	5
5/12/2013	2	2501.77	2013	5
5/12/2013	3	2502.87	2013	5
5/12/2013	4	2580.569	2013	5
5/12/2013	5	2573.871	2013	5
5/12/2013	6	2658.171	2013	5
5/12/2013	7	2884.87	2013	5
5/12/2013	8	2960.671	2013	5
5/12/2013	9	3089.964	2013	5
5/12/2013	10	3010.46	2013	5
5/12/2013	11	2984.971	2013	5
5/12/2013	12	2942.771	2013	5
5/12/2013	13	2899.171	2013	5
5/12/2013	14	2899.371	2013	5
5/12/2013	15	2902.972	2013	5
5/12/2013	16	2927.371	2013	5
5/12/2013	17	2897.471	2013	5
5/12/2013	18	2989.071	2013	5
5/12/2013	19	3101.471	2013	5
5/12/2013	20	3306.671	2013	5
5/12/2013	21	3180.967	2013	5
5/12/2013	22	2917.853	2013	5
5/12/2013	23	2844.669	2013	5
5/13/2013	0	2738.025	2013	5
5/13/2013	1	2793.769	2013	5
5/13/2013	2	2776.97	2013	5
5/13/2013	3	2855.569	2013	5
5/13/2013	4	3083.479	2013	5
5/13/2013	5	3530.17	2013	5

Day	Hr	Total	Year	Month
5/13/2013	6	3773.262	2013	5
5/13/2013	7	3850.86	2013	5
5/13/2013	8	3799.57	2013	5
5/13/2013	9	3816.771	2013	5
5/13/2013	10	3748.77	2013	5
5/13/2013	11	3794.171	2013	5
5/13/2013	12	3789.371	2013	5
5/13/2013	13	3710.371	2013	5
5/13/2013	14	3693.271	2013	5
5/13/2013	15	3641.47	2013	5
5/13/2013	16	3611.672	2013	5
5/13/2013	17	3588.771	2013	5
5/13/2013	18	3573.771	2013	5
5/13/2013	19	3647.571	2013	5
5/13/2013	20	3760.962	2013	5
5/13/2013	21	3533.158	2013	5
5/13/2013	22	3247.27	2013	5
5/13/2013	23	3124.67	2013	5
5/14/2013	0	2976.071	2013	5
5/14/2013	1	2932.369	2013	5
5/14/2013	2	2879.77	2013	5
5/14/2013	3	2938.37	2013	5
5/14/2013	4	3111.469	2013	5
5/14/2013	5	3501.671	2013	5
5/14/2013	6	3731.862	2013	5
5/14/2013	7	3747.961	2013	5
5/14/2013	8	3792.471	2013	5
5/14/2013	9	3813.87	2013	5
5/14/2013	10	3810.471	2013	5
5/14/2013	11	3835.571	2013	5
5/14/2013	12	3893.972	2013	5
5/14/2013	13	3894.378	2013	5
5/14/2013	14	3991.277	2013	5
5/14/2013	15	4047.577	2013	5
5/14/2013	16	4113.677	2013	5
5/14/2013	17	4166.378	2013	5
5/14/2013	18	4149.777	2013	5
5/14/2013	19	4202.377	2013	5
5/14/2013	20	4246.873	2013	5
5/14/2013	21	3975.07	2013	5
5/14/2013	22	3665.97	2013	5
5/14/2013	23	3421.17	2013	5
5/15/2013	0	3207.671	2013	5
5/15/2013	1	3073.07	2013	5
5/15/2013	2	3011.77	2013	5
5/15/2013	3	2926.57	2013	5
5/15/2013	4	3083.966	2013	5
5/15/2013	5	3408.255	2013	5
5/15/2013	6	3652.77	2013	5
5/15/2013	7	3869.372	2013	5
5/15/2013	8	4033.776	2013	5
5/15/2013	9	4253.578	2013	5
5/15/2013	10	4453.973	2013	5
5/15/2013	11	4608.568	2013	5
5/15/2013	12	4753.466	2013	5
5/15/2013	13	4790.361	2013	5
5/15/2013	14	4863.153	2013	5
5/15/2013	15	4904.356	2013	5
5/15/2013	16	4903.957	2013	5
5/15/2013	17	4854.698	2013	5
5/15/2013	18	4725.356	2013	5
5/15/2013	19	4639.632	2013	5
5/15/2013	20	4581.755	2013	5
5/15/2013	21	4247.556	2013	5

Day	Hr	Total	Year	Month
5/15/2013	22	3859.255	2013	5
5/15/2013	23	3553.851	2013	5
5/16/2013	0	3312.348	2013	5
5/16/2013	1	3177.25	2013	5
5/16/2013	2	3010.149	2013	5
5/16/2013	3	2984.849	2013	5
5/16/2013	4	3113.248	2013	5
5/16/2013	5	3432.849	2013	5
5/16/2013	6	3692.449	2013	5
5/16/2013	7	3863.05	2013	5
5/16/2013	8	3973.55	2013	5
5/16/2013	9	4099.949	2013	5
5/16/2013	10	4094.849	2013	5
5/16/2013	11	4220.05	2013	5
5/16/2013	12	4242.05	2013	5
5/16/2013	13	4223.049	2013	5
5/16/2013	14	4210.75	2013	5
5/16/2013	15	4192.65	2013	5
5/16/2013	16	4151.65	2013	5
5/16/2013	17	4122.049	2013	5
5/16/2013	18	4053.25	2013	5
5/16/2013	19	4106.65	2013	5
5/16/2013	20	4100.149	2013	5
5/16/2013	21	3862.049	2013	5
5/16/2013	22	3617.846	2013	5
5/16/2013	23	3349.849	2013	5
5/17/2013	0	3149.35	2013	5
5/17/2013	1	2967.625	2013	5
5/17/2013	2	2911.848	2013	5
5/17/2013	3	2928.848	2013	5
5/17/2013	4	3048.248	2013	5
5/17/2013	5	3397.349	2013	5
5/17/2013	6	3588.55	2013	5
5/17/2013	7	3717.45	2013	5
5/17/2013	8	3897.05	2013	5
5/17/2013	9	4020.25	2013	5
5/17/2013	10	4138.05	2013	5
5/17/2013	11	4229.349	2013	5
5/17/2013	12	4283.45	2013	5
5/17/2013	13	4256.752	2013	5
5/17/2013	14	4287.068	2013	5
5/17/2013	15	4241.468	2013	5
5/17/2013	16	4179.668	2013	5
5/17/2013	17	4056.968	2013	5
5/17/2013	18	3936.568	2013	5
5/17/2013	19	3947.168	2013	5
5/17/2013	20	3980.567	2013	5
5/17/2013	21	3802.268	2013	5
5/17/2013	22	3559.969	2013	5
5/17/2013	23	3303.368	2013	5
5/18/2013	0	3132.068	2013	5
5/18/2013	1	2983.662	2013	5
5/18/2013	2	2907.654	2013	5
5/18/2013	3	2828.369	2013	5
5/18/2013	4	2849.467	2013	5
5/18/2013	5	2970.269	2013	5
5/18/2013	6	3045.769	2013	5
5/18/2013	7	3141.569	2013	5
5/18/2013	8	3401.068	2013	5
5/18/2013	9	3637.58	2013	5
5/18/2013	10	3711.968	2013	5
5/18/2013	11	3770.369	2013	5
5/18/2013	12	3815.468	2013	5
5/18/2013	13	3913.768	2013	5

Day	Hr	Total	Year	Month
5/18/2013	14	3886.768	2013	5
5/18/2013	15	3971.368	2013	5
5/18/2013	16	4013.567	2013	5
5/18/2013	17	4062.366	2013	5
5/18/2013	18	3953.669	2013	5
5/18/2013	19	3876.668	2013	5
5/18/2013	20	3899.257	2013	5
5/18/2013	21	3719.753	2013	5
5/18/2013	22	3448.268	2013	5
5/18/2013	23	3178.167	2013	5
5/19/2013	0	3011.468	2013	5
5/19/2013	1	2863.469	2013	5
5/19/2013	2	2728.668	2013	5
5/19/2013	3	2664.766	2013	5
5/19/2013	4	2695.467	2013	5
5/19/2013	5	2691.466	2013	5
5/19/2013	6	2772.663	2013	5
5/19/2013	7	2999.953	2013	5
5/19/2013	8	3259.668	2013	5
5/19/2013	9	3470.868	2013	5
5/19/2013	10	3753.169	2013	5
5/19/2013	11	3989.368	2013	5
5/19/2013	12	4148.002	2013	5
5/19/2013	13	4299.575	2013	5
5/19/2013	14	4441.475	2013	5
5/19/2013	15	4520.776	2013	5
5/19/2013	16	4591.174	2013	5
5/19/2013	17	4568.876	2013	5
5/19/2013	18	4536.974	2013	5
5/19/2013	19	4427.371	2013	5
5/19/2013	20	4496.468	2013	5
5/19/2013	21	4209.567	2013	5
5/19/2013	22	3917.067	2013	5
5/19/2013	23	3606.367	2013	5
5/20/2013	0	3339.464	2013	5
5/20/2013	1	3242.051	2013	5
5/20/2013	2	3122.665	2013	5
5/20/2013	3	3075.467	2013	5
5/20/2013	4	3216.968	2013	5
5/20/2013	5	3552.169	2013	5
5/20/2013	6	3785.069	2013	5
5/20/2013	7	4032.468	2013	5
5/20/2013	8	4317.269	2013	5
5/20/2013	9	4516.968	2013	5
5/20/2013	10	4725.968	2013	5
5/20/2013	11	4957.668	2013	5
5/20/2013	12	5111.669	2013	5
5/20/2013	13	5233.674	2013	5
5/20/2013	14	5345.276	2013	5
5/20/2013	15	5414.675	2013	5
5/20/2013	16	5392.676	2013	5
5/20/2013	17	5364.474	2013	5
5/20/2013	18	5218.573	2013	5
5/20/2013	19	5096.368	2013	5
5/20/2013	20	5012.967	2013	5
5/20/2013	21	4710.168	2013	5
5/20/2013	22	4290.967	2013	5
5/20/2013	23	3918.667	2013	5
5/21/2013	0	3694.467	2013	5
5/21/2013	1	3459.751	2013	5
5/21/2013	2	3362.661	2013	5
5/21/2013	3	3310.968	2013	5
5/21/2013	4	3449.267	2013	5
5/21/2013	5	3709.668	2013	5

Day	Hr	Total	Year	Month
5/21/2013	6	3957.468	2013	5
5/21/2013	7	4102.868	2013	5
5/21/2013	8	4254.169	2013	5
5/21/2013	9	4473.868	2013	5
5/21/2013	10	4621.168	2013	5
5/21/2013	11	4842.369	2013	5
5/21/2013	12	5048.568	2013	5
5/21/2013	13	5144.57	2013	5
5/21/2013	14	5191.673	2013	5
5/21/2013	15	5123.871	2013	5
5/21/2013	16	4874.672	2013	5
5/21/2013	17	4723.771	2013	5
5/21/2013	18	4591.568	2013	5
5/21/2013	19	4452.368	2013	5
5/21/2013	20	4430.568	2013	5
5/21/2013	21	4127.767	2013	5
5/21/2013	22	3768.568	2013	5
5/21/2013	23	3480.251	2013	5
5/22/2013	0	3315.96	2013	5
5/22/2013	1	3183.967	2013	5
5/22/2013	2	3070.467	2013	5
5/22/2013	3	3028.568	2013	5
5/22/2013	4	3161.268	2013	5
5/22/2013	5	3451.868	2013	5
5/22/2013	6	3734.968	2013	5
5/22/2013	7	3933.169	2013	5
5/22/2013	8	4100.368	2013	5
5/22/2013	9	4330.268	2013	5
5/22/2013	10	4499.169	2013	5
5/22/2013	11	4659.468	2013	5
5/22/2013	12	4688.169	2013	5
5/22/2013	13	4688.668	2013	5
5/22/2013	14	4663.568	2013	5
5/22/2013	15	4598.969	2013	5
5/22/2013	16	4556.867	2013	5
5/22/2013	17	4440.456	2013	5
5/22/2013	18	4368.757	2013	5
5/22/2013	19	4298.168	2013	5
5/22/2013	20	4290.044	2013	5
5/22/2013	21	4044.166	2013	5
5/22/2013	22	3734.368	2013	5
5/22/2013	23	3475.267	2013	5
5/23/2013	0	3260.768	2013	5
5/23/2013	1	3063.768	2013	5
5/23/2013	2	3044.768	2013	5
5/23/2013	3	2980.268	2013	5
5/23/2013	4	3148.453	2013	5
5/23/2013	5	3439.965	2013	5
5/23/2013	6	3664.268	2013	5
5/23/2013	7	3859.568	2013	5
5/23/2013	8	4016.468	2013	5
5/23/2013	9	4189.968	2013	5
5/23/2013	10	4274.968	2013	5
5/23/2013	11	4331.668	2013	5
5/23/2013	12	4286.168	2013	5
5/23/2013	13	4175.567	2013	5
5/23/2013	14	4127.368	2013	5
5/23/2013	15	4048.467	2013	5
5/23/2013	16	3935.568	2013	5
5/23/2013	17	3914.568	2013	5
5/23/2013	18	3829.169	2013	5
5/23/2013	19	3905.754	2013	5
5/23/2013	20	3937.758	2013	5
5/23/2013	21	3695.367	2013	5

Day	Hr	Total	Year	Month
5/23/2013	22	3375.364	2013	5
5/23/2013	23	3140.363	2013	5
5/24/2013	0	2966.064	2013	5
5/24/2013	1	2829.564	2013	5
5/24/2013	2	2764.764	2013	5
5/24/2013	3	2782.763	2013	5
5/24/2013	4	2914.862	2013	5
5/24/2013	5	3144.447	2013	5
5/24/2013	6	3339.863	2013	5
5/24/2013	7	3543.565	2013	5
5/24/2013	8	3613.022	2013	5
5/24/2013	9	3727.766	2013	5
5/24/2013	10	3726.968	2013	5
5/24/2013	11	3746.769	2013	5
5/24/2013	12	3750.368	2013	5
5/24/2013	13	3738.268	2013	5
5/24/2013	14	3707.568	2013	5
5/24/2013	15	3736.868	2013	5
5/24/2013	16	3699.454	2013	5
5/24/2013	17	3661.164	2013	5
5/24/2013	18	3585.469	2013	5
5/24/2013	19	3532.469	2013	5
5/24/2013	20	3579.065	2013	5
5/24/2013	21	3448.664	2013	5
5/24/2013	22	3204.765	2013	5
5/24/2013	23	2984.364	2013	5
5/25/2013	0	2823.964	2013	5
5/25/2013	1	2676.149	2013	5
5/25/2013	2	2663.16	2013	5
5/25/2013	3	2608.463	2013	5
5/25/2013	4	2657.664	2013	5
5/25/2013	5	2667.964	2013	5
5/25/2013	6	2747.865	2013	5
5/25/2013	7	2905.565	2013	5
5/25/2013	8	3015.089	2013	5
5/25/2013	9	3107.965	2013	5
5/25/2013	10	3085.468	2013	5
5/25/2013	11	3077.469	2013	5
5/25/2013	12	3161.068	2013	5
5/25/2013	13	3163.368	2013	5
5/25/2013	14	3217.569	2013	5
5/25/2013	15	3231.268	2013	5
5/25/2013	16	3208.168	2013	5
5/25/2013	17	3149.169	2013	5
5/25/2013	18	3073.669	2013	5
5/25/2013	19	3129.066	2013	5
5/25/2013	20	3190.152	2013	5
5/25/2013	21	3059.766	2013	5
5/25/2013	22	2877.768	2013	5
5/25/2013	23	2708.566	2013	5
5/26/2013	0	2561.765	2013	5
5/26/2013	1	2491.364	2013	5
5/26/2013	2	2444.665	2013	5
5/26/2013	3	2400.164	2013	5
5/26/2013	4	2460.674	2013	5
5/26/2013	5	2504.351	2013	5
5/26/2013	6	2540.161	2013	5
5/26/2013	7	2715.165	2013	5
5/26/2013	8	2869.965	2013	5
5/26/2013	9	2897.467	2013	5
5/26/2013	10	3005.67	2013	5
5/26/2013	11	3007.869	2013	5
5/26/2013	12	3119.169	2013	5
5/26/2013	13	3150.269	2013	5

Day	Hr	Total	Year	Month
5/26/2013	14	3209.568	2013	5
5/26/2013	15	3297.869	2013	5
5/26/2013	16	3381.869	2013	5
5/26/2013	17	3345.068	2013	5
5/26/2013	18	3327.667	2013	5
5/26/2013	19	3266.452	2013	5
5/26/2013	20	3367.367	2013	5
5/26/2013	21	3189.368	2013	5
5/26/2013	22	2963.269	2013	5
5/26/2013	23	2766.568	2013	5
5/27/2013	0	2571.168	2013	5
5/27/2013	1	2486.867	2013	5
5/27/2013	2	2450.366	2013	5
5/27/2013	3	2414.466	2013	5
5/27/2013	4	2440.065	2013	5
5/27/2013	5	2489.165	2013	5
5/27/2013	6	2509.061	2013	5
5/27/2013	7	2705.457	2013	5
5/27/2013	8	2925.369	2013	5
5/27/2013	9	3186.569	2013	5
5/27/2013	10	3429.369	2013	5
5/27/2013	11	3618.168	2013	5
5/27/2013	12	3748.469	2013	5
5/27/2013	13	3897.769	2013	5
5/27/2013	14	4062.275	2013	5
5/27/2013	15	4163.775	2013	5
5/27/2013	16	4252.974	2013	5
5/27/2013	17	4241.574	2013	5
5/27/2013	18	4121.869	2013	5
5/27/2013	19	4110.069	2013	5
5/27/2013	20	4113.167	2013	5
5/27/2013	21	3921.868	2013	5
5/27/2013	22	3638.368	2013	5
5/27/2013	23	3325.567	2013	5
5/28/2013	0	3179.168	2013	5
5/28/2013	1	3027.868	2013	5
5/28/2013	2	2958.768	2013	5
5/28/2013	3	2960.967	2013	5
5/28/2013	4	3097.468	2013	5
5/28/2013	5	3392.656	2013	5
5/28/2013	6	3651.859	2013	5
5/28/2013	7	3945.469	2013	5
5/28/2013	8	4255.568	2013	5
5/28/2013	9	4542.568	2013	5
5/28/2013	10	4809.568	2013	5
5/28/2013	11	4942.569	2013	5
5/28/2013	12	5102.569	2013	5
5/28/2013	13	5143.672	2013	5
5/28/2013	14	5268.076	2013	5
5/28/2013	15	5281.975	2013	5
5/28/2013	16	5254.875	2013	5
5/28/2013	17	5195.574	2013	5
5/28/2013	18	5000.468	2013	5
5/28/2013	19	4910.369	2013	5
5/28/2013	20	4801.467	2013	5
5/28/2013	21	4580.968	2013	5
5/28/2013	22	4136.167	2013	5
5/28/2013	23	3819.268	2013	5
5/29/2013	0	3495.568	2013	5
5/29/2013	1	3309.968	2013	5
5/29/2013	2	3187.366	2013	5
5/29/2013	3	3105.366	2013	5
5/29/2013	4	3234.652	2013	5
5/29/2013	5	3497.365	2013	5

Day	Hr	Total	Year	Month
5/29/2013	6	3794.068	2013	5
5/29/2013	7	4007.369	2013	5
5/29/2013	8	4271.668	2013	5
5/29/2013	9	4595.269	2013	5
5/29/2013	10	4872.168	2013	5
5/29/2013	11	5092.768	2013	5
5/29/2013	12	5284.576	2013	5
5/29/2013	13	5417.276	2013	5
5/29/2013	14	5492.376	2013	5
5/29/2013	15	5514.575	2013	5
5/29/2013	16	5524.576	2013	5
5/29/2013	17	5399.975	2013	5
5/29/2013	18	5298.675	2013	5
5/29/2013	19	5130.974	2013	5
5/29/2013	20	5092.468	2013	5
5/29/2013	21	4783.367	2013	5
5/29/2013	22	4349.267	2013	5
5/29/2013	23	4013.068	2013	5
5/30/2013	0	3711.468	2013	5
5/30/2013	1	3530.652	2013	5
5/30/2013	2	3370.96	2013	5
5/30/2013	3	3343.568	2013	5
5/30/2013	4	3376.167	2013	5
5/30/2013	5	3646.969	2013	5
5/30/2013	6	3837.868	2013	5
5/30/2013	7	4170.768	2013	5
5/30/2013	8	4483.569	2013	5
5/30/2013	9	4726.168	2013	5
5/30/2013	10	5017.569	2013	5
5/30/2013	11	5266.674	2013	5
5/30/2013	12	5492.475	2013	5
5/30/2013	13	5562.376	2013	5
5/30/2013	14	5618.775	2013	5
5/30/2013	15	5653.675	2013	5
5/30/2013	16	5551.375	2013	5
5/30/2013	17	5421.474	2013	5
5/30/2013	18	5195.269	2013	5
5/30/2013	19	5046.968	2013	5
5/30/2013	20	5046.565	2013	5
5/30/2013	21	4720.75	2013	5
5/30/2013	22	4314.16	2013	5
5/30/2013	23	3900.568	2013	5
5/31/2013	0	3719.768	2013	5
5/31/2013	1	3534.367	2013	5
5/31/2013	2	3378.468	2013	5
5/31/2013	3	3353.867	2013	5
5/31/2013	4	3517.768	2013	5
5/31/2013	5	3668.169	2013	5
5/31/2013	6	3993.768	2013	5
5/31/2013	7	4205.069	2013	5
5/31/2013	8	4455.468	2013	5
5/31/2013	9	4681.568	2013	5
5/31/2013	10	4831.169	2013	5
5/31/2013	11	4958.368	2013	5
5/31/2013	12	4960.668	2013	5
5/31/2013	13	5036.668	2013	5
5/31/2013	14	5004.669	2013	5
5/31/2013	15	4834.856	2013	5
5/31/2013	16	4768.055	2013	5
5/31/2013	17	4711.369	2013	5
5/31/2013	18	4577.068	2013	5
5/31/2013	19	4517.469	2013	5
5/31/2013	20	4509.567	2013	5
5/31/2013	21	4328.867	2013	5

Day	Hr	Total	Year	Month
5/31/2013	22	4016.86	2013	5
5/31/2013	23	3738.358	2013	5
6/1/2013	0	3463.267	2013	6
6/1/2013	1	3265.368	2013	6
6/1/2013	2	3127.568	2013	6
6/1/2013	3	3114.667	2013	6
6/1/2013	4	3103.568	2013	6
6/1/2013	5	3158.569	2013	6
6/1/2013	6	3263.767	2013	6
6/1/2013	7	3405.769	2013	6
6/1/2013	8	3563.469	2013	6
6/1/2013	9	3801.459	2013	6
6/1/2013	10	3985.957	2013	6
6/1/2013	11	4007.068	2013	6
6/1/2013	12	4119.192	2013	6
6/1/2013	13	4138.968	2013	6
6/1/2013	14	4293.569	2013	6
6/1/2013	15	4344.168	2013	6
6/1/2013	16	4302.468	2013	6
6/1/2013	17	4218.569	2013	6
6/1/2013	18	4051.368	2013	6
6/1/2013	19	3978.261	2013	6
6/1/2013	20	4004.357	2013	6
6/1/2013	21	3835.967	2013	6
6/1/2013	22	3525.067	2013	6
6/1/2013	23	3302.269	2013	6
6/2/2013	0	3056.068	2013	6
6/2/2013	1	2922.069	2013	6
6/2/2013	2	2880.968	2013	6
6/2/2013	3	2814.052	2013	6
6/2/2013	4	2794.167	2013	6
6/2/2013	5	2748.969	2013	6
6/2/2013	6	2853.47	2013	6
6/2/2013	7	3089.169	2013	6
6/2/2013	8	3281.969	2013	6
6/2/2013	9	3489.568	2013	6
6/2/2013	10	3633.069	2013	6
6/2/2013	11	3779.269	2013	6
6/2/2013	12	3873.868	2013	6
6/2/2013	13	3931.869	2013	6
6/2/2013	14	4027.269	2013	6
6/2/2013	15	4116.468	2013	6
6/2/2013	16	4229.168	2013	6
6/2/2013	17	4156.769	2013	6
6/2/2013	18	4038.069	2013	6
6/2/2013	19	3935.068	2013	6
6/2/2013	20	3908.068	2013	6
6/2/2013	21	3776.265	2013	6
6/2/2013	22	3470.164	2013	6
6/2/2013	23	3180.952	2013	6
6/3/2013	0	3018.964	2013	6
6/3/2013	1	2933.268	2013	6
6/3/2013	2	2893.366	2013	6
6/3/2013	3	2928.069	2013	6
6/3/2013	4	2977.568	2013	6
6/3/2013	5	3226.366	2013	6
6/3/2013	6	3461.468	2013	6
6/3/2013	7	3716.268	2013	6
6/3/2013	8	3900.599	2013	6
6/3/2013	9	4065.069	2013	6
6/3/2013	10	4171.768	2013	6
6/3/2013	11	4278.467	2013	6
6/3/2013	12	4378.965	2013	6
6/3/2013	13	4409.452	2013	6

Day	Hr	Total	Year	Month
6/3/2013	14	4447.266	2013	6
6/3/2013	15	4440.169	2013	6
6/3/2013	16	4452.669	2013	6
6/3/2013	17	4416.168	2013	6
6/3/2013	18	4308.069	2013	6
6/3/2013	19	4193.768	2013	6
6/3/2013	20	4157.166	2013	6
6/3/2013	21	3943.767	2013	6
6/3/2013	22	3610.166	2013	6
6/3/2013	23	3326.764	2013	6
6/4/2013	0	3129.365	2013	6
6/4/2013	1	3014.965	2013	6
6/4/2013	2	2891.95	2013	6
6/4/2013	3	2887.559	2013	6
6/4/2013	4	3027.964	2013	6
6/4/2013	5	3214.666	2013	6
6/4/2013	6	3476.165	2013	6
6/4/2013	7	3664.169	2013	6
6/4/2013	8	3853.269	2013	6
6/4/2013	9	4039.369	2013	6
6/4/2013	10	4192.869	2013	6
6/4/2013	11	4335.669	2013	6
6/4/2013	12	4458.269	2013	6
6/4/2013	13	4513.068	2013	6
6/4/2013	14	4574.369	2013	6
6/4/2013	15	4650.469	2013	6
6/4/2013	16	4686.969	2013	6
6/4/2013	17	4652.669	2013	6
6/4/2013	18	4508.968	2013	6
6/4/2013	19	4386.568	2013	6
6/4/2013	20	4369.251	2013	6
6/4/2013	21	4130.764	2013	6
6/4/2013	22	3774.067	2013	6
6/4/2013	23	3449.768	2013	6
6/5/2013	0	3203.068	2013	6
6/5/2013	1	3075.067	2013	6
6/5/2013	2	3019.769	2013	6
6/5/2013	3	2905.069	2013	6
6/5/2013	4	3082.467	2013	6
6/5/2013	5	3276.468	2013	6
6/5/2013	6	3510.87	2013	6
6/5/2013	7	3758.152	2013	6
6/5/2013	8	3989.869	2013	6
6/5/2013	9	4243.053	2013	6
6/5/2013	10	4500.359	2013	6
6/5/2013	11	4718.069	2013	6
6/5/2013	12	4933.268	2013	6
6/5/2013	13	5038.972	2013	6
6/5/2013	14	5102.376	2013	6
6/5/2013	15	5099.075	2013	6
6/5/2013	16	5037.876	2013	6
6/5/2013	17	4945.975	2013	6
6/5/2013	18	4789.974	2013	6
6/5/2013	19	4676.169	2013	6
6/5/2013	20	4634.267	2013	6
6/5/2013	21	4411.667	2013	6
6/5/2013	22	4074.067	2013	6
6/5/2013	23	3746.167	2013	6
6/6/2013	0	3555.559	2013	6
6/6/2013	1	3340.151	2013	6
6/6/2013	2	3243.966	2013	6
6/6/2013	3	3217.068	2013	6
6/6/2013	4	3355.161	2013	6
6/6/2013	5	3541.552	2013	6

Day	Hr	Total	Year	Month
6/6/2013	6	3779.268	2013	6
6/6/2013	7	4016.568	2013	6
6/6/2013	8	4171.667	2013	6
6/6/2013	9	4228.969	2013	6
6/6/2013	10	4398.868	2013	6
6/6/2013	11	4559.669	2013	6
6/6/2013	12	4633.869	2013	6
6/6/2013	13	4728.868	2013	6
6/6/2013	14	4798.669	2013	6
6/6/2013	15	4809.169	2013	6
6/6/2013	16	4828.268	2013	6
6/6/2013	17	4722.969	2013	6
6/6/2013	18	4636.168	2013	6
6/6/2013	19	4549.369	2013	6
6/6/2013	20	4523.468	2013	6
6/6/2013	21	4293.267	2013	6
6/6/2013	22	3950.367	2013	6
6/6/2013	23	3584.552	2013	6
6/7/2013	0	3409.063	2013	6
6/7/2013	1	3217.268	2013	6
6/7/2013	2	3130.169	2013	6
6/7/2013	3	3053.669	2013	6
6/7/2013	4	3188.869	2013	6
6/7/2013	5	3373.77	2013	6
6/7/2013	6	3622.07	2013	6
6/7/2013	7	3761.669	2013	6
6/7/2013	8	3943.669	2013	6
6/7/2013	9	4057.369	2013	6
6/7/2013	10	4211.568	2013	6
6/7/2013	11	4369.369	2013	6
6/7/2013	12	4470.369	2013	6
6/7/2013	13	4610.529	2013	6
6/7/2013	14	4675.171	2013	6
6/7/2013	15	4748.874	2013	6
6/7/2013	16	4688.074	2013	6
6/7/2013	17	4531.769	2013	6
6/7/2013	18	4364.968	2013	6
6/7/2013	19	4260.369	2013	6
6/7/2013	20	4219.868	2013	6
6/7/2013	21	4027.857	2013	6
6/7/2013	22	3761.557	2013	6
6/7/2013	23	3437.468	2013	6
6/8/2013	0	3250.268	2013	6
6/8/2013	1	3095.281	2013	6
6/8/2013	2	2919.269	2013	6
6/8/2013	3	2863.867	2013	6
6/8/2013	4	2870.867	2013	6
6/8/2013	5	2898.47	2013	6
6/8/2013	6	2981.07	2013	6
6/8/2013	7	3139.869	2013	6
6/8/2013	8	3389.269	2013	6
6/8/2013	9	3612.557	2013	6
6/8/2013	10	3833.161	2013	6
6/8/2013	11	4001.469	2013	6
6/8/2013	12	4137.968	2013	6
6/8/2013	13	4203.069	2013	6
6/8/2013	14	4277.469	2013	6
6/8/2013	15	4397.569	2013	6
6/8/2013	16	4422.368	2013	6
6/8/2013	17	4436.969	2013	6
6/8/2013	18	4313.169	2013	6
6/8/2013	19	4119.969	2013	6
6/8/2013	20	4094.567	2013	6
6/8/2013	21	3866.268	2013	6

Day	Hr	Total	Year	Month
6/8/2013	22	3556.967	2013	6
6/8/2013	23	3245.668	2013	6
6/9/2013	0	3041.668	2013	6
6/9/2013	1	2881.767	2013	6
6/9/2013	2	2781.051	2013	6
6/9/2013	3	2719.564	2013	6
6/9/2013	4	2648.27	2013	6
6/9/2013	5	2673.369	2013	6
6/9/2013	6	2696.87	2013	6
6/9/2013	7	3028.869	2013	6
6/9/2013	8	3298.769	2013	6
6/9/2013	9	3586.668	2013	6
6/9/2013	10	3759.669	2013	6
6/9/2013	11	3925.268	2013	6
6/9/2013	12	4052.869	2013	6
6/9/2013	13	4025.069	2013	6
6/9/2013	14	3941.168	2013	6
6/9/2013	15	3983.868	2013	6
6/9/2013	16	4042.269	2013	6
6/9/2013	17	4014.368	2013	6
6/9/2013	18	3950.369	2013	6
6/9/2013	19	3917.668	2013	6
6/9/2013	20	3935.452	2013	6
6/9/2013	21	3752.059	2013	6
6/9/2013	22	3499.368	2013	6
6/9/2013	23	3232.168	2013	6
6/10/2013	0	3088.068	2013	6
6/10/2013	1	2985.968	2013	6
6/10/2013	2	2989.468	2013	6
6/10/2013	3	2985.956	2013	6
6/10/2013	4	3155.261	2013	6
6/10/2013	5	3407.469	2013	6
6/10/2013	6	3621.469	2013	6
6/10/2013	7	3830.569	2013	6
6/10/2013	8	4061.469	2013	6
6/10/2013	9	4155.868	2013	6
6/10/2013	10	4327.468	2013	6
6/10/2013	11	4478.169	2013	6
6/10/2013	12	4657.569	2013	6
6/10/2013	13	4647.568	2013	6
6/10/2013	14	4643.069	2013	6
6/10/2013	15	4644.668	2013	6
6/10/2013	16	4613.269	2013	6
6/10/2013	17	4580.968	2013	6
6/10/2013	18	4469.769	2013	6
6/10/2013	19	4410.018	2013	6
6/10/2013	20	4344.968	2013	6
6/10/2013	21	4156.861	2013	6
6/10/2013	22	3811.051	2013	6
6/10/2013	23	3481.468	2013	6
6/11/2013	0	3231.866	2013	6
6/11/2013	1	3123.967	2013	6
6/11/2013	2	3013.767	2013	6
6/11/2013	3	2979.469	2013	6
6/11/2013	4	3069.669	2013	6
6/11/2013	5	3275.968	2013	6
6/11/2013	6	3547.869	2013	6
6/11/2013	7	3852.369	2013	6
6/11/2013	8	4166.569	2013	6
6/11/2013	9	4427.569	2013	6
6/11/2013	10	4657.069	2013	6
6/11/2013	11	4990.974	2013	6
6/11/2013	12	5118.376	2013	6
6/11/2013	13	5233.275	2013	6

Day	Hr	Total	Year	Month
6/11/2013	14	5337.176	2013	6
6/11/2013	15	5457.445	2013	6
6/11/2013	16	5489.776	2013	6
6/11/2013	17	5372.574	2013	6
6/11/2013	18	5180.673	2013	6
6/11/2013	19	5070.768	2013	6
6/11/2013	20	4996.968	2013	6
6/11/2013	21	4789.967	2013	6
6/11/2013	22	4388.556	2013	6
6/11/2013	23	4021.754	2013	6
6/12/2013	0	3752.768	2013	6
6/12/2013	1	3635.968	2013	6
6/12/2013	2	3526.768	2013	6
6/12/2013	3	3401.168	2013	6
6/12/2013	4	3573.666	2013	6
6/12/2013	5	3762.652	2013	6
6/12/2013	6	4095.665	2013	6
6/12/2013	7	4463.769	2013	6
6/12/2013	8	4895.469	2013	6
6/12/2013	9	5307.468	2013	6
6/12/2013	10	5534.471	2013	6
6/12/2013	11	5787.275	2013	6
6/12/2013	12	5980.375	2013	6
6/12/2013	13	6148.875	2013	6
6/12/2013	14	6262.676	2013	6
6/12/2013	15	6287.575	2013	6
6/12/2013	16	6233.076	2013	6
6/12/2013	17	6121.975	2013	6
6/12/2013	18	5937.175	2013	6
6/12/2013	19	5793.276	2013	6
6/12/2013	20	5678.074	2013	6
6/12/2013	21	5426.071	2013	6
6/12/2013	22	5066.774	2013	6
6/12/2013	23	4684.268	2013	6
6/13/2013	0	4477.067	2013	6
6/13/2013	1	4269.467	2013	6
6/13/2013	2	4191.467	2013	6
6/13/2013	3	4079.068	2013	6
6/13/2013	4	4241.467	2013	6
6/13/2013	5	4405.768	2013	6
6/13/2013	6	4610.968	2013	6
6/13/2013	7	4897.568	2013	6
6/13/2013	8	5095.069	2013	6
6/13/2013	9	5174.172	2013	6
6/13/2013	10	5186.075	2013	6
6/13/2013	11	5196.274	2013	6
6/13/2013	12	5182.475	2013	6
6/13/2013	13	5089.369	2013	6
6/13/2013	14	5140.576	2013	6
6/13/2013	15	5097.474	2013	6
6/13/2013	16	5059.374	2013	6
6/13/2013	17	4960.875	2013	6
6/13/2013	18	4794.469	2013	6
6/13/2013	19	4602.768	2013	6
6/13/2013	20	4529.768	2013	6
6/13/2013	21	4314.767	2013	6
6/13/2013	22	3894.468	2013	6
6/13/2013	23	3628.867	2013	6
6/14/2013	0	3338.668	2013	6
6/14/2013	1	3168.163	2013	6
6/14/2013	2	3045.052	2013	6
6/14/2013	3	2952.253	2013	6
6/14/2013	4	3097.667	2013	6
6/14/2013	5	3230.968	2013	6

Day	Hr	Total	Year	Month
6/14/2013	6	3491.169	2013	6
6/14/2013	7	3729.769	2013	6
6/14/2013	8	3981.769	2013	6
6/14/2013	9	4179.468	2013	6
6/14/2013	10	4374.369	2013	6
6/14/2013	11	4548.869	2013	6
6/14/2013	12	4734.569	2013	6
6/14/2013	13	4849.275	2013	6
6/14/2013	14	4969.475	2013	6
6/14/2013	15	5016.575	2013	6
6/14/2013	16	5023.076	2013	6
6/14/2013	17	4941.475	2013	6
6/14/2013	18	4762.275	2013	6
6/14/2013	19	4557.469	2013	6
6/14/2013	20	4514.868	2013	6
6/14/2013	21	4245.167	2013	6
6/14/2013	22	3900.768	2013	6
6/14/2013	23	3513.668	2013	6
6/15/2013	0	3269.7	2013	6
6/15/2013	1	3125.36	2013	6
6/15/2013	2	3005.465	2013	6
6/15/2013	3	2892.767	2013	6
6/15/2013	4	2882.731	2013	6
6/15/2013	5	2880.667	2013	6
6/15/2013	6	2955.67	2013	6
6/15/2013	7	3212.568	2013	6
6/15/2013	8	3547.569	2013	6
6/15/2013	9	3820.669	2013	6
6/15/2013	10	4101.569	2013	6
6/15/2013	11	4324.57	2013	6
6/15/2013	12	4467.076	2013	6
6/15/2013	13	4639.575	2013	6
6/15/2013	14	4767.776	2013	6
6/15/2013	15	4859.375	2013	6
6/15/2013	16	4935.376	2013	6
6/15/2013	17	4926.875	2013	6
6/15/2013	18	4806.175	2013	6
6/15/2013	19	4561.675	2013	6
6/15/2013	20	4451.268	2013	6
6/15/2013	21	4195.967	2013	6
6/15/2013	22	3854.768	2013	6
6/15/2013	23	3547.368	2013	6
6/16/2013	0	3278.063	2013	6
6/16/2013	1	3150.152	2013	6
6/16/2013	2	3033.066	2013	6
6/16/2013	3	2972.868	2013	6
6/16/2013	4	2973.568	2013	6
6/16/2013	5	2967.568	2013	6
6/16/2013	6	3007.469	2013	6
6/16/2013	7	3235.768	2013	6
6/16/2013	8	3480.494	2013	6
6/16/2013	9	3686.555	2013	6
6/16/2013	10	3952.369	2013	6
6/16/2013	11	4222.969	2013	6
6/16/2013	12	4403.874	2013	6
6/16/2013	13	4472.873	2013	6
6/16/2013	14	4505.176	2013	6
6/16/2013	15	4518.573	2013	6
6/16/2013	16	4421.069	2013	6
6/16/2013	17	4209.268	2013	6
6/16/2013	18	4075.369	2013	6
6/16/2013	19	4016.159	2013	6
6/16/2013	20	4002.455	2013	6
6/16/2013	21	3866.667	2013	6

Day	Hr	Total	Year	Month
6/16/2013	22	3606.268	2013	6
6/16/2013	23	3317.268	2013	6
6/17/2013	0	3197.368	2013	6
6/17/2013	1	3080.268	2013	6
6/17/2013	2	3034.069	2013	6
6/17/2013	3	3073.055	2013	6
6/17/2013	4	3212.367	2013	6
6/17/2013	5	3478.669	2013	6
6/17/2013	6	3696.868	2013	6
6/17/2013	7	4044.557	2013	6
6/17/2013	8	4353.164	2013	6
6/17/2013	9	4719.369	2013	6
6/17/2013	10	5003.571	2013	6
6/17/2013	11	5273.075	2013	6
6/17/2013	12	5523.375	2013	6
6/17/2013	13	5643.176	2013	6
6/17/2013	14	5714.775	2013	6
6/17/2013	15	5643.075	2013	6
6/17/2013	16	5342.174	2013	6
6/17/2013	17	5030.968	2013	6
6/17/2013	18	4786.268	2013	6
6/17/2013	19	4698.867	2013	6
6/17/2013	20	4533.667	2013	6
6/17/2013	21	4284.266	2013	6
6/17/2013	22	3895.151	2013	6
6/17/2013	23	3665.361	2013	6
6/18/2013	0	3485.364	2013	6
6/18/2013	1	3333.767	2013	6
6/18/2013	2	3132.867	2013	6
6/18/2013	3	3172.267	2013	6
6/18/2013	4	3253.766	2013	6
6/18/2013	5	3508.467	2013	6
6/18/2013	6	3732.667	2013	6
6/18/2013	7	3907.857	2013	6
6/18/2013	8	4144.761	2013	6
6/18/2013	9	4362.367	2013	6
6/18/2013	10	4552.069	2013	6
6/18/2013	11	4767.268	2013	6
6/18/2013	12	4990.575	2013	6
6/18/2013	13	5106.775	2013	6
6/18/2013	14	5251.375	2013	6
6/18/2013	15	5325.775	2013	6
6/18/2013	16	5374.475	2013	6
6/18/2013	17	5339.076	2013	6
6/18/2013	18	5170.974	2013	6
6/18/2013	19	4927.167	2013	6
6/18/2013	20	4687.268	2013	6
6/18/2013	21	4352.666	2013	6
6/18/2013	22	3968.767	2013	6
6/18/2013	23	3600.265	2013	6
6/19/2013	0	3327.064	2013	6
6/19/2013	1	3218.463	2013	6
6/19/2013	2	3110.652	2013	6
6/19/2013	3	3011.161	2013	6
6/19/2013	4	3163.768	2013	6
6/19/2013	5	3357.768	2013	6
6/19/2013	6	3621.369	2013	6
6/19/2013	7	3870.867	2013	6
6/19/2013	8	4122.467	2013	6
6/19/2013	9	4448.367	2013	6
6/19/2013	10	4681.968	2013	6
6/19/2013	11	4896.368	2013	6
6/19/2013	12	5091.668	2013	6
6/19/2013	13	5198.971	2013	6

Day	Hr	Total	Year	Month
6/19/2013	14	5303.675	2013	6
6/19/2013	15	5336.874	2013	6
6/19/2013	16	5369.775	2013	6
6/19/2013	17	5345.475	2013	6
6/19/2013	18	5163.773	2013	6
6/19/2013	19	4994.669	2013	6
6/19/2013	20	4849.466	2013	6
6/19/2013	21	4557.375	2013	6
6/19/2013	22	4163.666	2013	6
6/19/2013	23	3757.166	2013	6
6/20/2013	0	3524.699	2013	6
6/20/2013	1	3293.855	2013	6
6/20/2013	2	3179.166	2013	6
6/20/2013	3	3141.067	2013	6
6/20/2013	4	3209.163	2013	6
6/20/2013	5	3399.067	2013	6
6/20/2013	6	3706.867	2013	6
6/20/2013	7	3996.167	2013	6
6/20/2013	8	4301.267	2013	6
6/20/2013	9	4601.967	2013	6
6/20/2013	10	4886.868	2013	6
6/20/2013	11	5122.075	2013	6
6/20/2013	12	5324.275	2013	6
6/20/2013	13	5455.774	2013	6
6/20/2013	14	5560.875	2013	6
6/20/2013	15	5556.775	2013	6
6/20/2013	16	5591.375	2013	6
6/20/2013	17	5498.873	2013	6
6/20/2013	18	5326.776	2013	6
6/20/2013	19	5154.272	2013	6
6/20/2013	20	5049.672	2013	6
6/20/2013	21	4774.267	2013	6
6/20/2013	22	4320.266	2013	6
6/20/2013	23	3943.367	2013	6
6/21/2013	0	3630.466	2013	6
6/21/2013	1	3471.267	2013	6
6/21/2013	2	3307.358	2013	6
6/21/2013	3	3231.346	2013	6
6/21/2013	4	3340.767	2013	6
6/21/2013	5	3505.565	2013	6
6/21/2013	6	3764.866	2013	6
6/21/2013	7	4076.567	2013	6
6/21/2013	8	4380.267	2013	6
6/21/2013	9	4754.568	2013	6
6/21/2013	10	5026.772	2013	6
6/21/2013	11	5296.975	2013	6
6/21/2013	12	5532.675	2013	6
6/21/2013	13	5660.375	2013	6
6/21/2013	14	5720.075	2013	6
6/21/2013	15	5731.175	2013	6
6/21/2013	16	5691.375	2013	6
6/21/2013	17	5578.675	2013	6
6/21/2013	18	5385.075	2013	6
6/21/2013	19	5164.873	2013	6
6/21/2013	20	5049.273	2013	6
6/21/2013	21	4749.18	2013	6
6/21/2013	22	4339.267	2013	6
6/21/2013	23	3994.866	2013	6
6/22/2013	0	3754.267	2013	6
6/22/2013	1	3503.366	2013	6
6/22/2013	2	3351.191	2013	6
6/22/2013	3	3246.955	2013	6
6/22/2013	4	3204.366	2013	6
6/22/2013	5	3203.768	2013	6

Day	Hr	Total	Year	Month
6/22/2013	6	3305.767	2013	6
6/22/2013	7	3640.567	2013	6
6/22/2013	8	4000.368	2013	6
6/22/2013	9	4387.469	2013	6
6/22/2013	10	4730.574	2013	6
6/22/2013	11	4947.775	2013	6
6/22/2013	12	5098.775	2013	6
6/22/2013	13	5267.374	2013	6
6/22/2013	14	5280.475	2013	6
6/22/2013	15	5342.075	2013	6
6/22/2013	16	5346.875	2013	6
6/22/2013	17	5251.575	2013	6
6/22/2013	18	5086.575	2013	6
6/22/2013	19	4820.47	2013	6
6/22/2013	20	4676.567	2013	6
6/22/2013	21	4380.266	2013	6
6/22/2013	22	4025.367	2013	6
6/22/2013	23	3677.566	2013	6
6/23/2013	0	3393.466	2013	6
6/23/2013	1	3198.751	2013	6
6/23/2013	2	3034.458	2013	6
6/23/2013	3	2969.166	2013	6
6/23/2013	4	2929.567	2013	6
6/23/2013	5	2873.367	2013	6
6/23/2013	6	2981.465	2013	6
6/23/2013	7	3318.455	2013	6
6/23/2013	8	3683.468	2013	6
6/23/2013	9	4069.269	2013	6
6/23/2013	10	4389.275	2013	6
6/23/2013	11	4650.374	2013	6
6/23/2013	12	4714.173	2013	6
6/23/2013	13	4793.975	2013	6
6/23/2013	14	4836.375	2013	6
6/23/2013	15	4913.875	2013	6
6/23/2013	16	4942.374	2013	6
6/23/2013	17	4856.875	2013	6
6/23/2013	18	4776.673	2013	6
6/23/2013	19	4598.073	2013	6
6/23/2013	20	4533.567	2013	6
6/23/2013	21	4306.666	2013	6
6/23/2013	22	3980.367	2013	6
6/23/2013	23	3635.966	2013	6
6/24/2013	0	3415.552	2013	6
6/24/2013	1	3256.057	2013	6
6/24/2013	2	3183.066	2013	6
6/24/2013	3	3168.567	2013	6
6/24/2013	4	3309.166	2013	6
6/24/2013	5	3523.167	2013	6
6/24/2013	6	3809.764	2013	6
6/24/2013	7	4108.253	2013	6
6/24/2013	8	4333.667	2013	6
6/24/2013	9	4579.067	2013	6
6/24/2013	10	4797.768	2013	6
6/24/2013	11	4926.567	2013	6
6/24/2013	12	5022.767	2013	6
6/24/2013	13	5013.967	2013	6
6/24/2013	14	4952.167	2013	6
6/24/2013	15	4896.667	2013	6
6/24/2013	16	4822.668	2013	6
6/24/2013	17	4777.167	2013	6
6/24/2013	18	4666.467	2013	6
6/24/2013	19	4569.167	2013	6
6/24/2013	20	4542.467	2013	6
6/24/2013	21	4300.666	2013	6

Day	Hr	Total	Year	Month
6/24/2013	22	3979.358	2013	6
6/24/2013	23	3680.951	2013	6
6/25/2013	0	3463.866	2013	6
6/25/2013	1	3298.266	2013	6
6/25/2013	2	3199.367	2013	6
6/25/2013	3	3143.367	2013	6
6/25/2013	4	3263.466	2013	6
6/25/2013	5	3482.458	2013	6
6/25/2013	6	3739.056	2013	6
6/25/2013	7	4061.182	2013	6
6/25/2013	8	4432.467	2013	6
6/25/2013	9	4821.268	2013	6
6/25/2013	10	5196.973	2013	6
6/25/2013	11	5459.976	2013	6
6/25/2013	12	5677.575	2013	6
6/25/2013	13	5853.075	2013	6
6/25/2013	14	5953.874	2013	6
6/25/2013	15	5977.075	2013	6
6/25/2013	16	5979.875	2013	6
6/25/2013	17	5861.175	2013	6
6/25/2013	18	5673.073	2013	6
6/25/2013	19	5529.075	2013	6
6/25/2013	20	5411.973	2013	6
6/25/2013	21	5137.368	2013	6
6/25/2013	22	4732.066	2013	6
6/25/2013	23	4367.567	2013	6
6/26/2013	0	4090.266	2013	6
6/26/2013	1	3895.867	2013	6
6/26/2013	2	3751.066	2013	6
6/26/2013	3	3603.066	2013	6
6/26/2013	4	3643.467	2013	6
6/26/2013	5	3806.954	2013	6
6/26/2013	6	3985.054	2013	6
6/26/2013	7	4188.867	2013	6
6/26/2013	8	4450.367	2013	6
6/26/2013	9	4739.267	2013	6
6/26/2013	10	5022.768	2013	6
6/26/2013	11	5316.667	2013	6
6/26/2013	12	5555.671	2013	6
6/26/2013	13	5656.375	2013	6
6/26/2013	14	5697.574	2013	6
6/26/2013	15	5623.074	2013	6
6/26/2013	16	5318.368	2013	6
6/26/2013	17	5041.767	2013	6
6/26/2013	18	4797.166	2013	6
6/26/2013	19	4647.654	2013	6
6/26/2013	20	4547.108	2013	6
6/26/2013	21	4275.253	2013	6
6/26/2013	22	3940.966	2013	6
6/26/2013	23	3685.967	2013	6
6/27/2013	0	3462.265	2013	6
6/27/2013	1	3342.367	2013	6
6/27/2013	2	3258.566	2013	6
6/27/2013	3	3207.566	2013	6
6/27/2013	4	3324.366	2013	6
6/27/2013	5	3572.161	2013	6
6/27/2013	6	3813.753	2013	6
6/27/2013	7	4026.467	2013	6
6/27/2013	8	4211.967	2013	6
6/27/2013	9	4446.167	2013	6
6/27/2013	10	4668.467	2013	6
6/27/2013	11	4960.367	2013	6
6/27/2013	12	5167.971	2013	6
6/27/2013	13	5365.475	2013	6

Day	Hr	Total	Year	Month
6/27/2013	14	5532.275	2013	6
6/27/2013	15	5619.676	2013	6
6/27/2013	16	5655.775	2013	6
6/27/2013	17	5553.833	2013	6
6/27/2013	18	5432.375	2013	6
6/27/2013	19	5322.973	2013	6
6/27/2013	20	5171.371	2013	6
6/27/2013	21	4902.097	2013	6
6/27/2013	22	4542.566	2013	6
6/27/2013	23	4124.366	2013	6
6/28/2013	0	3880.766	2013	6
6/28/2013	1	3732.067	2013	6
6/28/2013	2	3560.866	2013	6
6/28/2013	3	3519.066	2013	6
6/28/2013	4	3631.95	2013	6
6/28/2013	5	3728.367	2013	6
6/28/2013	6	4015.367	2013	6
6/28/2013	7	4348.067	2013	6
6/28/2013	8	4625.468	2013	6
6/28/2013	9	4968.067	2013	6
6/28/2013	10	5169.967	2013	6
6/28/2013	11	5360.874	2013	6
6/28/2013	12	5456.174	2013	6
6/28/2013	13	5502.076	2013	6
6/28/2013	14	5545.568	2013	6
6/28/2013	15	5522.376	2013	6
6/28/2013	16	5518.576	2013	6
6/28/2013	17	5394.374	2013	6
6/28/2013	18	5194.675	2013	6
6/28/2013	19	4963.575	2013	6
6/28/2013	20	4784.269	2013	6
6/28/2013	21	4534.866	2013	6
6/28/2013	22	4185.066	2013	6
6/28/2013	23	3808.867	2013	6
6/29/2013	0	3569.466	2013	6
6/29/2013	1	3365.366	2013	6
6/29/2013	2	3217.667	2013	6
6/29/2013	3	3084.266	2013	6
6/29/2013	4	3128.151	2013	6
6/29/2013	5	3034.06	2013	6
6/29/2013	6	3134.767	2013	6
6/29/2013	7	3407.167	2013	6
6/29/2013	8	3681.968	2013	6
6/29/2013	9	4062.367	2013	6
6/29/2013	10	4272.171	2013	6
6/29/2013	11	4354.774	2013	6
6/29/2013	12	4412.071	2013	6
6/29/2013	13	4542.974	2013	6
6/29/2013	14	4658.272	2013	6
6/29/2013	15	4627.167	2013	6
6/29/2013	16	4709.57	2013	6
6/29/2013	17	4651.073	2013	6
6/29/2013	18	4392.167	2013	6
6/29/2013	19	4209.367	2013	6
6/29/2013	20	4061.967	2013	6
6/29/2013	21	3777.356	2013	6
6/29/2013	22	3494.446	2013	6
6/29/2013	23	3237.666	2013	6
6/30/2013	0	3076.262	2013	6
6/30/2013	1	2905.862	2013	6
6/30/2013	2	2790.868	2013	6
6/30/2013	3	2752.364	2013	6
6/30/2013	4	2803.763	2013	6
6/30/2013	5	2805.866	2013	6

Day	Hr	Total	Year	Month
6/30/2013	6	2852.353	2013	6
6/30/2013	7	2995.164	2013	6
6/30/2013	8	3229.768	2013	6
6/30/2013	9	3433.967	2013	6
6/30/2013	10	3760.267	2013	6
6/30/2013	11	3903.568	2013	6
6/30/2013	12	4158.767	2013	6
6/30/2013	13	4255.368	2013	6
6/30/2013	14	4381.369	2013	6
6/30/2013	15	4541.976	2013	6
6/30/2013	16	4543.773	2013	6
6/30/2013	17	4523.868	2013	6
6/30/2013	18	4406.267	2013	6
6/30/2013	19	4186.168	2013	6
6/30/2013	20	4138.766	2013	6
6/30/2013	21	3924.761	2013	6
6/30/2013	22	3642.45	2013	6
6/30/2013	23	3347.966	2013	6
7/1/2013	0	3139.367	2013	7
7/1/2013	1	3001.267	2013	7
7/1/2013	2	2993.866	2013	7
7/1/2013	3	2971.967	2013	7
7/1/2013	4	3175.263	2013	7
7/1/2013	5	3343.955	2013	7
7/1/2013	6	3517.368	2013	7
7/1/2013	7	3729.666	2013	7
7/1/2013	8	3907.868	2013	7
7/1/2013	9	4100.468	2013	7
7/1/2013	10	4253.368	2013	7
7/1/2013	11	4417.967	2013	7
7/1/2013	12	4636.067	2013	7
7/1/2013	13	4681.867	2013	7
7/1/2013	14	4817.068	2013	7
7/1/2013	15	4804.874	2013	7
7/1/2013	16	4641.567	2013	7
7/1/2013	17	4460.167	2013	7
7/1/2013	18	4284.767	2013	7
7/1/2013	19	4101.56	2013	7
7/1/2013	20	4001.851	2013	7
7/1/2013	21	3788.667	2013	7
7/1/2013	22	3556.463	2013	7
7/1/2013	23	3348.863	2013	7
7/2/2013	0	3120.462	2013	7
7/2/2013	1	2975.164	2013	7
7/2/2013	2	2918.768	2013	7
7/2/2013	3	2927.968	2013	7
7/2/2013	4	2969.267	2013	7
7/2/2013	5	3169.365	2013	7
7/2/2013	6	3356.053	2013	7
7/2/2013	7	3545.754	2013	7
7/2/2013	8	3783.768	2013	7
7/2/2013	9	4017.359	2013	7
7/2/2013	10	4192.867	2013	7
7/2/2013	11	4471.453	2013	7
7/2/2013	12	4642.956	2013	7
7/2/2013	13	4702.455	2013	7
7/2/2013	14	4833.656	2013	7
7/2/2013	15	4879.857	2013	7
7/2/2013	16	4926.957	2013	7
7/2/2013	17	4874.056	2013	7
7/2/2013	18	4739.256	2013	7
7/2/2013	19	4656.086	2013	7
7/2/2013	20	4527.955	2013	7
7/2/2013	21	4299.954	2013	7

Day	Hr	Total	Year	Month
7/2/2013	22	3947.351	2013	7
7/2/2013	23	3644.048	2013	7
7/3/2013	0	3361.748	2013	7
7/3/2013	1	3223.748	2013	7
7/3/2013	2	3134.046	2013	7
7/3/2013	3	3106.948	2013	7
7/3/2013	4	3203.944	2013	7
7/3/2013	5	3361.55	2013	7
7/3/2013	6	3526.148	2013	7
7/3/2013	7	3726.749	2013	7
7/3/2013	8	4019.249	2013	7
7/3/2013	9	4160.749	2013	7
7/3/2013	10	4427.851	2013	7
7/3/2013	11	4686.155	2013	7
7/3/2013	12	4794.756	2013	7
7/3/2013	13	4856.373	2013	7
7/3/2013	14	4834.657	2013	7
7/3/2013	15	4789.654	2013	7
7/3/2013	16	4703.052	2013	7
7/3/2013	17	4542.149	2013	7
7/3/2013	18	4389.348	2013	7
7/3/2013	19	4301.749	2013	7
7/3/2013	20	4291.448	2013	7
7/3/2013	21	4069.948	2013	7
7/3/2013	22	3805.648	2013	7
7/3/2013	23	3558.148	2013	7
7/4/2013	0	3331.548	2013	7
7/4/2013	1	3145.948	2013	7
7/4/2013	2	3035.148	2013	7
7/4/2013	3	2961.648	2013	7
7/4/2013	4	2966.948	2013	7
7/4/2013	5	2977.948	2013	7
7/4/2013	6	2991.249	2013	7
7/4/2013	7	3083.948	2013	7
7/4/2013	8	3221.55	2013	7
7/4/2013	9	3353.548	2013	7
7/4/2013	10	3523.548	2013	7
7/4/2013	11	3583.75	2013	7
7/4/2013	12	3622.657	2013	7
7/4/2013	13	3593.067	2013	7
7/4/2013	14	3590.267	2013	7
7/4/2013	15	3596.468	2013	7
7/4/2013	16	3557.767	2013	7
7/4/2013	17	3500.967	2013	7
7/4/2013	18	3411.667	2013	7
7/4/2013	19	3424.768	2013	7
7/4/2013	20	3440.059	2013	7
7/4/2013	21	3323.754	2013	7
7/4/2013	22	3170.267	2013	7
7/4/2013	23	3018.967	2013	7
7/5/2013	0	2855.665	2013	7
7/5/2013	1	2756.068	2013	7
7/5/2013	2	2688.367	2013	7
7/5/2013	3	2681.068	2013	7
7/5/2013	4	2786.966	2013	7
7/5/2013	5	2930.463	2013	7
7/5/2013	6	3076.454	2013	7
7/5/2013	7	3276.455	2013	7
7/5/2013	8	3462.668	2013	7
7/5/2013	9	3690.367	2013	7
7/5/2013	10	3802.067	2013	7
7/5/2013	11	3892.867	2013	7
7/5/2013	12	3995.468	2013	7
7/5/2013	13	4075.367	2013	7

Day	Hr	Total	Year	Month
7/5/2013	14	4170.967	2013	7
7/5/2013	15	4182.468	2013	7
7/5/2013	16	4172.467	2013	7
7/5/2013	17	4088.367	2013	7
7/5/2013	18	3960.068	2013	7
7/5/2013	19	3920.667	2013	7
7/5/2013	20	3900.167	2013	7
7/5/2013	21	3775.05	2013	7
7/5/2013	22	3536.957	2013	7
7/5/2013	23	3334.367	2013	7
7/6/2013	0	3106.766	2013	7
7/6/2013	1	2999.267	2013	7
7/6/2013	2	2871.863	2013	7
7/6/2013	3	2838.852	2013	7
7/6/2013	4	2849.566	2013	7
7/6/2013	5	2861.966	2013	7
7/6/2013	6	2927.965	2013	7
7/6/2013	7	3073.569	2013	7
7/6/2013	8	3313.167	2013	7
7/6/2013	9	3444.063	2013	7
7/6/2013	10	3613.856	2013	7
7/6/2013	11	3635.167	2013	7
7/6/2013	12	3672.868	2013	7
7/6/2013	13	3720.666	2013	7
7/6/2013	14	3703.268	2013	7
7/6/2013	15	3809.167	2013	7
7/6/2013	16	3741.267	2013	7
7/6/2013	17	3668.768	2013	7
7/6/2013	18	3602.567	2013	7
7/6/2013	19	3520.667	2013	7
7/6/2013	20	3560.807	2013	7
7/6/2013	21	3522.456	2013	7
7/6/2013	22	3291.654	2013	7
7/6/2013	23	3096.267	2013	7
7/7/2013	0	2934.494	2013	7
7/7/2013	1	2825.766	2013	7
7/7/2013	2	2764.868	2013	7
7/7/2013	3	2689.265	2013	7
7/7/2013	4	2729.468	2013	7
7/7/2013	5	2730.451	2013	7
7/7/2013	6	2757.461	2013	7
7/7/2013	7	2950.667	2013	7
7/7/2013	8	3229.867	2013	7
7/7/2013	9	3458.668	2013	7
7/7/2013	10	3664.567	2013	7
7/7/2013	11	3904.868	2013	7
7/7/2013	12	4122.168	2013	7
7/7/2013	13	4385.374	2013	7
7/7/2013	14	4480.575	2013	7
7/7/2013	15	4616.475	2013	7
7/7/2013	16	4821.074	2013	7
7/7/2013	17	4801.276	2013	7
7/7/2013	18	4767.672	2013	7
7/7/2013	19	4605.37	2013	7
7/7/2013	20	4490.867	2013	7
7/7/2013	21	4241.666	2013	7
7/7/2013	22	3902.366	2013	7
7/7/2013	23	3551.564	2013	7
7/8/2013	0	3334.691	2013	7
7/8/2013	1	3199.06	2013	7
7/8/2013	2	3113.967	2013	7
7/8/2013	3	3072.067	2013	7
7/8/2013	4	3234.866	2013	7
7/8/2013	5	3440.359	2013	7