

**COMMONWEALTH OF KENTUCKY
BEFORE THE PUBLIC SERVICE COMMISSION
Case No. 2018-00157**

In the Matter of

CMN-RUS, INC.

COMPLAINANT

v.

WINDSTREAM KENTUCKY EAST, LLC

RESPONDENT

**CMN-RUS, Inc.'s and Windstream Kentucky East, LLC's
Joint Notice of Filing per 1/10/23 Order**

Please take notice that the parties, CMN-RUS, Inc. ("CMN") and Windstream Kentucky East, LLC ("Windstream East"), by counsel, herewith file in accordance with paragraphs 3 and 12 of the PSC's Order entered January 10, 2023 ("1/10/23 Order"), a revised version of:

- The Pole Attachment License Agreement between Windstream East and CMN; and
- The First Amendment to Pole Attachment License Agreement between the parties.

The revised versions leave unredacted the information that has been denied confidential treatment by the 1/10/23 Order, with only pricing terms redacted.

Respectfully submitted,

/s/ Katherine K. Yunker

Katherine K. Yunker

MCBRAYER PLLC

201 East Main Street, Suite 900

Lexington, KY 40507

kyunker@mcbayerfirm.com

Counsel for Complainant,

CMN-RUS, Inc.

/s/ Tia J. Combs (by K. Yunker w/ permission)

Tia J. Combs

FREEMAN MATHIS & GARY, LLP

2525 Harrodsburg Drive; Suite 500

Lexington, KY 40504

tcombs@fmglaw.com

Counsel for Respondent,

Windstream Kentucky East, LLC



POLE ATTACHMENT LICENSE AGREEMENT

BY AND BETWEEN

WINDSTREAM KENTUCKY EAST, LLC

AND

CMN-RUS, INC.

TABLE OF CONTENTS

		PAGE
SECTION 1	PARTIES	4
SECTION 2	SCOPE	4
SECTION 3	DEFINITIONS	4
SECTION 4	TERM AND TERMINATION OF AGREEMENT	5
SECTION 5	TERMINATION OF LICENSES	5
SECTION 6	RATES, FEES AND CHARGES	6
SECTION 7	PAYMENT, SECURITY BOND AND LIEN	6
SECTION 8	ATTACHMENT REQUEST AND LICENSE PROCESS	7
SECTION 9	AUTHORITY FOR PLACEMENT OF ATTACHMENT	8
SECTION 10	CONSTRUCTION AND MAINTENANCE	9
SECTION 11	OVERLASHING	10
SECTION 12	MODIFICATIONS, ADDITIONS, REPLACEMENTS AND REARRANGEMENTS	11
SECTION 13	EMERGENCY RESTORATION	12
SECTION 14	FAILURE TO PLACE ATTACHMENTS	13
SECTION 15	ABANDONMENT	13
SECTION 16	INSPECTIONS AND INVENTORIES	13
SECTION 17	UNAUTHORIZED ATTACHMENTS	14
SECTION 18	COMPLIANCE WITH LAW, ASSUMPTION OF RISK AND DISCLAIMER OF WARRANTIES	15
SECTION 19	LICENSEE CONTRACTOR QUALIFICATIONS	16
SECTION 20	DEFAULT	17
SECTION 21	INDEMNIFICATION AND LIMITATION OF LIABILITY	19
SECTION 22	INSURANCE	20
WIN ILEC vrs 9.23.15 (<i>Poles only</i>)		Page 2 of 33

SECTION 23	NOTICES	21
SECTION 24	CONFIDENTIALITY	22
SECTION 25	DISPUTE RESOLUTION	22
SECTION 26	TAXES	23
SECTION 27	WAIVER	23
SECTION 28	NO THIRD PARTY BENEFICIARIES	23
SECTION 29	FORCE MAJEURE	23
SECTION 30	ASSIGNMENT	23
SECTION 31	APPLICABLE LAW	24
SECTION 32	WAIVER OF JURY TRIAL	24
SECTION 33	ENTIRE AGREEMENT, MODIFICATIONS, SURVIVAL CONFLICTS AND TARIFFS	24
SECTION 34	AUTHORITY, COUNTERPARTS AND ELECTRONIC SIGNATURES	25

ATTACHED AND INCORPORATED EXHIBITS

EXHIBIT A – DEFINITIONS

EXHIBIT B – FORM APPLICATION FOR POLE LICENSE

EXHIBIT C – NOTIFICATION OF SURRENDER OF LICENSE

EXHIBIT D – SCHEDULE OF RATES, FEES AND CHARGES

EXHIBIT E – NOTICE CONTACTS AND ADDRESSES

1. PARTIES.

This Pole Attachment License Agreement (“Agreement”) is entered into as of the date last signed by all the parties (“Effective Date”) by and between Windstream Kentucky East, LLC, a Windstream company organized and existing under the State of Delaware (“Licensor”), and CMN-RUS, Inc., a company organized and existing under the State of Indiana (“Licensee”). Licensor and Licensee may sometimes be referred to in this Agreement individually as a “party” and collectively as the “parties”.

2. SCOPE.

A. The purpose of this Agreement is to set forth the rates, terms, conditions, and procedures under which the Licensor will provide Licensee access to Licensor’s Poles (as defined herein) in the State of Kentucky for the purpose of Licensee attaching wireline facilities.

B. The parties acknowledge that Licensor is entering into this Agreement because Licensee has represented it is a regulated "telecommunications carrier" or “cable television system” provider as such terms are defined in the Communications Act of 1934, as amended (hereinafter the "Communications Act") and desires to provide telecommunications service or cable service (“Services”), as defined in the Communications Act; and that Licensee is authorized to provide these Services under its franchise or other lawful authority within its service area where Licensor owns Poles. In the event Licensee no longer has the status as a “telecommunications carrier” or “cable television system” provider or the authority to offer these Services in the state where the Poles are located, Licensor shall have the right to immediately terminate this Agreement and require Licensee to remove all of its facilities from Licensor’s Poles. **As a condition precedent to entering into this Agreement, Licensee shall submit to Licensor a copy of its certification evidencing its status as either a regulated telecommunication carrier or cable television system provider, and until such documentation is provided to Licensor, Licensor shall not be obligated to enter into this Agreement.**

C. Subject to the provisions of this Agreement, Licensor will issue to Licensee for any lawful communications purpose, revocable, nonexclusive Licenses authorizing the placement of Licensee's Attachment to Licensor's Poles.

D. No use, however extended, of Licensor's Poles nor payment of any fees or charges required under this Agreement or License issued under this Agreement shall create or vest in Licensee any ownership or property rights in said Poles, but Licensee's rights therein shall be and remain a mere license. Nothing herein contained shall be construed to compel Licensor to construct, retain, extend, place, or maintain any facilities not needed for its own service requirements, unless otherwise required by law. Nothing contained in this Agreement or in any License issued hereunder shall in any way affect, restrict or impair the right of Licensor to convey, transfer, mortgage, or assign to any other person or entity any interest in real or personal property, including any Poles in which Licensee has attached or placed Licensee’s Attachments pursuant to Licenses issued under this or other license agreements.

E. Licensee recognizes that Licensor has entered into, or may in the future enter into, agreements and arrangements with others which are not a party to this Agreement regarding the Poles covered by this Agreement. Nothing herein contained shall be construed as a limitation, restriction or prohibition against Licensor with respect to such other agreements or arrangements. The rights of Licensee shall at all times be subject to any preexisting joint use or joint ownership arrangement between Licensor and any other party. Licensor and Licensee agree that this Agreement will be subject to any future joint use or joint

ownership arrangement between Licensor and any other party to the extent such future agreements do not materially and negatively prevent Licensee from exercising its rights under this Agreement. However, Licensee also understands and agrees that the act of Licensor providing pole access to third parties in the future shall not in and of itself be deemed to be an act that materially and negatively prevents Licensee from exercising its rights under this Agreement.

F. This Agreement does NOT create any right for Licensee to access or place facilities in Licensor central offices, conduit or to place wireless communication equipment on Poles. A separate agreement is required for any access to Licensor facilities other than those outlined in this Agreement.

3. DEFINITIONS.

Certain capitalized terms used in this Agreement are listed in and have the meaning as set forth in Exhibit A. Exhibit A is incorporated and made a part of this Agreement by reference.

4. TERM AND TERMINATION OF AGREEMENT

A. This Agreement shall become effective upon the Effective Date and if not terminated in accordance with the provisions of this Agreement, shall continue in effect for a term of ten (10) years (“Initial Term”) and shall continue on a year –to – year basis. Notwithstanding the foregoing, any time after the initial year of the Initial Term and anytime thereafter the rates, fees and charges set forth may be increased or decreased by written notice from Licensor to Licensee.

B. Either Party may terminate this Agreement for any reason at the end of the Initial Term with at least six (6) months written notice to the other party; provided however, that this Agreement will remain in effect until a successor agreement becomes effective or the Attachments have been removed from the poles, whichever occurs first. A party may terminate this Agreement in the event of default as set forth under Article 20 of this Agreement.

C. Upon termination of the Agreement in accordance with any of its terms, all outstanding Licenses in connection therewith shall terminate and shall be surrendered and Licensee shall immediately, and at its sole expense remove all Attachments located on Poles within one hundred twenty (120) days of date of termination or within such other mutually agreeable timeframe.

5. TERMINATION OF LICENSES

A. In addition to other termination rights set forth in this Agreement, upon notice from Licensor to Licensee that Licensor has been advised by a governmental authority or private property owners (1) that the use of any Poles is not authorized and is objected to by such governmental authority or private property owner, and all reasonable appeals have been exhausted; or (2) that any Pole is to be removed, sold or otherwise disposed of, Licensee shall promptly remove its cables, equipment, and facilities at once from the affected Poles or shall make arrangements for the removal of its cable, equipment, and facilities from the affected portion of Licensor's Poles at Licensee's sole expense. If not so removed within sixty (60) days or such timeframe as stated on the Notice, Licensor shall have the right to remove Licensee's Attachments from Licensor's Poles at the reasonable and actual cost and expense of Licensee and without any liability thereto.

B. Licensee may at any time remove its Attachments from any Poles of Licensor, but shall promptly give Licensor written notice of such removal and surrender of License in the form of a Notification of Surrender attached hereto as Exhibit C and incorporated by reference and made a part of this Agreement. If Licensee surrenders its License but fails to remove its Attachments from Licensor's Poles, Licensor shall have the right but not the obligation to remove Licensee's Attachments at Licensee's expense without any liability on the part of Licensor for damage or injury to Licensee's Attachments or interruption to Services. Licensee's obligations with regard to maintenance and fees continue until Attachments are removed from the Poles. In the event that Licensee's Attachments shall be removed from any Poles as provided by this Agreement, no Attachment shall again be made to such Poles unless Licensee shall have first complied with all of the provisions of this Agreement as though no Attachment had previously been made.

6. RATES, FEES AND CHARGES.

A. All rates, charges and fees set forth in this Agreement and those shown in Exhibit D (Schedule of Rates, Fees, and Charges) shall be subject to and calculated in accordance with applicable law, rules, regulations and commission orders, and Licensor may in its sole discretion revise the rates, charges and fees as set forth in Exhibit D upon sixty (60) days written notice to Licensee in accordance with Section 4.A. Exhibit D is incorporated and made a part of this Agreement by reference. The fees, rates and charges set forth in Exhibit D or elsewhere in this Agreement are effective during the term of this Agreement and subject to change as set forth herein.

B. Pole Attachment Fee. For the purpose of computing the annual Pole Attachment Fee due under this Agreement the Pole Attachment Fee shall be based each year upon the number of Poles where Licensor has issued a License as of the date of annual billing multiplied by the Attachment Rate set forth on Exhibit D, as may be modified by Licensor from time to time.

C. All charges for inspections, engineering, replacement or rearrangements of Licensee's Attachments from Licensor's Poles and, without limitation, any other work performed for Licensee shall be based upon the full reasonable and actual cost and expense, including reasonable overhead, incurred by Licensor or its representative for performing such work for Licensee to include without limitation costs to transfer or moving of Licensor facilities and removal of old Poles. The cost to Licensee shall be determined in accordance with the regular and customary methods used by Licensor in determining such costs.

D. All other Attachment related inquiry, verification, application, administrative and miscellaneous rates, fees and charges shall be calculated and paid in accordance with Exhibit D and the terms of this Agreement.

E. Upon termination or surrender of a License granted hereunder, no refund of any Pole Attachment Fees shall be made and Licensee shall remain liable for all fees and charges set forth in this Agreement until Licensee has removed its Attachments.

7. PAYMENT, SECURITY BOND AND LIEN.

A. All bills for such other charges for work performed by Licensor and the fees set forth in the Agreement shall be payable upon presentment to Licensee, and shall be deemed delinquent if not paid within thirty (30) days after the receipt of the invoice.

B. Bond. Licensee shall furnish a bond or other security, and keep in place during the term of this Agreement, satisfactory to Licensor, the amount of \$5,000 or an amount equal to two (2) years of Pole Attachment Fees, whichever is greater, to guarantee the performance of Licensee obligations including payment of any such sums (including Unauthorized Attachment charges and liquidated damages) which may become due to Licensor arising out of this Agreement including, but not limited to rent, fees due hereunder or charges for work performed for the benefit of Licensee under this Agreement, including the removal of Licensee's facilities upon termination of this Agreement by any of its provisions or upon termination of any License issued hereunder. Such bond shall include that Licensor received 30 days prior notice of cancellation. Cancellation of a bond shall be an event of default by Licensee. Upon signing this Agreement and prior to issuance of a License, Licensee shall furnish the bond to be sent to person identified in Exhibit E. Licensor may in its sole discretion change the bond amount or cancellation notice requirement from time to time upon at least thirty (30) day notice to Licensee. Licensor shall not be obligated to issue any License hereunder until Licensee has provided the bond as set forth herein.

C. Lien. Should Licensor under the terms and conditions of this Agreement, and due to Licensee's failure to do so after receiving appropriate notice, remove Licensee's Attachments from Licensor's Poles, Licensor will deliver to Licensee the cable, equipment or facilities so removed upon payment by Licensee of the reasonable and actual cost of removal, storage and delivery, and all other amounts due Licensor hereunder. Licensor is hereby given a lien on Licensee's cable, equipment or facilities attached to Licensor's Poles or removed therefrom, with power of public or private sale, to cover any amounts due Licensor under the provisions of this Agreement. Such liens shall not operate to prevent Licensor from pursuing, at its option, any other remedy in law, equity or otherwise, including any other remedy provided for in this Agreement.

8. ATTACHMENT REQUEST AND LICENSE PROCESS

A. Before Licensee shall have a right to place Attachments to any Poles of Licensor, Licensee shall make application for and receive a revocable, nonexclusive License which shall be in the form of a Licensor countersigned Application for Pole License (Exhibit B). Each Exhibit B Application for Pole License shall contain no more than twenty-five (25) Poles and Licensee may submit up to twelve (12) Exhibit B, Application for Pole License within a rolling thirty (30) day period. Licensor will process Applications for Pole Licenses in the order in which they are received; provided, however, that when Licensee has multiple Applications for Pole Licenses on file with Licensor, Licensee may designate its desired priority of completion with respect to all such Application for Pole Licenses. **Licensee shall not under any circumstances attach any equipment to any guy wires or anchors owned by Licensor.**

B. Application For Pole License and Engineering Survey. Licensee shall submit an Application for Pole License in the form of Exhibit B and shall include a drawing of the proposed route, the pole detail and contact information (name, telephone, facsimile, and email information). Upon receipt of a complete Application for Pole License, Licensor will conduct an engineering survey to determine whether and where Licensee's Attachment is feasible, and what Make Ready Work is required by Licensor or other existing attachers to accommodate Licensee's Attachment. Within forty-five (45) days of receipt of Licensee's Application, Licensor shall inform Licensee of its estimated make-ready charges for Licensor Make Ready Work ("Make Ready Estimate"). If during this process, Licensor determines the request is denied based on insufficient capacity or for reasons of safety, reliability and generally applicable engineering purpose Licensor shall inform Licensee that the Application for Pole License is denied together with the reason and Licensee may consider possible alternatives and revise and resubmit the

Application for Pole License for approval. All reasonable and actual expenses incurred by Licensor in reviewing Licensee's Application for Pole License shall be borne by Licensee even if such request is denied by Licensor. If Licensor does not complete its survey work within forty-five (45) days, Licensee shall have the option to utilize Licensee Contractors to complete the surveys.

C. Advance Payment of Make Ready Work Estimate and Expedited Charges. If Licensee upon review of the Make Ready Estimate desires to proceed with the process to obtain a License from Licensor, Licensee shall submit payment in the amount of the Make Ready Estimate together with the Application Fee and engineering survey costs to Licensor within fourteen (14) days of receipt of the Make Ready Estimate and invoice for such amounts. Licensee shall be solely responsible for negotiating with existing attachers for Make-Ready Work relating to such other existing attacher facilities located on, within or in Licensor's Poles and shall be responsible for paying all charges incurred in transferring or rearranging existing attacher facilities to accommodate the placement of Licensee's Attachment on, within or in Licensor's Poles. In the event, Licensee declines to proceed with the project Licensee shall reimburse Licensor any reasonable and actual costs and expenses incurred by Licensor to date including but not limited to Application Fee, engineering and administrative expenses and costs.

D. Completion of Make Ready Work and Issuance of License. Licensor shall undertake to complete any Make Ready Work of its owned facilities upon receipt of Licensee's payment of the Make Ready Estimate. Make Ready Work shall be completed within sixty (60) days or, if power space must be accessed, within ninety (90) days of receipt of payment. Upon completion of all Make Ready Work and receipt of all fees and charges due from Licensee to Licensor, Licensor shall issue Licensee an approved License which shall be in the form of a Licensor countersigned Application for Pole License. At that time Licensee will be considered to have been granted a License with respect to the Poles approved in the License and may attach to Licensor's Poles in accordance with the terms and conditions of this Agreement. If Licensor does not complete the Make Ready Work within the aforementioned timeframes, Licensee shall have the option to utilize Licensee's Contractors qualified or approved by Licensor to complete the Make Ready Work.

E. Licensee shall maintain a copy of all Application for Pole Licenses and approved Licenses. Licensor may provide upon request copies of the same to the extent available and Licensee shall reimburse Licensor for its reasonable and actual costs in preparing and sending requested copies.

9. AUTHORITY FOR PLACEMENT OF ATTACHMENT

A. Before any placement of Attachments by Licensee, regardless of whether a License may have been issued, Licensee represents and warrants that it has the authority to maintain Attachments within public rights-of-way, or on private rights-of-way or on private property, and shall upon request provide a copy of documentation evidencing such right to Licensor. Licensee shall be solely responsible for obtaining all licenses, easements, authorizations, permits and consents from federal, state and local authorities or private land owners that may be required to place and maintain Attachments on Licensor's Poles.

B. Licensor and Licensee agree that neither party has the right to restrict or interfere with the other party's lawful access to and use of public right-of-way, including public right-of-way, which pass over property owned by either party. Except as otherwise specifically provided in this Agreement, Licensor and Licensee shall each be responsible for obtaining their own right-of-way and permission to use real or personal property owned or controlled by any governmental body or private entity or person.

C. Licensor may, without incurring any liability, remove Attachments of Licensee from Licensor's Poles, at Licensee's sole expense where in Licensor's sole judgment such removal constitutes an emergency and such removal is required in connection with the performance of Licensor's service obligation or the safety of Licensor's employees. Whenever such emergency removal has occurred, Licensor shall use commercially reasonable efforts to notify Licensee as expeditiously as possible following such removal. If the situation does not, in Licensor's reasonable judgment, constitute an emergency, Licensor shall provide written notice to Licensee and a mutually agreeable remediation timeline will be determined.

10. CONSTRUCTION AND MAINTENANCE

A. Licensee's Attachments shall be placed and maintained in accordance with the following:

- 1.** any and all reasonable Licensor requirements and specifications of Licensor provided to Licensee in writing and with reasonable advance notice, and
- 2.** the terms and conditions of this Agreement, and
- 3.** the National Electric Safety Code (most recent edition), and
- 4.** the National Electric Code (most recent edition), and
- 5.** in compliance with any other rules or orders now in effect or that may hereafter be issued by any state utility commission or other authority (state, federal, local) having jurisdiction over including but not limited to Poles, rights-of-way, and Hazardous Materials.

Each of Section 10(A)(1-5) is incorporated by reference and made a part of this Agreement, and in the event of a conflict or difference between any of these specifications and requirements, the more stringent will apply. Changes to the standards in Sections 10(A)(1, 3-5) shall not apply retroactively unless required by law. Licensee agrees to rearrange its Attachments, within a commercially reasonable timeframe, in accordance with changes in the standards referenced herein in this Section 10(A) of this Agreement, or if required by law.

B. Licensee shall, at its own expense, make and maintain its Attachments and use Licensor Poles in a safe condition and in thorough repair, and in a manner acceptable to Licensor, and so as not to conflict with the use of said Poles by Licensor or by other authorized users of said Poles, or interfere with other facilities thereon or which may from time to time be placed thereon. Licensee shall, at its sole expense, upon written notice from Licensor, relocate or replace its Attachments placed on said Poles or transfer them to substituted Poles that may be authorized by Licensor, or perform any other work in connection with said Attachments that may be required. If Licensor undertakes a project that requires a relocation or replacement of Licensee's Attachments, the cost of relocating or replacing the Licensee's Attachments shall be borne as follows: (a) by Licensee if the relocation or replacement is for Licensee's benefit; (b) by Licensee if the relocation or replacement is due to or mandated by any applicable law or regulation, judicial opinion or governmental order; or (c) by a third party if the relocation or replacement is for the third party's benefit. Licensor shall give such written notice as is reasonable in the circumstances, provided, however, that in cases of emergency, as determined by Licensor in its sole discretion, Licensor may arrange to relocate, remove or replace Licensee Attachments placed on said Poles, transfer such Attachments to substituted Poles or perform any other work in connection with said Attachments that may be required in the maintenance, replacement, removal or relocation of said Poles or pre-existing Licensor or attacher facilities thereon, and Licensee shall reimburse Licensor for the reasonable and actual expense thereby incurred. For the purpose of this Section, Licensee Attachments shall be

understood to include Attachments of Licensee in space reserved for Licensor, or space which Licensor has the right to use, on poles of other companies with which Licensor now has or may hereafter have agreements for joint use and occupancy; and the use of such space by Licensee shall be subject to the terms and conditions of the agreements between Licensor and said other companies.

C. Licensee shall be responsible at all times for the condition of Licensee's Attachments and its compliance with the requirements, specifications, rules, regulations, ordinances and laws specified in this Agreement. Licensor shall have no duty to Licensee to inspect, monitor or maintain the condition of Licensee's Attachments (including, but not limited to, splices and other facilities connections) located on, within or in Licensor's Poles. Licensor may make periodic or spot inspections at any time of any part of Licensee's Attachments as Licensor determines reasonable or necessary in its sole judgment, pursuant to Section 16 of this Agreement.

D. Licensee shall not authorize any person or entity acting on Licensee's behalf ("Licensee Contractor") to perform any work on, within or in Licensor's Poles without such person or entity first verifying, to the extent practicable, on each date when such work is to be performed and, that the condition of the Poles is suitable for the work to be performed. If Licensee or Licensee Contractor determines that the condition of the Poles is not suitable for the work to be performed, Licensee shall notify Licensor of the condition of the Poles in question and shall not proceed with construction activities until Licensee is satisfied that the work can be safely performed.

E. Licensee shall be solely responsible for paying all persons and entities that provide materials, labor, access to real or personal property, or other goods or services in connection with the construction and placement of Licensee's Attachments and for directing the activities of all Licensee Contractors while they are physically present on, within or in the vicinity of Licensor's Poles. Licensee shall not permit any mechanic's lien, material man's lien, or any other lien, claim or security interest to attach to or encumber any of Licensor's real or personal property at any time.

F. Licensee's main line Attachments shall be tagged at maximum intervals of 300 feet so as to identify Licensee as the owner of the Attachment. Licensee shall place fiber wrap/ID at the specific Licensor Poles attaching point and at any aerial span splice location and/or slack loop. The tags shall be of sufficient size and lettering so as to be easily read from ground level.

11. OVERLASHING; SERVICE DROPS

A. Licensee may, upon notice to Licensor, overlash its own existing authorized Attachment and this does not constitute a separate Attachment, as it relates to the billing of Pole Attachment Fees, unless multiple/separate Attachment points are physically made at the Poles itself outside of the scope of a single Attachment. Such notice shall be in the form of an Exhibit B Application for Pole License, and any additional Attachments being installed on Poles, regardless of it being an overlash of existing Attachment or as a new Attachment, will require an engineering analysis to determine if the additional loading negatively impacts the Poles capacity. Any additional load which causes the Pole to exceed its rated capacity or no longer provides for ample ground clearance of the Attachments or other facilities will necessitate the need for the Licensee to pay any and all Make Ready Work necessary. Each overlashed strand shall not exceed a 2" maximum diameter.

B. In no event shall Licensee allow a third party to overlash to Licensee's Attachments without prior notice to and consent from Licensor. Any third party must execute a License Agreement with Licensor and obtain a license thereunder.

C. Licensee shall have the right to install Service Drops without approval by Licensor and will provide notice of such Service Drops within ten (10) days of their installation. "Service Drop" means any telecommunications line or facility that originates from and is attached to Licensor's Pole(s) and ends at a house, business or other connection.

12. MODIFICATIONS, ADDITIONS, REPLACEMENTS OR REARRANGEMENTS

A. Licensee shall not modify, overlash, add to, or replace Attachments on any Poles without first notifying Licensor in writing of the intended modification, addition or replacement at least thirty (30) days prior to the date the activity is scheduled to begin. Notwithstanding the foregoing, the aforementioned modifications shall not include Service Drops, emergency repairs or routine maintenance including like-for-like replacements. The required notification shall include:

1. the date the activity is scheduled to begin including the Pole location and Pole number,
2. a description of the planned modification, addition, or replacement,
3. a representation that the modification, addition, or replacement will not require any space other than the space previously designated for Licensee's Attachments, and
4. a representation that the modification, addition, or replacement will not impair the structural integrity of the Poles involved.

B. Upon Licensor's receipt of a complete Exhibit B Application for Pole License, Licensor will perform, at Licensee's sole expense, a field check and if Licensor determines that the modification, addition, or replacement specified by Licensee in its notice will require more space than that allocated to Licensee or will require the rearrangements of, reinforcement of, replacement of, or an addition of support equipment to the Poles involved in order to accommodate Licensee's modification, addition, or replacement, Licensor will so notify Licensee within forty-five (45) days of receipt of Application and the parties will follow the Make Ready Work process as set forth in Section 8 of this Agreement in order to obtain authorization for the modification, addition, or replacement of its Attachments.

C. Should Licensee request Licensor to expand capacity or purchase additional plant and should Licensor so agree, Licensee agrees to pay all reasonable and actual cost and expenses thereby incurred by Licensor. If another party that has been granted a license joins in the request or will benefit from the expansion or purchase, Licensee agrees to pay a percentage of all reasonable and actual costs proportionate to Licensee's share of the benefit received from the expansion or purchase, but Licensee shall be responsible for all costs and expenses not paid by the other party, except for costs and expenses related to remedying such other party's violations.

D. When multiple applications, including those of Licensee, are received by Licensor with respect to any Poles which must be replaced or rearranged to provide additional space prior to commencement of the work on such Poles, Licensor's facilities may need to be transferred in which case Licensor will equitably prorate to the extent that it is practical between Licensee and other applicants the reasonable and

actual expenses incurred by Licensor, if any, which result. Licensee shall be bound by Licensor's determination as to any such proration.

E. In the event Licensor plans to modify or alter any Poles upon which Licensee has placed Attachments, Licensor, except in emergency situations, shall provide Licensee written notice of the proposed modification or alteration at least sixty (60) days prior to the time the proposed modification or alteration is scheduled to take place. Should Licensee decide to modify or alter Licensee's Attachments on Poles, Licensee shall so notify Licensor in writing at least thirty (30) days prior to the day the work is to begin. In such event, Licensee shall bear a proportionate share of the total reasonable and actual costs incurred by Licensor to make Licensor Poles accessible.

F. In the event Licensor is required to move the location of, or replace, any Licensor Poles for reasons beyond its control, Licensee concurrently shall relocate Licensee's Attachments. Licensee shall be solely responsible for the costs of the relocation of Licensee's Attachments. When it is mutually agreed that it is in the best interest of Licensor and Licensee, Licensor may, after proper notification has been provided, transfer Licensee's Attachments at the same time that Licensor transfers its facilities and shall invoice Licensee for the reasonable and actual costs incurred in performing the transfer of Licensee's Attachments.

13. EMERGENCY RESTORATION

A. In the event of an emergency, restoration procedures may be affected by the presence of Licensee's Attachments. While Licensor shall not be responsible for the repair of damaged Attachments, Licensor shall nonetheless control access to its Poles if the restoration is to be achieved in an orderly fashion.

B. Where Licensor and Licensee are involved in emergency restorations, access to Licensor's Poles will be controlled by Licensor according to the following guidelines.

1. Service Disruptions/Outages

- a) While exercising its right to first access, Licensor shall make all reasonable efforts to grant access to as many other entities with attachments as is reasonably safe.
- b) Where simultaneous access is not possible, Licensor will grant access on first come, first served basis.

2. Service Affecting Emergencies

- a) While exercising its right to first access, Licensor shall make all reasonable efforts to grant access to as many other entities with attachments as is reasonably safe.
- b) Where Licensor is unable to grant simultaneous access to all other entities with attachments, access will be granted according to the level of damage to the attachments of each entity and the likelihood that a given level of damage will

result in service disruption. Where the likelihood that a service disruption will result is not clearly discernible, access will be on a first come, first served basis.

C. Without limiting any other indemnification or hold harmless provisions of this Agreement, Licensee agrees that any decision by Licensor regarding access to its Attachments, or any action or failure to act by Licensor, under this section shall not be the basis for any claim by Licensee against Licensor for any damage to Licensee's Attachments or disruption of Licensee's Services, or any other direct or indirect damages of any kind whatsoever incurred by Licensee, except in the case of the gross negligence or willful misconduct of Licensor.

14. FAILURE TO PLACE ATTACHMENTS

Once Licensee has been issued a License, Licensee shall have one hundred twenty (120) calendar days from the date of the License was issued to begin the placement of its Attachments on the Licensor Poles covered by the License. If Licensee has not begun placing its Attachments within the one hundred twenty (120) day period, Licensee shall so advise Licensor with a written explanation and notice for the delay. If Licensee fails to advise Licensor of its delay by notice thereof or if Licensee fails to act in good faith by not making a bona fide effort to begin placing its Attachments within the one hundred twenty (120) calendar days prescribed by this section, the License shall be automatically rescinded by Licensor and deemed null and void, and Licensee shall have no further right to place the Attachments pursuant to such voided License.

15. ABANDONMENT

Nothing in this Agreement shall prevent or be construed to prevent Licensor from abandoning, selling, assigning, or otherwise disposing of any Poles. Licensor shall notify Licensee of any sale, assignment, or other disposition of any Poles or other Licensor property used for Licensee's Attachments. Licensee shall have the option but not the obligation to purchase any assets slated for abandonment unless such option has previously been granted to and exercised by another license.

16. INSPECTIONS AND INVENTORIES

A. **Post construction and/or periodic inspection of Licensee Attachments.** Licensor shall have the right, but not the obligation, to make a post construction inspection and periodic inspections at any time of any part of Licensee's Attachments on Poles and any other associated facilities for the limited purpose of determining whether Licensee's Attachments are in compliance with the terms of this Agreement and any Licenses issued hereunder. Such inspections shall be conducted at Licensor's expense with the exception of (1) a post construction inspection performed within ninety (90) days of completion of Licensee's installation of its attachments, (2) follow-up inspection within ninety (90) days of completion of Licensee's remedial action to confirm such remedial action after an observed Licensee violation of the requirements of this Agreement; and (3) inspection of Licensee Facilities in compliance with a specific mandate of appropriate governmental authority, for which inspections the reasonable and actual cost shall be borne solely by Licensee.

B. **Inventories.** Upon written notice to Licensee, the total number and location of Licensee's Attachments on Licensor's Poles may be determined, at Licensor's discretion, through a survey which may be made not more than once every five years by Licensor. If so requested, Licensee and /or any other entity owning or jointly using the Poles with Licensor may participate in the survey. The actual and

reasonable costs incurred by Licensor to conduct the survey shall be reimbursed to Licensor by Licensee upon demand by Licensor regardless of whether or not Licensee participates in the survey. If the Attachments of more than one licensee and/or Licensor (if included in the survey) are surveyed, each such licensee and Licensor shall contribute a proportionate share of the actual and reasonable costs reimbursed to Licensor based on the number of poles to which each is attached.

C. No Duty to Licensee. Neither the act of inspection or survey by Licensor of Licensee's Attachments nor any failure to inspect such Attachments shall operate to impose on Licensor any liability of any kind whatsoever or to relieve Licensee of any responsibility, obligations or liability under this Agreement, any License issued hereunder, or applicable law, or to any third party contractor, Licensee Contractor, or otherwise.

17. UNAUTHORIZED ATTACHMENTS

A. If any Licensee Attachment shall be found on Poles for which no License has been granted by Licensor pursuant to the terms of this Agreement ("Unauthorized Attachment"), Licensor, without prejudice to its other rights or remedies under this Agreement or otherwise, may:

1. impose charges as set forth herein, and
2. after reasonable notice and opportunity to cure, require Licensee to remove such Unauthorized Attachment or Licensor may remove such Unauthorized Attachment without liability and the reasonable and actual expense of removal shall be borne by Licensee.

B. For the purpose of determining the charges, Licensee shall pay an amount per Unauthorized Attachment equal to the Pole Attachment Fee that would have applied if Licensee had properly obtained a License based upon the then current Attachment Rate for the number of years the Unauthorized Attachment have existed (or, if that cannot be determined, the number or years since the most recent inventory or five (5) years, whichever is less), plus interest at a rate the greater of 1.5% per month or the maximum allowed by law. In addition, if the Unauthorized Attachment is discovered during a survey where Licensee declined to participate an additional fee of [REDACTED] per Unauthorized Attachment shall be charged to Licensee. Licensee agrees and acknowledges in the event of an Unauthorized Attachment actual damages would be difficult to determine and the charges described herein are liquidated damages, not penalties, and represent a fair and reasonable estimate of the damages which may be incurred by Licensor for Unauthorized Attachments on Licensor's Poles including wear and tear, lost revenue, increased maintenance and repair costs for having to work on a Pole where the owner of a facility is unknown, and the risk of liability for safety violations that may be the result of an Unauthorized Attachment.

C. Any such charge as set forth in Section 17(B) imposed by Licensor shall be in addition to its rights to any other sums due and payable, including without limitation Make Ready Work costs, the reasonable and actual costs of any audit or survey which established the existence of the Unauthorized Attachment and to any claims to said fees.

D. No act by Licensor with regard to any unauthorized use shall be deemed as a ratification or the licensing of the unauthorized use, and if any License should subsequently be issued, after application and payment of all applicable fees therefore, said License shall not operate retroactively or constitute a waiver

by Licensor of any of its rights or privileges under this Agreement or otherwise, and Licensee shall be subject to all liabilities, obligations and responsibilities of this Agreement in regard to said unauthorized use from its inception.

E. An Unauthorized Attachment shall include, but not limited to:

1. an Attachment to Poles (other than Service Drops) which is not identified in any License issued in accordance with this Agreement;
2. an Attachment that occupies more space than that allocated to Licensee by Licensor in a License;
3. an Attachment that is not placed in accordance with the provisions of this Agreement or the appropriate License issued pursuant to this Agreement, unless Licensee can demonstrate to Licensor's reasonable satisfaction that said misplacement is not due to any act or omission of Licensee or Licensee's agents;
4. an addition or modification by Licensee to its pre-existing Attachment(s) that impairs the structural integrity of the involved Licensor Poles.
5. an Attachment that consists of facilities owned or controlled by, and for the use of a party other than Licensee that is overlashed to Licensee Attachments without approval by Licensor as required under this Agreement.

F. Once Licensor has notified Licensee of an Unauthorized Attachment. Licensee shall submit an Exhibit B Application for Pole License to request an authorization for the Attachment. An Exhibit B Application for Pole License submitted per this provision will be treated like any other Exhibit B Application for Pole License subject to this Agreement. Licensee will be responsible for all fees associated with an Exhibit B Application for Pole License (as identified in this Agreement). If an Exhibit B Application for Pole License is not received by Licensor within thirty (30) days of Licensor's notice of an Unauthorized Attachment, Licensee has sixty (60) days from the date of the Unauthorized Attachment notification to vacate the Pole. If Licensee fails to remove Licensee's facilities within such sixty (60) day period, Licensor shall have the right to remove Licensee's facilities at Licensee's expense and without any liability on the part of Licensor for damage or injury to Licensee's facilities or disruption of Licensee's Services.

18. COMPLIANCE WITH LAW, ASSUMPTION OF RISK, AND DISCLAIMER OF WARRANTIES

A. Notwithstanding anything to the contrary in this Agreement, Licensee shall ensure that any and all activities it undertakes pursuant to this Agreement shall comply with all applicable laws, including, without limitation, all applicable provisions of:

1. Workers' compensation laws
2. Unemployment compensation laws
3. The Federal Social Security Law

4. The Fair Labor Standards Act, and

5. All laws, regulations, rules, guidelines, policies, orders, permits and approvals or any governmental authority relating to environmental matters including but not limited to Hazardous Materials and/or Occupational Safety and Health Act (“OSHA”).

B. LICENSEE ACKNOWLEDGES AND AGREES THAT LICENSOR DOES NOT MAKE ANY REPRESENTATION OR WARRANTIES AS TO THE CONDITION OR SAFETY OF LICENSOR’S POLES OR ANY ASSOCIATED FACILITIES AND EQUIPMENT ON, WITHIN OR SURROUNDING THE SAME OR THE PREMISES SURROUNDING THE SAME. EXCEPT TO THE EXTENT OF LICENSOR’S NEGLIGENCE, LICENSEE HEREBY ASSUMES ALL RISKS OF ANY DAMAGE, INJURY OR LOSS OF ANY NATURE WHATSOEVER CAUSED BY OR IN CONNECTION WITH THE USE OF POLES AND ASSOCIATED FACILITIES AND EQUIPMENT ON, WITHIN OR SURROUNDING THE SAME, AND THE PREMISES SURROUNDING THE SAME AND LICENSEE IS SOLELY RESPONSIBLE FOR ALL ALLEGED DAMAGES CLAIMED BY THIRD PARTIES UNDER THE CONTROL OR DIRECTION OF LICENSEE ACCESSING OR WORKING ON OR NEAR LICENSOR’S POLES.

C. EXCEPT AS OTHERWISE PROVIDED HEREIN, LICENSOR MAKES NO WARRANTIES, EXPRESS OR IMPLIED, INCLUDING BUT NOT LIMITED TO THE WARRANTIES OF MERCHANTABILITY OR FITNESS FOR A PARTICULAR PURPOSE, ALL OF WHICH ARE HEREBY EXPRESSLY DISCLAIMED, WITH REGARD TO THIS AGREEMENT AND ANY LICENSE ISSUED HEREUNDER INCLUDING, WITHOUT LIMITATION, ACCESS TO LICENSOR’S POLES OR OTHER FACILITIES.

19. LICENSEE CONTRACTOR QUALIFICATIONS

A. The parties acknowledge that from time to time Licensee may use a Licensee Contractor to perform work for Licensee on, within or in Licensor’s Poles.

B. Licensee represents and warrants that any of its employees or Licensee Contractors shall not climb or work on any of Licensor’s Poles, or work within Licensor’s Right-Of-Way unless such person has the training, skill, and experience required to recognize potentially dangerous conditions relating to Poles and to perform the work safely.

C. Licensee assumes all risk of Licensee Contractors and agrees to indemnify, defend and hold harmless Licensor from all claims, losses, damages and liabilities, reasonable and actual costs and expenses (including, but not limited to, reasonable attorney’s fees) associated thereto in accordance with the indemnification provision of this License Agreement.

D. When Licensee Contractors are working on, within or in the vicinity of any part of Licensor’s Poles or Right-Of-Way, all such Licensee Contractors shall follow procedures which Licensee deems appropriate for the protection of persons and property. Licensee shall be responsible at all times for determining and implementing the specific steps required to protect persons and property at the site. Licensee will provide all traffic control and warning devices required to protect pedestrian and vehicular traffic, workers and property from danger. Licensee has sole responsibility for the safety of all its

employees and Licensee Contractors, for the safety of bystanders, and for insuring that all operations conform to terms and conditions set forth in this Agreement. Licensor reserves the right to suspend Licensee's activities on, within or in the vicinity of Licensor's Poles or Right-Of-Way if, in Licensor's sole judgment, any hazardous condition arises due to the activity (including both acts and omissions) of any Licensee Contractor or Licensee employee, which suspension shall cease when the condition has been rectified.

E. Licensee represents and warrants that all Licensee Contractors shall maintain the same insurance coverage and limits as are required of Licensee under this Agreement, and if not Licensee's insurance will provide such coverage.

F. Licensee acknowledges that all Licensee Contractors are not Licensor's employees or agents and Licensee assumes full responsibility for their actions or omissions to act. Licensee shall be solely responsible for the payment of compensation of Licensee's employees, contractors or agents assigned to perform work hereunder and such employees, contractors and agents shall be informed that they are not entitled to the provision of any Licensor benefits. Licensor shall not be responsible for payment of workman's compensation, disability benefits, and unemployment insurance or for withholding or paying employment related taxes for any employee of Licensee, but such responsibility shall be solely that of Licensee. In the event that any federal, state or local government agency, any court or any other applicable entity determines that the personnel provided by Licensee or any permitted Licensee Contractor are employees of Licensor for any purpose, Licensee agrees to indemnify, defend and save harmless Licensor from all liabilities, reasonable and actual costs, and expenses (including, but not limited to, reasonable attorney's fees) associated with such determination in accordance with the indemnification provision of this License Agreement.

G. Except as otherwise agreed to in writing by the parties, any work by Licensee Contractors on, within or in Licensor's Poles or Right-Of-Way shall be done only when specific authorization for such work has been obtained in writing in advance from Licensor pursuant to the terms and conditions of this Agreement. The parties agree that all work shall be performed according to existing industry standards and practices and the requirements and specifications set forth in this Agreement and any License issued hereunder.

20. DEFAULT

A. In addition to other events of defaults defined anywhere else in this Agreement, any one of the following shall be deemed the occurrence of a default under this Agreement:

1. failure by Licensee to pay when due any fee or other sum required to be paid under the terms of this Agreement and such default continues for a period of ten (10) calendar days after written notice thereof to Licensee.
2. failure by either party to perform or observe any other material term, condition, covenant, obligation, or provision of this Agreement and such default continues for a period of thirty (30) days after written notice thereof from the other party (provided that if such default is not curable within a thirty (30) day period, the period may be extended if the party substantially commences to cure such default and proceeds diligently thereafter to effect such cure).

3. the filing of any tax or lien against Poles because of any act or omission by Licensee which is not bonded or discharged within thirty (30) days of the date of notice to Licensee that such lien has been filed;
4. Licensee's voluntary or involuntary bankruptcy;
5. Licensee's use or maintenance of its Attachments in violation of any law or regulation, or in aid of any unlawful act or undertaking;
6. if any authorization which may be required of Licensee by any governmental or private authority for the placement, operation, or maintenance of Licensee's Attachments is denied or revoked.

B. In the event of a default and subject to any other applicable provision of this Agreement, the non-defaulting party, without any further notice to the defaulting party (except where expressly provided for below or required by applicable law), may do any one or more of the following:

1. perform on behalf and at the expense of the defaulting party, any obligation of the defaulting party under this Agreement which the defaulting party has failed to perform and of which the non-defaulting party shall have given the defaulting party notice, the reasonable and actual cost of which performance shall be paid by the defaulting party to the non-defaulting party upon demand;
2. terminate the license(s) for the attachment affected by the default, or in the case of a pattern of material default, terminate this entire Agreement by giving sixty (60) days written notice of such termination to Licensee and remove Licensee's Attachments and store Licensee's facilities in a public warehouse or elsewhere at the expense of and for the account of Licensee without Licensor being deemed guilty of trespass or conversion, and without Licensor becoming liable for any loss or damages to Licensee occasioned thereby; or
3. exercise any other legal or equitable right or remedy that the non-defaulting party may have.

C. The defaulting party shall repay to the non-defaulting party upon demand any reasonable and actual costs and expenses incurred by the non-defaulting party (including, but not limited to, reasonable attorney's fees) in successfully enforcing this Agreement.

D. Upon termination of this Agreement by the non-defaulting party, the defaulting party shall remain liable to the non-defaulting party for any and all fees, other payments and damages which may be due or sustained in accord with this Agreement prior to such termination, all reasonable and actual costs, fees and expenses (including, but not limited to, reasonable attorney's fees) incurred by the non-defaulting party in pursuit of its remedies hereunder.

E. All rights and remedies of the non-defaulting party set forth in this Agreement shall be cumulative and none shall exclude any other right or remedy, now or hereafter allowed by or available under any statute, ordinance, rule of court, or the common law, either at law or in equity, or both.

21. INDEMNIFICATION AND LIMITATION OF LIABILITY

A. Each party agrees to defend, indemnify, protect and hold harmless the other and the other's officers, directors, employees, shareholders, successors, assigns, agents, affiliates, representatives, partners, and contractors from and against any and all third party claims, actions, administrative proceedings (including, without limitation, informal proceedings), judgments, damages, penalties, fines, cost, liabilities, interests, or loss, together with all other reasonable and actual costs and expenses for destruction of tangible property or personal injury, including death, suffered by or asserted against the indemnified party in any way directly arising out of activities undertaken pursuant to this Agreement by the indemnifying party or the presence of the indemnifying party's Attachment on the Poles (including, without limitation, the installation, construction, operation or maintenance of Licensee's Attachments or Licensor's attachment or the Poles, unless caused solely by the negligence or willful misconduct of the indemnified party or the affiliates, agents, officers, employees and assigns of the indemnified party). Each party expressly assumes all liability for actions by its affiliates, agents, officers, employees, or contractors. Notwithstanding anything to the contrary contained in this Agreement, each party will be responsible for injuries occurring to or damages suffered by their own employees or for worker's compensation claims filed by their own employees and will indemnify, defend and hold harmless the other party against such injuries, damages or claims made by the indemnifying party's employee(s), except to the extent such injuries, damages or claims were the result of the gross negligence or willful misconduct of the party (or its agents, customers, invitees, servants, vendors, materialmen or suppliers) claiming indemnification.

B. Notwithstanding anything to the contrary in this Agreement, each party further shall defend, indemnify and hold harmless the other party, its agents, officers, employees, and assigns from and against any third party claims, liabilities, losses, damages, fines, penalties, and costs whether foreseen or unforeseen, which the indemnified party suffers or incurs because of:

1. any discharge of Hazardous Materials resulting from acts or omissions of the indemnifying party, its Contractors or predecessor in interest;
2. acts or omissions of the indemnifying party or its agents, employees, or representatives in connection with any cleanup required by law, or
3. failure of the indemnifying party or its Contractors to comply with Environmental, Safety and Health Laws.

C. Licensee shall indemnify, protect, and hold harmless Licensor from and against any and all claims for copyright and/or patent infringement arising directly by reason of installation of Licensee's Attachments pursuant to this Agreement.

D. In the event of any claim, demand or litigation specified in the indemnity provision, the party to be indemnified (the "Indemnified Party") shall give prompt notice to the other party (the "Indemnifying Party") of such claim, demand or litigation. The Indemnifying Party shall have sole control of the defense of any action or litigation on such a claim or demand (including the selection of appropriate counsel) and all negotiations for the settlement or compromise of the same, except that the Indemnifying Party may not make any non-monetary settlement or compromise without the Indemnified Party's consent, which consent shall not be unreasonably withheld. The Indemnified Party shall cooperate with

the Indemnifying Party in the defense and/or settlement of any claim, demand or litigation. Nothing herein shall be deemed to prevent the Indemnified Party from participating in the defense and/or settlement of any claim, demand or litigation by the Indemnified Party's own counsel at the Indemnified Party's own expense.

E. NOTWITHSTANDING ANYTHING TO THE CONTRARY CONTAINED IN THE AGREEMENT, NEITHER PARTY SHALL BE LIABLE TO THE OTHER PARTY FOR CONSEQUENTIAL, INCIDENTAL, PUNITIVE, EXEMPLARY OR INDIRECT DAMAGES SUFFERED BY SUCH PARTY OR BY ANY SUBSCRIBER, CUSTOMER OR PURCHASER OF SUCH PARTY FOR LOST PROFITS OR OTHER BUSINESS INTERRUPTION DAMAGES, WHETHER BY VIRTUE OF ANY STATUTE, IN TORT OR IN CONTRACT, UNDER ANY PROVISION OF INDEMNITY, OR OTHERWISE, REGARDLESS OF THE THEORY OF LIABILITY UPON WHICH ANY SUCH CLAIM MAY BE BASED OR WHETHER IT (a) HAS BEEN INFORMED OF THE POSSIBILITY OF SUCH DAMAGES OR (b) IS NEGLIGENT.

22. INSURANCE

A. Licensee shall obtain and maintain, in full force and effect at all times, during operations covered by this Agreement, such minimum insurance as will cover the obligations and liabilities of Licensee, its agents, and its employees which may arise from the operations under this Agreement. Insurance shall have limits of not less than Commercial General Liability policy of minimum limits of:

General Aggregate	\$ 2,000,000 per policy period
Products/Completed Operations Aggregate	\$ 2,000,000 per policy period
Personal Injury/Advertising	\$ 2,000,000 per occurrence
Each Occurrence	\$ 2,000,000 per occurrence
Fire Legal Liability	\$ 50,000 any one fire

B. The policy will be endorsed to show the above aggregate limits applying to "each" job site or, as an alternative, the General Aggregate will be increased to \$4,000,000 per policy period. Policy will also specifically state the coverage applies to all operations conducted by the Licensee, its employees, or agents on behalf of Licensee or subsidiary.

C. Where the performance of the work involves structural property, underground property, or blasting, Licensee's Commercial General Liability insurance policy shall provide coverage to the insured for legal liability arising from operations under this Agreement for property damage:

1. arising out of blasting,
2. arising out of collapse of, or structural injury to, any building or structure or
3. To underground facilities and utilities.

D. Other general liability forms are acceptable in lieu of the Commercial General Liability Form however they are not to be used without written approval from Licensor.

1. Business Automobile Liability policy with minimum limits of:

Bodily Injury	\$2,000,000 per accident
Property Damage	\$ 2,000,000 per accident

as set forth in Exhibit E as may be updated in writing by the parties from time to time in accordance with method set forth under this Section 23.

24. CONFIDENTIALITY

Neither party shall at any time disclose, provide, demonstrate or otherwise make available to any third party any of the terms or conditions of this Agreement or any materials provided by either party specifically marked as confidential, except upon written consent of the other party, or as may be required by applicable law or governmental authorities. Notwithstanding the foregoing, nothing in this Section shall prevent disclosure to a party's authorized legal counsel who shall be subject to this confidentiality section or to third parties as necessary to perform work under this Agreement provided that such third parties are bound by similar confidentiality provisions, nor shall it preclude the use of this Agreement by the parties to obtain financing, to make or report matters related to this Agreement in any securities statements, or to respond to any requests by governmental or judicial authorities; provided, however, that any such disclosure shall be limited to the extent necessary, and shall be made only after attempting to obtain confidentiality assurances. Notwithstanding the foregoing, prior to making any disclosure in response to a request of a governmental authority or legal process, the party called upon to make such disclosure shall provide notice to the other party of such proposed disclosure sufficient to provide the other with an opportunity to timely object to such disclosure. Notwithstanding the foregoing, Licensor may, without notice to Licensee: (i) negotiate or enter into any agreement with any other person(s) or entity(ies) that is identical or similar to this Agreement; and (ii) provide the text of all or part of this Agreement to any other party, so long as Licensor shall redact therefrom all references to Licensee and shall not associate such text with Licensee or identify Licensee as having agreed to such text or terms.

25. DISPUTE RESOLUTION

A. Except in the case of:

1. a suit, action, or proceeding by one party to compel the other party to comply with its obligation to indemnify the other party pursuant to this Agreement, or
2. a suit, action or proceeding to compel either party to comply with the dispute resolution procedures set forth in this section, the parties agree to use the following procedure to resolve any dispute, controversy, or claim arising out of or relating to this Agreement or its breach.

B. At the written request of a party, each party shall designate a knowledgeable, responsible representative to meet and negotiate in good faith to resolve any dispute, controversy, or claim arising under this Agreement. The parties intend that these negotiations be conducted by non-lawyer, business representatives. The substance of the negotiations shall be left to the discretion of the representatives. Upon mutual agreement, the representatives may utilize other alternative nonbinding dispute resolution procedures such as mediation to assist in the negotiations. Discussions and correspondence between the representatives for the purposes of these negotiations shall be treated as confidential, undertaken for purposes of settlement, shall be exempt from discovery and production, and shall not be admissible in any subsequent proceeding without the concurrence of all parties. Documents identified in or provided during such negotiations, which are not prepared for purposes of the negotiations, shall not be so exempt and may, if otherwise admissible, be admitted as evidence in any subsequent proceeding.

C. If a resolution of the dispute, controversy or claim is not reached within thirty (30) days of the initial written request referred to in this Section 25, the dispute, controversy, or claim may be filed with the State utility commission or the Federal Communication Commission, if applicable, for review and determination, provided the party invoking the commission's intervention process has in good faith negotiated, or attempted to negotiate, with the other party pursuant to this Section 25.

D. Except as otherwise provided in this Agreement under the Indemnification or Default provision or elsewhere, each party shall bear its own costs, including attorneys' fee, incurred in connection with any of the foregoing procedures.

26. TAXES

Each party shall pay all taxes and assessments lawfully levied on its own property and services subject to this Agreement.

27. WAIVER

Failure by either party to enforce or insist upon compliance with any of the terms or conditions of this Agreement shall not constitute a general waiver or relinquishment of any such terms or conditions, but the same shall be and remain at all times in full force and effect.

28. NO THIRD PARTY BENEFICIARIES

Except as otherwise provided in this Agreement, this Agreement is intended to benefit only the parties and may be enforced solely by the parties, their successors in interest or permitted assigns. It is not intended to, and shall not, create rights, remedies or benefits of any character whatsoever in favor of any persons, corporations, associations, or entities other than the parties, except as provided herein.

29. FORCE MAJEURE

Neither party shall be liable for any delay or failure in performance of any part of this License Agreement or License issued hereunder from any cause beyond its reasonable control and without its fault, omission or negligence, such as acts of God, acts of civil or military authority, embargoes, epidemics, war, terrorist acts, riots, insurrections, fires, explosions, earthquakes, nuclear accidents, floods, power blackouts, labor strikes, lockouts or work stoppages or severe weather ("Force Majeure Event"). In the event of a Force Majeure Event, upon giving prompt notice to the other party, the due date for performance by the affected party of its original obligation(s) shall be extended by a term equal to the time lost by reason of the Force Majeure Event. In the event that the affected party is able to partially perform its obligations, it shall perform its obligations at a performance level no less than that which it uses for its own operations.

30. ASSIGNMENT

Licensee shall not assign, transfer or sublet the privileges hereby granted, or sell, lease or otherwise permit the use of its facilities on or any part thereof (all of the foregoing being "Transfers"), without prior consent in writing of Licensor, which consent shall not be unreasonably conditioned, withheld or delayed. No such consent granted by Licensor shall be effective until Licensee's assignee, sublessee or other transferee has agreed, on an enforceable separate document signed and delivered to

Licensor, to assume all obligations and liabilities of Licensee under this Agreement. Licensor may condition such consent upon the assignee's sublessee's or transferee's agreement to reasonable additional or modified terms or conditions. Licensee may Transfer its rights and obligations under this Agreement without such consent to (a) any entity Licensee directly or indirectly controls, is controlled by or is under common control with or (b) any entity acquiring all or substantially all of Licensee's assets or equity, by providing written notice to Licensor of such Transfer. Licensor may assign or otherwise transfer this Agreement or any of its rights and interests to any firm, corporation or individual, without the prior consent of Licensee.

31. APPLICABLE LAW

This Agreement, and the rights and obligations contained in it, shall be governed and construed under the laws of the state in which the Attachments hereunder are to be located. The terms and conditions of this Agreement shall be subject to any and all applicable laws, rules, regulations or guidelines now in effect and that subsequently may be prescribed by any federal, state or local governmental authority. To the extent required by any such prescribed law, rule, regulation or guideline, the Parties agree to modify, in writing, the affected term(s) and conditions(s) of this Agreement to bring them into compliance with such law, rule, regulation or guideline. Should any term of this Agreement be determined by a court or agency with competent jurisdiction to be unenforceable, all other terms of this Agreement shall remain in full force and effect.

32. WAIVER OF JURY TRIAL

Licensor and Licensee each expressly waive its right to a jury trial.

33. ENTIRE AGREEMENT, MODIFICATIONS, SURVIVAL AND CONFLICTS AND TARIFFS

A. This Agreement cancels and supersedes all previous agreements whether written or oral, except for any sums due thereunder, between Licensor and Licensee with respect to the Licensee's Attachments to Licensor's Poles; and there are no other provisions, terms or conditions to this Agreement except as expressed herein. All currently effective Licenses and authorizations for Attachments granted pursuant to such previous agreements shall continue in effect subject to the terms and conditions of this Agreement.

B. This Agreement may be amended or supplemented at any time only upon written agreement by the parties hereto. Notwithstanding the foregoing, all Exhibits, fees, Licensor procedures and specifications may be modified by Licensor upon thirty (30) day written notice to Licensee.

C. Notwithstanding the termination of this Agreement for any reason, Section 18 Compliance with Laws, Assumption of Risk and Disclaimer of Warranties, Section 21 Indemnification and Limitation of Liability, Section 22 Insurance, Section 24 Confidentiality and any other provision intended to survive, shall survive termination to the maximum extent permitted under applicable law. Notwithstanding any provisions to the contrary, all rights, remedies, or obligations which arose or accrued prior to the termination or expiration of the terms hereof shall survive and be fully enforceable for the applicable statute of limitations period.

D. It is the intent of the parties that the terms and conditions of this Agreement and any applicable Licensor's state tariffs be construed as being consistent where possible. However, in the event of a

conflict or difference between the terms and conditions of this Agreement and Licensor's state tariff, the terms of the applicable state tariff shall control.

34. AUTHORITY AND COUNTERPARTS AND ELECTRONIC SIGNATURES

A. Each party represents and warrants that it is an entity duly organized, validly existing in the state of its organization and in good standing under the laws of the state in which the obligations under this License Agreement are to be performed. Each party warrants that it has full power and authority to execute and deliver this License Agreement and to perform its obligations hereunder.

B. This Agreement may be executed using facsimile or electronic signatures and such facsimile or electronic version of the Agreement shall have the same legally binding effect as an original paper version. This Agreement may be executed in counterparts, each of which shall be deemed an original.

LICENSOR

LICENSEE

Windstream Kentucky East, LLC

CMN-RUS, Inc.

BY:  _____
NAME: 3B94FD8090FA44F... Joyce Latham _____

BY: _____
NAME: _____

TITLE: Director OSP Engineering

TITLE: _____

DATE: 12/4/2018

DATE: _____

conflict or difference between the terms and conditions of this Agreement and Licensor's state tariff, the terms of the applicable state tariff shall control.

34. AUTHORITY AND COUNTERPARTS AND ELECTRONIC SIGNATURES

A. Each party represents and warrants that it is an entity duly organized, validly existing in the state of its organization and in good standing under the laws of the state in which the obligations under this License Agreement are to be performed. Each party warrants that it has full power and authority to execute and deliver this License Agreement and to perform its obligations hereunder.

B. This Agreement may be executed using facsimile or electronic signatures and such facsimile or electronic version of the Agreement shall have the same legally binding effect as an original paper version. This Agreement may be executed in counterparts, each of which shall be deemed an original.

LICENSOR

Windstream Kentucky East, LLC

BY: _____

NAME: _____

TITLE: _____

DATE: _____

LICENSEE

CMN-RUS, Inc.

BY:  _____

NAME: John Greenbank

TITLE: Executive Vice President

DATE: December 3, 2018

EXHIBIT A
DEFINITIONS

“Application for Pole License” - A written request submitted in the form of Exhibit B from Licensee to Licensor requesting authorization to attach Licensee owned facilities to Poles in accordance with this Agreement.

“Attachment(s)” – any facilities, cables or equipment attached to Poles or any other property owned or controlled by Licensor.

“Effective Date” - is the date this Agreement is last signed by the parties.

“Force Majeure Event” – shall have the meaning set forth in Section 29 of the Agreement.

“Hazardous Materials” -

Any substance, material or waste now or hereafter defined or characterized as hazardous, toxic or dangerous as defined by the Comprehensive Environmental Response, Compensation and Liability Act (“CERCLA”) of 1980, as amended, and other federal, state, and local health, safety, and environmental laws, ordinances, statutes, and rules, including but not limited to the Occupational Safety and Health Act (“OSHA”).

Any substance, material or waste now or hereafter classified as a contaminant or pollutant under any law, rules, ordinance, or authority.

Any other substance, material or waste, the manufacture, processing, distribution, use, treatment, storage, placement, disposal, removal or transportation of which is now or hereafter subject to regulation under any law, ordinance, statute, rule or regulation of any governmental body or authority.

“License” – is the specific nonexclusive and revocable permission from Licensor, in the form of a Licensor countersigned and returned Application for License, to Licensee authorizing Licensee to attach its facilities as applied for to Licensor Poles in accordance with this Agreement.

“Licensee Contractors” - shall have the meaning set forth in Section 10(D) of the Agreement.

“Make Ready Estimate” – is Licensor’s estimated cost to perform Make Ready Work on Licensor’s facilities on Poles to accommodate Licensee’s Attachment as requested in an Application for Pole License.

“Make Ready Work” - all Licensor, joint owner or other existing attacher work to prepare Licensor’s Poles and related facilities for the requested Attachment of Licensee’s facilities but not the actual placement of Attachments or administrative activities related to inquiries, verifications, requests or applications.

“Overlashing or overlashed” – lashing of an additional Licensee owned cable to Licensee’s own existing cable and/or strand attached to a Pole as set forth in Section 11 of this Agreement.

“Pole(s)” - a pole owned solely or jointly by Licensor or Poles owned by others to the extent that and for so long as Licensor has the right to permit others to be attached in the communications space.

“Pole Attachment Fee” - the fee paid annually per Attachment on a Pole. For billing purposes, a single Attachment includes the point of Attachment and all facilities located in the usable space on the Poles in the space assigned to Licensee (typically six inches above and six inches below the point of Attachment). If Licensee occupies more than one foot of usable space on Poles, separate Pole Attachment Fees shall apply to each one foot of space occupied.

“Right-of-Way” - right-of-way owned or controlled by Licensor.

“Unauthorized Attachment” – shall have the meaning set forth in Section 17(A) and 17(E) of the Agreement.

EXHIBIT B

FORM APPLICATION FOR POLE LICENSE

NOTE TO LICENSEE IF LICENSEE CHOOSES NOT TO PROCEED WITH THE APPLICATION - LICENSEE WILL BE BILLED FOR LICENSOR/WINDSTREAM'S ENGINEERING AND ADMINISTRATIVE TIME.

**EXHIBIT B
Windstream CORPORATION
APPLICATION FOR POLE LICENSE**

**PROPOSAL #:
Submit in Dupli**

Name of Firm/Licensee Applying: _____ Contact Name, Phone # _____
 Street Address, City, ST, ZIP of Firm Applying _____ EMAIL ADDRESS _____
 Licensee Authorized Signature & Date: _____



By this application & signature, Licensee agrees to pay all engineering and administrative fees associated with this application even if Licensee chooses NOT to proceed with the project. **ALL ESTIMATED Fees, including engineering & materials, MUST BE PAID IN FULL UP FRONT**
NON PAYMENT OF FEES WILL RESULT IN THIS APPLICATION AND ALL FUTURE APPLICATIONS BEING PLACED ON HOLD
NOTE: Final costs will be determined by actual time & material required to do the make-ready work. Any difference in charges will be billed accordingly.

Column 1	Column 2	Column 3	Column 4	Column 5	Column 6	Column 7	Column 8	Column 9	Column 10	Column 11	Column 12
Licensee to complete	Licensee to complete	Licensee to complete	Licensee to Complete	Licensee to Complete	Licensee to Complete	Licensee to Complete	Licensee to Complete	Licensee to Complete	Licensee to Complete	Windstream to Complete	Windstream To Complete
Windstream Lead & Structure No. (Pole No.)	Power Pole No.	Location: Street, City, Town, Zip Code	Height, Class, Ownership of Pole	Hgt of highest Tel Cable	Hgt of highest Tel Drop	Hgt of lowest Power Cable	Hgt of other attachments on pole	# & type of Attachments	Height of Licensee to attach	Licenseor Work Description	Bill for
1											
2											
3											
4											
5											
6											
7											
8											
9											
10											
11											
12											
13											
14											
15											
16											
17											
18											
19											
20											
21											
22											
23											
24											
25											

EXHIBIT B CONTINUED

ESTIMATED TOTAL COSTS
PLEASE ATTACH DRAWINGS TO THIS APPLICATION - IT WILL NOT BE PROCESSED WITHOUT THEM

Submit to: [Windstream .jointuse@windstream.com](mailto:Windstream_jointuse@windstream.com)

Acknowledged and Agreed to by Licensor: _____
 Name Title Date

Windstream Pole Attachment Data Sheet

EXHIBIT B – PART II

WINDSTREAM POLE NUMBER		POWER POLE NUMBER		
STREET LOCATION		NAME OF ATTACHER		
CITY/BORO/TOWNSHIP		DATE	FIELD PERSONNEL NAME	
ATTACHMENT TYPE <input type="checkbox"/> Cable <input type="checkbox"/> Power Supply <input type="checkbox"/> Service Drop <input type="checkbox"/> Overhead Guy				
POLE SIZE	TRANSFORMER/DEVICE ON POLE <input type="checkbox"/> Yes <input type="checkbox"/> No	STREET LIGHT <input type="checkbox"/> Yes <input type="checkbox"/> No	STREET LIGHT BRACKET HEIGHT	TOP OF CONDUIT RISER HEIGHT
GUYING REQUIRED FOR ANGLE, CORNER, OR TAP POLE CONSTRUCTION <input type="checkbox"/> Yes <input type="checkbox"/> No			CONDUIT RISER <input type="checkbox"/> Yes <input type="checkbox"/> No; If yes ⇒ <input type="checkbox"/> Primary <input type="checkbox"/> Secondary	

MAKE READY WORK	REQUIRED	IF YES, PROVIDE ADDITIONAL DETAIL
	<input type="checkbox"/> Yes <input type="checkbox"/> No	

POLE DRAWING	POLE NO. ⇒	BEFORE	AFTER	
	*TYPE OF POWER ATTACHMENT ⇒	<input type="checkbox"/> Neutral <input type="checkbox"/> Secondary		
	Company Name 1. _____ 2. _____ 3. _____ 4. _____			
				Mid Span Distance _____

SPAN	MID-SPAN HEIGHT Ft.	SPAN CROSSES OVER (Check all that apply)				
		<input type="checkbox"/> Body of Water	<input type="checkbox"/> Street	<input type="checkbox"/> Driveway	<input type="checkbox"/> Field	<input type="checkbox"/> Interstate
		<input type="checkbox"/> Swimming Pool	<input type="checkbox"/> Building	<input type="checkbox"/> Railroad	<input type="checkbox"/> Yard	<input type="checkbox"/> Parking Lot

NOTE	
-------------	--

EXHIBIT C

REMOVAL NOTICE AND LICENSE SURRENDER FORM

NOTIFICATION OF SURRENDER

Notification No. _____ **Date:** _____
City & State: _____

In accordance with the terms and conditions of the license agreement between us, dated _____, notice is hereby given that the License covering Attachments to the outside plant structures, as shown on the attached sketch, is surrendered.

Licensee: _____
Signature: _____
By (Print/Type): _____
Title: _____
Date: _____

Date Surrender Notice Received: _____

Licensor: _____
Signature: _____
By (Print/Type): _____
Title: _____
Date: _____

EXHIBIT D

SCHEDULE OF RATES, FEES AND CHARGES

Annual Attachment Rate (per Attachment)**	\$ [REDACTED]
Agreement Fee	\$ [REDACTED]
Application for Pole License Fee	\$ [REDACTED]
Unauthorized Attachment fee	\$ [REDACTED]

**** If Attachments are in a non-tariffed state, the rental rate is subject to annual adjustment based on FCC Calculation.**

EXHIBIT E

NOTICES CONTACT INFORMATION

IF TO LICENSOR

Email: windstream.poles@windstream.com

Windstream Kentucky East, LLC

PO Box 25410

Little Rock, AR 72221

IF TO LICENSEE:

ENGINEERING CONTACT FOR LICENSEE

Company Name	CMN-RUS, Inc.
Name of Responsible Party	Nicole Sugg
Address	3701 Communications Way Evansville, IN 47715
Phone	812.213.1365
Fax	N/A
Email	Permits@metronetinc.com

INVOICING / BILLING CONTACT FOR LICENSEE

Name	Cynthia Stevenson Sherri Van Fossen
Address	8837 Bond Street Overland Park, KS 66214
Phone	812.213.1080
Fax	N/A
Email	ap@qservicesco.com

**FIRST AMENDMENT
TO POLE ATTACHMENT LICENSE AGREEMENT**

THIS FIRST AMENDMENT TO POLE ATTACHMENT LICENSE AGREEMENT (the "First Amendment") is made and entered into as of December 1, 2018, to the Pole Attachment License Agreement by and between CMN-RUS, Inc., hereinafter referred to as "Licensee", and Windstream Kentucky East, LLC, hereinafter referred to as "Licensor", dated as of the 1st day of December, 2018 (the "PAA"). Licensee and Licensor may be referred to hereinafter, individually, as a "Party" or, collectively, as the "Parties".

WHEREAS, Licensee desires for Licensor to process pole attachment applications and perform make-ready work for a larger than usual number of attachments Licensee will be submitting in connection with work in the Lexington and Fayette County, Kentucky area (the "Lexington Project");

WHEREAS, Licensee and Licensor would like to amend Licensor's normal pole application and make-ready process to address the larger than usual number of attachments Licensee will be submitting in connection with the Lexington Project.

THEREFORE, for good and valuable consideration, the receipt and sufficiency of which are hereby acknowledged, Licensee and Licensor do hereby agree to the following terms and conditions.

1. The Parties agree that for purposes of the Lexington Project only, a new Section 8SUPP will be added to the PAA:

8SUPP. SIMPLIFIED ATTACHMENT REQUEST AND LICENSE PROCESS

A. Before Licensee shall have a right to place Attachments to any Poles of Licensor, Licensee shall apply in writing for, and receive, a revocable, non-exclusive License, which shall be in the form of a Licensor countersigned Application for Pole License (Exhibit B-1), before attaching its facilities to specified Licensor Poles. To apply for a License under this Section 8SUPP, Licensee shall submit to Licensor an Application which indicates that it is for Simple Make-Ready. Licensee shall provide sufficient information on the Application to enable Licensor to determine that the request involves only Simple Make-Ready, to locate the proposed Pole(s) impacted and to identify the physical characteristics of Licensee's facilities to be attached to Licensor's Poles so that Licensor can confirm that the attachments may be completed through Simple Make-Ready. Licensee shall not under any circumstances attach any equipment to any guy wires or anchors owned by Licensor. The process for attaching to Poles which will require Complex Make-Ready will continue to be governed by the terms contained in Section 8 of the Agreement.

B. Survey. For Poles requiring only Simple Make-Ready, Licensee shall send a notice (which may be via email or other electronic means) at least three (3) days in advance that Licensee will be surveying Licensor's Pole(s) with an Approved Contractor. After Licensee's survey has been completed, Licensee will submit an Application for Pole License in the form of Exhibit B-1 and shall include a drawing of the proposed route, the pole detail and Licensee's contact information (name, telephone, and email information). Licensee is responsible for determining, in accordance with requirements of the National Electric Safety Code, if the existing Licensor's facilities will support the additional loading imposed by the Licensee's attachments. Upon receipt of an Application, Licensor shall have ten (10) business days to review the Application to determine whether it is complete. If the Application is incomplete, Licensor will return the Application to Licensee along with an explanation detailing how it is deficient. For Applications that are complete, Licensor has thirty (30) days from receipt of the Application to

review and approve or reject the Application. If during this process, Licensor reasonably determines the request is denied because the work involves Complex Make-Ready or based on insufficient capacity or for reasons of safety, reliability and generally applicable engineering purpose, Licensor shall inform Licensee that the Application for Pole License is denied together with an explanation detailing why the Application was denied. Upon Licensor's approval of the Application or if such Application is not denied within thirty (30) days of receipt of the complete Application, Licensee will be considered to have been granted a License with respect to the Poles approved or deemed approved in the Application and may attach to Licensor's Poles in accordance with the terms and conditions of this Agreement. Licensee shall maintain a copy of all Applications for Pole Licenses and approved Licenses. Licensor may provide upon request copies of the same to the extent available and Licensee shall reimburse Licensor for its costs in preparing and sending requested copies.

C. Additional Resources. Licensor agrees that if Licensee utilizes the simplified process described in this Section 8SUPP, Licensor will process Applications for up to One Thousand (1,000) Poles per month, not to exceed Eight Hundred Fifty (850) Poles requiring Simple Make-Ready or One Hundred Fifty (150) Poles requiring Complex Make-Ready in a given month (the "Increased Pole Application Count"). The Parties agree that the Licensor may charge Licensee up to [REDACTED] (the "Processing Resource Charge") per month for the additional internal personnel necessary for Licensor to process the Increased Pole Application Count. Additionally, Licensee agrees that Licensor may pass through to Licensee the reasonable and actual costs incurred by Licensor, without mark-up, in connection with utilizing a third party for application and survey review (the "Application Review Charge"). The Parties agree further that the Processing Resource Charge and the Application Review Charge are in addition to the rates, charges and fees to be paid by Licensee pursuant to this Agreement. Licensor will have the resources in place necessary to process the Increased Pole Application Count by January 1, 2019. The Processing Resource Charge will be due and payable to Licensor on or before the first day of each month, starting with the month of January 2019. Licensee will be invoiced for the Application Review Charge in accordance with the terms of this Agreement. Licensor shall have no obligation to process the Increased Pole Application Count in connection with the Lexington Project in a given month until Licensee has paid the Processing Resource Charge for such month. Licensor shall have no obligation to process the Increased Pole Application Count in connection with the Lexington Project in a given month if Licensee is delinquent in its payment of the Processing Resource Charge. Licensee shall provide Licensor with written notice when it will no longer be submitting Applications for the Increased Pole Application Count in connection with the Lexington Project (the "Amendment Termination Notice"). Beginning upon the first day of the month following thirty (30) days from receipt of the Amendment Termination Notice, the First Amendment shall terminate, and Licensor shall have no obligation to process the Increased Pole Application Count. In the event Licensee declines to proceed with Simple Make-Ready for any given Pole(s) or Licensee's Application is denied and not resubmitted, Licensee shall still be responsible for the payment of the Application Fee and any Application Review Charge associated with such Application(s) or Pole(s).

D. Make-Ready. For Simple Make-Ready, Licensee will be responsible for coordinating with an Approved Contractor to attach to Licensor's Poles. As a part of the Simple Make-Ready, Licensee will be responsible for moving all existing Attachments, as may be necessary, to place Licensee's Attachments upon Licensor's Poles. Licensee will be responsible for all costs incurred by the Approved Contractor to place Licensee's Attachments and move any existing Attachments on Licensor's Poles. Licensee shall notify in writing all known other users that may be affected by the make-ready required for Licensee's attachments. The notice shall: (i) specify the location and type of make-ready to be performed; (ii) state Licensee will perform Simple Make-Ready within a set date for completion of all make-ready, which will be no sooner than

fifteen (15) days after Licensee's notice to the other users; and (iii) state that any entity with an existing attachment may modify the attachment consistent with the specified make-ready before the date set by Licensee for completion. All Simple Make-Ready work shall be performed in accordance with Licensor's specifications attached to this Agreement as Exhibit G and in accordance with the same standards and practices followed by Licensor or Licensor's contractors; provided however, with respect to materials to raise-lower-transfer set forth in Exhibit G, upon ten (10) days prior written notice to Licensor (which may be delivered via email or by other electronic means), Licensee may utilize other materials of the same type and equal or better quality. Authorized Contractors used by Licensee shall not conduct such work in any manner which degrades the integrity of Licensor's structures or interferes with any existing use of Licensor's facilities or the facilities of any other user. Once Simple Make-Ready is completed by an Authorized Contractor, Licensee shall notify Licensor. To the extent necessary, Licensee shall make arrangements with other users regarding reimbursement for any expenses incurred by other users in transferring or rearranging other users' facilities to accommodate the attachment or placement of Licensee's Attachments to or in Licensor's Poles. To the extent necessary, Licensee shall be solely responsible for negotiating with existing attachers concerning Simple Make-Ready relating to such other existing Attachments located on, within or in Licensor's Poles and shall be responsible for paying all charges incurred in transferring or rearranging existing Attachments to accommodate the placement of Licensee's Attachment on, within or in Licensor's Poles other than charges associated with fixing violations of existing attachers.

E. Indemnification. In connection with Simple Make-Ready, Licensee shall defend, indemnify, protect and hold harmless Licensor's officers, directors, employees, shareholders, successors, assigns, agents, affiliates, representatives, partners, and contractors from and against any and all claims, actions, administrative proceedings (including, without limitation, informal proceedings), judgments, damages, penalties, fines, cost, liabilities, interests, or loss, together with all other reasonable and actual costs and expenses for destruction of tangible property or personal injury, including death, or breach of contract suffered by or asserted against Licensor in any way directly arising out of activities undertaken pursuant to this Amendment by Licensee (including, without limitation, the installation, construction, operation or maintenance of Licensee's Attachments or work performed on other Attachments on Licensor's Poles, except to the extent caused solely by the negligence or willful misconduct of Licensor or its affiliates, agents, officers, employees and assigns). Licensee expressly assumes all liability for actions by its affiliates, agents, officers, employees, or contractors. The indemnification provisions set forth in this Section 1.E shall be subject to the processes and limitations of liability set forth in the Agreement.

F. Insurance. In addition to the insurance coverage required by this Agreement, the General Aggregate coverage provided by Licensee will be increased to \$4,000,000 per policy period so long as this Amendment is in effect.

2. The following Definitions will be added to Exhibit A of the Agreement:

"Approved Contractor" - A contractor approved by Licensor and listed on Exhibit F of the Agreement. Exhibit F may be amended from time to time upon the mutual agreement of Licensee and Licensor; provided however, such agreement shall not be unreasonably withheld or conditioned by Licensor and if Licensor has not objected to a contractor within ten (10) days of Licensee written request (which may be via email or other electronic means) for Licensor's agreement to add the contractor, such contractor shall be deemed an "Approved Contractor" provided such contractor meets the Contractor Minimum Qualification Requirements set forth in 47 CFR 1.1412(c) as amended by the Third Report and Order and Declaratory Ruling (FCC 18-111) released on August 3, 2018. However, Licensor reserves the right to remove any contractor from the list of Approved

Contractors for violations of this Agreement or if Licensor reasonably determines that the contractor does not meet the Contractor Minimum Qualification Requirements.

“Complex Make-Ready” – Make-ready that will: (a) require splicing, or (b) require that a new pole to be set, or (c) require work that is reasonably anticipated to lead to or cause a service outage for Licensor or any existing attacher, or (d) require relocation of existing wireless attachments.

“Simple Make-Ready” – Make-ready that is not Complex Make-Ready. Licensor has the right to determine in its sole reasonable discretion whether make-ready is Complex Make-Ready or Simple Make-Ready.

- 3. The Application for Pole License attached hereto as Exhibit A shall become Exhibit B-1 of the PAA.
- 4. The Lexington Aerial Contractors list attached hereto as Exhibit B shall become Exhibit F of the PAA.
- 5. The specifications attached hereto as Exhibit C shall become Exhibit G of the PAA.
- 6. This First Amendment shall serve to expressly modify the PAA. All other clauses, conditions, terms and covenants contained in the PAA, to the extent not amended by this First Amendment, shall continue in full force and effect and be legally binding.

AGREED TO effective as of December 1, 2018.

CMN-RUS, INC.

By: _____
 Printed Name: _____
 Title: _____
 Date: _____

WINDSTREAM KENTUCKY EAST, LLC

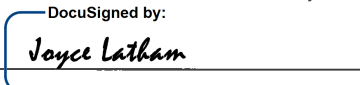
By:  _____
DocuSigned by:
Joyce Latham
3B94FD8090FA44F...
 Printed Name: Joyce Latham
 Title: Director OSP Engineering
 Date: 12/4/2018

AGREED TO effective as of December 1, 2018.

CMN-RUS, INC.

By:  _____

Printed Name: John Greenbank

Title: Executive Vice President

Date: December 3, 2018

WINDSTREAM KENTUCKY EAST, LLC

By: _____

Printed Name: _____

Title: _____

Date: _____

Exhibit A

**EXHIBIT B - WINDSTREAM COMMUNICATIONS
OTMR Application - Simple Make Ready**

Name of Firm Applying: _____

Contact Name,
Phone # _____

EMAIL ADDRESS _____

Street Address, City, ST, ZIP of Firm
Applying _____

Authorized Signature & Date: _____

By this application & authorized signature, my firm is agreeing to pay all fees associated with this application, even if my firm chooses NOT to proceed with the project.

	Column 1 Licensee to complete	Column 2 Licensee to complete	Column 3 Licensee to complete	Column 4 Licensee to Complete	Column 5 Licensee to Complete	Column 6 Licensee to Complete	Column 7 Licensee to Complete	Column 8 Licensee to Complete	Column 9 Licensee to Complete	Column 10 Windstream to Complete	Column 11 Windstream to Complete	Column 12 Additional Notes
	Windstream Lead & Structure No. (Pole No.)	Power Pole No.	Location: Street, City, Township, Zip Code	Height, Class, Ownership of Pole	Hgt of highest Tel Cable	Hgt of highest Tel Drop	Hgt of lowest Power Cable	Hgt of other attachmts on pole	# & type of Attachmts	Height Licensee to attach at	Bill for Rent Y or N	
1												
2												
3												
4												
5												
6												
7												
8												
9												
10												
11												
12												
13												
14												
15												
16												
17												
18												
19												
20												
21												
22												
23												
24												
25												

PLEASE ATTACH DRAWINGS AND POLE DATA SHEETS FOR EACH POLE LISTED TO THIS APPLICATION - IT WILL NOT BE PROCESSED WITHOUT THEM

Submit to: Windstream.JointUse@Windstream.com.

Windstream OSP Construction Manager/Engineer Authorized Signature & Date: _____

Exhibit B

Lexington Aerial Contractors List					
Contractor	Address	City	State	Zip	
Trinity Telecom LLC	3317 South Higley Road, Suites 114-412	Gilbert	AZ	85297	
Telecom Optics LLC	672 Snively Avenue	Eloise	FL	33880	
Fibernet Inc.	94 w Willis rd	Saline	MI	48176	
Bowlin Services, LLC	12200 Chandler Drive	Walton	KY	41904	
Hutchins Telecom Solutions, LLC	2010 Renaissance Boulevard	King of Prussia	PA	40601	

Exhibit C

AERIAL CONSTRUCTION SPECIFICATIONS

Overhead and Dead-End guys

- All guys shall be properly tensioned
- Maintain proper clearance
- Splicing of guys is not permitted
- All guys shall be bonded to the strand and MGN if present
- 3/8" Utility grade strand shall be used on all guys
- Guy guard to be placed on all down guys

Pole Attachment – (raise-lower-transfer)

- All pole-piercing holes will be 11/16"
- Minimum of 40" below power attachment
- No less than 12" separation between attachments
- No more than 1-1/2" or less than (2) full threads of bolt extending beyond the square nut
- Strand in a suspension clamp will always be below the through bolt
- Strand will be bonded to any other Windstream strand and grounded to the MGN
- If riser cables are to be adjusted refer to picture #3 – no kinks or sharp bends. Maintain proper bend radius.
- If spacers-bands – lashing wire termination is to be adjusted refer to pictures 5.1, 5.3, 5.4, 5.5, 5.6.
- 18' clearance over roadways must be maintained. IF EXISTING CLEARANCE IS 18' OR LESS ATTACHMENT(S) CANNOT BE LOWERED. This includes any 2-6 pr. service drops.
- Attachments over railroad crossings CANNOT be lowered without case-by-case approval from Windstream Engineering.
- Where transferring to a new pole and the old pole is completely vacated, the old pole must be removed.
- New poles involving power attachments cannot be attached to until power transfers are complete.

- Existing hardware may be reused if not damaged or deteriorated. Preform wraps and/or strand vises must NOT be reused.
- Work must be performed according to industry standards, OSHA, LFUCG, and Windstream regulations and safety requirements.
- If trimming is required, debris must be disposed of properly.

Materials to raise-lower -transfer

- | | | |
|-------------------------------|---------------------------|-------------------|
| • 5/8" machine bolts | Hubbell power systems | 8812, 8814, etc. |
| • 2 1/2" curved square washer | Hubbell | 6822 |
| • 5/8" square nut | Maclean Senior Industries | SI5365 |
| • 5/8" square nut | Hubbell | 55084P |
| • 3 bolt suspension clamp | Maclean | SII740 |
| • 3 bolt suspension clamp | Hubbell | 7903 |
| • 3 bolt curved susp. clamp | Maclean | SI1755 or 7902L |
| • 5/8" support strap | Maclean | SI0088A |
| • 1/2" X 4" lag screw | Hubbell | 508754 or J8754 |
| • 27" cable strap | Thomas and Betts | CSS270 |
| • 27" cable strap | Belden | DTD2725 |
| • Cable support spacer | Thomas and Betts | TCP360 |
| • Cable support spacer | Helleman Tyton | TAS120M |
| • D lashing wire clamp | Maclean | SI2175 |
| • D lashing wire clamp | Belden | 2609010 |
| • 5/8" guy hook | Maclean | SI4425 or P135AXW |
| • 3/8" utility grade strand | National Strand products | U10M5000 |
| • 3/8" utility grade strand | Preformed | GLS2107 |
| • 3/8" short bail strand vise | Maclean | 5102 |
| • 3/8" strand wraps | Maclean | DES1107 |
| • 3/8" strand wraps | Preformed | GDE1107 |
| • #6 Bare Copper Ground Wire | Republic Wire | 6awg |
| • Split Bolt Connector | Maclean | MAR4H |
| • Kuhl Clamp | Maclean | MARKUL |

SUSPENSION STRAND AND COPPER CABLE CAN BE EXTREMELY HEAVY AND/OR UNDER EXTREME PRESSURE, ESPECIALLY IN CORNERS AND DEAD-ENDS. PROPER EQUIPMENT AND METHODS MUST BE USED TO PREVENT PERSONAL INJURY, PROPERTY DAMAGE AND SAFETY RISKS TO THE PUBLIC.

U - LAISSE BUTTES, TROUSSEMENT

DIRECT BURIED CABLE W/ CABLE GUARDS

CABLE IN CONDUIT W/ CABLE GUARDS

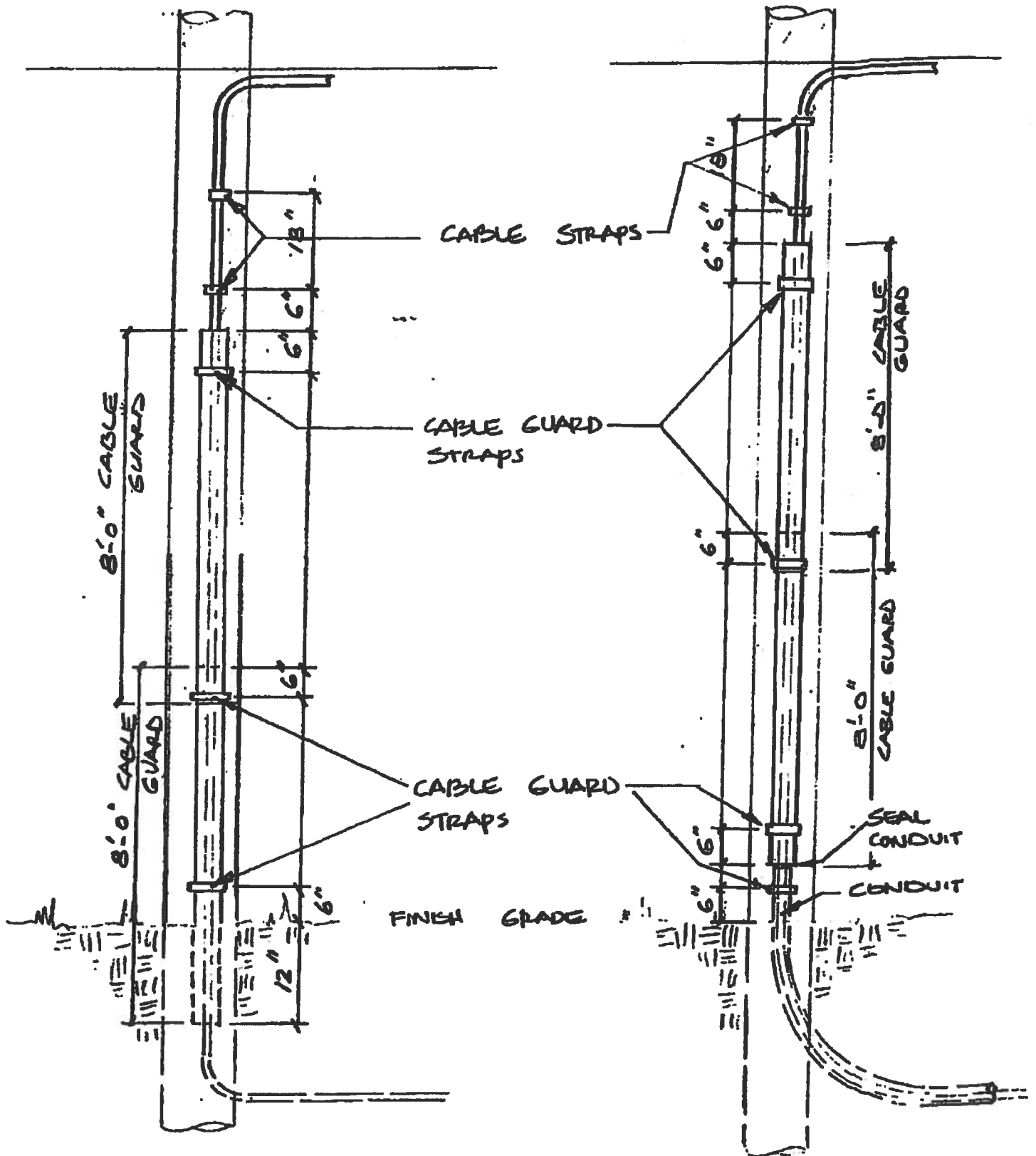

Picture # 3

PICTURE # 5.1

SPLICE CLOSURE - NO F.C. TERMINAL

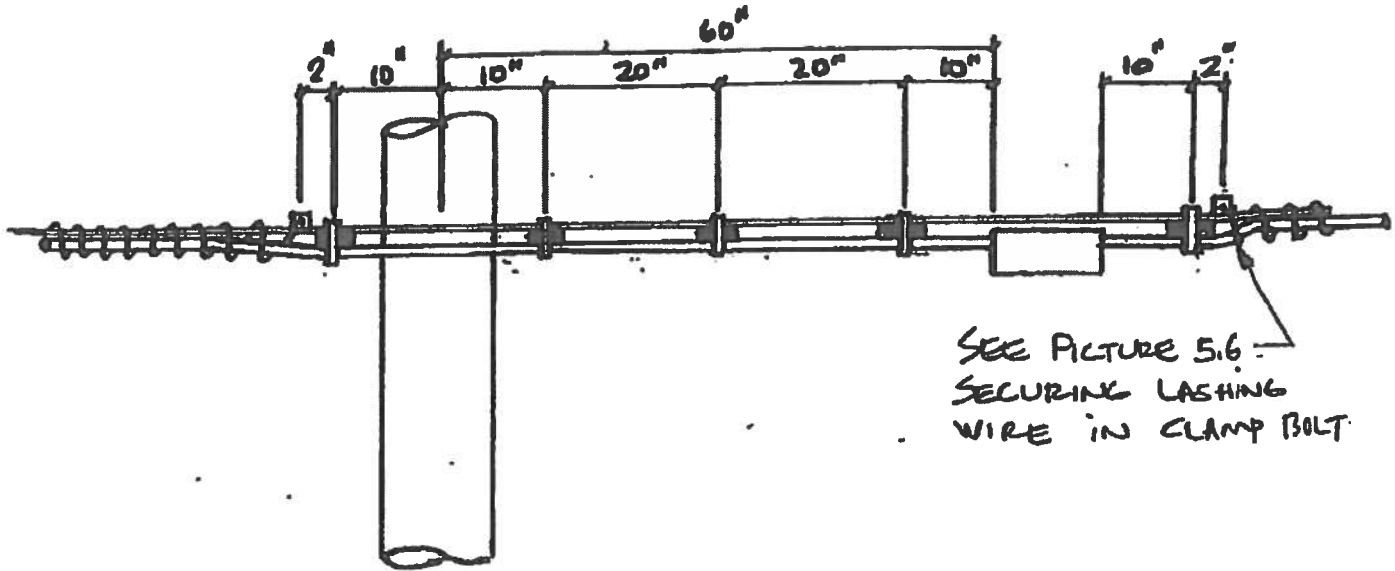

PICTURE # 5.2

MIDSPAN SPLICE CLOSURE

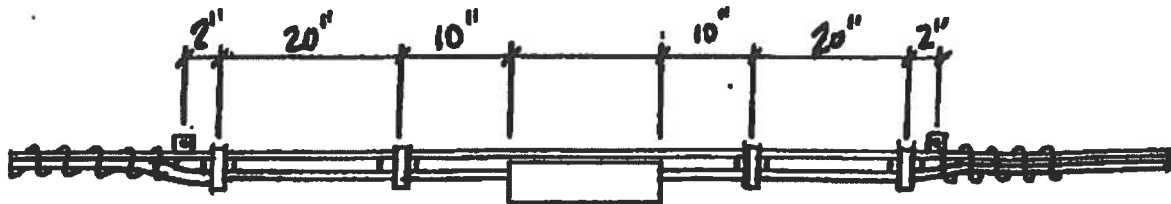

SEE PICTURE 5.6
SECURING LASHING
WIRE IN CLAMP BOLT

PICTURE # 5.3

CABLE SUPPORTS AND SPACERS
AT POLES - NO SPLICES

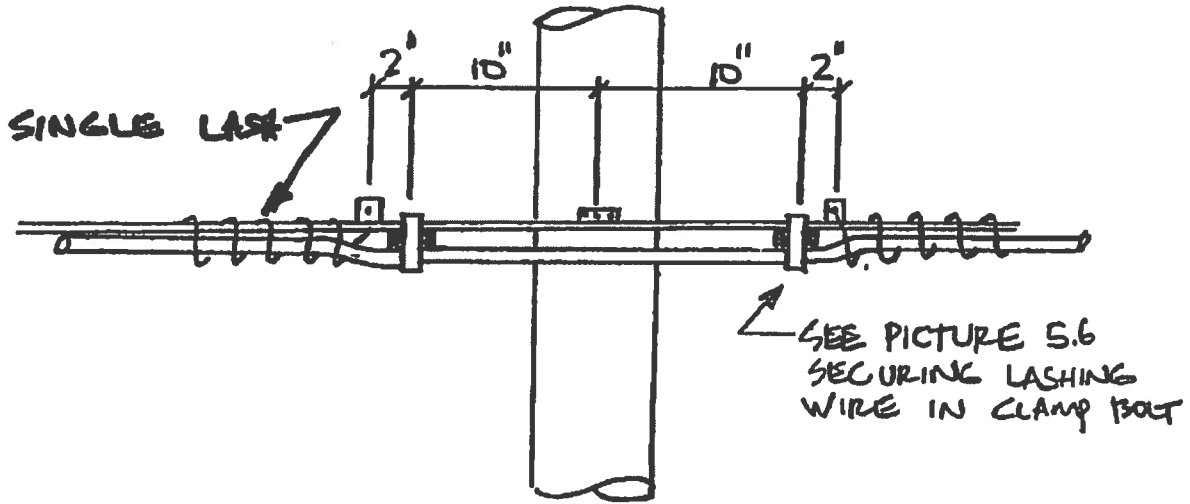

PICTURE # 5.4

CABLE SUPPORTS AND SPACERS
AT POLE - NO SPLICES - 1 OR 2
BUG NUT CONFIGURATION.

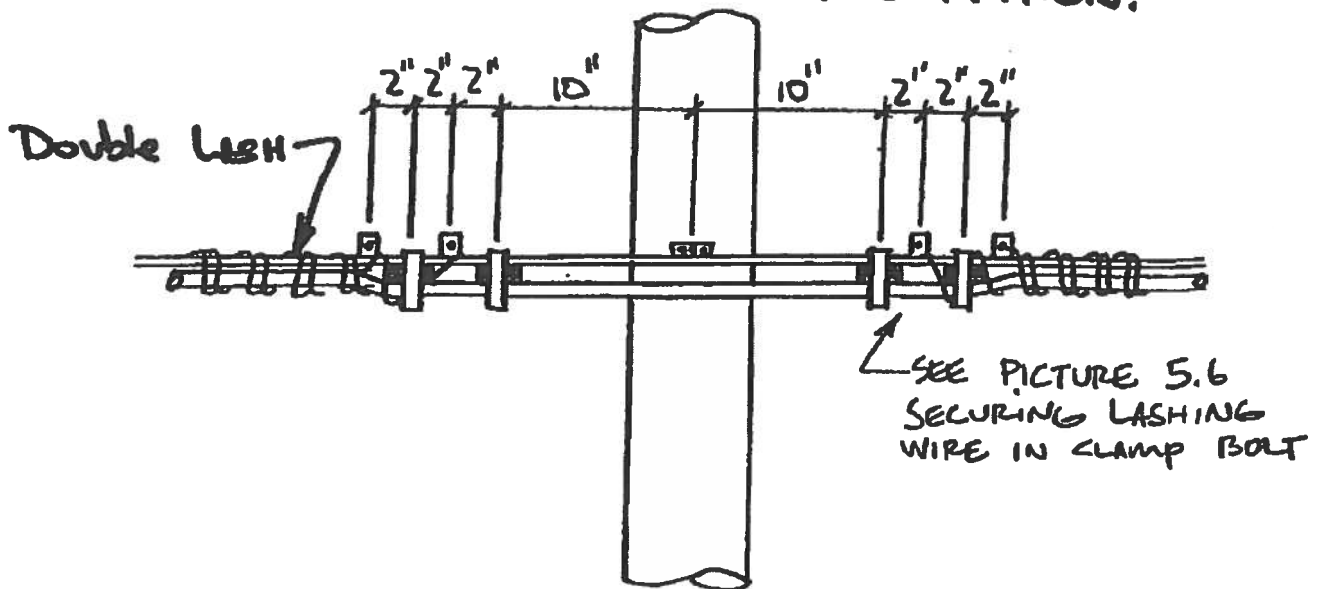

PICTURE 5.5

FIXED COUNT TERMINAL / SPLICE THROUGH CABLE

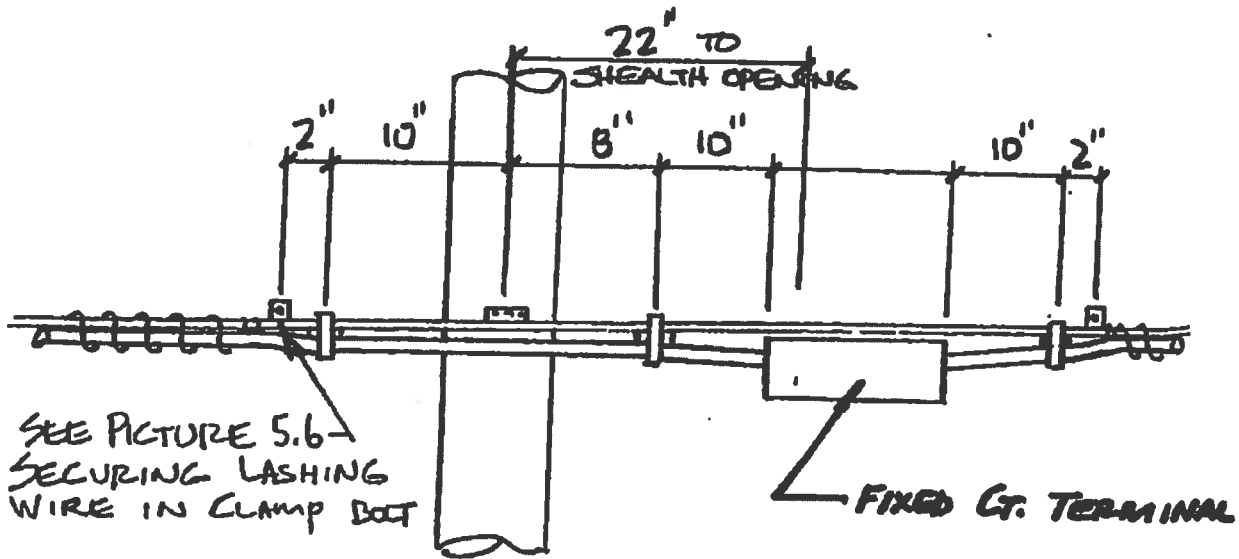

PICTURE 5.6

SECURING LASHING WIRE IN CLAMP BOLT

