

# gatorgrinder™

## General Applications

The Gatorgrinder reduces all forms of sanitary waste to a non-clogging slurry and pumps it through a network of small-diameter pipes. Since gravity is replaced by the power of the pump, sewer systems need not run downhill nor require large-diameter pipes, deep trenches, multiple lift stations – or their associated costs. Designed specifically for operation in warmer climates, the Gatorgrinder is an efficient, economic station for single dwelling service.

Automatic grinder pump activation is provided by the Gatorgrinder level control system. The Gatorgrinder is designed to run infrequently, for very short periods of time. The annual energy consumption is typically that of a 40-watt light bulb.

## Operational Information

### Motor

1 HP, 1,725 RPM, high torque, capacitor start, thermally protected, 120/240V, 60 Hz, single phase.

### Inlet Connection

4" inlet grommet standard for DWV pipe. Field penetration and installation of inlet grommet allows site plumbing flexibility.

### Discharge Connections

Tank is equipped with a factory installed discharge fitting. Tank discharge terminates in a 1-1/4" female NPT thread. Field connection of pump discharge to tank bulkhead is easily accomplished using the supplied discharge assembly or other material required by local code.

### Discharge\*

15 gpm at 0 psig  
11 gpm at 40 psig  
9 gpm at 60 psig

### Overload Capacity

The maximum pressure generated by the pump is limited by the motor characteristics and overload protection. The motor/pump combination generates a pressure well below the rating of the pipe and appurtenances. The automatic reset feature of the motor does not require manual operation following overload.

\*Discharge data includes minimal losses through the check valve.

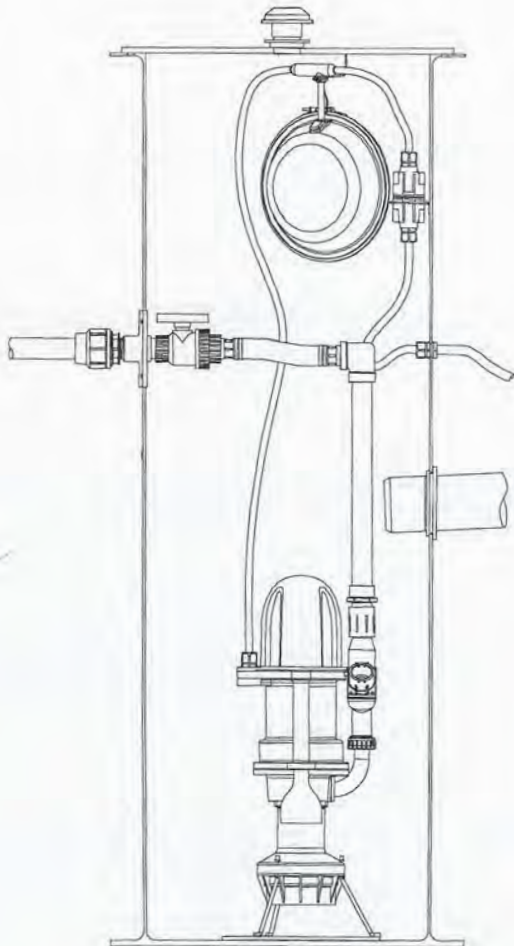

## Features

The Gatorgrinder is a complete unit that includes: the grinder pump, check valve, fiberglass tank and controls. The fiberglass tank is supplied complete with discharge fitting installed, simplifying installation of the grinder pump and plumbing.

All solids are ground into fine particles, allowing them to pass easily through the pump, check valve and small diameter pipelines. Even objects that are not normally disposed of through sewer lines, such as plastic, rubber, fiber, and wood, are ground into fine particles by the Gatorgrinder.

The 1-1/4" discharge fitting is adaptable to any piping material, thereby allowing us to meet your local code requirements.

The 24" diameter tank is constructed of laminated fiberglass and is available in several depths to accommodate capacity and site requirements. Other tank sizes are available upon request.

The integral grinder pump check valve assembly is custom designed for non-clog, trouble-free operation.

Patent Number(s): 5,439,180

Printed in USA, on recycled paper  
LM000171 Rev. B 5/01

# Gatorgrinder

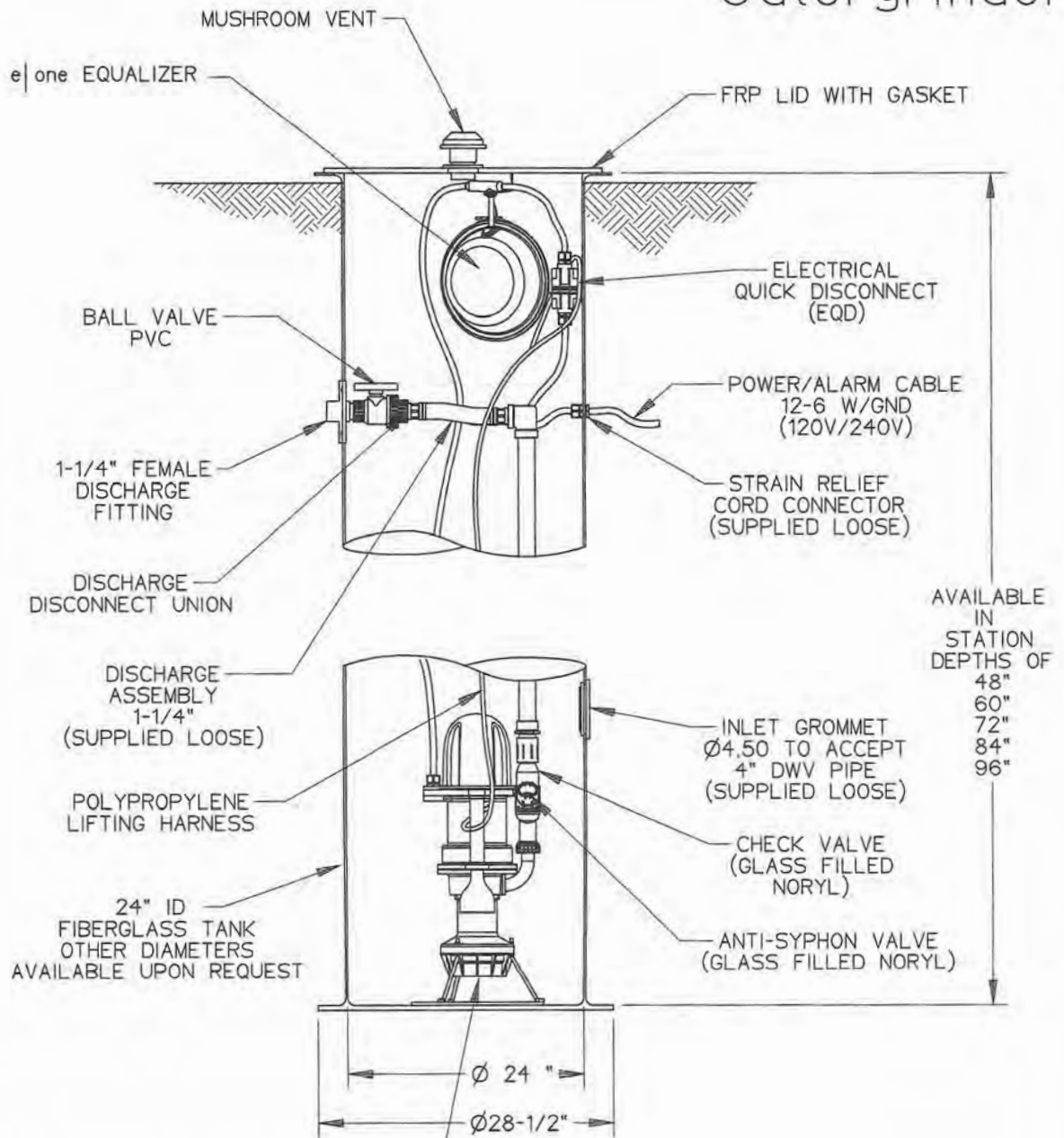

SEMI-POSITIVE DISPLACEMENT TYPE PUMP  
DIRECTLY DRIVEN BY 1 HP MOTOR  
CAPABLE OF DELIVERING 9 gpm AT 138' T.D.H.

NOTE:  
BALLASTING IS REQUIRED TO PREVENT  
TANK FROM FLOATING.  
INSTALL CONCRETE ANCHOR PER ENGINEERS RECOMMENDATIONS

SGS	PJD	5-24-01	B	1/16
DR BY	CHK'D	DATE	ISSUE	SCALE

## Gatorgrinder

DETAIL SHEET,  
GATORGRINDER STATION

LM000172

GG-2448

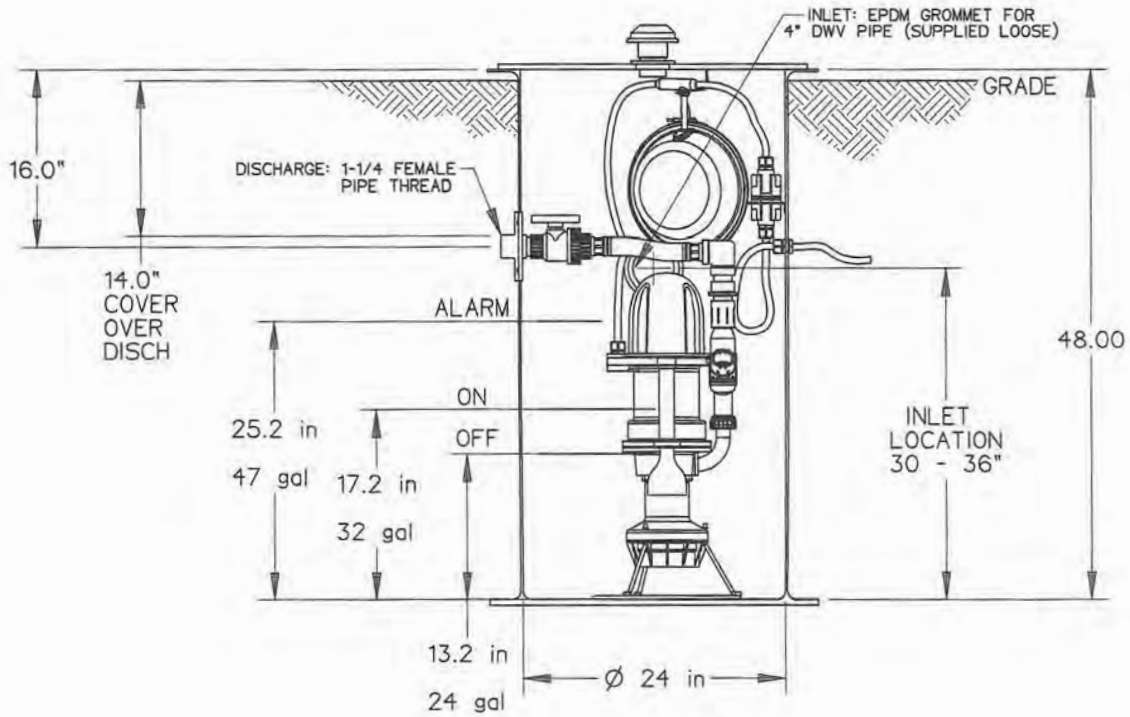

TANK BASE DETAIL

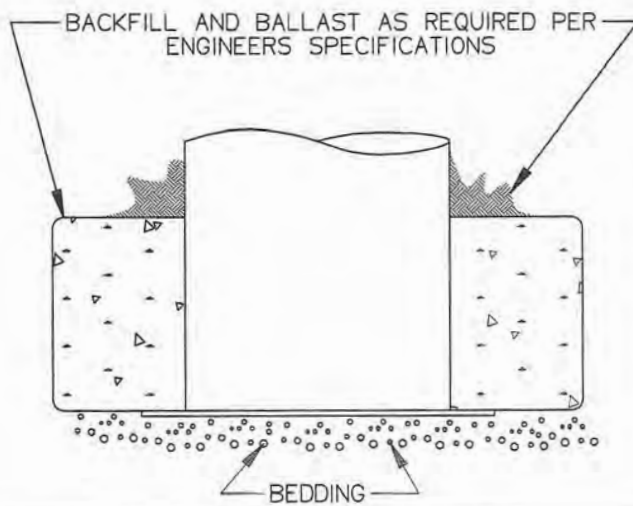

TANK VOLUME, LESS PUMP & DISCHARGE = 12.0cu ft/89.5 gal  
 TANK VOLUME (INTERNAL) = 12.5 cu ft/93.5 gal  
 TANK WEIGHT W/LID = 62 lbs

SGS	PJD	5-24-01	C	1/16
DR BY	CHK'D	DATE	ISSUE	SCALE
<b>Gatorgrinder</b>				
GATORGRINDER STATION 48"				
LM000177				



GG-2460

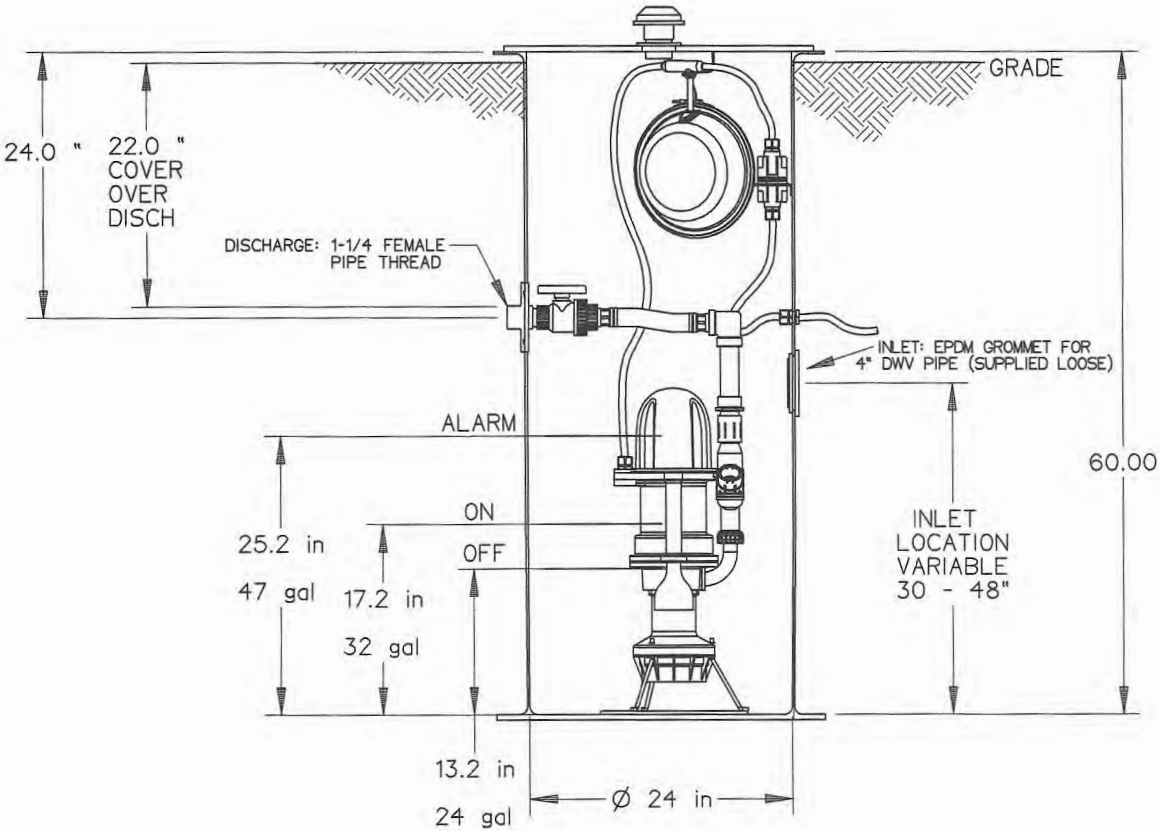

TANK BASE DETAIL

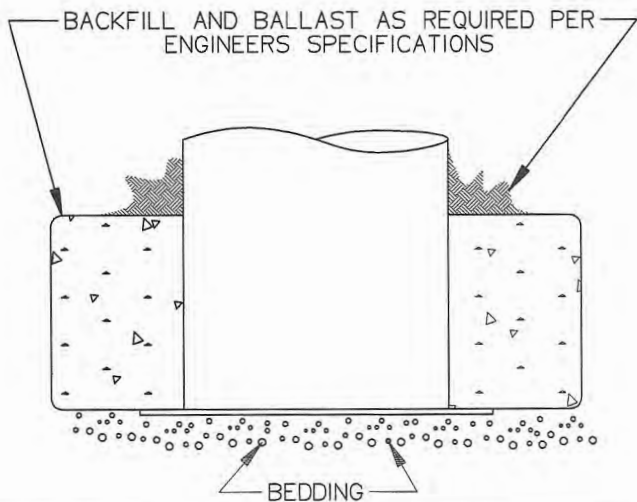

TANK VOLUME, LESS PUMP & DISCHARGE = 15.2cu ft/113.5 gal  
 TANK VOLUME (INTERNAL) = 15.7 cu ft/117.5 gal  
 TANK WEIGHT W/LID = 71 lbs

SGS	PJD	5-24-01	C	1/16
DR BY	CHK'D	DATE	ISSUE	SCALE
<b>Gatorgrinder</b>				
GATORGRINDER STATION 60"				
LM000173				

GG-2472

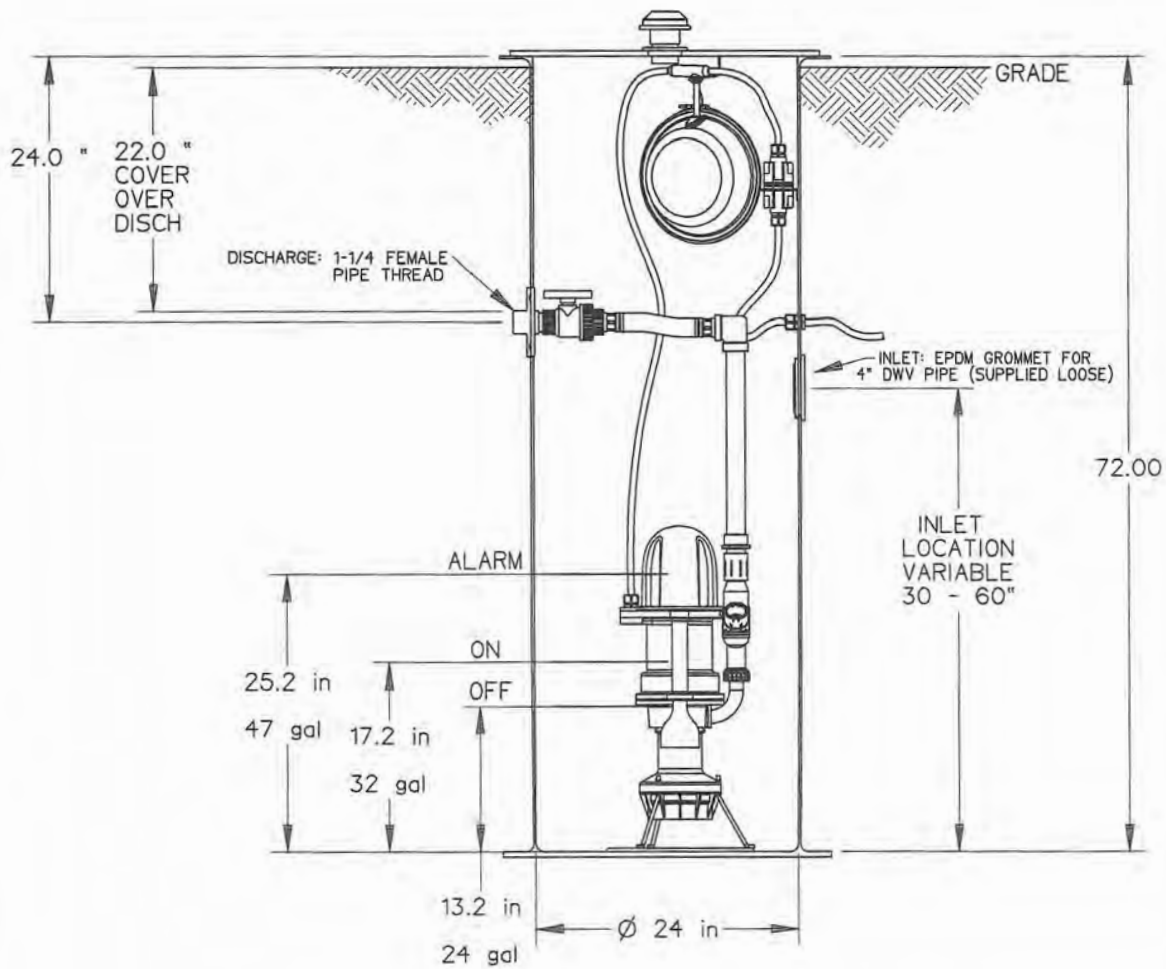

TANK BASE DETAIL

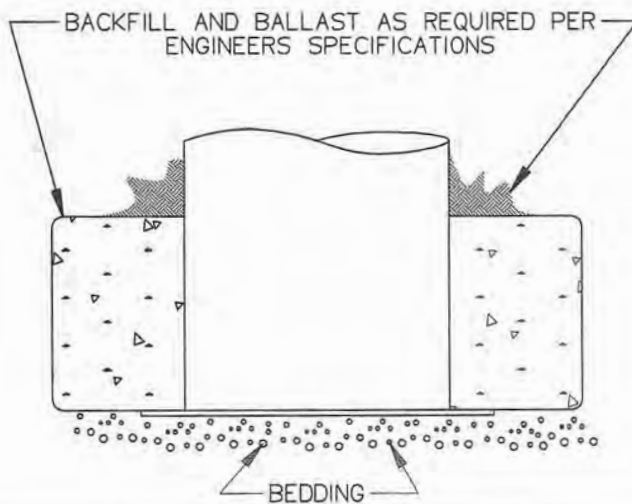

TANK VOLUME, LESS PUMP & DISCHARGE = 18.3cu ft/136.7 gal  
 TANK VOLUME (INTERNAL) = 18.8 cu ft/140.7 gal  
 TANK WEIGHT W/LID = 81 lbs

SGS	PJD	5-24-01	C	1/16
DR BY	CHK'D	DATE	ISSUE	SCALE
<b>Gatorgrinder</b>				
GATORGRINDER STATION 72"				
LM000174				

GG-2484

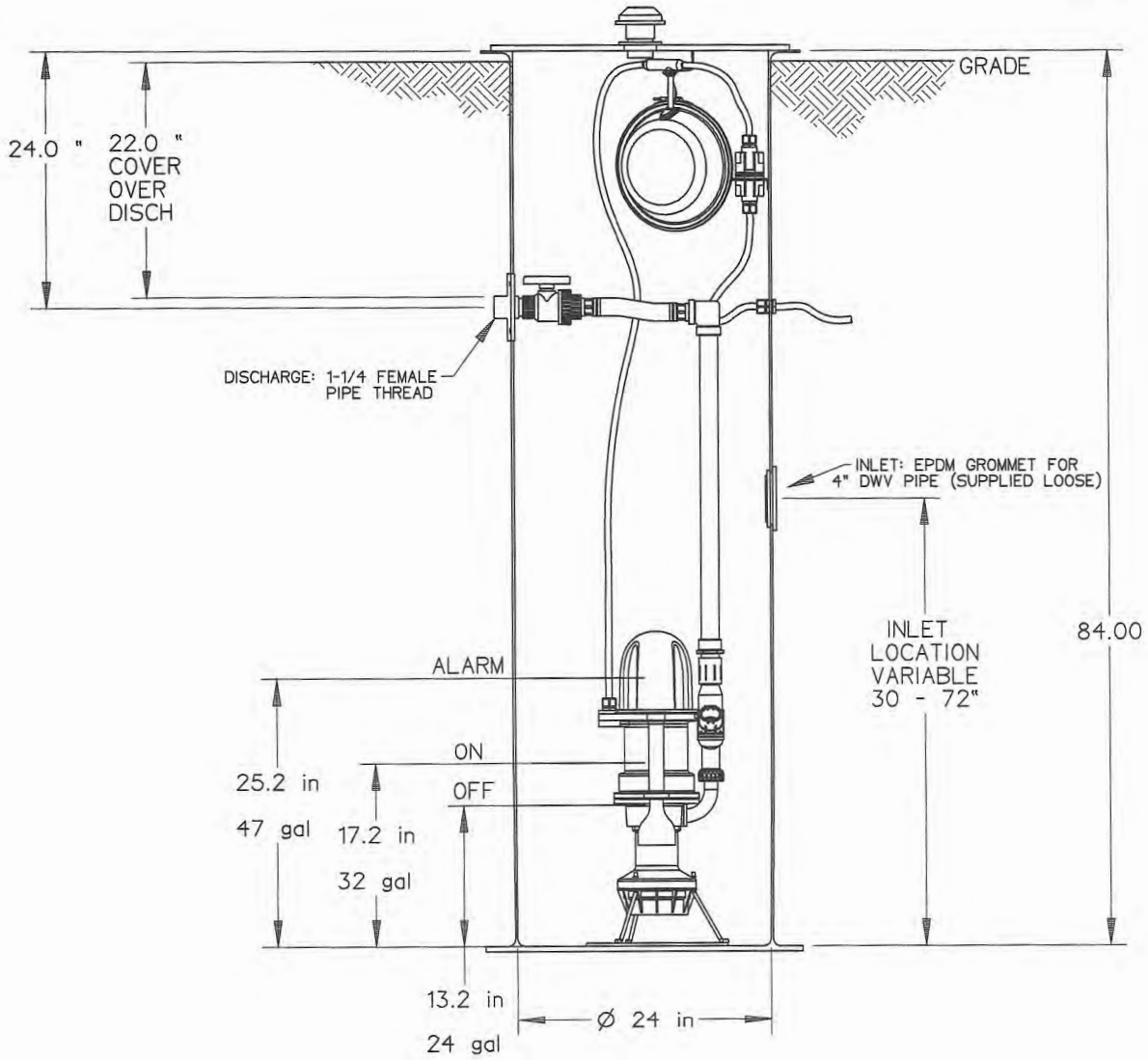

TANK BASE DETAIL

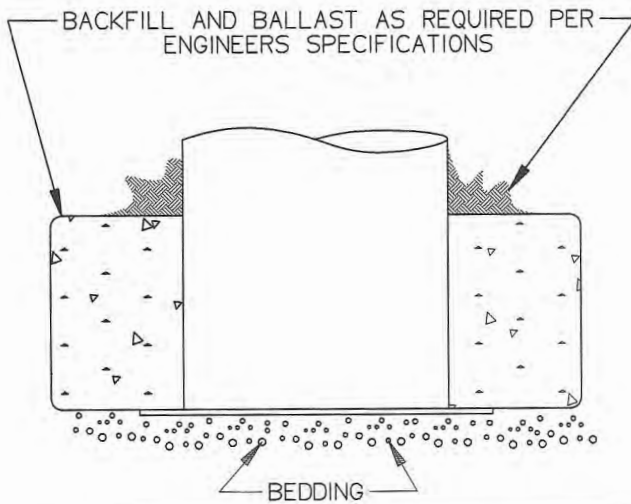

TANK VOLUME, LESS PUMP & DISCHARGE = 21.4cu ft/159.9 gal

TANK VOLUME (INTERNAL) = 21.9 cu ft/163.9 gal  
TANK WEIGHT W/LID = 90 lbs

SGS	PJD	5-24-01	C	1/16
DR BY	CHK'D	DATE	ISSUE	SCALE

**Gatorgrinder**

GATORGRINDER STATION  
84"

LM000175

GG-2496

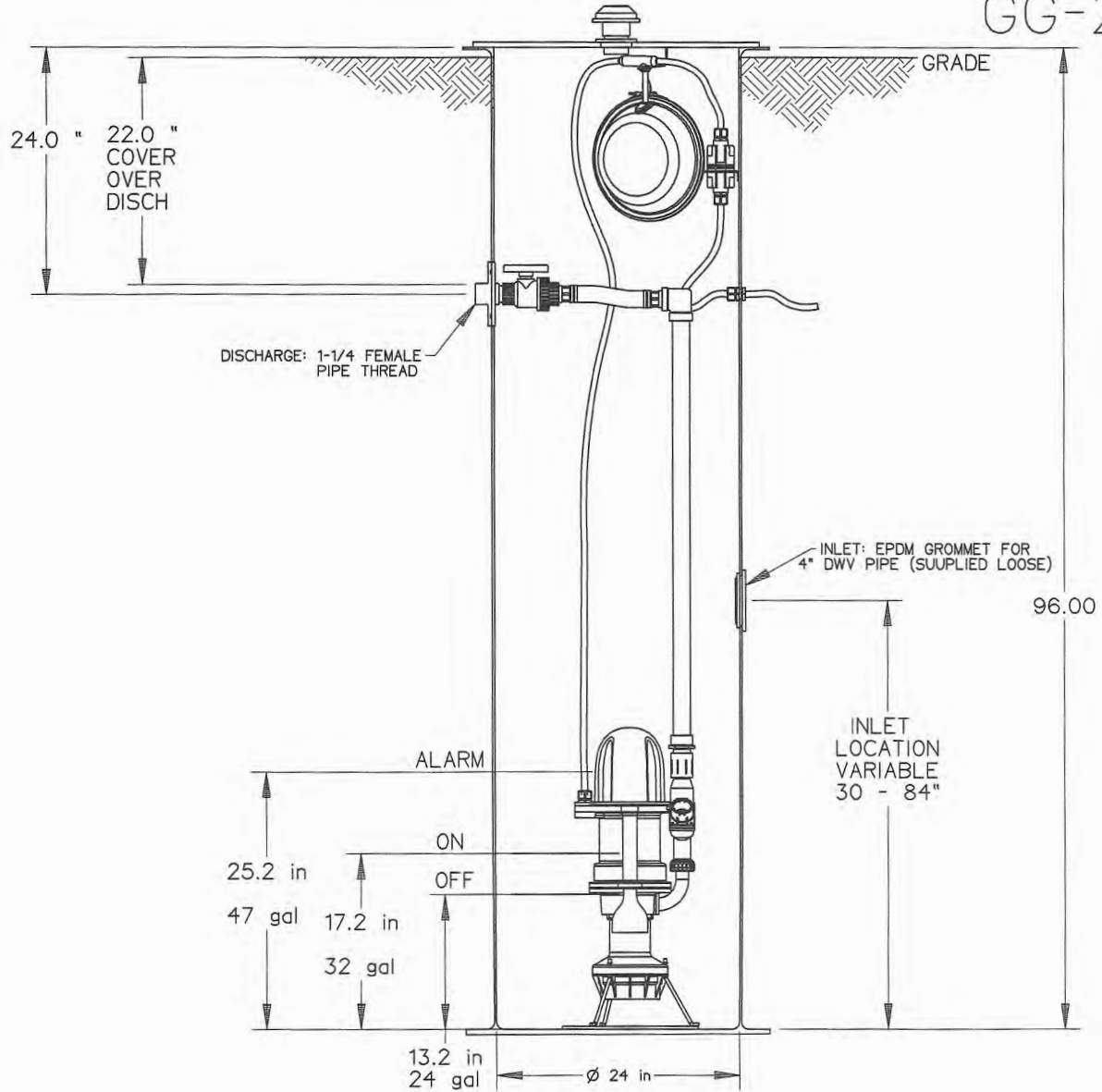

TANK BASE DETAIL

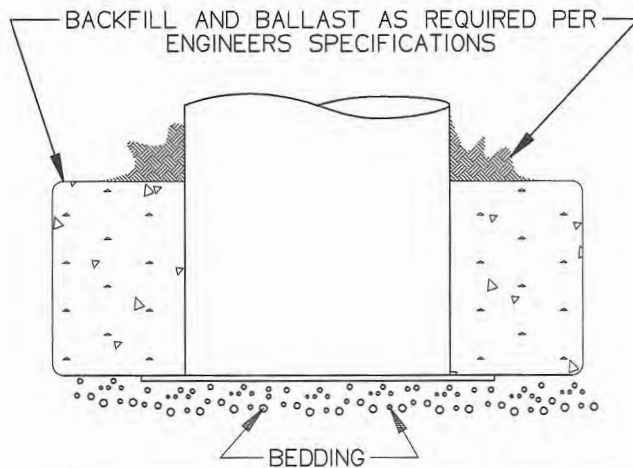

TANK VOLUME, LESS PUMP & DISCHARGE = 24.6cu ft/183.8 gal

TANK VOLUME (INTERNAL) = 25.1 cu ft/187.8 gal  
TANK WEIGHT W/LID = 99 lbs

SGS	PJD	5-24-01	C	1/16
DR BY	CHK'D	DATE	ISSUE	SCALE

**Gatorgrinder**

GATORGRINDER STATION  
96"

LM000176

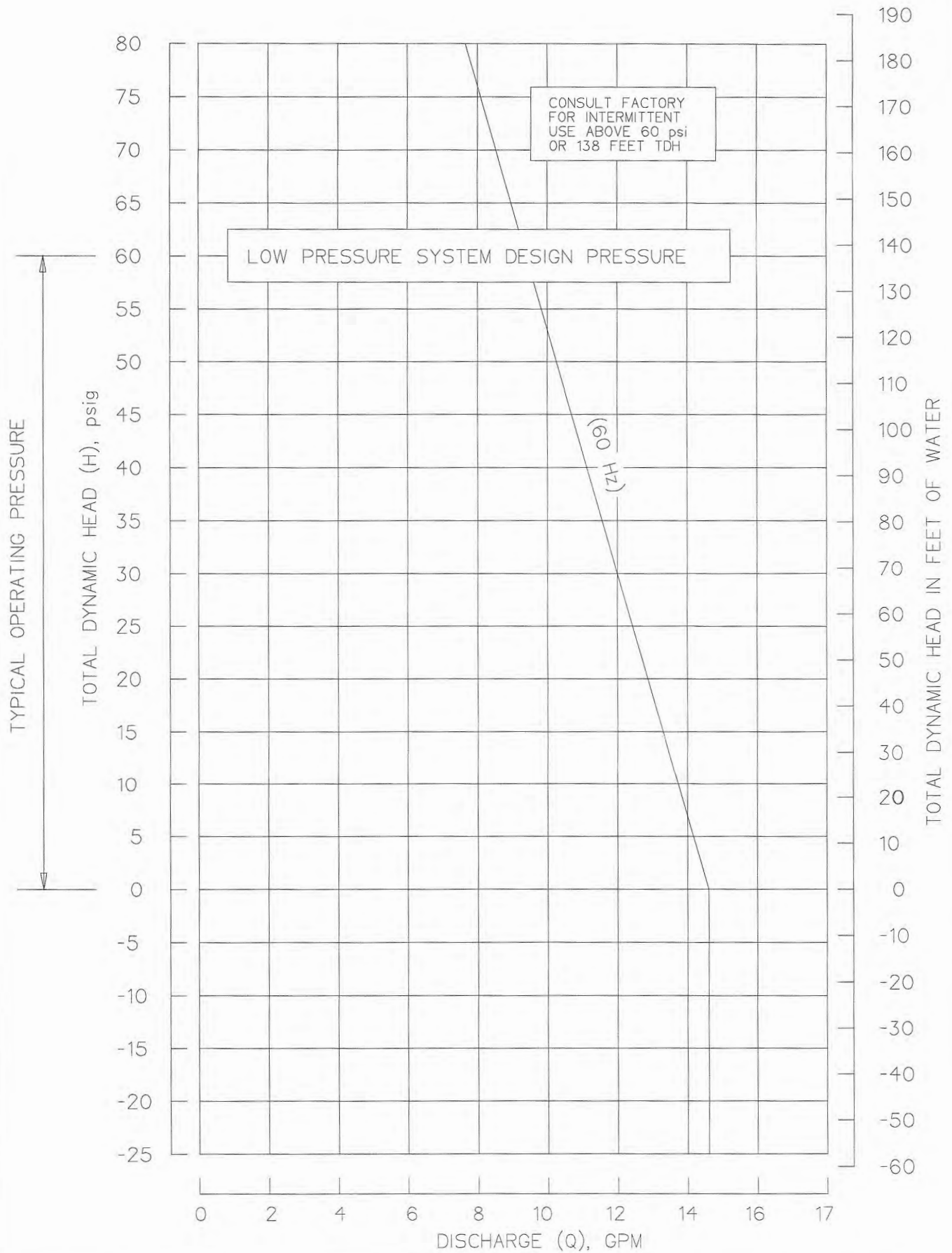

TYPICAL OPERATING PRESSURE

TOTAL DYNAMIC HEAD (H), psig

TOTAL DYNAMIC HEAD IN FEET OF WATER

DISCHARGE (Q), GPM

CONSULT FACTORY  
FOR INTERMITTENT  
USE ABOVE 60 psi  
OR 138 FEET TDH

LOW PRESSURE SYSTEM DESIGN PRESSURE

(60 Hz)



# W-Series Fiberglass

## General Features

W-Series fiberglass stations are available with one, two, three or four grinder pumps. Each station includes: the grinder pump(s), check valve, tank, controls, and alarm panel(s).

- Standard outdoor heights range from 60 inches to 144 inches
- Several tank diameters available; refer to the station drawings for specific sizes
- Flow ratings and tank capacities will vary with each tank size and number of grinder pumps; consult the factory for more information

The WH pump is the "hardwired," or "wired," model where a cable connects the motor controls to the level controls through watertight penetrations.

The WR pump is the "radio frequency identification" (RFID), or "wireless," model that uses wireless technology to communicate between the level controls and the motor controls.

## Operational Information

### *Motor*

1 hp, 1,725 rpm, high torque, capacitor start, thermally protected, 120/240V, 60 Hz, 1 phase

### *Inlet Connections*

4-inch and 6-inch EPDM grommets for DWV or DR35 pipe

### *Discharge Connections*

Pump discharge terminates in 1.25-inch NPT female thread. Can easily be adapted to 1.25-inch PVC pipe or any other material required by local codes.

### *Discharge*

15 gpm at 0 psig (0.95 lps at 0 m)  
11 gpm at 40 psig (0.69 lps at 28 m)  
7.8 gpm at 80 psig (0.49 lps at 56 m)

## Accessories

E/One requires that the Uni-Lateral, E/One's own stainless steel check valve, be installed between the grinder pump station and the street main for added protection against backflow.

Alarm panels are available with a variety of options, from basic monitoring to advanced notice of service requirements.

The Remote Sentry is ideal for installations where the alarm panel may be hidden from view.

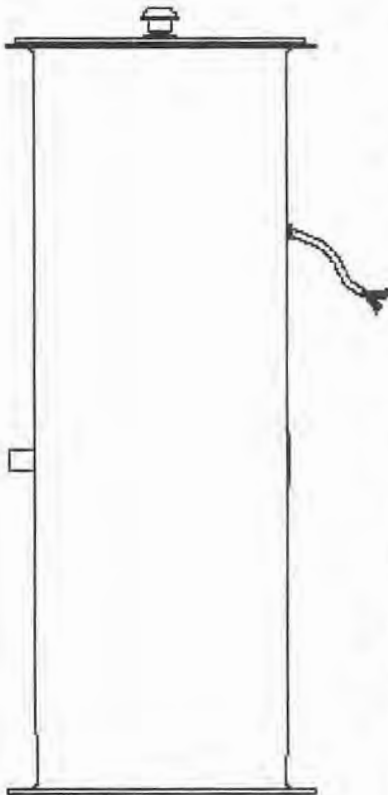

Patent Numbers: 5,752,315  
5,562,254 5,439,180

STATION TO BE USED WITH  
(2) MOD T260 DUPLEX PANELS

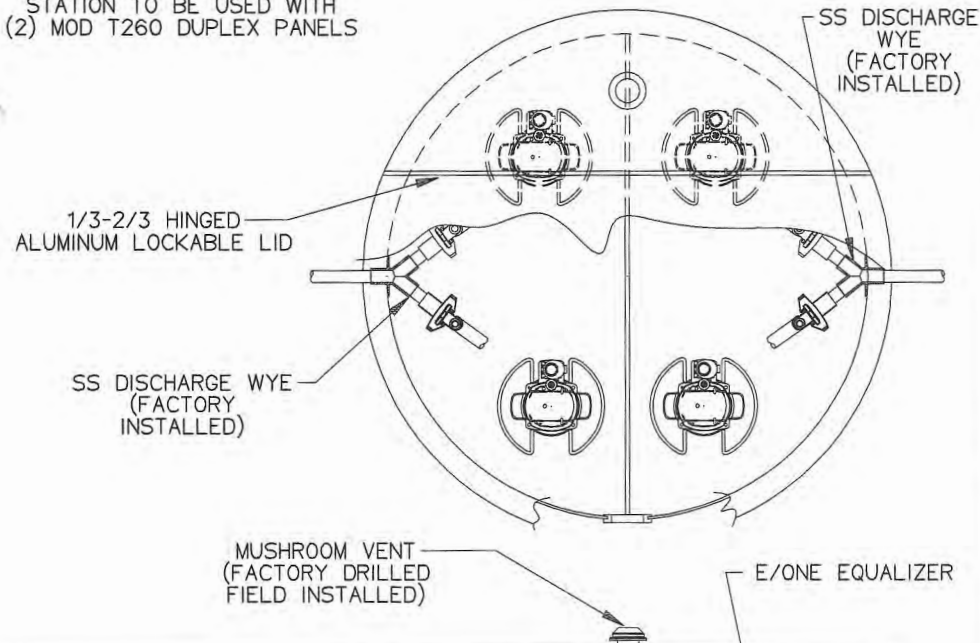

DIAMETER CHOICES

"D"  
60   
72

W SERIES  
QUADPLEX  
STATIONS

HEIGHT CHOICES

"H"	COD RANGE	
60	( 24 )	<input type="checkbox"/>
66	(24-30)	<input type="checkbox"/>
72	(24-36)	<input type="checkbox"/>
78	(24-42)	<input type="checkbox"/>
84	(24-48)	<input type="checkbox"/>
90	(24-54)	<input type="checkbox"/>
96	(24-60)	<input type="checkbox"/>
102	(24-66)	<input type="checkbox"/>
108	(24-72)	<input type="checkbox"/>
114	(24-78)	<input type="checkbox"/>
120	(24-84)	<input type="checkbox"/>
126	(24-90)	<input type="checkbox"/>
132	(24-96)	<input type="checkbox"/>
138	(24-102)	<input type="checkbox"/>
144	(24-108)	<input type="checkbox"/>

COVER OVER  
DISCH CHOICES

"COD"	
24	<input type="checkbox"/>
30	<input type="checkbox"/>
36	<input type="checkbox"/>
42	<input type="checkbox"/>
48	<input type="checkbox"/>
54	<input type="checkbox"/>
60	<input type="checkbox"/>
66	<input type="checkbox"/>
72	<input type="checkbox"/>
78	<input type="checkbox"/>
84	<input type="checkbox"/>
90	<input type="checkbox"/>
96	<input type="checkbox"/>
102	<input type="checkbox"/>
108	<input type="checkbox"/>

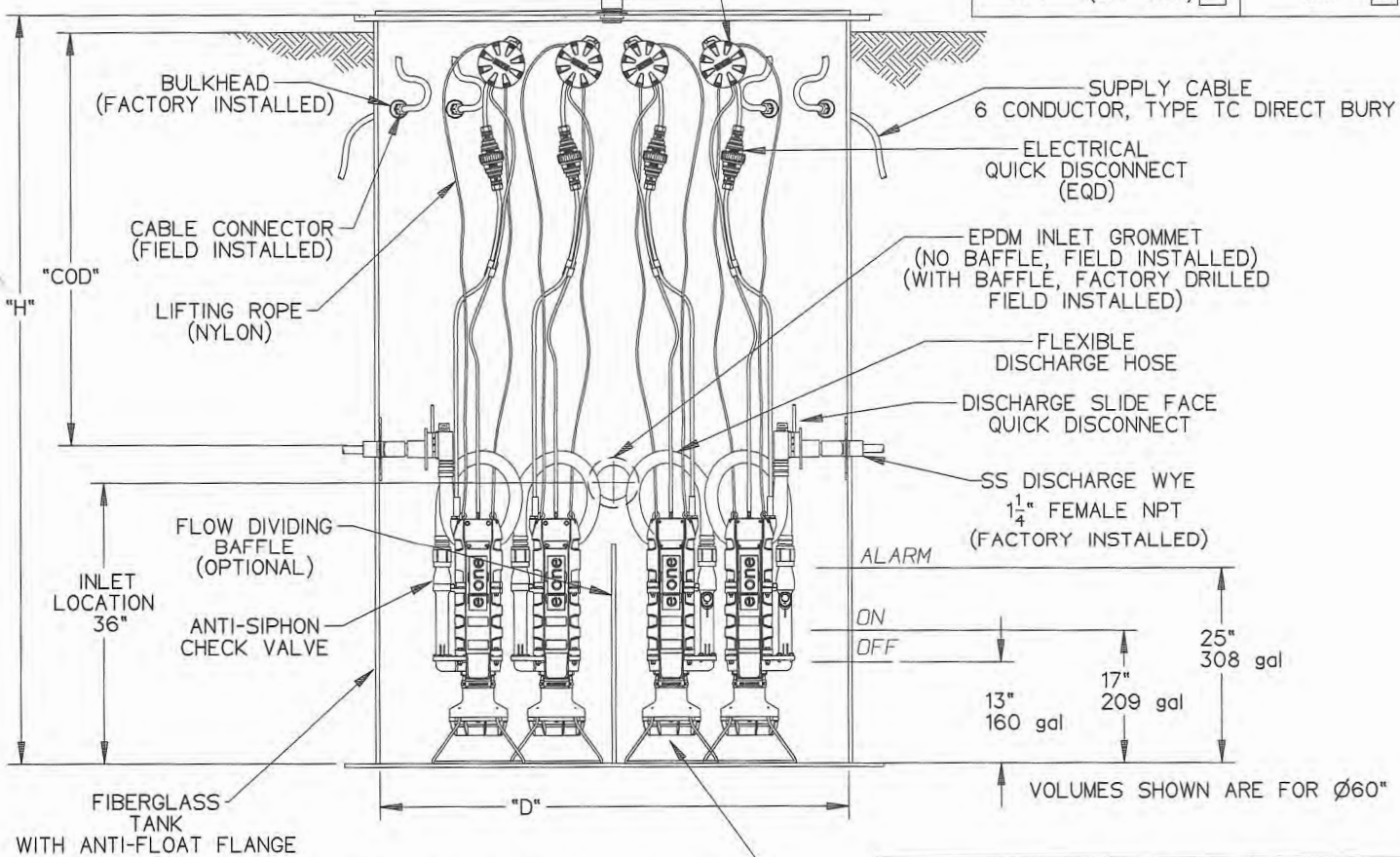

FOUR SEMI-POSITIVE DISPLACEMENT TYPE PUMP  
DIRECTLY DRIVEN BY 1 HP MOTOR

NOTE:

- 4" & 6" INLETS ARE EPDM GROMMETS
- 8" DWV INLET IS A CAST IRON CAULKING HUB
- 8" DR35 INLET IS A CAST IRON CAULKING HUB AND A FERNCO FITTING

INLET CHOICES

4" DWV PIPE (4.50 OD)	<input type="checkbox"/>
4" DR35 PIPE (4.22 OD)	<input type="checkbox"/>
6" DWV PIPE (6.63 OD)	<input type="checkbox"/>
6" DR35 PIPE (6.28 OD)	<input type="checkbox"/>
8" DWV PIPE (8.63 OD)	<input type="checkbox"/>
8" DR35 PIPE (8.40 OD)	<input type="checkbox"/>



SGS	04-27-09	A	1/32
DR BY	CHK'D	DATE	ISSUE SCALE



DETAIL SHEET  
W SERIES QUADPLEX

NA0154P01

ALARM  
ON  
OFF  
13" 160 gal  
17" 209 gal  
25" 308 gal  
↑ VOLUMES SHOWN ARE FOR Ø60"

STATION TO BE USED WITH  
(2) MOD T260 DUPLEX PANELS

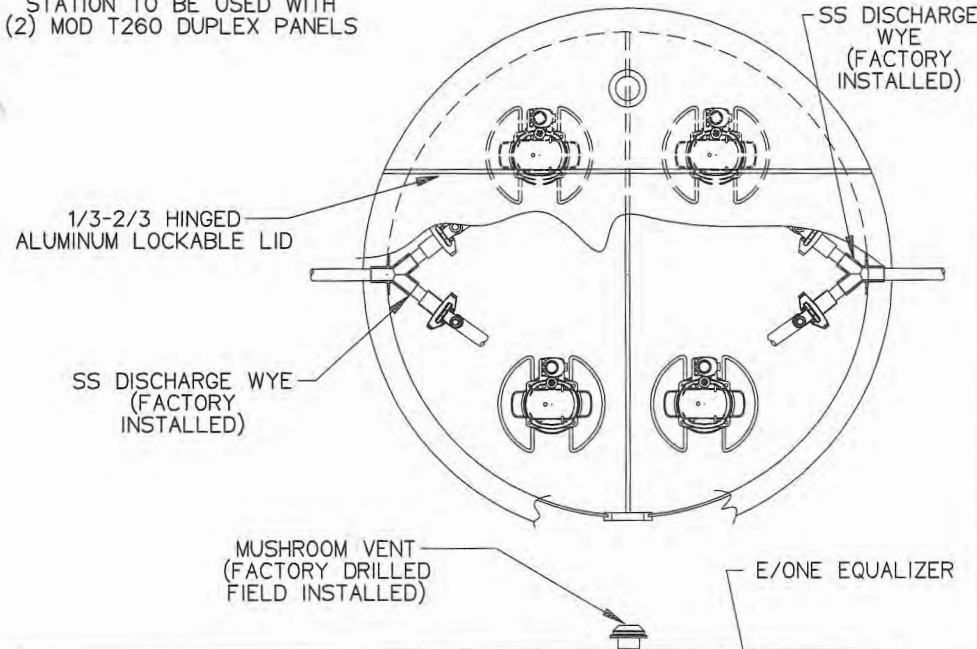

DIAMETER CHOICES

"D"  
1.52   
1.83

W SERIES  
QUADPLEX  
STATIONS

HEIGHT CHOICES

"H" COD RANGE

1.52 (.61)   
1.68 (.61-.76)   
1.83 (.61-.91)   
1.98 (.61-1.07)   
2.13 (.61-1.22)   
2.29 (.61-1.37)   
2.44 (.61-1.52)   
2.59 (.61-1.68)   
2.74 (.61-1.83)   
2.90 (.61-1.98)   
3.05 (.61-2.13)   
3.20 (.61-2.29)   
3.35 (.61-2.44)   
3.51 (.61-2.59)   
3.66 (.61-2.74)

COVER OVER  
DISCH CHOICES

"COD"

0.61   
0.76   
0.91   
1.07   
1.22   
1.37   
1.52   
1.68   
1.83   
1.98   
2.13   
2.29   
2.44   
2.59   
2.74

(DIMENSIONS ABOVE ARE IN METERS)

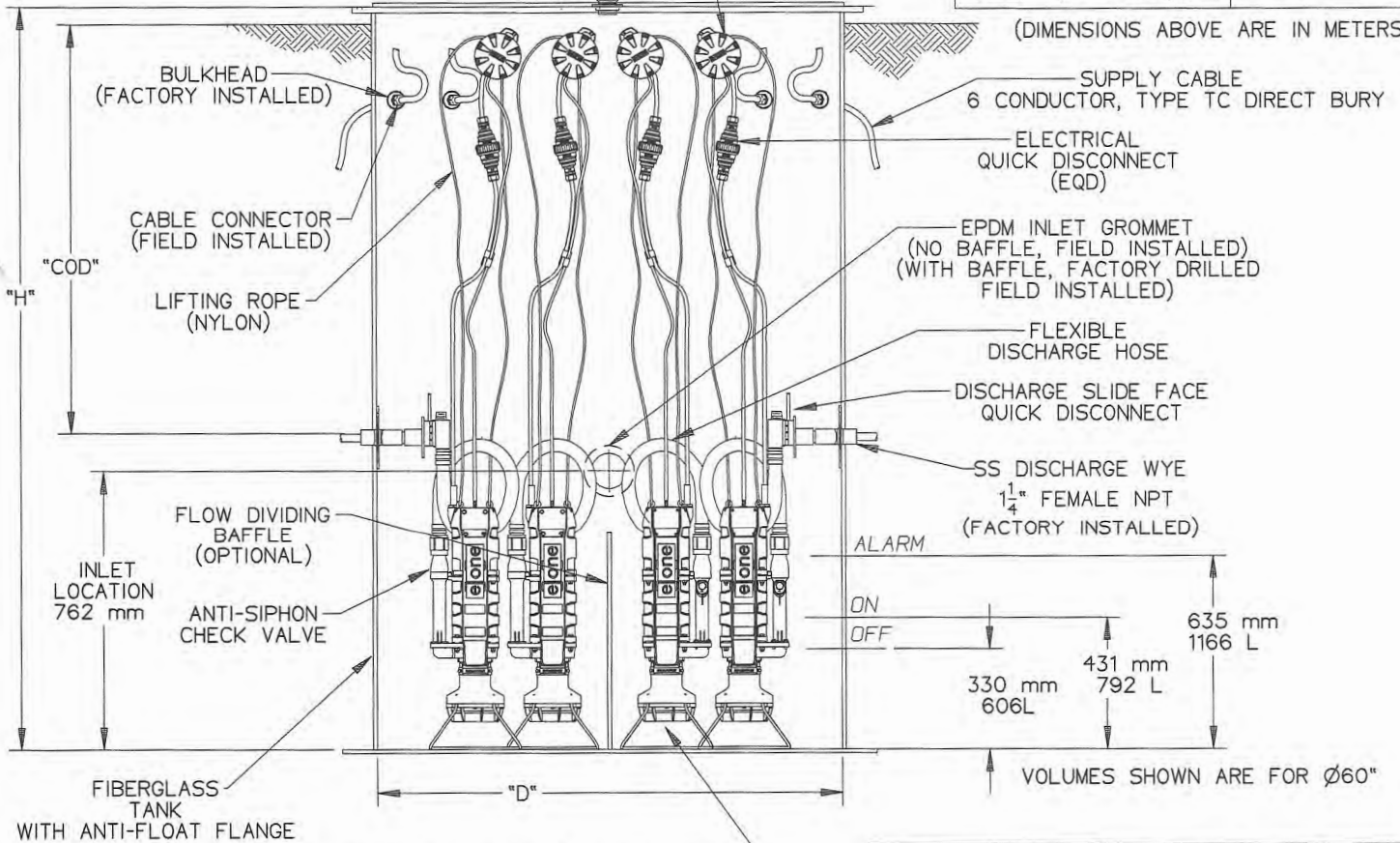

FOUR SEMI-POSITIVE DISPLACEMENT TYPE PUMP  
DIRECTLY DRIVEN BY 1 HP MOTOR

NOTE:

- 4" & 6" INLETS ARE EPDM GROMMETS
- 8" DWV INLET IS A CAST IRON CAULKING HUB
- 8" DR35 INLET IS A CAST IRON CAULKING HUB AND A FERNCO FITTING

INLET CHOICES

4" DWV PIPE (4.50 OD)   
4" DR35 PIPE (4.22 OD)   
6" DWV PIPE (6.63 OD)   
6" DR35 PIPE (6.28 OD)   
8" DWV PIPE (8.63 OD)   
8" DR35 PIPE (8.40 OD)



PJS	12-10-10	-	1/32
DR BY	CHK'D	DATE	ISSUE SCALE



SEWER SYSTEMS

DETAIL SHEET  
W SERIES QUADPLEX, METRIC

NA0154P02

(1) STATION TO BE USED WITH  
 (1) MOD T260 DUPLEX PANEL AND  
 (1) SENTRY SIMPLEX PANEL

1/3-2/3 HINGED  
 ALUMINUM LOCKABLE LID

DISCHARGE

SS DISCHARGE WYE

SS DISCHARGE

DISCHARGE

BACKUP PUMP, RUN BY A SIMPLEX PANEL  
 ON A 4" BLOCK (BY OTHERS)

MUSHROOM VENT  
 (FACTORY DRILLED  
 FIELD INSTALLED)

E/ONE EQUALIZER

ELECTRICAL  
 QUICK DISCONNECT (EQD)

(DIMENSIONS ARE IN INCHES)

BULKHEAD  
 (FACTORY INSTALLED)

CABLE CONNECTOR  
 (FIELD INSTALLED)

LIFTING ROPE  
 (NYLON)

SS DISCHARGE WYE  
 1 1/4" FEMALE NPT  
 (FACTORY INSTALLED)

ANTI-SIPHON  
 CHECK VALVE

INLET  
 LOCATION  
 VARIABLE  
 30" MIN

(2) MAIN PUMPS  
 RUN BY A MOD T260  
 DUPLEX PANEL

FIBERGLASS  
 TANK  
 WITH ANTI-FLOAT FLANGE

(3) SEMI-POSITIVE DISPLACEMENT TYPE PUMP  
 DIRECTLY DRIVEN BY 1 HP MOTOR

DIAMETER CHOICES

"D"  
 48   
 60

W SERIES  
 TRIPLEX  
 STATIONS

HEIGHT CHOICES

"H"	COD RANGE	
60	(24)	<input type="checkbox"/>
66	(24-30)	<input type="checkbox"/>
72	(24-36)	<input type="checkbox"/>
78	(24-42)	<input type="checkbox"/>
84	(24-48)	<input type="checkbox"/>
90	(24-54)	<input type="checkbox"/>
96	(24-60)	<input type="checkbox"/>
102	(24-66)	<input type="checkbox"/>
108	(24-72)	<input type="checkbox"/>
114	(24-78)	<input type="checkbox"/>
120	(24-84)	<input type="checkbox"/>
126	(24-90)	<input type="checkbox"/>
132	(24-96)	<input type="checkbox"/>
138	(24-102)	<input type="checkbox"/>
144	(24-108)	<input type="checkbox"/>

COVER OVER  
 DISCH CHOICES

"COD"	
24	<input type="checkbox"/>
30	<input type="checkbox"/>
36	<input type="checkbox"/>
42	<input type="checkbox"/>
48	<input type="checkbox"/>
54	<input type="checkbox"/>
60	<input type="checkbox"/>
66	<input type="checkbox"/>
72	<input type="checkbox"/>
78	<input type="checkbox"/>
84	<input type="checkbox"/>
90	<input type="checkbox"/>
96	<input type="checkbox"/>
102	<input type="checkbox"/>
108	<input type="checkbox"/>

SUPPLY CABLE  
 6 CONDUCTOR, TYPE TC  
 DIRECT BURY CABLE

"COD"

EPDM INLET GROMMET  
 (FIELD INSTALLED)

DISCHARGE SLIDE FACE  
 QUICK DISCONNECT

SS DISCHARGE HUB  
 1 1/4" FEMALE NPT  
 (FACTORY INSTALLED)

"H"

FLEXIBLE  
 DISCHARGE HOSE

ALARM

ON

OFF

13"  
 102 gal

17"  
 133 gal

25"  
 196 gal

VOLUMES SHOWN ARE FOR Ø48

SGS	04-27-09	A	1/32
DR BY	CHK'D	DATE	ISSUE SCALE



DETAIL SHEET  
 W SERIES TRIPLEX

NA0155P01

INLET CHOICES

- 4" DWV PIPE (4.50 OD)
- 4" DR35 PIPE (4.22 OD)
- 6" DWV PIPE (6.63 OD)
- 6" DR35 PIPE (6.28 OD)





(1) STATION TO BE USED WITH  
 MOD T260 DUPLEX PANEL AND  
 (1) SENTRY SIMPLEX PANEL

1/3-2/3 HINGED  
 ALUMINUM LOCKABLE LID

DISCHARGE

SS DISCHARGE WYE

SS DISCHARGE

DISCHARGE

BACKUP PUMP, RUN BY A SIMPLEX PANEL  
 ON A 4" BLOCK (BY OTHERS)

DIAMETER CHOICES

"D"  
 1.22   
 1.52

W SERIES  
 TRIPLEX  
 STATIONS

HEIGHT CHOICES

"H"	COD RANGE	
1.52	(.61)	<input type="checkbox"/>
1.68	(.61-.76)	<input type="checkbox"/>
1.83	(.61-.91)	<input type="checkbox"/>
1.98	(.61-1.07)	<input type="checkbox"/>
2.13	(.61-1.22)	<input type="checkbox"/>
2.29	(.61-1.37)	<input type="checkbox"/>
2.44	(.61-1.52)	<input type="checkbox"/>
2.59	(.61-1.68)	<input type="checkbox"/>
2.74	(.61-1.83)	<input type="checkbox"/>
2.90	(.61-1.98)	<input type="checkbox"/>
3.05	(.61-2.13)	<input type="checkbox"/>
3.20	(.61-2.29)	<input type="checkbox"/>
3.35	(.61-2.44)	<input type="checkbox"/>
3.51	(.61-2.59)	<input type="checkbox"/>
3.66	(.51-2.74)	<input type="checkbox"/>

COVER OVER  
 DISCH CHOICES

"COD"	
0.61	<input type="checkbox"/>
0.76	<input type="checkbox"/>
0.91	<input type="checkbox"/>
1.07	<input type="checkbox"/>
1.22	<input type="checkbox"/>
1.37	<input type="checkbox"/>
1.52	<input type="checkbox"/>
1.68	<input type="checkbox"/>
1.83	<input type="checkbox"/>
1.98	<input type="checkbox"/>
2.13	<input type="checkbox"/>
2.29	<input type="checkbox"/>
2.44	<input type="checkbox"/>
2.59	<input type="checkbox"/>
2.74	<input type="checkbox"/>

(DIMENSIONS ABOVE ARE IN METERS)

MUSHROOM VENT  
 (FACTORY DRILLED  
 FIELD INSTALLED)

E/ONE EQUALIZER

ELECTRICAL  
 QUICK DISCONNECT (EQD)

BULKHEAD  
 (FACTORY INSTALLED)

CABLE CONNECTOR  
 (FIELD INSTALLED)

LIFTING ROPE  
 (NYLON)

SS DISCHARGE WYE  
 1 1/4" FEMALE NPT  
 (FACTORY INSTALLED)

ANTI-SIPHON  
 CHECK VALVE

INLET  
 LOCATION  
 VARIABLE  
 762 mm MIN

(2) MAIN PUMPS  
 RUN BY A MOD T260  
 DUPLEX PANEL

FIBERGLASS  
 TANK  
 WITH ANTI-FLOAT FLANGE

(3) SEMI-POSITIVE DISPLACEMENT TYPE PUMP  
 DIRECTLY DRIVEN BY 1 HP MOTOR

SUPPLY CABLE  
 6 CONDUCTOR, TYPE TC  
 DIRECT BURY CABLE

EPDM INLET GROMMET  
 (FIELD INSTALLED)

DISCHARGE SLIDE FACE  
 QUICK DISCONNECT

SS DISCHARGE HUB  
 1 1/4" FEMALE NPT  
 (FACTORY INSTALLED)

FLEXIBLE  
 DISCHARGE HOSE

ALARM

ON

OFF

330 mm  
 386 L

431 mm  
 504 L

635 mm  
 742 L

VOLUMES SHOWN ARE FOR Ø48

INLET CHOICES	
4" DWV PIPE (4.50 OD)	<input type="checkbox"/>
4" DR35 PIPE (4.22 OD)	<input type="checkbox"/>
6" DWV PIPE (6.63 OD)	<input type="checkbox"/>
6" DR35 PIPE (6.28 OD)	<input type="checkbox"/>

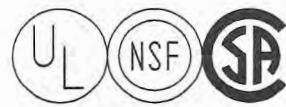

PJS	12-09-10	-	1/32
DR BY	CHK'D	DATE	ISSUE SCALE



DETAIL SHEET  
 W SERIES TRIPLEX, METRIC

NA0155P02

STATION TO BE USED WITH  
(1) MOD T260 DUPLEX PANEL

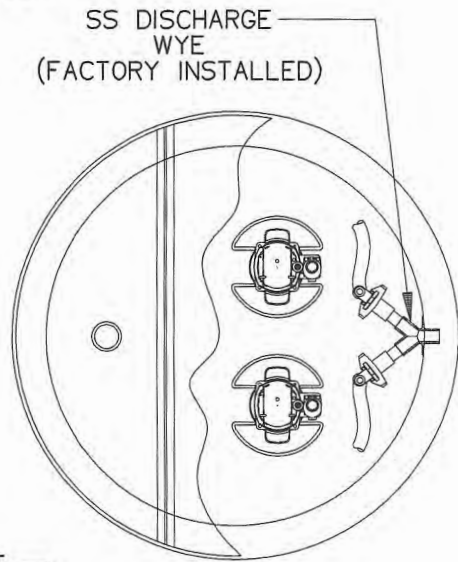

DIAMETER CHOICES		W SERIES DUPLEX STATIONS
"D"		
36	<input type="checkbox"/>	
42	<input type="checkbox"/>	
48	<input type="checkbox"/>	
60	<input type="checkbox"/>	

HEIGHT CHOICES		COVER OVER DISCH CHOICES
"H"	COD RANGE	
60	( 24 ) <input type="checkbox"/>	"COD" 24 <input type="checkbox"/>
66	(24-30) <input type="checkbox"/>	30 <input type="checkbox"/>
72	(24-36) <input type="checkbox"/>	36 <input type="checkbox"/>
78	(24-42) <input type="checkbox"/>	42 <input type="checkbox"/>
84	(24-48) <input type="checkbox"/>	48 <input type="checkbox"/>
90	(24-54) <input type="checkbox"/>	54 <input type="checkbox"/>
96	(24-60) <input type="checkbox"/>	60 <input type="checkbox"/>
102	(24-66) <input type="checkbox"/>	66 <input type="checkbox"/>
108	(24-72) <input type="checkbox"/>	72 <input type="checkbox"/>
114	(24-78) <input type="checkbox"/>	78 <input type="checkbox"/>
120	(24-84) <input type="checkbox"/>	84 <input type="checkbox"/>
126	(24-90) <input type="checkbox"/>	90 <input type="checkbox"/>
132	(24-96) <input type="checkbox"/>	96 <input type="checkbox"/>
138	(24-102) <input type="checkbox"/>	102 <input type="checkbox"/>
144	(24-108) <input type="checkbox"/>	108 <input type="checkbox"/>

(DIMENSIONS ARE IN INCHES)

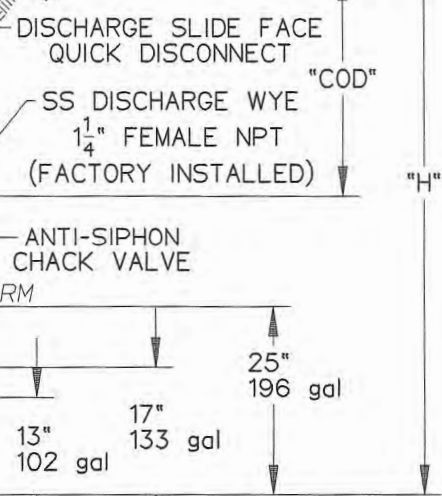
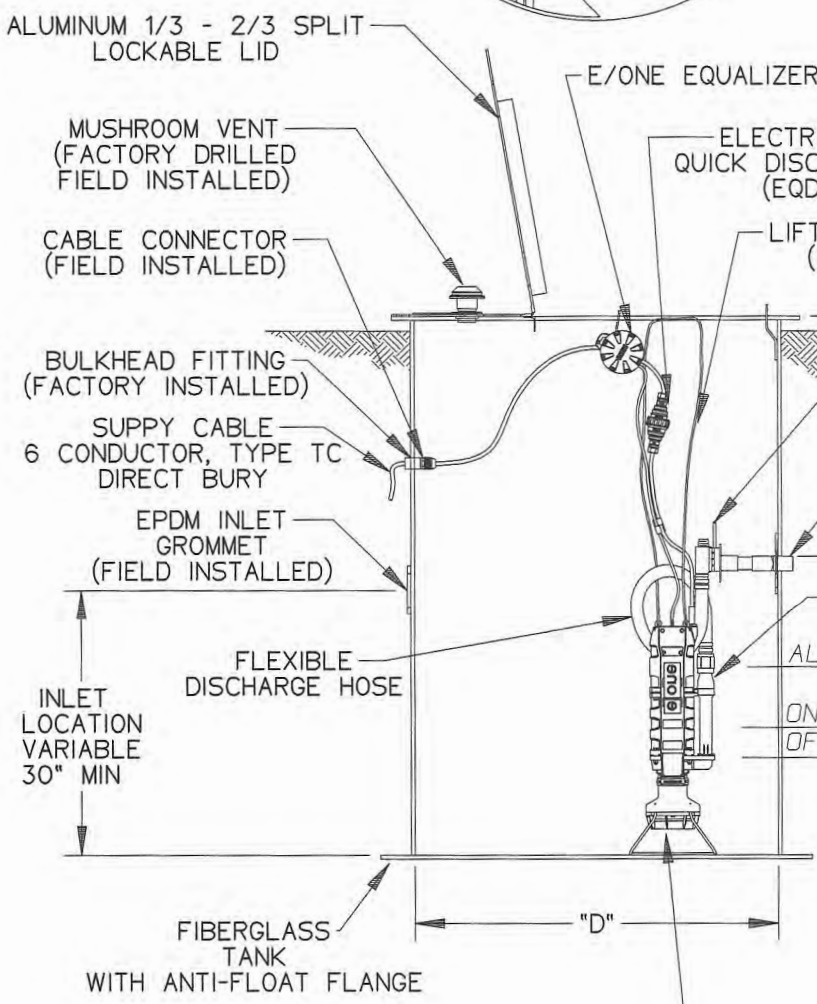

INLET CHOICES	
4" DWV PIPE (4.50 OD)	<input type="checkbox"/>
4" DR35 PIPE (4.22 OD)	<input type="checkbox"/>
6" DWV PIPE (6.63 OD)	<input type="checkbox"/>
6" DR35 PIPE (6.28 OD)	<input type="checkbox"/>



SGS	04-27-09	A	1/32
DR BY	CHK'D	DATE	ISSUE SCALE



DETAIL SHEET,  
W SERIES DUPLEX

NA0156P01

STATION TO BE USED WITH  
(1) MOD T260 DUPLEX PANEL

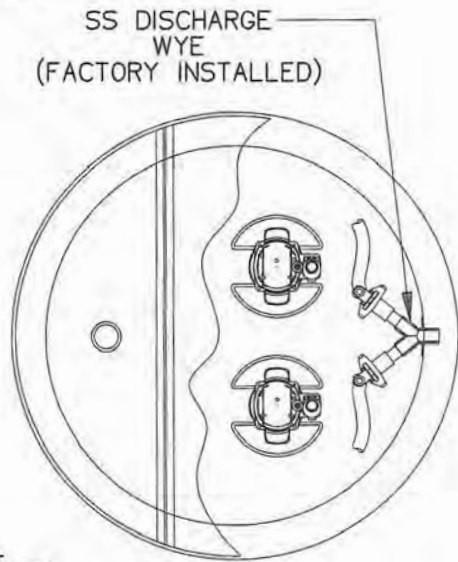

DIAMETER CHOICES		W SERIES DUPLEX STATIONS
"D"		
0.91	<input type="checkbox"/>	
1.07	<input type="checkbox"/>	
1.22	<input type="checkbox"/>	
1.52	<input type="checkbox"/>	

HEIGHT CHOICES		COVER OVER DISCH CHOICES
"H"	COD RANGE	
1.52	(.61)	0.61
1.68	(.61-.76)	0.76
1.83	(.61-.91)	0.91
1.98	(.61-1.07)	1.07
2.13	(.61-1.22)	1.22
2.29	(.61-1.37)	1.37
2.44	(.61-1.52)	1.52
2.59	(.61-1.68)	1.68
2.74	(.61-1.83)	1.83
2.90	(.61-1.98)	1.98
3.05	(.61-2.13)	2.13
3.20	(.61-2.29)	2.29
3.35	(.61-2.44)	2.44
3.51	(.61-2.59)	2.59
3.66	(.61-2.74)	2.74

(DIMENSIONS ABOVE ARE IN METERS)

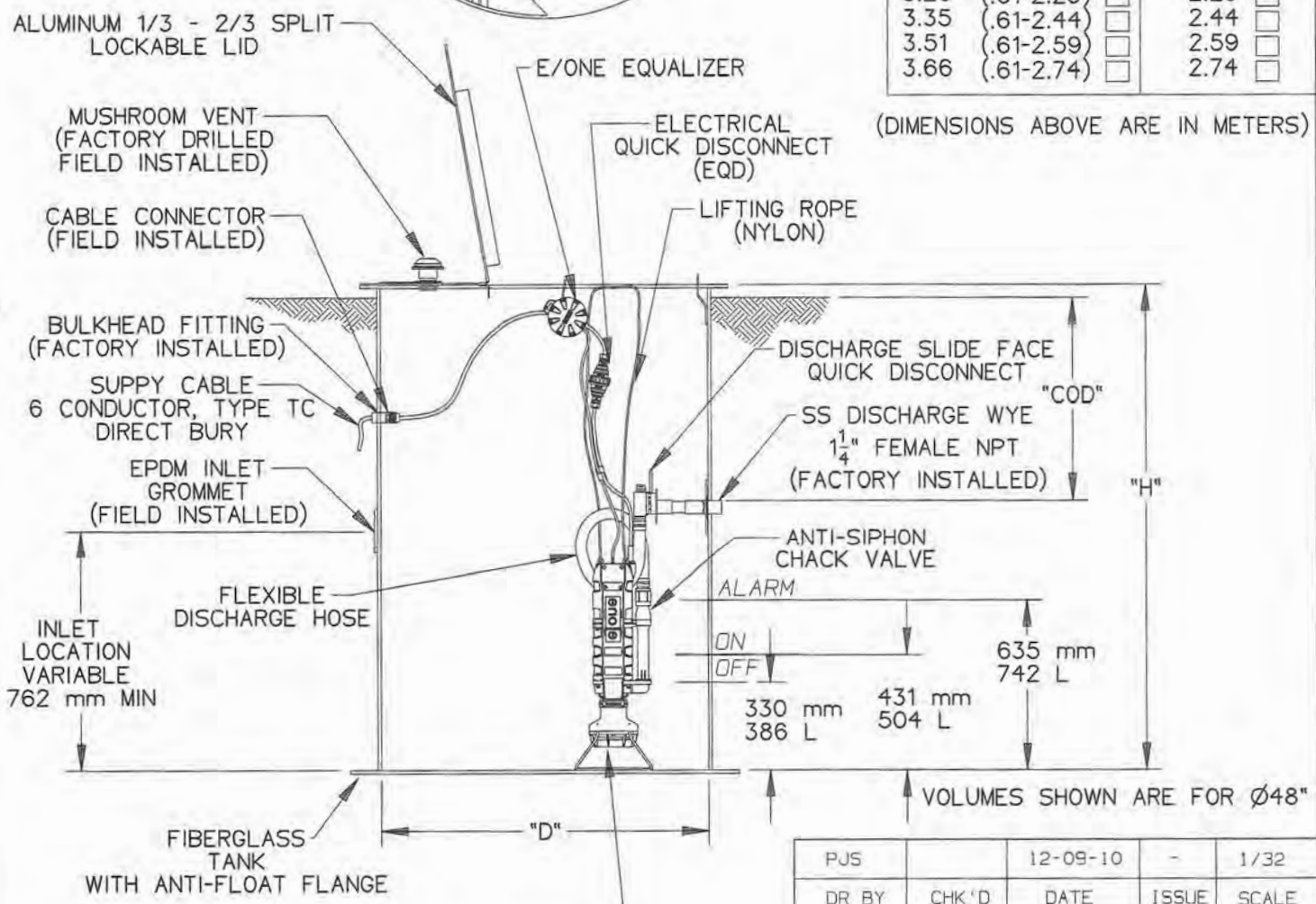

INLET CHOICES	
4" DWV PIPE (4.50 OD)	<input type="checkbox"/>
4" DR35 PIPE (4.22 OD)	<input type="checkbox"/>
6" DWV PIPE (6.63 OD)	<input type="checkbox"/>
6" DR35 PIPE (6.28 OD)	<input type="checkbox"/>



ON	635 mm	742 L
OFF	330 mm	386 L
	431 mm	504 L

VOLUMES SHOWN ARE FOR Ø48"

PJS	12-09-10	-	1/32
DR BY	CHK'D	DATE	ISSUE SCALE



DETAIL SHEET,  
W SERIES DUPLEX, METRIC

NA0156P02

STATION TO BE USED WITH  
(1) SENTRY SIMPLEX PANEL

DIAMETER CHOICES			W SERIES SIMPLEX STATIONS	
"D"				
24	<input type="checkbox"/>			
30	<input type="checkbox"/>			
36	<input type="checkbox"/>			
HEIGHT CHOICES			COVER OVER DISCH CHOICES	
"H"	COD RANGE		"COD"	
60	( 24 )	<input type="checkbox"/>	24	<input type="checkbox"/>
66	(24-30)	<input type="checkbox"/>	30	<input type="checkbox"/>
72	(24-36)	<input type="checkbox"/>	36	<input type="checkbox"/>
78	(24-42)	<input type="checkbox"/>	42	<input type="checkbox"/>
84	(24-48)	<input type="checkbox"/>	48	<input type="checkbox"/>
90	(24-54)	<input type="checkbox"/>	54	<input type="checkbox"/>
96	(24-60)	<input type="checkbox"/>	60	<input type="checkbox"/>
102	(24-66)	<input type="checkbox"/>	66	<input type="checkbox"/>
108	(24-72)	<input type="checkbox"/>	72	<input type="checkbox"/>
114	(24-78)	<input type="checkbox"/>	78	<input type="checkbox"/>
120	(24-84)	<input type="checkbox"/>	84	<input type="checkbox"/>
126	(24-90)	<input type="checkbox"/>	90	<input type="checkbox"/>
132	(24-96)	<input type="checkbox"/>	96	<input type="checkbox"/>
138	(24-102)	<input type="checkbox"/>	102	<input type="checkbox"/>
144	(24-108)	<input type="checkbox"/>	108	<input type="checkbox"/>

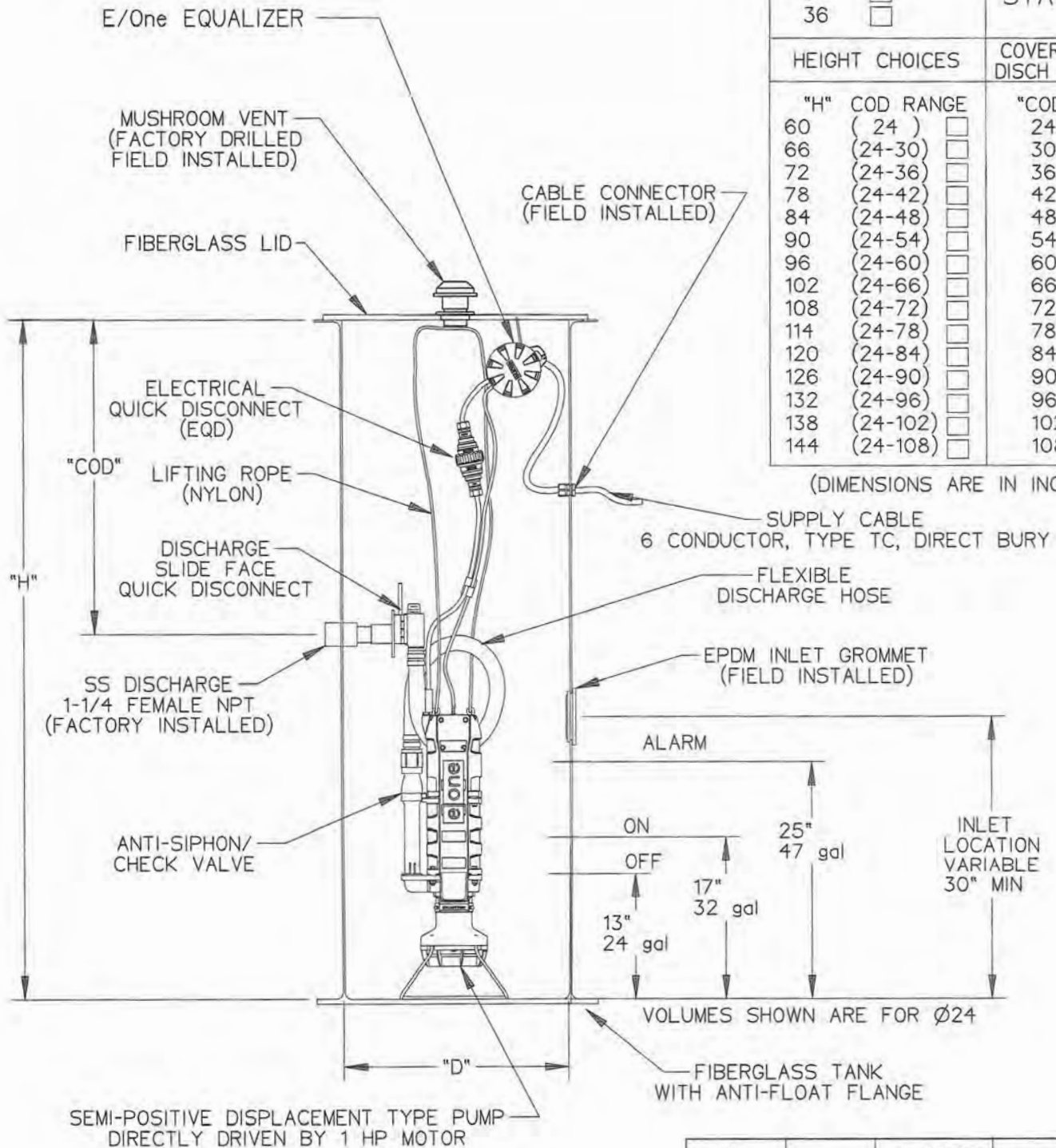

INLET CHOICES	
4" DWV PIPE (4.50 OD)	<input type="checkbox"/>
4" DR35 PIPE (4.22 OD)	<input type="checkbox"/>
6" DWV PIPE (6.63 OD)	<input type="checkbox"/>
6" DR35 PIPE (6.28 OD)	<input type="checkbox"/>

SGS		04-27-09	A	1/16
DR BY	CHK'D	DATE	ISSUE	SCALE



DETAIL SHEET,  
W SERIES SIMPLEX

NA0157P01





STATION TO BE USED WITH  
(1) SENTRY SIMPLEX PANEL

DIAMETER CHOICES

- "D"  
 .610   
 .762   
 .914

W SERIES  
SIMPLEX  
STATIONS

HEIGHT CHOICES

- | "H"  | COD RANGE  |                          |
|------|------------|--------------------------|
| 1.52 | (.61)      | <input type="checkbox"/> |
| 1.68 | (.61-.76)  | <input type="checkbox"/> |
| 1.83 | (.61-.91)  | <input type="checkbox"/> |
| 1.98 | (.61-1.07) | <input type="checkbox"/> |
| 2.13 | (.61-1.22) | <input type="checkbox"/> |
| 2.29 | (.61-1.37) | <input type="checkbox"/> |
| 2.44 | (.61-1.52) | <input type="checkbox"/> |
| 2.59 | (.61-1.68) | <input type="checkbox"/> |
| 2.74 | (.61-1.83) | <input type="checkbox"/> |
| 2.90 | (.61-1.98) | <input type="checkbox"/> |
| 3.05 | (.61-2.13) | <input type="checkbox"/> |
| 3.20 | (.61-2.29) | <input type="checkbox"/> |
| 3.35 | (.61-2.44) | <input type="checkbox"/> |
| 3.51 | (.61-2.59) | <input type="checkbox"/> |
| 3.66 | (.61-2.74) | <input type="checkbox"/> |

COVER OVER  
DISCH CHOICES

- | "COD" |                          |
|-------|--------------------------|
| 0.61  | <input type="checkbox"/> |
| 0.76  | <input type="checkbox"/> |
| 0.91  | <input type="checkbox"/> |
| 1.07  | <input type="checkbox"/> |
| 1.22  | <input type="checkbox"/> |
| 1.37  | <input type="checkbox"/> |
| 1.52  | <input type="checkbox"/> |
| 1.68  | <input type="checkbox"/> |
| 1.83  | <input type="checkbox"/> |
| 1.98  | <input type="checkbox"/> |
| 2.13  | <input type="checkbox"/> |
| 2.29  | <input type="checkbox"/> |
| 2.44  | <input type="checkbox"/> |
| 2.59  | <input type="checkbox"/> |
| 2.74  | <input type="checkbox"/> |

(DIMENSIONS ABOVE ARE IN METERS)

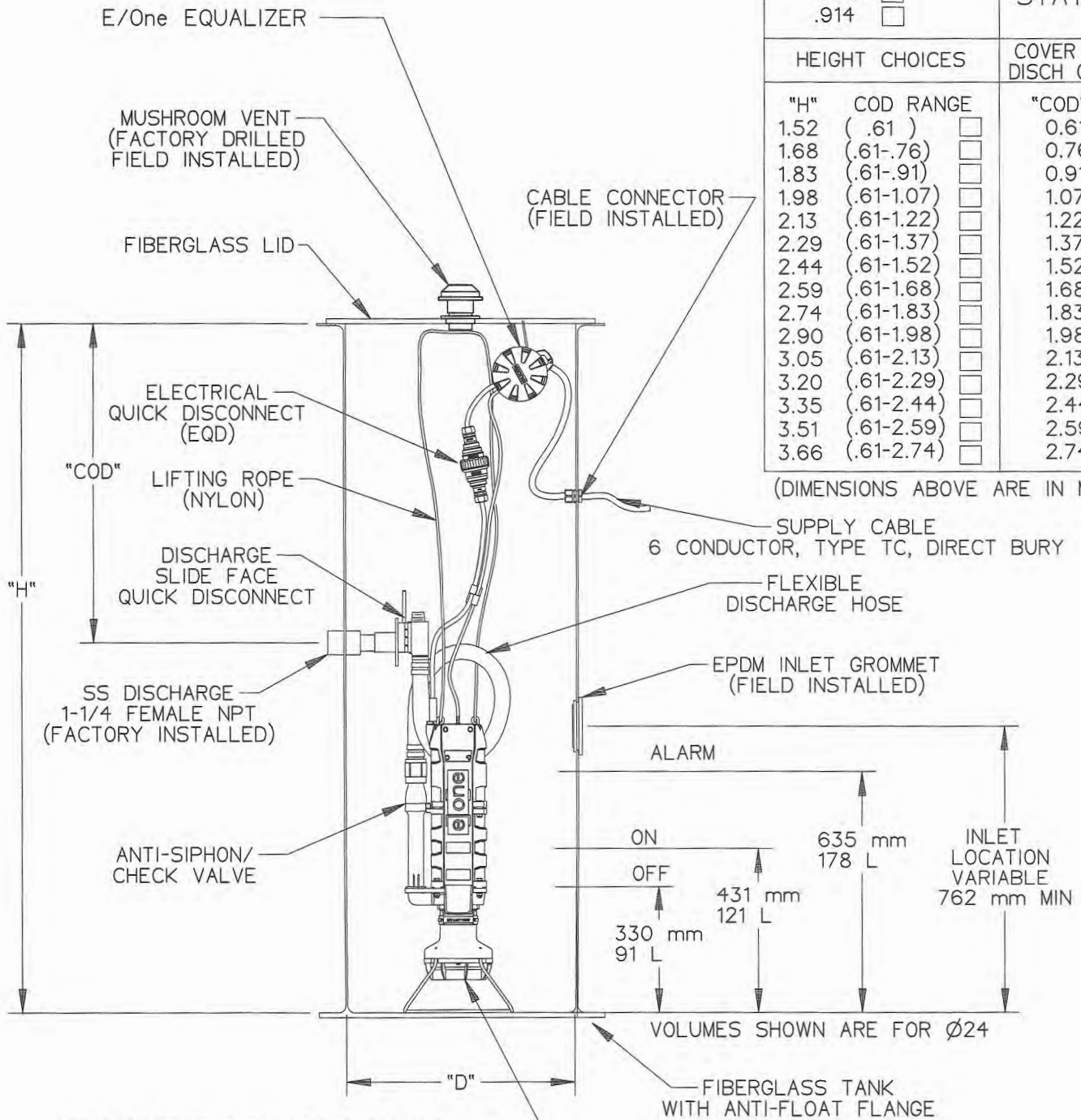

SEMI-POSITIVE DISPLACEMENT TYPE PUMP  
DIRECTLY DRIVEN BY 1 HP MOTOR

INLET CHOICES	
4" DWV PIPE (4.50 OD)	<input type="checkbox"/>
4" DR35 PIPE (4.22 OD)	<input type="checkbox"/>
6" DWV PIPE (6.63 OD)	<input type="checkbox"/>
6" DR35 PIPE (6.28 OD)	<input type="checkbox"/>

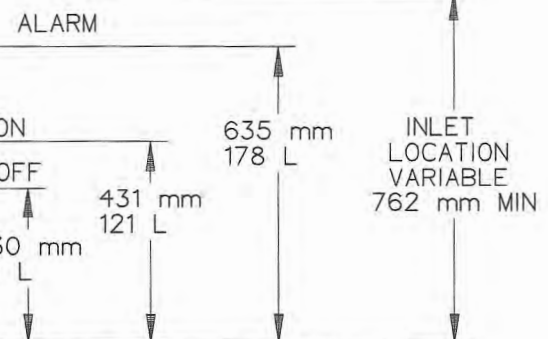

VOLUMES SHOWN ARE FOR Ø24



PJS		12-09-10	-	1/16
DR BY	CHK'D	DATE	ISSUE	SCALE



DETAIL SHEET,  
W SERIES SIMPLEX, METRIC

NA0157P02

# EJONE SPD PUMP PERFORMANCE CURVE

GRINDER PUMP, 1HP, 1725 RPM

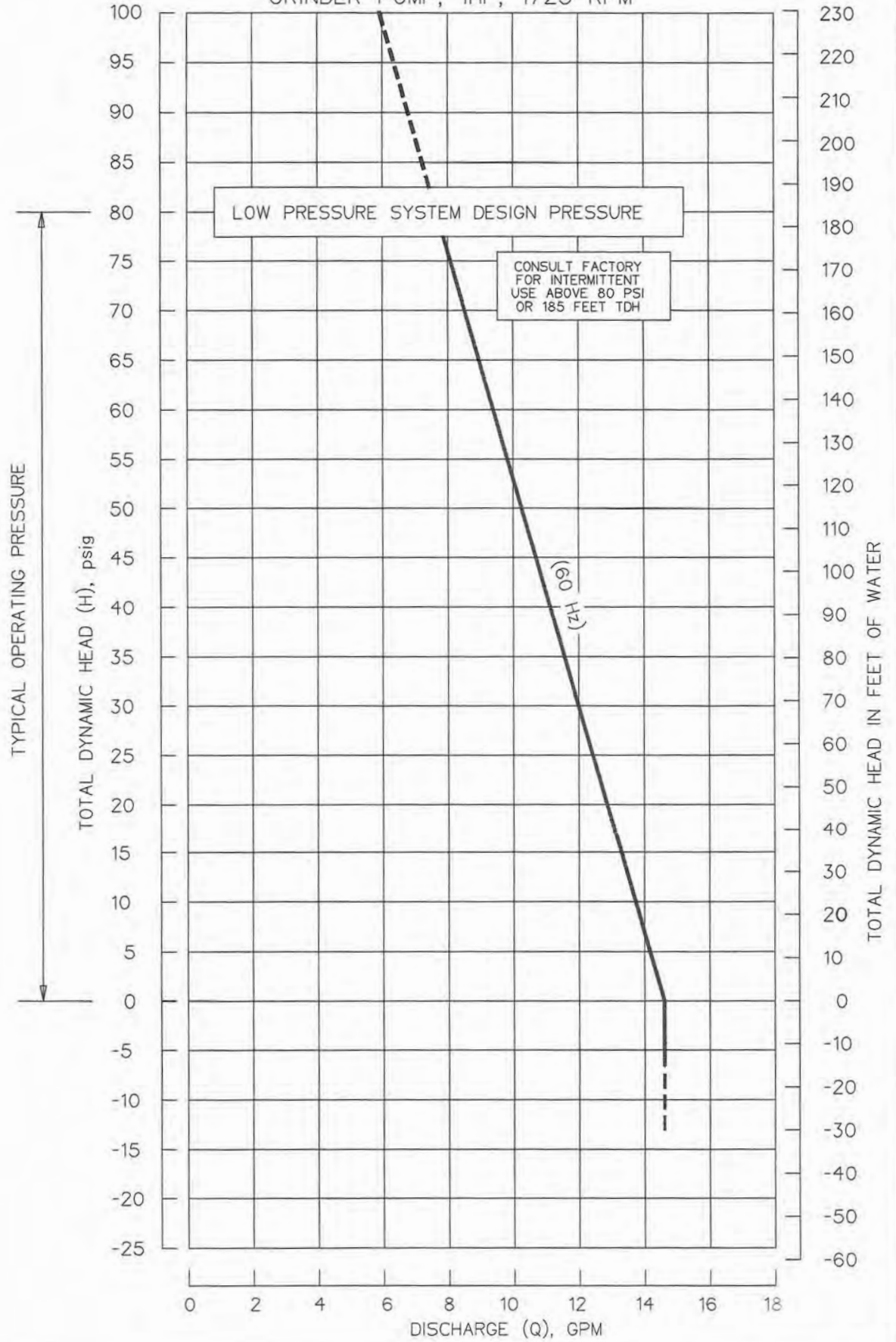

## Omnivore® Sewage and Grinder Pumps

### Models:

LSG202A	2 hp, 208/230V, 1 phase, Automatic
LSG202M	2 hp, 208/230V, 1 phase, Manual
LSG202M-C	2 hp, 208/230V, 1 phase, Manual, external caps
LSG203M	2 hp, 208/230V, 3 phase, Manual
LSG204M	2 hp, 440-480V, 3 phase, Manual
LSG205M	2 hp, 575V, 3 phase, Manual
LSGX202A	2 hp, 2-Stage, 208-230V, 1 phase, Automatic
LSGX202M	2 hp, 2-Stage, 208-230V, 1 phase, Manual
LSGX202M-C	2 hp, 2-Stage, 208-230V, 1 phase, Manual, external caps
LSGX203M	2 hp, 2-Stage, 208/230V, 3 phase, Manual
LSGX204M	2 hp, 2-Stage, 440-480V, 3 phase, Manual
LSGX205M	2 hp, 2-Stage, 575V, 3 phase, Manual
<b>*Do not throw away or lose this manual.</b>	



## Contents

- General Information
- Introduction
- Mechanical Installation
- Electrical Connection
- Operation
- Warranty

### IMPORTANT:

Prior to installation, record Model, Serial Number, and Code Number from pump nameplate for future reference.

MODEL \_\_\_\_\_

SERIAL \_\_\_\_\_

CODE \_\_\_\_\_

INSTALLATION  
DATE \_\_\_\_\_

## Liberty Pumps®

7000 Apple Tree Avenue  
Bergen, NY 14416  
Phone: (800) 543-2550  
Fax: (585) 494-1839  
www.libertypumps.com





# 1. General Information

Before installation, read the following instructions carefully. Each Liberty pump is individually factory tested to insure proper performance. Closely following these instructions will eliminate potential operating problems, assuring years of trouble-free service.

## ⚠ WARNING

- **Risk of electric shock.** Always disconnect the pump from the power source before handling or making adjustments.
- The electrical connections and wiring for a pump installation should only be made by qualified personnel.
- This pump is supplied with a grounding conductor and grounding-type attachment plug. To reduce the risk of electric shock, be certain that it is connected only to a properly grounded, grounding-type receptacle.
- DO NOT bypass grounding wires or remove ground prong from attachment plugs.
- DO NOT use an extension cord.
- This pump requires a separate, properly fused and grounded branch circuit. Make sure the power source is properly sized for the voltage and amperage requirements of the pump, as noted on the nameplate.
- The electrical outlet shall be within the length limitations of the pump power cord, and at least 4 feet above floor level to minimize possible hazards from flood conditions.
- The installation must be in accordance with the National Electric Code, Uniform Plumbing Code, International Plumbing Code, as well as all applicable local codes and ordinances.
- Sump and sewage pumps often handle materials which could cause illness or disease. Wear adequate protective clothing when working on a used pump or piping.
- Never enter a pump basin after it has been used. Sewage and effluent can emit several gases which are poisonous.
- Keep clear of suction and discharge openings. To prevent injury, never insert fingers into pump while it is plugged in.
- DO NOT use this product for flammable or corrosive liquid.
- DO NOT use this product in applications where human contact with the pumped fluid is common (such as swimming pools, fountains, etc.)
- NEVER dispose of materials such as paint thinner or other chemicals down drains, as they can chemically attack and damage pump components, potentially causing product malfunction or failure.

## ⚠ CAUTION

- Do not use these pumps in water over 140° F.
- The Uniform Plumbing Code (UPC) states that sewage systems shall have an audio and visual alarm that signals a malfunction of the system, to reduce the potential for property damage.

Model	HP	Volts	Phase	Full Load Amps	FNPT Discharge	Automatic or Manual*
LSG202A	2	208/230	1	15	1.25"	Automatic
LSG202M	2	208/230	1	15	1.25"	Manual
LSG202M-C	2	208/230	1	15	1.25"	Manual
LSG203M	2	208/230	3	10.6	1.25"	Manual
LSG204M	2	440-480	3	5.3	1.25"	Manual
LSG205M	2	575	3	4.9	1.25"	Manual
LSGX202A	2	208-230	1	15	1.25"	Automatic
LSGX202M	2	208-230	1	15	1.25"	Manual
LSGX202M-C	2	208-230	1	15	1.25"	Manual
LSGX203M	2	208/230	3	10.6	1.25"	Manual
LSGX204M	2	440-480	3	5.3	1.25"	Manual
LSGX205M	2	575	3	4.9	1.25"	Manual

\* **Note:** Manual models ("M" suffix), require a separate approved pump control device or panel for automatic operation. Operation of these models will be according to the control selected. Make sure the electrical specifications of the control selected properly match the electrical specifications of the pump. Always refer to control panel instructions for proper installation.

Models with ("M-C" suffix) require external capacitors and relay.  
 (Order kit K001316)  
 start cap - 200-240, 220V  
 or 216 - 259 uf, 250V  
 run cap - 50 uf, 370V  
 Mars Potential Relay 19551 (#551)  
 pick up 244V - 270V  
 drop out of 40V-90V



## 2. Introduction

### 2-1 INTRODUCTION

This manual was prepared to assist you in the correct installation, operation, and maintenance of your Liberty pump. Please read it completely before installing the pump. Make certain that you are familiar with the contents, and the chapters on installation and operation are fully understood before running the pump.

Liberty Pumps are designed for minimal maintenance. However, regular checks will ensure longer life and greater operating reliability.

**WARRANTY:** No repair work should be carried out during the warranty period without prior factory approval. To do so may render the warranty void.

**SERIAL #:** In all correspondence and reports, make certain that the pump serial number is given.

### 2-2.1 DESIGN OF PUMP

#### **⚠ WARNING**

**The grinder pump contains metal parts that rotate at high speeds. Be careful around pump base while power is connected. Make sure that the pump is either in the tank or clear from people and wires when in operation.**

1. Liberty LSG and LSGX-Series grinder pumps are designed for continuous underwater operation. The motor and pump form a close coupled, watertight unit. The induction motor is insulated against heat and moisture in accordance with Class B 265F (130C) regulations.
2. A thermal overload protector is imbedded in the stator windings. This is connected in series and wired to shut down the pump if overheating occurs. The overload switch resets automatically when the motor cools.
3. The motor is protected against damage from water entry by two seals. The lower seal is a Viton lip seal. The upper seal is mechanical, consisting of two silicon-carbide faces.
4. The impeller and volute are designed for efficient flow characteristics and clog-free operation. The hardened cutters grind solids and fibrous matter into small particles that can be safely pumped through small diameter piping.
5. For sewage systems, consult local plumbing codes on requirements of venting the tank. The pump shall not be installed in locations classified as hazardous in accordance with the National Electrical Code, ANSI/ NFPA70.

**NOTE: The major material of Liberty LSG and LSGX-Series pumps is cast iron. They should not be used to pump corrosive liquids.**

## 3. Mechanical Installation

### 3-1 INSPECTION UPON RECEIPT

The shipping container should be immediately inspected for damage that may have occurred in shipment. Exercise care in opening the shipping container to avoid damage to the pump. Remove any blocking and cushioning from within the container.

Check all cushioning for spare parts before discarding. Visually check the pump and any spare parts for damage. Check for damaged electrical wires, especially where they exit the motor housing. Contact the Liberty Pumps Customer Service Department to report any damage or shortage of parts. Turn the hex socket head cap screw at the center of the cutter wheel on the bottom of the grinder several rotations clockwise. This will insure that the impeller and cutter are free of any seizure due to prolonged storage. If the impeller is not rotated manually prior to installation, the pump may fail to activate. If the impeller's rotation is difficult or completely resistant, contact the Liberty Pumps Customer Service Department.

### 3-2 STORAGE BEFORE USE

Liberty pumps are shipped from the factory ready for installation and use. They should be held in storage if the pump station is not complete. If storage is necessary, the pump should remain in its shipping container. It should be stored in a warehouse or storage shed that has a clean, dry temperature-stable area where the pump and its container should be covered to protect it from water, dirt, dust, etc. The ends of the cables - (plugs) must be protected against moisture.

**⚠ CAUTION** AT NO TIME SHOULD THE PUMP BE STORED WITHIN AN INCOMPLETE WET PIT. THE PUMP SHOULD NOT BE PLACED INTO THE PIT UNTIL IT CAN BE FULLY OPERATED.

#### LONG TERM STORAGE

1. If it is necessary to store a pump for a long period of time, it should be stored indoors in a clean, dry temperature-stable environment. The pump should be covered to protect it from dust, dirt and water. The plug end of the cable must be protected against moisture.
2. Do not allow the pump to freeze.
3. Prior to installation, the pump motor should be rotated to ensure the seals and cutters are free spinning.
4. Installed pumps which are idle for long periods of time should be manually operated through the breaker panel once a month to lubricate the seals. Turn off the breaker, unplug the piggyback switch, and plug the pump directly into the wall socket. Turn the breaker on for 30 seconds. Turn the breaker off, and then plug the piggyback switch back in. (refer to Section 4-1)

### 3-3 PUMP INSTALLATION

**⚠ WARNING** THIS PUMP IS NOT TO BE INSTALLED IN LOCATIONS CLASSIFIED AS HAZARDOUS IN ACCORDANCE WITH THE NATIONAL ELECTRICAL CODE, ANSI/NFPA 70.

- Grinder pumps must be installed in a tank that is vented in accordance with local plumbing codes. Installation should be at a sufficient depth to ensure that all plumbing is below the frost line. If this is not feasible, remove the check valve and size the basin and/or adjust pump differential to accommodate the additional backflow volume. Consult the factory for details on how this should be done.

The Omnivore Grinders may be guide rail mounted using Liberty's GR20 guide rail base, or stand-alone. (See **Figure 3, page 11**) They may be installed as a completely packaged simplex (single pump) or duplex (two-pump) system. Installation of the pump shall be in accordance with state and local codes and performed only by qualified personnel. Typical installations consist of a guide rail mount in a fiberglass, concrete or polyethylene tank. This section assumes guide rail installation.

**⚠ CAUTION** NEVER LIFT THE PUMP BY PULLING ON THE POWER CORD. USE THE LIFTING CHAIN OR CABLE ONLY

1. Liberty GR20 Guide Rail systems feature a self-aligning mounting bracket. Using the lifting chain, slip the pump bracket over the upper guide rail bracket. Lower the pump at an angle down the guide rail into the tank. (See **Figure 3, page 11**)
2. As the pump nears its final position, the straightening rib squares the pump bracket with the guide bracket ears. When the pump bracket ears hook the guide bracket ears, the chain will slacken.
3. Grasp the lifting chain and shake the pump to ensure a good seat with the gasket. The pump is suspended by the bracket ears. The weight of the pump compresses the gasket against the mating flange of the guide bracket base.
4. The lifting chain may be removed from the hoist and hooked near the upper guide rail bracket.



**IMPORTANT:** For 3-phase pumps, check for proper rotation before installing pump into basin. See figure A for proper rotation.

**Fig. A – Proper impeller rotation, three phase models**



Check three phase pumps for proper rotation prior to installing pump(s) in basin. To change rotation, reverse any two of the three power leads to the pump. Code the wires for reconnection after installation.

## 4. Electrical Connection

**AFTER THE PUMP IS INSTALLED, THE ELECTRICAL CHECKS OF SECTION 4 MUST BE PERFORMED.**



### 4-1 PIGGY BACK SWITCH OPERATION

1. Plug the Piggyback switch into a 6-20R receptacle. The receptacle must be wired to a 30-amp breaker. Be sure to have the breaker turned off before plugging in the switch.
2. Plug the pump power cord into the piggyback switch as shown.
3. The pump is ready to test and your breaker can be turned on. (Refer to section 5)

**PIGGY BACK PLUG INSTALLATION**

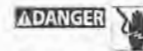

**ENSURE THAT POWER IS OFF AT BREAKER BEFORE PLUGGING OR UNPLUGGING !**



**ALWAYS TURN OFF BREAKERS BEFORE WORKING ON ELECTRICAL CORDS. BE CAREFUL NOT TO DRILL OR SCREW INTO EXISTING WIRING.**

Check to make sure installation is in accordance with the National Electric Code and all applicable local codes. Installation and servicing is to be conducted by qualified personnel. This pump is supplied with a grounding conductor. To reduce the risk of electrical shock, be certain that it is connected to a properly grounded earth wire.

### 4-2 DIRECT WIRING OF AUTOMATIC PUMP

The pump can run on a voltage rating of 230V or 208V. Check that it is the same as the supply voltage. The pumps are supplied with 6-20P (20-amp) cord plug ends. If a single phase pump is to be wired directly into a control device or junction box, and it is necessary to remove the plugs, have a certified electrician do the wiring in accordance with the National Electric Code and applicable local codes. See Fig. B for direct wire installation of single phase, automatic pumps.

1. The control panel is preferably mounted in a cool, dry environment. Installation and connections are specific to the control panel. Control panels should be installed and serviced only by a qualified electrician (Refer to Figure 2, page 10).

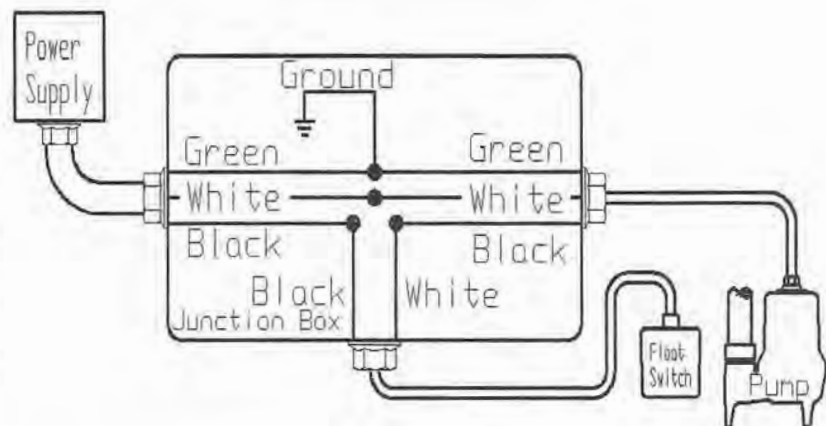

**Fig. B – Direct Wiring of 120V or 208-230V Single Phase, Automatic Pumps**

### 4-3 CONTROL PANEL OPERATION

#### **⚠ WARNING**

REFER TO WIRING DIAGRAM INCLUDED WITH CONTROL PANEL. IF THERE IS NO WIRING DIAGRAM, CONTACT THE MANUFACTURER TO OBTAIN ONE. DO NOT ATTEMPT TO CONNECT PUMP WITHOUT A WIRING DIAGRAM.

### 4-4 EXTERNAL CAPACITORS

The LSG202M-C and LSGX202M-C (208-230V SINGLE PHASE UNITS) are designed such that the capacitors and start relay are mounted in a control panel external from the pump. The most basic wiring diagram is illustrated in Figure C. Increased functionality of the panel like simplex or duplex pump control would complicate the wire schematic. Before connecting the pump consult the schematic for the specific panel or contact the panel manufacturer.

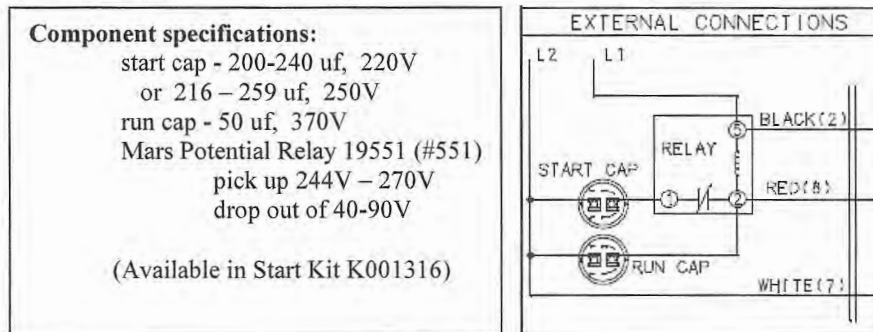

Figure C

### 4-5 STEPS TO BE TAKEN BEFORE ENERGIZING

1. Retighten all field-made connections. Retighten all factory-made connections. These may have loosened due to shipping and handling vibrations.
2. Check the security of mounting hardware.
3. Check the enclosure to see that it has not been damaged in such a manner as to reduce electrical spacing.
4. Rotate the cutter wheel with the hex socket head cap screw to verify movement and lubricate the seals.
5. Ensure that no wires or other obstacles are in the way of the pump cutter.
6. Conduct an electrical insulation resistance test to make sure that the control panel is free from short circuits and ground faults. This should be done both phase-to-phase and phase-to-ground.
7. **MOTOR OVERLOAD PROTECTION:** The pump motor is protected from locked rotor and running overloads by a thermal overload integrally mounted to the motor (Single Phase Only). No adjustments are required.
8. Check to determine that all grounding connections are made properly
9. If a panel is used, remove all debris, scrap wire, etc., from the control panel interior before closing the doors. Install covers, close doors making certain that no wires are pinched and that all enclosure parts are properly aligned and tightened.

#### **⚠ WARNING**

**ENERGIZING THE CONTROL PANEL OR BREAKER FOR THE FIRST TIME IS POTENTIALLY DANGEROUS. LICENSED ELECTRICAL PERSONNEL SHOULD BE PRESENT WHEN THE PANEL OR BREAKER IS ENERGIZED FOR THE FIRST TIME. IF FAULTS CAUSED BY DAMAGE OR POOR INSTALLATION PRACTICES HAVE NOT BEEN DETECTED, SERIOUS DAMAGE CAN RESULT WHEN POWER IS APPLIED (REFER TO SECTION 5).**

### 4-6 FLOAT SWITCHES

1. The pump's on and off cycles are normally controlled by a "piggy back" float switch attached to the side of the pump, or by hanging switches in the wet well. Refer to panel or switch instructions for proper electrical connection



#### **4-6.1 FLOAT SEQUENCE- PIGGY BACK (AUTOMATIC MODELS LSG202A & LSGX202A)**

1. As the liquid level in the wet well rises, the float tilts, closing the switch. This starts the pump.
2. The pump runs until the liquid level falls below the "PUMP OFF" level of the float (Factory set at 7" minimum), emptying the wet well.

#### **4-6.2 FLOAT SEQUENCE- SIMPLEX (MANUAL MODELS)**

1. As the liquid level in the wet well rises, the "PUMP OFF" float tilts, closing the switch (This level must be set at a minimum of 7"). As the liquid level continues to rise, the "PUMP ON" float tilts. This switch closes, starting the pump.
2. The pump runs until the liquid level falls below the "PUMP OFF" float, emptying the wet well.
3. In the event of a malfunctioning float switch, control relay or pump, the liquid level rises and tilts the "HIGH LEVEL ALARM" float. The alarm system will activate.

#### **4-6.3 FLOAT SEQUENCE-DUPLEX (MANUAL MODELS)**

1. As the liquid level in the wet well rises, the "PUMP OFF" tilts, closing the switch. As the liquid level continues to rise, the "LEAD PUMP ON" float tilts. This switch closes, starting the lead pump. The pump runs until the liquid level falls below the "PUMP OFF" float, emptying the wet well.
2. On the next rise of the liquid level, the other pump will start on the "LEAD PUMP ON" signal. The pumps will continue to alternate their cycles.

**NOTE: The ON/OFF float switch differential should be set as to not exceed 12 starts per hour.**

3. If the liquid level rises to the "LAG PUMP ON" float, the second pump will start. Both pumps will run until the liquid falls below the "PUMP OFF" float, emptying the wet well.
4. In the event of a malfunctioning float switch, control relay or pump, the liquid level rises and tilts the "HIGH LEVEL ALARM" float. The alarm system will activate.

#### **4-6.4 FLOAT SWITCH INSTALLATION**

The engineering drawings will normally specify the levels for pump start and stop and high level alarm. If they are not specified, these guidelines should be used to determine float switch locations.

##### **PIGGY BACK SWITCH**

(1-Float System)

Pump Off: Factory set. (Float tether 4")

Pump On: Factory set. (Float tether 4")

##### **SIMPLEX PUMP STATION**

(3-Float System)

Pump Off: Level to top of motor housing.

Pump On: Minimum 1-1/2 ft. above Pump Off Level.

High Level Alarm: Minimum 1 ft. above pump ON level. Below influent pipe.

##### **DUPLEX PUMP STATION**

(4-Float System)

Pump Off: Level to top of motor housing.

Lead Pump On: Minimum 1-1/2 ft. above Pump Off level.

Lag Pump On: Minimum 1 ft. above Lead Pump On level.

High Level Alarm: Minimum 1 ft. above Lag Pump On level. Below influent pipe.

# 5. Operation

## 5-1 OPERATION

After the electrical and mechanical installations have been performed, the pump is ready for operation. No operational procedures are required except to apply rated power to the pump. There are no specific shutdown procedures beyond disconnecting the power supply.

### **⚠ CAUTION**

**IF THE ROTATION OF A SINGLE PHASE PUMP IS INCORRECT, NOTIFY THE LIBERTY PRODUCT SERVICE DEPARTMENT IMMEDIATELY. DO NOT SWITCH THE POWER SUPPLY LEADS. DO NOT OPERATE THE PUMP.**

### **⚠ WARNING**

**ALWAYS ENSURE THAT THE PUMP IS FREE OF WIRES OR OTHER OBSTRUCTIONS THAT MAY CAUSE HARM OR INJURY.**

## 5-2 PERIODIC MAINTENANCE & LUBRICATION

Liberty pumps are designed for long lasting, efficient and reliable service with a minimum of preventive maintenance checks. These checks are few but will add years of satisfactory service to the life of the pump. Maintenance checks should be performed at the intervals stated. Severe operating environments will require more frequent checks.

## 5-3 LUBRICATION

Pump is permanently lubricated and cooled by turbine oil. If replacement oil is required, use ISO-32 turbine oil. If this is unavailable a full synthetic SAE 5W-30 or 5W-20 motor oil may be used. Capacity .8 gallons.

**TROUBLESHOOTING CHART: LSG200**

<u>SYMPTOM</u>	<u>POSSIBLE CAUSE</u>	<u>ACTION</u>
1. PUMP WILL NOT START	<p>A. Power supply failure</p> <p>B. Burned out fuse or tripped circuit breaker</p> <p>C. Damaged power cable</p> <p>D. Jammed impeller</p> <p>E. Water inside motor</p>	<p>A. Check power supply Check out electrical system for loose connections Check operating voltage</p> <p>B. Check circuit protectors</p> <p>C. Check external cable for damage – repair</p> <p>D. Inspect and remove jamming object</p> <p>E. Refer to Symptom 5 and 6</p>
2. REPEATED TRIPPING	<p>A. Circuit protection under-rated</p> <p>B. Current unbalance</p> <p>C. Pump connected to incorrect voltage</p> <p>D. Wet or damaged wiring</p> <p>E. Obstruction in pump</p> <p>F. Incorrect motor rotation</p> <p>G. Foreign matter build-up</p>	<p>A. Check rating and replace with proper size</p> <p>B. Check current draw</p> <p>C. Verify connections. See wiring diagram</p> <p>D. Inspect external cable, replace if worn or damaged</p> <p>E. Remove obstruction</p> <p>F. Check rotation</p>
3. PUMP WILL NOT SHUT OFF	<p>A. Control panel failure</p> <p>B. Switch Failure</p>	<p>A. Clean motor housing</p> <p>B. Check control panel</p> <p>C. B. Replace the switch</p>
4. LOW FLOW	<p>A. Incorrect pump rotation</p> <p>B. Low liquid level</p> <p>C. Obstruction in pump or piping</p> <p>D. Partially closed valve(s)</p>	<p>A. Check rotation</p> <p>B. Check liquid level</p> <p>C. Remove obstruction</p> <p>D. Check and adjust valve</p>
5. WATER IN OIL CHAMBER	<p>A. Loose or damaged oil plug</p>	<p>A. Check plug and sealing washer</p>
6. WATER INSIDE MOTOR CASING	<p>A. Damaged lower lip seal or mechanical seal</p> <p>B. Damaged O-Ring between oil chamber and motor plate</p> <p>C. Damaged cable</p>	<p>A. Replace seal</p> <p>B. Replace O-Ring</p> <p>C. Replace cable</p>

IF SYMPTOMS CONTINUE, CONSULT THE LIBERTY PUMPS PRODUCT SERVICE DEPT.

FIGURE 2 CONTROL PANEL INSTALLATION

# CONTROL PANEL INSTALLATION INSTRUCTIONS

**⚠ WARNING**



**ELECTRICAL SHOCK HAZARD**

Disconnect all power sources before servicing. Failure to do so could result in serious injury or death.

This control panel must be installed by a LICENSED ELECTRICIAN and in accordance with the National Electric Code NFPA-70, and state and local codes.

All conduit running from the sump or tank to the control panel must be sealed with conduit sealant to prevent moisture or gases from entering the control panel. **NEMA 1 enclosures are for indoor use** primarily to provide a degree of protection against contact with enclosed equipment. Cable connectors are not required to be liquid tight on NEMA 1 enclosures. **Do not use NEMA 1 enclosures if subjected to rain, splashing water, or hose-directed water.** **NEMA 4X enclosures are for indoor or outdoor use** primarily to provide a degree of protection against corrosion, windblown dust and rain, splashing water, and hose-directed water. **Cable and conduit connectors must be liquid tight on NEMA 4X enclosures.**

## Mounting and Wiring the Control Panel

1. Determine the mounting location for the control panel. If distance exceeds the length of either the control switch cables or the pump power cables, splicing will be required. For an outdoor or a wet installation we recommend the use of a junction box with liquid tight connectors to make required connections. You must use conduit sealant to prevent moisture or gases from entering the panel.
2. Mount the control panel (mounting devices are furnished with control panel).
3. Determine the conduit entrance locations on the control panel. Check local codes and schematic for power circuit requirements.

**CAUTION: BE SURE THE POWER SUPPLY VOLTAGE AND PHASE ARE THE SAME AS THE PUMP MOTORS BEING INSTALLED. IF IN DOUBT, SEE THE PUMP IDENTIFICATION PLATE FOR VOLTAGE/PHASE REQUIREMENTS.**

4. Drill proper size holes for connection to the panel.  
**CAUTION: IF USING CONDUIT, BE SURE THAT THE CONDUIT BEING USED IS OF ADEQUATE SIZE TO PULL THE PUMP AND SWITCH CABLES THROUGH. RECOMMENDED MINIMUM 1 1/2" FOR DUPLEX APPLICATIONS.**
5. Attach cable connectors and/or conduit connectors to the control panel.  
**CAUTION: AT THIS POINT, TURN OFF ALL POWER SOURCES.**

*FOR INSTALLATIONS WITHOUT A SPLICE, GO TO STEP 11.  
FOR INSTALLATIONS REQUIRING A SPLICE, FOLLOW STEPS 6-10.*

6. Determine the location for mounting the junction box according to local code requirements. **Do not** mount the junction box inside the sump or basin.
7. Run the conduit or connectors to junction box and drill the junction box as required to make the proper connections. Attach the conduit or connectors to the junction box.
8. Mount junction box to proper support.
9. Identify and label each wire before pulling through conduit into junction box. Make necessary wire splice connections at the junction box.
10. Firmly tighten all fittings on the junction box.
11. Pull pump cables and control switch cables through connectors/conduit into the control panel.
12. Connect pump cables and control switch cables to the appropriate terminals. SEE SCHEMATIC INSIDE CONTROL PANEL.

**CAUTION: IF CONTROL SWITCH CABLES ARE NOT WIRED IN THE CORRECT ORDER, THE PUMP SYSTEM WILL NOT FUNCTION PROPERLY.**

13. Connect "power in" conductors to proper terminals. SEE SCHEMATIC.
14. Verify the correct operation of the control panel after installation is complete.

©SJE-Rhombus  
1005370C  
9/00



FIGURE 3 TYPICAL INSTALLATION



WITHOUT GUIDE RAIL

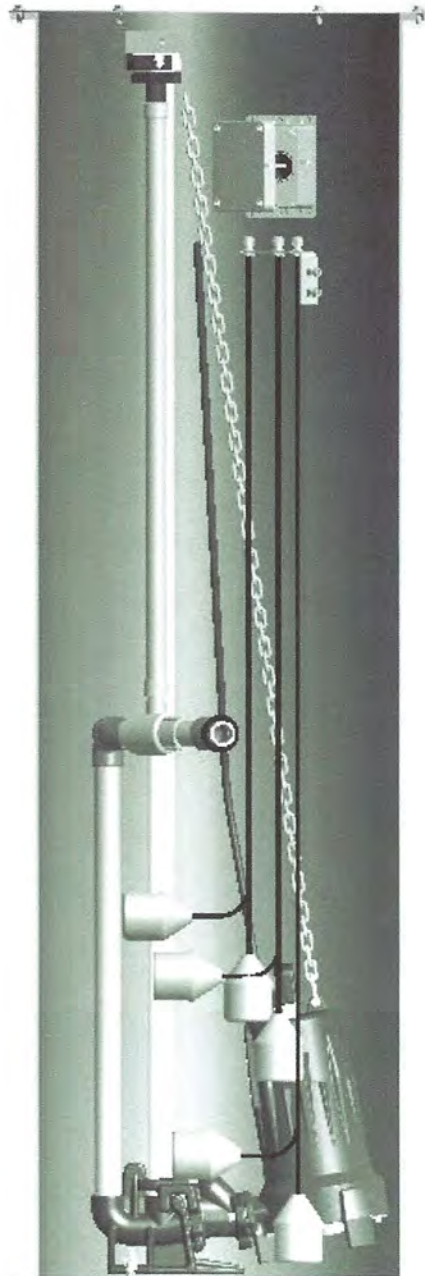

WITH GR20 GUIDE RAIL

# PERFORMANCE CURVE Omnivore Grinders

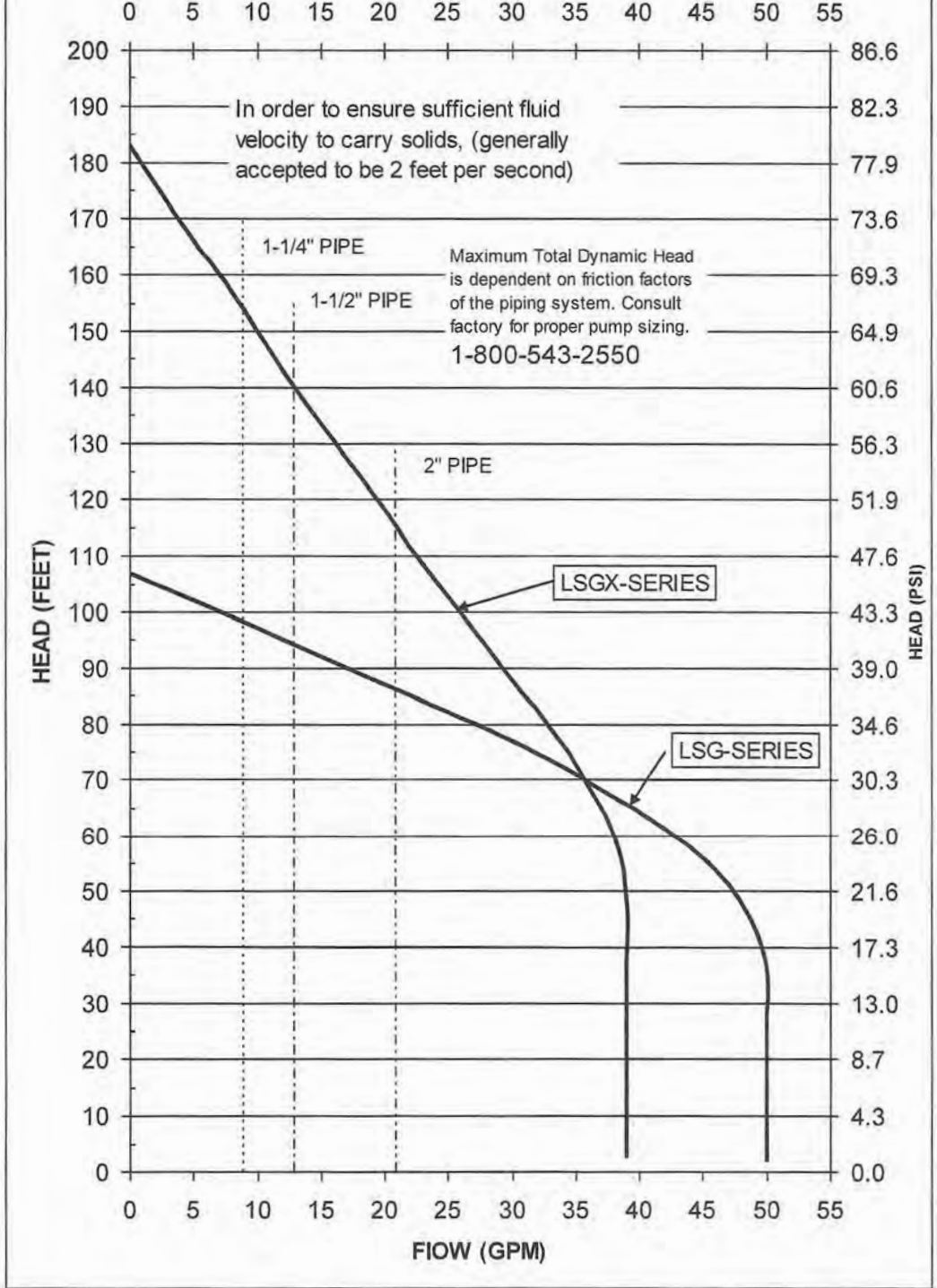

## 6. **3 Year Limited Warranty**

Liberty Pumps, Inc. warrants that pumps of its manufacture are free from all factory defects in material and workmanship for a period of 3 years from the date of purchase. The date of purchase shall be determined by a dated sales receipt noting the model and serial number of the pump. The dated sales receipt must accompany the returned pump if the date of return is more than 3 years from the "CODE" (date of manufacture) number noted on the pump nameplate.

The manufacturer's obligation under this Warranty shall be limited to the repair or replacement of any parts found by the manufacturer to be defective, provided the part or assembly is returned freight prepaid to the manufacturer or its authorized service center, and provided that none of the following warranty-voiding characteristics are evident.

The manufacturer shall not be liable under this Warranty if the product has not been properly installed; if it has been disassembled, modified, abused or tampered with; if the electrical cord has been cut, damaged or spliced; if the pump discharge has been reduced in size; if the pump has been used in water temperatures above the advertised rating, or water containing sand, lime, cement, gravel or other abrasives; if the product has been used to pump chemicals or hydrocarbons; if a non-submersible motor has been subjected to excessive moisture; or if the label bearing the serial, model and code number has been removed. Liberty Pumps, Inc. shall not be liable for any loss, damage or expenses resulting from installation or use of its products, or for consequential damages, including costs of removal, reinstallation or transportation.

There is no other express warranty. All implied warranties, including those of merchantability and fitness for a particular purpose, are limited to three years from the date of purchase.

This Warranty contains the exclusive remedy of the purchaser, and, where permitted, liability for consequential or incidental damages under any and all warranties are excluded.



7000 Apple Tree Avenue  
Bergen, NY 14416  
Phone: (800) 543-2550  
Fax: (585) 494-1839  
[www.libertypumps.com](http://www.libertypumps.com)





## INSTALLATION MANUAL

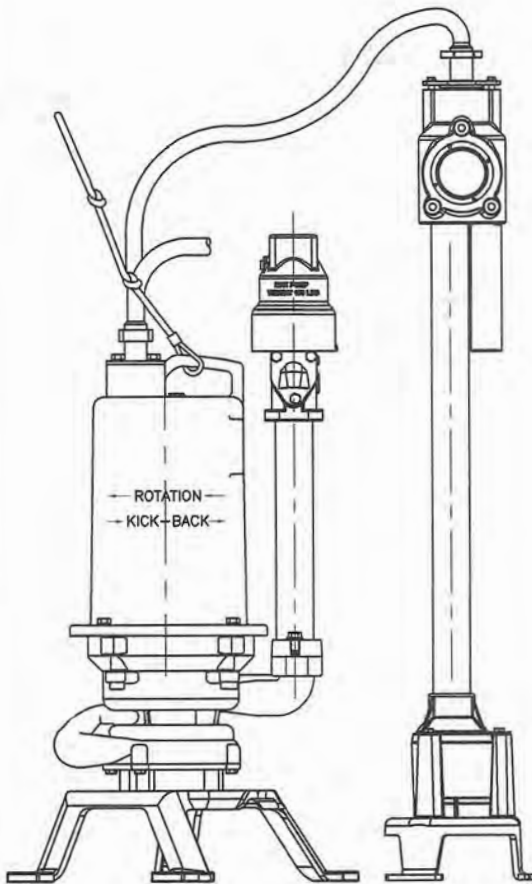

## 1.25" NPT Universal Upgrade Core

Series: OGP2022AUE  
OGT1022AUE

# Upgrade Core

**omni**  
**GRIND**<sup>TM</sup> *plus*<sup>+</sup>  
GRINDER PUMPS

### IMPORTANT!

*Read all instructions in this manual before operating pump.  
As a result of Crane Pumps & Systems, Inc., constant product improvement program,  
product changes may occur. As such Crane Pumps & Systems reserves the right to  
change product without prior written notification.*

**CRANE**

A Crane Co. Company

PUMPS & SYSTEMS

420 Third Street  
Piqua, Ohio 45356  
Phone: (937) 778-8947  
Fax: (937) 773-7157  
www.cranepumps.com

83 West Drive, Bramton  
Ontario, Canada L6T 2J6  
Phone: (905) 457-6223  
Fax: (905) 457-2650



Form No. 118951A-Rev. F



## TABLE OF CONTENT

SAFETY FIRST .....	3
USER GUIDE .....	4
SPECIFICATIONS .....	5 - 6
INSTALLATION .....	7 - 15
ELECTRICAL CONNECTIONS .....	8
EXPLODED VIEW (FIG. 9) .....	16
PARTS LIST .....	17
EXPLODED VIEW (FIG. 10) .....	18
PARTS LIST .....	19
WARRRANTY .....	21
REGISTRATION .....	22
RETURNED GOODS POLICY .....	22
START-UP REPORT .....	23 - 24

Other brand and product names are trademarks or registered trademarks of their respective holders.

® Barnes is a registered trademark of Crane Pumps & Systems, Inc

© Crane Pumps & Systems, Inc. 2003, 2/2006, 9/06

Alteration Rights Reserved

# SAFETY FIRST!

Please Read This Before Installing Or Operating Pump. This information is provided for **SAFETY and to PREVENT EQUIPMENT PROBLEMS**. To help recognize this information, observe the following symbols:



**IMPORTANT!** Warns about hazards that can result in personal injury or indicates factors concerned with assembly, installation, operation, or maintenance which could result in damage to the machine or equipment if ignored.

**CAUTION !** Warns about hazards that can or will cause minor personal injury or property damage if ignored. Used with symbols below.

**WARNING !** Warns about hazards that can or will cause serious personal injury, death, or major property damage if ignored. Used with symbols below.



*Hazardous fluids can cause fire or explosions, burns or death could result.*



*Hazardous voltage can shock, burn or cause death.*



*Biohazard can cause serious personal injury.*



*Rotating machinery Amputation or severe laceration can result.*

Only qualified personnel should install, operate and repair pump. Any wiring of pumps should be performed by a qualified electrician.



**DO NOT** drop or roll basin. This will damage unit and void the warranty.

Minimize the amount of cooking grease entering the system.

**DO NOT** leave pump cover off the basin, except while servicing, to prevent entrance of foreign materials such as rocks, metal, soil, animals or humans.

Prevent infiltration or direct flow of rain or run-off water into the pump basin to minimize pump cycling. This will prevent overloading the treatment facility, and will facilitate swift transportation of sewage.



To reduce risk of electrical shock, pumps and control panels must be properly grounded in accordance with the National Electric Code (NEC) or the Canadian Electrical Code (CEC) and all applicable state, province, local codes and ordinances.

To reduce risk of electrical shock, always disconnect the pump from the power source before handling or servicing. Lock out power and tag.

**CAUTION** - This unit may have more than one connection to the source of supply. To reduce the risk of electric shock, disconnect all such connections before servicing.

All connections inside this tank and/or junction box must be made with listed, watertight connectors.

This basin system is intended for use with water, sewage and effluent applications. This basin must be vented in accordance with local codes. This basin system is not to be installed in locations in which the basin interior would be classified as a

hazardous location in accordance with NEC ANSI/NPFA 70.

Prevent large articles of clothing, large amounts of chemicals, other materials or substances such as are uncommon in domestic sewage from entering the system.

During power black-outs, minimize water consumption at the home(s) to prevent sewage from backing up into the house.

Always keep the shut-off valve completely open when system is in operation (unless advised otherwise by the proper authorities). Before removing the pump from the basin, be sure to close the shut-off valve. (This prevents backflow from the pressure sewer.)

Keep the control panel locked or confined to prevent unauthorized access to it.

If the pump is idle for long periods of time, it is advisable to start the pump occasionally by adding water to the basin.



**WARNING!** Do not pump hazardous materials (flammable, caustic, etc.) unless the pump is specifically designed and designated to handle them.



**DO NOT** wear loose clothing that may become entangled in the impeller or other moving parts.

Keep clear of suction and discharge openings.

**DO NOT** insert fingers in pump with power connected.



Always wear appropriate safety gear, such as safety glasses, when working on the pump or piping.



Cable should be protected at all times to avoid punctures, cut, bruises and abrasions - inspect frequently.



Never handle connected power cords with wet hands.



To reduce risk of electrical shock, all wiring and junction connections should be made per the NEC or CEC and applicable state or province and local codes. Requirements may vary depending on usage and location.



Products Returned Must Be Cleaned, Sanitized, Or Decontaminated As Necessary Prior To Shipment, To Insure That Employees Will Not Be Exposed To Health Hazards In Handling Said Material. All Applicable Laws And Regulations Shall Apply.



Bronze/brass and bronze/brass fitted pumps may contain lead levels higher than considered safe for potable water systems. Lead is known to cause cancer and birth defects or other reproductive harm. Various government agencies have determined that leaded copper alloys should not be used in potable water applications. For non-leaded copper alloy materials of construction, please contact factory.



**IMPORTANT!** - Crane Pumps & Systems, Inc. is not responsible for losses, injury, or death resulting from a failure to observe these safety precautions, misuse or abuse of pumps or equipment.

Other brand and product names are trademarks or registered trademarks of their respective holders.

© Barnes is a registered trademark of Crane Pumps & Systems, Inc

© Crane Pumps & Systems, Inc. 2001, 2002, 9/05, 5/06

Alteration Rights Reserved



**USER GUIDE**

Congratulations on your purchase of a Barnes *UltraGRIND™* grinder pump system. With proper care and by following a few simple guidelines your grinder pump will give you many years of dependable service.

**Use and Care**

The *UltraGRIND* grinder pump station is designed to handle routine, domestic sewage. Solid waste materials should be thrown in the trash. While your station is capable of accepting and pumping a wide range of materials, regulatory agencies advise that the following items should not be introduced into any sewer either directly or through a kitchen waste disposal:

- Glass
- Metal
- Diapers
- Socks, rags or cloth
- Plastic objects (e.g., toys, utensils, etc.)
- Sanitary napkins or tampons

In addition you must **NEVER** introduce into any sewer:

- Explosives
- Flammable Material
- Lubricating Oil and/or Grease
- Strong Chemicals
- Gasoline

**General Information**

Your home wastewater disposal service is part of a low pressure sewer system. The key element in this system is the Barnes *UltraGRIND* grinder pump station. The basin collects all wastewater from the house. The solids in the sewage are then ground to a small size suitable for pumping in the slurry.

**GRINDER PUMP SYSTEMS**

The grinder pump generates sufficient pressure to pump this slurry from your home to the wastewater plant.

**Power Failure**

Your grinder pump cannot dispose of wastewater or provide an alarm signal without electrical power. If electrical power service is interrupted, keep water usage to a minimum.

**Warranty**

Your grinder pump is furnished with a warranty against defects in material or workmanship. A properly completed Start-Up/Warranty Registration form must be on file at the Barnes factory in order to activate your warranty. In addition your pump must be installed in accordance with the installation instructions.

If you have a claim under the provisions of the warranty, contact your local Barnes Distributor.

When contacting your representative for service, please include your station serial number, pump model number, and pump serial number.

For future reference, record the following information:

Station Serial No: \_\_\_\_\_

Pump Model No: \_\_\_\_\_

Pump Serial No: \_\_\_\_\_

Local Distributor: \_\_\_\_\_

Distributor Telephone: \_\_\_\_\_





## PUMP SPECIFICATIONS: OGP2022AUE

**DISCHARGE** ..... 1½" NPT Vertical, Bolt-on Flange  
**LIQUID TEMPERATURE** .... 104°F (40°C) Continuous  
**MOTOR HOUSING** ..... Cast Iron ASTM A-48, Class 30  
**VOLUTE** ..... Cast Iron ASTM A-48, Class 30  
**SEAL PLATE** ..... Cast Iron ASTM A-48, Class 30  
**IMPELLERS**  
     *Design* ..... 12 vane, vortex, with pump out vanes on back side. Dynamically balanced, ISO G6.3  
     *Material* ..... 85-5-5-5 Bronze (Std) or Cast Iron ASTM A-48, Class 30  
**SHREDDING RING** ..... Hardened 440C Stainless Steel Rockwell® C-55  
**CUTTER** ..... Hardened 440C Stainless Steel Rockwell® C-55  
**SHAFT** ..... 416 Stainless Steel  
**SQUARE RING** ..... Buna-N  
**HARDWARE** ..... 300 Series Stainless Steel  
**PAINT** ..... Air dry enamel, top coat  
**SEAL**     *Design* ..... Single Mechanical, oil filled reservoir  
           *Material* ..... Rotating Faces - Silicon-Carbide  
                               Stationary Faces - Silicon-Carbide  
                               Elastomer - Buna-N  
                               Hardware - 300 series stainless steel  
**CORD ENTRY** ..... 15 Ft. (4.5M) Cord, Custom Molded Quick Connected for sealing and strain relief

**CORD** ..... CSA/UL Approved 12/5, Type SOW  
**SPEED** ..... 3450 RPM, 60Hz  
**UPPER BEARING:**  
     *Design* ..... Single Row, Angular Contact Ball  
     *Lubrication* ..... Oil  
     *Load* ..... Radial & Thrust  
**LOWER BEARING**  
     *Design* ..... Single Row, Angular Contact Ball  
     *Lubrication* ..... Oil  
     *Load* ..... Radia & Thrust  
**MOTOR**     *Design* ..... NEMA L, Oil Filled, Squirrel Cage Induction  
                   *Insulation* ..... Class F  
**SINGLE PHASE** ..... Capacitor start/capacitor run  
**STAND** ..... Painted Cast Iron with rubber feet, Stainless Steel Hardware  
**LEVEL CONTROL** ..... Model ESPS-150, Environmentally sealed pressure switch with CPVC housing, Buna diaphragm, Custom Molded Quick Connect for Sealing and Strain Relief  
**CHECK VALVE:**  
     *Body* ..... Cast Iron ASTM A-48, Class 30  
     *Seat* ..... Bronze ASTM C836  
     *Flap* ..... Fiber Reinforced Buna

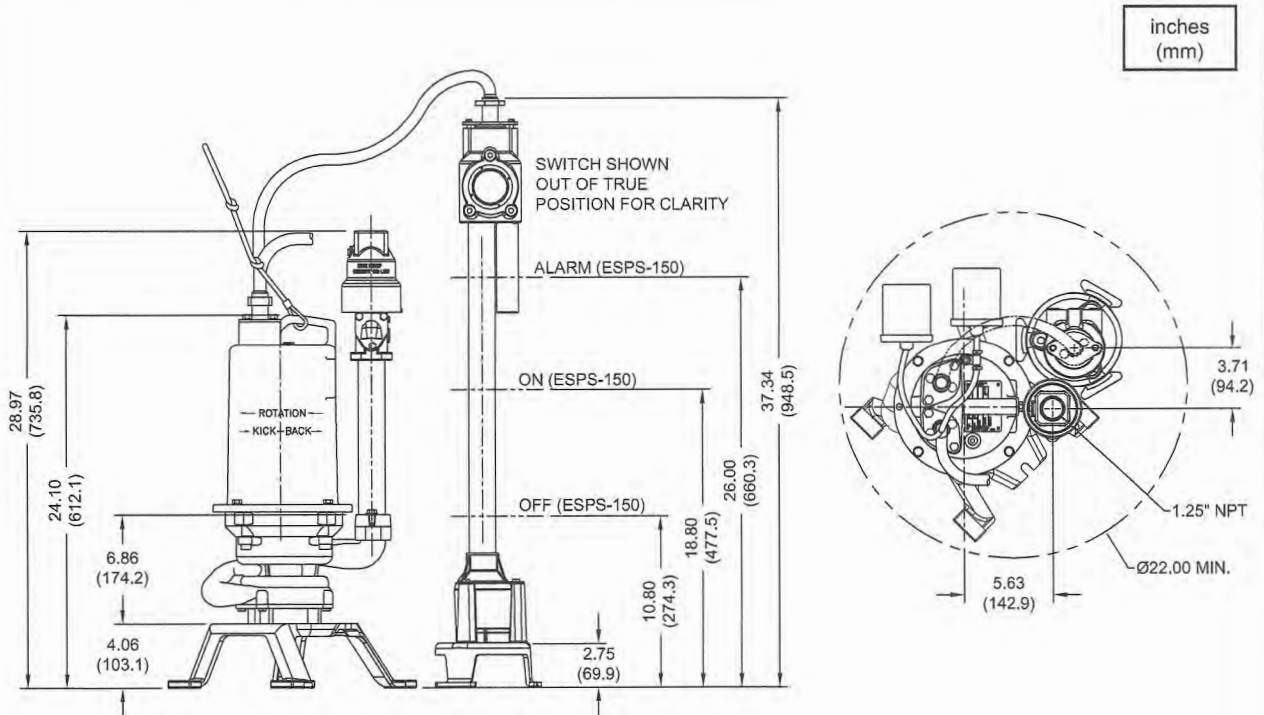

## PUMP SPECIFICATIONS: OGT1022AUE

<b>DISCHARGE</b> .....	1 1/4" NPT Vertical
<b>LIQUID TEMPERATURE</b> ....	≤40°C Continuous
<b>MOTOR HOUSING</b> .....	Cast Iron ASTM A-48, Class 30
<b>VOLUTE</b> .....	Cast Iron ASTM A-48, Class 30
<b>SEAL PLATE</b> .....	Cast Iron ASTM A-48, Class 30
<b>IMPELLER</b> .....	Stainless Steel
<b>SHREDDING RING</b> .....	Hardened 440C Stainless Steel Rockwell® C-55
<b>CUTTER</b> .....	Hardened 440C Stainless Steel Rockwell® C-55
<b>SHAFT</b> .....	416 Stainless Steel
<b>SQUARE RING</b> .....	Buna-N
<b>HARDWARE</b> .....	300 Series Stainless Steel
<b>PAINT</b> .....	Air Dry Enamel
<b>SEAL</b>	<i>Design</i> ..... Single Mechanical, oil filled reservoir
	<i>Material</i> ..... Rotating Faces - Silicon-Carbide Stationary Faces - Silicon-Carbide Elastomer - Buna-N
<b>CORD ENTRY</b> .....	Hardware - 300 series stainless steel
<b>CORD</b> .....	Custom Molded, Quick Connected for sealing and strain relief
<b>CORD</b> .....	CSA/UL Approved 12/5 Automatic Pumps Type SOW
<b>SPEED</b> .....	3450 RPM, 60Hz

### UPPER BEARING:

*Design*..... Single Row, Angular Contact Ball  
*Lubrication* ..... Oil  
*Load*..... Radial & Thrust

### LOWER BEARING

*Design*..... Single Row, Angular Contact Ball  
*Lubrication* ..... Oil  
*Load*..... Radial & Thrust

### MOTOR

*Design*..... NEMA L, Oil Filled,  
Squirrel Cage Induction  
*Insulation* ..... Class F

### SINGLE PHASE

Capacitor start/capacitor run

### LEVEL CONTROLS:

Model ESPS-150™, Environmentally sealed pressure switch with CPVC housing, Buna diaphragm, Custom Molded Quick Connect for Sealing and Strain Relief

### CHECK VALVE:

*Body*..... Cast Iron ASTM A-48, Class 30  
*Seat* ..... Bronze ASTM C836  
*Flap*..... Fiber Reinforced Buna

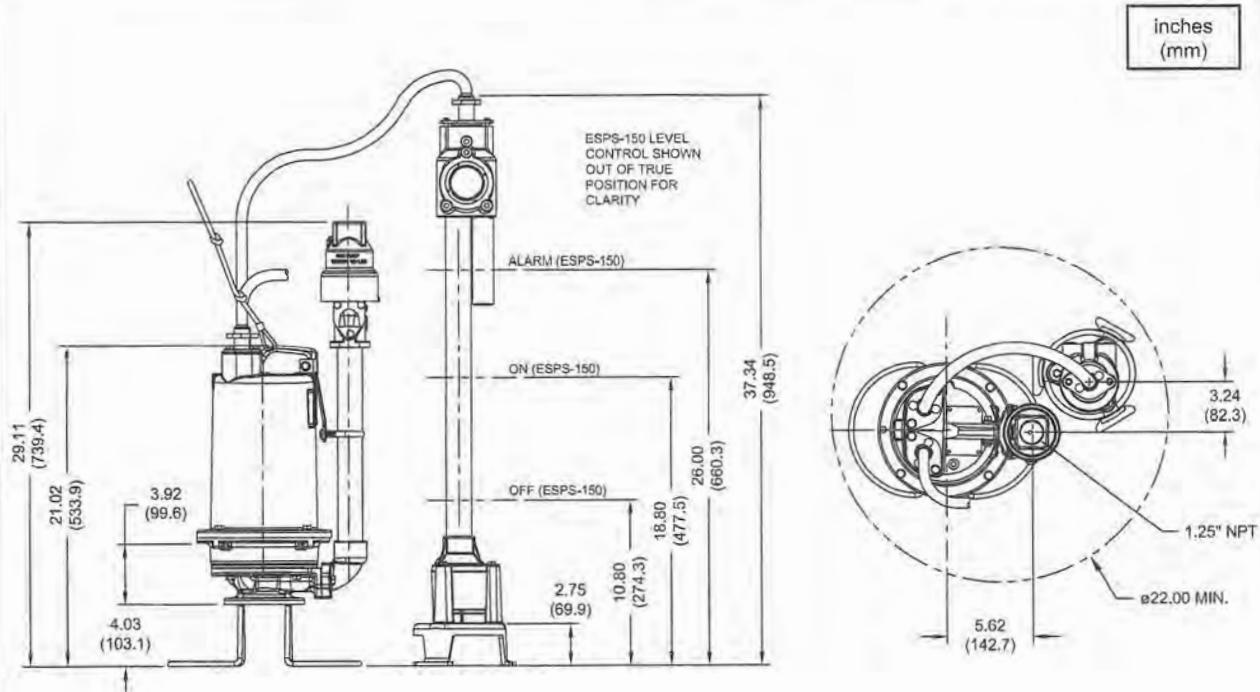

### BEFORE YOU BEGIN

- Read this manual completely before starting your installation
- Consult local officials for any applicable codes and regulations.
- Make sure you have the necessary equipment and supplies before starting your installation (see tool and material lists).

### TOOL AND MATERIAL LIST (NOT INCLUDED)

- SAE Socket Set
- Ratchet
- Tape Measure
- Wire Strippers (12 AWG to 18 AWG)
- Wire Cutters
- Multi-Meter
- Cable Lube
- Small Slotted Screw Driver
- Combination Wrenches, SAE

### RECEIVING/UNPACKING:

Upon receiving the pump, it should be inspected for damage or shortages. If damage has occurred, file a claim immediately with the company that delivered the pump. Unpack pump and record pump serial and model number before installing. If the manual is removed from the packaging, do not lose or misplace.

### STORAGE:

**Short Term-** For best results, pumps can be retained in storage, as factory assembled, in a dry atmosphere with constant temperatures for up to six (6) months.

**Long Term-** Any length of time exceeding six (6) months, but not more than twenty-four (24) months. The units should be stored in a temperature controlled area, a roofed over walled enclosure that provides protection from the elements (rain, snow, wind-blown dust, etc.), and whose temperature can be maintained between +40 deg. F and +120 deg. F. If extended high humidity is expected to be a problem, all exposed parts should be inspected before storage and all surfaces that have the paint scratched, damaged, or worn should be recoated with a air dry enamel paint. All surfaces should then be sprayed with a rust-inhibiting oil.

Pump should be stored in its original shipping container. On initial start up, rotate impeller by hand to assure seal and impeller rotate freely. If it is required that the pump be installed and tested before the long term storage begins, such installation will be allowed provided:

- 1.) The pump is not installed under water for more than one (1) month.
- 2.) Immediately upon satisfactory completion of the test, the pump is removed, thoroughly dried, repacked in the original shipping container, and placed in a temperature controlled storage area.

### SERVICE CENTERS:

For the location of the nearest Barnes Service Center, check your Barnes representative or Crane Pumps & Systems, Inc., Service Department in Piqua, Ohio, telephone (937) 778-8947 or in Brampton, Ontario, Canada (905) 457-6223.

### INSTALLATION:

**Location** - The pump is designed to fit into your basin resting on the supplied stand.

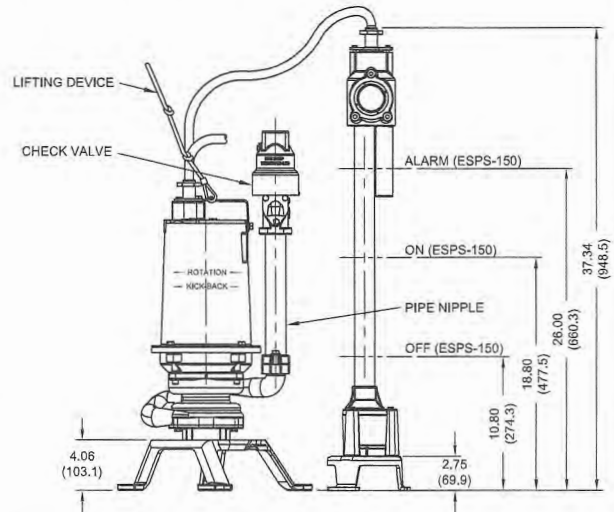

FIGURE 1



**ELECTRICAL CONNECTIONS:**

**Pump Cables** - The cord assembly mounted to the pump must **NOT** be modified in any way except for shortening to a specific application. Any splice between the pump and the control panel must be made in accordance with the National Electric Code or the Canadian Electric Code and all applicable state, province and local electric codes. It is recommended that a junction box, be mounted outside the sump or be of at least Nema 4 (EEMAC-4) construction if located within the wet well. **DO NOT USE THE POWER OR CONTROL CABLES TO LIFT PUMP!**

**Overload Protection** - The type of in-winding overload protector used is referred to as an inherent overheating protector and operates on the combined effect of temperature and current. This means that the overload protector will trip out and shut the pump off if the windings become too hot, or the load current becomes too high. It will then automatically reset and start the pump after the motor cools to a safe temperature. In the event of an overload, the source of this condition should be determined and rectified immediately. **DO NOT LET THE PUMP CYCLE OR RUN IF AN OVERLOAD CONDITION OCCURS !**

**Wire Size** - If additional cable is required consult a qualified electrician for proper wire size.

**Pump Internal Wiring**

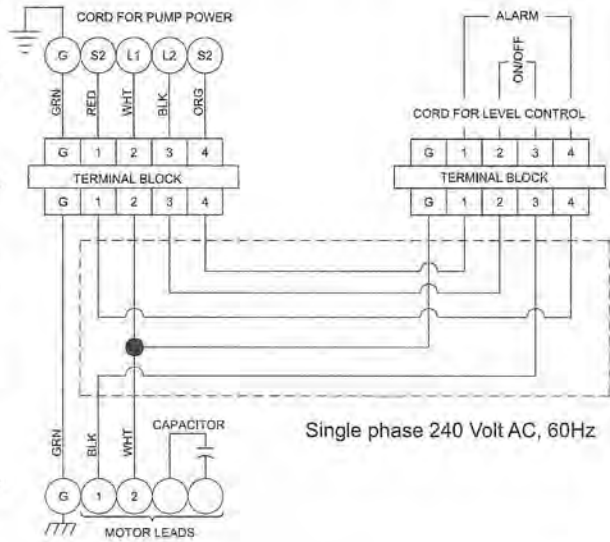

**FIGURE 2**

## Remove Parts Box from Basin, Attach Rope to Pumps, Record Pump Data

### STEPS & TIPS:

Remove Parts Box. It should contain the following items: Lifting device, Discharge Piping, Stand, Level Control Mounting & Cord, Check Valve, Misc. Hardware

- Record pump information on user guide for future reference.
- Attach lifting device to pump.
  1. Make a small overhand loop in the rope.
  2. Bring the short end through the overhand loop.
  3. Place short end behind the fixed part of the rope.
  4. Bring end around and back into the loop.
  5. Pull on the fixed end of the rope away from the loop to tighten the knot.

### • NEVER LOWER OR RAISE PUMP BY THE CORD!

- Secure pump base and level control with hardware provided.
- Assemble pipe and check valve to pump.

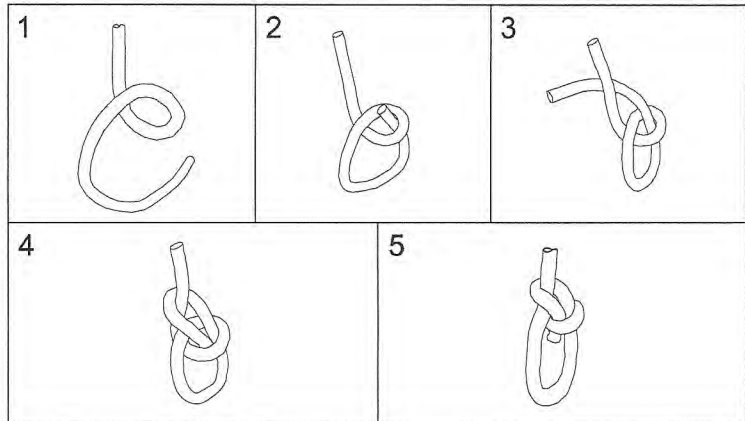

	HP.	Volts	Code	Ph.	Hz.
<b>BARNES</b> 1055005	RPM	FLA	Model No.	SGV2022L	
	Part No.	105234	Serial No.	C690039-0100	
	Impeller Dia.		Max. Liq. Temp.	°C	Ins. Class
WARNING TO REDUCE RISK OF ELECTRICAL SHOCK DISCONNECT THE PUMP FROM THE POWER SOURCE BEFORE HANDLING OR SERVICING. SEE INSTRUCTION MANUAL FOR PROPER INSTALLATION. SEE WARNING PLATE FOR ADDITIONAL CAUTIONS.					
		<b>UL LISTED</b>		CSA 108 UL 778 LR 16567 NRTL/C SUBMERSIBLE SEWAGE PUMP 62H3	
BARNES PUMPS, INC. Mansfield, Ohio					

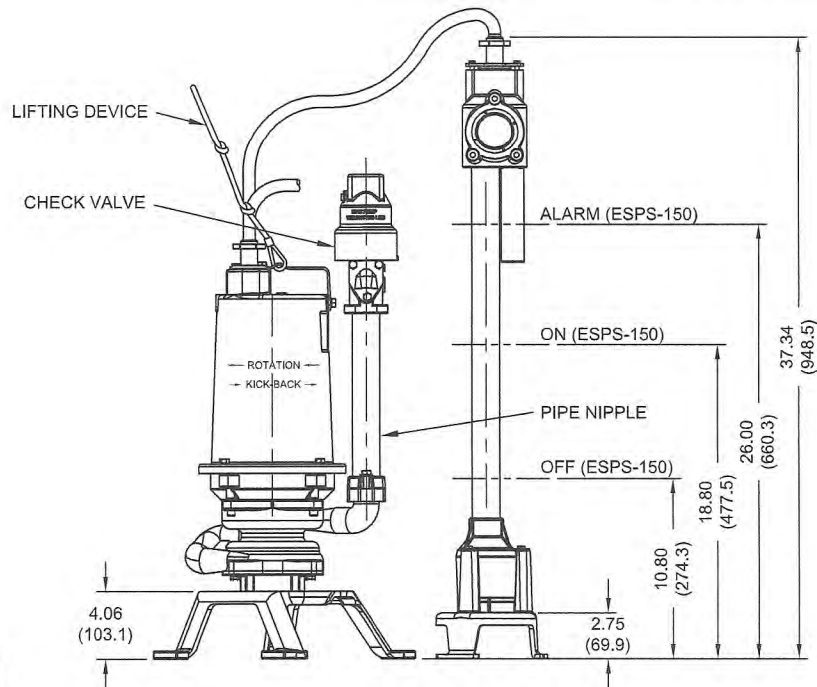

**FIGURE 3**

## Pump & Level Control Wiring

**Power/Control Cable-** Insert female end of cable plug into housing bore aligning alignment mark with hole in terminal block see Figures 4 & 5. Tighten bolts on compression flange until flush with motor housing.

Pump Power - Large Pin  
Level Control - Small Pin

Level control cord has molded fitting at both ends of the cord. Install one end to the Pump and the other end to the Level Control.

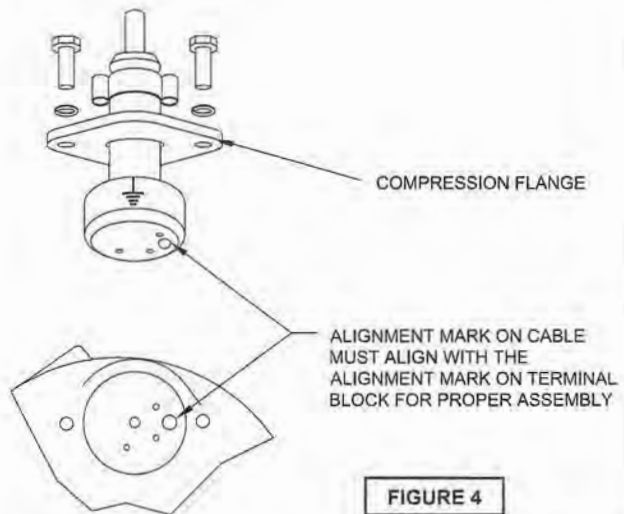

FIGURE 4

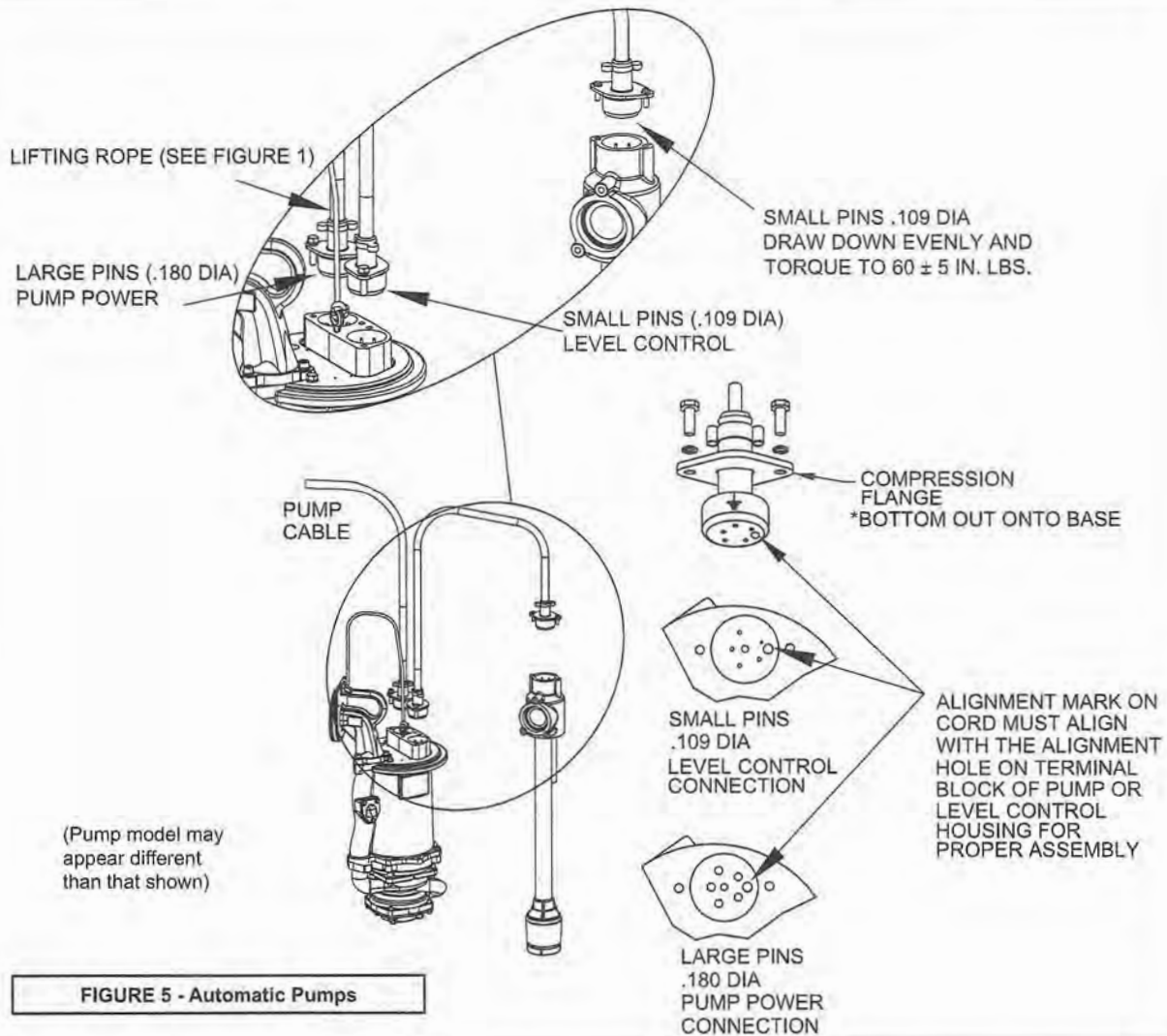

FIGURE 5 - Automatic Pumps



## Setting Pump Into Basin

### STEPS & TIPS:

- Once the lifting device is attached to the pump, secure it so it will not fall into basin.
- Thread flex hose assembly (provided by others or reuse) into check valve on pump.
- Install Hose Discharge connection to other end of hose assembly.
- Secure pump cord(s) and hose assembly so they will not fall into basin and lower pump into basin.
- Follow all O.S.H.A. guidelines.
- **NEVER LOWER OR RAISE PUMP BY THE CORD!**

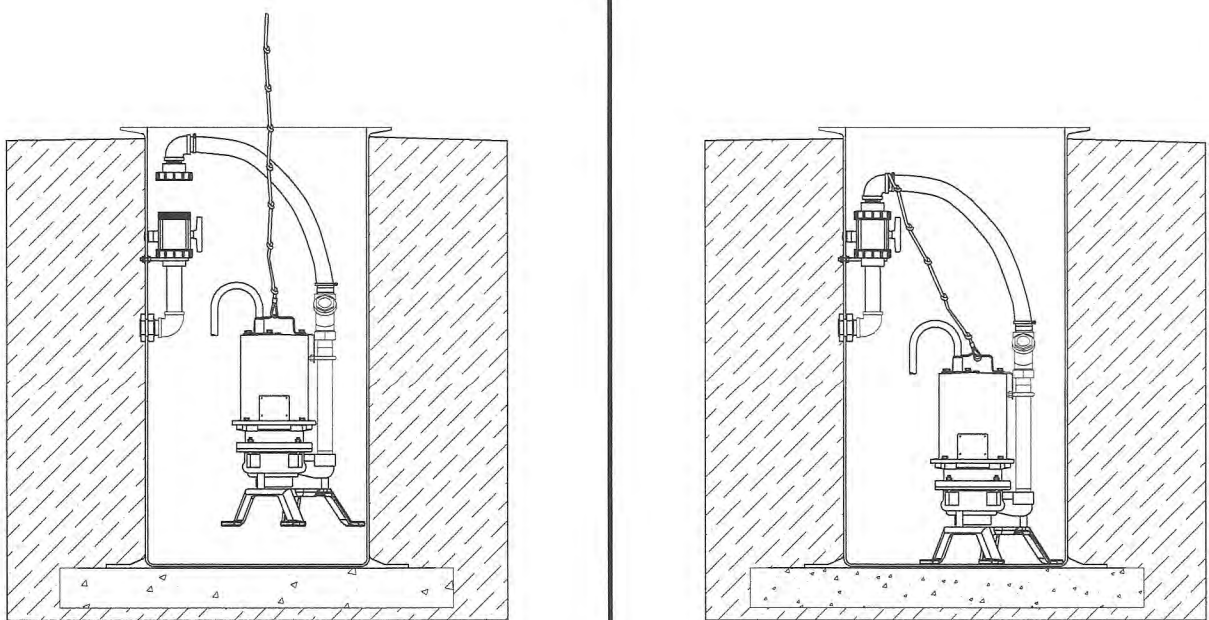

Typical Installation Shown -  
Installations will vary

FIGURE 5

# Typical Wiring Diagram (Generic)

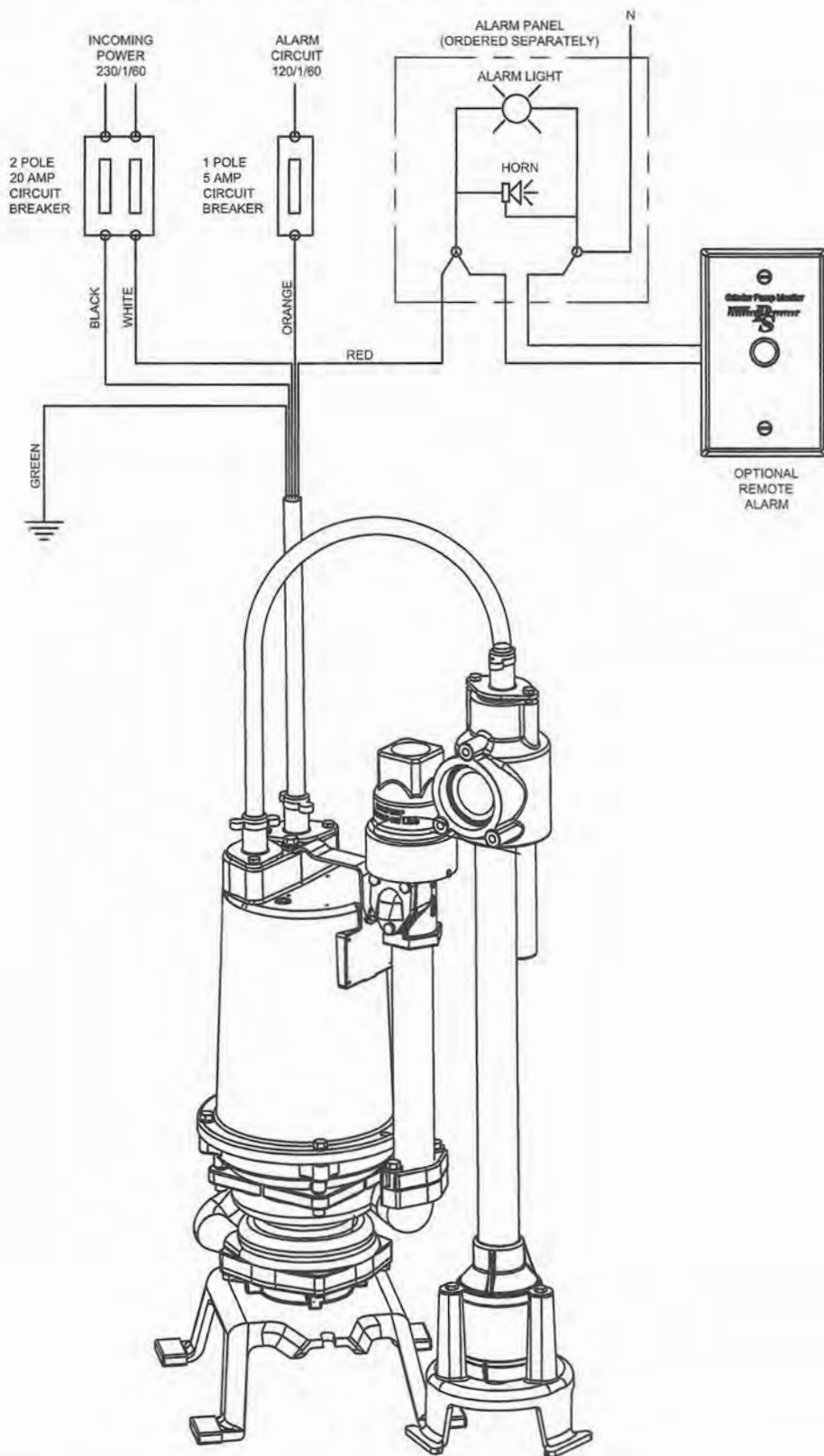

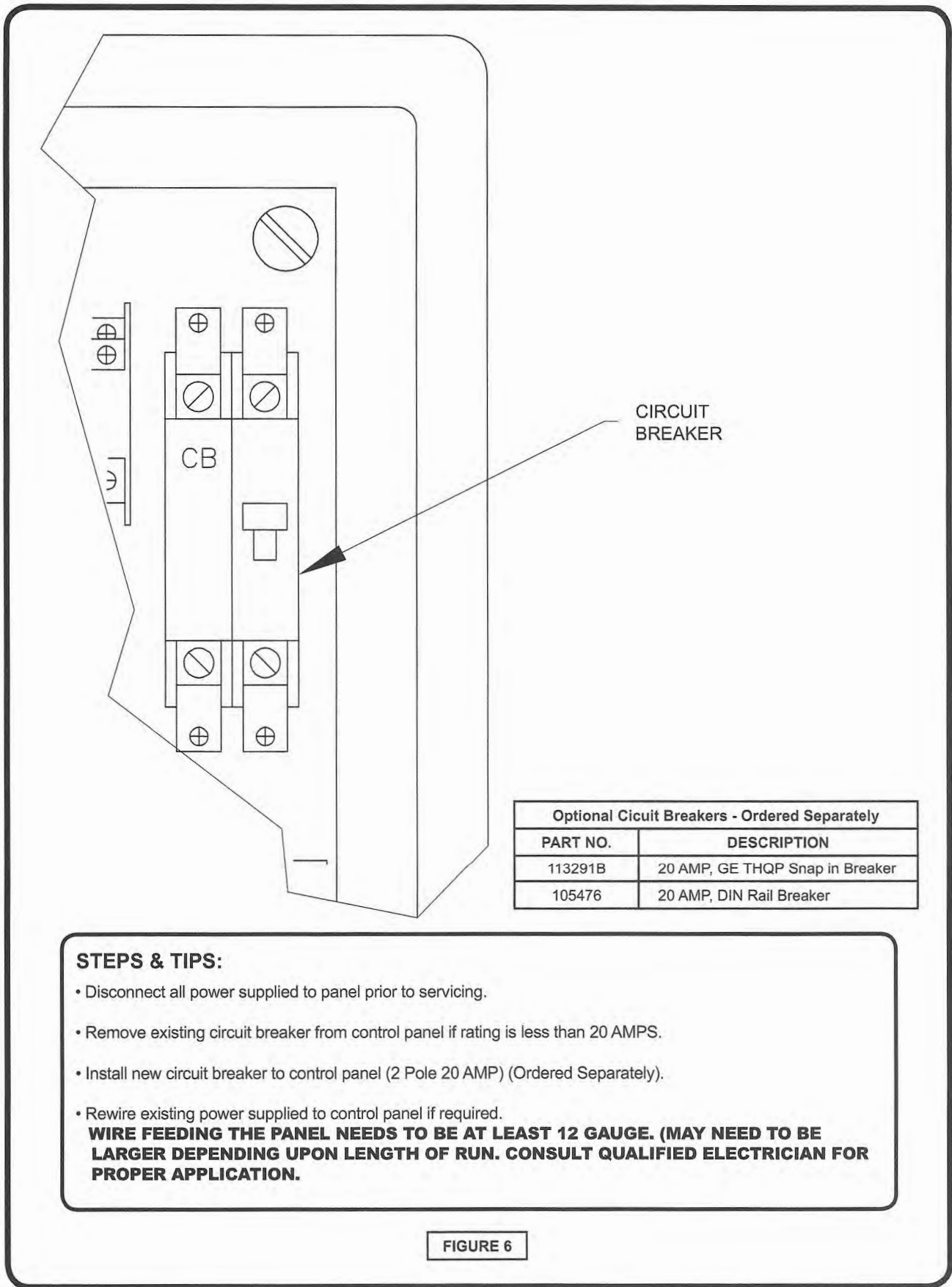

CIRCUIT  
BREAKER

Optional Circuit Breakers - Ordered Separately	
PART NO.	DESCRIPTION
113291B	20 AMP, GE THQP Snap in Breaker
105476	20 AMP, DIN Rail Breaker

**STEPS & TIPS:**

- Disconnect all power supplied to panel prior to servicing.
- Remove existing circuit breaker from control panel if rating is less than 20 AMPS.
- Install new circuit breaker to control panel (2 Pole 20 AMP) (Ordered Separately).
- Rewire existing power supplied to control panel if required.

**WIRE FEEDING THE PANEL NEEDS TO BE AT LEAST 12 GAUGE. (MAY NEED TO BE LARGER DEPENDING UPON LENGTH OF RUN. CONSULT QUALIFIED ELECTRICIAN FOR PROPER APPLICATION.)**

FIGURE 6



## EONE 200 SERIES PACKAGE WIRING

INCOMING 12 GA. CABLE	PUMP CABLE
WHITE	WHITE
BLACK	BLACK
* BARE	GREEN
INCOMING 14 GA. CABLE	
BLACK	ORANGE
WHITE	RED
* BARE	GREEN

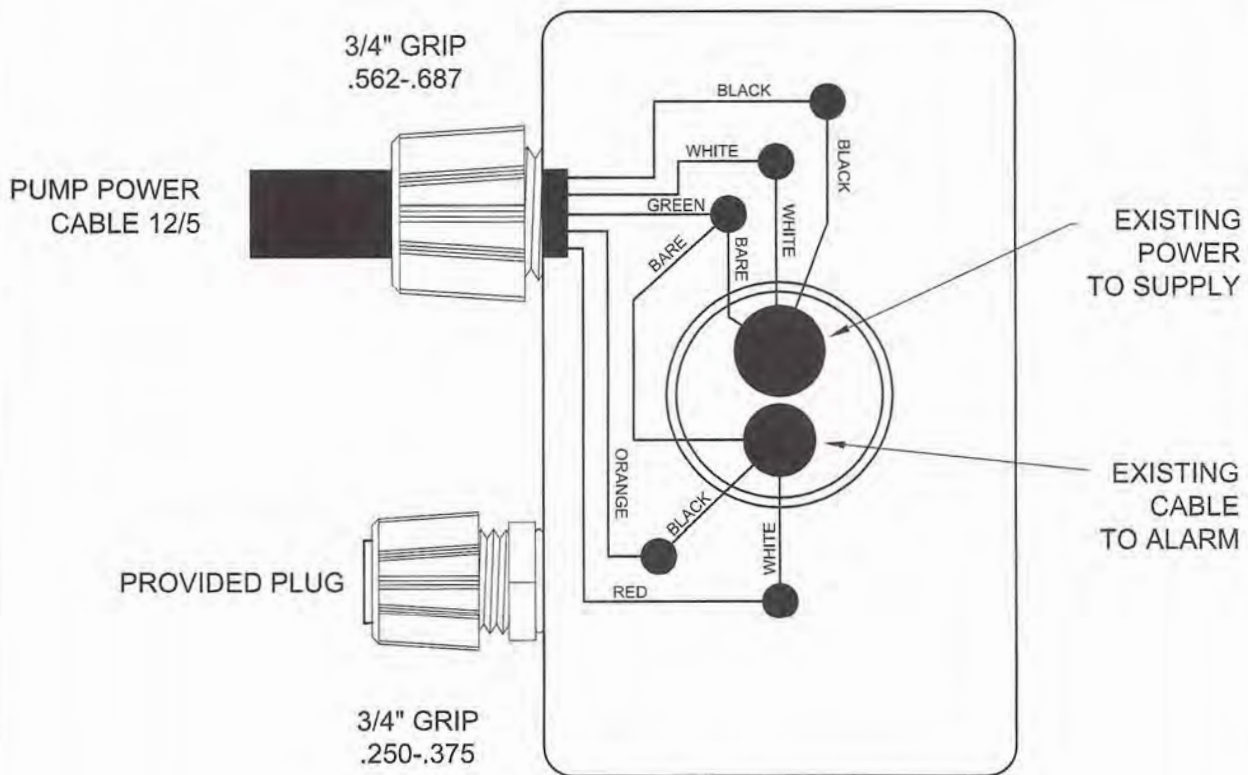

NOTE: DETERMINE IF THE PACKAGE CONTAINS AN EQD  
(QUICK DISCONNECT) IF SO GO TO PAGES 14, FIGURE 8.

\*TIE BOTH BARE GROUND WIRES W/ GREEN PUMP GROUND.

FIGURE 7

## 2000 SERIES STATION WIRING

### WIRING FOR UNITS NOT SUPPLIED WITH FACTORY WIRED EQD

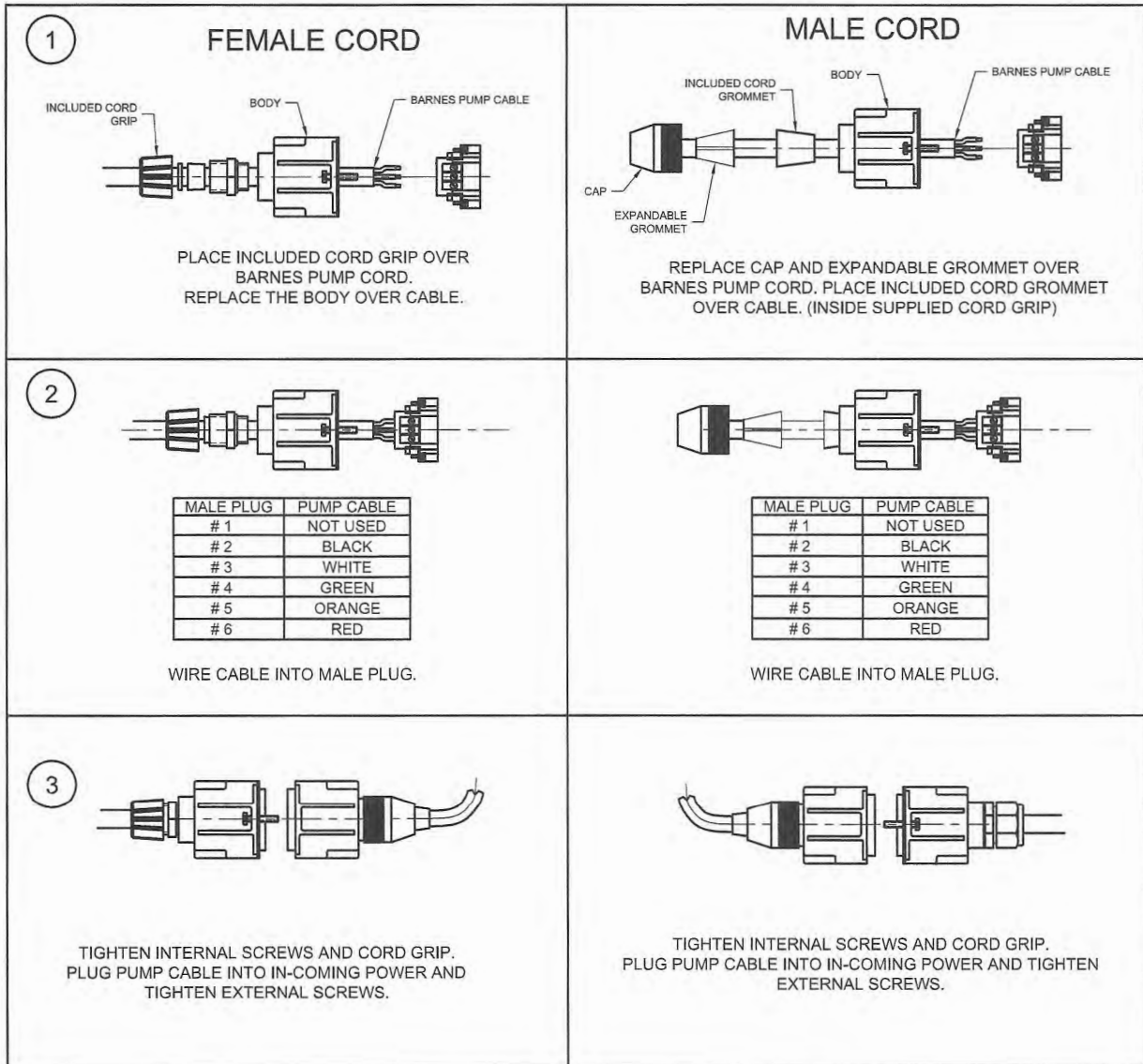

**FIGURE 8**

# PARTS LIST - OGP2022AUE

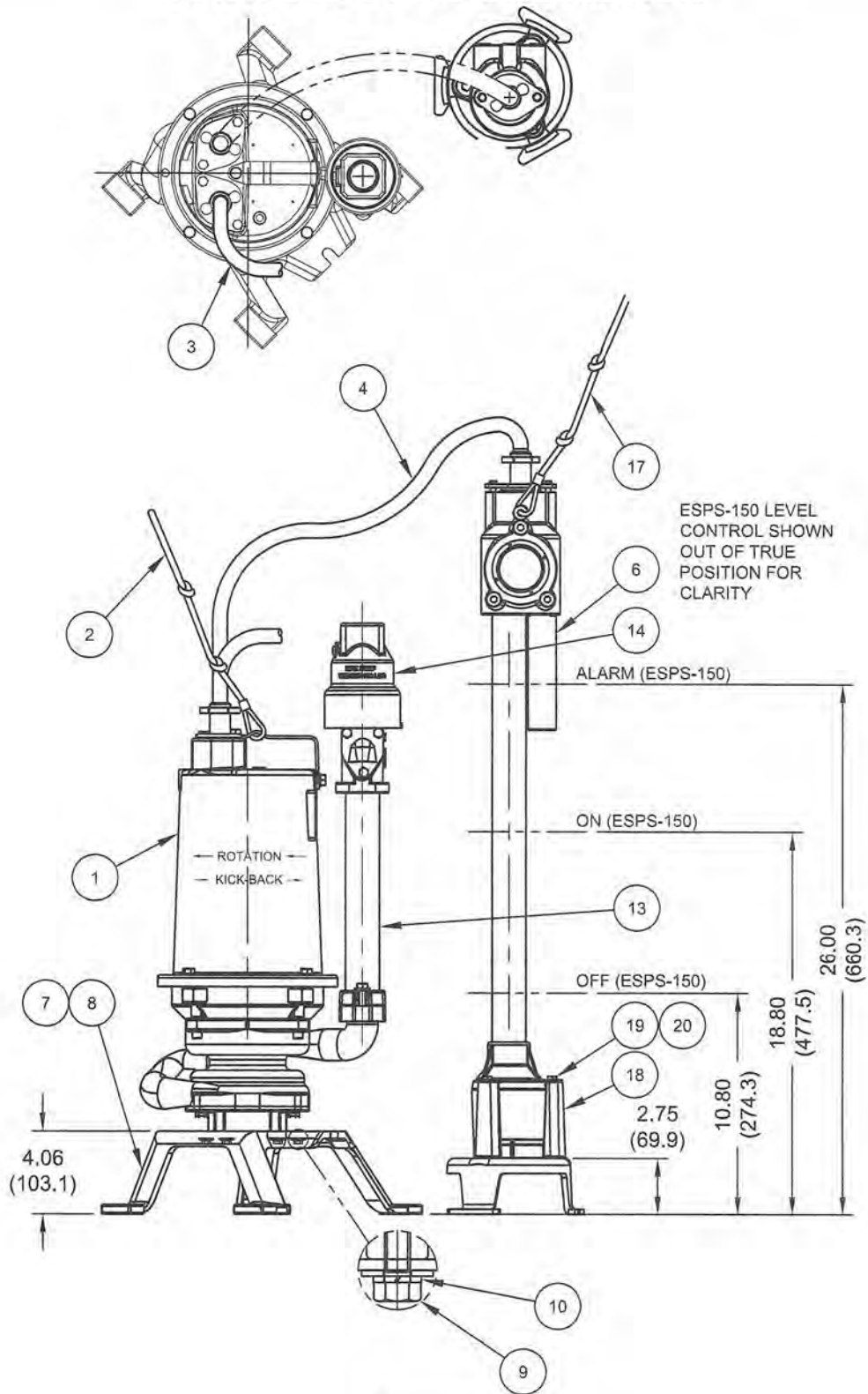

FIGURE 9



## PARTS LIST - OGP2022AUE

ITEM No.	QTY.	PART No.	DESCRIPTION
1	1	115329 NCM	OGP2022AUE Pump
2	1	093973	Lifting Rope, Poly
3	1	See Chart	Cord, Pump Power
4	1	See Chart	Cord, Level Control
5	1	See Chart	Hose Assy. (Not Shown) (Ordered Separately)
6	1	121676NC	Assy., ESPS-150, No Cord, No Mount
7	1	130978	Base, Pump, 1 & 2 HP Grinder
8	4	131023	Cap, Vinyl, Foot
9	4	1-6-1	¼-20, .875", HXHD Bolt, SS
10	4	20-5-1	Washer, Flat, ¼", 300 SS
* 11	1	111912	Grip, Cord, .75", .250-.375" (Not Shown)

ITEM No.	QTY.	PART No.	DESCRIPTION
* 12	5	055844	Connector, Wire, Screw-on (Not Shown)
13	1	102174	Nipple, Pipe, 1¼", 11", 304SS
14	1	121583A	Valve Assy, PRS, 1¼" NPT
* 15	2	069054V	Grip, Cord, ¾", .625-.750 (Not Shown)
* 16	2	097310	Nut, Conduit, ¾" NPT, AL (Not Shown)
17	1	115664	Rope, Poly, ESPS
18	1	130979	Base, ESPS, CI
19	3	1-4-1	¼-20, .625", HXHD Bolt, SS
20	3	131836	Washer, 1.00 O.D. x .34 I.D. x .05, 18-8 SS

\* Used for E-One 200 Series Stations

Item 3 - 12/5 Pump Power Cords	
Part No.	Description
113274	15' - 12/5 SOW, No EQD
113274XC	30' - 12/5 SOW, No EQD
131960	15' - 12/5 SOW with EQD
131960XC	30' - 12/5 SOW with EQD

Item 4 - 14/5 SOW Level Control Cords	
Part No.	Description
113315A	8' - 14/5 SOW Cord
113315	15' - 14/5 SOW Cord
113315XC	30' - 14/5 SOW Cord

Item 5 - 1.25" NPT Flex Hose			
Part No	Description	Overall Length	Basin Depth
130797	Hose Assembly, SS Ends	46"	48" & 60"
130797A	Hose Assembly, SS Ends	58"	72"
130797B	Hose Assembly, SS Ends	70"	84"

# PARTS LIST - OGT1022AUE

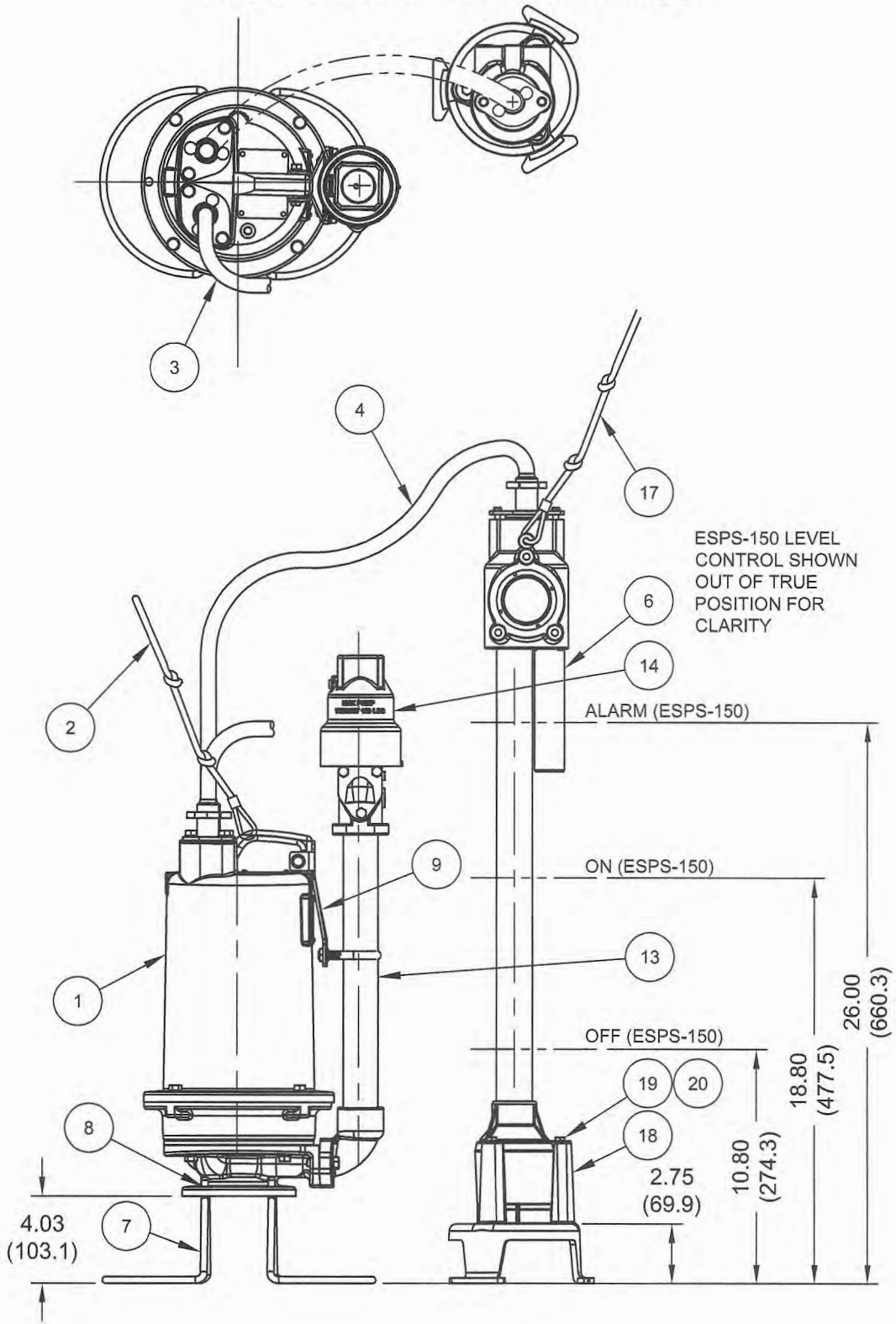

FIGURE 10

## PARTS LIST - OGT1022AUE

ITEM No.	QTY.	PART No.	DESCRIPTION
1	1	141194 NCM	OGT1022AUE Pump
2	1	093973	Lifting Rope, Poly
3	1	See Chart	Cord, Pump Power
4	1	See Chart	Cord, Level Control
5	1	See Chart	Hose Assy. (Not Shown) (Ordered Separately)
6	1	121676NC	Assy., ESPS-150, No Cord, No Mount
7	2	137083	Base, Pump
8	4	140707	Retaining Clip
9	1	116607-KIT	Bracket, Moveable, Upper
* 11	1	111912	Grip, Cord, .75", .250-.375" (Not Shown)

ITEM No.	QTY.	PART No.	DESCRIPTION
* 12	5	055844	Connector, Wire, Screw-on (Not Shown)
13	1	102174	Nipple, Pipe, 1¼", 11", 304SS
14	1	121583A	Valve Assy, PRS, 1¼" NPT
* 15	2	069054V	Grip, Cord, ¾", .625-.750 (Not Shown)
* 16	2	097310	Nut, Conduit, ¾" NPT, AL (Not Shown)
17	1	115664	Rope, Poly, ESPS
18	1	130979	Base, ESPS, CI
19	3	1-4-1	¼"-20, .625", HXHD Bolt, SS
20	3	131836	Washer, 1.00 O.D. x .34 I.D. x .05, 18-8 SS

\* Used for E-One 200 Series Stations

### Item 3 - 12/5 Pump Power Cords

Part No.	Description
113274	15' - 12/5 SOW, No EQD
113274XC	30' - 12/5 SOW, No EQD
131960	15' - 12/5 SOW with EQD
131960XC	30' - 12/5 SOW with EQD

### Item 4 - 14/5 SOW Level Control Cords

Part No.	Description
113315A	8' - 14/5 SOW Cord
113315	15' - 14/5 SOW Cord
113315XC	30' - 14/5 SOW Cord

### Item 5 - 1.25" NPT Flex Hose

Part No	Description	Overall Length	Basin Depth
130797	Hose Assembly, SS Ends	46"	48" & 60"
130797A	Hose Assembly, SS Ends	58"	72"
130797B	Hose Assembly, SS Ends	70"	84"





**BARNES®****burks®****WEINMAN®****DEMING®****PROSSER®**

## Limited 24 Month Warranty

Crane Pumps & Systems warrants that products of our manufacture will be free of defects in material and workmanship under normal use and service for twenty-four (24) months after manufacture date, when installed and maintained in accordance with our instructions. This warranty gives you specific legal rights, and there may also be other rights which vary from state to state. In the event the product is covered by the Federal Consumer Product Warranties Law (1) the duration of any implied warranties associated with the product by virtue of said law is limited to the same duration as stated herein, (2) this warranty is a LIMITED WARRANTY, and (3) no claims of any nature whatsoever shall be made against us, until the ultimate consumer, his successor, or assigns, notifies us in writing of the defect, and delivers the product and/or defective part(s) freight prepaid to our factory or nearest authorized service station. Some states do not allow limitations on how long an implied warranty lasts, so the above limitation may not apply. **THE SOLE AND EXCLUSIVE REMEDY FOR BREACH OF ANY AND ALL WARRANTIES WITH RESPECT TO ANY PRODUCT SHALL BE TO REPLACE OR REPAIR AT OUR ELECTION, F.O.B. POINT OF MANUFACTURE OR AUTHORIZED REPAIR STATION, SUCH PRODUCTS AND/OR PARTS AS PROVEN DEFECTIVE. THERE SHALL BE NO FURTHER LIABILITY, WHETHER BASED ON WARRANTY, NEGLIGENCE OR OTHERWISE.** Unless expressly stated otherwise, guarantees in the nature of performance specifications furnished in addition to the foregoing material and workmanship warranties on a product manufactured by us, if any, are subject to laboratory tests corrected for field performance. Any additional guarantees, in the nature of performance specifications must be in writing and such writing must be signed by our authorized representative. Due to inaccuracies in field testing if a conflict arises between the results of field testing conducted by or for user, and laboratory tests corrected for field performance, the latter shall control. **RECOMMENDATIONS FOR SPECIAL APPLICATIONS OR THOSE RESULTING FROM SYSTEMS ANALYSES AND EVALUATIONS WE CONDUCT WILL BE BASED ON OUR BEST AVAILABLE EXPERIENCE AND PUBLISHED INDUSTRY INFORMATION. SUCH RECOMMENDATIONS DO NOT CONSTITUTE A WARRANTY OF SATISFACTORY PERFORMANCE AND NO SUCH WARRANTY IS GIVEN.**

This warranty shall not apply when damage is caused by (a) improper installation, (b) improper voltage (c) lightning (d) excessive sand or other abrasive material (e) scale or corrosion build-up due to excessive chemical content. Any modification of the original equipment will also void the warranty. We will not be responsible for loss, damage or labor cost due to interruption of service caused by defective parts. Neither will we accept charges incurred by others without our prior written approval.

This warranty is void if our inspection reveals the product was used in a manner inconsistent with normal industry practice and/or our specific recommendations. The purchaser is responsible for communication of all necessary information regarding the application and use of the product. **UNDER NO CIRCUMSTANCES WILL WE BE RESPONSIBLE FOR ANY OTHER DIRECT OR CONSEQUENTIAL DAMAGES, INCLUDING BUT NOT LIMITED TO TRAVEL EXPENSES, RENTED EQUIPMENT, OUTSIDE CONTRACTOR FEES, UNAUTHORIZED REPAIR SHOP EXPENSES, LOST PROFITS, LOST INCOME, LABOR CHARGES, DELAYS IN PRODUCTION, IDLE PRODUCTION, WHICH DAMAGES ARE CAUSED BY ANY DEFECTS IN MATERIAL AND/OR WORKMANSHIP AND/OR DAMAGE OR DELAYS IN SHIPMENT. THIS WARRANTY IS EXPRESSLY IN LIEU OF ANY OTHER EXPRESS OR IMPLIED WARRANTY, INCLUDING ANY WARRANTY OF MERCHANTABILITY OR FITNESS FOR A PARTICULAR PURPOSE.**

No rights extended under this warranty shall be assigned to any other person, whether by operation of law or otherwise, without our prior written approval.



A Crane Co. Company

### PUMPS & SYSTEMS

420 Third Street  
Piqua, Ohio 45356  
(937) 778-8947  
Fax (937) 773-7157  
[www.cranepumps.com](http://www.cranepumps.com)

83 West Drive  
Brampton, Ont. Canada L6T 2J6  
(905) 457-6223  
Fax (905) 457-2650

**IMPORTANT!**  
**WARRANTY REGISTRATION**

Your product is covered by the enclosed Warranty.  
To complete the Warranty Registration Form go to:

<http://www.cranepumps.com/ProductRegistration/>

If you have a claim under the provision of the warranty, contact your local  
Crane Pumps & Systems, Inc. Distributor.

**RETURNED GOODS**

**RETURN OF MERCHANDISE REQUIRES A "RETURNED GOODS AUTHORIZATION".  
CONTACT YOUR LOCAL CRANE PUMPS & SYSTEMS, INC. DISTRIBUTOR.**



**Products Returned Must Be Cleaned, Sanitized,  
Or Decontaminated As Necessary Prior To Shipment,  
To Insure That Employees Will Not Be Exposed To Health  
Hazards In Handling Said Material. All Applicable Laws  
And Regulations Shall Apply.**



A Crane Co. Company

# PUMPS & SYSTEMS

## START-UP REPORT

### General Information

Pump Owner's Name: \_\_\_\_\_  
 Address: \_\_\_\_\_  
 Location of Installation: \_\_\_\_\_  
 Contact Person: \_\_\_\_\_ Phone: \_\_\_\_\_  
 Purchased From: \_\_\_\_\_

### Nameplate Data

Pump Model #: \_\_\_\_\_ Serial #: \_\_\_\_\_  
 Part #: \_\_\_\_\_ Impeller Diameter: \_\_\_\_\_  
 Voltage: \_\_\_\_\_ Phase: \_\_\_\_\_  $\emptyset$  Hertz: \_\_\_\_\_ Horsepower: \_\_\_\_\_  
 Full Load Amps: \_\_\_\_\_ Service Factor Amps: \_\_\_\_\_  
 Motor Manufacturer: \_\_\_\_\_

### Controls

Control panel manufacturer: \_\_\_\_\_  
 Model/Part number: \_\_\_\_\_  
 Number of pumps operated by control panel: \_\_\_\_\_  
 Short circuit protection? YES\_\_\_ NO\_\_\_ Type: \_\_\_\_\_  
 Number and size of short circuit device(s): \_\_\_\_\_ Amp rating: \_\_\_\_\_  
 Overload Type: \_\_\_\_\_ Size: \_\_\_\_\_ Amp rating: \_\_\_\_\_  
 Do protection devices comply with pump and motor Amp rating? YES\_\_\_ NO\_\_\_  
 Are all electrical and panel entry connections tight? YES\_\_\_ NO\_\_\_  
 Is the interior of the panel dry? YES\_\_\_ NO\_\_\_  
 Liquid level Control Brand and Model: \_\_\_\_\_

### Pre-Startup

#### All Pumps

Type of equipment: NEW\_\_\_ REBUILT\_\_\_ USED\_\_\_  
 Condition of equipment at Start-Up: DRY\_\_\_ WET\_\_\_ MUDDY\_\_\_  
 Was Equipment Stored? YES\_\_\_ NO\_\_\_ Length of Storage: \_\_\_\_\_  
 Liquid being pumped: \_\_\_\_\_ Liquid Temperature: \_\_\_\_\_  
 Supply Voltage/Phase/Frequency matches nameplate? YES\_\_\_ NO\_\_\_  
 Shaft turns freely? YES\_\_\_ NO\_\_\_  
 Direction of rotation verified for 3 $\emptyset$  motors? YES\_\_\_ NO\_\_\_  
 Debris in piping or wet well? YES\_\_\_ NO\_\_\_  
 Debris removed in your presence? YES\_\_\_ NO\_\_\_  
 Pump case/wet well filled with liquid before startup? YES\_\_\_ NO\_\_\_  
 Is piping properly supported? YES\_\_\_ NO\_\_\_

#### Non-Submersible Pumps

Is base plate properly installed / grouted? YES\_\_\_ NO\_\_\_ N/A\_\_\_  
 Coupling Alignment Verified per I&O Manual? YES\_\_\_ NO\_\_\_ N/A\_\_\_  
 Grease Cup/Oil Reservoir Level checked? YES\_\_\_ NO\_\_\_ N/A\_\_\_



**Submersible Pumps**

Resistance of cable and pump motor (measured at pump control):

Red-Black: \_\_\_\_\_ Ohms(Ω) Red-White: \_\_\_\_\_ Ohms(Ω) White-Black: \_\_\_\_\_ Ohms(Ω)

Resistance of Ground Circuit between Control Panel and outside of pump: \_\_\_\_\_ Ohms(Ω)

MEG Ohms check of insulation:

Red to Ground: \_\_\_\_\_ White to Ground: \_\_\_\_\_ Black to Ground: \_\_\_\_\_

**Operational Checks**

Is there noise or vibration present? YES \_\_\_ NO \_\_\_ Source of noise/vibration: \_\_\_\_\_

Does check valve operate properly? YES \_\_\_ NO \_\_\_ N/A \_\_\_

Is system free of leaks? YES \_\_\_ NO \_\_\_ Leaks at: \_\_\_\_\_

Does system appear to operate at design flow rate? YES \_\_\_ NO \_\_\_

Nominal Voltage: \_\_\_\_\_ Phase: 1Ø 3Ø (select one)

Voltage Reading at panel connection, Pump OFF: L1, L2 \_\_\_\_\_ L2, L3 \_\_\_\_\_ L1, L3 \_\_\_\_\_

Voltage Reading at panel connection, Pump ON: L1, L2 \_\_\_\_\_ L2, L3 \_\_\_\_\_ L1, L3 \_\_\_\_\_

Amperage Draw, Pump ON: L1 \_\_\_\_\_ L2 \_\_\_\_\_ L3 \_\_\_\_\_

**Submersible Pumps**

Are BAF and guide rails level / plumb? YES \_\_\_ NO \_\_\_

Is pump seated on discharge properly? YES \_\_\_ NO \_\_\_

Are level controls installed away from turbulence? YES \_\_\_ NO \_\_\_

Is level control operating properly? YES \_\_\_ NO \_\_\_

Is pump fully submerged during operation? YES \_\_\_ NO \_\_\_

**Follow up/Corrective Action Required**

YES \_\_\_ NO \_\_\_

**Additional Comments:**

\_\_\_\_\_  
\_\_\_\_\_  
\_\_\_\_\_  
\_\_\_\_\_  
\_\_\_\_\_  
\_\_\_\_\_

Startup performed by: \_\_\_\_\_ Date: \_\_\_\_\_

**Present at Start-Up**

( ) Engineer: \_\_\_\_\_ ( ) Operator: \_\_\_\_\_

( ) Contactor: \_\_\_\_\_ ( ) Other: \_\_\_\_\_

**All parties should retain a copy of this report for future trouble shooting/reference**



**PUMPS & SYSTEMS**

A Crane Co. Company

420 Third Street  
Piqua, Ohio 45356  
(937) 778-8947  
Fax (937) 773-7157  
www.cranepumps.com

83 West Drive  
Brampton, Ont. Canada L6T 2J6  
(905) 457-6223  
Fax (905) 457-2650