

MEMO

TO: Chris Music
Steve Beatty

FR: Scott Spidel

DA: 03-06-2019

RE: BC-58 Williams TAR 27
Encroachment Permit No. 1490

Robert Watkins, Bullitt County Road Director agrees with the temporary entrance off of Rams Run Road for proposed pipeline construction. Culvert required 15" diameter by 30 ft. following construction profile as shown on the drawing attached.

Thanks,

Scott

**BULLITT COUNTY ENCROACHMENT PERMIT
FOR TILE PLACEMENT ON COUNTY MAINTAINED ROADS**

Issued by
**BULLITT COUNTY ROAD DEPARTMENT
1679 SOUTH PRESTON HWY.
P.O. BOX 768
SHEPHERDSVILLE, KY 40165
PHONE: 502-543-2510 FAX PHONE: 502-543-6889**

Date: 02/19/2019

Permit No. 1490

Applicants Name: LOUISVILLE GAS AND ELECTRIC COMPANY

Applicants Address: 6900 Enterprise Drive, Louisville, KY 40214

Applicants Phone Number: [REDACTED] **Cell#:** _____

Location of Installation: Temporary Entrance at Ram's Run Rd. (CR-1147) Mile Post: 0.94 LONG: -85.66248255 LAT: 37.95268472

Signature of Applicant: 

*By signing above, I hereby certify and affirm that I am the wonder or legal occupant of the above-referenced property pursuant to Ordinance No.86-24 VIA EASEMENT RIGHTS
NOTIFICATION DATE FOR SIZES WAS 5 MAR. 19*

Size of tile to be installed with approval of the Bullitt County Road Department.

Diameter: 15" **LENGTH** 30'

No tile to be installed less than fifteen (15) inches in diameter and twenty (20) feet in length unless approval is given by the Road Dept. No plastic PVC tiles are to be installed, only galvanized, concrete, or steel will be approved.

ON SITE _____

Date Tile Installed: _____

INSTALLED BY _____

METAL OR CONCRETE _____
COUNTY ROAD SUPERINTENDENT 

LG&E Bullitt County Pipeline Project
Access Road



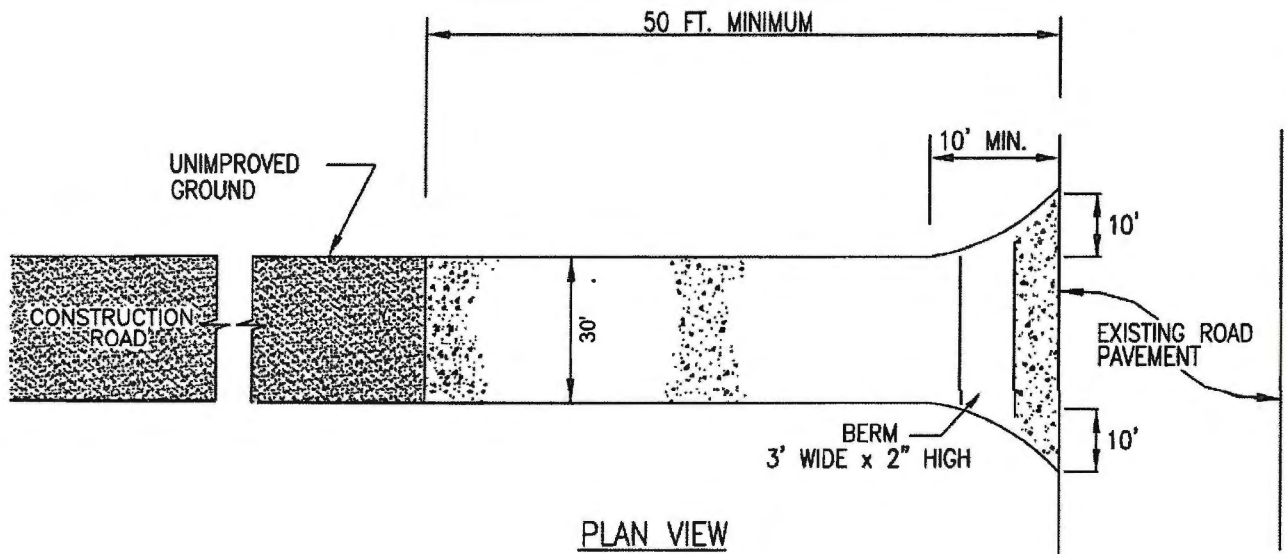

PLAN VIEW

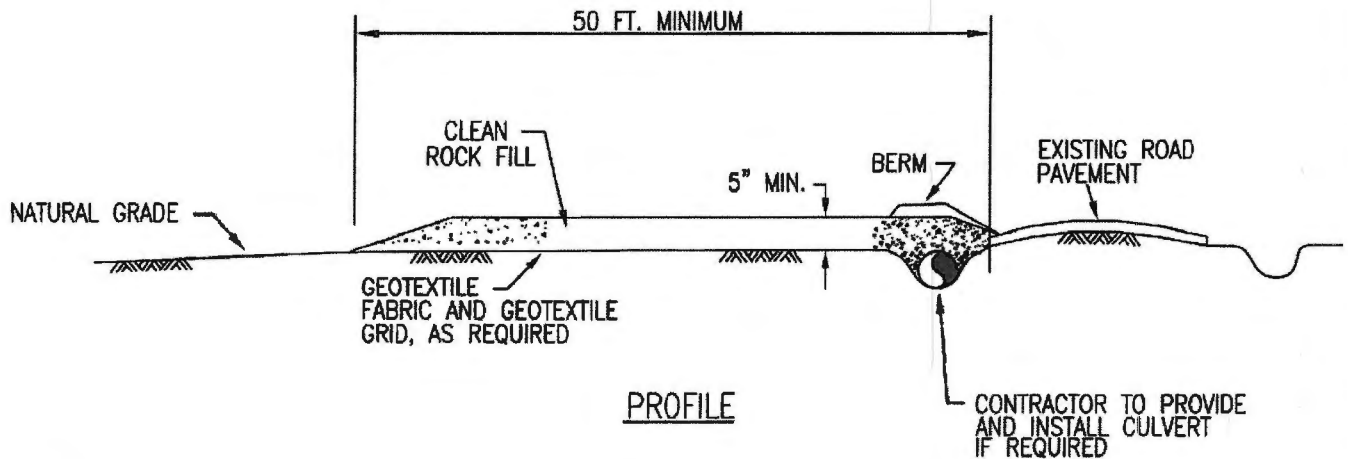

PROFILE

NOTES:

1. ACCESS PADS, AS ILLUSTRATED ABOVE, ARE TO BE INSTALLED ADJACENT TO EXISTING PAVED ROADS AT LOCATIONS IDENTIFIED ON THE CONSTRUCTION DRAWINGS OR AS DIRECTED BY THE COMPANY'S INSPECTOR.
2. IF USED IN AGRICULTURAL LAND, ROCK SHALL BE PLACED ON A GEOTEXTILE FABRIC TO FACILITATE ROCK REMOVAL.
3. SHOULD THE ROCK PAD BECOME INEFFECTIVE FOR REDUCING THE BUILDUP OF MUD AND DIRT AND MINIMIZING TRACKING ONTO THE PAVED ROAD, THE CONTRACTOR SHALL WASH THE EXISTING ROCK FILL SURFACE OR ADD A ROCK FILL LAYER TO THE ACCESS PAD.
4. CONTRACTOR SHALL KEEP PAVED ROAD SURFACES CLEAR OF MUD AND DEBRIS.
5. PRIOR TO PERMANENT SEEDING, CONTRACTOR SHALL REMOVE ALL IMPORTED ROCK FILL MATERIAL, GEOTEXTILE FABRIC AND CULVERT (IF INSTALLED) AND RESTORE THE GROUND TO NATURAL CONTOURS UNLESS OTHERWISE DIRECTED BY COMPANY'S INSPECTOR.

ENEngineering

28100 TORCH PARKWAY
WARRENVILLE, IL. 60555
TEL. 630-353-4000
FAX 630-353-7777
WWW.ENENGINEERING.COM

DRAWN BY	BK (ENE)
CHECKED BY	MDW (ENE)
PROJECT ENG.	MDW (ENE)
APPROVED BY	DAD (ENE)
DATE	09-08-16
SCALE	N.T.S.

**TYPICAL STABILIZED
CONSTRUCTION ENTRANCE**



DRAWING:

EXHIBIT-04

MEMO

TO: Chris Music
Steve Beatty

FR: Scott Spidel

DA: 03-06-2019

RE: BC-17 Raymond TAR 11
Encroachment Permit No. 1491

Robert Watkins, Bullitt County Road Director agrees with the temporary entrance off of Cromwell Lane for proposed pipeline construction. No culvert required, build off road entrance area with gravel as shown in the drawing.

Thanks,

Scott

**BULLITT COUNTY ENCROACHMENT PERMIT
FOR TILE PLACEMENT ON COUNTY MAINTAINED ROADS**

Issued by
**BULLITT COUNTY ROAD DEPARTMENT
1679 SOUTH PRESTON HWY.
P.O. BOX 768
SHEPHERDSVILLE, KY 40165
PHONE: 502-543-2510 FAX PHONE: 502-543-6889**

Date: 02/19/2019

Permit No. 1491

Applicants Name: LOUISVILLE GAS AND ELECTRIC COMPANY

Applicants Address: 6900 Enterprise Drive, Louisville, KY 40214

Applicants Phone Number: [REDACTED] Cell#: _____

529 Cromwell Lane, Shepherdville, KY 40165
Temporary Entrance at Cromwell Ln. (CR-1110) Mile Post: 0.403
LONG: -85.56028495 LAT: 37.98054016

Location of Installation: _____

Signature of Applicant: *Dillon Groff*

*By signing above, I hereby certify and affirm that I am the wonder or legal occupant of the above-referenced property pursuant to Ordinance No. 86-24 VIA EASEMENT RIGHTS
NOTIFICATION DATE FOR SIZES WAS 5 MAR. 19*

Size of tile to be installed with approval of the Bullitt County Road Department.

Diameter: 8" LENGTH 20"

No tile to be installed less than fifteen (15) inches in diameter and twenty (20) feet in length unless approval is given by the Road Dept. No plastic PVC tiles are to be installed, only galvanized, concrete, or steel will be approved.

ON SITE _____

Date Tile Installed: _____

INSTALLED BY _____

METAL OR CONCRETE _____

COUNTY ROAD SUPERINTENDENT *[Signature]*

LG&E Bullitt County Pipeline Project
Access Road



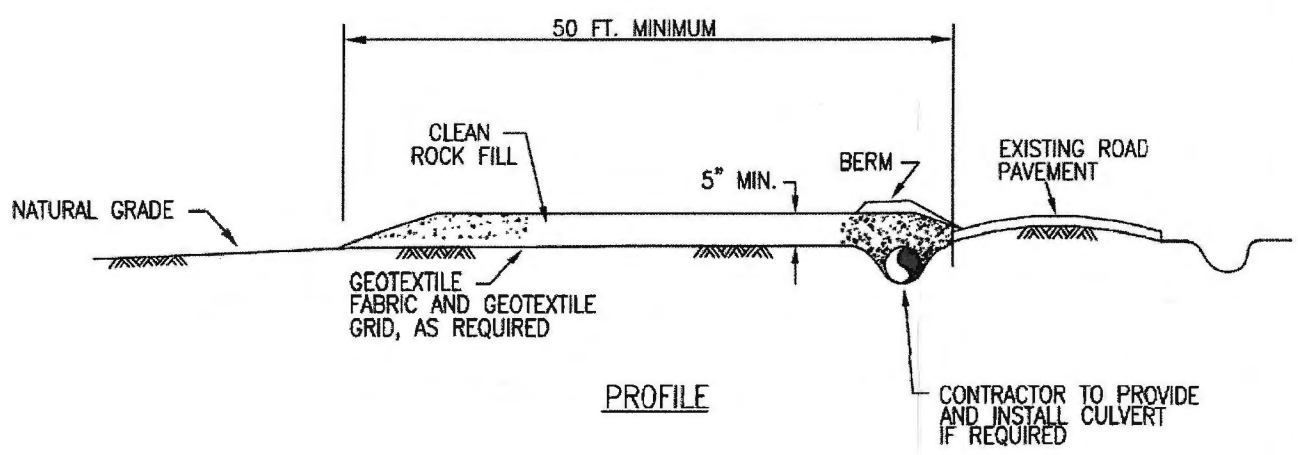
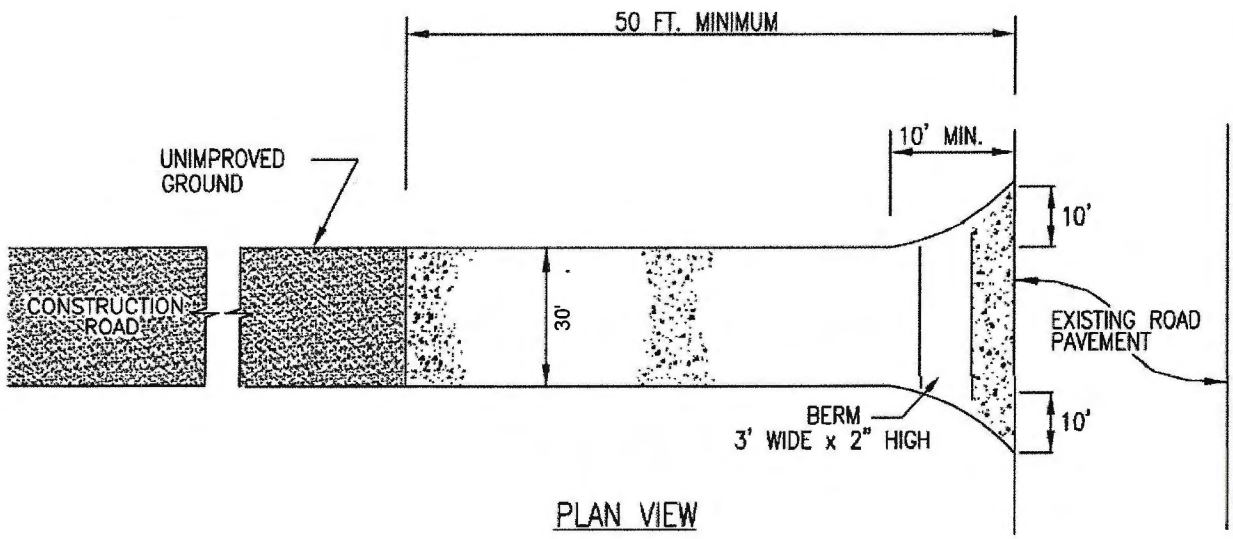

NOTES:

1. ACCESS PADS, AS ILLUSTRATED ABOVE, ARE TO BE INSTALLED ADJACENT TO EXISTING PAVED ROADS AT LOCATIONS IDENTIFIED ON THE CONSTRUCTION DRAWINGS OR AS DIRECTED BY THE COMPANY'S INSPECTOR.
2. IF USED IN AGRICULTURAL LAND, ROCK SHALL BE PLACED ON A GEOTEXTILE FABRIC TO FACILITATE ROCK REMOVAL.
3. SHOULD THE ROCK PAD BECOME INEFFECTIVE FOR REDUCING THE BUILDUP OF MUD AND DIRT AND MINIMIZING TRACKING ONTO THE PAVED ROAD, THE CONTRACTOR SHALL WASH THE EXISTING ROCK FILL SURFACE OR ADD A ROCK FILL LAYER TO THE ACCESS PAD.
4. CONTRACTOR SHALL KEEP PAVED ROAD SURFACES CLEAR OF MUD AND DEBRIS.
5. PRIOR TO PERMANENT SEEDING, CONTRACTOR SHALL REMOVE ALL IMPORTED ROCK FILL MATERIAL, GEOTEXTILE FABRIC AND CULVERT (IF INSTALLED) AND RESTORE THE GROUND TO NATURAL CONTOURS UNLESS OTHERWISE DIRECTED BY COMPANY'S INSPECTOR.

ENEngineering
 28100 TORCH PARKWAY
 WARRENVILLE, IL. 60555
 TEL. 630-353-4000
 FAX 630-353-7777
 WWW.ENENGINEERING.COM

DRAWN BY	BK (ENE)
CHECKED BY	MDW (ENE)
PROJECT ENG.	MDW (ENE)
APPROVED BY	DAD (ENE)
DATE	09-08-16
SCALE	N.T.S.

**TYPICAL STABILIZED
 CONSTRUCTION ENTRANCE**

LGE
 a PPL company

DRAWING:
EXHIBIT-04

MEMO

TO: Chris Music
Steve Beatty

FR: Scott Spidel

DA: 03-06-2019

RE: BC-18 Edwards TAR 12
Encroachment Permit No. 1492

Robert Watkins, Bullitt County Road Director agrees with the temporary entrance off of Cromwell Lane for proposed pipeline construction. No culvert required, build off road entrance area with gravel as shown in the drawing.

Thanks,

Scott

**BULLITT COUNTY ENCROACHMENT PERMIT
FOR TILE PLACEMENT ON COUNTY MAINTAINED ROADS**

Issued by
**BULLITT COUNTY ROAD DEPARTMENT
1679 SOUTH PRESTON HWY.
P.O. BOX 768
SHEPHERDSVILLE, KY 40165
PHONE: 502-543-2510 FAX PHONE: 502-543-6889**

Date: 02/19/2019

Permit No. 1492

Applicants Name: LOUISVILLE GAS AND ELECTRIC COMPANY

Applicants Address: 6900 Enterprise Drive, Louisville, KY 40214

Applicants Phone Number: [REDACTED] Cell#: _____

Location of Installation: West side of Cromwell across from 529 Cromwell Lane, Shepherdsville, KY 40165
Temporary Entrance at Cromwell Ln. (CR-1110) Mile Post: 0.403
LONG: -85.56028495 LAT: 37.98054016

Signature of Applicant: 

*By signing above, I hereby certify and affirm that I am the wonder or legal occupant of the above-referenced property pursuant to Ordinance No.86-24 VIA EASEMENT RIGHTS
NOTIFICATION DATE FOR SIZES WAS 5 MAR. 19*

Size of tile to be installed with approval of the Bullitt County Road Department.

Diameter: 8" LENGTH 20"

No tile to be installed less than fifteen (15) inches in diameter and twenty (20) feet in length unless approval is given by the Road Dept. No plastic PVC tiles are to be installed, only galvanized, concrete, or steel will be approved.

ON SITE _____

Date Tile Installed: _____

INSTALLED BY _____

METAL OR CONCRETE _____

COUNTY ROAD SUPERINTENDENT 

LG&E Bullitt County Pipeline Project
Access Road



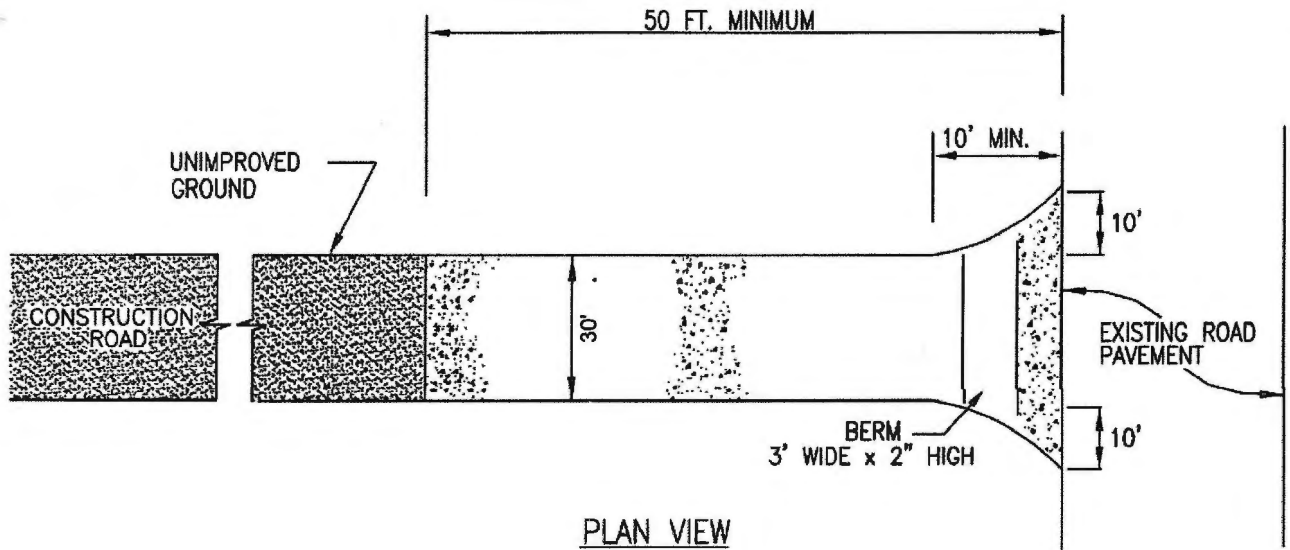

PLAN VIEW

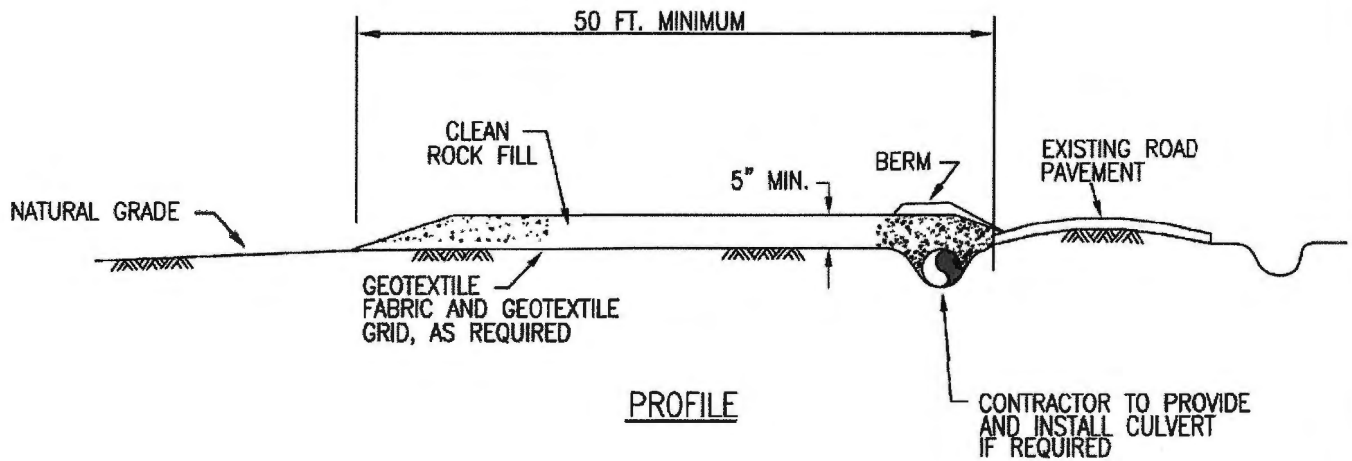

PROFILE

NOTES:

1. ACCESS PADS, AS ILLUSTRATED ABOVE, ARE TO BE INSTALLED ADJACENT TO EXISTING PAVED ROADS AT LOCATIONS IDENTIFIED ON THE CONSTRUCTION DRAWINGS OR AS DIRECTED BY THE COMPANY'S INSPECTOR.
2. IF USED IN AGRICULTURAL LAND, ROCK SHALL BE PLACED ON A GEOTEXTILE FABRIC TO FACILITATE ROCK REMOVAL.
3. SHOULD THE ROCK PAD BECOME INEFFECTIVE FOR REDUCING THE BUILDUP OF MUD AND DIRT AND MINIMIZING TRACKING ONTO THE PAVED ROAD, THE CONTRACTOR SHALL WASH THE EXISTING ROCK FILL SURFACE OR ADD A ROCK FILL LAYER TO THE ACCESS PAD.
4. CONTRACTOR SHALL KEEP PAVED ROAD SURFACES CLEAR OF MUD AND DEBRIS.
5. PRIOR TO PERMANENT SEEDING, CONTRACTOR SHALL REMOVE ALL IMPORTED ROCK FILL MATERIAL, GEOTEXTILE FABRIC AND CULVERT (IF INSTALLED) AND RESTORE THE GROUND TO NATURAL CONTOURS UNLESS OTHERWISE DIRECTED BY COMPANY'S INSPECTOR.

ENEngineering

28100 TORCH PARKWAY
WARRENVILLE, IL. 60555
TEL. 630-353-4000
FAX 630-353-7777
WWW.ENENGINEERING.COM

DRAWN BY	BK (ENE)
CHECKED BY	MDW (ENE)
PROJECT ENG.	MDW (ENE)
APPROVED BY	DAD (ENE)
DATE	09-06-16
SCALE	N.T.S.

**TYPICAL STABILIZED
CONSTRUCTION ENTRANCE**



a PPL company

DRAWING:

EXHIBIT-04