

**SPECIFICATIONS**  
**FOR**  
**NORTHERN KENTUCKY**  
**WATER DISTRICT**

**Ohio River Pump Station No. 2**  
**Rehabilitation**

June 9, 2016

Issued for Bid



COMPILED BY:  
NORTHERN KENTUCKY WATER DISTRICT  
2835 Crescent Springs Road  
P.O. Box 18640  
Erlanger, Kentucky 41018

THIS PAGE LEFT INTENTIONALLY BLANK

# **S P E C I F I C A T I O N S**

**FOR**

**NORTHERN KENTUCKY WATER DISTRICT**

## **Ohio River Pump Station No. 2 Rehabilitation**

**June 9, 2016**

**Issued for Bid**

**GOVERNING BODY**

**COMMISSIONERS:**

**FRED A. MACKE, JR. – CHAIR  
CLYDE CUNNINGHAM - VICE-CHAIR  
DAVID M. SPAULDING ESQ. - SECRETARY  
DOUGLAS C. WAGNER - TREASURER  
ANDREW C. COLLINS - COMMISSIONER  
DR. PATRICIA SOMMERKAMP - COMMISSIONER**

**RON LOVAN, PRESIDENT/CEO**

**COMPILED BY:  
Northern Kentucky Water District  
2835 Crescent Springs Road  
P.O. Box 18640  
Erlanger, Kentucky 41018**

THIS PAGE LEFT INTENTIONALLY BLANK

**NORTHERN KENTUCKY WATER DISTRICT  
OHIO RIVER PUMPING STATION NO. 2 STRUCTURAL IMPROVEMENT PROJECT**

**TABLE OF CONTENTS**

<b><u>SECTION</u></b>	<b><u>PAGE NO.</u></b>
<b>DIVISION 00 - PROCUREMENT AND CONTRACTING REQUIREMENTS</b>	
00 0020 Invitation to Bid	00 1113-1 – 2
00 0100 Instructions to Bidders	00 2113-1 – 8
00 0300 Bid Form	00 4243-1 – 8
00 0310 Affidavit for Claiming Resident Bidder Status	00 0310-1
00 0460 Non-Collusion Affidavit	00 4313-1
00 0500 Agreement	00 4345-1 – 8
00 0700 Standard General Conditions	00 0700-1 – 62
00 0800 Supplementary Conditions	00 0800-1 – 14
<b>DIVISION 01 - GENERAL REQUIREMENTS</b>	
01 1030 Project Dates	01 1030-1 – 2
01 1100 Summary of Work	01 1100-1 – 6
01 1120 Suggested Sequence of Construction	01 1120-1 – 4
01 1125 Measurement and Payment	01 1125-1 – 4
01 1200 Major Equipment Suppliers	01 1200-1 – 2
01 2513 Substitution Procedures	01 2513-1 – 4
01 3119 Project Meetings	01 3119-1 – 4
01 3300 Submittal Procedures	01 3300-1 – 6
01 3523 Job Conditions	01 3523-1 – 2
01 3543 Environmental Protection & Special Controls	01 3543-1 – 4
01 4500 Quality Control	01 4500-1 – 2
01 5000 Temporary Facilities and Controls	01 5000-1 – 4
01 6000 Product Requirements	01 6000-1 – 4
01 7700 Closeout Procedures	01 7700-1 – 2
<b>DIVISION 02 – EXISTING CONDITIONS</b>	
02 4000 Demolition	04 4000-1 – 8
<b>DIVISION 03 - CONCRETE</b>	
03 1100 Concrete Forming	03 1100-1 – 6
03 1500 Concrete Accessories	03 1500-1 – 6
03 2000 Concrete Reinforcing	03 2000-1 – 8
03 3000 Cast-In-Place Concrete	03 3000-1 – 20
03 7000 Concrete Repair and Rehab	03 7000-1 – 10

## TABLE OF CONTENTS

### DIVISION 04 - MASONRY

04 0511	Mortaring and Grouting	04 0511-1 – 8
04 2000	Unit Masonry	04 2000-1 – 14

### DIVISION 05 - METALS

05 1200	Structural Steel Framing	05 1200-1 – 8
05 5000	Metal Fabrications	05 5000-1 – 8
05 5213	Pipe Railings	05 5213-1 – 6
05 5300	Metal Gratings	05 5300-1 – 10

### DIVISION 06 - WOODS, PLASTICS, AND COMPOSITES

06 1053	Miscellaneous Rough Carpentry	06 1053-1 – 4
06 6000	Plastic Fabrications	06 6000-1 – 6
06 7110	FRP Structural Shapes	06 7110-1 – 10

### DIVISION 7 - THERMAL AND MOISTURE PROTECTION

07 9200	Joint Sealants	07 9200-1 – 8
---------	----------------	---------------

### DIVISION 8 - OPENINGS

08 2710	Finish Hardware	08 2710-1 -10
08 3120	Floor, Pit and Sidewalk Hatches	08 3120-1 – 4
08 5113	Windows	08 5113-1 – 4
08 8813	Fire-Resistant Glazing	08 8813-1 – 4

### DIVISION 9 - FINISHES

09 9123	Interior Painting	09 9123-1 – 4
09 9620	High-Performance Coating – Containment Coating	09 9620-1 – 8

### DIVISION 23 - VENTILATION

23 0900	HVAC Control Systems	23 0900-1 – 4
---------	----------------------	---------------

### DIVISION 26 - ELECTRICAL

26 0500	General Requirements	26 0500-1 – 8
26 0519	Electrical Conductors and Cables	26 0519-1 – 4
26 2728	Local Safety Disconnect Switches	26 2726-1 – 2
26 5000	Lighting	26 5000-1 – 2

## TABLE OF CONTENTS

### DIVISION 40 - PROCESS INTEGRATION

40 1000	Process Equipment General Requirements	40 1000-1 – 16
40 1500	Process Piping	40 0513-1 – 18
40 3000	Valves: Basic Requirements	40 3000-1 – 6
40 9200	Cast Iron Sluice Gates	40 9200-1 – 8

### APPENDICES

- A**      **Hazardous Materials Investigations**
- B**      **Dive Inspection Report by Terracon performed 3-31-16, dated April 11, 2016**
- C**      **Permits**

**TABLE OF CONTENTS**

**THIS PAGE LEFT BLANK INTENTIONALLY**



**PROCUREMENT AND CONTRACTING  
REQUIREMENTS**

**THIS PAGE LEFT BLANK INTENTIONALLY**

Section 00020

INVITATION TO BID

Date: June 9, 2016

**PROJECT: Ohio River Pump Station No. 2 – Structural Rehabilitation**

SEALED BIDS WILL BE RECEIVED AT:

Northern Kentucky Water District (Owner)  
2835 Crescent Springs Road  
P.O. Box 18640  
Erlanger, Kentucky 41018

UNTIL: Date: June 30, 2016  
Time: 2:00 p.m., local time

At said place and time, and promptly thereafter, all Bids that have been duly received will be publicly opened and read aloud.

The proposed project involves the rehabilitation of an existing 144 year old raw water intake and pumping facility located within the Ohio River. The new Work is generally described as follows: various select demolition, new windows, new static trash rack, new inlet sluice gate, new suction inlet valve, new wet well platforms, installation of new lighting, installation of new ventilation equipment, replacement of the reinforced concrete operating room floor, miscellaneous new electrical work, various new carpentry work, and the rehabilitation of the foundation walls by tuckpointing and block replacement.

All Bids must be in accordance with the Instructions to Bidders and Contract Documents on file, and available for examination at: Northern Kentucky Water District, 2835 Crescent Springs Road, Erlanger, Kentucky, 41018; or Wade Trim, 895 Central Avenue, Suite 830, Cincinnati, OH 45202.

Copies of the Bidding Documents may be obtained from Wade Trim at the address indicated herein. Charges for all documents obtained will be made on the following basis:

	<u>Charge</u>
Complete set of Bidding Documents	\$ 35.00
Mailing and Handling (if requested)	\$ 25.00

Charges for Bidding Documents and mailing and handling, if applicable, will not be refunded.

Prospective Bidders may address written inquiries to Kenneth Kamper with Wade Trim (kkamper@wadetrim.com).

Bids will be received on a lump sum basis as described in the Contract Documents.

Bid security, in the form of a certified check or Bid Bond (insuring/bonding company shall be rated "A" by AM Best) in the amount of ten percent (10%) of the maximum total bid price, must accompany each Bid.

The Successful Bidder will be required to furnish a Construction Performance Bond and a Construction Payment Bond (insuring/bonding company shall be rated "A" by AM Best) as security for the faithful performance of the project and the payment of all bills and obligations arising from the performance of the Contract.

The Successful Bidder and all Subcontractors will be required to conform to the labor standards set forth in the Contract Documents. This project falls under the provisions of KRS 337.505 to 337.550 for prevailing wage rates.

Owner reserves the right to reject any or all Bids, including without limitation the right to reject any or all nonconforming, non-responsive, incomplete, unbalanced, or conditional Bids, to waive informalities, and to reject the Bid of any Bidder if Owner believes that it would not be in the best interest of Owner to make an award to that Bidder. Owner also reserves the right to negotiate with the apparent Successful Bidder to such an extent as may be determined by Owner.

A mandatory pre-bid conference will be held for prospective Bidders on June 15, 2016 at 10:30 a.m. at the Ohio River Pumping Station Number 2. The address is given in the Instructions to Bidders.

On request 72 hours in advance, Owner will provide each Bidder access to the site to conduct such investigations and tests as each Bidder deems necessary for submission of a Bid. Arrangements for site visits shall be made by calling Dave Enzweiler, Maintenance Supervisor with the Northern Kentucky Water District, at (859) 547-3265.

Minority Bidders are encouraged to bid.

Bids shall remain subject to acceptance for 120 days after the day of bid opening or for such longer period of time to which a Bidder may agree in writing upon request of the Owner. If a Contract is to be awarded, the Owner will give the Successful Bidder a Notice of Award during the period of time during which the Successful Bidder's bid remains subject to acceptance.

Amy Kramer, V.P. Engineering, Production & Distribution  
Northern Kentucky Water District

End of Section

Section 00100

INSTRUCTIONS TO BIDDERS

1. DEFINED TERMS. Terms used in these Instructions to Bidders will have the meanings indicated in the General Conditions and Supplementary Conditions. Additional terms used in these Instructions to Bidders have the meanings indicated below which are applicable to both the singular and plural thereof:

- A. *Bidder* - The individual or entity who submits a Bid directly to Owner.
- B. *Successful Bidder* - The lowest responsible Bidder submitting a responsive Bid to whom Owner (on the basis of Owner's evaluation as hereinafter provided) makes an award.

2. COPIES OF CONTRACT DOCUMENTS. Complete sets of Contract Documents must be used in preparing Bids; Bidder shall have sole responsibility for errors or misrepresentations resulting from the use of incomplete sets of Bidding Documents.

Owner and Engineer, in making copies of Bidding Documents available on the above terms, do so only for the purpose of obtaining Bids for the Work and do not confer a license or grant for any other use.

3. QUALIFICATIONS OF BIDDERS. To demonstrate Bidder's qualifications to perform the Work, within five days of Owner's request Bidder shall submit written evidence such as financial data, previous experience, present commitments, and such other data as may be requested by Owner. Bidders who have not, in the Owner's opinion, had sufficient experience in the size and type of work involved may not be considered.

Each Bid must contain evidence of Bidder's qualifications to transact business in the State of Kentucky or covenant to obtain such qualifications prior to award of the Contract. The Bidder's Organization Number from the Kentucky's Secretary of State and principal place of business as filed with Kentucky's Secretary of State must be included where applicable.

Each Bidder must be registered as a plan holder with the Issuing Office or Engineer on record in the advertised "Invitation to Bid". There shall be no substitution of bidders without proper registration with the Issuing Office or Engineer on record in the advertised "Invitation to Bid"

4. EXAMINATION OF CONTRACT DOCUMENTS AND SITE. It is the responsibility of each Bidder, before submitting a Bid, to:

- a. thoroughly examine and study the Instructions to Bidders and the Contract Documents, including any Addenda;
- b. visit the Site and become familiar with and satisfy Bidder as to the general, local, and site conditions that may affect cost, progress, performance, or furnishing of the Work;
- c. become familiar with and satisfy Bidder as to all federal, state, and local Laws and Regulations that may affect cost, progress, performance, or furnishing of the Work;

- d. agree at the time of submitting its Bid that no further examinations, investigations, explorations, tests, studies, or data are necessary for the determination of its Bid for performance of the Work at the price bid and within the times and in accordance with the other terms and conditions of the Contract Documents;
- e. correlate the information known to Bidder, information and observations obtained from visits to the Site, and all additional examinations, investigations, explorations, tests, studies, and data with the Contract Documents;
- f. promptly give Owner written notice of all conflicts, errors, ambiguities, or discrepancies that Bidder discovers in the Contract Documents and confirm that the written resolution thereof by Owner is acceptable to Bidder; and
- g. determine that the Contract Documents are generally sufficient to indicate and convey understanding of all terms and conditions for the performance of the Work.

4.01. Underground Facilities. Information and data shown or indicated in the Contract Documents with respect to existing Underground Facilities at or contiguous to the Site is based upon information and data furnished to Owner and Engineer by owners of such Underground Facilities, including Owner or others, and Owner and Engineer disclaim responsibility for the accuracy or completeness thereof, unless it is expressly provided otherwise in the Supplementary Conditions.

4.02. Additional Information. Before submitting a Bid, each Bidder may, at Bidder's own expense, make or obtain any additional examinations, investigations, explorations, tests, and studies and obtain any additional information and data which pertain to subsurface or physical conditions at or contiguous to the Site or otherwise, which may affect cost, progress, performance, or furnishing of the Work and which Bidder deems necessary to determine its Bid for performing and furnishing the Work in accordance with the time, price, and other terms and conditions of the Contract Documents. Each Bidder shall be responsible for any claims for personal injury, death or damage to property caused by Bidder's entry on public or private property and shall defend and indemnify Owner and all other parties against any such claims.

4.03. Bidder's Representation. The submission of a Bid will constitute an incontrovertible representation and covenant by Bidder that Bidder has complied with every requirement of this Article 4, that without exception the Bid is premised upon performing and furnishing the Work required by the Contract Documents and applying any specific means, methods, techniques, sequences, and procedures of construction that may be shown or indicated or expressly required by the Contract Documents, that Bidder has given Owner written notice of all conflicts, errors, ambiguities, and discrepancies that Bidder has discovered in the Contract Documents and the written resolutions thereof are acceptable to Bidder, and that the Contract Documents are generally sufficient to indicate and convey understanding of all terms and conditions for performing and furnishing the Work.

5. PREBID CONFERENCE. A mandatory pre-bid conference will be held for prospective Bidders on June 15, 2016 at 10:30 a.m. at the Ohio River Pumping Station Number 2 which is located at 611 Mary Ingles Highway, Fort Thomas, Kentucky, which is approximately 1.75 miles north of the Interstate 275 Bridge over Kentucky State Route 8 (Mary Ingles Highway).

Representatives of the Owner and Engineer will be present to discuss the Project. Bidders are encouraged to attend and participate in the conference. Following the pre-bid conference meeting, bidders will be allowed to view the site. The site is secured and access at other times will require prospective Bidders to contact the District. Arrangements for site visits shall be made by calling Dave Enzweiler, Maintenance Supervisor with the Northern Kentucky Water District, at (859) 547-3265, 72 hours in advance. The Engineer will transmit to prospective Bidders of record such Addenda as the Engineer considers necessary in response to questions arising at the conference. Oral statements may not be relied upon and will not be binding or legally effective.

6. SITE AND OTHER AREAS. The Site is identified in the Contract Documents. All additional lands and access thereto required for temporary construction facilities, construction equipment, or storage of materials and equipment to be incorporated in the Work are to be obtained and paid for by Contractor. Easements for permanent structures or permanent changes in existing facilities are to be obtained and paid for by Owner unless otherwise provided in the Contract Documents.

7. INTERPRETATIONS AND ADDENDA. All questions about the meaning or intent of the Bidding Documents are to be submitted to Owner in writing. Any interpretations or clarifications that are considered necessary by Owner in response to such questions will be issued by Addenda mailed or delivered to all parties recorded by Owner as having received the Bidding Documents. Questions received less than seven (7) days prior to the date for opening of Bids may not be answered. The person submitting questions shall be responsible for their prompt delivery. Only questions answered by Addenda will be binding. Oral and other interpretations or clarifications will be without legal effect.

Addenda may be issued to clarify, correct, or change the Bidding Documents as deemed advisable by Owner or Engineer.

Owner will not be responsible for explanations or interpretations of the Bidding Documents or Contract Documents except as issued in accordance herewith.

8. BID SECURITY. Each Bid must be accompanied by Bid security made payable to Owner in an amount of 10 percent of Bidder's maximum Bid price and in the form of a Bid Bond (on the form attached) issued by a surety meeting the requirements of paragraphs 5.01 and 5.02 of the General Conditions and shall be rated "A" by AM BEST.

Bid security of the Successful Bidder will be retained until such Bidder has executed the Contract Documents, furnished the required contract security, and met the other conditions of the Notice of Award, whereupon the Bid security will be returned. If the Successful Bidder fails to execute and deliver the Contract Documents and furnish the required contract security within 15 days after the Notice of Award, Owner may annul the Notice of Award and Bid security of that Bidder will be forfeited. Bid security of other Bidders whom Owner believes to have a reasonable chance of receiving the award may be retained by Owner until the earlier of seven days after the Effective Date of the Agreement or one day after the last day the Bids remain subject to acceptance, whereupon Bid security furnished by such Bidders will be returned.

9. CONTRACT TIMES. The numbers of days within which, or the dates by which, the Work is to be (a) Substantially Completed and (b) also completed and ready for final payment are set forth in the Agreement.

10. LIQUIDATED DAMAGES. Provisions for liquidated damages, if any, are set forth in the Agreement.

11. SUBSTITUTE OR "OR-EQUAL" ITEMS. The Contract, if awarded, will be on the basis of materials and equipment specified or described in the Bidding Documents without consideration of possible substitute or "or-equal" items. Whenever it is specified or described in the Bidding Documents that a substitute or "or-equal" item of material or equipment may be furnished or used by Contractor if acceptable to Owner, application for such acceptance will not be considered by Owner until after the Effective Date of the Agreement. The procedure for submission of any such application by Contractor and consideration by Owner is set forth in the General Conditions and may be supplemented in the General Requirements.

12. PREPARATION OF BID. The Bid form is included with the Bidding Documents. Additional copies may be obtained from Owner.

All blanks on the Bid form shall be completed by printing in ink or by typewriter and the Bid signed. A Bid price shall be indicated for each lump sum bid item and/or unit price item listed therein, or the words "No Bid", "No Change", or "Not Applicable" entered.

A Bid by a corporation shall be executed in the corporate name by the president or a vice-president or other corporate officer accompanied by evidence of authority to sign. The corporate seal shall be affixed and attested by the secretary or an assistant secretary. The corporate address and state of incorporation shall be shown below the signature.

A Bid by a partnership shall be executed in the partnership name and signed by a partner (whose title must appear under the signature), accompanied by evidence of authority to sign. The official address of the partnership shall be shown below the signature.

A Bid by a limited liability company shall be executed in the name of the firm by a member (if member-managed) or manager (if manager-managed) and accompanied by evidence of authority to sign. The state of formation of the firm and the official address of the firm must be shown below the signature.

A Bid by an individual shall show the Bidder's name and official address.

A Bid by a joint venture shall be executed by each joint venturer in the manner indicated on the Bid form. The official address of the joint venture must be shown below the signature.

All names shall be typed or printed in ink below the signatures.

The Bid shall contain an acknowledgment of receipt of all Addenda, the numbers of which shall be filled in on the Bid form.

The address and telephone number for communications regarding the Bid shall be shown.



The Bid shall identify whether the Bidder is a resident or nonresident bidder for purposes of Kentucky's reciprocal preference statute (KRS 45A.490 to 45A.494 and 200 KAR 5:400). If the Bidder is claiming a "resident bidder" status as defined in KRS 45A.494(2), the Bid shall include a properly executed and notarized affidavit affirming that it meets the criteria to be considered such a resident bidder. If requested by Owner, Bidder shall also provide documentation proving such resident bidder status; failure to do so shall result in disqualification of the Bidder or contract termination.

While the Bidder should consult the applicable statutes and regulation, generally speaking, a "resident bidder" is an individual or business entity that, on the date the contract is first advertised or announced as available for bidding: (a) is authorized to transact business in the Commonwealth; AND (b) has for one (1) year prior to and through the date of the advertisement, (i) filed Kentucky corporate income taxes, (ii) made payments to the Kentucky unemployment insurance fund established in KRS 341.490, and (iii) maintained a Kentucky workers' compensation policy in effect. A "nonresident bidder" is any other individual or business entity.

13. BASIS OF BID. Bidders shall submit a Bid on a lump sum basis. Discrepancies between words and figures will be resolved in favor of the words.

14. SUBMITTAL OF BID. A Bid shall be submitted no later than the date and time prescribed and at the place indicated in the advertisement or invitation to Bid and shall be enclosed in an opaque sealed envelope plainly marked with the Project title, the name and address of Bidder, and shall be accompanied by the Bid security and other required documents. If a Bid is sent by mail or other delivery system, the sealed envelope containing the Bid shall be enclosed in a separate envelope plainly marked on the outside with the notation "Bid Enclosed".

Bids shall be addressed to Owner at:

Northern Kentucky Water District (Owner)  
2835 Crescent Springs Road  
P.O. Box 18640  
Erlanger, Kentucky 41018

One complete and executed Bid Form along with "Non-Collusion Affidavit", "Resident Bidder Status Affidavit", if applicable, Supplements to Bid Form, and Bid Bond shall be submitted. Bids shall be typed or in ink. Bidder shall assume full responsibility for timely delivery at the location designated for receipt of Bids. Bids received after the time and date for receipt of Bids may be returned unopened. Oral, telephone, facsimile, or telegraph Bids are invalid and will not receive consideration.

15. MODIFICATION AND WITHDRAWAL OF BIDS. A Bid may be modified or withdrawn by an appropriate document duly executed in the manner that a Bid must be executed and delivered to the place where Bids are to be submitted prior to the date and time for the opening of Bids. For a period ending 72 hours after Bids are opened, any Bidder may request the withdrawal of its Bid by filing with Owner a duly signed written notice and otherwise demonstrating by clear and convincing evidence to the reasonable satisfaction of Owner that the Bid was submitted in good faith but there was a material and/or substantial mistake in the

preparation of its Bid. If the withdrawal of the Bid is approved by the Owner in its sole discretion, the Bid security will be returned. Without the advanced full disclosure by the withdrawing Bidder to and written consent of the Owner, (a) no Bid shall be withdrawn under this section when the result would be the awarding of the contract on another Bid of the same Bidder or of another Bidder in which the withdrawing Bidder has a direct or indirect equitable interest and (b) no Bidder who is permitted to withdraw a Bid shall, for compensation, supply any material or labor to or perform any subcontract or other work agreement for the Bidder to whom the contract is awarded or otherwise benefit, directly or indirectly, from the performance of the Project.

16. OPENING OF BIDS. Bids will be opened at the time and place indicated in the advertisement or Invitation to Bid and, unless obviously non-responsive, read aloud publicly. An abstract of the amounts of the base Bids and major alternates, if any, will be made available to Bidders after the opening of Bids.

17. BIDS TO REMAIN SUBJECT TO ACCEPTANCE. All Bids will remain subject to acceptance for the period of time stated in the Bid Form, but Owner may, in its sole discretion, release any Bid and return the Bid security prior to the end of this period.

18. AWARD OF CONTRACT. Owner reserves the right to reject any or all Bids, including without limitation, nonconforming, non-responsive, incomplete, unbalanced, or conditional Bids. Owner further reserves the right to reject the Bid of any Bidder which it finds, after reasonable inquiry and evaluation, to be non-responsive. Owner may also reject the Bid of any Bidder if Owner believes that it would not be in the best interest of the Owner to make an award to that Bidder. Owner also reserves the right to waive all informalities and to negotiate with the apparent Successful Bidder to such an extent as may be determined by Owner. The Owner also reserves the right to increase or decrease the quantities of work per the General Conditions.

In evaluating Bids, Owner will consider, among other lawful considerations, the following:

- a. Whether or not the Bid complies with the prescribed requirements, and provides such alternates, unit prices and other information or data as may be requested in the Bid Form or prior to the Notice of Award.
- b. The qualifications of the Bidder.
- c. If the Bidder maintains a permanent place of business.
- d. If the Bidder has adequate personnel, plant and equipment to perform the Work properly and expeditiously.
- e. Bidder's financial status to meet all obligations and incidentals to the Work.
- f. Whether the Bidder has appropriate technical expertise and experience.
- g. Bidder's performance record.
- h. The amount of the TOTAL BASE BID, exclusive of any additive alternates, if applicable. Any additive alternates will be considered after selection of the lowest Total Base Bid. Each additive alternate will be considered and selected or not selected individually, at Owner's discretion, for inclusion in the work.

In addition, the evaluation of Bids will be subject to the reciprocal preference for Kentucky resident bidders pursuant to KRS 45A.490 to 45A.494 and KAR 200 5:400. These statutes and regulation provide in part as follows: (a) a resident bidder of the Commonwealth shall be given a preference against a nonresident bidder registered in any state that gives or requires a preference to bidders from that state; (b) the preference shall be equal to the preference given or required by the state of the nonresident bidder; (c) this preference shall not be applied against nonresident bidders residing in states that do not give preference against Kentucky bidders; (d) if a procurement determination results in a tie between a resident bidder and a nonresident bidder, preference shall be given to the resident bidder; and (e) the preference shall not result in a nonresident bidder receiving a preference over another nonresident bidder.

Owner may conduct such investigations as Owner deems necessary to establish the responsibility, qualifications, and financial ability of Bidders to perform the Work in accordance with the Contract Documents, including, without limitation, a Bidder's claim that it is a resident bidder for purposes of Kentucky's preference statute.

19. CONTRACT SECURITY AND INSURANCE. Article 5 of the General Conditions, as may be modified by the Supplementary Conditions, sets forth Owner's requirements as to performance and payment Bonds and insurance. When the Successful Bidder delivers the executed Agreement to Owner, it must be accompanied by such Bonds.

20. SIGNING OF AGREEMENT. When Owner gives a Notice of Award to the Successful Bidder, it will be accompanied by the required number of unsigned counterparts of the Agreement with the other Contract Documents identified in the Agreement as attached thereto. Within 15 days thereafter, the Successful Bidder shall sign, leaving the dates blank, and deliver the required number of counterparts of the Agreement and attached documents to Owner. Within 15 days thereafter, Owner shall deliver one fully signed counterpart to Successful Bidder with a complete set of the Drawings with appropriate identification.

21. RETAINAGE. Provisions concerning retainage are set forth on the Agreement.

End of Section

THIS PAGE LEFT INTENTIONALLY BLANK

Section 00300

BID FORM

PROJECT IDENTIFICATION: **Ohio River Pump Station No. 2 Structural Rehabilitation**

THIS BID IS SUBMITTED TO:

Northern Kentucky Water District (Owner)  
P.O. Box 18640  
2835 Crescent Springs Road  
Erlanger, Kentucky 41018

THIS BID IS SUBMITTED BY: \_\_\_\_\_  
(Bidder's Company Name)

1. The undersigned Bidder proposes and agrees, if this Bid is accepted, to enter into an Agreement with Owner in the form included in the Contract Documents to perform all Work as specified or indicated in the Contract Documents for the prices and within the times indicated in this Bid and in accordance with the other terms and conditions of the Contract Documents.
2. Bidder accepts all of the terms and conditions of the Invitation to Bid and the Instructions to Bidders, including without limitation those dealing with the disposition of Bid security. This Bid will remain subject to acceptance for 120 days after the Bid opening, or for such longer period of time to which the Bidder may agree in writing upon request of Owner. Bidder understands that certain extensions to the time for acceptance of this Bid may require the consent of the surety for the Bid Bond.
3. In submitting this Bid, Bidder represents and covenants, as set forth in the Agreement, that:
  - a. Bidder has examined and carefully studied the Contract Documents, the other related data identified in the Contract Documents, and the following Addenda, receipt of all of which is hereby acknowledged:  
No. \_\_\_\_\_ Dated \_\_\_\_\_  
No. \_\_\_\_\_ Dated \_\_\_\_\_  
No. \_\_\_\_\_ Dated \_\_\_\_\_
  - b. Bidder has visited the Site and become familiar with and is satisfied as to the general, local, and Site conditions that may affect cost, progress, and performance of the Work.
  - c. Bidder is familiar with and is satisfied as to all federal, state, and local Laws and Regulations that may affect cost, progress, and performance of the Work.
  - d. Bidder has obtained and carefully studied (or assumes responsibility for having done so) all additional or supplementary explorations, investigations, explorations, tests, studies and data concerning conditions (surface, subsurface, and Underground Facilities) at or contiguous to the Site which may affect cost, progress, or

performance of the Work or which relate to any aspect of the means, methods, techniques, sequences, and procedures of construction to be employed by Bidder, including applying the specific means, methods, techniques, sequences, and procedures of construction expressly required by the Bidding Documents to be employed by Bidder, and safety precautions and programs incident thereto.

- e. Bidder does not consider that any further examinations, investigations, explorations, tests, studies, or data are necessary for the determination of this Bid for performance of the Work at the price(s) bid and within the times and in accordance with the other terms and conditions of the Bidding Documents.
- f. Bidder is aware of the general nature of work to be performed by Owner and others at the Site that relates to the Work as indicated in the Bidding Documents.
- g. Bidder has correlated the information known to Bidder, information and observations obtained from visits to the Site, reports and drawings identified in the Bidding Documents, and all additional examinations, investigations, explorations, tests, studies, and data with the Bidding Documents.
- h. Bidder has given Owner written notice of all conflicts, errors, ambiguities, or discrepancies that Bidder has discovered in the Bidding Documents, and the written resolution thereof by Owner is acceptable to Bidder.
- i. The Bidding Documents are generally sufficient to indicate and convey understanding of all terms and conditions for the performance of the Work for which this Bid is submitted.
- j. [Check the one that applies]

\_\_\_\_\_ Bidder is a “resident bidder” as defined in KRS 45A.494(2) of Kentucky’s resident bidder reciprocal preference statute AND submits with this Bid a properly executed and notarized Affidavit that affirms that Bidder meets the resident bidder criteria, which Affidavit is hereby incorporated herein and made a part of this Bid.

OR

\_\_\_\_\_ Bidder is a “nonresident bidder” as defined in KRS 45A.494(3) of Kentucky’s resident bidder reciprocal preference statute AND its principal place of business as identified its Certificate of Authority to transact business in Kentucky as filed with Kentucky’s Secretary of State or, if Bidder hereby represents and covenants that it is not required to obtain a Certificate of Authority to transact business in Kentucky, its mailing address, is:

\_\_\_\_\_  
\_\_\_\_\_  
\_\_\_\_\_

- k. Bidder's Organization Number from Kentucky's Secretary of State is #\_\_\_\_\_ [if applicable] and Bidder is qualified to transact business in the State of Kentucky or hereby covenants to obtain such qualifications prior to award of the Contract.
4. Bidder further represents that this Bid is genuine and not made in the interest of or on behalf of any undisclosed individual or entity and is not submitted in conformity with any agreement or rules of any group, association, organization, or corporation; Bidder has not directly or indirectly induced or solicited any other Bidder to submit a false or sham Bid; Bidder has not solicited or induced any individual or entity to refrain from bidding; and Bidder has not sought by collusion to obtain for itself any advantage over any other Bidder or over Owner.
5. The Bidder understands and agrees that during the performance of the Contract, it shall maintain a presence within such proximity of the Site which will allow it to respond to an emergency at the Site within one hour of receiving notice of an emergency, including emergencies occurring during non-working hours. The Bidder shall provide a list of emergency phone numbers for such purposes. If the Bidder does not have such a presence, it may satisfy this requirement by sub-contracting with a sub-contractor that does have such a presence, provided that any such sub-contractor must be approved by the Owner, in its sole discretion, prior to the project pre-construction meeting.
6. Bidder will complete the work based on the following schedule.

No.	Item	Unit	Quantity	Unit Price	Item Price
1	Mobilization (to be no more than 3% of total price)	LS	1		
2	Foundation Tuck Pointing	LF	5,400		
3	Foundation Block Replacement	LF	200		
4	Pump Station Rehabilitation	LS	1		
5	Contingency Allowance	LS	1	\$250,000	\$250,000
<b>6</b>	<b>Total</b>				

7. Bidder will complete the Work for the following price:

Lump Sum Bid of \$ \_\_\_\_\_ in  
 numbers and \_\_\_\_\_  
 in words.

8. Bidder agrees that the Work will be substantially complete within 365 calendar days after the date when the Contract Times commence to run as provided in paragraph 2.03 (A) of the General Conditions, and completed and ready for final payment in accordance with Article 14 of the General Conditions within 395 calendar days after the date when the Contract Times commence to run.

The terms used in this Bid with initial capital letters have the meanings indicated in the Instructions to Bidders, the General Conditions, and the Supplementary Conditions.

9. References

Contact Person	Company Name	Phone No.	Project Name
1.	_____	_____	_____
2.	_____	_____	_____
3.	_____	_____	_____
4.	_____	_____	_____

SUBMITTED on \_\_\_\_\_, 2016.

10. Communications concerning this Bid shall be sent to Bidder at the following address:

\_\_\_\_\_  
\_\_\_\_\_  
\_\_\_\_\_  
\_\_\_\_\_

11. The terms in this Bid, which are defined in the General Conditions included as part of the Contract Documents, have the meanings assigned to them in the General Conditions.



**SIGNATURE OF BIDDER**

**If an Individual**

Name (typed or printed): \_\_\_\_\_

By \_\_\_\_\_ (SEAL)  
*(Individual's signature)*

doing business as \_\_\_\_\_

Business address \_\_\_\_\_

\_\_\_\_\_

Phone No.: \_\_\_\_\_ Fax No.: \_\_\_\_\_

Date \_\_\_\_\_

**If a Partnership**

Partnership Name: \_\_\_\_\_ (SEAL)

By \_\_\_\_\_  
*(Signature of general partner - attach evidence of authority to sign)*

Name (typed or printed): \_\_\_\_\_

Business address \_\_\_\_\_

\_\_\_\_\_

Phone No. \_\_\_\_\_ Fax No.: \_\_\_\_\_

Date \_\_\_\_\_

**If a Corporation**

Corporation Name: \_\_\_\_\_ (SEAL)

State of Incorporation: \_\_\_\_\_

Type (General, Professional Service): \_\_\_\_\_

By \_\_\_\_\_  
*(Signature - attach evidence of authority to sign)*

Name (typed or printed): \_\_\_\_\_

Title: \_\_\_\_\_ (CORPORATE SEAL)

Attest \_\_\_\_\_

Business address \_\_\_\_\_

\_\_\_\_\_

Phone No. \_\_\_\_\_ Fax No.: \_\_\_\_\_

Date \_\_\_\_\_

**If a Limited Liability Company**

Company Name: \_\_\_\_\_ (SEAL)

State of Organization: \_\_\_\_\_

Type (General, Professional): \_\_\_\_\_

By \_\_\_\_\_  
*Signature of Member or Manager (as applicable)- attach evidence of authority to sign)*

Name (typed or printed): \_\_\_\_\_

Title: \_\_\_\_\_ (COMPANY SEAL)

Attest \_\_\_\_\_

Business address \_\_\_\_\_

\_\_\_\_\_

Phone No. \_\_\_\_\_ Fax No.: \_\_\_\_\_

Date \_\_\_\_\_

**If a Joint Venture**

(Each joint venturer must sign. The manner for signing for each individual, partnership, and corporation that is party to the joint venture should be in the manner indicated above.)

Joint Venturer Name: \_\_\_\_\_ (SEAL)

By: \_\_\_\_\_  
*(Signature - attach evidence of authority to sign)*

Name (typed or printed): \_\_\_\_\_

Title: \_\_\_\_\_

Business address: \_\_\_\_\_

\_\_\_\_\_

Phone No.: \_\_\_\_\_ Fax No.: \_\_\_\_\_

Date \_\_\_\_\_

Joint Venturer Name: \_\_\_\_\_ (SEAL)

By: \_\_\_\_\_  
*(Signature - attach evidence of authority to sign)*

Name (typed or printed): \_\_\_\_\_

Title: \_\_\_\_\_

Business address: \_\_\_\_\_

\_\_\_\_\_

Phone No.: \_\_\_\_\_ Fax No.: \_\_\_\_\_

Date \_\_\_\_\_

THIS PAGE LEFT INTENTIONALLY BLANK

**Bid Description: Ohio River Pump Station No. 2 Rehabilitation**

**REQUIRED NOTARIZED AFFIDAVIT FOR BIDDERS, OFFERORS AND CONTRACTORS CLAIMING KENTUCKY RESIDENT BIDDER STATUS**

**FOR BIDS AND CONTRACTS IN GENERAL:**

The bidder or offeror hereby swears and affirms under penalty of perjury that, in accordance with KRS 45A.494(2), the entity bidding is an individual, partnership, association, corporation, or other business entity that, on the date the contract was first advertised or announced as available for bidding:

1. Is authorized to transact business in the Commonwealth of Kentucky; AND
2. Has for one year prior to and through the date this contract was first advertised or announced as available for bidding:
  - a. Filed Kentucky corporate income taxes;
  - b. Made payments to the Kentucky unemployment insurance fund established in KRS 341.490; and
  - c. Maintained a Kentucky workers' compensation policy in effect.

The undersigned acknowledges that the District reserves the right to request documentation supporting a bidder's claim of resident bidder status. Failure to provide such documentation upon request shall result in disqualification of the bidder or contract termination.

\_\_\_\_\_  
Signature

\_\_\_\_\_  
Printed Name

\_\_\_\_\_  
Title (if signing on behalf of an entity)

\_\_\_\_\_  
Date

**State of** \_\_\_\_\_ )  
 )ss.

**County of** \_\_\_\_\_ )

Subscribed and sworn to before me by \_\_\_\_\_, as the  
\_\_\_\_\_, of \_\_\_\_\_, this \_\_\_\_\_ day of  
\_\_\_\_\_, 2016.

\_\_\_\_\_  
Notary-at-Large  
My comm. exp.: \_\_\_\_\_

THIS PAGE LEFT INTENTIONALLY BLANK

Section 00460

NON-COLLUSION AFFIDAVIT

STATE OF: \_\_\_\_\_ )

COUNTY OF: \_\_\_\_\_ ) SS

\_\_\_\_\_, being first duly sworn, deposes

and says that he/she is the \_\_\_\_\_ of  
(sole owner, a partner, president, secretary, etc.)

\_\_\_\_\_, the party making the foregoing bid; that such bid is genuine and not collusive or sham; that said bidder is not financially interested in, or otherwise affiliated in a business way with any other bidder on the same contract; that said bidder has not colluded, conspired, connived, or agreed, directly or indirectly, with any bidder or person, to put in a sham bid, or that such other person shall refrain from bidding, and has not in any manner directly or indirectly sought by agreement or collusion, or communication or conference, with any person, to fix the price or affidavit of any other bidder, or that of any other bidder, or to secure any advantage against Owner, or any person or persons interested in the proposed Contract; and that all statements contained in said bid are true; and further, that such bidder has not, directly or indirectly submitted this bid, or the contents thereof, or divulged information of data relative thereto to any association or to any member or agent thereof.

\_\_\_\_\_  
AFFIANT

Sworn to and subscribed before me, a Notary Public in and for the above named

State and County, this \_\_\_\_\_ day of \_\_\_\_\_, 20 \_\_\_\_\_.

\_\_\_\_\_  
NOTARY PUBLIC

End of Section

THIS PAGE LEFT INTENTIONALLY BLANK



*(Note: The following standard form will be used for the)  
(preparation of the Agreement, after award of contract.)*

Section 00500

AGREEMENT

THIS AGREEMENT is made and entered by and between the Northern Kentucky Water District (herein called Owner) and \_\_\_\_\_ (herein called Contractor).

Owner and Contractor, in consideration of the mutual covenants herein set forth, agree as follows:

Article 1. WORK.

Contractor shall complete all Work as specified or indicated in the Contract Documents. The Work is generally described as follows:

Construction of improvements to demolish the existing building at the Dudley complex and constructing a new building to house the sodium hypochlorite equipment. The project will also include new buried chemical feed piping and electrical connections to the existing pumping station.

Article 2. ENGINEER.

The Project has been designed by Wade Trim, 895 Central Avenue, Suite 830, Cincinnati, OH, 45202, who is referred to in the Contract Documents as Engineer. Engineer, and its duly authorized agents, are to act as Owner's representative, assume all duties and responsibilities, and have the rights and authority assigned to Engineer in the Contract Documents in connection with completion of the Work in accordance with the Contract Documents.

Article 3. CONTRACT TIMES, LIQUIDATED DAMAGES, DELAYS, AND DAMAGES.

All time limits for Milestones, if any, Substantial Completion, and completion and readiness for final payment as stated in the Contract Documents are of the essence of the Contract.

3.1. Contract Times. The Work will be substantially completed within 365 days after the date when the Contract Times commence to run as provided in paragraph 2.03.A of the General Conditions, and completed and ready for final payment in accordance with Article 14 of the General Conditions within 395 days after the date when the Contract Times commence to run.

3.2. Liquidated Damages. Owner and Contractor recognize that time is of the essence of this Agreement and that Owner will suffer financial loss if the Work is not completed within the times specified in paragraph 3.1 above, plus any extensions thereof allowed in accordance with Article 12 of the General Conditions. The parties also recognize the delays, expenses, and difficulties involved in proving in a legal proceeding the actual loss suffered by Owner if the Work is not completed on time. Accordingly, instead of requiring any such proof, Owner and Contractor agree

that as liquidated damages for delay (but not as a penalty), Contractor shall pay Owner \$750.00 for each day that expires after the time specified in paragraph 3.1 for Substantial Completion until the Work is substantially complete. After Substantial Completion, if Contractor shall neglect, refuse, or fail to complete the remaining Work within the Contract Times or any proper extension thereof granted by Owner, Contractor shall pay Owner as liquidated damages (but not as a penalty) \$500.00 for each day that expires after the time specified in paragraph 3.1 for completion and readiness for final payment until the Work is completed and ready for final payment.

Owner shall have the right to deduct the liquidated damages from any money in its hands, otherwise due, or to become due, to Contractor, or to initiate action to recover liquidated damages for nonperformance of this Contract within the time stipulated.

3.3. Delays and Damages. In the event Contractor is delayed in the prosecution and completion of the Work because of any delays caused by Owner or Engineer, Contractor shall have no claim against Owner or Engineer for damages (including but not limited to acceleration costs or damages) or contract adjustment other than an extension of the Contract Times and the waiving of liquidated damages during the period occasioned by the delay.

Contractor shall provide advance written notice to Owner and Engineer of Contractor's intention to accelerate the Work prior to commencing any acceleration. Such written notice shall include a detailed explanation of the nature and scope of the acceleration, the reason for the acceleration, the anticipated duration of the acceleration, and the estimated additional costs to Contractor, if any, related to the acceleration. This requirement shall not in any way affect or alter the agreement of Owner and Contractor with respect to delays and damages as set forth above and in the General Conditions and Supplementary Conditions. Owner shall not be responsible or liable for any acceleration costs or damages.

Article 4. CONTRACT PRICE.

Owner shall pay Contractor for completion of the Work in accordance with the Contract Documents funds a total amount of:

\_\_\_\_\_ (\$ \_\_\_\_\_ )  
(words) (figures)

as indicated in Contractor's bid.

Article 5. PAYMENT PROCEDURES.

Contractor shall submit Applications for Payment in accordance with Article 14 of the General Conditions. Applications for Payment will be processed by Engineer as provided in the General Conditions and as modified by the Supplementary Conditions.

5.1. Progress Payments. Owner shall make progress payments on account of the Contract Price on the basis of Contractor's Applications for Payment as recommended by the Engineer monthly during construction as provided in the General Conditions. All progress payments will be on the basis of the progress of the work measured by the schedule of values established in accordance

with paragraph 2.07.A of the General Conditions (and in the case of Unit Price Work based on the number of units completed).

5.2. Retainage. In addition to any amounts withheld from payment in accordance with Paragraph 14.02 of the General Conditions, Owner shall retain from progress payments amounts equal to the following percentages:

- a. Ten percent (10%) of the amount of the Work completed. This amount may be reduced by the Owner in its sole and absolute discretion, if the project is substantially completed; and
- b. Ten percent (10%) of the value of materials and equipment that are not incorporated in the Work but are delivered, suitably stored, and accompanied by documentation satisfactory to Owner as provided in paragraph 14.02.A.1 of the General Conditions. Retainage for stored materials and equipment will be released when the materials and equipment are incorporated in the Work.

All retainage will be paid to Contractor when the Work is completed and ready for final payment in accordance with paragraph 14.07.C of the General Conditions. Consent of the Surety shall be obtained before retainage is paid by Owner. Consent of the Surety, signed by an agent, must be accompanied by a certified copy of such agent's authority to act for the Surety.

5.3. Final Payment. Upon final completion and acceptance of the Work in accordance with paragraphs 14.07.B and 14.07. C. of the General Conditions, Owner shall pay the remainder of the Contract Price as provided in paragraph 14.07.B and 14.07.C.

## Article 6. CONTRACTOR'S REPRESENTATION

In order to induce Owner to enter into this Agreement, Contractor makes the following representations:

- a. Contractor has examined and carefully studied the Contract Documents and the other related data identified in the Contract Documents.
- b. Contractor has visited the Site and become familiar with and is satisfied as to the general, local, and Site conditions that may affect cost, progress, and performance of the Work.
- c. Contractor is familiar with and is satisfied as to all federal, state, and local Laws and Regulations that may affect cost, progress, and performance of the Work.
- d. Contractor has obtained and carefully studied (or assumes responsibility for having done so) all additional or supplementary explorations, investigations, explorations, tests, studies and data concerning conditions (surface, subsurface, and Underground Facilities) at or contiguous to the Site which may affect cost, progress, or performance of the Work or which relate to any aspect of the means, methods, techniques, sequences, and procedures of construction to be employed by

Contractor, including applying the specific means, methods, techniques, sequences, and procedures of construction, if any, expressly required by the Contract Documents to be employed by Contractor, and safety precautions and programs incident thereto.

- e. Contractor does not consider that any further examinations, investigations, explorations, tests, studies, or data are necessary for the performance of the Work at the Contract Price, within the Contract Times, and in accordance with the other terms and conditions of the Contract Documents.
- f. Contractor is aware of the general nature of work to be performed by Owner and others at the Site that relates to the Work as indicated in the Contract Documents.
- g. Contractor has correlated the information known to Contractor, information and observations obtained from visits to the Site, reports and drawings identified in the Contract Documents, and all additional examinations, investigations, explorations, tests, studies, and data with the Contract Documents.
- h. Contractor has given Owner written notice of all conflicts, errors, ambiguities, or discrepancies that Contractor has discovered in the Contract Documents, and the written resolution thereof by Owner is acceptable to Contractor.
- i. The Contract Documents are generally sufficient to indicate and convey understanding of all terms and conditions for performance and furnishing of the Work.

#### Article 7. CONTRACT DOCUMENTS.

The Contract Documents, which are incorporated as part of this Agreement, consist of the following:

- A. This Agreement;
- B. Performance Bond;
- C. Payment Bond;
- D. General Conditions;
- E. Supplementary Conditions;
- F. Specifications;
- G. Drawings consisting of a cover sheet and sheets numbered G-1 through E-2 inclusive, with each sheet bearing the following general title;  
Northern Kentucky Water District  
Ohio River Pumping Station No. 2 Structural Rehabilitation
- H. Addenda (numbers \_\_\_ to \_\_\_, inclusive);
- I. Exhibits to this Agreement (enumerated as follows):
  - 1. Notice of Award and Notice to Proceed;
  - 2. Contractor's Bid;
  - 3. Documentation submitted by Contractor prior to Notice of Award;
- J. The following which may be delivered or issued on or after the Effective Date of the Agreement and are not attached hereto:
  - 1. Written Amendments;

2. Work Change Directives;
3. Change Orders.

There are no Contract Documents other than those listed above in this Article 7. The Contract Documents may only be amended, modified, or supplemented as provided in paragraph 3.04.A and 3.04.B of the General Conditions.

#### Article 8. COMPLIANCE WITH KENTUCKY LAW

Contractor represents and warrants that it has revealed to Owner any and all final determinations of a violation of KRS Chapters 136, 139, 141, 337, 338, 341, and 342 by Contractor or any subcontractor within the past five years. Contractor further represents and warrants that it and each of its subcontractors will remain in continuous compliance with the provisions of KRS Chapters 136, 139, 141, 337, 338, 341 and 342 for the duration of this Agreement. Contractor understands that its failure to reveal a final determination of a violation or to comply with the above statutory requirements constitutes grounds for cancellation of the Agreement and for disqualification of Contractor from eligibility for any contracts for a period of two years.

#### Article 9. EQUAL OPPORTUNITY

Unless exempted under KRS 45.590, during the performance of this Agreement, Contractor agrees as follows:

1. Contractor will not discriminate against any employee or applicant for employment because of race, color, religion, sex, age forty (40) and over, disability, veteran status, or national origin;
2. Contractor will take affirmative action in regard to employment, upgrading, demotion, transfer, recruitment, recruitment advertising, layoff, termination, rates of pay or other forms of compensation, and selection for training, so as to ensure that applicants are employed and that employees during employment are treated without regard to their race, color, religion, sex, age forty (40) and over, disability, veteran status, or national origin;
3. Contractor will state in all solicitations or advertisements for employees placed by or on behalf of Contractor that all qualified applicants will receive consideration for employment without regard to race, color, religion, sex, age forty (40) or over, disability, veteran status, or national origin;
4. Contractor will post notices in conspicuous places, available to employees and applicants for employment, setting forth the provisions of the nondiscrimination clauses required by this section; and
5. Contractor will send a notice to each labor union or representative of workers with which he has a collective bargaining agreement or other contract or

understanding advising the labor union or workers' representative of Contractor's commitments under the nondiscrimination clauses.

Article 10. MISCELLANEOUS.

- a. Terms used in this Agreement will have the meanings indicated in the General Conditions.
- b. No assignment by a party hereto of any rights under or interests in the Contract will be binding on another party hereto without the written consent of the party sought to be bound; and, specifically but without limitation, moneys that may become due and moneys that are due may not be assigned without such consent (except to the extent that the effect of this restriction may be limited by law), and unless specifically stated to the contrary in any written consent to an assignment, no assignment will release or discharge the assignor from any duty or responsibility under the Contract Documents.
- c. Owner and Contractor each binds itself, its partners, successors, assigns, and representatives to the other party hereto, its partners, successors, assigns, and representatives in respect of all covenants, agreements, and obligations contained in the Contract Documents.
- d. Any provision or part of the Contract Documents held to be void or unenforceable under any Law or Regulation shall be deemed stricken, and all remaining provisions shall continue to be valid and binding upon Owner and Contractor, who agree that the Contract Documents shall be reformed to replace such stricken provision or part thereof with a valid and enforceable provision that comes as close as possible to expressing the intention of the stricken provision.

IN WITNESS WHEREOF, Owner and Contractor have signed this Agreement. One counterpart each has been delivered to Owner, Contractor, Surety, and Engineer.

This Agreement will be effective on \_\_\_\_\_ (which is the Effective Date of the Agreement).

OWNER: Northern Kentucky Water District

\_\_\_\_\_

By: \_\_\_\_\_

Address for giving notices

2835 Crescent Springs Road  
P.O. Box 18640  
Erlanger, Kentucky 41018

CONTRACTOR: \_\_\_\_\_

By: \_\_\_\_\_

(Corporate Seal)

Address for giving notices

\_\_\_\_\_  
\_\_\_\_\_

*(If Contractor is a corporation, attach evidence of authority to sign.)*

THIS PAGE LEFT INTENTIONALLY BLANK



This document has important legal consequences; consultation with an attorney is encouraged with respect to its use or modification. This document should be adapted to the particular circumstances of the contemplated Project and the controlling Laws and Regulations.

# STANDARD GENERAL CONDITIONS OF THE CONSTRUCTION CONTRACT

Prepared by

**ENGINEERS JOINT CONTRACT DOCUMENTS COMMITTEE**

and

Issued and Published Jointly by



AMERICAN COUNCIL OF ENGINEERING COMPANIES

ASSOCIATED GENERAL CONTRACTORS OF AMERICA

AMERICAN SOCIETY OF CIVIL ENGINEERS

PROFESSIONAL ENGINEERS IN PRIVATE PRACTICE  
*A Practice Division of the*  
NATIONAL SOCIETY OF PROFESSIONAL ENGINEERS

Endorsed by



CONSTRUCTION SPECIFICATIONS INSTITUTE

These General Conditions have been prepared for use with the Suggested Forms of Agreement Between Owner and Contractor (EJCDC C-520 or C-525, 2007 Editions). Their provisions are interrelated and a change in one may necessitate a change in the other. Comments concerning their usage are contained in the Narrative Guide to the EJCDC Construction Documents (EJCDC C-001, 2007 Edition). For guidance in the preparation of Supplementary Conditions, see Guide to the Preparation of Supplementary Conditions (EJCDC C-800, 2007 Edition).

Copyright © 2007 National Society of Professional Engineers  
1420 King Street, Alexandria, VA 22314-2794  
(703) 684-2882  
[www.nspe.org](http://www.nspe.org)

American Council of Engineering Companies  
1015 15th Street N.W., Washington, DC 20005  
(202) 347-7474  
[www.acec.org](http://www.acec.org)

American Society of Civil Engineers  
1801 Alexander Bell Drive, Reston, VA 20191-4400  
(800) 548-2723  
[www.asce.org](http://www.asce.org)

Associated General Contractors of America  
2300 Wilson Boulevard, Suite 400, Arlington, VA 22201-3308  
(703) 548-3118  
[www.agc.org](http://www.agc.org)

The copyright for this EJCDC document is owned jointly by the four EJCDC sponsoring organizations and held in trust for their benefit by NSPE.

**STANDARD GENERAL CONDITIONS OF THE  
CONSTRUCTION CONTRACT**

**TABLE OF CONTENTS**

	<b>Page</b>
Article 1 – Definitions and Terminology .....	1
1.01 Defined Terms.....	1
1.02 Terminology .....	5
Article 2 – Preliminary Matters .....	6
2.01 Delivery of Bonds and Evidence of Insurance .....	6
2.02 Copies of Documents .....	6
2.03 Commencement of Contract Times; Notice to Proceed.....	6
2.04 Starting the Work .....	7
2.05 Before Starting Construction .....	7
2.06 Preconstruction Conference; Designation of Authorized Representatives.....	7
2.07 Initial Acceptance of Schedules.....	7
Article 3 – Contract Documents: Intent, Amending, Reuse .....	8
3.01 Intent.....	8
3.02 Reference Standards.....	8
3.03 Reporting and Resolving Discrepancies .....	9
3.04 Amending and Supplementing Contract Documents.....	9
3.05 Reuse of Documents .....	10
3.06 Electronic Data.....	10
Article 4 – Availability of Lands; Subsurface and Physical Conditions; Hazardous Environmental Conditions; Reference Points.....	11
4.01 Availability of Lands.....	11
4.02 Subsurface and Physical Conditions.....	11
4.03 Differing Subsurface or Physical Conditions .....	12
4.04 Underground Facilities.....	13
4.05 Reference Points.....	14
4.06 Hazardous Environmental Condition at Site .....	14
Article 5 – Bonds and Insurance.....	16
5.01 Performance, Payment, and Other Bonds.....	16
5.02 Licensed Sureties and Insurers.....	16
5.03 Certificates of Insurance .....	17
5.04 Contractor’s Insurance .....	17
5.05 Owner’s Liability Insurance.....	19
5.06 Property Insurance.....	19
5.07 Waiver of Rights .....	20
5.08 Receipt and Application of Insurance Proceeds .....	21

5.09	Acceptance of Bonds and Insurance; Option to Replace .....	21
5.10	Partial Utilization, Acknowledgment of Property Insurer.....	22
Article 6 – Contractor’s Responsibilities .....		22
6.01	Supervision and Superintendence.....	22
6.02	Labor; Working Hours .....	22
6.03	Services, Materials, and Equipment .....	22
6.04	Progress Schedule .....	23
6.05	Substitutes and “Or-Equals” .....	23
6.06	Concerning Subcontractors, Suppliers, and Others.....	25
6.07	Patent Fees and Royalties .....	27
6.08	Permits.....	27
6.09	Laws and Regulations .....	28
6.10	Taxes .....	28
6.11	Use of Site and Other Areas.....	28
6.12	Record Documents.....	29
6.13	Safety and Protection .....	29
6.14	Safety Representative.....	30
6.15	Hazard Communication Programs.....	30
6.16	Emergencies .....	30
6.17	Shop Drawings and Samples .....	31
6.18	Continuing the Work.....	32
6.19	Contractor’s General Warranty and Guarantee .....	33
6.20	Indemnification .....	33
6.21	Delegation of Professional Design Services.....	34
Article 7 – Other Work at the Site.....		35
7.01	Related Work at Site .....	35
7.02	Coordination.....	35
7.03	Legal Relationships.....	36
Article 8 – Owner’s Responsibilities.....		36
8.01	Communications to Contractor.....	36
8.02	Replacement of Engineer .....	36
8.03	Furnish Data .....	36
8.04	Pay When Due.....	36
8.05	Lands and Easements; Reports and Tests.....	36
8.06	Insurance.....	36
8.07	Change Orders.....	37
8.08	Inspections, Tests, and Approvals .....	37
8.09	Limitations on Owner’s Responsibilities .....	37
8.10	Undisclosed Hazardous Environmental Condition .....	37
8.11	Evidence of Financial Arrangements.....	37
8.12	Compliance with Safety Program.....	37
Article 9 – Engineer’s Status During Construction.....		37
9.01	Owner’s Representative .....	37

9.02	Visits to Site .....	37
9.03	Project Representative.....	38
9.04	Authorized Variations in Work .....	38
9.05	Rejecting Defective Work.....	38
9.06	Shop Drawings, Change Orders and Payments.....	39
9.07	Determinations for Unit Price Work .....	39
9.08	Decisions on Requirements of Contract Documents and Acceptability of Work.....	39
9.09	Limitations on Engineer’s Authority and Responsibilities .....	39
9.10	Compliance with Safety Program .....	40
Article 10 – Changes in the Work; Claims .....		40
10.01	Authorized Changes in the Work .....	40
10.02	Unauthorized Changes in the Work.....	41
10.03	Execution of Change Orders.....	41
10.04	Notification to Surety.....	41
10.05	Claims.....	41
Article 11 – Cost of the Work; Allowances; Unit Price Work.....		42
11.01	Cost of the Work.....	42
11.02	Allowances .....	45
11.03	Unit Price Work .....	45
Article 12 – Change of Contract Price; Change of Contract Times .....		46
12.01	Change of Contract Price .....	46
12.02	Change of Contract Times .....	47
12.03	Delays .....	47
Article 13 – Tests and Inspections; Correction, Removal or Acceptance of Defective Work.....		48
13.01	Notice of Defects.....	48
13.02	Access to Work .....	48
13.03	Tests and Inspections .....	49
13.04	Uncovering Work.....	49
13.05	Owner May Stop the Work.....	50
13.06	Correction or Removal of Defective Work .....	50
13.07	Correction Period .....	50
13.08	Acceptance of Defective Work.....	51
13.09	Owner May Correct Defective Work .....	52
Article 14 – Payments to Contractor and Completion .....		52
14.01	Schedule of Values.....	52
14.02	Progress Payments .....	52
14.03	Contractor’s Warranty of Title.....	55
14.04	Substantial Completion.....	55
14.05	Partial Utilization .....	56
14.06	Final Inspection .....	57
14.07	Final Payment.....	57
14.08	Final Completion Delayed .....	58

14.09 Waiver of Claims .....	58
Article 15 – Suspension of Work and Termination .....	59
15.01 Owner May Suspend Work.....	59
15.02 Owner May Terminate for Cause .....	59
15.03 Owner May Terminate For Convenience .....	60
15.04 Contractor May Stop Work or Terminate.....	60
Article 16 – Dispute Resolution .....	61
16.01 Methods and Procedures .....	61
Article 17 – Miscellaneous .....	61
17.01 Giving Notice .....	61
17.02 Computation of Times .....	62
17.03 Cumulative Remedies .....	62
17.04 Survival of Obligations .....	62
17.05 Controlling Law .....	62
17.06 Headings .....	62

## ARTICLE 1 – DEFINITIONS AND TERMINOLOGY

### 1.01 *Defined Terms*

- A. Wherever used in the Bidding Requirements or Contract Documents and printed with initial capital letters, the terms listed below will have the meanings indicated which are applicable to both the singular and plural thereof. In addition to terms specifically defined, terms with initial capital letters in the Contract Documents include references to identified articles and paragraphs, and the titles of other documents or forms.
1. *Addenda*—Written or graphic instruments issued prior to the opening of Bids which clarify, correct, or change the Bidding Requirements or the proposed Contract Documents.
  2. *Agreement*—The written instrument which is evidence of the agreement between Owner and Contractor covering the Work.
  3. *Application for Payment*—The form acceptable to Engineer which is to be used by Contractor during the course of the Work in requesting progress or final payments and which is to be accompanied by such supporting documentation as is required by the Contract Documents.
  4. *Asbestos*—Any material that contains more than one percent asbestos and is friable or is releasing asbestos fibers into the air above current action levels established by the United States Occupational Safety and Health Administration.
  5. *Bid*—The offer or proposal of a Bidder submitted on the prescribed form setting forth the prices for the Work to be performed.
  6. *Bidder*—The individual or entity who submits a Bid directly to Owner.
  7. *Bidding Documents*—The Bidding Requirements and the proposed Contract Documents (including all Addenda).
  8. *Bidding Requirements*—The advertisement or invitation to bid, Instructions to Bidders, Bid security of acceptable form, if any, and the Bid Form with any supplements.
  9. *Change Order*—A document recommended by Engineer which is signed by Contractor and Owner and authorizes an addition, deletion, or revision in the Work or an adjustment in the Contract Price or the Contract Times, issued on or after the Effective Date of the Agreement.
  10. *Claim*—A demand or assertion by Owner or Contractor seeking an adjustment of Contract Price or Contract Times, or both, or other relief with respect to the terms of the Contract. A demand for money or services by a third party is not a Claim.
  11. *Contract*—The entire and integrated written agreement between the Owner and Contractor concerning the Work. The Contract supersedes prior negotiations, representations, or agreements, whether written or oral.

12. *Contract Documents*—Those items so designated in the Agreement. Only printed or hard copies of the items listed in the Agreement are Contract Documents. Approved Shop Drawings, other Contractor submittals, and the reports and drawings of subsurface and physical conditions are not Contract Documents.
13. *Contract Price*—The moneys payable by Owner to Contractor for completion of the Work in accordance with the Contract Documents as stated in the Agreement (subject to the provisions of Paragraph 11.03 in the case of Unit Price Work).
14. *Contract Times*—The number of days or the dates stated in the Agreement to: (i) achieve Milestones, if any; (ii) achieve Substantial Completion; and (iii) complete the Work so that it is ready for final payment as evidenced by Engineer's written recommendation of final payment.
15. *Contractor*—The individual or entity with whom Owner has entered into the Agreement.
16. *Cost of the Work*—See Paragraph 11.01 for definition.
17. *Drawings*—That part of the Contract Documents prepared or approved by Engineer which graphically shows the scope, extent, and character of the Work to be performed by Contractor. Shop Drawings and other Contractor submittals are not Drawings as so defined.
18. *Effective Date of the Agreement*—The date indicated in the Agreement on which it becomes effective, but if no such date is indicated, it means the date on which the Agreement is signed and delivered by the last of the two parties to sign and deliver.
19. *Engineer*—The individual or entity named as such in the Agreement.
20. *Field Order*—A written order issued by Engineer which requires minor changes in the Work but which does not involve a change in the Contract Price or the Contract Times.
21. *General Requirements*—Sections of Division 1 of the Specifications.
22. *Hazardous Environmental Condition*—The presence at the Site of Asbestos, PCBs, Petroleum, Hazardous Waste, or Radioactive Material in such quantities or circumstances that may present a substantial danger to persons or property exposed thereto.
23. *Hazardous Waste*—The term Hazardous Waste shall have the meaning provided in Section 1004 of the Solid Waste Disposal Act (42 USC Section 6903) as amended from time to time.
24. *Laws and Regulations; Laws or Regulations*—Any and all applicable laws, rules, regulations, ordinances, codes, and orders of any and all governmental bodies, agencies, authorities, and courts having jurisdiction.
25. *Liens*—Charges, security interests, or encumbrances upon Project funds, real property, or personal property.
26. *Milestone*—A principal event specified in the Contract Documents relating to an intermediate completion date or time prior to Substantial Completion of all the Work.



27. *Notice of Award*—The written notice by Owner to the Successful Bidder stating that upon timely compliance by the Successful Bidder with the conditions precedent listed therein, Owner will sign and deliver the Agreement.
28. *Notice to Proceed*—A written notice given by Owner to Contractor fixing the date on which the Contract Times will commence to run and on which Contractor shall start to perform the Work under the Contract Documents.
29. *Owner*—The individual or entity with whom Contractor has entered into the Agreement and for whom the Work is to be performed.
30. *PCBs*—Polychlorinated biphenyls.
31. *Petroleum*—Petroleum, including crude oil or any fraction thereof which is liquid at standard conditions of temperature and pressure (60 degrees Fahrenheit and 14.7 pounds per square inch absolute), such as oil, petroleum, fuel oil, oil sludge, oil refuse, gasoline, kerosene, and oil mixed with other non-Hazardous Waste and crude oils.
32. *Progress Schedule*—A schedule, prepared and maintained by Contractor, describing the sequence and duration of the activities comprising the Contractor's plan to accomplish the Work within the Contract Times.
33. *Project*—The total construction of which the Work to be performed under the Contract Documents may be the whole, or a part.
34. *Project Manual*—The bound documentary information prepared for bidding and constructing the Work. A listing of the contents of the Project Manual, which may be bound in one or more volumes, is contained in the table(s) of contents.
35. *Radioactive Material*—Source, special nuclear, or byproduct material as defined by the Atomic Energy Act of 1954 (42 USC Section 2011 et seq.) as amended from time to time.
36. *Resident Project Representative*—The authorized representative of Engineer who may be assigned to the Site or any part thereof.
37. *Samples*—Physical examples of materials, equipment, or workmanship that are representative of some portion of the Work and which establish the standards by which such portion of the Work will be judged.
38. *Schedule of Submittals*—A schedule, prepared and maintained by Contractor, of required submittals and the time requirements to support scheduled performance of related construction activities.
39. *Schedule of Values*—A schedule, prepared and maintained by Contractor, allocating portions of the Contract Price to various portions of the Work and used as the basis for reviewing Contractor's Applications for Payment.

40. *Shop Drawings*—All drawings, diagrams, illustrations, schedules, and other data or information which are specifically prepared or assembled by or for Contractor and submitted by Contractor to illustrate some portion of the Work.
41. *Site*—Lands or areas indicated in the Contract Documents as being furnished by Owner upon which the Work is to be performed, including rights-of-way and easements for access thereto, and such other lands furnished by Owner which are designated for the use of Contractor.
42. *Specifications*—That part of the Contract Documents consisting of written requirements for materials, equipment, systems, standards and workmanship as applied to the Work, and certain administrative requirements and procedural matters applicable thereto.
43. *Subcontractor*—An individual or entity having a direct contract with Contractor or with any other Subcontractor for the performance of a part of the Work at the Site.
44. *Substantial Completion*—The time at which the Work (or a specified part thereof) has progressed to the point where, in the opinion of Engineer, the Work (or a specified part thereof) is sufficiently complete, in accordance with the Contract Documents, so that the Work (or a specified part thereof) can be utilized for the purposes for which it is intended. The terms “substantially complete” and “substantially completed” as applied to all or part of the Work refer to Substantial Completion thereof.
45. *Successful Bidder*—The Bidder submitting a responsive Bid to whom Owner makes an award.
46. *Supplementary Conditions*—That part of the Contract Documents which amends or supplements these General Conditions.
47. *Supplier*—A manufacturer, fabricator, supplier, distributor, materialman, or vendor having a direct contract with Contractor or with any Subcontractor to furnish materials or equipment to be incorporated in the Work by Contractor or Subcontractor.
48. *Underground Facilities*—All underground pipelines, conduits, ducts, cables, wires, manholes, vaults, tanks, tunnels, or other such facilities or attachments, and any encasements containing such facilities, including those that convey electricity, gases, steam, liquid petroleum products, telephone or other communications, cable television, water, wastewater, storm water, other liquids or chemicals, or traffic or other control systems.
49. *Unit Price Work*—Work to be paid for on the basis of unit prices.
50. *Work*—The entire construction or the various separately identifiable parts thereof required to be provided under the Contract Documents. Work includes and is the result of performing or providing all labor, services, and documentation necessary to produce such construction, and furnishing, installing, and incorporating all materials and equipment into such construction, all as required by the Contract Documents.
51. *Work Change Directive*—A written statement to Contractor issued on or after the Effective Date of the Agreement and signed by Owner and recommended by Engineer ordering an

addition, deletion, or revision in the Work, or responding to differing or unforeseen subsurface or physical conditions under which the Work is to be performed or to emergencies. A Work Change Directive will not change the Contract Price or the Contract Times but is evidence that the parties expect that the change ordered or documented by a Work Change Directive will be incorporated in a subsequently issued Change Order following negotiations by the parties as to its effect, if any, on the Contract Price or Contract Times.

## 1.02 *Terminology*

A. The words and terms discussed in Paragraph 1.02.B through F are not defined but, when used in the Bidding Requirements or Contract Documents, have the indicated meaning.

### B. *Intent of Certain Terms or Adjectives:*

1. The Contract Documents include the terms “as allowed,” “as approved,” “as ordered,” “as directed” or terms of like effect or import to authorize an exercise of professional judgment by Engineer. In addition, the adjectives “reasonable,” “suitable,” “acceptable,” “proper,” “satisfactory,” or adjectives of like effect or import are used to describe an action or determination of Engineer as to the Work. It is intended that such exercise of professional judgment, action, or determination will be solely to evaluate, in general, the Work for compliance with the information in the Contract Documents and with the design concept of the Project as a functioning whole as shown or indicated in the Contract Documents (unless there is a specific statement indicating otherwise). The use of any such term or adjective is not intended to and shall not be effective to assign to Engineer any duty or authority to supervise or direct the performance of the Work, or any duty or authority to undertake responsibility contrary to the provisions of Paragraph 9.09 or any other provision of the Contract Documents.

### C. *Day:*

1. The word “day” means a calendar day of 24 hours measured from midnight to the next midnight.

### D. *Defective:*

1. The word “defective,” when modifying the word “Work,” refers to Work that is unsatisfactory, faulty, or deficient in that it:
  - a. does not conform to the Contract Documents; or
  - b. does not meet the requirements of any applicable inspection, reference standard, test, or approval referred to in the Contract Documents; or
  - c. has been damaged prior to Engineer’s recommendation of final payment (unless responsibility for the protection thereof has been assumed by Owner at Substantial Completion in accordance with Paragraph 14.04 or 14.05).

E. *Furnish, Install, Perform, Provide:*

1. The word “furnish,” when used in connection with services, materials, or equipment, shall mean to supply and deliver said services, materials, or equipment to the Site (or some other specified location) ready for use or installation and in usable or operable condition.
2. The word “install,” when used in connection with services, materials, or equipment, shall mean to put into use or place in final position said services, materials, or equipment complete and ready for intended use.
3. The words “perform” or “provide,” when used in connection with services, materials, or equipment, shall mean to furnish and install said services, materials, or equipment complete and ready for intended use.
4. When “furnish,” “install,” “perform,” or “provide” is not used in connection with services, materials, or equipment in a context clearly requiring an obligation of Contractor, “provide” is implied.

F. Unless stated otherwise in the Contract Documents, words or phrases that have a well-known technical or construction industry or trade meaning are used in the Contract Documents in accordance with such recognized meaning.

## **ARTICLE 2 – PRELIMINARY MATTERS**

### *2.01 Delivery of Bonds and Evidence of Insurance*

- A. When Contractor delivers the executed counterparts of the Agreement to Owner, Contractor shall also deliver to Owner such bonds as Contractor may be required to furnish.
- B. *Evidence of Insurance:* Before any Work at the Site is started, Contractor and Owner shall each deliver to the other, with copies to each additional insured identified in the Supplementary Conditions, certificates of insurance (and other evidence of insurance which either of them or any additional insured may reasonably request) which Contractor and Owner respectively are required to purchase and maintain in accordance with Article 5.

### *2.02 Copies of Documents*

- A. Owner shall furnish to Contractor up to ten printed or hard copies of the Drawings and Project Manual. Additional copies will be furnished upon request at the cost of reproduction.

### *2.03 Commencement of Contract Times; Notice to Proceed*

- A. The Contract Times will commence to run on the thirtieth day after the Effective Date of the Agreement or, if a Notice to Proceed is given, on the day indicated in the Notice to Proceed. A Notice to Proceed may be given at any time within 30 days after the Effective Date of the Agreement. In no event will the Contract Times commence to run later than the sixtieth day after the day of Bid opening or the thirtieth day after the Effective Date of the Agreement, whichever date is earlier.

## 2.04 *Starting the Work*

- A. Contractor shall start to perform the Work on the date when the Contract Times commence to run. No Work shall be done at the Site prior to the date on which the Contract Times commence to run.

## 2.05 *Before Starting Construction*

- A. *Preliminary Schedules:* Within 10 days after the Effective Date of the Agreement (unless otherwise specified in the General Requirements), Contractor shall submit to Engineer for timely review:
  - 1. a preliminary Progress Schedule indicating the times (numbers of days or dates) for starting and completing the various stages of the Work, including any Milestones specified in the Contract Documents;
  - 2. a preliminary Schedule of Submittals; and
  - 3. a preliminary Schedule of Values for all of the Work which includes quantities and prices of items which when added together equal the Contract Price and subdivides the Work into component parts in sufficient detail to serve as the basis for progress payments during performance of the Work. Such prices will include an appropriate amount of overhead and profit applicable to each item of Work.

## 2.06 *Preconstruction Conference; Designation of Authorized Representatives*

- A. Before any Work at the Site is started, a conference attended by Owner, Contractor, Engineer, and others as appropriate will be held to establish a working understanding among the parties as to the Work and to discuss the schedules referred to in Paragraph 2.05.A, procedures for handling Shop Drawings and other submittals, processing Applications for Payment, and maintaining required records.
- B. At this conference Owner and Contractor each shall designate, in writing, a specific individual to act as its authorized representative with respect to the services and responsibilities under the Contract. Such individuals shall have the authority to transmit instructions, receive information, render decisions relative to the Contract, and otherwise act on behalf of each respective party.

## 2.07 *Initial Acceptance of Schedules*

- A. At least 10 days before submission of the first Application for Payment a conference attended by Contractor, Engineer, and others as appropriate will be held to review for acceptability to Engineer as provided below the schedules submitted in accordance with Paragraph 2.05.A. Contractor shall have an additional 10 days to make corrections and adjustments and to complete and resubmit the schedules. No progress payment shall be made to Contractor until acceptable schedules are submitted to Engineer.
  - 1. The Progress Schedule will be acceptable to Engineer if it provides an orderly progression of the Work to completion within the Contract Times. Such acceptance will not impose on

Engineer responsibility for the Progress Schedule, for sequencing, scheduling, or progress of the Work, nor interfere with or relieve Contractor from Contractor's full responsibility therefor.

2. Contractor's Schedule of Submittals will be acceptable to Engineer if it provides a workable arrangement for reviewing and processing the required submittals.
3. Contractor's Schedule of Values will be acceptable to Engineer as to form and substance if it provides a reasonable allocation of the Contract Price to component parts of the Work.

### **ARTICLE 3 – CONTRACT DOCUMENTS: INTENT, AMENDING, REUSE**

#### **3.01 *Intent***

- A. The Contract Documents are complementary; what is required by one is as binding as if required by all.
- B. It is the intent of the Contract Documents to describe a functionally complete project (or part thereof) to be constructed in accordance with the Contract Documents. Any labor, documentation, services, materials, or equipment that reasonably may be inferred from the Contract Documents or from prevailing custom or trade usage as being required to produce the indicated result will be provided whether or not specifically called for, at no additional cost to Owner.
- C. Clarifications and interpretations of the Contract Documents shall be issued by Engineer as provided in Article 9.

#### **3.02 *Reference Standards***

- A. Standards, Specifications, Codes, Laws, and Regulations
  1. Reference to standards, specifications, manuals, or codes of any technical society, organization, or association, or to Laws or Regulations, whether such reference be specific or by implication, shall mean the standard, specification, manual, code, or Laws or Regulations in effect at the time of opening of Bids (or on the Effective Date of the Agreement if there were no Bids), except as may be otherwise specifically stated in the Contract Documents.
  2. No provision of any such standard, specification, manual, or code, or any instruction of a Supplier, shall be effective to change the duties or responsibilities of Owner, Contractor, or Engineer, or any of their subcontractors, consultants, agents, or employees, from those set forth in the Contract Documents. No such provision or instruction shall be effective to assign to Owner, Engineer, or any of their officers, directors, members, partners, employees, agents, consultants, or subcontractors, any duty or authority to supervise or direct the performance of the Work or any duty or authority to undertake responsibility inconsistent with the provisions of the Contract Documents.

### 3.03 *Reporting and Resolving Discrepancies*

#### A. *Reporting Discrepancies:*

1. *Contractor's Review of Contract Documents Before Starting Work:* Before undertaking each part of the Work, Contractor shall carefully study and compare the Contract Documents and check and verify pertinent figures therein and all applicable field measurements. Contractor shall promptly report in writing to Engineer any conflict, error, ambiguity, or discrepancy which Contractor discovers, or has actual knowledge of, and shall obtain a written interpretation or clarification from Engineer before proceeding with any Work affected thereby.
2. *Contractor's Review of Contract Documents During Performance of Work:* If, during the performance of the Work, Contractor discovers any conflict, error, ambiguity, or discrepancy within the Contract Documents, or between the Contract Documents and (a) any applicable Law or Regulation, (b) any standard, specification, manual, or code, or (c) any instruction of any Supplier, then Contractor shall promptly report it to Engineer in writing. Contractor shall not proceed with the Work affected thereby (except in an emergency as required by Paragraph 6.16.A) until an amendment or supplement to the Contract Documents has been issued by one of the methods indicated in Paragraph 3.04.
3. Contractor shall not be liable to Owner or Engineer for failure to report any conflict, error, ambiguity, or discrepancy in the Contract Documents unless Contractor had actual knowledge thereof.

#### B. *Resolving Discrepancies:*

1. Except as may be otherwise specifically stated in the Contract Documents, the provisions of the Contract Documents shall take precedence in resolving any conflict, error, ambiguity, or discrepancy between the provisions of the Contract Documents and:
  - a. the provisions of any standard, specification, manual, or code, or the instruction of any Supplier (whether or not specifically incorporated by reference in the Contract Documents); or
  - b. the provisions of any Laws or Regulations applicable to the performance of the Work (unless such an interpretation of the provisions of the Contract Documents would result in violation of such Law or Regulation).

### 3.04 *Amending and Supplementing Contract Documents*

- A. The Contract Documents may be amended to provide for additions, deletions, and revisions in the Work or to modify the terms and conditions thereof by either a Change Order or a Work Change Directive.
- B. The requirements of the Contract Documents may be supplemented, and minor variations and deviations in the Work may be authorized, by one or more of the following ways:

1. A Field Order;
2. Engineer's approval of a Shop Drawing or Sample (subject to the provisions of Paragraph 6.17.D.3); or
3. Engineer's written interpretation or clarification.

3.05 *Reuse of Documents*

- A. Contractor and any Subcontractor or Supplier shall not:
1. have or acquire any title to or ownership rights in any of the Drawings, Specifications, or other documents (or copies of any thereof) prepared by or bearing the seal of Engineer or its consultants, including electronic media editions; or
  2. reuse any such Drawings, Specifications, other documents, or copies thereof on extensions of the Project or any other project without written consent of Owner and Engineer and specific written verification or adaptation by Engineer.
- B. The prohibitions of this Paragraph 3.05 will survive final payment, or termination of the Contract. Nothing herein shall preclude Contractor from retaining copies of the Contract Documents for record purposes.

3.06 *Electronic Data*

- A. Unless otherwise stated in the Supplementary Conditions, the data furnished by Owner or Engineer to Contractor, or by Contractor to Owner or Engineer, that may be relied upon are limited to the printed copies (also known as hard copies). Files in electronic media format of text, data, graphics, or other types are furnished only for the convenience of the receiving party. Any conclusion or information obtained or derived from such electronic files will be at the user's sole risk. If there is a discrepancy between the electronic files and the hard copies, the hard copies govern.
- B. Because data stored in electronic media format can deteriorate or be modified inadvertently or otherwise without authorization of the data's creator, the party receiving electronic files agrees that it will perform acceptance tests or procedures within 60 days, after which the receiving party shall be deemed to have accepted the data thus transferred. Any errors detected within the 60-day acceptance period will be corrected by the transferring party.
- C. When transferring documents in electronic media format, the transferring party makes no representations as to long term compatibility, usability, or readability of documents resulting from the use of software application packages, operating systems, or computer hardware differing from those used by the data's creator.



## **ARTICLE 4 – AVAILABILITY OF LANDS; SUBSURFACE AND PHYSICAL CONDITIONS; HAZARDOUS ENVIRONMENTAL CONDITIONS; REFERENCE POINTS**

### **4.01 *Availability of Lands***

- A. Owner shall furnish the Site. Owner shall notify Contractor of any encumbrances or restrictions not of general application but specifically related to use of the Site with which Contractor must comply in performing the Work. Owner will obtain in a timely manner and pay for easements for permanent structures or permanent changes in existing facilities. If Contractor and Owner are unable to agree on entitlement to or on the amount or extent, if any, of any adjustment in the Contract Price or Contract Times, or both, as a result of any delay in Owner's furnishing the Site or a part thereof, Contractor may make a Claim therefor as provided in Paragraph 10.05.
- B. Upon reasonable written request, Owner shall furnish Contractor with a current statement of record legal title and legal description of the lands upon which the Work is to be performed and Owner's interest therein as necessary for giving notice of or filing a mechanic's or construction lien against such lands in accordance with applicable Laws and Regulations.
- C. Contractor shall provide for all additional lands and access thereto that may be required for temporary construction facilities or storage of materials and equipment.

### **4.02 *Subsurface and Physical Conditions***

- A. *Reports and Drawings:* The Supplementary Conditions identify:
  - 1. those reports known to Owner of explorations and tests of subsurface conditions at or contiguous to the Site; and
  - 2. those drawings known to Owner of physical conditions relating to existing surface or subsurface structures at the Site (except Underground Facilities).
- B. *Limited Reliance by Contractor on Technical Data Authorized:* Contractor may rely upon the accuracy of the "technical data" contained in such reports and drawings, but such reports and drawings are not Contract Documents. Such "technical data" is identified in the Supplementary Conditions. Except for such reliance on such "technical data," Contractor may not rely upon or make any claim against Owner or Engineer, or any of their officers, directors, members, partners, employees, agents, consultants, or subcontractors with respect to:
  - 1. the completeness of such reports and drawings for Contractor's purposes, including, but not limited to, any aspects of the means, methods, techniques, sequences, and procedures of construction to be employed by Contractor, and safety precautions and programs incident thereto; or
  - 2. other data, interpretations, opinions, and information contained in such reports or shown or indicated in such drawings; or
  - 3. any Contractor interpretation of or conclusion drawn from any "technical data" or any such other data, interpretations, opinions, or information.

#### 4.03 *Differing Subsurface or Physical Conditions*

- A. *Notice:* If Contractor believes that any subsurface or physical condition that is uncovered or revealed either:
1. is of such a nature as to establish that any “technical data” on which Contractor is entitled to rely as provided in Paragraph 4.02 is materially inaccurate; or
  2. is of such a nature as to require a change in the Contract Documents; or
  3. differs materially from that shown or indicated in the Contract Documents; or
  4. is of an unusual nature, and differs materially from conditions ordinarily encountered and generally recognized as inherent in work of the character provided for in the Contract Documents;

then Contractor shall, promptly after becoming aware thereof and before further disturbing the subsurface or physical conditions or performing any Work in connection therewith (except in an emergency as required by Paragraph 6.16.A), notify Owner and Engineer in writing about such condition. Contractor shall not further disturb such condition or perform any Work in connection therewith (except as aforesaid) until receipt of written order to do so.

- B. *Engineer’s Review:* After receipt of written notice as required by Paragraph 4.03.A, Engineer will promptly review the pertinent condition, determine the necessity of Owner’s obtaining additional exploration or tests with respect thereto, and advise Owner in writing (with a copy to Contractor) of Engineer’s findings and conclusions.

C. *Possible Price and Times Adjustments:*

1. The Contract Price or the Contract Times, or both, will be equitably adjusted to the extent that the existence of such differing subsurface or physical condition causes an increase or decrease in Contractor’s cost of, or time required for, performance of the Work; subject, however, to the following:
  - a. such condition must meet any one or more of the categories described in Paragraph 4.03.A; and
  - b. with respect to Work that is paid for on a unit price basis, any adjustment in Contract Price will be subject to the provisions of Paragraphs 9.07 and 11.03.
2. Contractor shall not be entitled to any adjustment in the Contract Price or Contract Times if:
  - a. Contractor knew of the existence of such conditions at the time Contractor made a final commitment to Owner with respect to Contract Price and Contract Times by the submission of a Bid or becoming bound under a negotiated contract; or
  - b. the existence of such condition could reasonably have been discovered or revealed as a result of any examination, investigation, exploration, test, or study of the Site and

contiguous areas required by the Bidding Requirements or Contract Documents to be conducted by or for Contractor prior to Contractor's making such final commitment; or

- c. Contractor failed to give the written notice as required by Paragraph 4.03.A.
3. If Owner and Contractor are unable to agree on entitlement to or on the amount or extent, if any, of any adjustment in the Contract Price or Contract Times, or both, a Claim may be made therefor as provided in Paragraph 10.05. However, neither Owner or Engineer, or any of their officers, directors, members, partners, employees, agents, consultants, or subcontractors shall be liable to Contractor for any claims, costs, losses, or damages (including but not limited to all fees and charges of engineers, architects, attorneys, and other professionals and all court or arbitration or other dispute resolution costs) sustained by Contractor on or in connection with any other project or anticipated project.

#### 4.04 *Underground Facilities*

A. *Shown or Indicated:* The information and data shown or indicated in the Contract Documents with respect to existing Underground Facilities at or contiguous to the Site is based on information and data furnished to Owner or Engineer by the owners of such Underground Facilities, including Owner, or by others. Unless it is otherwise expressly provided in the Supplementary Conditions:

1. Owner and Engineer shall not be responsible for the accuracy or completeness of any such information or data provided by others; and
2. the cost of all of the following will be included in the Contract Price, and Contractor shall have full responsibility for:
  - a. reviewing and checking all such information and data;
  - b. locating all Underground Facilities shown or indicated in the Contract Documents;
  - c. coordination of the Work with the owners of such Underground Facilities, including Owner, during construction; and
  - d. the safety and protection of all such Underground Facilities and repairing any damage thereto resulting from the Work.

B. *Not Shown or Indicated:*

1. If an Underground Facility is uncovered or revealed at or contiguous to the Site which was not shown or indicated, or not shown or indicated with reasonable accuracy in the Contract Documents, Contractor shall, promptly after becoming aware thereof and before further disturbing conditions affected thereby or performing any Work in connection therewith (except in an emergency as required by Paragraph 6.16.A), identify the owner of such Underground Facility and give written notice to that owner and to Owner and Engineer. Engineer will promptly review the Underground Facility and determine the extent, if any, to which a change is required in the Contract Documents to reflect and document the

consequences of the existence or location of the Underground Facility. During such time, Contractor shall be responsible for the safety and protection of such Underground Facility.

2. If Engineer concludes that a change in the Contract Documents is required, a Work Change Directive or a Change Order will be issued to reflect and document such consequences. An equitable adjustment shall be made in the Contract Price or Contract Times, or both, to the extent that they are attributable to the existence or location of any Underground Facility that was not shown or indicated or not shown or indicated with reasonable accuracy in the Contract Documents and that Contractor did not know of and could not reasonably have been expected to be aware of or to have anticipated. If Owner and Contractor are unable to agree on entitlement to or on the amount or extent, if any, of any such adjustment in Contract Price or Contract Times, Owner or Contractor may make a Claim therefor as provided in Paragraph 10.05.

#### 4.05 *Reference Points*

- A. Owner shall provide engineering surveys to establish reference points for construction which in Engineer's judgment are necessary to enable Contractor to proceed with the Work. Contractor shall be responsible for laying out the Work, shall protect and preserve the established reference points and property monuments, and shall make no changes or relocations without the prior written approval of Owner. Contractor shall report to Engineer whenever any reference point or property monument is lost or destroyed or requires relocation because of necessary changes in grades or locations, and shall be responsible for the accurate replacement or relocation of such reference points or property monuments by professionally qualified personnel.

#### 4.06 *Hazardous Environmental Condition at Site*

- A. *Reports and Drawings:* The Supplementary Conditions identify those reports and drawings known to Owner relating to Hazardous Environmental Conditions that have been identified at the Site.
- B. *Limited Reliance by Contractor on Technical Data Authorized:* Contractor may rely upon the accuracy of the "technical data" contained in such reports and drawings, but such reports and drawings are not Contract Documents. Such "technical data" is identified in the Supplementary Conditions. Except for such reliance on such "technical data," Contractor may not rely upon or make any claim against Owner or Engineer, or any of their officers, directors, members, partners, employees, agents, consultants, or subcontractors with respect to:
  1. the completeness of such reports and drawings for Contractor's purposes, including, but not limited to, any aspects of the means, methods, techniques, sequences and procedures of construction to be employed by Contractor and safety precautions and programs incident thereto; or
  2. other data, interpretations, opinions and information contained in such reports or shown or indicated in such drawings; or
  3. any Contractor interpretation of or conclusion drawn from any "technical data" or any such other data, interpretations, opinions or information.

- C. Contractor shall not be responsible for any Hazardous Environmental Condition uncovered or revealed at the Site which was not shown or indicated in Drawings or Specifications or identified in the Contract Documents to be within the scope of the Work. Contractor shall be responsible for a Hazardous Environmental Condition created with any materials brought to the Site by Contractor, Subcontractors, Suppliers, or anyone else for whom Contractor is responsible.
- D. If Contractor encounters a Hazardous Environmental Condition or if Contractor or anyone for whom Contractor is responsible creates a Hazardous Environmental Condition, Contractor shall immediately: (i) secure or otherwise isolate such condition; (ii) stop all Work in connection with such condition and in any area affected thereby (except in an emergency as required by Paragraph 6.16.A); and (iii) notify Owner and Engineer (and promptly thereafter confirm such notice in writing). Owner shall promptly consult with Engineer concerning the necessity for Owner to retain a qualified expert to evaluate such condition or take corrective action, if any. Promptly after consulting with Engineer, Owner shall take such actions as are necessary to permit Owner to timely obtain required permits and provide Contractor the written notice required by Paragraph 4.06.E.
- E. Contractor shall not be required to resume Work in connection with such condition or in any affected area until after Owner has obtained any required permits related thereto and delivered written notice to Contractor: (i) specifying that such condition and any affected area is or has been rendered safe for the resumption of Work; or (ii) specifying any special conditions under which such Work may be resumed safely. If Owner and Contractor cannot agree as to entitlement to or on the amount or extent, if any, of any adjustment in Contract Price or Contract Times, or both, as a result of such Work stoppage or such special conditions under which Work is agreed to be resumed by Contractor, either party may make a Claim therefor as provided in Paragraph 10.05.
- F. If after receipt of such written notice Contractor does not agree to resume such Work based on a reasonable belief it is unsafe, or does not agree to resume such Work under such special conditions, then Owner may order the portion of the Work that is in the area affected by such condition to be deleted from the Work. If Owner and Contractor cannot agree as to entitlement to or on the amount or extent, if any, of an adjustment in Contract Price or Contract Times as a result of deleting such portion of the Work, then either party may make a Claim therefor as provided in Paragraph 10.05. Owner may have such deleted portion of the Work performed by Owner's own forces or others in accordance with Article 7.
- G. To the fullest extent permitted by Laws and Regulations, Owner shall indemnify and hold harmless Contractor, Subcontractors, and Engineer, and the officers, directors, members, partners, employees, agents, consultants, and subcontractors of each and any of them from and against all claims, costs, losses, and damages (including but not limited to all fees and charges of engineers, architects, attorneys, and other professionals and all court or arbitration or other dispute resolution costs) arising out of or relating to a Hazardous Environmental Condition, provided that such Hazardous Environmental Condition: (i) was not shown or indicated in the Drawings or Specifications or identified in the Contract Documents to be included within the scope of the Work, and (ii) was not created by Contractor or by anyone for whom Contractor is responsible. Nothing in this Paragraph 4.06.G shall obligate Owner to indemnify any individual or entity from and against the consequences of that individual's or entity's own negligence.

- H. To the fullest extent permitted by Laws and Regulations, Contractor shall indemnify and hold harmless Owner and Engineer, and the officers, directors, members, partners, employees, agents, consultants, and subcontractors of each and any of them from and against all claims, costs, losses, and damages (including but not limited to all fees and charges of engineers, architects, attorneys, and other professionals and all court or arbitration or other dispute resolution costs) arising out of or relating to a Hazardous Environmental Condition created by Contractor or by anyone for whom Contractor is responsible. Nothing in this Paragraph 4.06.H shall obligate Contractor to indemnify any individual or entity from and against the consequences of that individual's or entity's own negligence.
- I. The provisions of Paragraphs 4.02, 4.03, and 4.04 do not apply to a Hazardous Environmental Condition uncovered or revealed at the Site.

## **ARTICLE 5 – BONDS AND INSURANCE**

### *5.01 Performance, Payment, and Other Bonds*

- A. Contractor shall furnish performance and payment bonds, each in an amount at least equal to the Contract Price as security for the faithful performance and payment of all of Contractor's obligations under the Contract Documents. These bonds shall remain in effect until one year after the date when final payment becomes due or until completion of the correction period specified in Paragraph 13.07, whichever is later, except as provided otherwise by Laws or Regulations or by the Contract Documents. Contractor shall also furnish such other bonds as are required by the Contract Documents.
- B. All bonds shall be in the form prescribed by the Contract Documents except as provided otherwise by Laws or Regulations, and shall be executed by such sureties as are named in the list of "Companies Holding Certificates of Authority as Acceptable Sureties on Federal Bonds and as Acceptable Reinsuring Companies" as published in Circular 570 (amended) by the Financial Management Service, Surety Bond Branch, U.S. Department of the Treasury. All bonds signed by an agent or attorney-in-fact must be accompanied by a certified copy of that individual's authority to bind the surety. The evidence of authority shall show that it is effective on the date the agent or attorney-in-fact signed each bond.
- C. If the surety on any bond furnished by Contractor is declared bankrupt or becomes insolvent or its right to do business is terminated in any state where any part of the Project is located or it ceases to meet the requirements of Paragraph 5.01.B, Contractor shall promptly notify Owner and Engineer and shall, within 20 days after the event giving rise to such notification, provide another bond and surety, both of which shall comply with the requirements of Paragraphs 5.01.B and 5.02.

### *5.02 Licensed Sureties and Insurers*

- A. All bonds and insurance required by the Contract Documents to be purchased and maintained by Owner or Contractor shall be obtained from surety or insurance companies that are duly licensed or authorized in the jurisdiction in which the Project is located to issue bonds or insurance policies for the limits and coverages so required. Such surety and insurance companies shall also

meet such additional requirements and qualifications as may be provided in the Supplementary Conditions.

### 5.03 *Certificates of Insurance*

- A. Contractor shall deliver to Owner, with copies to each additional insured and loss payee identified in the Supplementary Conditions, certificates of insurance (and other evidence of insurance requested by Owner or any other additional insured) which Contractor is required to purchase and maintain.
- B. Owner shall deliver to Contractor, with copies to each additional insured and loss payee identified in the Supplementary Conditions, certificates of insurance (and other evidence of insurance requested by Contractor or any other additional insured) which Owner is required to purchase and maintain.
- C. Failure of Owner to demand such certificates or other evidence of Contractor's full compliance with these insurance requirements or failure of Owner to identify a deficiency in compliance from the evidence provided shall not be construed as a waiver of Contractor's obligation to maintain such insurance.
- D. Owner does not represent that insurance coverage and limits established in this Contract necessarily will be adequate to protect Contractor.
- E. The insurance and insurance limits required herein shall not be deemed as a limitation on Contractor's liability under the indemnities granted to Owner in the Contract Documents.

### 5.04 *Contractor's Insurance*

- A. Contractor shall purchase and maintain such insurance as is appropriate for the Work being performed and as will provide protection from claims set forth below which may arise out of or result from Contractor's performance of the Work and Contractor's other obligations under the Contract Documents, whether it is to be performed by Contractor, any Subcontractor or Supplier, or by anyone directly or indirectly employed by any of them to perform any of the Work, or by anyone for whose acts any of them may be liable:
  - 1. claims under workers' compensation, disability benefits, and other similar employee benefit acts;
  - 2. claims for damages because of bodily injury, occupational sickness or disease, or death of Contractor's employees;
  - 3. claims for damages because of bodily injury, sickness or disease, or death of any person other than Contractor's employees;
  - 4. claims for damages insured by reasonably available personal injury liability coverage which are sustained:

- a. by any person as a result of an offense directly or indirectly related to the employment of such person by Contractor, or
  - b. by any other person for any other reason;
5. claims for damages, other than to the Work itself, because of injury to or destruction of tangible property wherever located, including loss of use resulting therefrom; and
  6. claims for damages because of bodily injury or death of any person or property damage arising out of the ownership, maintenance or use of any motor vehicle.
- B. The policies of insurance required by this Paragraph 5.04 shall:
1. with respect to insurance required by Paragraphs 5.04.A.3 through 5.04.A.6 inclusive, be written on an occurrence basis, include as additional insureds (subject to any customary exclusion regarding professional liability) Owner and Engineer, and any other individuals or entities identified in the Supplementary Conditions, all of whom shall be listed as additional insureds, and include coverage for the respective officers, directors, members, partners, employees, agents, consultants, and subcontractors of each and any of all such additional insureds, and the insurance afforded to these additional insureds shall provide primary coverage for all claims covered thereby;
  2. include at least the specific coverages and be written for not less than the limits of liability provided in the Supplementary Conditions or required by Laws or Regulations, whichever is greater;
  3. include contractual liability insurance covering Contractor's indemnity obligations under Paragraphs 6.11 and 6.20;
  4. contain a provision or endorsement that the coverage afforded will not be canceled, materially changed or renewal refused until at least 30 days prior written notice has been given to Owner and Contractor and to each other additional insured identified in the Supplementary Conditions to whom a certificate of insurance has been issued (and the certificates of insurance furnished by the Contractor pursuant to Paragraph 5.03 will so provide);
  5. remain in effect at least until final payment and at all times thereafter when Contractor may be correcting, removing, or replacing defective Work in accordance with Paragraph 13.07; and
  6. include completed operations coverage:
    - a. Such insurance shall remain in effect for two years after final payment.
    - b. Contractor shall furnish Owner and each other additional insured identified in the Supplementary Conditions, to whom a certificate of insurance has been issued, evidence satisfactory to Owner and any such additional insured of continuation of such insurance at final payment and one year thereafter.



## 5.05 *Owner's Liability Insurance*

- A. In addition to the insurance required to be provided by Contractor under Paragraph 5.04, Owner, at Owner's option, may purchase and maintain at Owner's expense Owner's own liability insurance as will protect Owner against claims which may arise from operations under the Contract Documents.

## 5.06 *Property Insurance*

- A. Unless otherwise provided in the Supplementary Conditions, Owner shall purchase and maintain property insurance upon the Work at the Site in the amount of the full replacement cost thereof (subject to such deductible amounts as may be provided in the Supplementary Conditions or required by Laws and Regulations). This insurance shall:
1. include the interests of Owner, Contractor, Subcontractors, and Engineer, and any other individuals or entities identified in the Supplementary Conditions, and the officers, directors, members, partners, employees, agents, consultants, and subcontractors of each and any of them, each of whom is deemed to have an insurable interest and shall be listed as a loss payee;
  2. be written on a Builder's Risk "all-risk" policy form that shall at least include insurance for physical loss or damage to the Work, temporary buildings, falsework, and materials and equipment in transit, and shall insure against at least the following perils or causes of loss: fire, lightning, extended coverage, theft, vandalism and malicious mischief, earthquake, collapse, debris removal, demolition occasioned by enforcement of Laws and Regulations, water damage (other than that caused by flood), and such other perils or causes of loss as may be specifically required by the Supplementary Conditions.
  3. include expenses incurred in the repair or replacement of any insured property (including but not limited to fees and charges of engineers and architects);
  4. cover materials and equipment stored at the Site or at another location that was agreed to in writing by Owner prior to being incorporated in the Work, provided that such materials and equipment have been included in an Application for Payment recommended by Engineer;
  5. allow for partial utilization of the Work by Owner;
  6. include testing and startup; and
  7. be maintained in effect until final payment is made unless otherwise agreed to in writing by Owner, Contractor, and Engineer with 30 days written notice to each other loss payee to whom a certificate of insurance has been issued.
- B. Owner shall purchase and maintain such equipment breakdown insurance or additional property insurance as may be required by the Supplementary Conditions or Laws and Regulations which will include the interests of Owner, Contractor, Subcontractors, and Engineer, and any other individuals or entities identified in the Supplementary Conditions, and the officers, directors,

members, partners, employees, agents, consultants and subcontractors of each and any of them, each of whom is deemed to have an insurable interest and shall be listed as a loss payee.

- C. All the policies of insurance (and the certificates or other evidence thereof) required to be purchased and maintained in accordance with this Paragraph 5.06 will contain a provision or endorsement that the coverage afforded will not be canceled or materially changed or renewal refused until at least 30 days prior written notice has been given to Owner and Contractor and to each other loss payee to whom a certificate of insurance has been issued and will contain waiver provisions in accordance with Paragraph 5.07.
- D. Owner shall not be responsible for purchasing and maintaining any property insurance specified in this Paragraph 5.06 to protect the interests of Contractor, Subcontractors, or others in the Work to the extent of any deductible amounts that are identified in the Supplementary Conditions. The risk of loss within such identified deductible amount will be borne by Contractor, Subcontractors, or others suffering any such loss, and if any of them wishes property insurance coverage within the limits of such amounts, each may purchase and maintain it at the purchaser's own expense.
- E. If Contractor requests in writing that other special insurance be included in the property insurance policies provided under this Paragraph 5.06, Owner shall, if possible, include such insurance, and the cost thereof will be charged to Contractor by appropriate Change Order. Prior to commencement of the Work at the Site, Owner shall in writing advise Contractor whether or not such other insurance has been procured by Owner.

#### 5.07 *Waiver of Rights*

- A. Owner and Contractor intend that all policies purchased in accordance with Paragraph 5.06 will protect Owner, Contractor, Subcontractors, and Engineer, and all other individuals or entities identified in the Supplementary Conditions as loss payees (and the officers, directors, members, partners, employees, agents, consultants, and subcontractors of each and any of them) in such policies and will provide primary coverage for all losses and damages caused by the perils or causes of loss covered thereby. All such policies shall contain provisions to the effect that in the event of payment of any loss or damage the insurers will have no rights of recovery against any of the insureds or loss payees thereunder. Owner and Contractor waive all rights against each other and their respective officers, directors, members, partners, employees, agents, consultants and subcontractors of each and any of them for all losses and damages caused by, arising out of or resulting from any of the perils or causes of loss covered by such policies and any other property insurance applicable to the Work; and, in addition, waive all such rights against Subcontractors and Engineer, and all other individuals or entities identified in the Supplementary Conditions as loss payees (and the officers, directors, members, partners, employees, agents, consultants, and subcontractors of each and any of them) under such policies for losses and damages so caused. None of the above waivers shall extend to the rights that any party making such waiver may have to the proceeds of insurance held by Owner as trustee or otherwise payable under any policy so issued.
- B. Owner waives all rights against Contractor, Subcontractors, and Engineer, and the officers, directors, members, partners, employees, agents, consultants and subcontractors of each and any of them for:

1. loss due to business interruption, loss of use, or other consequential loss extending beyond direct physical loss or damage to Owner's property or the Work caused by, arising out of, or resulting from fire or other perils whether or not insured by Owner; and
  2. loss or damage to the completed Project or part thereof caused by, arising out of, or resulting from fire or other insured peril or cause of loss covered by any property insurance maintained on the completed Project or part thereof by Owner during partial utilization pursuant to Paragraph 14.05, after Substantial Completion pursuant to Paragraph 14.04, or after final payment pursuant to Paragraph 14.07.
- C. Any insurance policy maintained by Owner covering any loss, damage or consequential loss referred to in Paragraph 5.07.B shall contain provisions to the effect that in the event of payment of any such loss, damage, or consequential loss, the insurers will have no rights of recovery against Contractor, Subcontractors, or Engineer, and the officers, directors, members, partners, employees, agents, consultants and subcontractors of each and any of them.

#### 5.08 *Receipt and Application of Insurance Proceeds*

- A. Any insured loss under the policies of insurance required by Paragraph 5.06 will be adjusted with Owner and made payable to Owner as fiduciary for the loss payees, as their interests may appear, subject to the requirements of any applicable mortgage clause and of Paragraph 5.08.B. Owner shall deposit in a separate account any money so received and shall distribute it in accordance with such agreement as the parties in interest may reach. If no other special agreement is reached, the damaged Work shall be repaired or replaced, the moneys so received applied on account thereof, and the Work and the cost thereof covered by an appropriate Change Order.
- B. Owner as fiduciary shall have power to adjust and settle any loss with the insurers unless one of the parties in interest shall object in writing within 15 days after the occurrence of loss to Owner's exercise of this power. If such objection be made, Owner as fiduciary shall make settlement with the insurers in accordance with such agreement as the parties in interest may reach. If no such agreement among the parties in interest is reached, Owner as fiduciary shall adjust and settle the loss with the insurers and, if required in writing by any party in interest, Owner as fiduciary shall give bond for the proper performance of such duties.

#### 5.09 *Acceptance of Bonds and Insurance; Option to Replace*

- A. If either Owner or Contractor has any objection to the coverage afforded by or other provisions of the bonds or insurance required to be purchased and maintained by the other party in accordance with Article 5 on the basis of non-conformance with the Contract Documents, the objecting party shall so notify the other party in writing within 10 days after receipt of the certificates (or other evidence requested) required by Paragraph 2.01.B. Owner and Contractor shall each provide to the other such additional information in respect of insurance provided as the other may reasonably request. If either party does not purchase or maintain all of the bonds and insurance required of such party by the Contract Documents, such party shall notify the other party in writing of such failure to purchase prior to the start of the Work, or of such failure to maintain prior to any change in the required coverage. Without prejudice to any other right or remedy, the other party may elect to obtain equivalent bonds or insurance to protect such other party's

interests at the expense of the party who was required to provide such coverage, and a Change Order shall be issued to adjust the Contract Price accordingly.

5.10 *Partial Utilization, Acknowledgment of Property Insurer*

- A. If Owner finds it necessary to occupy or use a portion or portions of the Work prior to Substantial Completion of all the Work as provided in Paragraph 14.05, no such use or occupancy shall commence before the insurers providing the property insurance pursuant to Paragraph 5.06 have acknowledged notice thereof and in writing effected any changes in coverage necessitated thereby. The insurers providing the property insurance shall consent by endorsement on the policy or policies, but the property insurance shall not be canceled or permitted to lapse on account of any such partial use or occupancy.

**ARTICLE 6 – CONTRACTOR’S RESPONSIBILITIES**

6.01 *Supervision and Superintendence*

- A. Contractor shall supervise, inspect, and direct the Work competently and efficiently, devoting such attention thereto and applying such skills and expertise as may be necessary to perform the Work in accordance with the Contract Documents. Contractor shall be solely responsible for the means, methods, techniques, sequences, and procedures of construction. Contractor shall not be responsible for the negligence of Owner or Engineer in the design or specification of a specific means, method, technique, sequence, or procedure of construction which is shown or indicated in and expressly required by the Contract Documents.
- B. At all times during the progress of the Work, Contractor shall assign a competent resident superintendent who shall not be replaced without written notice to Owner and Engineer except under extraordinary circumstances.

6.02 *Labor; Working Hours*

- A. Contractor shall provide competent, suitably qualified personnel to survey and lay out the Work and perform construction as required by the Contract Documents. Contractor shall at all times maintain good discipline and order at the Site.
- B. Except as otherwise required for the safety or protection of persons or the Work or property at the Site or adjacent thereto, and except as otherwise stated in the Contract Documents, all Work at the Site shall be performed during regular working hours. Contractor will not permit the performance of Work on a Saturday, Sunday, or any legal holiday without Owner’s written consent (which will not be unreasonably withheld) given after prior written notice to Engineer.

6.03 *Services, Materials, and Equipment*

- A. Unless otherwise specified in the Contract Documents, Contractor shall provide and assume full responsibility for all services, materials, equipment, labor, transportation, construction equipment and machinery, tools, appliances, fuel, power, light, heat, telephone, water, sanitary facilities, temporary facilities, and all other facilities and incidentals necessary for the performance, testing, start-up, and completion of the Work.

- B. All materials and equipment incorporated into the Work shall be as specified or, if not specified, shall be of good quality and new, except as otherwise provided in the Contract Documents. All special warranties and guarantees required by the Specifications shall expressly run to the benefit of Owner. If required by Engineer, Contractor shall furnish satisfactory evidence (including reports of required tests) as to the source, kind, and quality of materials and equipment.
- C. All materials and equipment shall be stored, applied, installed, connected, erected, protected, used, cleaned, and conditioned in accordance with instructions of the applicable Supplier, except as otherwise may be provided in the Contract Documents.

#### 6.04 *Progress Schedule*

- A. Contractor shall adhere to the Progress Schedule established in accordance with Paragraph 2.07 as it may be adjusted from time to time as provided below.
  - 1. Contractor shall submit to Engineer for acceptance (to the extent indicated in Paragraph 2.07) proposed adjustments in the Progress Schedule that will not result in changing the Contract Times. Such adjustments will comply with any provisions of the General Requirements applicable thereto.
  - 2. Proposed adjustments in the Progress Schedule that will change the Contract Times shall be submitted in accordance with the requirements of Article 12. Adjustments in Contract Times may only be made by a Change Order.

#### 6.05 *Substitutes and "Or-Equals"*

- A. Whenever an item of material or equipment is specified or described in the Contract Documents by using the name of a proprietary item or the name of a particular Supplier, the specification or description is intended to establish the type, function, appearance, and quality required. Unless the specification or description contains or is followed by words reading that no like, equivalent, or "or-equal" item or no substitution is permitted, other items of material or equipment or material or equipment of other Suppliers may be submitted to Engineer for review under the circumstances described below.
  - 1. "*Or-Equal*" Items: If in Engineer's sole discretion an item of material or equipment proposed by Contractor is functionally equal to that named and sufficiently similar so that no change in related Work will be required, it may be considered by Engineer as an "or-equal" item, in which case review and approval of the proposed item may, in Engineer's sole discretion, be accomplished without compliance with some or all of the requirements for approval of proposed substitute items. For the purposes of this Paragraph 6.05.A.1, a proposed item of material or equipment will be considered functionally equal to an item so named if:
    - a. in the exercise of reasonable judgment Engineer determines that:
      - 1) it is at least equal in materials of construction, quality, durability, appearance, strength, and design characteristics;

- 2) it will reliably perform at least equally well the function and achieve the results imposed by the design concept of the completed Project as a functioning whole; and
  - 3) it has a proven record of performance and availability of responsive service.
- b. Contractor certifies that, if approved and incorporated into the Work:
- 1) there will be no increase in cost to the Owner or increase in Contract Times; and
  - 2) it will conform substantially to the detailed requirements of the item named in the Contract Documents.

2. *Substitute Items:*

- a. If in Engineer's sole discretion an item of material or equipment proposed by Contractor does not qualify as an "or-equal" item under Paragraph 6.05.A.1, it will be considered a proposed substitute item.
- b. Contractor shall submit sufficient information as provided below to allow Engineer to determine if the item of material or equipment proposed is essentially equivalent to that named and an acceptable substitute therefor. Requests for review of proposed substitute items of material or equipment will not be accepted by Engineer from anyone other than Contractor.
- c. The requirements for review by Engineer will be as set forth in Paragraph 6.05.A.2.d, as supplemented by the General Requirements, and as Engineer may decide is appropriate under the circumstances.
- d. Contractor shall make written application to Engineer for review of a proposed substitute item of material or equipment that Contractor seeks to furnish or use. The application:
  - 1) shall certify that the proposed substitute item will:
    - a) perform adequately the functions and achieve the results called for by the general design,
    - b) be similar in substance to that specified, and
    - c) be suited to the same use as that specified;
  - 2) will state:
    - a) the extent, if any, to which the use of the proposed substitute item will prejudice Contractor's achievement of Substantial Completion on time,
    - b) whether use of the proposed substitute item in the Work will require a change in any of the Contract Documents (or in the provisions of any other direct contract with Owner for other work on the Project) to adapt the design to the proposed substitute item, and

- c) whether incorporation or use of the proposed substitute item in connection with the Work is subject to payment of any license fee or royalty;
  - 3) will identify:
    - a) all variations of the proposed substitute item from that specified, and
    - b) available engineering, sales, maintenance, repair, and replacement services; and
  - 4) shall contain an itemized estimate of all costs or credits that will result directly or indirectly from use of such substitute item, including costs of redesign and claims of other contractors affected by any resulting change.
- B. *Substitute Construction Methods or Procedures:* If a specific means, method, technique, sequence, or procedure of construction is expressly required by the Contract Documents, Contractor may furnish or utilize a substitute means, method, technique, sequence, or procedure of construction approved by Engineer. Contractor shall submit sufficient information to allow Engineer, in Engineer's sole discretion, to determine that the substitute proposed is equivalent to that expressly called for by the Contract Documents. The requirements for review by Engineer will be similar to those provided in Paragraph 6.05.A.2.
- C. *Engineer's Evaluation:* Engineer will be allowed a reasonable time within which to evaluate each proposal or submittal made pursuant to Paragraphs 6.05.A and 6.05.B. Engineer may require Contractor to furnish additional data about the proposed substitute item. Engineer will be the sole judge of acceptability. No "or equal" or substitute will be ordered, installed or utilized until Engineer's review is complete, which will be evidenced by a Change Order in the case of a substitute and an approved Shop Drawing for an "or equal." Engineer will advise Contractor in writing of any negative determination.
- D. *Special Guarantee:* Owner may require Contractor to furnish at Contractor's expense a special performance guarantee or other surety with respect to any substitute.
- E. *Engineer's Cost Reimbursement:* Engineer will record Engineer's costs in evaluating a substitute proposed or submitted by Contractor pursuant to Paragraphs 6.05.A.2 and 6.05.B. Whether or not Engineer approves a substitute so proposed or submitted by Contractor, Contractor shall reimburse Owner for the reasonable charges of Engineer for evaluating each such proposed substitute. Contractor shall also reimburse Owner for the reasonable charges of Engineer for making changes in the Contract Documents (or in the provisions of any other direct contract with Owner) resulting from the acceptance of each proposed substitute.
- F. *Contractor's Expense:* Contractor shall provide all data in support of any proposed substitute or "or-equal" at Contractor's expense.

#### 6.06 *Concerning Subcontractors, Suppliers, and Others*

- A. Contractor shall not employ any Subcontractor, Supplier, or other individual or entity (including those acceptable to Owner as indicated in Paragraph 6.06.B), whether initially or as a replacement, against whom Owner may have reasonable objection. Contractor shall not be

required to employ any Subcontractor, Supplier, or other individual or entity to furnish or perform any of the Work against whom Contractor has reasonable objection.

- B. If the Supplementary Conditions require the identity of certain Subcontractors, Suppliers, or other individuals or entities to be submitted to Owner in advance for acceptance by Owner by a specified date prior to the Effective Date of the Agreement, and if Contractor has submitted a list thereof in accordance with the Supplementary Conditions, Owner's acceptance (either in writing or by failing to make written objection thereto by the date indicated for acceptance or objection in the Bidding Documents or the Contract Documents) of any such Subcontractor, Supplier, or other individual or entity so identified may be revoked on the basis of reasonable objection after due investigation. Contractor shall submit an acceptable replacement for the rejected Subcontractor, Supplier, or other individual or entity, and the Contract Price will be adjusted by the difference in the cost occasioned by such replacement, and an appropriate Change Order will be issued. No acceptance by Owner of any such Subcontractor, Supplier, or other individual or entity, whether initially or as a replacement, shall constitute a waiver of any right of Owner or Engineer to reject defective Work.
- C. Contractor shall be fully responsible to Owner and Engineer for all acts and omissions of the Subcontractors, Suppliers, and other individuals or entities performing or furnishing any of the Work just as Contractor is responsible for Contractor's own acts and omissions. Nothing in the Contract Documents:
1. shall create for the benefit of any such Subcontractor, Supplier, or other individual or entity any contractual relationship between Owner or Engineer and any such Subcontractor, Supplier or other individual or entity; nor
  2. shall create any obligation on the part of Owner or Engineer to pay or to see to the payment of any moneys due any such Subcontractor, Supplier, or other individual or entity except as may otherwise be required by Laws and Regulations.
- D. Contractor shall be solely responsible for scheduling and coordinating the Work of Subcontractors, Suppliers, and other individuals or entities performing or furnishing any of the Work under a direct or indirect contract with Contractor.
- E. Contractor shall require all Subcontractors, Suppliers, and such other individuals or entities performing or furnishing any of the Work to communicate with Engineer through Contractor.
- F. The divisions and sections of the Specifications and the identifications of any Drawings shall not control Contractor in dividing the Work among Subcontractors or Suppliers or delineating the Work to be performed by any specific trade.
- G. All Work performed for Contractor by a Subcontractor or Supplier will be pursuant to an appropriate agreement between Contractor and the Subcontractor or Supplier which specifically binds the Subcontractor or Supplier to the applicable terms and conditions of the Contract Documents for the benefit of Owner and Engineer. Whenever any such agreement is with a Subcontractor or Supplier who is listed as a loss payee on the property insurance provided in Paragraph 5.06, the agreement between the Contractor and the Subcontractor or Supplier will contain provisions whereby the Subcontractor or Supplier waives all rights against Owner,



Contractor, Engineer, and all other individuals or entities identified in the Supplementary Conditions to be listed as insureds or loss payees (and the officers, directors, members, partners, employees, agents, consultants, and subcontractors of each and any of them) for all losses and damages caused by, arising out of, relating to, or resulting from any of the perils or causes of loss covered by such policies and any other property insurance applicable to the Work. If the insurers on any such policies require separate waiver forms to be signed by any Subcontractor or Supplier, Contractor will obtain the same.

#### 6.07 *Patent Fees and Royalties*

- A. Contractor shall pay all license fees and royalties and assume all costs incident to the use in the performance of the Work or the incorporation in the Work of any invention, design, process, product, or device which is the subject of patent rights or copyrights held by others. If a particular invention, design, process, product, or device is specified in the Contract Documents for use in the performance of the Work and if, to the actual knowledge of Owner or Engineer, its use is subject to patent rights or copyrights calling for the payment of any license fee or royalty to others, the existence of such rights shall be disclosed by Owner in the Contract Documents.
- B. To the fullest extent permitted by Laws and Regulations, Owner shall indemnify and hold harmless Contractor, and its officers, directors, members, partners, employees, agents, consultants, and subcontractors from and against all claims, costs, losses, and damages (including but not limited to all fees and charges of engineers, architects, attorneys, and other professionals, and all court or arbitration or other dispute resolution costs) arising out of or relating to any infringement of patent rights or copyrights incident to the use in the performance of the Work or resulting from the incorporation in the Work of any invention, design, process, product, or device specified in the Contract Documents, but not identified as being subject to payment of any license fee or royalty to others required by patent rights or copyrights.
- C. To the fullest extent permitted by Laws and Regulations, Contractor shall indemnify and hold harmless Owner and Engineer, and the officers, directors, members, partners, employees, agents, consultants and subcontractors of each and any of them from and against all claims, costs, losses, and damages (including but not limited to all fees and charges of engineers, architects, attorneys, and other professionals and all court or arbitration or other dispute resolution costs) arising out of or relating to any infringement of patent rights or copyrights incident to the use in the performance of the Work or resulting from the incorporation in the Work of any invention, design, process, product, or device not specified in the Contract Documents.

#### 6.08 *Permits*

- A. Unless otherwise provided in the Supplementary Conditions, Contractor shall obtain and pay for all construction permits and licenses. Owner shall assist Contractor, when necessary, in obtaining such permits and licenses. Contractor shall pay all governmental charges and inspection fees necessary for the prosecution of the Work which are applicable at the time of opening of Bids, or, if there are no Bids, on the Effective Date of the Agreement. Owner shall pay all charges of utility owners for connections for providing permanent service to the Work.

## 6.09 *Laws and Regulations*

- A. Contractor shall give all notices required by and shall comply with all Laws and Regulations applicable to the performance of the Work. Except where otherwise expressly required by applicable Laws and Regulations, neither Owner nor Engineer shall be responsible for monitoring Contractor's compliance with any Laws or Regulations.
- B. If Contractor performs any Work knowing or having reason to know that it is contrary to Laws or Regulations, Contractor shall bear all claims, costs, losses, and damages (including but not limited to all fees and charges of engineers, architects, attorneys, and other professionals and all court or arbitration or other dispute resolution costs) arising out of or relating to such Work. However, it shall not be Contractor's responsibility to make certain that the Specifications and Drawings are in accordance with Laws and Regulations, but this shall not relieve Contractor of Contractor's obligations under Paragraph 3.03.
- C. Changes in Laws or Regulations not known at the time of opening of Bids (or, on the Effective Date of the Agreement if there were no Bids) having an effect on the cost or time of performance of the Work shall be the subject of an adjustment in Contract Price or Contract Times. If Owner and Contractor are unable to agree on entitlement to or on the amount or extent, if any, of any such adjustment, a Claim may be made therefor as provided in Paragraph 10.05.

## 6.10 *Taxes*

- A. Contractor shall pay all sales, consumer, use, and other similar taxes required to be paid by Contractor in accordance with the Laws and Regulations of the place of the Project which are applicable during the performance of the Work.

## 6.11 *Use of Site and Other Areas*

### A. *Limitation on Use of Site and Other Areas:*

1. Contractor shall confine construction equipment, the storage of materials and equipment, and the operations of workers to the Site and other areas permitted by Laws and Regulations, and shall not unreasonably encumber the Site and other areas with construction equipment or other materials or equipment. Contractor shall assume full responsibility for any damage to any such land or area, or to the owner or occupant thereof, or of any adjacent land or areas resulting from the performance of the Work.
2. Should any claim be made by any such owner or occupant because of the performance of the Work, Contractor shall promptly settle with such other party by negotiation or otherwise resolve the claim by arbitration or other dispute resolution proceeding or at law.
3. To the fullest extent permitted by Laws and Regulations, Contractor shall indemnify and hold harmless Owner and Engineer, and the officers, directors, members, partners, employees, agents, consultants and subcontractors of each and any of them from and against all claims, costs, losses, and damages (including but not limited to all fees and charges of engineers, architects, attorneys, and other professionals and all court or arbitration or other dispute resolution costs) arising out of or relating to any claim or action, legal or equitable, brought

by any such owner or occupant against Owner, Engineer, or any other party indemnified hereunder to the extent caused by or based upon Contractor's performance of the Work.

- B. *Removal of Debris During Performance of the Work:* During the progress of the Work Contractor shall keep the Site and other areas free from accumulations of waste materials, rubbish, and other debris. Removal and disposal of such waste materials, rubbish, and other debris shall conform to applicable Laws and Regulations.
- C. *Cleaning:* Prior to Substantial Completion of the Work Contractor shall clean the Site and the Work and make it ready for utilization by Owner. At the completion of the Work Contractor shall remove from the Site all tools, appliances, construction equipment and machinery, and surplus materials and shall restore to original condition all property not designated for alteration by the Contract Documents.
- D. *Loading Structures:* Contractor shall not load nor permit any part of any structure to be loaded in any manner that will endanger the structure, nor shall Contractor subject any part of the Work or adjacent property to stresses or pressures that will endanger it.

#### 6.12 *Record Documents*

- A. Contractor shall maintain in a safe place at the Site one record copy of all Drawings, Specifications, Addenda, Change Orders, Work Change Directives, Field Orders, and written interpretations and clarifications in good order and annotated to show changes made during construction. These record documents together with all approved Samples and a counterpart of all approved Shop Drawings will be available to Engineer for reference. Upon completion of the Work, these record documents, Samples, and Shop Drawings will be delivered to Engineer for Owner.

#### 6.13 *Safety and Protection*

- A. Contractor shall be solely responsible for initiating, maintaining and supervising all safety precautions and programs in connection with the Work. Such responsibility does not relieve Subcontractors of their responsibility for the safety of persons or property in the performance of their work, nor for compliance with applicable safety Laws and Regulations. Contractor shall take all necessary precautions for the safety of, and shall provide the necessary protection to prevent damage, injury or loss to:
  - 1. all persons on the Site or who may be affected by the Work;
  - 2. all the Work and materials and equipment to be incorporated therein, whether in storage on or off the Site; and
  - 3. other property at the Site or adjacent thereto, including trees, shrubs, lawns, walks, pavements, roadways, structures, utilities, and Underground Facilities not designated for removal, relocation, or replacement in the course of construction.
- B. Contractor shall comply with all applicable Laws and Regulations relating to the safety of persons or property, or to the protection of persons or property from damage, injury, or loss; and

shall erect and maintain all necessary safeguards for such safety and protection. Contractor shall notify owners of adjacent property and of Underground Facilities and other utility owners when prosecution of the Work may affect them, and shall cooperate with them in the protection, removal, relocation, and replacement of their property.

- C. Contractor shall comply with the applicable requirements of Owner's safety programs, if any. The Supplementary Conditions identify any Owner's safety programs that are applicable to the Work.
- D. Contractor shall inform Owner and Engineer of the specific requirements of Contractor's safety program with which Owner's and Engineer's employees and representatives must comply while at the Site.
- E. All damage, injury, or loss to any property referred to in Paragraph 6.13.A.2 or 6.13.A.3 caused, directly or indirectly, in whole or in part, by Contractor, any Subcontractor, Supplier, or any other individual or entity directly or indirectly employed by any of them to perform any of the Work, or anyone for whose acts any of them may be liable, shall be remedied by Contractor (except damage or loss attributable to the fault of Drawings or Specifications or to the acts or omissions of Owner or Engineer or anyone employed by any of them, or anyone for whose acts any of them may be liable, and not attributable, directly or indirectly, in whole or in part, to the fault or negligence of Contractor or any Subcontractor, Supplier, or other individual or entity directly or indirectly employed by any of them).
- F. Contractor's duties and responsibilities for safety and for protection of the Work shall continue until such time as all the Work is completed and Engineer has issued a notice to Owner and Contractor in accordance with Paragraph 14.07.B that the Work is acceptable (except as otherwise expressly provided in connection with Substantial Completion).

#### 6.14 *Safety Representative*

- A. Contractor shall designate a qualified and experienced safety representative at the Site whose duties and responsibilities shall be the prevention of accidents and the maintaining and supervising of safety precautions and programs.

#### 6.15 *Hazard Communication Programs*

- A. Contractor shall be responsible for coordinating any exchange of material safety data sheets or other hazard communication information required to be made available to or exchanged between or among employers at the Site in accordance with Laws or Regulations.

#### 6.16 *Emergencies*

- A. In emergencies affecting the safety or protection of persons or the Work or property at the Site or adjacent thereto, Contractor is obligated to act to prevent threatened damage, injury, or loss. Contractor shall give Engineer prompt written notice if Contractor believes that any significant changes in the Work or variations from the Contract Documents have been caused thereby or are required as a result thereof. If Engineer determines that a change in the Contract Documents is

required because of the action taken by Contractor in response to such an emergency, a Work Change Directive or Change Order will be issued.

#### 6.17 *Shop Drawings and Samples*

A. Contractor shall submit Shop Drawings and Samples to Engineer for review and approval in accordance with the accepted Schedule of Submittals (as required by Paragraph 2.07). Each submittal will be identified as Engineer may require.

##### 1. *Shop Drawings:*

- a. Submit number of copies specified in the General Requirements.
- b. Data shown on the Shop Drawings will be complete with respect to quantities, dimensions, specified performance and design criteria, materials, and similar data to show Engineer the services, materials, and equipment Contractor proposes to provide and to enable Engineer to review the information for the limited purposes required by Paragraph 6.17.D.

##### 2. *Samples:*

- a. Submit number of Samples specified in the Specifications.
- b. Clearly identify each Sample as to material, Supplier, pertinent data such as catalog numbers, the use for which intended and other data as Engineer may require to enable Engineer to review the submittal for the limited purposes required by Paragraph 6.17.D.

B. Where a Shop Drawing or Sample is required by the Contract Documents or the Schedule of Submittals, any related Work performed prior to Engineer's review and approval of the pertinent submittal will be at the sole expense and responsibility of Contractor.

#### C. *Submittal Procedures:*

##### 1. Before submitting each Shop Drawing or Sample, Contractor shall have:

- a. reviewed and coordinated each Shop Drawing or Sample with other Shop Drawings and Samples and with the requirements of the Work and the Contract Documents;
- b. determined and verified all field measurements, quantities, dimensions, specified performance and design criteria, installation requirements, materials, catalog numbers, and similar information with respect thereto;
- c. determined and verified the suitability of all materials offered with respect to the indicated application, fabrication, shipping, handling, storage, assembly, and installation pertaining to the performance of the Work; and
- d. determined and verified all information relative to Contractor's responsibilities for means, methods, techniques, sequences, and procedures of construction, and safety precautions and programs incident thereto.

2. Each submittal shall bear a stamp or specific written certification that Contractor has satisfied Contractor's obligations under the Contract Documents with respect to Contractor's review and approval of that submittal.
3. With each submittal, Contractor shall give Engineer specific written notice of any variations that the Shop Drawing or Sample may have from the requirements of the Contract Documents. This notice shall be both a written communication separate from the Shop Drawings or Sample submittal; and, in addition, by a specific notation made on each Shop Drawing or Sample submitted to Engineer for review and approval of each such variation.

D. *Engineer's Review:*

1. Engineer will provide timely review of Shop Drawings and Samples in accordance with the Schedule of Submittals acceptable to Engineer. Engineer's review and approval will be only to determine if the items covered by the submittals will, after installation or incorporation in the Work, conform to the information given in the Contract Documents and be compatible with the design concept of the completed Project as a functioning whole as indicated by the Contract Documents.
2. Engineer's review and approval will not extend to means, methods, techniques, sequences, or procedures of construction (except where a particular means, method, technique, sequence, or procedure of construction is specifically and expressly called for by the Contract Documents) or to safety precautions or programs incident thereto. The review and approval of a separate item as such will not indicate approval of the assembly in which the item functions.
3. Engineer's review and approval shall not relieve Contractor from responsibility for any variation from the requirements of the Contract Documents unless Contractor has complied with the requirements of Paragraph 6.17.C.3 and Engineer has given written approval of each such variation by specific written notation thereof incorporated in or accompanying the Shop Drawing or Sample. Engineer's review and approval shall not relieve Contractor from responsibility for complying with the requirements of Paragraph 6.17.C.1.

E. *Resubmittal Procedures:*

1. Contractor shall make corrections required by Engineer and shall return the required number of corrected copies of Shop Drawings and submit, as required, new Samples for review and approval. Contractor shall direct specific attention in writing to revisions other than the corrections called for by Engineer on previous submittals.

6.18 *Continuing the Work*

- A. Contractor shall carry on the Work and adhere to the Progress Schedule during all disputes or disagreements with Owner. No Work shall be delayed or postponed pending resolution of any disputes or disagreements, except as permitted by Paragraph 15.04 or as Owner and Contractor may otherwise agree in writing.

## 6.19 *Contractor's General Warranty and Guarantee*

- A. Contractor warrants and guarantees to Owner that all Work will be in accordance with the Contract Documents and will not be defective. Engineer and its officers, directors, members, partners, employees, agents, consultants, and subcontractors shall be entitled to rely on representation of Contractor's warranty and guarantee.
- B. Contractor's warranty and guarantee hereunder excludes defects or damage caused by:
  - 1. abuse, modification, or improper maintenance or operation by persons other than Contractor, Subcontractors, Suppliers, or any other individual or entity for whom Contractor is responsible; or
  - 2. normal wear and tear under normal usage.
- C. Contractor's obligation to perform and complete the Work in accordance with the Contract Documents shall be absolute. None of the following will constitute an acceptance of Work that is not in accordance with the Contract Documents or a release of Contractor's obligation to perform the Work in accordance with the Contract Documents:
  - 1. observations by Engineer;
  - 2. recommendation by Engineer or payment by Owner of any progress or final payment;
  - 3. the issuance of a certificate of Substantial Completion by Engineer or any payment related thereto by Owner;
  - 4. use or occupancy of the Work or any part thereof by Owner;
  - 5. any review and approval of a Shop Drawing or Sample submittal or the issuance of a notice of acceptability by Engineer;
  - 6. any inspection, test, or approval by others; or
  - 7. any correction of defective Work by Owner.

## 6.20 *Indemnification*

- A. To the fullest extent permitted by Laws and Regulations, Contractor shall indemnify and hold harmless Owner and Engineer, and the officers, directors, members, partners, employees, agents, consultants and subcontractors of each and any of them from and against all claims, costs, losses, and damages (including but not limited to all fees and charges of engineers, architects, attorneys, and other professionals and all court or arbitration or other dispute resolution costs) arising out of or relating to the performance of the Work, provided that any such claim, cost, loss, or damage is attributable to bodily injury, sickness, disease, or death, or to injury to or destruction of tangible property (other than the Work itself), including the loss of use resulting therefrom but only to the extent caused by any negligent act or omission of Contractor, any Subcontractor, any Supplier, or any individual or entity directly or indirectly employed by any of them to perform any of the Work or anyone for whose acts any of them may be liable .

- B. In any and all claims against Owner or Engineer or any of their officers, directors, members, partners, employees, agents, consultants, or subcontractors by any employee (or the survivor or personal representative of such employee) of Contractor, any Subcontractor, any Supplier, or any individual or entity directly or indirectly employed by any of them to perform any of the Work, or anyone for whose acts any of them may be liable, the indemnification obligation under Paragraph 6.20.A shall not be limited in any way by any limitation on the amount or type of damages, compensation, or benefits payable by or for Contractor or any such Subcontractor, Supplier, or other individual or entity under workers' compensation acts, disability benefit acts, or other employee benefit acts.
- C. The indemnification obligations of Contractor under Paragraph 6.20.A shall not extend to the liability of Engineer and Engineer's officers, directors, members, partners, employees, agents, consultants and subcontractors arising out of:
  - 1. the preparation or approval of, or the failure to prepare or approve maps, Drawings, opinions, reports, surveys, Change Orders, designs, or Specifications; or
  - 2. giving directions or instructions, or failing to give them, if that is the primary cause of the injury or damage.

#### 6.21 *Delegation of Professional Design Services*

- A. Contractor will not be required to provide professional design services unless such services are specifically required by the Contract Documents for a portion of the Work or unless such services are required to carry out Contractor's responsibilities for construction means, methods, techniques, sequences and procedures. Contractor shall not be required to provide professional services in violation of applicable law.
- B. If professional design services or certifications by a design professional related to systems, materials or equipment are specifically required of Contractor by the Contract Documents, Owner and Engineer will specify all performance and design criteria that such services must satisfy. Contractor shall cause such services or certifications to be provided by a properly licensed professional, whose signature and seal shall appear on all drawings, calculations, specifications, certifications, Shop Drawings and other submittals prepared by such professional. Shop Drawings and other submittals related to the Work designed or certified by such professional, if prepared by others, shall bear such professional's written approval when submitted to Engineer.
- C. Owner and Engineer shall be entitled to rely upon the adequacy, accuracy and completeness of the services, certifications or approvals performed by such design professionals, provided Owner and Engineer have specified to Contractor all performance and design criteria that such services must satisfy.
- D. Pursuant to this Paragraph 6.21, Engineer's review and approval of design calculations and design drawings will be only for the limited purpose of checking for conformance with performance and design criteria given and the design concept expressed in the Contract Documents. Engineer's review and approval of Shop Drawings and other submittals (except design calculations and design drawings) will be only for the purpose stated in Paragraph 6.17.D.1.



- E. Contractor shall not be responsible for the adequacy of the performance or design criteria required by the Contract Documents.

## **ARTICLE 7 – OTHER WORK AT THE SITE**

### *7.01 Related Work at Site*

- A. Owner may perform other work related to the Project at the Site with Owner’s employees, or through other direct contracts therefor, or have other work performed by utility owners. If such other work is not noted in the Contract Documents, then:
  - 1. written notice thereof will be given to Contractor prior to starting any such other work; and
  - 2. if Owner and Contractor are unable to agree on entitlement to or on the amount or extent, if any, of any adjustment in the Contract Price or Contract Times that should be allowed as a result of such other work, a Claim may be made therefor as provided in Paragraph 10.05.
- B. Contractor shall afford each other contractor who is a party to such a direct contract, each utility owner, and Owner, if Owner is performing other work with Owner’s employees, proper and safe access to the Site, provide a reasonable opportunity for the introduction and storage of materials and equipment and the execution of such other work, and properly coordinate the Work with theirs. Contractor shall do all cutting, fitting, and patching of the Work that may be required to properly connect or otherwise make its several parts come together and properly integrate with such other work. Contractor shall not endanger any work of others by cutting, excavating, or otherwise altering such work; provided, however, that Contractor may cut or alter others' work with the written consent of Engineer and the others whose work will be affected. The duties and responsibilities of Contractor under this Paragraph are for the benefit of such utility owners and other contractors to the extent that there are comparable provisions for the benefit of Contractor in said direct contracts between Owner and such utility owners and other contractors.
- C. If the proper execution or results of any part of Contractor’s Work depends upon work performed by others under this Article 7, Contractor shall inspect such other work and promptly report to Engineer in writing any delays, defects, or deficiencies in such other work that render it unavailable or unsuitable for the proper execution and results of Contractor’s Work. Contractor’s failure to so report will constitute an acceptance of such other work as fit and proper for integration with Contractor’s Work except for latent defects and deficiencies in such other work.

### *7.02 Coordination*

- A. If Owner intends to contract with others for the performance of other work on the Project at the Site, the following will be set forth in Supplementary Conditions:
  - 1. the individual or entity who will have authority and responsibility for coordination of the activities among the various contractors will be identified;
  - 2. the specific matters to be covered by such authority and responsibility will be itemized; and
  - 3. the extent of such authority and responsibilities will be provided.

- B. Unless otherwise provided in the Supplementary Conditions, Owner shall have sole authority and responsibility for such coordination.

7.03 *Legal Relationships*

- A. Paragraphs 7.01.A and 7.02 are not applicable for utilities not under the control of Owner.
- B. Each other direct contract of Owner under Paragraph 7.01.A shall provide that the other contractor is liable to Owner and Contractor for the reasonable direct delay and disruption costs incurred by Contractor as a result of the other contractor's wrongful actions or inactions.
- C. Contractor shall be liable to Owner and any other contractor under direct contract to Owner for the reasonable direct delay and disruption costs incurred by such other contractor as a result of Contractor's wrongful action or inactions.

**ARTICLE 8 – OWNER'S RESPONSIBILITIES**

8.01 *Communications to Contractor*

- A. Except as otherwise provided in these General Conditions, Owner shall issue all communications to Contractor through Engineer.

8.02 *Replacement of Engineer*

- A. In case of termination of the employment of Engineer, Owner shall appoint an engineer to whom Contractor makes no reasonable objection, whose status under the Contract Documents shall be that of the former Engineer.

8.03 *Furnish Data*

- A. Owner shall promptly furnish the data required of Owner under the Contract Documents.

8.04 *Pay When Due*

- A. Owner shall make payments to Contractor when they are due as provided in Paragraphs 14.02.C and 14.07.C.

8.05 *Lands and Easements; Reports and Tests*

- A. Owner's duties with respect to providing lands and easements and providing engineering surveys to establish reference points are set forth in Paragraphs 4.01 and 4.05. Paragraph 4.02 refers to Owner's identifying and making available to Contractor copies of reports of explorations and tests of subsurface conditions and drawings of physical conditions relating to existing surface or subsurface structures at the Site.

8.06 *Insurance*

- A. Owner's responsibilities, if any, with respect to purchasing and maintaining liability and property insurance are set forth in Article 5.

8.07 *Change Orders*

A. Owner is obligated to execute Change Orders as indicated in Paragraph 10.03.

8.08 *Inspections, Tests, and Approvals*

A. Owner's responsibility with respect to certain inspections, tests, and approvals is set forth in Paragraph 13.03.B.

8.09 *Limitations on Owner's Responsibilities*

A. The Owner shall not supervise, direct, or have control or authority over, nor be responsible for, Contractor's means, methods, techniques, sequences, or procedures of construction, or the safety precautions and programs incident thereto, or for any failure of Contractor to comply with Laws and Regulations applicable to the performance of the Work. Owner will not be responsible for Contractor's failure to perform the Work in accordance with the Contract Documents.

8.10 *Undisclosed Hazardous Environmental Condition*

A. Owner's responsibility in respect to an undisclosed Hazardous Environmental Condition is set forth in Paragraph 4.06.

8.11 *Evidence of Financial Arrangements*

A. Upon request of Contractor, Owner shall furnish Contractor reasonable evidence that financial arrangements have been made to satisfy Owner's obligations under the Contract Documents.

8.12 *Compliance with Safety Program*

A. While at the Site, Owner's employees and representatives shall comply with the specific applicable requirements of Contractor's safety programs of which Owner has been informed pursuant to Paragraph 6.13.D.

**ARTICLE 9 – ENGINEER'S STATUS DURING CONSTRUCTION**

9.01 *Owner's Representative*

A. Engineer will be Owner's representative during the construction period. The duties and responsibilities and the limitations of authority of Engineer as Owner's representative during construction are set forth in the Contract Documents.

9.02 *Visits to Site*

A. Engineer will make visits to the Site at intervals appropriate to the various stages of construction as Engineer deems necessary in order to observe as an experienced and qualified design professional the progress that has been made and the quality of the various aspects of Contractor's executed Work. Based on information obtained during such visits and observations, Engineer, for the benefit of Owner, will determine, in general, if the Work is proceeding in accordance with the Contract Documents. Engineer will not be required to make exhaustive or

continuous inspections on the Site to check the quality or quantity of the Work. Engineer's efforts will be directed toward providing for Owner a greater degree of confidence that the completed Work will conform generally to the Contract Documents. On the basis of such visits and observations, Engineer will keep Owner informed of the progress of the Work and will endeavor to guard Owner against defective Work.

- B. Engineer's visits and observations are subject to all the limitations on Engineer's authority and responsibility set forth in Paragraph 9.09. Particularly, but without limitation, during or as a result of Engineer's visits or observations of Contractor's Work, Engineer will not supervise, direct, control, or have authority over or be responsible for Contractor's means, methods, techniques, sequences, or procedures of construction, or the safety precautions and programs incident thereto, or for any failure of Contractor to comply with Laws and Regulations applicable to the performance of the Work.

#### 9.03 *Project Representative*

- A. If Owner and Engineer agree, Engineer will furnish a Resident Project Representative to assist Engineer in providing more extensive observation of the Work. The authority and responsibilities of any such Resident Project Representative and assistants will be as provided in the Supplementary Conditions, and limitations on the responsibilities thereof will be as provided in Paragraph 9.09. If Owner designates another representative or agent to represent Owner at the Site who is not Engineer's consultant, agent or employee, the responsibilities and authority and limitations thereon of such other individual or entity will be as provided in the Supplementary Conditions.

#### 9.04 *Authorized Variations in Work*

- A. Engineer may authorize minor variations in the Work from the requirements of the Contract Documents which do not involve an adjustment in the Contract Price or the Contract Times and are compatible with the design concept of the completed Project as a functioning whole as indicated by the Contract Documents. These may be accomplished by a Field Order and will be binding on Owner and also on Contractor, who shall perform the Work involved promptly. If Owner or Contractor believes that a Field Order justifies an adjustment in the Contract Price or Contract Times, or both, and the parties are unable to agree on entitlement to or on the amount or extent, if any, of any such adjustment, a Claim may be made therefor as provided in Paragraph 10.05.

#### 9.05 *Rejecting Defective Work*

- A. Engineer will have authority to reject Work which Engineer believes to be defective, or that Engineer believes will not produce a completed Project that conforms to the Contract Documents or that will prejudice the integrity of the design concept of the completed Project as a functioning whole as indicated by the Contract Documents. Engineer will also have authority to require special inspection or testing of the Work as provided in Paragraph 13.04, whether or not the Work is fabricated, installed, or completed.

9.06 *Shop Drawings, Change Orders and Payments*

- A. In connection with Engineer's authority, and limitations thereof, as to Shop Drawings and Samples, see Paragraph 6.17.
- B. In connection with Engineer's authority, and limitations thereof, as to design calculations and design drawings submitted in response to a delegation of professional design services, if any, see Paragraph 6.21.
- C. In connection with Engineer's authority as to Change Orders, see Articles 10, 11, and 12.
- D. In connection with Engineer's authority as to Applications for Payment, see Article 14.

9.07 *Determinations for Unit Price Work*

- A. Engineer will determine the actual quantities and classifications of Unit Price Work performed by Contractor. Engineer will review with Contractor the Engineer's preliminary determinations on such matters before rendering a written decision thereon (by recommendation of an Application for Payment or otherwise). Engineer's written decision thereon will be final and binding (except as modified by Engineer to reflect changed factual conditions or more accurate data) upon Owner and Contractor, subject to the provisions of Paragraph 10.05.

9.08 *Decisions on Requirements of Contract Documents and Acceptability of Work*

- A. Engineer will be the initial interpreter of the requirements of the Contract Documents and judge of the acceptability of the Work thereunder. All matters in question and other matters between Owner and Contractor arising prior to the date final payment is due relating to the acceptability of the Work, and the interpretation of the requirements of the Contract Documents pertaining to the performance of the Work, will be referred initially to Engineer in writing within 30 days of the event giving rise to the question.
- B. Engineer will, with reasonable promptness, render a written decision on the issue referred. If Owner or Contractor believes that any such decision entitles them to an adjustment in the Contract Price or Contract Times or both, a Claim may be made under Paragraph 10.05. The date of Engineer's decision shall be the date of the event giving rise to the issues referenced for the purposes of Paragraph 10.05.B.
- C. Engineer's written decision on the issue referred will be final and binding on Owner and Contractor, subject to the provisions of Paragraph 10.05.
- D. When functioning as interpreter and judge under this Paragraph 9.08, Engineer will not show partiality to Owner or Contractor and will not be liable in connection with any interpretation or decision rendered in good faith in such capacity.

9.09 *Limitations on Engineer's Authority and Responsibilities*

- A. Neither Engineer's authority or responsibility under this Article 9 or under any other provision of the Contract Documents nor any decision made by Engineer in good faith either to exercise or not

exercise such authority or responsibility or the undertaking, exercise, or performance of any authority or responsibility by Engineer shall create, impose, or give rise to any duty in contract, tort, or otherwise owed by Engineer to Contractor, any Subcontractor, any Supplier, any other individual or entity, or to any surety for or employee or agent of any of them.

- B. Engineer will not supervise, direct, control, or have authority over or be responsible for Contractor's means, methods, techniques, sequences, or procedures of construction, or the safety precautions and programs incident thereto, or for any failure of Contractor to comply with Laws and Regulations applicable to the performance of the Work. Engineer will not be responsible for Contractor's failure to perform the Work in accordance with the Contract Documents.
- C. Engineer will not be responsible for the acts or omissions of Contractor or of any Subcontractor, any Supplier, or of any other individual or entity performing any of the Work.
- D. Engineer's review of the final Application for Payment and accompanying documentation and all maintenance and operating instructions, schedules, guarantees, bonds, certificates of inspection, tests and approvals, and other documentation required to be delivered by Paragraph 14.07.A will only be to determine generally that their content complies with the requirements of, and in the case of certificates of inspections, tests, and approvals that the results certified indicate compliance with, the Contract Documents.
- E. The limitations upon authority and responsibility set forth in this Paragraph 9.09 shall also apply to the Resident Project Representative, if any, and assistants, if any.

#### 9.10 *Compliance with Safety Program*

- A. While at the Site, Engineer's employees and representatives shall comply with the specific applicable requirements of Contractor's safety programs of which Engineer has been informed pursuant to Paragraph 6.13.D.

### **ARTICLE 10 – CHANGES IN THE WORK; CLAIMS**

#### 10.01 *Authorized Changes in the Work*

- A. Without invalidating the Contract and without notice to any surety, Owner may, at any time or from time to time, order additions, deletions, or revisions in the Work by a Change Order, or a Work Change Directive. Upon receipt of any such document, Contractor shall promptly proceed with the Work involved which will be performed under the applicable conditions of the Contract Documents (except as otherwise specifically provided).
- B. If Owner and Contractor are unable to agree on entitlement to, or on the amount or extent, if any, of an adjustment in the Contract Price or Contract Times, or both, that should be allowed as a result of a Work Change Directive, a Claim may be made therefor as provided in Paragraph 10.05.

## 10.02 *Unauthorized Changes in the Work*

- A. Contractor shall not be entitled to an increase in the Contract Price or an extension of the Contract Times with respect to any work performed that is not required by the Contract Documents as amended, modified, or supplemented as provided in Paragraph 3.04, except in the case of an emergency as provided in Paragraph 6.16 or in the case of uncovering Work as provided in Paragraph 13.04.D.

## 10.03 *Execution of Change Orders*

- A. Owner and Contractor shall execute appropriate Change Orders recommended by Engineer covering:
  - 1. changes in the Work which are: (i) ordered by Owner pursuant to Paragraph 10.01.A, (ii) required because of acceptance of defective Work under Paragraph 13.08.A or Owner's correction of defective Work under Paragraph 13.09, or (iii) agreed to by the parties;
  - 2. changes in the Contract Price or Contract Times which are agreed to by the parties, including any undisputed sum or amount of time for Work actually performed in accordance with a Work Change Directive; and
  - 3. changes in the Contract Price or Contract Times which embody the substance of any written decision rendered by Engineer pursuant to Paragraph 10.05; provided that, in lieu of executing any such Change Order, an appeal may be taken from any such decision in accordance with the provisions of the Contract Documents and applicable Laws and Regulations, but during any such appeal, Contractor shall carry on the Work and adhere to the Progress Schedule as provided in Paragraph 6.18.A.

## 10.04 *Notification to Surety*

- A. If the provisions of any bond require notice to be given to a surety of any change affecting the general scope of the Work or the provisions of the Contract Documents (including, but not limited to, Contract Price or Contract Times), the giving of any such notice will be Contractor's responsibility. The amount of each applicable bond will be adjusted to reflect the effect of any such change.

## 10.05 *Claims*

- A. *Engineer's Decision Required:* All Claims, except those waived pursuant to Paragraph 14.09, shall be referred to the Engineer for decision. A decision by Engineer shall be required as a condition precedent to any exercise by Owner or Contractor of any rights or remedies either may otherwise have under the Contract Documents or by Laws and Regulations in respect of such Claims.
- B. *Notice:* Written notice stating the general nature of each Claim shall be delivered by the claimant to Engineer and the other party to the Contract promptly (but in no event later than 30 days) after the start of the event giving rise thereto. The responsibility to substantiate a Claim shall rest with the party making the Claim. Notice of the amount or extent of the Claim, with supporting data

shall be delivered to the Engineer and the other party to the Contract within 60 days after the start of such event (unless Engineer allows additional time for claimant to submit additional or more accurate data in support of such Claim). A Claim for an adjustment in Contract Price shall be prepared in accordance with the provisions of Paragraph 12.01.B. A Claim for an adjustment in Contract Times shall be prepared in accordance with the provisions of Paragraph 12.02.B. Each Claim shall be accompanied by claimant's written statement that the adjustment claimed is the entire adjustment to which the claimant believes it is entitled as a result of said event. The opposing party shall submit any response to Engineer and the claimant within 30 days after receipt of the claimant's last submittal (unless Engineer allows additional time).

- C. *Engineer's Action:* Engineer will review each Claim and, within 30 days after receipt of the last submittal of the claimant or the last submittal of the opposing party, if any, take one of the following actions in writing:
1. deny the Claim in whole or in part;
  2. approve the Claim; or
  3. notify the parties that the Engineer is unable to resolve the Claim if, in the Engineer's sole discretion, it would be inappropriate for the Engineer to do so. For purposes of further resolution of the Claim, such notice shall be deemed a denial.
- D. In the event that Engineer does not take action on a Claim within said 30 days, the Claim shall be deemed denied.
- E. Engineer's written action under Paragraph 10.05.C or denial pursuant to Paragraphs 10.05.C.3 or 10.05.D will be final and binding upon Owner and Contractor, unless Owner or Contractor invoke the dispute resolution procedure set forth in Article 16 within 30 days of such action or denial.
- F. No Claim for an adjustment in Contract Price or Contract Times will be valid if not submitted in accordance with this Paragraph 10.05.

## **ARTICLE 11 – COST OF THE WORK; ALLOWANCES; UNIT PRICE WORK**

### **11.01 *Cost of the Work***

- A. *Costs Included:* The term Cost of the Work means the sum of all costs, except those excluded in Paragraph 11.01.B, necessarily incurred and paid by Contractor in the proper performance of the Work. When the value of any Work covered by a Change Order or when a Claim for an adjustment in Contract Price is determined on the basis of Cost of the Work, the costs to be reimbursed to Contractor will be only those additional or incremental costs required because of the change in the Work or because of the event giving rise to the Claim. Except as otherwise may be agreed to in writing by Owner, such costs shall be in amounts no higher than those prevailing in the locality of the Project, shall not include any of the costs itemized in Paragraph 11.01.B, and shall include only the following items:



1. Payroll costs for employees in the direct employ of Contractor in the performance of the Work under schedules of job classifications agreed upon by Owner and Contractor. Such employees shall include, without limitation, superintendents, foremen, and other personnel employed full time on the Work. Payroll costs for employees not employed full time on the Work shall be apportioned on the basis of their time spent on the Work. Payroll costs shall include, but not be limited to, salaries and wages plus the cost of fringe benefits, which shall include social security contributions, unemployment, excise, and payroll taxes, workers' compensation, health and retirement benefits, bonuses, sick leave, vacation and holiday pay applicable thereto. The expenses of performing Work outside of regular working hours, on Saturday, Sunday, or legal holidays, shall be included in the above to the extent authorized by Owner.
2. Cost of all materials and equipment furnished and incorporated in the Work, including costs of transportation and storage thereof, and Suppliers' field services required in connection therewith. All cash discounts shall accrue to Contractor unless Owner deposits funds with Contractor with which to make payments, in which case the cash discounts shall accrue to Owner. All trade discounts, rebates and refunds and returns from sale of surplus materials and equipment shall accrue to Owner, and Contractor shall make provisions so that they may be obtained.
3. Payments made by Contractor to Subcontractors for Work performed by Subcontractors. If required by Owner, Contractor shall obtain competitive bids from subcontractors acceptable to Owner and Contractor and shall deliver such bids to Owner, who will then determine, with the advice of Engineer, which bids, if any, will be acceptable. If any subcontract provides that the Subcontractor is to be paid on the basis of Cost of the Work plus a fee, the Subcontractor's Cost of the Work and fee shall be determined in the same manner as Contractor's Cost of the Work and fee as provided in this Paragraph 11.01.
4. Costs of special consultants (including but not limited to engineers, architects, testing laboratories, surveyors, attorneys, and accountants) employed for services specifically related to the Work.
5. Supplemental costs including the following:
  - a. The proportion of necessary transportation, travel, and subsistence expenses of Contractor's employees incurred in discharge of duties connected with the Work.
  - b. Cost, including transportation and maintenance, of all materials, supplies, equipment, machinery, appliances, office, and temporary facilities at the Site, and hand tools not owned by the workers, which are consumed in the performance of the Work, and cost, less market value, of such items used but not consumed which remain the property of Contractor.
  - c. Rentals of all construction equipment and machinery, and the parts thereof whether rented from Contractor or others in accordance with rental agreements approved by Owner with the advice of Engineer, and the costs of transportation, loading, unloading, assembly, dismantling, and removal thereof. All such costs shall be in accordance with the terms of

said rental agreements. The rental of any such equipment, machinery, or parts shall cease when the use thereof is no longer necessary for the Work.

- d. Sales, consumer, use, and other similar taxes related to the Work, and for which Contractor is liable, as imposed by Laws and Regulations.
- e. Deposits lost for causes other than negligence of Contractor, any Subcontractor, or anyone directly or indirectly employed by any of them or for whose acts any of them may be liable, and royalty payments and fees for permits and licenses.
- f. Losses and damages (and related expenses) caused by damage to the Work, not compensated by insurance or otherwise, sustained by Contractor in connection with the performance of the Work (except losses and damages within the deductible amounts of property insurance established in accordance with Paragraph 5.06.D), provided such losses and damages have resulted from causes other than the negligence of Contractor, any Subcontractor, or anyone directly or indirectly employed by any of them or for whose acts any of them may be liable. Such losses shall include settlements made with the written consent and approval of Owner. No such losses, damages, and expenses shall be included in the Cost of the Work for the purpose of determining Contractor's fee.
- g. The cost of utilities, fuel, and sanitary facilities at the Site.
- h. Minor expenses such as telegrams, long distance telephone calls, telephone service at the Site, express and courier services, and similar petty cash items in connection with the Work.
- i. The costs of premiums for all bonds and insurance Contractor is required by the Contract Documents to purchase and maintain.

B. *Costs Excluded:* The term Cost of the Work shall not include any of the following items:

- 1. Payroll costs and other compensation of Contractor's officers, executives, principals (of partnerships and sole proprietorships), general managers, safety managers, engineers, architects, estimators, attorneys, auditors, accountants, purchasing and contracting agents, expeditors, timekeepers, clerks, and other personnel employed by Contractor, whether at the Site or in Contractor's principal or branch office for general administration of the Work and not specifically included in the agreed upon schedule of job classifications referred to in Paragraph 11.01.A.1 or specifically covered by Paragraph 11.01.A.4, all of which are to be considered administrative costs covered by the Contractor's fee.
- 2. Expenses of Contractor's principal and branch offices other than Contractor's office at the Site.
- 3. Any part of Contractor's capital expenses, including interest on Contractor's capital employed for the Work and charges against Contractor for delinquent payments.
- 4. Costs due to the negligence of Contractor, any Subcontractor, or anyone directly or indirectly employed by any of them or for whose acts any of them may be liable, including but not

limited to, the correction of defective Work, disposal of materials or equipment wrongly supplied, and making good any damage to property.

5. Other overhead or general expense costs of any kind and the costs of any item not specifically and expressly included in Paragraphs 11.01.A.
- C. *Contractor's Fee:* When all the Work is performed on the basis of cost-plus, Contractor's fee shall be determined as set forth in the Agreement. When the value of any Work covered by a Change Order or when a Claim for an adjustment in Contract Price is determined on the basis of Cost of the Work, Contractor's fee shall be determined as set forth in Paragraph 12.01.C.
- D. *Documentation:* Whenever the Cost of the Work for any purpose is to be determined pursuant to Paragraphs 11.01.A and 11.01.B, Contractor will establish and maintain records thereof in accordance with generally accepted accounting practices and submit in a form acceptable to Engineer an itemized cost breakdown together with supporting data.

#### 11.02 Allowances

- A. It is understood that Contractor has included in the Contract Price all allowances so named in the Contract Documents and shall cause the Work so covered to be performed for such sums and by such persons or entities as may be acceptable to Owner and Engineer.
- B. *Cash Allowances:*
  1. Contractor agrees that:
    - a. the cash allowances include the cost to Contractor (less any applicable trade discounts) of materials and equipment required by the allowances to be delivered at the Site, and all applicable taxes; and
    - b. Contractor's costs for unloading and handling on the Site, labor, installation, overhead, profit, and other expenses contemplated for the cash allowances have been included in the Contract Price and not in the allowances, and no demand for additional payment on account of any of the foregoing will be valid.
- C. *Contingency Allowance:*
  1. Contractor agrees that a contingency allowance, if any, is for the sole use of Owner to cover unanticipated costs.
- D. Prior to final payment, an appropriate Change Order will be issued as recommended by Engineer to reflect actual amounts due Contractor on account of Work covered by allowances, and the Contract Price shall be correspondingly adjusted.

#### 11.03 Unit Price Work

- A. Where the Contract Documents provide that all or part of the Work is to be Unit Price Work, initially the Contract Price will be deemed to include for all Unit Price Work an amount equal to

the sum of the unit price for each separately identified item of Unit Price Work times the estimated quantity of each item as indicated in the Agreement.

- B. The estimated quantities of items of Unit Price Work are not guaranteed and are solely for the purpose of comparison of Bids and determining an initial Contract Price. Determinations of the actual quantities and classifications of Unit Price Work performed by Contractor will be made by Engineer subject to the provisions of Paragraph 9.07.
- C. Each unit price will be deemed to include an amount considered by Contractor to be adequate to cover Contractor's overhead and profit for each separately identified item.
- D. Owner or Contractor may make a Claim for an adjustment in the Contract Price in accordance with Paragraph 10.05 if:
  - 1. the quantity of any item of Unit Price Work performed by Contractor differs materially and significantly from the estimated quantity of such item indicated in the Agreement; and
  - 2. there is no corresponding adjustment with respect to any other item of Work; and
  - 3. Contractor believes that Contractor is entitled to an increase in Contract Price as a result of having incurred additional expense or Owner believes that Owner is entitled to a decrease in Contract Price and the parties are unable to agree as to the amount of any such increase or decrease.

## **ARTICLE 12 – CHANGE OF CONTRACT PRICE; CHANGE OF CONTRACT TIMES**

### *12.01 Change of Contract Price*

- A. The Contract Price may only be changed by a Change Order. Any Claim for an adjustment in the Contract Price shall be based on written notice submitted by the party making the Claim to the Engineer and the other party to the Contract in accordance with the provisions of Paragraph 10.05.
- B. The value of any Work covered by a Change Order or of any Claim for an adjustment in the Contract Price will be determined as follows:
  - 1. where the Work involved is covered by unit prices contained in the Contract Documents, by application of such unit prices to the quantities of the items involved (subject to the provisions of Paragraph 11.03); or
  - 2. where the Work involved is not covered by unit prices contained in the Contract Documents, by a mutually agreed lump sum (which may include an allowance for overhead and profit not necessarily in accordance with Paragraph 12.01.C.2); or
  - 3. where the Work involved is not covered by unit prices contained in the Contract Documents and agreement to a lump sum is not reached under Paragraph 12.01.B.2, on the basis of the Cost of the Work (determined as provided in Paragraph 11.01) plus a Contractor's fee for overhead and profit (determined as provided in Paragraph 12.01.C).

C. *Contractor's Fee*: The Contractor's fee for overhead and profit shall be determined as follows:

1. a mutually acceptable fixed fee; or
2. if a fixed fee is not agreed upon, then a fee based on the following percentages of the various portions of the Cost of the Work:
  - a. for costs incurred under Paragraphs 11.01.A.1 and 11.01.A.2, the Contractor's fee shall be 15 percent;
  - b. for costs incurred under Paragraph 11.01.A.3, the Contractor's fee shall be five percent;
  - c. where one or more tiers of subcontracts are on the basis of Cost of the Work plus a fee and no fixed fee is agreed upon, the intent of Paragraphs 12.01.C.2.a and 12.01.C.2.b is that the Subcontractor who actually performs the Work, at whatever tier, will be paid a fee of 15 percent of the costs incurred by such Subcontractor under Paragraphs 11.01.A.1 and 11.01.A.2 and that any higher tier Subcontractor and Contractor will each be paid a fee of five percent of the amount paid to the next lower tier Subcontractor;
  - d. no fee shall be payable on the basis of costs itemized under Paragraphs 11.01.A.4, 11.01.A.5, and 11.01.B;
  - e. the amount of credit to be allowed by Contractor to Owner for any change which results in a net decrease in cost will be the amount of the actual net decrease in cost plus a deduction in Contractor's fee by an amount equal to five percent of such net decrease; and
  - f. when both additions and credits are involved in any one change, the adjustment in Contractor's fee shall be computed on the basis of the net change in accordance with Paragraphs 12.01.C.2.a through 12.01.C.2.e, inclusive.

#### 12.02 *Change of Contract Times*

- A. The Contract Times may only be changed by a Change Order. Any Claim for an adjustment in the Contract Times shall be based on written notice submitted by the party making the Claim to the Engineer and the other party to the Contract in accordance with the provisions of Paragraph 10.05.
- B. Any adjustment of the Contract Times covered by a Change Order or any Claim for an adjustment in the Contract Times will be determined in accordance with the provisions of this Article 12.

#### 12.03 *Delays*

- A. Where Contractor is prevented from completing any part of the Work within the Contract Times due to delay beyond the control of Contractor, the Contract Times will be extended in an amount equal to the time lost due to such delay if a Claim is made therefor as provided in Paragraph 12.02.A. Delays beyond the control of Contractor shall include, but not be limited to, acts or

neglect by Owner, acts or neglect of utility owners or other contractors performing other work as contemplated by Article 7, fires, floods, epidemics, abnormal weather conditions, or acts of God.

- B. If Owner, Engineer, or other contractors or utility owners performing other work for Owner as contemplated by Article 7, or anyone for whom Owner is responsible, delays, disrupts, or interferes with the performance or progress of the Work, then Contractor shall be entitled to an equitable adjustment in the Contract Price or the Contract Times, or both. Contractor's entitlement to an adjustment of the Contract Times is conditioned on such adjustment being essential to Contractor's ability to complete the Work within the Contract Times.
- C. If Contractor is delayed in the performance or progress of the Work by fire, flood, epidemic, abnormal weather conditions, acts of God, acts or failures to act of utility owners not under the control of Owner, or other causes not the fault of and beyond control of Owner and Contractor, then Contractor shall be entitled to an equitable adjustment in Contract Times, if such adjustment is essential to Contractor's ability to complete the Work within the Contract Times. Such an adjustment shall be Contractor's sole and exclusive remedy for the delays described in this Paragraph 12.03.C.
- D. Owner, Engineer, and their officers, directors, members, partners, employees, agents, consultants, or subcontractors shall not be liable to Contractor for any claims, costs, losses, or damages (including but not limited to all fees and charges of engineers, architects, attorneys, and other professionals and all court or arbitration or other dispute resolution costs) sustained by Contractor on or in connection with any other project or anticipated project.
- E. Contractor shall not be entitled to an adjustment in Contract Price or Contract Times for delays within the control of Contractor. Delays attributable to and within the control of a Subcontractor or Supplier shall be deemed to be delays within the control of Contractor.

## **ARTICLE 13 – TESTS AND INSPECTIONS; CORRECTION, REMOVAL OR ACCEPTANCE OF DEFECTIVE WORK**

### *13.01 Notice of Defects*

- A. Prompt notice of all defective Work of which Owner or Engineer has actual knowledge will be given to Contractor. Defective Work may be rejected, corrected, or accepted as provided in this Article 13.

### *13.02 Access to Work*

- A. Owner, Engineer, their consultants and other representatives and personnel of Owner, independent testing laboratories, and governmental agencies with jurisdictional interests will have access to the Site and the Work at reasonable times for their observation, inspection, and testing. Contractor shall provide them proper and safe conditions for such access and advise them of Contractor's safety procedures and programs so that they may comply therewith as applicable.

### 13.03 *Tests and Inspections*

- A. Contractor shall give Engineer timely notice of readiness of the Work for all required inspections, tests, or approvals and shall cooperate with inspection and testing personnel to facilitate required inspections or tests.
- B. Owner shall employ and pay for the services of an independent testing laboratory to perform all inspections, tests, or approvals required by the Contract Documents except:
  - 1. for inspections, tests, or approvals covered by Paragraphs 13.03.C and 13.03.D below;
  - 2. that costs incurred in connection with tests or inspections conducted pursuant to Paragraph 13.04.B shall be paid as provided in Paragraph 13.04.C; and
  - 3. as otherwise specifically provided in the Contract Documents.
- C. If Laws or Regulations of any public body having jurisdiction require any Work (or part thereof) specifically to be inspected, tested, or approved by an employee or other representative of such public body, Contractor shall assume full responsibility for arranging and obtaining such inspections, tests, or approvals, pay all costs in connection therewith, and furnish Engineer the required certificates of inspection or approval.
- D. Contractor shall be responsible for arranging and obtaining and shall pay all costs in connection with any inspections, tests, or approvals required for Owner's and Engineer's acceptance of materials or equipment to be incorporated in the Work; or acceptance of materials, mix designs, or equipment submitted for approval prior to Contractor's purchase thereof for incorporation in the Work. Such inspections, tests, or approvals shall be performed by organizations acceptable to Owner and Engineer.
- E. If any Work (or the work of others) that is to be inspected, tested, or approved is covered by Contractor without written concurrence of Engineer, Contractor shall, if requested by Engineer, uncover such Work for observation.
- F. Uncovering Work as provided in Paragraph 13.03.E shall be at Contractor's expense unless Contractor has given Engineer timely notice of Contractor's intention to cover the same and Engineer has not acted with reasonable promptness in response to such notice.

### 13.04 *Uncovering Work*

- A. If any Work is covered contrary to the written request of Engineer, it must, if requested by Engineer, be uncovered for Engineer's observation and replaced at Contractor's expense.
- B. If Engineer considers it necessary or advisable that covered Work be observed by Engineer or inspected or tested by others, Contractor, at Engineer's request, shall uncover, expose, or otherwise make available for observation, inspection, or testing as Engineer may require, that portion of the Work in question, furnishing all necessary labor, material, and equipment.

- C. If it is found that the uncovered Work is defective, Contractor shall pay all claims, costs, losses, and damages (including but not limited to all fees and charges of engineers, architects, attorneys, and other professionals and all court or arbitration or other dispute resolution costs) arising out of or relating to such uncovering, exposure, observation, inspection, and testing, and of satisfactory replacement or reconstruction (including but not limited to all costs of repair or replacement of work of others); and Owner shall be entitled to an appropriate decrease in the Contract Price. If the parties are unable to agree as to the amount thereof, Owner may make a Claim therefor as provided in Paragraph 10.05.
- D. If the uncovered Work is not found to be defective, Contractor shall be allowed an increase in the Contract Price or an extension of the Contract Times, or both, directly attributable to such uncovering, exposure, observation, inspection, testing, replacement, and reconstruction. If the parties are unable to agree as to the amount or extent thereof, Contractor may make a Claim therefor as provided in Paragraph 10.05.

#### 13.05 *Owner May Stop the Work*

- A. If the Work is defective, or Contractor fails to supply sufficient skilled workers or suitable materials or equipment, or fails to perform the Work in such a way that the completed Work will conform to the Contract Documents, Owner may order Contractor to stop the Work, or any portion thereof, until the cause for such order has been eliminated; however, this right of Owner to stop the Work shall not give rise to any duty on the part of Owner to exercise this right for the benefit of Contractor, any Subcontractor, any Supplier, any other individual or entity, or any surety for, or employee or agent of any of them.

#### 13.06 *Correction or Removal of Defective Work*

- A. Promptly after receipt of written notice, Contractor shall correct all defective Work, whether or not fabricated, installed, or completed, or, if the Work has been rejected by Engineer, remove it from the Project and replace it with Work that is not defective. Contractor shall pay all claims, costs, losses, and damages (including but not limited to all fees and charges of engineers, architects, attorneys, and other professionals and all court or arbitration or other dispute resolution costs) arising out of or relating to such correction or removal (including but not limited to all costs of repair or replacement of work of others).
- B. When correcting defective Work under the terms of this Paragraph 13.06 or Paragraph 13.07, Contractor shall take no action that would void or otherwise impair Owner's special warranty and guarantee, if any, on said Work.

#### 13.07 *Correction Period*

- A. If within one year after the date of Substantial Completion (or such longer period of time as may be prescribed by the terms of any applicable special guarantee required by the Contract Documents) or by any specific provision of the Contract Documents, any Work is found to be defective, or if the repair of any damages to the land or areas made available for Contractor's use by Owner or permitted by Laws and Regulations as contemplated in Paragraph 6.11.A is found to be defective, Contractor shall promptly, without cost to Owner and in accordance with Owner's written instructions:



1. repair such defective land or areas; or
  2. correct such defective Work; or
  3. if the defective Work has been rejected by Owner, remove it from the Project and replace it with Work that is not defective, and
  4. satisfactorily correct or repair or remove and replace any damage to other Work, to the work of others or other land or areas resulting therefrom.
- B. If Contractor does not promptly comply with the terms of Owner's written instructions, or in an emergency where delay would cause serious risk of loss or damage, Owner may have the defective Work corrected or repaired or may have the rejected Work removed and replaced. All claims, costs, losses, and damages (including but not limited to all fees and charges of engineers, architects, attorneys, and other professionals and all court or arbitration or other dispute resolution costs) arising out of or relating to such correction or repair or such removal and replacement (including but not limited to all costs of repair or replacement of work of others) will be paid by Contractor.
- C. In special circumstances where a particular item of equipment is placed in continuous service before Substantial Completion of all the Work, the correction period for that item may start to run from an earlier date if so provided in the Specifications.
- D. Where defective Work (and damage to other Work resulting therefrom) has been corrected or removed and replaced under this Paragraph 13.07, the correction period hereunder with respect to such Work will be extended for an additional period of one year after such correction or removal and replacement has been satisfactorily completed.
- E. Contractor's obligations under this Paragraph 13.07 are in addition to any other obligation or warranty. The provisions of this Paragraph 13.07 shall not be construed as a substitute for, or a waiver of, the provisions of any applicable statute of limitation or repose.

#### 13.08 *Acceptance of Defective Work*

- A. If, instead of requiring correction or removal and replacement of defective Work, Owner (and, prior to Engineer's recommendation of final payment, Engineer) prefers to accept it, Owner may do so. Contractor shall pay all claims, costs, losses, and damages (including but not limited to all fees and charges of engineers, architects, attorneys, and other professionals and all court or arbitration or other dispute resolution costs) attributable to Owner's evaluation of and determination to accept such defective Work (such costs to be approved by Engineer as to reasonableness) and for the diminished value of the Work to the extent not otherwise paid by Contractor pursuant to this sentence. If any such acceptance occurs prior to Engineer's recommendation of final payment, a Change Order will be issued incorporating the necessary revisions in the Contract Documents with respect to the Work, and Owner shall be entitled to an appropriate decrease in the Contract Price, reflecting the diminished value of Work so accepted. If the parties are unable to agree as to the amount thereof, Owner may make a Claim therefor as provided in Paragraph 10.05. If the acceptance occurs after such recommendation, an appropriate amount will be paid by Contractor to Owner.

### 13.09 *Owner May Correct Defective Work*

- A. If Contractor fails within a reasonable time after written notice from Engineer to correct defective Work, or to remove and replace rejected Work as required by Engineer in accordance with Paragraph 13.06.A, or if Contractor fails to perform the Work in accordance with the Contract Documents, or if Contractor fails to comply with any other provision of the Contract Documents, Owner may, after seven days written notice to Contractor, correct, or remedy any such deficiency.
- B. In exercising the rights and remedies under this Paragraph 13.09, Owner shall proceed expeditiously. In connection with such corrective or remedial action, Owner may exclude Contractor from all or part of the Site, take possession of all or part of the Work and suspend Contractor's services related thereto, take possession of Contractor's tools, appliances, construction equipment and machinery at the Site, and incorporate in the Work all materials and equipment stored at the Site or for which Owner has paid Contractor but which are stored elsewhere. Contractor shall allow Owner, Owner's representatives, agents and employees, Owner's other contractors, and Engineer and Engineer's consultants access to the Site to enable Owner to exercise the rights and remedies under this Paragraph.
- C. All claims, costs, losses, and damages (including but not limited to all fees and charges of engineers, architects, attorneys, and other professionals and all court or arbitration or other dispute resolution costs) incurred or sustained by Owner in exercising the rights and remedies under this Paragraph 13.09 will be charged against Contractor, and a Change Order will be issued incorporating the necessary revisions in the Contract Documents with respect to the Work; and Owner shall be entitled to an appropriate decrease in the Contract Price. If the parties are unable to agree as to the amount of the adjustment, Owner may make a Claim therefor as provided in Paragraph 10.05. Such claims, costs, losses and damages will include but not be limited to all costs of repair, or replacement of work of others destroyed or damaged by correction, removal, or replacement of Contractor's defective Work.
- D. Contractor shall not be allowed an extension of the Contract Times because of any delay in the performance of the Work attributable to the exercise by Owner of Owner's rights and remedies under this Paragraph 13.09.

## **ARTICLE 14 – PAYMENTS TO CONTRACTOR AND COMPLETION**

### 14.01 *Schedule of Values*

- A. The Schedule of Values established as provided in Paragraph 2.07.A will serve as the basis for progress payments and will be incorporated into a form of Application for Payment acceptable to Engineer. Progress payments on account of Unit Price Work will be based on the number of units completed.

### 14.02 *Progress Payments*

#### A. *Applications for Payments:*

- 1. At least 20 days before the date established in the Agreement for each progress payment (but not more often than once a month), Contractor shall submit to Engineer for review an

Application for Payment filled out and signed by Contractor covering the Work completed as of the date of the Application and accompanied by such supporting documentation as is required by the Contract Documents. If payment is requested on the basis of materials and equipment not incorporated in the Work but delivered and suitably stored at the Site or at another location agreed to in writing, the Application for Payment shall also be accompanied by a bill of sale, invoice, or other documentation warranting that Owner has received the materials and equipment free and clear of all Liens and evidence that the materials and equipment are covered by appropriate property insurance or other arrangements to protect Owner's interest therein, all of which must be satisfactory to Owner.

2. Beginning with the second Application for Payment, each Application shall include an affidavit of Contractor stating that all previous progress payments received on account of the Work have been applied on account to discharge Contractor's legitimate obligations associated with prior Applications for Payment.
3. The amount of retainage with respect to progress payments will be as stipulated in the Agreement.

**B. *Review of Applications:***

1. Engineer will, within 10 days after receipt of each Application for Payment, either indicate in writing a recommendation of payment and present the Application to Owner or return the Application to Contractor indicating in writing Engineer's reasons for refusing to recommend payment. In the latter case, Contractor may make the necessary corrections and resubmit the Application.
2. Engineer's recommendation of any payment requested in an Application for Payment will constitute a representation by Engineer to Owner, based on Engineer's observations of the executed Work as an experienced and qualified design professional, and on Engineer's review of the Application for Payment and the accompanying data and schedules, that to the best of Engineer's knowledge, information and belief:
  - a. the Work has progressed to the point indicated;
  - b. the quality of the Work is generally in accordance with the Contract Documents (subject to an evaluation of the Work as a functioning whole prior to or upon Substantial Completion, the results of any subsequent tests called for in the Contract Documents, a final determination of quantities and classifications for Unit Price Work under Paragraph 9.07, and any other qualifications stated in the recommendation); and
  - c. the conditions precedent to Contractor's being entitled to such payment appear to have been fulfilled in so far as it is Engineer's responsibility to observe the Work.
3. By recommending any such payment Engineer will not thereby be deemed to have represented that:
  - a. inspections made to check the quality or the quantity of the Work as it has been performed have been exhaustive, extended to every aspect of the Work in progress, or

- involved detailed inspections of the Work beyond the responsibilities specifically assigned to Engineer in the Contract Documents; or
- b. there may not be other matters or issues between the parties that might entitle Contractor to be paid additionally by Owner or entitle Owner to withhold payment to Contractor.
4. Neither Engineer's review of Contractor's Work for the purposes of recommending payments nor Engineer's recommendation of any payment, including final payment, will impose responsibility on Engineer:
    - a. to supervise, direct, or control the Work, or
    - b. for the means, methods, techniques, sequences, or procedures of construction, or the safety precautions and programs incident thereto, or
    - c. for Contractor's failure to comply with Laws and Regulations applicable to Contractor's performance of the Work, or
    - d. to make any examination to ascertain how or for what purposes Contractor has used the moneys paid on account of the Contract Price, or
    - e. to determine that title to any of the Work, materials, or equipment has passed to Owner free and clear of any Liens.
  5. Engineer may refuse to recommend the whole or any part of any payment if, in Engineer's opinion, it would be incorrect to make the representations to Owner stated in Paragraph 14.02.B.2. Engineer may also refuse to recommend any such payment or, because of subsequently discovered evidence or the results of subsequent inspections or tests, revise or revoke any such payment recommendation previously made, to such extent as may be necessary in Engineer's opinion to protect Owner from loss because:
    - a. the Work is defective, or completed Work has been damaged, requiring correction or replacement;
    - b. the Contract Price has been reduced by Change Orders;
    - c. Owner has been required to correct defective Work or complete Work in accordance with Paragraph 13.09; or
    - d. Engineer has actual knowledge of the occurrence of any of the events enumerated in Paragraph 15.02.A.

*C. Payment Becomes Due:*

1. Ten days after presentation of the Application for Payment to Owner with Engineer's recommendation, the amount recommended will (subject to the provisions of Paragraph 14.02.D) become due, and when due will be paid by Owner to Contractor.

D. *Reduction in Payment:*

1. Owner may refuse to make payment of the full amount recommended by Engineer because:
  - a. claims have been made against Owner on account of Contractor's performance or furnishing of the Work;
  - b. Liens have been filed in connection with the Work, except where Contractor has delivered a specific bond satisfactory to Owner to secure the satisfaction and discharge of such Liens;
  - c. there are other items entitling Owner to a set-off against the amount recommended; or
  - d. Owner has actual knowledge of the occurrence of any of the events enumerated in Paragraphs 14.02.B.5.a through 14.02.B.5.c or Paragraph 15.02.A.
2. If Owner refuses to make payment of the full amount recommended by Engineer, Owner will give Contractor immediate written notice (with a copy to Engineer) stating the reasons for such action and promptly pay Contractor any amount remaining after deduction of the amount so withheld. Owner shall promptly pay Contractor the amount so withheld, or any adjustment thereto agreed to by Owner and Contractor, when Contractor remedies the reasons for such action.
3. Upon a subsequent determination that Owner's refusal of payment was not justified, the amount wrongfully withheld shall be treated as an amount due as determined by Paragraph 14.02.C.1 and subject to interest as provided in the Agreement.

14.03 *Contractor's Warranty of Title*

- A. Contractor warrants and guarantees that title to all Work, materials, and equipment covered by any Application for Payment, whether incorporated in the Project or not, will pass to Owner no later than the time of payment free and clear of all Liens.

14.04 *Substantial Completion*

- A. When Contractor considers the entire Work ready for its intended use Contractor shall notify Owner and Engineer in writing that the entire Work is substantially complete (except for items specifically listed by Contractor as incomplete) and request that Engineer issue a certificate of Substantial Completion.
- B. Promptly after Contractor's notification, Owner, Contractor, and Engineer shall make an inspection of the Work to determine the status of completion. If Engineer does not consider the Work substantially complete, Engineer will notify Contractor in writing giving the reasons therefor.
- C. If Engineer considers the Work substantially complete, Engineer will deliver to Owner a tentative certificate of Substantial Completion which shall fix the date of Substantial Completion. There shall be attached to the certificate a tentative list of items to be completed or corrected before

final payment. Owner shall have seven days after receipt of the tentative certificate during which to make written objection to Engineer as to any provisions of the certificate or attached list. If, after considering such objections, Engineer concludes that the Work is not substantially complete, Engineer will, within 14 days after submission of the tentative certificate to Owner, notify Contractor in writing, stating the reasons therefor. If, after consideration of Owner's objections, Engineer considers the Work substantially complete, Engineer will, within said 14 days, execute and deliver to Owner and Contractor a definitive certificate of Substantial Completion (with a revised tentative list of items to be completed or corrected) reflecting such changes from the tentative certificate as Engineer believes justified after consideration of any objections from Owner.

- D. At the time of delivery of the tentative certificate of Substantial Completion, Engineer will deliver to Owner and Contractor a written recommendation as to division of responsibilities pending final payment between Owner and Contractor with respect to security, operation, safety, and protection of the Work, maintenance, heat, utilities, insurance, and warranties and guarantees. Unless Owner and Contractor agree otherwise in writing and so inform Engineer in writing prior to Engineer's issuing the definitive certificate of Substantial Completion, Engineer's aforesaid recommendation will be binding on Owner and Contractor until final payment.
- E. Owner shall have the right to exclude Contractor from the Site after the date of Substantial Completion subject to allowing Contractor reasonable access to remove its property and complete or correct items on the tentative list.

#### 14.05 *Partial Utilization*

- A. Prior to Substantial Completion of all the Work, Owner may use or occupy any substantially completed part of the Work which has specifically been identified in the Contract Documents, or which Owner, Engineer, and Contractor agree constitutes a separately functioning and usable part of the Work that can be used by Owner for its intended purpose without significant interference with Contractor's performance of the remainder of the Work, subject to the following conditions:
  - 1. Owner at any time may request Contractor in writing to permit Owner to use or occupy any such part of the Work which Owner believes to be ready for its intended use and substantially complete. If and when Contractor agrees that such part of the Work is substantially complete, Contractor, Owner, and Engineer will follow the procedures of Paragraph 14.04.A through D for that part of the Work.
  - 2. Contractor at any time may notify Owner and Engineer in writing that Contractor considers any such part of the Work ready for its intended use and substantially complete and request Engineer to issue a certificate of Substantial Completion for that part of the Work.
  - 3. Within a reasonable time after either such request, Owner, Contractor, and Engineer shall make an inspection of that part of the Work to determine its status of completion. If Engineer does not consider that part of the Work to be substantially complete, Engineer will notify Owner and Contractor in writing giving the reasons therefor. If Engineer considers that part of the Work to be substantially complete, the provisions of Paragraph 14.04 will apply with respect to certification of Substantial Completion of that part of the Work and the division of responsibility in respect thereof and access thereto.

4. No use or occupancy or separate operation of part of the Work may occur prior to compliance with the requirements of Paragraph 5.10 regarding property insurance.

#### 14.06 *Final Inspection*

- A. Upon written notice from Contractor that the entire Work or an agreed portion thereof is complete, Engineer will promptly make a final inspection with Owner and Contractor and will notify Contractor in writing of all particulars in which this inspection reveals that the Work is incomplete or defective. Contractor shall immediately take such measures as are necessary to complete such Work or remedy such deficiencies.

#### 14.07 *Final Payment*

##### A. *Application for Payment:*

1. After Contractor has, in the opinion of Engineer, satisfactorily completed all corrections identified during the final inspection and has delivered, in accordance with the Contract Documents, all maintenance and operating instructions, schedules, guarantees, bonds, certificates or other evidence of insurance, certificates of inspection, marked-up record documents (as provided in Paragraph 6.12), and other documents, Contractor may make application for final payment following the procedure for progress payments.
2. The final Application for Payment shall be accompanied (except as previously delivered) by:
  - a. all documentation called for in the Contract Documents, including but not limited to the evidence of insurance required by Paragraph 5.04.B.6;
  - b. consent of the surety, if any, to final payment;
  - c. a list of all Claims against Owner that Contractor believes are unsettled; and
  - d. complete and legally effective releases or waivers (satisfactory to Owner) of all Lien rights arising out of or Liens filed in connection with the Work.
3. In lieu of the releases or waivers of Liens specified in Paragraph 14.07.A.2 and as approved by Owner, Contractor may furnish receipts or releases in full and an affidavit of Contractor that: (i) the releases and receipts include all labor, services, material, and equipment for which a Lien could be filed; and (ii) all payrolls, material and equipment bills, and other indebtedness connected with the Work for which Owner might in any way be responsible, or which might in any way result in liens or other burdens on Owner's property, have been paid or otherwise satisfied. If any Subcontractor or Supplier fails to furnish such a release or receipt in full, Contractor may furnish a bond or other collateral satisfactory to Owner to indemnify Owner against any Lien.

##### B. *Engineer's Review of Application and Acceptance:*

1. If, on the basis of Engineer's observation of the Work during construction and final inspection, and Engineer's review of the final Application for Payment and accompanying

documentation as required by the Contract Documents, Engineer is satisfied that the Work has been completed and Contractor's other obligations under the Contract Documents have been fulfilled, Engineer will, within ten days after receipt of the final Application for Payment, indicate in writing Engineer's recommendation of payment and present the Application for Payment to Owner for payment. At the same time Engineer will also give written notice to Owner and Contractor that the Work is acceptable subject to the provisions of Paragraph 14.09. Otherwise, Engineer will return the Application for Payment to Contractor, indicating in writing the reasons for refusing to recommend final payment, in which case Contractor shall make the necessary corrections and resubmit the Application for Payment.

C. *Payment Becomes Due:*

1. Thirty days after the presentation to Owner of the Application for Payment and accompanying documentation, the amount recommended by Engineer, less any sum Owner is entitled to set off against Engineer's recommendation, including but not limited to liquidated damages, will become due and will be paid by Owner to Contractor.

14.08 *Final Completion Delayed*

- A. If, through no fault of Contractor, final completion of the Work is significantly delayed, and if Engineer so confirms, Owner shall, upon receipt of Contractor's final Application for Payment (for Work fully completed and accepted) and recommendation of Engineer, and without terminating the Contract, make payment of the balance due for that portion of the Work fully completed and accepted. If the remaining balance to be held by Owner for Work not fully completed or corrected is less than the retainage stipulated in the Agreement, and if bonds have been furnished as required in Paragraph 5.01, the written consent of the surety to the payment of the balance due for that portion of the Work fully completed and accepted shall be submitted by Contractor to Engineer with the Application for such payment. Such payment shall be made under the terms and conditions governing final payment, except that it shall not constitute a waiver of Claims.

14.09 *Waiver of Claims*

- A. The making and acceptance of final payment will constitute:
  1. a waiver of all Claims by Owner against Contractor, except Claims arising from unsettled Liens, from defective Work appearing after final inspection pursuant to Paragraph 14.06, from failure to comply with the Contract Documents or the terms of any special guarantees specified therein, or from Contractor's continuing obligations under the Contract Documents; and
  2. a waiver of all Claims by Contractor against Owner other than those previously made in accordance with the requirements herein and expressly acknowledged by Owner in writing as still unsettled.



## ARTICLE 15 – SUSPENSION OF WORK AND TERMINATION

### 15.01 *Owner May Suspend Work*

- A. At any time and without cause, Owner may suspend the Work or any portion thereof for a period of not more than 90 consecutive days by notice in writing to Contractor and Engineer which will fix the date on which Work will be resumed. Contractor shall resume the Work on the date so fixed. Contractor shall be granted an adjustment in the Contract Price or an extension of the Contract Times, or both, directly attributable to any such suspension if Contractor makes a Claim therefor as provided in Paragraph 10.05.

### 15.02 *Owner May Terminate for Cause*

- A. The occurrence of any one or more of the following events will justify termination for cause:
1. Contractor's persistent failure to perform the Work in accordance with the Contract Documents (including, but not limited to, failure to supply sufficient skilled workers or suitable materials or equipment or failure to adhere to the Progress Schedule established under Paragraph 2.07 as adjusted from time to time pursuant to Paragraph 6.04);
  2. Contractor's disregard of Laws or Regulations of any public body having jurisdiction;
  3. Contractor's repeated disregard of the authority of Engineer; or
  4. Contractor's violation in any substantial way of any provisions of the Contract Documents.
- B. If one or more of the events identified in Paragraph 15.02.A occur, Owner may, after giving Contractor (and surety) seven days written notice of its intent to terminate the services of Contractor:
1. exclude Contractor from the Site, and take possession of the Work and of all Contractor's tools, appliances, construction equipment, and machinery at the Site, and use the same to the full extent they could be used by Contractor (without liability to Contractor for trespass or conversion);
  2. incorporate in the Work all materials and equipment stored at the Site or for which Owner has paid Contractor but which are stored elsewhere; and
  3. complete the Work as Owner may deem expedient.
- C. If Owner proceeds as provided in Paragraph 15.02.B, Contractor shall not be entitled to receive any further payment until the Work is completed. If the unpaid balance of the Contract Price exceeds all claims, costs, losses, and damages (including but not limited to all fees and charges of engineers, architects, attorneys, and other professionals and all court or arbitration or other dispute resolution costs) sustained by Owner arising out of or relating to completing the Work, such excess will be paid to Contractor. If such claims, costs, losses, and damages exceed such unpaid balance, Contractor shall pay the difference to Owner. Such claims, costs, losses, and damages incurred by Owner will be reviewed by Engineer as to their reasonableness and, when

so approved by Engineer, incorporated in a Change Order. When exercising any rights or remedies under this Paragraph, Owner shall not be required to obtain the lowest price for the Work performed.

- D. Notwithstanding Paragraphs 15.02.B and 15.02.C, Contractor's services will not be terminated if Contractor begins within seven days of receipt of notice of intent to terminate to correct its failure to perform and proceeds diligently to cure such failure within no more than 30 days of receipt of said notice.
- E. Where Contractor's services have been so terminated by Owner, the termination will not affect any rights or remedies of Owner against Contractor then existing or which may thereafter accrue. Any retention or payment of moneys due Contractor by Owner will not release Contractor from liability.
- F. If and to the extent that Contractor has provided a performance bond under the provisions of Paragraph 5.01.A, the termination procedures of that bond shall supersede the provisions of Paragraphs 15.02.B and 15.02.C.

#### 15.03 *Owner May Terminate For Convenience*

- A. Upon seven days written notice to Contractor and Engineer, Owner may, without cause and without prejudice to any other right or remedy of Owner, terminate the Contract. In such case, Contractor shall be paid for (without duplication of any items):
  - 1. completed and acceptable Work executed in accordance with the Contract Documents prior to the effective date of termination, including fair and reasonable sums for overhead and profit on such Work;
  - 2. expenses sustained prior to the effective date of termination in performing services and furnishing labor, materials, or equipment as required by the Contract Documents in connection with uncompleted Work, plus fair and reasonable sums for overhead and profit on such expenses;
  - 3. all claims, costs, losses, and damages (including but not limited to all fees and charges of engineers, architects, attorneys, and other professionals and all court or arbitration or other dispute resolution costs) incurred in settlement of terminated contracts with Subcontractors, Suppliers, and others; and
  - 4. reasonable expenses directly attributable to termination.
- B. Contractor shall not be paid on account of loss of anticipated profits or revenue or other economic loss arising out of or resulting from such termination.

#### 15.04 *Contractor May Stop Work or Terminate*

- A. If, through no act or fault of Contractor, (i) the Work is suspended for more than 90 consecutive days by Owner or under an order of court or other public authority, or (ii) Engineer fails to act on any Application for Payment within 30 days after it is submitted, or (iii) Owner fails for 30 days

to pay Contractor any sum finally determined to be due, then Contractor may, upon seven days written notice to Owner and Engineer, and provided Owner or Engineer do not remedy such suspension or failure within that time, terminate the Contract and recover from Owner payment on the same terms as provided in Paragraph 15.03.

- B. In lieu of terminating the Contract and without prejudice to any other right or remedy, if Engineer has failed to act on an Application for Payment within 30 days after it is submitted, or Owner has failed for 30 days to pay Contractor any sum finally determined to be due, Contractor may, seven days after written notice to Owner and Engineer, stop the Work until payment is made of all such amounts due Contractor, including interest thereon. The provisions of this Paragraph 15.04 are not intended to preclude Contractor from making a Claim under Paragraph 10.05 for an adjustment in Contract Price or Contract Times or otherwise for expenses or damage directly attributable to Contractor's stopping the Work as permitted by this Paragraph.

## **ARTICLE 16 – DISPUTE RESOLUTION**

### *16.01 Methods and Procedures*

- A. Either Owner or Contractor may request mediation of any Claim submitted to Engineer for a decision under Paragraph 10.05 before such decision becomes final and binding. The mediation will be governed by the Construction Industry Mediation Rules of the American Arbitration Association in effect as of the Effective Date of the Agreement. The request for mediation shall be submitted in writing to the American Arbitration Association and the other party to the Contract. Timely submission of the request shall stay the effect of Paragraph 10.05.E.
- B. Owner and Contractor shall participate in the mediation process in good faith. The process shall be concluded within 60 days of filing of the request. The date of termination of the mediation shall be determined by application of the mediation rules referenced above.
- C. If the Claim is not resolved by mediation, Engineer's action under Paragraph 10.05.C or a denial pursuant to Paragraphs 10.05.C.3 or 10.05.D shall become final and binding 30 days after termination of the mediation unless, within that time period, Owner or Contractor:
  - 1. elects in writing to invoke any dispute resolution process provided for in the Supplementary Conditions; or
  - 2. agrees with the other party to submit the Claim to another dispute resolution process; or
  - 3. gives written notice to the other party of the intent to submit the Claim to a court of competent jurisdiction.

## **ARTICLE 17 – MISCELLANEOUS**

### *17.01 Giving Notice*

- A. Whenever any provision of the Contract Documents requires the giving of written notice, it will be deemed to have been validly given if:

1. delivered in person to the individual or to a member of the firm or to an officer of the corporation for whom it is intended; or
2. delivered at or sent by registered or certified mail, postage prepaid, to the last business address known to the giver of the notice.

17.02 *Computation of Times*

- A. When any period of time is referred to in the Contract Documents by days, it will be computed to exclude the first and include the last day of such period. If the last day of any such period falls on a Saturday or Sunday or on a day made a legal holiday by the law of the applicable jurisdiction, such day will be omitted from the computation.

17.03 *Cumulative Remedies*

- A. The duties and obligations imposed by these General Conditions and the rights and remedies available hereunder to the parties hereto are in addition to, and are not to be construed in any way as a limitation of, any rights and remedies available to any or all of them which are otherwise imposed or available by Laws or Regulations, by special warranty or guarantee, or by other provisions of the Contract Documents. The provisions of this Paragraph will be as effective as if repeated specifically in the Contract Documents in connection with each particular duty, obligation, right, and remedy to which they apply.

17.04 *Survival of Obligations*

- A. All representations, indemnifications, warranties, and guarantees made in, required by, or given in accordance with the Contract Documents, as well as all continuing obligations indicated in the Contract Documents, will survive final payment, completion, and acceptance of the Work or termination or completion of the Contract or termination of the services of Contractor.

17.05 *Controlling Law*

- A. This Contract is to be governed by the law of the state in which the Project is located.

17.06 *Headings*

- A. Article and paragraph headings are inserted for convenience only and do not constitute parts of these General Conditions.

Section 00800

SUPPLEMENTARY CONDITIONS

SCOPE. These Supplementary Conditions amend or supplement the Standard General Conditions of the Construction Contract (C-700, 2007 Edition) and other provisions of the Contract Documents as indicated herein. All provisions which are not so amended or supplemented remain in full force and effect.

SC-1. DEFINITIONS AND TERMINOLOGY.

SC-1.01. DEFINED TERMS. The terms used in these Supplementary Conditions which are defined in the Standard General Conditions of the Construction Contract (C-700, 2007 Edition) have the meanings assigned to them in the General Conditions.

Amend the terms as follows:

3. Application for Payment: Strike out the word "Engineer" and insert the word "Owner" in its place.
9. Change Order: Strike out the words "recommended by Engineer".
12. Contract Documents: In the first sentence, strike out the word "Engineer's" and insert the word "Owner's" in its place.
15. Contract Times: Strike out the words "as evidenced by Engineer's written recommendation of final payment".
16. Delete the term "Contractor" and substitute therefore the terms "Contractor or Prime Contractor."
17. Add the following sentence to the definition: "Drawings may also be described as Plans."
20. Field Order: Strike out the word "Engineer" and insert the word "Owner" in its place.
22. Delete the words " or Radioactive Material" and substitute therefore the words "Radioactive Material or other pollutants or contaminants".
44. Substantial Completion: Strike out the word "Engineer" and insert the word "Owner" in its place. Add the following to the first sentence: "and a Certificate of Substantial Completion has been completed."
51. Work Change Directive: In the first sentence strike out the words "and recommended by Engineer".

Additional terms used in these Supplementary Conditions have the meanings indicated herein, which are applicable to both the singular and plural thereof.

Add the following new definitions to paragraph 1.01:

- “52. Final Completion – The time when all work is complete, including all punch list items, and all documents required for occupancy of the facility are completed and submitted to the OWNER. These documents include, but are not limited to, Certificate of Occupancy, Letters of Approval from various regulatory agencies, inspection certificates, and all other items as required in paragraph 14.07.”
- “53. General Contractor – The person, firm, or corporation with whom OWNER has entered into an Agreement for a complete project, general trades, or complete project less a part of the project.”
- “54. Without exception – The term “without exception”, when used in the Contract Documents following the name of a Supplier or a proprietary item of equipment, product, or material, shall mean that the sources of the product are limited to the listed Suppliers or products and that no like, equivalent, or “or-equal” item and no substitution will be considered.”
- “55. Written Notice – Notice to any party which is in writing and which shall be considered delivered and the service thereof completed once posted by certified or registered mail to the party to whom the notice is sent at its last given address or delivered in person to said party or its authorized representative on the work.”

SC-102. TERMINOLOGY. Add the following paragraphs G, H, and I.

"G. Imperative Mood. These specifications are written to the BIDDER before the award of the Contract and to the CONTRACTOR after award of the Contract. The sentences that direct the CONTRACTOR to perform work are mostly written as commands. For example, a requirement to provide cold-weather protection would be expressed as, 'Provide cold-weather protection for concrete,' rather than 'The Contractor shall provide cold-weather protection for concrete.' In the imperative mood, the subject "the Bidder" or "the Contractor" is understood.

"H. Engineer Interpretations. In order to avoid cumbersome and confusing repetition of expressions in these specifications, it is provided that whenever anything is, or is to be, done, if, as, or, when, or where 'demonstrated, contemplated, required, determined, directed, specified, authorized, ordered, given, designated, indicated, considered necessary, deemed necessary, permitted, reserved, suspended, established, approval, approved, disapproved, acceptable, unacceptable, suitable, satisfactory, unsatisfactory, sufficient, insufficient, rejected, or condemned,' it shall be understood as if the expression were followed by the words 'by the Engineer' or 'to the Engineer.'

"I. 'Shown.' When this term is used in the specifications, it means 'shown on the Drawings' unless stated otherwise."

SC-2. PRELIMINARY MATTERS.

SC-2.02. Copies of Documents. Delete the second sentence of paragraph 2.02.A and insert the following new sentence in its place:

“Five (5) sets of contract drawings and specifications will be furnished the Contractor without charge. Additional sets will be furnished upon request at the cost of reproduction. The Contractor shall keep one (1) set of approved plans and specifications on the site of the work. This set shall be kept current by addition of all approved changes, addenda and amendments thereto. One set of as-built plans shall be returned to the Owner after the project is complete.

The plans and specifications are intended to be complementary; but should any discrepancy appear or any misunderstanding arise as to the import of anything contained in either, the decision of the Owner shall be final and binding on the Contractor. The Owner may make any corrections of errors or omissions in the drawings and specifications when such corrections are necessary for the proper fulfillment of their intention as construed by the Owner.

All work or materials shown on the plans and not mentioned in the specifications or any work specified and not shown on the plans, shall be furnished, performed and done by the Contractor as if the same were both mentioned in the specifications and shown on the plans.

Should the Contractor in preparing its bid find anything necessary for the construction of the project that is not mentioned in the specifications or shown on the plans, or any discrepancy, it shall notify the Owner so that such items may be included. Should the Contractor fail to notify the Owner of such items, it will be assumed that its bid included everything necessary for the complete construction in the spirit and intent of the designs shown.

In case of discrepancy, figure dimensions shall govern over scale dimensions, large-scale details shall govern over small-scale drawings, plans shall govern over specifications, detailed technical specifications shall govern over general specifications, and the more restrictive specifications shall prevail.”

SC-2.03. Commencement of Contract Times; Notice to Proceed. Delete the paragraph and insert in its place:

"A. The Contract Times will commence to run on the day indicated in the Notice to Proceed. The date for the Contract Times may be extended by mutual agreement between the OWNER and the CONTRACTOR."

SC-3. CONTRACT DOCUMENTS: INTENT, AMENDING, REUSE. No modifications.

SC-4. AVAILABILITY OF LANDS; SUBSURFACE AND PHYSICAL CONDITIONS; REFERENCE POINTS.

SC-4.02. Subsurface and Physical Conditions. Replace paragraph 4.02 with the following:

"A. Reports and Drawings:

"1. In preparation of the Contract Documents, the following reports of explorations and tests of conditions at the Ohio River Pumping Station No. 2 were used: ORPS2 Condition Assessment/MPTP Raw Water Supply Feasibility Study by HDR, dated March 13, 2015; Various Structural Investigation Drawings by Thelen, dated October 23, 2013; Petrographic Concrete Testing by Concrete Research Testing, dated October 3, 2013; Underwater Inspection Report by Marine Solutions Inc., dated October 7, 2013; Lead Sampling Report by Horizon QC, dated November 12, 2013; Asbestos Sampling and Report by Larkin Environmental Solutions, dated September 15, 2013; Underwater Inspection Report by Terracon Consultants, performed March 31, 2016, dated April 11, 2016. Those reports of explorations and tests of conditions at the Site which ENGINEER has used in preparing the Contract Documents are not Contract Documents and are to be considered 'technical data.'

"2. CONTRACTOR may not rely upon or make any claim against OWNER or ENGINEER with respect to:

"a. The completeness of such reports and drawings for CONTRACTOR's purposes, including, but not limited to, any aspects of the means, methods, techniques, sequences, and procedures of construction to be employed by CONTRACTOR, and safety precautions and programs incident thereto; or

"b. Other data, interpretations, opinions, and information contained in such reports or shown or indicated in such drawings; or

"c. Any CONTRACTOR interpretation of or conclusion drawn from any 'technical data' or any such other data, interpretations, opinions, or information.

#### SC-4.03. Differing Subsurface or Physical Conditions.

Replace paragraph 4.03.A with the following:

"A. Notice: If CONTRACTOR believes that any subsurface or physical condition at or contiguous to the Site that is uncovered or revealed either:

"1. Is of such nature as to require a change in the Contract Documents; or

"2. Differs materially from that shown or indicated in the Contract Documents; or

"3. Is of an unusual nature, and differs materially from conditions ordinarily encountered and generally recognized as inherent on work of the character provided for in the Contract Documents;



"then CONTRACTOR shall, promptly after becoming aware thereof and before further disturbing the subsurface or physical conditions or performing any work in connection therewith (except in an emergency as required by paragraph 6.16.A), notify OWNER and ENGINEER in writing about such condition. CONTRACTOR shall not further disturb such condition or perform any work in connection therewith (except as aforesaid) until receipt of written order to do so."

#### SC-4.04. Underground Facilities.

Add the following immediately after paragraph 4.04.A.2.

##### "4.04.A.3 Location of Subsurface Utilities.

"a. The location of subsurface utilities is shown on the plans from information furnished by the utility owners.

"b. The CONTRACTOR shall, no later than 2 working days, excluding Saturdays, Sundays, and legal holidays, prior to construction in the area of the subsurface utility, notify the subsurface utility Owner in writing, by telephone, or in person. The marking or locating shall be coordinated to stay approximately 2 days ahead of the planned construction.

"c. The CONTRACTOR shall alert immediately the occupants of nearby premises as to any emergency that it may create or discover at or near such premises.

"d. The CONTRACTOR shall have full responsibility for coordination of the work with owners of such underground facilities during construction, for the safety and protection thereof as provided in paragraph 6.13 and repairing any damage thereto resulting from the work, the cost of all of which will be considered as having been included in the Contract Price.

"4.04.A.4 Where existing utilities and structures are indicated as being in the line of the proposed improvement, the CONTRACTOR shall expose them sufficiently in advance of the construction operations to permit adjustments in line or grade, if required, to eliminate interferences.

"4.04.A.5 Existing pipes or conduits crossing a trench, or otherwise exposed, shall be adequately braced and supported to prevent movement during construction.

##### "4.04.A.6 Broken Utility Services.

"a. Utility services broken or damaged shall be repaired at once to avoid inconvenience to customers and utility owners.

"b. Temporary arrangements, as approved by the ENGINEER, may be used until any damaged items can be permanently repaired.

"c. All items damaged or destroyed by construction and subsequently repaired must be properly maintained by the CONTRACTOR.

"d. CONTRACTOR must work 24 hours a day until service is restored to a damaged utility.

"4.04.A.7 Existing Utility Relocation.

"a. Where it is necessary to relocate an existing utility or structure, the work shall be done in such manner as is necessary to restore it to a condition equal to that of the original utility or structure.

"b. No such relocation shall be done until approval is received from the authority responsible for the utility or structure being changed."

SC-4.06 Hazardous Environmental Conditions at Site.

Delete paragraph 4.06.A. in its entirety and substitute the following paragraph therefore:

A. The following reports and drawings related to Hazardous Environmental Conditions identified at the Site are known to Owner: Lead Sampling Report by Horizon QC, dated November 12, 2013; Asbestos Sampling and Report by Larkin Environmental Solutions, dated September 15, 2013.

Amend paragraph 4.06.B by adding the words "that is created by, or" immediately after the words "a Hazardous Environmental Condition" in the fourth line.

Amend paragraph 4.06.G by deleting all words following the words "Hazardous Environmental Condition" in the seventh line and substituting therefore the following words: "was created by Owner or by anyone for whom Owner is responsible, other than Contractor and all persons, subcontractors and entities for which Contractor is responsible."

SC-5. BONDS AND INSURANCE.

SC-5.02. Licensed Sureties and Insurers. Add the following new sentence at the end of paragraph 5.02.A:

The surety company shall be rated "A" by AM BEST.

SC-5.03. Certificates of Insurance. Add the following new sentence at the end of paragraph 5.03.A:

Contractor shall deliver to Owner properly completed certificates of insurance prior to the start of any Work at the Site, on the forms included in the Contract Documents.

SC-5.04. Contractor's Insurance.

Add the following new paragraphs immediately after paragraph 5.04.A.6:

7. Claims arising out of pollution and excluded from the Contractor's general liability and comprehensive automobile liability policies. This insurance shall

be coordinated with the Contractor's general liability policy and shall provide bodily injury and property damage coverage similar to the Contractor's general liability policy. Coverage shall include contractual liability.

Add the following new paragraphs immediately after paragraph 5.04.B.6:

7. contain a cross liability or severability of interest clause or endorsement. Insurance covering the specified additional insureds shall be primary insurance, and all other insurance carried by the additional insureds shall be excess insurance;
8. with respect to workers' compensation and employers' liability, comprehensive automobile liability, commercial general liability, and umbrella liability insurance, and all other liability insurance specified herein to be provided by Contractor, Contractor shall require its insurance carriers to waive all rights of subrogation against Owner, Engineer, and their respective officers, directors, partners, employees, and agents.

Add the following new paragraphs immediately after paragraph 5.04.B:

- C. The insurance required by paragraph 5.04 shall include coverage as necessary for the benefits provided under the United States Longshoremen's and Harbor Workers' Act and the Jones Act. This policy shall include an "all states" endorsement.
- D. The limits of liability for the insurance required by paragraph 5.04 of the General Conditions shall provide coverage for not less than the following amounts but shall provide coverage in greater amounts where required by Laws and Regulations. This coverage may be primary or a combination of primary and umbrella excess liability.
  1. Workers' Compensation, and related coverage under paragraphs 5.04.A.1 and 5.04.A.2 of the General Conditions:
    - a. State Statutory
    - b. Applicable Federal (e.g., Longshoreman's) Statutory
    - b. Employer's Liability \$1,000,000 each occurrence
  2. Commercial General Liability under paragraphs 5.04.A.3 through 5.04.A.6 of the General Conditions shall be occurrence type, written in comprehensive form, and shall protect Contractor, Owner, and Engineer as additional insureds, against claims arising from injuries, sickness, disease, or death of any person or damage to property arising out of performance of the Work. The policy shall also include a per project aggregate limit endorsement, personal injury liability coverage, contractual liability coverage for blasting, explosion, collapse of buildings, and damage to underground property.
    - a. General Aggregate \$1,000,000

- b. Products – Completed Operations Aggregate \$1,000,000
  - c. Personal and Advertising Injury \$1,000,000
  - d. Each Occurrence (Bodily Injury and Property Damage) \$1,000,000
  - e. Property Damage liability insurance will provide Explosion, Collapse and Underground coverage's where applicable.
3. Automobile Liability under paragraph 5.04.A.6 of the General Conditions shall be occurrence type, written in comprehensive form, and shall protect Contractor, Owner, and Engineer as additional insureds, against all claims for injuries to members of the public and damage to property of others arising from the use of motor vehicles, either on or off the project site whether they are owned, nonowned, or hired. The liability limit shall be not less than:
- a. Bodily Injury
    - Each Person \$1,000,000
    - Each Accident \$1,000,000
  - b. Property Damage
    - Each Accident \$1,000,000
  - c. Combined Single Limit \$1,000,000
4. Umbrella Liability Insurance shall protect Contractor, Owner, and Engineer as additional insureds, against claims in excess of the limits provided under workers' compensation and employers' liability, comprehensive automobile liability, and commercial general liability policies. The umbrella policy shall follow the forms of the primary insurance, including the application of the primary limits. The liability limits shall be not less than:
- Bodily injury and Property damage \$4,000,000 combined single limit for each occurrence
  - \$4,000,000 general aggregate

SC-5.05. Owner's Liability Insurance. Delete paragraph 5.05 in its entirety and insert the following new paragraph in its place:

5.05. *Owner's Liability Insurance*. This insurance shall be obtained by Contractor and issued in the name of Owner, and shall protect and defend Owner against claims arising as a result of the operations of Contractor or Contractor's Subcontractors. The liability limits shall be not less than:

- a. Bodily Injury

Each Occurrence	\$1,000,000
General Aggregate	\$1,000,000
b. Property Damage	
Each Occurrence	\$1,000,000
General Aggregate	\$1,000,000

SC-5.06. Property Insurance. Delete paragraph 5.06 in its entirety and insert the following new paragraphs in their place:

5.06. *Property Insurance*

A. Contractor shall purchase and maintain property insurance coverage upon the Work at the Site in the amount of the full replacement cost thereof. This insurance shall:

1. include the interests of Owner, Contractor, Subcontractors, Engineer, Engineer's Consultants, and any other individuals or entities identified in the Supplementary Conditions, and the officers, directors, partners, employees, agents, and other consultants and subcontractors of each and any of them, each of whom is deemed to have an insurable interest and shall be listed as an additional insured;
2. be written on a Builder's Risk "all-risk" or open peril or special causes of loss policy form that shall at least include insurance for physical loss or damage to the Work, temporary buildings, false work, and materials and equipment, and shall insure against at least the following perils or causes of loss: fire, lightning, extended coverage, theft, vandalism and malicious mischief, earthquake, collapse, debris removal, demolition occasioned by enforcement of Laws and Regulations, water damage, flood, damage caused by frost and freezing, and such other perils or causes of loss as may be specifically required by the Supplementary Conditions;
3. cover materials and equipment stored at the Site or at another location that was agreed to in writing by Owner prior to being incorporated in the Work, provided that such materials and equipment have been included in an Application for Payment accepted by Owner;
4. include expenses incurred in the repair or replacement of any insured property (including, but not limited to, fees and charges of engineers and architects);
5. allow for partial utilization of the Work by Owner;
6. include testing and startup; and
7. be maintained in effect until final payment is made unless otherwise agreed to in writing by Owner, Contractor, and Engineer, with 30 days' written notice to each other additional insured to whom a certificate of insurance has been issued.

B. Contractor shall be responsible for any deductible or self-insured retention.

C. All the policies of insurance (and the certificates or other evidence thereof) required to be purchased and maintained in accordance with paragraph 5.06 shall contain a provision or endorsement that the coverage afforded will not be canceled or materially changed or renewal refused until at least 30 days prior written notice has been given to Owner and Contractor and to each other additional insured to whom a certificate of insurance has been issued and will contain waiver provisions in accordance with paragraph 5.07.

D. If Owner requests in writing that other special insurance be included in the property insurance policies provided under paragraph 5.06, Contractor shall, if possible, include such insurance, and the cost thereof will be charged to Owner by appropriate Change Order or Written Amendment. Prior to commencement of the Work at the Site, Contractor shall in writing advise Owner whether or not Contractor has procured such other special insurance.

SC-6. CONTRACTOR'S RESPONSIBILITIES.

SC-6.02. Labor; Working Hours. Add the following new paragraphs immediately after paragraph 6.02.B:

C. No Work shall be done between 6:00 p.m. and 7:00 a.m. without permission of Owner. However, emergency work may be done without prior permission.

D. Night Work may be undertaken as a regular procedure with the permission of Owner; such permission, however, may be revoked at any time by Owner if Contractor fails to maintain adequate equipment and supervision for the proper prosecution and control of the Work at night.

SC-6.05. Substitutes and "Or-Equals". Add the following new paragraph after paragraph 6.05.A.2.d:

e. "If a proposed substitute item is accepted, all incidental costs associated with the use of the substitute including, but not limited to, redesign, claims of other Contractors, changes to electrical supply equipment, additional equipment or material required for the installation, etc., shall be at the expense of the Contractor proposing the substitute unless otherwise agreed to by the Owner."

SC-6.06. Concerning Subcontractors, Suppliers, and Others. Delete paragraph 6.06.B in its entirety and insert the following new paragraph in its place:

B. Contractor must identify to Owner the following Subcontractors, Suppliers, or other individuals or entities for acceptance by Owner by the date indicated: (Fill in or write Not applicable). \_\_\_\_\_

Date: \_\_\_\_\_, If Contractor has submitted a list thereof in accordance with these Supplementary Conditions, Owner's acceptance (either in writing or by failing to make written objection thereto by the date indicated for acceptance or objection in the Bidding Documents or the Contract Documents) of any such

Subcontractor, Supplier, or other individual or entity so identified may be revoked on the basis of reasonable objection after due investigation. Contractor shall submit an acceptable replacement for the rejected Subcontractor, Supplier, or other individual or entity without an increase in the Contract Price. No acceptance by Owner of any such Subcontractor, Supplier, or other individual or entity, whether initially or as a replacement, shall constitute a waiver of any right of Owner or Engineer to reject defective Work.

SC-6.08. Permits. Add the following new paragraph immediately after paragraph 6.08.A:

- B. Owner will obtain and pay for the following permits: Road & Highway Encroachment Permits, Kentucky Division of Water, and Stream Crossing Permits.

SC-6.09. Laws and Regulations. Add the following new paragraph immediately after paragraph 6.09.C:

- D. Employment requirements shall be as specified herein and in the attachments at the end of the Supplementary Conditions.

SC-6.10. Taxes. Add the following new paragraph immediately after Paragraph 6.10.A of the General Conditions:

- B. Portions of this project may be exempt from taxes. It is the Contractor's responsibility to determine any applicable exemptions.

SC-6.19. Contractor's General Warranty and Guarantee. Delete paragraph 6.19.C.7 and substitute the following new paragraph therefore:

- 7. any correction of defective Work by Owner; or

Add the following new paragraph immediately after paragraph 6.19.C.7:

- 8. any expiration of a correction period.

SC-7. OTHER WORK. No modifications.

SC-8. OWNER'S RESPONSIBILITIES. No modifications.

SC-9. ENGINEER'S STATUS DURING CONSTRUCTION.

SC-9.02. Visits to Site. Delete paragraph 9.02.A in its entirety and insert the following new paragraph in its place:

- A. Engineer may make visits to the Site as Owner deems necessary in order to observe as an experienced and qualified design professional the progress that has been made and the quality of the various aspects of Contractor's executed Work. Based on information obtained during such visits and observations, Engineer, at the request and benefit of Owner, may determine, in general, if the Work is proceeding in accordance with the Contract Documents. Engineer will not be required to make exhaustive or continuous inspections on the Site to check the quality or quantity of the Work.

Engineer's efforts will be directed toward providing for Owner a greater degree of confidence that the completed Work will conform generally to the Contract Documents. On the basis of such visits and observations, Engineer will advise Owner of the progress of the Work and will endeavor to guard Owner against defective Work.

SC-10. CHANGES IN THE WORK. No Modifications.

SC-11. COST OF THE WORK; CASH ALLOWANCES; UNIT PRICE WORK. No modifications.

SC-12. CHANGE OF CONTRACT PRICE; CHANGE OF CONTRACT TIMES.

SC-12.03. Delays Beyond Contractor's Control. Insert the following new paragraph 12.03.F immediately after paragraph 12.03.E:

F. In no event shall Owner or Engineer be liable to Contractor, any Subcontractor, any Supplier, or any other person or organization, or to any surety for or employee or agent of any of them, for damages (including acceleration costs) arising out of or resulting from any delay.

SC-12.04. Delay Damages. Add the following new paragraph after paragraph 12.03.

A. Except as set forth in paragraph 3.3 of the Agreement, in no event shall Owner or Engineer be liable to Contractor, any Subcontractor, any Supplier, or any other person or organization, or to any surety for or employee or agent of any of them, for damages (including acceleration costs) arising out of or resulting from any delay.

SC-13. TESTS AND INSPECTIONS; CORRECTION, REMOVAL, OR ACCEPTANCE OF DEFECTIVE WORK.

SC-13.02. Access to Work. Add the following new paragraph immediately after paragraph 13.02.A:

B. Authorized representatives of the U.S. Environmental Protection Agency and the Kentucky Division of Water shall have access to the Work whenever it is in preparation or progress. Contractor shall provide proper facilities for such access and inspection.

SC-13.07. Correction Period. Add the following new paragraph after paragraph 13.07.E:

F. Nothing in Article 13 concerning the correction period shall establish a period of limitation with respect to any other obligation which Contractor has under the Contract Documents. The establishment of time periods relates only to the specific obligations of Contractor to correct the Work, and has no relationship to the time within which Contractor's obligations under the Contract Documents may be sought to be enforced, nor to the time within which proceedings may be commenced to establish Contractor's liability with respect to Contractor's obligations other than to specifically correct the Work.

SC-14. PAYMENTS TO CONTRACTOR AND COMPLETION.



SC-14.02. Applications for Payments. Add the following new paragraphs immediately after paragraph 14.02.A.3:

4. Contractor's Applications for Payment shall be accompanied by the documentation specified herein.
5. Payments for stored materials and equipment shall be based only upon the actual cost to Contractor of the materials and equipment and shall not include any overhead or profit to Contractor. Partial payments will not be made for undelivered materials or equipment.
6. During the progress of the Work, each Application for Payment shall be accompanied by Contractor's updated schedule of operations, or progress report, with such shop drawings schedules, procurement schedules, value of material on hand included in application, and other data specified in Contract Documents or reasonably required by Owner.

Delete paragraphs 14.02.C in its entirety and insert the following new paragraphs in its place:

*C. Payment Becomes Due*

1. Twenty-five days after presentation of the Application for Payment to Owner with Engineer's recommendation, the amount recommended will (subject to the provisions of paragraph 14.02.D) become due, and when due will be paid by Owner to Contractor.

SC-14.04. Substantial Completion. Add the following new paragraphs following paragraph 14.04.A:

To be considered substantially complete, the following portions of the Work must be operational and ready for Owner's continuous use as intended: operation room floor must be complete; trash rack, sluice gate and inlet valve must be installed; new windows must be installed; foundation repairs must be complete; potassium permanganate containment area must be complete within operations room and the storage tank placed within; wet well lighting must be installed; ventilation improvements must be complete; new wood stud wall must be complete; and work within the wet well must be complete.

Portions of the Work not essential to operation, which can be completed without interruption of the Owner's operation, may be completed after the Work is accepted as substantially complete, and may include the following items: final window trim, painting.

SC-14.07. Final Application for Payment. Add the following new sentence immediately after the last sentence of paragraph 14.07.A.2.b.:

Consent of the surety, signed by an agent, must be accompanied by a certified copy of such agent's authority to act for the surety. The Contractor shall be responsible for providing all of the documents identified in this paragraph.

SC-15. SUSPENSION OF WORK AND TERMINATION.

SC-15.01 Owner may suspend Work. Delete the word “shall” in the fifth line of paragraph 15.01.A and substitute the word “may” therefore.

SC-16. DISPUTE RESOLUTION.

Delete Article 16 in its entirety and insert the following new article in its place:

ARTICLE 16 - DISPUTES.

Arbitration will not be acceptable as a means for settling claims, disputes, and other matters.

SC-17. MISCELLANEOUS.

SC-17.04. Survival of Obligations. Add the following new paragraph immediately after paragraph 17.04.A:

B. Contractor shall obtain from all Suppliers and manufacturers any and all warranties and guarantees of such Suppliers and manufacturers, whether or not specifically required by the Specifications, and shall assign such warranties and guarantees to Owner. With respect thereto, Contractor shall render reasonable assistance to Owner when requested, in order to enable Owner to enforce such warranties and guarantees. The assignment of any warranties or guarantees shall not affect the Correction Period or any other provisions of these Contract Documents.

End of Section

**DIVISION 01**  
**GENERAL REQUIREMENTS**

**THIS PAGE LEFT BLANK INTENTIONALLY**

**SECTION 01030  
PROJECT DATES**

**PART 1 GENERAL**

1.1 DESCRIPTION

- A. The CONTRACTOR shall provide services, as described in these Specifications in accordance with the schedule for the installation work:
1. Deliverable(s)
    - a. Detailed Project Schedule – Initial Submittal – 30 calendar days from award of contract.
    - b. Detailed Project Schedule – Final Version – 30 calendar days from receipt of comments from OWNER and ENGINEER.
    - c. Schedule of Values – 30 calendar days from award of contract.
  2. Substantial Completion
    - a. Completion of all Work described in Section 01 11 00 within 365 calendar days from notice to proceed.
  3. Milestone(s)
    - a. Milestone I – Completion of the trash rack, sluice gate, suction inlet valve, and floor slab replacement by no later than May 1, 2017. Based on a notice to proceed on or about November 1, 2016.
  4. Final Acceptance
    - a. All remaining completion items (i.e. Punchlist) shall be completed to the OWNER'S satisfaction within 395 calendar days from notice to proceed.

**PART 2 PRODUCTS**

NOT USED

**PART 3 EXECUTION**

NOT USED

END OF SECTION

**PROJECT DATES**

THIS PAGE LEFT BLANK INTENTIONALLY

**SECTION 01 11 00  
SUMMARY OF WORK**

**PART1    GENERAL**

1.1    REQUIREMENTS INCLUDED

- A.    The work to be performed under this Contract shall consist of furnishing all tools, equipment, materials, supplies, and furnishing all transportation and services, including fuel, power, water, and essential communications, and performance of all labor, work or other operations required for the fulfillment of the Contract in strict accordance with the specifications, schedules, drawings, and other Contract Documents as herein defined, all which are made a part hereof, and including such detail drawings as may be furnished by ENGINEER from time to time during construction in clarification of said Contract Documents. Work shall be completed and all work, materials, and services not expressly shown or called for in Contract Documents which may be necessary for the complete and proper construction of the work in good faith shall be performed, furnished, and installed by CONTRACTOR as though originally so specified or shown, at no increase in cost to OWNER.

1.2    WORK COVERED BY CONTRACT DOCUMENTS

- A.    The Northern Kentucky Water District (NKWD) owns, operates and maintains a 16.6 million gallon per day (MGD) raw water pump station located in Fort Thomas, Kentucky. The pump station draws water from the Ohio River for delivery to the Memorial Parkway Treatment Plant for eventual distribution to NKWD customers. The Work described in the Contract Documents is generally described as follows:
  - 1.    General Construction: Work included in this contract will include but not necessarily be limited to select demolition of existing windows, loose mortar, broken/damaged foundation block, concrete structures, mechanical equipment, piping and various appurtenances; installation of a new concrete floor with appropriate appurtenances; installation of a new trash rack, influent sluice gate, and inlet suction valve; repair of foundation mortar and block; installation of 16 semi-circular and rectangular windows; installation of new FRP ladders and platforms; installation of a new motor operated damper and louver with controls; new lighting and miscellaneous electrical; and painting and other activities for a complete and operable project.

1.3    CONTRACT METHOD

- A.    Work hereunder will be constructed under one LUMP SUM contract as described above and as described in more detail in the Contract Documents.
- B.    All conditions in the Contract Documents shall apply to any and all subcontractors on this project. It shall be the Contractors responsibility to coordinate the Work with their respective subcontractors.

1.4    JURISDICTION

- A.    Agencies having jurisdiction over construction of this project include but are not

## SUMMARY OF WORK

limited to:

1. The United States Environmental Protection Agency (USEPA),
  2. The United States Army Corps of Engineers (Corps),
  3. The Kentucky Transportation Cabinet (KTC),
  4. The Kentucky Heritage Council (KHC),
  5. The Kentucky Division of Water (KDOW),
  6. The Kentucky Department of Housing, Buildings and Construction (KDHBC),
  7. CSX Railroad, and
  8. The City of Fort Thomas (FT).
- B. CONTRACTOR shall secure any permits associated with construction as required by the agency(s) having jurisdiction, shall abide by all rules and regulations of each and shall pay all costs in connection with the permits. CONTRACTOR shall pay for such permits and inspection fees to ensure compliance with their requirements.
- C. OWNER is pursuing permits from various regulatory agencies, which are included in Appendix C. The CONTRACTOR shall be responsible for complying with the terms and conditions of the permits. The following permits will be transferred to the CONTRACTOR following award of contract:
1. Corps Nationwide 3 Permit
  2. KDHBC Building Permit

### 1.5 NOTICES

- A. CONTRACTOR's are required to comply with the Kentucky 811 requirements prior to digging, even though direct excavation of utilities is not anticipated under this contract.
- B. CONTRACTOR shall be responsible to coordinate with the various utility companies the construction methods and work to be done in the vicinity of utilities. When temporary relocation is necessary sufficient advance notice shall be given by CONTRACTOR to the utility involved.

### 1.6 COORDINATION

- A. It shall be responsibility of CONTRACTOR to coordinate his operations and those of his subcontractors in such a manner so as to avoid interference or delays and ensure the orderly progress of Work in the areas of common or interdependent construction activities. Limits of the Contract are indicated on the Plans and specified herein. However, these limits may be altered by mutual agreement of CONTRACTOR with the OWNER, with the written Agreement of OWNER'S REPRESENTATIVE, in order to facilitate the work operations.
- B. The work of this Contract may involve coordination with other utility companies or agencies, either performing connection, repair or maintenance service on their own facilities. CONTRACTOR shall coordinate and cooperate with all utility companies and other contractors working in the same area that this Contract entails. This may



## SUMMARY OF WORK

include, but not be limited to, the telephone company; the electric power company; the gas company; all subcontractors; and any other contractors who are performing work within the area of this Contract.

- C. All work at the pumping station is to be coordinated with the Operations Manager and Operations staff. It is mandatory that the plant remain in full operation at all times. The pumps can be taken off line for certain periods of time, at certain times of the year. CONTRACTOR shall notify OWNER and ENGINEER at least seven (7) days in advance of any necessary interruption or shutdown. The OWNER maintains responsibility for all existing facility components not included in the scope of the project, and as such, the OWNER will perform operation and maintenance of these components. The CONTRACTOR will provide access to the OWNER at all times throughout the construction to allow the OWNER to operate and maintain the equipment.
- D. From May 1<sup>st</sup> through October 31<sup>st</sup>, the ORPS2 must be in service to meet customer demand. CONTRACTOR may be allowed minor shut downs during this period of the year. Minor shut downs would be considered less than 8 hours, during normal business hours, with the facility back at full capacity following the shutdown. From November 1<sup>st</sup> through April 30<sup>th</sup>, the ORPS2 may be shut down for longer periods of time to allow the CONTRACTOR to complete the work. The Owner is prepared to shutdown the facility for a period of three months beginning on January 1<sup>st</sup> through March 31<sup>st</sup>, at which time the facility will be ready for regular service operation.
- E. The existing CSX railroad crossing at the property is marked, but there are no warning lights. The CONTRACTOR will coordinate with CSX regarding train schedules and material deliveries.
- F. The existing potassium permanganate feed system will be dismantled by the OWNER, but the CONTRACTOR will relocate items as noted. The potassium permanganate feed system must be in place and operable when the pumping station is operating.
- G. The CONTRACTOR is responsible for all materials equipment installed under this contract until fully accepted by the OWNER. As the pumping station will be in use during the contract duration, some components may be operational and used by the OWNER prior to final acceptance.

### 1.7 REFERENCE STANDARDS

- A. Reference to the standards of any technical society, organization, or association or to codes of local, state or federal authorities shall mean the latest effective standard, code, specification, or standard adopted and published at the date of receipt of bids, unless specifically stated otherwise.

### 1.8 AVAILABILITY OF LAND

- A. All Work is located within the property lines of the OWNER at the existing pumping

## SUMMARY OF WORK

station.

- B. Nothing in this Contract shall imply that CONTRACTOR has exclusive use of roadways or public and/or private land employed to perform the work.
- C. CONTRACTOR shall coordinate staging, layout and equipment storage areas with OWNER and subcontractors on site. CONTRACTOR shall be responsible for the complete restoration of areas used by CONTRACTOR for such purposes, the cost of which is to be included in the Lump Sum price for this Project. CONTRACTOR is responsible for securing the staging and storage areas and limiting the ability for persons to access the pump station site through the staging and storage area. CONTRACTOR shall coordinate with OWNER to allow reasonable access by OWNER to the staging and storage area to perform routine activities associated with the facility operation.

### 1.9 SALVAGE OF MATERIAL AND EQUIPMENT

- A. No items shall be salvaged and reused without permission from OWNER or OWNER'S REPRESENTATIVE unless specifically stated otherwise in the bidding documents.
- B. OWNER reserves the right of first refusal to salvage any item from the pump station. If so directed by OWNER'S REPRESENTATIVE, CONTRACTOR shall deliver to a location on the pump station site any items to be salvaged by OWNER.

### 1.10 STORAGE OF MATERIALS

- A. Storage conditions shall be acceptable to OWNER for all materials and equipment not incorporated into the Work but included in applications for payment. Such storage arrangements and conditions shall be presented in writing and shall afford adequate and satisfactory security and protection. Off-site storage facilities shall be accessible to OWNER and OWNER'S REPRESENTATIVE. Stored materials shall be insured for full value. Certificates of Insurance coverage must be submitted to OWNER or OWNER'S REPRESENTATIVE with the request for payment by the CONTRACTOR.
- B. All arrangements and costs for storage facilities shall be paid by CONTRACTOR.

### 1.11 SUGGESTED CONSTRUCTION SEQUENCE

- A. The Contract Documents include a suggested construction sequence to be used as a guideline during the performance of the Work. Refer to Specification 01 1120 Suggested Sequence of Construction.

The intent of the suggested construction sequence is to maintain the pump station in adequate operation to discharge raw water to meet current demands during the course of the Work.

## SUMMARY OF WORK

- B. After Contract award, CONTRACTOR shall submit a construction sequencing plan for the Improvements that are part of his/her Contract. The sequencing plan may follow the plan suggested in the Contract Documents or could be a variation of that plan. CONTRACTOR is ultimately responsible for its own means, methods and materials in the completion of the Contract. CONTRACTOR sequencing plan is to be submitted to ENGINEER for review in accordance with the requirement of Section 01 3300 of these Specifications. Approval of the sequencing plan does not relieve CONTRACTOR from its responsibility to perform the Work in accordance with the Contract Documents and to allow the OWNER to maintain and operate the treatment facility at all times.
- C. CONTRACTOR shall achieve all Milestones as set forth in Specification Section 01 10 30 Project Dates, including Substantial Completion, and Final Completion in accordance with the dates set forth in the Contract Documents. CONTRACTOR understands that TIME IS OF THE ESSENCE of this Contract.
- D. OWNER delegates all scheduling and coordination responsibility for the work of the Project to CONTRACTOR. CONTRACTOR shall be responsible for scheduling and coordinating CONTRACTOR'S Work with the work of all other Contractors, Subcontractors, Equipment Suppliers, etc. and with OWNER'S forces on the Project.
- E. CONTRACTOR'S Schedule. Within 30 days of the Notice of Award, CONTRACTOR shall provide to Engineer and OWNER for their review, comment and approval a CPM schedule providing for all activities necessary for the completion of CONTRACTOR'S Work within the time limits set forth in the Contract Documents. All CPM Schedules submitted shall provide for the Completion of CONTRACTOR'S work in accordance with the Milestone Dates, the Substantial Completion Date, and the Final Completion Date, unless such dates are modified in a written Change Order signed by OWNER.
- F. CONTRACTOR shall be responsible for coordinating the Schedule, and to the extent appropriate, the OWNER'S own forces, into an overall Project Schedule which shall provide for the completion of all Project Work in accordance with the Milestone Dates, the Substantial Completion Date, and the Final Completion Date. In connection therewith, CONTRACTOR shall organize and conduct at least one schedule coordination meeting between and among CONTRACTOR, OWNER, and ENGINEER to obtain the agreement of all parties to the overall Project Schedule. All parties shall reach agreement and sign off on the overall Project Schedule. When agreed to by all parties, the Project Schedule shall become the baseline schedule for the Project.
- G. No later than the 10th day of each month, CONTRACTOR shall submit to the ENGINEER and OWNER a schedule report containing the updated Project Schedule, and a narrative report describing the basis and extent of any changes to the Project Schedule from the prior version of the Project Schedule, and describing in detail and changes or issues which may have an effect on the ability to complete the Project or the Work of any CONTRACTOR within the time required by the Contract Documents.

## **SUMMARY OF WORK**

- H. All CPM schedules and updates shall be submitted as both paper copies and in electronic native format, or as requested by OWNER or ENGINEER.

**PART2   PRODUCTS (NOT USED)**

**PART3   EXECUTION (NOT USED)**

END OF SECTION

**SECTION 01 1120  
SUGGESTED SEQUENCE OF CONSTRUCTION**

**PART 1   GENERAL**

1.1   DESCRIPTION

- A.   It is the CONTRACTOR'S responsibility to clean all channels, conduits or structures and remove and dispose of any debris, sediment, solids, etc. as necessary to proceed with the work, within the existing pumping station facilities in accordance with all applicable regulations. In planning and executing his program for construction, the CONTRACTOR shall note that no less than two (2) raw water pumps shall be operational at all times, unless an outage is specifically planned and discussed with the OWNER. The CONTRACTOR shall discuss, coordinate and agree with the OWNER.
  
- B.   The CONTRACTOR shall field verify the locations and elevations of all existing piping prior to any piping submittals.
  
- C.   All temporary electrical and piping materials, supports and routings shall be submitted for approval prior to installation.
  
- D.   Interruptions in facility operations shall be coordinated in accordance with 01 35233 Job Conditions, 01 5000 Temporary Facilities and Controls, and other contract documents.

1.2   SEQUENCE

- A.   The suggested sequence of construction includes:
  - 1.   CONTRACTOR to prepare the laydown and staging area identified on the drawings, including securing existing fence openings/gates. Any utilities are the CONTRACTOR's responsibility to obtain. Any soil erosion and sedimentation control devices required for the project are the responsibility and cost of the CONTRACTOR, including any plan preparation and permit fees.
  - 2.   CONTRACTOR to remove existing vegetation (alive or dead) from all four existing foundation and building walls. CONTRACTOR to remove all loose foundation mortar and broken foundation block below elevation 501.83.
  - 3.   Install new replacement foundation block and replacement mortar on all four foundation walls.
  - 4.   Construct temporary facilities, as needed, to remove existing trash rack, sluice gate appurtenances, and lower ladder and to install new sluice gate, trash rack and suction inlet valve.
  - 5.   Remove accumulated sediment and debris from inlet conduit and channel within the pump station building.
  - 6.   Install new trash rack within inlet conduit.
  - 7.   Remove existing sluice gate, stem and stem guides. Determine condition of existing sluice gate wall thimble. Remove rust tubercles as necessary to create a reasonably flat, vertical surface.

## SUGGESTED SEQUENCE OF CONSTRUCTION

8. Install new cast iron sluice gate, stem, and stem guides from the inlet channel to below the existing floor.
9. Construct temporary facilities to minimize the potential to flood the existing dry well upon removal of the suction inlet butterfly valve.
10. Remove existing 30-inch suction inlet butterfly valve, and install new 30-inch butterfly valve.
11. Test new butterfly valve installation.
12. Conduct select demolition of the existing concrete and steel wet well platforms, as required to stage the replacement of the pump room floor. Accumulated sediment from the platforms can be deposited into wet well, but all other debris will be removed. All concrete, steel, etc. debris from the floor and platform demolition must be removed and disposed of off-site.
13. Relocate existing potassium permanganate storage tank to boiler/storage room. CONTRACTOR to provide temporary heat, if necessary. Demolish existing CMU block containment area.
14. Remove existing asbestos floor tiles.
15. Provide temporary facilities for demolition and replacement of the pump room floor. Make sure to maintain access for OWNER to pump motor floor.
16. Demolish various washroom/shower room items as noted, including a portion of an existing CMU wall.
17. Remove portion of existing pump room floor, maintaining access for NKWD personnel to motor platform above pump room floor.
18. Install new portion of new pump room floor.
19. Remove next portion of existing pump room floor maintaining access for NKWD personnel to motor platform above pump floor.
20. Install next portion of new pump room floor.
21. Remove final portion of existing pump room floor maintaining access for NKWD personnel to motor platform above pump room floor.
22. Install final portion of new operations room floor, including new floor hatch and access plating for new sluice gate stem and floor stand.
23. Relocate existing potassium permanganate storage tank back to new containment area within pump room.
24. Complete the sluice gate stem and floor stand installation. Install new electric motor actuator with conduit and wiring back to motor control center.
25. Install new fiberglass reinforced plastic ladders and platforms within wet well.
26. Install new wet well lighting fixtures, conduit and wiring to existing lighting panel.
27. Test new sluice gate installation.
28. Remove existing semi-circular and rectangular windows throughout the facility. Remove existing river doors and windows on east side of building within the operations room.
29. Install new semi-circular and rectangular windows throughout the facility.
30. Construct new wood frame wall with one rectangular window and a new motor operated damper with louver on east side of building. Provide electrical conduit, wiring and controls for new damper.
31. Provide complete cleaning of debris from facility and restore site areas used for storage and CONTRACTOR use.

## SUGGESTED SEQUENCE OF CONSTRUCTION

32. Finish all carpentry, painting, mechanical, and electrical work associated with items discussed above.
33. Complete commissioning and acceptance testing of installed equipment.

### **PART 2 PRODUCTS**

NOT USED

### **PART 3 EXECUTION**

NOT USED

END OF SECTION

## SUGGESTED SEQUENCE OF CONSTRUCTION

THIS PAGE LEFT INTENTIONALLY BLANK



**SECTION 01 1125  
MEASUREMENT AND PAYMENT**

**PART 1 GENERAL**

**1.1 DESCRIPTION**

- A. Payment for various items of the Bid, as further specified herein, shall include all compensation to be received by the CONTRACTOR for furnishing all tools, equipment, supplies, and manufactured articles, and for all labor, operations, and incidentals appurtenant to the items of work being described, as necessary to complete the various items of the WORK all in accordance with the requirements of the Contract Documents. Work also includes all costs of permits and cost of compliance with the regulations of public agencies having jurisdiction, including Safety and Health Requirements of the State of Kentucky, and the Occupational Safety and Health Administration of the U.S. Department of Labor (OSHA). No separate payment will be made for any item that is not specifically set forth in the Bid, and all costs therefore shall be included in the prices named in the Bid for various appurtenant items of work.
- B. Payment for each respective item shall include such costs for the furnishing of drawings, submittals, samples, tools and appliances necessary to complete the work as specified and shown on the Contract Drawings.
- C. Payment for each item shall include the cost for documentation, record drawings, O&M manuals, training, and start-up services.
- D. No direct or separate payment will be made for providing miscellaneous temporary or accessory works, CONTRACTOR'S field office, layout surveys, sanitary requirements, testing, safety devices, approval drawings, record drawings, water supplies, power, maintaining traffic, removal of waste, watchman, bonds, insurance, and all other requirements of the Contract Documents. Compensation for all such services, things and materials shall be included in the prices stipulated for the lump sum and unit price Pay Items as identified in the Contract.
- E. The CONTRACTOR shall verify the rating and horsepower of the equipment he proposes to furnish and shall provide for any necessary electrical changes to accommodate the equipment furnished at no change in the CONTRACT price.
- F. Where work is to be paid for by units of length, area, weight or volume, all Work accepted under this Contract will be measured by the OWNER, or their duly authorized representative, and the quantities of various items of Work performed will be determined by the OWNER/ENGINEER, as the basis for final settlement. For the calculation of quantities in which the computation of area by geometric methods would be comparatively laborious, use of automated calculation tools, such as AutoCAD, may be used with prior OWNER approval.

**1.2 RELATED PROVISIONS SPECIFIED ELSEWHERE**

- A. Payments to CONTRACTOR: Refer to General Conditions.

## MEASUREMENT AND PAYMENT

- B. Changes in Contract Price: Refer to General Conditions.

### 1.3 PROJECT BID ITEMS

- A. Procurement Item – Bid Form 00300; Lump Sum Price Item – Item 1.

- 1. Item 1 Mobilization
  - a. Description: Item 1 is for CONTRACTOR mobilization of personnel, materials and equipment to the project site.
  - b. Measurement: Lump Sum (LS)
  - c. Payment: Payment for this work shall be made at the lump sum price bid for Mobilization. Price shall include all labor, materials and equipment and incidentals necessary to complete work.

- B. Procurement Item – Bid Form 00300; Unit Price Items – Items 2 and 3.

- 1. Item 2 Foundation Tuck Pointing
  - a. Description: Item 2 is for tuck pointing of the existing stone masonry for the Ohio River Pump Station Number 2 Building from elevation 501.83 to the ground surface (west elevation) or elevation 455 (north, east and south elevations), as directed by the OWNER.
  - b. Measurement: Lineal Foot (LF)
  - c. Payment: Payment for this work shall be made at the unit price bid per lineal foot of Foundation tuck pointing. Price shall include all labor, demolition, removals, disposal, materials and equipment and incidentals necessary to complete work. If the quantity is exhausted before final completion, additional money may be allocated by Change Order. However, at the completion of the Contract any remaining funds will be deducted from the total contract price by means of a Change Order.
- 2. Item 3 Foundation Block Replacement
  - a. Description: Item 3 is for replacement of broken foundation stone within the limits of the existing stone masonry for the Ohio River Pump Station Number 2 Building from elevation 501.83 to the ground surface (west elevation) or elevation 455 (north, east and south elevations), as directed by the OWNER.
  - b. Measurement: Linear Foot (LF)
  - c. Payment: Payment for this work shall be made at the unit price bid per linear foot of foundation block replacement. The foundation block replacement quantities will be computed on the basis of linear feet of foundation block removed and replaced with an average height of 8 inches, an average depth of 12 inches and field measured lengths, measured to the nearest inch. Price shall include all labor, materials, equipment and incidentals necessary to complete the work. If the quantity is exhausted before final completion, additional money may be allocated by Change Order. However, at the completion of the Contract any remaining funds will be deducted from the total contract price by means of a Change Order.

## MEASUREMENT AND PAYMENT

- C. Gross Price Item – Bid Form 00300, Lump Sum Price Item – Item 4
1. Contract Lump Sum for all work as specified and shown except items 1, 2, 3, and 5.
    - a. Description: Item 4 includes all work specified in the Contract Documents, except for Bid items 1, 2, 3, and 5. All work shall be in accordance with the administrative and procedural requirements specified in Division 01 as well as the broader requirements of the General Conditions.
    - b. Measurement and Payment: The lump sum payment for item 4 shall be full compensation for the furnishing of all labor, equipment, materials, and superintendent for all work specified or shown on the Contract Documents except for Bid Items as described in 1, 2, 3, and 5.
- D. Allowance Item – Bid Form 00300, Item 5.
1. Item 5 is an allowance for any labor, equipment and disposal necessary for unforeseen conditions encountered during the installation of the Work. Given the age of the existing structure, it is possible to have situations, not described on the drawings or within the specifications, which may alter the completion of a portion of the work. The final determination of any unforeseen conditions rests solely with the OWNER.
    - a. Description: Item 5 is an allowance for any labor, equipment and disposal necessary to address unforeseen conditions encountered during the progress of the Work. All work to be performed as directed by the OWNER.
    - b. Measurement: Lump Sum (LS)
    - c. Payment: The actual amount paid under this item shall be negotiated between the CONTRACTOR and OWNER and deducted from the allowance. If the allowance is exhausted before final completion, additional money may be allocated by Change Order. However, at the completion of the Contract any remaining funds will be deducted from the total contract price by means of a Change Order.
- E. Item 6 Total Price for Base Work
1. Description: Item 6 is the sum of the Total Prices for items 1 through 5.

### **PART 2 PRODUCTS**

NOT USED

### **PART 3 EXECUTION**

NOT USED

END OF SECTION

**MEASUREMENT AND PAYMENT**

**THIS PAGE INTENTIONALLY LEFT BLANK**

**SECTION 01 12 00  
MAJOR EQUIPMENT SUPPLIERS**

**PART 1      GENERAL**

1.1    DEFINITIONS

- A.    Manufacturers or suppliers, as used in the context of "approved manufacturers or suppliers of major equipment," shall mean the manufacturers or suppliers listed in Article 1.3 of this Section.

1.2    INSTRUCTIONS FOR BIDDING MAJOR EQUIPMENT

- A.    Furnish, for base bid, equipment by any of the suppliers listed in Article 1.4  
ACCEPTABLE MANUFACTURERS OF MAJOR EQUIPMENT.

1.3    ACCEPTABLE MANUFACTURERS OF MAJOR EQUIPMENT

- A.    General Construction:
  - 1.    Suction Inlet Butterfly Valve:.....Dezuirk Valve, or Approved Equal
  - 2.    Cast Iron Sluice Gate: Rodney Hunt, Coldwell Wilcox, or Approved Equal
  - 3.    Electric Motor Actuator:.....Rotork, Auma, or Approved Equal
  - 4.    Floor Doors/Hatches: :.....Bilco, Halliday, or Approved Equal
  - 5.    Windows:.....Anderson, Pella, or Approved Equal

**PART2      PRODUCTS (NOT USED)**

**PART3      EXECUTION (NOT USED)**

END OF SECTION

**MAJOR EQUIPMENT SUPPLIERS**

**THIS PAGE LEFT BLANK INTENTIONALLY**

**SECTION 01 25 13  
SUBSTITUTION PROCEDURES**

**PART 1      GENERAL**

1.1 SECTION INCLUDES

- A. Options for making product or process selections.
- B. Procedures for proposing equivalent construction products or processes, including preapproved, prequalified, and approved products or processes.

1.2 DEFINITIONS

- A. Product: Means materials, equipment, or systems incorporated into the Project. Product does not include machinery and equipment used for production, fabrication, conveying, and erection of the Work. Products may also include existing materials or components designated for reuse.
- B. Process: Any proprietary system or method for installing system components resulting in an integral, functioning part of the Work. For this Section, the word Product includes Processes.

1.3 SELECTION OPTIONS

- A. Preapproved Products: Construction products of certain manufacturers or suppliers designated in the Specifications as "preapproved." A list of preapproved products is maintained by OWNER. Preapproved products for this Project are designated as preapproved in the Specifications. Products of other manufacturers or suppliers will not be acceptable for this Project and will not be considered under the submittal process for approving alternate products.
- B. Prequalified Products: Construction products of certain manufacturers or suppliers designated in the Specifications as "prequalified." Prequalified products for this Project are designated as prequalified in the Specifications. Products of other manufacturers or suppliers will not be acceptable for this Project and will not be considered under the submittal process for approving alternate products.
- C. Approved Products: Construction products or processes of certain manufacturers or suppliers designated in the Specifications followed by the words "or approved equal." Approval of alternate products or processes not listed in the Specifications may be obtained through provisions for product options and substitutions in Document 00 7000 - General Conditions, and by following the submittal procedures specified in 01 3300 - Submittal Procedures. The procedure for approval of alternate products is not applicable to preapproved or prequalified products.
- D. Product Compatibility: To the maximum extent possible, provide products that are of the same type or function from a single manufacturer, make, or source. Where more than one choice is available as a CONTRACTOR's option, select a product which is compatible with other products already selected, specified, or in use by OWNER.

## **SUBSTITUTION PROCEDURES**

### **1.4 CONTRACTOR'S RESPONSIBILITY**

- A. CONTRACTOR's responsibility related to product options and substitutions is defined in Section 00 7200, General Conditions.
- B. Furnish information ENGINEER deems necessary to judge equivalency of the alternate product.
- C. Pay for laboratory testing, as well as any other review or examination costs, needed to establish the equivalency between products in order to obtain information upon which ENGINEER can base a decision.
- D. If ENGINEER determines that an alternate product is not equal to that named in the Specifications, CONTRACTOR shall furnish one of the specified products.

### **1.5 ENGINEER'S REVIEW**

- A. Alternate products or processes may be used only if approved in writing by ENGINEER. ENGINEER's determination regarding acceptance of a proposed alternate product is final.
- B. Alternate products will be accepted if the product is judged by ENGINEER to be equivalent to the specified product or to offer substantial benefit to OWNER.
- C. OWNER retains the right to accept any product or process deemed advantageous to OWNER, and similarly, to reject any product or process deemed not beneficial to OWNER.

### **1.6 SUBSTITUTION PROCEDURE**

- A. Collect and assemble technical information applicable to the proposed product to aid in determining equivalency as related to the approved product specified.
- B. Submit a written request for a construction product to be considered as an alternate product.
- C. Submit the product information after the effective date of the Agreement and within the time period allowed for substitution submittals given in Section 00 7200, General Conditions. After the submittal period has expired, requests for alternate products will be considered only when a specified product becomes unavailable because of conditions beyond CONTRACTOR's control.
- D. Submit six (6) copies of each request for alternate product approval. Include the following information:
  - 1. Complete data substantiating compliance of proposed substitution with Contract Documents.
  - 2. For products:
    - a. Product identification, including manufacturer's name and address.



**SECTION 01 25 13  
SUBSTITUTION PROCEDURES**

- b. Manufacturer's literature with product description, performance and test data, and reference standards.
  - c. Samples, as applicable.
  - d. Name and address of similar projects on which product was used and date of installation. Include the name of OWNER, ENGINEER, and CONTRACTOR.
- 3. For construction methods:
    - a. Detailed description of proposed method.
    - b. Drawings illustrating methods.
  - 4. Itemized comparison of proposed substitution with product or method specified.
  - 5. Data relating to changes in construction schedule.
  - 6. Relation to separate contracts, if any.
  - 7. Accurate cost data on proposed substitution in comparison with product or method specified.
  - 8. Other information requested by ENGINEER.
- E. Approved alternate products will be subject to the same review process as the specified product would have been for shop drawings, product data, and samples.

**PART 2      PRODUCTS (NOT USED)**

**PART 3      EXECUTION (NOT USED)**

END OF SECTION

**SUBSTITUTION PROCEDURES**

**THIS PAGE INTENTIONALLY LEFT BLANK**

**SECTION 01 31 19**  
**PROJECT MEETINGS**

**PART 1**      **GENERAL**

1.1    PRECONSTRUCTION MEETING

- A.    Prior to the delivery of materials or the start of any construction, CONTRACTOR shall request a Preconstruction Meeting from ENGINEER. A minimum seven (7) working days' notification to meeting participants shall be required.
  
- B.    Schedule:
  - 1.    ENGINEER will establish the meeting place, time and date, distribute agenda, notify participants, and administer the meeting. CONTRACTOR shall notify major Subcontractors.
  
- C.    Attendance:
  - 1.    OWNER
  - 2.    ENGINEER
  - 3.    CONTRACTOR
  - 4.    Major Subcontractors
  - 5.    Utility Companies
  - 6.    Safety Representatives
  - 7.    Governmental Agencies
  
- D.    Agenda:
  - 1.    Distribution by CONTRACTOR and discussion, review and acceptance of:
    - a.    List of names and telephone numbers for superintendent, foreman and other key personnel.
    - b.    List of major Subcontractors and Suppliers.
    - c.    Projected construction preliminary progress schedules.
    - d.    Preliminary schedule of Shop Drawings and Sample submittals.
    - e.    Estimated monthly payment schedule and schedule of values
  - 2.    Critical Work sequencing.
  - 3.    Major equipment deliveries and priorities.
  - 4.    Project coordination.
  - 5.    Responsibilities of OWNER, ENGINEER, CONTRACTOR and other agencies.
  - 6.    Procedures and processing of:
    - a.    Field decisions.
    - b.    Proposal requests.
    - c.    Submittals.
    - d.    Change Orders.
    - e.    Applications for Payment.
  - 7.    Adequacy of distribution of Contract Documents.
  - 8.    Procedures for maintaining Record Documents.
  - 9.    Use of premises.
  - 10.    Construction facilities, controls and construction aids.
  - 11.    Temporary utilities.
  - 12.    Safety and first aid procedures.
  - 13.    Security procedures.

## PROJECT MEETINGS

14. Housekeeping procedures.
15. Testing

### E. Minutes:

1. ENGINEER will prepare and distribute copies to participants within seven (7) days of meeting. Participants shall report corrections and comments within ten (10) days of receipt of minutes.

## 1.2 PROGRESS MEETINGS

### A. Periodic Progress Meetings will be held as required by the progress of the Work.

### B. Schedule:

1. ENGINEER will establish the meeting place, time and date, distribute agenda, notify participants and administer the meeting. CONTRACTOR shall notify major Subcontractors.

### C. Attendance:

1. ENGINEER
2. CONTRACTOR
3. Subcontractor as appropriate to the agenda.
4. Suppliers as appropriate to the agenda.
5. Others

### D. Agenda:

1. Review minutes of previous meeting.
2. Review of work progress since previous meeting.
3. Review field observations, problems, conflicts.
4. Review problems which impede Construction Schedules.
5. Review of off-site fabrication, delivery schedules.
6. Review corrective measures and procedures to regain projected schedule.
7. Review revisions to Construction Schedules.
8. Review plan progress, schedule, during succeeding Work period.
9. Review coordination of schedules.
10. Review submittal schedules; expedite as required.
11. Review maintenance of quality standards.
12. Review proposed changes for:
  - a. Effect on Construction Schedule and on completion date.
  - b. Effect on other Contracts of the Project.
13. Other business.

### E. Minutes:

1. ENGINEER will prepare and distribute copies to participants and OWNER within seven (7) days of meeting for review at the next meeting.

**PROJECT MEETINGS**

**PART 2      PRODUCTS (NOT USED)**

**PART 3      EXECUTION (NOT USED)**

END OF SECTION

**PROJECT MEETINGS**

**THIS PAGE INTENTIONALLY LEFT BLANK**

**SECTION 01 33 00**  
**SUBMITTAL PROCEDURES**

**PART 1**      **GENERAL**

1.1      SUBMITTALS - GENERAL

- A.      CONTRACTOR shall submit Shop Drawings, product data, and Samples, as required by the individual Specification Sections, to ENGINEER for review in accordance with the provisions of paragraphs 6.19 through 6.20, inclusive, of the General Conditions.

1.2      PROGRESS SCHEDULES

- A.      CONTRACTOR shall submit three (3) copies of Progress Schedules indicating the starting and completion dates of the various stages of the Work and estimated payments during the next three (3) months to ENGINEER.
- B.      Proposed Progress Schedules shall be submitted to ENGINEER prior to the preconstruction meeting. CONTRACTOR shall distribute copies of the Progress Schedules during the preconstruction meeting for discussion.
- C.      Progress Schedules shall be updated by CONTRACTOR and submitted to ENGINEER, as a part of applications for progress payments, through completion of the Work. *Failure to update progress schedule may be the basis for rejection of applications for progress payments.*

1.3      SUBMITTAL SCHEDULE

- A.      CONTRACTOR shall submit three (3) copies of a Submittal Schedule indicating the individual items and submission dates to ENGINEER and OWNER. A preliminary Schedule in accordance with the requirements in the General Conditions shall be submitted by CONTRACTOR prior to the preconstruction meeting. Copies of this preliminary Schedule shall be made available by CONTRACTOR during the preconstruction meeting. A final Schedule shall be submitted by CONTRACTOR at least ten (10) days prior to submitting the first Application for a Payment.

1.4      SCHEDULE OF VALUES

- A.      CONTRACTOR, if applicable, shall submit three (3) copies of Schedules of Value of the Work to ENGINEER. A preliminary Schedule of Values shall be submitted by CONTRACTOR 30 days from the award of the project. A final Schedule of Values, prepared in accordance with Paragraph 14.01 of the General Conditions and presented in sufficient detail to serve as the basis for payments during construction, shall be submitted to OWNER and ENGINEER for review and approval at least ten (10) days prior to submitting the first Application for Payment.

1.5      APPLICATIONS FOR PAYMENT

- A.      CONTRACTOR shall submit Applications for Payment to ENGINEER in

## **SUBMITTAL PROCEDURES**

accordance with the provisions of Article 14 of the General Conditions. Applications for Payment shall be made on forms provided by or approved by the ENGINEER.

- B. Sample CONTRACTOR's Application/Declaration, Payment Schedule and ENGINEER's Certificate forms for this purpose are included in the Contract Documents. Copies of these forms, with Project specific information completed by the ENGINEER, will be given to the CONTRACTOR at the preconstruction meeting or, if applicable, after approval of the final Schedule of Values.
- C. CONTRACTOR shall submit a completed Payment Schedule with an executed Contractor's Application for Payment and Contractor's Declaration to ENGINEER not more often than once per month.
- D. CONTRACTOR shall also submit with each payment, beginning with the second payment request, the Sworn Statement regarding partial waiver of liens.
- E. ENGINEER will certify payments with the use of ENGINEER's Certificate for Payment.

### **1.6 SHOP DRAWINGS**

- A. Shop Drawings shall be presented in a clear and thorough manner. Details shall be identified by reference to Plan Sheet Number and Detail, and Specification Section Number and Page Number. A standard shop drawing submittal form will be provided by ENGINEER prior to the start of the Work.

### **1.7 PRODUCT DATA**

- A. Product data shall be presented in a clear and thorough manner identified the same as the Shop Drawings. Included with the information shall be performance characteristics and capacities depicting dimensions and clearances required.
- B. Manufacturer's standard schematic drawings and diagrams shall be modified to delete information which is not applicable to the Work. Manufacturer's standard information shall be supplemented to provide information specifically applicable to the Work.

### **1.8 SAMPLES**

- A. Samples shall be of sufficient size and quantity to clearly illustrate functional characteristics of the product with integrally related parts and attachment devices depicting full range of color, texture and pattern.

### **1.9 SUBMISSION REQUIREMENTS**

- A. CONTRACTOR shall make submittals in accordance with the approved schedule, and in such sequence as to cause no delay in the Work. No damages will be awarded or extension of time granted due to the Shop Drawing and product data review process.



## SUBMITTAL PROCEDURES

- B. CONTRACTOR shall submit an entire package of Shop Drawings and product data information for major items of Work so that ENGINEER can review the package as a unit.
- C. The number of submittals required shall be one (1) digital copy in .pdf format as the initial review document. Once the ENGINEER has determined the submittal conforms to the intent of the specifications, the CONTRACTOR shall provide three (3) reproducible paper copies and three (3) prints per Shop Drawings and four (4) copies of each product data information sheet. Submittals shall contain the following information:
1. Field dimensions, clearly identified as such.
  2. Relation to adjacent or critical features of the Work or materials.
  3. Applicable standards, such as ASTM or Federal Specification Numbers.
  4. Identification of deviations from Contract Documents.
  5. Identification of revisions on resubmittals.
  6. CONTRACTOR's stamp indicating as a minimum the Project Title, Date of Submission, Date of Previous Submission, and Specification Section number.
    - a. CONTRACTOR's stamp shall be initialed or signed, certifying the CONTRACTOR's review and approval of submittal per General Conditions paragraph 6.20, verification of products, field measurements, field construction criteria, and coordination of the information within the submittal with requirements of the Work and of Contract Documents.
- D. ENGINEER shall provide a cover dispensation sheet or affix a stamp and initials or signature and indicate confirmation or requirements for resubmittal. ENGINEER shall return to CONTRACTOR one (1) digital copy during the submittal review process, which may include up to one (1) of the reproducibles and three (3) copies of the product data information for distribution or for resubmission.
- E. Digital copies shall be either emailed or transferred via secure file transfer protocol (FTP) or other secure digital means, as agreed between OWNER, ENGINEER and CONTRACTOR. Files transferred by email or FTP shall be considered delivered if received prior to 5:00 pm. Files received after 5:00pm shall be considered as being received the next day. Files transferred by FTP shall be accompanied by an email to ENGINEER or CONTRACTOR indicating the transfer of the document. Scanned copies which are illegible shall be cause for rejection.
- F. REVIEW SCHEDULE: The following review times are expected for prompt review so as not to delay the work:
1. First Submission- Return comments to CONTRACTOR within:
    - a. ENGINEER: Fourteen (14) consecutive calendar days from receipt of first submission.
  2. Resubmission/Rejection-
    - a. CONTRACTOR: If first submission is returned with a rejected or revise and resubmit or if additional information is requested by the

## SUBMITTAL PROCEDURES

- ENGINEER, revise and return to the ENGINEER within fourteen (14) consecutive calendar days.
  - b. ENGINEER: Review and provide comment to CONTRACTOR: Return to ENGINEER within seven (7) consecutive calendar days of the receipt of the resubmission or request for additional information (RFI).
- 3. Additional (more than one (1)) Resubmission/Rejections of same shop drawing:
  - a. CONTRACTOR: Upon receipt from ENGINEER, provide updated shop drawings or additional information, as requested, within seven (7) consecutive calendar days.

### 1.10 RESUBMISSION REQUIREMENTS

- A. CONTRACTOR shall make all corrections or changes in the submittals required by ENGINEER and resubmit. CONTRACTOR shall indicate any changes which have been made other than those requested by ENGINEER.

### 1.11 SPECIFICATION SECTION REQUIREMENTS

- A. Miscellaneous schedules, field reports, test reports, affidavits, certificates, permits, agreements and other items identified in the Specification Sections, or as requested by ENGINEER shall be submitted to ENGINEER in duplicate. As a minimum, these submittals should be identified with the Project title, date of submission, and Specification section reference.

### 1.12 MANUFACTURER'S OPERATION AND MAINTENANCE DATA

- A. CONTRACTOR shall furnish one (1) digital file in .pdf format to the ENGINEER as the initial submittal and four (4) paper copies after the ENGINEER has indicated the submittal conforms to the contract requirements, of all operation and maintenance data required per the various Specification Sections. Prior to 50% completion of the Project, CONTRACTOR shall have submitted one (1) acceptable copy to ENGINEER for review.
- B. Operation and maintenance data shall be bound in a suitable number of 3-inch or 4-inch, 3-ring hard cover binders. Permanently imprinted on the cover shall be the words "Manufacturer's Operation and Maintenance Data", Project title, location of the Project, and the date. A table of contents shall be provided in the front of each binder to list the various sections in the manual.
- C. Information to be provided in each section of the manual, for each piece of equipment and project component shall include, but not be limited to, detailed equipment drawings; sections cut through all of the major equipment and subassemblies; installation and operational procedures; complete wiring and piping schematics; lubrication materials and procedures; maintenance procedures; and parts lists complete enough to permit identification of parts by nomenclature, manufacturer's part number and use.
- D. At the front of each section a maintenance schedule shall be provided for each

## SUBMITTAL PROCEDURES

piece of equipment in the section. The schedule shall display the daily, weekly, monthly, semi-annual, annual or fraction thereof, lubrication and preventative maintenance required in order to meet warranty conditions and the manufacturer's recommendations for optimum performance and life of the unit. A common schedule format is to be developed and used for all of the sections. Photocopies or reproductions of the manufacturer's literature will not be accepted.

- E. O&M Manual Review schedule shall follow the same schedule as the shop drawings schedule in 1.10.E of this Specification Section, unless otherwise instructed by the ENGINEER.

### 1.13 PHOTOGRAPHS

#### A. Preconstruction Photographs:

- 1. CONTRACTOR shall furnish ENGINEER with digital photos of each major project area, including staging areas and areas for ingress and egress of the Project site, to record the existing conditions of the Project areas prior to commencement of construction activities. OWNER shall have the authority to designate areas for which coverage may be added or omitted. Digital photos shall be taken prior to mobilization to the site and/or placement of materials or equipment on the construction area and furnished one (1) week prior to the preconstruction meeting. Photos will be provided on compact disc.

#### B. Construction Photographs:

- 1. CONTRACTOR shall furnish to ENGINEER digital color photos of the construction progress on a disc. At a minimum, ten (10) photos of each main construction area, or areas directed by OWNER and/or ENGINEER, shall be taken. Each photo is to be numbered and each number is to correspond to a separate photo identification sheet, in Word format, included on the compact disc. The photo information shall include, at a minimum, the photo number, date taken and description of the photo view. CONTRACTOR shall submit the digital photographs monthly along with the Application for progress Payment as described in Article 14 of the General Conditions.

**PART2**      **PRODUCTS (NOT USED)**

**PART3**      **EXECUTION (NOT USED)**

END OF SECTION

**SUBMITTAL PROCEDURES**

**THIS PAGE LEFT BLANK INTENTIONALLY**

**SECTION 01 35 23  
JOB CONDITIONS**

**PART 1      GENERAL**

1.1 PROJECT CONDITIONS

- A. Prior to installation of material, equipment and other work, verify with Subcontractors, material or equipment manufacturers, and installers that the substrate or surface to which those materials attach is acceptable for installation of those materials or equipment. (Substrate is defined as building surfaces to which materials or equipment is attached to i.e., floors, walls, ceilings, etc.).
  
- B. Correct unacceptable substrate until acceptable for installation of equipment or materials.
  
- C. Maintaining Facility Operations:
  - 1. Facility is currently operating. Ensure construction activities do not interfere with OWNER's operation of facility. Planned shut-downs may be permitted. CONTRACTOR must notify OWNER at least seven (7) days in advance of any shut-down. During periods of high water demand the OWNER may not allow any shutdowns. From May 1<sup>st</sup> through October 31<sup>st</sup>, the ORPS2 must remain in service to meet customer demand. CONTRACTOR may be allowed day length shutdowns during this period of the year. Day duration shutdowns would be considered less than 8 hours, and only allowed between the hours of 8:00 a.m. and 4:00 p.m., with the facility back at full capacity following the shutdown. From November 1st through April 30th, the ORPS2 may be shut down for longer periods of time to allow the CONTRACTOR to complete the work. Longer duration shut-downs must be coordinated with the OWNER, and be during periods of low water demand. The OWNER is prepared to remove the facility from service for three (3) months, beginning January 1<sup>st</sup> through March 31<sup>st</sup>, at which time the facility will be ready to begin normal operation.
  - 2. Control emissions of gases or particulates resulting from application of adhesives, paints or coatings, or produced by welding, grinding or other activities.
    - a. Provide temporary partition walls, drapes or other screening methods to isolate areas under construction from other areas of operation adjacent to construction areas.
    - b. Provide temporary ventilation of construction area:
      - (1) Exhaust air to outdoor discharge.
      - (2) Locate exhaust air discharge at an elevation sufficient to prevent personnel contact with exhaust air.
      - (3) Locate exhaust air discharge to avoid short-circuiting with existing supply air intakes.
  
- D. The project area is subject to moist atmosphere and an atmosphere that can be potentially corrosive to equipment. Special care shall be taken by CONTRACTOR to ensure proper storage and use of equipment to minimize exposure of that equipment until controls are in place.

## **JOB CONDITIONS**

- E. A limited lead paint and asbestos assessment was completed at the pumping station in 2013 and it was found that these materials are present in certain areas of the facility.
  - 1. CONTRACTOR shall be responsible for proper protection, removal and disposal of materials in accordance with these Specifications and all current government regulation and requirements.
  - 2. A removal and disposal plan is to be submitted to OWNER for its review.
  - 3. A copy of the Assessment report is included in these Contract Documents for CONTRACTOR'S information.
- F. The OWNER is also aware of asbestos floor tiles located within the existing chemical containment area. These tiles will be removed under this project.
- G. The existing cranes located within the ORPS2 facility are available for use at the CONTRACTOR'S risk. CONTRACTOR shall demonstrate their personnel have proper training in the use of the crane(s) and shall be responsible for the safe operation. Prior to granting permission, the crane(s) will be inspected by the OWNER. Following use of a crane, the device will be reinspected by the OWNER. Any damage to the crane, building, or OWNER'S equipment by the CONTRACTOR'S use of the crane will be reimbursed to the OWNER.
- H. The project site is located within the normal water level of the Ohio River. Some work activities will be required to be performed over open water which can fluctuate from time to time. In addition, a portion of the wet well is hydraulically connected to the river and the work within and above the wet well can occur over water.
  - 1. The CONTRACTOR is responsible for complying with the Occupational Safety and Health Administration regulations governing work in and around open water.
  - 2. The CONTRACTOR can obtain information from the US Army Corps of Engineers and other sources regarding historical water surface elevations of the river. One source is the following website – [http://waterdata.usgs.gov/oh/nwis/uv?site\\_no=03255000](http://waterdata.usgs.gov/oh/nwis/uv?site_no=03255000)
- I. The project site is located within the normal water level of the Ohio River, which is used for commercial and recreational watercraft. The work associated with this project may not interfere with normal navigation of the river. Interruption of river navigation by the CONTRACTOR during the course of the project could be subject to fine(s) by authorities having jurisdiction. Any fines incurred would be at the CONTRACTOR'S cost.

**PART 2**      **PRODUCTS (NOT USED)**

**PART 3**      **EXECUTION (NOT USED)**

END OF SECTION

**SECTION 01 35 43**  
**ENVIRONMENTAL PROTECTION AND SPECIAL CONTROLS**

**PART 1      GENERAL**

1.1 SCOPE OF WORK

- A. Minimizing the pollution of air, water, or land; control of noise, the disposal of solid waste materials, and protection of deposits of historical or archaeological interest.

1.2 QUALITY ASSURANCE

- A. CONTRACTOR shall retain the services of an independent laboratory to conduct concrete materials testing to assure all work complies with this specification.
- B. CONTRACTOR shall comply with all OSHA regulations concerning work over open water and within confined spaces that may be present within the project limits. CONTRACTOR shall retain an engineer licensed in the State of Kentucky for the design of safety systems as may be required.

1.3 SUBMITTALS

- A. Shop Drawings:
  - 1. Prior to the start of any construction activities submit:
    - a. A detailed proposal of all methods of control and preventive measures to be utilized for environmental protection.
    - b. A drawing of the work area, haul routes, storage areas, access routes and current land conditions including trees and vegetation.

**PART 2      PRODUCTS (NOT USED)**

**PART 3      EXECUTION**

3.1 INSTALLATION

- A. Employ and utilize environmental protection methods, obtain all necessary permits, and fully observe all local, state, and federal regulations including U.S. EPA, US Army Corps of Engineers, Kentucky Division of Water and the City of Fort Thomas.

## ENVIRONMENTAL PROTECTION AND SPECIAL CONTROLS

### B. Land Protection:

1. Except for any work or storage area and access routes specifically assigned for the use of the CONTRACTOR, the land areas outside the limits of construction shall be preserved in their present condition. CONTRACTOR shall confine his construction activities to areas defined for work within the Contract Documents.
2. Manage and control all work or storage areas, and access routes to prevent sediment from entering nearby water or land adjacent to the work site.
3. Restore all disturbed areas and establish permanent type of locally adaptable vegetative cover.
4. Except for areas designated by the Contract Documents to be cleared and grubbed, the Contractor shall not deface, injure or destroy trees and vegetation, nor remove, cut, or disturb them without approval of the ENGINEER. Any damage caused by CONTRACTOR's equipment or operations shall be restored as nearly as possible to its original condition at CONTRACTOR's expense.

### C. Surface Water Protection:

1. Utilize, as necessary, erosion control methods to protect side and backslopes, minimize and the discharge of sediment to the surface water leaving the construction site. Physically retard the rate and volume of runoff and runoff by:
  - a. Implementing structural practices such as diversion swales, terraces, straw bales, silt fences, berms, storm drain inlet protection, rock outlet protection, sediment traps and temporary basins.
  - b. Implementing vegetative practices such as temporary seeding, permanent seeding, mulching, sod stabilization, vegetative buffers, hydroseeding, anchored erosion control blankets, sodding, vegetated swales or a combination of these methods.
  - c. Providing Construction sites with graveled or rock access entrance and exit drives and parking areas to reduce the tracking of sediment onto public or private roads.
2. Discharges from the construction site shall not contain pollutants at concentrations that produce objectionable films, colors, turbidity, deposits or noxious odors in the receiving stream or waterway.
3. Demolition debris shall not be allowed to fall into the Ohio River from the project site and shall be disposed off site. Any fines resulting from the improper disposal of demolition material shall be the responsibility of the CONTRACTOR.

### D. Floodplain Protection

1. The existing ORPS2 property is located within the 100-year floodplain. The CONTRACTOR may not alter the property through the use of fill materials without obtaining an approval from the Kentucky Division of Water – Floodplain Management Section and the US Army Corps of Engineers.



## ENVIRONMENTAL PROTECTION AND SPECIAL CONTROLS

- E. Solid Waste Disposal:
1. Collect solid waste on a daily basis.
  2. Provide disposal of degradable solid waste to an approved solid waste disposal site.
  3. Provide disposal of non-degradable solid waste to an approved solid waste disposal site or in an alternate manner approved by ENGINEER and regulatory agencies.
  4. No building materials wastes or unused building materials shall be buried, dumped, or disposed of on the site.
  5. No building materials wastes, demolition debris, or unused building materials shall be deposited within the Ohio River.
  6. No processing of building materials to separate recyclable items from non-recyclable items may occur on the site without the OWNER's permission.
- F. Fuel and Chemical Handling:
1. Store and dispose of chemical wastes in a manner approved by regulatory agencies.
  2. Take special measures to prevent chemicals, fuels, oils, greases, herbicides, and insecticides from entering drainage ways.
  3. Do not allow water used in onsite material processing, concrete curing, cleanup, and other waste waters to enter a drainage way(s) or stream.
  4. CONTRACTOR shall provide containment around fueling and chemical storage areas to ensure that spills in these areas do not reach waters of the state.
- G. Control of Dust:
1. The control of dust shall mean that no construction activity shall take place without applying all such reasonable measures as may be required to prevent particulate matter from becoming airborne so that it remains visible beyond the limits of construction. Reasonable measures may include paving, frequent road cleaning, planting vegetative groundcover, application of water or application of chemical dust suppressants. The use of chemical agents such as calcium chloride must be approved by the Kentucky Transportation Cabinet.
  2. Utilize methods and practices of construction to eliminate dust in full observance of agency regulations.
  3. ENGINEER will determine the effectiveness of the dust control program and may request the CONTRACTOR to provide additional measures, at no additional cost to OWNER.
- H. Burning:
1. Do not burn material on the site. If CONTRACTOR elects to dispose of waste materials by burning, make arrangements for an off-site burning area and conform to all local and state agency regulations.
- I. Control of Noise:
1. Control noise by fitting equipment with appropriate mufflers.

## ENVIRONMENTAL PROTECTION AND SPECIAL CONTROLS

- J. Completion of Work:
1. Upon completion of work, leave area in a clean, natural looking condition.
  2. Ensure all signs of temporary construction and activities incidental to construction of required permanent work are removed.
  3. Grade, fill and seed all disturbed areas.
- K. Historical Protection:
1. The Kentucky Heritage Council has determined the existing Pumping Station No. 2 is a historic structure.
  2. If during the course of construction, evidence of deposits of historical or archaeological interests are found, cease work affecting find and notify OWNER. Do not disturb deposits until written notice from OWNER is given to proceed.
  3. CONTRACTOR will be compensated for lost time or changes in construction to avoid the find based upon normal change order procedures.

END OF SECTION

**SECTION 01 45 00  
QUALITY CONTROL**

**PART 1      GENERAL**

1.1 GENERAL REQUIREMENTS

- A. Sampling of materials will be made by CONTRACTOR in accordance with the methods designated by the Specifications. CONTRACTOR shall furnish such facilities as OWNER may require for collecting, storing, and forwarding samples to the CONTRACTORS Laboratory. CONTRACTOR in all cases shall furnish the required samples to OWNER without charge.

1.2 TESTS OF MATERIALS

- A. Materials in the Work shall meet the requirements of the Contract Documents.
- B. Tests of materials will be made as specified herein. OWNER shall have access to materials intended for use in the Work as well as to the plants where such materials are produced. Plant inspection may be made if the quantities are sufficient to warrant such inspection and if it is to the best interest of OWNER. In any case materials may be either inspected or tested when received on the Project.
- C. Materials shall not be used until approval has been received from OWNER. Approval of materials at the producing plant does not constitute a waiver of OWNER's right for re-examination at the Project site.
- D. Standards for testing materials, unless otherwise specified, shall be as established by the American Society for Testing and Materials (ASTM). Tests of materials will be made in accordance with the methods described or designated in the Specifications.
- E. Sampling and testing of materials not specifically mentioned shall be done by generally accepted methods, unless otherwise specified by ENGINEER. CONTRACTOR shall be responsible for hiring an independent third party testing agency, acceptable to the ENGINEER and OWNER, to conduct the sampling and testing as noted in the contract documents.

1.3 CERTIFICATION OF MATERIALS

- A. At the request of ENGINEER, CONTRACTOR shall provide ENGINEER with certification that the various materials to be used conform to the standards referred to in the Contract Documents.

1.4 SOURCE QUALITY CONTROL

- A. Testing identified in the Specifications as Source Quality Control, which is required to establish quality of materials, equipment or fabricated items, shall be paid for by CONTRACTOR.

## **QUALITY CONTROL**

### **1.5 INSPECTOR DAYS**

- A. Resident Project Representative(s) will be assigned to the Project by OWNER, as necessary (in the opinion of OWNER) to periodically monitor CONTRACTOR's work. When multiple CONTRACTOR crews are working on the Project, multiple Resident Project Representatives may be assigned to the Project.
- B. CONTRACTOR shall give OWNER at least 48 hours notice, exclusive of Saturdays, Sundays or holidays, when the Project requires an increase or decrease in the number of Resident Project Representatives.
  - 1. Failure to observe this requirement will either necessitate the charging of 4 hours show-up time if the Resident Project Representative appears on the Project, or the halting of all additional operations until a Resident Project Representative is available.
- C. Unless the Resident Project Representative is notified in advance, Inspector days will be charged when a Resident Project Representative appears on a project and CONTRACTOR decides not to work.
- D. A separate Inspector Day or a partial Inspector Day shall be charged for each and every Resident Project Representative working on a project for monitoring purposes.

**PART 2      PRODUCTS (NOT USED)**

**PART 3      EXECUTION (NOT USED)**

END OF SECTION

**SECTION 01 50 00**  
**TEMPORARY FACILITIES AND CONTROLS**

**PART 1**      **GENERAL**

1.1      SITE ACCESS AND PARKING

- A.      CONTRACTOR shall locate roads, drives, walks and parking facilities to provide uninterrupted access to construction offices, mobilization, Work, storage areas, and other areas required for execution of the Contract. Access drives and parking areas shall be hard surfaced unless otherwise approved by ENGINEER.
- B.      CONTRACTOR shall maintain driveways a minimum of 15 feet (5 m) wide between and around combustible materials in storage and mobilization areas.
- C.      CONTRACTOR shall maintain traffic areas as free as possible of excavated materials, construction equipment, products, snow, ice, and debris.
- D.      CONTRACTOR shall not utilize existing parking facilities intended for the OWNER's personnel for construction personnel or for CONTRACTOR's vehicles or equipment, unless written permission from OWNER of parking facility is obtained.

1.2      MAINTENANCE OF PLANT OPERATIONS

- A.      The Pumping Station must remain in operation at all times, 24 hours per day, 7 days per week. Work associated with this project shall be coordinated with OWNER and its operations staff. Any required equipment disruptions or shutdowns must be reviewed and approved by OWNER at least seven (7) days prior to the activities.

1.3      TRUCKING ROUTE AND PUBLIC ROAD MAINTENANCE

- A.      Prior to the start of construction, CONTRACTOR shall submit for review a schedule and list indicating the streets and roads within the municipality that his equipment will use off the Project site.
- B.      CONTRACTOR shall comply with all safety requirements, weight restrictions and speed limits.
- C.      Paved streets shall be maintained in a reasonable state of cleanliness and CONTRACTOR shall remove accumulations of debris, dirt or mud caused by his operations. Removal shall be done in such a manner as to prevent the release of dust. This shall be done at least every day at the close of each day's operation or additionally when requested by ENGINEER.
- D.      Roads or streets damaged by CONTRACTOR's operations, shall be repaired or removed and replaced to satisfactions of the agency having jurisdiction at no additional cost to the Project.
- E.      In order to insure adequate street maintenance and restoration as outlined above, CONTRACTOR may be required to deposit with the Agency having

## TEMPORARY FACILITIES AND CONTROLS

jurisdiction a cash Road Protection Bond.

1. This Bond, if required, will be held in escrow until final release is given by the Agency having jurisdiction. In the event CONTRACTOR fails or neglects to maintain or restore the streets to the satisfaction of the Agency having jurisdiction, the Agency having jurisdiction shall have the required maintenance or restoration work done and the cost incurred shall be deducted from the Road Protection Bond.
2. At the completion of the Project, the Agency having jurisdiction shall return the Road Protection Bond less any monies expended by the Agency having jurisdiction and shall render to CONTRACTOR an accounting of all monies so expended.

- F. CONTRACTOR shall not store any equipment, supplies, construction material or demolition debris on any roads or streets unless otherwise approved by ENGINEER.

### 1.4 EMERGENCY ACCESS

- A. CONTRACTOR shall provide emergency access to property in the vicinity of the construction for police vehicles, fire equipment, ambulances or other emergency vehicles to protect life, health and property. Any areas damaged by emergency vehicles shall be restored by CONTRACTOR at no additional cost to OWNER.

### 1.5 TEMPORARY ELECTRICITY AND LIGHTING

- A. CONTRACTOR shall be responsible for and pay all costs for the installation and removal of circuit and branch wiring, with area distribution boxes located so that power and lighting is available throughout the construction by the use of construction-type power cords and shall pay all costs of electrical power used.
- B. Electrical wiring and distribution shall conform to the National Electrical Code as adopted by the State of Kentucky.

### 1.6 TELEPHONE

- A. CONTRACTOR is required to provide telephone service for contacting emergency services. Such emergency telephone service shall also be available for the use of OWNER and ENGINEER whether or not a field office is required for the Project. Emergency phone numbers are required to be posted and copies provided to OWNER and ENGINEER.
- B. CONTRACTOR shall pay all costs for installation, maintenance and removal, and service charges for local calls to provide service for his construction site office. Toll charges for calls relating to Project business shall be at CONTRACTOR'S expense.

### 1.7 USE OF WATER

- A. The project site does not have potable water available. CONTRACTOR shall furnish a supply of potable water available for use of construction personnel

## TEMPORARY FACILITIES AND CONTROLS

including OWNER and ENGINEER.

- B. CONTRACTOR shall acquire any and all permits, post any bonds and pay all fees required by the local agency having jurisdiction prior to using hydrants or any other source of water.
- C. CONTRACTOR shall reimburse OWNER for water consumed during course of the Project at the current rate as set by the agency having jurisdiction, unless other arrangements are made with OWNER.

### 1.8 SANITARY PROVISIONS

- A. The project site does not have sanitary facilities available.
- B. CONTRACTOR shall be responsible for installation, maintenance and removal of temporary sanitary facilities for use of construction personnel including OWNER and ENGINEER. All rules and regulations of the State and local health officials shall be observed, with precautions taken to avoid creating unsanitary conditions.

### 1.9 MEDICAL SERVICES AND FIRST AID

- A. CONTRACTOR shall furnish first aid supplies and a person trained in first aid with a valid first aid certificate available for use of construction personnel including OWNER and ENGINEER. CONTRACTOR shall also furnish a communication system for contacting emergency services. Telephone numbers of the physician, hospital, or emergency services shall be conspicuously posted at the job site.

### **PART 2      PRODUCTS (NOT USED)**

### **PART 3      EXECUTION (NOT USED)**

END OF SECTION

**TEMPORARY FACILITIES AND CONTROLS**

**THIS PAGE LEFT BLANK INTENTIONALLY**



**SECTION 01 60 00**  
**PRODUCT REQUIREMENTS**

**PART 1**      **GENERAL**

1.1      TRANSPORTATION AND HANDLING

- A.      CONTRACTOR shall provide for expeditious transportation and delivery of materials and equipment to the Project site in an undamaged condition and on a schedule to avoid delay of the Work. Materials and equipment shall be delivered in original containers or packaging with identifying labels intact and legible.
- B.      CONTRACTOR shall provide equipment and personnel at the site to unload and handle materials and equipment in a manner to avoid damage. Materials and equipment shall be handled only at designated lifting points by methods to prevent bending or overstressing.

1.2      STORAGE AND PROTECTION

- A.      CONTRACTOR shall store materials and equipment immediately on delivery, and protect it until installed in the Work.
- B.      Products subject to damage by elements shall be stored in weather-tight enclosures with temperature and humidity ranges as required by manufacturer's instructions. The boiler room area within the ORPS2 facility may be available for the storage of some materials. CONTRACTOR to make written request of OWNER before bringing materials and/or equipment into the building.
- C.      Loose granular materials shall be stored on solid surfaces to prevent mixing with foreign matter.
- D.      The place of storage shall be located so as to minimize interference with traffic and to provide easy access for inspection. No material shall be stored closer than five (5) feet (1.5 m) to the edge of a pavement or traveled way open to the public.
- E.      Materials that have been stored shall be subject to retest and shall meet the requirements of their respective specifications at the time they are to be used in the Work.
- F.      CONTRACTOR shall provide protection of stored or installed materials and equipment as necessary to prevent damage from traffic and subsequent operations.
- G.      Location of staging and storage areas will be developed and coordinated with OWNER so that the location of these areas do not interfere with the daily operations of OWNER's facilities.

1.3      MANUFACTURER'S INSTRUCTIONS

- A.      When the Contract Documents require that installation of Work shall comply with

## PRODUCT REQUIREMENTS

manufacturer's instructions, CONTRACTOR shall obtain and distribute copies of such instructions to parties involved in the installation including two (2) copies to ENGINEER. CONTRACTOR shall handle, install, connect, clean, condition and adjust products in strict accord with such instructions and in conformity with specified requirements. Should Project conditions or specified requirements conflict with manufacturer's instructions, consult with ENGINEER for further instructions.

### 1.4 PRODUCTS LIST

- A. Within four (4) days of request, CONTRACTOR shall submit a complete list of major products proposed to be used, with the name of the manufacturer and the installing subcontractor, if applicable, to ENGINEER.

### 1.5 CONTRACTOR'S PRODUCT OPTIONS

- A. For products specified only by reference standard, CONTRACTOR shall select any product meeting that standard.
- B. For products specified by naming several products or manufacturer's CONTRACTOR shall select any one of the products or manufacturers named, which complies with the specifications.
- C. For products specified by naming one or more products or manufacturers and "or equal," CONTRACTOR must submit a Substitution Request Form for any product or manufacturer not specifically named, in accordance with paragraph 6.04 of the General Conditions.
- D. For products specified by naming only one product and manufacturer, there is no option.

### 1.6 EQUIPMENT STARTUP AND TESTING

- A. CONTRACTOR shall perform a comprehensive startup and demonstration of equipment performance and compliance with the design requirements. When there is more than one mode of operation, the equipment shall be operated in every mode to verify proper operation.
- B. When equipment is to operate in conjunction with other equipment as a system, each piece of equipment shall be operated both by itself and automatically as a system to verify its proper operation.
- C. CONTRACTOR is to provide to ENGINEER, in advance of startup, a schedule and listing of startup and testing procedures for review by ENGINEER. Checklists and diagrams may be required to ensure adequate startup and testing. ENGINEER may recommend changes to the startup procedure as necessary.
- D. Equipment is to be inspected prior to operation for debris or other obstructions.

Equipment is to be properly lubricated and calibrated prior to operation. CONTRACTOR shall make all adjustments necessary to assure correct operation. When required, equipment installation and operation is to be witnessed and checked by manufacturer.

- E. When required, CONTRACTOR shall train OWNER's operation and maintenance personnel in the proper operation and maintenance of each piece of equipment and the system as a whole. Training for an individual piece of equipment shall be a minimum of four (4) hours classroom and four (4) hours in the field at the device. All equipment to be fully functional, tested, and startup completed prior to training. Training time to be independent of startup and testing.
- F. Equipment startup is to be witnessed by OWNER and ENGINEER.

**PART 2**      **PRODUCTS (NOT USED)**

**PART 3**      **EXECUTION (NOT USED)**

END OF SECTION

**PRODUCT REQUIREMENTS**

**THIS PAGE INTENTIONALLY LEFT BLANK**

**SECTION 01 7700  
CLOSEOUT PROCEDURES**

**PART 1      GENERAL**

1.1    CLEANING

- A.    CONTRACTOR shall perform periodic cleaning to keep the Work, the site and adjacent properties free from accumulations of waste materials, rubbish and wind-blown debris, resulting from construction operations.
- B.    Waste material, debris and rubbish shall be periodically removed from the site and disposed of at legal disposal areas away from the site.
- C.    Prior to OWNER acceptance CONTRACTOR shall conduct an inspection of sight-exposed interior and exterior surfaces, and all Work areas, to verify that the entire Work is clean.
- D.    CONTRACTOR shall broom clean exterior paved surfaces and rake clean other exterior surfaces of the site.

1.2    PROJECT RECORD DOCUMENTS

- A.    CONTRACTOR shall deliver one (1) copy of all Specifications, Plans, Addenda, Shop Drawings and Samples, annotated to show all changes made during the construction process, to ENGINEER upon completion of the Work. Submittal of the record documents shall be made with a transmittal letter containing:
  - 1.    Date
  - 2.    Project Title and Number
  - 3.    CONTRACTOR's Name and Address
  - 4.    Title and Number of each Record Document
  - 5.    Certification that each Document as submitted is complete and accurate
  - 6.    Documents shall be submitted in good order and in a legible condition.

1.3    OPERATION AND MAINTENANCE DATA

- A.    Prior to final inspection or acceptance, CONTRACTOR shall fully instruct OWNER's designated operating and maintenance personnel in the operation, adjustment and maintenance of all products, equipment and systems specified. Training to occur after all equipment has been tested and completely operational. Training will not occur for equipment not accepted by the OWNER and/or ENGINEER as being ready for intended use.
- B.    Operation and maintenance data required by the individual Specification sections and the manufacturer's operation and maintenance data required in Section 01 3300, Submittal Procedures, shall constitute the basis of such instruction. Operation and Maintenance manuals shall be approved through the Submittal Procedures prior to startup, testing and training. Equipment without approved O&M documentation will not be ready for startup.

## **CLOSEOUT PROCEDURES**

### 1.4 START UP

- A. CONTRACTOR shall coordinate efforts between OWNER, ENGINEER, any equipment manufacturers, subcontractors and governing agencies in the start up of applicable portions of the Work.

### 1.5 SUBSTANTIAL COMPLETION

- A. Certification that the Work is substantially complete shall be in accordance with paragraph 14.07 of the General Conditions.

### 1.6 FINAL PAYMENT AND ACCEPTANCE

- A. The final inspection, final application for payment and acceptance shall be in accordance with paragraphs 14.09 thru 14.13 of the General Conditions.

### **PART 2      PRODUCTS (NOT USED)**

### **PART 3      EXECUTION (NOT USED)**

END OF SECTION

**DIVISION 02**  
**EXISTING CONDITIONS**

**THIS PAGE LEFT BLANK INTENTIONALLY**



**SECTION 02 4000  
DEMOLITION**

**PART 1   GENERAL**

1.1    DESCRIPTION SCOPE:

1.    CONTRACTOR shall provide all labor, materials, equipment and incidentals as shown, specified and required for demolitions, removal and disposal Work.

1.2    QUALITY ASSURANCE

- A.    Reference Standards: Comply with the latest edition of the applicable provisions and recommendations of the following, except as otherwise shown or specified:
  1.    Reinforcing Steel Welding Code, AWS D12.1.

1.3    SUBMITTALS

- A.    Schedule: Comply with Section 01 3300, Submittals, and the additional requirements below: Submit for approval proposed methods, equipment, and operating sequences. Include coordination for shut-off, capping, temporary services, continuation of utility services, and other applicable items to ensure no interruption of OWNER's operations.

1.4    JOB CONDITIONS

- A.    The CONTRACTOR shall carefully coordinate the work in areas where existing facilities are interconnected with new facilities and where existing facilities shall remain operational. The work indicated in the Contract Documents is not all inclusive and the CONTRACTOR shall be responsible to perform the reconstruction indicated plus that which can be reasonably inferred from the Contract Documents as necessary to complete the Project. The Specifications and Drawings identify the major facilities that shall be demolished and reconstructed, but auxiliary utilities such as water, air, chemicals, drainage, lubrication, fluid power, electrical wiring, controls, and instrumentation are not necessarily shown.
- B.    The CONTRACTOR shall note that the Drawings used to indicate demolition and reconstruction are based on record drawings of the existing facilities which have been reproduced to show existing conditions and to clarify the scope of work as much as possible. Prior to bidding the CONTRACTOR shall conduct a comprehensive survey at the Site to verify the correctness and exactness of the Drawings, the scope of work, and the extent of auxiliary utilities.

## **DEMOLITION**

- C. While demolition and reconstruction are being performed, the CONTRACTOR shall provide adequate access for the continued operation and maintenance of equipment. The CONTRACTOR shall erect and maintain fences, warning signs, barricades, and other devices around the reconstruction as required for the protection of the CONTRACTOR's employees and the OWNER's personnel at the plant. The CONTRACTOR shall remove all such protection when reconstruction activities are complete, or as work progresses, or when directed by the ENGINEER.
- D. Protection:
1. Perform all demolition and removal Work to prevent damage or injury to structures, occupants thereof and adjacent features which might result from falling debris or other causes, and so as not to interfere with the use, and free and safe passage to and from adjacent structures.
  2. Closing or obstructing of roadways, sidewalks, and passageways adjacent to the Work by the placement or storage of materials will not be permitted, and all operations shall be conducted with a minimum interference to traffic on these ways.
  3. Erect and maintain barriers, lights, sidewalk sheds, and other necessary protective devices.
  4. Repair damage to facilities to remain, or to any property belonging to the OWNER or occupants of the facilities.
- E. Scheduling:
1. Carry out operations so as to avoid interference with OWNER's operations and work in the existing facilities.
- F. Notification:
1. At least 48 hours prior to commencement of a demolition or removal, notify ENGINEER in writing of proposed schedule therefor. OWNER will inspect the existing equipment and mark for identification those items which are to remain the property of the OWNER. Do not start removals without the permission of the ENGINEER.
- G. Explosives:
1. Do not bring explosives onto site.
  2. The use of explosives will not be permitted.

## **PART 2 PRODUCTS**

(Part 2 omitted for this Section)

## **PART 3 EXECUTION**

### **3.1 GENERAL**

- A. The CONTRACTOR shall coordinate demolition and reconstruction work with the OWNER and ENGINEER. Unless otherwise indicated, the CONTRACTOR shall be responsible for the sequence of activities. Work shall be performed in accordance with applicable safety rules and regulations.

## DEMOLITION

02 4000-3

NKW2001.01H

- B. The CONTRACTOR shall verify that any utilities connected to structures, equipment, and facilities to be removed, relocated, salvaged, replaced, or abandoned are rendered inoperable, replaced with new utilities, or adequately bypassed with temporary utilities before proceeding with demolition and reconstruction.
- C. The CONTRACTOR shall take precautions to avoid damage to adjacent facilities and to limit the work activities to the extent indicated. If reconstruction beyond the scope indicated is required, the CONTRACTOR shall obtain approval from the ENGINEER prior to commencing work.
- D. Persons shall be afforded safe passages around areas of demolition.
- E. All materials and equipment removed from existing work shall become the property of CONTRACTOR, except for those which OWNER has identified and marked for his use. All materials and equipment marked by the OWNER to remain his shall be carefully removed by the CONTRACTOR, so as not to be damaged, and shall be cleaned and stored on or adjacent to the site in a protected place specified by the ENGINEER or loaded onto trucks provided by the OWNER.
- F. CONTRACTOR shall dispose of all demolition materials, equipment, debris, and all other items not marked by the OWNER to remain, off of the site and in conformance with all existing applicable laws and regulations. No demolition debris shall be disposed of within the Ohio River, including removed mortar and block.
- G. Surfaces of walls, floors, ceilings, or other areas which are exposed by any of the removals specified herein, and which will remain as architecturally finished surfaces shall be repaired and re-finished by the CONTRACTOR with the same or matching materials as the existing adjacent surface or as may be otherwise approved by the ENGINEER.
- H. Pollution Controls: Use water sprinkling, temporary enclosures, and other suitable methods to limit the amount of dust and dirt rising and scattering in the air to the lowest practical level. Comply with governing regulations pertaining to environmental protection.
  - 1. Do not use water when it may create hazardous or objectionable conditions such as ice, flooding, and pollution.
  - 2. Clean adjacent structures, facilities, and improvements of dust, dirt, and debris caused by demolition operations. Return adjacent areas to conditions existing prior to the start of the Work.
- I. Building Demolition:

## DEMOLITION

1. Unless otherwise approved by ENGINEER, proceed with demolition from the top of the structure towards the water/ground. Complete demolition work above each floor or tier before disturbing supporting members of lower levels.
2. Demolish concrete and masonry in small sections.
3. Remove structural framing members and lower to ground by means of hoists, derricks, or other suitable methods.
4. Break up and remove foundations and slabs-on-grade, unless otherwise shown to remain.
5. Locate equipment used for demolition work, and remove demolished materials, so as to not impose excessive loads on supporting walls, floors or framing.

### 3.2 ASBESTOS CONTAINING MATERIALS

- A. The existing structure has some asbestos containing materials (ACM) present. A report of materials tested for asbestos is included in Appendix A. Based on the extent of the new work, it is not anticipated to remove any known ACM identified by those testing results.
- B. The OWNER indicated there may be additional ACM present within the oxidizer containment area in the form of vinyl floor tiles. The CONTRACTOR shall submit notification to the Kentucky Division for Air Quality for asbestos demolition. A Kentucky licensed asbestos removal contractor shall perform the removal.

### 3.3 LEAD BASED PAINT MATERIALS

- A. The existing structure has some lead based paint (LBP) present. A report of the paint materials tested for lead is included in Appendix A. Based on the extent of the new work, the existing windows are known to have LBP present.
- B. CONTRACTOR shall utilize personnel trained in the correct handling and disposal of LBP materials.

### 3.4 STRUCTURAL REMOVALS

- A. Structural elements shall not be overloaded. The CONTRACTOR shall be responsible for shoring, bracing, or adding new supports as may be required for adequate structural support as a result of work performed under this Section. The CONTRACTOR shall remove all temporary protection when the work is complete.
- B. The CONTRACTOR shall carefully consider bearing loads and capacities before placement of equipment and material on Site. In the event of any questions as to whether an area to be loaded has adequate bearing capacity, the CONTRACTOR shall consult with the ENGINEER prior to the placement of such equipment or material.

## DEMOLITION

02 4000-5

NKW2001.01H

- C. Remove structures to the lines and grades shown unless otherwise directed by the ENGINEER. Where no limits are shown, the limits shall be 4 inches outside the item to be installed. The removal of masonry beyond these limits shall be at the CONTRACTOR'S expense and these excess removals shall be reconstructed to the satisfaction of the ENGINEER with no additional compensation to the CONTRACTOR.
- D. All concrete, brick, tile, concrete block, roofing materials, reinforcement, structural or miscellaneous metals, plaster, wire mesh and other items contained in or upon the structure shall be removed and taken from the site, unless otherwise approved by the ENGINEER. Demolished items shall not be used in backfill adjacent to structures or in pipe line trenches.
- E. After removal of parts or all of masonry walls, slabs and like work which tie into new Work or existing work, the point of junction shall be neatly repaired so as to leave only finished edges and surface exposed.
- F. The jambs, sills and heads of any new windows, passageways, doors, or other openings cut into new Work, or existing work, shall be dressed with new masonry, concrete or metal to provide a smooth, finished appearance.
- G. Where new anchoring materials including bolts, nuts, hangers, welds and reinforcing steel, are required to attach new Work to the existing work they shall be included under this Section, except where specified elsewhere.

### 3.5 MECHANICAL REMOVALS

- A. Mechanical removals shall consist of dismantling and removing of existing piping, motors, equipment and other appurtenances as specified, shown, or required for the completion of the Work. It shall include cutting, capping, and plugging as required.
- B. Existing process, water, chemical, gas, fuel oil and other piping not required for the new Work shall be removed where shown or where it will interfere with new Work. Piping not indicated to be removed or which does not interfere with new Work shall be removed to the nearest solid support, capped and left in place. Chemical and fuel lines shall be purged and made safe prior to removal or capping. Where piping that is to be removed passes through existing walls, it shall be cut off and properly capped on each side of the wall.

### 3.6 ELECTRICAL REMOVALS

- A. Electrical removals shall consist of the removal of existing motors, conduits and wires, lighting fixtures, and miscellaneous electrical equipment all as shown, specified, or required to perform the Work.

NKW2001.01H  
06/09/2016

02 4000-5

## DEMOLITION

- B. All existing electrical equipment and fixtures to be removed shall be removed with such care as may be required to prevent unnecessary damage, to keep existing systems in operation and to keep the integrity of the grounding systems.
- C. Motors shall be disconnected and removed where shown or specified. Motors not designated by the OWNER to be salvaged shall be removed from the site. Motors or other electrical gear designated for reuse shall be stored in enclosed, heated storage.
- D. Conduits and wires shall be abandoned or removed where shown. All wires in abandoned conduits shall be removed, salvaged, and stored. Abandoned conduits concealed in floor or ceiling slabs, or in walls, shall be cut flush with the slab or wall at the point of entrance. The conduits shall be suitably plugged and the area repaired in a flush, smooth, approved manner. Exposed conduits and their supports shall be disassembled and removed from the site. Repair all areas of work to prevent rust spots on exposed surfaces.
- E. Lighting fixtures shall be removed or relocated as shown. Fixtures not relocated shall be removed from the site. Relocated fixtures shall be carefully removed from their present location and rehung where shown.
- F. Wall switches, receptacles, starters and other miscellaneous electrical equipment, shall be removed and disposed of off the site as required. Care shall be taken in removing all equipment so as to minimize damage to architectural and structural members. Any damage incurred shall be repaired.

### 3.7 ALTERATIONS AND CLOSURES

- A. Alterations shall conform to all applicable Specifications, the Drawings, and the directions and approvals of the ENGINEER.
- B. Where alterations require cutting or drilling into existing floors, walls, and roofs, the holes shall be repaired in an approved manner. CONTRACTOR shall repair such openings with the same or matching materials as the existing floor, wall, or roof or as otherwise approved by the ENGINEER. All repairs shall be smoothly finished unless otherwise approved by the ENGINEER.
- C. Openings in existing concrete slabs, ceilings, masonry walls, floors and partitions shall be closed and sealed as shown or otherwise directed by the ENGINEER. New Work shall be keyed into the existing Work in an acceptable manner. New reinforcing steel shall be welded to the existing reinforcing. Welding shall conform to AWS D12.1, Reinforcing Steel Welding Code. In general, use the same or matching materials as the existing adjacent surface. The finished closure shall be a smooth, tight, sealed, permanent closure acceptable to the ENGINEER.

### 3.8 INSPECTION

## DEMOLITION

02 4000-7

NKW2001.01H

- A. CONTRACTOR shall examine demolition site, verify and observe conditions under which Work is to be performed and notify ENGINEER of unsatisfactory conditions. Do not proceed with the Work until unsatisfactory conditions have been corrected in a manner acceptable to ENGINEER.

### 3.9 CLEAN-UP

- A. Comply with Section 01 3543, Environmental Protection & Special Controls and the additional requirements below.
- B. CONTRACTOR shall remove from the site all debris resulting from the demolition operations as it accumulates. Upon completion of the Work, all materials, equipment, waste, and debris of every sort shall be removed and premises shall be left, clean, neat and orderly.

END OF SECTION

**DEMOLITION**

**THIS PAGE LEFT BLANK INTENTIONALLY**



**DIVISION 03**

**CONCRETE**

**THIS PAGE LEFT BLANK INTENTIONALLY**

**SECTION 03 11 00  
CONCRETE FORMING**

**PART 1      GENERAL**

1.1    SCOPE OF WORK

- A.    This Section includes formwork for cast-in-place concrete, complete with furnishing, preparation, installation, coating, protection, adjustment, removal and accessories.

1.2    RELATED WORK SPECIFIED ELSEWHERE

- A.    Section 03 1500: Concrete Accessories
- B.    Section 03 2000: Concrete Reinforcing
- C.    Section 03 3000: Cast-In-Place Concrete

1.3    DESIGN STANDARDS

- A.    Formwork shall be designed for the loads, lateral pressure, and allowable stresses outlined in "Recommended Practice for Concrete Formwork" ACI 347 and for design considerations, wind loads, allowable stresses and other applicable requirements of the local building code. Design and construction of the formwork shall be the responsibility of the CONTRACTOR.
- B.    Formwork shall be true in every respect to produce hardened concrete to the required shape, size, grade and alignment as indicated on the Plan, and of sufficient strength, bracing and rigidity to maintain their position and shape under the loads and operations incidental to placing and curing the concrete, as well as all other forces resulting from the movement of the forms. Limit panel deflection to 1/360 of exact component span to achieve tolerances specified.
- C.    Forms shall be mortar-tight at the time concrete is placed in them and shall be so constructed that the surfaces of the finished concrete will be reasonably free from ridges, fins, offsets, or similar defects.
- D.    Adequate and suitable means for removing the forms without injury to the surfaces or edges of the finished concrete shall be provided.

1.4    ALLOWABLE TOLERANCES

- A.    Formwork shall be constructed such that the hardened surfaces shall conform to the tolerance limits of ACI 347, except where more stringent tolerances are required below:
  - 1.    Variation from plumb in lines and surfaces of piers, walls, or columns:
    - a.    In any ten (10) feet (3 m) of length: 1/4 inch (5 mm)
    - b.    Maximum for entire length: 1-inch (25 mm)
  - 2.    Variation from the level or from the grades:

## CONCRETE FORMING

- a. In any ten (10) feet (3 m) of length: 1/4 inch (5 mm)
- b. Maximum for entire length: 3/4 inch (20 mm)
3. Variation of distance between walls, columns and beams:
  - a. In any ten (10) feet (3 m) of distance: 1/4 inch (5 mm)
  - b. Maximum for entire distance: 1-inch (25 mm)
4. Variation of the linear lines from established position as indicated on the Plans:
  - a. In any 20 feet (6 m) of length: 1/2 inch (10 mm)
  - b. Maximum for entire length: 1-inch (25 mm)
5. Variation in sizes and locations of sleeves, floor openings, and wall openings:
  - a. Minus: 1/4 inch (5 mm)
  - b. Plus: 1/2 inch (10 mm)
6. Variation in cross-sectional dimensions of columns and beams and thickness of slabs and walls:
  - a. Minus: 1/4 inch (5 mm)
  - b. Plus: 1/2 inch (10 mm)
7. Variations of footing dimensions from plan dimensions:
  - a. Minus: 1/2 inch (10 mm)
  - b. Plus: 2 inches (50 mm)
8. Thickness  $\pm$  5%, up to maximum of 1 inch (25 mm)

### 1.5 REFERENCE STANDARDS

- A. ACI - American Concrete Institute
- B. ASTM - ASTM International

### 1.6 SUBMITTALS

- A. Submit manufacturer's literature for form coating.
- B. Submit formwork layout plans, design data and procedures if requested by ENGINEER.

### 1.7 STORAGE AND HANDLING

- A. Store and handle form coating to prevent contamination of coating in accordance with manufacturer's recommendations.

### 1.8 SEQUENCING

- A. Sequence installation of formwork with the Work of Section 03 2000, Concrete Reinforcing; Section 03 1500, Concrete Accessories; and Section 03 3000, Cast-In-Place Concrete.

### 1.9 QUALIFICATIONS

## CONCRETE FORMING

- A. Formwork Designer: Formwork, falsework, and shoring design shall be performed by an engineer licensed in the State of Kentucky, with at least five years of experience designing similar systems.

### **PART 2**      **PRODUCTS**

#### 2.1      FORM MATERIALS

- A. Use lumber that is straight, uniform width and thickness, free from knots, offsets, holes, dents, warpage and other surface defects.
- B. Use plywood product of standard psi, waterproof, resin-bonded, exterior-type Douglas Fir, face adjacent to concrete shall be Grade B or better.
- C. Metal forms to be smooth metal plate free of surface irregularities.
- D. Chamfer Strips: Use clear white pine, surface against concrete planed, 1-inch (25 mm) bevel width or cant strip.
- E. Circular Columns: Fabricated steel or fiber reinforced plastic with bolted together sections or spirally wound fiber form internally treated with release agent for full height of column.

#### 2.2      FORM COATING

- A. Use nonstaining form oil or other mineral oil which will neither discolor nor otherwise injuriously affect the concrete.

#### 2.3      FORM TIES

- A. Use permanently embedded body type with removable end cones on outer ends, permanently embedded portion 1 ½ -inch (40 mm) back from concrete face.

#### 2.4      FORMS - GENERAL

- A. Use forms that conform to ACI 347. Fabricate with facing materials that produce the specified tolerance requirements of Article 1.4 of this Section; produce true surfaces, sharp corners and true lines; and are free of offsets, ridges, bulging, waves and concave or convex areas.

#### 2.5      LAYOUT

- A. Use regular and uniform pattern; long dimension of panels vertical; joints horizontal, vertical and aligned; form ties uniformly spaced and aligned in horizontal and vertical rows. Provide 4 foot x 8 foot panels or larger to reduce form seam lines, except where restricted by location of openings, joints or shape of structure.

## CONCRETE FORMING

### PART 3      EXECUTION

#### 3.1 PREPARATION

- A. Forms shall not be reused if there is any evidence of surface wear and tear or defects which would impair the quality of the surface. Surfaces of forms and embedded materials shall be cleaned of any mortar from previous concreting and of all other foreign material or water before coating is placed in them.
- B. Forms shall be coated in accordance with manufacturer's recommendations before the form or reinforcement is placed in final position. Surplus coating on form surfaces, or any coating on reinforcing steel and construction joints shall be removed before placing concrete.

#### 3.2 INSTALLATION OF FORMS

- A. Forms shall be sufficiently tight to prevent loss of mortar from the concrete, set true to the lines and elevations indicated on the Plans, tied and braced to remain true during and after concrete placement within tolerances of Article 1.4 of this Section. ENGINEER may at any time condemn any section or sections of forms found deficient in any respect, and such form shall be promptly removed and replaced.
- B. No wooden spreaders shall be allowed to remain in the concrete. No metal shall be within 1-inch (25 mm) of any surface.
- C. Place chamfer strips in forms to bevel all corners, edges, joints and other structural elements exposed to view, including use of dummy chamfer and false joints to provide neat and uniform appearance. Exposed corners and edges shall have 3/4" x 3/4" - 45 degree chamfers (20 mm x 20 mm x 45 degree), unless otherwise indicated on the Plan.
- D. Provide temporary openings at the base of wall forms and at the other points when necessary to facilitate cleaning and inspection immediately before depositing concrete.
- E. Secure in position wedges used for final alignment and items to be embedded in concrete.
- F. Forms for keyways shall be prepared in advance of pouring concrete. Keyway forms in slab edges and vertical wall joints shall be rigidly secured in place before the concrete is poured. Forms for keyways for horizontal joints in walls may be placed at the conclusion of the pour, but proper provision shall be made for obtaining and holding the full depth and form of the keyway. Raking, shoveling, or tooling in keyways is not acceptable.
- G. Provide openings and recesses and place sleeves in concrete as may be required and furnished by other sections of these specifications and as shown by all discipline drawings.

## CONCRETE FORMING

### 3.3 ADJUSTMENT OF FORMS

- A. Positive means of adjustment should be provided to permit realignment or readjustment of shores if excessive settlement occurs.
- B. A pair of wedges may be used at the top or bottom of shores, but not at both ends, to facilitate vertical adjustment, to correct uneven settlements, or to facilitate dismantling of the formwork.
- C. Screw jacks for pipe shores or scaffold-type shoring may be used at both top and bottom so long as they are secured by the shore or scaffold leg against loosening or falling out, to avoid lateral deflections.
- D. During and after concreting, but before initial set of the concrete, the elevations, camber, and plumbness of formwork systems shall be checked, using telltale devices. Appropriate adjustments shall be promptly made where necessary. If, during construction, any weakness develops and the formwork shows any undue settlement or distortion, the Work shall be stopped, the affected construction removed if permanently damaged, and the formwork strengthened.

### 3.4 REMOVAL OF FORMS

- A. Forms, wedges or shoring shall not be removed or disturbed until the concrete has attained sufficient strength to safely support superimposed dead, temporary construction, and live loads.
- B. When forms or shoring are removed, there shall be no excessive deflection or distortion of the concrete.
- C. Forms shall be removed in an orderly fashion; with care to avoid surface gouging, corner or edge breakage, or other damage or injury to the concrete surface or physical property; and without impact or shock, to permit the concrete to carry its share of the loads gradually and uniformly.
- D. Form removal shall not impair the safety and serviceability of the structure or concrete members.
- E. Forms and shoring in the formwork used to support the weight of concrete in beams, slabs, and other structural members shall remain in place a minimum of 14 days or until the concrete has reached a minimum of 80% of the design compressive strength. Cylinder strength shall be based on test specimens cured in the field, as described in ASTM C31, under conditions which are not more favorable than the most unfavorable conditions for the portions of the concrete which the test specimens represent and shall be determined in accordance with Section 03 3000, Cast-In-Place Concrete.
- F. Formwork for columns, walls and other vertical members shall remain in place a minimum of five (5) days or until the concrete has attained a minimum of 75% of its

## CONCRETE FORMING

design strength. Where such formwork also supports the formwork of beams and slabs, the removal times of the latter shall govern. Face and edge forms shall be removed as soon as practicable and permitted by ENGINEER in order to facilitate effective repair of voids or broken corners before the surface has dried.

- G. Forms and shoring in the formwork shall not be removed without the approval of ENGINEER. The minimum in-place times are for ordinary conditions and represent cumulative number of days, not necessarily consecutive, after the concrete was placed, during which the temperature of the air surrounding the concrete is above 50 degrees Fahrenheit (10 degrees Celsius). Times may be increased or decreased as directed by ENGINEER, dependent on air temperatures, cement type, concrete additives or other conditions of the Work in accordance with ACI 347.

### 3.5 RESHORING

- A. When removing forms before structural members are strong enough to carry dead load and/or construction loads, reshores shall be installed to assure safe distribution of loading. Reshoring operations shall be planned in advance and shall be subject to ENGINEER's review.
- B. During reshoring, no construction loads shall be permitted on the new construction.
- C. Reshores shall be placed as soon as practicable after form removal, but in no case later than the end of the working day on which form removal occurs, and shall remain in place until the concrete has acquired the required strength.

END OF SECTION



**SECTION 03 15 00  
CONCRETE ACCESSORIES**

**PART 1      GENERAL**

1.1    SCOPE OF WORK

- A.    This Section includes joint fillers, joint sealants, waterstops, and miscellaneous embedded items in concrete.

1.2    RELATED WORK SPECIFIED ELSEWHERE

- A.    Section 03 1100: Concrete Forming
- B.    Section 03 2000: Concrete Reinforcing
- C.    Section 03 3000: Cast-In-Place Concrete

1.3    REFERENCE STANDARDS

- A.    ASTM - American Society for Testing Materials
- B.    CRD - U.S. Army Corps of Engineers Handbook for Concrete and Cement Specifications

1.4    SUBMITTALS

- A.    Submit certified manufacturer's affidavits for expansion joint filler, joint sealant and waterstops to verify compliance with the applicable Specifications.
- B.    Submit a schedule of concrete pouring and indicate locations of proposed construction and expansion joints. Schedule is subject to approval of ENGINEER.

1.5    ENVIRONMENTAL REQUIREMENTS

- A.    Environmental requirements relative to temperature for placing joint sealants are specified in article 3.4 of this Section.

1.6    SEQUENCING

- A.    CONTRACTOR shall sequence installation of miscellaneous embedded items with the Work of Section 03 1100 Concrete Forming; Section 03 2000, Concrete Reinforcing; and Section 03 3000 Cast-In-Place Concrete.

## CONCRETE ACCESSORIES

### PART 2      Products

#### 2.1 JOINT FILLER

- A. Backup Material: ASTM D 1056, round closed cell foam rod, sized 30 to 50 percent larger than joint width.
- B. Prefomed Expansion Joint Filler for Concrete (Bituminous Type) ASTM D994.
- C. Prefomed Expansion Joint Fillers for Concrete Paving and Structural Construction (Nonextruding and Resilient Bituminous Types) ASTM D1751.
- D. Prefomed Sponge Rubber and Cork Expansion Joint Fillers for Concrete Paving and Structural Concrete ASTM D1752.

#### 2.2 JOINT SEALER

- A. Joint Primer: Two component, penetrating liquid resinous primer for use with urethane and epoxy sealants.
- B. Joint Sealants: Shall be a two component polyurethane, elastomeric sealant conforming to ASTM C 920, shall be SikaFlex – 2C, by SIKA Corporation, or approved equal. Sealant shall be capable of 50 percent joint movement. Use self leveling (SL) consistency for horizontal applications and non-sag (NS) consistency for vertical applications.

#### 2.3 WATERSTOPS

- A. Waterstops shall be of the size and type indicated on the plans and as specified.
- B. PVC waterstops shall conform to CRD-C572 polyvinyl chloride (PVC) or CRD-C513 styrene-butadiene rubber (SBR). Flat ribbed type (6" x 3/8") shall be used in joints in walls and slabs where shown on the plans. Center bulb type (9") shall be used in expansion joints
- C. Bentonite waterstops shall be flexible, specially formulated compound of sodium bentonite-butyl (1" x 3/4" min.) with manufacturer recommended adhesive. Bentonite waterstops shall be used in walls and slabs where indicated on the plans.
- D. Hydrophilic rubber waterstop shall be flexible, hydrophilic synthetic rubber, strip waterstop (1" x 3/4" min.) with manufacturer recommended adhesive. Hydrophilic rubber waterstops shall be used in joints in walls and slabs where indicated on the plans..

## CONCRETE ACCESSORIES

### 2.4 CONCRETE ANCHORS

- A. General:
1. Select type and size to achieve required loading capacity using information provided by manufacturer. Anchors shall be adhesive type unless otherwise indicated, or where not appropriate at anchor locations.
  2. Maintain critical edge distance and spacing per manufacturer's recommendations for all anchors. Provide tamper proof hardware when called for on the plans.
- B. Adhesive Anchors:
1. Adhesive anchoring system shall be HY-150 hybrid adhesive mortar (by Hilti, Inc. or approved equal) utilizing urethane resin, hardener, Portland cement and water. This adhesive system shall be used for all post installed anchors and reinforcing steel dowels into existing concrete.
  2. Threaded rod: Threaded rods shall be 316 stainless steel HAS rods (by Hilti, Inc. or approved equal) conforming to ASTM 593, CW. All nuts shall be stainless steel conforming to ASTM F594 and all washers shall conform to ANSI B18.22.1.
- C. Wedge Type Anchors:
1. One piece body with expansion mechanism installed in pre-drilled hole using matching tolerance bit.
  2. Carbon steel anchor body, washers, nuts and wedges, plated in accordance with ASTM B 633, SC1, Type III or Type 316 stainless steel anchor body, washers, nuts and wedges when so indicated on plans.
- D. Anchor Rods:
1. Anchor rods shall conform to ASTM F 1554 grade 36, unless otherwise noted on the drawings.
  2. All rotating equipment anchor rods shall be supplied with sleeves. These sleeves shall not be grouted but should be filled with an appropriate material and sealed to prevent water penetration.
  3. Vertical vessels with base rings and other equipment with cast bases or bed plates, Shall have anchor rods supplied with sleeves. These sleeves shall be filled with grout after setting the equipment in place.
  4. Use two nuts on anchor rods for towers, reciprocating pumps, compressors and other vibrating equipment.

## **PART 3**      **EXECUTION**

### 3.1 CONTRACTOR'S VERIFICATION

- A. Inspect the locations and surfaces to receive joint filler, joint sealer, waterstops, or miscellaneous embedded items and correct defects or conflicts which will affect the proper performance of the item to be placed.

## CONCRETE ACCESSORIES

### 3.2 PREPARATION

- A. Accessories to be embedded into concrete shall have contact surfaces free of dirt, curing compound, protrusions of hardened concrete or any other foreign material which would affect bond with concrete.
- B. Prime surfaces in accordance with manufacturer's recommendations.

### 3.3 INSTALLATION OF JOINT FILLERS

- A. Details, including materials and methods of installation of joint fillers shall be as indicated on the Plans and as approved by ENGINEER.

### 3.4 INSTALLATION OF JOINT SEALANTS

- A. Joints shall not be sealed when the sealant, air or concrete temperature is less than 40 degrees Fahrenheit (4 degrees Celsius). Bond breaker and backup material shall be installed where required as indicated on the Plans or manufacturer's recommendations.

### 3.5 INSTALLATION OF PVC WATERSTOPS

- A. Waterstops shall be of maximum practicable length to minimize joints.
- B. Waterstops shall be positioned as indicated on the Plans in a manner to permanently retain flexibility.
- C. Splice in length or at intersections shall be performed by heat sealing and in accordance with manufacturer's recommendations.
- D. Reform splices with a remolding iron with ribs or corrugations to match the pattern of the waterstop. When cooled and bent by hand in as sharp an angle as possible, the splice shall show no sign of separation.
- E. Provide support and protection of the waterstops during the progress of the work. Any waterstop punctured or damaged shall be replaced or repaired at CONTRACTOR's expense. Concrete shall be thoroughly consolidated in the vicinity of the waterstop. Suitable guards shall be provided to protect exposed projecting edges and ends of partially embedded waterstops from damage when concrete placement has been discontinued.

### 3.6 CONCRETE ANCHORS

- A. Do not begin installation until substrates have been properly prepared. Do not proceed with installation if substrate preparation is unsatisfactory.

## CONCRETE ACCESSORIES

- B. Clean surfaces thoroughly prior to installation. Prepare surfaces using the methods recommended by the manufacturer for achieving the best result for the substrate under the project conditions.
- C. Install in accordance with manufacturer's instructions and recommendations and as required by applicable code. Anchor applied items neatly, with item mounted plumb and level unless otherwise indicated.
- D. ENGINEER reserves the right to require the anchor manufacturer's representative to demonstrate proper installation procedures for post-installed anchors and to observe CONTRACTOR's installation procedures, at no extra cost to OWNER. ENGINEER reserves the right to require pullout or shear tests to determine adequacy of anchors, at no extra cost to OWNER.

### 3.7 MISCELLANEOUS EMBEDDED ITEMS

- A. Sleeves, inserts, anchor bolts, and other embedded items required for adjoining Work or for its support shall be placed prior to concreting.
- B. Embedded items shall be positioned accurately and supported against displacement. Voids in sleeves, inserts, and anchor slots shall be filled temporarily with readily removable material to prevent the entry of concrete into the voids.

END OF SECTION

**CONCRETE ACCESSORIES**

**THIS PAGE INTENTIONALLY LEFT BLANK**

**SECTION 03 20 00  
CONCRETE REINFORCING**

**PART 1      GENERAL**

1.1 SCOPE OF WORK

- A. This Section includes the furnishing, fabrication, placement and care of material used as concrete reinforcement.

1.2 RELATED WORK SPECIFIED ELSEWHERE

- A. Section 03 1100: Concrete Forming
- B. Section 03 1500: Concrete Accessories
- C. Section 03 3000: Cast-In-Place Concrete

1.3 REFERENCE SPECIFICATIONS

- A. The latest or current ACI Standards and Code Requirements for "Concrete and Reinforced Concrete" shall govern all concrete Work except where otherwise specified herein. Copies of standards can be obtained from the American Concrete Institute.

1.4 TESTING AGENCY

- A. Testing agencies shall meet the requirements of Recommended Practice for Inspection and Testing Agencies for Concrete, Steel and Bituminous Materials as Used in Construction, ASTM E329.

1.5 ALLOWABLE TOLERANCES

- A. Fabrication:
  - 1. Sheared length:  $\pm 1$ -inch (25 mm).
  - 2. Depth of truss bars: +0, -1/2 inch (+0, -10 mm).
  - 3. Stirrups, ties, and spirals:  $\pm 1/2$  inch ( $\pm 10$  mm)
  - 4. All other bends:  $\pm 1$ -inch ( $\pm 25$  mm).
- B. Placement:
  - 1. Concrete cover to form surfaces:  $\pm 1/4$  inch ( $\pm 5$  mm).
  - 2. Minimum spacing between bars: -1/4 inch (-5 mm).
  - 3. Top bars in slabs and beams:
    - a. Members eight (8) inches (200 mm) deep or less:  $\pm 1/4$  inch (5 mm).
    - b. Members more than eight (8) inches (200 mm) but not over two (2) feet (600 mm) deep:  $\pm 1/2$  inch ( $\pm 10$  mm).
    - c. Members more than two (2) feet (600 mm) deep:  $\pm 1$ -inch ( $\pm 25$  mm).
  - 4. Crosswise of members: Spaced evenly within two (2) inches (50 mm) of stated separation.

## CONCRETE REINFORCING

5. Lengthwise of members:  $\pm 2$  inches ( $\pm 50$  mm).
6. Maximum bar movement to avoid interference with other reinforcing steel, conduits, or embedded items: 1-bar diameter, with approval from ENGINEER.

### 1.6 SOURCE QUALITY CONTROL

- A. Reinforcing steel shall be subject to inspection at the source of supply, fabricator, or after delivery to the Project Site at the discretion of ENGINEER.
- B. CONTRACTOR may be required to furnish additional test of reinforcing steel for each 100 tons (90 metric ton) or fraction thereof. Testing for bend, pull, elongation and weight to assure compliance with Specifications shall be in accordance with ASTM A370.

### 1.7 REFERENCE STANDARDS

- A. ACI - American Concrete Institute
- B. ASTM – American Society for Testing Materials
- C. CRSI - Concrete Reinforcing Steel Institute

### 1.8 SUBMITTALS

- A. CONTRACTOR shall submit Shop Drawings indicating the size and dimensions for fabrication and placing of reinforcing steel, including bar schedules, stirrup spacing, and diameter of bend bars. Bar supports type and grade shall be indicated.
- B. CONTRACTOR shall submit shop and placement drawings indicating all construction and expansion joints. Shop drawings shall include pour sequence.
- C. CONTRACTOR shall submit test certificates of the manufacturer's laboratory, identifying chemical and physical analysis of each load of reinforcing steel delivered.
- D. CONTRACTOR shall submit test certificates of a qualified independent testing agency evaluation of the mechanical splice devices to assure compliance with ACI 318.

### 1.9 DELIVERY, STORAGE, AND HANDLING

- A. Deliver reinforcement to Project site in bundles tagged and marked in accordance with "Manual of Standard Practice" of the CRSI.
- B. Reinforcing steel shall be stored above ground on platforms or other supports, in an orderly manner to facilitate inspection and checking, and be protected from physical injuries or contamination.



## CONCRETE REINFORCING

### 1.10 SEQUENCING

- A. CONTRACTOR shall coordinate placement of the reinforcing in a manner which will not prevent the proper and timely completion of dependent construction phases.

## **PART 2**      **PRODUCTS**

### 2.1 REINFORCING BARS

- A. Reinforcement shall be of the grade and type as specified herein unless otherwise indicated on the Plans or Shop Drawing.
- B. Bars:
  - 1. Deformed and Plain Billet-Steel Bars: ASTM A615, Grade 60.
  - 2. Rail-Steel Deformed and Plain Bars: ASTM A616, Grade 60.
  - 3. Axle-Steel Deformed and Plain Bars: ASTM 617, Grade 60.
  - 4. Low Alloy Steel Deformed Bars: Bars to be welded shall conform to ASTM A706.
- C. Mats:
  - 1. Fabricated steel bar or rod mats of the clipped type shall conform to ASTM A184.

### 2.2 WELDED WIRE FABRIC

- A. Welded wire fabric shall be in flat mats only.
- B. Plain:
  - 1. Conform to ASTM A185, 6 x 6 – w2.9 x w2.9 unless otherwise indicated on the Plans.
- C. Deformed:
  - 1. Conform to ASTM A496, 6 x 6 – w2.9 x w2.9 unless otherwise indicated on the Plans.

### 2.3 TIE WIRE

- A. Plain:
  - 1. Conform to Cold Drawn Steel Wire for Concrete Reinforcement, ASTM A82, 16-gage minimum size.

## CONCRETE REINFORCING

- B. Deformed:
  - 1. Conform to Deformed Steel Wire for Concrete Reinforcement, ASTM A496, size D-4 minimum.

### 2.4 BAR SUPPORTS

- A. Metal bar supports shall be fabricated from cold-drawn steel wire in accordance with current CRSI Standards.
- B. Stainless steel supports shall be of Type 1, with stainless steel wire conforming to ASTM A493 attached to the tips of the support so the nonstainless wire will lie no closer than 1/4 inch (5 mm) from the form surface.
- C. Plastic coated supports shall be of Type 1, with plastic coating of polyethylene conforming to ASTM D1248 on the legs and tips.
- D. Precast concrete brick supports shall conform to ASTM C55, Type 1, Grade N.

### 2.5 FABRICATION

- A. Bars shall be bent cold to the shapes and dimensions as indicated on the Plans, or as required by the current "Manual of Standard Practice" of the CRSI. Steel shall not be bent or straightened in a manner that will injure the material. Bars with kinks or improper bends shall not be used.
- B. The diameter of bend measured on the inside of the bar for standard hooks, other than stirrups and tie hooks, shall not be less than the values of the following table.

Minimum Diameters of Bend	
Bar Size	Minimum Diameter
#3 through #8 (#10M - #25M)	6 bar diameters
#9, #10, and #11 (#29M - #36M)	8 bar diameters
#14 and #18 (#43M - #57M)	10 bar diameters

- C. Bends for stirrups and ties with number 5 (#16M) bar and smaller shall not be less than four bar diameters. For bars larger than No. 5 (#16M), bends shall be according to the "Minimum Diameter of Bend" table above.
- D. Bends for stirrups and ties for welded wire fabric shall not be less than 4-bar diameters for deformed wire larger than D-6 and 2-bar diameters for all other wires. Bends with inside diameter of less than 8-bar diameters shall not be less than 4-bar diameters from nearest welded intersection.

## CONCRETE REINFORCING

### **PART 3**      **EXECUTION**

#### 3.1 CONTRACTOR'S VERIFICATION

- A. CONTRACTOR shall examine the areas in which the reinforcing steel is to be placed to assure proper lines and levels.

#### 3.2 PREPARATION

- A. Remove dirt, grease, oil, loose mill scale, excessive rust, and foreign matter that will reduce bond with concrete or splicing method.
- B. The ends of bars to be butt spliced shall be cut square and smooth.

#### 3.3 INSTALLATION - GENERAL

- A. Reinforcing shall be placed as indicated on the approved Shop Drawings, within allowable tolerances. Bar supports, as indicated on approved Shop Drawings, or in Specifications, shall be used for proper separation and support of reinforcing steel.

#### 3.4 MINIMUM SPACING

- A. Unless otherwise indicated on the Plans, the minimum spacing of bars shall be the following:
- B. Footings and other principal structural members in which the concrete is deposited against the ground shall have three (3) inches (75 mm) of concrete between the bar and the ground contact surface.
- C. Concrete surfaces which, after removal of the forms, are to be exposed to the weather or in contact with the ground or liquids, shall be protected with two (2) inches (50 mm) of concrete.
- D. Concrete protective covering for any reinforcement at surfaces not exposed directly to the ground, liquids or weather shall be 3/4 inch (20 mm) for slabs and walls and 1-1/2 inches (40 mm) for beams and girders.
- E. Column spirals or ties shall be protected everywhere by a covering of concrete cast monolithically with the core and shall be at least 1-1/2 inches (40 mm).
- F. Concrete protection for reinforcement shall in all cases be at least equal to the diameter of bars, except for concrete slabs as noted above.
- G. Minimum center to center distance between parallel bars shall be 2-1/2 times the diameter of the bars. In no case shall the clear spacing between bars be less than one inch (25 mm) nor less than 1-1/3 times the maximum size of the coarse aggregate. The maximum center to center distance in parallel bars shall be 18

## CONCRETE REINFORCING

inches (450 mm). Where reinforcement in beams and girders is placed in two (2) or more layers, the clear distance between layers shall be not less than 1-inch (25 mm), and the bars in the upper layers shall be placed directly above those in the bottom layer.

- H. Welded wire fabric designated as load-carrying reinforcement shall be overlapped wherever successive mats are continuous in such a way that the overlap measured between outermost cross wires of each fabric sheet is not less than the spacing of the cross wires plus two (2) inches (50 mm). It shall be supported as required for reinforcing bars.

### 3.5 SPLICING

- A. Splices shall be avoided at points of maximum stress. Splicing of bars shall be in accordance with ACI 318.
- B. Splicing of bars shall be done by overlapping in accordance with ACI Detailing Manual SP-66, and securely laced with wire unless indicated otherwise on the Plans or approved Shop Drawing.
- C. Lap adjoining wire mesh by no less than one (1) full mesh and lace securely with wire. Offset end laps in adjacent widths to prevent continuous splice.
- D. Welded wire fabric reinforcement shall be overlapped wherever successive mats are continuous in such a way that the overlap measured between outermost cross wires of each fabric sheet is not less than one full mesh spacing plus two (2) inches (50 mm). The fabric shall extend across supporting beams and walls and to within four (4) inches (100 mm) of concrete edges. It may extend through contraction joints where alternate wires are field cut. It shall be adequately supported during placing of concrete to insure its proper position in the slab either by the methods of Article 3.06 of this Section or by laying the fabric on a layer of the fresh concrete of the correct depth before placing the upper layer of the slab.
- E. Vertical bars in columns shall be offset at least 1-bar diameter at lapped splices. To insure proper placement, templates shall be furnished for all column dowels.
- F. Bars of size 14, 18 or larger (#43M #57M or larger), where size 11 (#36M) bars are butt spliced to larger sizes and/or when approved by ENGINEER shall be welded in accordance with ACI 301 by full penetration butt welds. Adequate jigs and clamps or other devices shall be provided by CONTRACTOR to support, align and hold the longitudinal centerline of the bars in a straight line.
- G. Bars larger than size eleven (#36M) may be butt spliced by mechanical devices approved by ENGINEER, in accordance with ACI 318. Splices shall be made using manufacturer's standard jigs, clamps, ignition devices and other required accessories to support, align and hold the longitudinal centerline of the bars in a straight line.

## CONCRETE REINFORCING

### 3.6 SECURING REINFORCEMENT

- A. Reinforcement shall be securely laced with wire to supports or reinforcing to prevent displacement during the concrete placement, as required by the current "Manual of Standard Practice" of the CRSI.

### 3.7 FIELD QUALITY CONTROL

- A. ENGINEER shall inspect the reinforcing steel after it has been installed, and the reinforcing steel placement shall be approved by ENGINEER prior to placement of concrete.
- B. CONTRACTOR shall avoid displacement of the reinforcing steel during concrete placement.

END OF SECTION

**CONCRETE REINFORCING**

**THIS PAGE INTENTIONALLY LEFT BLANK**

**SECTION 03 30 00  
CAST-IN-PLACE CONCRETE**

**PART 1      GENERAL**

1.1 SCOPE OF WORK

- A. This Section includes all monolithic cast-in-place concrete work complete with materials, mixes, installation and testing.

1.2 RELATED WORK SPECIFIED ELSEWHERE

- A. Section 03 1100: Concrete Forming
- B. Section 03 1500: Concrete Accessories
- C. Section 03 2000: Concrete Reinforcing
- D. Section 05 5000: Metal Fabrications

1.3 REFERENCE STANDARDS

- A. Unless otherwise specified, the Work for this Section shall conform to the applicable portions of the latest version of the following Standard Specifications and Industry Standards:
  - 1. ASTM - ASTM International
  - 2. AASHTO - American Association of State Highways and Transportation Officials
  - 3. KTC - Kentucky Transportation Cabinet

1.4 REFERENCE SPECIFICATIONS AND CODES

- A. The latest or current ACI Standards and Code Requirements for "Concrete and Reinforced Concrete" shall govern all concrete Work except where otherwise specified herein.

1.5 DEFINITIONS

- A. Mass Concrete: All reinforced, cast-in-place concrete elements exceeding 2'-6" in thickness shall be treated as reinforced mass concrete. The mix design selection and installation of all mass concrete shall conform to the requirements of Section 8 – Mass Concrete, in ACI 301 – Standard Specification for Structural Concrete.

1.6 ALLOWABLE TOLERANCES

- A. See Section 03 1100, Concrete Forming, for the allowable tolerances for concrete surfaces.

## CAST-IN-PLACE CONCRETE

### 1.7 DESIGN CRITERIA

- A. Mixes shall be designed and tested for each size and gradation of aggregates and for each consistency intended for use. Design quantities and test results of each mix shall be submitted for review.
- B. Necessary construction joints are shown on the Plans. Modification of location or placement of construction joints not indicated on the Plans shall be subject to approval of ENGINEER. In general, they shall be located within the middle one-third of the span of slabs, beams, and girders unless a beam intersects a girder at this point, in which case the joint in the girder shall be offset a distance equal to twice the width of the beam.
- C. Joints in walls and columns shall be at the underside of floors, slabs, beams, or girders and at the tops of footings or floor slabs. Beams, girders, brackets, column capitals, haunches, and drop panels shall be placed at the same time as slabs. Joints shall be perpendicular to the main reinforcement.
- D. Keyways shall be provided in all joints where required to provide for either shear or watertightness. Unless otherwise required, the width of keys shall be at least one-third the thickness of the section at that point and their depth at least one-third their width.

### 1.8 SOURCE QUALITY ASSURANCE

- A. All inspections and tests required by this section shall be performed by an independent laboratory acceptable to the ENGINEER.
- B. Testing shall be in accordance with applicable ASTM Standards to assure compliance with Specifications.
- C. Furnish tests of cement and aggregates. Material sampling shall conform to the following ASTM Standards:
  - 1. Cement - C183.
  - 2. Aggregates - D75.
- D. Make tests for the following quantities, or fraction thereof:
  - 1. Cement .....550 tons (500 metric ton)
  - 2. Fine Aggregate .....2,000 Tons (1800 metric ton)
  - 3. Coarse Aggregate .....2,000 Tons (1800 metric ton)
- E. Use same brand cement for any given structure produced by a single mill unless otherwise provided by authorization of the ENGINEER.
- F. OWNER reserves the right to make inspections at any time at the source of supply of materials, at the place of preparation of materials or at the mixing plant if ready-mixed concrete is used.



## CAST-IN-PLACE CONCRETE

### 1.9 SUBMITTALS

- A. Submit Concrete Placement Drawings showing the sequence of placement and the location of joints. Included shall be a schedule of the concrete pouring. Location of joints and pouring schedule shall be subject to approval by ENGINEER.
- B. CONTRACTOR shall submit test reports for cement and aggregates to assure compliance with the Specifications.
- C. Concrete mixture designs and test data shall be submitted for review by ENGINEER with a written request for approval. No concrete shall be placed until CONTRACTOR has received such approval in writing.
  - 1. Each mixture report shall include:
    - a. Slump on which design is based.
    - b. Total gallons of water per cubic yard ( $l/m^3$ ).
    - c. Brand, type, composition, and quantity of cement.
    - d. Brand, type, composition, and quantity of pozzolan or other mineral admixtures.
    - e. Brand, type, composition, and quantity of ground granulated blast furnace slag.
    - f. Specific gravity and gradation of each aggregate.
    - g. Ratio of fine to total aggregates.
    - h. Weight (surface dry) of each aggregate, lbs./c.y. ( $kg/m^3$ ).
    - i. Brand, type, ASTM designation, active chemical ingredients, and quantity of each admixture.
    - j. Air content.
    - k. Compressive strength based on 7-day and 28-day compression tests.
    - l. Time of initial set.
    - m. Water/Cement ratio.
- D. Submit manufacturer's literature of abrasive wear resistant floor finish and of chemical curing compound for review by ENGINEER.
- E. Submit a sample concrete delivery ticket for review by ENGINEER.
- F. Submit tickets collected at the site of concrete placement accompanying each load of concrete. A printout system for producing these tickets in connection with automatic batching will be permitted.
- G. Each ticket shall be serially numbered, show the charging time, quantity and grade of concrete, location of delivery and the signatures of inspectors at the plant and site. Transit mixed concrete tickets shall also include revolution counter reading at charging and mixing completion.
- H. Submit reports of the sampling and testing of slump, air content and strength performed.

## **CAST-IN-PLACE CONCRETE**

- I. Submit reports of nondestructive, core and/or liquid retention testing required for acceptance of concrete in place.

### **1.10 MATERIAL STORAGE AND HANDLING**

- A. Materials shall be stored and handled in accordance with ACI 304 and as specified below.
- B. When permission is given to store cement in the open, a floor at least six (6) inches (150 mm) above the ground and a waterproof covering shall be provided and so placed as to insure runoff in case of rain.
- C. Cement sacks shall be thoroughly shaken when emptying sacks into the batch. Cement salvaged by CONTRACTOR by cleaning sacks mechanically or otherwise, or from discarded sacks of cement, shall not be used in the Work.
  1. The use of a fractional sack of cement will not be permitted unless the fractional part is measured by weight.
  2. At the time of its use in the Work, the cement shall be free from lumps.
- D. No aggregates which have become intermixed prior to proportioning shall be used. Sufficient aggregate shall be available at the site to preclude the possibility of damaging delays while placing the concrete.
- E. Cars used for shipping aggregates shall be clean and in good repair.
  1. The use of straw, marsh, hay or other similar materials for closing cracks or holes in cars will not be tolerated.
- F. Pozzolans and other cementitious materials shall be stored and handled in the manner of cement.
- G. Store and handle curing compound in a manner to prevent contamination.

### **1.11 ENVIRONMENTAL REQUIREMENTS**

- A. Environmental requirements shall be in accordance with ACI 305 for hot weather concreting, and ACI 306 for cold weather concreting.
  1. Specific temperature requirements are contained in Article 2.10 of this Section for mixing and Article 3.13 of this Section for placing.

## **PART 2      PRODUCTS**

### **2.1 GENERAL**

- A. The materials shall meet the requirements of ACI 301, ACI 318, ASTM C33, and KTC.

## CAST-IN-PLACE CONCRETE

- B. Concrete materials shall be tested and inspected as the Work progresses. The review and/or check-test of the proposed materials, securing of production samples of materials at plant stockpiles and/or review of the manufacturer's reports for compliance will be performed at no cost to CONTRACTOR.
- C. Testing and inspection required due to substitution or change of materials requested by CONTRACTOR shall be at CONTRACTOR's expense.

### 2.2 CEMENT

- A. Cement shall be the type as indicated on the Plans or as specified:
  - 1. Type I and IA, conforming to ASTM C150, air-entraining Portland cement when special properties are not specified.
  - 2. Type III and IIIA, conforming to ASTM C150, air-entraining Portland cement for use when high-early strength is specified.
  - 3. Type IS and IS-A, conforming to ASTM C595, air-entraining Portland blast-furnace slag cement for use in general concrete construction.
  - 4. Type IP and IP-A, conforming to ASTM C595, air-entraining Portland-Pozzolan cement for use in general construction. The addition of suffix (MS) signifies that moderate sulfate resistance is specified. The addition of suffix (MH) signifies that moderate heat of hydration is specified.

### 2.3 AGGREGATES

- A. Washing will be required to eliminate the dust, clay, or silt coating. Aggregates which have been washed shall not be used sooner than 24 hours after washing, unless approved by the DESIGN PROFESSIONAL.
- B. Coarse aggregate shall be gravel or crushed rock, conforming to ASTM C33.
- C. Gravel shall consist of hard, clean, durable particles of rock or pebbles and shall be free from lumps of clay.
- D. Crushed rock shall consist of angular fragments of crushed hard heads or boulders or crushed igneous rock free from weathered rock and of uniform quality.
- E. All sieve and screen analyses determination of clay, silt, and dust content and percentages of objectionable particles will be based on dry weights and conform to KTC Specifications, Standard sizes of coarse aggregate and shall conform to the physical requirements specified in KTC Specifications.
- F. Fine aggregate shall be natural sand, manufactured sand or a combination thereof conforming to ASTM C33.

## CAST-IN-PLACE CONCRETE

- G. Fine aggregates shall conform to KTC Specifications and to the grading requirements stated therein.

### 2.4 ADMIXTURES

- A. Admixtures shall be used to achieve concrete as indicated on the Plans or specified herein. Calcium chloride shall not be used.
  - 1. Air-entraining, conforming to ASTM C260.
  - 2. Pozzolan and Fly Ash, conforming to ASTM C618, Class C or F.
  - 3. Water reducing, conforming to ASTM C494.
  - 4. Retarder, conforming to ASTM C494.
  - 5. Plasticizer, conforming to ASTM C494.
  - 6. Ground granulated blast furnace slag conforming to ASTM C989, grade 100.
- B. Abrasive wear resistant floor finish shall be packaged, dry combination of Portland cement, graded Quartz aggregate and dispersing agents formulated to produce an abrasive and wear resistant monolithic surface.

### 2.5 JOINT FILLER

- A. See Section 03 1500, Concrete Accessories.

### 2.6 WATER

- A. Water shall be free from oil, acid, alkali, organic matter, and any other deleterious substances.

### 2.7 CURING COMPOUND

- A. Shall be adequate to prevent checking, cracking and loss of moisture, conforming to ASTM C309.

### 2.8 MIXES

- A. Concrete shall consist of a mixture of air-entraining Portland cement, coarse and fine aggregate, and water with admixtures if required.
  - 1. Admixtures shall not be used without ENGINEER's review.
  - 2. The mixture, combined in proportions, shall meet the requirements of KTC, and ACI 211.1.
- B. Concrete shall be classified and proportioned on the basis of minimum compressive strength at 28 days when cured in a moist room at a temperature within the range of 65 degrees to 75 degrees Fahrenheit (18 degrees to 24 degrees Celsius). The desired strength of the concrete shall be shown on either the Plans or in the Specifications.

## CAST-IN-PLACE CONCRETE

- C. Table below shows for each grade of concrete the minimum compressive strength, cement content, and the modulus of rupture. Concrete shall be 5000 psi, Grade 5.0, unless otherwise shown on the Plans.

Concrete Grade	Fine Aggregate	Coarse Aggregate	Min Cement Content *				Minimum Compressive Strength At 28 Days (PSI/MPa)	Minimum Modulus of Rupture At 28 Days (PSI/MPa)	Air Content (% by vol)	Slump at point of placement (inches) **	Water/Cement Ratio (by weight max)
			Type of Cement	Lbs. per C.Y.	Sacks per C.Y.	Kg per m <sup>3</sup>					
5.0	2NS	6AA	II	705	7.5	416	5,000/35.0	5,000 / 5.3	4-6	2-4	0.40
4	2NS	6AA or 17A	I, IA, IS, IS-A	611	6.5	362	4,000/28.0	700 / 4.8	4-6	2-4	0.44
3.5	2NS	6AA or 17A	IS, IS-A or IP, IP-A	564	6	335	3,500/24.0	650 / 4.5	4-6	2-4	0.44
3	2NS	6AA or 17A	IS, IA	517	5.5	305	3,000/20.0	600 / 4.1	4-6	3-5	0.58
CLSM	2NS	NA	I, IA, IS, IS-A	38-282	0.4-3	22-166	50-100/34-0.67	NA	NA	NA	0.40-0.75

\* For concrete with fly ash or GGBFS, values are total of cement plus pozzolan or GGBFS (except CLSM).

\*\* For concrete containing HRWR admixture, slump shall not exceed 8 inches after addition of HRWR to verified 2-4 inches slump concrete.

Where fibrous concrete is required, provide 1.5% -3%=1.5-4.5 pounds per cubic yard. Add per manufacturer's

- D. Aggregates shall be proportioned by weight, except for small structures and for incidental Work requiring less than ten (10) cubic yards (7 m<sup>3</sup>) of concrete, in which case they may be proportioned by volume when approved by ENGINEER.
- E. Cement in bulk, when permitted, shall be proportioned by weight.
- F. When proportioned by volume, the amount of each aggregate required for a single batch shall be measured separately and accurately.
1. Shovel methods of measuring will not be permitted.
  2. Unit of volumetric measurement shall be one (1) cubic foot or one (1) cubic yard.
- G. When proportioned by weight, the amount of each aggregate required for a single batch shall be weighed in a separate container.
1. Equipment for weighing shall be of an approved type, and of such accuracy that there shall not be an error of more than one (1) percent in any one (1) batch.

### 2.9 BATCHING ADMIXTURES

- A. Batching of admixtures to achieve and maintain production of the mix design of concrete shall be in accordance with ACI 212.

## CAST-IN-PLACE CONCRETE

- B. If the air content is found to be less or greater than the specified amount, CONTRACTOR shall immediately discontinue Work and correct the air content.
- C. Decreasing the air content may be accomplished by blending air-entraining Portland cement with Portland cement, manufactured at the same mill, in a ratio which will reduce the air content to a value within the specified limits, this blending shall be reviewed by ENGINEER.
- D. Increasing the air content may be accomplished by adding to each batch a sufficient amount of air-entraining admixture to bring the air content up to the designed amount.
- E. Pozzolan and ground granulated blast furnace slag shall be proportioned based on the mix design approved by ENGINEER per Article 1.09 of this Section to produce watertight concrete.
- F. Water Reducer can be used to reduce the water requirement of concrete to obtain consistency of slump, modify workability, increase strength or any other approved use.

### 2.10 TEMPERATURE LIMITS OF MIXTURE

- A. The temperature of the cement, at the time of delivery to the mixer, shall not exceed 165 degrees F (74 degrees Celsius). It may be required that it be stored at CONTRACTOR's expense until cooled to that temperature.
- B. Temperature limits of aggregates and water entering the mixer shall be as follows:

Mix Components	Minimum	Maximum
Water	75°F (24°C)	140°F (60°C)
Fine Aggregate	65°F (18°C)	140°F (60°C)
Coarse Aggregate	65°F (18°C)	110°F (43°C)
Concrete (resulting)	60°F (15°C)	90°F (32°C)

### 2.11 MIXERS AND MIXING

- A. Concrete mixing operations shall be in accordance with ACI 304, and shall be subject to random inspection during the progress of the Work at no charge to CONTRACTOR.
- B. Central Mixed Concrete:
  - 1. Mixers shall be capable of quickly and completely discharging without segregation or loss.
    - a. Efficiency of the mixers shall be maintained at all times through repair or replacement of worn parts when necessary.

## CAST-IN-PLACE CONCRETE

- b. They shall be provided with readily adjustable, automatic devices which will measure the cement and water within one (1) percent and admixtures within three (3) percent.
    - c. Drum of the mixer shall be kept free from hardened concrete and shall be completely emptied before recharging.
    - d. Retempering or remixing concrete that has partially set will not be permitted.
    - e. Mixer shall be cleaned thoroughly each time when out of operation for more than 1/2 hour.
  2. Recommended mixing time is a minimum time of one (1) minute for one (1) cubic yard (or cubic meter), with an additional 15 seconds for each additional cubic yard (or cubic meter).
  3. Concrete shall be delivered to the site in clean, tight truck bodies designed for this purpose and painted with paraffin, if necessary, for easy dumping.
  4. Concrete at the point of delivery shall have the proper consistency and shall be free from segregation.
    - a. Mechanical agitators in the truck bodies will be required if the period of time from the mixing plant to the point of dumping exceeds 30 minutes.
  5. No concrete shall be dumped if the elapsed time from the mixing plant to the point of dumping exceeds 60 minutes.
- C. Transit Mixed Concrete: Transit-mix concrete shall be in accordance with ASTM C94. If transit-mix concrete is used, it shall meet all the foregoing requirements specified for central mixed concrete and, in addition, the following:
  - a. Batched materials shall be properly proportioned and in a dry state.
  - b. The proper amount of water shall be added to the mixer on the trucks, and no additional water shall be added.
  - c. No admixtures or accelerators shall be added except as herein noted, without the approval of ENGINEER.
  - d. Trucks shall not be loaded beyond their rated capacity and shall have mixing drums cleaned of all set-up materials at frequent intervals while in use.
  - e. Trucks with leaking water valves shall not be used.
  - f. Recommended mixing speed should be no less than 12 revolutions per minute, with a minimum of 90 revolutions or until the mix is satisfactory.
  - g. Mixing shall be continuous after water is added to the mix in the drum, but no concrete shall be placed in the forms more than 90 minutes after water is added to the mix.
- D. Truck-mixed concrete shall be delivered to the site of the Work and discharged from the mixer within the maximum period of 1-1/2 hours from the first introduction of water to the mix.
  - a. Any concrete which remains in the mixer after this period and any concrete which appears too stiff to be properly workable

## **CAST-IN-PLACE CONCRETE**

or which appears to have begun to take its initial set shall be rejected and removed from the site of the Work.

- b. OWNER may employ an independent testing laboratory to provide a qualified inspector to be present at the plant where batching of concrete occurs.
  - (1) The inspector shall verify the compliance of the mix with the Specifications and shall sign a form indicating the quantity of concrete and the concrete mixture of each load.

### **2.11 CHANGE OF MIXTURE**

- A. If CONTRACTOR requests a change or substitution of approved batch proportioning, mixing, or delivery operations additional testing and/or inspection shall be at CONTRACTOR's expense.

### **2.12 ACCEPTABLE MANUFACTURERS**

- A. Acceptable manufacturers of abrasive wear resistant floor finish include: Master Builders Company "Mastercon Aggregate," Sonneborn Building Products "Harcot," or equal.

## **PART 3      EXECUTION**

### **3.1 VERIFICATION OF FORMWORK, REINFORCING, AND SUBGRADES**

- A. CONTRACTOR shall inspect formwork, reinforcement and subgrades to confirm compliance with the related Work specified elsewhere.

### **3.2 EMBEDDED ITEMS**

- A. CONTRACTOR shall verify the location, from certified vendor or applicable engineering drawings, of all embedded items including anchor bolts, wall sleeves, wall casting, railing post sleeves and miscellaneous pipes and conduits and shall install the items accurately at the locations determined.

### **3.3 BUILDING IN OTHER WORK**

- A. CONTRACTOR shall make all necessary provisions in concrete Work for other Work installed by this or other contractors, and build in all required steel beams, frames, curbs, expansion joints, inserts, hangers, pipes, floor drains, pipe trench covers and frames, anchors, sleeves, floor ducts, fiber and steel conduit, pipe hanger sockets, and all other Work furnished by either this or other contractors.
- B. The CONTRACTOR shall build in all anchors, ties, etc., specified under brick and other Work, in faces of concrete Work which are to be faced with masonry, and any other Work shown or noted to be built into concrete. In



## CAST-IN-PLACE CONCRETE

addition, the CONTRACTOR shall provide all openings and holes in concrete Work as shown or as needed to accommodate other Work.

### 3.4 SPECIAL CONCRETE

- A. CONTRACTOR shall verify the use and/or locations of watertight concrete and/or high-early strength concrete.

### 3.5 PREPARATION

- A. CONTRACTOR shall notify ENGINEER two (2) working days prior to placement of concrete.
- B. Before depositing new concrete on or against existing concrete the existing concrete shall be roughened, thoroughly cleaned of foreign matter and laitance and saturated with water. The cleaned and saturated surface of the hardened concrete, including vertical and inclined surfaces, shall be coated with a bonding agent or slushed with a minimum 2-inch (50 mm) thick coating of concrete without coarse aggregate grout against which the new concrete shall be placed before the mixture has attained its initial set.
- C. Before concrete is placed in any unit, the forms and the placing and fixing of all steel and incidental items shall be complete, and the forms, steel and adjacent concrete shall be thoroughly cleaned and wetted down.
- D. Where indicated on the Plans, CONTRACTOR shall bridge the subgrade with at least 2,000 psi (13.8 MPa), 3-inch (75 mm) thick lean concrete before placing the reinforcement. This shall be at no extra cost.
- E. No concrete shall be deposited in any unit until the area has been completely dewatered in accordance with Section 31 2319, Dewatering, and not until after CONTRACTOR has made satisfactory provisions to eliminate all possibility of water entering or flowing through the concrete while it is being poured or is taking its set. No concrete shall be placed under or on water.

### 3.6 CONVEYING

- A. Concrete handling equipment shall be of such a nature and shall be so located that the concrete after leaving the mixer will reach its destination with a minimum lapse of time, with no segregation, and loss of slump.
  - 1. Use of drop chutes, except at or in the forms, is prohibited.
- B. The interior hopper slope of concrete buckets shall be not less than 60 degrees from the horizontal, the minimum dimension of the clear gate opening shall be at least five (5) times the nominal maximum size aggregate and the area of the gate opening shall be not less than two (2) square feet (0.2 m<sup>2</sup>). The maximum dimension shall not be greater than twice the minimum dimension.

## CAST-IN-PLACE CONCRETE

1. Bucket gates shall be essentially grout tight when closed and may be manually, pneumatically or hydraulically operated except for buckets larger than two (2) cubic yards (1.5 m<sup>3</sup>) shall not be manually operated.
  2. Design of the bucket shall provide means for positive regulation of the amount and rate of deposit of concrete in each dumping position.
- C. Belt conveyors shall be designed and operated to assure a uniform flow of concrete from mixer to final place of deposit without segregation of ingredients or loss of mortar and shall be provided with positive means for preventing segregation of the concrete at the transfer points and the point of placing.
- D. Concrete may be conveyed by positive displacement pump when authorized by ENGINEER.
1. The pumping equipment shall be piston or squeeze pressure type.
  2. The pipeline shall be rigid steel pipe or heavy duty flexible rubber hose.
  3. The inside diameter of the pipe shall be at least three (3) times the nominal maximum size coarse aggregate in the concrete mixture to be pumped.
  4. The maximum size coarse aggregate shall not be reduced to accommodate the pumps.
- E. Distance to be pumped shall not exceed limits recommended by the pump manufacturer. The concrete shall be supplied to the pump continuously.
- F. When pumping is completed, concrete remaining in the pipeline shall be ejected without contamination of concrete in place.
- G. After each operation, equipment shall be thoroughly cleaned, and flushing water shall be wasted outside of the forms.

### 3.7 PLACING

- A. Concrete shall be so deposited as to maintain the top surface level, unless otherwise shown on the Plans, and also as to avoid any appreciable flow in the mass.
- B. Where placing operations involve dropping the concrete more than three (3) feet (1 m) in the forms, it shall be deposited through sheet metal or other approved spouts or pipes.
1. These spouts or pipes shall have suitable receiving hoppers at the upper ends, and the lower ends shall be kept within six (6) inches (150 mm) of the newly placed concrete so as to prevent segregation and avoid spattering the reinforcing steel with mortar.

## CAST-IN-PLACE CONCRETE

2. Under no circumstances shall concrete that has partly hardened be deposited in the Work.
- C. Each layer of concrete shall be plastic when covered with the following layer and the forms shall be filled at a rate of vertical rise of not less than two (2) feet (600 mm) per hour.
1. Concrete vibrators shall penetrate the initial layer when placing the following layer.
  2. Vertical construction joints shall be provided as necessary to comply with these requirements.
- D. Concrete shall be placed and compacted in wall or column forms before any reinforcing steel is placed in the system to be supported by such walls or columns.
1. The portion of any wall or column placed monolithically with a floor or roof slab shall not exceed six (6) feet (1.8 m) of vertical height.
  2. Concrete in walls or columns shall set at least two (2) hours before concrete is placed in the structural systems to be supported by such walls or columns.
- E. Concrete shall be set when top finished. Laitance, debris, and surplus water shall be removed from concrete surfaces at tops of forms by screeding, scraping, or other effective means. Wherever the top of a wall will be exposed to weathering, the forms shall be overfilled and after the concrete has settled, the excess shall be screeded off.
- F. No concrete shall be placed in contact with frozen ground.
- G. Time between charging and placement of concrete shall not exceed 1-1/2 hours.
- H. Concrete shall be compacted by continuous vibrating, tamping, spading or slicing. Mechanical vibration shall be employed.
1. Care shall be taken to eliminate all voids and to provide full bond on reinforcing steel and embedded fixtures.
  2. Concrete shall be compacted and thoroughly worked with suitable tools combined with the use of vibrators applied internally and providing a frequency not less than 7,000 revolutions per minute.
  3. All such vibrating, including the methods and equipment, shall be subject to the review of ENGINEER.
- I. The time of vibrating in any area shall only be sufficient to get efficient compaction, but shall in no case be carried to the point where there is segregation of the fine and coarse materials of the mix.
1. There shall be an absolute minimum of direct vibration of the steel or forms during the process of vibrating.
  2. Vibrators shall be inserted and withdrawn from the concrete at numerous locations, from 18 to 30 inches (450 to 750 mm) apart, but shall not be used to transport concrete within the forms.

## CAST-IN-PLACE CONCRETE

3. CONTRACTOR shall have a stand by vibrator on the job site during all concrete pouring operations.

### 3.8 FINISHING UNFORMED SURFACES

- A. Unformed surfaces of all concrete shall be screeded and given an initial float finish followed by steel troweling.
- B. Screeding shall provide a concrete surface conforming to the proper elevation and contour with all aggregates completely embedded in mortar.
  1. Screeded surfaces shall be free of surface irregularities with a height or depth in excess of 1/4 inch (5 mm) as measured from a 10-foot (3 m) straightedge.
- C. Screeded surfaces shall be given an initial float finish as soon as the concrete has stiffened sufficiently for proper working.
  1. Any piece of coarse aggregate which is disturbed by the float or which causes a surface irregularity shall be removed and replaced with mortar.
  2. Initial floating shall produce a surface of uniform texture and appearance with no unnecessary working of the surface.
  3. Floating shall be performed with hand floats or suitable mechanical compactor floats.
- D. Troweling shall be performed after the second floating when the surface has hardened sufficiently to prevent an excess of fines being drawn to the surface. Troweling shall produce a dense, smooth, uniform surface free from blemishes and trowel marks.
  1. Top surface of driveways, and sidewalks shall be given a broomed finish after troweling.
- E. Unless specified to be beveled, exposed edges of floated or troweled surfaces shall be edged with a tool having 1/4 inch (5 mm) corner radius.

### 3.9 FINISHING FORMED SURFACES

- A. After removal of forms, the finishing of all concrete surfaces shall be started as soon as its condition will permit. Grind all seams, fins or projections flush with the concrete surface.
  1. Fill and point all honeycomb, tie holes and voids.
  2. Dampen the surface with water and apply a cement and silica sand slurry to the entire surface to fill small defects and air voids.
  3. Remove excess slurry from concrete. Surfaces to be finished shall receive an application of dry Portland cement which shall be rubbed into the slightly dampened surface with a suitable cloth.

## CAST-IN-PLACE CONCRETE

- B. After pointing and removal of projections as specified herein, exposed surfaces of concrete, including walls, columns, beams, pilasters and the undersides of slabs, shall be given a rubbed surface finish.

### 3.10 FLOORS

- A. Concrete floor finish shall be applied to all building floors not receiving further floor finish. At these locations, the concrete shall be brought to the proper elevation and screeded. Surface shall be given two (2) steel trowelings when the concrete has set sufficiently to finish smoothly.
  - 1. Floors shall be sloped uniformly toward floor drains at a slope of 1/8 inch per foot (10 mm per meter).
- B. Concrete finish on steps and loading platforms shall be wood troweled to true and uniform surface and then steel troweled. The surface shall then be slightly roughened with a broom or by dragging burlap across the surface.
- C. Concrete floors shall be finished with an abrasive resistant floor finish in the area of the newly replaced floor.
  - 1. Premixed floor hardener shall be applied to the surface of the freshly floated concrete floor, in strict accordance with the manufacturer's directions. Color to be selected by OWNER.
  - 2. Once properly cured, the final surface coating shall be applied to the floor.

### 3.11 CONCRETE CURING

- A. Concrete shall be cured for a period not less than seven (7) consecutive days.
- B. CONTRACTOR shall have adequate equipment and curing material on the job site before concrete placement begins, and it shall be adequate to prevent checking and cracking and loss of moisture from all the surfaces of the concrete.
  - 1. Concrete shall be protected from rain, flowing water, wind and the direct rays of the sun.
  - 2. Openings in concrete shall be sealed to prevent drying of the concrete during the curing period.
- C. Curing compounds shall not be used on surfaces to which additional concrete or other material are to be bonded.
- D. Curing compounds when used shall be applied in strict accordance with the manufacturer's recommendations.
- E. Concrete cured with water shall be kept wet by covering with ponded water or fog spraying to keep all surfaces continuously wet.

## CAST-IN-PLACE CONCRETE

- F. Horizontal construction joints and finished surfaces cured with sand shall be covered a minimum thickness of 1-inch (25 mm), uniformly, and kept saturated during the curing period.
- G. Burlap used for curing shall be treated to resist rot and fire and free of sizing or any substances that are injurious to Portland cement or cause discoloration.
  - 1. Strips shall be lapped by half widths.
  - 2. The burlap shall be saturated with water after placement and during the curing period.
- H. Straw or hay shall be in a layer no less than six (6) inches (150 mm) thick and held in place by screens, wire or other means to prevent dispersion by the wind.
  - 1. Care shall be observed to avoid discoloration of the concrete surface from the vegetable fibers and for the flammability of the material.
  - 2. The straw shall be saturated with water after placement and during the curing period.

### 3.12 ENVIRONMENTAL CONDITIONS

- A. CONTRACTOR shall provide cold or hot weather protection in accordance with ACI and as specified herein. There shall be no additional cost for hot or cold weather protection of the concrete.
- B. Cold Weather Protection:
  - 1. When placing concrete in cold weather, CONTRACTOR shall plan and prosecute his Work in a manner which shall assure results free from damage through freezing, contraction, and loss of concrete strength.
  - 2. No concrete shall be poured when the surrounding temperature is below 40 degrees Fahrenheit (4degrees Celsius), unless the aggregates and water are properly heated.
    - a. Concrete which has been poured at higher temperatures but has not attained a strength equal to 75 percent of the required strength of the class of concrete involved, shall be housed and protected in accordance with the provisions of this Section whenever the surrounding temperature falls below 40 degrees Fahrenheit (4degrees Celsius).
  - 3. Application of heat to the materials shall be made in a manner which will keep these materials clean and free from injurious substances.
  - 4. Aggregates may be heated only by steam coils or steam jets, except in the case of small quantities of concrete when other methods may be approved by ENGINEER. A sufficient quantity of properly heated aggregates shall be on hand prior to starting the pouring of any unit.
  - 5. Concrete shall be properly housed with canvas, burlap, or other windproof material in such a manner that any necessary removal of the forms or finishing of the concrete can proceed without undue damage to the concrete from the elements.

## CAST-IN-PLACE CONCRETE

- a. Heating of the housing shall be done in a manner which will maintain a temperature between 50 degrees Fahrenheit and 70 degrees Fahrenheit (10degrees and 20degrees Celsius, respectively), at all times for at least five (5) days after the pour is complete and 12 hours before the pour begins.
  - b. All supplemental heating units shall have exhaust vented to the exterior and shall not cause deleterious reactions or deposits to occur to concrete.
- C. Hot Weather Protection:
1. Concrete deposited in hot weather shall not have a placing temperature that will cause difficulty from loss of slump, flash set, or cold joints. Concrete temperature shall be less than 90 degrees Fahrenheit (32 degrees Celsius).
  2. In hot weather, suitable precautions shall be taken to avoid drying of the concrete prior to finishing operations. Use of windbreaks, sunshades, fog sprays, or other devices shall be provided.

### 3.13 ADDITION OF WATER

- A. To increase workability, adding water to the mix shall be limited to a one time addition of one (1) gallon of water per cubic yard of concrete (5 liters per cubic meter) and mixed with a minimum of 30 revolutions at a rate of 12 to 15 revolutions per minute. Addition of water shall be within the slump requirements.

### 3.14 CONCRETE DELIVERY TICKET

- A. A ticket system shall be used for recording the transportation of concrete from the batching plant to point of delivery. This ticket shall be issued to the truck operator at the point of loading and given to ENGINEER upon delivery. The ticket shall as a minimum indicate the time of mixer charging, quantity of concrete, type of mixture including amount of cement, and the plant where the concrete was batched.

### 3.15 CONCRETE DELIVERY REJECTION

- A. Concrete not permitted for inclusion in the Work by ENGINEER shall be removed from the site. Rejection of concrete will be determined through concrete testing and elapsed time from mixer charging to delivery.

### 3.16 CONCRETE TESTING AT PLACEMENT

- A. Tests shall be made of fresh concrete for each 50 cubic yards (40 m<sup>3</sup>), or whenever consistency appears to vary. The sampling and testing of slump, air content and strength will be performed at no cost to CONTRACTOR.

## CAST-IN-PLACE CONCRETE

- B. Composite samples shall be secured in accordance with the Method of Sampling Fresh Concrete, ASTM C172.
- C. Slump Test:
  - 1. Slump Test shall be in accordance with ASTM C143. CONTRACTOR shall use the least slump possible consistent with workability for proper placing of the various classifications of concrete.
  - 2. A tolerance of up to 1-inch (25 mm) above the indicated maximum slump shall be allowed for individual batches provided the average for all batches or the most recent ten (10) batches tested, whichever is fewer, does not exceed the maximum limit.
- D. Air Content:
  - 1. Air content of normal weight concrete will be determined in accordance with Method of Test for Air Content of Freshly Mixed Concrete by the Pressure Method, ASTM C231.
- E. Compressive Strength:
  - 1. A set of cylinders for compressive strength tests will consist of four cylinders per each set.
  - 2. Molding and curing specimens from each set shall be in accordance with Method of Making and Curing Concrete Test Specimens in the Field, ASTM C31. Deviations from the requirements of this Standard shall be recorded in the test report.
  - 3. Testing specimens will be in accordance with Method of Test for Compressive Strength of Cylindrical Concrete Specimens, ASTM C39.
    - a. One (1) specimen shall be tested at seven (7) days for information and two (2) shall be tested at 28 days for acceptance. The acceptance test results shall be the average of the strengths of the two (2) specimens tested at 28 days.
    - b. If one (1) specimen in a test manifests evidence of improper sampling, molding or testing, it shall be discarded and the strength of the remaining cylinder shall be considered the test result.
  - 4. The strength level of the concrete will be considered satisfactory so long as the averages of all 28 day strength test results equal or exceed the specified 28-day strength and no individual strength test result falls below the specified 28-day strength by more than 500 psi (3.4 MPa).
  - 5. If the strength test is not acceptable, further testing shall be performed to qualify the concrete.
- F. The temperature of concrete sample will be determined for each strength test.



## CAST-IN-PLACE CONCRETE

### 3.17 TESTING OF CONCRETE IN PLACE

- A. Additional testing of materials or concrete occasioned by their failure by test or inspection to meet specification requirements shall be at the expense of CONTRACTOR.
- B. Testing by impact hammer, sonoscope, or other nondestructive device may be permitted by ENGINEER to determine relative strengths at various locations in the structure as an aid in evaluating concrete strength in place or for selecting areas to be cored. Such tests, unless properly calibrated and correlated with other test data, shall not be used as a basis for acceptance or rejection.
- C. When required by ENGINEER, cores at least two (2) inches (50 mm) in diameter shall be obtained and tested in accordance with Methods of Obtaining and Testing Drilled Cores and Sawed Beams of Concrete, ASTM C42.
  - 1. If the concrete in the structure will be dry under service conditions, the cores shall be air dried (temperature 60 degrees to 80 degrees Fahrenheit (15 degrees to 25 degrees Celsius), relative humidity less than 60 percent) for seven (7) days before test and shall be tested dry.
  - 2. If the concrete in the structure will be more than superficially wet under service conditions, the cores shall be tested after moisture conditioning in accordance with ASTM C42.
- D. At least three (3) representative cores shall be taken from each member or area of concrete in place that is considered potentially deficient.
  - 1. The location of cores shall be determined by ENGINEER so as to least impair the strength of the structure.
  - 2. If, before testing, one or more of the cores shows evidence of having been damaged subsequent to or during removal from the structure, it shall be replaced.
- E. Concrete in the area represented by a core test will be considered adequate if the average strength of the cores is equal to at least 85 percent of and if no single core is less than 75 percent of the specified 28-day strength.
- F. Core holes shall be filled by low slump concrete or mortar.

### 3.18 DEFECTIVE CONCRETE

- A. If, in the opinion of ENGINEER, the defects in the concrete are of such a nature as to warrant condemnation, that portion of the pour may be ordered replaced in its entirety and CONTRACTOR shall promptly replace same without additional compensation.

## **CAST-IN-PLACE CONCRETE**

- B. Defective concrete shall be repaired by cutting out the defective area and placing new concrete which shall be formed with keys, dovetails or anchors to attach it securely in place.

END OF SECTION

**SECTION 03 70 00**  
**CONCRETE REPAIR AND REHABILITATION**

**PART 1**      **GENERAL**

1.1      SCOPE OF WORK

- A.      CONTRACTOR shall furnish materials, labor, tools, and equipment necessary to repair, patch, and restore poorly placed, deteriorated or rejected concrete. This includes removal, surface preparation and installation of repair materials at deteriorated areas, cracks, and openings in concrete floors and walls, as indicated on the drawings, as directed in the field and as specified herein.

1.2      RELATED WORK SPECIFIED ELSEWHERE

- A.      Section 03 3000: Cast-In-Place Concrete
- B.      Section 09 9000: Painting

1.3      REFERENCE STANDARDS

- A.      ASTM C 109, Test Method for Compressive Strength of Hydraulic Cement Mortars.
- B.      ASTM C 157, Test Method for Length Change of Hardened Cement Mortar and Concrete.
- C.      ASTM C 882, Test Method for Bond Strength of Epoxy-Resin Systems Used with Concrete.
- D.      ASTM D 412, Test Methods for Vulcanized and Thermoplastic Rubbers and Thermoplastic Elastomers-Tension.
- E.      ASTM D 624, Test Methods for Tear Strength of Conventional Vulcanized Rubber and Thermoplastic Elastomers.
- F.      ASTM D 903, Test Methods for Peel or Stripping Strength of Adhesive Bonds.
- G.      ASTM D 3359: Standard Test Methods for Measuring Adhesion by Tape Test.
- H.      SSPC-SP13/NACE No. 6 Surface Preparation of Concrete.
- I.      ACI 440.2R-02: Guide for the Design and Construction of Externally Bonded FRP Systems for strengthening concrete.

1.4      SUBMITTALS

- A.      Submit manufacturer's data completely describing structural repair concrete materials:
  - 1.      Product Data.
  - 2.      Certificate of Compliance.
  - 3.      Manufacturer's Instructions.

## **CONCRETE REPAIR AND REHABILITATION**

### 1.5 QUALITY ASSURANCE

- A. Manufacturer Qualifications: The manufacturer of the specified product shall have been in existence, for a minimum of 10 years.
- B. Construction Tolerances: Construction tolerances shall be as specified in Section 03300, Cast-In-Place Concrete, except as modified herein and elsewhere in the Contract Documents.

### 1.6 DELIVERY, STORAGE, AND HANDLING

- A. Deliver the specified product in original, unopened containers with the manufacturer's name, labels, product identification, and batch numbers.
- B. Store and condition the specified product as recommended by the Manufacturer.
- C. Store in a suitable location approved by ENGINEER at all times. Keep area clean and accessible. Comply with health and fire regulations including the Occupational Safety and Health Act of 1970.
- D. Handle materials carefully to prevent inclusion of foreign materials.
- E. Do not open containers or mix components until necessary preparatory work has been completed and application work will start immediately.

### 1.7 PROJECT/SITE CONDITIONS

- A. Existing Conditions:
  - 1. Hot Weather: ACI 305.
  - 2. Cold Weather: ACI 306.
  - 3. Do not place concrete repair mortar during precipitation, unless adequate protection is provided.
  - 4. Coordinate coatings application with other trades to assure adequate illumination, ventilation, and dust-free environment during application and curing of coatings.
  - 5. Maintain a safe work environment in accordance with Federal, State, Local and project site regulations and guidelines.

## **PART 2      PRODUCTS**

### 2.1 MANUFACTURERS

- A. Sika Corporation,
- B. ENGINEER-approved equal.

## CONCRETE REPAIR AND REHABILITATION

### 2.2 MATERIALS

- A. Repair Mortar: Sikatop 122 Plus, SikaTop 123 Plus, or SikaTop 126 Plus by the Sika Corporation or equal, approved by ENGINEER.
- B. Joints between existing and new Precast Wall Panels: Sikadur Combiflex as manufactured by Sika Corporation or equal, approved by ENGINEER.
- C. Exposed Rebar Repair: Sikatop Seal 107 as manufactured by Sika Corporation or equal, approved by ENGINEER.
- D. Cementitious Coating: Sikatop 144 by Sika Chemical Corporation or equal, approved by ENGINEER.

### 2.3 MIXES

- A. Repair Mortar:
  - 1. Repair mortar shall be a prepackaged cement based product specifically formulated for the repair of concrete surface defects. The repair mortar shall be a two-component polymer-modified, Portland cement, fast setting, trowel-grade mortar. Repair mortar shall be enhanced with a penetrating corrosion inhibitor. It shall have the following properties:

Physical Property	Value	ASTM Standard
Compressive Strength (minimum)		C 109
at 1 day	2000 psi	
at 28 days	6000 psi	
Bond Strength (minimum)		C 882*
at 28 days	1800 psi	
* Modified for use with repair mortars.		

- 2. Where the least dimension of the placement in width or thickness, exceeds 4 inches, the repair mortar shall be extended by addition of aggregate as recommended by the manufacturer.
- B. Exposed Rebar Repair: Exposed reinforcing repair system shall consist of two components, a first application of a corrosion inhibitor and then a final application of a protective slurry mortar.
  - 1. Corrosion Inhibitor: The corrosion inhibitor shall penetrate the hardened concrete surface and form a protective layer on the reinforcement. It shall have the following properties:
    - a. The product shall not change the substrate's color, appearance, or texture.
    - b. Penetration (SNMS Analysis): 1/10 to 4/5 inches/day.
    - c. Coating thickness (XPS and SIMS Analysis): 100-1000 angstroms.
    - d. Corrosion Current Reduction (ASTM G109 Cracked Beam Test): 65% at 1 year.
    - e. Chloride Displacement (XPS and SIMS Analysis): Passes.
    - f. Effectiveness in Carbonated Conditions (Electrochemical): Passes.

## CONCRETE REPAIR AND REHABILITATION

- g. The product must not form a vapor barrier.
  - h. The product must be environmentally sound.
  - i. Post-application verification (Chromatography Plate Test): Passes.
  - j. Longevity (10 Year Accelerated Weather Testing): Passes.
2. Protective Slurry Mortar:
- a. Protective slurry mortar shall be a two-component, polymer-modified, cementitious waterproofing, and protective slurry mortar. Provide two coats at a rate of 50 sq. ft./gal./coat.

### **PART 3**      **EXECUTION**

#### 3.1 EXAMINATION

- A. CONTRACTOR shall examine areas and conditions under which repair Work is to be installed, and notify ENGINEER in writing of conditions detrimental to proper and timely completion of Work. Do not proceed with Work until unsatisfactory conditions have been corrected in a manner acceptable to ENGINEER.

#### 3.2 PREPARATION

- A. Surface Preparation:
  - 1. The entire area to be repaired shall have all laitance, foreign material, and unsound concrete removed by chipping and/or abrasive blasting or hydroblasting. The surface shall be further roughened as specified herein. Where non-shrink grout or repair mortar is used, any additional surface preparation steps recommended by the manufacturer shall be performed.
  - 2. Where repair concrete, shotcrete, or cement grout is used, and a bonding agent is not required, or where the repair mortar or non-shrink grout manufacturer recommends a wet or saturated surface, water shall be delivered to the surface continuously for a minimum of 4 hours. Where large surface areas are to be repaired, fog spray nozzles mounted on stands shall be provided in sufficient numbers such that the entire surface to be repaired is in contact with the fog spray cloud. The concrete shall be prevented from drying until after the repair operation is completed. Unrepaired surfaces shall be rewetted by water spray on at least a daily basis. Should more than 4 days to be elapsed without rewetting the unrepaired surfaces, the original saturating procedure shall be repeated. All standing water in areas to be repaired shall be removed prior to placement of repair material. Means to remove excess water from the structure shall be provided.
  - 3. Where the repair material manufacturer recommends the use of an epoxy bonding agent, the recommendations of both the repair material and bonding agent manufacturers shall be followed.
  - 4. Care shall be taken to fully consolidate the repair material, completely filling all portions of the area to be filled.
  - 5. The repair surface shall be brought into alignment with the adjacent existing surfaces to provide a uniform, even surface. The repair surface shall match adjacent existing surfaces in texture and shall receive any

## CONCRETE REPAIR AND REHABILITATION

coatings or surface treatments which had been provided for the existing surface.

6. Curing:
  - a. Curing of repair mortar and non-shrink grout shall be according to the manufacturer's recommendations except that the minimum cure period shall be 3 days.
  - b. Curing of other materials shall be according to Section 03 3000, Cast-in-Place Concrete.

### B. Treatment of Surface Defects:

1. Surface defects are depressions in a concrete surface which do not extend all the way through the member. Depressions can result from the removal of an embedded item, the removal of an intersecting concrete member, physical damage, unrepaired rock pockets created during original placement, or spalls from corroded reinforcing steel or other embeds.
2. Preparation:
  - a. Loose, damaged concrete shall be removed by chipping to sound material.
  - b. Where existing reinforcing bars are exposed, concrete shall be removed to a minimum of one inch all around the bars. If the existing bars are cut through, cracked, or the cross sectional area is reduced by more than 25 percent, the Engineer shall be notified immediately.
  - c. The perimeter of the damaged area shall be score cut to a minimum depth of 0.5 inch and a maximum depth so as to not cut any existing reinforcing steel. Existing concrete shall be chipped up to the score line so that the minimum thickness of repair mortar is 0.5 inch.
3. Repair Material:
  - a. Repair of surface defects in members which are normally in contact with water or soil or in the interior surfaces of enclosed chambers which contain water shall be made only with repair mortar.
  - b. Repair of other surface defects may be by the application of repair mortar, repair concrete, shotcrete, or cement grout, as appropriate.

### C. Patching of Holes in Concrete:

1. For holes larger than 48 inches, see the Contract Drawings for reinforcement details.

### D. Patching of Lined Holes:

1. This section applies to those openings which have embedded material over all or a portion of the inside edge. Unless indicated to remain in place on the Contract Drawings or by ENGINEER, such embedded materials shall be removed and the remaining hole repaired as specified above. The requirements for repairing holes in concrete specified above shall apply as modified herein.
2. Where embedded material is allowed to remain, it shall be trimmed back a minimum of 2 inches from the concrete surface. Embedded material shall be roughened or abraded to promote good bonding to the repair material.

## CONCRETE REPAIR AND REHABILITATION

Any substance that interferes with good bonding shall be completely removed.

3. Any embedded item that is not securely and permanently anchored into the concrete shall be completely removed.
4. Embedded items which are larger than 12 inches in their least dimension shall be completely removed unless they are composed of a metal to which reinforcing steel can be welded. Where reinforcement is required, it shall be welded to the embedded metal.
5. The following additional requirements apply to concrete members which are in contact with water or soil.
  - a. Lined openings which are less than 4 inches in their least dimension shall be filled with epoxy grout.
  - b. Lined openings which are greater than 4 inches but less than 12 inches in their least dimension shall be coated with an epoxy bonding agent prior to being filled with Class I non-shrink grout.
  - c. Lined openings which are greater than 12 inches in their least dimension shall be coated with an epoxy bonding agent and shall have a hydrophilic rubber waterstop or bead of hydrophilic sealant installed to the interior of the opening at the wall centerline, as required by Section 03251, prior to being filled with any approved repair material.

### E. Repair of Deteriorated Concrete:

1. This section pertains to concrete which has been damaged due to corrosion of reinforcing steel, physical damage due to abrasion, and damage due to chemical attack. The only material acceptable for surface repair is repair mortar as specified herein. Where the repaired surface is to be subsequently covered with a PVC liner material, the finishing details shall be coordinated with the needs for installing the liner material.
2. Surface Preparation:
  - a. Loose, broken, softened, and acid contaminated concrete shall be removed by abrasive blasting and chipping down to sound, uncontaminated concrete.
  - b. When the removal of deteriorated concrete is completed, CONTRACTOR shall notify ENGINEER. Two weeks shall be scheduled for ENGINEER to inspect the surface, perform testing for acid contamination, determine if additional concrete must be removed, and to develop any special repair details that may be needed. Should it be determined that additional concrete must be removed to reach sound, uncontaminated material, another two week period shall be scheduled for further evaluation after the end of the additional removal.
  - c. Additional surface preparation shall follow the recommendations of the repair mortar manufacturer.
  - d. Isolated areas of exposed reinforcing bars shall be treated as required for repair of surface defects. If extensive areas of reinforcement are uncovered after removal of deteriorated concrete, repair methods shall be as determined by ENGINEER.



## CONCRETE REPAIR AND REHABILITATION

3. Repair Mortar Placement:
  - a. The procedures recommended by the manufacturer for the mixing and placement of the repair mortar shall be followed.
  - b. After the initial mixing of the repair mortar, additional water shall not be added to change the consistency should the mix begin to stiffen.
  - c. Repair mortar shall be placed to a minimum thickness as recommended by the manufacturer, but not less than 0.50 inch. Where removal of deteriorated concrete results in a repair thickness of less than 0.5 inch to return to original concrete surface location in isolated areas totaling less than 10 percent of the total repair area, additional concrete shall be removed to obtain the 0.5-inch thickness. Where the area with repair thickness of less than 0.5 inch exceeds 10 percent of the total repair area, notify the Engineer. In any case, repair mortar shall be added so that the minimum cover over existing reinforcing steel is 2 inches. CONTRACTOR shall not place repair mortar so as to create locally raised areas. Where there is a transition with wall surfaces which are not in need of repair, the repair mortar shall not be feathered at the transition. A score line shall be sawcut to not less than the minimum repair mortar depth and concrete chipped out to it to form the transition. Care shall be taken to not cut or otherwise damage any reinforcing steel.
  - d. The repair mortar shall be placed to an even, uniform plane to restore the member to its original surface. Tolerance for being out of plane shall be such that the gap between a 12-inch straight edge and the repair mortar surface does not exceed 0.125 inch and the gap between a 48-inch straight edge and the repair mortar surface does not exceed 0.25 inch. This shall apply to straight edges placed in any orientation at any location.
4. Finishing:
  - a. The repair mortar shall receive a smooth, steel trowel finish.
  - b. When completed, there shall be no sharp edges. Exterior corners, such as at penetrations, shall be made with a one-inch radius. Interior corners shall be square.
5. Curing:
  - a. Curing shall be performed as recommended by the repair mortar manufacturer except that the cure period shall be at least 24 hours and shall be by means of a continuous fog spray. If the manufacturer recommends the use of a curing compound, no material shall be used that would interfere with the bond of the protective coating system or adhesive used for placing PVC lining, where required.

### F. Exposed Rebar:

1. The entire area to be repaired shall have all corrosion, foreign materials, and unsound concrete by means of abrasive blasting or hydroblasting.
2. Surface shall be visually dry before application of the corrosion inhibitor. The corrosion inhibitor shall be placed liberally to achieve 100 sq ft/gal coverage in two or more coats by allowing it to soak into the substrate. The

## CONCRETE REPAIR AND REHABILITATION

waiting time between coats is a minimum of one hour. Apply by use of rollers, brushes, or hand-pressure spray equipment.

3. After the last coat of the corrosion inhibitor is applied, a minimum curing time of 24 hours is required.
4. High Pressure Wash all surfaces to remove filmy residue which is left on the surface by the corrosion inhibitor. Residue acts like bond breaker and must be removed before mortar coating.
5. For mortar coating, refer to sections 3.6.C, Repair Mortar Placement, 3.6.D, Finishing, and 3.6.E, Curing.

### G. Cementitious Coating:

1. Surfaces to be repaired shall have all laitance, foreign material, and unsound concrete removed by chipping and/or abrasive blasting or hydroblasting.
2. Follow all other surface preparation and application specifications as recommended by manufacturer.

## 3.3 FIELD QUALITY CONTROL

A. OWNER will employ a testing laboratory to perform field quality control testing. ENGINEER will direct the number of tests and specimens required. CONTRACTOR shall make standard compression test specimens as specified below, under the direct inspection by ENGINEER. CONTRACTOR shall furnish necessary assistance required by ENGINEER. CONTRACTOR shall also furnish labor, material and equipment required including rods, molds, thermometer, curing in a heated storage box, and other incidentals required. Above will be subject to approval by ENGINEER. CONTRACTOR shall furnish necessary storage, curing, and transportation required by the testing.

### B. Field tests of cement based grouts and repair mortar:

1. Compression test specimens will be taken during construction from the first placement of each type of mortar or grout, and at intervals thereafter as selected by ENGINEER to ensure continued compliance with these specifications. The specimens will be made by ENGINEER.
2. Compression tests and fabrication of specimens for repair mortar and non-shrink grout will be performed as specified in ASTM C 109. A set of three specimens will be made for each test. Tests shall be made at 7 days, 28 days, and additional time periods as appropriate.
3. All material, already placed, which fails to meet the requirements of these specifications, is subject to removal and replacement at no cost of OWNER.
4. Cost of all laboratory tests on mortar and grout will be borne by OWNER, but CONTRACTOR shall assist the Engineer in obtaining specimens for testing. However, CONTRACTOR shall be charged for the cost of any additional tests and investigation on work performed which does not meet the specifications. CONTRACTOR shall supply all materials necessary for fabricating the test specimens.
5. Repair Concrete: Repair concrete shall be tested as required in Section 03300, Cast-in-Place Concrete.

**CONCRETE REPAIR AND REHABILITATION**

END OF SECTION

**CONCRETE REPAIR AND REHABILITATION**

**THIS PAGE INTENTIONALLY LEFT BLANK**

**DIVISION 04**

**MASONRY**

**THIS PAGE LEFT BLANK INTENTIONALLY**

**SECTION 04 05 11  
MORTARING AND GROUTING**

**PART 1 GENERAL**

1.1 SUMMARY

- A. This Section includes the preparation and installation of mortar and grout used for bond or primer coats, laying and grouting masonry units, filling the inside annular space of pipe joints, filling cored holes for soldier piles, general patching, grout for riprap and flagstone slope protection, joints in precast structural members, spaces under leveling plates and equipment bases, supporting structures, grouting dowels and anchor bolts.
- B. References:
  - 1. The latest or current ACI Standards, and the "Specifications for Masonry Structures," ACI-530.1, shall govern all mortar and grout work except where otherwise specified herein.
  - 2. ACI: American Concrete Institute
  - 3. ANSI: American National Standards Institute
  - 4. ASTM: American Society for Testing and Materials
  - 5. KTC: Kentucky Transportation Cabinet

1.2 DEFINITIONS

- A. Mortar is a plastic mixture of cementitious materials, admixtures where specified, fine aggregate and water. Grout is a mixture of sand, water, and fine aggregate mixed to a fluid consistency.

1.3 SUBMITTALS

- A. Manufacturer's literature shall be submitted for premixed materials.
- B. Manufacturer's available colors shall be submitted. CONTRACTOR to collect a sample of the existing mortar in an attempt to reasonably match the existing color.

1.4 WARRANTY (NOT USED)

1.5 PRODUCT DELIVERY, STORAGE, AND HANDLING

- A. Materials shall be stored and handled as recommended in ACI 304.
- B. When cement is stored in the open, a floor at least six (6) inches (150 mm) above the ground and a waterproof covering shall be provided and so placed as to insure runoff in case of rain. At the time of its use the cement shall be free from lumps. Cement sacks shall be thoroughly shaken when emptying sacks into the batch. Cement salvaged by the CONTRACTOR by cleaning sacks mechanically or otherwise, or from discarded sacks of cement shall not be used.
- C. The aggregates are to be furnished, stocked and handled so that uniformity of grading will be obtained at the time of batching. The area on which stockpiles

## **MORTARING AND GROUTING**

are to be built shall be thoroughly cleaned of all foreign materials and shall be firm, reasonably level, and well drained. No aggregates which have become intermixed prior to proportioning shall be used.

- D. The premixed mortar or grout shall be stored and handled in strict accordance with the manufacturer's recommendations.

### **1.6 JOB CONDITIONS**

- A. Environmental requirements relative to temperature for mixing and placing mortar or grout shall be in accordance with Articles 2.8 and 3.8 of this Section.

## **PART 2 PRODUCTS**

### **2.1 PREMIXED MORTAR OR GROUT**

- A. Premixed mortar or grout shall be a complete packaged mixture to which water is to be added at the job site. Mortar and grout shall be non-shrink, non-staining.
- B. Grout to be placed under base plates, equipment bases, structural elements and structural anchorages shall be non-shrink grout with a compressive strength of 10,000 pounds per square inch, unless otherwise indicated.

### **2.2 CEMENT**

- A. The type of cement to be used shall be as indicated on the Plans or as specified below:
  1. Portland cement: Types I, IA or III: ASTM C150.
  2. Masonry cement: Type N, S, or M: ASTM C91.
  3. Mortar: Type M or S: ASTM C270.
  4. Hydrated lime: Type S: ASTM C207.

### **2.3 AGGREGATE**

- A. Fine aggregate: Shall be natural sand conforming to KTC Specifications and shall conform to ASTM C33.

### **2.4 ADMIXTURES**

- A. Integral waterproofing compounds, accelerators, retarders or other admixtures not definitely mentioned in the Specifications shall not be used in mortar or grout without the approval of the ENGINEER. Use no admixtures containing calcium chloride.

### **2.5 WATER**

- A. Water shall be free from oil, acid, alkali, organic matter, and any other deleterious substances. Water shall be in accordance with KTC.

### **2.6 MIXES**



## MORTARING AND GROUTING

- A. Water shall be added to premixed mortar or grout in strict accordance with manufacturer's recommendations to prepare a stiff or plastic mix, depending on workability needed for application.
- B. For job mixed mortar or grout, a mixture of cement, aggregate, water and admixtures, if required, shall be combined in proportions meeting the requirements specified below to produce mortar or grout for the use indicated on the Plans and as specified herein.
- C. For job mixed mortar and grout the cement and aggregate shall be proportioned by weight for cubic yard batches or by volume for small batches. Shovel method of volume measuring will not be permitted. When materials are measured by volume, water shall be added in amounts necessary for the consistency required for the Work.
- D. Non-shrinking Mortar and Grout:
  - 1. Unless otherwise indicated on the Plans or Specifications, the cement shall be Portland Type I. The materials shall be proportioned by weight, with water added in amounts to obtain necessary consistency required for the Work.

### 2.7 MIXING

- A. The minimum mixing time shall be five (5) minutes. The consistency of mortar shall be adjusted to provide the best workability. If the mortar begins to stiffen from evaporation or absorption of a part of the mixing water, the mortar shall be re-tempered by adding water and remixing. The consistency of the grout shall be such that at the time of placement, it will completely fill all spaces intended to receive grout.

### 2.8 MIX TEMPERATURE

- A. The temperature of the mix shall be between 40 degrees F and 120 degrees F (4° to 49° C).

### 2.9 ACCEPTABLE MANUFACTURERS

- A. Acceptable manufacturers of premixed, non-shrink, nonmetallic grout include: Sonneborn "Sonogrout"; L and M Construction Chemicals "Duragrout"; Master Builders "Masterflow 713"; Five Star Products "Five Star Grout", or equal.

## MORTARING AND GROUTING

<b>PROPORTIONING STANDARD MORTARS AND GROUTS</b>															
Mortar or Grout Type	General Usage	Materials				Mix Proportions by Dry Weight, (lbs/cyd)					Mix Proportions by Bulk Volume, Parts				
		Portland Cement	Masonry Cement	Hydrated Lime	Fine Agg	Portland Cement	Masonry Cement	Hydrated Lime	Fine Agg	Net Water Approx	Portland Cement	Masonry Cement	Hydrated Lime	Fine Agg	
R-1 Grout	Bond or Primer Coat	Type I, IA	-	-	Type D	1175	-	-	964	705	1	-	-	1	
R-2 Mortar		-	Type M	-	Type D	-	930	-	213 7	415	-	1	-	2-1/2	
		Type I	Type N	-	Type D	468	349	-	199 1	415	(a)	(a)		(a)	
		Type I, IA		Type S, SA	Type D	828	-	75	201 6	415	(a)	-	(a)		(a)
		Type I, IA	-	-	Type D	930	-	-	196 6	415	1	-	-		2-1/2
a. Do not proportion by volume when blending cementitious materials (Portland cement, masonry cement, or lime).															

## MORTARING AND GROUTING

### **PART 3 EXECUTION**

#### 3.1 CONTRACTOR'S VERIFICATION

- A. The CONTRACTOR shall verify the elevation of structural member or equipment bases to be grouted, and/or location of anchoring devices as indicated on the Plans or approved Shop Drawings.
- B. The CONTRACTOR

#### 3.2 PREPARATION

- A. Surfaces to receive mortar or grout shall be prepared as follows, unless otherwise specified:
  - 1. Remove laitance down to sound concrete.
  - 2. Surface shall be properly wet cured, being free of chemical curing compound, oil, grease, dirt and loose particles.
  - 3. Clean bolt and/or tie holes, anchor bolts and underside of bearing plates.
  - 4. Saturate concrete including holes prior to grouting.
- B. When a premixed mortar or grout is used, preparation of surfaces shall be in strict accordance with manufacturer's recommendations.

#### 3.3 INSTALLATION - GENERAL

- A. All mortar and grout shall be used within 2-1/2 hours of initial mixing. No mortar or grout shall be used after it has begun to set.
- B. Premixed mortar or grout shall be used in strict accordance with the manufacturer's recommendations.

#### 3.4 INSTALLATION OF MASONRY UNITS

- A. Mortar joints to bond brick or block shall be no less than 3/8 inch (9 mm) and no greater than 1/2 inch (10 mm) thick. The surface of the joint shall be struck to match the existing joint lines.

#### 3.5 REPOINTING

- A. Remove damaged existing joints and masonry units.
  - 1. Remove the damaged or fractured existing mortar joints to a minimum depth of 1", or as much as may be necessary to reach sound material. Take care to avoid damaging existing masonry units or enlarging width of joints. Mechanical tools such as saws or impact hammers will be permitted only on specific written approval of ENGINEER and demonstrated ability by operators to use without damage to masonry.
  - 2. Repair or replace existing masonry units damaged by cutting, spalling and chipping caused by routing operations.

## MORTARING AND GROUTING

3. Thoroughly remove loose material from joints using a hose stream under normal pressure or by low-pressure compressed air.
4. Repair existing masonry units that are cracked or fractured.
5. Final preparation of the joint shall be done by hand.

### B. Filling the joints.

1. After carefully routing and cleaning joints, wet joints thoroughly and then apply fresh repointing mortar. Allow water to soak into joints, but joints shall not be visibly wet with standing water during tuck pointing.
2. Fill mortar joints in layers not over 1/4" thick with each layer applied with pressure as soon as previous layer has partially dried. Do not tool each layer smooth; leave surface rough to help bond of subsequent layers. Compress the final packing as much as possible to completely fill joint. Compact joints solidly before final tooling.
3. Tool joints concave to match existing. Take care to not spread mortar over edges of brick onto exposed surfaces. Do not featheredge mortar. Cure mortar by maintaining in a damp condition for 5 days.
4. Allow mortar to fully harden for 10 days after completion of work.
5. Thoroughly clean exposed masonry surfaces of excess mortar and foreign matter using stiff nylon or bristle brushes and cleaning agent.

## 3.6 CLEANING-GENERAL

A. Promptly as work proceeds and upon completion, remove excess mortar, smears, efflorescence and droppings.

1. Before cleaning verify that all mortar joints in area to be cleaned have been repointed and are sufficiently hard for cleaning.
2. Test areas to be cleaned to determine the most effective cleaning method starting with the gentlest means possible utilizing brush and water wash at low to medium pressure. If alkaline or acidic cleaning methods are necessary, mask off areas below to protect finishes that may be damaged by chemical cleaners.
3. Start cleaning at the lowest designated wall area and proceed to the top of the wall always keeping surfaces wet below the area being cleaned and rinse frequently to reduce the potential for streaking.
4. After the designated area has been cleaned, wash down the wall areas below.
5. The use of abrasive cleaning will not be permitted.

B. Clean adjacent and adjoining surface of marks arising out of execution of masonry and tuckpointing work.

## 3.7 SURFACE FINISHING APPLICATIONS

## MORTARING AND GROUTING

- A. Non-shrink mortar shall be thoroughly compacted into all voids, holes, honeycombs, or other defects in the finish surface of concrete. The mortar shall be flush with the surrounding concrete and matching in color and texture.

### 3.8 GROUTING ANCHORING DEVICES

- A. Non-shrink, non-staining mortar or grout shall be placed in the hole provided, then the anchoring device or dowel shall be set into the grout filled hole. The surface shall be flush with the surrounding concrete. No pressures or loads shall be applied to the anchoring device until the mortar or grout has attained its ultimate strength.

### 3.9 GROUTING PLATES AND STRUCTURAL MEMBERS

- A. Thoroughly fill the area between the foundation and plate or member with nonshrink, nonmetallic grout. If required, immediately set shims and align plate or member as required. After the grout has set hard remove forms or shims and finish with a capping mortar.

### 3.10 COLD WEATHER WORK

- A. No masonry units, mortar or grout Work shall be placed in contact with frozen surfaces. No mortar or grout Work shall be performed when the mean air temperature is below 40 degrees F (4° C) unless the materials are heated and/or the CONTRACTOR provides adequate protection of the Work. All Work shall be protected against freezing for no less than 48 hours after placement.
- B. Application of heat to the materials shall be made in a manner which will keep these materials clean and free from injurious substances.
  - 1. Air Temperature 40 degrees F to 32 degrees F (4° to 0° C):
    - a. Sand or mixing water shall be heated to produce mortar temperatures between 40 degrees F and 120 degrees F (4° to 49° C). Heating of either of the ingredients shall be to a minimum 70 degrees F and maximum 160 degrees F (21° to 71° C). The ideal mortar temperature should be 70 degrees F to 80 degrees F (21° to 27° C).
  - 2. Air Temperature 32 degrees F to 25 degrees F (0° to 4° C):
    - a. Sand and mixing water shall be heated to produce mortar temperatures between 40 degrees F and 120 degrees F (4° to 49° C). Maintain temperatures of mortar on boards above freezing. Heat sand and water to a minimum 70 degrees F and maximum 160 degrees F (21° to 71° C).
  - 3. Air Temperature 25 degrees F to 20 degrees F (-4° to -9° C):
    - a. Sand and mixing water shall be heated to produce mortar temperatures between 40 degrees F and 120 degrees F (4° to 49° C). Maintain mortar temperatures on boards above freezing. Salamanders or other sources of heat shall be used on both sides of interior bearing walls under construction and on the inside of all exterior walls. Windbreaks shall be employed when wind is in excess of 15 mph (24 kph).

## MORTARING AND GROUTING

4. Air Temperature 20 degrees F (-7° C) and Below:
  - a. Sand and mixing water shall be heated to provide mortar temperatures between 40 degrees F and 120 degrees F (4° to 49° C). Enclosure and auxiliary heat shall be provided to maintain air temperature above 32 degrees F (0° C). Temperature of units when laid shall be not less than 20 degrees F (-7° C).

END OF SECTION

**PART 1 - GENERAL**

1.1 DESCRIPTION

- A. CONTRACTOR is to provide labor, demolition, disposal, materials, equipment, supplies and all other necessary appurtenances to replace broken or damaged stone masonry at the project site. This work includes the replacement of existing stone masonry units within the limits of the existing foundation. New foundation block to match the appearance of the existing foundation in color and texture.

1.2 SUMMARY

- A. Section Includes:
  - 1. Concrete masonry units.
  - 2. Building block.

1.3 DEFINITIONS

- A. CMU(s): Concrete masonry unit(s).
- B. Reinforced Masonry: Masonry containing reinforcing steel in grouted cells.

1.4 ACTION SUBMITTALS

- A. Product Data: For each type of product.
- B. Shop Drawings: For reinforcing steel. Detail bending, lap lengths, and placement of unit masonry reinforcing bars. Comply with ACI 315.
- C. Samples for Verification: For each type and color of exposed masonry unit and colored mortar.

1.5 INFORMATIONAL SUBMITTALS

- A. Material Certificates: For each type and size of product. For masonry units, include data on material properties
- B. Mix Designs: For each type of mortar and grout. Include description of type and proportions of ingredients.
  - 1. Include test reports for mortar mixes required to comply with property specification. Test according to ASTM C 109/C 109M for compressive strength, ASTM C 1506 for water retention, and ASTM C 91/C 91M for air content.
  - 2. Include test reports, according to ASTM C 1019, for grout mixes required to comply with compressive strength requirement.

1.6 QUALITY ASSURANCE

- A. Sample Panels: Build sample panels to verify selections made under Sample

## UNIT MASONRY

submittals and to demonstrate aesthetic effects. Comply with requirements in Section 014000 "Quality Requirements" for mockups.

1. Build sample panels for typical exterior wall in sizes approximately 48 inches long by 48 inches high by full thickness

### 1.7 FIELD CONDITIONS

- A. Cold-Weather Requirements: Do not use frozen materials or materials mixed or coated with ice or frost. Do not build on frozen substrates. Remove and replace unit masonry damaged by frost or by freezing conditions. Comply with cold-weather construction requirements contained in TMS 602/ACI 530.1/ASCE 6.
- B. Hot-Weather Requirements: Comply with hot-weather construction requirements contained in TMS 602/ACI 530.1/ASCE 6.

## PART 2 - PRODUCTS

### 2.1 UNIT MASONRY, GENERAL

- A. Masonry Standard: Comply with TMS 602/ACI 530.1/ASCE 6, except as modified by requirements in the Contract Documents.
- B. Defective Units: Referenced masonry unit standards may allow a certain percentage of units to contain chips, cracks, or other defects exceeding limits stated. Do not use units where such defects are exposed in the completed Work and will be within 20 feet (6 m) vertically and horizontally of a walking surface.
- C. Fire-Resistance Ratings: Comply with requirements for fire-resistance-rated assembly designs indicated.
  1. Where fire-resistance-rated construction is indicated, units shall be listed and labeled by a qualified testing agency acceptable to authorities having jurisdiction.

### 2.2 CONCRETE MASONRY UNITS

- A. Shapes: Provide shapes indicated and as follows, with exposed surfaces matching exposed faces of adjacent units unless otherwise indicated.
  1. Provide special shapes for lintels, corners, jambs, sashes, movement joints, headers, bonding, and other special conditions.
- B. Integral Water Repellent: Provide units made with integral water repellent for exposed units
- C. CMUs: ASTM C 90.
  1. Unit Compressive Strength: Provide units with minimum average net-area compressive strength of 2800 psi
  2. Density Classification: Light weight



## UNIT MASONRY

- D. Decorative CMUs: ASTM C 90.
  - 1. Unit Compressive Strength: Provide units with minimum average net-area compressive strength of 2800 psi
  - 2. Density Classification: Light weight.
  - 3. Pattern and Texture:
    - a. Standard pattern, split-ribbed finish as Manufactured by "The Bauer Company" Fluted Brown Concrete CMU

### 2.3 CONCRETE LINTELS

- A. Concrete Lintels: ASTM C 1623, matching CMUs in color, texture, and density classification; and with reinforcing bars indicated. Provide lintels with net-area compressive strength not less than that of CMUs.

### 2.4 BRICK

- A. General: Provide shapes indicated and as follows, with exposed surfaces matching finish and color of exposed faces of adjacent units:
  - 1. For ends of sills and caps and for similar applications that would otherwise expose unfinished brick surfaces, provide units without cores or frogs and with exposed surfaces finished.
  - 2. Provide special shapes for applications where shapes produced by sawing would result in sawed surfaces being exposed to view.
- B. Clay Face Brick: Facing brick complying with ASTM C 216
  - 1. Grade: SW
  - 2. Type: FBX
  - 3. Unit Compressive Strength: Provide units with minimum average net-area compressive strength of 4150 psi
  - 4. Initial Rate of Absorption: Less than 30 g/30 sq. in. (30 g/194 sq. cm) per minute when tested according to ASTM C 67.
  - 5. Efflorescence: Provide brick that has been tested according to ASTM C 67 and is rated "not effloresced."
  - 6. Surface Coating: Brick with colors or textures produced by application of coatings shall withstand 50 cycles of freezing and thawing according to ASTM C 67 with no observable difference in the applied finish when viewed from 10 feet (3 m).
  - 7. Size (Actual Dimensions): 3-5/8 inches (92 mm) wide by 2-1/4 inches (57 mm) high by 7-5/8 inches (194 mm) long.
  - 8. Color and Texture:
    - a. Glen-Gery Corporation – W32 Tawney Beige Modular Size Colored Units

### 2.5 MORTAR AND GROUT MATERIALS

- A. Portland Cement: ASTM C 150/C 150M, Type I or II, except Type III may be used for cold-weather construction. Provide natural color or white cement as required to produce mortar color indicated.

## UNIT MASONRY

- B. Hydrated Lime: ASTM C 207, Type S.
- C. Portland Cement-Lime Mix: Packaged blend of portland cement and hydrated lime containing no other ingredients.
- D. Masonry Cement: ASTM C 91/C 91M.
- E. Mortar Pigments: Natural and synthetic iron oxides and chromium oxides, compounded for use in mortar mixes and complying with ASTM C 979/C 979M. Use only pigments with a record of satisfactory performance in masonry mortar.
- F. Colored Cement Products: Packaged blend made from portland cement and hydrated lime or masonry cement and mortar pigments, all complying with specified requirements, and containing no other ingredients.
  - 1. Colored Portland Cement-Lime Mix:
- G. Aggregate for Mortar: ASTM C 144.
  - 1. For joints less than 1/4 inch (6 mm) thick, use aggregate graded with 100 percent passing the No. 16 (1.18-mm) sieve.
  - 2. White-Mortar Aggregates: Natural white sand or crushed white stone.
  - 3. Colored-Mortar Aggregates: Natural sand or crushed stone of color necessary to produce required mortar color.
- H. Aggregate for Grout: ASTM C 404.
- I. Epoxy Pointing Mortar: ASTM C 395, epoxy-resin-based material formulated for use as pointing mortar for glazed or pre-faced masonry units (and approved for such use by manufacturer of units); in color indicated or, if not otherwise indicated, as selected by Architect from manufacturer's colors.
- J. Cold-Weather Admixture: Nonchloride, noncorrosive, accelerating admixture complying with ASTM C 494/C 494M, Type C, and recommended by manufacturer for use in masonry mortar of composition indicated.
- K. Water-Repellent Admixture: Liquid water-repellent mortar admixture intended for use with CMUs containing integral water repellent from same manufacturer.
- L. Water: Potable.

### 2.6 REINFORCEMENT

- A. Uncoated-Steel Reinforcing Bars: ASTM A 615/A 615M or ASTM A 996/A 996M, Grade 60 (Grade 420).
- B. Masonry-Joint Reinforcement, General: ASTM A 951/A 951M.
  - 1. Interior Walls: Hot-dip galvanized carbon steel.
  - 2. Exterior Walls: [=Hot-dip galvanized carbon steel.

3. Wire Size for Side Rods: 0.187-inch diameter.
4. Wire Size for Cross Rods: 0.187-inch diameter.
5. Wire Size for Veneer Ties: 0.187-inch diameter.
6. Spacing of Cross Rods, Tabs, and Cross Ties: Not more than 16 inches (407 mm) o.c.
7. Provide in lengths of not less than 10 feet (3 m), with prefabricated corner and tee units.

C. Masonry-Joint Reinforcement for Multiwythe Masonry:

1. Adjustable (two-piece) type, either ladder or truss design, with one side rod at each face shell of backing wythe and with separate adjustable ties with pintle-and-eye connections having a maximum horizontal play of 1/16 inch (1.5 mm) and maximum vertical adjustment of 1-1/4 inches (32 mm). Size ties to extend at least halfway through facing wythe but with at least 5/8-inch (16-mm) cover on outside face. Ties have hooks or clips to engage a continuous horizontal wire in the facing wythe.

2.7 TIES AND ANCHORS

- A. General: Ties and anchors shall extend at least 1-1/2 inches (38 mm) into veneer but with at least a 5/8-inch (16-mm) cover on outside face.
- B. Materials: Provide ties and anchors specified in this article that are made from materials that comply with the following unless otherwise indicated:
  1. Hot-Dip Galvanized, Carbon-Steel Wire: ASTM A 82/A 82M, with ASTM A 153/A 153M, Class B-2 coating.

C. Adjustable Masonry-Veneer Anchors:

1. General: Provide anchors that allow vertical adjustment but resist a 100-lbf (445-N) load in both tension and compression perpendicular to plane of wall without deforming or developing play in excess of 1/16 inch (1.5 mm).
2. Fabricate sheet metal anchor sections and other sheet metal parts from 0.075-inch- (1.90-mm-) thick steel sheet, galvanized after fabrication
3. Fabricate wire ties from 0.187-inch- diameter, hot-dip galvanized-steel wire unless otherwise indicated.
4. Screw-Attached, Masonry-Veneer Anchors: Wire tie and a rib-stiffened, sheet metal anchor section.

2.8 EMBEDDED FLASHING MATERIALS

- A. Metal Flashing: Provide metal flashing complying with Section 076200 "Sheet Metal Flashing and Trim" and as follows:
  1. Fabricate metal drip edges from stainless steel. Extend at least 3 inches (76 mm) into wall and 1/2 inch (13 mm) out from wall, with outer edge bent down 30 degrees and hemmed.

## UNIT MASONRY

- B. Flexible Flashing: Use the following unless otherwise indicated:
  - 1. Copper-Laminated Flashing: 7 -oz./sq. ft. copper sheet bonded between two layers of glass-fiber cloth. Use only where flashing is fully concealed in masonry.
- C. Solder and Sealants for Sheet Metal Flashings: As specified in Section 076200 "Sheet Metal Flashing and Trim."
- D. Adhesives, Primers, and Seam Tapes for Flashings: Flashing manufacturer's standard products or products recommended by flashing manufacturer for bonding flashing sheets to each other and to substrates.

### 2.9 MISCELLANEOUS MASONRY ACCESSORIES

- A. Compressible Filler: Premolded filler strips complying with ASTM D 1056, Grade 2A1; compressible up to 35 percent; of width and thickness indicated; formulated from neoprene
- B. Bond-Breaker Strips: Asphalt-saturated felt complying with ASTM D 226/D 226M, Type I (No. 15 asphalt felt).
- C. Weep/Cavity Vent Products: Use the following unless otherwise indicated:
  - 1. Cellular Plastic Weep/Vent: One-piece, flexible extrusion made from UV-resistant polypropylene copolymer, full height and width of head joint and depth 1/8 inch (3 mm) less than depth of outer wythe, in color selected from manufacturer's standard.
- D. Cavity Drainage Material: Free-draining mesh, made from polymer strands that will not degrade within the wall cavity.
  - 1. Configuration: Provide one of the following:
    - a. Strips, full depth of cavity and 10 inches (250 mm) high, with dovetail shaped notches 7 inches (175 mm) deep that prevent clogging with mortar droppings.

### 2.10 MASONRY CLEANERS

- A. Proprietary Acidic Cleaner: Manufacturer's standard-strength cleaner designed for removing mortar/grout stains, efflorescence, and other new construction stains from new masonry without discoloring or damaging masonry surfaces. Use product expressly approved for intended use by cleaner manufacturer and manufacturer of masonry units being cleaned.

2.11 MORTAR AND GROUT MIXES

- A. General: Do not use admixtures, including pigments, air-entraining agents, accelerators, retarders, water-repellent agents, antifreeze compounds, or other admixtures unless otherwise indicated.
  - 1. Do not use calcium chloride in mortar or grout.
  - 2. Use portland cement-lime or masonry cement mortar unless otherwise indicated.
  - 3. Add cold-weather admixture (if used) at same rate for all mortar that will be exposed to view, regardless of weather conditions, to ensure that mortar color is consistent.
  
- B. Preblended, Dry Mortar Mix: Furnish dry mortar ingredients in form of a preblended mix. Measure quantities by weight to ensure accurate proportions, and thoroughly blend ingredients before delivering to Project site.
  
- C. Mortar for Unit Masonry: Comply with ASTM C 270, Proportion Specification. Provide the following types of mortar for applications stated unless another type is indicated or needed to provide required compressive strength of masonry.
  - 1. For masonry below grade or in contact with earth, use Type M.
  - 2. For reinforced masonry, use Type M
  - 3. For exterior, above-grade, load-bearing and nonload-bearing walls and parapet walls; for interior load-bearing walls; for interior nonload-bearing partitions; and for other applications where another type is not indicated, use Type N.
  - 4. For interior nonload-bearing partitions, Type O may be used instead of Type N.
  
- D. Pigmented Mortar: Use colored cement product or select and proportion pigments with other ingredients to produce color required. Do not add pigments to colored cement products
  - 1. Pigments shall not exceed 10 percent of portland cement by weight.
  - 2. Mix to match Architect's sample.
  - 3. Application: Use pigmented mortar for exposed mortar joints with the following units:
    - a. Decorative CMUs.
    - b. Clay face brick.
  
- E. Grout for Unit Masonry: Comply with ASTM C 476.
  - 1. Use grout of type indicated or, if not otherwise indicated, of type (fine or coarse) that will comply with TMS 602/ACI 530.1/ASCE 6 for dimensions of grout spaces and pour height.
  - 2. Provide grout with a slump of 8 to 11 inches (200 to 280 mm) as measured according to ASTM C 143/C 143M.

## UNIT MASONRY

### PART 3 - EXECUTION

#### 3.1 INSTALLATION, GENERAL

- A. Use full-size units without cutting if possible. If cutting is required to provide a continuous pattern or to fit adjoining construction, cut units with motor-driven saws; provide clean, sharp, unchipped edges. Allow units to dry before laying unless wetting of units is specified. Install cut units with cut surfaces and, where possible, cut edges concealed.
- B. Select and arrange units for exposed unit masonry to produce a uniform blend of colors and textures. Mix units from several pallets or cubes as they are placed.
- C. Wetting of Brick: Wet brick before laying if initial rate of absorption exceeds 30 g/30 sq. in. (30 g/194 sq. cm) per minute when tested according to ASTM C 67. Allow units to absorb water so they are damp but not wet at time of laying.

#### 3.2 TOLERANCES

##### A. Dimensions and Locations of Elements:

- 1. For dimensions in cross section or elevation, do not vary by more than plus 1/2 inch (12 mm) or minus 1/4 inch (6 mm).
- 2. For location of elements in plan, do not vary from that indicated by more than plus or minus 1/2 inch (12 mm).
- 3. For location of elements in elevation, do not vary from that indicated by more than plus or minus 1/4 inch (6 mm) in a story height or 1/2 inch (12 mm) total.

##### B. Lines and Levels:

- 1. For bed joints and top surfaces of bearing walls, do not vary from level by more than 1/4 inch in 10 feet (6 mm in 3 m), or 1/2-inch (12-mm) maximum.
- 2. For conspicuous horizontal lines, such as lintels, sills, parapets, and reveals, do not vary from level by more than 1/8 inch in 10 feet (3 mm in 3 m), 1/4 inch in 20 feet (6 mm in 6 m), or 1/2-inch (12-mm) maximum.
- 3. For vertical lines and surfaces, do not vary from plumb by more than 1/4 inch in 10 feet (6 mm in 3 m), 3/8 inch in 20 feet (9 mm in 6 m), or 1/2-inch (12-mm) maximum.
- 4. For conspicuous vertical lines, such as external corners, door jambs, reveals, and expansion and control joints, do not vary from plumb by more than 1/8 inch in 10 feet (3 mm in 3 m), 1/4 inch in 20 feet (6 mm in 6 m), or 1/2-inch (12-mm) maximum.
- 5. For lines and surfaces, do not vary from straight by more than 1/4 inch in 10 feet (6 mm in 3 m), 3/8 inch in 20 feet (9 mm in 6 m), or 1/2-inch (12-mm) maximum.

##### C. Joints:

- 1. For bed joints, do not vary from thickness indicated by more than plus or minus 1/8 inch (3 mm), with a maximum thickness limited to 1/2 inch (12 mm).

## UNIT MASONRY

2. For head and collar joints, do not vary from thickness indicated by more than plus 3/8 inch (9 mm) or minus 1/4 inch (6 mm).
3. For exposed head joints, do not vary from thickness indicated by more than plus or minus 1/8 inch (3 mm).

### 3.3 LAYING MASONRY WALLS

- A. Lay out walls in advance for accurate spacing of surface bond patterns with uniform joint thicknesses and for accurate location of openings, movement-type joints, returns, and offsets. Avoid using less-than-half-size units, particularly at corners, jambs, and, where possible, at other locations.
- B. Bond Pattern for Exposed Masonry: Unless otherwise indicated, lay exposed masonry in running bond; do not use units with less-than-nominal 4-inch (100-mm) horizontal face dimensions at corners or jambs.
- C. Built-in Work: As construction progresses, build in items specified in this and other Sections. Fill in solidly with masonry around built-in items.
- D. Fill space between steel frames and masonry solidly with mortar unless otherwise indicated.
- E. Fill cores in hollow CMUs with grout 24 inches (600 mm) under bearing plates, beams, lintels, posts, and similar items unless otherwise indicated.

### 3.4 MORTAR BEDDING AND JOINTING

- A. Lay CMUs as follows:
  1. Bed face shells in mortar and make head joints of depth equal to bed joints.
  2. Bed webs in mortar in all courses of piers, columns, and pilasters.
  3. Bed webs in mortar in grouted masonry, including starting course on footings.
  4. Fully bed entire units, including areas under cells, at starting course on footings where cells are not grouted.
- B. Lay solid masonry units with completely filled bed and head joints; butter ends with sufficient mortar to fill head joints and shove into place. Do not deeply furrow bed joints or slush head joints.
- C. Tool exposed joints slightly concave when thumbprint hard, using a jointer larger than joint thickness unless otherwise indicated.
- D. Cut joints flush for masonry walls to receive plaster or other direct-applied finishes (other than paint) unless otherwise indicated.

### 3.5 CAVITY WALLS

- A. Bond wythes of cavity walls together as follows:

## UNIT MASONRY

1. Individual Metal Ties: Provide ties as shown installed in horizontal joints, but not less than one metal tie for 1.77 sq. ft. (0.16 sq. m) of wall area spaced not to exceed 24 inches o.c. horizontally and 16 inches (406 mm) o.c. vertically. Stagger ties in alternate courses. Provide additional ties within 12 inches (305 mm) of openings and space not more than 36 inches (915 mm) apart around perimeter of openings. At intersecting and abutting walls, provide ties at no more than 24 inches (610 mm) o.c. vertically.
  2. Masonry-Joint Reinforcement: Installed in horizontal mortar joints.
    - a. Where bed joints of both wythes align, use tab-type reinforcement.
    - b. Where bed joints of wythes do not align, use adjustable-type (two-piece-type) reinforcement[ with continuous horizontal wire in facing wythe attached to ties.
- B. Keep cavities clean of mortar droppings and other materials during construction. Bevel beds away from cavity, to minimize mortar protrusions into cavity. Do not attempt to trowel or remove mortar fins protruding into cavity.
- C. Parge cavity face of backup wythe in a single coat approximately 3/8 inch (10 mm) thick. Trowel face of parge coat smooth.
- D. Installing Cavity Wall Insulation: Place small dabs of adhesive, spaced approximately 12 inches (300 mm) o.c. both ways, on inside face of insulation boards, or attach with plastic fasteners designed for this purpose. Fit courses of insulation between wall ties and other confining obstructions in cavity, with edges butted tightly both ways. Press units firmly against inside wythe of masonry or other construction as shown.

### 3.6 MASONRY-JOINT REINFORCEMENT

- A. General: Install entire length of longitudinal side rods in mortar with a minimum cover of 5/8 inch (16 mm) on exterior side of walls, 1/2 inch (13 mm) elsewhere. Lap reinforcement a minimum of 6 inches (150 mm).
1. Space reinforcement not more than 16 inches (406 mm) o.c.
  2. Space reinforcement not more than 8 inches (203 mm) o.c. in foundation walls and parapet walls.
  3. Provide reinforcement not more than 8 inches (203 mm) above and below wall openings and extending 12 inches (305 mm) beyond openings
- B. Interrupt joint reinforcement at control and expansion joints unless otherwise indicated.
- C. Provide continuity at wall intersections by using prefabricated T-shaped units.
- D. Provide continuity at corners by using prefabricated L-shaped units.

### 3.7 ANCHORING MASONRY TO STRUCTURAL STEEL AND CONCRETE

- A. Anchor masonry to structural steel and concrete, where masonry abuts or faces structural steel or concrete, to comply with the following:



## UNIT MASONRY

1. Provide an open space not less than [1/2 inch (13 mm)] [1 inch (25 mm)] [2 inches (50 mm)] wide between masonry and structural steel or concrete unless otherwise indicated. Keep open space free of mortar and other rigid materials.
2. Anchor masonry with anchors embedded in masonry joints and attached to structure.
3. Space anchors as indicated, but not more than 24 inches (610 mm) o.c. vertically and 36 inches (915 mm) o.c. horizontally.

### 3.8 FLASHING, WEEP HOLES, AND CAVITY VENTS

- A. General: Install embedded flashing and weep holes in masonry at shelf angles, lintels, ledges, other obstructions to downward flow of water in wall, and where indicated. Install cavity vents at shelf angles, ledges, and other obstructions to upward flow of air in cavities, and where indicated.
- B. Install flashing as follows unless otherwise indicated:
  1. Prepare masonry surfaces so they are smooth and free from projections that could puncture flashing. Where flashing is within mortar joint, place through-wall flashing on sloping bed of mortar and cover with mortar. Before covering with mortar, seal penetrations in flashing with adhesive, sealant, or tape as recommended by flashing manufacturer.
  2. At multiwythe masonry walls, including cavity walls, extend flashing through outer wythe, turned up a minimum of 8 inches and through inner wythe to within 1/2 inch (13 mm) of the interior face of wall in exposed masonry. Where interior face of wall is to receive furring or framing, carry flashing completely through inner wythe and turn flashing up approximately 2 inches (50 mm) on interior face.
  3. At lintels and shelf angles, extend flashing a minimum of 6 inches (150 mm) into masonry at each end. At heads and sills, extend flashing 6 inches (150 mm) at ends and turn up not less than 2 inches (50 mm) to form end dams.
  4. Install metal drip edges beneath flexible flashing at exterior face of wall. Stop flexible flashing 1/2 inch (13 mm) back from outside face of wall, and adhere flexible flashing to top of metal drip edge.
  5. Install metal flashing termination beneath flexible flashing at exterior face of wall. Stop flexible flashing 1/2 inch (13 mm) back from outside face of wall, and adhere flexible flashing to top of metal flashing termination.
- C. Install weep holes in exterior wythes and veneers in head joints of first course of masonry immediately above embedded flashing.
  1. Use specified weep/cavity vent products or open head joints to form weep holes.
  2. Space weep holes 24 inches (600 mm) o.c. unless otherwise indicated.
  3. Cover cavity side of weep holes with plastic insect screening at cavities insulated with loose-fill insulation.
- D. Install cavity vents in head joints in exterior wythes at spacing indicated. Use [open head joints to form cavity vents].
  1. Close cavities off vertically and horizontally with blocking in manner indicated. Install through-wall flashing and weep holes above horizontal blocking.

## UNIT MASONRY

### 3.9 REINFORCED UNIT MASONRY INSTALLATION

- A. Temporary Formwork and Shores: Construct formwork and shores as needed to support reinforced masonry elements during construction.
  - 1. Construct formwork to provide shape, line, and dimensions of completed masonry as indicated. Make forms sufficiently tight to prevent leakage of mortar and grout. Brace, tie, and support forms to maintain position and shape during construction and curing of reinforced masonry.
  - 2. Do not remove forms and shores until reinforced masonry members have hardened sufficiently to carry their own weight and that of other loads that may be placed on them during construction.
- B. Placing Reinforcement: Comply with requirements in TMS 602/ACI 530.1/ASCE 6.
- C. Grouting: Do not place grout until entire height of masonry to be grouted has attained enough strength to resist grout pressure.
  - 1. Comply with requirements in TMS 602/ACI 530.1/ASCE 6 for cleanouts and for grout placement, including minimum grout space and maximum pour height.
  - 2. Limit height of vertical grout pours to not more than 60 inches

### 3.10 FIELD QUALITY CONTROL

- A. Testing and Inspecting: Owner will engage special inspectors to perform tests and inspections and prepare reports. Allow inspectors access to scaffolding and work areas as needed to perform tests and inspections. Retesting of materials that fail to comply with specified requirements shall be done at Contractor's expense.
- B. Inspections: Special inspections according to Level B in TMS 402/ACI 530/ASCE 5.
  - 1. Begin masonry construction only after inspectors have verified proportions of site-prepared mortar.
  - 2. Place grout only after inspector has verified compliance of grout spaces and of grades, sizes, and locations of reinforcement.
  - 3. Place grout only after inspectors have verified proportions of site-prepared grout.
- C. Testing Prior to Construction: One set of tests.
- D. Testing Frequency: One set of tests for each 5000 sq. ft. (464 sq. m) of wall area or portion thereof.
- E. Clay Masonry Unit Test: For each type of unit provided, according to ASTM C 67 for compressive strength.
- F. Concrete Masonry Unit Test: For each type of unit provided, according to ASTM C 140 for compressive strength.
- G. Mortar Aggregate Ratio Test (Proportion Specification): For each mix provided, according to ASTM C 780.

## UNIT MASONRY

- H. Grout Test (Compressive Strength): For each mix provided, according to ASTM C 1019.

### 3.11 REPAIRING, POINTING, AND CLEANING

- A. In-Progress Cleaning: Clean unit masonry as work progresses by dry brushing to remove mortar fins and smears before tooling joints.
- B. Final Cleaning: After mortar is thoroughly set and cured, clean exposed masonry as follows:
  1. Remove large mortar particles by hand with wooden paddles and nonmetallic scrape hoes or chisels.
  2. Test cleaning methods on sample wall panel; leave one-half of panel uncleaned for comparison purposes.
  3. Protect adjacent surfaces from contact with cleaner.
  4. Wet wall surfaces with water before applying cleaners; remove cleaners promptly by rinsing surfaces thoroughly with clear water.
  5. Clean brick by bucket-and-brush hand-cleaning method described in BIA Technical Notes 20.
  6. Clean masonry with a proprietary acidic cleaner applied according to manufacturer's written instructions.

### 3.12 MASONRY WASTE DISPOSAL

- A. Waste Disposal as Fill Material: Dispose of clean masonry waste, including excess or soil-contaminated sand, waste mortar, and broken masonry units, by crushing and mixing with fill material as fill is placed.
  1. Do not dispose of masonry waste as fill within 18 inches (450 mm) of finished grade.
- B. Masonry Waste Recycling: Return broken CMUs not used as fill to manufacturer for recycling.
- C. Excess Masonry Waste: Remove excess clean masonry waste that cannot be used as fill, as described above or recycled, and other masonry waste, and legally dispose of off Owner's property.

END OF SECTION

**UNIT MASONRY**

THIS PAGE LEFT BLANK INTENTIONALLY

**DIVISION 05**

**METALS**

**THIS PAGE LEFT BLANK INTENTIONALLY**

**SECTION 05 12 00**  
**STRUCTURAL STEEL FRAMING**

**PART 1 - GENERAL**

1.1 SUMMARY

- A. The extent of structural steel work is indicated on the Plans, including schedules, notes, and details to show size and location of members, typical connections, and type of steel required.

1.2 QUALITY ASSURANCE (NOT USED)

1.3 DEFINITIONS (NOT USED)

1.4 SUBMITTALS

- A. For information only, submit two (2) copies of producer's or manufacturer's specifications and installation instructions for the following products including laboratory test reports and other data as may be required to show compliance with these specifications (including specified standards). Indicate by transmittal that copy of each applicable instruction has been distributed to Fabricators, Installers, and Erectors.
1. Structural Steel, including certified copies of mill reports covering the chemical and physical properties.
  2. High-strength bolts including nuts and washers.
  3. Unfinished bolts and nuts.
  4. Structural steel primer paint.
  5. Shrinkage-resistant grout.
  6. Slide bearings.
- B. Submit shop drawings, prepared by a professional engineer registered in the State of Kentucky, including complete details and schedules for fabrication and shop assembly of members, connections, and details. Also include schedules, procedures, and diagrams showing the sequence of erection.
- C. Include details of cuts, connections, camber, holes, and other pertinent data. Indicate welds by standard AWS symbols and show size, length, and type of each weld.
- D. Provide setting drawings, templates, and directions for the installation of anchor bolts and other anchorages to be installed by others.

1.5 WARRANTY (NOT USED)

1.6 RELATED WORK SPECIFIED ELSEWHERE

- A. Cast-In-Place Concrete: Section 03 3000.
- B. Mortaring and Grouting: Section 04 0511.
- C. Interior Painting: Section 09 9123.

1.7 REFERENCE STANDARDS

- A. Unless otherwise specified, the Work for this Section shall conform to the applicable portions of the following Standard Specifications:

## STRUCTURAL STEEL FRAMING

1. AISC: American Institute of Steel Construction.
2. ASTM: American Society for Testing and Materials.
3. AWS: American Welding Society.

### 1.8 CODES AND STANDARDS

- A. Comply with the provisions of the following, except as otherwise indicated.
  1. AISC: "Code of Standard Practice for Steel Buildings and Bridges."
  2. AISC: "Specifications for the Design, Fabrication, and Erection of Structural Steel for Buildings," including the "Commentary and Supplements" thereto as issued.
  3. AISC: "Specifications for Structural Joints using ASTM A325 or A490 Bolts" approved by the Research Council on Riveted and Bolted Structural Joints of the Engineering Foundation.
  4. AWS D1.1: "Structural Welding Code."
  5. ASTM A6: "General Requirements for Delivery of Rolled Steel Plates, Shapes, Sheet Piling and Bars for Structural Use."

### 1.9 QUALIFICATIONS FOR WELDING WORK

- A. Qualify welding processes and welding operators in accordance with the AWS "Standard Qualification Procedure."
- B. Provide certification that welders to be employed in the work have satisfactorily passed AWS qualification tests within the previous twelve (12) months.
- C. If recertification of welders is required, retesting will be the Contractor's responsibility.

### 1.10 DESIGN OF MEMBERS AND CONNECTIONS

- A. All details indicated on the Plans are typical; similar details apply to similar conditions, unless otherwise indicated. Verify dimensions at the site whenever possible without causing delay in the Work.
- B. Connection details not shown on the plans shall be designed in accordance with the most current addition of the AISC "Manual of Steel Construction."
- C. Promptly notify the ENGINEER whenever design of members and connections for any portion of the structure is not clearly indicated.

### 1.11 ALLOWABLE TOLERANCES

- A. Overall Length:
  1. Members with both ends milled for contact bearing:  $\pm 1/32$  inch (0.8 mm).
  2. Members without ends milled for contact bearing which are framed to other members:
    - a. 30 feet (9 m) or less in length  $\pm 1/16$  inch (1.5 mm).
    - b. Over 30 feet (9 m) in length  $\pm 1/8$  inch (3 mm).
- B. Straightness:
  1. Structural members may vary from straightness within the tolerances allowed for wide flange shapes by ASTM Specification A6, except that the tolerance on deviation from straightness of compression members is 1/1,000 of the axial length between points which are to be laterally supported.



## STRUCTURAL STEEL FRAMING

2. Completed members should be free from twists, bends and open joints. Sharp kinks or bends are cause for rejection of material.
  - C. Individual pieces shall be erected so that the deviation from plumb, level and alignment shall not exceed 1:500.
- 1.12 SOURCE QUALITY CONTROL
- A. Materials and fabrication procedures are subject to inspection and tests in the mill, shop, and field, conducted by a qualified inspection agency. Such inspections and tests will not relieve the CONTRACTOR of responsibility for providing materials and fabrication procedures in compliance with specified requirements.
  - B. Promptly remove and replace materials or fabricated components which do not comply.
- 1.13 DELIVERY, STORAGE, AND HANDLING
- A. Deliver materials to the site at such intervals to insure uninterrupted progress of the Work.
  - B. Store materials to permit easy access for inspection and identification. Keep steel members off the ground, using pallets, platforms, or other supports. Protect steel members and packaged materials from erosion and deterioration.
  - C. Do not store materials on the structure in a manner that might cause distortion or damage to the members of the supporting structures. Repair or replace damaged materials or structures as directed by the ENGINEER.
- 1.14 SEQUENCING WITH RELATED WORK
- A. Supply fabricated structural steel members and/or accessories to be installed by related Work. Bearing plates shall be furnished complete with anchor bolts, washers, nuts and setting diagrams or templates.
- 1.15 ENVIRONMENTAL REQUIREMENTS
- A. Allowances shall be made during erection of structural steel for ambient air temperatures specified under Article 3.07 of this Section.

## PART 2 - PRODUCTS

### 2.1 MANUFACTURERS (NOT USED)

### 2.2 STRUCTURAL STEEL

- A. Rolled Steel Wide Flange and Tee Shapes: ASTM A 992.
- B. Other Rolled Steel Plates, Shapes, and Bars: ASTM A572, G50, unless otherwise indicated on the plans.
- C. Hollow Structural Sections: ASTM A500, Gr B.
- D. Steel Pipe: ASTM A53, Type E or S, Grade B.
- E. Anchor Bolts: ASTM A307, nonheaded type unless otherwise indicated on the

## STRUCTURAL STEEL FRAMING

Plans.

### 2.3 WASHERS, BOLTS, AND NUTS

- A. Washers:
  - 1. ASTM F436
- B. Bolts and Nuts:
  - 1. Standard: Grade A ASTM A307, with nuts conforming to Grade A ASTM A563.
  - 2. High Strength: Type 1 ASTM A325, with heavy hex nuts conforming to Grade DH ASTM A563.
  - 3. Alloy Steel: Type 1 ASTM A490, with heavy hex ASTM A194.

### 2.4 MISCELLANEOUS STRUCTURAL ITEMS

- A. Electrodes for Welding: Comply with AWS Code; Use E 70 XX Series.
- B. Structural Steel Primer Paint: Inorganic Zinc-Rich Epoxy Primer
- C. Nonmetallic, Nonshrink Grout: Premixed, nonmetallic, noncorrosive, nonstaining product containing selected silica sands, Portland cement, shrinkage compensating agents, plasticizing and water reducing agents, complying with CRD-C588, Type A.

### 2.5 SHOP FABRICATION AND ASSEMBLY

- A. Fabricate and assemble structural assemblies in the shop to the greatest extent possible. Fabricate items of structural steel in accordance with AISC Specifications and as indicated on the final shop drawings. Provide camber in structural members where indicated on the Plans.
- B. Properly mark and match-mark materials for field assembly. Fabricate for delivery sequence which will expedite erection and minimize field handling of materials.
- C. Where finishing is required, complete the assembly, including welding of units before start of finishing operations. Provide finish surfaces of members exposed in the final structure free of markings, burrs, and other defects.

### 2.6 CONNECTIONS

- A. Weld or bolt shop connections as indicated on the Plans.
- B. Bolt field connections except where welded connections or other connections are specified.
- C. Provide high-strength threaded fasteners for all principal bolted connections, except where unfinished bolts are indicated on the Plans.
- D. Provide unfinished threaded fasteners for only the bolted connections of secondary framing members to primary members (including purlins, girts, and other framing members taking only nominal stresses) and for temporary bracing to facilitate erections.
- E. Install high-strength threaded fasteners in accordance with AISC "Specifications for Structural Joints using ASTM A325 or A490 Bolts."

## STRUCTURAL STEEL FRAMING

- F. Comply with AWS Code for procedures, appearance, quality of welds, and methods used in correcting welding work.
- G. Assemble and weld built-up sections by methods which will produce true alignment of axes without warp.

### 2.7 HOLES FOR OTHER WORK

- A. Provide holes required for securing other Work to structural steel framing, and for the passage of other Work through steel framing members as indicated on the Plans and/or final Shop Drawings. Provide threaded nuts welded to framing, and other specialty items as indicated on the Plans, and/or final shop drawings to receive other Work.
- B. Cut, drill or punch holes perpendicular to metal surfaces. Do not flame cut holes or enlarge holes by burning. Drill holes in bearing plates.

### 2.8 SHOP PAINTING

- A. Shop paint structural steel work, except those members or portions of members to be embedded in concrete or mortar or that is to be galvanized. Paint embedded steel which is partially exposed on portions which are exposed and initial two (2) inches (50 mm) of embedded areas only.
- B. Do not paint surfaces which are to be welded or high-strength bolted with friction-type connections.
- C. After inspection and before shipping, clean all steel work whether painted or not. Remove loose rust, loose mill scale, spatter, slag, or flux deposits. Clean steel in accordance with Steel Structures Painting Council (SSPC) SP-2 "Hand Tool Cleaning" and SP-3 "Power Tool Cleaning."
- D. Immediately after surface preparation, apply structural steel primer paint in accordance with the manufacturer's instructions and at a rate to provide a uniform dry film thickness at 2.0 mils (50  $\mu$ m). Use painting methods which will result in full coverage of joints, corners, edges, and all exposed surfaces.
- E. Coordinate all cleaning, surface preparation and painting in accordance with the final coating system specified on the drawings and Section 09 9123.

## PART 3 - EXECUTION

### 3.1 CONTRACTOR'S VERIFICATION

- A. CONTRACTOR and erector must examine the areas and conditions under which structural steel work is to be installed and notify the ENGINEER, in writing, of conditions detrimental to the proper and timely completion of the Work. Do not proceed with the work until unsatisfactory conditions have been corrected in a manner acceptable to the CONTRACTOR and erector.
- B. The inspection and verification of construction in place shall be sufficiently in advance of steel erection to allow for possible correction of the construction in place or fabrication. If the construction in place is not inspected by the CONTRACTOR prior to erection, the CONTRACTOR shall be responsible for removing and resetting construction in place or revisions in fabrication to correct

## STRUCTURAL STEEL FRAMING

discrepancies.

### 3.2 ERECTION - GENERAL

- A. Comply with the AISC Specifications and Code of Standard Practice, and as herein specified.

### 3.3 TEMPORARY SHORING AND BRACING

- A. Provide temporary shoring and bracing members with connections of sufficient strength to bear imposed loads. Remove temporary members and connections when permanent members are in place and final connections are made. Provide temporary guy lines to achieve proper alignment of the structures as erection proceeds.

### 3.4 TEMPORARY PLANKING

- A. Provide temporary planking and working platforms as necessary to effectively complete the Work.

### 3.5 ANCHOR BOLTS

- A. Furnish anchor bolts and other connectors required for securing structural steel to foundations.
- B. Furnish templates and devices as necessary for presetting bolts and other anchors to accurate locations. Templates shall be 1/8" (3 mm) thick (min) steel plate.

### 3.6 SETTING BASES AND BEARING PLATES

- A. Clean concrete bearing surfaces of bond-reducing materials and roughen to improve bond to surfaces. Clean the bottom surface of base and bearing plates.
- B. Set loose and attached base plates and bearing plates for structural members on wedges or other adjusting devices.
- C. Tighten the anchor bolts after the supported members have been positioned and plumbed. Do not remove wedges or shims, but if protruding, cut off flush with the edge of the base or bearing plate prior to packing with grout.
- D. Pack grout solidly between bearing surfaces and bases or plates to ensure that no voids remain. Finish exposed surfaces, protect installed materials, and allow to cure in strict compliance with the manufacturer's installations, or as otherwise required.

### 3.7 FIELD ASSEMBLY

- A. Set structural frames accurately to the lines and elevations indicated. Align and adjust the various members forming a part of a complete frame or structure before permanently fastening. Before assembly, clean bearing surfaces and other surfaces which will be in permanent contact. Perform necessary adjustments to compensate for discrepancies in elevations and alignment.
- B. Level and plumb individual members of the structure as specified in Article 1.07 of this Section unless otherwise specified by AISC tolerances.
- C. Establish required leveling and plumbing measurements on the mean operating

## STRUCTURAL STEEL FRAMING

temperature of the structure. Make allowances for the difference between temperature at time of erection and the mean temperature at which the structure will be when completed and in service.

- D. Splice members only where indicated on the Plans and/or final Shop Drawings.
- E. Erection bolts on exposed welded construction, shall be removed and holes filled with plug welds and ground smooth at exposed surfaces.
- F. Comply with AISC Specifications for bearing, adequacy of temporary connections, alignment, and the removal of paint on surfaces adjacent to field welds.
- G. Do not enlarge undersized holes in members by burning or by the use of drift pins, except in secondary bracing members. Ream holes that must be enlarged to admit bolts.
- H. Do not use cutting torches in the field for correcting fabrication errors in the structural framing. Cutting will be permitted only on secondary members which are not under stress, as acceptable to the ENGINEER. Finish gas-cut sections equal to a sheared appearance when field cutting is permitted.

### 3.8 TOUCH-UP PAINTING

- A. Immediately after erection clean field welds, bolted connections, and abraded areas of the shop paint. Apply paint to exposed areas with the same material as used for shop painting. Apply by brush or spray to provide a minimum dry film thickness of 2.0 mils (50  $\mu\text{m}$ ).

### 3.9 FIELD QUALITY CONTROL

- A. General:
  - 1. The OWNER may engage an independent testing and inspection agency to inspect high-strength bolted connections and welded connections and to perform tests and prepare test reports. Inspections will meet the requirements of the current building code at the place of the Work.
  - 2. The testing agency shall conduct and interpret the tests and state in each report whether the test specimens comply with the requirements, and specifically state any deviations therefrom.
  - 3. Provide access for the testing agency to places where structural steel work is being fabricated or produced so that required inspection and testing can be accomplished.
  - 4. The testing agency may inspect structural steel at the plant before shipment; however, the ENGINEER reserves the right, at any time before final acceptance to reject material not complying with specified requirements.
  - 5. CONTRACTOR shall correct deficiencies in structural steel work which inspections and laboratory test reports have indicated to be not in compliance with requirements. Performance of additional tests as may be necessary to reconfirm any noncompliance of the original Work, and as may be necessary to show compliance of corrected work will be at the CONTRACTOR's expense.
  - 6. Work determined to be defective by the ENGINEER and/or local agencies regardless of all previous inspections, shall be corrected to the

## STRUCTURAL STEEL FRAMING

satisfaction of the ENGINEER at no extra cost to the OWNER. The CONTRACTOR shall be responsible for the cost and delay of replacing defective Work both in regard to his own Contract and as such cost or delay affects the Work of others.

- B. Connections:
1. Inspect shop bolted connections in accordance with AISC Specifications.
  2. Inspect and test not less than five (5) percent of the shop and field welds during fabrication and erection of structural steel assemblies as follows:
    - a. Certify welders and conduct inspections and tests as required.
    - b. Record types and locations of all defects found in the Work.
    - c. Record Work required and performed to correct deficiencies.
    - d. Perform visual inspection of all welds complying with ASTM E164.
  3. Inspection of field bolted connections will be in accordance with AISC Specifications.

END OF SECTION

**SECTION 05 50 00  
METAL FABRICATIONS**

**PART 1      GENERAL**

1.1 SCOPE OF WORK

- A. This Section includes shop fabricated steel and aluminum items as indicated on the Plans complete with materials, fabrication and installation including but not limited to the following:
1. Shelf Angles.
  2. Metal Ladders.
  3. Ladder Safety Cages.
  4. Metal Bollards.
  5. Loose Bearing and Leveling Plates.
  6. Steel Lintels.
  7. Anchor Bolts and Steel Pipe Sleeves.
  8. Monorail Beams and Associated Supports.
  9. Platforms, Walkways and Miscellaneous Metal Structures.

1.2 RELATED WORK SPECIFIED ELSEWHERE

- A. Section 03 3000: Cast-in-Place Concrete.
- B. Section 04 2000: Unit Masonry.

1.3 QUALITY ASSURANCE

- A. Reference Standards:
1. AAMA 611 - Voluntary Specification for Anodized Architectural Aluminum; American Architectural Manufacturers Association; 1998.
  2. ANSI A14.3 - American National Standard for Ladders -- Fixed -- Safety Requirements; 2002.
  3. ASTM A 36/A 36M - Standard Specification for Carbon Structural Steel; 2005.
  4. ASTM A 53/A 53M - Standard Specification for Pipe, Steel, Black and Hot-Dipped, Zinc-Coated, Welded and Seamless; 2005.
  5. ASTM A 123/A 123M - Standard Specification for Zinc (Hot-Dip Galvanized) Coatings on Iron and Steel Products; 2002.
  6. ASTM A 153/A 153M - Standard Specification for Zinc Coating (Hot-Dip) on Iron and Steel Hardware; 2005.
  7. ASTM A 283/A 283M - Standard Specification for Low and Intermediate Tensile Strength Carbon Steel Plates; 2003.
  8. ASTM A 307 - Standard Specification for Carbon Steel Bolts and Studs, 60,000 PSI Tensile Strength; 2004.
  9. ASTM A 325 - Standard Specification for Structural Bolts, Steel, Heat Treated, 120/105 ksi Minimum Tensile Strength; 2004b.
  10. ASTM A 500 - Standard Specification for Cold-Formed Welded and Seamless Carbon Steel Structural Tubing in Rounds and Shapes; 2003a.
  11. ASTM A 501 - Standard Specification for Hot-Formed Welded and

## METAL FABRICATIONS

Seamless Carbon Steel Structural Tubing; 2001 (Reapproved 2005).ASTM B 209 - Standard Specification for Aluminum and Aluminum-Alloy Sheet and Plate; 2004.

12. ASTM B 210 - Standard Specification for Aluminum and Aluminum-Alloy Drawn Seamless Tubes; 2004.
13. AWS A2.4 - Standard Symbols for Welding, Brazing, and Nondestructive Examination; American Welding Society; 1998.
14. AWS D1.1/D1.1M - Structural Welding Code - Steel; American Welding Society; 2006.
15. SSPC-Paint 15 - Steel Joist Shop Primer; Society for Protective Coatings; 1999 (Ed. 2004).
16. SSPC-Paint 20 - Zinc-Rich Primers (Type I, "Inorganic," and Type II, "Organic"); Society for Protective Coatings; 2002 (Ed. 2004).
17. SSPC-SP 2 - Hand Tool Cleaning; Society for Protective Coatings; 1982 (Ed. 2004).

### B. Manufacturer's Qualifications:

1. Design connections and components not detailed on drawings under direct supervision of a Professional Structural Engineer experienced in design of this Work and licensed in the State of Kentucky.

### C. Inspection:

1. Work done in accordance with this specification shall be subject to inspection. OWNER or ENGINEER shall have access to all places of manufacture where materials are being produced or fabricated, or where tests are being conducted and shall be accorded full facilities for inspection and observation.

## 1.4 SUBMITTALS

### A. Shop Drawings and Product Data:

1. Shop Drawings: Indicate profiles, sizes, connection attachments, reinforcing, anchorage, size and type of fasteners, and accessories. Include erection drawings, elevations, and details where applicable.
  - a. Indicate welded connections using standard AWS A2.4 welding symbols. Indicate net weld lengths.
2. Provide product data for all paints and coatings/

### B. Certificates:

1. Welders' Certificates: Submit certification for welders employed on the project, verifying AWS qualification within the previous 12 months.

## 1.5 PROJECT CONDITIONS

- A. Field Measurements: Verify actual locations of walls and other construction contiguous with metal fabrications by field measurements before fabrication.



## METAL FABRICATIONS

### 1.6 COORDINATION

- A. Coordinate selection of shop primers with topcoat to be applied over them. Comply with paint and coating manufacturer's written recommendations to ensure that shop primers and topcoats are compatible with one another.
- B. Coordinate installation of anchorages and steel weld plates, and angles for casting into concrete. Furnish setting drawings, templates and directions for installing anchorages, including sleeves, concrete inserts, anchor bolts, and items with integral anchors that are to be embedded into concrete or masonry. Deliver such items to Project site in time for installation.

## **PART 2      PRODUCTS**

### 2.1 MATERIALS – GENERAL

- A. Metal Surfaces: Provide materials with smooth, flat surfaces unless otherwise indicated. For metal fabrication exposed to view in the completed Work, provide materials without seam marks, roller marks, rolled frame names or blemishes.

### 2.2 MATERIALS - STEEL

- A. Steel Sections: ASTM A36/A36M.
- B. Steel Tubing: ASTM A500, Grade B cold-formed structural tubing.
- C. Plates: ASTM A283.
- D. Pipe: ASTM A53/A53M, Grade B Schedule 40, black finish.
- E. Bolts, Nuts, and Washers: ASTM A325 (ASTM A325M), Type 1, galvanized to ASTM A153/A153M where connecting galvanized components.
- F. Welding Materials: AWS D1.1; type required for materials being welded.
- G. Shop and Touch-Up Primer: SSPC-Paint 15, complying with VOC limitations of authorities having jurisdiction.
- H. Touch-Up Primer for Galvanized Surfaces: SSPC-Paint 20, Type I - Inorganic, complying with VOC limitations of authorities having jurisdiction.

### 2.2 MATERIALS – Z ALLOY

- A. Tubing: Nickle Copper alloy by Johnson Water Screens/Bilfinger Water Technologies, New Brighton, MN.
- B. Plates: Nickle Copper alloy by Johnson Water Screens/Bilfinger Water

## METAL FABRICATIONS

Technologies, New Brighton, MN.

- C. Bolts, Nuts, and Washers: ASTM A193/A194 (ASTM A193M/A194M), Type B8, Class 2. Z Alloy manufacturer to confirm compatibility of stainless steel fasteners with z alloy components.
- D. All components shall be NSF 61 compliant.

### 2.3 MATERIALS - ALUMINUM

- A. Extruded Aluminum: ASTM B221 (ASTM B221M), 6063 alloy, T6 temper.
- B. Aluminum-Alloy Drawn Seamless Tubes: ASTM B210 (ASTM 210M), 6063 alloy, T6 temper.
- C. Bolts, Nuts, and Washers: A316 Stainless steel.
- D. Welding Materials: AWS D1.1; type required for materials being welded.

### 2.4 FASTENERS

- A. Anchor Bolts: ASTM F 1554, grade 36, of dimensions indicated, with nuts ASTM A 563 and flat washers
- B. Eye bolts: ASTM A489
- C. Post installed anchors: Stainless Steel alloy Group 2 (A4) ASTM 593 and nuts ASTM F594.

### 2.5 FABRICATION

- A. Fit and shop assemble items in largest practical sections, for delivery to site.
- B. Continuously seal joined members by continuous welds.
- C. Grind exposed joints flush and smooth with adjacent finish surface. Make exposed joints butt tight, flush, and hairline. Ease exposed edges to small uniform radius.
- D. Exposed Mechanical Fastenings: Flush countersunk screws or bolts; unobtrusively located; consistent with design of component, except where specifically noted otherwise.
- E. Supply components required for anchorage of fabrications. Fabricate anchors and related components of same material and finish as fabrication, except where specifically noted otherwise.

## METAL FABRICATIONS

### 2.6 FABRICATED ITEMS

- A. Ladders: Steel; in compliance with ANSI A14.3; with mounting brackets and attachments; galvanized finish.
  - 1. Side Rails: 1/2 x 2½ inches members spaced at 20 inches.
  - 2. Rungs: one inch diameter solid round bar spaced 12 inches on center.
  - 3. Space rungs 7 inches from wall surface.
  - 4. Fall Protection: All ladders shall be equipped with a LAD-SAF system cable system manufactured by DBI Sala/Capital Safety. The LAD-SAF system shall extend a minimum of 5.5 feet above the top of the platform/floor elevation. The extension may be accomplished with an extended ladder, or by a telescoping extension by DBI Sala/Capital Safety, as shown on the drawings.
- B. Telescopic Steel Columns: Steel pipe; galvanized finish.
  - 1. Diameter: 3 inch.
  - 2. Height: 5.5 to 9 feet.
- C. Bollards: Steel pipe, concrete filled, crowned cap, as detailed; prime paint finish.
- D. Ledge Angles, Shelf Angles, Channels, and Plates Not Attached to Structural Framing: For support of metal decking; prime paint finish.
- E. Lintels: As detailed; galvanized finish.
- F. Door Frames for Overhead Door Openings, Wall Openings, and Louver openings: Channel, Angle, and plate sections; galvanized finish.
- G. Hanger supports and embedded plates for precast planks: A 316 Stainless Steel.

### 2.7 FINISHES - STEEL

- A. Prime paint all steel items unless items are to be embedded in concrete or masonry and lintels. Items embedded in concrete or masonry and lintels shall be galvanized.
  - 1. Prepare surfaces to be primed in accordance with SSPC-SP2.
  - 2. Clean surfaces of rust, scale, grease, and foreign matter prior to finishing.
  - 3. Prime Painting: One coat.
- B. Galvanizing:
  - 1. Structural Steel Members: Galvanize after fabrication to ASTM A 123/A 123M requirements.
  - 2. Non-structural Items: Galvanize after fabrication to ASTM A 123/A 123M requirements.

### 2.8 FINISHES - ALUMINUM

## METAL FABRICATIONS

- A. Exterior Aluminum Surfaces: Class I natural anodized.
- B. Interior Aluminum Surfaces: Class I natural anodized.
- C. Apply one coat of bituminous paint to concealed aluminum surfaces in contact with cementitious or dissimilar materials.

### 2.9 FABRICATION TOLERANCES

- A. Squareness:.....1/8 inch maximum difference in diagonal measurements
- B. Maximum Offset Between Faces:.....1/16 inch
- C. Maximum Misalignment of Adjacent Members:.....1/16 inch
- D. Maximum Bow:.....1/8 inch in 48 inches
- E. Maximum Deviation From Plane:.....1/16 inch in 48 inches

## **PART 3      EXECUTION**

### 3.1 EXAMINATION

- A. Verify that field conditions are acceptable and are ready to receive work.

### 3.2 PREPARATION

- A. Clean and strip primed steel items to bare metal where site welding is required.
- B. Supply setting templates to the appropriate entities for steel items required to be cast into concrete or embedded in masonry.

### 3.3 INSTALLATION

- A. Install items plumb and level, accurately fitted, free from distortion or defects.
- B. Provide for erection loads, and for sufficient temporary bracing to maintain true alignment until completion of erection and installation of permanent attachments.
- C. Field weld components indicated.
- D. Perform field welding in accordance with AWS D1.1.
- E. Obtain approval prior to site cutting or making adjustments not scheduled.

## METAL FABRICATIONS

- F. After erection, prime welds, abrasions, and surfaces not shop primed or galvanized, except surfaces to be in contact with concrete.

### 3.4 ERECTION TOLERANCES

- A. Maximum Variation From Plumb:.....1/4 inch per story, non-cumulative
- B. Maximum Offset From True Alignment:.....1/4 inch
- C. Maximum Out-of-Position:.....1/4 inch

END OF SECTION

**METAL FABRICATIONS**

**THIS PAGE LEFT BLANK INTENTIONALLY**

**SECTION 05 52 13  
PIPE RAILINGS**

**PART 1   GENERAL**

1.1    SUMMARY

- A.    Section Includes:
  - 1.    Aluminum pipe railings.

1.2    ACTION SUBMITTALS

- A.    Product Data: For the following:
  - 1.    Manufacturer's product lines of mechanically connected railings.
  - 2.    Railing brackets.
  - 3.    Grout, anchoring cement, and paint products.
- B.    Shop Drawings: Include plans, elevations, sections, details, and attachments to other work.
- C.    Samples: For each type of exposed finish required.
- D.    Retain "Delegated-Design Submittal" Paragraph below if design services have been delegated to Contractor.
- E.    Delegated-Design Submittal: For railings, including analysis data signed and sealed by the qualified professional engineer responsible for their preparation.

1.3    INFORMATIONAL SUBMITTALS

- A.    Product Test Reports: For pipe and tube railings, for tests performed by a qualified testing agency, according to ASTM E 894 and ASTM E 935.

**PART 2   PRODUCTS**

2.1    MANUFACTURERS

- A.    Aluminum Pipe and Tube Railings:
  - 1.    Manufacturers: Subject to compliance with requirements, available manufacturers offering products that may be incorporated into the Work include, but are not limited to, the following:
    - a.    ATR Technologies, Inc.
    - b.    Blum, Julius & Co., Inc.
    - c.    Braun, J. G., Company; The Wagner Companies.
    - d.    CraneVeyor Corp.
    - e.    Hollaender Manufacturing Company.
    - f.    Kee Industrial Products, Inc.
    - g.    Moultrie Manufacturing Company.

## PIPE RAILINGS

- h. Sterling Dula Architectural Products, Inc./ KaneSterling.
- i. Superior Aluminum Products, Inc.
- j. Thompson Fabricating, LLC.
- k. Tri Tech, Inc.
- l. Tubular Specialties Manufacturing, Inc.
- m. Tuttle Railing Systems.
- n. Wagner, R & B, Inc.

### 2.2 PERFORMANCE REQUIREMENTS

- A. Delegated Design: Engage a qualified professional engineer, as defined in Section 01 4000 "Quality Requirements," to design railings, including attachment to building construction.
- B. Structural Performance: Railings, including attachment to building construction, shall withstand the effects of gravity loads and the following loads and stresses within limits and under conditions indicated:
  - 1. Handrails and Top Rails of Guards:
    - a. Uniform load of 50 lbf/ ft. (0.73 kN/m) applied in any direction.
    - b. Concentrated load of 200 lbf (0.89 kN) applied in any direction.
    - c. Uniform and concentrated loads need not be assumed to act concurrently.

### 2.3 METALS, GENERAL

- A. Brackets, Flanges, and Anchors: Cast or formed metal of same type of material and finish as supported rails unless otherwise indicated.
  - 1. Provide type of bracket with predrilled hole for exposed bolt anchorage and that provides 1-1/2-inch (38-mm) clearance from inside face of handrail to finished wall surface.

### 2.4 ALUMINUM

- A. Aluminum, General: Provide alloy and temper recommended by aluminum producer and finisher for type of use and finish indicated, and with not less than the strength and durability properties of alloy and temper designated below for each aluminum form required.
- B. Extruded Structural Pipe and Round Tubing: ASTM B 429/B 429M, Alloy 6063-T6.
- C. Yield strength for Alloy 6063-T832 is 35 to 36 ksi (240 to 250 MPa).
- D. Drawn Seamless Tubing: ASTM B 210 (ASTM B 210M), Alloy 6063-T832.



## PIPE RAILINGS

- E. Yield strength for Alloy 6061-T6 is 32 to 35 ksi (220 to 240 MPa). Note that 6061-T6 is not suitable for bending, is somewhat less corrosion resistant than 6063, and does not anodize as well as 6063; however, 6063 is not available in plate and sheet form.
- F. Plate and Sheet: ASTM B 209 (ASTM B 209M), Alloy 6061-T6.
- G. Die and Hand Forgings: ASTM B 247 (ASTM B 247M), Alloy 6061-T6.
- H. Castings: ASTM B 26/B 26M, Alloy A356.0-T6.

### 2.5 FASTENERS

- A. General: Provide the following:
  - 1. Aluminum Railings: Type 304 stainless-steel fasteners.
- B. Post-Installed Anchors: Torque-controlled expansion anchors capable of sustaining, without failure, a load equal to 6 times the load imposed when installed in unit masonry and 4 times the load imposed when installed in concrete, as determined by testing according to ASTM E 488/E 488M, conducted by a qualified independent testing agency.

### 2.6 MISCELLANEOUS MATERIALS

- A. Welding Rods and Bare Electrodes: Select according to AWS specifications for metal alloy welded.
- B. Nonshrink, Nonmetallic Grout: Factory-packaged, nonstaining, noncorrosive, nongaseous grout complying with ASTM C 1107/C 1107M. Provide grout specifically recommended by manufacturer for interior and exterior applications.

### 2.7 FABRICATION

- A. Cut, drill, and punch metals cleanly and accurately. Remove burrs and ease edges to a radius of approximately 1/32 inch (1 mm) unless otherwise indicated. Remove sharp or rough areas on exposed surfaces.
- B. Form work true to line and level with accurate angles and surfaces.
- C. Welded Connections: Cope components at connections to provide close fit, or use fittings designed for this purpose. Weld all around at connections, including at fittings.
  - 1. Use materials and methods that minimize distortion and develop strength and corrosion resistance of base metals.
  - 2. Obtain fusion without undercut or overlap.
  - 3. Remove flux immediately.

## PIPE RAILINGS

4. At exposed connections, finish exposed surfaces smooth and blended so no roughness shows after finishing and welded surface matches contours of adjoining surfaces.
- D. Welded Connections for Aluminum Pipe: Fabricate railings to interconnect members with concealed internal welds that eliminate surface grinding, using manufacturer's standard system of sleeve and socket fittings.
- E. Nonwelded Connections: Connect members with concealed mechanical fasteners and fittings. Fabricate members and fittings to produce flush, smooth, rigid, hairline joints.
- F. Form changes in direction by bending
- G. For changes in direction made by bending, use jigs to produce uniform curvature for each repetitive configuration required. Maintain cross section of member throughout entire bend without buckling, twisting, cracking, or otherwise deforming exposed surfaces of components.
- H. Close exposed ends of railing members with prefabricated end fittings.
- I. Provide wall returns at ends of wall-mounted handrails unless otherwise indicated.
- J. Brackets, Flanges, Fittings, and Anchors: Provide wall brackets, flanges, miscellaneous fittings, and anchors to interconnect railing members to other work unless otherwise indicated.
  1. At brackets and fittings fastened to plaster or gypsum board partitions, provide crush-resistant fillers or other means to transfer loads through wall finishes to structural supports and prevent bracket or fitting rotation and crushing of substrate.

## 2.8 ALUMINUM FINISHES

- A. Appearance of Finished Work: Variations in appearance of abutting or adjacent pieces are acceptable if they are within one-half of the range of approved Samples. Noticeable variations in the same piece are unacceptable. Variations in appearance of other components are acceptable if they are within the range of approved Samples and are assembled or installed to minimize contrast.
- B. Mill Finish: AA-M12, nonspecular as fabricated.

## **PART 3 EXECUTION**

### 3.1 INSTALLATION, GENERAL

- A. Set railings accurately in location, alignment, and elevation; measured from established lines and levels and free of rack.

## PIPE RAILINGS

1. Do not weld, cut, or abrade surfaces of railing components that are coated or finished after fabrication and that are intended for field connection by mechanical or other means without further cutting or fitting.
  2. Set posts plumb within a tolerance of 1/16 inch in 3 feet (2 mm in 1 m).
  3. Align rails so variations from level for horizontal members and variations from parallel with rake of steps and ramps for sloping members do not exceed 1/4 inch in 12 feet (6 mm in 3.5 m).
- B. Control of Corrosion: Prevent galvanic action and other forms of corrosion by insulating metals and other materials from direct contact with incompatible materials.
1. Coat, with a heavy coat of bituminous paint, concealed surfaces of aluminum that are in contact with grout, concrete, masonry, wood, or dissimilar metals.

### 3.2 ANCHORING POSTS

- A. Use metal sleeves preset and anchored into concrete for installing posts. After posts are inserted into sleeves, fill annular space between post and sleeve with nonshrink, nonmetallic grout or anchoring cement, mixed and placed to comply with anchoring material manufacturer's written instructions.
- B. Anchor posts to metal surfaces with oval flanges, angle type, or floor type as required by conditions, connected to posts and to metal supporting members.

### 3.3 ATTACHING RAILINGS

- A. Attach railings to wall with wall brackets. Locate brackets as indicated or, if not indicated, at spacing required to support structural loads.
- B. Secure wall brackets and railing end flanges to building construction as follows:
1. For concrete and solid masonry anchorage, use drilled-in expansion shields and hanger or lag bolts.
  2. For hollow masonry anchorage, use toggle bolts.

### 3.4 ADJUSTING AND CLEANING

- A. Touchup Painting: Immediately after erection, clean field welds, bolted connections, and abraded areas of shop paint, and paint exposed areas with the same material as used for shop painting to comply with SSPC-PA 1 requirements for touching up shop-painted surfaces.

END OF SECTION

**PIPE RAILINGS**

**THIS PAGE LEFT BLANK INTENTIONALLY**

**SECTION 05 53 00  
METAL GRATINGS**

**PART 1      GENERAL**

1.1      SUMMARY

- A.      Section Includes:
  - 1.      Metal bar gratings.
  - 2.      Expanded-metal gratings.
  - 3.      Extruded-aluminum plank gratings.
  - 4.      Glass-fiber-reinforced plastic gratings.
  
- B.      Related Sections:
  - 1.      Section 055100 "Metal Stairs" for grating treads and landings of steel-framed stairs.
  - 2.      Section 055213 "Pipe and Tube Railings" for metal pipe and tube handrails and railings.
  - 3.      Drawings and general provisions of the Contract, including General and Supplementary Conditions and Division 01 Specification Sections, apply to this Section.

1.2      QUALITY ASSURANCE

- A.      Metal Bar Grating Standards: Comply with NAAMM MBG 531, "Metal Bar Grating Manual and NAAMM MBG 532, "Heavy-Duty Metal Bar Grating Manual."
  
- B.      Retain "Welding Qualifications" paragraph(s) below if shop or field welding is required. If retaining, also retain "Welding certificates" Paragraph in "Informational Submittals" Article.
  
- C.      Welding Qualifications: Qualify procedures and personnel according to AWS D1.1/D1.1M, "Structural Welding Code - Steel."
  
- D.      Welding Qualifications: Qualify procedures and personnel according to the following:
  - 1.      AWS D1.1/D1.1M, "Structural Welding Code - Steel."
  - 2.      AWS D1.2/D1.2M, "Structural Welding Code - Aluminum."
  - 3.      AWS D1.3, "Structural Welding Code - Sheet Steel."
  - 4.      AWS D1.6, "Structural Welding Code - Stainless Steel."

1.3      SUBMITTALS

- A.      Product Data: For the following:
  - 1.      Extruded-aluminum plank gratings.
  - 2.      Glass-fiber-reinforced plastic gratings.
  - 3.      Clips and anchorage devices for gratings.
  - 4.      Paint products.

## METAL GRATINGS

- B. Shop Drawings: Include plans, sections, details, and attachments to other work.
- C. Delegated-Design Submittal: For installed products indicated to comply with performance requirements and design criteria, including analysis data signed and sealed by the qualified professional ENGINEER responsible for their preparation.

### 1.4 PERFORMANCE REQUIREMENTS

- A. Delegated Design: Design gratings, including comprehensive engineering analysis by a qualified professional ENGINEER, using performance requirements and design criteria indicated.
- B. Structural Performance: Gratings shall withstand the effects of gravity loads and the following loads and stresses within limits and under conditions indicated.
  - 1. Floors: Uniform load of 125 lbf/sq. ft. (6.00 kN/sq. m) or concentrated load of 2000 lbf (8.90 kN), whichever produces the greater stress.
  - 2. Floors: Uniform load of 250 lbf/sq. ft. (11.97 kN/sq. m) or concentrated load of 3000 lbf (13.40 kN), whichever produces the greater stress.
  - 3. Walkways and Elevated Platforms Other Than Exits: Uniform load of 60 lbf/sq. ft. (2.87 kN/sq. m).
  - 4. Walkways and Elevated Platforms Used as Exits: Uniform load of 100 lbf/sq. ft. (4.79 kN/sq. m).
  - 5. Sidewalks and Vehicular Driveways, Subject to Trucking: Uniform load of 250 lbf/sq. ft. (11.97 kN/sq. m) or concentrated load of 8000 lbf (35.60 kN), whichever produces the greater stress.
  - 6. Limit deflection to  $L/360$  or 1/4 inch (6.4 mm), whichever is less.
- C. Seismic Performance: Provide gratings capable of withstanding the effects of earthquake motions determined according to ASCE/SEI 7.

### 1.7 PROJECT CONDITIONS

- A. Field Measurements: Verify actual locations of walls and other construction contiguous with gratings by field measurements before fabrication.

### 1.8 COORDINATION

- A. Coordinate selection of shop primers with topcoats to be applied over them. Comply with paint and coating manufacturers' written recommendations to ensure that shop primers and topcoats are compatible with one another.
- B. Coordinate installation of anchorages for gratings, grating frames, and supports. Furnish setting drawings, templates, and directions for installing anchorages, including sleeves, concrete inserts, anchor bolts, and items with integral anchors, that are to be embedded in concrete or masonry. Deliver such items to Project site in time for installation.

**PART 2      PRODUCTS**

**2.1      FERROUS METALS**

- A.      Steel Plates, Shapes, and Bars: ASTM A 36/A 36M.
- B.      Steel Bars for Bar Gratings: ASTM A 36/A 36M or steel strip, ASTM A 1011/A 1011M or ASTM A 1018/A 1018M.
- C.      Wire Rod for Bar Grating Crossbars: ASTM A 510 (ASTM A 510M).
- D.      Uncoated Steel Sheet: ASTM A 1011/A 1011M, structural steel, Grade 30 (Grade 205).
- E.      Galvanized-Steel Sheet: ASTM A 653/A 653M, structural quality, Grade 33 (Grade 230), with G90 (Z275) coating.
- F.      Type 316 stainless steel is more corrosion resistant and more expensive than Type 304.
- G.      Stainless-Steel Sheet, Strip, Plate, and Flat Bars: ASTM A 666, Type 304.
- H.      Stainless-Steel Bars and Shapes: ASTM A 276, Type 304.
- I.      Expanded-Metal Stainless Steel: ASTM F 1267, Class 3, made from stainless-steel sheet, ASTM A 666, Type 304.

**2.2      ALUMINUM**

- A.      Aluminum, General: Provide alloy and temper recommended by aluminum producer for type of use indicated, and with not less than the strength and durability properties of alloy and temper designated below for each aluminum form required.
- B.      Extruded Bars and Shapes: ASTM B 221 (ASTM B 221M), alloys as follows:
  - 1.      6061-T6 or 6063-T6, for bearing bars of gratings and shapes.
  - 2.      6061-T1, for grating crossbars.

**2.3      FASTENERS**

- A.      General: Unless otherwise indicated, provide Type 304 stainless-steel fasteners for exterior use and zinc-plated fasteners with coating complying with ASTM B 633 or ASTM F 1941 (ASTM F 1941M), Class Fe/Zn 5, at exterior walls. Select fasteners for type, grade, and class required.
  - 1.      Provide stainless-steel fasteners for fastening aluminum.
  - 2.      Provide stainless steel fasteners for fastening stainless steel.

## METAL GRATINGS

- B. Steel Bolts and Nuts: Regular hexagon-head bolts, ASTM A 307, Grade A (ASTM F 568M, Property Class 4.6); with hex nuts, ASTM A 563 (ASTM A 563M); and, where indicated, flat washers.
- C. Stainless-Steel Bolts and Nuts: Regular hexagon-head annealed stainless-steel bolts, nuts, and, where indicated, flat washers; ASTM F 593 (ASTM F 738M) for bolts and ASTM F 594 (ASTM F 836M) for nuts, Alloy Group (1) A1.
- D. Anchor Bolts: ASTM F 1554, Grade 36, of dimensions indicated; with nuts, ASTM A 563 (ASTM A 563M); and, where indicated, flat washers.
  - 1. Hot-dip galvanize or provide mechanically deposited, zinc coating where item being fastened is indicated to be galvanized.
- E. Plain Washers: Round, ASME B18.22.1 (ASME B18.22M).
- F. Lock Washers: Helical, spring type, ASME B18.21.1 (ASME B18.21.2M).
- G. Post-Installed Anchors: Torque-controlled expansion anchors or chemical anchors capable of sustaining, without failure, a load equal to six times the load imposed when installed in unit masonry and four times the load imposed when installed in concrete, as determined by testing according to ASTM E 488, conducted by a qualified independent testing agency.
  - 1. Material for Interior Locations: Carbon-steel components zinc plated to comply with ASTM B 633 or ASTM F 1941 (ASTM F 1941M), Class Fe/Zn 5, unless otherwise indicated.
  - 2. Material for Exterior Locations and Where Stainless Steel is Indicated: Alloy Group (1) A1 stainless-steel bolts, ASTM F 593 (ASTM F 738M), and nuts, ASTM F 594 (ASTM F 836M).

### 2.4 MISCELLANEOUS MATERIALS

- A. Welding Rods and Bare Electrodes: Select according to AWS specifications for metal alloy that is welded.
- B. Galvanizing Repair Paint: High-zinc-dust-content paint complying with SSPC-Paint 20 and compatible with paints specified to be used over it.
- C. Bituminous Paint: Cold-applied asphalt emulsion complying with ASTM D 1187.

### 2.5 FABRICATION

- A. Shop Assembly: Fabricate grating sections in shop to greatest extent possible to minimize field splicing and assembly. Disassemble units only as necessary for shipping and handling limitations. Use connections that maintain structural value of joined pieces. Clearly mark units for reassembly and coordinated installation.
- B. Cut, drill, and punch material cleanly and accurately. Remove burrs and ease



## METAL GRATINGS

edges to a radius of approximately 1/32 inch (1 mm) unless otherwise indicated. Remove sharp or rough areas on exposed surfaces.

- C. Form from materials of size, thickness, and shapes indicated, but not less than that needed to support indicated loads.
- D. Fit exposed connections accurately together to form hairline joints.
- E. Welding: Comply with AWS recommendations and the following:
  - 1. Use materials and methods that minimize distortion and develop strength and corrosion resistance of base metals.
  - 2. Obtain fusion without undercut or overlap.
  - 3. Remove welding flux immediately.
- F. Provide for anchorage of type indicated; coordinate with supporting structure. Fabricate and space the anchoring devices to secure gratings, frames, and supports rigidly in place and to support indicated loads.
  - 1. Fabricate toeplates to fit grating units and weld to units in shop unless otherwise indicated.
  - 2. Fabricate toeplates for attaching in the field.
  - 3. Toeplate Height: 4 inches (100 mm) unless otherwise indicated.

### 2.6 METAL BAR GRATINGS

- A. Manufacturers: Subject to compliance with requirements, available manufacturers offering products that may be incorporated into the Work include, but are not limited to, the following:
  - 1. All American Grating.
  - 2. Fisher & Ludlow; a NUCOR Company.
  - 3. Ohio Gratings, Inc.
- B. Welded Steel Grating:
  - 1. Bearing Bar Spacing: 7/16 or 1/2 inch (11 or 13 mm) o.c.
  - 2. Bearing Bar Depth: As required to comply with structural performance requirements.
  - 3. Bearing Bar Thickness: As required to comply with structural performance requirements.
  - 4. Crossbar Spacing: 4 inches (102 mm) o.c.
  - 5. Traffic Surface: Serrated.
  - 6. Steel Finish: Hot-dip galvanized with a coating weight of not less than 1.8 oz./sq. ft. (550 g/sq. m) of coated surface.
- C. Pressure-Locked Steel Grating: Fabricated by pressing rectangular flush-top crossbars into slotted bearing bars or swaging crossbars between bearing bars.
  - 1. Bearing Bar Spacing: 7/16 or 1/2 inch (11 or 13 mm) o.c.
  - 2. Bearing Bar Depth: As required to comply with structural performance requirements.
  - 3. Bearing Bar Thickness: As required to comply with structural perfor-

## METAL GRATINGS

- mance requirements.
4. Crossbar Spacing: 4 inches (102 mm) o.c.
  5. Traffic Surface: Serrated.
  6. Steel Finish: Hot-dip galvanized with a coating weight of not less than 1.8 oz./sq. ft. (550 g/sq. m) of coated surface.
- D. Pressure-Locked, Stainless-Steel Grating: Fabricated by pressing rectangular flush-top crossbars into slotted bearing bars or swaging crossbars between bearing bars.
1. Bearing Bar Spacing: 7/16 or 1/2 inch (11 or 13 mm) o.c.
  2. Bearing Bar Depth: As required to comply with structural performance requirements.
  3. Bearing Bar Thickness: As required to comply with structural performance requirements.
  4. Crossbar Spacing: 4 inches (102 mm) o.c.
  5. Traffic Surface: Serrated.
  6. Finish: Abrasive blasted.
- E. Pressure-Locked, Rectangular Bar Aluminum Grating: Fabricated by pressing rectangular flush-top crossbars into slotted bearing bars or swaging crossbars between bearing bars.
1. Bearing Bar Spacing: 7/16 or 1/2 inch (11 or 13 mm) o.c.
  2. Bearing Bar Depth: As required to comply with structural performance requirements.
  3. Bearing Bar Thickness: As required to comply with structural performance requirements.
  4. Crossbar Spacing: 4 inches (102 mm) o.c.
  5. Traffic Surface: Applied abrasive finish consisting of aluminum-oxide aggregate in an epoxy-resin adhesive.
  6. Aluminum Finish: Mill finish.
- F. Pressure-Locked, Aluminum I-Bar Grating: Fabricated by swaging crossbars between bearing bars.
1. Bearing Bar Spacing: 7/16 or 1/2 inch (11 or 13 mm) o.c.
  2. Bearing Bar Depth: As required to comply with structural performance requirements.
  3. Bearing Bar Flange Width: 1/4 inch (6.4 mm).
  4. Crossbar Spacing: 4 inches (102 mm) o.c.
  5. Traffic Surface: Grooved.
  6. Aluminum Finish: Mill finish.
- G. Removable Grating Sections: Fabricate with banding bars attached by welding to entire perimeter of each section. Include anchors and fasteners of type indicated or, if not indicated, as recommended by manufacturer for attaching to supports.
1. Provide no fewer than four weld lugs for each heavy-duty grating section, with each lug shop welded to two bearing bars.
  2. Provide no fewer than four flange blocks for each section of aluminum I-bar grating, with block designed to fit over lower flange of I-shaped bearing bars.

## METAL GRATINGS

3. Furnish threaded bolts with nuts and washers for securing grating to supports.
- H. Fabricate cutouts in grating sections for penetrations indicated. Arrange cutouts to permit grating removal without disturbing items penetrating gratings.
- I. Do not notch bearing bars at supports to maintain elevation.

### 2.7 EXPANDED-METAL GRATINGS

- A. Provide expanded-metal gratings in material, finish, style, size, thickness, weight, and type indicated or, if not indicated, as recommended by manufacturer for indicated applications and as needed to support indicated loads.
  1. Material: Stainless steel.
  2. Stainless-Steel Finish: Mill finish, as fabricated.
  3. Style Designation: 1-1/2 number 9.
  4. Type: I, expanded.
- B. Fabricate cutouts in grating sections for penetrations of sizes and at locations indicated. Cut openings neatly and accurately to size. Edge-band openings with bars having a thickness not less than overall grating thickness at contact points.
- C. Where gratings are pierced by pipes, ducts, and structural members, cut openings neatly and accurately to size and weld a strap collar not less than 1/8 inch (3 mm) thick to the cut ends. Divide panels into sections only to extent required for installation where grating platforms and runways are to be placed around previously installed pipe, ducts, and structural members.

### 2.8 EXTRUDED-ALUMINUM PLANK GRATINGS

- A. Provide extruded-aluminum plank gratings in type, size, and finish indicated or, if not indicated, as recommended by manufacturer for indicated applications and as needed to support indicated loads.
  1. Type: Extruded-aluminum planks approximately 6 inches (152 mm) wide with multiple flanges approximately 1.2 inches (30 mm) o.c., acting as bearing bars connected by a web that serves as a walking surface. Top surface has raised ribs to increase slip resistance.
  2. Depth: As required to comply with structural performance requirements.
  3. Perforations: Rectangular, 19/32 by 3 inches (15 by 76 mm), with adjacent rows staggered.
  4. Finish: Mill finish, as fabricated.
- B. Fabricate cutouts in grating sections for penetrations indicated. Arrange cutouts to permit grating removal without disturbing items penetrating gratings.

### 2.9 GLASS-FIBER-REINFORCED PLASTIC GRATINGS

- A. Molded Glass-Fiber-Reinforced Gratings: Bar gratings made by placing glass-

## **METAL GRATINGS**

fiber strands that have been saturated with thermosetting plastic resin in molds in alternating directions to form interlocking bars without voids and with a high resin content.

1. Configuration: As required to comply with structural performance requirements.
  2. Resin: Polyester.
  3. Color: Yellow.
  4. Traffic Surface: Applied abrasive finish.
- B. Fabricate cutouts in grating sections for penetrations indicated. Arrange cutouts to permit grating removal without disturbing items penetrating gratings.

### **2.10 ALUMINUM FINISHES**

- A. Finish designations prefixed by AA comply with the system established by the Aluminum Association for designating aluminum finishes.

### **2.11 STEEL FINISHES**

- A. Comply with NAAMM's "Metal Finishes Manual for Architectural and Metal Products" for recommendations for applying and designating finishes.
- B. Finish gratings, frames, and supports after assembly.
- C. Galvanizing: Hot-dip galvanize items as indicated to comply with ASTM A 153/A 153M for steel and iron hardware and with ASTM A 123/A 123M for other steel and iron products.
1. Do not quench or apply post galvanizing treatments that might interfere with paint adhesion.

## **PART 3      EXECUTION**

### **3.1 INSTALLATION, GENERAL**

- A. Fastening to In-Place Construction: Provide anchorage devices and fasteners where necessary for securing gratings to in-place construction. Include threaded fasteners for concrete and masonry inserts, through-bolts, lag bolts, and other connectors.
- B. Cutting, Fitting, and Placement: Perform cutting, drilling, and fitting required for installing gratings. Set units accurately in location, alignment, and elevation; measured from established lines and levels and free of rack.
- C. Provide temporary bracing or anchors in formwork for items that are to be built into concrete or masonry.
- D. Fit exposed connections accurately together to form hairline joints.

## METAL GRATINGS

1. Weld connections that are not to be left as exposed joints but cannot be shop welded because of shipping size limitations. Do not weld, cut, or abrade the surfaces of exterior units that have been hot-dip galvanized after fabrication and are for bolted or screwed field connections.
- E. Attach toeplates to gratings by welding at locations indicated.
- F. Field Welding: Comply with the following requirements:
  1. Use materials and methods that minimize distortion and develop strength and corrosion resistance of base metals.
  2. Obtain fusion without undercut or overlap.
  3. Remove welding flux immediately.
- G. Corrosion Protection: Coat concealed surfaces of aluminum that will come into contact with grout, concrete, masonry, wood, or dissimilar metals, with a heavy coat of bituminous paint.

### 3.2 INSTALLING METAL BAR GRATINGS

- A. General: Install gratings to comply with recommendations of referenced metal bar grating standards that apply to grating types and bar sizes indicated, including installation clearances and standard anchoring details.
- B. Attach removable units to supporting members with type and size of clips and fasteners indicated or, if not indicated, as recommended by grating manufacturer for type of installation conditions shown.
- C. Attach nonremovable units to supporting members by welding where both materials are same; otherwise, fasten by bolting as indicated above.

### 3.3 INSTALLING EXPANDED-METAL GRATINGS

- A. General: Comply with manufacturer's written instructions for installing gratings.
- B. Place units with straight edge of bond up and with long direction of diamond-shaped openings parallel to direction of span.
- C. Attach removable units to supporting members by bolting at 6-inch (150-mm) intervals.
- D. Attach nonremovable units to supporting members by welding unless otherwise indicated. Space welds at 6-inch (150-mm) intervals.
- E. Attach aluminum units to steel supporting members by bolting at 6-inch (150-mm) intervals.
- F. Butt edges parallel to long direction of diamond-shaped openings and weld at

## **METAL GRATINGS**

every second bond point. Place individual grating sections so diamonds of one piece are aligned with those of adjacent sections.

### **3.4 INSTALLING GLASS-FIBER-REINFORCED PLASTIC GRATINGS**

- A. Comply with manufacturer's written instructions for installing gratings. Use manufacturer's standard stainless-steel anchor clips and hold-down devices for bolted connections.

END OF SECTION

**DIVISION 06**

**WOOD, PLASTICS, AND COMPOSITES**

**THIS PAGE LEFT BLANK INTENTIONALLY**



**SECTION 06 10 53**  
**MISCELLANEOUS ROUGH CARPENTRY**

**PART 1 - GENERAL**

1.1 SUMMARY

- A. Section Includes:
1. Rooftop equipment bases and support curbs.
  2. Wood blocking, cants, and nailers.
  3. Plywood backing panels.
  4. Wood framed stud walls.

1.2 ACTION SUBMITTALS

- A. Product Data: For each type of process and factory-fabricated product.

1.3 INFORMATIONAL SUBMITTALS

- A. Evaluation Reports: For the following, from ICC-ES:
1. Preservative-treated wood.

**PART 2 - PRODUCTS**

2.1 WOOD PRODUCTS, GENERAL

- A. Lumber: DOC PS 20 and applicable rules of grading agencies indicated. If no grading agency is indicated, provide lumber that complies with the applicable rules of any rules-writing agency certified by the ALSC Board of Review. Provide lumber graded by an agency certified by the ALSC Board of Review to inspect and grade lumber under the rules indicated.
1. Factory mark each piece of lumber with grade stamp of grading agency.
  2. For exposed lumber indicated to receive a stained or natural finish, mark grade stamp on end or back of each piece
  3. Dress lumber, S4S, unless otherwise indicated.

2.2 WOOD-PRESERVATIVE-TREATED MATERIALS

- A. Preservative Treatment by Pressure Process: AWPA U1; Use Category UC2 for interior construction not in contact with ground
1. Preservative Chemicals: Acceptable to authorities having jurisdiction and containing no arsenic or chromium.

## MISCELLANEOUS ROUGH CARPENTRY

- B. Kiln-dry lumber after treatment to a maximum moisture content of 19 percent. Do not use material that is warped or does not comply with requirements for untreated material.
- C. Mark lumber with treatment quality mark of an inspection agency approved by the ALSC Board of Review.
- D. Application: Treat all miscellaneous carpentry unless otherwise indicated.
  - 1. Wood cants, nailers, curbs, equipment support bases, blocking, stripping, and similar members in connection with roofing, flashing, vapor barriers, and waterproofing.
  - 2. Wood sills, sleepers, blocking, furring, stripping, and similar concealed members in contact with masonry or concrete.
  - 3. Wood framing and furring attached directly to the interior of below-grade exterior masonry or concrete walls.
  - 4. Wood framing members that are less than 18 inches (460 mm) above the ground in crawlspaces or unexcavated areas.
  - 5. Wood floor plates that are installed over concrete slabs-on-grade.

### 2.3 PLYWOOD BACKING PANELS

- A. Equipment Backing Panels: Plywood, DOC PS 1, Exterior, A-C in thickness indicated or, if not indicated, not less than 3/4-inch nominal thickness.

### 2.4 FASTENERS

- A. General: Provide fasteners of size and type indicated that comply with requirements specified in this article for material and manufacture.
  - 1. Where carpentry is exposed to weather, in ground contact, pressure-preservative treated, or in area of high relative humidity, provide fasteners of Type 304 stainless steel.
- B. Power-Driven Fasteners: Fastener systems with an evaluation report acceptable to authorities having jurisdiction, based on ICC-ES AC70.

## PART 3 - EXECUTION

### 3.1 INSTALLATION, GENERAL

- A. Framing Standard: Comply with AF&PA's WCD 1, "Details for Conventional Wood Frame Construction," unless otherwise indicated.
- B. Set carpentry to required levels and lines, with members plumb, true to line, cut, and fitted. Fit carpentry accurately to other construction. Locate nailers, blocking,

## MISCELLANEOUS ROUGH CARPENTRY

grounds, and similar supports to comply with requirements for attaching other construction.

- C. Install plywood backing panels by fastening to studs; coordinate locations with utilities requiring backing panels.
- D. Do not splice structural members between supports unless otherwise indicated.
- E. Comply with AWWPA M4 for applying field treatment to cut surfaces of preservative-treated lumber.
- F. Securely attach carpentry work to substrate by anchoring and fastening as indicated, complying with the following:
  - 1. Table 2304.9.1, "Fastening Schedule," in ICC's International Building Code.
  - 2. Table R602.3(1), "Fastener Schedule for Structural Members," and Table R602.3(2), "Alternate Attachments," in ICC's International Residential Code for One- and Two-Family Dwellings.
  - 3. ICC-ES evaluation report for fastener.

### 3.2 PROTECTION

- A. Protect wood that has been treated with inorganic boron (SBX) from weather. If, despite protection, inorganic boron-treated wood becomes wet, apply EPA-registered borate treatment. Apply borate solution by spraying to comply with EPA-registered label.

END OF SECTION

**MISCELLANEOUS ROUGH CARPENTRY**

THIS PAGE INTENTIONALLY LEFT BLANK

**SECTION 06 6000  
PLASTIC FABRICATIONS**

**PART 1 - GENERAL**

**1.1 SUMMARY**

- A. This Section includes fiberglass reinforced plastic, handrails, pultruded gratings, stairs, and flat sheets complete with anchorage, inserts and hangers.

**1.2 QUALITY ASSURANCE**

- A. Shop Assembly: Preassemble items in shop to greatest extent possible to minimize field splicing and assembly. Disassemble units only as necessary for shipping and handling limitations. Clearly mark units for reassembly and coordinated installation.

**1.3 DEFINITIONS**

- A. Definitions in ASTM E 985 for railing-related terms apply to this Section.

**1.4 SUBMITTALS**

- A. Submit the following in accordance with conditions of Contract and Division 1 Specification Sections:
1. Product data including manufacturer's specifications and instructions for each type of assembly and accessories.
  2. Provide assemblies which, when installed, comply with the following minimum requirements.
  3. Gratings and stairs, capable of supporting a uniformly distributed load of 200 pounds per square foot of horizontal surface.
  4. Railings per requirements listed in this Section.
  5. Shop Drawings showing layout and type of units, anchorage details, conditions requiring closure strips supplementary framing, cut openings, and other accessories.

**1.5 WARRANTY (NOT USED)**

**1.6 SYSTEM PERFORMANCE REQUIREMENTS**

- A. Structural Performance of Handrails and Railing Systems: Engineer, fabricate, and install handrails and railing systems to withstand the following structural loads without exceeding the allowable design working stress of the materials for handrails, railing systems, anchors, and connections. Apply each load to produce the maximum stress in each of the respective components comprising handrails and railing systems.
- B. Top Rail of Guardrail Systems: Capable of withstanding the following loads applied as indicated:
1. Concentrated load of 200 pounds applied at any point and in any direction.
  2. Uniform load of 50 pounds per linear feet applied horizontally and concurrently with uniform load of 50 pounds per linear feet applied vertically downward.
  3. Concentrated load need not be assumed to act concurrently with uniform loads.
- C. Handrails Not Serving as Top Rails: Capable of withstanding the following loads applied as indicated:

## PLASTIC FABRICATIONS

1. Concentrated load of 200 pounds applied at any point and in any direction
  2. Uniform load of 50 pounds per linear feet applied in any direction.
  3. Concentrated and uniform loads need not be assumed to act concurrently.
- D. Infill Area of Guardrail Systems: Capable of withstanding a horizontal concentrated load of 200 pounds applied to one (1) square feet at any point in the system including panels, intermediate rails, balusters, or other elements composing the infill area.
1. Above load need not be assumed to act concurrently with loads on top rails of railing systems in determining stress on guard.
- E. Structural support members shall not deflect more than  $L/180$  of span for structural members unless specifically stated otherwise in drawings and/or supplementary conditions. Connections shall be designed to transfer the design loads.
- F. Gratings: Design live loads of FRP gratings for walkway applications shall be 100 psf (2.87 kN/m<sup>2</sup>) uniformly distributed load per ASCE 7 or as required by the governing building code with a maximum deflection of 0.25" (6.4mm) at the center of a simple span.
- G. Stair Treads: Stair treads shall be designed for a uniform load of 100 psf (4.79 kN/m<sup>2</sup>) per ASCE 7 or a concentrated load of 300 lbs (1.33 kN) on an area of four (4) sq. inches (2580.6 mm<sup>2</sup>) located in the center of the tread, whichever produces greater stress and deflect less than 0.25" (6.4 mm). The two loads do not act concurrently.
- H. Thermal Movements: Allow for thermal movement resulting from the following maximum change (range) in ambient temperature in the design, fabrication, and installation of handrails and railings to prevent buckling, opening up of joints, overstressing of components, connections and other detrimental effects. Base design calculation on actual surface temperatures of materials due to both solar heat gain and nighttime sky heat loss.
1. Temperature Change (Range): 120 deg F (67 deg C), ambient; 180 deg F (100 deg C), material surfaces.

## PART 2 - PRODUCTS

### 2.1 MANUFACTURERS

- A. Available Manufacturers: Subject to compliance with requirements, manufacturers offering products which may be incorporated in the work include, but are not limited to, the following:
1. Strongwell Corp.
  2. Molded Fiberglass Co.
  3. Gator-Grate.
  4. International Grating.
  5. Fibergrate.
  6. Structural Fiberglass Inc.
  7. Or ENGINEER approved equal.

### 2.2 MATERIALS

- A. Pultruded Fiberglass Grating: Non-corrosive pultruded construction so that bearing bars are interwoven with the reinforcing glass of the cross bars. Resin to be vinyl ester. All cut and sanded surfaces shall be coated with surfacing resin. Color shall be grey.

## PLASTIC FABRICATIONS

- B. Glass-Fiber-Reinforced Plastic Gratings: Molded Glass-Fiber-Reinforced Gratings: Where Molded Bar Gratings are called for on the plans - made by placing glass-fiber strands that have been saturated with thermosetting plastic resin in molds in alternating directions to form interlocking bars without voids and with a high resin content.
  - 1. Configuration: As required to comply with structural performance requirements.
  - 2. Resin: Vinyl Ester.
  - 3. Color: Grey.
  - 4. Traffic Surface: Applied abrasive finish.
- C. Fasteners: Use 316L stainless steel brackets clips and bolts for type of loading and installation condition shown. Use toothed lead, stainless steel expansion bolt devices for drilled-in-place anchors. Furnish inserts, as required, to be set into concrete or masonry work.

### 2.3 FABRICATION

- A. All structural shapes are to be manufactured by the pultrusion process with a glass content minimum of 45 percent, maximum of 55 percent by weight. The structural shapes shall be composed of fiberglass reinforcement and resin in qualities, quantities, properties, arrangements and dimensions as necessary to meet the design requirements and dimensions as specified in the Contract Documents. Resin to be vinyl ester.
- B. The bearing bars shall be joined into panels by passing continuous length fiberglass pultruded cross rods through the web of each bearing bar. A continuous fiberglass pultruded bar shaped section shall be wedged between the two (2) cross rod spacers mechanically locking the notches in the cross rod spacers to the web of the bearing bars. Continuous adhesive bonding shall be achieved between the cross rod spacers and the bearing web and between the bar shaped wedge and the two (2) cross rod spacers locking the entire panel together to give a panel that resists twist and prevents internal movement of the bearing bars. Each stair tread shall utilize a box-shaped nosing on its lead edge to enclose cross rods and ensure a smooth vertical edge.
- C. General: Fabricate handrails, guardrails, kickplates and railing systems to dimensions and details shown on plans and conforming to OSHA requirements. Provide members in sizes and profiles indicated, with supporting posts and brackets of size and spacing shown, but not less than required to support the design loadings indicated. Fabricate members and fittings to produce, smooth, rigid, hairline joints.
- D. Kickplate: Where indicated, provide kickplates at railings around openings and at edge of open-sided floors and platforms. Fabricate to dimensions and details shown, or if not shown, use manufacturer's standard section, if available, to provide kickplates four (4) inches high.
- E. Brackets, Flanges, Fittings, and Anchors: Provide manufacturer's standard wall brackets, flanges, miscellaneous fittings and anchors for interconnection of grating, stairs, handrail, and railing members to other work, unless otherwise indicated.
- F. Provide non-skid abrasive surface on treads, landings, stairs, catwalks, platforms, ramps, and hatch covers in FRP anti-slip grating, of angular silica particles embedded in the upper portion of the grating or plates as required. On stairs, alternate colors of yellow and gray for treads and landings, commencing with the first tread or landing in the plane of the operating floor being yellow.

## PLASTIC FABRICATIONS

- G. Fiberglass reinforcement shall be a combination of continuous roving, continuous strand mat, and surfacing veil in sufficient quantities as needed by the application and/or physical properties required.
- H. All finished surfaces of FRP items and fabrications shall be smooth, resin-rich, free of voids and without dry spots, cracks, crazes or unreinforced areas. All glass fibers shall be well covered with resin to protect against their exposure due to wear or weathering.
- I. Preassemble railing systems in shop to greatest extent possible to minimize field splicing and assembly. Disassemble units only as necessary for shipping and handling limitations. Clearly mark units for reassembly and coordinated installation. Use connections that maintain structural value of joined pieces. Clearly mark units for reassembly and coordinated installation.
- J. Connections: Fabricate railing systems and handrails for connection of members by means of railing manufacturer's standard concealed fasteners and fittings unless otherwise indicated. Fabricate members and fittings to produce flush, smooth, rigid, hairline joints.
- K. Fabricate splice joints for field connection using structural adhesive where this represents manufacturer's standard splicing method.
- L. Provide inserts and other anchorage devices for connecting handrails and railing systems to concrete or masonry work. Fabricate anchorage devices capable of withstanding loadings imposed by handrails and railing systems. Coordinate anchorage devices with supporting structure.
- M. For railing posts set in concrete, provide preset sleeves of steel, not less than six (6) inches long and inside dimensions not less than 1/2 inch greater than outside dimensions of post, with steel plate forming bottom closure.
- N. For removable railing posts, fabricate slip fit sockets from FRP structural elements sized for a close fit with posts and to limit deflection of post without lateral load, measured at top, to not more than 1/12 of post height. Provide socket covers designed and fabricated to resist accidental dislodgment.
- O. For handrails and railing systems that are exposed to exterior or to moisture from condensation or other sources, provide weepholes or other means for evacuation of entrapped water in hollow sections of railing members.
- P. FRP products exposed to weather shall contain an ultraviolet inhibitor. Should additional ultraviolet protection be required, a UV coating can be applied.
- Q. Fabricate joints that will be exposed to weather in a manner to exclude water. Provide weep holes where water may collect.
- R. Provide wall returns at ends of wall mounted handrails, unless otherwise indicated.



## **PLASTIC FABRICATIONS**

### **PART 3 - EXECUTION**

#### **3.1 PREPARATION**

- A. Coordinate setting drawings, diagrams, templates, instructions, and directions for installation of anchorages, such as sleeves, concrete inserts, anchor bolts and miscellaneous items having integral anchors, which are to be embedded in concrete as masonry construction. Coordinate delivery of such items to project site.
- B. Take field measurements prior to preparation of shop drawings and fabrication, where possible. Do not delay job progress; allow for adjustments during installation where taking field measurements before fabrication might delay work.

#### **3.2 INSTALLATION**

- A. Fit exposed connections accurately together to form tight, hairline joints.
- B. Anchor posts, grating, stairs and railings with manufacturer's standard fittings designed for this purpose. Provide removable sections as indicated.

#### **3.3 ADJUST AND CLEAN**

- A. Protect finishes of grating, stairs, posts and railings from damage during construction period by use of temporary protective coverings approved by manufacturer. Remove protective covering at project completion. Restore finishes damaged during installation and construction period so that no evidence remains of correction work. Return items, which cannot be refinished in the field, to the shop; make required alterations and refinish entire unit, or provide new units as required.

**END OF SECTION**

**PLASTIC FABRICATIONS**

**THIS PAGE LEFT BLANK INTENTIONALLY**

**SECTION 06 71 10**  
**GLASS-FIBER REINFORCED PLASTIC (FRP) STRUCTURAL SHAPES**

**Part 1 General**

**1.01 Related Documents**

This section includes fiberglass reinforced plastic, handrails, grating, stairs, and flat sheets complete with anchorage, inserts and hangers.

**1.02 Summary**

This section includes fiberglass reinforced plastic structural shapes as shown on the plans.

**1.03 Submittals**

Submit the following in accordance with conditions of Contract and Division 01 Specification Sections:

- A. The CONTRACTOR shall furnish shop drawings of all fabricated structural systems and accessories in accordance with the provisions of this Section.
- B. The CONTRACTOR shall furnish manufacturer's shop drawings clearly showing material sizes, types, styles, part or catalog numbers, complete details for the fabrication of and erection of components including, but not limited to, location, lengths, type and sizes of fasteners, clip angles, member sizes, and connection details.
- C. The CONTRACTOR shall submit the manufacturer's published literature including structural design data, structural properties data, corrosion resistance tables, certificates of compliance, test reports as applicable, and design calculations for systems not sized or designed in the Contract Documents, sealed by a Professional Engineer.
- D. The CONTRACTOR may be requested to submit sample pieces of each item specified herein for acceptance by the ENGINEER as to quality and color. Sample pieces shall be manufactured by the method to be used in the WORK.

**1.04 Quality Assurance**

Shop Assembly: Preassemble items in shop to greatest extent possible to minimize field splicing and assembly. Disassemble units only as necessary for shipping and handling limitations. Clearly mark units for reassembly and coordinated installation.

**1.05 System Performance Requirements**

- A. Structural Performance of Handrails and Railing Systems: Engineer, fabricate, and install handrails and railing systems to withstand the following structural loads without exceeding the allowable design working stress of the materials for handrails, railing systems, anchors, and connections. Apply each load to produce the maximum stress in each of the respective components comprising handrails and railing systems.
- B. Top Rail of Guardrail Systems: Capable of withstanding the following loads applied as indicated:
  - 1. Concentrated load of 200 pounds applied at any point and in any direction.

## **GLASS-FIBER REINFORCED PLASTIC (FRP) STRUCTURAL SHAPES**

2. Uniform load of 50 pounds per linear feet applied horizontally and concurrently with uniform load of 50 pounds per linear feet applied vertically downward.
  3. Concentrated load need not be assumed to act concurrently with uniform loads.
- C. Handrails Not Serving as Top Rails: Capable of withstanding the following loads applied as indicated:
1. Concentrated load of 200 pounds applied at any point and in any direction
  2. Uniform load of 50 pounds per linear feet applied in any direction.
  3. Concentrated and uniform loads need not be assumed to act concurrently.
- D. Infill Area of Guardrail Systems: Capable of withstanding a horizontal concentrated load of 200 pounds applied to one square feet at any point in the system including panels, intermediate rails, balusters, or other elements composing the infill area.
1. Above load need not be assumed to act concurrently with loads on top rails of railing systems in determining stress on guard.
- E. Structural support members shall not deflect more than  $L/180$  of span for structural members unless specifically stated otherwise in drawings and/or supplementary conditions. Connections shall be designed to transfer the design loads
- F. Thermal Movements: Allow for thermal movement resulting from the following maximum change (range) in ambient temperature in the design, fabrication, and installation of handrails and railings to prevent buckling, opening up of joints, overstressing of components, connections and other detrimental effects. Base design calculation on actual surface temperatures of materials due to both solar heat gain and nighttime sky heat loss.
1. Temperature Change (Range): 120 deg F (67 deg C), ambient; 180 deg F (100 deg C), material surfaces.

### **1.06 Product Delivery and Storage**

- A. Delivery of Materials: Manufactured materials shall be delivered in original, unbroken pallets, packages, containers, or bundles bearing the label of the manufacturer. Adhesives, resins and their catalysts and hardeners shall be crated or boxed separately and noted as such to facilitate their movement to a dry indoor storage facility.
- B. Storage of Products: All materials shall be carefully handled to prevent them from abrasion, cracking, chipping, twisting, and other types of damage. Store adhesives, resins and their catalysts and hardeners in dry indoor storage facilities between 70 and 85 degrees Fahrenheit (21 to 29 degrees Celsius) until they are required.

## **Part 2 Products**

### **2.01 Acceptable Manufacturers**

Available Manufacturers: Subject to compliance with requirements, manufacturers offering products which may be incorporated in the work include, but are not limited to, the following:

Morrison Molded Fiberglass Co.  
Gator-Grate  
International Grating  
Fibergrate

## GLASS-FIBER REINFORCED PLASTIC (FRP) STRUCTURAL SHAPES

Structural Fiberglass Inc.  
Or ENGINEER approved Equal

### 2.02 General

- A. All structural shapes are to be manufactured by the pultrusion process with a glass content minimum of 45%, maximum of 55% by weight. The structural shapes shall be composed of fiberglass reinforcement and resin in qualities, quantities, properties, arrangements and dimensions as necessary to meet the design requirements and dimensions as specified in the Contract Documents.
  - 1. The bearing bars shall be joined into panels by passing continuous length fiberglass pultruded cross rods through the web of each bearing bar. A continuous fiberglass pultruded bar shaped section shall be wedged between the two cross rod spacers mechanically locking the notches in the cross rod spacers to the web of the bearing bars. Continuous adhesive bonding shall be achieved between the cross rod spacers and the bearing web and between the bar shaped wedge and the two cross rod spacers locking the entire panel together to give a panel that resists twist and prevents internal movement of the bearing bars. Each stair tread shall utilize a box-shaped nosing on its lead edge to enclose cross rods and ensure a smooth vertical edge.
- B. Fiberglass reinforcement shall be a combination of continuous roving, continuous strand mat, and surfacing veil in sufficient quantities as needed by the application and/or physical properties required.
- C. Resins shall be ISOFR, fire retardant isophthalic polyester; or VEFR, fire retardant vinyl ester, with chemical formulation necessary to provide the corrosion resistance, strength and other physical properties as required.
- D. All finished surfaces of FRP items and fabrications shall be smooth, resin-rich, free of voids and without dry spots, cracks, crazes or unreinforced areas. All glass fibers shall be well covered with resin to protect against their exposure due to wear or weathering.

### 2.03 Fabrication

- A. General: Fabricate handrails, guardrails, kickplates and railing systems to dimensions and details shown on plans and conforming to OSHA requirements. Provide members in sizes and profiles indicated, with supporting posts and brackets of size and spacing shown, but not less than required to support the design loadings indicated. Fabricate members and fittings to produce, smooth, rigid, hairline joints.
- B. Kickplate: Where indicated, provide kickplates at railings around openings and at edge of open-sided floors and platforms. Fabricate to dimensions and details shown, or if not shown, use manufacturer's standard section, if available, to provide kickplates 4" high.
- C. Brackets, Flanges, Fittings, and Anchors: Provide manufacturer's standard wall brackets, flanges, miscellaneous fittings and anchors for interconnection of grating, stairs, handrail, and railing members to other work, unless otherwise indicated.
- D. Provide non-skid abrasive surface on treads, landings, stairs, catwalks, platforms, ramps, and hatch covers in FRP anti-slip grating, of angular silica particles embedded in the upper portion of the grating or plates as required. On stairs, alternate colors of yellow and gray for

## GLASS-FIBER REINFORCED PLASTIC (FRP) STRUCTURAL SHAPES

treads and landings, commencing with the first tread or landing in the plane of the operating floor being yellow.

- E. Preassemble railing systems in shop to greatest extent possible to minimize field splicing and assembly. Disassemble units only as necessary for shipping and handling limitations. Clearly mark units for reassembly and coordinated installation. Use connections that maintain structural value of joined pieces. Clearly mark units for reassembly and coordinated installation.
- F. Connections: Fabricate railing systems and handrails for connection of members by means of railing manufacturer's standard concealed fasteners and fittings unless otherwise indicated. Fabricate members and fittings to produce flush, smooth, rigid, hairline joints.
- G. Fabricate splice joints for field connection using structural adhesive where this represents manufacturer's standard splicing method.
- H. Provide inserts and other anchorage devices for connecting handrails and railing systems to concrete or masonry work. Fabricate anchorage devices capable of withstanding loadings imposed by handrails and railing systems. Coordinate anchorage devices with supporting structure.
- I. For railing posts set in concrete, provide preset sleeves of steel, not less than 6 inches long and inside dimensions not less than 1/2 inch greater than outside dimensions of post, with steel plate forming bottom closure.
- J. For removable railing posts, fabricate slip fit sockets from FRP structural elements sized for a close fit with posts and to limit deflection of post without lateral load, measured at top, to not more than 1/12 of post height. Provide socket covers designed and fabricated to resist accidental dislodgment.
- K. FRP products exposed to weather shall contain an ultraviolet inhibitor. Should additional ultraviolet protection be required, a UV coating can be applied.
- L. Fabricate joints that will be exposed to weather in a manner to exclude water. Provide weep holes where water may collect.
- M. Provide wall returns at ends of wall mounted handrails, unless otherwise indicated.

### Part 3 Execution

#### 3.01 Preparation

Coordinate setting drawings, diagrams, templates, instructions, and directions for installation of anchorages, such as sleeves, concrete inserts, anchor bolts and miscellaneous items having integral anchors, which are to be embedded in concrete or masonry construction. Coordinate delivery of such items to project site.

Take field measurements prior to preparation of shop drawings and fabrication, where possible. Do not delay job progress; allow for adjustments during installation where taking field measurements before fabrication might delay work.

#### 3.02 Installation

Fit exposed connections accurately together to form tight, hairline joints.

## **GLASS-FIBER REINFORCED PLASTIC (FRP) STRUCTURAL SHAPES**

Anchor structural shapes with manufacturer's standard fittings where available and designed for this purpose. Provide removable sections as indicated.

### **3.03 Adjust and Clean**

Protect finishes of structural shapes from damage during construction period by use of temporary protective coverings approved by manufacturer. Remove protective covering at project completion. Restore finishes damaged during installation and construction period so that no evidence remains of correction work. Return items, which cannot be refinished in the field, to the shop; make required alterations and refinish entire unit, or provide new units as required.

END OF SECTION

**GLASS-FIBER REINFORCED PLASTIC (FRP) STRUCTURAL SHAPES**

**THIS PAGE LEFT BLANK INTENTIONALLY**



**DIVISION 07**

**THERMAL AND MOSITURE PROTECTION**

**THIS PAGE LEFT BLANK INTENTIONALLY**

**SECTION 07 92 00  
JOINT SEALANTS**

**PART 1 - GENERAL**

1.1 SUMMARY

- A. Section Includes:
  - 1. Silicone joint sealants.
  - 2. Urethane joint sealants.
  - 3. Latex joint sealants.
  - 4. Acoustical joint sealants.

1.2 ACTION SUBMITTALS

- A. Product Data: For each joint-sealant product indicated.
- B. Samples: For each kind and color of joint sealant required.
- C. Joint-Sealant Schedule: Include the following information:
  - 1. Joint-sealant application, joint location, and designation.
  - 2. Joint-sealant manufacturer and product name.
  - 3. Joint-sealant formulation.
  - 4. Joint-sealant color.

1.3 INFORMATIONAL SUBMITTALS

- A. Product test reports.
- B. Preconstruction compatibility and adhesion test reports.
- C. Preconstruction field-adhesion test reports.
- D. Field-adhesion test reports.
- E. Warranties.

1.4 WARRANTY

- A. Special Installer's Warranty: Manufacturer's standard form in which Installer agrees to repair or replace joint sealants that do not comply with performance and other requirements specified in this Section within specified warranty period.
  - 1. Warranty Period: Two years from date of Substantial Completion.
- B. Special Manufacturer's Warranty: Manufacturer's standard form in which joint-sealant manufacturer agrees to furnish joint sealants to repair or replace those that do not comply with performance and other requirements specified in this Section within specified warranty period.

## JOINT SEALANTS

1. Warranty Period: Two years from date of Substantial Completion.

### PART 2 - PRODUCTS

#### 2.1 MATERIALS, GENERAL

- A. VOC Content of Interior Sealants: Sealants and sealant primers used inside the weatherproofing system shall comply with the following limits for VOC content when calculated according to 40 CFR 59, Subpart D (EPA Method 24):
  1. Architectural Sealants: 250 g/L.
  2. Sealant Primers for Nonporous Substrates: 250 g/L.
  3. Sealant Primers for Porous Substrates: 775 g/L.
- B. Low-Emitting Interior Sealants: Sealants and sealant primers used inside the weatherproofing system shall comply with the testing and product requirements of the California Department of Health Services' "Standard Practice for the Testing of Volatile Organic Emissions from Various Sources Using Small-Scale Environmental Chambers."
- C. Liquid-Applied Joint Sealants: Comply with ASTM C 920 and other requirements indicated for each liquid-applied joint sealant specified, including those referencing ASTM C 920 classifications for type, grade, class, and uses related to exposure and joint substrates.
  1. Suitability for Immersion in Liquids. Where sealants are indicated for Use I for joints that will be continuously immersed in liquids, provide products that have undergone testing according to ASTM C 1247. Liquid used for testing sealants is deionized water, unless otherwise indicated.
- D. Stain-Test-Response Characteristics: Where sealants are specified to be nonstaining to porous substrates, provide products that have undergone testing according to ASTM C 1248 and have not stained porous joint substrates indicated for Project.
- E. Suitability for Contact with Food: Where sealants are indicated for joints that will come in repeated contact with food, provide products that comply with 21 CFR 177.2600.

#### 2.2 SILICONE JOINT SEALANTS

- A. Mildew-Resistant Silicone Joint Sealants: ASTM C 920.
  1. Manufacturers: Subject to compliance with requirements, available manufacturers offering products that may be incorporated into the Work include, but are not limited to, the following:
    - a. BASF Building Systems.
    - b. Dow Corning Corporation.
    - c. GE Advanced Materials - Silicones.
    - d. May National Associates, Inc.

## JOINT SEALANTS

- e. Pecora Corporation.
  - f. Polymeric Systems, Inc.
  - g. Schnee-Morehead, Inc.
  - h. Sika Corporation; Construction Products Division.
  - i. Tremco Incorporated.
2. Type: multicomponent (M)
  3. Grade: nonsag (NS).
  4. Class: 100/50
  5. Uses Related to Exposure: Nontraffic (NT)

### 2.3 URETHANE JOINT SEALANTS

#### A. Urethane Joint Sealant [US <#>]: ASTM C 920.

1. Manufacturers: Subject to compliance with requirements, available manufacturers offering products that may be incorporated into the Work include, but are not limited to, the following:
  - a. BASF Building Systems.
  - b. Bostik, Inc.
  - c. Lyntal, International, Inc.
  - d. May National Associates, Inc.
  - e. Pacific Polymers International, Inc.
  - f. Pecora Corporation.
  - g. Polymeric Systems, Inc.
  - h. Schnee-Morehead, Inc.
  - i. Sika Corporation; Construction Products Division.
  - j. Tremco Incorporated.
2. Type: multicomponent (M)
3. Grade: nonsag (NS)
4. Class: 50
5. Uses Related to Exposure: Nontraffic (NT)

### 2.4 LATEX JOINT SEALANTS

#### A. Latex Joint Sealant: Acrylic latex or siliconized acrylic latex, ASTM C 834, Type OP, Grade NF.

1. Manufacturers: Subject to compliance with requirements, available manufacturers offering products that may be incorporated into the Work include, but are not limited to, the following:
  - a. BASF Building Systems.
  - b. Bostik, Inc.
  - c. May National Associates, Inc.
  - d. Pecora Corporation.
  - e. Schnee-Morehead, Inc.

## JOINT SEALANTS

- f. Tremco Incorporated.

### 2.5 ACOUSTICAL JOINT SEALANTS

- A. Acoustical Joint Sealant: Manufacturer's standard nonsag, paintable, nonstaining latex sealant complying with ASTM C 834. Product effectively reduces airborne sound transmission through perimeter joints and openings in building construction as demonstrated by testing representative assemblies according to ASTM E 90.
  - 1. Manufacturers: Subject to compliance with requirements, available manufacturers offering products that may be incorporated into the Work include, but are not limited to, the following:
    - a. Pecora Corporation .
    - b. USG Corporation.

### 2.6 JOINT SEALANT BACKING

- A. Cylindrical Sealant Backings: ASTM C 1330, Type C (closed-cell material with a surface skin) and of size and density to control sealant depth and otherwise contribute to producing optimum sealant performance.
- B. Bond-Breaker Tape: Polyethylene tape or other plastic tape recommended by sealant manufacturer.

### 2.7 MISCELLANEOUS MATERIALS

- A. Primer: Material recommended by joint-sealant manufacturer where required for adhesion of sealant to joint substrates indicated, as determined from preconstruction joint-sealant-substrate tests and field tests.
- B. Cleaners for Nonporous Surfaces: Chemical cleaners acceptable to manufacturers of sealants and sealant backing materials.
- C. Masking Tape: Nonstaining, nonabsorbent material compatible with joint sealants and surfaces adjacent to joints.

## PART 3 - EXECUTION

### 3.1 PREPARATION

- A. Surface Cleaning of Joints: Clean out joints immediately before installing joint sealants to comply with joint-sealant manufacturer's written instructions.
  - 1. Remove laitance and form-release agents from concrete.

## JOINT SEALANTS

2. Clean nonporous joint substrate surfaces with chemical cleaners or other means that do not stain, harm substrates, or leave residues capable of interfering with adhesion of joint sealants.

B. Joint Priming: Prime joint substrates where recommended by joint-sealant manufacturer or as indicated by preconstruction joint-sealant-substrate tests or prior experience. Apply primer to comply with joint-sealant manufacturer's written instructions. Confine primers to areas of joint-sealant bond; do not allow spillage or migration onto adjoining surfaces.

C. Masking Tape: Use masking tape where required to prevent contact of sealant or primer with adjoining surfaces that otherwise would be permanently stained or damaged by such contact or by cleaning methods required to remove sealant smears. Remove tape immediately after tooling without disturbing joint seal.

### 3.2 INSTALLATION

A. Sealant Installation Standard: Comply with recommendations in ASTM C 1193 for use of joint sealants as applicable to materials, applications, and conditions indicated.

B. Install sealant backings of kind indicated to support sealants during application and at position required to produce cross-sectional shapes and depths of installed sealants relative to joint widths that allow optimum sealant movement capability.

1. Do not leave gaps between ends of sealant backings.
2. Do not stretch, twist, puncture, or tear sealant backings.
3. Remove absorbent sealant backings that have become wet before sealant application and replace them with dry materials.

C. Install bond-breaker tape behind sealants where sealant backings are not used between sealants and backs of joints.

D. Install sealants using proven techniques that comply with the following and at the same time backings are installed:

1. Place sealants so they directly contact and fully wet joint substrates.
2. Completely fill recesses in each joint configuration.
3. Produce uniform, cross-sectional shapes and depths relative to joint widths that allow optimum sealant movement capability.

E. Tooling of Nonsag Sealants: Immediately after sealant application and before skinning or curing begins, tool sealants according to requirements specified in subparagraphs below to form smooth, uniform beads of configuration indicated; to eliminate air pockets; and to ensure contact and adhesion of sealant with sides of joint.

1. Remove excess sealant from surfaces adjacent to joints.
2. Use tooling agents that are approved in writing by sealant manufacturer and that do not discolor sealants or adjacent surfaces.

## JOINT SEALANTS

3. Provide concave joint profile per Figure 8A in ASTM C 1193, unless otherwise indicated.

- F. Acoustical Sealant Installation: Comply with ASTM C 919 and with manufacturer's written recommendations.
- G. Clean off excess sealant or sealant smears adjacent to joints as the Work progresses by methods and with cleaning materials approved in writing by manufacturers of joint sealants and of products in which joints occur.

### 3.3 JOINT-SEALANT SCHEDULE

A. Joint-Sealant Application: Exterior joints in horizontal traffic surfaces.

1. Joint Locations:

- a. Control and expansion joints in brick pavers.
- b. Isolation and contraction joints in cast-in-place concrete slabs.
- c. Joints between plant-precaster architectural concrete paving units.
- d. Joints in stone paving units, including steps
- e. Tile control and expansion joints.
- f. Joints between different materials listed above.
- g. Other joints as indicated.

2. Joint Sealant: Silicone.

3. Joint-Sealant Color: As selected by Architect from manufacturer's full range of colors

B. Joint-Sealant Application: Exterior joints in vertical surfaces and horizontal nontraffic surfaces

1. Joint Locations:

- a. Construction joints in cast-in-place concrete.
- b. Joints between plant-precaster architectural concrete units.
- c. Control and expansion joints in unit masonry.
- d. Joints in dimension stone cladding.
- e. Joints in glass unit masonry assemblies.
- f. Joints in exterior insulation and finish systems.
- g. Joints between metal panels.
- h. Joints between different materials listed above.
- i. Perimeter joints between materials listed above and frames of doors, windows and louvers
- j. Control and expansion joints in ceilings and other overhead surfaces

2. Joint Sealant: Silicone.

3. Joint-Sealant Color: As selected by Architect from manufacturer's full range of colors

C. Joint-Sealant Application: Interior joints in horizontal traffic surfaces



## JOINT SEALANTS

1. Joint Locations:
    - a. Isolation joints in cast-in-place concrete slabs.
    - b. Control and expansion joints in tile flooring.
    - c. Other joints as indicated.
  2. Joint Sealant: Urethane.
  3. Joint-Sealant Color: As selected by Architect from manufacturer's full range of colors
- D. Joint-Sealant Application: Interior joints in vertical surfaces and horizontal nontraffic surfaces.
1. Joint Locations:
    - a. Control and expansion joints on exposed interior surfaces of exterior walls.
    - b. Perimeter joints of exterior openings where indicated.
    - c. Tile control and expansion joints.
    - d. Vertical joints on exposed surfaces of concrete, walls, and partitions
    - e. Perimeter joints between interior wall surfaces and frames of interior doors windows and elevator entrances.
    - f. Other joints as indicated.
  2. Joint Sealant: Latex.
  3. Joint-Sealant Color: As selected by Architect from manufacturer's full range of colors
- E. Joint-Sealant Application: Mildew-resistant interior joints in vertical surfaces and horizontal nontraffic surfaces.
1. Joint Sealant Location:
    - a. Joints between plumbing fixtures and adjoining walls, floors, and counters.
    - b. Tile control and expansion joints where indicated.
    - c. Other joints as indicated.
  2. Joint Sealant: Silicone.
  3. Joint-Sealant Color: [As selected by Architect from manufacturer's full range of colors
- F. Joint-Sealant Application: Interior acoustical joints in vertical surfaces and horizontal nontraffic surfaces
1. Joint Location:
    - a. Acoustical joints where indicated.
    - b. Other joints as indicated.
  2. Joint Sealant: Acoustical.
  3. Joint-Sealant Color: As selected by Architect from manufacturer's full range

**JOINT SEALANTS**

END OF SECTION

**DIVISION 08**

**OPENINGS**

**THIS PAGE LEFT BLANK INTENTIONALLY**

**SECTION 08 2710  
FINISH HARDWARE**

**PART 1**

**GENERAL**

1.1 DESCRIPTION

A. Scope:

1. The CONTRACTOR shall provide all labor, materials, equipment and incidentals as shown, specified and required to furnish and install finish hardware.
2. Extent of finish hardware is specified. Finish hardware is defined to include all items known commercially as finish hardware, except special types of unique and non-matching hardware specified in the same Section as the door and door frame.
3. Types of products required include the following:
  - a. Mortise hinges.
  - b. Stripping and seals.
  - c. Thresholds.
  - d. Miscellaneous items and accessories for a complete installation functioning in compliance with the requirements of governing authorities having jurisdiction at the Site.

B. Coordination:

1. Review installation procedures under other Sections and coordinate the installation of items that must be installed with, or before, the finish hardware.
2. Coordinate the Work of other Sections to provide clearances and accurate positioning of recessed or cast-in-place items.

C. Related Sections:

1. Section 08 2200, Plastic Doors and Frames

1.2 QUALITY ASSURANCE

A. Reference Standards: Comply with the latest edition of the applicable provisions and recommendations of the following, except as otherwise shown or specified:

1. ANSI A117.1, Accessible and Usable Buildings and Facilities.
2. ANSI in association with Builders Hardware Manufacturers Association, ANSI/BHMA A156.1, Butts and Hinges.
3. ANSI in association with Builders Hardware Manufacturers Association, ANSI/BHMA A156.4, Door Controls - Closers.
4. ANSI in association with Builders Hardware Manufacturers Association, ANSI/BHMA A156.6, Architectural Door Trim.
5. ANSI in association with Builders Hardware Manufacturers Association, ANSI/BHMA A156.7, Template Hinge Dimensions.
6. ANSI in association with Builders Hardware Manufacturers Association, ANSI/BHMA A156.8, Door Controls - Overhead Stops and Holders.
7. ANSI in association with Builders Hardware Manufacturers Association, ANSI/BHMA A156.13, Locks and Latches, Mortise.
8. ANSI in association with Builders Hardware Manufacturers Association, ANSI/BHMA A156.16, Auxiliary Hardware.

## FINISH HARDWARE

9. ANSI in association with Builders Hardware Manufacturers Association, ANSI/BHMA A156.18, Hardware - Materials and Finishes.
  10. ANSI in association with Builders Hardware Manufacturers Association, ANSI/BHMA A156.21, Thresholds.
  11. ANSI in association with Builders Hardware Manufacturers Association, ANSI/BHMA A156.22, Door Gasketing Systems.
  12. ANSI in association with Door and Hardware Institute, ANSI/DHI A115.1, Preparation of Mortise Locks in 1-3/8-inch and 1-3/4-inch Standard Steel Doors and Frames.
  13. Door and Hardware Institute, DHI, Recommended Locations for Builders' Hardware for Custom Steel Doors and Frames.
  14. Door and Hardware Institute, DHI, Sequencing and Format for the Hardware Schedule.
  15. Underwriters Laboratories Incorporated, UL, Building Materials Directory.
- B. Manufacturer Qualifications:
1. Provide finish hardware and accessories manufactured by firms specializing in the production of this type of Work and complying with specified standards of ANSI, BHMA, DHI, NFPA, HMMA, SDI and UL.
  2. Provide finish hardware from manufacturers who are members of BHMA and participate in BHMA certification programs.
- C. Installer Qualifications: The finish hardware installer shall employ an architectural hardware consultant. The architectural hardware consultant shall be a member of the Door and Hardware Institute, who has passed the DHI certification exam and successfully completed an apprenticeship program. The architectural hardware consultant shall be responsible for preparing finish hardware schedules and Shop Drawings and be present at the Site for the purpose of checking and supervising the Work of the installer during the time of installation and adjustment of the finish hardware Work, and shall prepare a written field report on status of completed finish hardware installation as specified.
- D. Performance Criteria:
1. Where the finish, shape, size, frequency of use, or function of a member receiving finish hardware is such as to prevent, or make unsuitable, the types of finish hardware specified, furnish similar types having as nearly as practicable the same operation but of type or kind more appropriate to the design intension and requirements of governing authorities having jurisdiction. Clearly identify and highlight to the ENGINEER all such required modifications on Shop Drawings submitted for approval.
  2. If finish hardware for any location is not specified, provide finish hardware equal in design and quality to adjacent finish hardware specified for comparable openings at no additional expense to the OWNER.
  3. Furnish finish hardware items of proper design for use on doors and frames of the thickness, profile, swing, security and similar requirements, as necessary for proper installation and function.
- E. Source Quality Control:
1. Obtain each type of finish hardware item from only one manufacturer.

## **FINISH HARDWARE**

2. Provide finish hardware schedule, for submission to, and for approval by, the ENGINEER, prepared in compliance with DHI standards.
3. Comply with specified BHMA standards.

### 1.3 SUBMITTALS

- A. Shop Drawings: Submit for approval the following:
1. Copies of manufacturer's data for each item of finish hardware. Include whatever information may be necessary to show compliance with specified requirements, and include instructions for installation and for maintenance of operating parts and exposed finishes. Include mounting heights and locations for each item of finish hardware. Provide the ENGINEER with latest complete technical catalogue of all available finish hardware manufactured by proposed manufacturers, even if manufacturer specified by the ENGINEER is submitted by the CONTRACTOR to perform the Work. Furnish templates to fabricators of other work which is to receive finish hardware.
  2. Copies of the finish hardware schedule in the manner and format specified, complying with the actual construction progress schedule requirements (for each draft). Include explanation of abbreviations, symbols, and codes used to present scheduled information.
  3. Based on the finish hardware requirements specified, organize the final finish hardware schedule into "hardware sets," indicating complete designation of every item required for each door or opening. Furnish initial draft of schedule at the earliest possible date, in order to facilitate the fabrication of other Work, which may be critical in the Project construction schedule. Furnish final draft of schedule after samples, manufacturer's data sheets, coordination with Shop Drawings for other Work, delivery schedules and similar information have been completed and accepted.
  4. Include a separate key schedule, showing clearly how the OWNER's final instructions on keying of locks have been fulfilled.
  5. Finish hardware schedules are intended for coordination of the Work. Review and acceptance by the ENGINEER does not relieve the CONTRACTOR of responsibility to fulfill the requirements as shown and specified.
  6. Maintenance Manual: Upon completion of the Work, furnish copies of detailed maintenance manuals, including the following information:
    - a. Product name and manufacturer.
    - b. Name, address and telephone number of manufacturer and local distributor.
    - c. Detailed procedure for routine maintenance and cleaning.
    - d. Detailed procedures for repairs such as dents, scratches and staining.
    - e. Parts identification manual and maintenance manuals for each piece of finish hardware.
- B. Samples: Submit for approval the following:
1. Actual unit of each finish hardware item specified incorporating all standard and special features and finishes specified, demonstrated and

## FINISH HARDWARE

identified by manufacturer's representative to the ENGINEER. Samples shall be presented at time of Shop Drawing submittal, as the ENGINEER will not review or approve Shop Drawings without concurrent sample submissions.

2. Approved samples may be incorporated into the finish hardware Work.
3. The ENGINEER's review will be for appearance and for general compliance with required features. Compliance with all other requirements is the responsibility of the CONTRACTOR.

- C. Test Reports: Submit for approval certified independent laboratory test reports for BHMA certification program and certification tests for each type of product specified.

### 1.4 PRODUCT DELIVERY, STORAGE AND HANDLING

#### A. Delivery of Materials:

1. Deliver items of finish hardware sufficiently in advance of their setting for proper inspection.
2. Deliver all items of finish hardware in manufacturer's original, undamaged packages, bearing accurate representation of the item within each package.
3. Pack each piece of finish hardware separately, complete with screws, keying, instructions and templates, tagged to correspond with items submitted on approved Shop Drawings and as specified.
4. Inspect items upon delivery for damage. Items that arrive in damaged condition shall be permanently removed from the Site and not offered again for approval by the ENGINEER.

#### B. Storage of Materials:

1. Provide secure storage area for finish hardware items, secured by locks and accessible only to finish hardware installer, the ENGINEER and the CONTRACTOR.
2. Store finish hardware in manufacturers' original packages.

- C. Handling of Materials: Control the handling and installation of finish hardware items which are not immediately replaceable, so that the completion of the Work will not be delayed by finish hardware losses, both before and after installation.

### 1.5 JOB CONDITIONS

#### A. Scheduling:

1. Deliver individually packaged finish hardware items at the proper time to the proper locations for installation.
2. Coordinate with other Work by furnishing Shop Drawings, inserts, templates and similar items at the appropriate times for proper sequencing of construction without delays.

### 1.6 SUBSTITUTIONS

- A. Do not make substitutions after Shop Drawing and Sample approval by the ENGINEER.



## FINISH HARDWARE

- B. Standards: Manufacturers and model numbers listed establish a standard of quality.
- C. Clearly identify, in a manner which is highlighted to the ENGINEER, all proposed substitutions, modifications, variations, unspecified features and "or equal" products. Provide complete comparative data, with specified products, at time of Shop Drawing submission. Complete comparative data shall include all internal as well as external finish hardware components including, but not necessarily limited to, gages, diameters, thicknesses and kinds of material and their arrangement and function in the item under comparison.

## PART 2 PRODUCTS

### 2.1 MATERIALS AND FABRICATION

- A. General:
  - 1. Hand of Door: The Drawings show the swing or hand of each door leaf (left, right, reverse bevel, etc.). Furnish each item of finish hardware for proper installation and operation of the door swing as shown.
  - 2. Manufacturer's Name Plate: Do not use manufacturer's products which have manufacturer's name or trade name displayed in a visible location (omit removable nameplates), except in conjunction with labels required by governing authorities.
  - 3. Base Metals: Produce finish hardware units of the basic metal and forming method specified, using the manufacturer's standard metal alloy, composition, temper and hardness. Do not substitute materials or forming methods for those specified.
  - 4. Fasteners: Manufacture finish hardware to conform to published templates, generally prepared for machine screw installation. Do not provide finish hardware which has been prepared for self-tapping sheet metal screws, except as specifically indicated.
  - 5. Furnish screws for installation, with each finish hardware item. Provide Phillips flat-head screws except as otherwise specified. Finish exposed (exposed under any condition) screws to match the hardware finish or, if exposed in surfaces on other Work, to match the finish of such other Work as closely as possible, including "prepared for paint" in surfaces to receive painted finish.
  - 6. Provide fasteners which are compatible with both the unit fastened and the substrate, and which will not cause corrosion or deterioration of finish hardware, base material or fastener.
  - 7. Provide concealed fasteners for finish hardware units which are not exposed when the door is closed, except to the extent no standard manufacturer units of the type specified are available with concealed fasteners. Do not use through bolts for installation where the bolt head or the nut on the opposite face is exposed in other Work under any condition, except where it is not possible to adequately reinforce the Work and use machine screws or concealed fasteners of another standard type to satisfactorily avoid the use of through bolts.
  - 8. Tools for Maintenance: Furnish a complete set of specialized tools as needed for the OWNER's continued adjustment, maintenance, removal and replacement of finish hardware.

## FINISH HARDWARE

- B. MORTISE HINGES:
1. Templates and Screws: Provide only template-produced units.
  2. Base Metal: Except as otherwise specified, fabricate hinges from stainless steel and finish to match the latch and lock set.
  3. Number of Hinges: Provide three hinges on each door leaf of less than 60-inches in height; provide one additional hinge for next 30-inches of door height or fraction thereof; provide two additional hinges for each 30-inches, or fraction thereof, for doors above 90-inches tall.
  4. Hinge Size: Except as otherwise specified or as required to comply with UL and NFPA, provide hinges of the following sizes:
    - a. Exterior Doors, maximum 36-inches wide: 4 1/2-inch heavy weight (0.180-inch).
  5. Types of Hinges: Provide full-mortise type, ball-bearing hinges, swaged for mortise applications, inner leaf beveled, square cornered, unless manufacturer's recommendations indicate that half-mortise, half-surface, full-surface or other type should be used for the frame and door type or condition.
  6. Hinge Pins: Except as otherwise specified, provide hinge pins as follows:
    - a. Pins: Stainless steel.
    - b. Exterior Doors: Non-removable pins. Provide set screw in hinge barrel that, when tightened into a groove in hinge pin, prevents removal of pin while door is closed.
    - c. Tips: Slope ends of hinge barrel.
  7. ANSI/BHMA: A156.7.
  8. Product and Manufacturer: Provide one of the following:
    - a. FBB 199 and FBB 191 by Stanley Commercial Hardware, Division of The Stanley Works.
    - b. T4B3386 and TB3313 by McKinney Products Company, Division of ESSEX Industries, Incorporated.
    - c. Or equal.
- C. STRIPPING AND SEALS:
9. Provide perimeter weather stripping at all exterior doors.
  10. Continuity of Stripping: Except as otherwise specified, stripping at each opening shall be continuous and without unnecessary interruptions at door corners and hardware.
  11. Replaceable Seal Strips: Resilient or flexible seal strip of every unit shall be easily replaceable and readily available from stocks maintained by the manufacturer.
  12. Provide bumper-type weatherstripping at jambs and head, including a resilient insert and metal retainer strip, surface-applied, of the following metal, finish and resilient bumper material:
    - a. Housing: Extruded aluminum with dark bronze anodized finish; 0.062-inch minimum thickness of main walls and flanges.
    - b. Dimensions: 1-3/8-inches by 7/8-inches; stop-mounted.
    - c. Seals: Closed-cell extruded silicone.
    - d. ANSI/BHMA: A156.22, R3E264.
    - e. Product and Manufacturer: Provide one of the following:
      - 1.) No. 350DSPK and 2891 DPK (for parallel arms) by Pemko Manufacturing Company.
      - 2.) Or equal.

## FINISH HARDWARE

- D. Thresholds:
1. All exterior and interior doors shall be provided with thresholds.
  2. Metal: Mill finish extruded bronze.
  3. Surface Pattern: Fluted tread, manufacturer's standard.
  4. Provide countersunk stainless steel screws and expansion shields.
  5. Width: 5-inches wide and of length sufficient to span full width of rough openings; coped and scribed neatly at and around door frames.
  6. Construction:
    - a. Single-piece, complying with manufacturer's recommendations.
  7. Profile: Provide manufacturer's unit which conforms with the minimum size and profile requirements specified.
    - a. Floor Drop: Except where no change in floor elevation is shown from one side of threshold to the other, provide profile that accommodates 1/2 inch drop in floor elevation, unless another dimension is shown.
  8. Thickness: 1/2-inch minimum.
  9. ANSI/BHMA: A156.21, J12100.
  10. Product and Manufacturer: Provide one of the following:
    - a. 171B by Pemko Manufacturing Company.
    - b. Or equal.
- E. Stops and Bumpers: Provide floor stops for doors unless wall or other type stops are scheduled or indicated. Do not mount floor stops where they will impede traffic. Where floor or wall stops are not appropriate, provide overhead holders.
- F. Sealants: Provide elastomeric sealant complying with FS TT-S-00227, Type 2 (non-sag) Class A for use with thresholds.

### 2.2 HARDWARE FINISHES

- A. Provide matching finishes for finish hardware units at each door or opening, to the greatest extent possible in compliance with ANSI/BHMA A156.18.
- B. Reduce differences in color and textures as much as commercially possible where the base metal or metal forming process is different for individual units of finish hardware exposed at the same door or opening. In general, match all items to the manufacturer's standard finish for the latch and lock set for color and texture.

## PART 3 EXECUTION

### 3.1 INSPECTION

- A. The CONTRACTOR and installer shall examine the substrate to receive finish hardware, and the conditions under which the Work will be performed, and notify the ENGINEER in writing of unsatisfactory conditions. Do not proceed with the finish hardware Work until unsatisfactory conditions have been corrected in a manner acceptable to the ENGINEER.

### 3.2 PREPARATION

## FINISH HARDWARE

- A. Templates: Furnish finish hardware templates to each fabricator of doors, frames and other Work to be factory-prepared for the installation of finish hardware. Check the Shop Drawings of such other Work, to confirm that adequate provisions are made for the proper installation of the finish hardware.
- B. Prepare Work to receive finish hardware Work in compliance with ANSI/DHI A115.1.

### 3.3 INSTALLATION

- A. Mount finish hardware units at heights recommended in, Door and Hardware Institute, "Recommended Locations for Architectural Hardware for Standard Steel Doors and Frames" and "Recommended Locations for Builders' Hardware for Custom Steel Doors and Frames", except as otherwise specified or required to comply with governing authorities having jurisdiction at the Site, HMMA 830 and ADAAG requirements.
- B. Install each finish hardware item in compliance with the manufacturer's instructions and recommendations and approved Shop Drawings. Wherever cutting and fitting is required to install finish hardware onto or into surfaces which are later to be painted or finished in another way, install each item completely and then remove and store in a secure place during the finish application. After completion of the finishes, re-install each item. Do not install surface-mounted items until finishes have been completed on the substrate.
- C. Set units level, plumb and true to line and location. Adjust and reinforce the attachment substrate as necessary for proper installation and operation.
- D. Drill and countersink units which are not factory-prepared for anchorage fasteners. Space fasteners and anchors in accordance with industry standards.
- E. Cut and fit threshold and floor covers to profile of door frames, with mitered corners and hair-line joints. Join units with concealed welds or concealed mechanical joints. Cut smooth openings for spindles, bolts and similar items, if any.
- F. Screw thresholds to substrate with No. 10 or larger screws, of the proper type for permanent anchorage and of bronze or stainless steel which will not corrode in contact with the threshold metal.
- G. Set thresholds in a bead of elastomeric sealant to completely fill concealed voids and exclude moisture from every source. Do not plug drainage holes or block weeps. Remove excess sealant before sealant cures to a firm set.

### 3.4 FIELD QUALITY CONTROL

- A. Provide a written field report, prepared by installer's architectural hardware consultant, identifying actual condition, location, manufacturer, and product designation for each item of finish hardware actually present on each door at the Site, including whether finish hardware is adjusted and operating properly,

## FINISH HARDWARE

compared with each item referenced to approved Shop Drawings and Contract requirements.

- B. Installer's hardware consultant shall provide opinions to, and assist the ENGINEER in determining, acceptability of installation as Work proceeds. All comments and discussions, conversations and meetings with the ENGINEER shall be included in written field report for submission to the ENGINEER for review and approval at completion of finish hardware installation.
- C. As part of written field report to be submitted to the ENGINEER for approval, recommend remedial actions for Work not in compliance with the Specifications. No payment for Work shall be made until remedial recommendations and actions have been approved by the ENGINEER and incorporated into the Work.

### 3.5 ADJUSTMENT AND CLEANING

- A. Adjust and check each operating item of finish hardware and each door, to ensure proper operation or function of every unit. Lubricate moving parts with the type lubrication recommended by manufacturer (graphite-type if no other recommended). Replace units which cannot be adjusted and lubricated to operate freely and smoothly as intended for the application.
- B. Final Adjustment: Where finish hardware installation is made more than one month prior to Substantial Completion, return to the Work during the week prior to acceptance or occupancy, and make a final check and adjustment of all finish hardware items in each space and area. Clean and relubricate operating items as necessary to restore proper function and finish of finish hardware and doors. Adjust door control devices to compensate for final operating of heating and ventilating equipment.
- C. Provide manufacturer's authorized representative to instruct and train the OWNER's personnel in proper adjustment and maintenance of finish hardware during the final adjustment of finish hardware.
- D. Finish hardware which is blemished or defective will be rejected even though it was set in place before defects were discovered. Remove and replace with new finish hardware. Repair all resultant damage to other Work.
- E. Continued Maintenance Service: Approximately six months after the acceptance of finish hardware in each area, the installer, accompanied by the representative of the latch and lock manufacturer, shall return to the Project and re-adjust every item of hardware to restore proper function of doors and finish hardware. Consult with and instruct the OWNER's personnel in recommended additions to the maintenance procedures. Clean and lubricate operational items wherever required. Replace finish hardware items which have deteriorated or failed due to faulty design, materials or installation of finish hardware units. Prepare a written report of current and predictable problems (of substantial nature) in the performance or the finish hardware.

### 3.6 PROTECTION

## **FINISH HARDWARE**

- A. Provide for the proper protection of all items of hardware until the OWNER accepts the project as complete. Damaged or disfigured hardware shall be replaced or repaired.

### **3.7 LIST OF FINISH HARDWARE ITEMS**

- A. Scheduled items for each door are generic and rely on information specified above. The listing of hardware functions and types provided are only a general guideline for the final finish hardware schedule. The CONTRACTOR shall submit a finish hardware schedule acceptable to all governing authorities having jurisdiction at the Site.

END OF SECTION

**SECTION 08 31 20**  
**FLOOR, PIT AND SIDEWALK HATCHES**

**PART 1 - GENERAL**

**1.1 SUMMARY**

- A. Scope:
  - 1. Extent, location, and size of each type of floor, pit, and sidewalk hatches required as indicated on Drawings.
  - 2. Floor, pit, and sidewalk hatches shall be of single- or double-leaf construction of the size and as shown on Drawings.
- B. Design Requirements:
  - 1. Structural Performance: Provide covers and units capable of withstanding a live load of 300 pounds per square foot with a maximum deflection of 1/150 of the span unless otherwise indicated. Provide H-20 reinforcing for 16,000-pound wheel load where indicated.

**1.2 QUALITY ASSURANCE**

- A. Single Source Responsibility: Provide floor, pit, and sidewalk hatches, frames, hardware, and related items produced by a single manufacturer capable of showing prior production of floor, pit, and sidewalk hatches assemblies similar to those required.
- B. Size Variations: Obtain ENGINEER's acceptance of manufacturer's standard size units which may vary slightly from sizes indicated.
- C. Coordination: Provide inserts and anchoring devices which must be built into other Work for installation of floor, pit, and sidewalk hatches. Coordinate delivery with other Work to avoid delay.

**1.3 DEFINITIONS (NOT USED)**

**1.4 SUBMITTALS**

- A. Shop Drawings: Submit in accordance with Section 01 340, Shop Drawings, covering the items included under this Section. Shop Drawing submittals shall include:
  - 1. Drawings for fabrication and installation of all floor, pit, and sidewalk hatches and frames, including details of each frame type, elevations of hatch design types, anchorage, and accessory items.
  - 2. Product Data: Submit manufacturer's technical data and installation instructions for each type of floor, pit, and sidewalk hatch assembly, including setting drawings, templates, and instructions and directions for installation of anchorage devices.
    - a. Include complete schedule including types, general locations, sizes, floor, pit, and sidewalk construction details, finishes, hardware information, latching or locking provisions, and other data pertinent to installation.
  - 3. Verification: Obtain specific locations and sizes for required floor, pit, and sidewalk hatches from trades and manufacturers requiring access to equipment, and indicate on Submittal Schedule.
  - 4. Special Size and Load Floor, Pit, and Sidewalk Hatches: Use where required or requested as indicated on Drawing Schedule.

## **FLOOR, PIT AND SIDEWALK HATCHES**

5. Samples: 3 inches by 5 inches minimum size, of each cover face material showing factory finished color, pattern, and texture.
- B. Submittals Sequence: Submit Schedule, Product Data, and Shop Drawings at earliest possible date, particularly where acceptance must precede fabrication of other work (e.g., concrete work) which is critical in the Project Construction Schedule. Include the product data, samples, Shop Drawings of other work affected by floor, pit, and sidewalk hatches, and other information essential to the coordinated review of same.

### **1.5 WARRANTY**

- A. Special Warranty: Submit a written warranty, executed by the manufacturer, agreeing to repair or replace components or entire units which fail in materials or workmanship within the specified warranty period. Failures include, but are not necessarily limited to, structural failure including excessive deflection, excessive water leakage, faulty operation of hardware, deterioration of metals, metal finishes and other materials beyond normal weathering.
  1. Warranty period for floor, pit, and sidewalk hatch units shall be five (5) years after the date of Substantial Completion.

### **1.6 PROJECT CONDITIONS**

- A. Field Measurement: Where possible, field measure openings before fabrication to ensure proper fit of work; show measurements on final Shop Drawings. Coordinate fabrication with construction progress to avoid delay. If necessary, proceed with fabrication without measurements, and coordinate tolerances to ensure proper fit.

## **PART 2 - PRODUCTS**

### **2.1 MANUFACTURERS**

- A. Subject to compliance with specified requirements, manufacturers offering products which may be incorporated in Work include:
  1. Floor, Pit, and Sidewalk Hatches:
    - a. The Bilco Company.
    - b. Halliday Hatch
    - c. OWNER approved equal.

### **2.2 MATERIALS AND FABRICATION**

- A. Provide each floor, pit, or sidewalk hatch assembly manufactured as an integral unit, complete with all parts and ready for installation.
- B. Stainless Steel Floor, Pit, and Sidewalk Hatches and Frames: Fabricate units of continuous welded stainless steel construction unless otherwise indicated. Grind welds smooth and flush with adjacent surfaces. Furnish attachment devices and fasteners of type required to secure frames to types of floor or walkway shown on Drawings.
- C. Covers: Covers shall be stainless steel 1/4-inch diamond pattern, reinforced on the underside. Covers shall open to 90 degrees and lock automatically in that position.
- D. Channel Frame: Fabricate channel frame from 16 –gauge, No.4 satin finish stainless



## FLOOR, PIT AND SIDEWALK HATCHES

steel with full anchor angle welded around perimeter for concrete installation.

- E. For watertightness, furnish frame with formed gutters a minimum of 3-inch wide by 3-inch deep, anchors, and a welded 1-1/2-inch drain coupling located on the right front corner of the channel frame or in another corner if shown on Drawings or specified otherwise. Fully weld gutter frame for absolute weathertightness.
- F. Hinges, Pins, Bolts, and Nuts: Provide the covers with heavy 12 gauge, No. 316 stainless steel hinges and stainless steel pins. Hinges shall pivot so the cover does not protrude into channel frame. Hinges shall be through-bolted to the cover with stainless steel lock bolts and shall be through-bolted to the frame with stainless steel bolts and lock nuts.
- G. Springs, Tubes, Shoes, Plates, Enclosures, and Operators: Provide the covers with manufacturer's standard springs, tubes and caps, tube or spring enclosures, operators, support plates, and shoes, which shall allow ease of operation through the entire 90-degree arc of opening, and act as a check in retarding downward motion when being closed. Tube and spring enclosures shall prevent accumulation of moisture, grit, and debris inside the tube and spring assembly.
- H. Hold-Open Arms: Provide the covers with hold-open arms with guides which automatically lock the covers in the open position. Vinyl covered release handles shall be provided and conveniently located for closing.
- I. Interior Snap Lock and Lock Strike: Provide a stainless steel snap lock and lock strike with a stainless steel fixed turn handle and appropriate stainless steel bolts mounted on the underside of the covers.
- J. Exterior Lift Handle: Provide the covers with a stainless steel lift handle designed to be flush with walking surface when not in use.
- K. Exterior Locking and Latching Devices: Provide the covers with the following locking or latching device and related hinged lid, flush gasketed removable screw plug, or threaded cover plug as noted:
  - 1. Cylinder Lock: Provide a brass cylinder lock with keyway protected by a threaded cover plug. Provide one cylinder lock per hatch. Furnish two keys per lock. Key all locks alike.
- L. Hardware Finish: Except where noted otherwise, all hardware shall be zinc plated and chromate sealed.

### 2.3 ACCESSORIES

- A. Provide ladder safety posts at fixed ladders located below floor hatches and roof hatches. Safety posts shall be designed with telescoping section that locks automatically when fully extended. Up and down movement shall be controlled by a stainless steel spring balancing mechanism. Unit shall be completely assembled with fasteners for securing to ladder rungs in accordance with manufacturer's instructions. Finish to match ladder served.
  - 1. Safety post shall be Bilco Ladder Up, or approved equal.
- B. Provide rigid aluminum safety grate below floor hatches. The safety grate shall be a permanently installed system that is easily retractable for full access and allows visibility for inspection. The product must be corrosion resistant and tested and

## **FLOOR, PIT AND SIDEWALK HATCHES**

certified to meet current OSHA Standard 1926.502 (c) (4) (i) drop test. All metallic components, hinges, hardware hooks, and anchors shall be fabricated from Type 316 stainless steel. Safety grate shall be painted bright orange.

### **PART 3 - EXECUTION**

#### **3.1 EXAMINATION (NOT USED)**

#### **3.2 INSTALLATION**

- A. Comply with manufacturer's instructions for installation of floor, pit, and sidewalk hatches.
- B. Preparatory Work: For normal flush installation, set frames accurately in position, recessed below the finished grade or floor level with cover face panels plumb or level in relationship to adjacent finish surfaces. If unit is watertight type, unit should be set with slight pitch in direction of drain coupling. All four corners of the frame shall be in the same plane; verify that leaves are seated properly on frame all around. Securely attach units to supports.
- C. Method: For flush installation, pour concrete to top of frame.
- D. Coordinate installation with Work of other trades.

#### **3.3 ADJUST AND CLEAN**

- A. Adjust hardware and covers after installation for proper operation.
- B. Remove and replace covers or frames which are warped, bowed, or otherwise damaged.

**END OF SECTION**

**SECTION 08 51 13  
ALUMINUM WINDOWS**

**PART 1 - GENERAL**

1.1 SUMMARY

- A. Section includes aluminum windows for exterior locations.

1.2 ACTION SUBMITTALS

- A. Product Data: For each type of product.
- B. Shop Drawings: Include plans, elevations, sections, hardware, accessories, insect screens, operational clearances, and details of installation, including anchor, flashing, and sealant installation.
- C. Product Schedule: For aluminum windows. Use same designations indicated on Drawings.

1.3 INFORMATIONAL SUBMITTALS

- A. Product test reports.
- B. Sample warranties.

1.4 QUALITY ASSURANCE

- A. Mockups: Build mockups to verify selections made under Sample submittals and to demonstrate aesthetic effects and set quality standards for materials and execution.

1.5 WARRANTY

- A. Manufacturer's Warranty: Manufacturer agrees to repair or replace aluminum windows that fail in materials or workmanship within specified warranty period.

1. Warranty Period:

- a. Window: 10 years from date of Substantial Completion.
- b. Glazing Units: 10 years from date of Substantial Completion.
- c. Aluminum Finish: 10 years from date of Substantial Completion.
- d. Screens: 1 year from date of Substantial Completion.

## ALUMINUM WINDOWS

### PART 2 - PRODUCTS

#### 2.1 MANUFACTURERS

- A. Pella,
- B. Anderson,
- C. Approved equal.

#### 2.2 WINDOW PERFORMANCE REQUIREMENTS

- A. Product Standard: AAMA/WDMA/CSA 101/I.S.2/A440.
  - 1. Minimum Performance Class: R
  - 2. Minimum Performance Grade: 15
- B. Thermal Transmittance: NFRC 100 maximum whole-window U-factor of 0.35 Btu/sq. ft. x h x deg F
- C. Solar Heat-Gain Coefficient (SHGC): NFRC 200 maximum whole-window SHGC of 0.30
- D. Condensation-Resistance Factor (CRF): Provide aluminum windows tested for thermal performance according to AAMA 1503, showing a CRF of [45] [52] <Insert value>.

#### 2.3 ALUMINUM WINDOWS

- A. Operating Types: Fixed, Single Hung
- B. Frames and Sashes: Thermally broken aluminum extrusions complying with AAMA/WDMA/CSA 101/I.S.2/A440.
- C. Glass: Clear annealed glass, ASTM C 1036, Type 1, Class 1, q3.
- D. Glazing System: Manufacturer's standard factory-glazing system that produces weathertight seal.
- E. Fasteners: Noncorrosive and compatible with window members, trim, hardware, anchors, and other components.
  - 1. Exposed Fasteners: Do not use exposed fasteners to the greatest extent possible. For application of hardware, use fasteners that match finish hardware being fastened.

## ALUMINUM WINDOWS

### 2.4 ACCESSORIES

- A. Receptor System: Two-piece, snap-together, thermally broken, extruded-aluminum receptor system that anchors windows in place.
- B. Screen: Removable screens with a 2 foot by ½ width sliding panel to allow exterior wall observation without removing the entire screen. The sliding panel will be provided for six (6) of the window installations. The selected locations will be determined by the OWNER.

### 2.5 FABRICATION

- A. Fabricate aluminum windows in sizes indicated. Include a complete system for assembling components and anchoring windows.
- B. Glaze aluminum windows in the factory.
- C. Weather strip each operable sash to provide weathertight installation.
- D. Provide weep holes and internal passages to conduct infiltrating water to exterior.
- E. Provide water-shed members above side-hinged sashes and similar lines of natural water penetration.
- F. Provide mullions and cover plates, matching window units, complete with anchors for support to structure and installation of window units. Allow for erection tolerances and provide for movement of window units due to thermal expansion and building deflections, as indicated. Provide mullions and cover plates capable of withstanding design wind loads of window units.
- G. Complete fabrication, assembly, finishing, hardware application, and other work in the factory to greatest extent possible. Disassemble components only as necessary for shipment and installation.

### 2.6 ALUMINUM FINISHES

- A. Anodic Finish: Class I complying with AAMA 611.
  - 1. Color: Clear

## PART 3 - EXECUTION

### 3.1 INSTALLATION

- A. Comply with manufacturer's written instructions for installing windows, hardware, accessories, and other components. For installation procedures and requirements not addressed in manufacturer's written instructions, comply with installation requirements in ASTM E 2112.
- B. Install windows level, plumb, square, true to line, without distortion or impeding thermal movement, anchored securely in place to structural support, and in proper

## ALUMINUM WINDOWS

relation to wall flashing and other adjacent construction to produce weathertight construction.

- C. Install windows and components to drain condensation, water penetrating joints, and moisture migrating within windows to the exterior.
- D. Separate aluminum and other corrodible surfaces from sources of corrosion or electrolytic action at points of contact with other materials.
- E. Adjust operating sashes and hardware for a tight fit at contact points and weather stripping for smooth operation and weathertight closure.
- F. Clean exposed surfaces immediately after installing windows. Avoid damaging protective coatings and finishes. Remove excess sealants, glazing materials, dirt, and other substances.
- G. Remove and replace glass that has been broken, chipped, cracked, abraded, or damaged during construction period.

END OF SECTION

**SECTION 08 88 13  
FIRE-RESISTANT GLAZING**

**PART 1 - GENERAL**

1.1 SUMMARY

- A. Section Includes:
  - 1. Fire-protection-rated glazing.

1.2 COORDINATION

- A. Coordinate glazing channel dimensions to provide necessary bite on glass, minimum edge and face clearances, and adequate sealant thicknesses, with reasonable tolerances.

1.3 ACTION SUBMITTALS

- A. Product Data: For each type of product.
- B. Glass Samples: For each type of glass product; 12 inches (300 mm) square.
- C. Glazing Schedule: List glass types and thicknesses for each size opening and location. Use same designations indicated on Drawings.

1.4 WARRANTY

- A. Manufacturer's Special Warranty on Laminated Glass: Manufacturer agrees to replace laminated-glass units that deteriorate within specified warranty period. Deterioration of laminated glass is defined as defects developed from normal use that are not attributed to glass breakage or to maintaining and cleaning laminated glass contrary to manufacturer's written instructions. Defects include edge separation, delamination materially obstructing vision through glass, and blemishes exceeding those allowed by referenced laminated-glass standard.
  - 1. Warranty Period: 10 years from date of Substantial Completion.
- B. Manufacturer's Special Warranty on Double Glazing Units with Clear Gel Fill: Manufacturer agrees to replace units that deteriorate within specified warranty period. Deterioration of double glazing units with clear gel fill is defined as failure of hermetic seal under normal use that is not attributed to glass breakage or to maintaining and cleaning glass contrary to manufacturer's written instructions. Evidence of failure is the leakage of gel fill from units, air bubbles within units, or obstruction of vision by contamination or deterioration of gel.
  - 1. Warranty Period: 10 years from date of Substantial Completion.

## **FIRE-RESISTANT GLAZING**

### **PART 2 - PRODUCTS**

#### **2.1 GLASS PRODUCTS, GENERAL**

- A. Glazing Publications: Comply with published recommendations of glass product manufacturers and organization below unless more stringent requirements are indicated. Refer to these publications for glazing terms not otherwise defined in this Section or in referenced standards.

#### **2.2 GLASS PRODUCTS**

- A. Float Glass: ASTM C 1036, Type I, Quality-Q3, Class I (clear) unless otherwise indicated.

#### **2.3 FIRE-PROTECTION-RATED GLAZING**

- A. Fire-Protection-Rated Glazing: Listed and labeled by a testing agency acceptable to authorities having jurisdiction, for fire-protection ratings indicated, based on positive- pressure testing according to NFPA 257 or UL 9, including the hose-stream test, and shall comply with NFPA 80.

- 1. Fire-protection-rated glazing required to have a fire-protection rating of 20 minutes shall be exempt from the hose-stream test.

- B. Fire-Protection-Rated Glazing Labeling: Permanently mark fire-protection-rated glazing with certification label of a testing agency acceptable to authorities having jurisdiction. Label shall indicate manufacturer's name; test standard; whether glazing is permitted to be used in doors or openings; if permitted in openings, whether or not glazing has passed the hose-stream test; whether or not glazing meets 450 deg F (250 deg C) temperature-rise limitation; and the fire-resistance rating in minutes.

- C. Film-Faced Ceramic Glazing: Clear, ceramic flat glass; 5-mm thickness; faced on one surface with a clear glazing film; and complying with 16 CFR 1201, Category II.

#### **2.4 FIRE-RESISTANCE-RATED GLAZING**

- A. Fire-Resistance-Rated Glazing: Listed and labeled by a testing agency acceptable to authorities having jurisdiction, for fire-resistance ratings indicated, based on testing according to ASTM E 119 or UL 263.

- B. Fire-Resistance-Rated Glazing Labeling: Permanently mark fire-resistance-rated glazing with certification label of a testing agency acceptable to authorities having jurisdiction. Label shall indicate manufacturer's name, test standard, that the glazing is approved for use in walls, and the fire-resistance rating in minutes.



**SECTION 08 88 13  
FIRE-RESISTANT GLAZING**

**2.5 GLAZING ACCESSORIES**

- A. Provide glazing gaskets, glazing sealants, glazing tapes, setting blocks, spacers, edge blocks, and other glazing accessories that are compatible with glazing products and each other and are approved by testing agencies that listed and labeled fire-resistant glazing products with which products are used for applications and fire-protection ratings indicated.
- B. Glazing Sealants for Fire-Rated Glazing Products: Neutral-curing silicone glazing sealant complying with ASTM C 920, Type S, Grade NS, Class 50, Use NT. Comply with sealant and glass manufacturers' written instructions for selecting glazing sealants suitable for applications indicated.
  - 1. Colors of Exposed Glazing Sealants: As selected by Architect from manufacturer's full range

**PART 3 - EXECUTION**

**3.1 GLAZING**

- A. Use methods approved by testing agencies that listed and labeled fire-resistant glazing products.
- B. Comply with combined written instructions of manufacturers of glass, sealants, gaskets, and other glazing materials unless more stringent requirements are indicated, including those in referenced glazing publications.
- C. Protect glass edges from damage during handling and installation. Remove damaged glass from Project site and legally dispose of off Project site. Damaged glass is glass with edge damage or other imperfections that, when installed, could weaken glass and impair performance and appearance.
- D. Apply primers to joint surfaces where required for adhesion of sealants, as determined by preconstruction testing.
- E. Install setting blocks in sill rabbets, sized and located to comply with referenced glazing publications unless otherwise required by glass manufacturer. Set blocks in thin course of compatible sealant suitable for heel bead.
- F. Do not exceed edge pressures stipulated by glass manufacturers for installing glass lites.
- G. Provide spacers for glass lites where length plus width is larger than 50 inches (1270 mm).
- H. Provide edge blocking where indicated or needed to prevent glass lites from moving sideways in glazing channel, as recommended in writing by glass manufacturer and according to requirements in referenced glazing publications.

## **FIRE-RESISTANT GLAZING**

### **3.2 CLEANING AND PROTECTION**

- A. Immediately after installation, remove nonpermanent labels and clean surfaces.
- B. Protect glass from contact with contaminating substances resulting from construction operations. Examine glass surfaces adjacent to or below exterior concrete and other masonry surfaces at frequent intervals during construction, but not less than once a month, for buildup of dirt, scum, alkaline deposits, or stains.
  - 1. If, despite such protection, contaminating substances do come into contact with glass, remove substances immediately as recommended in writing by glass manufacturer.
- C. Remove and replace glass that is damaged during construction period.

### **3.3 FIRE-PROTECTION-RATED GLAZING SCHEDULE**

- A. Glass Type: 45-minute fire-protection-rated glazing; film-faced ceramic glazing

END OF SECTION

**DIVISION 09**

**FINISHES**

**THIS PAGE LEFT BLANK INTENTIONALLY**

**SECTION 09 91 23  
INTERIOR PAINTING**

**PART 1 - GENERAL**

1.1 SUMMARY

- A. Section includes surface preparation and the application of paint systems on the following interior substrates:
  - 1. Concrete.
  - 2. Concrete masonry units (CMUs).
  - 3. Galvanized metal.
  - 4. Gypsum board.

1.2 DEFINITIONS

- A. MPI Gloss Level 1: Not more than five units at 60 degrees and 10 units at 85 degrees, according to ASTM D 523.
- B. MPI Gloss Level 2: Not more than 10 units at 60 degrees and 10 to 35 units at 85 degrees, according to ASTM D 523.
- C. MPI Gloss Level 3: 10 to 25 units at 60 degrees and 10 to 35 units at 85 degrees, according to ASTM D 523.
- D. MPI Gloss Level 4: 20 to 35 units at 60 degrees and not less than 35 units at 85 degrees, according to ASTM D 523.
- E. MPI Gloss Level 5: 35 to 70 units at 60 degrees, according to ASTM D 523.
- F. MPI Gloss Level 6: 70 to 85 units at 60 degrees, according to ASTM D 523.

1.3 ACTION SUBMITTALS

- A. Product Data: For each type of product. Include preparation requirements and application instructions.
  - 1. Include Printout of current "MPI Approved Products List" for each product category specified, with the proposed product highlighted.
- B. Samples: For each type of paint system and in each color and gloss of topcoat.

## **INTERIOR PAINTING**

### **PART 2 - PRODUCTS**

#### **2.1 PAINT, GENERAL**

- A. MPI Standards: Products shall comply with MPI standards indicated and shall be listed in its "MPI Approved Products Lists."
- B. Material Compatibility:
  - 1. Materials for use within each paint system shall be compatible with one another and substrates indicated, under conditions of service and application as demonstrated by manufacturer, based on testing and field experience.
  - 2. For each coat in a paint system, products shall be recommended in writing by topcoat manufacturers for use in paint system and on substrate indicated.
- C. Colors: As selected by Architect from manufacturer's full range

### **PART 3 - EXECUTION**

#### **3.1 EXAMINATION**

- A. Examine substrates and conditions, with Applicator present, for compliance with requirements for maximum moisture content and other conditions affecting performance of the Work.
- B. Maximum Moisture Content of Substrates: When measured with an electronic moisture meter as follows:
  - 1. Concrete: 12 percent.
  - 2. Masonry (Clay and CMUs): 12 percent.
  - 3. Gypsum Board: 12 percent.
- C. Verify suitability of substrates, including surface conditions and compatibility with existing finishes and primers.
- D. Proceed with coating application only after unsatisfactory conditions have been corrected.
  - 1. Application of coating indicates acceptance of surfaces and conditions.

#### **3.2 PREPARATION**

- A. Comply with manufacturer's written instructions and recommendations in "MPI Architectural Painting Specification Manual" applicable to substrates and paint systems indicated.

## INTERIOR PAINTING

- B. Remove hardware, covers, plates, and similar items already in place that are removable and are not to be painted. If removal is impractical or impossible because of size or weight of item, provide surface-applied protection before surface preparation and painting.
  - 1. After completing painting operations, use workers skilled in the trades involved to reinstall items that were removed. Remove surface-applied protection if any.

### 3.3 APPLICATION

- A. Apply paints according to manufacturer's written instructions and recommendations in "MPI Architectural Painting Specification Manual."
- B. Apply paints to produce surface films without cloudiness, spotting, holidays, laps, brush marks, roller tracking, runs, sags, ropiness, or other surface imperfections. Cut in sharp lines and color breaks.

### 3.4 INTERIOR PAINTING SCHEDULE

- A. Concrete Substrates, Traffic Surfaces:
  - 1. Epoxy/Urethane System
    - a. Prime Coat: Modified polyamine fast-cure epoxy, clear color, Power-Tread FC Series 238 manufactured by Tnemec, or approved equal.
    - b. Topcoat: aliphatic moisture cured urethane, interior, high gloss (MPI Gloss Level 7), clear color, Everthane Series 247 manufactured by Tnemec, or approved equal.
    - c. Non slip additive: hardened glass beads Series 211 manufactured by Tnemec, or approved equal.
- B. Concrete Substrates, Non-traffic Surfaces:
  - 1. Latex System MPI INT 3.1A
    - a. Prime Coat: Primer, alkali resistant, water based, MPI #3
    - b. Prime Coat: Latex, interior, matching topcoat.
    - c. Intermediate Coat: Latex, interior, matching topcoat.
    - d. Topcoat: Latex, interior, flat (MPI Gloss Level 1), MPI #53
    - e. Topcoat: Latex, interior (MPI Gloss Level 4), MPI #43.
    - f. Topcoat: Latex, interior, gloss (MPI Gloss Level 6, except minimum gloss of 65 units at 60 degrees)[, MPI #114].
- C. CMU Substrates:
  - 1. Latex System MPI INT 4.2A:
    - a. Block Filler: Block filler, latex, interior/exterior, MPI #4

## INTERIOR PAINTING

- b. Intermediate Coat: Latex, interior, matching topcoat.
  - c. Topcoat: Latex, interior (MPI Gloss Level 4), MPI #43.
- D. Zinc Coated Metal (Wet Well)
- 1. High Gloss Alkyd Enamel: Two finish coats over primer.
    - a. Surface Preparation  
Clean free of oil and surface contaminants with a non-petroleum base solvent in accordance with SSPC-SP1 or as required by paint system manufacturer
    - b. Prime Coat  
Waterborne Galvanized Primer  
Carboline: Carbocrylic 3358 @ 2.0 – 3.0 mils DFT
    - c. First and Second Finish Coats  
High Gloss Waterborne Acrylic Enamel  
Carboline: Carbocrylic 3359 DTM @ 2.0 – 3.0 mils DFT per coat

END OF SECTION



**SECTION 09 9620  
HIGH PERFORMANCE COATING**

**PART 1 – GENERAL**

1.01 SCOPE:

The work specified in this section includes the surface preparation and field application of high-performance coating systems for the concrete and masonry surfaces in the secondary containment areas.

1.02 RELATED WORK SPECIFIED ELSEWHERE

- A. None

1.03 DEFINITIONS

- A. Coating Terms - ASTM D16
- B. DFT - Dry film thickness
- C. VOC – Volatile organic content

1.04 SYSTEM DESCRIPTION

- A. Products provided and installation by this Section are special coating materials requiring applicable special expertise in surface preparation, application and safety procedures, and should not be confused with conventional paint systems specified in Section 099100.
- B. Coating system shall consist of a moisture tolerant primer, 100% solids, spray applied, aromatic or aliphatic polyurethane, and broadcast aggregate on walking surfaces to provide slip resistance or other approved means.
- C. Work shall include surface preparation, paint application, inspection of painted surfaces and corrective action required, protection of adjacent surfaces, cleanup and associated work required for the proper painting of all surfaces to be painted. Surfaces to be painted are designated within the Coating Schedule.
- D. Perform coating application in strict accordance with the manufacturer's published recommendations and instructions.

1.05 QUALITY CONTROL

- A. A pre-job conference attended by the OWNER, the ENGINEER, the CONTRACTOR, the selected Coating CONTRACTOR, and Coating System Manufacturer shall be held at least 30 days prior to beginning of the coating system installation to ensure that all parties understand the written Specifications and manufacturer's requirements.
- B. Applicator Qualifications: Engage an experienced and manufacturer-certified applicator with a minimum of 5 years of documented experience installing high-performance coating system applications similar in material and extent to those indicated for Project and whose work has a record of successful in-service performance.

## HIGH PERFORMANCE COATING

- C. Source Limitations: Obtain primers and undercoat materials for each coating system from the same manufacturer as the finish coats.
- D. Benchmark Samples (Mockups):
  - 1. Provide a full-coat benchmark finish sample of each type of coating and substrate as required by the ENGINEER.
  - 2. Provide, when directed by ENGINEER, mock-ups of proper surface preparation, special surface preparation, and degree of surface cleanliness to be used as standards of acceptance for special coatings application.
  - 3. Apply each type special coating on minimum 100 square feet of typical area.
  - 4. Mock-up will be used to judge quality and finish of completed work. Application shall be observed by representative of coating system manufacturer to review and advise applicator on proper application procedures and techniques.
  - 5. Application of mock-up will be in accordance with specifications and manufacturer's recommendations for substrate.
  - 6. Leave approved mock-up in place as part of completed work if mock-up can be incorporated into work in acceptable manner.
  - 7. Final approval of colors will be from benchmark samples.
- E. Referenced Codes, Standards, and Other Documents:
  - 1. American Standards Testing Methods (ASTM)
    - a. ASTM D3359 Standard Test Methods for Measuring Adhesion by Tape Test
  - 2. Steel Structures Painting Council (SSPC)
    - b. Steel Structures Painting Council Manual, Volumes 1 and 2
    - c. SSPC-PA2-SSPC Method for Measurement of Dry Paint Thickness with Magnetic Gauges
    - d. SSPC-Vis 1 – Pictorial Surface Preparation Standards for Painting Steel Structures
    - e. SSPC Surface Preparation Standards:
      - a) SSPC-SP1                      Solvent Cleaning
      - b) SSPC-SP2                      Hand Tool Cleaning
      - c) SSPC-SP3                      Power Tool Cleaning
      - d) SSPC-SP6                      Commercial Blast Cleaning
      - e) SSPC-SP7                      Brush-Off Blast Cleaning
      - f) SSPC-SP10                      Near White Blast Cleaning
      - g) SSPC-SP13/NACE No. 6 Surface Preparation of Concrete

### 1.06 SUBMITTALS

#### A. General

## HIGH PERFORMANCE COATING

1. Comply with Section 01 3300.
- B. Product Data:
  1. Material List: A list of high performance coating systems (including appropriate primers and fillers) cross-referenced with the coatings schedule in this Section, identifying each product by name, number and generic type.
  2. Manufacturer's Information: Current Manufacturer's product data sheets with complete information on surface preparation, application, handling and storage requirements and VOC data showing compliance with current EPA AIM requirements.
  3. Submit manufacturer's material safety data sheets.
- C. Color Chart: Manufacturer's standard color chart showing range of colors available for each type of finish coat material indicated.
- D. Qualification Data: For firms and persons specified under Quality Assurance to demonstrate their capabilities and experience, include lists of five (5) completed projects with project names and addresses, names and addresses of architects and OWNERS, to verify experience and competency in the application of the specified high-performance coatings.
- E. Sample Warranty in accordance with Article 1.8, Warranty.

### 1.07 PRODUCT DELIVERY, STORAGE, AND HANDLING

- A. Deliver materials to Project site in manufacturer's original, unopened packages and containers bearing manufacturer's name and label with the following information:
  1. Name or title of material.
  2. Product description.
  3. Manufacturer
  4. Manufacturer's stock number and date of manufacture.
  5. Mixing and thinning instructions.
  6. Application instructions.
  7. Color name and number.
  8. Handling instructions and precautions.
  9. Material safety data sheet
- B. Store materials not in use in tightly covered containers in a well-ventilated area at a minimum ambient temperature of 50°F (10°C). Maintain containers used in storage in a clean condition, free of foreign materials and residue.
  1. Store material in protected and well ventilated area at temperature between 40 and 110°F. Protect materials from freezing. Keep storage area neat and orderly. Remove oily rags and waste daily. Take necessary measures to ensure that workers and work areas are protected from fire and health hazards resulting from handling, mixing, and applying coatings.

## HIGH PERFORMANCE COATING

2. Use only thinners manufactured and recommended by coating system manufacturer for each paint or coating used.
  3. Do not use materials beyond manufacturer's shelf life limits.
- C. Handling – Protect materials during handling and application to prevent damage or contamination.

### 1.08 PROJECT CONDITIONS

- A. Apply coatings only when temperature of surfaces to be coated and surrounding air temperatures fall within the range of acceptable temperatures shown on manufacturer's current product data sheets.
- B. Do not apply coatings in snow, rain, fog, or mist; when relative humidity exceeds 85 percent; at temperatures less than 5°F (3°C) above the dew point; or to damp or wet surfaces.
- C. Coordinate coatings application with other trades to assure adequate illumination, ventilation, and dust-free environment during application and curing of coatings.
- D. Protect adjoining surfaces not to be coated against damage or soiling.
- E. Maintain work area in a neat and orderly condition, removing empty containers, rags, and rubbish daily from the site and disposing of it properly and legally.
- F. Maintain a safe work environment in accordance with Federal, State, Local and project site regulations and guidelines.

### 1.09 EXTRA MATERIALS

- A. Furnish extra high-performance coating materials from the same production run as materials applied and in quantities described below. Package coating materials in unopened, factory-sealed containers for storage and identify with labels describing contents.
  1. Quantity: Furnish an additional 5 percent, but not less than 1 gal. (3.785 L) or 1 case, as appropriate, of each material and color applied.
  2. Furnish manufacturer's standard repair kit.

### 1.10 WARRANTY

- A. CONTRACTOR shall warrant that the specified coating system will prevent degradation of the surface on which the system is applied of more than one percent (1.0%) per year, and will not become unserviceable from either nonconforming materials or workmanship for a period of ten (10) years from the date of application. Defects shall include, but not be limited to, peeling, cracking, blistering, alligatoring, releasing from the substrate, chalking, or dusting.
- B. In the event the coating system does not provide the protection referred to in Paragraph A, the CONTRACTOR shall be obligated to provide and install coating materials for up to a period of ten (10) years as may be necessary to correct the affected area.

## HIGH PERFORMANCE COATING

- C. Submit a sample warranty in accordance with the requirements of Section 01 3300, Submittals, identifying all conditions, obligations, limitations, exclusions, and any other requirements necessary to provide the warranty specified herein, prior to the Pre-Job Conference.
- D. Submit in accordance with requirements of Section 01 7700, Closeout Procedures, warranties covering the items included under this Section.

### PART 2 - PRODUCTS

#### 2.01 MANUFACTURERS

- A. Products: Products manufactured by Carboline Company, 2150 Schuetz Road, St. Louis, MO 63146, phone: 314-644-1000 (toll-free 800-848-4645) are specified by name and number in order to establish a minimum standard of quality required for the Work.
- B. Manufacturers:
  - 1. Carboline Company
  - 2. Or ENGINEER approved equal

#### 2.02 COATINGS MATERIALS, GENERAL

- A. Material Compatibility: Provide primers, undercoats, and finish-coat materials that are compatible with one another and substrates indicated under conditions of service and application, as demonstrated by manufacturer based on testing and field experience.
- B. Obtain primers and intermediate coats for each coating system from the same manufacturer as the finish coats.
- C. Use only thinners recommended by the paint manufacturer. Follow manufacturer's mixing and thinning recommendations as noted per the product data sheet.
- D. Reference coatings system schedule for specific coatings defined for this project.
- E. Use paint materials suitable for the intended service and recommended by the paint manufacturer for the intended use.

### PART 3 - EXECUTION

#### 3.01 EXAMINATION

- A. Verify surfaces to be coated are dry, clean and ready to accept base coat in accordance with manufacturer's recommendations.
- B. Notify ENGINEER in writing of unacceptable conditions prior to commencing application.
- C. Do not paint over dirt, rust, scale, grease, moisture, scuffed surfaces, or conditions otherwise detrimental to formation of a durable paint film.
- D. Do not begin work until unsatisfactory conditions have been corrected.

## HIGH PERFORMANCE COATING

- E. Examine substrates and conditions under which high-performance coatings will be applied, for compliance with coating application requirements.

### 3.02 GENERAL PREPARATION

- A. Protect surrounding and adjacent surfaces in manner recommended by coating manufacturer.
- B. Scrape or grind protrusions flush with surface.
- C. Dislodge dirt, mortar spatter and other dry materials by scraping or brushing. Remove dust and loose material by brushing, sweeping, vacuuming and blowing with high pressure air.
- D. Remove oil, wax and grease by scraping off heavy deposits and cleaning with mineral spirits or hot trisodium phosphate solution followed by water rinse.
- E. Remove plates, machined surfaces, and similar items already in place that are not to be coated. If removal is impractical or impossible because of size or weight of item, provide surface-applied protection before surface preparation and coating.
- F. Concrete shall be fully cured before surface preparation or coating application. Minimum cure time is 28 days for typical Portland Cement ASTM Type I, or 7 days for ASTM Type III – High-Early Strength.

### 3.03 SURFACE PREPARATION

- A. Clean and prepare surfaces to be coated according to manufacturer's written instructions for each substrate condition and as specified.
- B. Concrete: The entire surface area shall be abrasive blasted to meet the following requirements.
  - 1. Conform to current Society for Protective Coatings (SSPC) Specifications for concrete surface preparation SSPC-SP13/NACE No.6.
  - 2. Concrete shall be surface prepared in accordance with SSPC cleaning procedures recommended for particular coating system to be used and shown in the coating schedule.
- C. If present, all leaks and infiltrations shall be repaired and eliminated as directed by ENGINEER.

### 3.04 APPLICATION

- A. Mix and apply coating materials using heated, plural component spray applicator, in accordance with manufacturer's directions. Apply at minimum specified rate of coverage by method recommended by manufacturer.
- B. Apply coating materials to scheduled surfaces in accordance with manufacturer's recommendations.
  - 1. Rate of application (dry film thickness) shall not exceed manufacturer's recommendations.

## HIGH PERFORMANCE COATING

2. Stir all material as required for application of materials. Do not stir surface film into the material. Remove film and, if necessary, strain coating material before using.
  3. Comply with manufacturer's recommendations for drying or curing time between coats.
  4. Finished surfaces shall be uniform in finish and color.
- C. Cut in edges clean and sharp, without overlapping, where work joins other materials or colors.
- D. Allow each coat to dry thoroughly before recoating.
- E. Make finish coats smooth, uniform in texture and color, and free of brush marks, laps, runs, dry spray, overspray and skipped or missed areas.
- F. Use only the type of thinners approved by manufacturer and only within recommended limits.

### 3.05 FIELD QUALITY CONTROL

- A. Manufacturer's representative shall be available to visit the job site occasionally addressing any technical questions or concerns and to verify that materials are being applied in accordance with requirements of this Specification and with manufacturer's printed instructions.
- B. Surface preparation must be accepted before proceeding with coating application.
- C. Request acceptance of each coat before applying succeeding coats.
- D. Initiate and maintain for duration of Project field quality control program using certified calibration and testing devices to ensure conformance with application requirements.
- E. Retain all paint cans, with labels intact, and lids on site until authorized by ENGINEER.

### 3.06 TOUCH UP AND REPAIR

- A. Touch-up and repair damaged or otherwise unacceptable work.

### 3.07 CLEANING

- A. Remove rubbish, empty cans, rags, and other discarded materials from Project site.
1. After completing coating application, clean spattered surfaces. Remove spattered coatings by washing, scraping, or other methods. Do not scratch or damage adjacent finished surfaces.

### 3.08 PROTECTION OF COATING SYSTEMS

- A. Protect work of other trades, whether being coated or not, against damage from coating operation. Correct damage by cleaning, repairing, replacing, and recoating, as approved by ENGINEER, and leave in an undamaged condition.

## HIGH PERFORMANCE COATING

- B. Provide "Wet Paint" signs to protect newly coated finishes. After completing coating operations, remove temporary protective wrappings provided by others to protect their work.
- C. At completion of construction activities of other trades, touch up and restore damaged or defaced coated surfaces, at no additional cost to the OWNER.

### 3.09 COATING SCHEDULE

- A. HIGH PERFORMANCE COATING SYSTEMS – All concrete and masonry surfaces within the oxidizer containment area , including slabs and walls.
  - 1. Interior, new concrete subject to water immersion
    - a. System Type: Vinyl Ester
    - b. Surface preparation: SSPC-SP 13/NACE No. 6
    - c. Resurfacing Compound – Semstone 800 PM – as needed to fill bugholes, voids, cracks, etc
    - d. 1<sup>st</sup> coat: (vinyl ester) Carboline Semstone 800 @ 8.0 to 10.0 Mils DFT
    - e. 2<sup>nd</sup> coat: (vinyl ester) Carboline Semstone 870 @ 25.0 to 30.0 DFT, Color: Light Gray
    - f. For horizontal surfaces, apply aluminum oxide and then add an additional coat of Carboline Semstone 870 @ 8.0 to 10.0 Mils DFT.

END OF SECTION



**DIVISION 23**  
**VENTILATION**

**THIS PAGE LEFT BLANK INTENTIONALLY**

# Section 23 0900 HVAC CONTROL SYSTEMS

## **PART 1      GENERAL**

### **1.01 Summary**

- A. Section Includes: Control Systems Work as indicated on Drawings and by requirements of this Section.
  - 1. Control sequences are specified in this Section.
- B. Related Documents: Drawings and general provisions of Contract, including General and Supplementary Conditions and Division 1 Specification Sections, apply to Work of this Section.
- C. Refer to Division 26 Sections for the following Work; not Work of this Section:
  - 1. Power supply wiring from power source to power connection on controls and/or unit control panels. Include starters, disconnects, and required electrical devices, except where specified as furnished or factory installed by manufacturer.
  - 2. Interlock wiring between electrically operated equipment units and between equipment and field-installed control devices.
    - a. Interlock wiring specified as factory installed, is Work of this Section.

### **1.02 System Description**

- 1. Temperature control sequences of operation are indicated on Drawings.

### **1.03 Submittals**

- A. Shop Drawings: Submit in accordance with Section 01 3300, Submittal Procedures, Shop Drawings covering the items included under this Section. Shop Drawing submittals shall include:
  - 1. Manufacturer's technical product data for each control device furnished, indicating dimensions, capacities, performance and electrical characteristics, and material finishes. Include installation and start-up instructions.
  - 2. Shop Drawings for each control system containing the following information:
    - a. Schematic flow diagram of system showing fans, pumps, coils, dampers, valves, and control devices.
    - b. Label each control device with setting or adjustable range of control.
    - c. Indicate all required electrical wiring. Clearly differentiate between portions of wiring that are factory installed and portions to be field installed.
    - d. Provide details of faces of control panels including controls, instruments, and labeling.
    - e. Complete written verbal description of sequence of operation for each system.
    - f. Complete description of control panel construction.

- B. Operation and Maintenance Manuals: Submit in accordance with requirements of Section 01 6000, Product Requirements, operation and maintenance manuals for items included under this Section.

#### **1.04 Quality Assurance**

- A. Manufacturer's Qualifications: Firms regularly engaged in manufacture of control equipment, of types and sizes required, and whose products have been in satisfactory use in similar service for not less than 5 years.
- B. Codes and Standards:
  - 1. Electrical Standards: Provide electrical components of control systems which have been UL listed and labeled, and comply with NEMA standards.
  - 2. NEMA Compliance: Comply with NEMA standards pertaining to components and devices for control systems.
  - 3. NFPA Compliance: Comply with NFPA 90A, "Standard for the Installation of Air Conditioning and Ventilating Systems," where applicable to controls and control sequences.

#### **1.05 Service and Warranty**

- A. Under Temperature Control all thermostats, control valves, motors, and other equipment provided under this Contract shall be adjusted. The equipment shall be placed in complete operating condition subject to the approval of ENGINEER, and the operating personnel shall be instructed in the operation of the control system. The control system as shown on Drawings and specified herein shall be guaranteed free from defects in workmanship and material under normal use and service for a period of 1 year after acceptance of ENGINEER. Any equipment described herein proven to be defective in workmanship or material during the warranty period shall be adjusted, repaired, or replaced by the manufacturer at no charge to OWNER.

#### **1.06 Delivery, Storage, and Handling**

- A. Provide factory shipping cartons for each piece of equipment and control device. Maintain cartons while shipping, storage, and handling as required to prevent equipment damage and to eliminate dirt and moisture from equipment. Store equipment and materials inside and protect from weather.

### **PART 2      PRODUCTS**

#### **2.01 Manufacturers**

- A. Subject to compliance with specified requirements, manufacturers offering products which may be incorporated in Work include:
  - 1. Control Systems:
    - a. Honeywell, Inc.
    - b. Johnson Controls, Inc.
    - c. Robertshaw Controls Co.
    - d. Barber-Colman Co.
  - 2. Line Voltage Thermostat:
    - a. Honeywell, Model T6051A.

- b. Robertshaw.
- 3. Smoke Detectors:
  - a. Honeywell.
  - b. Robertshaw.
- 4. Automatic Dampers:
  - a. Greenheck,
  - b. Approved equal.

## **2.02 Materials and Equipment**

Provide control products in sizes and capacities indicated, consisting of dampers, thermostats, and other components as required for complete installation. Except as otherwise indicated, provide manufacturer's standard materials and components as published in their product information; designed and constructed as recommended by manufacturer, and as required for application indicated.

- A. Temperature Control Equipment:
  - 1. Electric Control Systems:
    - a. Line Voltage Thermostat: Thermostats shall be line voltage bimetal type instruments and rated for 16 amps at 120V. Thermostats shall be provided with Fan-Off-Auto subbase and shall have a setpoint range of 46-84 degrees F and a fixed differential of 1 degree F.
  - 2. General Control Systems:
    - a. Automatic Dampers:
      - 1) Frame: 13 gauge galvanized steel minimum.
      - 2) Blades: 16 gauge galvanized steel minimum; 8-inch width maximum.
      - 3) Bearings: Stainless steel, bronze, plastic, or nylon.
      - 4) Blade Seals: Synthetic elastomeric or neoprene, mechanically attached.
      - 5) Jamb Seals: Stainless steel flexible metal.
      - 6) Linkage: Face mounted.
      - 7) Leakage: 8 cfm per square foot maximum using a 48-inch by 48-inch damper with a 1-inch differential static pressure tested per AMCA Standard 500.
      - 8) Jackshaft: Minimum 3/4-inch galvanized steel.
    - b. Operators: Provide operators for automatic dampers. Operators shall be selected to provide the torque necessary for proper operation and sealing. Multiple operators shall be installed if necessary for proper operation.
      - 1) Electric operators shall be sealed motor units with oil-immersed gear train. Motor covers shall be removable without disturbing the conduit or field wiring. Modulating and 2-position motor operators shall be spring return.

## **PART 3 EXECUTION**

### **3.01 Acceptable Installers**

- A. Installer's Qualifications: Firms specializing and experienced in control system installations for not less than 5 years.

### **3.02 Inspection**

- A. Examine areas and conditions under which control systems are to be installed. Do not proceed with Work until unsatisfactory conditions have been corrected in manner acceptable to Installer.

### **3.03 Installation of Control Systems**

- A. Install systems and materials in accordance with manufacturer's instructions, roughing-in drawings, and details shown on Drawings. All piping shall be concealed except in mechanical rooms or areas where other piping is exposed.

### **3.04 Adjusting and Cleaning**

- A. Start-up, test, and adjust control systems in presence of manufacturer's authorized representative. Demonstrate compliance with requirements. Replace damaged or malfunctioning controls and equipment.
- B. Clean factory-finished surfaces. Repair any marred or scratched surfaces with manufacturer's touch-up paint.
- C. Final Adjustment: After completion of installation, adjust thermostats, control valves, motors, and similar equipment provided as Work of this Section.
  - 1. Final adjustment shall be performed by specially trained personnel in direct employ of manufacturer of primary temperature control system.

### **3.05 Demonstration**

- A. OWNER's Instructions: Provide services of manufacturer's technical representative for one 8-hour day to instruct OWNER's personnel in operation and maintenance of control systems.
  - 1. Schedule instruction with OWNER; provide at least 7-day notice to CONTRACTOR and ENGINEER of training date.

**END OF SECTION**

**DIVISION 26**  
**ELECTRICAL**

**THIS PAGE LEFT BLANK INTENTIONALLY**



**SECTION 26 05 00  
GENERAL REQUIREMENTS**

**PART 1 GENERAL**

1.1 GENERAL REQUIREMENTS

A. CONTRACTOR:

1. Furnish all labor, materials, equipment, and devices necessary for the complete electrical system as shown on the drawings and herein specified. It is the responsibility of the CONTRACTOR that the system is balanced, phased-out, tested, adjusted, fully protected and coordinated.
2. The work shall include but not be limited to the following:
  - a. Temporary Electric
  - b. Concrete Work for Electrical
  - c. Identification
  - d. Wire
  - e. Boxes
  - f. Wiring Devices
  - g. Safety Disconnect Switches
  - h. Grounding
  - i. Switch board and circuit breaker line-ups.
  - j. Enclosed Circuit Breakers
  - k. Lighting
  - l. Instrumentation
  - m. PLC Programming.
3. Furnish and install all components of the listed systems as specified and indicated on the drawings.

1.2 PROTECTION

- A. The CONTRACTOR shall take necessary precautions to protect their materials and equipment from damage. After completion of their work, the CONTRACTOR shall clean all electrical equipment and enclosures inside and out.
- B. All materials delivered to the job site shall be packaged by the manufacturer to prevent damage during shipment, handling and storage prior to installation.
- C. All materials shall be stored in clean dry area. Materials stored on the ground with plastic covers to shed the elements will not be acceptable. Conduit may be stored outdoors with appropriate provisions to keep it clean & dry.
- D. Storage or installation of electrical equipment inside the building prior to completion of a watertight roof is not acceptable. Conduit may be installed if all open ends are sealed at the end of each day's work.

1.3 SUBMITTALS

- A. The CONTRACTOR shall prepare and submit shop drawings for the work under this Section.

## GENERAL REQUIREMENTS

- B. Shop drawings shall consist of manufacturer's data, catalog sheets, fabrication drawings, etc. as required to completely describe the equipment or material.
- C. Manufacturer's data shall include ratings, dimensions, model numbers, options, etc., to allow for a review to determine conformance with the contract documents.
- D. Submit shop drawings for all electrical equipment and materials furnished, including basic items such as wire, conduit, boxes, etc.
- E. Prior to forwarding submittals for review, the CONTRACTOR shall verify that the equipment proposed interfaces properly with all associated devices such as control panels, motor control center, electric power source, etc.

### 1.4 JOB SITE DOCUMENTS

- A. The CONTRACTOR shall keep up-to-date at a central job site location a complete set of prints, specifications, shop drawings, etc. including all changes and modifications. These documents shall be available on the job site for use by the CONTRACTOR's personnel and for examination by the OWNER/ENGINEER. The Contract Drawings shall be corrected daily to show every change from the original plans and specifications. This set of drawings shall be used as reference in preparation of the final as-built prints. These as-built prints shall be submitted to the ENGINEER at the completion of the work.

### 1.5 QUALITY ASSURANCE

- A. All material shall be new and shall conform to the standards of the Underwriter's Laboratories, Inc., in any case where such a standard has been established. In case of assemblies, the components shall be Underwriter's Laboratories, Inc. listed for use as an integral part. In addition all materials shall conform to applicable NEMA, ANSI, and Federal Specifications requirements.
- B. The entire installation shall be made in conformance with the requirements of the latest publications of:
  - 1. National Fire Protection Association (NFPA)
  - 2. National Electrical Code (NEC)
  - 3. National Electrical Safety Code (NESC)
  - 4. National Electric Manufacturers Association (NEMA)
  - 5. Institute of Electrical and Electronic Engineers (IEEE)
  - 6. Occupational Safety and Health Administration (OSHA)
  - 7. Applicable state and local codes and ordinances.
- C. The CONTRACTOR shall coordinate with the local inspection authority, throughout the course of the construction, to make sure that all installation methods and materials meet the inspector's requirements.
- D. After completion of all work, the CONTRACTOR shall have the installation inspected and certified by the local inspection authority. Any rework necessary to obtain approval shall be at the expense of the CONTRACTOR.

## GENERAL REQUIREMENTS

- E. The CONTRACTOR shall pay all charges and fees associated with inspection and certification of the electrical work.

### 1.6 SLEEVE OPENINGS, CUTTING AND PATCHING

- A. The CONTRACTOR shall provide all sleeve holes and other openings through any part of the various buildings and structures.
- B. The CONTRACTOR shall be responsible for all cutting and patching required to accommodate their work.
- C. Structural members shall not be cut without consent from the ENGINEER. Patching shall match the original conditions.

### 1.7 SEALING OPENINGS

- A. All sleeve holes or other openings in outside walls shall be sealed to prevent any water seepage through these openings. All locations where wall sleeves pass through exterior structure walls shall have cast iron or steel sleeves installed. The sleeves shall be complete with water stop.
- B. Where sleeve openings enter spaces through walls at a location below grade, the space between the conduit and the wall opening shall be sealed with a mechanical type seal. The mechanical seal shall be a modular type consisting of synthetic rubber link shaped to continuously fill the annular space between the pipe and the wall opening. The closure shall be water tight when the bolts are tightened. The seal shall be "Link Seal" manufactured by Thunderline Corporation of Wayne, Michigan or equal.
- C. All sleeves or other openings penetrating the roof shall be suitably flashed and sealed in accordance with the requirements of the Section on Roofing.

### 1.8 RECORD DOCUMENTS

- A. At the completion of the project, all operating instructions, parts lists, shop drawings and maintenance instructions for material and equipment furnished by the CONTRACTOR shall be indexed and neatly bound into a set of record documents.
- B. Initially, a single set of record documents shall be submitted to the ENGINEER for review and approval. After the review set has been returned to the CONTRACTOR with comments, three (3) complete revised sets of record documents shall be turned over to the OWNER.

### 1.9 GUARANTEE

- A. The CONTRACTOR shall guarantee all equipment and material furnished under this specification for a period of one (1) year after the date of final acceptance. Equipment manufacturer's warranties shall be passed on to the OWNER. Should any defects appear within this period, the CONTRACTOR shall repair or replace

## GENERAL REQUIREMENTS

said defects or any damage to building or contents caused by defective workmanship or equipment, and shall make immediate adjustments at no cost to the OWNER or ENGINEER.

- B. The CONTRACTOR shall furnish maintenance and call-back service for the equipment provided by him for a period of one (1) year after the work is substantially complete. This service shall include regular examinations of the installation by competent and trained employees of the CONTRACTOR, and shall include all necessary adjustments, cleaning, supplies and parts to keep the equipment in good operation, except parts made necessary by misuse or accidents not caused by the CONTRACTOR.

### 1.10 EQUIPMENT LOCATIONS

- A. All receptacle outlets, wall switches and associated conduit shall be concealed in the wall construction, however, other equipment and wiring may be surface mounted. All equipment specifically designed for surface mounting shall have surface conduit.
- B. Equipment locations shown on the drawings may change due to interference problems, equipment design, etc. The CONTRACTOR shall verify the locations of devices and equipment installed by other contractors prior to final rough-in. Adjust conduit layouts as required to compensate for changes.

### 1.11 ACCESS TO EQUIPMENT

- A. All devices and equipment shall be located to allow easy access for maintenance and repair. Access shall be from the floor without the use of ladders.
- B. The equipment locations shall be reviewed with the work of other trades and contractors to verify that adequate working space will remain after all equipment is installed. All electrical equipment shall have NEC required access space.
- C. Where devices and equipment are installed in non-accessible ceilings or wall construction, flush mounted access panels shall be furnished and installed by the CONTRACTOR.
- D. Where equipment locations shown on the drawings deny adequate access, the CONTRACTOR shall notify the ENGINEER to allow for review and adjustment of the location.

### 1.12 PAINTING

- A. All unpainted equipment and equipment which has its finish damaged during the course of construction shall be painted.
- B. Enclosures made of PVC or stainless steel do not require paint.

## GENERAL REQUIREMENTS

- C. Where conduit is installed or changed after the painting in an area is completed, the CONTRACTOR shall be responsible for arranging and paying for the electrical materials to be painted.

### 1.13 PROJECT CONDITIONS

- A. Existing Utilities: Do not interrupt utilities serving facilities occupied by OWNER or others unless permitted under the following conditions and then only after arranging temporary utility services according to requirements indicated:
  - 1. See Section 01 3523 Job Conditions regarding the interruption or shut down of utilities serving the facility.
  - 2. Do not proceed with utility interruptions without ENGINEER's written permission.

### 1.14 TESTING

- A. When electrical service conductors and branch feeders are installed, the voltage and phase relationships shall be verified prior to energizing loads.
- B. Test all motors for proper phase rotation prior to energizing.
- C. Test all Industrial and computer networks.
- D. See additional requirements noted in the various Sections.

### 1.15 DEMONSTRATION

- A. The CONTRACTOR shall demonstrate to the OWNER, or their representative, the proper use, operation and maintenance of all equipment furnished and installed under any of the Electrical Sections.
- B. The demonstration shall include written materials, diagrams, hands-on instruction and other aids.
- C. The demonstration shall pay particular attention to all safety related aspects.
- D. See additional requirements in appropriate Sections.

### 1.16 SEQUENCE OF WORK

- A. The CONTRACTOR shall review the overall construction requirements and schedule their work to coordinate with other trades.

### 1.17 COORDINATION

- A. These specifications and accompanying plans are mutually explanatory and anything required by one but not by the other shall be considered as required by both. Where the requirements differ or are contradictory between different specification sections, between different drawings or between drawings and

## GENERAL REQUIREMENTS

specifications, the more restrictive (larger size, greater rating, more options, etc.) shall apply.

- B. Drawings indicate diagrammatically the desired arrangement and the approximate location of principal conduit, wiring, apparatus and equipment. Certain runs of conduit and locations of equipment are shown distorted on drawings to avoid confusion. Measurements, dimensions, equipment space requirements, etc., shall be verified on the job site by the CONTRACTOR. The entire installation shall be made in a manner to avoid obstructions, to preserve headroom, keep openings clear and to overcome local difficulties and interference with structural conditions and with other trades.
- C. If installed work interferes with the work of others, it shall be corrected.
- D. Pre-occupation of a space by a CONTRACTOR does not give the CONTRACTOR the right to the space. All work must be coordinated with other contractors and trades in advance of installation.

### 1.18 EQUIPMENT INTERFACE COORDINATION

- A. The plans and schematic drawings show the required control connections and interfaces between the various control panels and devices, however, during the construction process some products may be substituted by the General/Mechanical, the manufacturer may change their product, etc.
- B. The CONTRACTOR shall be responsible for coordinating with the review all submittals to verify that they conform to the electrical requirements of other devices to which they are connected. Where discrepancies are noted, the CONTRACTOR shall:
  - 1. Where the equipment specified will not work properly, inform the ENGINEER prior to final shop drawing review to allow changes to make the devices compatible, OR
  - 2. Provide necessary materials and equipment to interface the incompatible devices. Added materials will require the approval of the ENGINEER. All costs for added materials and labor shall be by the CONTRACTOR.
  - 3. After equipment and materials have arrived on the job site, the CONTRACTOR shall be responsible for all materials and work required for proper interface and operation.

### 1.19 CONCRETE WORK FOR ELECTRICAL

- A. All concrete work required by the drawings including but not limited to:
  - 1. Housekeeping pads under the switch gear and motor starters and other floor mounted electrical equipment.
- B. All concrete work shall comply with applicable sections of the specifications.

## GENERAL REQUIREMENTS

### 1.20 IDENTIFICATION

- A. Each panelboard, disconnect switch, starter, control station, control panel, instrument, transmitter, etc. shall be labeled to indicate the name of the equipment controlled, load served, designation letter, voltage and phase, etc.
- B. Tags and labels required in paragraph "A" above shall be engraved laminated phenolic plastic type with 1/4" high letters. The tags and labels shall be permanently attached to the various devices. (i.e. rivets, screws, etc.)
- C. All equipment shall be appropriately labeled to warn of potential safety hazards.
- D. Each automatic electric motor or other automated electrical device with moving parts shall have a sign warning of automatic remote starting. Emed Co., Inc. metal backed plastic sign, 7" x 10", #5250 or equal.
- E. See specific Sections for additional identification requirements.
- F. The CONTRACTOR shall remove all temporary facilities upon completion of the project.

### **PART 2 Products**

#### 2.1 GENERAL

- A. See individual specification Sections for product information.

### **PART 3 Execution**

#### 3.1 INSTALLATION STANDARDS

- A. The installation of all materials and equipment for the electrical work shall comply with the "National Electrical Contractor's Association Standard of Construction". All work shall be completed in a neat, thorough, clean and workmanlike manner.
- B. Installation of materials shall comply with the manufacturer's recommendations.
- C. The CONTRACTOR shall supply all auxiliary equipment, frames, supports, access panels, and other devices required for proper installation and operation of equipment furnished and installed by him.

END OF SECTION

## GENERAL REQUIREMENTS

THIS PAGE INTENTIONALLY LEFT BLANK



**SECTION 26 05 19**  
**ELECTRICAL CONDUCTORS AND CABLES**

**PART 1 GENERAL**

1.1 GENERAL REQUIREMENTS

- A. The CONTRACTOR is to provide all wiring and cables as shown on the drawings and as required for proper installation of the various electrical systems (service feeders, power feeders, branch circuits, lighting, control, signal, etc.).
- B. Provide electrical wiring as required to serve electrical equipment specified and furnished under other sections of the specifications.
- C. Determine wire numbers for each control, signal, instrumentation, and communication conductor, complete the Control cable schedules and identify each conductor and cable.
- D. Provide all electrical wiring for devices, feeders, etc. provided by this contract.

1.2 TESTING

- A. All wiring size #8 AWG and larger shall be tested for shorts, grounds, and faulty insulation. The tests shall be performed after the wire is pulled and before devices and equipment are connected to the wire. The wiring shall be tested with a "Megger" type insulation-testing device with 1000-volt test voltage or as recommended by the wire manufacturer.
- B. All other wires shall be tested for continuity and ground with a hand held tester.
- C. All wires or cables that fail or show a weakness, indicating damage, shall be replaced.

**PART 2 PRODUCTS**

2.1 WIRE

- A. All wire and cable shall have copper (98% conductivity) conductors and shall be installed in conduit.
- B. Insulation for power wiring size #10 and smaller diameter shall be THHN rated for 600 volt operation wet or dry at 75 degrees
- C. No branch circuit wiring shall be smaller than #12 AWG, except control wiring, which may be smaller as required and detailed in the drawings.
- D. All wire including control wiring #14 AWG shall have stranded conductors. Telephone wiring shall be #24 AWG with solid conductors or wire specifically detailed in the drawings.
- E. Control cable shall be general purpose, NEC type TC with a 600 volt, 90 degree C. insulation rating and stranded copper conductors. Each wire shall be color-

## ELECTRICAL CONDUCTORS AND CABLES

coded with PVC over polyethylene insulation and the entire cable shall be covered with a PVC jacket. Where multi-conductor cable is shown on the drawings, the cable shall run from device terminals to the appropriate control panel terminals without splices. Separate or individual conductors shall not be substituted for multi-conductor cables.

- F. Wiring for 4-20 mA-DC instrumentation signals shall have 2 stranded tinned copper #18 AWG conductors with foil shield, drain and overall jacket. Multiple signal "snake" cables are acceptable where installation is feasible.
- G. Special wiring and cables for instrumentation shall be as indicated under the appropriate Section or on the drawings. Wire type shall be as specified by the instrument manufacturer of the particular field device.
- H. Acceptable manufacturer's or equal:
  - 1. American Wire & Cable
  - 2. Colonial Wire & Cable
  - 3. Triangle
  - 4. Cerrowire
  - 5. Belden
  - 6. Rome Wire & Cable

### 2.2 TERMINATIONS

- A. Terminations, taps and splices shall be made with bolted or mechanical compression connectors.
- B. Insulated compression type connectors shall be used on 120 volt power wire size #12 AWG. Spring compression type connectors shall not be used on stranded wire.
- C. Connectors shall have an insulation covering with a thickness of 1.5 times the conductor insulation thickness. The insulation covering may be part of the assembly or an applied heat shrinkable material.
- D. Acceptable manufacturer's or equal:
  - 1. Burndy
  - 2. Thomas & Betts
  - 3. Ideal
  - 4. 3M Company
  - 5. Square D
  - 6. Berk-Tek

### 2.3 WIRE MARKERS

- A. Wire markers for power feeders and branch circuit conductors shall be Brady B-500 adhesive backed vinyl cloth type or equal.
- B. Wire markers for control wiring shall be Brady B-321 heat shrinkable polyolefin type or equal.

## ELECTRICAL CONDUCTORS AND CABLES

### PART 3 EXECUTION

#### 3.1 WIRE

- A. All wiring shall be installed in conduit.
- B. Multiple circuits are acceptable in single conduits provided they meet the following criteria:
  - 1. Allowable conductors per conduit as specified by the National Electric Code Fill Tables for Conductors and Fixture Wires of the Same Size.
  - 2. Conductors must be of the same "Signal Type" as specified in the Cabling Schedules on the drawings.
  - 3. Multi-circuit 4-20mA signal "snake" cables are permissible where installation merits such types.
- C. All feeder and branch circuit wires shall be color coded as follows:

Wire	277/480V, 3PH-4W	120/208V. 3PH-4W
Phase A	Brown	Black
Phase B	Orange	Red
Phase C	Yellow	Blue
Neutral	White/Grey	White
Ground	Green	Green/White

- D. Wire sizes #8 AWG and larger may be identified by tags or labels on each end instead of insulation color. Tags or labels to have the same color coding.
- E. Cable schedules for control and instrumentation cabling shown as individual raceway runs may be combined to facilitate installation for "like" electrical characteristics.
- F. Pulling lubricant shall be a type recommended by the wire or cable manufacturer.
- G. No conductors shall be pulled until conduits are free from moisture and contaminates.

#### 3.2 WIRE AND CABLE MARKERS

- A. All power feeders and branch circuit wires shall be tagged in cabinets, junction boxes, panel boards, etc. with permanent labels attached to the wire within 6 inches of the termination point. Labels shall be legible and shall not be removed, cut-off, etc.
- B. All control, signal and instrumentation wires shall be identified on each end using the wire numbers derived from the line numbers on the schematic drawings or from the numbering system in the associated control panels.
  - 1. Numbers shall be typed on the heat shrinkable labels with permanent ink. Hand lettered labels are not acceptable.
  - 2. Labels shall be installed approximately 1/2" from the termination point and shrunk to a tight fit on the wire with a heat gun.

## ELECTRICAL CONDUCTORS AND CABLES

3. Labels shall be oriented to so that they are right side up and readable after the wire is connected to the terminal block.
- C. All cables shall be identified in all pull boxes, terminal boxes, manholes, control cabinets, control panels, etc. with permanent labels attached to the cable.

### 3.3 TERMINATIONS

- A. All control and instrumentation wire shall terminate with compression type, PVC or nylon insulated pin type lugs. Pin type lugs shall be suitable for use with box type connectors on terminal strips in control cabinets, terminal boxes, starters, control panels or device terminals. Control wire may be installed without compression type termination lugs on a temporary basis for checkout prior to final wire marking.
- B. Control and instrumentation wire shall not be spliced. All control wires shall terminate on terminal blocks or at device terminals.
- C. Where control and power wiring are in the same enclosure, the control wiring shall be bundled and separated to the maximum extent possible from the power wiring. Where 4-20 mA-DC circuits (shielded cable) cannot be separated from power wiring, all device manufacturer wiring and installation instructions shall be administered.
- D. Each terminal shall be identified to match the identification of the wire attached. The terminal identification shall be in addition to and separate from the wire identification. Terminal identification shall be completed with typed labels and shall not be hand labeled.

### 3.4 FIELD QUALITY CONTROL

- A. All voice and data cables will be tested by a qualified technician for linemap and any other mis-wires using an Ideal Linkmaster Pro or equivalent tester.
- B. All Test requirements will be in compliance for Category 6 under the TIA/EIA – 568B standard.

END OF SECTION

**SECTION 26 27 28**  
**LOCAL SAFETY DISCONNECT SWITCHES**

**PART 1 GENERAL**

1.1 GENERAL REQUIREMENTS

- A. CONTRACTOR to:
  - 1. Provide all safety disconnect switches for all motors, appliances and other electrical equipment as shown in the drawings.
  - 2. Provide all fuses for safety disconnect switches, combination fusible starters, etc. where required.
  - 3. Review the drawings to verify location size of equipment requiring a safety disconnect switch.

**PART 2 PRODUCTS**

2.1 SAFETY DISCONNECT SWITCH

- A. All safety disconnect switches shall be heavy duty, industrial type rated at 480 volts and fusible unless noted. Fused switches shall have rejection feature for Class R fuses.
- B. Safety switches shall be three (3) pole units with a solid neutral and amp or horsepower rating based on the load served or as shown on the drawings.
- C. Outdoor switch enclosures shall be NEMA 4X stainless steel unless noted otherwise on the drawings. Switches marked on the drawings as "S.S." shall be stainless steel.
- D. Switches listed in hazardous locations shall be NEMA 4X stainless steel unless otherwise noted on the drawings.
- E. All switches shall have front cover mounted metal nameplate containing switch type, catalog number and HP rating; handle whose position is easily recognizable; non-teasible, positive, quick-make, quick-break mechanism; and switch assembly plus operating handle as an integral part of the enclosure base.
- F. Switches to be installed exposed outside in non-secure areas shall be padlockable in both the ON and OFF positions. All other switches shall be padlockable in the OFF position.
- G. All safety switches installed in outdoor locations which are not enclosed inside a fence shall be furnished with a brass (outdoor type) padlock with common key.
- H. Switches shall meet NEMA specifications KSI-1990.
- I. Acceptable manufacturer's or equal:
  - 1. General Electric for NEMA 1 applications
  - 2. Or approved equal.

## **LOCAL SAFETY DISCONNECT SWITCHES**

### **2.2 FUSES**

- A. Fuses From 0 To 600 Amp Rating Shall Be Combination Dual Element Time Delay And Current Limiting Type, U.L. Class RK-1.
- B. Fuses shall be manufactured by Bussman, Gould, or equal.

### **2.3 HAZARDOUS LOCATION DISCONNECTS**

- A. Surface mountable
- B. Copper free Aluminum
- C. "Akron Electric CXI-Manual" motor starter or equal

## **PART 3 EXECUTION**

### **3.1 INSTALLATION**

- A. Safety disconnect switches shall be securely attached to the building or other structure and shall not depend on conduits for support.

### **3.2 FUSES**

- A. Furnish and install fuses in all devices where fuses are indicated or required.
- B. Provide 1 spare fuse for each rating and type installed in the various items of electrical equipment furnished by the CONTRACTOR. Turn the spare fuses over to the OWNER at the completion of the project.
- C. Permanently attach a label at each device which requires fuses. The label to indicate the proper size and type of fuse required for the device. The label shall be located on the inside cover of switches, motor starters, etc. Labels shall be plastic stick-on type with hand printed notations.

END OF SECTION

**SECTION 26 50 00  
LIGHTING**

**PART 1 GENERAL**

1.1 GENERAL REQUIREMENTS

- A. CONTRACTOR to:
1. Provide all lighting fixtures (interior and exterior) and lamps as shown on the drawings.
  2. Provide the installation, wiring, and testing of all lighting.

1.2 SUBSTITUTIONS

- A. Where the CONTRACTOR proposes to utilize lighting fixtures other than those specified on the drawings, he shall provide all of the following:
1. An item by item check off of the physical construction features of the substitute versus the specified unit as follows:
    - a. Material type and thickness.
    - b. Dimensions (depth of troffers, depth of downlights, etc.).
    - c. Reflectances.
    - d. Finish (interior and exterior).
    - e. Lens material, thickness and pattern.
    - f. Ballast.
  2. An item by item comparison of the photometrics of the substitute versus the specified unit as follows:
    - a. Total efficiency.
    - b. Coefficient of utilization at RCR 1 through 5 and reflectance of C-50%, W-50%, F-20%.
    - c. Space to mounting height ratio.
  3. Substitute fixtures submitted for approval without the above noted information will be returned without review and marked resubmit.
  4. Where substitute fixtures have significant deficiencies in any area, they will be rejected.
  5. For exterior pole mounted lighting fixtures, additional information shall be provided:
    - a. EPA and pole data for 100 MPH wind speed.

**PART 2 PRODUCTS**

2.1 LIGHTING FIXTURES

- A. Lighting fixtures shall be as shown on the drawings.
- B. All fluorescent ballasts shall be CBM-ETL certified Class P and shall be energy saving electronic type with maximum THD of 10%.
- C. All battery powered emergency and exit fixtures shall have the following minimum features:
1. A 3-year warranty on all components except lamps and fuses.

## **LIGHTING**

2. A long life (pure lead) battery with 5-year full warranty and an additional 5 years pro-rated warranty.
3. All warranties shall be from the manufacturer and shall be in writing.

### **2.2 LAMPS**

- A. Lamps shall be as shown on the drawings and as detailed in the "Lighting Fixture Schedule".
- B. Fluorescent lamps shall be T5, energy saving type for all lamps 48" in length or greater.
- C. CONTRACTOR shall provide lamps for all lighting fixtures.
- D. Lamps shall be manufactured by Hubbell, DuroSite, Cree or equal.

## **PART 3 EXECUTION**

### **3.1 INSTALLATION**

- A. Provide all ballasts, sockets, brackets, channels and other devices as required for proper installation, operation and support of all fixtures. Fixtures shall be installed and supported in accordance with manufacturer's recommendations.
- B. Verify locations of process equipment and process pipe routing within the various buildings prior to fixture conduit rough-in to verify that interference does not occur. Where the light fixture locations either interfere with equipment/piping or where the equipment/piping will block the light from the fixture, review with the ENGINEER and adjust the locations as directed.
- C. All fixture enclosures shall be grounded.
- D. Provide access to all fixtures for proper maintenance, repair and operation.
- E. All fixtures shall have lamps installed. Lamps which fail prior to final acceptance by the OWNER shall be replaced with new lamps.
- F. Connect the individual exterior lighting fixtures to each photocell. Test and checkout the photo controls to verify proper operation. Adjust the direction to avoid artificial light sources.
- G. All Fixtures shall have lamps installed. Lamps that fail prior to final acceptance by the OWNER shall be replaced with new lamps. Lamps that fail after final acceptance by the OWNER shall be warranty items.

END OF SECTION



**DIVISION 40**

**PROCESS INTEGRATION**

**THIS PAGE LEFT BLANK INTENTIONALLY**

**SECTION 40 10 00**  
**PROCESS EQUIPMENT GENERAL REQUIREMENTS**

**PART 1 GENERAL**

1.1 DESCRIPTION

A. Scope:

This Section includes general provisions and requirements for all equipment specified in the Process Integration Subgroup (Division 40) to be furnished and installed as indicated on the Plans complete with safety guards, anchor bolts and lubrication. This Section also includes component name plates, structural process modification requirements and maintenance prior to final acceptance.

B. Related Work Specified Elsewhere

1. Cast-in-Place Concrete: Section 03 3000
2. Mortaring and Grouting: Section 04 0511
3. Division 26: Electric

1.2 QUALITY ASSURANCE

A. Reference Standards:

Unless otherwise specified, the Work of this Section shall conform to the applicable portions of the following Standard Specifications:

1. AFBMA - Antifriction Bearing Manufacturing Association
2. ANSI - American Standards Association
3. AMCA - Air Moving and Conditioning Association
4. ASA - American Standards Association
5. ASTM - American Society for Testing Materials
6. ASHRAE - American Society of Heating, Refrigerating and Air Conditioning Engineers
7. ASME - American Society of Mechanical Engineers
8. AWWA - American Water Work Association
9. FM - Factory Mutual
10. NEMA - National Electrical Manufacturers' Association
11. NFPA - National Fire Protection Association
12. UL - Underwriters Laboratories, Inc.

B. Deviations and Modifications

1. Motor Size

Deviation from motor sizes specified or indicated on the Plans recommended to accommodate any particular piece of equipment specified in various Sections of this Division shall strictly comply with these Specifications. The CONTRACTOR shall include with their bid any

## PROCESS EQUIPMENT GENERAL REQUIREMENTS

additional engineering and construction costs necessary to redesign the mechanical and/or electrical services recommended through CONTRACTOR by equipment manufacturer or supplier. No deviations will be permitted without written approval by the OWNER.

### 2. Structure/Process Modification

Modifications to the structure or process configuration recommended for ease of installation, operation or maintenance for a particular piece of equipment specified in various Sections of these Specifications shall strictly comply with these Specifications. The CONTRACTOR shall include with their bid any additional engineering and construction costs necessary to perform modifications recommended through the CONTRACTOR by equipment manufacturer or supplier. No modifications will be permitted without written approval by the OWNER.

### C. Workmanship

All Work shall be performed in accordance with latest accepted standards and practices for the trades involved. The workmanship shall be subject to the approval of the ENGINEER at all times.

Only craftsmen experienced in the Work to be performed will be allowed to do the Work. This applies particularly to skilled trades such as welding, pipe fitting, plumbing, and sheet metal work.

### D. Codes, Ordinances, Permits, and Inspections

All materials and equipment required for the Work and their installation shall conform to the laws of the Commonwealth of Kentucky and to all the codes, rules, regulations, and ordinances of the locality where the Work is to be performed. The CONTRACTOR shall secure all permits, licenses, inspections and tests required in connection with their Work. Upon completion of the Work, the CONTRACTOR shall secure and present to the OWNER a certificate of inspection and approval from the department having jurisdiction over their Work, if such be issued. All fees in connection with the above requirements shall be paid by the CONTRACTOR.

Any changes in the drawings and/or Specifications required to conform to the above codes, laws, rules and/or regulations shall be presented in writing to the ENGINEERS' office by the CONTRACTOR before submitting their proposal.

## PROCESS EQUIPMENT GENERAL REQUIREMENTS

After entering into the Contract, the CONTRACTOR shall be held to make all changes required to conform to the above ordinances, laws, rules, and/or regulations without extra expense to the OWNER, except in the instance of ordinances, laws, rules, and/or regulations which are revised or enacted subsequent to the time of signing the Contract.

### E. Design Drawings

The general arrangements, design, and extent of the Work prescribed in these Specifications are indicated and/or detailed on the accompanying drawings. Any discrepancies which may occur on the drawings and/or in the Specifications shall be presented in writing to the ENGINEER. No changes or alterations in the Work shall be made because of said discrepancies until approval of such changes or alterations has been secured from the ENGINEER.

In the event of disputes arising because of discrepancies between drawings of the Architectural, Mechanical, Process, and/or Electrical Trades, such disputes shall be presented in writing to the ENGINEER, whose decisions will be final.

All dimensions which tie mechanical, process and/or electrical installations to the building structure shall be thoroughly field checked for accuracy and possibility of interferences due to field conditions. Ignorance of such field conditions because of the CONTRACTOR's failure to field check the dimensions in question will be no excuse for additional compensation.

### F. CONTRACTORS' Interface

The CONTRACTOR shall be responsible to coordinate the furnishing and installation of all materials and labor required for a complete and operable facility.

The CONTRACTOR shall be responsible to include adequate appurtenances to complete installation of equipment furnished by him including motor starters when furnished as an integral part of a packaged piece of equipment or integral mechanical equipment system.

The CONTRACTOR shall be responsible for furnishing and installing the necessary piping to provide a complete and operable installation of all equipment and fixtures whether or not furnished by the CONTRACTOR.

### G. Apportionment of the Work

The CONTRACTOR shall classify and apportion all materials and performance of all labor to the several trades involved in accordance with all local customs, rules, regulations, jurisdictional awards, decisions, etc., insofar as they may apply and as required to efficiently execute the Work involved in this Contract regardless of the classification indicated in these Specifications.

## PROCESS EQUIPMENT GENERAL REQUIREMENTS

### H. Locations

All process equipment, plumbing fixtures, and mechanical equipment shall be in the exact locations as determined by the ENGINEER. It shall be the duty of the CONTRACTOR to request such exact locations from the ENGINEER sufficiently in advance of the time when such information will be required at the buildings so as not to interfere with progress of their Work.

### I. Points of Termination

The points of connection and termination of the Work under these sections of the Specifications are shown on the drawings or stated in the Specifications, but in case of doubt as to such points of connection or termination, the decision of the ENGINEER shall be final.

## 1.3 SUBMITTALS

### A. Shop Drawings and Product Data

Submit shop drawings and product data as required in Section 01 3300, Submittal Procedures, of these Specifications. Submittals where specified in various Sections of these Specifications will be reviewed for circuit design and representation, quality of proposed equipment, availability of components and compatibility to overall control and operation.

### B. Certificates

Each equipment manufacturer or supplier shall submit written certification that all equipment furnished is in compliance with the Occupational Safety Standards as specified in other Sections of this Division.

### C. Installation Inspection Report

Submit inspection report performed on installed equipment made by the representative of manufacturer or supplier. Report shall certify that equipment has been properly installed, lubricated, ready for operation and results of test operation. Include noise level and vibration readings.

### D. Operation and Maintenance Data

The CONTRACTOR shall submit operating instructions, repair parts lists, equipment manuals, and automatic control diagrams. The submittals shall be as required in Section 01 3300, Submittal Procedures.

The CONTRACTOR shall also provide the ENGINEER with additional copies of the above material, each copy to be bound in book or pamphlet form with approved fastenings and covers. Each bound copy shall include a set of the finally

## PROCESS EQUIPMENT GENERAL REQUIREMENTS

approved shop drawings of all equipment, fixtures, and accessories used on this Project.

### E. Record Drawings

Submit record drawings as required in Section 01 7700, Closeout Procedures. Drawings shall be 24" x 36" mylars of the Plans obtained from the ENGINEER and paid for by the CONTRACTOR, clearly marked by the CONTRACTOR with accurate field dimensions locating mechanical systems, equipment, piping, component parts, etc.

## 1.4 PRODUCT DELIVERY, STORAGE, AND HANDLING

Materials and equipment distributed, stored and placed upon or near the site of the work shall at all times be so disposed as not to interfere with work being prosecuted by other contractors in the employ of the OWNER, or with street drainage, fire hydrants or with access thereto, and not to hinder any more than may be necessary, the ordinary traffic of the street.

Materials may be stored on the site in locations designated by the OWNER, but the CONTRACTOR shall be responsible for securing stored materials from theft or damage.

All materials and equipment shall be handled in a manner to avoid damage or breakage and delay in the completion of the Work. The CONTRACTOR shall repair or replace, without cost to the OWNER and to the satisfaction of the OWNER, all items damaged or broken as a result of their operation.

All machined surfaces of the equipment subject to corrosion shall be protected by coating with grease immediately after finishing.

All flanges shall be protected prior to installation by means of wooden flanges bolted in place.

All parts of the equipment shall be carefully crated to facilitate shipping and handling. The crates shall be constructed to completely protect the equipment and shall be sufficiently strong to permit lifting and skidding without requiring additional bracing or reinforcement.

The CONTRACTOR shall notify the ENGINEER not less than two days in advance of the delivery of any equipment.

All materials shall be so delivered, stored, and handled as to prevent the inclusion of foreign materials and/or damage by water, breakage or other causes. Packaged materials shall be delivered in original unopened containers and shall be stored until ready for use. Packages or materials showing evidence of damage or contamination, regardless of cause, will be rejected. All materials which have been stored shall be

## **PROCESS EQUIPMENT GENERAL REQUIREMENTS**

subject to retest and shall meet the requirements of these Specifications at the time they are used in the Work and at the time of final acceptance of the Work.

The CONTRACTOR shall obtain a letter from the equipment manufacturer describing the recommended methods of outdoor or indoor storage of the equipment at the site and shall fully comply with such recommendations to be eligible for partial payments on such equipment.

All materials to be incorporated in the Work shall be properly arranged, covered and protected, and the CONTRACTOR shall be solely responsible for the safety of the same. Material improperly stored shall not be included in estimates for partial payment, or if already included, shall be deducted from subsequent estimates.

### **1.5 JOB CONDITIONS**

#### **A. Protection and Maintenance**

CONTRACTOR shall provide adequate protection of installed equipment and systems until final acceptance by the OWNER. All maintenance of installed equipment shall be the responsibility of the CONTRACTOR until final acceptance by the OWNER.

### **1.6 CUTTING AND PATCHING**

All minor cutting that may be necessary for the installation of the Work and any minor patching as a consequence thereof shall be done by the CONTRACTOR after review by the ENGINEER.

All major cutting of the structure necessary for the installation of the mechanical Work and major repairs required as consequence thereof shall be done by the CONTRACTOR, after review by the ENGINEER.

## **PART 2 PRODUCTS**

### **2.1 MATERIALS**

When specific manufacturers or trade names are mentioned in these Specifications, and/or on the drawings, they are used as the design criteria and to establish a minimum of quality standard.

Any substitution made that may affect building size or process function shall be deemed to be made for the convenience of the CONTRACTOR, and all shall be brought to the attention of the ENGINEER at an early date for consideration. Any additional costs resulting therefrom shall be borne by the CONTRACTOR.

The CONTRACTOR shall accept full responsibility that said substitution shall function as required by the process and shall not require additional building space or additional structural requirements. The CONTRACTOR shall also be responsible for all redesign expenses incurred because of the substitution.



## PROCESS EQUIPMENT GENERAL REQUIREMENTS

Any items required to complete the Work and not specifically mentioned herein, shall conform fully to the quality pattern established by these Specifications.

All materials shall be new and be the standard products of the manufacturer. Seconds, rejects, or damaged materials will be rejected by the CONTRACTOR. The ENGINEER reserves the right to disapprove and reject any materials, proposed or installed which fail to meet these quality standards. The CONTRACTOR shall, at their own expense, remove and replace with approved materials, any materials which do not comply with these standards.

### 2.2 FABRICATION

Provide for possible adjustments in the field of mechanical and process work fabrications. Adjustments shall allow for adjustment to avoid interferences, installation of equipment or connecting to other Work.

### 2.3 EQUIPMENT

#### A. General

Unless furnished as integral parts of mechanical or process equipment, appurtenances such as remote operation switches or push buttons, pilot lights, starter relays, overloads or other items shall conform to and be installed as specified herein and any related Sections.

#### B. Low Voltage Motors (600 Volts and Below)

##### 1. General Requirements

###### a. Scope

This Specification covers three phase squirrel cage induction motors NEMA Design "A", "B", and "C" high efficiency motors.

###### b. Standards

All motors shall be in accordance with NEMA Standard MG1-1978, or the latest revision insofar as it is applicable. Motors shall also comply with the applicable portions of the National Electric Code.

##### 2. Electrical Requirements

###### a. Voltage and Frequency

Motors 1/3 HP and smaller shall be rated for service on 120 volt, single-phase service, unless identified differently in the Specifications or on the Drawings.

## PROCESS EQUIPMENT GENERAL REQUIREMENTS

Standard motors 1/2 HP through 100 HP shall be rated 230/460 volts; motors above 100 HP shall be rated 460 volts. Motors will be rated for operation on a three phase, 60 HZ power supply.

### b. Operating Characteristics

#### 1) Torques

Motors shall meet or exceed the locked rotor (starting) and minimum breakdown torques specified in NEMA Standards for Design B for the ratings specified.

Motors shall be of the NEMA Design required to meet the torque requirements of the driven load to which it is to be attached.

#### 2) Currents

Locked rotor (starting) currents shall not exceed NEMA Design B maximum values for the specified rating. Motors shall be capable of a 20 second stall at six times full load current without injurious heating to the motor components.

#### 3) Efficiency

Motors shall have a minimum and nominal full load efficiency which will meet or exceed the values listed in the motor efficiency tables 3(a) and 3(b); tested in accordance with NEMA Test Standard MG1.12.53a, IEEE Test Procedure 112, Method B, using accuracy improvement by segregated loss determination including stray load loss measurements. The minimum efficiency shall be guaranteed. Motors 250 HP and larger shall have a full load nominal efficiency of not less than 95% with a guaranteed minimum of 94%.

#### 4) Power Factor

The power factor for 3,600 and 1,800 rpm, 3 through 250 HP ratings at full load, at full voltage shall be a minimum of 83%. Six-pole ratings will be excluded from this requirement.

### c. Service Factor and Ambient

Standard motors will be rated for a 1.15 service factor in 40C ambient.

### d. Insulation

## PROCESS EQUIPMENT GENERAL REQUIREMENTS

- 1) Standard motors shall have a full Class B insulation system.
  - 2) Standard motors shall be dipped and baked in polyester varnish to consolidate the winding.
3. Motor Efficiency Tables (At Full Load)
- a. TEFC
4. Mechanical Requirements
- a. Frame Size  
  
Horsepower/frame relationship shall conform to the latest NEMA Standard for T frame motors.
  - b. Enclosure
    - 1) Motors shall be open drip-proof, TEFC, explosion-proof, or other types of construction as called for in other sections of these Specifications.
    - 2) Motor frame and end shields shall be of cast iron or cast aluminum construction using alloys with low copper content. Conduct box may be either steel or aluminum.
  - c. Bearings
    - 1) All motors shall have anti-friction bearings, sized for a L-10 life of at least 25,000 hours under minimum V belt sheave sizes for maximum loading conditions (see NEMA Standard MG1-14-42) or 125,000 hours L-10 life for a direct connected load.
    - 2) Aluminum end shields shall have a cast-in steel or cast iron bearing insert.
    - 3) Bearing housings shall be regreasable with provisions for purging old grease.
    - 4) Bearings shall be preloaded with a bearing loading spring to minimize noise and increase bearing life.
  - d. Miscellaneous

## PROCESS EQUIPMENT GENERAL REQUIREMENTS

- 1) Conduit box shall be diagonally split and rotatable in 90° increments.
- 2) External hardware shall be plated to resist corrosion.
- 3) External paint shall withstand industrial environments or shall be as called for in other Sections of these Specifications.
- 4) Nameplates shall be of stainless steel and stamped per NEMA Standard MG1-10-37. Nameplate information shall include the nominal efficiency value per Standard MG1-12.53b and the manufacturer's minimum guaranteed efficiency value.

### e. Motor Vibration

Motor vibration, when factory tested by manufacturer, shall not exceed the values of NEMA MG-1 12.05; that is, 0.0010 inches for 3,600 rpm motors, 0.0015 inches for 1,800 rpm motors, and 0.0020 inches for 1,200 rpm motors.

### 5. Noise Level

All noise levels shall be less than the maximum requirements of OSHA, NEMA, and IEEE Standards.

### 6. Tests

Tests shall be performed on each design to assure compliance with the design criteria of this Specification.

## **PART 3 EXECUTION**

### 3.1 INSTALLATION

#### A. Equipment

##### 1. General

The CONTRACTOR's attention is directed to the fact that certain equipment must be installed before housing and/or enclosures are installed or completed. Doors and other access openings in some cases are not large enough to permit passage of the equipment completely assembled. The CONTRACTOR shall thoroughly investigate these conditions prior to fabrication or shipment.

Component parts furnished as part of a packaged equipment system shall be installed with the mechanical Work, ready for connection as

## PROCESS EQUIPMENT GENERAL REQUIREMENTS

specified in Division 26, Electrical. Electrical connections between component mechanical parts shall be inclusive to mechanical Work.

Components such as remote operation controls, pilot lights, overloads or others not furnished as integral packaged pieces of equipment shall conform to and be installed as specified in Division 26, Electrical.

### 2. Supports and Anchors

Provide bases, pads, platforms, hangers, clamps, or embedded inserts necessary for proper support and/or anchoring of mechanical and process Work. The CONTRACTOR shall be responsible for the proper sizes, locations, and quantities of these bases and pads where same are to be on concrete floor slabs, and shall provide all anchor bolts, sleeves, and setting templates for the mechanical equipment and machinery. Bases and/or pads are to be provided for each piece of mechanical equipment and machinery whether shown or not shown on the drawings. Inserts to be embedded in concrete shall conform to and be installed as specified in Sections 03 1500, Concrete Accessories. Detailed specifications for anchoring are included in other Sections of these Specifications.

All necessary anchor bolts, nuts, washers, and sleeves shall be furnished as per the manufacturer's recommendations and shall be made of ample size and strength for the purpose intended.

All anchor bolts, bolt sleeves, washers and nuts supplied shall be stainless steel unless otherwise specified. Setting templates and working drawings for installation shall be furnished.

Unless otherwise indicated on the Plans or specified elsewhere, anchor bolts for items of equipment mounted on baseplates shall be long enough to permit 1-1/2 inches of grout beneath the baseplate and to provide adequate anchorage into structural concrete. Unless otherwise noted, all equipment baseplates shall be furnished complete with openings for grout.

Mechanical equipment resting on concrete foundations, bases or pads shall rest on a level and uniform bearing surface with grout when vibration isolation is not required or specified. Grout shall be nonshrink, nonstaining Type V.

### 3. Electrical Service

The CONTRACTOR shall furnish all motors required in connection with their Work and he shall mount or install all their motors in their finished locations.

Electrical components required and furnished for mechanical or process equipment systems provided as complete system by the manufacturer or

## PROCESS EQUIPMENT GENERAL REQUIREMENTS

Subcontractor, and automatic temperature control systems together with any power and control interface wiring shall be the responsibility of the CONTRACTOR. CONTRACTOR shall perform this Work in accordance with all requirements of the electrical Specifications. The CONTRACTOR shall be responsible for the proper operation of their equipment and shall furnish all wiring and control diagrams to ensure proper operation of same.

### B. Painting

Shop priming and finish coats including preparation shall be as specified in Section 09 9000 Painting. All iron and steel surfaces shall be protected by suitable paint or coatings applied in the shop or point of fabrication. Surfaces which will be inaccessible after assembly or installation shall be finish coated to provide protection for the life of the equipment. Surfaces which have been inadequately coated or require touch up in the field shall be repainted. The repainting shall be the responsibility of the CONTRACTOR and performed to the satisfaction of the ENGINEER.

### C. Sleeves

Provide sleeves where pipes or ducts pass through walls or floors necessary for installation and as specified elsewhere for process or mechanical Work. Sleeves for covered pipe or ducts shall be of proper size to allow the covering to pass through unless otherwise directed or specified elsewhere.

### D. Plates

Ceiling, floor or wall plates shall be installed at all points where exposed pipes pass through walls, ceiling, or floors. Plates shall be nickel-plated sectional, pressed steel plates with positive catches.

### E. Lubrication of Equipment

After installation of any equipment is complete such as motors, pumps, compressors, etc., which depends on lubrication for efficient operation, they shall be lubricated in accordance with the manufacturer's recommendations. The CONTRACTOR shall furnish all oil and grease required to place all of the equipment in initial operation. Oil and grease shall be in accordance with the equipment manufacturer's recommendations. Lubrication points on equipment shall be easily accessible with all points of application provided with one standard fitting throughout the entire job for greases or placing oil. Where equipment is furnished by the manufacturer with different fittings, the CONTRACTOR, at their own expense, shall provide and install standard fittings. All fittings shall be installed in a readily accessible location or provided with extension lines for ease in lubrication. Lubrication shall be done before any test runs will be permitted or equipment placed in final operation.

## PROCESS EQUIPMENT GENERAL REQUIREMENTS

### F. Identification

All mechanical equipment including pumps, air handling units and each and every valve and regulator shall be identified in accordance with other Sections of these Specifications and in accordance with OWNERS method of equipment identification. Nameplates shall be provided on a new panels and equipment.

### G. Welding

Blower air supply lines shall be welded.

All natural gas lines 1-1/2 inches and larger shall be welded. If desired, piping less than 1-1/2 inches may be welded; however, sample welds shall be submitted for ENGINEER's approval.

Material shall be clean either by wire brushing or by sandblasting, if needed, prior to welding, depending upon the condition of the material. If grease, or other foreign materials of the same nature are present, cleaning shall be done by a suitable solvent.

Black steel pipe and fittings may be welded by either oxyacetylene or electric arc method.

All welding shall be done by first class pipe welders meeting qualifications covered by the American Standard Code for Pressure Piping (ASA B31.1).

Welding shall conform to the standards and requirements of this code and all applicable state and local codes. The OWNER reserves the right to require qualifying demonstrations of any welder assigned to the job by this CONTRACTOR.

Branch connections shall be made with welding tees. Welding ells shall be used for changing pipe directions. Scarf welding of branch pipe connections and use of mitered joints shall not be permitted.

All slag, dirt, and loose pieces of metal shall be removed from the interior of the vessels, jackets, nozzles and piping. All welds are to be thoroughly cleaned and wire brushed and weld spatter removed. Grinding of finished welds is not desired except where specified.

### H. Safety Guards

Provide and install safety guards for all belts, gears, shafts or other reciprocating, rotating or moving parts of equipment whether shown on the Plans or required by ANSI B15.1, Safety Standard for Mechanical Power-Transmission Apparatus. Paint all guards safety yellow unless otherwise directed by ENGINEER or specified elsewhere.

## PROCESS EQUIPMENT GENERAL REQUIREMENTS

Guards shall be fabricated from galvanized or aluminum-clad sheet steel no thinner than 16 gage or galvanized 1/2-inch mesh expanded metal. Each guard shall allow for easy installation and removal. All necessary supports and accessories shall be included with guards. Supports and accessories, including bolts, shall be hot dip galvanized.

Safety guards in outdoor locations shall prevent the entrance of rain and dripping water.

### I. Nameplates

Provide nameplates on each component of equipment, unless otherwise specified. Plates shall clearly identify manufacturer catalog or model number, serial number and other data pertinent to operation. Securely attach plates to components or have data stamped or cast into the body. Plates or stampings shall be located in a position to be easily and fully visible after components are installed without removing any parts from the component. Only rigid metal plates riveted or screwed to components will be acceptable.

## 3.2 FIELD QUALITY CONTROL

### A. Testing

During and after installation, those tests required by the local, county and state inspection bureaus, the OWNER or the ENGINEER, shall be performed in strict accordance with the department concerned and at the full expense of the CONTRACTOR.

The CONTRACTOR shall furnish all equipment, water, compressed air, apparatus, and labor necessary for the test. All defects disclosed by the tests shall be rectified by the CONTRACTOR without cost to the OWNER. Test shall be made under the direction of and subject to the approval of the OWNER or the ENGINEER. Tests required after installation are outlined herein and shall endure for not less than 48 hours.

All equipment shall be tested as in normal operating service unless specific rating tests are required as results of questionable performance.

Gages and equipment, etc., which may be damaged by the tests shall be valved off or removed before testing.

Special tests required for certain apparatus are specified under the specific headings for that apparatus.

In general, all visible or audible leaks shall be fixed regardless of previous testing results.

### B. Final Inspection



## PROCESS EQUIPMENT GENERAL REQUIREMENTS

Upon completion of the Work, the CONTRACTOR shall conduct a complete inspection of all items of Work instituted by the Contract obligations; and make whatever corrections and adjustments deemed necessary to a well functioning system, same to meet the satisfaction of the ENGINEER and the OWNER.

The CONTRACTOR shall signify their readiness for final inspection in writing to the ENGINEER. The time of inspection may occur at the time of "Operating and Instructions." The inspection shall be made in the presence of the OWNER and ENGINEER.

### 3.3 EQUIPMENT STARTUP

After completion of the installation, all systems and equipment shall be tested by the CONTRACTOR in the presence of the ENGINEER under actual operating conditions. Tests shall be performed according to manufacturer's recommendations.

Installed equipment shall be operated under full working load conditions before being accepted by the ENGINEER as ready for satisfactory operation. Each piece of equipment shall be certified by the representative that installation is correct and ready for satisfactory operation.

The manufacturer or supplier of each piece of equipment shall provide the services of a representative to field review installation procedures with the CONTRACTOR, inspect installed equipment and adjust for satisfactory operation.

## **PROCESS EQUIPMENT GENERAL REQUIREMENTS**

The CONTRACTOR shall include with their bid the services of all required equipment manufacturer's field service technician for a period necessary to complete the work to the satisfaction of the ENGINEER and OWNER. The representative shall provide all necessary tools and testing equipment required including noise level and vibration sensing equipment. A written report covering the technician's findings and installation approval shall be submitted to the ENGINEER covering all inspections and outlining in detail any deficiencies noted.

Specific requirements, if any, for a particular system or piece of equipment are contained in the particular specification sections. The CONTRACTOR's responsibility relative to coordinating these services are contained in Section 01 7700, Closeout Procedures.

### **3.4 ADJUSTMENT AND CLEANING**

Before turning the project over to the OWNER, clean all fixtures, piping, covering, exposed metal surfaces and leave all in clean condition at the end of the Work and remove from the premises all refuse, dirt and rubbish which are a result of the mechanical Work or workmen. Also, remove from the premises all cartons, scrap, and major debris at least once a week during progress of the Work.

All instruments used in the checking, adjusting, and balancing shall be accurately calibrated and maintained. Accuracy tests on instruments shall be performed in the presence of and whenever requested by the OWNER or the ENGINEERS.

Air and water balance and checking shall not begin until systems have been completed and are in full working order. The CONTRACTOR shall put all heating, ventilating, and air conditioning systems and equipment into full operation and shall continue the operation of same during each working day of testing and balancing.

### **3.5 SPARE PARTS AND SPECIAL TOOLS**

Spare parts shall be provided for each piece of equipment as specified in various Sections of this Division and shall be delivered to the Project site in boxes with labels identifying contents. Special tools necessary for maintenance by OWNER shall be furnished with each particular piece of equipment. These tools shall be included whether or not specified in various Sections of this Division.

Delivery of all parts and/or special tools shall be made prior to Contract Closeout as specified in Section 01 7700, Closeout Procedures. Storage shall be where determined by ENGINEER.

**END OF SECTION**

## **SECTION 40 15 00 PROCESS PIPING**

### **PART 1 GENERAL**

#### **1.1 SCOPE OF WORK**

- A. CONTRACTOR shall provide labor, materials, equipment, tools and services required for the furnishing and installation of process piping, complete with pipe, fittings, valves, connections, and accessories such as hangers, supports and operators as indicated on the Plans or as required for a complete and functioning system.
- B. Piping shall be furnished and installed of the materials and sizes and at elevations and locations shown, indicated or specified elsewhere in the Contract Documents and/or in this specification.

#### **1.2 RELATED WORK SPECIFIED ELSEWHERE**

- A. Work of the following Sections applies to the Work of this Section. Other Sections of the Specifications, not referenced below, shall also apply to the extent required for proper performance of this Work.
  - 1. Section 01 3300: Submittals
  - 2. Section 03 3000: Cast-in-Place Concrete
  - 3. Division 26: Electrical

#### **1.3 REFERENCE STANDARDS**

- A. Unless otherwise specified, the Work for this Section shall conform to the applicable portions of the following Standard Specifications:
  - 1. ANSI - American National Standards Institute
  - 2. ASME - American Society of Mechanical Engineers
  - 3. ASTM - American Society for Testing and Materials
  - 4. AWWA - American Water Works Association
  - 5. NCPWB - National Certified Pipe Welding Bureau
  - 6. NEMA - National Electrical Manufacturers' Association
  - 7. UL - Underwriters Laboratories

#### **1.4 SYSTEM DESCRIPTION**

- A. General:
  - 1. Drawings show general arrangement, direction, and sizes of pipes. Drawings are not intended to show every offset and fitting, or every structural difficulty that may be encountered. CONTRACTOR shall install the piping and appurtenances to suit, and to avoid interference with

## PROCESS PIPING

installation, operation, and maintenance of fixtures, equipment, or other piping. CONTRACTOR shall verify dimensions and measurements prior to furnishing and installing the Work specified herein.

2. CONTRACTOR shall provide piping with necessary hangers, anchors, and supports as specified herein and as indicated. Piping supported by equipment to which it is connected is not acceptable.

### 1.5 SUBMITTALS

#### A. Shop Drawings and Product Data:

##### 1. Shop Drawings:

- a. Submit shop drawings as required in Sections 01 3300, Submittal Procedures and 40 1000, Process Equipment General Requirements, showing the layout of the piping systems complete with piping, supports, and structural dimensions.
- b. Shop drawings shall identify all joints, valves, fittings, component parts, pipe material, insulation where required, and valve identification codes. Supports and anchors shall be shown in the layout and detailed.
- c. CONTRACTOR shall verify in the field, the location, position, and size of existing piping (including buried pipes), as indicated on the Contract Drawings and Specification to be reused, forming a part of the new process piping layout.
- d. Process piping Shop Drawings submitted to ENGINEER for review shall clearly indicate the location, position (elevation), and size of existing piping to be reused.

#### B. Product Data:

1. Submit product data as required in Section 01 3300, Submittal Procedures. Include manufacturer's recommendations for installation, connection to automatic operators, and instructions for proper operation and maintenance.
  - a. Valve operator data shall also include information necessary for any external controls, wiring or hydraulics to be furnished, installed or connected by other Work.

#### C. Welders Certification:

1. Submit certification of welders and/or welding process for fabrication and/or field assembly.

## PROCESS PIPING

### D. Record Drawings:

1. Submit record drawings as required in Section 40 1000, Process Equipment General Requirements.

## 1.6 Quality Assurance

### A. Welding, Brazing or Soldering:

1. Qualify welding/brazing processes and welder/brazer performance in accordance with AWS B2.2, Standard for Brazing Procedure and Performance Qualification, or ASME Boiler and Pressure Vessel Code, Section IX. Certify that each welder/brazer has satisfactorily passed AWS or ASME qualification tests for welding/brazing processes involved and, if pertinent, have undergone re-certification.
2. Welding and brazing procedures shall address cleaning, joint clearance, overlaps, internal purge gas, purge gas flow rate, and filler metal.
3. Certification of procedures and operators applies for both shop and job site welding and brazing of pipe work.
4. If required, apply for an obtain a "Hot Work Permit" from OWNER.
5. Performance qualification of welders/brazers shall remain in effect indefinitely unless the welder/brazer does not weld or braze with the qualified procedure for a period exceeding 12 months, or there is a specific reason to question the ability of the welder/brazer.
6. Soldering: Conform to ASME B31.3, Process Piping and Copper Development Association recommended practices.

- B. All grooved joint couplings, fittings, valves and specialties shall be the products of a single manufacturer. Grooving tools shall be of the same manufacturer as the grooved components. All castings used for coupling housings, fittings, valve bodies, etc. shall be dated stamped for quality assurance.

## 1.7 DELIVERY, STORAGE, AND HANDLING

### A. Handling:

1. Pipe and special castings shall be handled in such a manner as to avoid any damage to pipe or specials.
  - a. In the event pipe coating is damaged, especially on the inside of the pipe, the damaged area shall be cleaned by wire brushing and then recoated with an approved coating similar to that specified for the pipe.

## PROCESS PIPING

### B. Storage:

1. Store materials in enclosures or under protective coverings. Keep inside of pipe fittings and valves free of dirt and debris. Store in a manner for easy identification of all materials.

## 1.8 SPARE PARTS

- A. Furnish spare parts data for each different item of material and equipment specified, after approval of the related submittals and not later than delivery of equipment specified herein.
- B. Pack in containers bearing labels clearly designating contents and pieces of equipment for which the part is intended. Each part shall be identified with a tag bearing its part number and a part description.

## PART 2 PRODUCTS

### 2.1 PIPE SYSTEM

#### A. General:

1. Pipe systems shall conform to the materials or component performance as specified herein and the pipe schedule as shown on the drawings.

#### B. Ductile Iron Pipe:

##### 1. Material:

- a. Ductile iron pipe shall be centrifugally cast in metal or sand-lined molds with materials, dimensions, test and other details in complete conformance with AWWA Standard C151 (ANSI A21.51). Unless otherwise indicated, minimum wall thickness shall not be less than that of Thickness Class 52, as outlined in AWWA Standard D150 (ANSI A21.50).
- b. Provide exterior asphalt coating for buried pipe, primer or epoxy-polyamide for above ground inside facilities pipe.
- c. Unless otherwise noted, all ductile iron pipe shall be cement mortar lined in accordance with AWWA C104 Standard. Scum, sludge, supernatant, and centrate piping shall be fusion bonded epoxy lined pipe and fittings in accordance with AWWA C116 Standard.
- d. Ductile iron pipe shall be manufactured by American Ductile Iron Pipe Company or United States Pipe and Foundry Company.

## PROCESS PIPING

### 2. Joints:

- a. Underground fittings shall be furnished with mechanical joints and pipes furnished with push-on joints. Above grade interior piping shall be flanged or grooved joint types. The types of joints shall meet the following applicable requirements:
  - (1) Push-on Joints: Joints shall be compression gasket type conforming to AWWA C111 with spigot of pipe marked to visually determine when the spigot is fully seated in the bell of the adjoining section. Push joints within 80 feet of an elbow or tee fitting including the fitting shall be use retainer type glands.
  - (2) Flange Joints: Flanges shall have full face neoprene gaskets, 1/8" thick and conform to ANSI B16.1. Carbon steel bolts shall conform to ASTM A449 with nuts conforming to ASTM A563 Grade B. Bolt head and nuts shall be hex type, zinc plated.
  - (3) Mechanical Joints: Mechanical couplings and split flanges for grooved pipe shall have a housing with grips to secure onto the pipe ends and encase an elastomeric gasket seal. Housings shall be ASTM A536 ductile iron cast in two or more segments and secured together by no less than two ASTM A449 electroplated steel oval head bolts. Conform to AWWA C606 or Victaulic Style 31, or equal, for grooved ends.
    - (a) For grooved end pipe, direct connections to IPS/steel pipe sizes, couplings shall include housings cast with offsetting-angle-pattern bolt pads for joint rigidity (Victaulic Style 307 or equal)

### 3. Fittings:

- a. Pipe fittings for ductile iron pipe shall be ductile iron as described in AWWA Standard C110 (ANSI A21.10). The coating and linings of the fittings shall be as specified for the ductile iron pipe unless otherwise indicated. Unless otherwise noted, all bends and fittings shall be long radius type unless approved by the ENGINEER.
- b. Grooved end fittings shall comply with ANSI A21.10 / AWWA C110 for center to end dimensions and AWWA C153 and ANSI A21.10 / AWWA C110 for wall thickness.
- c. Flanges shall conform to ANSI B16.1. Carbon steel bolts shall conform to ASTM A449 with nuts conforming to ASTM A563

## PROCESS PIPING

Grade. Stainless steel bolts and nuts shall conform to ASTM A320. Bolt head and nuts shall be hex.

4. Restrained Joints: Where indicated on the drawings, CONTRACTOR shall provide mechanically restrained joints for direct buried ductile iron pipe.

Joint restraint shall be in accordance with pipe manufacturer's recommendations and the restrained joint shall be capable of disassembly, if necessary in the future, by using simple hand tools.

- a. Mechanical joint restraint assembly rings may be used to provide restraint. Metalug, manufactured by EBAA Iron, Inc. or approved equal.
- b. Proprietary joint restraint system as specified by the pipe manufacturer may be used to provide restraint. U.S. Pipe, HP Lok, and American Cast Iron Pipe flex-ring restrained joint systems may be used, or approved equal.
- c. Gripper-type gaskets may not be used and traditional mechanical joint pipe does not provide joint restraint. Grooved and shoulder joints may not be used in direct buried applications.

### C. Polyvinyl Chloride Pipe (PVC):

1. Polyvinyl Chloride Pipe (PVC) and fittings shall be in accordance with ASTM D-1784, D-1785, D-2464, and D-2467, Schedule 80 as indicated in the pipe schedules with socket welded or flanged joints.
2. Provide unions or flanges at all valves and equipment. All pipe connections shall be made in conformance with the manufacturer's recommendations including supply of gaskets, where necessary.
3. Grooved end couplings for PVC pipe shall be Victaulic Style 77, or approved equal.
4. Polyvinyl Chloride pipe and fittings shall be "Chamorro" as manufactured by Celanese Piping Systems, Plastiline, Inc., R & G Sloane; or equal.

### D. Polyethylene Pipe:

1. Material:
  - a. Pipe shall be listed for NSF Standard 61 and manufactured to AWWA C901 and C906 Standards. Pipe shall be PE3408 in accordance with ASTM D3350 DR 7.3. Pipe shall be sized as ductile iron OD with permanent identification of the piping service provided by co-extruded blue strips into the outside of the pipe surface. Stripes painted on the surface are not acceptable.



2. Fittings:

- a. Fittings shall meet the material requirements established for the pipe to which the fitting is to be joined.

Fittings fabricated from pipe shall be manufactured from pipe stock with a wall thickness at least 25% greater than that of the pipe to which the fitting is to be joined or shall be otherwise externally reinforced so that the fitting carries a pressure rating equal to that of the pipe from which it is made.

E. Stainless Steel Pipe:

1. Material:

- a. Stainless steel pipe greater than 3-inch diameter shall be ASTM A778, Type 304L, Schedule 5S, unless otherwise indicated on the plans. After all shop operations have been completed, all stainless steel material shall be full immersion pickled, rinsed with water, and passivated.
- b. ASTM A312, Type 304/304L, Schedule 10S pipe with grooved ends or plain ends for use with the Vic-Press 304™ piping system, or equal, may be used for air and water piping.

2. Fittings:

- a. Fittings shall be ASTM A774, Type 304L. After all shop operations have been completed, all stainless steel material shall be full immersion pickled, rinsed with water, and passivated. Wall thickness shall equal that of pipe. Fittings shall be smooth standard fittings with dimensions conforming to ANSI B16.9.
- b. Grooved end fittings shall be manufactured from stainless steel material, wrought type conforming to ASTM A403, or factory-factory fabricated from stainless steel pipe conforming to ASTM A312.
- c. Vic-Press 304™ fittings, or equal, shall be manufactured from cold drawn, austenitic stainless steel with elastomer O-ring seals (grade to suit the intended service). Fittings shall be rated for operating pressures to 300 psig (2065 kPa) CWP.

3. Joints:

- a. Joints shall be grooved end or butt-weld per American Welding Society Standards except where valves or equipment requires flanged connections. Flanged joints shall be fabricated from SS 304L per dimensions of AWWA C207 Class B ring flanges.

## PROCESS PIPING

Provide gaskets, bolts, and nuts per pipe manufacturer recommendations for intended service.

- b. Grooved joint couplings shall consist of two ASTM A536 ductile iron or ASTM A351 grade CF8M stainless steel housing segments. Couplings shall include a pressure responsive elastomer gasket (grade to suit the intended service), with ASTM A449 electroplated steel or ASTM F593/F594 stainless steel bolts and nuts.
  - (1) Rigid Type: Victaulic Series 89 / W89 (ductile iron) or Series 489 (stainless steel), or equal. Housing key shall clamp the bottom of the groove.
  - (2) Flexible Type: Victaulic Series 77 (ductile iron) or Series 77S (stainless steel), or equal.
  - (3) For sizes through 4", Victaulic Installation-Ready couplings may be used on Schedule 10S stainless steel pipe for services to 300 psi (2065-kPa), suitable for direct stab installation without field disassembly. Victaulic Style 107H (rigid) or Style 177 (flexible), or equal.
- c. Installation-Ready gaskets shall be grade EHP suitable for water or dry air to +250 deg F, or Nitrile grade T suitable for air with oil vapors to +180 deg F.

### F. Copper Pipe:

- 1. Material:
  - a. Copper piping shall be Type K, and shall meet the specifications of the ASTM Standard B-88 for underground service. The minimum diameter of a service shall be 1-inch.
- 2. Fittings:
  - a. Fittings used with this pipe above grade (interior) shall be flare-type fittings, below grade (underground) shall be compression-type fittings and shall conform to AWWA Standard C800.
  - b. Grooved end fittings shall be manufactured to copper-tube dimensions of cast bronze per ASME B16.18 or wrought copper per ASME B16.22.
- 3. Joints:
  - a. Copper joints shall be thoroughly cleaned and the end of pipe uniformly flared or cut by a suitable tool to the bevel of the fitting

## PROCESS PIPING

used. Wrenches shall be applied to the bodies of the fittings where the joint is being made and in no case to a joint previously made.

- b. Grooved joint couplings shall consist of two ductile iron housing segments cast with offsetting angle-pattern bolt pads, pressure responsive gasket, and ASTM A449 electroplated steel bolts and nuts. Installation-Ready, for direct stab installation without field disassembly. Victaulic Style 607H. Installation-Ready gaskets shall be grade EHP suitable for water or dry air to +250 deg F, or Nitrile grade T suitable for air with oil vapors to +180 deg F.

### 2.2 WALL PIPE AND SLEEVES

#### A. General:

- 1. Pipes and sleeves shall be as specified herein.

#### B. Wall Pipe:

- 1. AWWA C110 with cement mortar lining, inside diameter and connections compatible to pipe system, shall be flanged or mechanical joint as shown on the drawings, tapped bolt holes, water stop.

#### C. Sleeves:

- 1. Sleeves shall be schedule 40 pipe and be galvanized steel, or plastic, GPT or equal for pipe less than 30 inches.

### 2.3 LINK-TYPE SEALS

- A. Link-type seals shall be interlocking expandable type of molded synthetic rubber segments with 304 stainless steel bolts and nuts and pressure plate.

- B. Seals shall be as manufactured by Thunderline or equal.

### 2.4 SLEEVE-TYPE COUPLINGS

- A. Pressure rating at least equal to that of related pipeline.

- B. Manufactured by Dresser Mfg. Div., Bradford, PA; Rockwell International, Municipal & Utility Div., Pittsburgh, PA; R.H. Baker & Co., Inc., Los Angeles, CA; or equal.

- C. Couplings for Buried Pipe: Cast iron sleeve or steel sleeve and retainer with fusion bonded epoxy coating, Dresser Style 53 or 153, Rockwell Style 431, Baker Series 228, or equal. Couplings provided with type 304 or 316 stainless steel bolts and nuts.

## PROCESS PIPING

- D. Couplings for Exposed Pipe: Steel; Dresser Style 38, 127 or 128 Rockwell Style 411, Baker Series 200, or equal. Couplings provided with type 304 or 316 stainless steel bolts and nuts. Provide tie rods across couplings as shown.
- E. Furnished with pipe stop removed.
- F. Provided with gaskets of composition suitable for exposure to the liquid or gas carried within pipe.
- G. Provide thrust restraint as required.

### 2.5 SPLIT-SLEEVE COUPLINGS

- A. Pressure rating as published in the manufacturer's latest information and suitable for the application.
- B. Manufactured by Victaulic Company; Depend-O-Lok; Doraville, GA, or equal.
- C. Rolled double-arched housing, steel conforming to ASTM A36; or stainless steel conforming to ASTM A240.
- D. Furnished with restraint rings where restrained joints are required.
- E. Provided with gaskets of composition suitable for exposure to liquid or gas carried within the pipe.
- F. Provide thrust restraint as required.

### 2.6 FLANGE ADAPTERS

- A. Cast iron adapters for transitioning from plain end ductile iron to flanged fittings, 125 # bolt pattern. (ANSI B16.1). Flange adapters shall have ductile iron set screws to securely grip the pipe end. Flange adapters shall be as manufactured by EBAA Iron, Inc., Victaulic Depend-O-Lock or ENGINEER approved equal.
- B. Grooved Joint Flange Adapters: Flat face, ductile iron housings with elastomer pressure responsive gasket, for direct connection to ANSI Class 125 or 150 flanged components. Victaulic Style 341 (ductile iron pipe); Style 741 / W741 (steel pipe); or Style 441 (stainless steel pipe), or approved equal.

### 2.7 CORPORATION STOPS

- A. Corporation stops for connection to ductile iron or steel piping shall be constructed of brass or bronze, suitable for 150 psi test pressure. Acceptable manufactures include Mueller, Clow, or approved equal.

### 2.8 FLANGE ADAPTER COUPLINGS

## PROCESS PIPING

- A. Flange adapter couples shall be of the size and pressure rating required for each installation and shall be suitable for use on the type of pipe specified. Couplings shall have a sufficient number of factory-installed anchor studs to meet or exceed the test pressure rating of 100 psi.

### 2.9 FLEXIBLE COUPLINGS

- A. Flexible couplings shall be either split type or sleeve type, as indicated on the Drawings.
  - 1. Sleeve type couplings shall be used on buried piping. Couplings shall be provided with stainless steel bolts and nuts, unless indicated otherwise.
- B. Couplings shall be constructed of malleable iron in accordance with ASTM A536, Grade 65-45-12 housing clamps in two or more parts, a single chlorinated butyl composition sealing gasket with a c-shaped cross section and internal sealing lips projecting diagonally inward, and two or more oval track head type bolts with hexagonal heavy nuts conforming to ASTM A183 and A449 and A194. Bolts and nuts shall be electroplated steel or series 300 stainless steel.
- C. Couplings shall be provided with gaskets of a composition suitable for exposure to the liquid within the pipe.
- D. Provide thrust restraint as required.

### 2.10 PRESSURE GAUGES

- A. Each pressure gauge shall be direct mounted and composed of a cast aluminum case with a 4" diameter dial with a clear glass crystal window, a 3/8" shut-off valve, and a bronze pressure snubber.
- B. Diaphragm seals shall be provided between shut-off valve and pressure gauge.
- C. Gauges shall be weatherproof.
- D. Face dial shall be white finished aluminum with jet black graduations and figures. Face dial shall also indicate the units of pressure measured (e.g., feet, inches, gallons, etc.), or be dual scale.

## **PART 3 EXECUTION**

### 3.1 CONTRACTOR'S VERIFICATION

- A. CONTRACTOR shall field measure dimensions and check possible interferences for the pipe system and accessories.

## PROCESS PIPING

### 3.2 PREPARATION

- A. Pipe fittings and accessories shall be free of all foreign matter. Accumulations of dirt, rust, scale, etc., shall be removed prior to installation. Pipe ends shall be reamed and deburred to prevent loose particles from getting into the pipe line.

### 3.3 INSTALLATION

#### A. General:

1. Piping installation shall be coordinated, with respect to space available, with heating, ventilating, and electrical installation. In every instance where there is a conflict in the routing of the piping and the ducting, the routing of the ducting shall govern. Installed piping shall not interfere with the operation or accessibility of doors or windows; shall not encroach on aisles, passageways, and equipment; and shall not interfere with the servicing or maintenance of equipment.
2. Pipe shall be cut accurately to measurements established at the construction site and shall be worked into place without springing or forcing, properly clearing all openings and equipment. Cutting or weakening of structural members to facilitate piping installation is not permitted.
3. Pipes shall have burrs removed by reaming and shall be so installed as to permit free expansion and contraction without damage to joints or hangers.
4. Aboveground piping shall be run parallel with the lines of the building unless otherwise noted on the drawings. Unless otherwise shown on the drawings, horizontal piping shall pitch down in the direction of flow with a grade of not less than 1 inch in 40 feet.
5. Service pipe, valves, and fittings shall be located a sufficient distance from other work to permit the installation of the finished covering not less than ½" from such other work, and not less than ½" between the finished covering on the different services.
6. Valves shall be installed at the locations shown on the drawings and where specified. Valves shall be installed with their stems orientated horizontal or vertical and with sufficient clearance to allow for full stem travel and the repair of two-piece or three-piece valves in place.
7. Piping connections to equipment shall be aligned and supported in such manner that no load or thrust will be exerted upon the equipment by the piping at installation or in operating conditions.
8. Cutting of the pipe shall be done in a neat workmanlike manner with the least amount of waste and without damage to existing or new lines. A fine tooth saw, tubing, or pipe cutter, or similar tool shall be used to cut the pipe. Cuts must be square and ragged edges removed with a burring tool and/or file.
9. After cutting bell and spigot or socket pipe a stop mark shall be made with a pencil or crayon using dimensions as shown by the manufacturer's instructions or by using another pipe in the field as a guideline.

**PROCESS PIPING**

- 10. Cutting of concrete walls, floors or ceilings shall be avoided and requires written approval from ENGINEER. If approved, holes shall be core drilled and patched. Reinforcement steel shall not be cut or disturbed.
- 11. At the termination of pipe installation any open ends of pipelines shall be closed off by a suitable cover until installation operations are resumed.
- 12. Provide plugged wyes, tees, or crosses with threaded joints at all changes in direction to facilitate cleaning of chemical lines.

**B. Pipe Supports:**

- 1. CONTRACTOR is responsible for sizing and spacing of pipe hangers and supports. A shop drawing, indicating the type, size and spacing of hangers and supports shall be prepared in accordance with recommendations by hanger and support manufacturers and pipe manufacturers.
- 2. Piping shall not be supported directly off of pumps, valves, instruments, and other components.
- 3. Piping shall be rigidly supported from the building structure by means of adjustable ring-type, clevis, or band-type hangers. Where pipes run side by side, they shall be supported using rod and angle iron, or Unistrut trapeze hangers.
- 4. Maximum distance between supports and minimum diameter of hangers shall be as follows:

Pipe Size (inches)	Maximum Distance Between Supports (feet)	Minimum Diameter of Hanger Rod (inches)
3/8 thru 2	6	3/8
2-1/4 thru 3	6	1/2
4 thru 5	8	5/8
6"	10	3/4
8" thru 12	10	7/8
14 thru 30	10	1

- 5. Polyvinyl chloride pipe, fiber glass reinforced pipe, rubber hose, tubing, etc., shall be supported along the entire length by means of a steel channel or angle iron or approved tray anchored to the floor, wall, or ceiling with supports per above. Where shown, chemical feed lines are installed in containment piping.
- 6. Piping 8-inch and larger located close to the floor shall be supported in concrete saddles. Welding to structural steel members shall not be permitted without written approval of ENGINEER.
- 7. Valves shall be supported to keep undue strain off of piping and adjacent equipment.
- 8. Equipment requiring periodic maintenance shall be supported to allow easy removal with a minimum of temporary supporting.
- 9. Hanger rods shall be connected to beam clamps or concrete inserts. Clamps or inserts shall be Underwriter's Laboratories approved. "C" clamps will not be permitted.

## PROCESS PIPING

10. Expansion anchors may be used upon written approval by ENGINEER. Holes for expansion anchors shall be made by rotary drilling only, hammering devices will not be permitted. Explosive studs may be used provided they are driven under safe conditions.
11. Anchors, guides and sway braces shall be provided to allow for forces on the piping system. Sleeves shall be provided on pipe subject to movement. Sleeves shall be no less than four inches wide or have a width equal to 1/3 the diameter of the pipe, whichever is larger.
12. Vertical piping shall be supported at each floor or grating level with approved riser clamps except where prohibited by piping flexibility requirements.  
Lateral movement of exposed vertical piping at building walls shall be restrained by anchor devices attached to walls except where prohibited by piping flexibility requirements. Provide retaining straps when clamps are used.

### C. Joints:

1. Flanged Joints: Flanged joints shall be face matched. Raised face flanges shall not be mated to flat-faced cast-iron flanges on valves or equipment. The raised face must be machined flush. All flange bolt holes shall straddle the horizontal and vertical centerlines unless otherwise noted. Install insulating kits on flanges connecting dissimilar metals such as steel to copper in order to prevent electrolytic action. Bolting shall comply with ASME B31.3, Process Piping. Torque values and tightening sequence for bolts shall be in accordance with flange manufacturer's instructions.
2. Threaded Joints: Threaded pipe joints shall have American Standard Taper Pipe Threads complying with ASME B1.2. Care shall be taken that the inside of pipe is thoroughly clean and free of cutting oil and foreign matter before installation. Metal screwed pipe joints shall be made leak-tight by the use of Teflon tape, pipe thread lubricant, or Teflon tape and a pipe-lubricating compound. Thermoplastic threaded pipe joints shall be made leak tight per product manufacturer's recommendations. When joining thermoplastic threaded pipe to metal threaded piping attempts should be made to screw the plastic pipe into female metal pipe fittings in order to reduce the likelihood of plastic fitting failure.
3. Solder-Joints: Tubing shall be cut square, reamed, and burrs removed. Both the inside of fittings and the outside of tubing shall be well cleaned with sand cloth or wire brush before sweating. Care shall be taken to prevent annealing of fittings and hard drawn tubing when making connections. Solders containing lead or cored solders are not permitted. Joints shall conform to ASTM B828. Joints shall comply with ASME B31.3, Process Piping and the Copper Development Association.
  - a. Solder containing antimony shall not be used to join metals containing zinc (e.g., galvanized iron, galvanized steel, and brass).



## PROCESS PIPING

- b. Use sand cloth or a stainless steel wire brush to clean surfaces to be joined.
- c. Solder End Valve:
  - (1) Use a gate, globe, two-piece or three-piece ball valve for solder end valves.
  - (2) When joining a solder end valve, ensure valve is fully open. Apply heat to tube first.
  - (3) Transfer as much heat as possible through the tube to the valve. Avoid prolonged heating of the valve.
  - (4) Use a noncorrosive paste flux and solid wire solder suitable for the service temperatures and pressures expected.
- 4. Brazed Joints: New copper systems shall be installed with socket type fittings and with an argon or nitrogen purge applied. Flux shall not be used except where joining specialty items and fittings that are not available in copper. Brazing filler metals shall comply with AWS A5.8, Specification for Brazing Filler Metals. Copper-to-copper joints shall be brazed using a copperphosphorus or copper-phosphorous-silver brazing filler metal (BCuP) without flux. Copper-to-bronze or copper-to-brass joints shall be brazed using an appropriate flux with 45% silver (Bag-5 series) brazing filler metal. The following procedure shall be followed:
  - a. Tube ends shall be cut square using a sharp tubing cutter. The wheel shall be free from grease, oil, or dirt. The cut end of the tubing shall be deburred with a sharp, clean deburring tool, taking care to prevent chips from entering the tube or pipe.
  - b. The surfaces to be brazed shall be mechanically cleaned. Joints shall be recleaned if they become contaminated prior to brazing. Joints shall be brazed within 1 hour of being cleaned.
  - c. Where dissimilar metal joints, such as copper to bronze or brass, are being brazed, flux shall be applied sparingly to minimize contamination of the inside of the tube with flux. Where possible, short sections of copper tube shall be brazed to the non-copper components and the interior of the subassembly shall be cleaned of the flux prior to installation in the piping system. Flux-coated brazing rods may be used in lieu of the application of flux to the surfaces to be joined for tubes  $\frac{3}{4}$ " size and smaller.
  - d. While being brazed, joints shall be continuously purged with oil-free dry nitrogen or argon to prevent the formation of copper oxide on

## PROCESS PIPING

the inside surface of the joint. The flow of the purge gas shall be maintained until the joint is cool to the touch.

- e. Exception: A final connection to an existing system shall be permitted to be made without the use of a purge gas.
- f. During and after installation, openings in the piping system shall be kept capped or plugged to avoid unnecessary loss of purge gas and to prevent contamination. Do not begin brazing until piping is fully purged of air. For continuous runs of piping, brazing shall begin at the purge port area and continue through the system.

The purge connection shall not be changed. While brazing, a discharge opening shall be provided on the opposite side of the joint from where the purge gas is introduced. During brazing, the purge gas flow rate shall be maintained at a level that will not produce a positive pressure in the piping system. While welding, the minimum purge rate shall be 15 scfh for ¼" tubing or 25 scfh for all tubing ⅜" and larger. Purge shall continue after completion of braze until the joint is cool.

- g. After brazing, the outside of all joints shall be cleaned by washing with water and a stainless steel brush to remove any residue and permit clear visual inspection of the joint. Where flux has been permitted, hot water shall be used.

- 5. **Welded Joints:** Joints between sections of pipe and between pipe and fittings may be welded using either gas or electric welding equipment. Stainless steel welding shall conform to AWS B2.1-8-005. All pipe surfaces shall be thoroughly cleaned before welding. Each joint, except socket-weld joints, shall be beveled before being welded. CONTRACTOR shall provide a nonflammable mat or blanket to protect the structure and adequate fire protection equipment at all locations where welding is done. Elbows shall be long radius where space conditions allow. Wherever branch connections are made to piping systems on the main run, welding sockets or weld-o-lets may be used in lieu of reducing outlet tees for branch connections up to one-half the size of the main run. On connections larger than one-half the size of the main run, welding tees shall be used. Use of fittings formed from welded pipe sections will not be permitted.
- 6. **Solvent Cement Joints:** CPVC and all thermoplastic pipe solvent cement joints shall follow the manufacturer's installation instructions for assembly of joints with respect to pipe size and ambient conditions. Installations shall comply with ASTM F 402 "Standard Practice for Safe Handling of Solvent Cements, Primers, and Cleaners Used for Joining Thermoplastic Pipe and Fittings".
- 7. **Copper or Copper Alloy Pressure Seal Joints:** Copper and copper alloy press connections shall be made in accordance with the manufacturer's installation instructions. Tubing shall be fully inserted into the fitting and the

## PROCESS PIPING

tubing marked at the shoulder of the fitting. The fitting alignment shall be checked against the mark on the tubing to assure the tubing is fully engaged (inserted) into the fitting. Joints shall be pressed using the tool(s) approved by the manufacturer.

8. Grooved joints shall be installed in accordance with the manufacturer's latest published installation instructions. Grooved ends shall be clean and free from indentations, projections, and roll marks in the area from pipe end to groove. Gaskets shall be of an Elastomer grade suitable for the intended service, and shall be molded and produced by the coupling manufacturer. The grooved coupling manufacturer's factory trained representative shall provide on-site training for contractor's field personnel in the use of grooving tools and installation of grooved joint products.

The representative shall periodically visit the jobsite and review contractor is following best recommended practices in grooved product installation. (A distributor's representative is not considered qualified to conduct the training or jobsite visit(s).

9. Expansion Joints: Expansion joints shall be installed where indicated on the Plans and in accordance with the manufacturer's recommendations. Pipe systems shall be properly supported so expansion joints do not carry any loads. Piping on equipment adjacent to expansion joints shall be anchored to prevent excessive elongation of the pipe system when subject to pressure. Restrained expansion joints shall be used when adequate anchoring is not available. Misalignment of installation shall not exceed 1/8" to allow full movement of expansion joints when necessary. Do not cover expansion joints with insulation. Straight, concentric or eccentric tapered joints shall be used as indicated on the Plans.

### D. Electrical Conductivity:

1. When indicated on the Plans or specified, ductile iron piping joints shall be bonded to provide electrical conductivity across the joints of both bell and mechanical joint pipe and fittings.
2. Cable conductor shall be flexible to simplify assembly and to withstand ground and pipe movement after installation. Installation shall provide a positive lasting connection.
3. Where required, bonds shall be made between cast and/or ductile iron pipe and steel pipe to ensure electrical conductivity across the joints.

## 3.4 FIELD QUALITY CONTROL

### A. General:

1. Installed pipe systems shall be tested by hydrostatic or pneumatic means as specified in Section 40 1000, Process Equipment General Requirement, and herein.

## PROCESS PIPING

2. Hydrostatic testing shall be for any fluid type material to be handled with pneumatic testing for any gas or air pressurized lines.
3. Testing shall be made with the temperatures of surrounding air and test water or air are approximately constant within operating temperature ranges.
4. Pipe ends shall be valved or blanked off. Exterior surfaces of pipes, fittings, or valves shall show no cracks or other forms of leakage.

### B. Hydrostatic Testing:

1. Process piping shall be tested with water. Where practical, the OWNER may supply final effluent water for testing purposes, but the CONTRACTOR may need to provide temporary piping, pumps or other equipment to transfer the final effluent water to the point of testing. Otherwise, the CONTRACTOR is responsible for purchasing potable water. Cost to purchase water for testing shall be included in the bid.
2. Exposed piping shall be drop tight for a period of two hours under test pressure of 25 psi. Buried piping shall exhibit a pressure drop not exceeding 1% after a 2 hour period under a 25 psi test pressure.

END OF SECTION

**SECTION 40 30 00**  
**VALVES: BASIC REQUIREMENTS**

**PART 1   GENERAL**

1.1    SUMMARY

A.    Section includes:

1.    Valving, actuators, and valving appurtenances.

B.    Related Sections include but are not necessarily limited to:

1.    Division 0 - Bidding Requirements, Contract Forms, and Conditions of the Contract.
2.    Division 1 - General Requirements.
3.    Section 09 9123 – Interior Painting
4.    Section 40 1000 – Process Equipment General Requirements
5.    Section 40 1500 - Process Piping

1.2    QUALITY ASSURANCE

A.    Referenced Standards:

1.    American National Standards Institute (ANSI):
  - a.    B1.20.1, Pipe Threads, General Purpose.
  - b.    B16.1, Cast Iron Pipe Flanges and Flanged Fittings.
  - c.    B16.18, Cast Copper Alloy Solder Joint Pressure Fittings.
  - d.    B16.34, Valves-Flanged, Threaded and Welding End.
  
2.    American Water Works Association (AWWA):
  - a.    C111, Rubber-Gasket Joints for Ductile Iron and Gray Iron Pressure Pipe and Fittings.
  - b.    C207, Steel Pipe Flanges for Waterworks Service - Sizes 4 IN through 144 IN.
  - c.    C500, Gate Valves for Water and Sewerage Systems.
  - d.    C504, Rubber Seated Butterfly Valves 3 through 72 NPS, for Water Systems.
  - e.    C540, Power-Actuating Devices for Valves and Slide Gates
  - f.    C550, Protective Epoxy Interior Coatings for Valves and Hydrants.
  - g.    C606, Grooved and Shouldered Joints.
  - h.    D648, Standard Test Method for Deflection Temperature of Plastics Under Flexural Load.

## VALVES: BASIC REQUIREMENTS

3. Manufacturers Standardization Society of the Valve and Fittings Industry, Inc.(MSS).
4. National Electrical Manufacturers Association (NEMA):
  - a. MG 1, Motors and Generators.
  - b. ICS 6, Enclosures for Industrial Controls and Systems.

### 1.3 DEFINITIONS

- A. The following are definitions of abbreviations used in this section or one of the individual valve sections.
  1. CWP: Cold water working pressure.
  2. SWP: Steam working pressure.
  3. WOG: Water, oil, gas working pressure.
  4. WWP: Water working pressure.

### 1.4 SUBMITTALS

- A. Shop Drawings:
  1. See Section 01 3300.
  2. Product technical data including:
    - a. Acknowledgement that products submitted meet requirements of standards referenced.
    - b. Manufacturer's installation instructions.
    - c. Valve pressure and temperature rating.
    - d. Valve material of construction.
    - e. Special linings.
    - f. Valve dimensions and weight.
    - g. Valve flow coefficient.
    - h. Wiring and control diagrams for electric or cylinder actuators.
  3. Test reports.
- B. Operation and Maintenance Manuals:
  1. See Section 01 3300.

## **PART 2 PRODUCTS**

### 2.1 BUTTERFLY VALVES

1. Type 1 - Circular, Iron body:
2. Type: AWWA C504, Short Body

## VALVES: BASIC REQUIREMENTS

3. Construction:
  - 1) Shafts, retaining rings and internal hardware: stainless steel.
  - 2) Body: Cast iron.
  - 3) Seats (Mounted in valve body): New natural or synthetic reinforced rubber suitable for air, water or sewage service. Provide a stainless steel seating edge on all discs.
  - 4) Disc: Ductile Iron with 316 Stainless Steel edge.
  - 5) Packing: Nitrile – Butadiene V-type packing. No asbestos permitted.
4. Required Features:
  - 1) Shaft seals for non-buried valves shall have a stuffing box and pull down packing gland. Packing shall be replaceable without removing the valve operator.
5. End Connection: Flanged, conforming to ANSI B16.1, Class 125, unless otherwise specified.
6. Operator: Provide enclosed worm gear drive manual operators as indicated and as specified in this Section.
7. Class: As specified in the Valve Schedule, Class 150 if not specified.
8. Manufacturer: Provide butterfly valves of one of the following:
  - 1) Crispin.
  - 2) DeZurik.
  - 3) Or approved equal.
9. Quantity: 1, 30 inch diameter, Flanged x Flanged

### 2.2 VALVE ACTUATORS

#### A. Exposed Valve Manual Actuators:

1. Provide for all exposed valves not having electric or cylinder actuators.
2. Provide handwheels for gate valves.
  - a. Size handwheels for valves in accordance with AWWA C500.
3. Provide lever actuators for plug valves and ball valves 3 IN DIA and smaller.
  - a. Provide at least two levers for each type and size of valve furnished.
4. Gear actuators required for plug valves 4 IN DIA and larger.
5. Gear actuators to be totally enclosed, permanently lubricated and with sealed bearings.
6. Provide chain actuators for valves 6 FT or higher from finish floor to valve centerline.
  - a. Cadmium-plated chain looped to within 3 FT of finish floor.
  - b. Equip chain wheels with chain guides to permit rapid operation with reasonable side pull without "gagging" the wheel.
7. Provide shop drawing indicating the orientation of manual actuators.

#### B. Electric Actuators

1. To be provided as noted on the drawings. Contractor to provide the actuator, all field power wiring, and all control wiring.
2. Electric motor operator lift mechanism including electric motor, reduction gearing, stem nut, torque and limit switches, strip heaters, reversing

## VALVES: BASIC REQUIREMENTS

magnetic starter, pushbutton controls, indicator lights, shop wiring, gear case and handwheel or chain wheel for operation in manual mode in the event of power failure.

3. Provide the following control components:
  1. Remote/local selector switch with auxiliary contact for remote monitoring of switch position.
  2. Open and closed pushbuttons.
  3. Open (green) and closed (red) position indicating lights.
  4. Mount controls on the cover of the unit.
4. Unit to be complete in a NEMA 4X enclosure requiring only field wiring by the CONTRACTOR. Motor to be 240V, 3-phase, 60 HZ.
5. Operating speed 12 inches per minute minimum.
6. Final motor and gearbox sizing to be determined by actuator manufacturer.
7. Acceptable manufacturers: Rotork, AUMA. Actuator to be similar to other existing actuators located throughout the plant. A manufacturer's field representative shall be on-site during the initial installation of no less than two actuators, and then provide an on-site inspection of all actuators once in operation.

### 2.3 FABRICATION

#### A. End Connections:

1. Provide the type of end connections for valves as required in the Piping Schedules or as shown on the Drawings.
2. Comply with the following standards:
  - a. Threaded: ANSI B1.20.1.
  - b. Flanged: ANSI B16.1 Class 125 unless otherwise noted or AWWA C207.
  - c. Bell and spigot or mechanical (gland) type: AWWA C111.
  - d. Soldered: ANSI B16.18.
  - e. Grooved: Rigid joints per Table 5 of AWWA C606.

#### B. Nuts, Bolts, and Washers:

1. Wetted or internal to be bronze or stainless steel. Exposed to be zinc or cadmium plated.

#### C. On Insulated Piping: Provide valves with extended stems to permit proper insulation application without interference from handle.

#### D. Epoxy Interior Coating:

1. Provide epoxy interior coating for all ferrous surfaces in accordance with AWWA C550.



## VALVES: BASIC REQUIREMENTS

### **PART 3 EXECUTION**

#### 3.1 INSTALLATION

- A. Install products in accordance with manufacturer's instructions.
- B. Painting Requirements:
  - 1. Comply with Section 09 9123 for painting and protective coatings.
- C. Support exposed valves and piping adjacent to valves independently to eliminate pipe loads being transferred to valve and valve loads being transferred to the piping.
- D. For threaded valves, provide union on one side within 2 FT of valve to allow valve removal.
- E. Install valves accessible for operation, inspection, and maintenance.

#### 3.2 ADJUSTING

- A. Adjustment of valves, actuators and appurtenant equipment to comply with manufacturer's recommendations. Operate valve, open and close at system pressures.

END OF SECTION

**VALVES: BASIC REQUIREMENTS**

**THIS PAGE INTENTIONALLY LEFT BLANK**

**SECTION 40 92 10  
CAST IRON SLUICE GATES**

**PART 1 GENERAL**

**1.1 SCOPE OF WORK**

- A. The cast iron sluice gates shall be manufactured by Rodney Hunt, Coldwell-Wilcox, or approved equal. Gates shall be furnished with all necessary accessories and parts for a complete installation and shall be the latest standard product of a manufacturer regularly engaged in the production of equipment of this type. All gates shall be furnished by the same manufacturer.

**1.2 RELATED REQUIREMENTS**

- A. This section includes, but is not limited to, specifications set forth herein for the following related items:
1. Concrete work as per Division 03.
  2. Non-shrink grout as per Section 04.
  3. Division 05 – Metals
  4. Division 26 – Electrical

**1.3 SUBMITTALS**

- A. Submit shop drawings and product data, in accordance with Section 01 3300 showing materials of construction and details of installation for:
1. Complete description of all materials.
  2. Shop and installation Drawings showing all details of construction, dimensions, and anchor bolt locations.
  3. A complete bill of materials.
  4. The weight of each gate including the operator.
- B. In the event the product submitted does not conform with certain details of the Specifications, a complete identification and description of the non-conforming aspects called out in a section of the Shop Drawing notes titled "EXCEPTIONS" and also clearly referencing the related components in the bill of materials.

**1.1 Operation and Maintenance Data**

1. Operating and Maintenance instructions for each different type of gate shall be furnished to the ENGINEER as per the applicable specification section.

**1.4 REFERENCE STANDARDS**

- A. AWWA Standard C501-Cast Iron Sluice Gates; most recent edition in effect at the time of bid. All other applicable standards as referenced within C501 shall also apply.

## **CAST IRON SLUICE GATES**

### 1.5 QUALITY ASSURANCE

- A. The slide and weir gates specified under this Section shall be furnished by a Manufacturer which is fully experienced, reputable, and qualified for the manufacture of the required equipment. The Manufacturer shall have a minimum of 10 years of demonstrated successful applications of gate equipment equivalent in type to those to be supplied under this specification, and references will be supplied at the request of the Engineer in evidence of this record. Best practices and methods shall be used in the design, manufacture and installation of these gates. The Contractor and the Contractor's employees or subcontractors installing the gates shall likewise be able to show successful experience in such construction.
- B. A manufacturer's representative who has complete knowledge of proper operation and maintenance of the equipment provided under this Section shall be provided for up to one 8-hour day to instruct representatives of the Owner and Engineer on these procedures. This work may not be conducted in conjunction with the inspection of the gate(s) installation and/or any testing required under the Contract. The training must occur on a separate day, after the equipment has been determined to be ready for service following startup, check out and testing. The Contractor shall provide a minimum ten (10) working days prior notice of training schedule to personnel of the Owner and Engineer. Training shall take place prior to final acceptance by Owner.

### 1.6 WARRANTY

- A. Manufacturer shall provide a warranty in accordance with the Contract, but in no case shall the warranty be less than one (1) year in duration.

## **PART 2 PRODUCTS**

### 2.1 CAST IRON SLUICE GATES

- A. The gates shall have dimensions suitable to meet the functional and mounting requirements as indicated in the Schedule and Plans.
- B. Materials of Construction:
  - 1. Iron Castings: ASTM A 126, Class B for wall thimbles, frames, discs, yoke, guides, floorstands, gear housings and other items.
  - 2. Bronze Castings: For wedges, thrust nut, lift nut and couplings: ASTM B 584.
  - 3. Bronze: For seat facings in frame and disc, stem guide and stem guide liners. ASTM B 139.
  - 4. Silicon Bronze: For adjusting screws and other fasteners, ASTM B 98.
  - 5. Stainless Steel: For stems, stem couplings, and fasteners, ASTM A 276, Type 304.

## CAST IRON SLUICE GATES

6. Stainless Steel: For flush bottom retainer bar, ASTM A 276, Type 304.
7. Elastomeric Materials: For flush bottom seal and frame to wall seal, Neoprene, ASTM D 2000.

### C. Frames:

1. Frame shall be cast iron, one-piece construction of the flanged or flat type as required and with opening as shown and specified.
2. Frame shall have machined dovetailed grooves on the front face into which bronze seat facings shall be driven and then machined.
3. Back flange of the frame shall be machined to bolt directly to the machined face of a wall thimble or pipe flange of a wall fitting.
4. All surfaces forming joints or bearings shall be machined.
5. Frames shall have integrally cast pads machined with keyways to receive top and bottom wedge seats.
6. Frame drilling for attachment to existing wall shall be as shown, specified or otherwise required for proper connection.
7. Gaskets shall be furnished as required by manufacturer.
8. Flange drilling shall conform to ANSI B16.1. Class shall be as designated on the sluice gate schedule. If not designated, conform to Class 25. Bolt spacing on rectangular gates shall not exceed 12 inches on centers.

### D. Disc:

1. Disc shall be of cast iron, one-piece construction, rectangular with integrally cast vertical and horizontal ribs. A reinforcing rib along each side shall be provided to ensure rigidity between the side wedges.
2. Disc shall have machined dovetailed grooves on the seating face into which bronze seat facings shall be driven and then machined. The disc and frame bronze seat facings shall be accurately machined and shall be in contact with one another across their entire width. Wedge pads for side, top, and bottom wedges shall be cast integrally on the disc and then machined to receive the adjustable bronze wedges. Each disc shall have a tongue on each side extending its full length into a recess in the disc guides. These tongues shall be accurately machined on contact surfaces. The maximum allowable clearance between the disc and disc guide shall be 1/16-inch.
3. Cast a heavily reinforced nut pocket integrally on the vertical centerline and above the horizontal center to receive the thrust nut.

## CAST IRON SLUICE GATES

### E. Guides:

1. Guides shall be cast iron, one or two piece construction, or may be cast integrally with the frame, designed to withstand the total thrust caused by water pressure and wedging action. Two piece guides shall have flanged upper and lower sections which shall be machine bolted and dowelled for perfect alignment of the guide grooves.
2. Guides shall be machined on all contact surfaces. Guides shall be of such length as to retain and support at least one-half of the vertical height of the disc in the full open position.
3. Guides shall be integral or attached to the frame with silicon bronze studs and nuts, and shall be dowelled to prevent any relative motion between the guides and the frame. Attach wedges to guides at points where, in the closed position, they will make full contact with the wedging surfaces on the disc.

### F. Wedges:

1. Wedges shall be solid cast bronze, machined on all contact surfaces, keyed to the cast iron pads to maintain adjustment by preventing undesirable rotation or lateral motion. Attach wedges to the disc with silicon bronze studs and nuts. Provide silicon bronze adjusting screws with lock nuts.
2. Securely attach bronze wedge seats to machined pads on the guides.

### G. Seat Facings:

1. All seat facings shall be bronze of a composition which will resist dezincification and shall increase in wearing ability with cold working.
2. Retain facings in a dovetail groove.

### H. Flush-Bottom Closure:

1. Where flush bottom gates are shown or specified, gates shall have a resilient seal attached to the bottom of the disc with a retainer bar and fasteners. Seal shall seat on a machined bar and stop flush with the invert.

## 2.2 MANUAL OPERATOR

- A. The standard gate operator will be a horizontal handwheel type mounted on the pedestal or benchstand unless otherwise specified.
1. The bronze operating nut of the operator will be accurately machined to match the thread of the rising stem. Non-rising stem operating nuts shall be plain bore with keyway.

## CAST IRON SLUICE GATES

2. Non-rising stems shall only be used where overhead space to accommodate a rising stem is limited, or where mounting the operator in a floor box is required.
  3. The operating nut shall be supported by reasonable ball or roller thrust bearings top and bottom secured in an accurately machined cast aluminum or iron housing bolted to the bench or pedestal.
- B. Where torque, operation or space requirements dictate, bevel gear boxes with either a handcrank or handwheel shall be supplied in lieu of the standard operator. In addition:
1. Bevel gear boxes shall have stainless-steel input and/or output shafts, with accurately machined gears supported by ball or roller bearings secured in an accurately machined cast aluminum or iron housing bolted to the bench or pedestal.
  2. An AWWA nut (with a floor box if required) will be supplied where t-wrench or portable actuator operation is required and may be a standalone input or an integral part of a crank, handwheel, or gear box.
- C. Regardless of the type of manual operator used to meet the specification, the maximum effort on the handwheel, crank or AWWA nut is to be limited to less than a 40 lb. pull.
- D. The lift mechanism will be capable of withstanding an effort of up to 200 lbs. or more without damage to the operator, stem or gate frame.
- E. Manually operated gates are to be supplied with adjustable stop collars as required to set the gate opening range.
- F. A portable electric or hydraulic operator with either a height adjustable floor stand or direct to bench/pedestal mount shall be supplied if specified in this Section, the Gate Schedule or Plans.

### 2.3 ELECTRIC ACTUATOR

- A. If specified an electric actuator shall be supplied and installed in the same manor and location as the previous specified manual operator.
- B. The electric actuator shall meet or exceed AWWA standard C542 Electric Motor Actuators for Valves and Slide Gates. See Specification 40 3000 for actuator requirements.

### 2.4 STEMS

- A. Stem shall be of machined from stainless-steel rod with accurately machined Acme stub threads.
- B. Stem shall be designed for a safety factor of 2 based on a critical buckling compressive load calculated by the Euler Column formula where  $C=2$  and assuming a 50 lb torque on the AWWA nut.

## CAST IRON SLUICE GATES

- C. Rising stem gates
  - 1. For rising stem gates, a stem pocket shall be welded to the face of the stiffened side of the plate and to the uppermost stiffener.
  - 2. The stem shall fit within the slide plate stem pocket and be attached to the pocket by means of a stainless-steel bolt capable of withstanding the full force of the operator stem under full design head.
  
- D. Non-rising stem gates
  - 1. For non-rising stem gates, the lift nut shall be secured within a nut pocket welded to the face of the stiffened side of the plate and to the uppermost stiffener.
  - 2. The stem shall be secured with a key to the operator nut keyway to prevent rotation and vertical movement of the stem.
  - 3. Where space allows, an extension tube shall be used for operator nut attachment above the plate in order to keep the stem out of the direct flow when the gate is opened. Extension tubes shall be welded to the face of the stiffened side of the plate and to the uppermost stiffener. The gate manufacturer shall determine the length and placement of the extension tube in order to maximize operational reliability and ease-of-maintenance characteristics of the gate operator.
  
- E. Stem guides will be supplied to support the stem as required to meet the stem design criteria and shall be fabricated of the same alloy material as the gate and frame.
  - 1. Stem guides shall have bronze or UHMW bushings to reduce stem friction and wear as required by the installation.
  - 2. Guides will be mounted on the gate frame or installation wall as required to support and align the stem(s) properly.
  - 3. Wall-mounted stem guides shall be adjustable in multiple dimensions to allow for alignment with the operator and gate nut.
  
- F. Stem Cover:
  - 1. Furnish all stems with a clear butyrate plastic pipe stem cover. Furnish covers with a cast aluminum adapter for mounting covers to floor stands. Furnish stem covers with gasketing and breathers to eliminate water intrusion into operators and condensation within the covers.
  - 2. Engrave covers with legible markings showing as a minimum the gate position at 1/4 open, 1/2 open, 3/4 open and full open.
  
- G. Manual Operated Floor or Bench Stand:
  - 1. Manual operation shall be by crank operated floorstand as shown and specified.



## CAST IRON SLUICE GATES

2. Crank- operated type will have either a single or double gear reduction as required. Provide each type with a threaded cast manganese bronze lift nut to engage the operating stem.
3. Provide anti-friction bearings to properly support both opening and closing thrusts.
4. Stands shall operate the gates under the specified operating head with not greater than a 40-pound pull on the crank or handwheel.
5. Totally enclose all components in a cast iron weatherproof housing. Provide positive mechanical seals to exclude moisture and dirt and prevent leakage of lubricant out of the unit.
6. Provide lubricating fittings for all gears and bearings.
7. Stands shall include a cast iron pedestal designed to position the input shaft approximately 36 inches above the operating floor. Permanently attach or cast an arrow with the word "OPEN" on the floorstand indicating the direction of rotation to open the gate.
8. Removable cranks shall be cast iron with a revolving brass grip. Removable handwheel shall be fabricated steel designed for rough treatment and minimum weight.
9. Local Controls (none):

### 2.5 GATE SCHEDULE

The following gate shall be furnished and installed as shown on the Drawings.

#### a. Sluice Gate Schedule

##### 1. RG-01 – (48" x 72")

▪ Size	48" Wide x 72" High
▪ Unseating Head	70 feet
▪ Seating Head	25 feet
▪ Operator Type	Electric motor actuator
▪ Gate Type	Self-contained
▪ Mounting Type	Flush mounted onto concrete wall with neoprene gasket

## **PART 3 EXECUTION**

### 3.1 INSTALLATION

## CAST IRON SLUICE GATES

- A. Installation of gates and appurtenances shall be performed by Contractor in a workmen like manner by employees with experience in gate installation, adjustment, and start-up.
- B. The Contractor shall be responsible to handle, store and install the gates in strict accordance with Manufacturer's shop drawings and Installation, Operations and Maintenance manual(s).
- C. Frames and guides shall be installed plumb and true, with all corners at 90 degrees prior to grouting. Embedded gates shall be properly supported to maintain gate alignment and position during grouting within preformed block-outs. Surface mounted gates shall have all anchor bolts and nuts, including frame position adjustment nuts, properly secured after alignment and positioning prior to grouting.

### 3.2 INSPECTION

- A. Manufacturer's Representative shall inspect gate installations in the presence of the Contractor prior to start-up and acceptance of the gates. Particular attention shall be paid to gate position and alignment which is critical to proper operation and sealing, and to anchor condition and depth (where applicable) to make sure gate installation is in accordance with Manufacturer's Shop Drawing(s).
- B. Gates shall be fully opened/closed through two complete cycles to observe for any difficulty in operation or binding of the plate or stem. If water is available for testing, leakage should be observed in the fully closed position and compared to the 0.1 gpm per wetted foot of perimeter allowed by AWWA C501. Gates that do not operate or seal properly shall be inspected by the Contractor and adjustments made to correct any deficiencies.
- C. Gates that still do not meet the Specifications after any required adjustments shall be removed and replaced at no cost to the Owner.

END OF SECTION

## **APPENDIX A**

# **HAZARDOUS MATERIALS INVESTIGATIONS**

**THIS PAGE LEFT BLANK INTENTIONALLY**

LARKIN ENVIRONMENTAL SOLUTIONS, INC.  
P. O. BOX 1627  
ELIZABETHTOWN, KY 42702

September 15, 2013

Mr. Ron Stewart  
Evergreen Environmental  
P. O. Box 839  
Crestwood, KY 40014

RE: ASBESTOS SAMPLING  
NORTHER KENTUCKY WATER DISTRICT  
OHIO RIVER PUMPING STATION

Ron,

After an asbestos inspection on September 5, 2013, bulk sampling and subsequent laboratory analysis from McCall & Spero, Inc. revealed asbestos containing materials was found at the site. Of the 5 bulk samples taken, **3 (three)** were shown to contain asbestos. Both of the pipe insulation contains Chrysotile asbestos as well as the pipe fitting insulation. The window glazing revealed no asbestos found.

Please see the attached bulk sample asbestos analysis sheet for results.

If you have any questions, please contact me at 270 769-7700 or 723-1840.

Sincerely,

*David Larkin*

David Larkin  
Larkin Environmental  
KY Asbestos Inspector I13-03-0457

**SUMMARY OF PLM BULK ANALYSIS RESULTS**

Page 1

Project Name: Northern Kentucky Water District, Pumping Station Project  
 McCall & Spero Environmental Project No. MSE-P863LE.1

MSE # P863LE.1-	SAMPLE # DESCRIPTION	ASBESTOS TYPE & %	OTHER FIBROUS MATERIAL & %	% NON-FIBROUS MATERIAL	COLOR
001	616.01 Glazing	ND	Cellulose / 5%	95%	White
002	616.02 Glazing	ND	Cellulose / 5%	95%	White
003	616.03 Pipe Lagging	CH / 25%	Cellulose / 25%	50%	White
004	616.04 Pipe Lagging	CH / 25%	Cellulose / 25%	50%	White
005	616.05 Pipe Fitting	CH / 50%	Cellulose / 25%	25%	Gray

NOTES:

ND = None Detected      CH = Chrysotile      A = Amosite      AC = Actinolite  
 CR = Crocidolite      AN = Anthophyllite      TR = Tremolite

For samples consisting of separate components, each component is analyzed and reported separately.

Results apply only to items tested. Quantification is accurate to within ± 10%. Results from this report must not be reproduced, except in full, with the approval of McCall & Spero Environmental, Inc. This report must not be used to claim product endorsement by NVLAP or any agency of the U.S. Government.

\*\* EPA recommends that bulk materials found negative for asbestos or less than one percent asbestos by polarized light microscopy that fall into one of five dominantly nonfriable categories be reanalyzed by an additional method, such as transmission electron microscopy. (EPA Notice of Advisory, FR Vol. 59, No. 146 & Test Method EPA 600/ R-93/ 116).

Analyst: Ryan J. Cox, B.A.

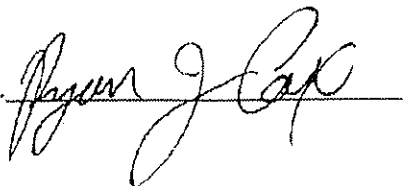

McCall & Spero Environmental, Inc.



Steven L. Beshear  
Governor



Leonard K. Peters  
Secretary

**Commonwealth of Kentucky**  
**Energy and Environment Cabinet**  
**Department for Environmental Protection**

Division for Air Quality  
200 Fair Oaks Lane, 1<sup>st</sup> Floor  
Frankfort, Kentucky 40601-1403  
www.air.ky.gov

March 8, 2013

Mr. David L. Larkin  
Larkin Environmental Solutions, Inc.  
P.O. Box 1627  
Elizabethtown, KY 42702

RE: I13-03-0457

Issued: 03-08-13  
Expires: 02-12-14

Dear Mr. Larkin:

This is to acknowledge receipt of your application for accreditation renewal as an asbestos abatement professional. Your application for *asbestos inspector* has been approved and the above-referenced card is enclosed.

Kentucky is issuing accreditation in five disciplines. It is important to note that accreditation in some disciplines automatically allows performance in other disciplines. A management planner is automatically allowed to perform additionally as an inspector, and an abatement supervisor is automatically allowed to perform additionally as an abatement worker. The initial accreditation fee is \$100.00 per person per discipline, except for abatement worker (\$20.00). For example, if anyone seeks accreditation as an inspector and an abatement worker, the fee will be \$120.00 and they will be issued two cards. If they seek accreditation in all five disciplines, the fee is \$300.00, and they will be issued three cards; one for project designer, management planner for inspections and plans, and supervisor for the other two disciplines. The renewal fee is one-half the initial fee. There is a \$10.00 duplication charge to replace a lost card.

If you have any questions regarding this matter you 05-call Ms. Cindy Mitchell at (502) 564-3999.

Sincerely,

Handwritten signature of Cindy K. Mitchell in cursive.

Cindy K. Mitchell  
Environmental Technologist III  
Field Support Section

COMMONWEALTH OF KENTUCKY  
DEPARTMENT FOR ENVIRONMENTAL PROTECTION  
DIVISION FOR AIR QUALITY  
CONFIRMS THAT

DAVID L. LARKIN

Has fulfilled the training requirements of 401 KAR 58.005 and is  
ACCREDITED as an

ASBESTOS INSPECTOR

Date Issued 03-08-13 Expires 02-12-14  
Handwritten signature of Cindy K. Mitchell  
Cindy Mitchell Environmental Technologist III  
No. I13-03-0457  
Handwritten signature of John S. Lyons  
John S. Lyons Director





November 12, 2013

Mr. Brent Tippey P.E.  
HDR, INC.  
Lexington, Kentucky

RE: LEAD SAMPLING  
NKWD  
PUMP STATION #2

Brent,

The inspection on September 5, 2013, lead sampling and lab analysis from Corrosion Control revealed traces of lead in the paint samples. The 10 samples were taken from all levels and rooms inside of the Pump Station. The samples ranged from 2.4 – 2,200 PPM. Many of the pipes and equipment found in the lower areas were 90% or more free of any protective coatings as result of corrosion.

All contractors should be aware of the lead percentage in order to be compliant OSHA Regulations. (Personal Protection)

Lead levels over 500 PPM are typically considered actionable levels for a full removal of the coating system and special lead disposal procedures.

The lab results indicate a percentage of lead content. The weight x 10,000 = PPM

Crain Rail:	2.9% - 290ppm
Structural steel Pump Rm:	3.2% - 320ppm
Elevator:	.42% - 42ppm
Wall Front Rm.:	.024% – 2.4ppm
Walls Pump Rm:	22% - 2,200ppm
Windows:	9.8% - 980ppm
Screen Water Pipe:	11% - 1100ppm
Stairway:	16% - 1600ppm
Water Pipe Pump Rm:	7.5% - 750ppm
Attic Structural Steel:	.70% - 70ppm

Sincerely,

Michael Topp  
Horizon QC Inc.  
502.727.2828

## ANALYTICAL LABORATORY REPORT

Monday, September 30, 2013

Page 4 of 4

**CUSTOMER:** Horizon Inspection Services  
P.O. Box 338  
Louisville, KY 40204

**DATE RECEIVED:** Thursday, September 19, 2013  
**PO/PROJECT #:**  
**SUBMITTAL #:** 2013-09-19-023

Unless otherwise noted, the condition of each sample was acceptable upon receipt, all laboratory quality control requirements were met, and sample results have not been adjusted based on field blank or other analytical blank results. Individual sample results relate only to the sample as received by the laboratory.

**Tests Reviewed By:** Jason Kraai, Senior Analyst *Jason Kraai* 2013.09.30 11:45:23  
CCC&L has obtained accreditation under the following programs:

- National Lead Laboratory Accreditation Program (NLLAP)**  
ELLAP: AIHA Laboratory ELLAP Accreditation Program Laboratory, ID#101030 ([www.aiha.org](http://www.aiha.org))  
OH: Ohio Department of Health Lead Poisoning Prevention Program, Approval #E10013 ([www.odh.ohio.gov](http://www.odh.ohio.gov))
- AIHA Laboratory IHLAP Accreditation Program** ([www.aiha.org](http://www.aiha.org))  
IHLAP: Laboratory ID#101030
- National Environmental Laboratory Accreditation Program (NELAP)**  
NY: State of New York Department of Health, Laboratory ID#11609 (Serial # 48735 through 48739) (518-485-5570)  
LA: State of Louisiana Department of Environmental Quality, Laboratory ID#180321 (Certificate 05036) ([www.deq.louisiana.gov](http://www.deq.louisiana.gov))  
OK: Oklahoma Department of Environmental Quality, Laboratory ID#9993 (Certificate 2013-040) ([www.deq.state.ok.us](http://www.deq.state.ok.us))

The accreditations pertain only to the testing performed for the elements, and in accordance with the test methods, listed in the table below. Testing which is performed by CCC&L according to other test methods, or for elements which are not included in the table below fall outside of the current scope of laboratory accreditation. Customers are encouraged to verify the current accreditation status with the individual accreditation programs by calling or visiting the appropriate website for the applicable program.

**SCOPE OF ACCREDITATION****Air and Emissions**

<u>Element/Test</u>	<u>Method</u>	<u>Accreditation(s)</u>
Particulates (PM10)	40 CFR 50 Appendix J	NY, LA
Total Suspended Particulates (TSP)	40 CFR 50 Appendix B	NY, LA
Lead in Airborne Dust	NIOSH 7300	ELLAP, OH, NY, LA
Lead in Airborne Dust	EPA 600/R-93/200/ EPA 6010C	ELLAP, OH
Metals in Airborne Dust	EPA 600/R-93/200/ NIOSH 7300/ EPA 6010C	IHLAP

**Solid Chemical Materials**

<u>Element/Test</u>	<u>Method</u>	<u>Accreditation(s)</u>
TCLP	EPA 1311 (Sample Preparation Method)	NY, LA, OK
Acid Digestion	EPA 3050B	NY, LA
Lead in Soil	EPA 3050B/ EPA 6010C	ELLAP, OH, NY, LA, OK
Lead in Paint	EPA 3050B/ EPA 6010C	ELLAP, OH, NY, LA
Lead in Paint	ASTM D 3335-85A/ EPA 6010C	NY
Lead in Dust Wipes	EPA 3050B/ EPA 6010C	NY, LA
Lead in Dust Wipes	EPA 600/R-93/200/ EPA 6010C	ELLAP, OH

**Non-Potable Water / Analysis by ICP**

<u>Element/Test</u>	<u>Method</u>	<u>Accreditation(s)</u>
Arsenic	EPA 6010C/ EPA 200.7 Rev 4.4	NY, LA, OK
Barium	EPA 6010C/ EPA 200.7 Rev 4.4	NY, LA, OK
Cadmium	EPA 6010C/ EPA 200.7 Rev 4.4	NY, LA, OK
Chromium	EPA 6010C/ EPA 200.7 Rev 4.4	NY, LA, OK
Copper	EPA 6010C/ EPA 200.7 Rev 4.4	NY, LA, OK
Lead	EPA 6010C/ EPA 200.7 Rev 4.4	NY, LA, OK
Mercury	EPA 245.1 Rev.3	NY, LA, OK
Mercury	EPA 7470A	NY, LA, OK
Nickel	EPA 6010C/ EPA 200.7 Rev 4.4	NY, LA, OK
Selenium	EPA 6010C/ EPA 200.7 Rev 4.4	NY, LA, OK
Silver	EPA 6010C/ EPA 200.7 Rev 4.4	NY, LA, OK
Zinc	EPA 6010C/ EPA 200.7 Rev 4.4	NY, LA, OK
Acid Digestion	EPA 3010A	NY, LA

This report shall not be reproduced except in full, without written approval of CCC&L.

## ANALYTICAL LABORATORY REPORT

Monday, September 30, 2013

Page 1 of 4

**CUSTOMER:** Horizon Inspection Services  
P.O. Box 338  
Louisville, KY 40204

**DATE RECEIVED:** Thursday, September 19, 2013  
**PO/PROJECT #:**  
**SUBMITTAL #:** 2013-09-19-023

**LAB NUMBER: AB63382**

**Sampled By:** Michael Topp  
**Job Location:** NKWD Pump Station 2  
**Sample Identification:** 1 - Crane Rail

**Date Sampled:** Saturday, September 7, 2013  
**Sample Description:** Paint Chips

**Preparation Method:** EPA 3050B-P-M (Acid Digestion for Paints)  
**Analysis Method:** EPA 6010C (ICP-AES Method for Determination of Metals)  
**Date Analyzed:** Friday, September 20, 2013

ELEMENT	RESULT (by dry weight)	REPORTING LIMIT (RL)
Lead	2.9 %	0.0025 %

**LAB NUMBER: AB63383**

**Sampled By:** Michael Topp  
**Job Location:** NKWD Pump Station 2  
**Sample Identification:** 2 - Structural Steel Pump RM

**Date Sampled:** Saturday, September 7, 2013  
**Sample Description:** Paint Chips

**Preparation Method:** EPA 3050B-P-M (Acid Digestion for Paints)  
**Analysis Method:** EPA 6010C (ICP-AES Method for Determination of Metals)  
**Date Analyzed:** Friday, September 20, 2013

ELEMENT	RESULT (by dry weight)	REPORTING LIMIT (RL)
Lead	3.2 %	0.0025 %

**LAB NUMBER: AB63384**

**Sampled By:** Michael Topp  
**Job Location:** NKWD Pump Station 2  
**Sample Identification:** 3 - Elevator

**Date Sampled:** Saturday, September 7, 2013  
**Sample Description:** Paint Chips

**Preparation Method:** EPA 3050B-P-M (Acid Digestion for Paints)  
**Analysis Method:** EPA 6010C (ICP-AES Method for Determination of Metals)  
**Date Analyzed:** Friday, September 20, 2013

ELEMENT	RESULT (by dry weight)	REPORTING LIMIT (RL)
Lead	0.42 %	0.0025 %

**LAB NUMBER: AB63385**

**Sampled By:** Michael Topp  
**Job Location:** NKWD Pump Station 2  
**Sample Identification:** 4 - Walls- Front Rm

**Date Sampled:** Saturday, September 7, 2013  
**Sample Description:** Paint Chips

**Preparation Method:** EPA 3050B-P-M (Acid Digestion for Paints)  
**Analysis Method:** EPA 6010C (ICP-AES Method for Determination of Metals)  
**Date Analyzed:** Friday, September 20, 2013

ELEMENT	RESULT (by dry weight)	REPORTING LIMIT (RL)
Lead	0.024 %	0.0025 %

CCC&L has obtained accreditation under the programs detailed on the final page of the laboratory report. The accreditations pertain only to the testing performed for the elements, and in accordance with the test methods, listed in the scope of accreditation table. Testing which is performed by CCC&L according to other test methods, or for elements which are not included in the table fall outside of the current scope of laboratory accreditation.

This report shall not be reproduced except in full, without written approval of CCC&L.

## ANALYTICAL LABORATORY REPORT

Monday, September 30, 2013

Page 2 of 4

**CUSTOMER:** Horizon Inspection Services  
P.O. Box 338  
Louisville, KY 40204

**DATE RECEIVED:** Thursday, September 19, 2013  
**PO/PROJECT #:**  
**SUBMITTAL #:** 2013-09-19-023

**LAB NUMBER: AB63386**

**Sampled By:** Michael Topp  
**Job Location:** NKWD Pump Station 2  
**Sample Identification:** 5 - Walls- Pump Rm

**Date Sampled:** Saturday, September 7, 2013  
**Sample Description:** Paint Chips

**Preparation Method:** EPA 3050B-P-M (Acid Digestion for Paints)  
**Analysis Method:** EPA 6010C (ICP-AES Method for Determination of Metals)  
**Date Analyzed:** Monday, September 23, 2013

<u>ELEMENT</u>	<u>RESULT (by dry weight)</u>	<u>REPORTING LIMIT (RL)</u>
Lead	22 %	0.0025 %

**LAB NUMBER: AB63387**

**Sampled By:** Michael Topp  
**Job Location:** NKWD Pump Station 2  
**Sample Identification:** 6 - Windows

**Date Sampled:** Saturday, September 7, 2013  
**Sample Description:** Paint Chips

**Preparation Method:** EPA 3050B-P-M (Acid Digestion for Paints)  
**Analysis Method:** EPA 6010C (ICP-AES Method for Determination of Metals)  
**Date Analyzed:** Wednesday, September 25, 2013

<u>ELEMENT</u>	<u>RESULT (by dry weight)</u>	<u>REPORTING LIMIT (RL)</u>
Lead	9.8 %	0.0025 %

**LAB NUMBER: AB63388**

**Sampled By:** Michael Topp  
**Job Location:** NKWD Pump Station 2  
**Sample Identification:** 7 - Screen Water Pipe- Silver lower area

**Date Sampled:** Saturday, September 7, 2013  
**Sample Description:** Paint Chips

**Preparation Method:** EPA 3050B-P-M (Acid Digestion for Paints)  
**Analysis Method:** EPA 6010C (ICP-AES Method for Determination of Metals)  
**Date Analyzed:** Wednesday, September 25, 2013

<u>ELEMENT</u>	<u>RESULT (by dry weight)</u>	<u>REPORTING LIMIT (RL)</u>
Lead	11 %	0.0047 %

**LAB NUMBER: AB63389**

**Sampled By:** Michael Topp  
**Job Location:** NKWD Pump Station 2  
**Sample Identification:** 8 - Stairway

**Date Sampled:** Saturday, September 7, 2013  
**Sample Description:** Paint Chips

**Preparation Method:** EPA 3050B-P-M (Acid Digestion for Paints)  
**Analysis Method:** EPA 6010C (ICP-AES Method for Determination of Metals)  
**Date Analyzed:** Wednesday, September 25, 2013

<u>ELEMENT</u>	<u>RESULT (by dry weight)</u>	<u>REPORTING LIMIT (RL)</u>
Lead	16 %	0.0025 %

CCC&L has obtained accreditation under the programs detailed on the final page of the laboratory report. The accreditations pertain only to the testing performed for the elements, and in accordance with the test methods, listed in the scope of accreditation table. Testing which is performed by CCC&L according to other test methods, or for elements which are not included in the table fall outside of the current scope of laboratory accreditation.

This report shall not be reproduced except in full, without written approval of CCC&L.

## ANALYTICAL LABORATORY REPORT

Monday, September 30, 2013

Page 3 of 4

**CUSTOMER:** Horizon Inspection Services  
P.O. Box 338  
Louisville, KY 40204

**DATE RECEIVED:** Thursday, September 19, 2013  
**PO/PROJECT #:**  
**SUBMITTAL #:** 2013-09-19-023

**LAB NUMBER: AB63390**

**Sampled By:** Michael Topp  
**Job Location:** NKWD Pump Station 2  
**Sample Identification:** 9 - Water pipe - Pump Rm

**Date Sampled:** Saturday, September 7, 2013  
**Sample Description:** Paint Chips

**Preparation Method:** EPA 3050B-P-M (Acid Digestion for Paints)  
**Analysis Method:** EPA 6010C (ICP-AES Method for Determination of Metals)  
**Date Analyzed:** Wednesday, September 25, 2013

<u>ELEMENT</u>	<u>RESULT (by dry weight)</u>	<u>REPORTING LIMIT (RL)</u>
Lead	7.5 %	0.0025 %

**LAB NUMBER: AB63391**

**Sampled By:** Michael Topp  
**Job Location:** NKWD Pump Station 2  
**Sample Identification:** 10 - Attic Structural Steel

**Date Sampled:** Saturday, September 7, 2013  
**Sample Description:** Paint Chips

**Preparation Method:** EPA 3050B-P-M (Acid Digestion for Paints)  
**Analysis Method:** EPA 6010C (ICP-AES Method for Determination of Metals)  
**Date Analyzed:** Wednesday, September 25, 2013

<u>ELEMENT</u>	<u>RESULT (by dry weight)</u>	<u>REPORTING LIMIT (RL)</u>
Lead	0.70 %	0.0025 %

CCC&L has obtained accreditation under the programs detailed on the final page of the laboratory report. The accreditations pertain only to the testing performed for the elements, and in accordance with the test methods, listed in the scope of accreditation table. Testing which is performed by CCC&L according to other test methods, or for elements which are not included in the table fall outside of the current scope of laboratory accreditation.

This report shall not be reproduced except in full, without written approval of CCC&L.

## **APPENDIX B**

### **TERRACON DIVE INSPECTION REPORT**

**THIS PAGE LEFT BLANK INTENTIONALLY**

# Underwater Assessment Ohio River Pumping 2

Ohio River Pump Station 2 (Old Newport Pump Station)

Ft. Thomas, Kentucky

April 11, 2016

Terracon Project Number: N1151161- Task 4



**Prepared for:**

Northern Kentucky Water District  
Fort Thomas, Kentucky

**Prepared by:**

Terracon Consultants, Inc.  
Cincinnati, Ohio

[terracon.com](http://terracon.com)

**Terracon**

Environmental



Facilities



Geotechnical



Materials





April 11, 2016

Northern Kentucky Water District  
700 Alexandria Pike  
Ft. Thomas, Kentucky 41075

Attn: Mr. Dave Enzweiler  
Pumping Supervisor  
P: 859-547-3265  
F: 859-572-4797  
E: denzweil@nkywater.org

Re: Report of Underwater Assessment  
Special Assessment  
Ft. Thomas, Kentucky  
Terracon Project Number: N1151161 –Task 4

Dear Mr. Enzweiler

In accordance with your request, Terracon Consultants, Inc. (Terracon) is pleased to provide you with the results of the Special Underwater Assessment Program. This report provides a summary of our findings for the information requested at the Ohio River Pumping Station 2 (Old Newport Intake) Structure assessed March 31, 2016.

We appreciate the opportunity to provide these observation services and look forward to continuing to provide our professional services for your project. If you have any questions concerning this report, or if we may be of further service, please contact Brad Walden at 513-623-1816, or [brad.walden@terracon.com](mailto:brad.walden@terracon.com).

Sincerely,  
**Terracon Consultants, Inc.**

Brad Walden  
Diving Services Manager

Jason Sander, P.E.  
Office Manager



Terracon Consultants Inc. 611 Lunken Park Drive Cincinnati, Ohio 45226  
P [513] 321 5816 F [513] 321 0294 [www.terracon.com](http://www.terracon.com)

Environmental



Facilities



Geotechnical



Materials

## 1.0 INTRODUCTION

Terracon is pleased to deliver you with the results of our special underwater assessments conducted on March 31, 2016. This assessment provides the design firm WadeTrim with relevant information pertaining to rehabilitation of the Ohio River Pumping Station 2.

## 2.0 INSPECTION PROCEDURE

The assessment was conducted utilizing an OSHA approved three man dive team utilizing surface supplied air diving techniques. The diver/engineering technician performed a visual/tactile inspection of the underwater elements. The visual/tactile assessment was enhanced with a closed-circuit underwater video camera and light as well as voice communication. Measurements were taken with a standard Lufkin 3/4" x 12' retractable tape measure. A pneumofathometer (depth gauge) was utilized to provide depths below the water; this system is accurate to +/- 6 inches.

## 3.0 ASSESSMENT RESULTS

The following provides a description of the conditions observed during the assessment. The description is accompanied with a sketch depicting the observed conditions. The sketch of the structural element allows better visualization at the time of the assessment.

Prior to the assessment, the design team of WadeTrim submitted specific questions to the district. These questions were related to features of the primary intake conduit and sluice gate. The questions are listed below and the assessment findings are underlined.

### General

- Is there much sediment accumulation within the inlet channel and inlet conduit?

Yes.

- Approximate depth of accumulation within channel?

There is approximately 30 inches of sediment and debris in the conduit. The sediment and debris along the wet well floor adjacent to the conduit opening is at the same level as the sediment and debris in the conduit.

- What is the condition of the concrete within the inlet channel above the sluice gate opening?

The concrete observed was found to be in fair condition. When sounded with a hammer, no unsound concrete was detected.

### Intake conduit:

- Dimensions - height, width and depth/ length?

The inside dimension of the conduit is approximately thirty-six inches wide and fifty-eight inches high. Due to the sediment within the invert of the conduit, the measurement was difficult to obtain

## Special Underwater Assessment

Ohio River Pump Station 2 ■ Ft. Thomas, KY

April 11, 2016 ■ Terracon Project No. N1151161 – Task 4



and may be slightly larger. The original conduit is approximately six feet in length, however the conduit has been extended approximately six additional feet to incorporate the repairs to the upstream corner.

- Approximate distance from end of conduit to trash rack?

Eighteen inches. The trash rack appears to be old railroad rails cast into the concrete conduit extension in a vertical position.

- Thickness of the conduit walls?

This information could not be determined.

- Condition of the interior concrete conduit walls?

The concrete observed was found to be in fair condition. When sounded with a hammer, no unsound concrete was detected. However, when the crown or ceiling of the conduit was sounded with a hammer, the resonances were different than that of the conduit walls indicating possible delamination.

### **Inlet sluice gate:**

- Wall thimble interior dimensions (height, width and depth/length)?

The engineering technician/diver was unable to differentiate where the thimble/concrete started and stopped.

- Wall thimble exterior dimensions (height and width)?

The width is approximately forty-five inches. When the gate guide rails are included, the width is approximately fifty-five inches. The height is approximately sixty-nine inches. The thimble frame is approximately one inch thick. The thimble frame was found to be covered in rust nodules and rated as moderately corroded. When the rust nodules were removed, the underlining steel frame was found to be etched and pitted up to one-eighth of an inch.

- Is there a gap between the wall and the thimble, if so, what is the dimension of the gap?

Seven inches. In addition the gap appeared to have been grouted at some point but the grout is distressed and is breaking away.

- Does the concrete surrounding the thimble appear sound?

The concrete appears to be in fair condition.

The assessment was performed by:

Dive Supervisor – Brad Walden

Engineering technician/diver – Zach Harrison

Standby Diver/Tender – Jason Hickey, PE



**Special Underwater Assessment**

Ohio River Pump Station 2 ■ Ft. Thomas, KY

April 11, 2016 ■ Terracon Project No. N1151161 – Task 4



**DRAWINGS**

PROJECT: NKWD, GRP 2, Sluice/Conduit Assessment Page 1 of 2

JOB NO. N1151161 <sup>TASK</sup> 4 Date 3/31/16 Comp. By BTW CHECKED BY: \_\_\_\_\_

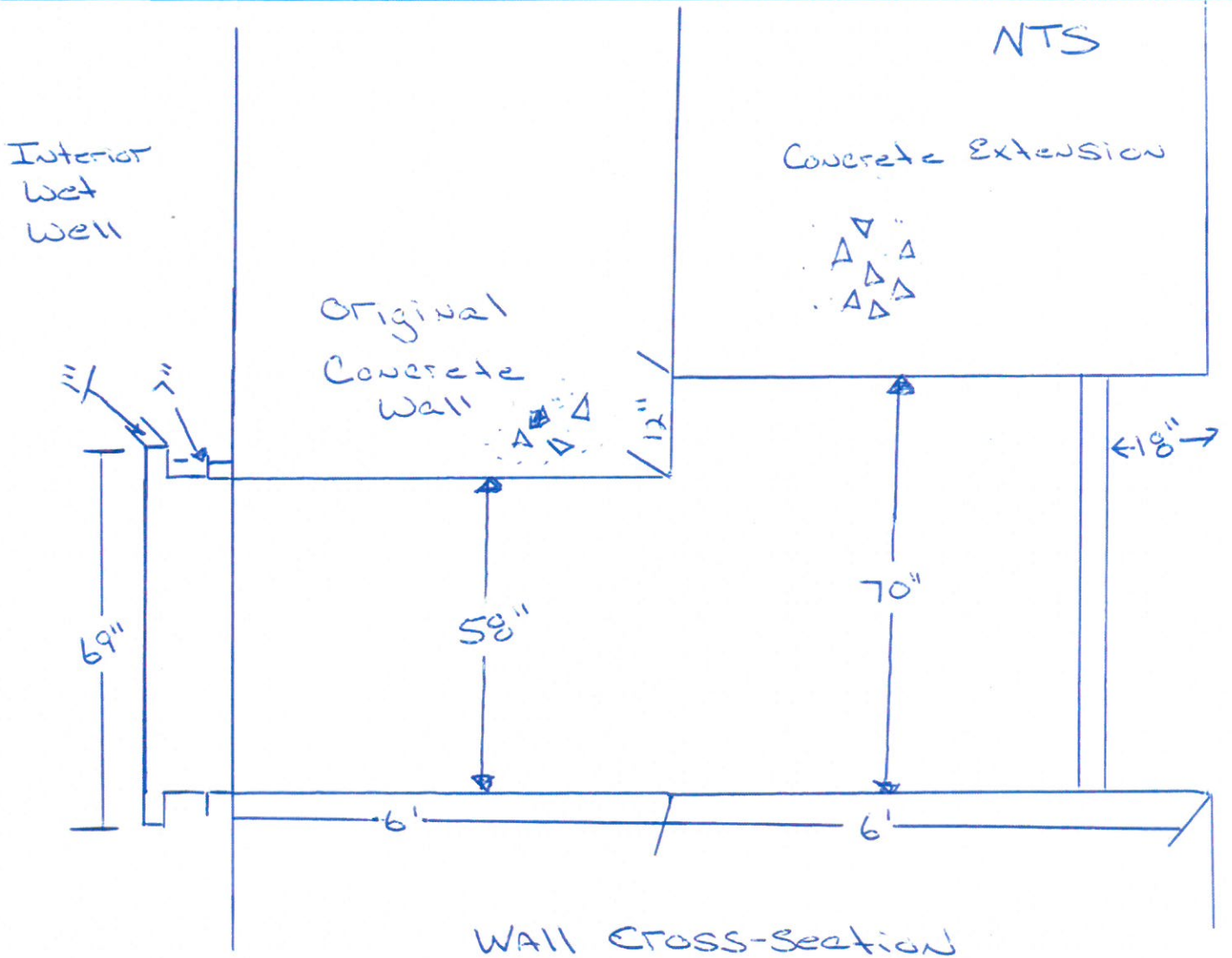

WALL CROSS-SECTION

PROJECT: NKWD ORP 2, Sloice/Conduit Assessment Page 2 of 2

JOB NO. N151161 <sup>TASK</sup> 4 Date 31 MARCH 16 Comp. By BTW CHECKED BY: \_\_\_\_\_

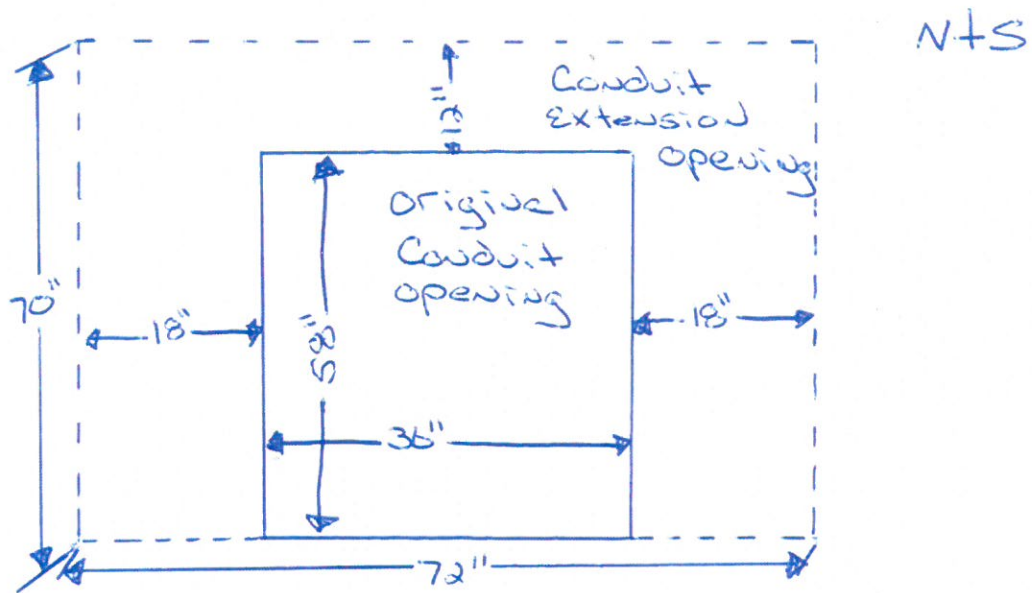

Elevation View of Conduit  
looking From the River Inward

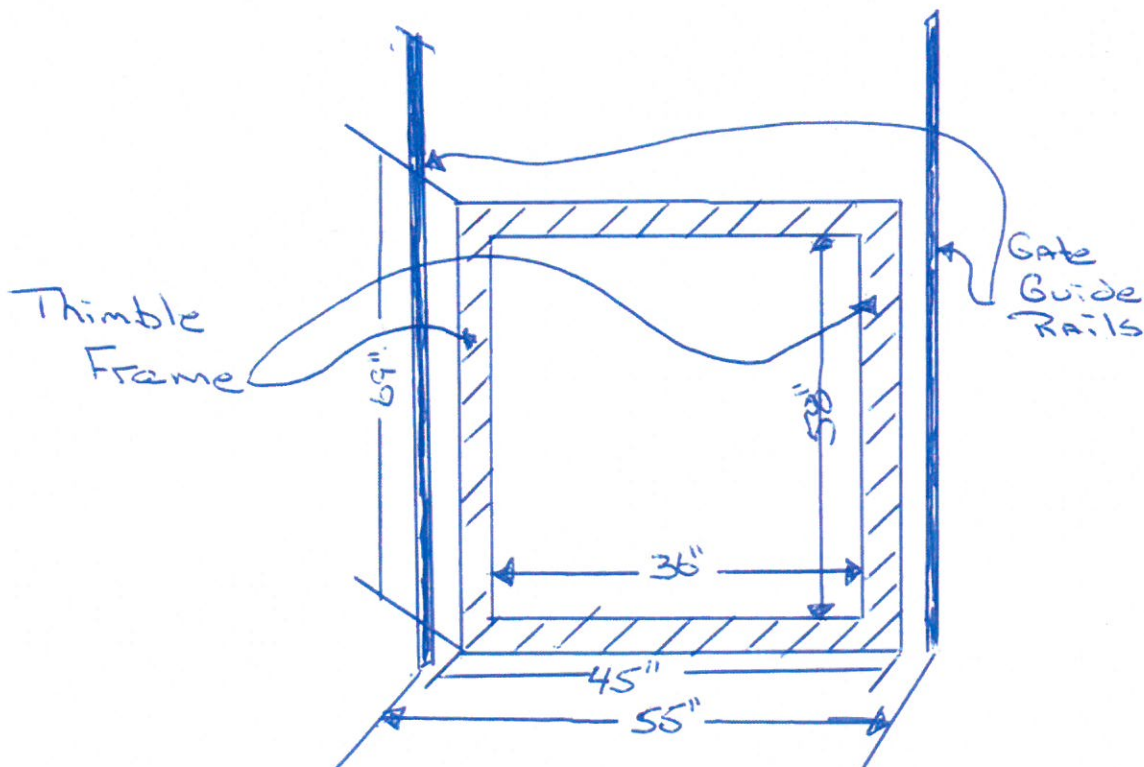

# **APPENDIX C**

## **PERMITS**

**THIS PAGE LEFT BLANK INTENTIONALLY**